











# Journal of Hymenoptera Research

Volume 10, Number 1

April 2001

ISSN #1070-9428

## CONTENTS

- BAYLISS, P. S. and D. J. BROTHERS. Behaviour and host relationships of *Dolichomutilla scyorax* (Smith) (Hymenoptera: Mutillidae, Sphecidae) ..... 1
- CARVALHO, G. A. The number of sex alleles (CSD) in a bee population and its practical importance (Hymenoptera: Apidae) ..... 10
- GESS, S. K. Distribution and ethology of *Priscomasaris* Gess (Hymenoptera: Vespidae: Masarinae: Priscomasarina) in Namibia ..... 16
- GIBSON, G. A. P. The Australian species of *Pachyneuron* Walker (Hymenoptera: Chalcidoidea: Pteromalidae) ..... 29
- JANJIC, J. and L. PACKER. New descriptions of *Halictus* (*Seladonia*) from the New World (Hymenoptera: Halictidae) ..... 55
- KIMSEY, L. The new Western Australian tiphiiid genus *Dythynnus* (Hymenoptera: Tiphidae: Thynninae) ..... 76
- MASON, P. G., M. A. ERLANDSON, and B. J. YOUNGS. Effects of parasitism by *Banchus flavescens* (Hymenoptera: Ichneumonidae) and *Microplitis mediator* (Hymenoptera: Braconidae) on the bertha armyworm, *Mamestra configurata* (Lepidoptera: Noctuidae) ..... 81
- MASSA, B., M. C. RIZZO, and V. CALECA. Natural alternative hosts of Eulophidae (Hymenoptera: Chalcidoidea) parasitoids of the citrus leafminer *Phyllocnistis citrella* Stainton (Lepidoptera: Gracillariidae) in the Mediterranean basin ..... 91
- SHAW, M. R. Interactions between adults of some species of *Netelia* Gray (Hymenoptera: Ichneumonidae: Tryphoninae) and their caterpillar hosts (Lepidoptera) ..... 101



# INTERNATIONAL SOCIETY OF HYMENOPTERISTS

Organized 1982; Incorporated 1991

---

## OFFICERS FOR 2001

John LaSalle, *President*  
Lynn Kimsey, *President-Elect*  
James B. Woolley, *Secretary*  
John T. Huber, *Treasurer*  
E. Eric Grissell, *Editor*

---

## Subject Editors

SYMPHYTA AND PARASITICA

*Biology:* Mark Shaw

*Systematics:* Donald Quicke

ACULEATA

*Biology:* Sydney Cameron

*Systematics:* Wojciech Pulawski

---

All correspondence concerning Society business should be mailed to the appropriate officer at the following addresses: President, CSIRO Entomology, GPO Box 1700, Canberra, ACT 2601, Australia; Secretary, Department of Entomology, Texas A&M University, College Station, Texas 77843; Treasurer, Eastern Cereal & Oilseed Research Centre, Agriculture Canada, K. W. Neatby Building, Ottawa, Ontario, Canada K1A 0C6; Editor, Systematic Entomology Laboratory, USDA, c/o National Museum of Natural History, Washington, D.C. 20560-0168.

**Membership.** Members shall be persons who have demonstrated interest in the science of entomology. Annual dues for members are US\$40.00 per year (US\$35.00 if paid before 1 February), payable to The International Society of Hymenopterists. Requests for membership should be sent to the Treasurer (address above). Information on membership and other details of the Society may be found on the World Wide Web at <http://IRIS.biosci.ohio-state.edu/ish>.

**Journal.** The *Journal of Hymenoptera Research* is published twice a year by the International Society of Hymenopterists, c/o Department of Entomology, Smithsonian Institution, Washington, D.C. 20560-0168, U.S.A. Members in good standing receive the *Journal*. Nonmember subscriptions are \$60.00 (U.S. currency) per year.

The Society does not exchange its publications for those of other societies.

**Please see inside back cover of this issue for information regarding preparation of manuscripts.**

---

## Statement of Ownership

Title of Publication: Journal of Hymenoptera Research.

Frequency of Issue: Twice a year.

Location of Office of Publication, Business Office of Publisher and Owner: International Society of Hymenopterists, c/o Department of Entomology, Smithsonian Institution, 10th and Constitution NW, Washington, D.C. 20560-0168, U.S.A.

Editor: E. Eric Grissell, Systematic Entomology Laboratory, USDA, c/o National Museum of Natural History, Washington, D.C. 20560-0168.

Managing Editor and Known Bondholders or other Security Holders: none.

---

This issue was mailed 26 April 2001

## Behaviour and Host Relationships of *Dolichomutilla sycorax* (Smith) (Hymenoptera: Mutillidae, Sphecidae)

PAUL S. BAYLISS AND DENIS J. BROTHERS

School of Botany & Zoology, University of Natal (Pietermaritzburg), Private Bag X01,  
Scottsville, 3209 South Africa; (PSB: Current address: Transvaal Museum, P.O. Box 413,  
Pretoria, 0001 South Africa)

---

*Abstract.*—Detailed biological information for species of Mutillidae is generally lacking. The following aspects of the biology of *Dolichomutilla sycorax* (Smith), based on laboratory observations of 10 specimens (9♀, 1♂) reared from a single nest of *Sceliphron spirifex* (Linnaeus) (Sphecidae), are described in detail and discussed: emergence from host nest, activity patterns, mating and grooming. The recorded host relations for *D. sycorax* are also discussed.

---

Successful mating by mutillid wasps generally requires only a short time (Brothers 1972), and very few observations have been recorded. These are important in providing information on sex associations. Grooming in mutillids has recently been described for the first time (Bayliss and Brothers 1996), and only in the last few years has it been used in systematic studies of the Hymenoptera (Basibuyuk and Quicke 1999). This paper provides the first descriptions of mating and grooming behaviour in *Dolichomutilla sycorax* (Smith) and surveys the data on its host relationships, as well as providing some other incidental information on the behaviour of this species.

*Dolichomutilla sycorax* is broadly distributed throughout eastern Africa, from Kenya to South Africa where it is the most common species of the genus. Its taxonomic status as a valid species distinct from *Dolichomutilla guineensis* (Fabricius) has recently been clarified by Nonveiller (1996). Specimens are approximately 9–22 mm long, with the head and metasoma black and the mesosoma deep marooned. The apterous females have a pair of white spots on the second metasomal tergum and an interrupted broad white band

on the third tergum; the macropterous males are almost identical in coloration, unlike for most Mutillidae, and have conspicuously banded wings (Figs. 1–2). Although Gerstaecker (1857, 1862) first described the male (misidentified as that of *D. guineensis*), presumably based on the similarity of the sexes, Péringuey (1898) was the first to associate the sexes directly, having reared both simultaneously from the mud nests of *Pelopaues* [= *Sceliphron*] *spirifex* (Linnaeus) (Hymenoptera, Sphecidae).

### MATERIALS AND METHODS

Laboratory observations were made during April to December 1996 at the University of Natal, Pietermaritzburg. Live adults of *D. sycorax* were reared from a mud nest of *S. spirifex* collected at the Greater St Lucia Wetland Park, Ozabeni Section, Lower Mkuze, KwaZulu-Natal, South Africa (27°39'S, 32°26'E) on 6–9 April 1996 by R.M. Miller and J. Kotze. They emerged over a period of about 10 days (starting on 19 May 1996) and were kept isolated in petri dishes (diameter 90 mm, height 20 mm) after emergence. The bases of the dishes were lined with paper towelling to provide a rough substrate.

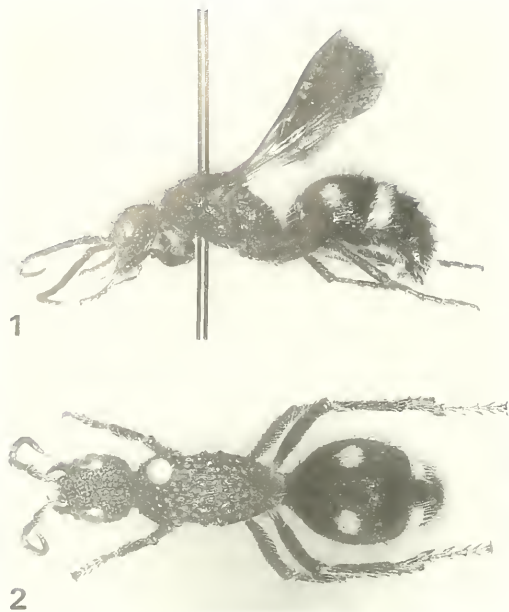

Figs. 1–2. *Dolichomutilla sycorax*. 1, ♂, lateral view (body length 10 mm). 2, ♀, dorsal view (body length 16 mm).

Mating was observed by placing two adults of opposite sex in the same petri dish; their behaviour was recorded using a Sony 8mm video camera and low-intensity cool fibre-optic illumination. The specimens were observed for at least 20 minutes, and if no interaction (including stridulation or rubbing of antennae) occurred between them during that time, they were separated for several hours before placing them together again.

A Wild M5 stereo microscope, using white light from a desk lamp, was used for observations of grooming at irregular intervals during the day and at night. Such behaviour was noted whenever seen, and detailed observations were carried out after sprinkling the body with flour. Observations (a total of at least 60) involved nine males and one female of *D. sycorax* that emerged from the mud nest and the full repertoire of cleaning activities was seen 12 times in seven different individuals (6♀, 1♂). The terminology

used in describing the grooming behaviour is from Basibuyuk and Quicke (1999).

After sufficient observations had been made, the specimens were released into a glass terrarium (288 × 217 × 225 mm, internal measurements) with the floor covered by fine sand to a depth of 25 mm and with several flattish stones to provide hiding places. Food (a solution of 10% honey dissolved in water) and water were provided in small glass tubes plugged with cotton wool. Most specimens lived for 3–10 months, the male surviving for the shortest period (8 weeks).

## RESULTS AND DISCUSSION

### Specimens Emerging from Mud Nest of Host

The mud nest comprised 15 more or less parallel cells separated by thick walls and with the outer walls thickened and roughened by the addition of extra mud. Within 16 days after the first recorded emergence, one male (12 mm long) and nine females (12–15 mm long) of *D. sycorax*, one specimen of *Stilbum cyanurum* (Förster) (Chrysididae) and two specimens of *Sceliphron spirifex* (one of each sex) had emerged. In addition, there were two cells containing host cocoons which produced hundreds of specimens of a species of *Melittobia* (Eulophidae). The rate of parasitism was thus 87%.

### Activity Patterns of *D. sycorax*

*Emergence.*—It took approximately 10 minutes for each individual, using the mandibles, to chew its way out of the cell. The antennae, followed by the head, first emerged through the newly chewed exit hole, and the surroundings were scanned. Since the forepart of the body is often slightly narrower than the posterior part, the metasoma was often unable to pass through the hole. The process of chewing would then be resumed until the hole was large enough for the entire body to pass through. After emergence, several minutes

were spent inspecting the nest, although no attempt was made to enter a previously vacated cell ( $n = 3$ ).

*Daily activity.*—Because of the artificial conditions of the terrarium, it is impossible to assume much about daily cycles. A female was placed together with the others in the terrarium only after the male had mated or interacted with her. The only male was kept in the terrarium with the mated females and his activity, as with the females, was monitored. At night all females huddled together under the same flat stone, even though there were several others of similar shape. The male was solitary, never resting with the females. The male died after 55 days, while the females lived for approximately 6 months. One female lived for almost 11 months.

### Mating

Immediately after a male and a female were placed together in a petri dish, after having been kept in separate vials ( $n = 5$ ), they initially tried to escape by running. Whenever the two individuals came into contact head-on, both instantly showed avoidance or escape reactions by moving away in different directions. This is similar to Ferguson's (1962) observations on *Sphaerophthalma (Photopsis) blakeii* (Fox) but contrary to Brothers' (1972) observations on *Pseudomethoca frigida* (Smith) and Bayliss and Brothers' (1996) observations on *Tricholabiodes* spp. where neither member showed avoidance reactions. As soon as the male contacted the female, except when head-on, his antennae began to vibrate rapidly and continuously over her body. Within seconds he attempted to mount her. The female resisted by stridulating strongly, raising herself on her legs and flexing the apex of her metasoma slightly towards her coxae. As soon as the male began stroking her with his antennae, she became subdued, stopped stridulating and became absolutely still. Once on the female, the male continued to flicker his antennae, continuously stroking her

head and the anterior part of her mesosoma (Fig. 3). The female remained in a frozen position, with her antennae concealed under her deflexed head. After a period ranging from several seconds to a couple of minutes, depending on her reaction, the male gradually manoeuvred posteriorly on the female so that his genitalia could be inserted into her genital opening. If she became restless the stroking of her body by his antennae intensified. If she became more restless, he would quickly resume his initial more anterior position.

After moving posteriorly, the male grasped the female laterodorsally at the midlength of the first metasomal segment with his mandibles; extruding his genitalia he began prodding her genital opening with them. Often, while the male was prodding her genital opening, the female would wander around the petri dish with him still mounted on her back. If she became too agitated or began moving too quickly, the male withdrew his genitalia, disengaged his mandibles and again began stroking her with his antennae. As soon as actual genital union occurred, the female became motionless, thrusting her body forward, tucking her forelegs under her head, with the middle and hind legs placed laterally and supporting her. Her entire body was more or less straight with the metasoma lifted and the head against the substrate. Her ovipositor was extruded (Fig. 4), a condition which may be necessary for successful copulation in mutilids since it has been observed in other species (Brothers 1972, Bayliss and Brothers 1996). Genital union lasted between 60–100 seconds, during which time the male continuously stroked the female with his legs and antennae. Throughout genital union, the parameres remained outside the body of the female, lateral to her genital opening, while the rest of the male's genitalia extended into the female.

Immediately following separation of the genitalia, the male, poised posteriorly on

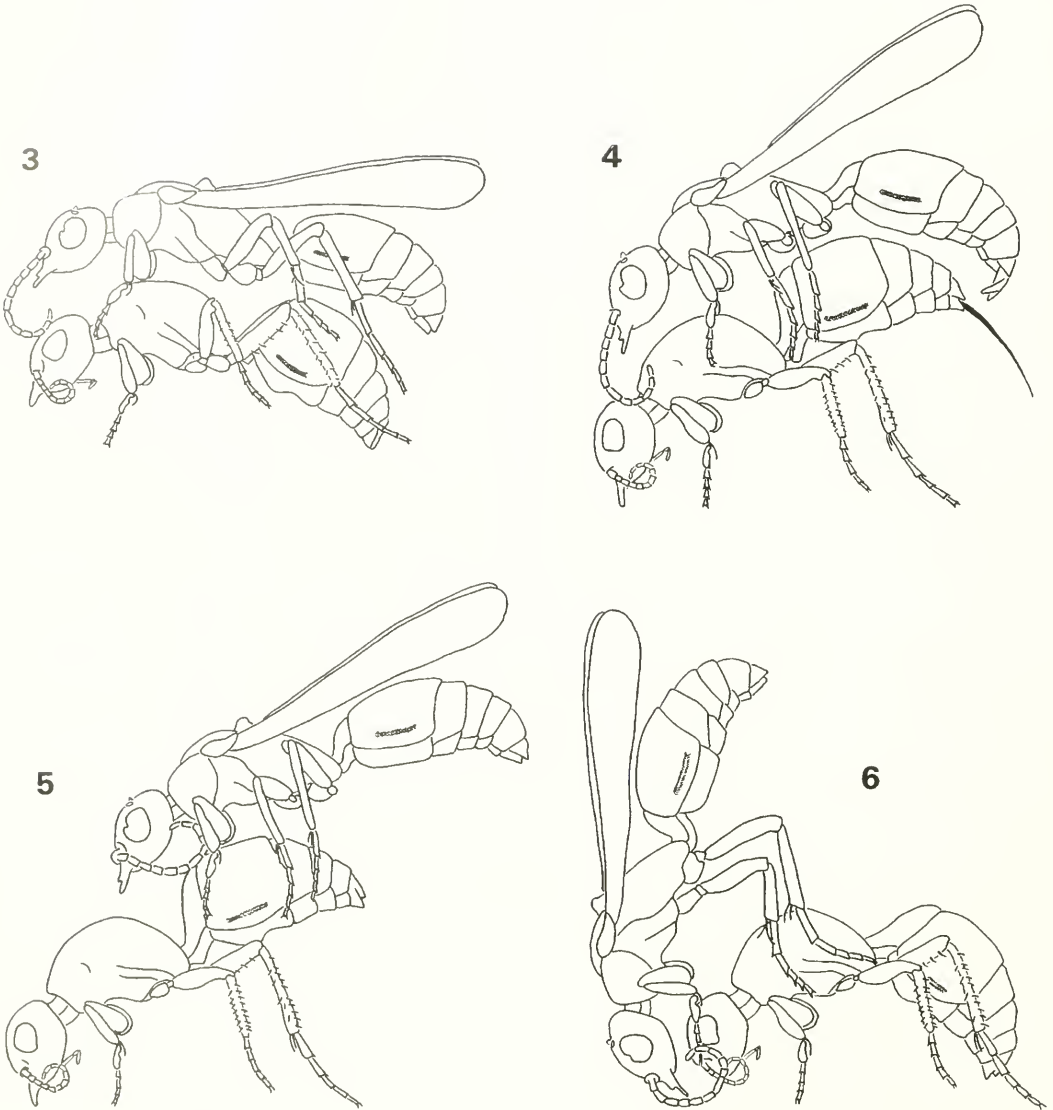

Figs. 3–6. *Dolichomitilla sycorax*, mating behaviour, diagrammatic. 3, mounted  $\delta$  stroking  $\text{♀}$  with antennae. 4, posture immediately before copulation. 5, posture immediately after copulation. 6, posture several seconds after copulation.

the metasoma of the female, extended and straightened his metasoma, thrusting the tip high into the air, and retracted his genitalia (Fig. 5). Suddenly, without warning, the male rushed forward over the female, coming to rest on her mesosoma. He dropped his head on to hers and lifted the posterior part of his metasoma high into the air, almost perpendicular to the sub-

strate, while swaying back and forth for approximately 5–10 seconds before dismounting (Fig. 6). Immediately upon genital separation the female retracted her ovipositor and bent her metasoma forward between her legs. She bent her head down and nibbled the metasomal tip with her mouthparts. This behaviour has previously been reported as unique for the

Formicidae within the Hymenoptera (Wilson 1962, Farish 1972), but has never been recorded following copulation. Its function is not obvious but, despite the fact that no extruding material could be seen, it is possible that part of the material deposited by the male is a nuptial donation which the female consumes and uses as food or as some chemical signal. The female did not extrude and withdraw her sting as observed by Brothers (1972) in *Pseudomethoca frigida*, and by Bayliss and Brothers (1996) in *Tricholabiodes* spp. After dismounting, the male usually began grooming himself thoroughly. It was several seconds before the female began to wander around the petri dish again.

In subsequent encounters immediately following mating, the male's response to the female was one of apparent hostility; he rushed at her, fluttering his wings and bumping into her from behind. After several seconds of such treatment, and with no possible escape from the petri dish, the female stopped moving and hunched up, curling her head and antennae under her body and tucking her legs against her sides. The male continued to bump her from behind, rushing at her with wings flapping, apparently attempting to drive her away. Subsequent encounters between the male and female were of shorter duration, with continued aggressive behaviour exhibited by the male towards the female. Similarly, if two previous recently mated adults were again placed together, the male immediately became aggressive towards the female, chasing her with wings fluttering and bumping her, almost pouncing on her. The male became more aggressive to the mated female the longer they were kept together. There was never an attempt by the male to mount an already mated female. As previously observed in *P. frigida* (Brothers 1972), the attractiveness of a mated female mutillid appears to diminish rapidly after mating. After several days the aggressive behaviour

of the male towards the female had vanished, with him totally ignoring her.

Unlike the situation in some other Smicromyrmina (Mutillini), some Myrmosinae and the Rhopalomutillinae (Brothers 1975, 1989), where the male often transports the female in flight before settling and mating or may even mate in flight, in *D. sycorax* no attempt was made by the male to fly and carry the female, and mating took place on the substrate in an upright position. The absence of phoretic copulation is probably because the male is about the same size as the female or even smaller.

### Grooming

There are no differences in cleaning techniques between the sexes (except for those involving the wings). If an individual is extremely dirty it first partially cleans the posterior part of the body; otherwise grooming proceeds antero-posteriorly.

*Head.*—The antennae, which are the most frequently groomed structures, are cleaned using the antenna cleaners on the front legs, either by double-antenna scraping (both antenna cleaners are simultaneously passed distad along the respective ipsilateral antenna) or single-antenna scraping (one antenna at a time is groomed by the ipsilateral antenna cleaner; the different antennae are usually groomed consecutively). During double-antenna scraping, the head remains still with each antenna placed in its antenna cleaner and then drawn between the spur and basitarsus from base to apex three to four times by movement of the forelegs. During single-antenna cleaning, the leg is lifted over the antenna which is placed in and pulled through the antenna cleaner by tilting the head backwards and simultaneously moving the leg away from the head. Sometimes, more often in the female, there is simultaneous grooming of one antenna using the antenna cleaners of both ipsi- and contralateral forelegs. The

surface of the head is cleaned by both forelegs separately or simultaneously. If the head is cleaned by only one foreleg, it is tilted to one side and brushed postero-anteriorly with short rapid strokes. The brushing of the head is usually followed by single-antenna scraping. The foreleg calcaria are used for cleaning the mandibles, while both maxillary and labial palpi are cleaned similarly to double-antenna scraping, where the palpi are either singly or simultaneously pulled rapidly through the antenna cleaner of the ipsilateral forelegs. While one foreleg is cleaning the ipsilateral antenna, the other might be cleaning the palpi.

*Body.*—Cleaning of the dorsal and lateral parts of the mesosoma was never observed. The anterior part of the mesosoma, including the neck region, is cleaned with the forelegs separately or simultaneously. The mesosternum is cleaned by the calcar and basitarsus of the foreleg; the calcar is first angled away from the basitarsus, then pushed down the length of the mesosoma between the coxae, ending with the foreleg rubbing laterally against the ipsilateral middle leg. The dorsal and lateral parts of the metasoma are cleaned by both hind legs, using alternating or simultaneous strokes. While grooming the metasoma, the wasp balances on its front two pairs of legs, with the entire body slightly arched and the wings folded dorsally. Often only one side of the metasoma is cleaned, using the ipsilateral leg. The longer tibial spur, which is that mainly used, is angled away from the tibia. The metasoma is first cleaned proximally, then sequentially more distally using longer strokes each time, the first one or two segments being cleaned before proceeding to the more distal segments. The sides are groomed first, followed by the dorsal surface and then the sterna which are cleaned by a single hind leg. While the middle and hind legs clean the metasoma, the animal balances on its head with the forelegs supporting it laterally but close to the head.

Although the hind legs are predominantly responsible for cleaning the metasoma, the middle legs might assist by making several strokes down the sides. No concentration of attention to grooming of the felt lines (laterally on the second metasomal tergum) or the metasomal apex was observed, although these areas may be sources of pheromones or other chemicals.

*Legs.*—The legs are cleaned sequentially, anterior to posterior. The fore legs, if very dirty are first rubbed against each other. The entire foreleg is then rubbed against and pulled between the spur and basitarsus of the ipsilateral middle leg. The ipsilateral middle leg is not moved. Alternatively, the fore leg is positioned ventrally along the length of the body, and the spur and basitarsus of the ipsilateral middle leg is scraped down its entire length and then shaken. Cleaning of the forelegs, in particular the tarsi and apical portions of the tibiae, using the mouthparts (otherwise known as foreleg nibbling) was never observed, although Basibuyuk and Quicke (1999) noted this as commonly occurring in Mutillidae. The middle legs are groomed separately, using the tibial spurs and basitarsi of both hind legs. The hind legs are individually cleaned by the spurs and basitarsi of the ipsilateral middle and contralateral hind legs. The hind leg remains still. A hind leg is first cleaned distally, then sequentially more proximally by cleaning a longer section each time that the other legs are rubbed against it. The hind leg used for cleaning, if very dirty, is shaken or the basitarsi of both hind legs are rubbed together.

*Wings.*—The left and right wings, like the antennae, are cleaned either separately or simultaneously, using the spur and basitarsus of the ipsilateral hind leg. This is not to be confused with ichneumonid-type wing grooming where both pairs of raised wings are groomed simultaneously between the tibia and tarsus of each respective ipsilateral hind leg (Behaviour 16

(Basibuyuk and Quicke 1999)). Unlike ichneumonid-type wing grooming, where the wings are cleaned while in a horizontal position (Basibuyuk and Quicke 1999), in *D. sycorax* the wings are orientated ventrolaterally to the metasoma. While the forewings are cleaned, the hind wings are positioned laterally, perpendicular to the body and horizontal to the substrate. The wing, while being cleaned, always remains between the body and the hind leg. While the dorsal surface of the forewing is being cleaned, the costal margin is orientated ventrally with the dorsal surface facing outwards. The metatibia and metatarsus, remaining lateral to the wing, slowly comb it in a backward-downward motion. After 3–4 strokes the hind leg is cleaned. The posterior margin of the forewing is cleaned once the dorsal surface has been combed; it is gripped and pulled between the spur and basitarsus. Thereafter the forewing is orientated so that the costal margin is dorsally placed, with the ventral surface facing outward. The ventral surface of the forewing is cleaned similarly to the dorsal surface. The hind wing is cleaned in a sequence similar to the forewing. The latter returns to a horizontal position along the body after scraping, though at a greater distance from the body than in the normal resting position. The hind wings are similarly flipped as the forewings, depending on the surface being cleaned. When the wings of both sides are being cleaned simultaneously, the animal balances on its front and middle legs, and when cleaning the wings separately, the wasp shifts its weight to either the left or right legs, arching the mesosoma away and the metasoma towards the wing that is being cleaned.

Compared with *Tricholabiodes* spp. (Bayliss and Brothers 1996), *D. sycorax* displays relatively few differences in grooming techniques but does tend to exhibit a greater repertoire of grooming behaviours.

## Host Relations

Specimens of *Dolichomutilla* have been reared from the mud nests of various host wasps (specially sphecids of the tribe Sceliphriini) and appear to be restricted to such hosts. Nonveiller (1996) gave the host of *D. guineensis* (Fabricius) (= *D. simillima* Bischoff) as an unidentified species of *Chalybion*, and that of *D. scutellifera* (André) (= *D. conigera* (André)) as an unidentified species of *Sceliphron*. Krombein & Walkley (1962) recorded *D. minor minor* Bischoff as a parasitoid of *Sceliphron spirifex*; we have seen a female specimen of *D. m. minor* collected on a *Sceliphron* nest at Mkuzi Game Reserve, KwaZulu-Natal (27°37'S, 32°14'E) on 3–6.iii.1990 by A. Weaving (DJB collection) and a female of *D. m. minor* reared from a mud nest of "*Cyphononyx antennatus* (Smith)" (Pompilidae) collected at Durban on 10.i.1945 by Marley (South African Museum collection). Weaving (1994a, 1994b, 1995) recorded the hosts of *D. heterodonta* Bischoff in KwaZulu-Natal as *Auplopus femoralis* (Arnold) (Pompilidae), *Tricarinydnerus guerinii* (Saussure) and *Afreumenes aethiopicus* (Saussure) (both Vespidae, Eumeninae), all species using mud in nest making. (The mutillid was probably misidentified, however, since that species only occurs further north.)

Péringuey (1898) reared both sexes of *D. sycorax* from the mud nests of *S. spirifex* on several occasions. Skaife (1953:325) referred to "*D. guineensis*" (actually *D. sycorax*) as having been reared from *S. spirifex*, but gave no authority for this, and may have been referring to Péringuey's specimens. (Incidentally, Skaife's figure 163, captioned as being of both sexes of *D. guineensis* "Parasitic on solitary bees" (sic), shows a male which looks like a species of *Stenomutilla* and a female which is probably a species of *Dasylabroides*.) Weaving (1994b, 1995) recorded *S. spirifex*, *T. guerinii* and *Synagris analis* Saussure (Vespidae, Eumeninae) as hosts of *D. sycorax*,

and provided considerable information on the biologies of the hosts and the influence of nest type and construction on parasitism rates. In the Albany Museum (Grahamstown) there are three female and three male specimens of *D. sycorax* reared from a nest of *S. spirifex* which also yielded one female and one male of the host and was collected by N.J. Myers at the Tobacco Research Station, Trelawney, Zimbabwe, January/February 1954 (dets F.W. Gess). In addition to these records and the same host relationship recorded in this paper, *D. sycorax* has also been reared from multicellular mud nests of a species of eumenine vespid, possibly *Delta maxillosa* (de Geer) (det. C.F. Jacot-Guillarmod) or *S. analis* (see Weaving 1995), collected by DJB at Lake Sibaya, KwaZulu-Natal on 13–25 March 1968. That nest yielded no host specimens, but produced six mutillids, five females (10–18 mm long) and one male (10 mm long). The considerable difference in sizes of individuals in this clutch is notable. The largest female has golden brown pubescence replacing the black pubescence of the other specimens and thus appears very different in coloration. (Bischoff (1920) described a similar female specimen of this species as form *aurata*, and this phenomenon was first noted by André (1899:35) for other mutillids.) The host range of *D. sycorax* is thus greater than previously thought, although in all cases mud is used for nest construction, whether as free multicellular aerial nests or forming the nest closures and cell partitions in cavity nests.

Also interesting is the fact that for two of the three nests from which multiple mutillids emerged, a single male was produced. This may indicate a tendency toward a biased sex ratio as is found in some other parasitoid hymenopterans, specially those which develop gregariously or quasi-gregariously, and which produce a single male that emerges early and mates with his sisters as they emerge (e.g. see Hardy 1994). Additional evidence is

obviously needed, but partial support may be derived from the observation that males of *Dolichomutilla* are very much rarer in collections than are females.

#### ACKNOWLEDGEMENTS

We wish to thank Ray Miller and Johan Kotze of the University of Natal (Pietermaritzburg) and the KwaZulu-Natal Nature Conservation Service for the specimens. Fred Gess of the Albany Museum kindly supplied information on specimens in his care. Financial assistance was provided by the Foundation for Research Development and the University of Natal Research Committee.

#### LITERATURE CITED

- André, E. 1899–1903. Les Mutillides. *Species d'Hyménoptères d'Europe et d'Algérie* 8:1–479, pl. 1–XV.
- Basibuyuk, H. H. & D. L. J. Quicke. 1999. Grooming behaviours in the Hymenoptera (Insecta): potential phylogenetic significance. *Zoological Journal of the Linnean Society* 125: 349–382.
- Bayliss, P. S. & D. J. Brothers. 1996. Biology of *Tricholabiodes Radoszkowski* in southern Africa, with a new synonymy and review of recent biological literature (Hymenoptera: Mutillidae). *Journal of Hymenoptera Research* 5: 249–258.
- Bischoff, H. 1920–21. Monographie der Mutilliden Afrikas. *Archiv für Naturgeschichte* 86(A): 1–830, 1 map.
- Brothers, D. J. 1972. Biology and immature stages of *Pseudomethoca f. frigida*, with notes on other species (Hymenoptera: Mutillidae). *University of Kansas Science Bulletin* 50: 1–38.
- Brothers, D.J. 1975. Phylogeny and classification of the aculeate Hymenoptera, with special reference to Mutillidae. *University of Kansas Science Bulletin* 50: 483–648.
- Brothers, D. J. 1989. Alternative life-history styles of mutillid wasps (Insecta, Hymenoptera), pp. 279–291. In Bruton, M.N. ed., *Alternative Life-History Styles of Animals*, Kluwer Academic Publishers, Dordrecht.
- Farish, D. J. 1972. The evolutionary implications of qualitative variation in the grooming behaviour of the Hymenoptera (Insecta). *Animal Behaviour* 20: 662–676.
- Ferguson, W. E. 1962. Biological characteristics of the mutillid subgenus *Photopsis* Blake and their systematic values. *University of California Publications in Entomology* 27: 1–91.
- Gerstaecker, [A.] 1857. [Descriptions.] In: Peters, Übersicht der von ihm in Mossambique aufgefundenen und von Hrn. Dr. Gerstaecker bearbeiteten Hymenopteren aus den Familien der Crabronites, Sphegidae, Pompilidae und Heterogy-

- na. *Monatsberichten Akademie der Wissenschaften Berlin* 1857, pp. 509–513.
- Gerstaecker, A. 1862. Hymenoptera, Hautflügler. In: Peters, *Naturwissenschaftliche Reise nach Mossambique auf Befehl seiner Majestät des Königs Friedrich Wilhelm IV in den Jahren 1842 bis 1848 ausgeführt. Zoologie, V. Insecten und Myriopedes*. Reimer, Berlin. pp. 438–526.
- Hardy, I. C. W. 1994. Sex ratio and mating structure in the parasitoid Hymenoptera. *Oikos* 69: 3–20.
- Krombein, K. V. & L. M. Walkley. 1962. Three hymenopterous parasites of an African mud-dauber wasp, *Sceliphron spirifex* (L.) (Hymenoptera). *Proceedings of the Entomological Society of Washington* 64:78.
- Nonveiller, G. 1996. Remarques sur *Dolichomutilla guineensis* (F., 1793) *Dolichomutilla sycorax* (Smith, 1855) et sur certains hôtes du genre *Dolichomutilla* Ashmead, 1899 [Hymenoptera, Mutillidae]. *Revue française d'Entomologie* 18: 31–34.
- Péringuey, L. 1898. Description of some new or little known South African Mutillidae in the collection of the South African Museum. *Annals of the South African Museum* 1: 33–94.
- Skaife, S. H. 1953. *African Insect Life*. Longmans Green, London etc.
- Weaving, A. J. S. 1994a. Notes on nesting behaviour in two Afrotropical auopline wasps, *Auplopus vitripennis* Smith and *A. fenoralis* (Arnold) (Hymenoptera: Pompilidae). *The Entomologist* 113: 140–153.
- Weaving, A. J. S. 1994b. Nesting behaviour in three Afrotropical trap-nesting wasps, *Chalybion laevigatum* (Kohl) *Propeipona meadewaldoi* Bequaert and *Tricarinosdymerus guerini* (Saussure), (Hymenoptera: Sphecidae, Eumenidae). *The Entomologist* 113: 183–197.
- Weaving, A. J. S. 1995. A comparison of nesting success and nesting habits in some Afrotropical aculeate wasps, with particular reference to nest parasites (Hymenoptera: Sphecidae, Eumenidae). *Annals of the Cape Provincial Museums (Natural History)* 19: 181–224.
- Wilson, E. O. 1962. Behavior of *Daceton armigerum* (Latreille), with a classification of self-grooming movements in ants. *Bulletin of the Museum of Comparative Zoology* 127: 401–422.

## The Number of Sex Alleles (CSD) in a Bee Population and its Practical Importance (Hymenoptera: Apidae)

GISELE ALMEIDA CARVALHO

Departamento de Genética da Faculdade de Medicina de Ribeirão Preto da Universidade de São Paulo, Ribeirão Preto, São Paulo, Brazil

---

*Abstract.*—This work was carried out to monitor the number of *xo* sex alleles (CSD—Complementary Sex Determination) in a limited population of *Melipona scutellaris* Latreille (Apinae, Meliponini) and to verify if introduction of inseminated queens from distant populations is a good and practical method to avoid extinction of small ones. Twenty-two colonies of *Melipona scutellaris* were brought from Lençóis, Bahia (12°34'S; 41°23'W) to Uberlândia (18°52'56"S; 48°12'55"W), 500km south of the southern edge of its geographical distribution. Thirty foreign queens were introduced from 1992 to 1995, and the number of *xo* sex alleles oscillated from 7.0 to 36.0. The number of sex alleles was studied using a formula modified from the one of Laidlaw *et al.* (1956)  $n = 2M(N+1)/(H+1)$  (where *n* is the number of *xo* sex alleles in the population, *N* is the total number of colonies sampled of this population, *H* is the number of colonies that produced diploid males and *M* is the number of males that mated with the queen). These results showed that the introduction of inseminated queens serves to maintain the variability of sexual alleles and, consequently, allow the existence of small populations of Meliponini. These data are being taught to *Melipona* beekeepers to improve their bee yards and help in protecting the species from extinction.

---

Brazilian stingless bees (Hymenoptera, Apidae) are among the main pollinators of the native Brazilian flora, varying from 30% to 90% of the native plants, according to the ecosystem they inhabit (Kerr *et al.* 1994). These bees belong to the subfamily Apinae, tribe Meliponini, and at least three species, *Melipona scutellaris* Latreille, *M. compressipes fasciculata* Smith and *M. beecheii*, were domesticated by native Pre-colombian populations, two in Brazil (Maranhão and Pernambuco States) and one in Mexico (Yucatan). Besides being good pollinators, two bees, the African honey bee and Uruçu (*Melipona scutellaris*) are the main producers of honey in northeastern Brazil. *Melipona* honey reaches a price 4 to 10 times higher than honey bees because of lower production by individual colonies and the preference of local populations.

More than 350 species of Meliponini are distributed in the Tropical and Subtropical

Zones of South and Central Americas, Malaysia, India, Indonesia, Africa and Australia. Unfortunately about 100 species of stingless social bees are being seriously threatened with extinction as a consequence of the current forest destruction. In Brazil, annual deforestation increased 20% in the last 3 years due to the arrival of Chinese and Malaysian lumber companies.

Besides the forest destruction that is accompanied by both forest fires and plantations of grass, soybean, rubber trees, guarana, pepper, Brazil nuts and tropical fruits, there is the serious problem of CSD (Complementary Sex Determination) that in bee happens with one main gene (*xo*-sex alleles). According to Mackensen (1951) sex in *Apis mellifera* is determined by *xo* sexual alleles, where heterozygous larvae become females, hemizygous are males and homozygous are diploid males. This genetic system by *xo*-sex alleles de-

Table 1. Production of males in colonies of *Melipona scutellaris* and estimates  $x_0$  alleles using  $n = 2M(N + 1)/(H + 1)$  where  $n$  = number of  $x_0$ ,  $N$  is the total number of hives,  $H$  is the number of hives that produced 50% diploid drones and  $M$  is the number of males that inseminated the queen.

Year of sampling	Total number of colonies in <i>Melipona</i> apiary in each year	Number of colonies sampled	Number of colonies produced 100% of female	Number of colonies that produced 50% female:50% male (mated with one male)	Number of colonies that produced 75% female:25% male (mated with two males)	Estimated number of $x_0$ CSD alleles
1991	50	13	9	1	3	24.5
1992 (a)	80	27	19	7	1	7.86
1993 (b)	72	15	12	3	0	8.00
1994 (c)	79	16	13	1	2	28.34
1995 (d)	66	8	7	0	1	36.00
1997	65	7	5	1	1	12.00
1998	70	9	7	1	1	15.00
1999	60	29	23	5	1	11.67
Total	—	124	95	19	10	23.86

(a) introduction of 13 queens of Piatã, BA (14 June 1992)

(b) introduction of 3 queens of Catu, BA (19 July 1993)

(c) introduction of 11 queens of Lençóis, BA (24 May 1994)

(d) introduction of 3 queens of Lençóis, BA (26 March 1995)

termination is named "Complementary Sex Determination" (CSD) and was first described in the parasitoid wasp *Bracon hebetor* by Whiting (1943). He proposed that sex was regulated by a series of alleles segregating at a single locus. Camargo (1979) found the same CSD genetics for *Melipona quadrifasciata*, Kerr (1987) for *M. compressipes fasciculata*, and Carvalho *et al.* (1995) for *M. scutellaris*.

Kerr (1987) and Kerr *et al.* (1988) proposed that the  $x_0$  gene of primitive populations is still found in endogamous populations of Hymenoptera. It is mutated rarely, but constantly, to  $x_0^1$ ,  $x_0^2$ , ...  $x_0^{20}$  which were selected in panmitic populations giving origin to a series of multiple alleles that are involved in sex determination (CSD).

Yokoyama and Nei (1979) and Cornuet (1980) have shown that the number of CSD alleles maintained in a limited bee population depends directly on its size. Woyke (1980) demonstrated that in *Apis mellifera* the minimum number of CSD alleles that allows a population to survive is six. Our experience with three *Melipona* species indicates that six is also the minimum number of  $x_0$  alleles required to

maintain restricted populations. Bellow six the population decreases rapidly due to the formation of diploid males. Stouthamer *et al.* (1992) and Heimpel *et al.* (1999) also observed the same in some hymenopteran parasitoids.

Unlike *Apis mellifera* queens that mate with 17 to 15 males (respectively Adams *et al.* 1977, Lobo and Kerr 1993), queens of stingless bees (*Meliponini*) mate with one or two males, rarely more (Kerr 1969, Contel and Kerr 1976, Paxton *et al.* 1999). Our data with *Melipona scutellaris* showed about 8% of crosses occurred with 2 males (Table 1). In small populations of *Melipona* with 6  $x_0$  alleles,  $\frac{1}{3}$  of the new colonies will produce diploid males (Kerr and Vencovsky 1982). Many known panmitic Hymenoptera have  $x_0^n$  sex alleles and have developed different methods to avoid the production of triploid females: a) in many Hymenoptera diploid males are semi-lethal or almost sterile (Inaba 1939, MacBride 1946, Hung *et al.* 1974, Naito and Suzuki 1991, Stouthamer *et al.* 1992, El Agoze *et al.* 1994); b) in *Apis mellifera* the workers eat the diploid male larvae (Woyke, 1980); c) in *Melipona* soon after they emerge from the brood cells, workers kill both diploid

males and the inseminated queen that is producing them (Camargo 1979, Kerr 1987, Kerr *et al.* 1996); d) increasing the number of *xo*-alleles and e) multiple mating diminishes the genetic load effect of 2n males.

Adams *et al.* (1977) and Lobo and Kerr (1993) respectively estimated the number of *xo*-alleles for open populations of *Apis mellifera* at 18.9 and 15.7, and Kerr (1987) in *Melipona compressipes* found it was 20.0. Using data based in the formula of Cornuet (1980), Kerr and Vencovsky (1982) estimated that in order to maintain 6 *xo*-alleles, the *Melipona scutellaris* population must contain 44 colonies or more. If the number of colonies is below 44 this whole mini-population is bound to be eliminated in a few generations. Carvalho *et al.* (1995) cited many examples of the extinction of small populations of stingless bees. This means that the decline of the number of *xo* sex alleles in stingless bees (Meliponini) is fatal and leads a population and even the species to elimination. Falk (1991) emphasized the fact that there is a worrying decline in the Aculeate population in Great Britain, with nearly half of the species described considered to be under threat. Of course, there is a genetic load associate with CSD sex determination in bees as it was demonstrated by Kerr (1975) and Werren (1993).

The objective of the research presented in this paper was to monitor the number of *xo* alleles year by year in a limited population of *Melipona scutellaris* and to study the effect of the introduction of inseminated queens in this population. Descendants of 22 colonies that came from the forests near Lençóis (Bahia) were maintained in Uberlândia (18°52'56"S; 48°12'55"W) about 500 km South of the southern border of its natural distribution, that is, there was no feral population of *Melipona scutellaris* within a radius of 500 kilometers of Uberlândia.

## MATERIALS AND METHODS

The following material was used: 22 colonies of *Melipona scutellaris* collected randomly in the forest that surrounds Lençóis (12°34"S; 41°23"W), Chapada Diamantina, Bahia, Brazil—14 hives in 1988 and 8 hives in 1990. These colonies were divided and from their descendents 124 were sampled to be monitored. In order to count the number of *xo*-alleles the technique of Kerr (1987) was used, that is: take one or two brood combs with young bees of a given colony and put it in the place of the mother colony to receive the adult bees. In 1 to 10 days, one or several virgin queens emerge; four days after emerging one makes the nuptial flight and is inseminated. After 5 to 15 days the new queen begins egg laying. I marked this queen on her thorax. When the oldest brood comb of this new queen contains pupae, a small piece of it is taken (with about 10 to 30 pupae) and the number of workers, queens and males is counted. If the proportion fits 1:1 females: males, it indicates 50% production of diploid drones and is indication of insemination by one male only. Diploid males are confirmed by cytological analysis (diploid males have 18 chromosomes). If 25% males were produced it indicated that two males had inseminate this queen and if it was 12.5% three matings were indicated. Then the data are analyzed using the Laidlaw *et al.* (1956) formula  $n = 2M(N+1)/(H+1)$  that is better than  $n = 2MN/H$ ; in both equations *n* is the number of *xo* sex alleles in the population, *N* is the total number of colonies sampled in this population, *H* is the total number of colonies sampled that produced diploid males and *M* is the number of males that inseminated the queen. This formula assumes that the *xo* alleles have equal frequency, that there is random mating, and there is less bias in populations smaller than 10. Fisher's test was used to analyze the variation of *xo* alleles frequency by year. In order to mea-

sure the effect of the introduction of genetic material from outside the Uberlândia population as a search for a method of controlling the appearance of diploid males in small apiaries, 30 introductions of inseminated queens in orphaned colonies were carried out and these were: 13 queens of Piatã (Bahia) on 14 May 1992, 3 queens of Catu (Bahia) on 19 July 1993, 11 queens of Lençóis (Bahia) on 24 May 1994 and 3 queens of Lençóis (Bahia) on 26 March 1995. The mortality of egg and larvae of diploid males is near zero.

## RESULTS

One hundred and twenty four samples of the new colonies made were taken from the *Melipona* apiary of which 95 had 100% females in the first series of eggs laid by the new queen, 19 presented about 50% diploid drones and 10 about 25%; none produced 12.5%. The results of these samples taken during 8 years are in Table 1.

This data demonstrated that 65.5% of mating occurred with one male and 34.5% with 2 males. Then, the number of *xo* alleles in this population is 8.18 (when queen mates with one male that has the same allele as she does) and 15.68 (when two males—one with the same allele and another with different allele) totaling 23.86 *xo* alleles.

Table 1 demonstrates the variation of *xo* alleles in this population as a consequence of sampling and matings with drones produced in this same population. As these colonies were divided (in order to increase our population) since their introduction (1990), the probability that one queen mates with a drone that has the same allele is high because the population is small. The population in Uberlândia was formed of colonies from a native population in Bahia, and the number of alleles in that original population was expected to be about 20 (Kerr and Vencovsky 1982). In our 67 colonies (average per year) the average number of alleles was 16.67. Looking at the data of 1991 to 1999, the number

of sex alleles does not differ statistically between these years (Fisher's Test,  $P > 0,05$ ), which indicates the value of our method to avoid diminution of these alleles.

## DISCUSSION

The behavior of stingless bee workers killing both diploid males and the queen is how they control the appearance of 2n males. It causes many beekeepers and bee scientists who collect and maintain less than 44 hives per species to lose all or almost all in short periods of time. Four examples are: a) W. E. Kerr collected 14 hives, in Parnaíba, SP, Brazil, of *Melipona marginata* in 1945. Six years later all had died; b) He collected 12 hives, in 1944, of *Melipona quadrifasciata* (also in Parnaíba, SP). In 1955 all had died; c) Eng. Agr. Rogério M. O. Alves collected 11 colonies of *M. quadrifasciata* near Catu, Bahia, Brazil, in May 1990; by December 1991 he had eight colonies, and in June 1993 only one was left; d) Mr. Alvino Pianzolli collected 20 colonies of urucu-preto (*Melipona capixaba*) in Domingos Martins, Espírito Santo, Brazil in 1973. In June 1993, he still had 8, because the forest is not very far from the meliponary, so that his queens can mate with males from the forest. The same case was observed by Nascimento *et al.* (1996) at Archipelago of Fernando de Noronha (Pernambuco, Brazil) for three species of *Melipona*. They found, in 1996, only 18 colonies of *M. compressipes* out of 32 introduced, 11 of *Melipona subnitida* in 10 and none of *M. scutellaris* in 30 introduced in 1982 by Kerr and Cabeda (1985). These examples confirm the observations of Yokoyama and Nei (1979) about the extinction of small populations, and suggest the necessity of methods to avoid the decline of variability of sexual alleles.

The introduction of 13 foreign queens in 1992 and 3 in 1993 did not show its effect in the same year—the data show a decline in the number of alleles in 1992 and 1993. Due to the winter that followed the intro-

ductions of 1992 and 1993, the colonies usually became weaker than in the rest of the year and there was no regular production of males. Therefore, these introduced queens will be genetically active through their males only for the next queens naturally superseded.

When the queens were introduced in June or July (winter in the Southern Hemisphere) there were few or no males, but when they were introduced in May or March, the last season in which males are being produced, an apparent increase of the number of *xo* sex alleles was detected, reaching a value of  $n = 17.92$ , which is close to the values obtained by Kerr (1987) and Carvalho *et al.* (1995) for two *Melipona* species. Looking at the results of 1997 to 1999, it appears to indicate a small decline in the number of *xo* alleles. As the statistical analysis (Fisher's Test) showed, there was no divergence among the number of alleles by year, indicating that the introduction of these queens maintained the genetic variability in the population in Uberlândia, thus avoiding the appearance of diploid males and the extinction of their population.

Our data showed that the introduction of 3 to 4 inseminated queens per year in an apiary with about 65 colonies improved the genetic variability of the *xo* alleles becoming a good alternative to avoid the production of diploid males. It can save the production of hundreds of beekeepers who maintain small meliponaries because the production and sale of inseminated queens is much easier than selling a complete bee colony.

The main conclusion is: the method of introduction of 3 to 4 inseminated queens by year is good to avoid low sex allele diversity and consequent production of diploid males (the Yokoyama and Nei effect); it maintains the variability of *xo* sexual alleles and consequently allows the existence of restricted populations of *Meliponini ex-situ*, that is outside their area of geographic distribution.

## ACKNOWLEDGMENTS

I thank Prof. Warwick Estevam Kerr for the advices provided during this seven years work; Prof. Gismar Silva Vieira for helping in statistical analysis, Prof. Rogério Marcos de Oliveira Alves for providing queens from Catu, BA; Mr. José Carlos Moraes for queens from Lençóis, BA. I thank Ms. Vania Alves Nascimento for her help in the cytological examinations. My acknowledgments are also to an anonymous referee that made important suggestions. CNPq (Conselho Nacional de Pesquisa e Desenvolvimento Tecnológico), FAPEMIG (Fundação de Amparo a Pesquisa de Minas Gerais) and Bank of Brazil Foundation provided the financial support.

## LITERATURE CITED

- Adams, J., E. D. Rothman, W. E. Kerr, and Z. L. Paulino. 1977. Estimation of the number of sex alleles and queen matings from diploid male frequencies in a population of *Apis mellifera*. *Genetics* 86: 583-596.
- Camargo, C. A. 1979. Sex determination in bees. Production of diploid males and sex determination in *Melipona quadrifasciata*. *Journal of Apicultural Research* 18 (2): 77-84.
- Carvalho, G. A., W. E. Kerr, and V. A. Nascimento. 1995. Sex determination in bees. XXXIII. Decrease of *xo* heteroalleles in a finite population of *Melipona scutellaris* (Apidae, Meliponini). *Brazilian Journal of Genetics* 18 (1): 13-16.
- Contel, E. P. B. and W. E. Kerr. 1976. Origin of males in *Melipona subnitida* estimated from data of an isozymic polymorphic system. *Genética* 46 (3): 271-277.
- Cornuet, J. M. 1980. Rapid estimation of the number of sex alleles in panmictic honeybee populations. *Journal of Apicultural Research* 19: 3-5.
- El Agoze, M., J. M. Drezen, S. Renaulst, and G. Periquet. 1994. Analysis of the reproductive potential of diploid males in the wasp *Diadromus pulchellus* (Hymenoptera: Ichneumonidae). *Bulletin of Entomological Research* 84: 213-218.
- Falk, S. 1991. A review of the scarce and threatened, wasps and ants of Great Britain. Peterborough, UK; Nature Conservancy Council for England. *Research and Survey in Nature Conservation* N°35, ii + 344pp. (*Apicultural Abstracts* 1992, vol. 43 (3): 196-197).
- Heimpel, G. E., M. F. Antolin, and M. R. Strand. 1999. Diversity of Sex-determining alleles in *Bracon hebetor*. *Heredity* 82: 282-291.
- Holloway, A. K., G. E. Heimpel, M. R. Strand, and M. F. Antolin. 1999. Survival of Diploid Males in *Bracon* sp near *hebetor* (Hymenoptera: Braconidae). *Annals of the Entomological Society of America* 92 (1): 110-116.
- Hung, A. C. F., S. B. Vinson, and J. W. Summerlin.

1974. Male sterility in the red imported fire ant, *Solenopsis invicta*. *Annals of the Entomological Society of America* 67: 909-912.
- Inaba, F. 1939. Diploid males and triploid females of the parasitic wasp *Habrobacon pectinophorae* Watanabe. *Cytologia* 9: 517-534.
- Kerr, W. E. 1969. Some aspects of the evolution of social bees (Apidae). *Evolutionary Biology* 3 (4): 119-175.
- Kerr, W. E. 1975. Population genetics studies in bees (Apidae, Hymenoptera) I. Genetic load. *Anais da Academia Brasileira de Ciências* 47 (2):319-334.
- Kerr, W. E. 1987. Biologia, manejo e genética de *Melipona compressipes fasciculata* Smith (Hymenoptera: Apidae). *Tese de Professor Titular*. UFMA. São Luis (MA), 141 pp.
- Kerr, W. E. and M. Cabeda. 1985. Introdução de abelhas no território de Fernando de Noronha. *Ciência e Cultura* 37 (3): 467-471.
- Kerr, W. E. and R. Vencovsky. 1982. Melhoramento genético em abelhas. I. Efeito do número de colônias sobre o melhoramento. *Brazilian Journal of Genetics* 5: 279-285.
- Kerr, W. E., S. G. Monteiro, and H. A. S. Kerr. 1988. Sex determination in bees. XXV. Adaptive value of the *xo* gene in its origin. *Brazilian Journal of Genetics* 11 (2): 469-473.
- Kerr, W. E., V. A. Nascimento, and G. A. Carvalho. 1994. Há Salvação para os Meliponíneos? *Anais do 1º Encontro Sobre Abelhas, de Ribeirão Preto* 1: 60-65.
- Kerr, W. E., G. A. Carvalho and V. A. Nascimento. 1996. *Abelha Uruçu: Biologia, Manejo e Conservação*. Ed. Fundação Acangaú, Belo Horizonte, MG. 144 pp.
- Laidlaw, H. H., F. P. Gomes, and W. E. Kerr. 1956. Estimation of the number of lethal alleles in a panmictic population of *Apis mellifera*. *Genetics* 41 (2): 179-188.
- Lobo, J. A. and W. E. Kerr. 1993. Estimation of the number of matings in *Apis mellifera*, extensions of the model and comparison of different estimates. *Ethology, Ecology and Evolution* 5: 337-345.
- Macbride, D. H. 1946. Failure of sperm of *Habrobacon* diploid males to penetrate the eggs. *Genetics* 31: 224.
- Mackensen, O. 1951. Viability and Sex determination in the honey bee *Apis mellifera*. *Genetics* 36: 500-509.
- Naito T. and H. Suzuki. 1991. Sex determination in the sawfly *Athalia rosaruficornis* (Hymenoptera): occurrence of triploid males. *Journal of Heredity* 82: 101-104.
- Nascimento, V. A., G. A. Carvalho, L. M. Cavalcante, and W. E. Kerr. 1996. Introdução de abelhas no arquipélago de Fernando de Noronha. 4. A população de abelhas após uma década. *Anais do II Encontro sobre abelhas de Ribeirão Preto* 2: 209-216.
- Paxton, R., N. Weibschuh, W. Engels, K. Hartfelder, and J. G. Quezada-Euan. 1999. Not only single mating in stingless bees. *Naturwissenschaften* 86: 143-146.
- Stouthamer, R., R. F. Luck, and J. H. Werren. 1992. Genetics of sex determination and the improvement of biological control using parasitoids. *Environmental Entomology* 21: 427-435.
- Werren, J. H. 1993. The evolution of inbreeding in haplodiploid organisms. In: Thornhill, N. W. (ed.), *The Natural History of Inbreeding and Outbreeding*, p. 42-59, University of Chicago Press, Chicago, IL.
- Whiting, P. W. 1943. Multiple alleles in complementary sex determination of *Habrobacon*. *Genetics* 28: 365-382.
- Woyke, J. 1980. Effect of sex allele homo-heterozygosity on honeybee colony populations and their honey production. I. Favorable development conditions and unrestricted queens. *Journal of Apicultural Research* 19 (1): 51-63.
- Yokoyama, S. and M. Nei. 1979. Population dynamics of sex determining alleles in honey bees and self-incompatibility alleles in plants. *Genetics* 91: 609-626.

## Distribution and Ethology of *Priscomasaris* Gess (Hymenoptera: Vespidae: Masarinae: Priscomasarina) in Namibia

SARAH K. GESS

Albany Museum, Grahamstown, 6139 South Africa

---

*Abstract.*—Knowledge of the distribution and flower associations of the monospecific genus *Priscomasaris* is expanded. The nature of the provision, nesting situation, nest structure, and method of nest construction are recorded for the first time. *Priscomasaris namibiensis* Gess has been encountered solely in the Mopane Savanna/Northern Namib transition and Dwarf Shrub Savanna (of Giess 1971), all records falling within the northwestern extension of the Nama Karoo Biome (of Rutherford and Westfall 1986, as adapted by Lovegrove 1993). Flowers visited for nectar and pollen are of the families Aizoaceae (non-Mesembryanthema) and Molluginaceae. Nesting aggregations were located in sparsely vegetated areas of horizontally presented, stabilized, sandy soil. The nest is a multicellular burrow with its entrance surmounted by a mud-turret and with each excavated cell containing a constructed mud-cell. Water is used in excavation and construction. Evidence for bivoltinism is presented.

---

F.W. Gess (1998) described *Priscomasaris namibiensis* Gess, a new genus and species of Masarinae (Hymenoptera: Vespidae) from Namibia. He discussed its position within the subfamily, placing it in a new subtribe Priscomasarina, a sister group of Paragiina and Masarina combined. Its ethology is of particular interest as it represents the most primitive extant member of the Masarinae. F.W. Gess recorded female water collection behaviour and two forage plants but, as nests had not yet been discovered, could make no comment on nesting behaviour other than to suggest that water is most probably used in nest construction.

In March 2000 two nesting aggregations of *P. namibiensis* were discovered and investigated by the present author. This investigation forms the subject of the present paper.

*Distribution.*—Previously published (F.W. Gess 1998) and new collection records of *P. namibiensis* are listed in Appendix 1 under the vegetation types of Giess (1971) (Fig. 1) and biomes of Rutherford

and Westfall (1986) as adapted by Lovegrove (1993) (Fig. 2). It appears that *P. namibiensis* is a northern Nama Karoo species.

*Nesting areas and sites.*—Two nesting areas of *P. namibiensis* were located, both in Dwarf Savanna Shrub to the east of the Mariental-Keetmanshoop road and railway track: one 5 km south of Mariental (Fig. 3) and the other 7 km south of Gibeon railway siding. Both areas are associated with drainage lines that form part of the Fish River catchment. Rainwater pools, resulting from thundershowers, were present in association with the railway embankment through which the drainage channels have passage (Fig. 4).

The nests were aggregated above normal flood level within sparsely vegetated sites. In the Gibeon nesting area two small aggregations were discovered, each of no more than 10 nests, 9 to 11 metres from the water source. The soil was compacted sand with an inclusion of small pebbles and with a sufficient clay element to make it maleable when mixed with water. The

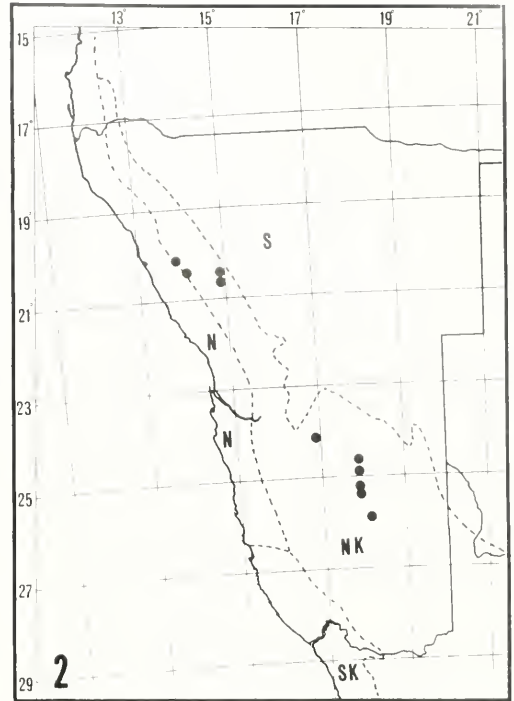
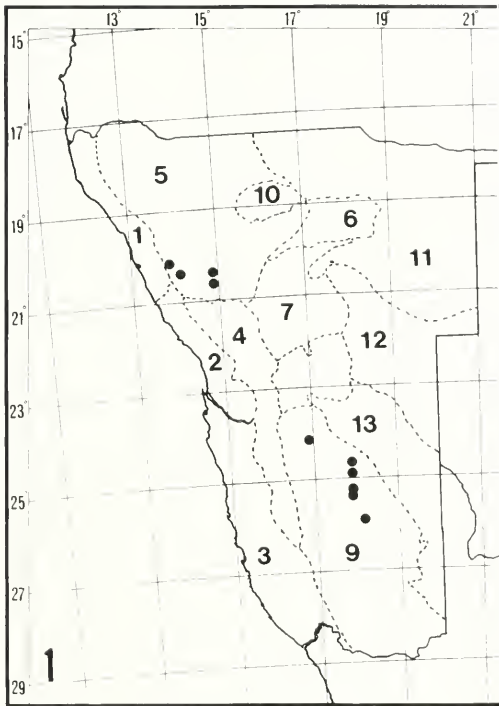

Figs. 1-2. Map of Namibia showing the distribution, based on collection records (Appendix 1), of *Prisco-sarhis namibiensis* (dots). 1, The vegetation types of Giess (1971): 1 = Northern Namib; 2 = Central Namib; 3 = Southern Namib; 4 = Semi-desert and Savanna Transition (Escarment Zone); 5 = Mopane Savanna; 6 = Mountain Savanna and Karstveld; 7 = Thornbush Savanna; 8 = Highland Savanna; 9 = Dwarf Shrub Savanna; 10 = Saline Desert with Dwarf Shrub Savanna Fringe; 11 = Tree Savanna and Woodland; 12 = Camelthorn Savanna (Central Kalahari); 13 = Mixed Tree and Shrub Savanna (Southern Kalahari). 2, The biomes of Rutherford and Westfall (1986) as adapted by Lovegrove (1993) (S = Savanna; N = Namib Desert; SK = Succulent Karoo; NK = Nama Karoo).

gravelly surface was scattered with pebbles and small plants. Individual nests were sited next to a pebble or small plant (Figs. 5-10).

In the Mariental nesting area numerous nests were distributed over a site c 100 metres square. The soil was compacted sand of an even consistency with a sufficient clay element to make it malleable when mixed with water. The surface was compacted sand scattered with an occasional pebble and "mat" plant. Most commonly nests were grouped beneath or between the spreading branches of semi-prostrate *Gisekia africana* (Lour.) Kuntze (Molluginaceae) (Fig. 16), a forage plant of *Prisco-sarhis*, and of a "mat" forming species of *Indigofera* (Papilionaceae), the flow-

ers of which it does not visit (Fig. 17). Less commonly nests were exposed but were then positioned next to a pebble or small plant.

*Water collection.*—As stated by F.W. Gess (1998) females visit pools of water in drainage channels and river beds in order to obtain water, apparently for use in nest construction. When they were common, very large numbers were present on and flying over the water. When filling their crops they always alight on the water surface, never at the water's edge. Whilst on the water surface the wings are held erect.

*Flower visiting.*—Both sexes of *P. namibiensis* visit flowers. Those recorded were all small shallow flowers of Molluginaceae and Aizoaceae. The Molluginaceae were



Figs. 3-4. Nesting area south of Mariental (24.40S 17.57E). 3, Habitat. 4, Water source.

pink flowered *Gisekia africana* (Lour.) Kuntze (Fig. 16) (between Palm and Khorixas) and white flowered *Limeum* of three species: *L. argute-carinatum* Wawra & Peyr. (Fig. 12) (west of Khorixas, between Khorixas and Uis, and south of Mariental), *L. myosotis* H. Walter (Fig. 13) (between Khorixas and Uis), and *L. sulcatum* (Klotsch) Hutch. (Fig. 11) (southwest of Bullsport). The Aizoaceae (non-Mesembryanthema) were purplish-pink flowered *Sesuvium sesuvioides* (Fenzl) Verdc. (Fig. 15) (south of Mariental) and pink and white flowered *Trianthema parvifolia* E. Mey. ex Sond. (Fig. 14) (also south of Mariental). All yield nectar, easily imbibed by this short "tongued" wasp, and pollen, requiring no specialized "harvesting" behaviour. Other plants in flower at the foraging sites were not visited.

*Priscomasaris* is not the sole visitor to the flowers of any of its forage plants. The Molluginaceae are widespread and are visited by a range of wasps and bees (Gess and Gess unpublished catalogue of flowers visited by aculeate wasps and bees in semi-arid areas in southern Africa). The Aizoaceae attract a narrow range of wasps and bees—*S. sesuvioides* is principally visited by *Ceramius damarinus* Turner (Vespidae: Masarinae), which uses it as its source of provision for its nests (S.K. Gess 1999), and a species of *Parafidelia* (Fidelidae). *T. parvifolia* is principally visited by *Quartiniella turneri* Schulthess and several *Quartinia* species.

At the site near Bullsport, where *Priscomasaris* males and females were visiting the flowers of *L. sulcatum*, some males and an occasional female were collecting nectar from the extrafloral nectaries of young plants of the herb *Chamaesyce glandulifera* (Pax) Koutnik (Euphorbiaceae).

*Provision.*—The cell provision consists of a compact, firm, roughly cylindrical mass of pollen and nectar, rounded at the ends and with undulations along its length indicating deposition of individual "loads" of the pollen and nectar mixture. The pro-

vision mass, a "pollen loaf", remains loose within the cell. One complete "pollen loaf" was 8.17 mm in length and 3.0 mm in diameter (i.e. 0.12 mm less than the inner diameter of the constructed mud-cell). Samples of pollen from provision masses collected on 10, 22 and 31 March, and 2 April were examined microscopically. Four distinct pollens of 17.5, 20, 25 and 30 micromillimetres in diameter were present. These were compared with pollens from flowers visited by *Priscomasaris* and were found to match those of *T. parvifolia*, *L. argute-carinatum*, *G. africana* and *S. sesuvioides* respectively. The proportions of the different pollens varied. Samples taken on 22 March were mostly of *G. africana* and *S. sesuvioides* and those taken on 31 March and 2 April were principally of *T. parvifolia*.

*Male behaviour.*—No males were found in nests or at water. In the morning, before the appearance of the females, males were observed flying to and fro over nesting aggregations and visiting flowers. After the females had made their appearance males were observed mounting them, both on the ground in the vicinity of the nests and on flowers. It was not possible to observe copulation.

*Description and method of nest construction.*—The description of the nest of *P. namibiensis* is based on investigations of 62 nests: four in the Gibeon nesting area on 9 March; and 22, 13, 5 and 18 at the Mariental nesting area on 10, 22 and 31 March and 2 April respectively. The method of construction is based on investigations of nests together with observations on nesting behaviour.

*Description:* The nest of *P. namibiensis* consists of a multicellular subterranean burrow (Figs. 19–23) surmounted by a curved, tubular mud-turret of the same diameter as the burrow opening and usually with its greater length parallel to the soil surface. The main shaft is vertical and is of equal diameter throughout its entire length. At its base it curves outwards to



Figs. 5–10. *Priscomasaris namibiensis* with nest entrance turret. 5 and 6, Preparing to enter nest entrance turret. 7, Entering nest entrance turret, ventral surface uppermost. 8, Preparing to leave nest to discard the mud-pellet held between mandibles. 9, Flying away from nest with a mud-pellet which will be dropped in the pellet-dropping area. 10, Adding mud to the rim of entrance turret. Actual length of wasp c 8 mm.



Figs. 11–16. Forage plants of *Priscomaris namibiensis*. 11, *Lincum sulcatum* (Molluginaceae), flowers white, *P. namibiensis* leaving after foraging on the flowers. 12, *Lincum argute-carinatum* (Molluginaceae), flowers white. 13, *Lincum myosotis* (Molluginaceae), flowers white. 14, *Trianthema parvifolia* (Aizoaceae: non-Mesembryanthema), flowers white or pink. 15, *Sesuvium sesuvioides* (Aizoaceae: non-Mesembryanthema), flowers purplish-pink. 16, *Gisekia africana* (Molluginaceae), flowers pink; entrance turret of *P. namibiensis* on left.

form a short lateral shaft which terminates in a sub-horizontal excavated cell in which is a constructed mud-cell. A second cell terminates a similar lateral shaft which leaves the vertical shaft at the same depth but at an acute angle from the first such that the two cells lie close together. Further cells in similar pairs are positioned almost immediately below the first pair, each pair deeper than that preceding it, so that the cells form a "stack" to one side of the main shaft. The largest number of cells found was 13.

**Method of construction:** When excavating a burrow, *P. namibiensis*, using its mandibles, extracts soil as moist mud-pellets. As nest constructing females make frequent visits to water it is almost certain that regurgitated water is used for moistening the soil.

At an early stage in shaft excavation the entrance turret is constructed from pellets extracted from the burrow. These are laid down around the rim of the entrance to the burrow in such a way that its inner diameter equals that of the main shaft (i.e. 3 mm). At the outset of turret construction the thickness of the wall is c 1 mm but after the turret has reached a height of a few millimetres is reduced to 0.5 mm. After the turret reaches a height of c 6 mm, pellets are usually added in such a way that the turret curves over, typically until the opening is vertical, after which they are added evenly around the circumference of the turret and the resultant horizontal tube is extended parallel with the soil surface for a further 13–17 mm, separated from it by a c 2 mm gap.

A female, when entering a nest, alights on the upper surface of the turret facing towards the opening (Fig. 5) and then curves over its lip (Fig. 6), entering and progressing along the passageway ventral surface uppermost (Fig. 7). When leaving the nest during shaft excavation she reverses the procedure emerging posterior end first, ventral surface uppermost and climbing out onto the upper surface (Fig.

8). Thus before flying away she is facing towards the turret opening. Whilst building the turret she remains curved around the rim (Fig. 10), rotating whilst placing mud with her mandibles and apparently supporting and tamping it with the tip of her abdomen.

When discarding a mud pellet, a female, holding the pellet in her mandibles, flies (Fig. 9) on a roughly circular path, dropping the pellets 10 to 30 cm from the nest. Usually the variation in distance of an individual's flight path is not more than 7 cm so that the pellets accumulate in a small area (Fig. 17).

The walls of the shaft are stabilized and smoothed with the addition of water. The diameter of the shaft (3 mm) is maintained constant throughout its length. There is no turning "bulb" such as that found in the nests of most species of *Ceranius* (S.K. Gess 1996). At a depth of 60–80 mm (average 69,  $n = 17$ ) the shaft curves and after c 5 mm is expanded in the excavation of a cell of length c 15 mm and diameter c 5 mm.

Within the excavated cell a mud-cell (Figs. 19–23) is constructed, fitting closely within it but easily removed from it. On the outer surface evidence of deposition of mud-pellets is visible and a faint "fish scale" pattern similar to the more marked pattern exhibited by constructed cells of *Celonites* (S.K. Gess 1996) and *Pseudomasaris* (Torchio 1970) is discernable (Fig. 21). The inner surface of the mud-cell is smoothed (Fig. 20). The closed inner end is rounded whereas the outside tip of the mud-cell is consistently markedly papillate (Figs. 20–22). Apart from the tip, mud-cells are constant in diameter along their length, cigar-shaped, not ovoid.

The source of soil for the construction of the mud-cells was not determined. No quarry site within the nest was found. In nests with newly constructed open mud-cells there did not appear to be an excavated or partially excavated cell which could have been the source. As there is no



Fig. 17. Entrance turret of *Priscomasaris namibiensis* on right (arrow), discarded mud-pellets on left (arrow), amongst the branches of a species of *Indigofera* (Papilionaceae).

turning "bulb" such a source is also eliminated. The builders were carefully observed and were not bringing in soil from outside the nest. On numerous occasions, during nest investigation, loose dry soil was found in the main shaft from a depth of 50 mm downwards. It is highly unlikely that this soil had fallen into the shaft. It seems possible that, when a cell is excavated, extracted soil is not carried out as pellets but stored loose in the shaft and that the female coming and going from the nest can pass through the loose soil. This soil would then be available for mud-cell construction.

The constructed mud-cell walls appear to be harder and more brittle than those of the turret. This suggests that either, as in drying of concrete, slower drying of the mud used in mud-cell construction results in a "stronger" cementing or that something other than water is added to the

mud mixture. As *Celonites* and *Pseudomasaris* use nectar for bonding soil used in cell construction (S.K. Gess 1996 and Torchio 1970), nectar was considered a possibility. One gram of cell wall was tested for sugar content. Total sugars extracted amounted to only 3 milligrams, 0.6 micrograms of which were found to be glucose and 0.8 micrograms fructose. This appears to be too low a concentration of sugars to suggest deliberate use of nectar (Chris Whitely pers. com.) and therefore should be considered rather to be accidentally added from the crop which is used variously to carry nectar and water.

A mud-cell, in which oviposition and provisioning have been completed, is sealed with a mud-plug that fits into the neck of the cell, closing but not sealing it. After this plug has been constructed there is further addition of mud, extending across the plug and the rim of the mud-

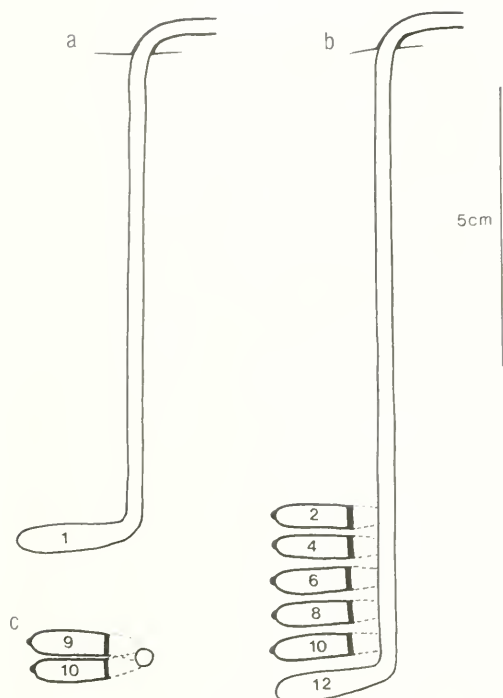

Fig. 18. Plans of two nests of *Priscomasaris namibensis*. a and b, vertical in single plane. a—nest with first cell only. b—nest with 12 cells. c, transverse in single plane.

cell, effectively sealing it. The remaining few millimetres of the lateral shaft are then filled with soil. Finally, where the shaft curves away from the vertical shaft, mud is used for sealing and plastering so that, when a nest with sealed cells is opened, there is no sign in the walls of the vertical shaft that any lateral shaft other than one leading to an open cell exists (Fig. 22).

A first cell having been completed and sealed off, a second lateral shaft leading to a second cell is excavated (and a mud cell constructed within it) at the same depth as the first and in the same plane, but at an acute angle from it.

On the completion and sealing off of the second cell a third lateral shaft with cell is excavated almost immediately below the first after a slight deepening of the vertical shaft. A fourth shaft and cell follows almost immediately below the second in the

same plane as the third. Excavation of further lateral shafts with cells follows this pattern so that a double "stack" of sub-horizontal cells (excavated cells each containing a constructed mud-cell) forms to one side of the vertical shaft.

Of the 22 nests investigated at Mariental on 10 March 5 (22.7%) had not yet reached the stage of lateral shaft excavation, 4 (18.2%) had reached lateral shaft excavation but not cell excavation, 6 (27.3%) had one cell each, and 5 (22.7%) had two cells. Twelve days later 12 nests were investigated, 4 (33.3%) had one cell each, 1 (8.3%) two cells, 2 (16.7%) three cells, 2 (16.7%) four cells, 1 (8.3%) 11 cells, and 1 (8.3%) 13 cells.

Taking two as possibly the largest number of cells per nest on 10 March and 13 twelve days later, it is estimated that it is possible that a cell could be prepared, oviposited into and provisioned in a single day. This is of course a very rough estimate but would be comparable with the rate observed for *Celonites latitarsis* Gess (Gess and Gess 1992) and *Masariina strucki* Gess (Gess, Gess and Gess 1997).

*Life history.*—From two nests each with a constructed mud-cell, empty except for an egg, it was possible to establish the positioning of and appearance of the egg. The eggs were white, slightly curved, more rounded at one end than at the other, 2.6 and 2.22 mm in length and 0.72 and 0.68 mm in diameter at mid-length. Each egg was positioned across the inner end of the mud-cell, cemented at its narrower end to the mud-cell wall.

A larva initially feeds only from one side of the mass of provision so that the "pollen loaf" extracted from a cell with a feeding early instar larva is not of even diameter along its length, but has an acentric process at the inner end, the length of the process in relation to the length of the provision being in proportion to the size of the larva.

The larva consumes the entire provision and then defecates at the inner end of the

mud-cell. The fecal mass forms a mustard coloured deposit on the inner surface of the mud-cell to a distance of 3–4 mm from the inner end. Microscopic examination revealed that it contains a mass of empty pollen grain walls, in no way macerated, with the pores widely extended. In addition approximately half-way along the length of the mud-cell an irregular mass of white crystalline matter is deposited. In several of the cells investigated fungal hyphae bearing penicillate sporangiophores and white spores covered the fecal mass.

The mud-cell walls from the edge of the fecal layer to approximately 10 mm from the inner end of the cell are lined by the larva with a parchment-like silken layer. At approximately 10 mm from the inner end of the cell it constructs a seal. Viewed from within the mud-cell the seal is in the shape of a round, flat-bottomed dish and viewed from the mud seal looking into the cell it has the appearance of a truncated cone. Both surfaces are brown and varnished in appearance. Between the inner and outer sloping walls is a series of silken parchment-like lamellae (Fig. 23). The central disc which forms the bottom of the inner "dish" and outer inverted "truncated cone" is thin and translucent. As the silken covering of the mud-cell walls only extends to the fecal mass there is not a complete cocoon.

On emerging the adult "cuts" out the flat, varnished "bottom" of the dish-like seal leaving a circular lamellate collar in place. The "varnished" disc is left pushed to one side.

*Voltinism.*—The findings suggest that there can be at least two generations of *P. namibiensis* per year. Clearly the nests investigated on 9 and 10 March were all recently started by recently emerged females. Those investigated on 22 March were a mixture of recently started nests and nests of which the initiation was probably contemporary with those investigated on 10 March. This suggested an initial staggered emergence of females. The nests

investigated on 31 March and 2 April, after a week of rains, were all recently started. These could have been initiated by a fresh flush of females of the same generation as the nest builders of 10 March or a second generation of adults.

That *P. namibiensis* is possibly bivoltine was demonstrated further, when, later in April, a male and two females emerged from three mud-cells collected on 22 March from nests of actively nesting females, there being no evidence of re-use of natal nests.

## DISCUSSION

Gess and Gess (1980 and 1992) and S.K. Gess (1996) discussed possible evolutionary sequences in the Masarinae. They suggested a sequence from the excavation of burrows with excavated cells only (as practised by *Ceramius damarinus* of species Group 4, *Ceramius* species of Group 8 and *Trimeria howardi*) through excavated burrows with constructed earthen-cells within excavated cells with earth for construction being derived from within the burrow (as practised by *Ceramius* species of groups 2, 3, 5, 6, and 7, at least three species of *Paragia* and at least two species of *Jugurtia*) to the presumably more advanced construction of aerial earthen-cells (as typically practised by *Celonites*, *Pseudomasaris* and *Gayella*).

That *P. namibiensis* constructs earthen-cells (mud-cells) within excavated cells suggests that this behaviour is plesiomorphic for Masarinae and that excavation of cells without constructing cells within them is, for Masarinae, derived.

Descriptions of nesting by *Euparagia scutellaris* Cresson (Williams 1927, Clement and Grissell 1968 and Trostle and Torchio 1986) do not suggest that *Euparagia* (Euparagiinae, formerly included in Masariidae) constructs earthen-cells within excavated cells. Similarly, there appears to be no evidence for construction of cells in self-excavated cells by any Eumeninae. It would seem that construction of earthen-



19

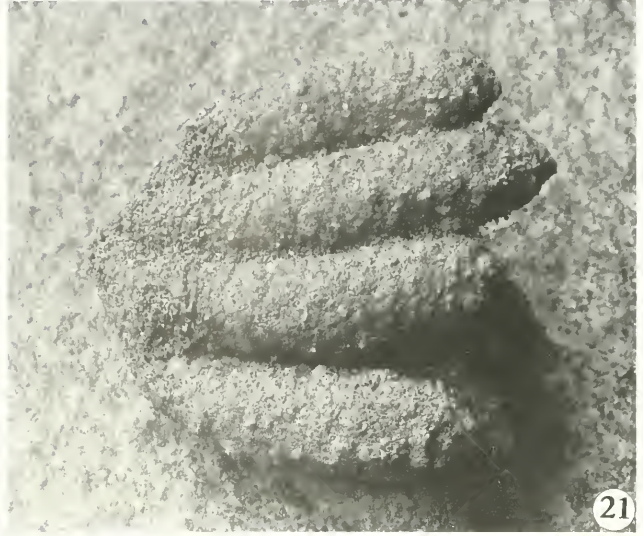

21



22



20



23

Figs. 19–23. Nest burrow and constructed mud-cells of *Priscomasaris namibiensis*. 19, Burrow cut in vertical plane. 20, Constructed mud-cells, four viewed end on (note papillate inner end of mud-cells) and one cut transversely to show thickness of cell wall and smoothed inner surface. 21, Group of constructed mud-cells with second cell from top showing “fish-scale” pattern. 22, Group of constructed mud-cells sealed off from cut main shaft which is shown cut vertically. 23, Constructed mud-cell cut longitudinally, showing tully grown larva and silken parchment-like closure.

cells within self-excavated cells is, in the Vespidae, probably restricted to Masarinae. Indeed, construction of cells within self-excavated cells by aculeate wasps appears to be restricted to Masarinae and certain Apoidea, the two groups of aculeates that provision with pollen and nectar.

The egg of *E. scutellaris* is, like that of Eumenidae, attached to the cell wall by a thread (Trostle and Torchio 1986) suggesting that attachment of the egg by a thread is plesiomorphic for Vespidae. It is therefore of note that the egg of *P. namibiensis*, like that of all other Masarinae, for which the egg is known, is not attached by a thread.

S.K. Gess (1996) stated that as a general rule at temperate latitudes pollen wasps appear to be univoltine but that Zucchi *et al.* (1976) suggested that *T. howardi* in subtropical South America may be bivoltine. It is therefore of particular interest that it has now been demonstrated that *P. namibiensis* is bivoltine. This suggests that the recorded second flush of nesting by *Jugurtia confusa* Richards (Gess and Gess 1980) after late summer rain in the Eastern Cape of South Africa may indicate that under optimal summer conditions *Jugurtia* may also be bivoltine. It is therefore possible that whether or not pollen wasps in southern Africa are uni- or bi-voltine varies from year to year with varying spring and summer rainfall patterns.

#### ACKNOWLEDGMENTS

Thanks are expressed to the following for much appreciated assistance: Estelle Brink of the Schonland Herbarium, Albany Museum, Grahamstown, and Coleen Mannheimer and Sabine Austaller, both of the National Botanical Research Institute, National Herbarium of Namibia, Windhoek, for assistance with the identification of the plant specimens; Fred Gess of the Albany Museum, Grahamstown, my co-researcher in the study of aculeate wasps and bees of the semi-arid areas of southern Africa, for identification of flower visitors, for taking the photographs reproduced as Figs. 3 and 4), and for valuable discussion and encouragement; Chris Whiteley of the Department of Biochemistry and Microbiology, Rhodes

University, Grahamstown for undertaking the sugar analysis on the walls of constructed mud-cells of *P. namibiensis*; Eric Grissell and Philip Torchio for their constructive reviewing of an earlier version of the manuscript; the Namibian Ministry of Environment and Tourism for granting a permit to conduct research and collect biological specimens in Namibia; and the South African National Research Foundation (formerly Foundation for Research Development) for running expenses grants for fieldwork during the course of which the present study was undertaken.

#### LITERATURE CITED

- Clement, S. L. and E. E. Grissell. 1968. Observations of the nesting habits of *Euparagia scutellaris* Cresson (Hymenoptera: Masaridae). *Pan-Pacific Entomologist* 44: 34-37.
- Gess, F. W. 1998. *Priscomasaris namibiensis* Gess, a new genus and species of Masarinae (Hymenoptera: Vespidae) from Namibia, southern Africa, with a discussion of its position within the subfamily. *Journal of Hymenoptera Research* 7: 296-304.
- Gess, F. W. and S. K. Gess. 1990. Ethological studies of *Jugurtia confusa* Richards, *Ceranius capicola* Brauns, *C. linearis* Klug and *C. lichtensteini* (Klug) (Hymenoptera: Masaridae) in the eastern Cape Province of South Africa. *Annals of the Cape Provincial Museums (Natural History)* 13: 63-83.
- Gess, F. W. and S. K. Gess 1992. Ethology of three southern African ground nesting Masarinae, two *Celonites* species and a silk spinning *Quartinia* species, with a discussion of nesting by the subfamily as a whole (Hymenoptera: Vespidae). *Journal of Hymenoptera Research* 1: 145-155.
- Gess, S. K. 1996. *The Pollen Wasps: ecology and natural history of the Masarinae*. Cambridge, Mass.: Harvard University Press. 340 pp.
- Gess, S. K. 1999. Distribution and ethology of *Ceranius damarinus* Turner (Hymenoptera: Masarinae) in Namibia. In: Byers, G. W., Hagen, R. H. and Brooks, R. W. (eds.), *Entomological Contributions in Memory of Byron A. Alexander. University of Kansas Natural History Museum Special Publication* 24: 25-32.
- Gess, S. K., F. W. Gess and R. W. Gess. 1997. Update on the flower associations of southern African Masarinae with notes on the nesting of *Masarina stucki* Gess and *Celonites garipeensis* Gess (Hymenoptera: Vespidae: Masarinae) in southern Africa. *Journal of Hymenoptera Research* 6: 75-91.
- Giess, W. 1971. A preliminary vegetation map of South West Africa. *Dinteria* 4: 1-114.
- Lovegrove, B. 1993. *The Living Deserts of Southern Africa*. Cape Town: Fernwood Press. 224 pp.
- Rutherford, M. C. and R. H. Westfall. 1986. Biomes of Southern Africa—an objective categorization. *Memoirs of the Botanical Survey of South Africa* 54: 1-98.

- Torchio, P. F. 1970. The ethology of the wasp, *Pseudomasaris edwardsii* (Cresson), and a description of its immature forms (Hymenoptera: Vespoidea, Masaridae). *Contributions in Science* 202: 1–32.
- Trostle, G. E. and P. F. Torchio. 1986. Notes on the nesting biology and immature development of *Euparagia scutellaris* Cresson (Hymenoptera: Masaridae). *Journal of the Kansas Entomological Society* 59: 641–647.
- Williams, F. X. 1927. *Euparagia scutellaris* Cresson, a masarid wasp that stores its cells with the young of a curculionid beetle. *Pan-Pacific Entomologist* 4: 38–39.
- Zucchi, R., S. Yamane and S. F. Sakagami. 1976. Preliminary notes on the habits of *Trimeria howardi*, a Neotropical communal masarid wasp, with description of the mature larva (Hymenoptera: Vespoidea). *Insecta matsumarana*, new Ser., 8: 47–57.
- APPENDIX 1
- Collection records of *Priscomasaris namibiensis* Gess listed under the vegetation types of Giess (1971) (given by number and name, see also Fig. 1) and the biomes of Rutherford and Westfall (1986) as adapted by Lovegrove (1993) (see Fig. 2).
- 5—Mopane Savanna (falling within the Nama Karoo Biome)
- 20 13 BB [20.15–20.30S 13.45–14.00E], Wêreldsend (M. Penrith, v.1982) (pers. com. J. Carpenter, 29.x.1999)
- 20.17S 14.05E, between Palm and Khorixas (F. W. and S. K. Gess, 31.iii.1997)
- 20.26S 14.54E, 15.5 km by road west of Khorixas (F. W. and S. K. Gess, 31.iii.1997)
- 20.31S 14.56E, 23 km by road from Khorixas to Uis (F. W. and S. K. Gess, 1.iv.1997)
- 9—Dwarf Shrub Savanna (falling within the Nama Karoo Biome)
- 24.11S 16.56E, southeast of Bullsport (F. W. and S. K. Gess, 11.iii.2000)
- 24.40S 17.57E, 5 km south of Mariental by road to Keetmanshoop (F. W. and S. K. Gess, 10 and 31.iii.2000 and 2.iv.2000)
- 24.58S 17.55E, 43 km south of Mariental by road to Keetmanshoop (F. W. and S. K. Gess, 4.iv.1997)
- 25.17S 17.50E, 7 km south of Gibeon railway siding by the Mariental/ Keetmanshoop road (F. W. and S. K. Gess, 9.iii. and 3.iv.2000)
- 25.24S 17.54E, 97 km south of Mariental by road to Keetmanshoop (F. W. and S. K. Gess, 4.iv.1997)
- 25.53S 18.07E, Tses, 161 km south of Mariental by road to Keetmanshoop (F. W. and S. K. Gess, 4.iv.1997 and 17.iv.1998)

## The Australian Species of *Pachyneuron* Walker (Hymenoptera: Chalcidoidea: Pteromalidae)

GARY. A. P. GIBSON

Systematic Entomology Section, Eastern Cereal and Oilseed Research Centre, Agriculture and Agri-Food Canada, Ottawa, Ontario, Canada K1A 0C6 (E-mail: gibsong@em.agr.ca)

---

*Abstract.*—Four species of *Pachyneuron* Walker are recognized from Australia: *P. aphidis* (Bouché 1834), *P. emersoni* Girault (1916), *P. nelsoni* Girault (1928) and *P. rieki* Gibson, n. sp. A lectotype is designated for *P. emersoni*. *Pachyneuron kingsleyi* Girault (1916) is formally synonymized with *P. emersoni* (new synonymy). Males and females of the four species are differentiated by key features, illustrated, and compared with morphologically similar species present in other regions. *Pachyneuron emersoni* and *P. rieki* are restricted to Australia, *P. aphidis* and *P. nelsoni* are more widely distributed. World distribution is summarized for *P. aphidis* and *P. nelsoni* and Australian distribution and host records are compiled for all the species.

---

*Pachyneuron* Walker consists of about 50 recognized world species with the following distribution as listed by Noyes (1998): Afrotropical (4), Australasian (5), Oriental (8), Neotropical (11), Nearctic (12) and Palearctic (28). Szelenyi (1942) gave a key to the Palearctic species, Graham (1969) to the European species and Kamijo and Takada (1973) to the Japanese species, but in other areas the species are unrevised and some distributional records listed in Noyes (1998) are questionable. Most species are hyperparasites of Aphididae or of other plant sucking Hemiptera (Coccoidea, Psylloidea) through their Braconidae (Ichneumonoidea) or Aphelinidae and Encyrtidae (Chalcidoidea) primary parasitoids, or are primary parasitoids or hyperparasitoids of the predators of these plant pests (Diptera: Syrphidae, Chamaemyiidae; Coleoptera: Coccinellidae; Neuroptera: Chrysopidae). Some species are also recorded as pupal parasitoids of mining or gall forming Diptera (Agromyzidae, Chloropidae, Cecidomyiidae) or as egg parasitoids of several families of Lepidoptera (apparently as hyperparasitoids), and there are rare records from other families

of Diptera, Hymenoptera and Coleoptera (Noyes 1998).

Bouček (1988) listed four species of *Pachyneuron* from Australia, but suggested that *P. kingsleyi* Girault was probably only a form of *P. emersoni* Girault and estimated that there were probably five valid species. Based on the very few localities listed by Bouček (1988) for the species and the absence of other than the original publications of Girault on Australian *Pachyneuron*, the genus might be thought to be relatively rare and unimportant. However, three of the four recognized species are common and two are widely distributed throughout Australia (Figs. 49–51). I examined over 2,000 specimens for this study and the species undoubtedly are major factors in the population dynamics of Australian aphids and their syrphid predators. The purpose of this study is to differentiate the Australian species and to tabulate the known hosts and distribution of the species in Australia.

### MATERIALS AND METHODS

Literature citations for W.H. Ashmead and A.A. Girault incorporate the paper numbers, between brackets following the

year of publication, that are used in their bibliographies by Crawford (1908) and Dahms (1978), respectively. Morphological terms and abbreviations used for structures mostly follow Gibson (1997). Newly used abbreviations and terms are: 'mvw' for 'marginal vein width', the maximum width of the marginal vein, and petiole 'body' (Fig. 22) for the more or less rectangular portion posterior to the constricted or tapered petiole 'neck' (Fig. 22) that articulates with the propodeal foramen. Measurements were made from dry-mounted specimens using an ocular micrometer with 100 divisions per centimetre and a binocular microscope with zoom magnification up to 225 $\times$ . Specimens for scanning electron microscopy (SEM) were prepared following Bolte (1996); illustrations of *P. aphidis* were made from specimens from North America. The SEM micrograph negatives were converted into a digital format using a 35mm scanner. Photographs of forewings mounted in Canada Balsam on slides were taken using a digital camera mounted on a dissecting microscope. These digital images were enhanced using Adobe Photoshop<sup>TM</sup>, and assembled into final plates using CorelDraw<sup>TM</sup>. Distribution maps were generated using Bio-link<sup>©</sup>. Only those localities whose position could be determined unequivocally were mapped so that the maps generally are less comprehensive than the listed records. Length of the sections summarizing material examined under 'Distribution' for each species was reduced using the following procedures: all specimens validating locality records are in ANIC unless otherwise indicated; locality records are listed in alphabetical order with different localities separated by a period, records with the same primary locality are separated by semicolons and the primary locality is omitted from the second and subsequent records; the sex and number of specimens examined are not given for the three common species; all collection dates have been standardized, including omit-

ting the first two numerals of the year; and the four most frequent collectors, C.J. Burwell, J.C. Cardale, I.D. Naumann and J.S. Noyes are shortened to CJB, JCC, IDN and JSN, respectively. The study was based on specimens provided by the individuals and collections listed below; acronyms are used in the text to denote depositories of specimens; those collections denoted with an asterisk provided type material or other specimens of Nearctic and Palearctic species that were used to help establish correct nomenclature.

ANIC	Australian National Insect Collection, CSIRO, Canberra, ACT (J. Cardale and S. Schmidt)
ASCU	Agricultural Scientific Collections Unit, Orange Agricultural Institute, Orange, NSW (M. Fletcher and P. Gillespie)
BMNH*	The Natural History Museum, London, England (J. Noyes)
CNCI*	Canadian National Collection of Insects, Ottawa, ON, Canada
DPIQ	Queensland Department of Primary Industries, Brisbane, QLD (J. Donaldson)
HFES*	Hokkaido Forest Experiment Station, Bibai, Hokkaido, Japan (K. Kamijo)
MHNG*	Muséum d'Histoire naturelle, Geneva, Switzerland (B. Merz)
QMBA	Queensland Museum, Brisbane, QLD (C. Burwell)
UQIC	University of Queensland Insect Collection, St. Lucia, QLD (G. Daniels)
USNM*	United States National Entomological Collection, U.S. National Museum of Natural History, Washington, DC (E. Grisell)
WARI	Waite Agricultural Research Institute, University of Adelaide, Glen Osmond, SA (A. Austin)

#### *Pachyneuron* Walker

*Pachyneuron* Walker, 1833: 371, 380. Type species: *Pachyneuron formosum* Walker, by monotypy.

*Pachyneuron* Blanchard, 1840: 260, 266. Unjustified emendation.

*Pachyneurum* Agassiz, 1846: 778. Unjustified emendation.

*Serimus* Brèthes, 1913: 90. Type species: *Serimus argentinus* Brèthes, by monotypy. Synonymy by De Santis, 1957: 118.

*Propachyneuronia* Girault, 1917[327]: 102. Type species: *Encyrtus siphonophorae* Ashmead, by original designation. Synonymy by Gahan, 1918: 66.

*Nepachyneuron* Girault, 1917[330]: 9. Type species: *Pachyneuron eros* Girault, by original designation. Synonymy by Timberlake, 1926: 308.

*Eupachyneuron* Blanchard in Leiboff, 1948: 256. Type species: *Eupachyneuron bosqui* Blanchard, by monotypy. Synonymy by Bouček, 1988: 441.

*Atrichoptilus* Delucchi, 1956: 141–142. Type species: *Pachyneuron aeneum* Masi, by original designation. Synonymy by Bouček, 1965: 18.

*Pachyneuron* (*Serimus*); De Santis, 1975: 8–10. Change of status.

**Diagnosis.**—Head without distinct malar depression; clypeus with apical margin shallowly emarginate (Figs. 17, 18) to produced (Figs. 1, 2); gena and lower face excluding clypeus mostly isodiametric-reticulate (Fig. 18); torulus at or above lower orbit near middle of face (Figs. 1, 13, 16, 17, 25, 30, 47). Mandible with four teeth (Figs. 1, 2). Antenna 13-segmented with 2 or 3 anelli; scape of female, when appressed to head, extending to anterior ocellus; scape of male subequal in width or evenly tapered to apex (Figs. 9, 21, 33, 34, 45, 46). Pronotum visible in dorsal view, with pronotal carina (in regional species) (Figs. 3, 4, 14, 26, 37, 38). Mesonotum reticulate, the sculpture formed by raised ridges; mesoscutum with incomplete notauli (Figs. 3, 4); mesopleuron with upper mesepimeron shiny and much more finely sculptured than lower mesepimeron (Figs. 4, 38). Propodeum with supracoxal flange shorter than length of nucha (Fig. 15). Metacoxa bare dorsobasally (Figs. 4, 38), outer surface smooth to coriaceous-reticulate, much more finely sculptured than reticulate femoral depression

(Figs. 4, 38). Forewing with marginal vein noticeably thicker than stigmal or post-marginal veins and at least slightly widened distally, about as long as stigmal vein and at most 0.35 length of costal cell (Figs. 6, 24, 36, 48). Gaster variably distinctly petiolate (Figs. 11, 22, 27, 41); first gastral sternum with anterior margin unmodified, not produced into flange beneath petiole (Figs. 12, 28, 42); terga flat to low convex in critical-point dried female, often flat or collapsed in air-dried female.

**Remarks.**—Australian *Pachyneuron* can be identified to genus using the key of Bouček (1988). Individuals are most likely to be confused with specimens of the monotypic genus *Inkaka* Girault (Bouček 1988, figs. 767–769), but specimens of *I. quadridentata* (Girault) differ conspicuously by lacking a carinately margined pronotal collar, the pronotum being almost vertical and not visible in dorsal view. Individuals of *Inkaka* also have an obvious malar depression, the antennal toruli slightly below the level of the lower orbits, and a more elongate-slender marginal vein that is at least 0.4 times as long as the costal cell; in females the scape does not extend to the anterior ocellus, and in males the scape has two distinct subapical lobes on its anterior outer margin so as to appear emarginate subapically.

*Coruna* Walker and *Euneura* Walker are not yet recorded from Australia, but comprise species that are hyperparasites of aphids and that are morphologically similar to species of *Pachyneuron*. It probably is only a matter of time before species of one or both genera are accidentally introduced into Australia. Individuals of *Coruna* have sulcate notauli that extend to the transscutal articulation and therefore are easily distinguished from *Pachyneuron*; more subtle features differentiate *Euneura* from *Pachyneuron*. In *Euneura* the lower face is more extensively longitudinally striate-reticulate (Bouček 1988) and the supracoxal flange is longer than in *Pachyneuron*.

ron (Kamijo and Takada 1973). Also, in *Euneura* the metacoxa and femoral depression are similarly reticulate, whereas in *Pachyneuron* the metacoxa is much more finely sculptured than is the femoral depression.

Females of *Euneura* also have the metasoma strongly convex and hence more sub-circular in cross section than do females of *Pachyneuron*, but this difference is less obvious in critical-point dried individuals.

#### KEY TO AUSTRALIAN SPECIES OF *PACHYNEURON* WALKER

- 1 Both sexes: propodeum uniformly coriaceous anterior to nucha, without plical furrow or ridges (Fig. 5); petiole body in dorsal view shiny, virtually smooth and strongly transverse (Fig. 11); clypeus medially convex and apically rounded to angulate (Figs. 1, 2). *Female*: flagellum with 3 anelli and 5 funicular segments (Figs. 7, 8). *Male*: antenna brown except possibly for extreme base of scape and legs with femora mostly infusate . . . . . *P. aphidis* (Bouché)
- Both sexes: propodeum with variably distinct, more or less W-shaped complex of plicae and costulae anterior to nucha (Figs. 15, 29, 39); petiole body in dorsal view strongly reticulate to reticulate-rugose and often longer than wide (Figs. 22, 27, 41); clypeus medially flat to depressed and shallowly emarginate (Figs. 17, 18). *Female*: flagellum with 2 anelli and 6 funicular segments (Figs. 19, 20, 31, 32, 43, 44). *Male*: antenna with at least scape mostly or entirely yellow and legs yellow . . . . . 2
- 2(1) *Female*: flagellum clavate with longitudinal sensilla along almost entire length of flagellar segments and with adpressed setae (Figs. 19, 31, 43) . . . . . 3
- *Male*: flagellum filiform with longitudinal sensilla in apical half of flagellar segments and with semierect setae (Figs. 21, 33, 45) . . . . . 5
- 3(2) Forewing with basal cell separated from speculum by oblique line of at least 7 setae on dorsal surface of basal fold and with 2 or more setae within basal cell near apex (Fig. 48); petiole body with 1–3 setae projecting anterolaterally from each side near middle (Fig. 41) . . . . . *P. rieki* Gibson, new species
- Forewing usually completely bare basally, but at most with 1 or 2 setae on dorsal surface of basal fold (Figs. 23, 24, 35, 36); petiole body without setae projecting from lateral margin (Figs. 22, 27) . . . . . 4
- 4(3) Forewing without marginal fringe (Figs. 35, 36); marginal vein comparatively short and thick, length less than 2.5 times maximum width (Fig. 36), and postmarginal vein only slightly (less than 1.25 times) longer than stigmal vein (Fig. 36); propodeum reticulate-coriaceous anterior to nucha, similarly or even more strongly sculptured medially than laterally (Fig. 29) . . . . . *P. nelsoni* Girault
- Forewing with marginal fringe (Figs. 23, 24) and/or with relatively elongate-slender marginal vein at least 3.5 times as long as wide, and with postmarginal vein distinctly (at least 1.5 times) longer than stigmal vein (Fig. 24); propodeum with comparatively shiny, finely coriaceous to virtually smooth pentagonal or hexagonal region anterior to nucha (Fig. 15) . . . . . *P. emersoni* Girault
- 5(2) Forewing without marginal fringe (Figs. 35, 36); flagellar segments oblong, the middle segments less than 1.8 times as long as wide (Fig. 33); antenna uniformly yellowish or with flagellum light brown . . . . . *P. nelsoni* Girault
- Forewing with marginal fringe (Figs. 23, 24, 48); flagellar segments elongate, middle segments more than 1.8 times as long as wide (Figs. 21, 45); antenna usually with dark brown flagellum contrasting distinctly with yellow scape . . . . . 6
- 6(5) Forewing with basal cell separated from speculum by oblique line of at least 7 setae on dorsal surface of basal fold (Fig. 48); head with lower face uniformly convex (Fig. 47); scape in profile with line of distinct setae along anterior margin (Fig. 46) . . . . . *P. rieki* Gibson, new species

- Forewing with basal cell and speculum uniformly bare (Figs. 23, 24) and/or head with lower face distinctly depressed or concave lateral to convex supraclypeal area and clypeus (Fig. 16); scape in profile without line of distinct setae along anterior margin (Fig. 21b) ..... *P. emersoni* Girault

***Pachyneuron aphidis* (Bouché)**  
(Figs. 1–12, 49)

- Diplolepis Aphidis* Bouché, 1834: 170. Syntypes; types lost according to Graham, 1969: 842. Sex described: both.
- Pteromalus minutissimus* Förster, 1841: 28. Lectotype male, designated by Delucchi, 1955: 138. Type data: Germany, bred on *Aphidius rosarum*. Type depository: Naturhistorisches Museum, Vienna. Sex described: male. Synonymy by Reinhard, 1859: 195.
- Pachyneuron pruni* Walker, 1850: 128. Lectotype female, designated by Graham, 1969: 842. Type data: Prussia. Type depository: BMNH. Sex described: female. Synonymy by Graham, 1969: 842.
- Pachyneuron aphidis*; Reinhard, 1859: 195. Change of combination.
- Encyrtus siphonophorae* Ashmead, 1886[36]: 131. Syntypes, female (examined). Type data: USA, Florida [Jacksonville] bred in 1881 from orange aphid (*Siphonophora citrifolii* Ashmead). Type depository: USNM, type no. 4860. Sex described: female. Synonymy by Bouček, 1988: 441, 442.
- Pachyneuron aphidivora* Ashmead, 1887[37]: 14. Syntypes, both sexes (examined). Type data: USA, Florida [Jacksonville], bred June 6 from the cabbage aphid (*Aphis brassicae* L.). Type depository: USNM, type no. 2854. Sex described: female. Synonymy with *E. siphonophorae* by Girault, 1917[327]: 102. **Note:** According to Timberlake (1918: 402) Girault's synonymy is incorrect because notes of A.B. Gahan on the types, "taken when they were in a better state of preservation than at present, show that *aphidivorum* has only two ring-joints". However, although Ashmead described only females, both females and males are labelled as syntypes in the USNM collection and Gahan's note undoubtedly referred to a male.
- Pachyneuron maidaphis* Ashmead, 1888: 23. Syntypes, female (examined). Type data: USA, Florida [Lake City]. Type depository: USNM, type no. 26530. Sex described: female. Synonymy with *E. siphonophorae* by Girault, 1917[327]: 102.
- Pachyneuron micans* Howard, 1890: 246. Syntypes, female (examined). Type data: USA, Indiana, Lafayette, reared by Webster from *Siphonophora avenae*. Type depository: USNM, type no. 1467. Sex described: both. Synonymy with *E. siphonophorae* by Girault, 1917[327]: 102.
- Pachyneuron gifuensis* Ashmead, 1904[243]: 158. Syntypes, female (examined). Type data: [Japan], Gifu, bred by Y. Nawa [Oct. 1902] from an *Aphis*. Type depository: USNM, type no. 7190. Sex described: female. Synonymy by Kamijo & Takada, 1973: 57.
- Scrimus argentinus* Brèthes, 1913: 91. Holotype male. Type data: Argentina: Buenos Aires. Sex described: male. Synonymy by De Santis, 1957: 119.
- Pachyneuron lali* Mani, 1939: 81. Holotype female, by original designation. Type data: India: Karnal (Punjab), 15.iii.1938, K. B. Lal, bred from *Aphis rumicis* L. on *Solanum nigrum*. Type depository: Indian Agricultural Research Institute, New Delhi. Sex described: female. Synonymy by Bouček *et al.*, 1978: 451. **Note:** purported description of male applies to female based on description of three anelli, see Bouček *et al.* (1978).
- Pachyneuron ferrierei* Mani, 1939: 83. Syntypes, male. Type data: India: Chaubatia, U.P., R.N.I., 22.viii.1935, parasitic on an aphid causing leaf curl. Type depository: Indian Agricultural Research Institute, New Delhi. Sex described: male. Synonymy by Bouček *et al.*, 1978: 45. **Note:** type series mistakenly stated as female (Bouček *et al.* 1978).
- Eupachyneuron bosqui* Blanchard in Leiboff, 1948: 256. Type status unknown. Type data: Argentina, La Pampa, reared from *Schyzaphis graminum*. Sex described: female. Synonymy with *P. aphidis* by Bouček, 1988: 442.
- Pachyneuron minutissimum*; Delucchi, 1956: 129, 137–139. Change of combination.
- Pachyneuron triarticulata* Mani & Saraswat, 1974: 98–100. Holotype female, by original designation.

nation. Type data: India: Northwest Himalaya, Dalhousie (Ahla catchment area, Khajjiar), M.S. Mani and party, 18 & 27.v.1971. Type depository: USNM, database no. 0700023. Sex described: female. Synonymy by Bouček *et al.*, 1978: 451.

*Pachyneuron (Serinus) siphonophorae*; De Santis, 1975: 9. Change of status.

*Pachyneuron aphidis*; Bouček, 1988: 442.

*Female*.—Body brown to dark brown with variably distinct metallic green luster; antenna brown except extreme base of scape often yellowish; tegula yellow to brown; legs with femora variably darkly infuscate except apically yellowish, tibiae and tarsi yellowish or with tibiae lightly infuscate subbasally. Head with clypeus convex and apically rounded to angulate (Figs. 1, 2). Flagellum with 3 anelli (Fig. 8) and 5 funicular segments (Fig. 7); funicular segments subquadrate to oblong and with long, conspicuous, decumbent setae (Figs. 7, 8); longitudinal sensilla extending almost entire length of funicular segments, separated from each other by distance equal to 2–3 sensillar diameters (Fig. 8). Forewing (Fig. 6) with marginal fringe; with distinct discal setae; dorsally with basal cell apically delineated by oblique line of setae directed posterobasally from base of parastigma; ventrally with posterior margin of basal cell often delineated by longitudinal cubital setal line, and often with one to several setae on ventral surface near submarginal vein; speculum on dorsal surface open posteriorly; costal cell with distinct setae on ventral surface; veins with following ratios ( $n = 10$ ):  $smv/mv = 2.70\text{--}3.28$ ,  $mv/mvw = 2.75\text{--}3.58$ ,  $pmv/mv = 1.57\text{--}2.12$ ,  $pmv/st = 1.64\text{--}2.21$ . Mesonotum with highly convex, relatively slender scutellum (Figs. 3, 4). Propodeum (Figs. 3–5) strongly transverse, uniformly striate-coriaceous without median carina, costula, or plical carina except near nucha, but with paramedial transverse depressions basally; spiracle circular to slightly oval. Petiole without setae projecting from sides; in dorsal view body

strongly transverse, shiny and virtually smooth (Fig. 11); in ventral view divided mediolongitudinally by white membranous region (Fig. 12).

*Male*.—Similar to female except flagellum (Figs. 9, 10) with 2 anelli and 6 funicular segments; all segments, except possibly preclaval segment, longer than wide (at most about 1.8 times).

*Distribution*.—*Pachyneuron aphidis* is a cosmopolitan species that Noyes (1988) recorded from over 40 countries and all continents except Antarctica.

Australian distribution (Fig. 49) and host records based on label data of examined specimens are: **Australian Capital Territory**: Canberra, 2.xii.46, 18.vi.54, E.F. Riek; coll. 17.v.89, em. 25.v.89, *Diaeretiella rapae* ex. *Brevicoryne brassicae* on *Sisymbrium officinale*, V.F. Eastop; coll. 10.iii.89, em. 18.iii.89, *Aphidius souchi* Marshall ex. *Hyperomyzus lactucae* (L.) on *Sonchus oleraceus*, V.F. Eastop. **New South Wales**: Glossodia, 20.vi.80, parasite of *Aphis nerii*, D. James. Katoomba, 2.xii.75, IDN (UQIC). Merungle Hill, 2.ii.66, on mature oranges, M.I. Nikitin (ASCU). Mootwingee Nat. Pk., Old Mootwingee Gorge, 5–8.xi.84, G.R. Brown & H.M. Holmes (ASCU). Newport, 18.iii.36, ex. *Aphis nerii* (ASCU). Rob Roy, 29.v.74, ex. ear of wheat, M. Greening (ASCU). Rydalmere, 7.vi.61, L.T. Woolcock; 22.ii.68, parasitized *Brevicoryne brassicae*, J.T. Hamilton (ASCU). Sydney, 20.v.49, ex. pumpkin aphids (ASCU). Tamworth, 1.xi.79, ex. *Trioxys complanatus* on spotted alfalfa aphid, N. Forrester. Ulladulla, 18.i.72, ex. aphid on *Cakile edentula*, M. Gray; 10.ii.81, *H. lactucae*; 17.ii.81. Warrumbungles Nat. Pk. via Coonabarabran, 17.xii.74, IDN (UQIC). Wellington, 23.ii.54, ex. *B. brassicae*. **Queensland**: Beerwah, 3.5 km NW (26.50S 152.56E), CJB (UQIC). Brisbane, Alan Fletcher lab., ix.82, ex. galls on *Rhopalomyia californica* Felt, P. McFadyen (QDPI). Bunya Mts. Nat. Pk. nr. Westcott Plain (26.52S 151.34E), 6–7.x.84, IDN & JCC. Camp Mt., 1.x.61, ex. *Aphis nerii* on *Asclepias curassivica*, E.N. Marks (UQIC). Cecil Plains, D-Vac SIR-ATAC trial in cotton, 1981–82, P.D. Rossiter (QDPI). Gatton, 16.v.78, ex. *Microphyas divulsana*, B. Franzmann (QDPI); 5.v.81 (QDPI); D.P.I. Research Station, 1–7.ix.81, 7–14.ix.81, 21–28.ix.81 (QDPI). Helidon, 30.viii.79, ex. *Aphidius colemani* on *Aphis nerii*, B.A. Franzmann (QDPI). Lake Broadwater, 25 km SE Dalby (27.22S 151.06E), 2–3.iv.96, CJB (QMBA). Miles, 1 km W, Dogwood Ck., 7.x.74, I.D. Galloway (QMBA). Mt. Glorious (27.20S 152.46E), 27.ix.95, S.G. Evans (QMBA). Russell Pk. nr. Mt. Mowbullin (26.53S 151.37E), 7.x.84, IDN & JCC. Sanford, x.61, E. Warwick. Tenthill, 15.viii.79, ex. *Aphidius colemani* in

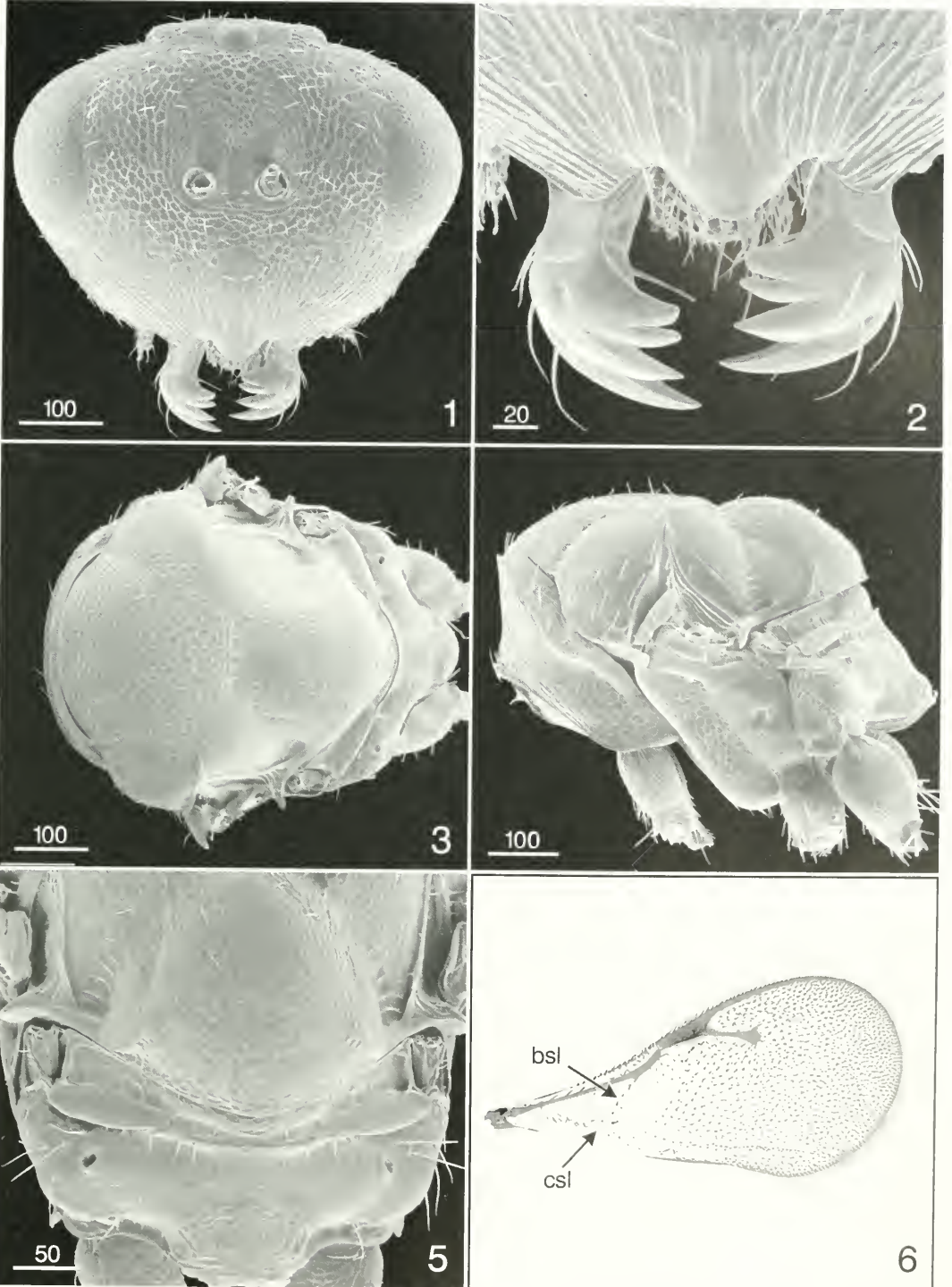

Figs. 1-6. *Pachyneuron aphidis*: 1, head, frontal (♀); 2, clypeus and mandibles (♀); 3, mesosoma, dorsal (♀); 4, mesosoma, lateral (♀); 5, scutellum-propodeum (♂); 6, forewing (♀). Scale bars =  $\mu\text{m}$ . Abbreviations: bsl = basal setal line, csl = costal setal line.

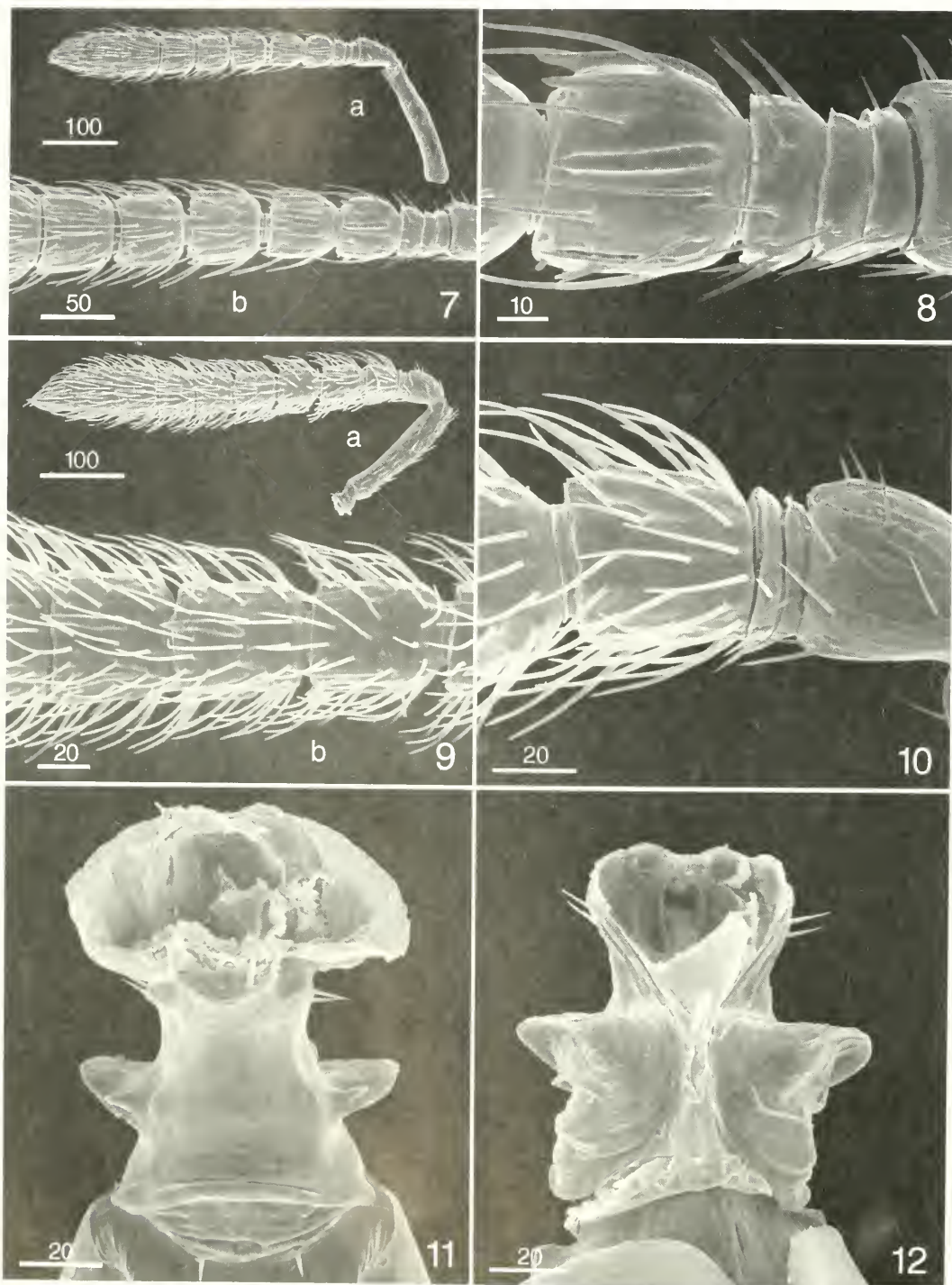

Figs. 7-12. *Pachyneuron aphidis*: 7, antenna (♀); 7a, entire, 7b, anelli and funicular segments; 8, basal flagellar segments, fl<sub>1</sub>-fl<sub>1</sub> (♀); 9, antenna (♂); 9a, entire, 9b, middle funicular segments, fl<sub>1</sub>-fl<sub>1</sub>; 10, basal flagellar segments, fl<sub>1</sub>-fl<sub>1</sub> (♂); 11, petiole, dorsal (♀); 12, petiole, ventral (♀). Scale bars = μm.

*Aphis nerii*, B.A. Franzmann (QDPI). Toowoomba, 16.v.75, ex. mummies on *Rhopalosiphum maidis*, H. Bri-er (QDPI); 15.x.79, ex. *Aphidius colemani* on *Aphis nerii*, B.A. Franzmann (QDPI). **South Australia:** Adelaide, Waite Institute, iv.88, hyperparasite of *Aphidius sonchi*, D. Martin (WARI). "Brecon", 10 km S Keith, 26.i.82, A.D. Austin (QDPI). Glen Osmond, Waite Ag. Res. Inst., coll. 24.iii.82, em. 30.iii.82, ex. pea aphid, D. Samoedl; W.A.R.L., 21.i.81, ex. *Trioxys*, SAA culture on lucerne, D. Samoedl; Waite Institute, vi.73, ex. *Brevicoryne brassicae* and *Myzus persicae*, C. Crawford. Pinnaroo, 25 km SSW (35.28S 140.47E), 20.x.89, 24.x.89, IDN & JCC; 49 km SW (35.42S 140.49E), 20.x.83, 24.x.83, IDN & JCC. **Victoria:** nr. Benalla, 9.ii.78, ex. *T. maculata*.

**Hosts.**—Noyes (1988) listed 115 species and 62 genera as hosts for *P. aphidis* in the following taxa: Diptera (Cecidomyiidae, Syrphidae), Hemiptera (Aphidoidea: Aphididae, Pemphigidae; Coccoidea: Coccidae, Kermesidae, Pseudococcidae; Psylloidea: Psyllidae), and Hymenoptera (Chalcidoidea: Aphelinidae, Encyrtidae; Ichneumonoidea: Braconidae). Based on label data, Australian primary and secondary hosts include Aphididae: *Acyrtosiphon pisum* (Harris), *Aphis nerii* (Fonscolombe), *Brevicoryne brassicae* (L.), *Nasonovia* (= *Hyperomyzus*) *lactucae* (L.), *Myzus persicae* (Sulzer), *Therioaphis maculata* (Buckton) and Braconidae: *Aphidius colemani* Viereck, *Aphidius sonchi* Marshall, *Diaeretiella rapae* (McIntosh), *Trioxys complanatus* (Pérez). There is also a single record from *Merophyas divulsana* (Walker) (Lepidoptera: Tortricidae) and an anomalous record of 'galls' on *Rhopalomyia californica* Felt.

**Remarks.**—*Pachyneuron aphidis* is the only species of *Pachyneuron* in Australia with a convex, apically rounded or angulate clypeus (Fig. 2). It is further differentiated from *P. nelsoni* and *P. emersoni* females by the presence of a basal setal line on the forewing (Fig. 6); however, specimens of *P. rieki* (Fig. 48) and rare *P. emersoni* males also have a forewing basal setal line. Females of *P. aphidis* are also unique within the genus because they have 3 anelli and 5 funicular segments, and the flagellum differs from those of other Aus-

tralian species because it has conspicuous decumbent setae similar to males (Figs. 7, 8). Males are easily distinguished by their brown antennae, males of the other species have at least the scape yellow.

Because of a similar clypeus and propodeum, individuals of *P. aphidis* are morphologically most similar to *P. californicum* Girault (1917[322]), known only from America north of Mexico. However, in *P. californicum* the petiole is completely sclerotized ventrally (i.e., forming a complete tube, cf. Fig. 28) even though short as in *P. aphidis*, and the speculum is usually closed on the ventral surface by a line of setae along the cubital fold.

#### *Pachyneuron emersoni* Girault

(Figs. 13–24, 50)

*Pachyneuron emersoni* Girault, 1916[274]: 229–230. Lectotype female, complete (examined), here designated: "878 ", "Swan Riv, W. Austr.", "G. Compere Collector", "♀ Lectotype Bouček 1985". Type depository: USNM, type no. 19691. Paralectotypes, here designated: 1 point with mesosoma, same data as lectotype (USNM type no. 19691); 1 slide with parts of two male antennae under one cover slip and a crushed head, one female hind leg and two male hind legs under another cover slip (USNM type no. 19691); 1 point with mesosoma, same data as lectotype (QMBA type no. HY 3568); 1 point with pair of middle legs, same data as lectotype plus "from Icerya, California, Alex. Craw, import from Australia, G. Compere, July 1900" (QMBA type no. HY 3568). **Notes:** Although Bouček labelled the two USNM point-mounted specimens as lectotype and paralectotype he did not validate these designations through publication. Girault's original description stated that the USNM has "two females on tags plus the slide"; however the point-mounted USNM paralectotype is a male, based on leg structure and color. The male antennae on the slide may belong to this specimen but it is unknown to which specimen the other parts belong.

*Pachyneuron kingsleyi* Girault, 1916[274]: 230. Holotype female (examined). Type data: Australia: N.S.W., Brooklyn, 31 October 1914.

Type depository: QMBA, type no. HY 3569.

Sex described: female. **New synonymy.**

*Pachyneuron emersoni*; Dahms, 1983: 246; Bouček, 1988: 442.

*Pachyneuron kingsleyi*; Girault, 1927[416]: 335; Girault, 1929[431]: 319; Dahms, 1984: 738–739; Bouček, 1988: 442.

*Female*.—Body dark with variably distinct metallic green luster; antenna dark brown except with basal half to all of scape yellow; tegula yellow; legs with femora variably darkly infusate except apically yellowish, tibiae and tarsi yellowish. Head with clypeus flat to slightly depressed and apically shallowly emarginate (Fig. 13). Flagellum compact-clavate, with 2 anelli (Fig. 20) and 6 funicular segments (Fig. 19); funicular segments slightly longer than wide basally to quadrate or slightly transverse apically and with adpressed setae (Figs. 19, 20); longitudinal sensilla extending almost entire length of funicular segments, separated from each other by distance equal to 1–2 sensillar diameters (Fig. 20). Forewing (Figs. 23, 24) usually with marginal fringe; with distinct discal setae; dorsally without line of setae differentiating apex of basal cell from speculum (very rarely with 1 or 2 setae on basal fold); ventrally without line of setae along cubital fold; costal cell with distinct setae on ventral surface (Fig. 23b); veins with following ratios ( $n = 10$ ):  $smv/mv = 2.94\text{--}3.60$ ,  $mv/mvw = 3.63\text{--}4.86$ ,  $pmv/mv = 1.32\text{--}1.64$ ,  $pmv/stv = 1.55\text{--}1.80$ . Mesonotum with relatively low convex, broad scutellum (Fig. 14). Propodeum (Fig. 15) with posteriorly convergent, carinately margined plical ridges and usually less distinct, often irregularly  $\cap$ -shaped anteromedian carina or ridge (costula) near base, the ridges together differentiating a more or less W-shaped basal region with coriaceous sculptured anterolateral depressions from a mostly shiny and smooth to finely coriaceous pentagonal or hexagonal posteromedian region anterior to a coriaceous or medially smooth and shiny nucha, with the short region anterior to  $\cap$ -

shaped ridge crenulate and the surface lateral to plical ridges finely coriaceous; spiracle distinctly oval. Petiole without setae projecting from sides (Fig. 22); in dorsal view distinctly (at least 1.75 times) longer than wide, with body slightly to distinctly longer than wide and uniformly reticulate (Fig. 22); in ventral view completely sclerotized with median furrow, the body distinctly longer than wide, finely coriaceous-reticulate and shiny.

*Male*.—Similar to female except as follows: body brighter metallic green or bluish green; legs uniformly bright yellow beyond coxae except metafemur sometimes lightly infusate; head with lower face distinctly concave (Fig. 16) to very shallowly depressed (Figs. 17, 18) lateral to convex supraclypeal area and clypeus; scape entirely yellow or brownish apically, slightly expanded and flattened basally immediately above radicle, tapered apically and slightly curved, and in lateral view without distinct line of setae along anterior margin (Fig. 21b); flagellum usually dark brown, filiform; funicular segments elongate, middle segments more than 1.8 times as long as wide and all segments with very sparse longitudinal sensilla within apical half and with conspicuous, semi-erect setae about as long as width of segment (Figs. 21a, c); forewing always with marginal fringe; basal cell on dorsal surface sometimes delineated apically by line of up to 7 setae, with 1–3 setae sometimes also delineating extreme posteroapical angle of cell, and rarely with 1–3 setae within cell toward apex. Petiole usually without setae, rarely with single seta projecting anterolaterally from one side near middle.

*Distribution* (Fig. 50).—**Australian Capital Territory**: Bendora, 14.xii.60, D.H. Colless. Blundell's, 26.ix.30, 14.iv.31, L.F. Graham; 6.i.61, E.F. Riek. Brindabella Ra., Lees Spring (35.22S 148.49E), 24.xi.81, IDN; nr. Lees Spring, 24.xi.31, L.F. Graham; Mt. Gini, 24.xi.81, IDN. **Canberra**, 14.ii.39, from cabbage, T.G. Campbell; 3.xii.39; 29.ix.46, 2.x.46, 6.viii.47, 15.vii.48, 8.xi.48, E.F. Riek; 25.xi.65, O.W. Richards; 10.v.66, ex. *Aphis craccivora*, D. Morgan; 18.i.80, on *Eucalyptus* blossom, IDN; 20.i.80, on *Bacckia* blossom,

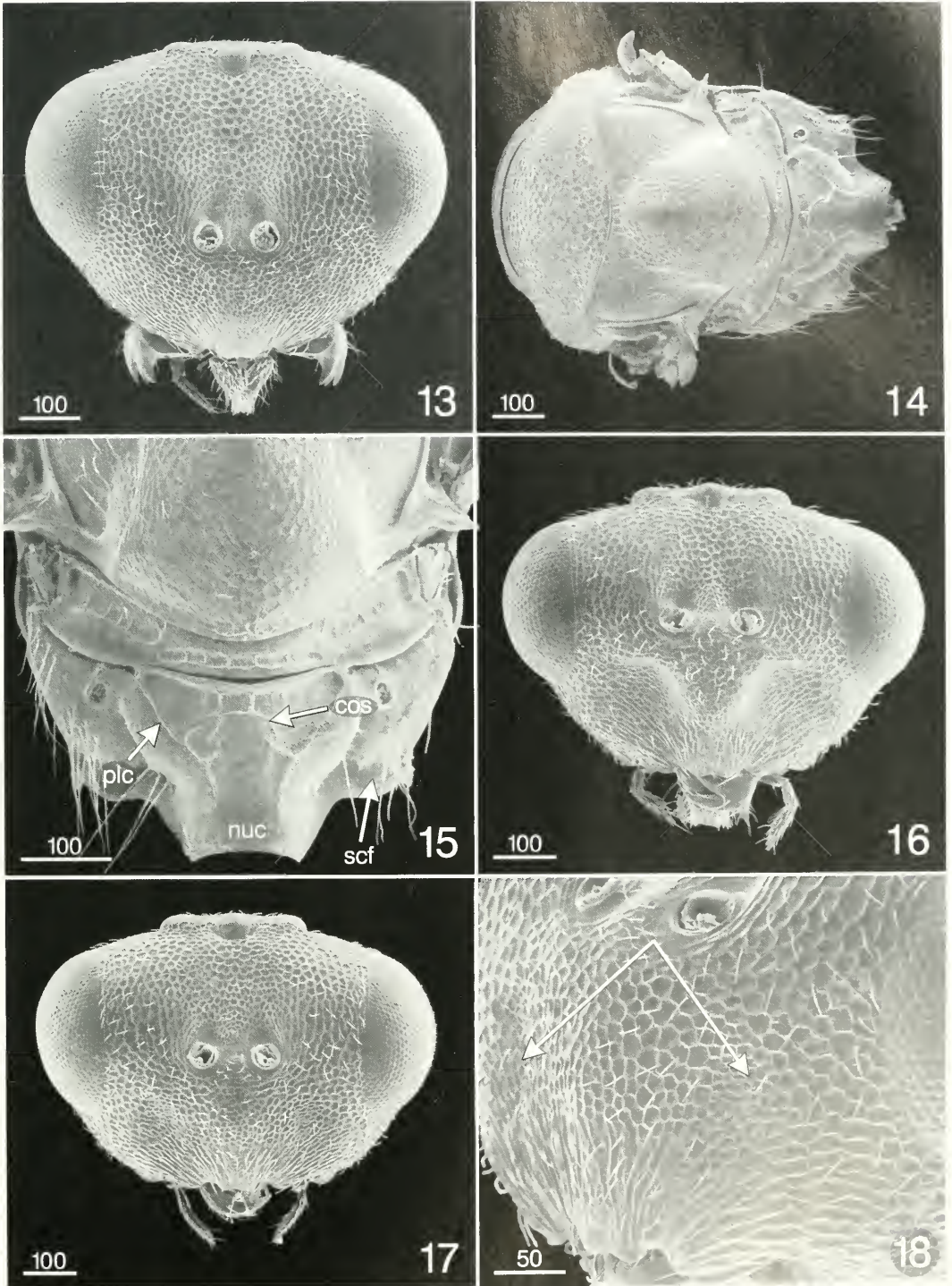

Figs. 13–18. *Pachyneuron emersoni*: 13, head, frontal (♀); 14, mesosoma, dorsal (♀); 15, scutellum-propodeum (♀); 16, head, frontal (♂); 17, head, frontal (♂); 18, lower face (♂) (arrows point to regions of finer sculpture within depressions). Scale bars =  $\mu\text{m}$ . Abbreviations: cos = costula, nuc = nucha, plc = plica, scf = supracoxal flange.

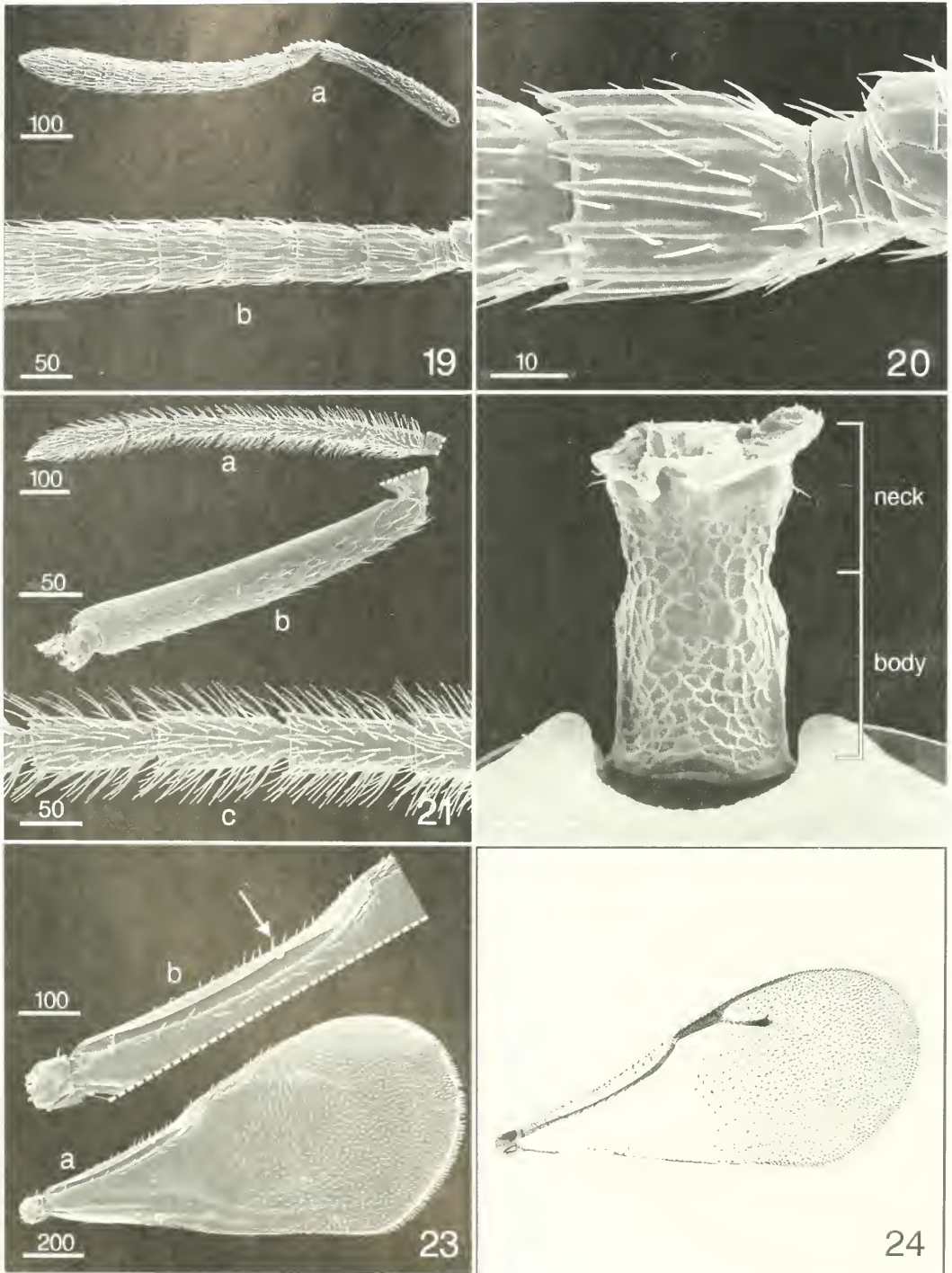

Figs. 19–24. *Pachyneuron emersoni*: 19, antenna (♀): 19a, entire, 19b, anelli and funicular segments; 20, basal flagellar segments, fl<sub>1</sub>-fl<sub>1</sub> (♀); 21, antenna (♂): 21a, entire, 21b, scape, 21c, middle funicular segments, fl<sub>1</sub>-fl<sub>1</sub>; 22, petiole, dorsal (♀); 23, forewing, SEM of dorsal surface: 23a, entire, 23b, submarginal vein and costal cell (arrow points to costal setae) (♂); 24, forewing, photograph (♀). Scale bars = μm.

IDN. Canberra, nr. airport, 7.iv.53, 14.iv.53, ex. syrphid pupa *Eucalyptus melliodora*, E. Lewis; 8.iv.53, ex. syrphid pupa under *Euc. maculosa*, E. Lewis. Canberra, Black Mt., 22.v.53, ex. syrphid pupa *Euc. blakelyi*, E. Lewis; 14.iii.67, 9–16.xi.79, 17–26.xi.79, D.H. Colless; 2–10.iv.68, 28–29.iv.68, light trap; 18.xi.79, Z. Liepa; 600m, 7–12.iii.80, dry sclerophyll, A. Newton & M. Thayer; iii, iv, v, vii, ix, x, 24.x-1.xi, xi.82, IDN & JCC. Canberra, Capital Hill, coll. 21.x.53, em. 21.xi.53, ex. syrphid pupa *Euc. blakelyi*, F. Wheelhouse; ex. curled leaf *E. melliodora*, 9.iii.53, E. Lewis. Canberra, Farrer, 27.xi.80, 7.xii.80, R. Rentz. Gibraltar Falls, 27.i.84, IDN. Gingera, 6.iii.52, E.F. Riek. Ginninderra, 22.iii.66, G. Grant. Molonglo, 8.iv.83, ex. syrphid pupa under *Euc. maculosa*, E. Lewis. Mt. Coree, 30.i.64, D.H. Colless; 2 mi E, 19.xi.68, JCC & S. Curtis. Mt. Franklin, 4 km N (32.275 148.46E), 21.ii-10.v.77, D.C.F. Rentz. Mt. Gingera, 4.ii.65, D.H. Colless; 13.i.69, Z. Liepa; 21.ii.79, E.C. Zimmerman; 4.i.79, ex. lichen, R. Bartell. Picadilly Circus (35.225 148.48E), 1240m, xii.84, J. Lawrence, T. Weir & M.L. Johnson; (35.225 148.49E) 24.xi.81, JCC; 17 km SW (35.275 148.48E), 24.xi.81, IDN & JCC; 3 km E, Blundell's Ck (35.225 148.50), 850m, ii.84, xii.84, Weir, Lawrence & Johnson; ii.87, D.H. Colless; 6 km NW, Wombat Ck (35.195 148.51E), 750m, xii.84, i.85, Weir, Lawrence & Johnson. Quenbeyan, 9.iii.53, ex. curled leaf *E. melliodora*, E.L. Raymond; 2.7 km NE, 670m, 5.iv.80, I.F.B. Common. Smokers Flat, 6 km E Corin Dam, 4.iv.80, J.F. Lawrence. Woods Reserve nr. Gibraltar Falls, 27.i.84, IDN. **New South Wales:** Alpine Creek, Kian-dra, 9.xii.64, E.F. Riek. Arcadia, 10.ii.67, M.I. Nikitin (ASCU). Ardlethan, 31 km SE (34.375 147.01E), 10.ii.92, CJB (UQIC). Bald Rock Nat. Pk., 30.xi.81, M.A. Schneider & G. Daniels (UQIC). Barrington Tops S.F., Dilgry River (31.535 151.32E), 15–16.xi.81, T. Weir; Gloucester R (32.045 151.41E), 12–14.xi.81, T. Weir & A. Calder; Moppy Lookout (31.545 151.33E), 18.xi.81, T. Weir; 3km W Moppy Lookout (31.545 151.31E), 18.xi.81, T. Weir & A. Calder; Polbius Swamp, 17.xi.81, T. Weir; Thunderbolt's Lkt (31.555 151.30E), 18.xi.81, T. Weir & A. Calder. Batemans Bay, 4 N, 21.x.52, E.F. Riek. Bathurst, 1.v-21.v.62, R.D. Hughes; 23.ii.66, M.I. Nikitin (ASCU); 23.x.67 (ASCU); 26.x.68, N.C. Lloyd (ASCU). Billabong Ck nr. Conargo (35.175 145.11E), 12–17.iv.78, JCC. Boolijah Ck via Sassafras, 22.xi.79, JCC. Braidwood, 13 km NNW (35.215 149.44E), 5.xi.81, M.S. Upton. Brooklyn, 31.x.14 (QMBA). Broken Hill, 100 km SE (32.515 141.37E), 3–13.x.88, E.D. Edwards. Brown Mt., 15.i.69, JCC & S.R. Curtis. Bungendore, 13 km E (35.15 S 149.35E), 6.xi.81, M.S. Upton. Cabbage Tree Ck, Clyde Mt., 22.ii.65, D.H. Colless. Cabramatta, 1.i.63, M. Nikitin (QMBA). Condobolin, 17.x.00 (ASCU). Congo, 8 km SE Moruya, 15.ii.82, M.S. Upton. Coonabarabran, 51 km N (30.505 149.26E), 13.ii.92, CJB (UQIC). Dainers Gap (36.125 148.43E), 1585m, 19.xii.73, 28.xii.73, 6.ii.74, 20.iii.74, ex. *Eucalyptus pauciflora*, *stellulata* and

*perriniana* forest. Euroka, 4 km W Kempsey, 6.xii.78, A. Postle. Forbes, 12.xi.64, D.H. Colless. Fowlers Gap Res. Stn (31.055 141.42E), 29.xi-2.xii.81, 8–9.xii.82, IDN & JCC. Gibraltar Ra., 15.i.79, rainforest margin, IDN. Grafton, 5.iv.36, *Dicochrosia punctifloralis* (ASCU). Halfway House, Putty Rd., 20.xii.73, IDN (UQIC). Hunter R, 3.6 km on Glennies Ck Railway Rd, 12–13.xii.78, A. Postle & C. Brennan. Klora nr. Moruya, 6.iii.66, Z. Liepa. Kosciusko, Sawpit Ck, 11.xii.60, D.H. Colless. Lake George nr. Collector, 23.x.76, Z. Bouček (QMBA, USNM). Lansdowne, 3 km N, xi.91, riparian rainforest, blossom *Waterhousia floribunda*, G. & T. Williams. Lecton, 2.ii.66, M.I. Nikitin (ASCU). London Falls, 12.xii.48, C.E. Chadwick (ASCU). Macquarie Pass, 7 km ENE Robertson (34.345 150.40E), 8.ii.84, IDN. Monga State Forest, (35.385 149.54E), 3.xii.77, IDN; 18.ii.83, IDN & JCC. Monga, 5 km SW, 9.xi.81. Mootwingee Nat. Pk, Homestead Gorge (31.175 142.18E), 7–13.x.88, E.D. Edwards. Mt. Dromedary nr. Narooma, 2100 ft, 4.ii.69, Upton, Taylor & Cardale. Mt. Kaputar Nat. Pk., 2.xii.76, E.M. Exley; Dawsons Spring (30.175 150.10E), 1420m, 5–11.xii.87, moericke trap under flowering *Kunzea ambigua*, G.R. Brown (ASCU). Myalia Tank, 49 km NE Broken Hill (31.505 141.57E), 3.xii.81, IDN & JCC. Narrabri E.F., 19.ix.60, M.I. Nikitin (ASCU). New England NP, Point Lookout, 22.i.79, temperate rainforest, IDN & JCC. Orange, 22.ii.66, 23.ii.66, 14.iii.66, M.I. Nikitin (ASCU). Orchard Hills, W. Sydney, 26.v.82, K. Helm. Parkes, 13.xi.64, D.H. Colless. Pigeon House Ra. via Nerriga, 25.x, 22.xi.79, IDN & JCC. Scaly Lookout, nr. Coffs Harbour, 6.ix.83, G. Daniels & M. Schneider (UQIC). Terrace, 13.xii.78, A. Postle. Tooloom Plateau via Urbenville, 10.xi.74, IDN (UQIC). Triangle, 150–200m, 5–7.x.79, aerial netting, R. Farrow; Research Station, 4.xi.79, aerial net. Wambool Common, 18 km ESE Bathurst, 4.iv.80, JCC. West Wyalong, 17 km S (34.055 147.08E), 10.ii.92, CJB (UQIC). Yanco, 4.ii.60, M.I. Nikitin (ASCU). **Northern Territory:** Roe Creek, 11 km SW Alice Springs (23.465 133.47E), 9.x.78, JCC. **Queensland:** Applethorpe, 15.x.73, J. Rhodes (QDPI). Bald Mt. area via Emu Vale, 3500–4000', 27–31.i.72, S.R. Monteith. Biloela, 25 km E, 13.iii.76, E.M. Exley, on Ironbark (UQIC). Boonah, 29.xii.91, 17.vi.92, 18.vi.92 (UQIC); 16 km N (27.545 152.41E), 18.ix.94, 18–19.v.96, 6–7.ix.97, CJB (QMBA). Brisbane, 22.iii.40, C.F. Ashby (QDPI); 19.iv.52, S. Barker (UQIC); 5.xii.77, *Eucalyptus*, K. Walker (UQIC); iv.78, ex. syrphid larva, B. Cantrell (QDPI); Acacia ridge, 26.xii.76 (QMBA); Taringa (27.305 152.58E), coll. ii.98, em. 12, 13.iii.98, ex. pupa *Dideopsis aegrotata* on citrus, CJB (QMBA). Bunya Mts. Nat. Pk. nr. Westcott Plain (26.525 151.34E), 6–7.x.84, IDN & JCC. Charleville, nr. 13.iv.89, P. Johnson (QMBA). Chunchilla, 6 km W, 5–15.iii.98, G. Lithgow (QMBA). Cooloolo Nat. Pk., E Gympie, 18.x.78, I.D. Galloway (QDPI). Dayboro, 8.5 km SSE, Sampsonvale cemetery (27.165 152.52), 3.ix.95, 12.x.1997, CJB (QMBA). Eidsvold (25.225

- 151.07E), 11.x.84, IDN & JCC. Forest Hill, 18–19.xi.76, M. Tichon (UQIC). Gatton, 25.iii.80, P. Twine (QDPI); 11.v.81, 11.xi.81 (QDPI); D.P.I. Research Stn., 9–16.iii.81, 21–27.iv.81, 25.v–I.vi.81, 1–7.ix.81, 14–21.xi.81, 7–14.ix.81, 14–21.ix.81, 28.ix–5.x.81, 21.x.81 (QDPI). Gordonvale, ix.20, ex. puparia of cloudwinged syrphid, A.P. Dodd (QDPI). Joalah Nat. Pk., Tamborine Mt. (27.56S 153.12E), 18–21.x.78, Lawrence & Weir. Lemington Nat. Pk, Mt. Bithongabel, 1400m (28.16S 153.10E), 23.x.78, Berlese moss & litter *Notofagus moorvi*, Lawrence & Weir. Mitchell, bank of Mitchell Riv., 9.x.74, I.D. Galloway (QDPI). Monto, 14 km NW, 12.iii.76, on *Eucalyptus*, E.N. Exley (UQIC). Mt. Beerwah via Glasshouse, 1800', 5.xii.65, T. Weir (UQIC). Mt. Glorious, 31.xii.79, IDN; 19–26.xi.79, 24–31.xii.79 (QDPI); 22.iii.79, 7.xii.81, E.C. Dahms (QMBA); 3.i.82, B. Cantrell (QDPI); 22.vi–18.x.82, 27.iv.89, 27.iv–26.x.89, 26.x–5.xii.89, 1.ix–17.x.90, A. Hiller (QMBA); 17.x.90, E.C. Dahms & G. Sarnes (QMBA). Mt. Inkerman (19.45S 147.30E), 28.iv.97, CJB (QMBA). Mt. Nebo, xii.61, E. Warwick. Mt. Norman area via Wallangarra, 7–8.x.72, S.R. Monteith. Mt. Spurgeon, 2 km SSE (16.27S 145.12E), 1100m, 19–22.xi.97, CJB (QMBA). Mt. Superbus summit (28.14S 152.23E), 1270m, CJB (QMBA). Mt. Tamborine, x–xi.78, Sankowsky (QDPI); 3.iii.84, I.D. Galloway (QMBA). Ormiston, iii.61, ex. aphids, B.R. Champ (QDPI). Quilpie, 149 km E (26.33S 145.38E), 20.ix.90, M.P. Zalucki & G.V. Maynard (UQIC). Rathdowney (2nd Palen Ck. crossing from), 22.iii.75, I.D. Galloway (QDPI). Repulse Ck, 23 km NE Bauhinia Downs (24.24S 149.23E), 22–23.iv.81, IDN. Reyford, 26.v.78, E. Sinclair (QDPI). St. Lucia, University of Queensland, 12.xii.95, ex. pupa of Syrphidae on *Sonchus* sp., S.G. Evans (QMBA); 17.xii.95, adult ovipositing into pupa *Episyrphus viridaureus*, S.G. Evans (QMBA); 17.xii.95, ex. *Episyrphus* sp. pupa on *Sonchus oleraceus*, S. Evans (QMBA). Stanthorpe, 12 km SE, 3–30.xii.90, 3.iv–9.vi.91, G. Sarnes (QMBA); 47 km N, 9.xii.80, on *Eucalyptus*, E.M. Exley & J. King (UQIC). Taroom District (25.27S 150.03E), Boggomoss 21, 11.xi.96, CJB & S. Evans (QMBA). Thornlands, 1.xi.80, J.F. Donaldson (QDPI). Toowoomba, 28.ii.78, 29.ii.78, ex. Syrphidae pupa, B.A. Franzmann (QDPI). Whiskers, 7 km WNW Hoskistown (35.24S 149.23E), 29.xi.92, M.S. Upton. Wilson's Peak (nr), via Teviot Gap, 700–830m, 9.i.77, IDN (UQIC). Yatala, 24.xi–23.xii.81, among sugarcane, L.N. Robertson. Yerongpilly, 1–10.i.82, B. Cantrell (QMBA). **South Australia:** Adelaide, reared ex. *Melangyna viridiceps* (Macq.), M. Carver; 50 km S, Aldinga Scrub, 5–6.xii.86, JSN. Brookfield Cons. Pk. (34.21S 139.29E), 24–26.xi.92, IDN & JCC; SW corner, stop 29 (34.24S 139.26E), 20.x.92, Rentz, Roach & Harwood. Cowell, 32 km NNE (32.26S 137.03E), 28.xi.92, IDN & JCC; 43 km NNE (33.20S 137.06E), IDN & JCC. nr. Lake Eyre South (29.31S 137.16E), JCC. Lake Tungketta (33.46S 135.06E), 30.xi.92, IDN & JCC. Lock, 24 km NW (33.32S 135.30E), 30.xi.92, flowers *Eucalyptus*, IDN & JCC. Mermerna, 33 km N Hawker (31.36S 138.23E), 17.ix.78, JCC. nr. Moonabbie Range (33.17S 137.10E), IDN & JCC. Oraparainna Ck, Dingley Dell Camp (31.21S 138.42E), 4–10, 7.xi.87, IDN & JCC. Orroroo (32.44S 138.37E), 11.xi.87, IDN & JCC. Parachilna Ck (31.08S 138.33E), 8.xi.87, IDN & JCC. Parra Wirra Rec. Pk, 50 km NE Adelaide, 9.xii.86, JSN. Penong, 10 km WNW (31.53S 132.54E), 14.x.81, IDN & JCC. nr. Pine Hill (33.22S 137.03E), 28.xi.92, IDN & JCC. Pinnaroo, 18 km SSW (35.25S 140.49E), 20.x.83, 24.x.83, IDN & JCC; 25 km SSW (35.28S 140.47E), 20.x.83, 24.x.83, IDN & JCC; 49 km SW (35.42S 140.49E), 20, 24.x.83, IDN & JCC. Port Lincoln, 4 km SW (34.45S 135.49E), 29.xi.92, IDN & JCC. Willmington, 2 km SSE (32.39S 138.06E), 11.xi.87, IDN & JCC. **Tasmania:** Bronte Lagoon, 13.i.84, L. Masner (CNCI). Bronte Pk., 12 km NNE (42.02S 146.33E), 2.ii.83, IDN & JCC. Buckland, 5 km W (42.37S 147.39E), 27.i.83, IDN & JCC. Claytons, Bathurst Harbour (43.22S 146.08E) 15.i.91, Nielson & Edwards. Condominium Ck, 5 km WSW Anne (42.58S 146.22E), 11.xii.81, IDN & JCC. Cranbrook, 14 km ESE (42.04S 148.13E), 28.i.83, IDN & JCC. Denson rivulet, N of Bicheno (41.48S 148.15E), 6.ii.92, CJB (UQIC). Derwent Bridge, 9 km WSW (42.10S 146.08E), 21.i.83, IDN & JCC; 18 km SW (42.13S 146.02E), 22.i.83, IDN & JCC. Elephant Pass (41.38S 148.13E), 28.i.83, IDN & JCC. Fentonbury, 1 km W (42.39S 146.45E), 12.xii.81 Franklin R. (42.13S 146.01E), 2.ii.83, IDN & JCC. Frodshams Pass (42.49S 146.23E), 24–25.i.83, IDN & JCC; 7 km S (42.53S 146.22E), 25.i.83, IDN & JCC; 5 km SW (42.50S 146.19E), 24.i.83, IDN & JCC; 8 km SW (42.49S 146.18E), 24.i.83, IDN & JCC. Hellyer Gorge, 2.ii.67, E.F. Riek. Herrick, 1 km NE (41.06S 147.53E), 29–30.i.83, IDN & JCC. Kingston, 1 km NE, 26.xii.79, JCC. Mayfield Beach (42.15S 148.00E), 6.ii.92, CJB (UQIC). Miena, 6 km W (41.59S 146.39E), 20.i.83, IDN & JCC. Montumana, 3 km SE (40.58S 145.33E), 19.i.83, IDN & JCC. Mt. Barrow via Launceston, 800–1000m, 1.xii.76, IDN (UQIC). Mt. Doris (41.52S 146.03E), 7.ii.90, coniferous heath, IDN. Mt. Mueller, 5 km NW (42.46S 146.25E), 11.xii.81, IDN. Mt. Wellington, Shoobridge Bend (42.54S 147.15E), 5.ii.83, IDN & JCC. Nelson R. (42.06S 145.44E), 22.i.83, IDN & JCC. Nunamara, 10 km ENE (41.22E 147.24E), 11.i.83, IDN & JCC; 8 km NE, Barrow Ck (41.21S 147.22E), IDN & JCC; 11 km NE, Mt. Barrow (41.23S 147.25E), 11.i.83, IDN & JCC. Oxford, 4 kmW (42.34S 147.50E), 27.i.83, IDN & JCC. Pellon Hut, 3 km S Mt. Oakleigh (41.50S 146.03E), iii.91, *Leptospermum* scrub and vicinity, IDN; 30.xi–8.i.91, open forest; 5–10.ii.90, rainforst, IDN. Poatina, 9 km SW (41.48S 146.52E), 20.i.83, IDN & JCC; Headrace Adit (41.49S 146.54E), 20.i.83, IDN & JCC. Scottsdale, 9 km E (41.10S 147.38E), IDN & JCC. The Lea (42.56S 147.19E), 5.ii.83, IDN & JCC. Wayatinah, 3 km NE (42.22S 146.29E), 15, 23.i.83, IDN & JCC. Weldborough, 4 km SE (41.14S 147.56E), 13.i.83, IDN & JCC. **Victoria:** Acheron Gap, c. 15 km NNE

Warburton, 830m, malaise *Nothofagus*, D. Pollock & L. Reichert. Archeron Way via Warburton, 300–480m, 16.xii.75, IDN (UQIC). Beech Forest, 10 mi E, 1.i.67, Z. Liepa; via Colac, 6.i.66, T. Weir (UQIC); Coultts Rd., 480m, 11.xii.75, IDN (UQIC). Belgrave, 25, 26.xii.26, A.P. Dodd (QDPI). Bogong Plains, 5–6000 ft, i.28, F.E. Wilson (QDPI). Bruthen, 26.ii.80, IDN & JCC; 9 km N (37.38S 147.53E), 8.ii.92, CJB (UQIC). Cann Valley H'way, 7 km SW N.S.W. border, 25.ii.80, IDN & JCC. Dinner Plain, 11 km from Hotham Heights, 27.ii.80, IDN & JCC. Hattah, 12 km NW (34.39S 142.14E), 19.x.83, IDN & JCC. Jim Jack Ck, 12 km WSW Omeo, 27.ii.80, IDN & JCC. Kiata, 8 km SSW (36.26S 141.46E), 23.x.83, IDN & JCC. Kinglake N. Pk. nr. Melbourne, 31.i.77, Bouček (USNM). Lake Crosby (35.03S 141.44E), 23.x.83, IDN & JCC. Lind Nat. Pk., Growler Ck, 26.ii.80, IDN & JCC. Mitre, 11km NE (36.38S 141.48E), 22.x.83, IDN & JCC; 12.5 km NNE (36.37S 141.49E), 22.x.83, IDN & JCC. Mitta Mitta Ck, 25 km NNW Omeo, 28.ii.80, IDN & JCC. Mt. Arapiles (36.46S 141.50E), 21.x.83, IDN & JCC. Mt. Donna Buang, 1250m, 14–17.i.80, *Eucalyptus* woodland, A. Newton & M. Thayer (CNCI); via Healesville, 4080 ft, 10.i.66, T. Weir (UQIC); via Warburton, 1200m, 8.xii.76, IDN (UQIC). Mt. Sabine via Barramunga, 580m, 11.xii.75, IDN (UQIC, QDPI). Omeo, 12 km NNW, 28.ii.80, IDN & JCC; 18 km NW, 28.ii.80, IDN & JCC. Pirita, 13 km S (34.29S 141.54E), 18.x.83, IDN & JCC. Rye, 27.ii.89, ex. *Dialectica* sp. A on *Cynoglossum australe*, R. Sheperd. Yapest, 10 km NW (35.41S 142.02E), 23.x.83, IDN & JCC. Yarrara, 15 km S (34.33S 141.25E), 18.x.83, IDN & JCC. **Western Australia:** Boranup Karri Forest, 20 km S Margareb River, 11–13.xii.90, A.D. Austin (WARI). Cape Arid NP, 30.xii.86–31.i.87, JSN; Yokinup Bay area, 31.xii.86–3.i.87, JSN. Cape Le Grand Nat. Pk. (33.58S 122.07E), 10.i.87, 11.i.87, G. & A. Daniels (UQIC). Condingup, c. 55 km E Esperance, 31.xii.86, JSN. Dongara, 30 km S., 19.xii.86, JSN. Esperance, 4.i.87, JSN. Fitzgerald Riv. Nat. Pk., Quaalup area, 6–9.i.87, JSN. John Forest NP, c. 25 km E. Perth, 23–27.xii.86, 24–28.xii.86, JSN. Ludlow (33.37S 115.29E), 2.xi–23.xii, S.J. Curry. Nedlands, 10.iv.41, from syrphid pupa on rose leaf, K.R. Norris. Needilup, 29 km NE (33.54S 119.04E), 30.x.84, A.A. Calder. Noongar, 2 km SW (31.21S 118.57E), IDN & JCC. Pithara, 2 km SSW (30.24S 116.40E), 26.ix.81, IDN & JCC. Porongorup Nat. Pk., 1.87, JSN. Ravensthorpe, 4.i.87, JSN. Stirling Range Nat. Pk., i.87, JSN. Swan River, G. Compere (QMBA); Red Gum Spring, 23 km ENE Cranbrook, 20–22.xii.90, A.D. Austin (WARI). Walpole-Nornalup Nat. Pk., 17–21.i.87, JSN; Nornalup, 5 km SE, 17–18.xii.90, A.D. Austin (WARI); Nornalup, 2 km W (34.59S 116.48E), 17.i.93, E.D. Edwards. Yanchep Nat. Pk., c. 50 km N Perth, 20.xii.86, JSN; c. 65 km N Perth, 21.xii.86, JSN. Yellowdine, 21 km NE (31.17S 119.53E), 10.x.81, IDN & JCC.

*Hosts.*—Label data indicate *Aphis crac-*

*civora* (Koch) (Aphididae) and puparia of *Dideopsis aegrota* (Fabricius), *Episyrphus viridaureus* Wiedemann and *Melangyna viridiceps* (Macquart) (Diptera: Syrphidae) as hosts of *P. emersoni*. There is also one anomalous record from *Dialectica* sp. (Lepidoptera: Gracillaridae).

*Remarks.*—*Pachyneuron emersoni* is distinguished by a combination of features that are given in the key and description. I have seen females, most commonly from Western Australia, that lack a marginal fringe and therefore resemble *P. nelsoni*. In some instances one or more short regions of the wing margin retain setae so absence may simply be due to abrasion; however, either the setae are for some reason more readily lost from females from western Australia or presence or absence of the setae is variable for *P. emersoni* in western Australia. Females without a marginal fringe are differentiated from *P. nelsoni* females by their conspicuously longer marginal and postmarginal veins (*cf.* Figs. 24 and 36), smoother and shinier medial area on the propodeum (*cf.* Figs. 15 and 29), and more elongate petiole that in dorsal view is uniformly reticulate (*cf.* Figs. 22 and 27). All males of *P. emersoni* that I have seen have a marginal fringe but those from western Australia often have the lower face only inconspicuously depressed lateral to the supraclypeal area (Fig. 17), much less so than for typical specimens from eastern and southern Australia (Fig. 16). The western Australian males are thus more like males of *P. rieki*, but they do not have the setal patterns of the forewing basal fold or the scape as described for *P. rieki* males. Also, even though the facial region may be only indistinctly depressed (Fig. 17), there is still a noticeable difference in the reticulate sculpture compared with that near the eye, the cells being smaller and often more obliquely oriented in the depressed regions (Fig. 18). I have also seen rare males of *P. emersoni* from eastern Australia and Tasmania that have a single petiolar seta

projecting from one side, but these males have the lower face distinctly depressed lateral to the supraclypeal area and the basal fold bare.

Individuals of *P. emersoni* are morphologically very similar to those of *P. formosum* Walker (1833) in Europe and *P. albutius* Walker (1843) in America north of Mexico. However, the propodeum is uniformly reticulate in *P. formosum* females and reticulate with a network of oblique, irregular carinae in *P. albutius* females. Females of both species lack the more or less W-shaped complex of plicae and costulae and the smoother posteromedian region characteristic of *P. emersoni* females (Fig. 15). Males of *P. formosum* and *P. albutius* also have the lower face essentially evenly convex and uniformly reticulate.

Bouček (1988) previously suggested that *P. kingsleyi* was only a form of *P. emersoni* but did not formally synonymize the names. The female lectotype is complete, but the antennae are mounted on a slide under a separate cover slip from the head and antennae of the USNM male paralectotype (Dahms 1983).

### *Pachyneuron nelsoni* Girault (Figs. 25–36, 51)

*Pachyneuron nelsoni* Girault, 1928[421]: 2. Holotype female (examined). Type data: Australia: N. Q., Gordonvale [= Nelson], Feb. 1920, Dodd. Type depository: QMBA, type no. T.9324. Sex described: female.

*Pachyneuron aeneus* Masi, 1929: 229–231. Holotype female. Type data: Libya (North Africa): Oasis of Giarabub, iii.1927. Type depository: Museo Civico di Storia Naturale, Genoa. Sex described: female. Synonymy by Bouček, 1988: 442.

*Atrichoptilus aeneus*; Delucchi, 1956: 141–142. Change of combination.

*Pachyneuron aeneum*; Bouček, 1965: 16–18. Change of combination.

*Pachyneuron nelsoni*; Dahms, 1986: 324–325; Bouček, 1988: 442.

*Female*.—Body dark with variably distinct metallic green luster; antenna brown except basal half to all of scape yellow; te-

gula yellow; legs with femora variably darkly infuscate except apically yellowish, tibiae and tarsi yellowish. Head with clypeus flat to slightly depressed and apically shallowly emarginate (Fig. 25). Flagellum compact-clavate, with 2 anelli (Fig. 32) and 6 funicular segments (Fig. 31); funicular segments quadrate or slightly longer than wide basally to slightly transverse apically and with adpressed setae (Figs. 31, 32); longitudinal sensilla extending almost entire length of funicular segments, separated from each other by distance equal to 1–2 sensillar diameters (Fig. 32). Forewing (Figs. 35, 36) without marginal fringe; with relatively inconspicuous, white, often spicule-like discal setae; dorsally without line of setae differentiating apex of basal cell from speculum; ventrally without line of setae along cubital fold; costal cell with inconspicuous white setae on ventral surface (Fig. 35b); veins with following ratios ( $n = 10$ ):  $smv/mv = 4.33\text{--}5.00$ ,  $mv/mvw = 1.64\text{--}2.22$ ,  $pmv/mv = 1.25\text{--}1.78$ ,  $pmv/stv = 1.04\text{--}1.10$ . Mesonotum with relatively low convex, broad scutellum (Fig. 26). Propodeum (Figs. 26, 29) with posteriorly convergent, carinately margined plical ridges and  $\wedge$ -shaped to inverted Y-shaped carinae differentiating a more or less W-shaped anterolateral region and a pentagonal posteromedian region, with all surfaces similarly coriaceous-reticulate or with pentagonal region more distinctly reticulate; spiracle distinctly oval. Petiole without setae projecting from sides (Figs. 27, 28); in dorsal view slightly (up to about 1.3 times) longer than wide, with often indistinctly differentiated, transverse to quadrate, rugose-reticulate body often having median carina or some longitudinal carinae (Fig. 27); in ventral view completely sclerotized with median furrow, the body quadrate to slightly transverse, finely longitudinally coriaceous and shiny (Fig. 28).

*Male*.—Similar to female except as follows: body brighter metallic green or bluish green; antenna almost uniformly yel-

lowish or with flagellum light brown; legs uniformly bright yellow beyond coxae; scape (Fig. 34) thickest basally and tapered toward apex, with anterior surface flat to slightly concave over at least basal two-thirds and in lateral view with variably distinct line of setae along both outer and inner anterior margins; flagellum filiform; funicular segments oblong, middle segments at most 1.75 times as long as wide and all segments with very sparse longitudinal sensilla within apical half of each segment and with conspicuous, semierect setae about as long as width of segment (Fig. 33). Forewing with marginal vein up to 2.6 times as long as wide and postmarginal vein up to 1.4 times as long as stigmal vein; sometimes with 1 or 2 short setae on dorsal surface of basal fold and sometimes with a few short, inconspicuous setae on dorsal surface within basal cell. Propodeum often more uniformly reticulate with fine or indistinct plical and  $\wedge$ -shaped carinae (Fig. 29).

*Distribution.*—Noyes (1998) recorded *P. nelsoni* from the following regions and countries: Afrotropical (Libya), Australasian (Australia), Oriental (India), and Palearctic (Moldova, Russia, Turkey). The species was additionally recorded from Yugoslavia and Azerbaijan by Bouček (1977: 46), who stated that it is circum-mediterranean. Bouček (1988) stated that it is widespread in southern Europe, dry countries of Africa and south Asia, and established (probably introduced) in Australia.

Australian distribution (Fig. 51) records based on label data of examined specimens are: **Australian Capital Territory:** Brindabella Range, Mt. Ginini (35.32S 148.46E), 24.xi.81, IDN. Canberra, 23.xii.30, W.K. Hughes. **New South Wales:** Bowning, nr, 9.xii.69, on *Eucalyptus*, JCC. Fowlers Gap Res Stn (31.05S 141.42E), 29.xi-2.xii.81, on *E. camaldulensis* flowers, JCC; 8-9.xii.82, JCC. Leeton, 3.ii.66, M.I. Nikitin (ASCU). Mootwingee Nat. Pk., Old Mootwingee Gorge, 5-8.xi.84, G.R. Brown & H.M. Holmes (ASCU). Myalla Tank, 49 km NE Broken Hill (31.50S 141.57E), 3.xii.81, IDN & JCC. Orange, 22.ii.66, M.I. Nikitin (ASCU); Agric. Res. Stn., 18.viii.93, on

apple blossom, K. Harding & A. Nicholas (ASCU). Triangle, 5-7.x.79, aerial netting 150m, 200-300m, R. Farrow; i-iii.85, S.G. Martin, ex. lucerne (ASCU); Research Station, 1.xi.79, 4.xi.79, aerial net. Wamboon Common, 19 km ESE Bathurst, 17.iv.81, JCC. **North-Territory:** Alice Springs, 20.ix.78, ex. syrphid pupa, L. Rodunz; 7 km NW (23.38S 133.52E), 8.xi.79, JCC; 10 km NE (23.37S 133.54E), 6.xi.79, IDN; 35 km E (23.41S 134.13E), 25.ix.78, JCC; 39 km E (23.41S 134.15E), 25.ix, 5.x.78, JCC; 40 km E (23.41S 134.16E), 5.x.78, JCC; 53 km NE (23.35S 134.22E), 6.x.78, JCC; 56 km SE (24.11S 134.01E), 3.x.78, JCC. Ayers Rock, 195 km E on Lacsiters Highway, 5.xi.92, P. Dangerfield (WARI). **Queensland:** Bramston Beech (17.21S 146.01E), 14.xii.91, CJB (UQIC). Brigalow Development area, Moura, P.D. Rossiter [S. alnum, 21.iv.66] (QDPI). Chinchilla, 6 km W, 9-17.x.87, G. Lithgow (QMBA). Connors River (22.11S 149.03E), 8.v.80, IDN & JCC. Eulo, 32 km W (28.09S 144.43E), 28.x.91, G. Daniels, on *Flindersia maculosa* (UQIC). Gatton College Cawes, 30.xi.67, ex. syrphid pupa, B. Teakle (QDPI). Gordonvale, 20.ii.20, A.P. Dodd (QMBA). Holts Ck, 8 km N Musselbrook Camp (18.33S 138.11E), 20.v.95, IDN. Miles, 28 km S, 23.ix, D.H. Colless. Mount Inkerman (19.45S 147.30E), 28.iv.1997, CJB (QMBA). Taroom District (25.27S 150.03E), Boggomoss 21, 11.xi.66, CJB & S. Evans (QMBA). Townsville, Ross River, Hermit Pk. (19.18S 146.49E), 4.xii.91, CJB (UQIC). Warwick, 9 km S, 13.i.81, J. & C.R. King, on *Angophora costata* (UQIC). **South Australia:** Agnes Ck, 44 km NW Granite Downs (26.38S 133.16E), 21.ix.78, JCC. Aldinga Scrub, 50 km S Adelaide, 5-6.xii.86, JSN. Brookfield Cons. Pk. (34.21S 139.28E), 24.xi.92, 26.xi.92, IDN & JCC. Ceduna, 21 km NW (31.56S 133.24E), 14.x.81, IDN & JCC; 32 km NW (31.56S 133.24E), 14.x.81, IDN & JCC. nr. Coffin Bay (34.38S 135.27E), 29.xi.92, IDN & JCC. Cowell, 43 km NNE (33.20S 137.06E), 28.xi.92, IDN & JCC. Edwards Creek (28.20S 135.50E), 19.ix.78, JCC. Elliston, 1 km SE (33.40S 134.54E), 30.xi.92, IDN & JCC. nr. Lake Eyre South (29.31S 137.16E), 18.ix.78, JCC. nr. Moonabbie Range (33.17S 137.10E), 28.xi.92, IDN & JCC. Nooltana Creek, 13 km NW Hawker (31.47S 138.21E), 16.ix.78, JCC. Oraparinna Ck, Dingly Dell Camp (31.21S 138.42E), 7.xi, 4-10.xi.87, IDN & JCC. Parachilna Ck (31.08S 138.33E), 8.xi.87, IDN & JCC. Penong, 10 km WNW (31.53S 132.54E), 14.x.81, IDN & JCC. Pinnaroo, 18 km SSW (35.25S 140.49E), 20 & 24.xi.83; 25 km SSW (35.28S 140.47E), 20 & 24.xi.83, IDN & JCC; 49 km SW (35.42S 140.49E), 20 & 24.xi.83, IDN & JCC. Taylorville, 12 km ESE (34.08S 140.06E), 12.xi.87, IDN & JCC. William Creek, 27 km SE (29.05S 136.31E), 19.ix.78, JCC. Wilmington, 2 km SSE (32.39S 138.06E), 11.xi.87, IDN & JCC. Yorke Peninsula, 20.ix.81, aerial netting, R.A. Farrow. **Tasmania:** Frodshams Pass, 1 km S (42.50S 146.22E), 11.xii.81, IDN. **Victoria:** Hattah, 7 km SE (34.50S 142.18E), 19.x.83, IDN & JCC; 12 km NW (34.39S 142.14E), 19.x.83, IDN

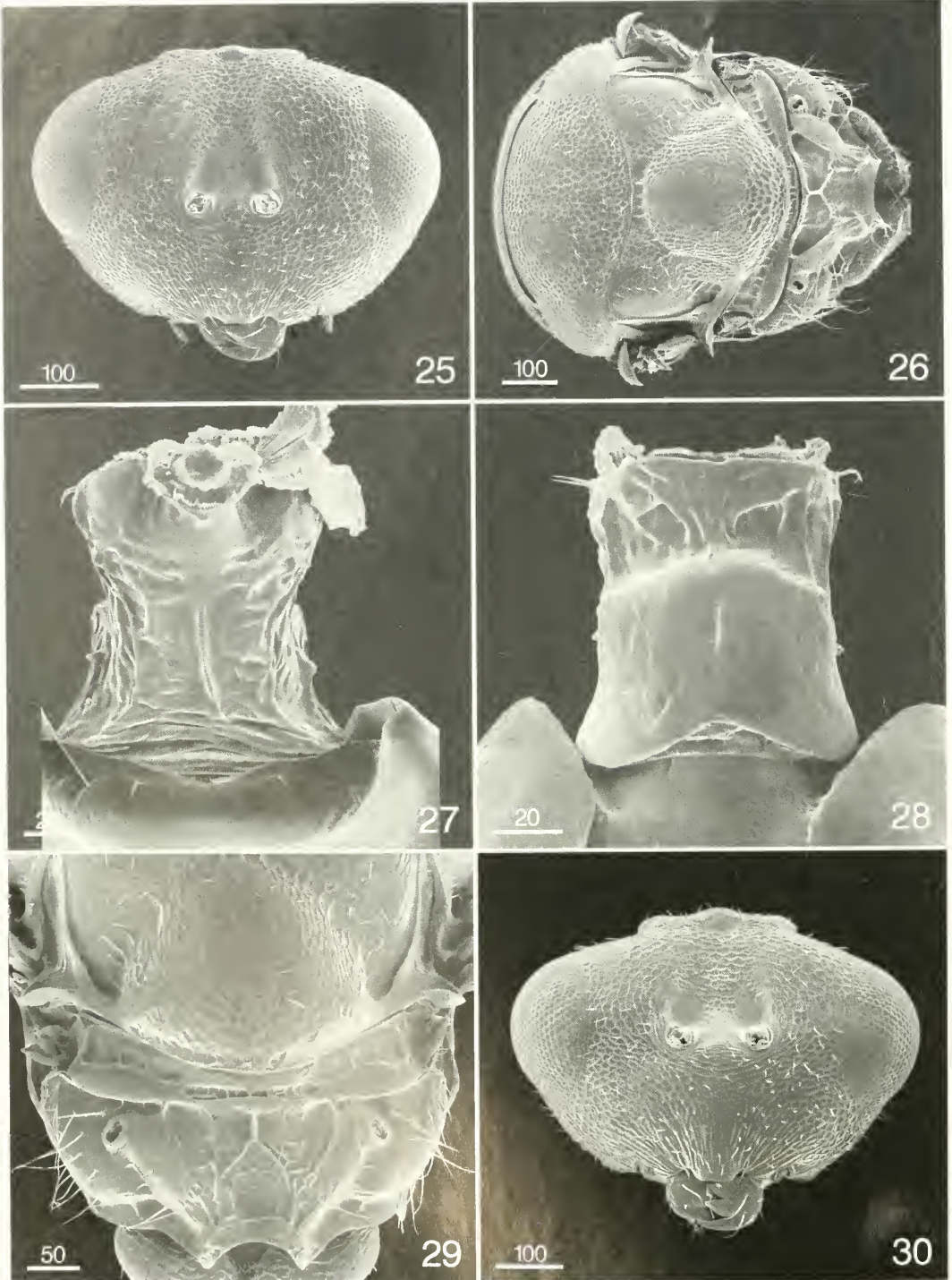

Figs. 25–30. *Pachyneuron nelsoni*: 25, head, frontal (♀); 26, mesosoma, dorsal (♀); 27, petiole, dorsal (♀); 28, petiole, ventral (♂); 29, scutellum-propodeum (♀); 30, head, frontal (♂). Scale bars =  $\mu\text{m}$ .

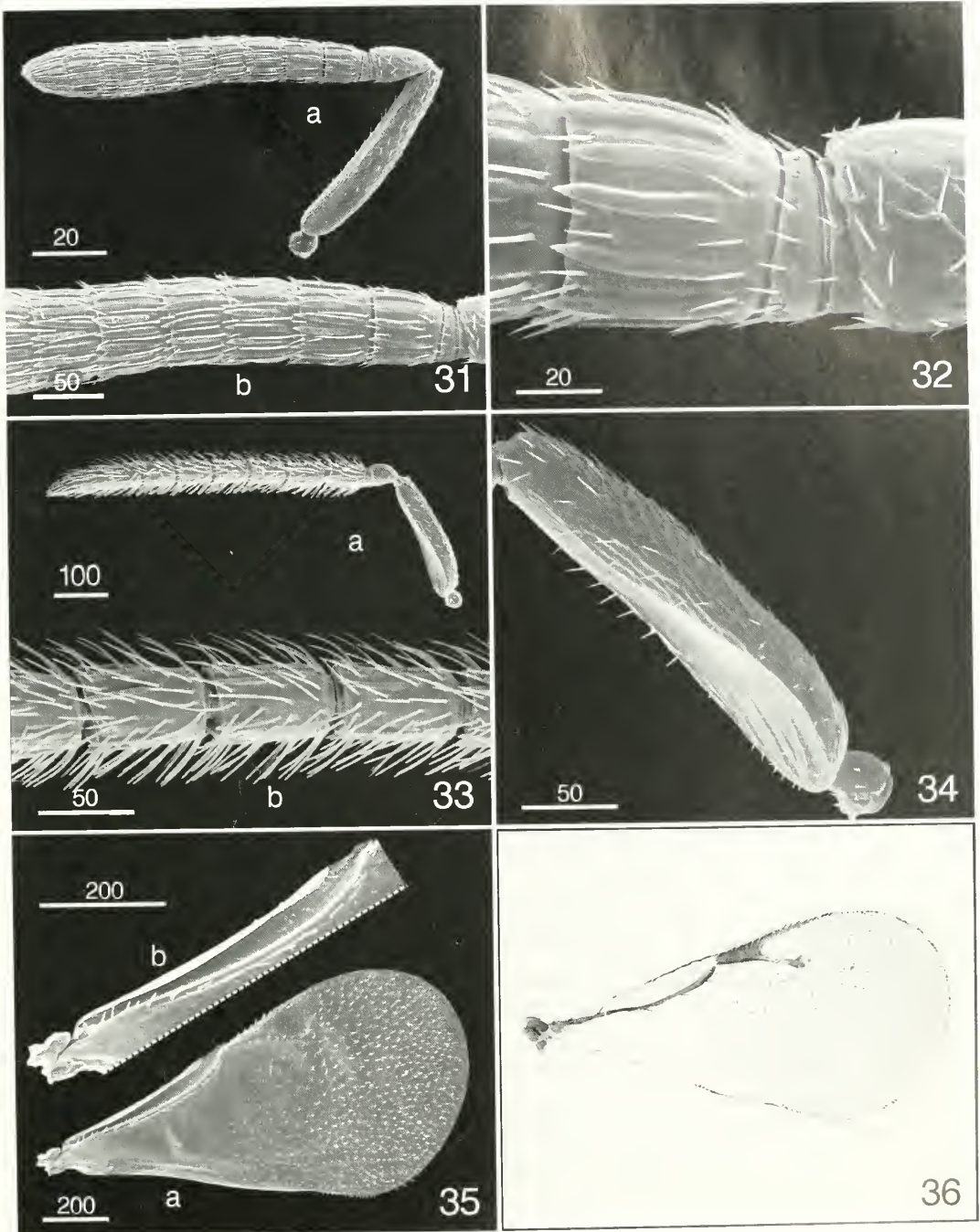

Figs. 31–36. *Pachyneuron nelsoni*: 31, antenna (♀): 31a, entire, 31b, anelli and funicular segments; 32, basal flagellar segments, fl.-fl. (♀); 33, antenna (♂): 33a, entire, 33b, middle funicular segments, fl.-fl.; 34, scape (♂); 35, forewing, SEM of dorsal surface: 35a, entire, 35b, submarginal vein and costal cell (♂); 36, forewing, photograph (♀). Scale bars = μm.

& JCC. Kiata, 8 km SSW (36.26S 141.46E), 23.x.83, IDN & JCC. Lake Crosby (35.03S 141.44E), 23.x.83, IDN & JCC. Mitre, 11 km NE (36.38S 141.48E), 22.x.83, IDN & JCC; 12 km NE (36.37S 141.48E), 22.x.83, IDN & JCC; 12.5 km NNE (36.37S 141.49E), 22.x.83, IDN & JCC. Mt. Arapiles (36.46S 141.50E), 21.x.83, IDN & JCC. Pirita, 13 km. S (34.29S 141.54E), 18.x.83, IDN & JCC. Princetown, 5 km NW, 27.xi.77, J.F. Donaldson (QDPI). Yapest, 10 km NW (35.41S 142.02E), 23.x.83, IDN & JCC. Yarrara, 15 km S (34.33S 141.25E), 18.x.83, IDN & JCC. **Western Australia:** Cocklebiddy, 23 km ESE (32.08S 126.18E), 12.x.81, IDN & JCC. Fitzgerald Riv. Nat. Pk., Quaalup area, 6–9.i.87, JSN. Geraldton, 31.xii.75, R. Storey & E.M. Exley (UQIC). Kalgoorlie, 1.xi.47, swept nr. Lucerne. Ludlow (33.37S 115.29E), 4.xi–22.xii.80, S.J. Curry. Madura, 11 km E (31.55S 127.09E), 13.x.81, IDN & JCC. 'Marun' CALM Site, 8/4 Prince Frederick Harbour (15.00S 125.21E), 6–11.vi.88, IDN. Mt. Magnet, 17.xii.86, JSN. Mt. Singleton, 15 km NE (29.21S 117.20E), 28–29.ix.81, IDN & JCC. Noongar, 2 km SW (31.21S 118.57E), 9.x.81, IDN & JCC. Norseman, 47 km SSW (32.35S 121.34E), 19.ix.81, IDN & JCC. Paynes Find, 5 km SW (29.18S 117.39E), 29.ix.81, IDN & JCC. Perenjori, 18.xii.86, JSN. Ravensthorpe, 46 km W, 4.i.87, JSN. Yanchep N.P., 20–21.xii.86, J.S.N.; c. 50 km N Perth, on *Eucalyptus*, 20.xii.86, JSN.

*Hosts.*—Noyes (1988) gave Syrphidae (Diptera) as the hosts of *P. nelsoni*, but without listing any species; Bouček (1977: 46) listed *Episyrphus* (= *Epistrophe*) *balteatus* (DeGeer) as an example syrphid host. Label data also indicate syrphids as the hosts of *P. nelsoni* in Australia, but exact species are unknown.

*Remarks.*—Individuals of *P. nelsoni* are most similar to those of *P. emersoni* and *P. rieki* but are distinguished by the lack of a marginal fringe (Figs. 35, 36) in combination with a comparatively short and thick marginal vein and a shorter postmarginal vein (Fig. 36). Individuals also differ slightly in propodeal sculpture from those of *P. emersoni* and *P. rieki*, the propodeum having a  $\wedge$ -shaped or inverted Y-shaped median carina delineating a posteromedian pentagonal region that is similarly or even more conspicuously sculptured than is the basolateral W-shaped region (Figs. 26, 29). Individuals of *P. emersoni* and *P. rieki* usually have the posteromedian region more broadly  $\cap$ -shaped, shiny, and almost smooth (Figs. 15, 39, 40). The pet-

iole (Fig. 27) is also shorter than in *P. emersoni* (Fig. 22) or *P. rieki* (Fig. 41), but because of its length it is often mostly concealed by the base of the gaster. Antennal features further differentiate males of *P. nelsoni* from those of *P. emersoni* and *P. rieki*, the scape having a flat to shallowly concave anterior surface that is broad basally and tapered apically (Fig. 34), and the flagellar segments being comparatively short (Fig. 33) and usually similarly light-colored as the scape.

The specimen from near Chinchilla, Queensland (QMBA) is a gynandromorph, having the head and antennae of a male but the metasoma of a female.

Doğanlar (1986) differentiated *P. nelsoni* (as *P. aeneum*) from other European species of *Pachyneuron* based on structure of the hypopygium and described the new species *P. erzurumicum*, from Turkey, as lacking a marginal fringe. He differentiated the latter species from *P. aeneum* based on differences in dimensions of the forewing venation and flagellar segments. Huang and Liao (1987) also described a new species from China, *P. aciliatum*, as lacking a marginal fringe. They compared the species with *P. grande* Thomson but did not differentiate it from *P. nelsoni*, though they illustrated a forewing with seven setae on the basal fold, three setae within the basal cell, and with distinct discal setae.

#### *Pachyneuron rieki* Gibson, new species (Figs. 37–49)

*Type material.*—*Holotype*, female (ANIC): Australian Capital Territory: Flea Ck, 25.viii.1950, E.F. Riek. *Allotype*, male (ANIC): same data as holotype. *Paratypes* (ANIC, UQIC, CNCI): **Australian Capital Territory:** 7 females, 13 males, same data as holotype, the series associated with an unidentified syrphid larva (1 female and 2 males used for SEM). **Tasmania:** Lake St. Clair (42.06S 146.10E), 750m, 25–27.i.1980, Lawrence & Weir (1 female). Mt. Doris (41.52S 146.03E), 7.ii.1990, coniferous

heath, IDN (1 male); 1 km ENE Mt. Ossa (41.52S 146.03E), iii.1991, IDN (2 males).

*Etymology*.—Named in honour of Edgar F. Riek, who reared most of the type series.

*Female*.—Body dark with metallic green luster; antenna dark brown except scape yellow; tegula yellow; legs with all except apex of femora brown, otherwise yellowish beyond coxae. Head with clypeus flat and apically shallowly emarginate (Fig. 47). Flagellum compact-clavate, with 2 anelli (Fig. 44) and 6 funicular segments (Fig. 43); funicular segments distinctly longer than wide basally to quadrate apically and with adpressed setae (Figs. 43, 44); longitudinal sensilla extending most of length of funicular segments, separated from each other by distance equal to about 2 sensillar diameters (Fig. 44). Forewing (Fig. 48) with marginal fringe; with distinct discal setae; dorsally with oblique line of 7–13 setae on basal fold differentiating apex of basal cell from speculum and with 2–5 setae near apex of basal cell; ventrally without line of setae along cubital fold; costal cell with distinct setae on ventral surface; veins with following ratios ( $n = 3$ ):  $smv/mv = 3.33\text{--}3.45$ ,  $mv/mvw = 4.83\text{--}5.00$ ,  $pmv/mv = 1.60\text{--}1.76$ ,  $pmv/stv = 1.65\text{--}1.76$ . Mesonotum with relatively low convex, broad scutellum (Figs. 38, 39). Propodeum (Figs. 39, 40) with posteriorly convergent, carinately margined plical ridges and less distinct, sometimes irregularly  $\cap$ -shaped antero-median carina or ridge (costula) near base (Fig. 39), the ridges together differentiating a more or less W-shaped basal region with coriaceous sculptured anterolateral depressions from a mostly shiny and smooth to finely coriaceous pentagonal or hexagonal posteromedian region anterior to a coriaceous or medially smooth and shiny nucha, with the short region anterior to  $\cap$ -shaped ridge crenulate and the surface lateral to plical ridges finely coriaceous (Fig. 40); spiracle distinctly oval. Petiole near middle with 1–3 setae pro-

jecting anterolaterally from each side (Figs. 41, 42); in dorsal view about twice as long as wide, with distinctly longer than wide, uniformly reticulate body (Fig. 41); in ventral view completely sclerotized with median furrow, the body distinctly longer than wide, finely longitudinally coriaceous and shiny (Fig. 42).

*Male*.—Similar to female except as follows: body brighter metallic green or bluish green; legs uniformly bright yellow beyond coxae; scape entirely yellow, slightly expanded basally immediately above radicle, tapered subapically and slightly curved, with line of distinct setae along anterior margin (Fig. 46); pedicel sometimes yellow except brownish dorsally; flagellum dark brown, filiform; funicular segments elongate, the middle segments at least twice as long as wide and all segments with very sparse longitudinal sensilla within apical half and with conspicuous, semierect setae about as long as width of segment (Fig. 45); forewing with basal fold similarly setose as in female but sometimes also with 1–3 setae delineating posteroapical angle of basal cell and with up to 10 setae within cell behind submarginal vein and toward apex; veins with following ratios ( $n = 6$ ):  $smv/mv = 2.70\text{--}3.23$ ,  $mv/mvw = 3.84\text{--}4.86$ ,  $pmv/mv = 1.30\text{--}1.74$ ,  $pmv/stv = 1.52\text{--}1.79$ ; petiole sometimes without lateral setae (see remarks).

*Hosts*.—Unknown species of Syrphidae (Diptera).

*Remarks*.—This species is most similar to *P. emersoni*, but is distinct based on features used to separate the species in the key and descriptions, and as discussed under the remarks for *P. emersoni* and *P. nelsoni*. The three males from Tasmania have a slightly shorter petiole than the reared males from ACT and apparently lack lateral petiolar setae, though these may have been lost during preparation, which included critical-point drying. The three Tasmanian males also have somewhat shorter submarginal and postmarginal

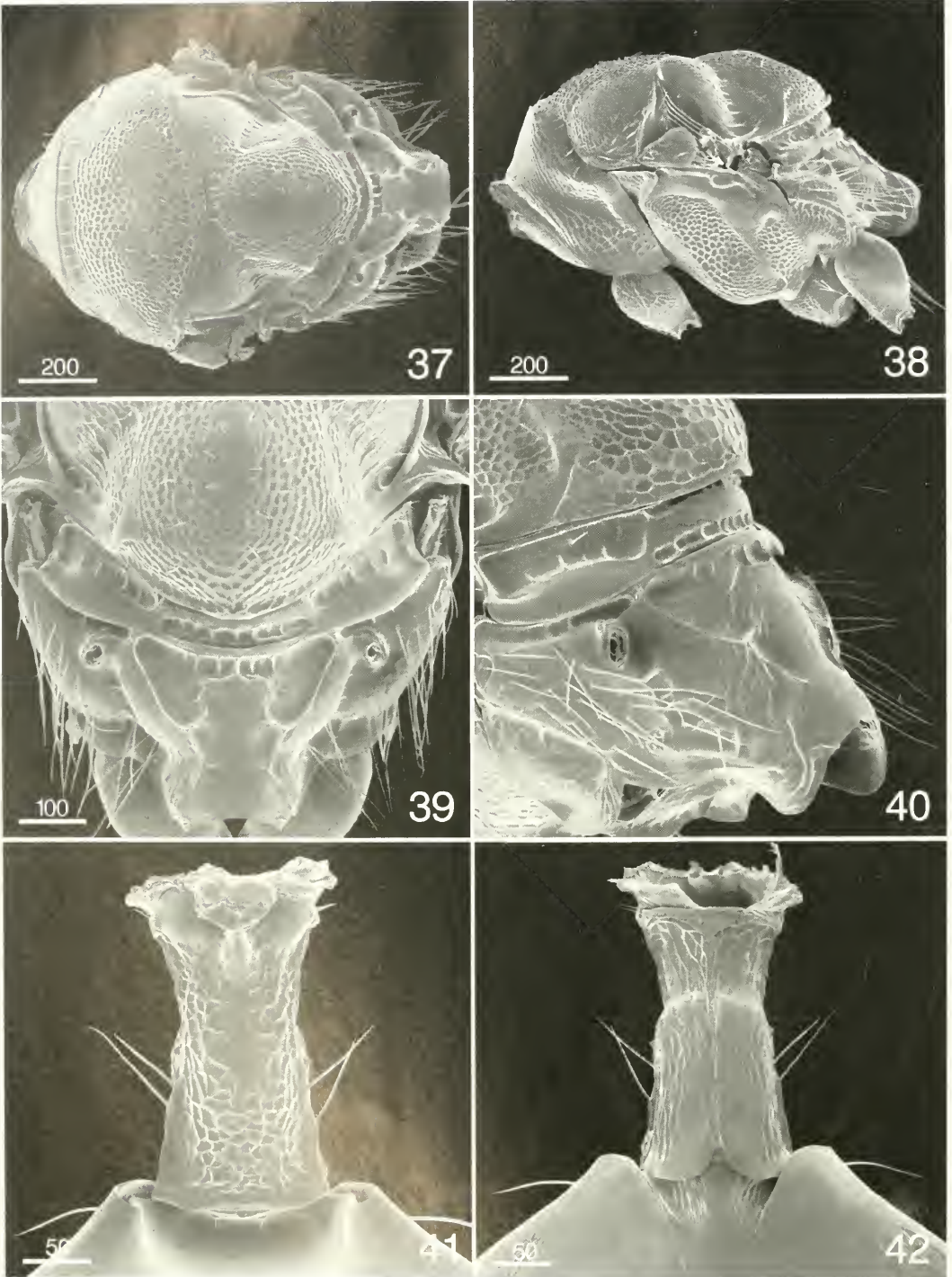

Figs. 37–42. *Pachyneuron rieki*: 37, mesosoma, dorsal ( $\text{♀}$ ); 38, mesosoma, lateral ( $\text{♀}$ ); 39, scutellum-propodeum ( $\text{♀}$ ); 40, apex of scutellum-propodeum, posterolateral ( $\text{♂}$ ); 41, petiole, dorsal ( $\text{♀}$ ); 42, petiole, ventral ( $\text{♀}$ ). Scale bars =  $\mu\text{m}$ .

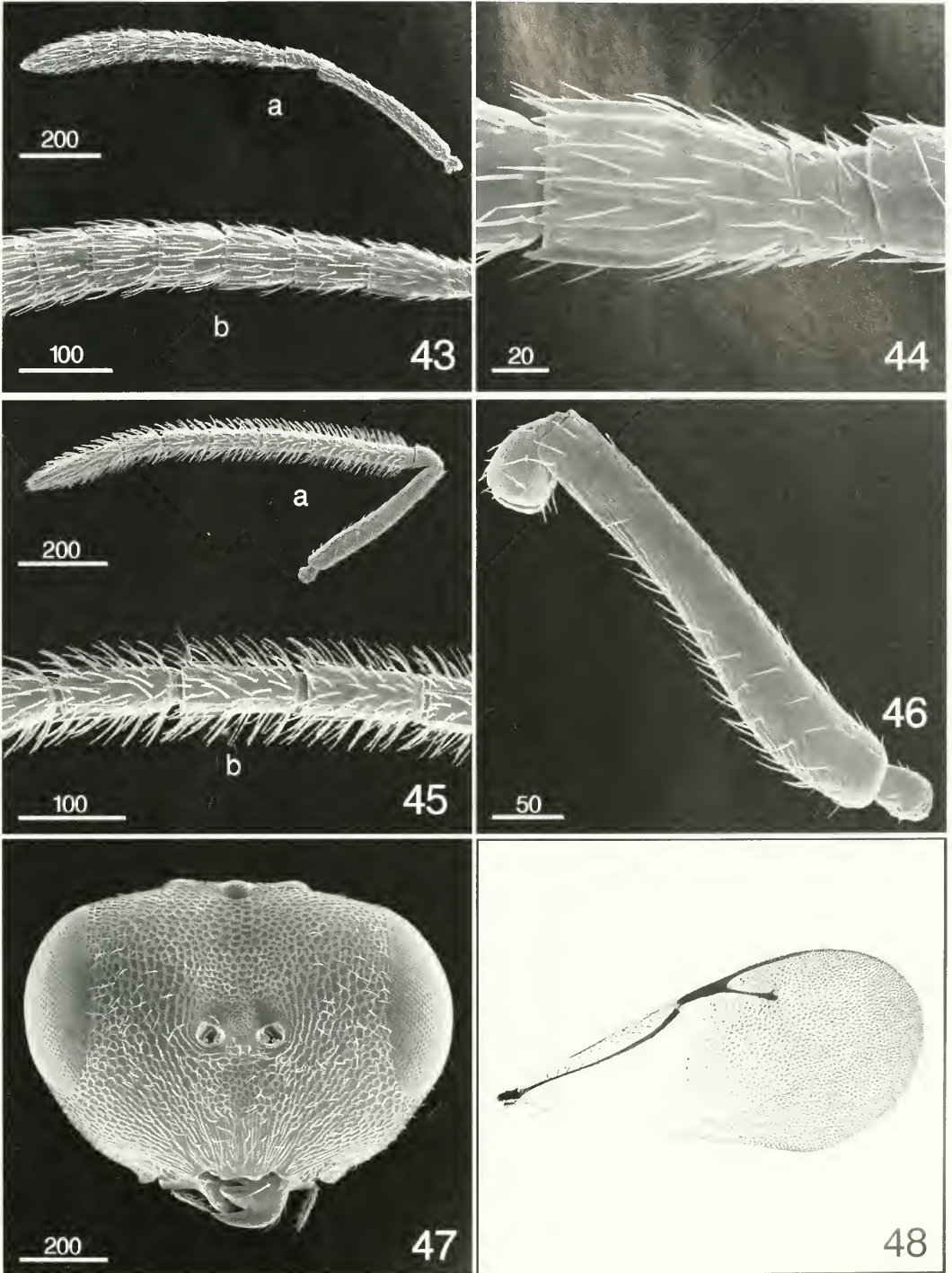

Figs. 43–48. *Pachyneuron ricki*: 43, antenna (♀); 43a, entire, 43b, anelli and funicular segments; 44, basal flagellar segments, fl<sub>1</sub>-fl<sub>3</sub> (♀); 45, antenna (♂); 45a, entire, 45b, middle funicular segments, fl<sub>5</sub>-fl<sub>7</sub>; 46, scape (♂); 47, head, frontal (♂); 48, forewing (♀). Scale bars =  $\mu\text{m}$ .

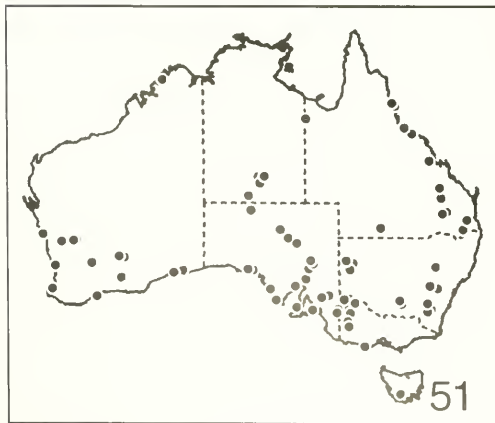
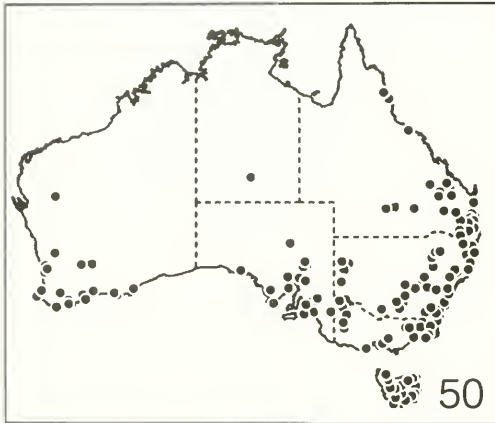
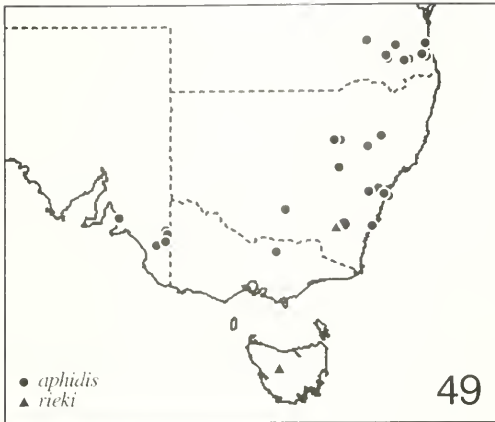

Fig. 49. Australian distribution: *Pachyneuron aphidis* (●), *P. rieki* (▲).

Fig. 50. Australian distribution, *Pachyneuron emersoni*.

Fig. 51. Australian distribution, *Pachyneuron nelsoni*.

veins than do the ACT males ( $smv/mv = 2.70-2.86$  vs.  $2.94-3.23$  and  $pmv/mv = 1.30-1.43$  vs.  $1.53-1.74$ ;  $n = 3$ ), whose venation is more similar to that of measured females. However, there are insufficient specimens of both sexes to accurately estimate true variability in any of the measured structures.

Graham (1969) differentiated *P. umbra-tum* Delucchi (subsequently synonymized with *P. groenlandicum* (Holmgren) by Hedqvist, 1977) from *P. formosum* based on the presence of 2–12 setae on the basal vein. Though this is similar to *P. rieki*, *P. groenlandicum* lacks the petiolar setae characteristic of *P. rieki* and has an evenly reticulate propodeum. An unidentified species from America north of Mexico has petiolar setae and often a setose basal vein similar to *P. rieki*, but differs in propodeal sculpture, having the plical region more or less evenly reticulate or with some irregular, oblique carinae similar to *P. albutius*.

## CONCLUSIONS

Without a world species revision it is premature to hypothesize about the phylogenetic relationships of the Australian fauna of *Pachyneuron*. However, *P. emersoni*, *P. nelsoni* and *P. rieki* all share a posteromedially differentiated propodeal plical region that is delineated by a more or less W-shaped complex of plicae and costulae (Figs. 15, 29, 39). This structure distinguishes the species from other morphologically similar species, such as *P. formosum* and *P. albutius* from the Nearctic and Palearctic regions, respectively, which have the propodeal plical region more or less uniformly reticulate. Although polarity is uncertain, the similar propodeal structure suggests that *P. emersoni*, *P. nelsoni* and *P. rieki* are closely related and may have speciated in Australia, which would not support the hypothesis that *P. nelsoni* was introduced into Australia recently (Bouček 1988). *Pachyneuron nelsoni* is also one of the most widely distributed species in Australia and the only species

yet recovered from northern Western Australia. (Fig. 51). The distribution pattern does not suggest a recent introduction. *Pachyneuron aphidis* is certainly much more distantly related to the other species and undoubtedly represents a separate introduction into Australia, probably accidentally by man into New South Wales based on present distribution (Fig. 49) and the earliest collection records.

### ACKNOWLEDGMENTS

This study was conducted primarily during a work transfer to the Australian National Insect Collection (CSIRO, Canberra), and I gratefully acknowledge their assistance and the use of their collection and facilities. The individuals and institutions listed under material and methods are thanked for the loan of material on which the study was based. Ms. J. Read (ECORC) generated all the illustrations, including dissecting and preparing the specimens for SEM and photography, producing the images, and preparing the illustrative plates. Drs. John Huber and James O'Hara are gratefully acknowledged for critically reviewing the manuscript.

### LITERATURE CITED

- Agassiz, L. 1846. *Nomenclator Zoologicus, continens nomina systematica generum Animalium tam viventium quam fossilium*. Fasc. 9. Hymenoptera. Solothurn. 36 pp.
- Ashmead, W. H. 1886[36]. Studies on the North American Chalcididae, with descriptions of new species from Florida. (Paper no. 7). *Transactions of the Entomological Society of America* 13: 125–135.
- Ashmead, W. H. 1887[37]. Report on insects injurious to garden crops in Florida. *United States Department of Agriculture, Division of Entomology Bulletin* 14: 9–29.
- Ashmead, W. H. 1888. Entomological section. *Bulletin of the Florida Agricultural Experiment Station, Gainesville* 2: 12–27.
- Ashmead, W. H. 1904[243]. Descriptions of new Hymenoptera from Japan.—II. *Journal of the New York Entomological Society* 12(3): 146–165.
- Blanchard, M. E. 1840. *Histoire naturelle des Insectes*. III. Paris. 672 pp. + 155 pls.
- Bolte, K. B. 1996. Techniques for obtaining scanning electron micrographs of minute arthropods. *Proceedings of the Entomological Society of Ontario* 127: 67–87.
- Bouček, Z. 1965. A review of the chalcidoid fauna of the Moldavian S.S.R., with descriptions of new species (Hymenoptera). *Acta Faunistica Entomologica Musei Nationalis Pragae* 11(97): 5–37.
- Bouček, Z. 1977. A faunistic review of the Yugoslavian Chalcidoidea (parasitic Hymenoptera). *Acta entomologica Jugoslavica* 13, supplement: 1–145.
- Bouček, Z. 1988. *Australasian Chalcidoidea (Hymenoptera). A Biosystematic Revision of Genera of Fourteen Families, with a Reclassification of Species*. CAB International, Wallingford. 832 pp.
- Bouček, Z., B. R. Subba Rao, and S. I. Farooqi. 1978. A preliminary review of Pteromalidae (Hymenoptera) of India and adjacent countries. *Oriental Insects* 12(4): 433–468.
- Bouché, P. F. 1834. *Naturgeschichte der Insekten, besonders in hinsicht ihrer ersten Zustände als Larven und Puppen*. Berlin. v + 216 pp.
- Brèthes, J. 1913. Himenópteros de la América meridional. *Anales del Museo Nacional de Historia Natural de Buenos Aires* 24: 35–160.
- Crawford, J. C. 1908. The entomological writings of William Harris Ashmead, with an index to the new genera described by him. *Proceedings of the Entomological Society of Washington* 10: 131–155.
- Dahms, E. C. 1978. A checklist of the types of Australian Hymenoptera described by Alexandre Arsené Girault: I. Introduction, Acknowledgments, Biography and localities. *Memoirs of the Queensland Museum* 19: 127–190 + 15 pls.
- Dahms, E. C. 1983. A checklist of the types of Australian Hymenoptera described by Alexandre Arsené Girault: II. Preamble and Chalcidoidea species A-E with advisory notes. *Memoirs of the Queensland Museum* 21(1): 1–255.
- Dahms, E. C. 1984. A checklist of the types of Australian Hymenoptera described by Alexandre Arsené Girault: III. Chalcidoidea species F-M with advisory notes. *Memoirs of the Queensland Museum* 21: 779–842.
- Dahms, E. C. 1986. A checklist of the types of Australian Hymenoptera described by Alexandre Arsené Girault: IV. Chalcidoidea species N-Z and genera with advisory notes plus addenda and corrigenda. *Memoirs of the Queensland Museum* 22: 319–739.
- Delucchi, V. 1956(1955). Beiträge zur Kenntnis der Pteromaliden (Hym., Chalcidoidea). *Zeitschrift für angewandte Entomologie* 38(2): 122–156.
- De Santis, L. 1957. Anotaciones sobre Calcidoideos Argentinos (Hymenoptera). *Notas del Museo de La Plata, Zoología* 19(173): 107–119.
- De Santis, L. 1975. Nota sobre calcidoideos neotropicos (Hymenoptera). *Neotropica* 21(64): 8–10.
- Doğanlar, M. 1986. Morphological studies of the hypopygium and its importance to the taxonomy of the genera *Pachyneuron* and *Emicura* (Hymenoptera: Pteromalidae), with description of a new species of *Pachyneuron* from Turkey. *Fen Bilimleri Dergisi*. 4: 23–32.
- Förster, A. 1841. *Beiträge zur monographie der Pteromalinen* Nees. 1 Heft. Aachen. 46 pp. + 1 pl.

- Gahan, A. B. 1918. *Propachyneuron* Girault (Hymenoptera, Chalcidoidea). *Proceedings of the Entomological Society of Washington* 20: 66.
- Gahan, A. B. 1924(1923). Types of two chalcid-flies misidentified. *Proceedings of the Entomological Society of Washington* 25(9): 185-188.
- Gibson, G. A. P. 1997. Chapter 2. Morphology and Terminology. Pages 16-44 in Gibson, G. A. P., J. T. Huber, and J. B. Woolley (eds). *Annotated Keys to the Genera of Nearctic Chalcidoidea (Hymenoptera)*. National Research Council Canada, Research Press, Ottawa. 794 pp.
- Girault, A. A. 1916[274]. Australian Hymenoptera Chalcidoidea. General supplement. *Memoirs of the Queensland Museum* 5: 205-230.
- Girault, A. A. 1917[322]. The North American species of *Pachyneuron* with three new species (chalcid-flies). *Psyche* 24: 88-90.
- Girault, A. A. 1917[327]. A new genus or subgenus of pachyneurine chalcid-flies. *Psyche* 24: 102.
- Girault, A. A. 1917[330]. *Descriptions Hymenopterorum Chalcidoidearum variorum cum observationibus* V. Private publication, Glendale. 16 pp.
- Girault, A. A. 1927[416]. Notes on and descriptions of chalcid wasps (Chalcididae) in the South Australian Museum. *Records of the South Australian Museum* 3: 309-338.
- Girault, A. A. 1928[421]. *A prodigious discourse on wild animals*. Private publication, Brisbane. 3 pp.
- Girault, A. A. 1929[431]. Notes on, and descriptions of, chalcid wasps in the South Australian Museum. Concluding paper. *Transactions and Proceedings of the Royal Society of South Australia* 53: 309-346.
- Graham, M. W. R. de V. 1969. The Pteromalidae of North-Western Europe (Hymenoptera: Chalcidoidea). *Bulletin of the British Museum (Natural History), Entomology Supplement* 16: 1-908.
- Hedqvist, K.-J. 1977. Notes on Chalcidoidea XI (Hymenoptera). A new species of *Habrocytus* Thomson from Sweden and a lectotype selection for *Pteromalus groenlandicus* Holmgren. *Entomologica Scandinavica* 8: 237-238.
- Howard, L. O. 1890. Some new parasites of the grain plant louse. *Insect Life* 2: 246-248.
- Howard, L. O. 1891. The habits of *Pachyneuron*. *Proceedings of the Entomological Society of Washington* 2: 105-109.
- Huang, D. and D. Liao. 1987. A new species of *Pachyneuron* (Hymenoptera: Chalcidoidea: Pteromalidae). *Entomotaxonomia* 10(1-2): 19-21.
- Kamijo, K. and H. Takada. 1973. Studies on aphid hyperparasites of Japan, II. Aphid hyperparasites of the Pteromalidae occurring in Japan (Hymenoptera). *Insecta Matsumurana, n.s.* 2: 39-76.
- Leiboff, R. O. 1948. Aparición de un parásito poco frecuente del pulgón verde de los cereales en la Pampa Central. *Revista Argentina de Agronomía* 15(4): 256-257.
- Mani, M. S. 1939. Descriptions of new and records of some known chalcidoid and other hymenopterous parasites from India. *Indian Journal of Entomology* 1: 69-99.
- Mani, M. S. and G. G. Saraswat. 1974. Part III. Pages 85-107 in: Mani, M. S., O. P. Dubey, B. K. Kaul, and G. G. Saraswat. Descriptions of some new and new records of some known Chalcidoidea (Hymenoptera) from India. *Memoirs of the School of Entomology, St. Johns's College*, no. 3. 377 pp.
- Masi, L. 1929. Risultati zoologici della Missione inviata dalla R. Società Geografica Italiana per l'esplorazione dell'Oasi di Giarabub (1926-1927). Hymenoptera Chalcididae. *Annali del Museo Civico di Storia Naturale Giacomo Doria, Genova* 53: 195-240.
- Noyes, J. S. 1998. *Catalogue of the Chalcidoidea of the World*. CD-Rom. Amsterdam, The Netherlands: Expert Center for Taxonomic Information.
- Reinhard, H. 1859. Die Batfläusen lebenden Pteromalinen. *Stettiner Entomologische Zeitung* 20: 191-197.
- Szelényi, G. 1942. Über die Chalcididen-Gattung *Pachyneuron* Walk. (Hymen.). *Zentralblatt für das gesamte Forstwesen* 68: 93-105.
- Timberlake, P. H. 1918. Notes on some of the immigrant parasitic Hymenoptera of the Hawaiian Islands. *Proceedings of the Hawaiian Entomological Society* 3(5): 399-404.
- Timberlake, P. H. 1926. New species of Hawaiian chalcid-flies (Hymenoptera). *Proceedings of the Hawaiian Entomological Society* 6(2): 305-321.
- Walker, F. 1833. Monographia Chalcidum. *Entomological Magazine* 1: 367-384.
- Walker, F. 1843. Description des Chalcidites trouvées au Bluff de Saint-Jean, dans la Floride orientale, par MM.E. Doubleday et R. Foerster. *Annales de la Société Entomologique de France* (2) 1: 145-162.
- Walker, F. 1850. Notes on Chalcidites, and descriptions of various new species. *Annals and Magazine of Natural History* (2) 5: 125-133.

## New Descriptions of *Halictus (Seladonia)* from the New World (Hymenoptera: Halictidae)

JESSICA JANJIC AND LAURENCE PACKER

Department of Biology, York University, 4700 Keele St., Toronto, Ontario, Canada, M3J 1P3

---

*Abstract.*—We describe females of *Halictus (Seladonia) pinguismentus* Janjic and Packer *new species* from Guadeloupe Island, Mexico and provide the first descriptions of the male and putative queen of *H. (S.) harmonius* Sandhouse and the male and worker of *H. (S.) lanei* (Moure). Additionally, we describe the second known putative queen specimen of *H. (S.) lanei* and describe the huge morphological differences between the castes in this species. Differences among these species are discussed with respect to other New World members of the subgenus.

---

In order to facilitate the preparation of a phylogenetic analysis of bees of the subgenus *Seladonia* (genus *Halictus*) with particular emphasis on the New World species, we present additional descriptions of bees in this group. North American species of the genus *Halictus* were treated by Sandhouse (1941) and Central and South American *Seladonia* by Wille and Michener (1971). Hitherto, seven New World *Seladonia* species have been recognized (Moure and Hurd 1987): *H. (S.) confusus* Smith, a holarctic species found throughout North America and Europe; *H. (S.) harmonius* Sandhouse, apparently restricted to southern California; *H. (S.) hesperus* Smith, which is primarily a central American species, found from Mexico to Colombia; *H. (S.) lanei* (Moure), which has been recorded from Brazil but which seems to extend into Venezuela and Colombia; *H. (S.) lutescens* Friese, which is found approximately sympatrically with *H. hesperus*; *H. (S.) tripartitus* Cockerell, found in the western USA and northwestern Mexico; and *H. (S.) virgatellus* Cockerell, restricted to areas around and above the treeline in western North America from the North West Territories of Canada to New Mexico.

As a result of our studies we have

found specimens of an additional species collected from the island of Guadeloupe off the west coast of Baja California. We describe this new species below. We also present the first descriptions of the males of *H. (S.) harmonius* and *H. (S.) lanei*. Most of the aforementioned species of *Seladonia* are known to be social and at least *H. hesperus* has large morphological caste differences (Brooks and Roubik 1983; Packer 1985) such that the castes would not readily be recognized as being conspecific. The description of *H. harmonius* was apparently based upon worker females (some observations on sociality in this species will be published elsewhere) and that of *H. lanei* appears, based upon macrocephaly, to be that of a queen. Here we provide the first detailed descriptions of an apparent queen of *H. harmonius* and worker of *H. lanei*. Lastly, as the original description of *H. lanei* was short and in Portuguese (Moure 1940), we provide an additional description of a queen of this rare species, a specimen which is larger and even more macrocephalic than the type.

We are not undertaking a complete revision of the New World members of the subgenus *Seladonia* as this is beyond our scope at this time. In particular, detailed studies of the widespread and variable *H.*

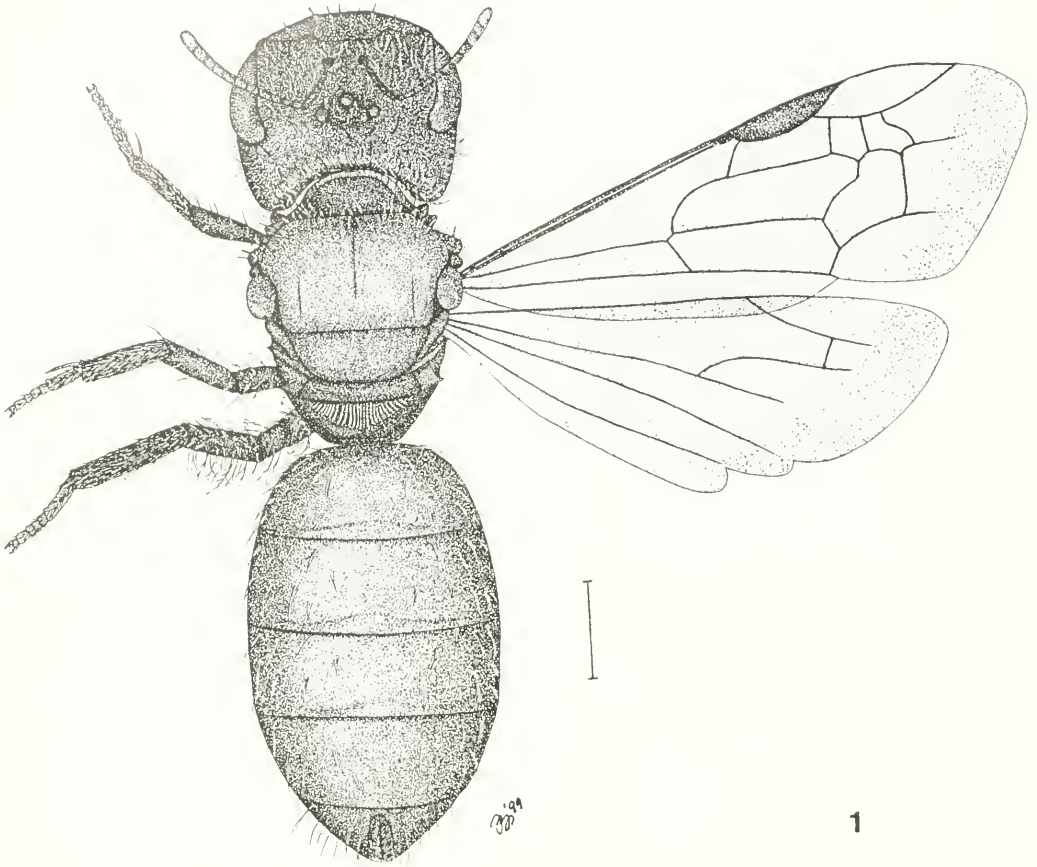

Fig. 1. *Halictus pinguismentus* Janjic and Packer, habitus, largest paratype female. Scale bar = 1mm.

(*S.*) *confusus* are badly needed and should be performed in conjunction with genetic studies (Rosenmeier and Packer 1993; Taylor and Packer 1997). The North American *Seladonia* species were keyed and briefly described by Sandhouse (1941) and the Central American species-pair *H. hesperus* and *H. lutescens* were treated in detail by Wille and Michener (1971).

#### MATERIALS AND METHODS

External morphology is described from pinned specimens. Genitalia from male *H. harmonius* and *H. lanei* and the labra of all castes/species were removed and treated in 5% potassium hydroxide before being stored in glycerine. Details of surface sculpture were observed with light reflected from the light source (a Schott KL 1500-

Z fibre optic system) using a variety of white surfaces, this was found more convenient than using light transmitted through semi-opaque paper. Terminology generally follows that of Eickwort (1969), however, for the labrum we use the terminology of Walker (1995) and for surface sculpture characteristics we refer to McGinley (1986). Measurements were made using a Leica MS5 microscope with an ocular micrometer. When more than one individual was available to us we present measurements for the type followed by the range in brackets.

We often refer to lengths of particular structures or of pilosity with reference to the diameter of the median ocellus "od" of the same individual. The relative size and density of punctures are given in

terms of the relationship between puncture diameter and the interspaces between them such as " $i = 2d$ ". Other acronyms used are as follows: for metasomal terga and sterna we use T and S respectively (as the first abdominal segment is the mesosomal propodeum this means that T3 represents the third metasomal tergum but the fourth abdominal tergum), A1 refers to the first annulus of the antenna (ie following the pedicel), UID and LID refer to the upper and lower interorbital distances respectively, IOD is the interocellar distance—the distance between the inner margins of the lateral ocelli and OOD is the ocell-ocular distance, the shortest distance between the outer margin of one lateral ocellus and the ipsilateral compound eye.

In the descriptions below, we concentrate on those features which vary among the New World species of *Seladonia* and do not repeat aspects which are constant, or almost so, among all 8 species. Character states which are diagnostic for a species are italicized.

*Halictus (Seladonia) pinguismentus*

Janjic and Packer, new species

(Figs. 1–8)

*Holotype female*.—**Size:** Total body length 7mm (7–8.3mm), head width 2.1mm (2.1–2.4mm), forewing length 5.3mm (5.3–5.7mm). **Coloration:** Head brown with dark metallic blue reflections except for clypeus, supraclypeal area, and epistomal and hypostomal regions non-metallic, red-brown; mesosoma brown with dull metallic green reflections except disk of scutum with bronze-metallic reflections, scutellum and metanotum dark brown, and legs amber but with tibiae slightly darker; metasoma orange-brown with apical impressed areas translucent testaceous; general body surface quite shiny especially on lower face, disk of scutum and scutellum. **Pubescence:** Off-white, moderately long (1.5–2od), pale orange recumbent hairs 0.5 od long mixed

with longer hairs on scutum. **Structure:** *Head* (Figs. 1–2): Slightly broader than long (1:0.9); round in anterior view but with vertex flat. Labrum (Figs. 4, 5) with basal box comparatively long, length to width 1:1.6, *apico-medially produced into an obtuse angle*; elevated median area U-shaped; distal process narrow,  $\frac{2}{5}$ <sup>th</sup> as wide at base as width of basal box, triangular; apical keel very broad basally, 0.7 times as wide at base as width of distal process at that point, gradually tapering to apex in dorsal view; keel flat on top, largely semi-circular in profile, elongate beyond ventral margin of distal process for almost half of its length and with this produced portion weakly concave ventrally. Mandible (Fig. 7) long, reaching base of opposing mandible, *subapical tooth with dorsal margin concave, thus appearing unusually small at apex and expanded basally*. Clypeus wide, 3 times wider than long, evenly convex, punctures uniformly sparse ( $i \geq 2od$ ). Supraclypeal area with apical margin gently convex, punctures of two distinct sizes, apically sparser than on clypeus, basally more dense than on clypeus. Malar space extremely short, approximately as long as diameter of ommatidium of compound eye. Interocular area with punctures almost contiguous medially, less crowded ( $i = d$ ) laterally and below antennal base. Frontal carina extending from just below antennal bases to less than half distance from its apex to the median ocellus. Eyes converging above, UOD: LID 1:0.9. Vertex flat and long, 2.5od, area between lateral ocelli slightly raised, IOD = 2od, area between lateral ocelli and compound eyes flat, OOD = 3.75od; punctures behind ocelli crowded, on rest of vertex less dense,  $i \leq d$ . Gena long, gradually narrowing behind eyes in dorsal view, produced postero-ventrally to form right angle or produced as a rounded lobe; maximum width approximately twice maximum width of compound eye in lateral view, excluding lobe if present; punctures somewhat effaced in weak striae, striae becom-

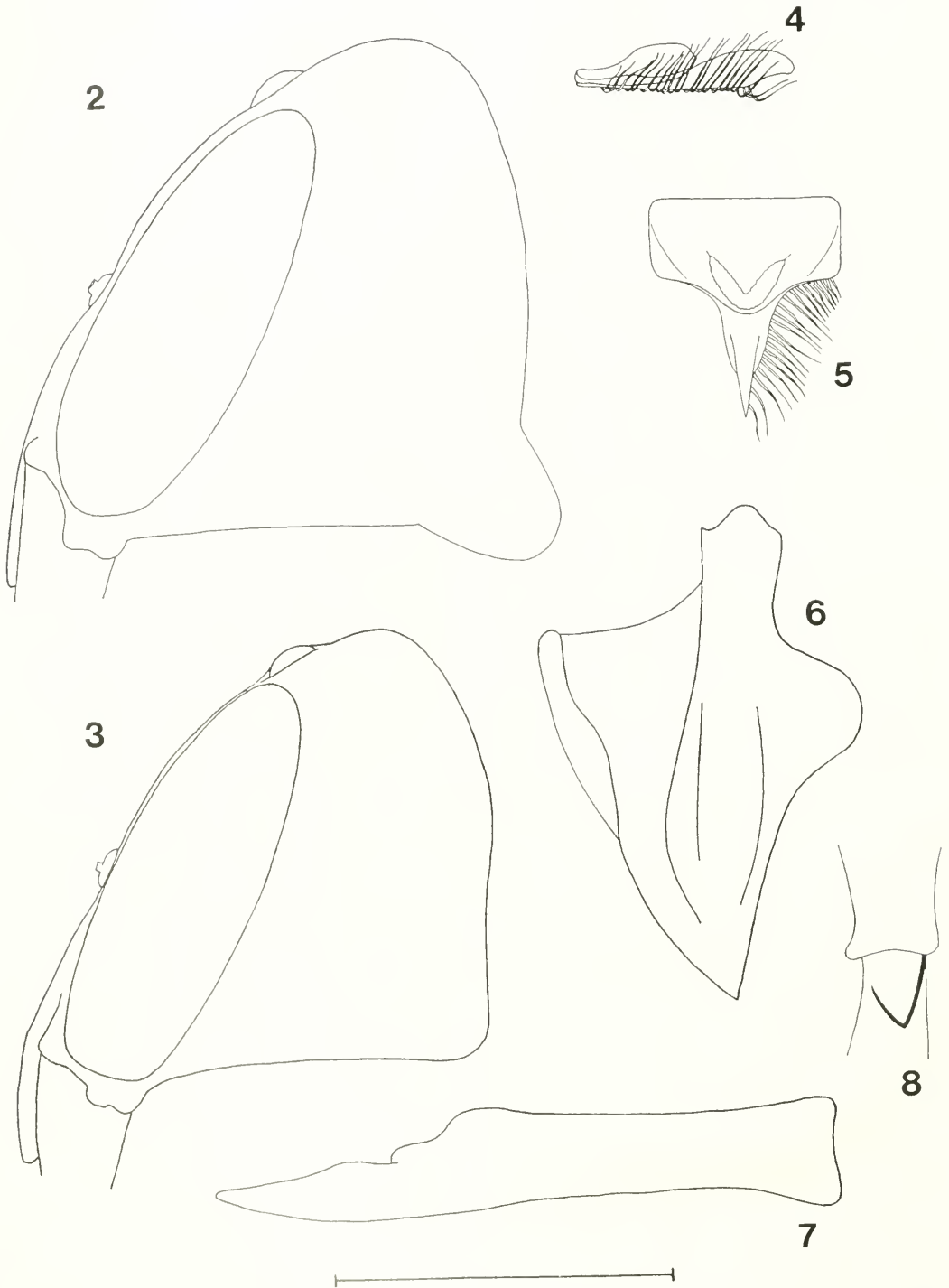

Figs. 2-8. *Halictus pinguismentus*. 2-3. Head, side view. 2, Largest paratype female. 3, Holotype female. 4-5. Labrum. 4, Lateral view. 5, Dorsal view. 6, Pronotum, side view, holotype. 7, Mandible. 8, Femur/tibial junction to show basitibial plate, not to scale. Scale bar = 1 mm.

ing stronger ventrally. Hypostomal region longitudinally weakly and finely striate, concave as a result of the genal angle. *Mesosoma*: Pronotum (Figs. 1 and 6) with lateral angle strongly produced, carinate anteriorly, carina continuous with pronotal lateral ridge which is strong, acute and entire; *lateral angle concave behind carina in dorsal view* and then swollen; lateral surface with one or two additional weak dorso-ventral carinulae; dorsal ridge not carinate. Scutum wider than long (1.2:1); anterior margin evenly convex in dorsal view, overhanging pronotum medially; median line weak, half length of scutum; parapsidal lines weak, extending  $\frac{2}{3}$  length of scutum; punctuation uniformly deep and density,  $i = 0.5-1d$ , moderate in size, becoming effaced along anterior margin of scutum. Scutellum  $\frac{5}{7}$  as long as scutum; punctures sparser ( $i \geq 2d$ ), shallower and smaller than on scutum. Metanotum half as long as scutellum; punctures fine, dense ( $i = d$ ), becoming transversely effaced laterally. Mesepisternum dorso-ventrally striate, striations deep and coarse; hypopimeral area with striations primarily longitudinal. Metepisternum with striae which are so deep and coarse as to appear more like ridges, primarily directed longitudinally. Propodeal dorsal surface intermediate in length between scutellum and metanotum; posterior surface carinate to  $\frac{3}{4}$  height, sparsely and minutely punctate; dorsal surface with approximately 30 longitudinal striae; fine, moderately dense punctures at postero-lateral corners; lateral surface with dorso-ventrally directed, weak striae, these absent on anterior portion which has small, dense ( $i = d$ ) but shallow punctures. Tegula orange-brown, shining; with very fine, shallow punctures anteriorly. *Wings*: Veins translucent amber and wing membrane hyaline as usual in *Seladonia*. *Legs*: Hindleg with basitibial plate elongate triangular, 2od in length, entire (anterior and posterior margins well defined) and acutely pointed (Fig. 8); inner hind tibial spur with 3 or 4 teeth (not

including apex), the first longer than wide, the remainder shorter than basal width. *Metasoma*: T1 length to width ratio 0.7:1; length of apical impressed area 3od medially and 2od laterally; anterior surface shining, sparsely punctured ( $i \geq 3d$ ), without background microsculpture; becoming weakly, transversely microreticulate at brow with punctures minute and dense, especially laterally ( $i \geq d$ ); microreticulations absent on disk and punctures increasingly larger and denser ( $i = d$ ) posteriorly, sparser on lateral swellings; apical impressed region with fine, irregular punctures. T2 minutely roughened anteriorly, disk with shallow, dense punctures ( $i = d$ ), apical impression long, 4od, punctures as described for T1. Punctures increasingly small and effaced on successive terga, apical impressions of T3 and T4 long, 4od. Apical hair bands weakly developed, not extending ventrally.

*Male*.—Unknown.

*Etymology*.—The specific epithet literally means "fat chin", referring to the expanded genal region of this species, especially in larger specimens.

*Specimens examined*.—The holotype female is missing both antennae, the left mid leg beyond the coxa, and the left hind leg beyond the trochanter. The specimen appears to have become slightly worn and somewhat faded. In addition to the holotype, we designate three paratypes, two of which are significantly larger (see below). The holotype and one paratype are labeled "Guadeloupe Island, Pac. Ocean" (the other two paratypes are labeled "Guadeloupe Island P.O."), without date or name of collector. Each specimen bears a second reddish brown label that has "Ent. Soc." typed upon it and all four specimens were originally from the Philadelphia Academy of Sciences Collection where all but one are now housed (one remains in the Packer collection at York University). The two large paratypes have several marked differences from the two smaller individuals reminiscent of caste

differences found in some of the other New World *Seladonia* species. We describe the most important differences below.

*Discussion.*—Based upon the appearance of the specimens and the labels associated with them, they would appear to be quite ancient. The locality is an island off the west coast of Baja California. It is currently uninhabited, has been ecologically damaged by goats, and is difficult to access owing to steep cliffs on all sides.

The larger individuals have slight bronze reflections on the gena and scutellum. The gena is produced into a rounded lobe postero-ventrally (Fig. 2), this lobe is 2.5od long and 3od wide at its base and it renders the ventral margin of the gena concave. The pronotal lateral angle is even more strongly developed than in the holotype. Additionally, the larger bees have 4 teeth on the inner hind tibial spur, as opposed to the 3 in the holotype. One of the larger specimens has much of its surface covered in an amber coloured material which may be dried nectar, it also has much of the pubescence worn away although its wings are not nicked, suggesting that it was not an old individual but rather one that had been badly treated following capture. The other large paratype is in good condition, although it is missing apical tarsal segments of both hind legs and the left mid leg. The single small paratype has had its head and thorax partially crushed.

We have not been able to locate any additional specimens of this species. In fact, we have not been able to find any additional collections of bees from the type locality.

*Halictus (Seladonia) harmonius*  
Sandhouse  
(Figs. 10–16)

*Halictus (Halictus) harmonius* Sandhouse 1941:  
36, female (USNM).

*Male.*—**Size:** Very small, total length 4–5mm, head width 1.05–1.2mm, forewing

length 2.8–3mm. **Coloration:** Head metallic bluish-green except for clypeus, antennae and hypostoma; clypeus dark brown with apical  $\frac{1}{5}$ <sup>th</sup> often yellow; antennae reddish-brown with scape and pedicel darker and anterior surface of flagellum slightly paler than remainder, anterior surface of first annulus yellowish; hypostoma brown; mesosoma metallic bluish-green except for reddish brown venter and legs; legs with narrow basal and apical bands on tibiae and stripe of varying width on outer surface of fore tibia, this and mid and hind tarsi pale brown. **Pubescence:** White, mostly of moderate length, approximately 1od; longer (1.5–2od) on face, gena, anterior of scutum, on scutellum and metanotum, laterally on T5, and apical half of T6; short (0.5od) scale-like pubescence on side of face, sparse on gena and on apical impressions of abdominal terga. **Structure** (Fig 14.): *Head:* As wide as long but appearing longer due to narrowing of clypeus and of vertex behind compound eyes. Labrum wider than long (2.6:1). Malar area very short, less than 0.2od. Clypeus 1.3 times as wide as long; apical  $\frac{2}{3}$  projecting below a lower tangent of compound eye; punctures shallow and sparse,  $i = 3d$ . Supraclypeal area with punctures deeper and denser than clypeus,  $i = 2d$ . Gena and vertex unmodified. Antenna long, reaching past base of metasoma; scape short, twice apical width and no longer than medial flagellar annuli; pedicel shorter than wide; A1 less than half length of succeeding annuli, length and width subequal; remaining annuli twice as long as wide or longer. *Mesosoma:* Pronotum with lateral ridge weakly carinate; pronotal angle obtuse; dorso-ventral carina undefined. Scutum length and width subequal; convex anteriorly, slightly overhanging pronotum medially; median furrow weak but faintly discernible for entire length of scutum; parapsidal lines distinct, extending anteriorly for  $\frac{2}{3}$  length of scutum; punctuation deep, distinct and uniformly dense with interspaces approxi-

mately equal to puncture diameters. Scutellum slightly shorter than 1/2 scutal length; median line defined on anterior half; punctures uniform as on scutum. Metanotum half length of scutellum; raised medially; punctures dense to rugose medially, sparse but well defined laterally. Mesepisternum minutely roughened, punctures effaced. Metepisternum with uneven longitudinal striae. Propodeal dorsal surface intermediate in length between scutellum and metanotum, 2od long; rounded posteriorly in dorsal view; posterior carinae undefined; dorsal surface longitudinally ruguloso-striate, striations not reaching posterior margin and finely rugose apico-medially; posterior margin shining and devoid of sculpture; lateral and posterior surfaces with fine punctures  $i \geq d$  laterally, sparser on shinier background posteriorly. *Wings*: Veins dark amber, membrane hyaline. *Metasoma*: Terga slightly sinuate in lateral view (especially for T2 and T3), weakly depressed apically then gently convex to short (1od) apical impressed areas. T1 length subequal to width; basal area impunctate and shining; punctures deep, fine and dense ( $i = 1-2d$ ) elsewhere; punctures increasingly fine and sparse on succeeding terga, apical impressed areas impunctate and shining beneath hair bands. Sterna with short, dense pubescence. Apical margin of S4 broadly concave, with apically directed tuft of hairs on lateral 1/4 of posterior margin, these hairs twice as long as elsewhere, hairs medial to these tufts laterally directed, short and dense. Apical margin of S5 almost straight, with marginal row of sparse, posteriorly directed hairs, increasing in length from centre to lateral margins of segment. S6 with faint medial, basal depression. *Terminalia* (Figs. 15, 16): S7 triangular with pointed apex. S8 rounded. Gonobase with dorso-median suture distinct; ventro-lateral margins converging posteriorly to very acute lateral projections, no medio-dorsal cleft to apical margin, dorsally convex in lateral view; gon-

ocoxae elongate, sides subparallel with no marked concavities, strongly reflexed inner dorsal basal margin, lacking striation. *Gonostylus enormous, swollen, almost as long as gonocoxae, with ventral margin broadly rounded and becoming vertical apically, with apical lobe glabrous and quadrate both from above and in profile, with medial semicircular concavity half way along length just ventral to inner setose lobe. Second gonostylus half as long as apical gonostylus, parallel sided.*

*Putative Queen*.—**Size**: Small, body length 4.3mm, head width 1.3mm, forewing 3mm. **Coloration**: Head metallic green with bronze reflections; clypeus and epistomal region dark red-brown; gena and hypostomal area brown with greenish-bronze reflections; scutum and scutellum metallic green; metanotum dark brown with weak green reflections; pleura and propodeum metallic blue-green; area between fore and mid coxae orange-brown; legs brown, tibiae with pale basal spots; tegula amber; antennae brown, paler on anterior surface and at apex; metasoma brown; entire body except pleura, propodeum, and metasoma strongly shining owing to absence of microsculpture. **Pubescence**: Sparse, fine, and long (1.5–2od) on clypeus, anterolaterally on scutum, laterally on scutellum and metanotum, on pleura, dorsally on lateral surfaces of propodeum and laterally on metasomal terga, more abundant on T5 and covering T6; short (0.5od) and appressed near compound eyes on frons and gena, on pronotal angles, and metanotum; apical tergal hair bands weak and extending ventrally. **Structure**: *Head* (Fig. 12): quadrate, very slightly longer than wide 1.03:1, vertex slightly swollen behind compound eyes. *Labrum* (Fig. 10) with basal box twice as wide as long, apical margin convex; glandular area less than half width of basal box, not strongly protuberant, with basal portion lacking glandular openings medially to give whole area a flattened U-shape; distal process an equilateral triangle with 17 lateral setae,

somewhat sparser on apical half; apical keel long, extending  $\frac{1}{3}$  of its length beyond apical margin of distal process, slightly concave ventrally, rounded apically and somewhat unevenly convex dorsally in lateral view, dorsal surface narrow and flat. Clypeus weakly produced medially, lateral teeth obtuse; length to width 1:3.5; punctures small, shallow and unevenly sparse,  $i = 1-5d$ . Supraclypeal area weakly convex apically, punctures as on clypeus but somewhat more dense basally and laterally,  $i = 1-4d$ ; epistomal lobe very obtuse with subantennal sutures gradually curving into fronto-clypeal suture. Eyes converging slightly above (UID: LID = 0.95:1). Malar space very short, 0.25od. Frons with punctures small, dense and well defined throughout,  $i = d$ , except sparser below antennae ( $i = 1.5-2d$ ) and with impunctate area immediately above antennal bases; frontal suture short, extending from mid-level of toruli to less than half distance to median ocellus. Vertex slightly elongate, 2.5 od from lateral ocelli to posterior margin; IOD slightly less than 3od; OOD 3.5od; punctures effaced behind ocelli. Gena convex without angular projections, greatest width to eye width ratio slightly less than 2:1; punctures distinct immediately behind compound eye ( $i = d$ ); effaced elsewhere, weakly microstriate ventrally; hypostoma broadly convex, without angles or projections. Mandible (Fig. 11) swollen basally with well defined subapical tooth. *Mesosoma*: Pronotum overhung by scutum medially; lateral angle obtuse, dorso-ventral ridge undefined; lateral carina weak to pronotal lobe, collar weakly wrinkled. Scutum longer than wide (1.17:1); anterior margin straight between pronotal angles; median suture broad, extending half

length of scutum; parapsidial lines weak, extending to anterior  $\frac{1}{3}$  of scutum; punctures fine, moderately deep and uniformly dense ( $i = d$ ), but slightly more dense laterad to parapsidial lines and effaced along anterior margin. Scutellum weakly impressed medially; punctuation as on scutum. Metanotum half length of scutellum; punctures minute, dense ( $i = d$ ) medially becoming sparser and effaced laterally. Mesepisternum with large, shallow, sparse ( $i = 2d$ ) punctures partly effaced in roughened background. Metepisternum with antero-posteriorly oriented roughening. Propodeum with dorsal face as long as scutellum, posterior margin rounded; weakly and irregularly striate on dorsal surface except rugulose medially; lateral surfaces microreticulate, anteriorly with weak antero-posteriorly directed striae; posterior carinae not developed. *Legs*: Inner hind tibial spur with 3 teeth, the first longer than basal breadth, the other two broader than long. Basitibial plate entire, acutely pointed, narrow and long (1.7od). *Wings*: Veins pale honey coloured, costa and prestigma darker, membrane hyaline. *Mesosoma*: T1 length:width 1:1.7; apical impressed area 1od long; anterior half transversely microreticulate; apical half with small, weak, and slightly transversely effaced punctures of uniform density ( $i = d$ ); apical impressions with exceedingly minute, sparse punctures. Punctuation increasingly weak on succeeding terga. Apical impressed area of T2 1od, of T3 and T4 longer, almost 2od. Weak apical hair bands extending ventrally, that of T1 broadly interrupted medially, that of T2 narrowly so.

*Specimens examined*.—We have seen males from San Timoteo Canyon, Riverside Co., California and Yucaipa, San Ber-

→

Figs. 9–14. *Halictus harmonius*. 9, Labrum, worker, side view. Lower scale bar, = 1 mm. 10, Labrum, putative queen, side view. 11, Mandible, queen. Scale bar = 0.1 mm. 12, Putative queen. Scale bar = 0.1 mm. 13, Worker. 14, Habitus, male. Lower scale bar, = 1 mm.

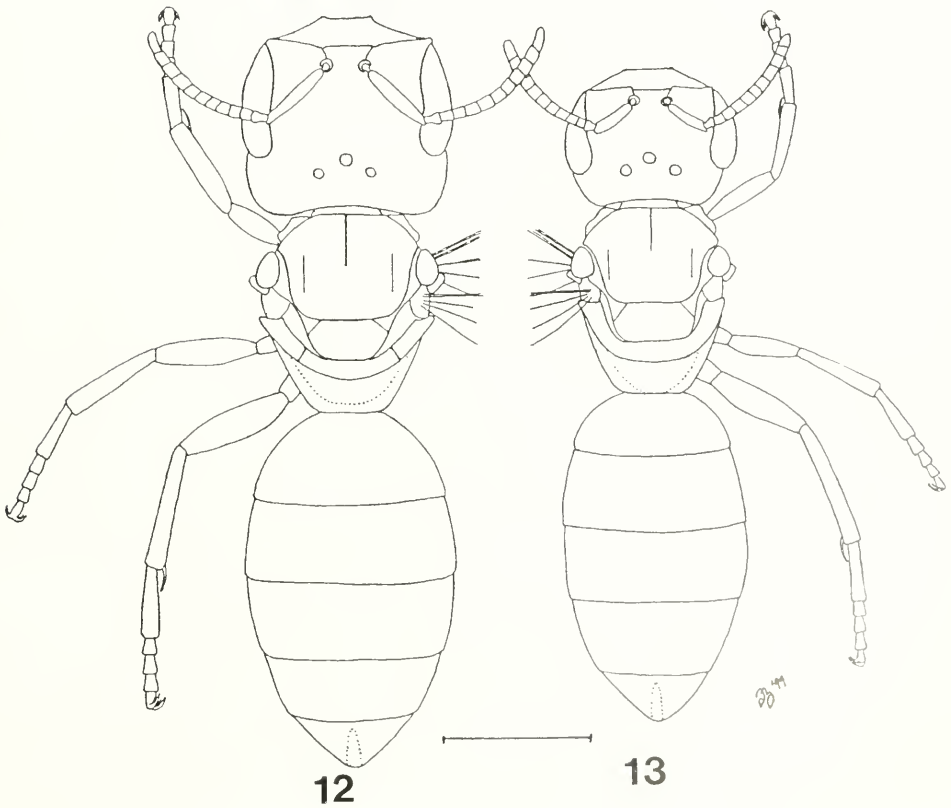
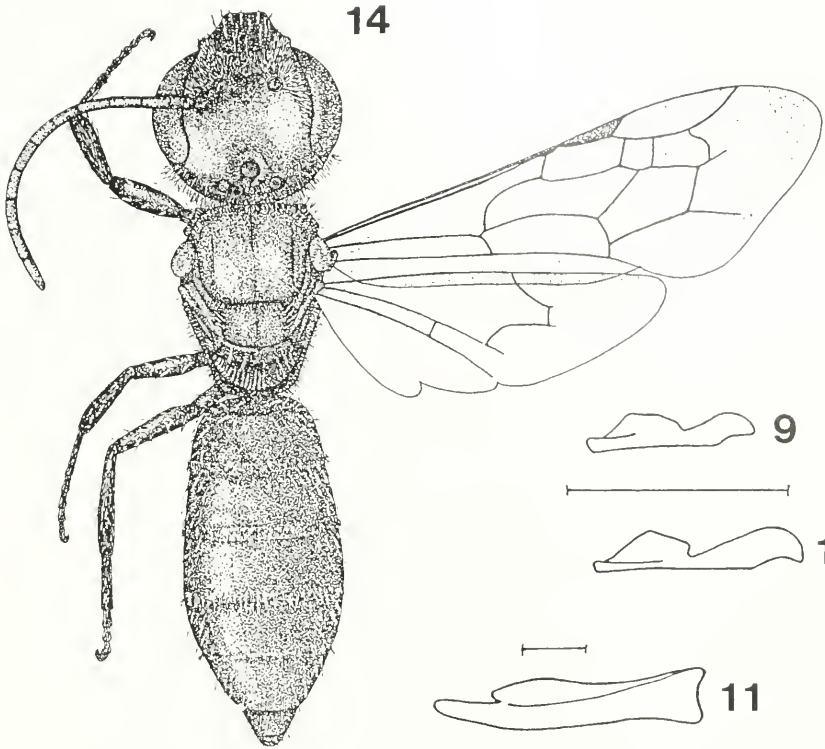

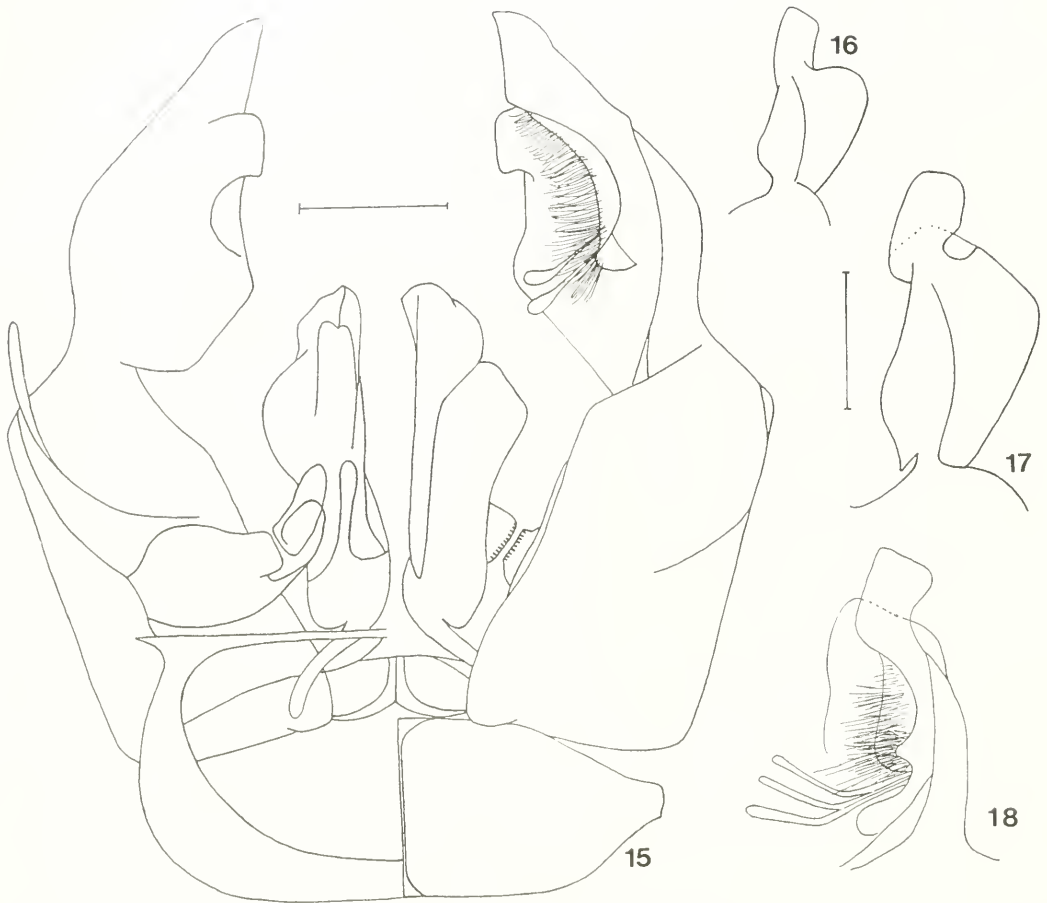

Figs. 15-18. *Halictus*, terminalia. 15-16. *Halictus harmonius*. 15, Genitalia, ventral view on left, dorsal on right. Scale bar = 0.1 mm. 16, Gonostylus, lateral view. 17-18. *Halictus tripartitus*. 17, Gonostylus, lateral view. 18, Gonostylus, ventral view. Scale bar = 0.25 mm.

nardino Co., California. The first specimen collected was found on August 12<sup>th</sup>, 1897 by H.A. Horn, and is deposited in the University of California, Riverside collection. Two additional males collected in the same canyon in 1974 were found in malaise traps run by M. Wasbauer and R. McMaster on Sept. 9<sup>th</sup>, these are in the Cornell University collection. The male from Yucaipa was collected by T. Griswold on June 9<sup>th</sup> 1975 and resides in the USDA collection at Logan, Utah. The queen specimen was collected at Wildwood Canyon, San Bernardino Co., California on May 22<sup>nd</sup>, 1977 by Terry Griswold who recognised the macrocephalic nature of the

specimen and labeled it as such. It resides in the USDA bee lab, Logan, Utah.

*Discussion.*—Males of *H. harmonius* vary in the extent of pale colouration on the legs and clypeus. Some specimens have the clypeus entirely dark and some have almost the entire surface of the fore tibiae pale in colour. All, however, have the mid and hind tibiae dark and concolorous with the corresponding femur.

Variation among the females would appear to result from features that probably relate to caste differences. The large putative queen specimen differs from the smaller workers that we have seen primarily in having a large, quadrate head

which is slightly longer than wide and eyes that are slightly divergent below (compare Figs. 12 and 13). In contrast, the worker head is slightly wider than long, more rounded and the eyes are slightly convergent below. The worker also has a more strongly produced clypeus; the widened lower portion of the face of the putative queen giving the clypeus a flatter aspect. The labra differ in that the queen has a longer and slightly differently shaped apical portion and a basal portion with a more abrupt apical margin than is found in the worker (compare Figs. 9 and 10 for worker and queen, respectively).

This species is most readily distinguished from other North American members of the subgenus by its extremely small size. Indeed, these bees are small even for *Lasioglossum* (*Dialictus*), from which they can be readily distinguished by the usual *Halictus* characters of strong apical wing veins and apical bands of pubescence on the abdominal terga (contrast figures 143 with 145 and 146 with 147 in Michener et al., 1994). Based upon genitalic characters (see below), this species is most closely related to *H. tripartitus*, from which it is readily distinguished on the basis of size (the smallest *H. tripartitus* are fully 50% larger than the largest *H. harmonius*) and the greater density of punctation of head, mesosoma and metasoma in the larger species. Additionally, fresh females of *H. tripartitus* have very well developed snowy-white apical tergal bands of pubescence whereas those of *H. harmonius* are sparser and on T1 are very broadly interrupted.

The genitalia of male *H. harmonius* are very distinctive and differ markedly from all other New World *Seladonia* except *H. tripartitus* (compare Figs. 15 and 16 with 18 and 17, respectively). Both species have large, swollen, sinuate gonostyli with a medial semicircular concavity and a thick, glabrous, apical lobe instead of a narrow, setose process. These gonostylus characters are shared by no other *Halictus* species

known to us. The two species differ in that *H. harmonius* has a proportionately much larger gonostylus—as long as the gonocoxae (Fig. 15), whereas this feature is only  $\frac{2}{3}$  as long as the gonocoxae in *H. tripartitus*. The shape of the apical lobe of the gonostylus also differs markedly between the species. In *H. harmonius* it is quadrate in profile (Fig. 16), whereas in *H. tripartitus* it is dorso-ventrally flattened (Fig. 17). The shape of the gonostylus just basal to the apical lobe is also different—in *H. harmonius* this area is angularly emarginate whereas in *H. tripartitus* there is a deep, sharp cleft that extends to the inner-basal margin of the lobe and the area basal to the lobe is expanded apically to form a short shelf beneath the apical lobe. The male of *H. tripartitus* also has paler legs and a head that is slightly wider than long, as opposed to round, and is not so markedly narrowed behind the compound eyes as in *H. harmonius*.

*Halictus harmonius* is a rare species having been found most often in the region around Yucaipa and the San Timoteo canyon in the San Bernardino/Riverside region of California. We have been unable to verify the records of this species listed in Krombein et al. (1979) from Colorado. We presume that their records were erroneous as this state was not included in the list of localities given by Moure and Hurd (1987).

#### *Halictus (Seladonia) lanei* (Moure)

(Figs 19–23, 26–29, 32–36)

*Pachycephala lanei* Moure 1940:55.

*Halictus (Seladonia) lanei* Michener 1954:38 (Moure Collection).

*Queen*.—Size: Total body length 9.5mm; head width 3.1mm, forewing length 6.8mm. **Coloration:** Head red-brown on clypeus, supra-clypeal area, genae, and hypostomal area, with bronze-green metallic reflections elsewhere; malar area and apex of mandible black; antennae light brown. Scutum and scutellum dark brown with

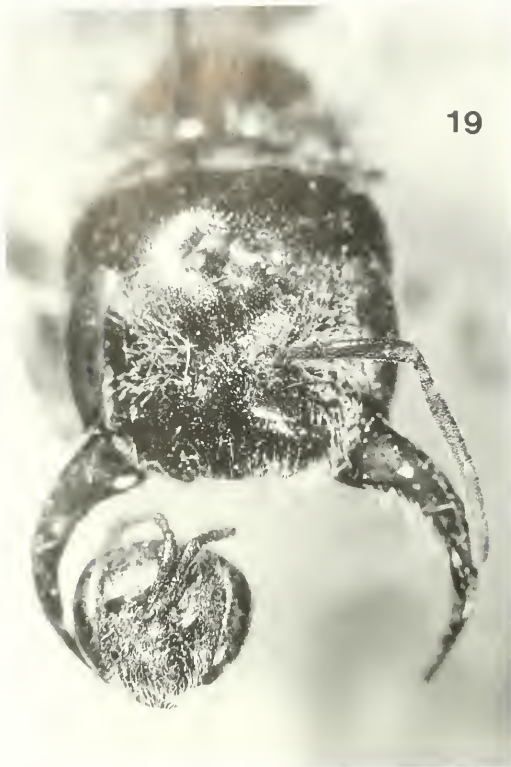
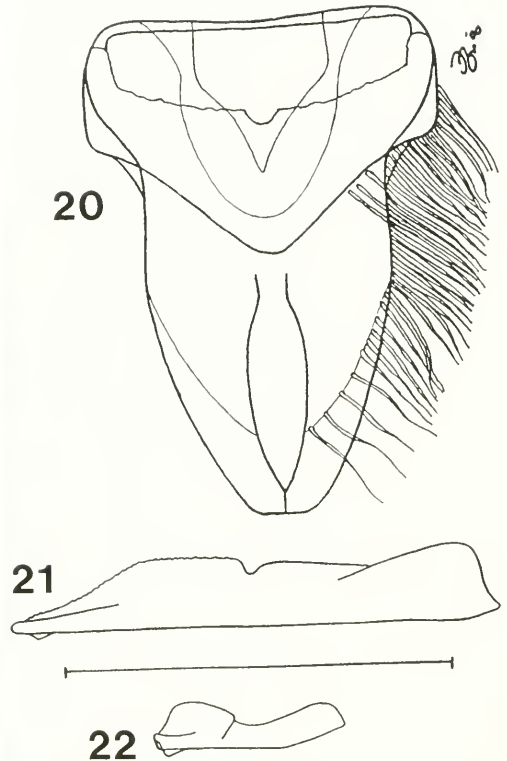

Fig. 19. *Halictus lanai*, macrocephalic female head (center) with worker (lower left) to show size difference between castes.

bronze-green reflections anteriorly on scutum and medially and along lateral margins of scutellum; remainder of mesosoma greenish-blue metallic except legs light amber-brown. Metasomal terga light brown on T1-3, T4 and T5 almost black, with weak metallic green reflections throughout, though somewhat more strongly in more posterior segments. Entire head and dorsal surface of mesosoma very shiny, completely lacking in background microsculpture. **Pubescence:** Off-white except for short appressed pubescence on metasomal terga 3 to 5 and all pilosity on the legs which are golden; mostly 1 od in length and sparse, particularly on dorsum of mesosoma. **Structure:** *Head* (Fig. 19): Massive, considerably wider than thorax, ratio of head width to intertegular distance 1.6:1; shape quadrate, slightly



Figs. 20-22. *Halictus lanai* labra. 20-21. Queen. 20, Dorsal view. 21, Lateral view. 22, Worker, lateral view. Scale bar = 1 mm.

wider than long. Labrum (Figs. 20, 21) with basal box only 1.5 times as wide as long, parallel sided, apical margin medially produced to give a pronounced V shape but with apex somewhat rounded; glandular area very weakly produced, U shaped, pores sparse; *distal process elongate, almost 1.5 times as long as basal width, laterally weakly convex, apex broadly rounded; marginal setae becoming widely separated in apical half where they arise from the dorsal surface of the labrum rather than the lateral margins;* median keel bisinuate, apical half with dorsal margin transversely concave, apical margin of keel concave; ventral surface of labrum completely flat. Mandibles enormous, reaching inner ventral margin of contralateral compound eye, narrowed and slightly outwardly curved beyond subapical tooth. Clypeus wide and short, length to width 1:4; very weakly convex,

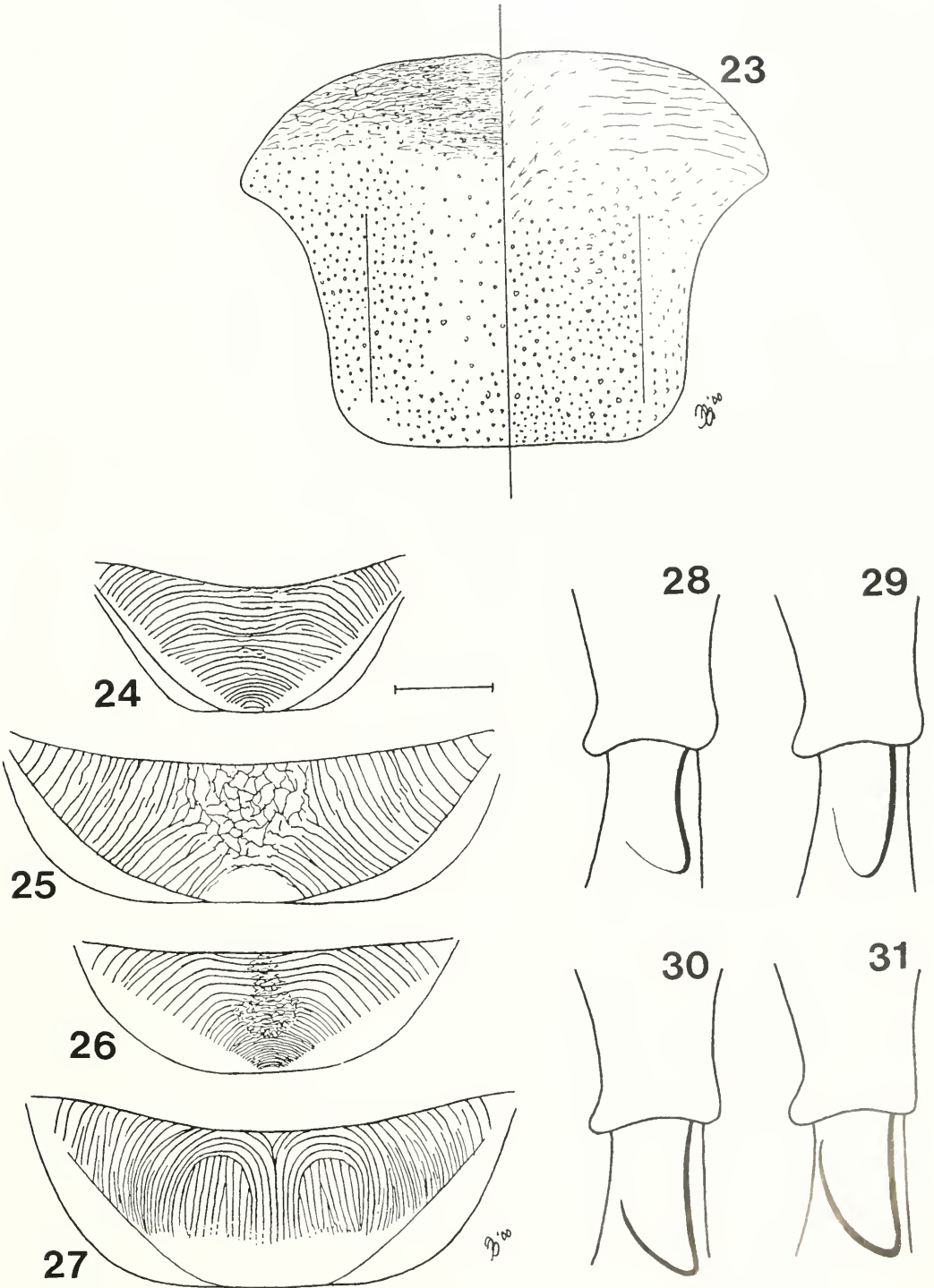

Figs. 23–31. *Halictus lanai* and *H. hesperus*. 23, Worker scutum showing punctation of *H. lanai* (left side) and *H. hesperus* (right side). 24–25. *H. hesperus*, propodea. 24, Worker, 25, queen. 26–27. *H. lanai*, propodea. 26, Worker, 27, queen. Scale bar = 0.3 mm. 28–29. *H. lanai*, basitibial plate. 28, Worker, 29, queen. 30–31. *H. hesperus*, basitibial plate. 30, Worker, 31, queen. Basitibial plates not to scale.

with blunt median tubercle, slightly depressed lateral to the tubercle, lateral clypeal teeth very short and obtuse; dorsal margin for the outermost quarter on each side completely straight and slightly oriented anteriorly, epistomal angle obtuse; punctures large and shallow with  $i = d$ . Supraclypeal area triangular, apical width twice its length, very weakly convex; sparsely punctured  $i = 2d$ . Compound eyes convergent above, UOD: LID 7:8; unusually small in comparison to remainder of head, length only 0.6 that of head. Frontal carina very short, extending from level with ventral margin of antennal socket to just above them. Punctures small and moderately dense, most dense ( $i \geq d$ ) around ocelli, becoming larger and sparser both anteriorly and posteriorly, particularly sparse on vertex ( $i = 3d$ ). Vertex swollen, such that head slightly wider at some distance behind compound eyes than across them; very long such that distance between lateral ocellus and posterior margin of vertex = 6od (Fig. 19); OOD 4od, IOD 2.5od; ocelli situated in shallow depressions. Gena postero-ventrally greatly elongate, almost twice as long as greatest width of compound eye, giving head a triangular appearance in lateral view. Hypostoma broad and flat, without teeth or other protuberances; hypostomal carina strong, particularly posteriorly. Mesosoma: Pronotum with lateral angles quadrate, strongly produced beyond scutum both anteriorly and dorsally, carinate anteriorly, carina continuous with strong pronotal lateral ridge; no carina on dorsal ridge; lateral surface with strong dorso-ventral striae. Scutum wider than long, ratio 6:5; median furrow deep such that anterior margin of scutum is biconvex, extending half length of scutum; parapsidal lines distinct, extending from near posterior margin to anterior  $\frac{2}{3}$ ths of scutum; punctures shallow, small, and sparse,  $i = 1.5d$ , except near antero-lateral corners where  $i = d$ . Scutellum 2.5 times as wide as long,  $\frac{2}{3}$ ths as long as scutum, very flat; punctures as on scutum but

denser around margins. Metanotum half as long as scutellum, uniformly, densely, and minutely punctured. Mesepisternum dorsoventrally striate on lateral and anterior surfaces, striae continuing transversely on ventral surface, posterior margin lacking striae, with a few weak punctures, this non-striate region is longer ventrally. Metepisternum dorsoventrally striate as in mesepisternum. Propodeum with dorsal surface two-thirds as long as scutellum, with approximately 40 fine, longitudinal striae which are strongly curved to give an almost fingerprint-like pattern (Fig. 27); striae do not reach apical margin of dorsal surface medially, space between striae and apical margin completely devoid of sculpture and very shiny; lateral surface microreticulate with sparse, minute punctures. Wings: veins amber except for costa, which is darker brown, membrane hyaline. Legs: Basitibial plate of hind leg with anterior margin only well defined at the apex, posterior margin well defined, apex pointed (Fig. 29); hind tibial spur with four teeth, the first twice as long as broad, the second as long as broad, the third and fourth successively shorter. Metasoma: Anterior of T1 microreticulate with small, weak, widely spaced punctures ( $i > 3d$ ); disk with very small, dense punctures,  $i = d$ ; apical impressed region weakly differentiated from remainder of tergum, 2od in length, similarly punctured as on disk; punctures on remaining gastral terga minute and somewhat sparser than on T1; apical impressed areas poorly differentiated; apical hair bands extremely weak, not extending ventrally.

*Worker.*—**Size:** Body length 5.8–6.5mm, head width 1.6–1.8mm, wing length 4.5–5mm. **Coloration:** Metallic green throughout except for apical  $\frac{1}{3}$  of clypeus dark brown; mandible amber with red-brown apical  $\frac{1}{3}$  and dark brown basal spot; antennae pale brown; femur and posterior surface of fore and sometimes mid-tibia brown, remainder of tibiae and tarsi amber; mesosomal venter brown, apical im-

pressions of terga translucent. **Pubescence:** Hairs white, slightly off-white on pleura and abdomen; mostly 1od long. **Structure:** *Head:* Slightly wider than long, rounded. Labrum (Fig. 22) with basal box twice as wide as long, anterior margin convex; glandular area strongly produced, medially divided almost completely by non-glandular depression to give it a bi-convex shape in apical view; distal process longer than basal width, laterally gently bisinuate, convex apically; with approximately 27 lateral setae; apical keel projecting for  $\frac{1}{5}$  its length beyond apex of distal process, flat ventrally, convex dorsally, subtruncate apically; narrowed to sharp dorsal margin. Mandible extending only slightly beyond opposing clypeal tooth; with blunt subapical tooth. Clypeus length to width 1:2.5; evenly and quite strongly convex; punctures weak, highly variable in size, anteriorly open and uneven in density with  $i = d$  apically and basally,  $i = 2-3d$  on disk. Supraclypeal area with anterior margin only slightly convex, almost straight; punctures as on clypeus but more clearly bimodal in size, with larger ones more numerous. Frontal suture extending from below antennal sockets to half the distance to median ocellus. Inner eye margins subparallel UID  $\approx$  LID. Frons with punctures larger, shallower, partly effaced and sparse ( $i = 1.5d$ ) lower on face to smaller, deeper, entire, and denser ( $i = d$ ) below ocelli. Vertex with IOD = 2od, OOD = 2od and distance from lateral ocelli to posterior margin of vertex 2od; punctures becoming increasingly sparse, small and effaced posteriorly. Gena with greatest width barely any greater than that of compound eye (1.1:1); without processes or angulation; punctures weak and effaced. Hypostoma flat without processes. *Mesosoma:* Pronotal lateral angle obtuse, lateral ridge weak, no stronger than the few, more posterior dorso-ventral carinae. Scutum slightly wider than long (1.1:1); straight between pronotal angles; slightly overhanging pronotum

medially; punctures small, shallow, slightly effaced transversely and sparse ( $i = 1.5-4d$ ), somewhat more dense and even laterad of parapsidal lines (Fig. 23). Medial suture extending half length of scutum, deeply impressed anteriorly; parapsidal lines extending from posterior  $\frac{1}{4}$  of scutum to anterior  $\frac{1}{3}$ ; ending in small pits both anteriorly and posteriorly. Scutellum medially unimpressed; punctures as on scutellum, but more uneven in size and density. Metanotum half length of scutellum; impressed medially; punctures effaced, surface shiny. Propodeum with dorsal surface intermediate in length between scutellum and metanotum; with striae transverse medially on basal half, arcuate, open posteriorly on posterior half, transverse laterally; in its entirety area appears like a broad fingerprint (Fig. 24); lateral surface with weak, effaced punctures in minute dorso-ventral roughening. Mesepimeron with weak, effaced punctures, background weakly dorso-ventrally microstriate; hypoepimeral area with weak, broad striae directed antero-dorsal to postero-ventrally. Metepisternum with coarse antero-dorsal-postero-ventrally directed weak, irregular striae. *Wings:* Veins pale straw in colour, membrane hyaline. *Legs:* *Basitibial plate of hind leg with anterior margin weakly defined at apex only, posterior margin well defined and sinuate* (Fig. 28). Inner hind tibial spur with 3 broadly rounded teeth, first much larger than others. *Metasoma:* T1 longer than broad (1.2:1); apical impressed area much wider medially (3od) than laterally (1od); background sculpture transversely microreticulate with small, weak punctures ( $i \leq 1.5d$ ) in anterior half, punctures becoming stronger and background sculpture weaker in apical half; apical impression minutely and sparsely punctured. T2 with punctures slightly larger and deeper than T1, without microsculpture. T3 with punctures more effaced, even more so on T4 and T5. Apical impressed areas on T2-5 2od in length.

*Male*.—**Size**: Total body length 7mm, maximal head width 1.5mm, forewing length 4.7mm. **Coloration**: Head metallic bluish green with slight bronze reflection medially, except clypeus which is brown with bluish green reflection basally, paling to yellowish amber non-metallic on apical  $\frac{1}{3}$ . Scape and pedicel brown, flagellum pale brown dorsally, dark amber ventrally, first annulus amber throughout. Pronotum and mesosomal venter brown with metallic bluish green reflection; mesosomal pleura and terga metallic green; propodeum metallic bluish green. Legs amber with fore and hind coxae pale brown. Metasomal terga metallic golden green, more weakly so on apically impressed areas. Sterna dark testaceous. **Pubescence**: White to cream coloured, mostly long (1.5–2o.d.) on face, gena, hypostoma, scutum, scutellum, metanotum, and mesosomal pleura. Shorter (1 o.d.) on vertex, even shorter ( $\frac{3}{4}$  o.d.) on anterior interocular area, intermixed with long, fine, and golden hairs on metasomal terga, and creamy white with pronounced branching on posterior propodeum, and laterally and anteriorly on metasoma. Very short ( $\frac{1}{2}$  o.d.), broadly plumose, and appressed on supraclypeal area, clypeus, dorsal surface of collar and of posterior lobe of pronotum, lateral and posterior margins of scutum, metanotal anterior margin, and on apical impressed areas of metasomal terga in worn or incomplete bands. **Structure**: *Head*: as wide as long, but appearing longer owing to narrowing at level of clypeus. Labrum not visible in undissected specimen. Malar area short, approx. 0.5 o.d. Clypeal width subequal to length; apical  $\frac{2}{3}$  projecting below lower tangent of eye margins; punctures large, shallow, and dense ( $d > i$ ), apically effaced. Supraclypeal area with smaller punctures apically and much smaller between toruli,  $d > i$ . Intraocular punctures small, and longitudinally effaced between torulus and compound eye; small, deep, distinct, and crowded ( $d > 2i$ ) on frons; slightly larger on vertex, effaced

and more widely spaced posteriorly on vertex. Gena and vertex unmodified. Antenna reaching posterior margin of scutellum; scape 3 times as long as apical width; pedicel shorter than wide; A1 shorter than wide, all remaining flagellar annuli twice as long as wide. *Mesosoma*: Pronotum with lateral ridge weakly angulate; pronotal angle wide but distinct; collar chagrined. Scutum length  $\frac{3}{4}$  width; slightly produced anteriorly between pronotal lateral angles, otherwise flat anterior margin; not overhanging pronotum; median furrow distinct, extending half length of scutum; parapsidal lines weak, extending to anterior  $\frac{1}{3}$ ; punctures moderate in size and deep,  $d \geq i$ , weaker and slightly effaced anteriorly, slightly sparser ( $d = i$ ) posteriorly. Scutellum slightly less than half as long as scutum; punctures small anteriorly,  $d = 2i$ ; becoming denser, larger, and irregular posteriorly, where  $d \approx i$ ; most dense on postero-lateral corners and posterior margin. Metanotum less than  $\frac{1}{2}$  length of scutellum; very narrow medial longitudinal area marked by very small contiguous and deep punctures; lateral to this punctures small,  $d = i$ ; extreme lateral margin with punctures larger and effaced into rugae. Mesepisternum rugose to weakly dorso-ventrally striate anteriorly; hypopimeron rugose. Metepisternum rugostriate in antero-posterior direction. Propodeum length subequal to scutellum; arcuate striate with arcs open posteriorly, striae confused medially, giving them impression of rugae; smooth at postero-lateral margins; laterally rugose; posterior face with small punctures  $d > i$ ; lateral carinae extending nearly half height. *Wings*: Veins, prestigma, and stigma pale honey coloured, costa brown, membrane hyaline. *Metasoma*: Terga with apical impressed areas up to 1o.d. long medially and 0.5 o.d. laterally, most distinctly marked on T1, and weaker and shorter on subsequent terga to imperceptible as an impression on T5; dorsal surface not sinuate in profile. T1 60% long as wide; lateral swellings dis-

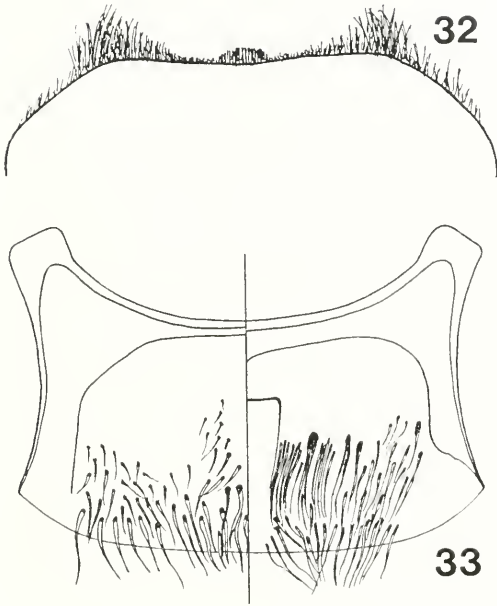

Figs. 32–33. *Halictus sterna*. 32, *H. lanei*, sternum 5, apical view. 33, Sternum 6, ventral, *H. hesperus* (right), *H. lanei* (left).

tinct; area anterior to brow transversely microrugulostriate, brow with shining background and small punctures ( $d < i$ ); punctures on disc dense,  $d > 2i$ , sparser across lateral swellings; punctures on impressed area smaller and very dense ( $d > i$ ). Punctures small,  $d = i$ , becoming increasingly more effaced on subsequent terga; apical impressed areas of subsequent terga with punctures as on discs, slightly smaller and sparser on T5 and T6. S4 weakly concave apically. S5 with a short medio-apical tuft of fine erect hair,  $\frac{3}{4}$  o.d. long and wide, hairs  $\frac{3}{8}$  o.d. long (Fig. 32). S6 with wide medial longitudinal impunctate, glabrous, depressed area bordered by long hairs (Fig. 33). *Terminalia*: S7 triangular with pointed apex. S8 with triangular medial projection on rounded stepped base (Fig. 34). Gonobase long, concave laterally; median suture distinct only basally; small medio-dorsal cleft in apical margin; anterior ventral margin obtusely angled (Fig. 35); ventro-lateral arms converging apically, though not touching. Gonocoxae with

latero-basal concavity; ventral bridge very deep, basal margin deeply and abruptly concave; lacking dorsal striations. Gonostylus with body approximately half length of gonocoxe; rectangular in lateral view with basal width slightly shorter than apical width and with dorsobasal margin produced; apical inner surface bearing numerous hairs; inner margin bearing 6 thick and apically swollen hairs directed mesad; anteriorly directed portion of recurved apical projection narrowed to a blunt point; apical stylus long,  $\frac{3}{4}$  length of gonostylus body, narrow, recurved dorsally, and bearing long branched hairs. Second gonostylus absent. Penis valve with tips dorsoventrally flattened, bluntly pointed, and apically slightly recurved dorsad; penis valve ventro-basal projection long and narrow.

*Specimens examined*.—We have observed workers from Conceicao do Araguaia, Para, Brazil, collected in July, and from Lara, Venezuela, collected in June, and from Merida, Venezuela, no date from the Cornell University collection. The single male was found in a collection at the Carnegie Museum of Natural History, bearing the label: Boqueirao, Rio Grande, Brazil, collected on January 8, 1908, also labeled Carn. Mus. Acc. 3533 along with a series of 9 females labeled Barra Bahia, Brazil, Dec. 6 1907, Carn. Mus. Acc. 3533.

The large female specimen described here has been identified by Padre Moure as belonging to *Pachycephala lanei*, the name by which this species was known prior to its recognition as a member of the genus *Halictus* by Michener (1954). It bears no locality label and is in the Cornell University collection. Our specimen is larger and hence somewhat more macrocephalic than the type, photographs of which were kindly sent to us by Dr. Danuncia Urban of Curitiba. More interestingly, our specimen has the striations of the propodeal enclosure partly longitudinal, much more so than the type specimen or the workers, in which they are primarily transverse. While it is not impossible that this single

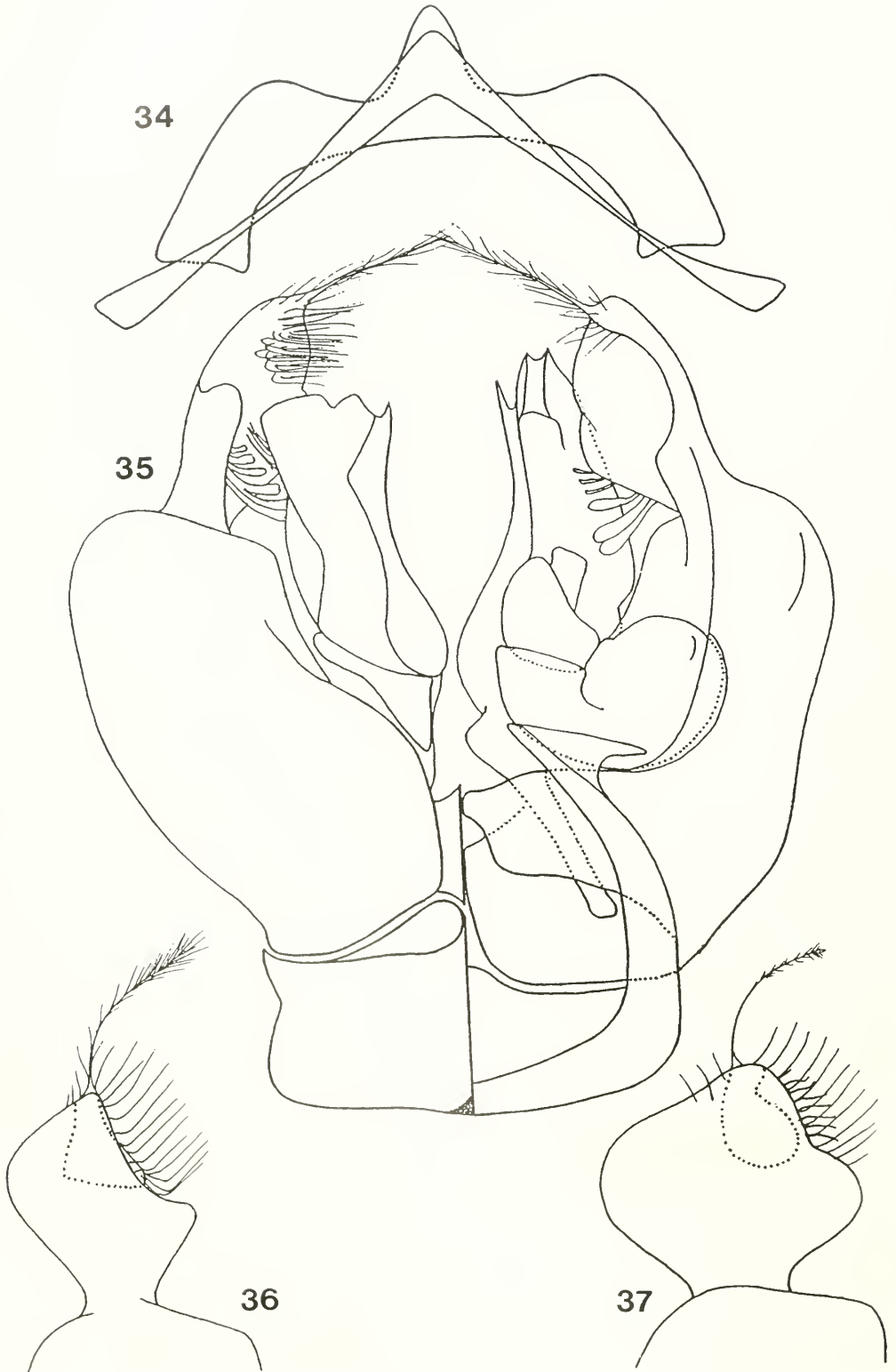

specimen represents a species distinct from *H. lanei* we take the more conservative position and ascribe the variation in propodeal sculpture to allometric variation. In support of this conclusion is the observation that queens of the closely related *H. hesperus* also have most of their propodeal striae longitudinal whereas those of the workers are transverse (compare Figs. 24 and 25 for worker and queen, respectively).

*Discussion.*—Only two other *Seladonia* species come close to the geographic range of *H. lanei*: *H. hesperus*, and *H. lutescens*. Females of the latter are readily separable from those of the other two species because of their largely orange metasoma, dense punctation on the scutum with  $i < d$  and their entirely rugulose dorsal propodeal surface. Both queens and workers of *H. lanei* are distinguishable from those of *H. hesperus* by the incomplete basitibial plate of the hind leg (Figs. 28–31). In *H. hesperus* the basitibial plate is entire whereas in *H. lanei* it is absent anteriorly except at the extreme apex. This reduced anterior margin of the plate is also shared by both large and small females of *H. lutescens*. Furthermore, queens of *H. hesperus* have an angle on the hypostomal carina rather than on the gena (Brooks and Roubik, 1983), the latter being evenly convex in both *H. hesperus* and *H. lutescens*, but markedly produced in large specimens of *H. lanei* as noted above.

Differentiating between the workers of *H. hesperus* and *H. lanei* is more problematic. Other than the basitibial plate character mentioned above, the most readily detectable difference appears to be in the nature of the scutal punctation (Fig. 22). In *H. hesperus* the punctures are shallow

and largely effaced in an approximately triangular area between the central point of the scutum and its antero-lateral corners. Elsewhere they are better defined, separated by interspaces that approximate their own diameters and quite variable in size with some comparatively large and shallow punctures among the rest. In contrast, the scutal punctures of *H. lanei* are partly effaced throughout the scutum, nowhere are they as strongly effaced as in the anterior region of the scutum of *H. hesperus* but they are more uniformly so. The punctures of *H. lanei* workers are also more widely spaced, with  $i \geq 1.5od$ .

Most of the interesting aspects of the morphology of the large specimen—the labrum (Figs. 20, 21), the extreme length of the mandibles (Fig. 19), enormous swollen head, very long gena, and the enlarged pronotal angles—are attributable to extreme caste dimorphism. Indeed, with a head width of 3.1mm, this queen-like individual is twice as large as the smallest worker we have available for study (Fig. 19). Translating these linear measurements into mass, it is possible that this queen weighs 8 times as much as the smaller workers. Halictines take approximately 8 foraging trips to produce a pollen ball that yields an individual of the same size as the forager. It is known for *H. hesperus* that the workers produced by the queens are smaller than the later emerging workers (Packer, 1985). This leads to the intriguing possibility that queens of this species can produce a worker from a single foraging trip.

The male *H. lanei* is easily distinguished from *H. lutescens* and *H. hesperus*, and in fact all other *Seladonia*, by the unique genitalic and sternal characters, though again,

←

Figs. 34–37. *Halictus* terminalia. 34–36. *H. lanei*. 34, Sterna 7 and 8. 35, Genital capsule, dorsal view (left), ventral (right). Dorsal and ventral views shown at angles optimizing view of relevant structures, not symmetrical. 36, Gonostylus, lateral view. 37. *H. (S.) hesperus*, gonostylus, lateral view. Hairs and portions of hairs behind other structures not drawn.

only *H. hesperus* has a geographic range approaching that of *H. lanei*. In addition to the unique features of *H. lanei*, males of the two species can be distinguished by the following characters: *H. hesperus* has the anterior punctures on the scutum stronger and more effaced than *H. lanei*, with the scutum also more swollen anteriorly on either side of the median suture such that it appears biconvex and the punctures of the scutum and scutellum are more dense in *H. hesperus* than *H. lanei*. *Halictus hesperus* has darker legs, especially the coxae and trochanters, which are all brown in this species. S6 of *H. hesperus* has a shallow, ill-defined, impressed, glabrous area which does not reach the apex of the sternum and is separated from the apex by a region which is hirsute like the lateral areas. Conversely, in *H. lanei* the impression on S6 is deep, with a well defined, transverse anterior margin, and it reaches the apex of the sternum (Fig. 33). The genitalia also differ between the two species. In dorsal view, the gonobase of *H. lanei* is  $\frac{3}{4}$  as long as it is wide, whereas in *hesperus*, it is less than  $\frac{2}{5}$  as long as wide, and is much more rounded; the gonostylus of *H. hesperus* is more quadrate, with a less pronounced dorso-basal projection and has a stronger swelling ventrally; this species also has denser hair on the dorsally recurved part of the gonostylus (compare Figs. 36 and 37); and the medially directed apico-dorsal projection of the penis valve is more pronounced in *H. hesperus* than in *H. lanei*.

The hair patch on the fifth sternum of the male is reminiscent of a similar feature in many species of the subgenus *Vestitohalictus*. However, in *Vestitohalictus* the hair tuft is most commonly found on the fourth sternum (Michener, 1978), although in some species, such as *H. (V.) concinnus* it is repeated on the fifth sternum (Packer, unpublished data). Owing to the presumed phylogenetic position of these subgenera and species, it is unlikely that this

hair tuft is homologous between the two subgenera.

## ACKNOWLEDGMENTS

We would like to thank the following for helping us obtain specimens required for this study or to obtain further information about the specimens: the late Professor George Eickwort of Cornell University; Dr. Terry Griswold of the USDA bee lab, Logan, Utah; David Hawks and Dr. Douglas Yanega of the University of California, Riverside; Dr. Albert Finnamore of the Provincial Museum of Alberta; Dr. Jon Gelhaus of the Philadelphia Academy of Sciences; Dr. John Rawlins of the Carnegie Museum and Dr. Danuncia Urban of Curitiba. Dr. Bryan Danforth kindly supplied drawings of S7 and S8 of a male of *H. harmonius* before we found additional specimens in the collection at Riverside. We thank Drs. Mike Engel and Eric Grissell for helpful comments on the manuscript. Our research was funded by an NSERC graduate scholarship to the senior author and an NSERC research grant to the junior author.

## LITERATURE CITED

- Brooks, R. W. and D. W. Roubik. 1983. A halictine bee with distinct castes: *Halictus hesperus* (Hymenoptera: Halictidae) and its bionomics in central Panama. *Sociobiology* 7:263-282.
- Eickwort, G. C. 1969. A comparative morphological study and generic revision of the augochlorine bees (Hymenoptera: Halictidae). *University of Kansas Science Bulletin*. 48:325-524.
- Krombein, K. V., P. D. Hurd Jr., D. R. Smith, and B. D. Burks. 1979. *Catalog of the Hymenoptera of America North of Mexico, vol. 2, Apocrita*. Smithsonian Institution Press, Washington, xvi + pp. 1199-2209.
- McGinley, R. J. 1986. Studies of Halictinae (Apoidea: Halictidae). I. Revision of New World *Lasioglossum* Curtis. *Smithsonian Contributions to Zoology*, No. 429. 294pp.
- Michener, C. D. 1954. Bees of Panama. *Bulletin of the American Museum of Natural History*. 104:1-175.
- Michener, C. D. 1978. The classification of halictine bees: tribes and Old World non-parasitic genera with strong venation. *University of Kansas Science Bulletin* 51:501-538.
- Michener, C. D., R. J. McGinley, and B. N. Danforth. 1997. *The bee genera of North and Central America*. Smithsonian Institution Press, Washington, viii+209pp.
- Moure, J. S. 1940. Apoidea neotropica. *Arquivos do Zoologia Sao Paulo*. 2:36-64.
- Packer, L. 1985. The social organisation of two halictine bees from southern Mexico with notes on two bee-hunting philanthine wasps. *Pan-Pacific Entomologist* 51:291-298.

- Packer, L., and J. S. Taylor. 1997. How many cryptic species are there? An application of the phylogenetic species concept to genetic data for some comparatively well known bee species. *Canadian Entomologist* 129:587–594.
- Rosenmeier, L., and L. Packer. 1993. A comparison of genetic variation in two sibling species pairs of haplodiploid insects. *Biochemical Genetics* 31:185–200.
- Sandhouse, G. A. 1941. The American species of the subgenus *Halictus*. *Entomologica Americana, New Series* 21:23–38.
- Walker, K. 1995. Revision of the Australian native bee subgenus *Lasioglossum* (*Chilalictus*) (Hymenoptera: Halictidae). *Memoirs of the Museum of Victoria* 55:1–423.
- Wille, A., and C. D. Michener. 1971. Observations on the nests of Costa Rican *Halictus* with taxonomic notes on Neotropical species (Hymenoptera: Halictidae). *Revista de Biología Tropical* 18:17–31.

## The New Western Australian Tiphid Genus *Dythynnus* Kimsey (Hymenoptera: Tiphidae: Thynninae)

LYNN S. KIMSEY

Bohart Museum of Entomology, Department of Entomology, University of California,  
Davis, CA 95616

---

*Abstract.*—The new genus *Dythynnus* Kimsey is described from Western Australia based on the new species *solaris* Kimsey and *thermophilus* Kimsey (type of genus).

---

Northern and central Western Australia are among the most poorly collected regions in Australia. A large number of thynnine species from this area fail to fit into established genera. Although the precise relationships between *Dythynnus* Kimsey and other Australian thynnine genera remain unresolved, preliminary phylogenetic analyses of these genera suggest that *Dythynnus* is at least a basal lineage of a clade containing genera related to *Iswaroides* Ashmead, as discussed by Kimsey (1999). This is based upon a number of male characteristics including the laterally notched transverse pronotal carina (welt), the epipygium subapically with a partial transverse carina, volsella U-shaped in cross-section, gonobase narrowly attached to gonocoxa, and slender penis valves. This genus also has the palpal brush seen in *Chilothyunnus* Brown.

Specimens were obtained through extensive collecting in Western Australia. Both holotypes will be placed in the Western Australian Museum, Perth. Paratypes will be dispersed between the Australian National Insect Collection, CSIRO, Canberra, ACT, the Bohart Museum of Entomology, University of California, Davis, USA, and the Western Australian Museum. The terms hypostomal plate and hypostomal carina are used in the sense of Bohart and Menke (1976).

### *Dythynnus* Kimsey, new genus

*Male.*—Body length 6–9 mm. *Head:* clypeus narrowly truncate apically, truncation round cornered and 1–2 midocellus diameters across; antennal lobes small, closely aligned and rounded, without ridge or carina, strongly elevated above subantennal sclerite; frons with frontal line extending nearly to midocellus; labrum small and apically bilobate; vertex without red spot behind hindocellus; basal maxillary palpal segment with long, erect setae; hypostomal plate extending to outer mandibular socket; occipital and hypostomal carinae narrowly to broadly separated ventromedially; prementum asetose, longitudinally grooved laterally; stipes with sparse marginal fringe, traversing stipes at midpoint; flagellomere I 1.5–2× as long as broad; flagellomere II 2.5–3× as long as broad; flagellomeres without tyloids or with single, often indistinct, subapical one. *Mesosoma:* pronotal disk anterior margin marked by transverse swelling or broad ridge, without medial or sublateral indentations or notches; scrobal sulcus shallow, extending less than half way across mesopleuron; propodeum sloping obliquely from metanotum to petiolar socket; forecoxa globular to flat, medially setose to asetose; legs unmodified except hindtrochanter produced posteriorly into sharp apical angle or tooth. *Metasoma:* tergum I about as broad as long,

gently convex subapically, sternum I medially convex; terga I–VI and sterna II–V each with subapical transverse sulcus; terga I–V each with subspiracular sulcus; epipygium with thin subapical transverse carina or none, with thin to broad apical transparent rim; hypopygium narrowly triangular with transparent lateral edge. *Genital capsule* (as in Figs. 3–5, 8–10): gonocoxa dorsoapically lobate; gonobase narrowly attached to gonocoxa in lateral view; paramere apically bilobate or truncate; aedeagus with long apical loop; volsella large, U-shaped in cross section, with slender inner and outer lobes (as in Figs. 6, 11); penis valves slender apically. *Color*: black, strongly marked with yellow, orange and red.

*Female*.—Unknown.

*Type species*.—*Dythyinnus thermophilus* Kimsey, new species.

*Etymology*.—The generic name is a nonsense combination of letters added to the commonly used suffix in this tribe—"thyinnus". The name is assumed to be masculine.

*Included species*.—*Dythyinnus solaris* Kimsey, new species and *Dythyinnus thermophilus* Kimsey, new species.

*Distribution*.—This genus is known from two regions in Western Australia, the Stirling Range (*solaris*) and 100+ km north of Northampton (*thermophilus*), in the summer months of December and January.

*Discussion*.—*Dythyinnus* species can be immediately separated from other Australian genera by the sparse, arcuate stipal fringe, occipital and hypostomal carinae broadly separated, flagellomeres without or with only a single tyloid, laterally notched pronotal welt, epipygium with broad, polished and impunctate apicomedial area, and basal maxillary palpal segments with erect brush-like setae. The brushy palpal segments are similar to those seen in *Chilothynnus* Brown. However, the closely aligned antennal sockets (about 1 midocellus diameter apart), elongate and narrowly triangular hypopy-

gium, and arcuate stipal fringe will immediately separate *Dythyinnus* from *Chilothynnus*.

*Dythyinnus solaris* Kimsey, new species  
(Figs. 1, 3–7, 12)

*Male*.—Body length 6–7 mm. *Head* (Fig. 1): facial punctation contiguous to 1 puncture diameter apart, punctures becoming larger on frons; vertex with punctures behind ocelli 1–2 puncture diameters apart; clypeal apex  $0.2 \times$  greatest width of clypeus; clypeus greatest width  $2.6 \times$  length; face  $1.2 \times$  as long as greatest width above antennal sockets; midocellus  $4.2$  midocellus diameters from nearest eye margin; flagellomere I  $1.7 \times$  as long as broad; flagellomere II twice as long as broad; flagellomere III  $2.5 \times$  as long as broad. *Mesosoma*: pronotal and scutal punctures 1–2 puncture diameters apart; scutellar punctures 2–4 puncture diameters apart; metanotum nearly impunctate; propodeal punctures nearly obscured by dense, fine, transverse ridges, smooth and impunctate anteriorly; mesopleural punctures  $0.5$ – $1$  puncture diameter apart; propleuron convex and setose; forecoxa convex, covered with long setae, setae becoming densest in medial patch; *Metasoma*: terga and sterna highly polished, punctures small and shallow, 2–4 puncture diameters apart; epipygium subapically narrowed with broad transparent rim; hypopygium (Fig. 12). *Genital capsule* (Figs. 3–5): paramere broad and apically truncate in lateral view, apex bending toward midline, dorsally densely setose; gonocoxa dorsally broadly bilobate, dorsal surface depressed sublaterally; volsella with slender digitate inner lobe and broader, acute outer lobe (Fig. 6). *Color*: head black, with whitish band along eye margin and becoming reddish behind vertex; clypeus and mandible whitish; frons with short whitish band above each antennal socket; occiput and hypostoma black; pronotum black, with transverse anterior and posterior whitish bands; scutum and scutellum black, with whitish

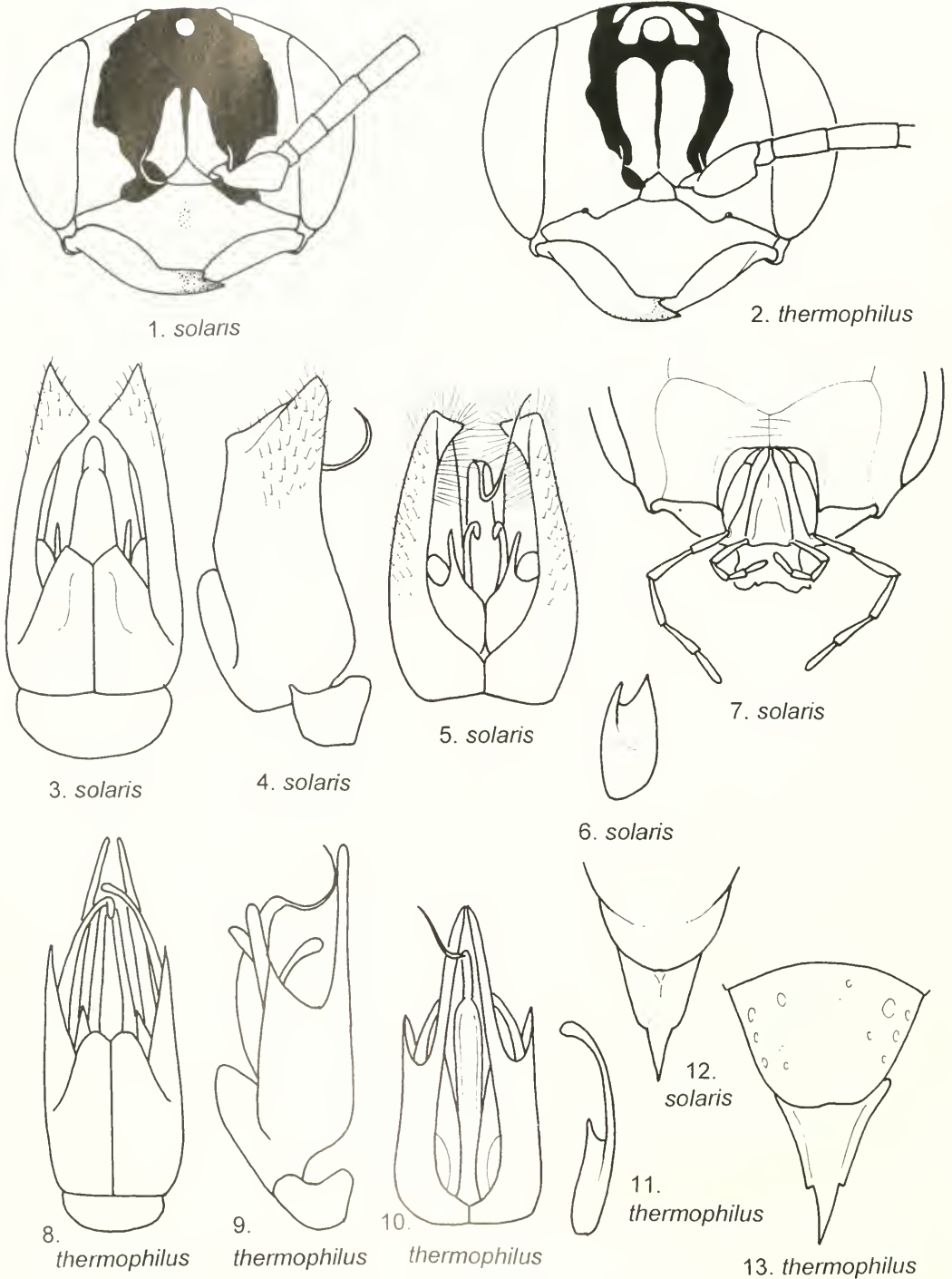

Figs. 1-13. *Dythymus* species. 1, 2, Front view of male face, left antenna not shown. 3, 8, Dorsal view of genital capsule. 4, 9, Lateral view of genital capsule. 5, 10, Ventral view of genital capsule, with gonobase removed. 6, 11, Ventral view of volsella. 7, Ventral view of male head, with occipital region not shown. 12, 13, Dorsal view of metasomal segment VII, tergum and sternum.

medial and lateral spots; metanotum black, with whitish medial spot; propodeum black; mesopleuron black, with whitish comma-shaped anterior and rounded posterior spots; propleuron black; forecoxa black, with large medial whitish spot and interior black spot (corresponding with tuft of long setae); forelegs red; mid and hindlegs, coxae black becoming whitish dorsally, trochanters brown, femora red, tibiae red ventrally, brown dorsally, tarsi brown; metasomal tergum II black, with pale lateral spot; terga III–VI reddish brown, becoming darker posteriorly, with pale whitish lateral spot; terga VII–VIII dark brown to black; sternum II black; sterna III–VII red; sternum VIII dark brown; wing veins brown, becoming pale basally; wing membrane untinted.

*Type material*.—Holotype ♂: 7 km n Stirling Range, 34°19'S 118°11'E, 23–25 Dec. 1994, L. S. & R. B. Kimsey, ex *Eucalyptus* flowers, field No. WA122401 (PERTH). Paratypes: 1 ♂ : same data as holotype; 1 ♂ : 24 Dec. 1994; 1 ♂ : 23–26 Dec. 1994; 3 ♂ : 24–26 Dec. 1994, field No. WA122305 (CANBERRA, DAVIS, PERTH).

*Etymology*.—The species name means “of the sun”, Latin, masculine; it refers to the intense summer conditions when the males fly.

*Discussion*.—*Dythyinnus solaris* can be distinguished from *thermophilus* by the apically truncate parameres, flagellomere I less than twice as long as broad, pale, whitish markings, and entirely black propodeum.

***Dythyinnus thermophilus* Kimsey, new species**  
(Figs. 2, 8–11, 13)

*Male*.—Body length 6–9 mm. *Head* (Fig. 2): face highly polished; subantennal sclerite impunctate; clypeal punctures 3–5 puncture diameters apart; area between antennal socket and eye nearly impunctate; frons and vertex highly polished, punctures 2–8 puncture diameters apart;

clypeal apex 0.2× greatest width of clypeus; clypeus greatest width 2.6× length; face 1.3–1.4× as long as greatest width above antennal sockets; midocellus 2.8 midocellus diameters from nearest eye margin; flagellomere I 2.2× as long as broad; flagellomere II 3× as long as broad; flagellomere III 3.2–3.5× as long as broad. *Mesosoma*: pronotum, scutum and scutellum highly polished, punctures 4–8 puncture diameters apart, becoming denser laterally; metanotum nearly impunctate; propodeum impunctate medially, punctures 1–2 puncture diameters apart laterally; mesopleuron highly polished, punctures 2–4 puncture diameters apart; propleuron convex and evenly setose; forecoxa slightly flattened and nearly asetose in most specimens. *Metasoma*: tergal punctures tiny and obscure, 1–4 puncture diameters apart anteriorly, markedly larger and denser on tergum VII; sternal punctures 1–4 puncture diameters apart; epipygium with thin, transverse, subapical carina, and narrow, transparent apical rim; hypopygium (Fig. 13). *Genital capsule* (Figs. 8–10): paramere strongly bilobate, with acute dorsal lobe and elongate digitate ventral one, nearly asetose; gonocoxal dorsal lobes broadly rounded, overall appearing shallowly bilobate dorsomedially; volsella with long digitate outer lobe and much shorter, acute inner lobe (Fig. 11). *Color*: Head yellow, except frons midline brown to black in some specimens, and black line extending dorsally above antennal sockets connecting with line forming box around ocelli; some specimens with brown line extending from posterior eye margin and across vertex behind ocelli; occiput black; pronotum yellow except transverse medial stripe and anterior face; scutum black, with large tridentate medial spot and yellow laterally; scutellum yellow, with black anterior margin connected to sublateral black band; metanotum yellow medially and anteriorly, black laterally; propodeum black, with broadly triangular yellow medial spot and large

comma-shaped lateral yellow spot; propleuron black, with large yellow medial spot; coxae yellow, with black base; mid and forelegs yellow and red, with apical tarsomeres brown (tibiae and femora may be entirely yellow, and foretarsi yellow in some specimens); hindfemur red, yellow laterally, hindtibia red, hindtarsomeres brown; mesopleuron black, with most or all of lateral surface yellow, scrobal sulcus marked by black and brown in some specimens; metasomal tergum II black basally, yellow submedially and red posteriorly; terga III–VI each red becoming brown posteriorly, each with large yellow lateral spot or complete yellow band; metasomal sterna red, except sternum VIII dark red to black; wing veins pale brown, becoming paler basally; wing membrane untinted.

*Type material*.—Holotype ♂: 115 km n Northampton, 9 Jan. 1995, 27°27'S 114°41'E, R. B. & L. S. Kimsey, ex *Eucalyptus*

flowers, field No. WA010905 (PERTH). Paratypes: 19 ♂: same data as holotype; 9 ♂: 120 km n Northampton, 27°25'S 114°40'E, R. B. & L. S. Kimsey, ex *Eucalyptus* flowers, field No. WA010904 (CANNONBERRA, DAVIS, PERTH).

*Etymology*.—The name, “*therme*”, “*philus*”, means heat-loving, Greek, masculine; it refers to the hot summer conditions encountered when the specimens were collected.

*Discussion*.—This species can be readily distinguished from *solaris* by the strikingly bilobate parameres, much longer first flagellomere and bright yellow markings, particularly the yellow medial propodeal spot.

#### LITERATURE CITED

- Bohart, R. M. and A. S. Menke. 1976. *Sphexid wasps of the world*. University of California Press, Berkeley, ix + 695 pp.
- Kimsey, L. S. 1999. What is the real *Iswaroides*? *Proceedings of the Washington Entomological Society* 101:503–513.

**Effects of Parasitism by *Banchus flavescens*  
(Hymenoptera: Ichneumonidae) and *Microplitis mediator*  
(Hymenoptera: Braconidae) on the Bertha Armyworm, *Mamestra  
configurata* (Lepidoptera: Noctuidae)<sup>1</sup>**

P. G. MASON<sup>2</sup>, M. A. ERLANDSON, AND B. J. YOUNGS

Agriculture and Agri-Food Canada, Saskatoon Research Centre, 107 Science Place,  
Saskatoon, Saskatchewan S7N 0X2

---

*Abstract.*—The bertha armyworm, *Mamestra configurata* Walker (Lepidoptera: Noctuidae), is an important pest of canola (*Brassica napus* L. and *B. rapa* L.) and flax (*Linum usitatissimum* L.) in western Canada. It is the focus of research to develop a management program integrating microbial and insect parasitoid agents with cultural practices and judicious use of chemical insecticides. To develop IPM effectively it is essential to understand the impact of parasitism on feeding activity of the host. We studied the effect of parasitism by two solitary koinobiont larval endoparasitoids: *Banchus flavescens* Cresson (Ichneumonidae) is a native parasitoid of *M. configurata*; and the European *Microplitis mediator* (Haliday) (Braconidae) is a candidate for introduction to enhance the biological control effected by *B. flavescens*. Parasitism by *B. flavescens* resulted in significantly decreased food consumption and lower biomass production but did not reduce the time that the pest would occur in the crop. Host larvae parasitized by *M. mediator* showed a much greater reduction in food consumed, weight gained, frass produced and the host's feeding time compared to nonparasitized larvae or those parasitized by *B. flavescens*. Management strategies should consider options that would minimize impact on parasitized larvae and introduction of *M. mediator* could benefit integrated management programs for *M. configurata*.

---

The bertha armyworm, *Mamestra configurata* Walker, native to North America, has been the focus of studies to determine the role of natural control agents for this pest of canola (*Brassica napus* L. and *B. rapa* L.: Brassicaceae) and flax (*Linum usitatissimum* L.: Linaceae), the two most important oilseed crops grown in western Canada. Important natural control agents of larval stages of the bertha armyworm include viral and fungal diseases and parasitic wasps and flies (Wylie 1977, Wylie and Bucher 1977, Arthur and Mason 1985, Turnock 1988, Erlandson 1990). The solitary koinobiont ichneumonid *Banchus flavescens* Cresson is the single most

important larval parasitoid, occurring in more than 90% of bertha armyworm sampled in years when populations are declining (Turnock and Bilodeau 1984, Arthur and Mason 1985) yet *B. flavescens* is unable to prevent outbreaks from occurring (Mason *et al.* 1998).

Biologically based pest management strategies being developed for the bertha armyworm include microbial insecticides (nuclear polyhedrosis virus, MacoNPV (Erlandson 1990)) and introduction of exotic parasitoids to complement the mortality caused by native natural enemies. It is essential to understand the impact of parasitoids on the host's feeding activity so that management strategies can be developed to minimize the impact on parasitoids.

The solitary koinobiont braconid parasitoid *Microplitis mediator* (Haliday) has been

---

<sup>1</sup> Saskatoon Research Centre Contribution No. 1272.

<sup>2</sup> Present address, Agriculture and Agri-food Canada, Eastern Cereal and Oilseed Research Centre, Ottawa, Ontario, K1A 0C6 Canada.

studied as a candidate for introduction to enhance natural biological control of *M. configurata*. *M. mediator* attacks the cabbage moth, *Mamestra brassicae* (L.), in its native habitat in Europe (Slovak 1985a, 1985b, Johansen 1997). It is synchronized with its host in both uni- and bivoltine systems. Arthur and Mason (1986) demonstrated that *M. mediator* will attack and successfully parasitize 1<sup>st</sup> to 3<sup>rd</sup> instar bertha armyworm larvae, although 3<sup>rd</sup> instars frequently repel or injure female wasps attempting to oviposit. The fully developed parasitoid larva egresses from the host's 4<sup>th</sup> instar, regardless of the instar parasitized (Mason, unpublished) while non-parasitized larvae complete 6 instars and then pupate.

Evaluation of the impact of candidate biological control agents on the target ecosystem is a necessary component of biological control screening projects. An important part of this process is to determine the effect of the agent on the crop being protected. Although idiobiont parasitoids normally kill the host immediately (eliminating further plant feeding) koinobiont insect endoparasitoids generally do not kill immediately and permit feeding by the host for at least a short period of time after parasitization (Askew and Shaw 1986, Quicke 1997). Thus, determination of the effect of koinobiont parasitism on the host's feeding is an indirect means for determining the impact of parasitoids on the crop being protected. Depending on parasitoid biology, parasitism can reduce (Rahman 1970, Guillot and Vinson 1973, Brewer and King 1978, Sajap *et al.* 1978, Brewer and King 1980, Parkman and Shepard 1981, Shaw 1981, Powell 1989, Kumar and Ballal 1992, Ohnuma and Kainoh 1992, Khan 1994, Yang *et al.* 1994, Harvey 1996), increase (Rahman 1970, Hunter and Stoner 1975, Byers *et al.* 1993) or have no effect on (Brewer and King 1981) feeding by lepidopteran host species. Parasitoids that elicit decreased feeding by the host reduce potential damage to the crop in addition to removing the

host from the reproductive pool for subsequent generations.

The application of insecticides for control of bertha armyworm usually takes place during the pod development stage of canola, when the larvae are in the 5<sup>th</sup> and 6<sup>th</sup> instars. The decision to apply insecticides is based on evidence of real or potential (often visibility of larvae) crop damage. Because insecticides may have a negative impact on adult and larval parasitoids, understanding parasitoid biology is important to develop sound pest management strategies. Arthur and Mason (1985, 1986) showed that *B. flavescens* and *M. mediator* oviposit in 1<sup>st</sup> to 3<sup>rd</sup> instar bertha armyworm which are inconspicuous and feed on canola leaves before pods develop. Because no control measures are taken during these life stages of the pest, adult *B. flavescens* and *M. mediator* are not exposed to insecticides when they are searching in the foliage of the canola crop. Further, they are unlikely to be present when insecticides are applied during the 5<sup>th</sup> and 6<sup>th</sup> larval instars because the preferred instars for oviposition are not present. In contrast, parasitized host larvae may still be present when insecticides are applied. For example, parasitoid species that prolong development of the host by increasing or making no difference in the amount of food consumed by the pest are more likely to be indirectly exposed to and negatively impacted by control measures such as chemical insecticides that kill on contact and are usually used against mature larvae. Parasitoid species that reduce food consumption are less likely to be affected because they tend to shorten the life of the host and reach a life stage (i.e. form protective cocoons) in which insecticides may not kill them. Thus, the impact of parasitism on the host's feeding may affect plans for biological control introductions in integrated pest management (IPM) programs (Hunter and Stoner 1975). In this study we assessed the effect of parasitism by the native ichneumonid *B. flavescens*

and the exotic braconid *M. mediator* on *M. configurata* growth and food consumption.

## MATERIALS AND METHODS

Hosts used in the experiments were from a *M. configurata* colony maintained on artificial diet (Bucher and Bracken, 1976). Parasitoids used in the experiments were derived from populations collected in Saskatchewan, Canada (*B. flavescens*) and central Switzerland (*M. mediator*). The *B. flavescens* females used in the experiments were reared from overwintered cocoons collected in the spring and maintained at  $21 \pm 1^\circ\text{C}$  and 16:8 L:D. The *M. mediator* was maintained in laboratory culture on *M. configurata* (Arthur and Mason, 1986). All plants used were canola, *Brassica napus* L. variety Westar. All experimental individuals were maintained at  $21 \pm 1^\circ\text{C}$  and 16:8 L:D.

For each of the experimental trials (3 for *B. flavescens* and 4 for *M. mediator*), 30 2nd instar larvae from the same egg mass were selected. The larvae were divided into three groups of 10 and individuals of each group weighed. Whole canola leaves (approximately  $7 \times 6$  cm) clipped at the petiole from growth cabinet grown plants were used in all food offerings and dry weight determinations. Larvae of one group were placed in individual 52mm diameter  $\times$  21mm deep petri dishes containing a canola leaf on moistened filter paper in 45 mm diameter petri dishes. Larvae of a second group were individually parasitized (under observation) by *B. flavescens* or *M. mediator* and placed on canola leaves in the manner described above. The third group of larvae were individually weighed (wet weight) with a Mettler analytical balance (Model AG245), frozen, dried (48 h @  $60^\circ\text{C}$ ), and then individually weighed (dry weight). The larvae were weighed and given fresh leaves at intervals (2–4 day) during each trial. The fresh weight of each leaf disc was recorded before introduction into the petri dish. Fresh and dry weights (48 h @  $60^\circ\text{C}$ ) were re-

corded separately and dry weight ratios (dry weight  $\div$  initial fresh weight) were calculated. The frass produced by each larva was collected at the end of each feeding period and stored in a plastic petri dish. The pooled amount for the experimental period was dried (48 h @  $60^\circ\text{C}$ ) and weighed. Similarly the fresh:dry weight ratios were determined for all larvae after parasitoid egression for parasitized individuals and at pupation for non-parasitized larvae.

Nutritional indices were initially considered (Waldbauer 1968, Kogan 1986), but Schmidt and Reese (1986) pointed out that these indices can be misleading due to the error introduced during initial measurements of dry matter of the food source, quantity of food eaten, and the weight of feces produced. These errors accumulate and are amplified in the calculation of the nutritional indices (Raubenheimer and Simpson 1992). Van Loon (1991) describes more precise techniques including indigestible markers, elemental budgets, planimetry, and respirometry. Thus, we calculated only:

*Food consumption* (F) = [(Mean Dry Weight of Control Food Portions / Mean Wet Weight of Control Food Portions)  $\times$  Initial Wet Weight of Food Portions] – Dry Weight of Food Portions after feeding;

*Total Food Consumed* (TC) =  $i \Sigma F$ , where  $n$  is the number of feeding intervals (to parasitoid egression or host pupation);

*Total Dry Weight Produced* (DWT) = Dry Weight at host pupation or parasitoid egression (host + parasitoid) – Mean Dry Weight (of control group) at the beginning of the experiment.

The *B. flavescens* data were analysed using analysis of variance (Proc GLM, SAS 1992) to determine if parasitism significantly affected the variables measured. The effects of parasitism by *M. mediator* were so obvious that statistical analyses

Table 1. Mean value for development time (days)(DT), total dry weight (mg)(of pupa or parasite larva + larval skin produced)(DWT), total mg dry weight of frass produced (Frass), and total mg dry weight consumed (TC) for non-parasitized and *B. flavescens*-parasitized *M. configurata*.

Index	Trial #1		Trial #2		Trial #3		Pooled	
	NP	P	NP	P	NP	P	Mean	SEM
DT	21.4*	21	19.2	19.3	20.1	21	20.3	0.2
DWT	83.2	32.8 <sup>a</sup>	57.2	32.3 <sup>b</sup>	80.2	46.7 <sup>a</sup>	53.3	3.5
Frass	142.9	117.3	185	127.0 <sup>b</sup>	138	166.9	148.2	6.1
TC	415.3	318.9 <sup>c</sup>	406.5	228.4 <sup>b</sup>	371	297.6 <sup>c</sup>	334.9	12.6

\*approximate standard error of the mean for a trial mean can be obtained by multiplying the pooled SEM by 1.7. For each trial significant differences owing to parasitism are indicated by: <sup>a</sup> = ( $P < 0.001$ ), <sup>b</sup> = ( $P < 0.01$ ), <sup>c</sup> = ( $P < 0.1$ ).

were not necessary (a non-parametric test could have been used).

## RESULTS

*Banachus flavescens*.—In all experimental trials, nonparasitized (NP) *M. configurata* larvae consumed significantly more food and gained significantly more weight than did parasitized (P) larvae (Table 1). There was no significant difference in the number of days required to complete development. From the beginning of the trial it took *M. configurata* 18–24 days to develop to the pupal stage and development of *B. flavescens* from oviposition to larval egression was completed in 19–24 days. However, in spite of minor differences among trials on some dates, overall the only variable which showed a significant trial  $\times$  treatment interaction, that is differences in pattern from trial to trial, was the dry weight of frass produced.

While Fig. 1a and b are representative of the patterns observed in all three trials, owing to individual variability within trials (especially because some values were much higher or lower than all others in a group) differences in weight and food consumed by the parasitized and non-parasitized groups were not always consistent, on specific dates, from trial to trial. Consumption of food peaked at 14–18, 16–19 and 11–14 days in trials 1–3, respectively. Food consumption declined markedly after the peak, coinciding with the beginning of the prepupal stage in non-parasitized hosts and the pre-emergence period of the parasitoid.

*Microplitis mediator*.—In all experimental trials non-parasitized (NP) *M. configurata* larvae consumed dramatically more food, gained much more weight and produced much more frass than did parasitized (P) larvae (Table 2). Feeding and develop-

Table 2. Mean value for development time (DT), total dry weight (of pupa or parasite larva + larval skin produced (DWT)), total mg dry weight of frass produced (Frass), and total mg dry weight consumed (TC) for non-parasitized and *M. mediator*-parasitized *M. configurata*.

Index	Trial #1		Trial #2		Trial #3		Trial #4		Pooled SE	
	NP	P	NP	P	NP	P	NP	P	NP	P
DT	21	12	21	11.4	21	12.3	21	11	0	0.2
DWT	67.6	2.8	62.4	1	77.8	3.8	81.2	2.6	4.2	0.02
Frass	182.6	5.1	209	4.5	161	7	213	12.7	8.3	0.1
TC	402	13	593	82	294	31	356	47.6	26.1	13.9

\*approximate standard error of the mean for a trial mean can be obtained by multiplying the pooled S.E.M. by 2.0.

ment to the pupal stage of non-parasitized *M. configurata* reared from neonate larvae at  $21 \pm 1^\circ\text{C}$  takes 21–25 days (unpublished data). Parasitized larvae ceased to consume food, once *M. mediator* larvae egressed and formed cocoons (11–14 days after parasitism), a markedly shorter period than the food consumption period for non-parasitized *M. configurata* larvae.

Non-parasitized larvae weighed and consumed significantly more beginning 4–8 and 8–11 days, respectively, after trials were initiated. The trends represented in Figure 2a and b for trial #1 were typical. For non-parasitized larvae consumption of food and larval weights peaked 15–17, 13–15, 11–13, and 13–15 days after parasitism in trials 1–4, respectively. Both consumption and weight declined after this peak, coinciding with the beginning of the prepupal stage. For parasitized larvae, larval weight did not increase beginning 4–8 days after the trials were initiated. Food consumption showed only a small increase in trial #2, while actually decreasing in the other three trials beginning 0–4 days after trials were initiated. In all trials food consumption by parasitized larvae ceased by day 13, 7 days before non-parasitized larvae ceased feeding.

## DISCUSSION

Synchronization of the completion of larval development of *B. flavescens* and *M. configurata* is consistent with results by Slovak (1987) for another Banchini, *Exestastes cinctipes* Retzius (Hymenoptera: Ichneumonidae), parasitizing *M. brassicae*. He found that at  $20^\circ\text{C}$  development to parasitoid cocoon formation took 25.3–26.6 days while non-parasitized larvae took 26.4–26.7 days to form pupae. These development times are 5–6 days longer than those we observed at  $21.0 \pm 1.0^\circ\text{C}$  for *B. flavescens* parasitizing *M. configurata*. Slovak (1987) also noted that at 20 or  $24^\circ\text{C}$  parasitized host larvae entered the soil significantly earlier (2.1–3.0 and 3.5–3.9 days, respectively) than non-parasitized

larvae. Although we did not study this behaviour, it may also occur in the *B. flavescens*/*M. configurata* parasitoid/host system because, as reported by Arthur and Mason (1985), the parasitoid forms a cocoon in which it overwinters within the earthen cell formed by the host larva just before being killed.

That parasitism by *B. flavescens* significantly reduced the total amount of food consumed by *M. configurata* (20–44%) is reflected in the fact that parasitized larvae produced significantly less (39.4–58.2%) dry protein matter than non-parasitized larvae. Although not directly comparable, these results are similar to findings for solitary koinobiont Campoplegine species attacking Lepidoptera (Khan 1994, Kumar and Ballal 1992, Yang *et al.* 1994, Doucet and Cusson 1996). Only Doucet and Cusson (1996) measured frass production, and found that non-parasitized larvae produced 38% more frass than parasitized larvae. In contrast, about 10% more frass was produced by non-parasitized than parasitized larvae in two of three trials and 10% less in the third trial in our study. It is not clear why frass production by parasitized larvae in one of our three trials was greater than for nonparasitized larvae.

Development of *M. mediator* to egression took 11–14 days, about 1/3 less time than for *B. flavescens*. Egression of mature *M. mediator* larvae occurs just after the host molts to the 4<sup>th</sup> larval instar even if parasitized in the 3<sup>rd</sup> instar and, as noted by Shaw and Huddelston (1991) for other *Microplitis* spp., the cocoon is formed beneath the host which remains alive for several days without feeding (Mason, unpublished). Behavioral modification of *M. configurata* hosts by mature larval *M. mediator* parasitoids has been observed in the laboratory (Pivnick 1993). Parasitized host larvae moved to the leaf litter and senescent leaves that become part of the litter where parasitoid pupation took place. This was confirmed in the field where cocoons successfully overwintered (Mason,

unpublished). In both situations very few parasitoid cocoons were found on standing plant parts that are harvested.

Parasitism of *M. configurata* by *M. mediator* clearly had a greater impact on the amount of food consumed by the host than parasitism by *B. flavescens* (Figs. 1b and 2b). The results observed for *M. mediator* are consistent with those observed for solitary koinobiont Microgastrinae Braconidae parasitoids attacking Lepidoptera in other systems (Rahman 1970, Sajap *et al.* 1978, Parkman and Shepard 1981, Tanaka *et al.* 1984, Powell 1989). In contrast, Lepidopteran hosts parasitized by at least some gregarious koinobiont Braconidae and polyembryonic Encyrtidae species consume significantly more than non-parasitized hosts and take longer to develop (Rahman 1970, Hunter and Stoner 1975, Gobbi *et al.* 1993, Byers *et al.* 1993).

The decrease in feeding and weights after a maximum peak is reached (Figs. 1 and 2) is linked to cessation of feeding and gut evacuation associated with prepupal development in non-parasitized larvae, and probably to cessation of feeding by parasitized larvae which move to the leaf litter (*M. mediator*, see Pivnick 1993) or form earthen cells (*B. flavescens*, see Arthur and Mason 1985) where they complete development and pupate. The different times to peak weights and consumption between trials may be related to differences in food quality, although the same plant variety, growing conditions, and leaf type were used in each trial. Genetic differences between cohorts of *M. configurata* and/or the parasitoid species may also have caused this variation.

The variability (i.e. large standard errors) observed, particularly on measurements made on day 13 or later (Figs. 1 and 2), may be associated with unexplained mortality during the experiments, differences between sexes, or stochastic effects because of the relatively small numbers of experimental individuals (n ranged from 5–9 and 7–9 for non-parasitized and par-

asitized hosts in the *B. flavescens* trials and from 10 and 4–9 for non-parasitized and parasitized hosts in the *M. mediator* trials). The genetic diversity of individuals (even though hosts were from the same egg mass and parasitoids from the same female) may have also been a factor.

Natural controls, including parasitoids, have a major impact on bertha armyworm populations (Mason *et al.* 1998) and IPM programs should be developed around them. Chemical insecticides are used when 5<sup>th</sup> and 6<sup>th</sup> instar larvae are present on ripening canola pods (their feeding accounting for more than 86% of total larval consumption). Wylie and Bucher (1977) reported that *B. flavescens*, like bertha armyworm, is univoltine. Although *M. mediator* is bivoltine through most of its range in Eurasia where *M. brassicae* is also bivoltine, Johansen (1997) found it in a univoltine *M. brassicae* population in Norway (although Pivnick [1993] showed that *M. mediator* will diapause, further study is needed to determine if it would be univoltine on bertha armyworm). Adult *B. flavescens* and *M. mediator* are not likely to be affected by current chemical control practices because they attack early (1<sup>st</sup> to 3<sup>rd</sup>) instar larvae and would disappear from the crop before 5<sup>th</sup> and 6<sup>th</sup> instar larvae are present. Even if *M. mediator* proves to be bivoltine in western Canada adults would probably move out of the canola crop seeking alternate hosts in adjacent habitats because no bertha armyworm in the appropriate stages would be available.

Bertha armyworm larvae parasitized by *B. flavescens* feed until they reach the 6<sup>th</sup> instar; thus the parasitoid would be negatively impacted by insecticides because the susceptible host is present in the crop being sprayed. Also, the parasitized larvae continue to feed (causing crop damage) during pod development and the benefits of parasitism by *B. flavescens* are only evident the following year. In contrast, *M. configurata* larvae parasitized by *M. mediator* have ceased to feed (and consumed

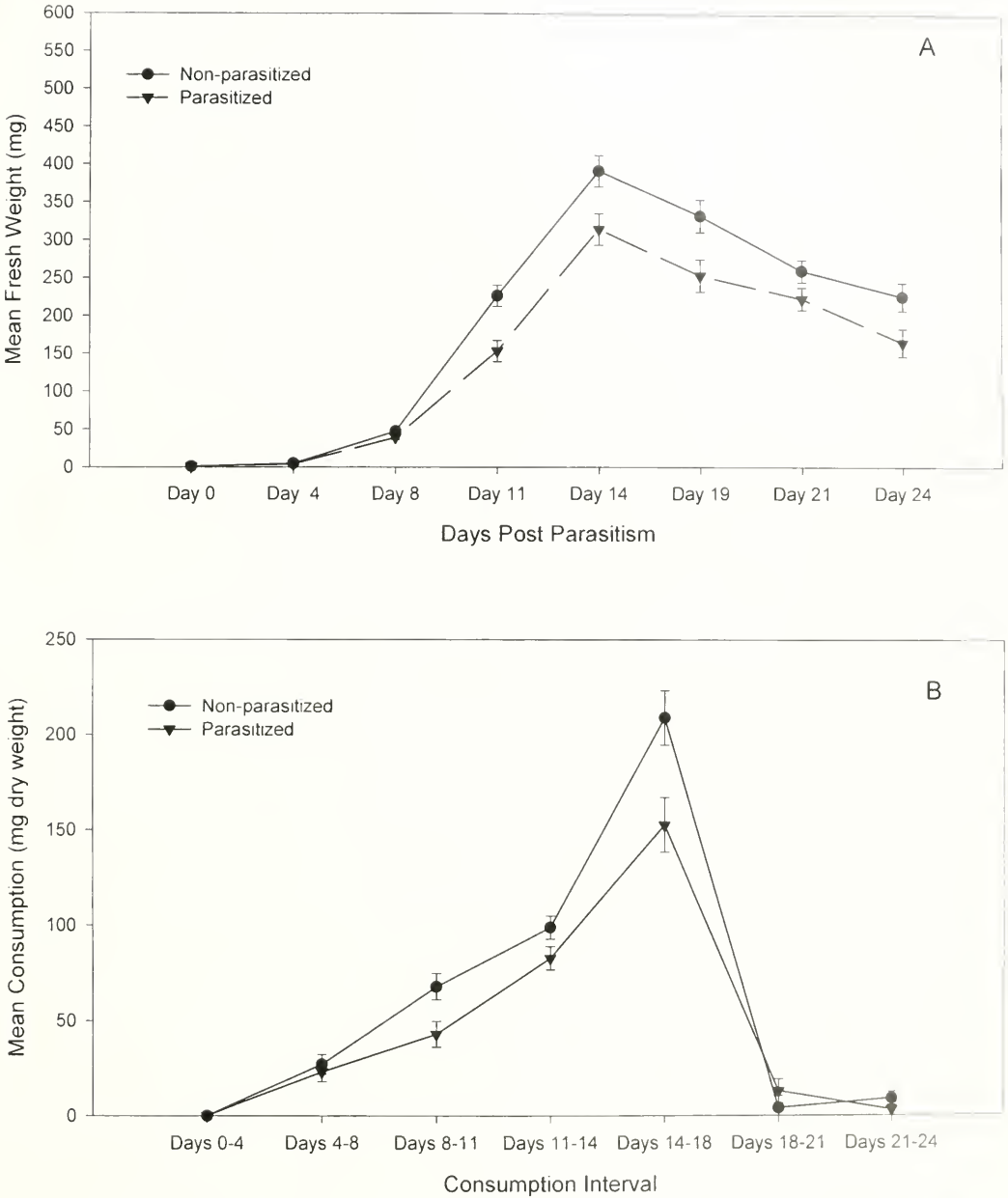

Fig. 1. Effect of parasitism (Trial #1) by *B. flavescens* on *M. configurata*: a) Mean fresh weight ( $\pm$ SEM) of parasitized and non-parasitized *Mamestra configurata* larvae; b) Mean food consumption ( $\pm$ SEM) by parasitized and non-parasitized *Mamestra configurata* larvae.

<20% of the total consumption of non-parasitized larvae) by the time non-parasitized 4<sup>th</sup> instar larvae are present, before the switch to feeding on canola pods by later instar larvae. Further, *M. mediator* have formed cocoons and would likely be

only minimally affected by insecticides used on 5<sup>th</sup> and 6<sup>th</sup> instar *M. configurata*, although this needs to be confirmed. Therefore, *M. mediator* appears to be a good candidate agent for use in the IPM of *M. configurata* because: 1) damage to the

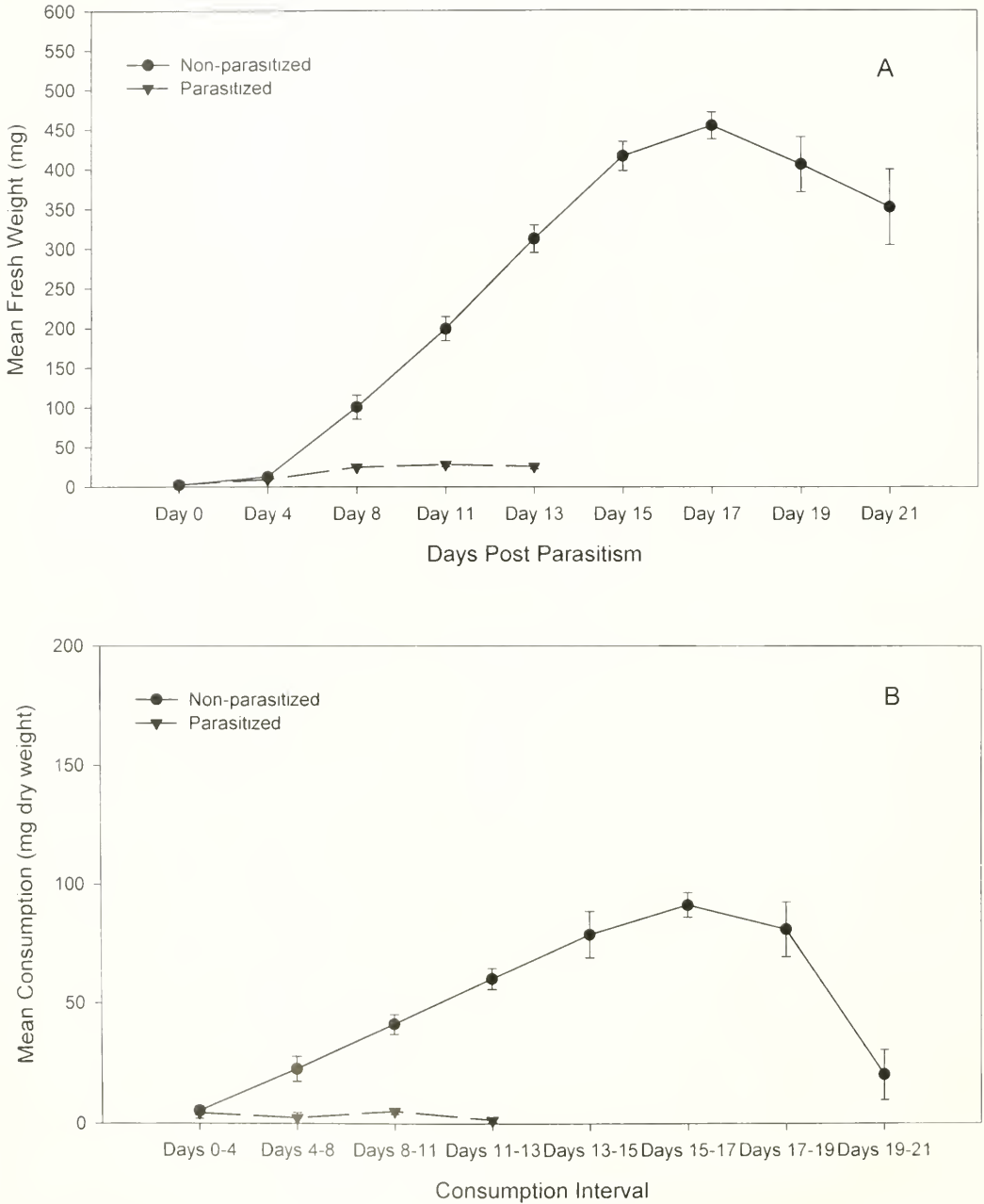

Fig. 2. Effect of parasitism (Trial #1) by *M. mediator* on *M. configurata*: a) Mean fresh weight ( $\pm$ SEM) of parasitized and non-parasitized *Mamestra configurata* larvae; b) Mean food consumption ( $\pm$ SEM) by parasitized and non-parasitized *Mamestra configurata* larvae.

host plant by parasitized larvae occurs when foliage is abundant and ceases before pod development begins; and 2) it should be compatible with other control

agents such as chemical or biological insecticides targeted at 4<sup>th</sup> to 6<sup>th</sup> instar bertha armyworm which are applied after *M. mediator* has eliminated a portion of the pest

population. Caged field release studies are needed to verify these hypotheses.

The results obtained in this study suggest that for *M. configurata* parasitism by *B. flavescens* results in significantly decreased consumption of food (and probably less damage to canola crops) resulting in lower biomass production but does not reduce the length of time that the pest feeds in the crop and parasitism by the braconid *M. mediator* causes a significant reduction in the amount of food consumed and the length of time the host feeds compared to non-parasitized *M. configurata*. Parasitism and the findings presented here should be taken into consideration when developing integrated pest management strategies for the bertha armyworm.

#### ACKNOWLEDGEMENTS

We thank Jennifer Prins for technical assistance. B. Thompson provided helpful statistical advice. L. Braun and U. Kuhlmann provided helpful comments of an earlier draft of the manuscript.

#### LITERATURE CITED

- Arthur, A. P. and P. G. Mason. 1985. Life history and immature stages of *Banchus flavescens* (Hymenoptera: Ichneumonidae), a parasitoid of the bertha armyworm, *Mamestra configurata* (Lepidoptera: Noctuidae) in western Canada. *The Canadian Entomologist* 117: 1249–1255.
- Arthur, A. P. and P. G. Mason. 1986. Life History and immature stages of the parasitoid *Microplitis mediator* (Hymenoptera: Braconidae), reared on the bertha armyworm *Mamestra configurata* (Lepidoptera: Noctuidae). *The Canadian Entomologist* 118: 487–491.
- Askew, R. R. and M. R. Shaw. 1986. Parasitoid communities: their Size, Structure and Development. pp. 225–264. In: Waage, J. and D. Greathead (eds.) *Insect Parasitoids*. Academic Press, London.
- Brewer, F. D. and E. G. King. 1978. Effects of parasitism by a tachinid, *Lixophaga diatraeae*, on growth and food consumption of sugarcane borer larvae. *Annals of the Entomological Society of America* 71: 19–22.
- Brewer, F. D. and E. G. King. 1980. Consumption and utilization of a soyflour-wheat germ diet by larvae of the tobacco budworm parasitized by the tachinid *Eucelatoria* sp. *Entomophaga* 25: 95–101.
- Brewer, F. D. and E. G. King. 1981. Food consumption and utilization by sugarcane borers parasitized by *Apanteles flavipes*. *Georgia Entomological Society* 16: 185–192.
- Bucher, G. E. and G. K. Bracken. 1976. The bertha armyworm, *Mamestra configurata* (Lepidoptera: Noctuidae). Artificial diet and rearing technique. *The Canadian Entomologist* 108: 1327–1338.
- Byers, B. R., D. S. Yu and J. W. Jones. 1993. Parasitism of the army cutworm, *Euxoa auxiliaris* (Grt.) (Lepidoptera: Noctuidae), by *Copidosoma bakeri* (Howard) (Hymenoptera: Encyrtidae) and effect on crop damage. *The Canadian Entomologist* 125: 329–335.
- Doucet, D. and M. Cusson. 1996. Alteration of developmental rate and growth of *Choristoneura fumiferana* parasitized by *Tranosema rostrale*: role of the calyx fluid. *Entomologia Experimentalis et Applicata* 81: 21–30.
- Erlandson, M. A. 1990. Biological and biochemical comparisons of *Mamestra configurata* and *Mamestra brassicae* NPV isolates pathogenic for *Mamestra configurata* (Lepidoptera: Noctuidae). *Journal of Invertebrate Pathology* 56: 47–56.
- Gobbi, N., J. Chaud-Netto, J. A. F. Diniz-Filho, S. M. T. Tornisielo, L. C. Almeida and S. L. Nazareth. 1993. Study of the relationship between *Cotesia flavipes* (Cameron, 1891) and *Diatraea saccharalis* (Fabricius, 1794). I. Effect of parasitism on food consumption of fourth instar larvae. *Naturalia, São Paulo* 18: 201–206.
- Guillot, F. S. and S. B. Vinson. 1973. Effect of parasitism by *Cardiochiles nigriceps* on food consumption and utilization by *Heliothis virescens*. *Journal of Insect Physiology* 19: 2073–2082.
- Harvey, J. A. 1996. *Venturia caescens* parasitizing *Galleria mellonella* and *Anagasta kuehniella*: is the parasitoid a conformer or a regulator? *Journal of Insect Physiology* 42: 1017–1025.
- Hunter, K. W. and A. Stoner. 1975. *Copidosoma truncatellum*: effect of parasitization on food consumption of larval *Trichoplusia ni*. *Environmental Entomology* 4: 381–382.
- Johansen, N. S. 1997. Mortality of eggs, larvae and pupae and larval dispersal of the cabbage moth, *Mamestra brassicae*, in white cabbage in south-eastern Norway. *Entomologia Experimentalis et Applicata* 83: 347–360.
- Kogan, M. 1986. Bioassays for measuring quality of insect food. pp155–189. In: Miller, J. R. and T. A. Miller (eds), *Insect-Plant Interactions*. J.R. Springer-Verlag, New York.
- Khan, S. M. 1994. Food consumption and utilization of *Agrotis segetum* larvae parasitized by *Meloboris collector*. *Sarhad Journal of Agriculture* 10: 187–189.
- Kumar, P. and C. R. Ballal. 1992. The effect of parasitism by *Hyposoter didymator* (Hymenoptera: Ichneumonidae) on food consumption and utilization by *Spodoptera litura* (Lepidoptera: Noctuidae). *Entomophaga* 37: 197–203.

- Mason, P. G., A. P. Arthur, O. O. Olfert and M. A. Erlandson. 1998. The bertha armyworm (*Mamestra configurata*) (Lepidoptera: Noctuidae) in western Canada. *The Canadian Entomologist* 130: 321–336.
- Ohnuma, Y. and Y. Kainoh. 1992. Effect of parasitism by *Ascogaster reticulatus* (Hymenoptera: Braconidae) on growth of the host, *Adoxophyes* spl. (Lepidoptera: Tortricidae). *Entomophaga* 37: 327–332.
- Parkman, P. and M. Shepard. 1981. Foliage consumption by yellowstriped armyworm larvae after parasitization by *Euplectrus plathyepena*. *Florida Entomologist* 64: 192–194.
- Pivnick, K. 1993. Diapause initiation and pupation site selection of the braconid parasitoid *Microplitis mediator* (Haliday): A case of manipulation of host behaviour. *The Canadian Entomologist* 125: 825–830.
- Powell, J. E. 1989. Food consumption by tobacco budworm (Lepidoptera: Noctuidae) larvae reduced after parasitization by *Microplitis demolitor* or *M. croceipes* (Hymenoptera: Braconidae). *Journal of Economic Entomology* 82: 408–411.
- Quicke, D. L. J. 1997. *Parasitic Wasps*. Chapman & Hall, London. 470 p.
- Rahman, M. 1970. Effect of parasitism on food consumption of *Pieris rapae* larvae. *Journal of Economic Entomology* 63: 820–821.
- Raubenheimer, D. and S. J. Simpson. 1992. Analysis of covariance: an alternative to nutritional indices. *Entomologia Experimentalis et Applicata* 62: 221–231.
- Sajap, A. S. B., C. C. Beegle and L. C. Lewis. 1978. Effect of parasitism by *Microplitis kewleyi* on the cutting ability of its host *Agrotis ipsilon*. *Environmental Entomology* 7: 343–344.
- SAS Institute. 1992. SAS technical report P-229, SAS/STAT software: changes and enhancements, release 6.07. SAS Institute, Cary, N.C.
- Schmidt, D. J. and J. S. Reese. 1986. Sources of error in nutritional index studies of insects on artificial diets. *Journal of Insect Physiology* 32: 193–198.
- Shaw, M. R. 1981. Delayed inhibition of host development by the nonparalyzing venoms of parasitic wasps. *Journal of Invertebrate Pathology* 37: 215–221.
- Shaw, M. R. and T. Huddleston. 1991. Classification and Biology of Braconid Wasps (Hymenoptera: Braconidae). *Handbooks for the Identification of British Insects* 7(11): 1–126.
- Slovak, M. 1985a. Studies on morphology and development of the immature stages of *Microplitis mediator* Hal. (Hymenoptera: Braconidae). *Biológia* 40: 529–538.
- Slovak, M. 1985b. Biological observations on *Microplitis mediator* Hal. (Hymenoptera: Braconidae). *Biológia* 40: 987–996.
- Slovak, M. 1987. Influence of temperature and hosts nutritional conditions on development of the immature stages of *Exestastes cinctipes* Retz. (Hymenoptera: Ichneumonidae). *Biológia* 42: 587–596.
- Tanaka, T., Y. Sato and T. Hidaka. 1984. Developmental interaction between *Leucania separata* (Lepidoptera: Noctuidae) and its braconid parasitoid, *Microplitis mediator* (Hymenoptera: Braconidae). *Journal of Economic Entomology* 77: 91–97.
- Turnock, W. J. 1988. Density, parasitism, and disease incidence of larvae of the bertha armyworm, *Mamestra configurata* Walker (Lepidoptera: Noctuidae), in Manitoba, 1973–1986. *The Canadian Entomologist* 120: 401–413.
- Turnock, W. J. and R. J. Bilodeau. 1984. Survival of pupae of *Mamestra configurata* (Lepidoptera: Noctuidae) and two of its parasites in tilled and untilled soil. *The Canadian Entomologist* 116: 257–267.
- Van Loon, J. J. A. 1991. Measuring food utilization in plant-feeding insects—towards a metabolic and dynamic approach. pp. 79–124. In: Bernays, E. A. (ed), *Insect-Plant Interactions*. Vol. 3. CRC Press Boca Raton, FL.
- Waldbauer, G. P. 1968. The consumption and utilization of food by insects. *Advances in Insect Physiology* 5: 229–288.
- Wylie, H. G. 1977. Observations on *Athrycia cinerea* (Diptera: Tachinidae), a parasite of *Mamestra configurata* (Lepidoptera: Noctuidae). *The Canadian Entomologist* 109: 747–754.
- Wylie, H. G. and G. E. Bucher. 1977. The bertha armyworm, *Mamestra configurata* Walker (Lepidoptera: Noctuidae), mortality of immature stages on the rape crop 1972–1975. *The Canadian Entomologist* 109: 823–837.
- Yang, J., Y. Chu and N. S. Talekar. 1994. Studies on the characteristics of parasitism of *Plutella xylostella* (Lepidoptera: Plutellidae) by a larval parasite *Diadegma semiclausum* (Hymenoptera: Ichneumonidae). *Entomophaga* 39: 397–406.

## Natural Alternative Hosts of Eulophidae (Hymenoptera: Chalcidoidea) Parasitoids of the Citrus Leafminer *Phyllocnistis citrella* Stainton (Lepidoptera: Gracillariidae) in the Mediterranean Basin

BRUNO MASSA, MARIA CONCETTA RIZZO, AND VIRGILIO CALECA

Istituto di Entomologia agraria, Università degli Studi di Palermo, Viale delle Scienze 13,  
90128 Palermo, Italy. E-mail: zoolappl@unipa.it

---

*Abstract.*—The entomofauna linked to native flora in and around citrus groves was studied in Italy and Jordan in order to find alternative hosts of eulophid parasitoids of the Citrus Leafminer (CLM), *Phyllocnistis citrella* Stainton (Lepidoptera: Gracillariidae). Twenty new associations (12 in Italy, 8 in Jordan) among native and exotic CLM parasitoids and leafminers were found. Two new alternative hosts were recorded for *Citrostichus phyllocnistoides* (Narayanan) (an unidentified Nepticulidae on *Pistacia lentiscus* L. and *Stigmella* sp. on *Rubus ulmifolius* Schott, in Sicily and Jordan respectively) and 1 for *Cirrospilus ingenuus* Gahan (Agromyzidae on *Salix* sp., in Jordan). Five new alternative hosts were recorded for *Semielaecher petiolatus* (Girault) (in Sicily *Liriomyza* sp. on *Mercurialis annua* L., *Chromatomyia horticola* (Goureau) on *Sonchus* spp., *Cosmopterix pulchrimella* Chambers on *Parietaria diffusa* M. et K., and *Stigmella aurella* (Fabr.) on *Rubus ulmifolius* Schott; in Jordan, *Dialectica scalarisella* Zeller on *Echium* sp.). The other 12 new associations of CLM parasitoids with leafminers found in both countries include *Neochrysocharis formosa* (Westwood) (4 new hosts), *Cirrospilus variegatus* (Masi) (5 new hosts), *Ratzeburgiola incompleta* Bouček (1 new host), *Ratzeburgiola cristata* (Ratzeburg) (1 new host), and *Asecodes delucchii* (Bouček) (1 new host). Data reported here suggest that native vegetation harbours alternative hosts for both native and exotic parasitoids. They also underline that more attention should be paid to the understanding of ecology and biology of parasitoid species in order to use appropriate exotic enemies in biological control, preserving at the same time indigenous parasitoid communities.

---

The Citrus Leafminer (CLM), *Phyllocnistis citrella* Stainton (Lepidoptera: Gracillariidae), is presently considered to be a serious threat to young citrus trees in the Mediterranean region and other countries, where it has expanded its range in the last seven years. The CLM attacks new leaves causing a loss of photosynthetic area. *Semielaecher petiolatus* (Girault), *Citrostichus phyllocnistoides* (Narayanan) and *Cirrospilus ingenuus* Gahan (Hymenoptera: Eulophidae) are considered among dominant natural enemies of CLM in its original range (India and South Asia) and in Australia (Smith *et al.* 1997, Schauff *et al.* 1998). Eulophid parasitoids have been selected for biological control programmes against

CLM in many countries and in some case also have been recovered in neighbouring countries (Schauff *et al.* 1998).

Native plants are an important source of biological diversity in agroecosystems and are known to harbour natural enemies of phytophagous pests of cultivated plants, supplying alternative food, refuges and hosts (McMurtry and Johnson 1965, Powell 1986, Altieri 1991, Ragusa Di Chiara 1991). They provide a diverse source of food for many species of polyphagous natural enemies, which in turn may parasitize phytophagous insects of cultivated plants in seasons when they are abundant.

Studies of phytophagous insects are often directed at species attacking cultivated

plants and, less so, species feeding on native ones; thus our knowledge of the hosts of parasitoids on cultivated plants is extensive, whereas we have only scattered data on the alternative hosts available to these parasitoids on native plants. Preservation of these reservoirs of antagonists may prove valuable when parasitoids utilize hosts that are not pests of cultivated plants, and when biological control depends on multiple natural enemy species, as in the case of the CLM.

The present study is part of a research project examining the entomofauna of native flora carried out in 11 citrus orchards of Sicily (Italy), the results of which were partly published (Caleca *et al.* 1997, Mineo *et al.* 1997a, 1997b, Caleca 1998, Caleca *et al.* 1998, Mineo and Sinacori 1998, Rizzo *et al.* 1999, Massa and Rizzo 2000). Some new findings are presented that highlight interesting relationships between CLM parasitoids and their non-pest hosts exploiting native plants.

#### MATERIALS AND METHODS

Native floras associated with citrus groves in Sicily (Italy) have been studied in detail by Raimondo *et al.* (1979); they amount to about 200 species involving mainly herbs and shrubs. During the four years of our research project (1997–2000), we collected about 40 of the most common species belonging to this flora, and about 10 belonging to riverine flora sometimes occurring in the neighbouring areas of citrus orchards in Sicily. About 250 g of each plant species were collected monthly along at least two perpendicular transects inside 11 citrus groves and along their perimeter. Leaves infested by miners were placed in Petri dishes with wet paper at 25° C, 65% r.h. and L14:D10. All phytophagous species and parasitoids that emerged were mounted and identified. Further samples were gathered by the senior author during a research trip to Jordan between 21 and 29 May 1999 in the

following localities: Al Bahhath (Amman), Aqaba and Dana Village.

#### RESULTS

In Sicily, 40 host-parasitoid associations involving phytophages of native plants and antagonists of CLM were already known (Caleca *et al.* 1997, Mineo *et al.* 1997a, 1997b, Caleca 1998, Caleca *et al.* 1998, Mineo and Sinacori 1998, Rizzo *et al.* 1999, Massa and Rizzo 2000). They are listed in Fig. 1 together with the 12 (Italy) and 8 (Jordan) associations, previously unnoticed, recorded in the present paper. Data for new records are reported in Table 1.

The parasitoids we found on indigenous leafminers belong to two quite different kinds: exotic CLM biological control agents (i.e., *Semiela cheri*, *Citrostichus phyllocnistoides* and *Cirrospilus ingenuus*), which possibly have switched over onto indigenous hosts after their introduction or immigration, and native parasitoids, which in turn have switched over onto the invading CLM. Among the latter, some (i.e., *Neochrysocharis formosa* (Westwood), *Ratzeburgiella incompleta* Bouček and *Pnigalio soemius* (Walker)) are quite common on indigenous hosts in Sicily (Fig. 1a), while three of them (i.e., *Diglyphus isaea* (Walker), *Ratzeburgiella cristata* (Ratzeburg) and *Cirrospilus variegatus* (Masi)) have not yet been recorded on CLM in the island, although they have been reported on this host in other countries (Schauff *et al.* 1998). It should be pointed out that, even if their parasitization does not always reach relevant values, most CLM parasitoids engage in host-feeding which contributes additional mortality. For example in Algeria Guenaoui and Dahliz (1997) attributed as much as 20–50% of CLM larval mortality to host-feeding and in Sicily it may approach 15% (pers. obs.).

Among the eight new host-parasitoid associations reported from Jordan (Fig. 1b), five concern eulophids (*S. petiolatus*, *N. formosa*, *C. phyllocnistoides* and *C. ingenuus*)

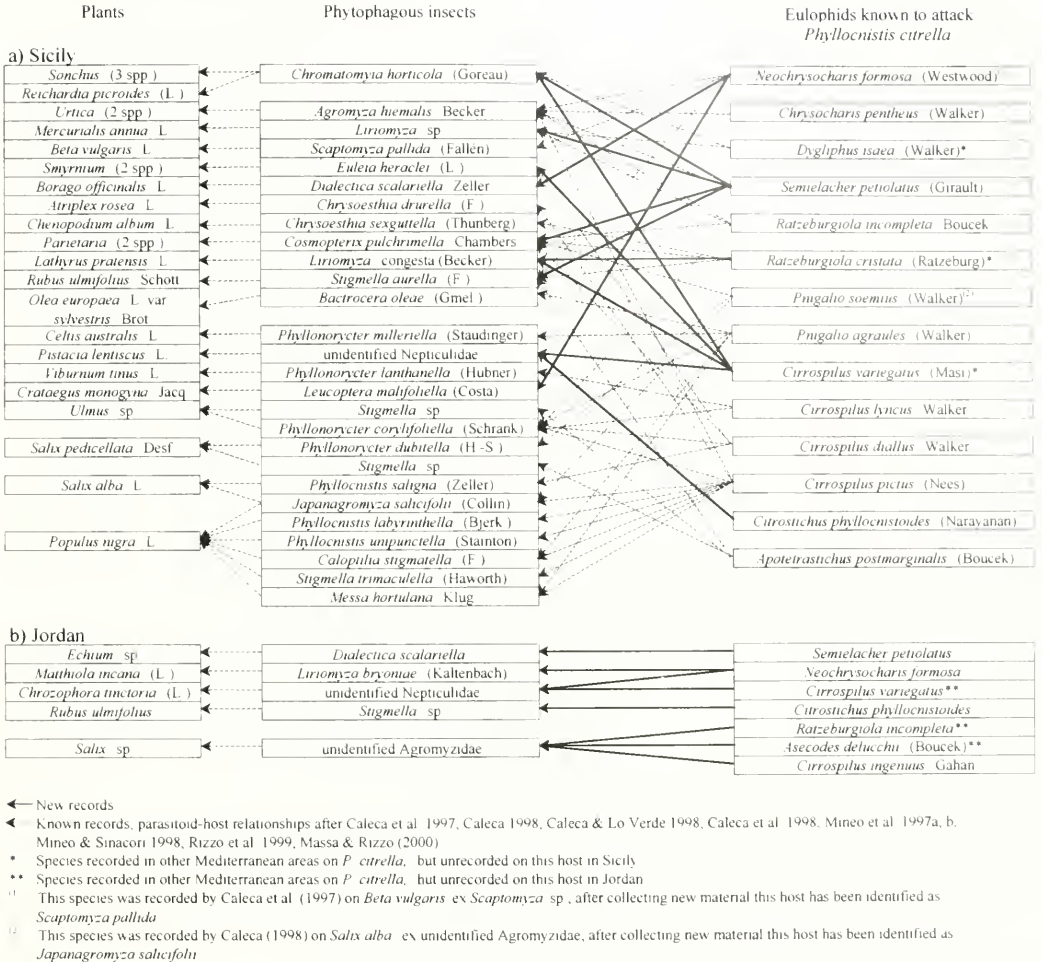

Fig. 1. Associations between eulophid parasitoids of *Phyllocnistis citrella* and other phytophagous insects exploiting native plants in citrus groves in Sicily, Italy (a) and Jordan (b).

known to attack CLM in the country (Schauff et al. 1998, Mineo 1999). *C. variegatus*, *R. incompleta* and *A. delucchii* (Bouček) have been recorded as CLM parasitoids in other countries of the Mediterranean Basin, but until now have been found only on native plants in Jordan, although this may be due to the paucity of information on CLM in this country. Some details on the new findings are reported below.

*Semiela cher petiolatus* (Girault)

Originally described from Australia, *S. petiolatus* has also been reported from the

Solomon Islands (Bouček 1988, Schauff et al. 1998). It was introduced to Oman, Syria, Israel, Egypt, Cyprus, Greece, Turkey, Tunisia and Morocco (Michelakis 1997, Argov and Rössler 1996, FAO 1996, Nia et al. 1997, Rössler and Argov 1997, Hamed et al. 1999); it spread spontaneously in Italy, Algeria and Jordan (Mineo et al. 1998, Schauff et al. 1998, Mineo 1999). Before being reared from *Agromyza hiemalis* Becker (Diptera: Agromyzidae) (Massa and Rizzo 2000), the only host previously known for this species was the CLM (Schauff et al. 1998), and, from 1998 onwards, it became one of the most important parasitoids of

this pest in Sicily (Caleca *et al.* 1998, Mineo and Mineo 1999a). The five new hosts listed in this paper (Table 1), comprising three Lepidoptera (Cosmopterigidae, Nepticulidae and Gracillariidae) and two Diptera (Agromyzidae), are widespread in the Mediterranean region.

It should be noted that this species appeared in Sicily on *Chromatomyia horticola* (Goureau) (Diptera: Agromyzidae) about one year after its release in 1996 in Tunisia (FAO 1996). The availability of alternative hosts that provide refuge and food for *S. petiolatus* during seasons of low CLM population density, could partly explain the quick spread and establishment of this species, both in countries where it has been released and in neighbouring sites (Caleca *et al.* 1998, Schauff *et al.* 1998, Mineo and Mineo 1999a).

#### *Citrostichus phyllocnistoides* (Narayanan)

This species is known from Afghanistan, China, India, Indonesia, Japan, Oman, Pakistan, Taiwan, Thailand, South Africa, Sudan, Swaziland (Bouček 1988, FAO 1996, Schauff *et al.* 1998), and has been introduced to Cyprus, Greece and Italy (Sicily) (Michelakis 1997, FAO 1996, Mineo and Mineo 1999b), and Australia and Israel (where it is not considered established) (Smith *et al.* 1997, Argov and Rössler 1996). It probably spread to Jordan from Israel (Mineo 1999). Although recorded as a parasitoid of the CLM (Bouček 1988, Ujiye and Adachi 1995, Wu and Lin 1998), it also has been reported to parasitize the nymphs of *Trioza obsoleta* Buckton (Homoptera: Psyllidae) a gall former on *Diospyros melanoxylon* (Roxb.) (Dash and Das 1997). Our records concern two additional Lepidoptera (Table 1); according to Nieukerken (pers. comm.) the mines on *Rubus ulmifolius* Schott found in Jordan belong to a *Stigmella* species (Nepticulidae), possibly *Stigmella aurella* (Fabr.), a previously unrecorded host for this parasitoid.

#### *Cirrospilus ingenuus* Gahan

Also known as its synonym *C. quadris-triatus* (Subba Rao and Ramamani), this species has been recorded from Australia, China, India, Indonesia, Japan, Malaysia, Oman, Taiwan, Thailand (Smith *et al.* 1997, Schauff *et al.* 1998), and introduced to Cyprus, Turkey, Israel, Syria, Egypt, Tunisia, Morocco, Florida and Mexico (Argov and Rössler 1996, FAO 1996, Perales-Gutierrez *et al.* 1996, Hamed *et al.* 1999, LaSalle *et al.* 1999). It has also spread to Jordan and North Egypt, probably from other countries of the Mediterranean Basin (Schauff *et al.* 1998). It is generally considered to be a dominant parasitoid of *P. citrella* (e.g., Thailand, Taiwan and Japan: Ujiye *et al.* 1996), but also has been recorded as a parasitoid of *Rhynchaenus mangiferae* Marshall (Coleoptera: Curculionidae) in India (Peter and Balasubramanian 1984). Agromyzidae previously has not been recorded as a host for this parasitoid.

#### *Cirrospilus variegatus* (Masi)

Also known as its synonym *Zagrammosoma variegatum*, it occurs in the Mediterranean Region, North and East Africa, Central and South Asia, West Indies (Barbados), Australia and New Zealand (Bouček 1988; Yefremova 1996). This species was described from Italy by Masi (1907), as parasitoid of *Metriochoa latifoliella* (Millière) (Lepidoptera: Gracillariidae). It is also known to parasitize many species of small leaf-mining Lepidoptera (Bouček 1988, Yefremova 1996) and the CLM in Libya, Spain and Turkey (Schauff *et al.* 1998). During this study it was found on two Nepticulidae leafminers and on three Diptera (one Tephritidae and two Agromyzidae) (Table 1), all previously unrecognized as hosts.

#### *Ratzeburgiola incompleta* Bouček

Recorded from central Europe and many countries of the Mediterranean Ba-

Table 1. List of new host records for Eulophidae emerged from leafminers reared from native plants collected in Italy and Jordan.

Eulophid	Host species	Host plant	Data	Sex
<i>Semiolachet petiolatus</i> (Girault)	<i>Chromatomyia horticola</i> (Goureaux) (Diptera: Agromyzidae)	<i>Sonchus</i> spp.	Italy, Parco d'Orléans (Palermo) 3.V.97, 21.III.99	2♂
	<i>Liriomyza</i> sp. (Diptera: Agromyzidae)	<i>Mercurialis annua</i> L.	Italy, Borgo Molara (Palermo) 29.XI.98	1♀
	<i>Cosmopterix pulchrimel- la</i> Chambers (Lepi- doptera: Cosmopter- igidae)	<i>Parietaria diffusa</i> M. and K.	Italy, Zucco (Palermo) 6.VI.00, Borgo Mo- lara 26.I.99, 14.III.99	4♀
	<i>Stigmella aurella</i> (Fabr.) (Lepidoptera: Nepti- culidae)	<i>Rubus ulmifolius</i> Schott	Borgo Molara 17.VIII.99, Parco d'Orléans 20.IX.99	1♀
	<i>Dialectica scalariella</i> Zeller (Lepidoptera: Gracillariidae)	<i>Echium</i> sp.	Jordan, Dana Village 25.V.99	1♀
<i>Citrostichus phyllocnistoi- des</i> (Narayanan)	Lepidoptera: Nepticu- lidae	<i>Pistacia lentiscus</i> L.	Zucco 4.IV.00	1♂, 1♀
	<i>Stigmella</i> sp. (Lepidop- tera: Nepticulidae)	<i>R. ulmifolius</i>	Jordan, Al Bahhath (Amman) 23.V.99	1♂, 1♀
<i>Cirrospilus ingenuus</i> Gahan	Diptera: Agromyzidae	<i>Salix</i> sp.	Al Bahhath 23.V.99	1♀
<i>Cirrospilus variegatus</i> (Masi)	<i>C. horticola</i>	<i>Reichardia picroides</i> (L.)	Italy, Collesano (Paler- mo) 20.V.99	1♀
	<i>Liriomyza congesta</i> (Becker) (Diptera: Agromyzidae)	<i>Lathyrus pratensis</i> L.	Collesano 20.V.99	1♀
	<i>Euleia heraclei</i> (L.) (Diptera: Tephriti- dae)	<i>Smyrniun perfoliatum</i> (L.)	Italy, Petralia Sottana (Palermo) 6.VI.99	3♀
	Lepidoptera: Nepticu- lidae	<i>P. lentiscus</i>	Zucco 27.VIII.99	1♂
	Lepidoptera: Nepticu- lidae	<i>Chirozophora tinctoria</i> (L.)	Jordan, Aqaba 27.V.99	3♂, 4♀
<i>Ratzeburgiola incompleta</i> Bouček	Diptera: Agromyzidae	<i>Salix</i> sp.	Al Bahhath 23.V.99	1♂
<i>Ratzeburgiola cristata</i> (Ratzeburg)	<i>L. congesta</i>	<i>L. pratensis</i>	Collesano 20.V.99	2♀
<i>Neochlysocharis formosa</i> (Westwood)	<i>D. scalariella</i>	<i>Borago officinalis</i> L.	Italy, Bagheria (Paler- mo) 20.XI.97	1♀
	<i>Leucoptera malifoliella</i> (Costa) (Lepidop- tera: Gracillariidae)	<i>Crataegus monogyna</i> Jacq.	Zucco 7.VIII.99	7♀
	<i>Liriomyza bryoniae</i> (Kaltenbach)	<i>Matthiola incana</i> (L.)	Al Bahhath 23.V.99	1♂, 2♀
	Lepidoptera: Nepticu- lidae	<i>C. tinctoria</i>	Aqaba 27.V.99	2♂, 1♀
<i>Ascodes delucchii</i> (Bouček)	Diptera: Agromyzidae	<i>Salix</i> sp.	Al Bahhath 23.V.99	1♀

sin (Bouček 1969, 1970, Schauff *et al.* 1998), this species is known to parasitize *Holocacista rivillei* Stainton (Lepidoptera: Heliozelidae) (Bouček, 1969), *Phyllonorycter corylifoliella* Hübner (Lepidoptera: Gracillariidae) (Mineo and Sinacori 1998), *Cosmopterix pulchrimella* Chambers (Lepidoptera: Cosmopterigidae) (Rizzo and Mineo 1997), *Liriomyza trifolii* (Burgess) (Diptera: Agromyzidae) (Freidberg and Gijswijt 1983), *Liriomyza* sp. (Diptera: Agromyzidae) (Rizzo and Mineo 1997), and *Agromyza hiemalis* (Massa and Rizzo 2000). It is also recorded as CLM parasitoid (Azawi 1997, Schauff *et al.* 1998), and as the most abundant native CLM parasitoid in Turkey (Uygun *et al.* 1997) and Israel (Rössler and Argov 1997).

*Ratzeburgiola cristata* (Ratzeburg)

Known from the whole Europe (Bouček and Askew 1968, Rizzo and Mineo 1997, Schauff *et al.* 1998) parasitizing *Phyllonorycter nigrescentella* Logan (Lepidoptera: Gracillariidae) and *Cosmia trapezina* L. (Lepidoptera: Noctuidae) (Bouček and Askew 1968), *Chrysoesthia sexguttella* (Thunberg) (Lepidoptera: Gelechiidae), *Cosmopterix pulchrimella* and *Stigmella aurella* (Rizzo and Mineo 1997), and the CLM in Spain (Schauff *et al.* 1998). Agromyzidae previously has not been recorded as a host for this parasitoid.

*Neochrysocharis formosa* (Westwood)

This species is known from the Palearctic, Asia and Africa (Bouček and Askew 1968). It develops as a primary endoparasitoid of larvae, and rarely eggs, of leaf-miners (Hansson 1990), and is known as parasitoid of *P. citrella* in Cyprus, Greece, Israel, Italy, Japan, Jordan, Spain, Tunisia and Turkey (Caleca *et al.* 1996, FAO 1996, Ujiye *et al.* 1996, Schauff *et al.* 1998).

*Asecodes delucchii* (Bouček)

*Asecodes delucchii* (= *Teleopteris delucchii*) is known throughout the Palearctic Region from England to Japan (J. LaSalle,

pers. comm.), but has not been previously recorded in Jordan. It is known to attack *P. citrella* in Italy and Japan (Ujiye and Adachi 1995, Ujiye *et al.* 1996, Mineo 1999), and has also been recorded as a parasitoid of *Caliroa cerasi* L. (Hymenoptera: Tenthredinidae) and *Phyllonorycter messaniella* (Zeller) (Lepidoptera: Gracillariidae) (J. LaSalle, pers. comm.). Agromyzidae previously has not been recorded as a host for this parasitoid.

## DISCUSSION

The introduction of exotic polyphagous parasitoids could decrease native parasitoids competing for the same food resource (Bennett 1993, Duan *et al.* 1996); thus, due to the naturally low density of their populations, native polyphagous parasitoids may undergo dramatic decrease to become locally extinct (LaSalle 1993). For these reasons, to find the best control agent of a noxious insect before using it in biological control programs LaSalle (1993) suggested carrying out research on the biology and ecology of species of parasitoids that are considered antagonists of the host.

Since 1993, when *P. citrella* colonised Mediterranean citrus groves, endemic biological diversity represented the potential resource for biological control (cf. LaSalle 1993). A dozen native polyphagous eulophids were found to parasitize it. These species constituted the parasitoid community living on leaf-miners of the native flora. Research carried out in Sicily listed a total of 47 associations involving native eulophids that parasitize the CLM (Caleca *et al.* 1997, Mineo *et al.* 1997a, 1997b, Caleca 1998, Caleca *et al.* 1998, Mineo and Sinacori 1998, Rizzo *et al.* 1999, Massa and Rizzo 2000, present study) (cf. Fig. 1a). Among CLM parasitoids, the genus *Cirrospilus* (Hymenoptera: Eulophidae) played a dominant role, particularly *C. pictus* (Nees) in Sicily, Algeria and Spain (Caleca *et al.* 1998, Guenaoui and Dahlis 1997, Vercher *et al.* 1997). Due to

the spread of CLM, many researchers planned the introduction of its specific control agents; in the Mediterranean Basin today at least 6 exotic species, known as dominant parasitoids of *P. citrella*, have been introduced (Argov and Rössler 1996). Among them *S. petiolatus* spontaneously colonised Sicily (Mineo *et al.* 1998), probably from N Africa, where it had been introduced, while *Ageniaspis citricola* Logvinovskaya (Hymenoptera: Encyrtidae) and the eulophids *Quadrastichus* sp. and *C. phyllocnistoides* were here actively introduced (Siscaro *et al.* 1997, Mineo and Mineo 1999b).

Our research led us to find 5 alternative new native hosts of *S. petiolatus* and 2 of *C. phyllocnistoides*, as well as another new host of *C. ingenuus*, eulophids previously known as dominant or specialist CLM parasitoids. We believe that alternative hosts, leaf-miners of native flora, contributed to acclimatation of *S. petiolatus* and *C. phyllocnistoides* in Sicily, providing alternative food and shelter, mainly in winter and spring, when CLM populations decrease very much (Massa and Rizzo in press). As regards the interference determined on native CLM parasitoids by exotic ones, *S. petiolatus* in 1998 represented as much as 38% of all the parasitoids in an orange grove, with an average parasitization rate of 6.9%, peaking to 87.5% in September (Caleca *et al.* 1998), while in 1999 it represented 89% of all the parasitoids in a lemon grove, with a peak of parasitization rate of 69.6% (Mineo and Mineo 1999b), playing a dominant role in the CLM control. *C. phyllocnistoides* on the contrary seems to be still sporadic in Sicily (Mineo and Mineo 1999b).

Among native CLM parasitoids in Sicily, in 1998 *C. pictus* reached 7.9% of parasitization rate, while all the other parasitoids did not exceed 2% (Caleca *et al.* 1998), values already known before the introduction of exotic parasitoids. As regards the parasitization on hosts of native flora, even if our data do not present a

significant quantitative analysis, from the qualitative point of view it seems that the community structure of parasitoids did not change after the introduction of exotic species (Caleca *et al.* 1997, Mineo *et al.* 1997a, 1997b, Caleca 1998, Caleca *et al.* 1998, Mineo and Sinacori 1998, Rizzo *et al.* 1999, Massa and Rizzo 2000). The number of individuals of *S. petiolatus* and *C. phyllocnistoides* found parasitizing native hosts indeed is still low, compared with the whole number of parasitoids (564) obtained during our research (Massa and Rizzo in press).

Finally, our results point out that native flora within and at the edge of citrus groves strengthens the biological control of *P. citrella*, providing alternative hosts to its parasitoids, native as well exotic, mainly in the winter-spring seasons when *P. citrella* density is very low. Additionally, they stress the importance of knowledge of parasitoid biology and ecology to optimise their use in biological control programs, as well the conservation of native parasitoid communities.

#### ACKNOWLEDGMENTS

The authors thank Prof. Pietro Mazzola and Dr. Lorenzo Gianguzzi (Dipartimento di Scienze Botaniche, Palermo) for plant identification; Prof. Luciano Süs (Istituto di Entomologia agraria, Milan), Dr. Paolo Triberti (Museo di Storia Naturale, Verona), Dr. Erik Van Nieukerken (Rijksmuseum van Natuurlijke Historie, Leiden) and Dr. John LaSalle (CABI Bioscience UK Centre, Biology Dept., Ascot) for the identification of Agromyzidae, Gracillariidae, Nepticulidae and some Eulophidae, respectively; Prof. Ahmad Katbeh-Bader (Horticulture and Plant Protection Dept., Jordan Univ., Amman), Dr. Salvatore Blando, Rocco Lo Duca, Dr. Gabriella Lo Verde and Dr. Valentina Lo Verde (Istituto di Entomologia agraria, Palermo Univ.) for their help in the field; and Prof. Attilio Carapezza (Palermo University) for improving English. Paper funded by C.N.R. and M.U.R.S.T.

#### LITERATURE CITED

- Altieri, M. A. 1987. *Agroecology*. Intermediate Technology Publications, London. 227 pp.
- Argov, Y. and Y. Rössler. 1996. Introduction, release and recovery of several exotic natural enemies for biological control of the citrus leafminer *Phyl-*

- locnistic citrella* Stainton in Israel. *Phytoparasitica* 24: 33–38.
- Azawi, A. A. 1997. Some notes on the Citrus Leaf-miner, *Phyllocnistis citrella* Stainton (Lepidoptera Gracillariidae) in middle Iraq. In: *Sixth Arab Congress of Plant protection. Abstract book*, Beirut. 82 pp.
- Bennett, F. D. 1993. Do introduced parasitoids displace native ones? *Florida Entomologist*, 76: 54–63.
- Bouček, Z. 1969. Descriptive and taxonomic notes on ten, mainly new, species of West Palearctic Eulophidae (Hymenoptera). *Acta entomologica Musei Nationalis Pragae* 38: 525–543.
- Bouček, Z. 1970. Contribution to the knowledge of Italian Chalcidoidea, based mainly on a study at the Institute of Entomology in Turin, with descriptions of some new European species (Hymenoptera). *Memorie Società entomologica Italiana* 49: 35–102.
- Bouček, Z. 1988. *Australasian Chalcidoidea (Hymenoptera). A biosystematic revision of genera of fourteen families, with a reclassification of species*. CAB International, Wallingford, Oxon. 832 pp.
- Bouček, Z. and R. R. Askew. 1968. Index of Palearctic Eulophidae (excl. Tetrastichinae) In, *Index of Entomophagous Insects* (Delucchi, V. and Remaudière, G. eds.) Le François, Paris. 254 pp.
- Caleca, V. 1998. Parassitoidi riscontrati in Sicilia su fillominatori della flora ripariale limitrofa ad agrumeti e su *Phyllocnistis citrella* Stainton (Lepidoptera: Gracillariidae). *Phytophaga* 7: 45–56.
- Caleca, V. and G. Lo Verde. 1998. Sul controllo naturale di *Phyllocnistis citrella* Stainton (Lepidoptera: Gracillariidae) esercitato da parassitoidi. *Phytophaga* 7: 65–75.
- Caleca, V., G. Lo Verde, and B. Massa. 1996. Indagine su *Phyllocnistis citrella* Stainton (Lepidoptera Gracillariidae) in un limoneto della Sicilia occidentale. *Bollettino Zoologia agraria e Bachicoltura Ser. II* 28: 165–183.
- Caleca, V., M. C. Rizzo, and B. Massa. 1997. Parassitoidi dei fillominatori della flora spontanea degli agrumeti della Sicilia. *Il Naturalista siciliano* 21: 33–38.
- Caleca, V., G. Lo Verde, S. Blando, and V. Lo Verde. 1998. New data on the parasitism of citrus leaf-miner (*Phyllocnistis citrella* Stainton, Lep. Gracillariidae) in Sicily. *Bollettino Zoologia agraria e Bachicoltura Ser. II* 30: 213–222.
- Dash, P. C. and A. K. Das. 1997. Arthropod fauna associated with kendu, *Diospyros melanoxylon* (Roxb.) (Ebenaceae) in Orissa. *Insect Environment* 3: 71–72.
- Duan, J. J., M. F. Purcell, and R. H. Messing. 1996. Parasitoids of non-target tephritid flies in Hawaii: implications for biological control of fruit fly pests. *Entomophaga*, 41: 245–256.
- FAO. 1996. *Report of the workshop on Citrus Leafminer (Phyllocnistis citrella) and its Control in the Near East, Safita (Tartous), Siria, 30 Sep.–3 Oct. 1996*. Food and Agricultural Organization of the United Nations, Regional Office for the Near East, Cairo.
- Freidberg, A. and M. J. Gijswijt. 1983. A list and preliminary observations on natural enemies of the leafminer *Liriomyza trifolii* (Burgess) (Diptera Agromyzidae) in Israel. *Israel Journal of Entomology* 18: 115–116.
- Guenaoui, Y. and A. Dahliz. 1997. A new serious pest in Algeria: *Phyllocnistis citrella* Stainton (Lepidoptera: Gracillariidae). *Bulletin de l'Organisation Internationale Lutte Biologique et Intégrée—Section Régionale Ouest Paléarctique (OILSB/SROP)* 20 (7): 63–70.
- Hamed, A. R., P. M. Reckhaus, F. N. Mahrous, N. Z. Soliman, and W. Gassert. 1999. A successful biological control program for the citrus leafminer *Phyllocnistis citrella* Stainton (Lepidoptera: Gracillariidae) in Egypt. In: *Proceedings of the 1st Regional Symposium on Applied Biological Control in Mediterranean Countries* (Canard M. and Beysat—Arnaouty V., eds.), pp. 139–142. Cairo, Egypt.
- Hansson, C. 1990. A taxonomic study on the Palearctic species of *Chrysonotomyia* Foerster and *Neochrysocharis* Kurdjumov (Hymenoptera: Eulophidae). *Entomologica Scandinavica* 20: 29–52.
- LaSalle, J. 1993. Parasitic Hymenoptera, Biological Control and Biodiversity. In: *Hymenoptera and Biodiversity* (LaSalle, J. and Gauld, I. D. eds.), pp. 197–215. CAB International, Wallingford, UK.
- LaSalle, J., R. E. Duncan, and J. E. Pena. 1999. The recovery and apparent establishment of *Cirrospilus ingenuus* (Hymenoptera: Eulophidae) in Florida. *Florida Entomologist* 82: 371–373.
- Masi, L. 1907. Contribuzioni alla conoscenza dei calcididi italiani. *Bollettino Laboratorio di Zoologia generale e agraria di Portici* 1: 231–295.
- Massa, B. and M. C. Rizzo. 2000. *Agromyza hiemalis* Becker (Diptera, Agromyzidae) leaf-miner of nettle (*Urtica* spp.): phenology and parasitoids in Italy. *Phytophaga* 10: 53–67.
- Massa, B. and M. C. Rizzo. In press. Comunità di parassitoidi di fitofagi della flora spontanea antagonisti di *Phyllocnistis citrella* Stainton (Lepidoptera, Gracillariidae). *Atti dell'Accademia Nazionale Italiana di Entomologia*.
- McMurtry, J. A. and H. G. Johnson. 1965. Some factors influencing the abundance of the predaceous mite *Amblyseius hibisci* in Southern California

- (Acarina: Phytoseiidae). *Annals of the entomological Society of America* 58: 49–56.
- Michelakis, S. E. 1997. The citrus leafminer status in Greece. *Bulletin de l'Organisation Internationale Lutte Biologique et Intégrée—Section Régionale Ouest Paléarctique (OILSB/SROP)* 20 (7): 81–82.
- Mineo, G. 1999. Records on indigenous antagonists of *Phyllocnistis citrella* Stainton (Lepidoptera Gracillariidae) new for Italy. *Bollettino Zoologia agraria e Bachicoltura* 31: 97–105.
- Mineo, G. and N. Mineo. 1999a. Ulteriori dati sull'acclimatazione di *Semiela cher petiolatus* (Girault) (Hym. Eulophidae) in Sicilia. *Bollettino Zoologia agraria e Bachicoltura* 31: 235–239.
- Mineo, G. and N. Mineo. 1999b. Introduzione di *Citrosticticus phyllocnistoides* (Narayanan) in Sicilia e suo allevamento simultaneo con *Semiela cher petiolatus* (Girault) (Hym. Eulophidae). *Bollettino Zoologia agraria e Bachicoltura* 31: 197–206.
- Mineo, G. and A. Sinacori. 1998. Interrelazioni tra l'artropodofauna dell'agrumeto e quella della flora associata. *Bollettino Zoologia agraria e Bachicoltura* Ser. II 30: 313–319.
- Mineo, G., A. Sinacori, and B. Massa. 1997a. L'artropodofauna associata a *Parietaria* spp. (Urticaceae). 1a nota. *Il Naturalista siciliano* 21: 25–32.
- Mineo, G., A. Sinacori, M. C. Rizzo, and B. Massa. 1997b. L'artropodofauna associata a *Parietaria* spp. (Urticaceae). 3a nota. Parassitoidi di *Cosmopterix pulchrimella* Chambers (Lepidoptera: Cosmopterigidae). *Bollettino Zoologia agraria e Bachicoltura* Ser. II 29: 195–198.
- Mineo, G., V. Caleca, and B. Massa. 1998. *Semiela cher petiolatus* (Girault) (Hymenoptera Eulophidae), natural antagonist of *Phyllocnistis citrella* Stainton (Lepidoptera Gracillariidae), new for Italian entomofauna. *Il Naturalista siciliano* 22: 3–6.
- Nia, M., M. Abbassi, A. Rizki, M. Zenzami, and E. B. Nadori. 1997. Introduction d'auxiliaires et perspectives de lutte biologique au Maroc contre la mineuse des feuilles de Citrus, *Phyllocnistis citrella* Stainton. In: *International Conference on pests in Agriculture*, A.N.P.P. 3: 731–734. Montpellier, France.
- Perales-Gutierrez, M. A., H. C. Arredondo Nernal, E. Garza-Gonzalez, and L. A. Aguirre-Urbe 1996. Native parasitoids of citrus leafminer *Phyllocnistis citrella* Stainton in Colima, Mexico. *Southwestern Entomologist* 21: 349–350.
- Peter, C. and R. Balasubramanian. 1984. New report of parasites on mango feaweevil, *Rhynchacnus mangiferae* (Coleoptera: Curculionidae). *Entomon* 9: 73.
- Powell, W. 1986. Enhancing Parasitoid Activity in Crops. In: *Insect Parasitoids* (Waage J. and Greathead D., eds.). Academic Press, London, UK. 389 pp.
- Ragusa Di Chiara, S. 1991. Using native Phytoseiids in agricultural cropping systems. In: *Modern Acarology* (Dusbabek F. and Burkva V., eds.), 1: 159–166. Academia, Prague, SPB Acad. Publ., The Hague.
- Raimondo, F. M., D. Ottonello, and G. Castiglia. 1979. Aspetti stagionali e caratteri bio-corologici della vegetazione infestante gli agrumeti del palermitano. *Notulae Fitosociologicae* 15: 159–170.
- Rizzo, M. C. and G. Mineo. 1997. Interrelazioni tra l'artropodofauna dell'agrumeto e quella della sua flora sinantropica: ospiti delle specie di *Ratzeburgiola* Erdős 1958 (Hymenoptera Eulophidae) presenti in Sicilia. *Phytophaga* 7: 57–64.
- Rizzo, M. C., B. Massa, and G. Mineo. 1999. Interrelations between entomofauna of the synanthropic vegetation and that one of the citrus groves. In: *Proceedings of the 1st Regional Symposium on Applied Biological Control in Mediterranean Countries* (Canard M. and Beyssat—Arnaouty V., eds.), pp. 193–202. Cairo, Egypt.
- Rössler, Y. and Y. Argov. 1997. Introduction and release of exotic natural enemies to control the citrus leafminer (*Phyllocnistis citrella* Stainton) in Israel: interim report 1994–96. *Bulletin de l'Organisation Internationale Lutte Biologique et Intégrée—Section Régionale Ouest Paléarctique (OILSB/SROP)* 20 (7): 91–95.
- Schauff, M. E., J. LaSalle, and G. A. Wijesekara. 1998. The genera of chalcid parasitoids (Hymenoptera: Chalcidoidea) of citrus leafminer *Phyllocnistis citrella* Stainton (Lepidoptera: Gracillariidae). *Journal of Natural History* 32 (7): 1001–1056.
- Siscaro, G., S. Barbagallo, S. Longo, and I. Patti. 1997. Prime acquisizioni sul controllo biologico ed integrato della minatrice serpentina degli agrumi in Italia. *Informatore Fitopatologico* 7/8: 19–26.
- Smith, D., G. A. C. Beattie, and R. Broadley (Eds.). 1997. *Citrus pests and their natural enemies. Integrated pest management in Australia*. DPI, Queensland, Australia. 272 pp.
- Ujiye, T. and I. Adachi. 1995. Parasitoids of the citrus leafminer, *Phyllocnistis citrella* Stainton (Lepidoptera: Phyllocnistidae) in Japan and Taiwan. *Bulletin of Fruit Tree Research Station* 27: 79–102.
- Ujiye, T., K. Kamijo, and R. Morakote. 1996. Species composition of parasitoids and rate of parasitism of the citrus leafminer (CLM) *Phyllocnistis citrella* Stainton (Lepidoptera: Gracillariidae) in central and northern Thailand, with key to parasitoids of CLM collected from Japan, Taiwan and Thailand. *Bulletin of Fruit Tree Research Station* 29: 79–106.

- Uygun, N., N. Z. Elekçioğlu, L. Erkiliç, I. Karaca, and U. Kersting. 1997. Studies on biological control of *Phyllocnistis citrella* Stainton (Lep., Gracillariidae) in Turkey. *Bulletin de l'Organisation Internationale Lutte Biologique et Intégrée—Section Régionale Ouest Paléarctique (OILSB/SROP)* 20: 96–101.
- Vercher, R., M. J. Verdu, J. Costa-Comelles, and F. Garcia-Mari. 1997. Autoctonous parasitoids of the citrus leaf miner *Phyllocnistis citrella* in Valencia (Spain). *Bulletin de l'Organisation Internationale Lutte Biologique et Intégrée—Section Régionale Ouest Paléarctique (OILSB/SROP)* 20: 102–106.
- Wu, T. K. and K. S. Lin. 1998. Influence of green lacewing, *Mallada basalis* (Walker) (Neuroptera: Chrysopidae), on parasitoids of citrus leafminer *Phyllocnistis citrella* Stainton (Lepidoptera: Phyllocnistidae). *Chinese Journal of Entomology* 18: 13–25.
- Yefremova, Z. A. 1996. Notes on some Palearctic and Afrotropical species of the genus *Zagrammosoma* (Hymenoptera, Eulophidae). *Entomological Review* 75 (5): 163–171.

## Interactions Between Adults of Some Species of *Netelia* Gray (Hymenoptera: Ichneumonidae: Tryphoninae) and Their Caterpillar Hosts (Lepidoptera)

MARK R. SHAW

National Museums of Scotland, Chambers Street, Edinburgh, EH1 1JF, UK

---

*Abstract.*—Five species from three subgenera of *Netelia* were observed ovipositing on their hosts under laboratory conditions. Two species of the subgenus *Bessobates* oviposited without a separate insertion of the ovipositor beforehand. One species of the subgenus *Netelia* and two of the subgenus *Paropheltes* employed a venom causing weak (often incomplete) temporary paralysis, administered as a separate action prior to oviposition. The venoms had no long-term adverse effect on hosts and it appears that these taxa, and perhaps all other groups of ectoparasitic koinobiont Ichneumonidae, lack the host-regulating venom systems that have been regarded as instrumental in the evolution of endoparasitism in some koinobiont cyclostome Braconidae. In all species substantial parasitoid development was delayed until the final instar host had constructed its pupation site, wherein it was overwhelmed as a prepupa. Species of all three subgenera dumped eggs in the absence of hosts, and (if kept humid) such eggs subsequently split to reveal a living first instar larva (but not investigated in the subgenus *Paropheltes*). Species of all three subgenera indulged in non-destructive concurrent host-feeding, despite being supplied with honey solution *ad libitum*, making the necessary wounds on the host's body with their mandibles. Occasionally non-destructive host-feeding occurred on hosts that were not also being parasitised.

---

The main purpose of this study was to investigate the effect of the venom of species of *Netelia* Gray (= *Paniscus* auctt. nec Schrank) (Ichneumonidae: Tryphoninae) on their caterpillar hosts, but in the course of conducting experiments observations were also made on host-feeding, oviposition behaviour, egg dumping, egg hatching and (in one species) copulation.

Many koinobiont parasitic wasps—that is, those in which the host continues to develop after being parasitised—influence the subsequent physiology, behaviour and development of their hosts in various and often profound ways (Vinson and Iwantsch 1980, Beckage 1985, 1991, Lawrence 1986, Barnard and Behnke 1990; see also Quicke 1997). In some, injections of materials (“venoms” in the broadest sense) other than eggs by the female parasitoid during the oviposition sequence are known to be at least partly responsible

(Shaw 1981, Tanaka 1987, Jones 1987, Dover *et al.* 1988, Leluk and Jones 1989). In endoparasitoids the effect on the host of venoms independent of parasitisation as such is usually difficult to investigate directly because the egg is injected concurrently; that is, during a single insertion of the ovipositor. In some koinobiont cyclostome Braconidae, however, venoms initially causing paralysis that is only temporary are injected as a preliminary and separate action prior to oviposition, and in some taxa the venom has been shown to switch the host, which initially recovers to resume feeding, to a prepupal stage in which it is arrested (Shaw 1981, 1983). This includes cocoon formation and the secretion of pupal cuticle, both of which happen precociously (i.e. an instar early) if the host is attacked in its nominally penultimate larval instar, and two koinobiont cyclostome braconid genera, the ectopar-

asitic *Rhysipolis* Foerster (Rhysipolinae) and the endoparasitic *Clinocentrus* Haliday (Rogadinae), were found to employ venoms having identical effects on their hosts. Although these taxa are not regarded as extremely closely related, the suggestion (Shaw 1983) that on at least one occasion the evolution of endoparasitism from ectoparasitoid ancestry within the Exothecinae-Rhysipolinae-Rogadinae group of subfamilies was enabled as a result of these controlling venom systems, which arose originally as adaptations to the host's feeding and pupation biology, has been supported by other evidence (Whitfield 1992).

Gauld (1988) envisaged that within the Ichneumonidae idiobiont endoparasitism arose from idiobiont ectoparasitic ancestry, and koinobiont endoparasitism from koinobiont ectoparasitic ancestry. The mechanisms for such transitions remain uncertain but it is possible in principle that the latter route may have involved venom systems similar to those seen in some cyclostome Braconidae. However, evidence for such venom effects in Ichneumonidae has not been directly sought, although it is known that in some endoparasitoid subfamilies (particularly Campopleginae) complex physiological processes ensue from substances injected simultaneously with eggs. Three extant groups of koinobiont ectoparasitoid Ichneumonidae are known: Adelognathinae (most investigated species, parasitoids of sawfly larvae); the *Polysphincta* Gravenhorst genus-group (= Polysphinctini sensu Townes 1969, but see Wahl and Gauld 1998) of the Pimplinae (parasitising spiders); and Tryphoninae (parasitising sawfly and Lepidoptera larvae). At least some members of each group are known to inject venoms causing temporary paralysis as separate actions prior to oviposition (as in *Rhysipolis* and the endoparasitic *Clinocentrus*), offering particularly convenient opportunities to interrupt the oviposition sequence so as to observe any venom effects

in isolation. Indications exist (see Discussion) that in Adelognathinae and the *Polysphincta* genus-group these venom systems are innocuous, in the sense of causing only temporary paralysis rather than exerting lasting control over the host's development, but for the third group, Tryphoninae, essential information is lacking. Because Tryphoninae generally kill the host as a prepupa, the possibility that they employ venoms that disrupt processes normally under endocrine control (as with *Rhysipolis* and *Clinocentrus*) seemed particularly worth examining.

Tryphonines are predominantly (at least at the generic level) parasitic on Symphyta but the family contains the tribe Phytodietini, including the genera *Netelia* and *Phytodietus* Gravenhorst, which attack Lepidoptera larvae. In view of the ease of culturing their hosts, species of *Netelia* were chosen for study. *Netelia* species anchor their highly characteristic stalked black, and typically glossy, eggs externally on the thoracic segments of active exposed Lepidoptera larvae that are normally consumed only after constructing their pupation chambers (i.e. as prepupae). The genus contains species for which temporary paralysis of the host has been reported as well as others that apparently oviposit without having this effect (e.g. Stenton 1910, Shevyrev 1912, Vance 1927). While many observations have been published on the egg structure and larval development of *Netelia* (e.g. Stenton 1910, Cushman 1913, Strickland 1923, Vance 1927, Guppy 1961, Danks *et al.* 1979, Ellis 1998), the possibility that venoms may have arresting effects beyond that of causing temporary paralysis appears never to have been considered.

Yu and Horstmann (1997) recognise eleven subgenera of *Netelia* of which four, *Netelia* s. str., *Paropheltes* Cameron, *Bessobates* Townes, Townes and Gupta, and *Parabates* Foerster, are known to occur in Britain. This paper records the outcome of experiments to investigate possible long-

term venom effects in the first three of these subgenera of *Netelia*, and notes also other aspects of parasitoid behaviour and host development.

The following species were used in experiments (comment on phenology and host range is supported by reared material in the National Museums of Scotland (NMS)): *Netelia (Bessobates) cristata* (Thomson), a plurivoltine and normally solitary parasitoid of various exposed Noctuidae; *N. (B.) latungula* (Thomson), a univoltine, solitary and regular parasitoid of *Operophtera brumata* (Linnaeus), sometimes reared also from other spring-feeding arboreal Geometridae; *N. (Netelia) vinulae* (Scopoli) (= *cephalotes* (Holmgren)), a univoltine, gregarious and regular parasitoid of *Cerura vinula* (Linnaeus) (Notodontidae); *N. (Paropheltes) tarsata* (Brischke), a plurivoltine solitary parasitoid of small Geometridae, especially species of *Eupithecia* Curtis; and *N. (P.) ?thomsoni* (Brauns), in Britain a widespread plurivoltine parasitoid of *Xanthorhoe fluctuata* (Linnaeus) and other similarly small to medium sized Geometridae. The latter comes closer to *N. (P.) inedita* (Kokujev) than to *thomsoni* in Delrio (1975), but Yu and Horstmann (1998) give the latter as a senior synonym. Delrio (1975) records *thomsoni* from Geometridae including *Eupithecia* species.

#### METHODS

All livestock originated from England. Adult parasitoids were identified by reference to Delrio (1975), and voucher specimens are deposited in the NMS.

*Netelia (Bessobates) cristata*. One female (unmated) reared from *Cosmia trapezina* (Linnaeus) from Hartslock, Oxfordshire, was used in experiments. The experimental host, *Lacanobia oleracea* (Linnaeus), was reared from the previous generation in culture and fed on leaves of *Taraxacum* Weber and *Crataegus* Linnaeus.

*Netelia (Bessobates) latungula*. Adults used in experiments were collected by sweeping *Corylus* Linnaeus at Hell Cop-

pice, Buckinghamshire (two females), and reared from *O. brumata* from Gait Barrows NNR, Lancashire (one female, unmated). Experimental hosts were wild-collected larvae of *O. brumata* (*Corylus*, Hell Cop-pice; *Corylus*, Pamber Forest, Hampshire; and *Salix* Linnaeus, Otmoor, Oxfordshire), and cultured *O. brumata* and *Theria primaria* (Haworth) from the previous generation. All hosts were fed on leaves of *Crataegus*. Some *O. brumata* larvae bearing eggs of *N. latungula* when collected were also investigated.

*Netelia (Netelia) vinulae*. Parasitised larvae of *C. vinula*, collected at Druridge Bay, Northumbria, were received from H. A. Ellis (cf. Ellis 1998) and provided the adult *N. vinulae* used the following year. Five females (at least two mated and at least two virgin) were involved in experiments. Larvae of the experimental host, *C. vinula*, were obtained from livestock dealers (ex culture) and fed on leaves of *Salix*.

*Netelia (Paropheltes) tarsata*. One female (unmated) reared from *Eupithecia absinthiata* (Clerck) from Sheffield, Yorkshire (received from T. H. Ford) was used in experiments. The experimental host, *Eupithecia vulgata* (Haworth), was cultured from the previous generation and fed on leaves of *Crataegus*.

*Netelia (Paropheltes) ?thomsoni*. One female (unmated) reared from *Xanthorhoe fluctuata* from Hampstead Heath, London (received from R. A. Softly) was used in experiments. *Eupithecia nanata* (Hübner), cultured from the previous generation and fed on *Calluna* Salisbury, and *Eupithecia* sp. collected wild from *Quercus* Linnaeus at Pamber Forest, Hampshire were experimental hosts.

All female parasitoids were seen to feed on honey: water (ca 1:3), with which they were kept at all times in corked glass tubes or clear plastic boxes (see below) apart from the brief periods of experimental manipulation. Lepidoptera larvae were fed in ca 16 × 8 × 6cm closed clear plastic boxes lined with copious absorbent tissue

paper. All livestock was kept in an unheated, detached and fully shaded outdoor shed under conditions of natural temperature and daylength except during experiments under observation.

Experimental exposures of hosts to parasitoids were done under observation (except for some with *N. (B.) cristata*—see Results) in  $2.5 \times 7.5$  cm corked glass tubes (*N. (B.) latungula* and the two *N. (Paropheltes)* species), or in ca  $16 \times 8 \times 6$  cm clear plastic boxes (*N. (B.) cristata* and *N. (N.) vinulae*).

## RESULTS

*Netelia (Bessobates) cristata*.—Eggs were mature by the twelfth day after adult emergence. Egg dumping was not seen, probably because the single parasitoid observed was never deprived of hosts for long. This species is almost completely nocturnal and only four parasitisations (one with successful non-destructive concurrent host-feeding—see Jervis and Kidd 1986 for explanation of these terms) and one further non-destructive but non-concurrent host-feeding event were observed directly. For oviposition the female grasped the late final instar host with all six legs, oriented head to tail, and moved backwards along the host's body towards its head, then rapidly oviposited on a thoracic segment without separately stinging the host. In three cases the female then tried to bite the host mid-dorsally, presumably in order to host-feed, but in each case the host writhed furiously and she was thrown off. In the only other oviposition sequence observed the parasitoid laid a second egg, without releasing the host, before successfully host-feeding on haemolymph via a wound made with the mandibles. Host-feeding without oviposition was observed on one host (earlier in its final instar)—as in oviposition sequences the host was grasped tightly with all six legs, and the female chewed a wound at which she fed midway along the host's dorsum, at the same time curling the tip

of her abdomen towards the host's thoracic segments but without ovipositing.

Otherwise parasitised hosts were obtained by keeping the single female overnight with 5–7 hosts in a cardboard shoe box (ca  $23 \times 13 \times 10$  cm) closed with a sheet of glass, and removing the contents the following morning. Penultimate instar hosts, and those early in their final instars, never received eggs, but over a thirteen day period the female laid 54 eggs (50 of them in the last nine days) on late final instar larvae until the experiment was curtailed for want of further host larvae, although the female parasitoid lived for about another 55 days (ca 80 as an adult in all). At the end of a night, sixteen hosts had received one egg; nine had received two; two had received four; and one had received twelve eggs (generally, some hosts had also received no eggs, but as the smaller hosts were clearly less attractive there is no scope to analyse egg distribution). The host with twelve eggs was reared and five parasitoid cocoons resulted; the two hosts with four eggs similarly each resulted in two cocoons; two of four hosts reared with two eggs yielded two cocoons and the other two a single cocoon each; and all seven hosts reared with single eggs duly yielded the single parasitoid cocoon expected. This suggests that competition causes some mortality but that broods of two will regularly be fully viable.

Nine hosts from which eggs were manually removed, and also one host bearing an egg that failed to hatch, produced pupae and then adult moths, apparently normally. Two eggs on one host were allowed to hatch (which occurred two and five days after oviposition) and on the sixth day after oviposition the two larvae (four and one days old) were destroyed, after which the host pupated and became an adult moth. Two other hosts each bearing one parasitoid were reared for eight days after oviposition, by which time parasitoid larvae were ca six days old and ca three

times as long as the egg, before the parasitoid larvae were killed. Both hosts became prepupal within two days, but died without pupating, apparently in an arrested state.

In all wild and experimental rearings permitted to reach such a state, the host was consumed as a prepupa in its prepared pupation site, in which the parasitoid cocoon is constructed. The generation that overwinters does so in the cocoon.

*Netelia (Bessobates) latungula*.—Eggs were mature five days after adult emergence, and started to be dumped ca ten days after emergence in the absence of hosts. If kept humid dumped eggs later split to reveal a living first instar larva, just as did eggs laid on hosts. Penultimate instar hosts (both *O. brumata* and *T. primaria*) were rejected consistently, although sometimes investigated. Oviposition attacks on final instar hosts are evidently provoked by movement: hosts remaining still when contacted by the female were ignored. There was no pre-oviposition sting, the adult parasitoid rapidly pouncing on the host and ovipositing singly on one of the host's thoracic segments (very rarely at the host's caudal end: the two eggs laid in this position were quickly lost, possibly because the host could reach them with its mouthparts). After all seven ovipositions witnessed the host was then released, without the parasitoid attempting to host-feed. Some interactions, however, took a different course: in five cases the female parasitoid grasped a final instar *O. brumata* larva, jabbing it once with its ovipositor midway along its dorsum. Four of these larvae were then released and abandoned, but the parasitoid chewed a wound on the other from which it fed on haemolymph. No paralysis was evident.

Eggs were cut off eleven parasitised *O. brumata* larvae and two *T. primaria*, all of which pupated and produced adult moths. The five *O. brumata* which had been possibly stung but not oviposited

onto also pupated and produced adult moths apparently normally.

In a heavily parasitised field sample of final instar *O. brumata* larvae collected from *Corylus* on 7.vi.1979 at Hell Coppice, Buckinghamshire, 15 bore no eggs, 19 had one egg, and nine carried two eggs of *N. (B.) latungula*. Five of the latter nine produced single *N. (B.) latungula* cocoons (the other four produced other parasitoids preemptively), showing that this species is probably strictly solitary but apparently incapable of rejecting already parasitised hosts.

In all wild and experimental rearings permitted to reach such a state, the host was consumed as a prepupa in its prepared pupation site, and the parasitoid overwintered there in its own cocoon.

*Netelia (Netelia) vinulae*.—Two copulations each of about four minutes duration were observed: in both cases the male climbed on the dorsum of the female, which was standing on a horizontal surface, so that the copula was orientated head to head. This contrasts with the account of copulation given by Vance (1927) for *N. (N.) spinipes* (Cushman).

Female parasitoids contained mature eggs from about the eighth day after their emergence, and by the eleventh day females having had no access to hosts started to dump eggs on the sides of the container. Such eggs, if kept humid, later split to reveal the first instar larva, just as eggs placed on hosts. The females were offered both penultimate and final instar larvae, attacking the former (including those in proecdysis/apolysis between these instars) very much more readily. They advanced on hosts at first rather cautiously, making repeated stinging attacks with brief (rarely as long as a second) insertions of the ovipositor, usually in central positions along the host's body. The hosts, which at first attempted to defend themselves by thrashing and sometimes daubing oral secretions, were gradually subdued; those in the penultimate instar in

particular becoming markedly incapacitated, though not fully paralysed. The female then sometimes rejected hosts (in both penultimate and final instars) in which she had invested considerably (as many as ten stinging attacks) without ovipositing, or else she climbed onto the host and commenced oviposition onto thoracic segments. Each site for anchoring an egg appeared to be chosen with some deliberation. After the ovipositor tip was inserted through the host's cuticle it took approximately half a second for the egg to slide down the outside of the ovipositor to be anchored into the epidermis by its stalk, which travels down the ovipositor shaft internally. Host movement as it recovered during the egg-laying process greatly inhibited the female, and this may impose a strong limit to brood size (about 4–8 eggs seems usual). Following oviposition, the female usually fed on host haemolymph through a wound which it chewed with its mandibles mid-way along the host's dorsum. Hosts that were stung but then rejected were not fed on in this way, and haemolymph oozing from stinging sites was not imbibed. The behaviour of females towards hosts before their penultimate instar was not investigated. During host ecdysis eggs anchored into the epidermis of penultimate instar hosts easily tear through the cuticle being sloughed and losses are normally extremely low.

Three penultimate instar hosts that had suffered stinging attacks without oviposition, and three penultimate instar hosts on which oviposition had also occurred but the progeny was destroyed, were reared to investigate the effects of venom. All six pupated and produced adult moths contemporaneously with controls.

In all wild and experimental rearings permitted to reach such a state, the host was consumed as a prepupa in its prepared pupation site, and the parasitoids overwinter there in their own cocoons.

*Netelia (Paropheltes) tarsata*.—The female parasitoid lived as an adult from 5.vi until

24.ix, a period of 111 days. Hosts were not offered until the parasitoid's 60th day of adult life. An unknown number of eggs had been dumped but, once experiments commenced, further egg dumping was not seen, probably because the female was not then deprived of hosts. Indeed, on one occasion an egg that was clearly immature (greenish grey rather than the usual black in colour) was laid on a host, but this and also several others of the eggs laid failed to anchor adequately and were lost, presumably because the chorion had not sufficiently hardened. The eggs are more or less coriaceous and matt, unlike the shiny eggs seen in the species of the subgenera *Netelia* and *Bessobates* here studied. Final instar hosts were greatly preferred, though some ovipositions occurred on penultimate instar hosts (including one in the proecdysis/apolysis preceding the final instar). Hosts were stung once, with an insertion of the ovipositor into an abdominal position, causing partial temporary paralysis. The parasitoid then oviposited once onto a thoracic segment, and subsequently nearly always chewed a wound midway along the host's back from which it fed on haemolymph. In one case host-feeding commenced before oviposition and continued during it and for a time afterwards. Host-feeding was often so heavy (green fluid greatly distending the parasitoid's metasoma) that the female was unable to move with agility and did not attack further hosts until the following day. A limited capacity to deal with more than two hosts per day was also evidenced by her laying immature eggs (see above) and sometimes failing to produce enough venom to subdue hosts to the point that she was willing to oviposit on them.

Three penultimate instar and two final instar hosts that had received paralysing venom but no eggs, and three further final instar hosts that had also received eggs which were then removed, all pupated and produced adult moths apparently

normally. An additional four final instar and one penultimate instar hosts from which eggs had been removed died of a fungal disease that also affected some unexposed control larvae.

In all wild and experimental rearings permitted to reach such a state, the host was consumed as a prepupa in its prepared pupation site, and the generation that overwinters does so in the cocoon.

*Netelia (Paropheltes) ?thomsoni*.—Eggs (which are similar to those of *N. (P.) tarsata*) were dumped after several days of host deprivation. Two similar ovipositions were observed, on a final instar *Eupithecia nanata* and on a final instar *Eupithecia* sp. The female stung the host (10–20 seconds insertion) in an abdominal position causing rather full temporary paralysis; she then oviposited singly onto a thoracic segment, when the body of the egg was seen to slide down the outside of the ovipositor during ca 1 second; and subsequently she chewed a wound midway along the host's back from which she fed on haemolymph. The cultured host (*E. nanata*) died of a fungal disease and the other (wild collected) host proved to be already parasitised. No further trials could be conducted.

In all wild rearings the host was consumed as a prepupa in its prepared pupation site, and the generation that overwinters does so in the cocoon.

## DISCUSSION

Pre-oviposition venoms causing a degree of temporary paralysis have been reported in several species of the subgenus *Netelia* previously (Shevyrev 1912, Cushman 1926, Vance 1927) and studies on species of the subgenus *Bessobates* have either stated that no paralysis is caused (Shevyrev 1912) or been reported without mention of it (Stenton 1910, whose account of his parasitoid of *O. brumata* almost certainly refers not to *N. (B.) virgata* but to *N. (B.) latungula*, as it is clear from material in NMS that C. Morley, who had determined Stenton's specimens, regularly mis-

identified *latungula* as *virgatus*). The present study concurs with these earlier findings, but the biology of the subgenus *Paropheltes* does not seem to have been previously studied even to this extent.

The main finding of the present work is that no substances controlling host development are injected during the oviposition process in any of the three subgenera investigated, since hosts from which eggs had been removed developed normally. Thus the venoms injected prior to oviposition in the subgenera *Netelia* and *Paropheltes* have no effect on the host other than to subdue it, simply allowing the female parasitoid to place eggs accurately using its appreciably exerted ovipositor. Species of the subgenus *Bessobates*, which have markedly shorter ovipositors, oviposit more rapidly without immobilising the host other than physically by grasping it. Oviposition has been described for one species in the genus *Phytodietus*, the putative sister genus to *Netelia*, and a venom causing temporary paralysis, often requiring several insertions of the ovipositor as in *N. (N.) vinulae*, was observed (Simmonds, 1947). This may suggest that the use of a paralysing venom is plesiomorphic in *Netelia* (see also Kasparyan 1973 [1981:49]).

In all tribes of Tryphoninae other than Idiogrammatini and Phytodietini eggs ready for oviposition are commonly carried externally on the ovipositor until a host is found (pers. obs.; but for Ankylophonini and Sphinctini, A. Bennett pers. comm.). In the studied subgenera of *Netelia* (Phytodietini) this behaviour is not approached: in all three subgenera the egg did not start to issue from the parasitoid's genital opening until the ovipositor was inserted for attaching the egg to the host. Although observations of oviposition in the tribes carrying eggs on the ovipositor are rather sparse, only the exenterine *Exenterus abruptorius* (Thunberg) has been reported to cause temporary paralysis (Morris 1937). This observation would indicate

that carrying the egg on the ovipositor (which it is here presumed to be the case in *E. abruptorius*, though it is not explicitly stated to be so by Morris) does not preclude the use of a paralyzing venom, but the lack of records of paralysis by Exenterini and Tryphonini stemming from other studies (see Kasparyan 1973 [1981:49]) suggests that it is not usual in these tribes. The situation is uncertain in Idiogrammatini: despite some speculation by Cushman (1937) and an erroneous citation by Kasparyan (1973 [1981: 49]), the process of oviposition in *Idiogramma* Foerster seems not to have been reported, but eggs have not been found to be carried externally on the ovipositor (A. Bennett pers. comm.).

Thus there remains no evidence that Tryphoninae deploy venom systems that have effects other than to subdue the host while oviposition takes place, although egg-removal experiments have been conducted only for *Netelia* and should be carried out for other tribes. Furthermore the other two known groups of koinobiont ectoparasitic Ichneumonidae, i.e. some Adelogathinae and the *Polysphincta* genus-group, appear to employ pre-oviposition venoms that, as in two of the subgenera of *Netelia* studied here, have only this subduing effect. Adelogathinae consists of the single genus *Adelognathus* Holmgren. One species, *A. chrysopygus* (Gravenhorst) (= *granulatus* Perkins), is a typical idio-biont, employing venom for the permanent paralysis of its host (Rahoo and Luff 1987, confirmed by F.D. Bennett pers. comm.). However, most *Adelognathus* species appear to be koinobionts (Fitton *et al.* 1982), and one thoroughly investigated but undescribed species employs a venom causing temporary paralysis, facilitating oviposition, but which has no other apparent effect: hosts intercepted after paralysis but before oviposition, as also hosts from which eggs were removed, recover to develop to the adult stage normally (Shaw unpublished). In the *Polysphincta* genus-group temporary paralysis of the

host prior to oviposition is probably common to all genera and has been described by Cushman (1926) for *Zatypota parva* (Cresson) and by Eberhard (2000a) for *Hymenoepicnemis argyraphaga* Gauld. In the latter species Eberhard (2000a) found that the venom appears to have no long term effect on host development. This appears to be generally true of the *Polysphincta* genus-group: I have on several occasions reared to adulthood immature spiders bearing parasitoid larvae at the time of collection that for one reason or another subsequently died young, to check that host development was unimpaired, and in every case (involving the parasitoid genera *Polysphincta*, *Dreisbachia* Townes, *Schizopyga* Gravenhorst, *Zatypota* Foerster and *Acrodactyla* Haliday) it was found to be so. Thus, although more investigation of Tryphoninae is warranted, it appears that none of the extant groups of koinobiont ectoparasitic Ichneumonidae employs a venom system with an effect remotely similar to that seen in the cyclostome Braconidae, which seems to have been so important in the evolution of endoparasitism within at least one lineage (Shaw 1983, Whitfield 1992).

Whereas the two studied species of the subgenus *Bessobates* will normally oviposit only on final instar larvae, and one species clearly avoided inactive hosts, the single species studied in the subgenus *Netelia*, *N. (N.) vinulae*, which is unusual in both the subgenus and the genus as a whole for being fully gregarious, preferred hosts in the penultimate instar (see also Ellis 1998) and was very willing to attack them when they were inactive in the proecdysis/apolysis between that and the final instar. Other studied species of the subgenus *Netelia* are solitary, and, although apparently preferring final instar hosts, also commonly oviposit on penultimate instar hosts (Guppy 1961, Danks *et al.* 1979). At least one of the species of the subgenus *Paropheltes* investigated here also seems to be somewhat plastic in this respect.

Species of all three subgenera dumped eggs in the absence of hosts, as has been observed before in the subgenera *Netelia* (Vance 1927) and *Bessobates* (Stenton 1910). This presumably happens because embryonic development is independent of the host, contrary to Stenton's (1910) view, and eggs in these two subgenera (not investigated for *Paropheltes*) can "hatch" even if dumped. The degree of maturity of eggs that are laid on hosts varies considerably and this may have a bearing on the time that elapses before they hatch, although, as dumped eggs tend to dry up without hatching unless kept humid, prevailing humidity is clearly also important and may explain why, in the wild, eggs of many Tryphoninae typically hatch only after the host has constructed its pupation chamber (cf Clausen, 1932). An egg-hatching/larval development response to the conditions of high humidity developing in the host cocoon thus may be the principle means of ensuring the commencement of parasitoid development at the appropriate host stage in Tryphoninae, in contrast to koinobiont ectoparasitoid taxa such as *Rhysipolis* (Shaw 1983) and the eulophid *Eulophus ramicornis* (Fabricius) (Shaw 1981, as *E. larvarum* (Linnaeus)) which achieve this through their venoms. Hosts parasitised by *Netelia* collected while they are still feeding in the wild almost invariably bear only unhatched eggs (pers. obs.), though once brought under captive conditions involving the high humidity of closed containers the eggs frequently hatch, and the larvae start to develop, before the host constructs its pupation chamber. In extreme cases (cf. that illustrated by Ellis 1998 for *N. (N.) vinulae*) this can lead to the host being overwhelmed prematurely and a failure of the parasitoids to survive. The extent to which larval development *per se* may depend on high humidity would be worth investigating.

Guppy (1961) and, possibly following him, Danks *et al.* (1979), writing on species in the subgenus *Netelia*, have stated that

the host's development is "arrested" as a prepupa as the parasitoid starts to feed, but without giving reasons for that conclusion. In one case for one species of the subgenus *Bessobates* studied, two parasitoid larvae on one host were allowed to feed for up to 4 days before they were killed, and the host then went on to pupate normally. In two further cases involving this host and parasitoid species the parasitoid larvae were killed after 6 days, when they were still too small to have caused much damage to the larval hosts, and both hosts then burrowed for pupation but died as prepupae in what seemed to be an arrested state. The interesting possibility that the larva of *Netelia* species does indeed inhibit host development, other than by causing damage merely in the course of feeding, is worthy of further investigation, though it appears not to be capable of this in the earliest days of its feeding. Eberhard (2000a, b) gives evidence of control over the host, apparently through chemicals produced by the parasitoid larva, in *Hymenoepimecis argyraphaga* of the *Polysphincta* genus-group.

The use of mandibles, rather than the ovipositor, to make the wound necessary for non-destructive host-feeding has been noted before in the subgenus *Netelia* (Vance 1927), and was common to all three of the subgenera studied. In one subgenus, *Bessobates*, it appears sometimes (or possibly usually) to involve host individuals other than those used for oviposition, perhaps because a different grip on an subdued host is required. In contrast, in the subgenera *Netelia* and *Paropheltes* non-destructive host-feeding is concurrent (cf. Jervis and Kidd 1986) and normally occurs following each oviposition. The behaviour in *Netelia* s.l. is in marked contrast to that recorded by Simmonds (1947) for *Phytodietus rufipes pulcherrimus* (Cresson), in which feeding was said to take place on the fluids that exuded from the puncture wound (or wounds) made by the ovipos-

itor in the course of injecting venom, and furthermore if the adult fed from the host it did so before ovipositing on it, rather than afterwards as in the subgenera *Netelia* and (normally) *Paropheltes*. Remarkably, Zinnert (1969) noted that *Errormenus calicator* (Müller) (Tryphonini) wounds the host with its mandibles but does not then feed on the exuding haemolymph. Other Ichneumonidae known to make feeding wounds with their mandibles include the tryphonine *Eridolius rufonotatus* (Holmgren) (Exenterinae) (Carl 1976), the pimpline *Exeristes roborator* (Fabricius) (Fox 1927) and an undescribed species of *Adelognathus* (Shaw unpublished). Elsewhere in the Hymenoptera it is known in Eulophidae, Scelionidae and particularly in parasitoid aculeate groups (cf. Jervis and Kidd 1986).

#### ACKNOWLEDGMENTS

I am grateful to Hewett Ellis, Tom Ford and Ray Softly for giving me parasitoid livestock, to Rob Pelly-Jones and English Nature for permission to do fieldwork at Gait Barrows NNR, to the Berkshire, Buckinghamshire and Oxfordshire Naturalist's Trust for allowing my fieldwork on their nature reserves, and to Andy Bennett and David Wahl for constructive reviews of a previous draft.

#### LITERATURE CITED

- Barnard, C. J. and J. M. Behnke (eds). 1990. *Parasitism and Host Behaviour*. Taylor and Francis, London.
- Beckage, N. E. 1985. Endocrine interactions between endoparasitic insects and their hosts. *Annual Review of Entomology* 30: 371–413.
- Beckage, N. E. 1991. Host-parasite hormonal relationships: a common theme? *Experimental Parasitology* 72: 332–338.
- Carl, K. P. 1976. The natural enemies of the pear-slug, *Caliroa cerasi* (L.) (Hym., Tenthredinidae), in Europe. *Zeitschrift für angewandte Entomologie* 80: 138–161.
- Clausen, C. P. 1932. The early stages of some tryphonine Hymenoptera parasitic on sawfly larvae. *Proceedings of the Entomological Society of Washington* 34: 49–60.
- Cushman, R. A. 1913. Biological notes on a few rare or little known parasitic Hymenoptera. *Proceedings of the Entomological Society of Washington* 15: 153–160.
- Cushman, R. A. 1926. Address of the retiring President. *Proceedings of the Entomological Society of Washington* 28: 25–51.
- Cushman, R. A. 1937. The genus *Lysiognatha* Ashmead. *Journal of the Washington Academy of Sciences* 27: 438–444.
- Danks, H. V., R. L. Rabb and P. S. Southern. 1979. Biology of insect parasites of *Heliothis* larvae in North Carolina. *Journal of the Georgia Entomological Society* 14: 36–64.
- Delrio, G. 1975. Révision des espèces ouest-paléarctiques du genre *Netelia* Gray (Hym., Ichneumonidae). *Studi Sassarresi Sez. III., Annali della Facoltà di Agraria dell'Università di Sassari* 23: 1–126.
- Dover, B. A., D. H. Davies and S. B. Vinson. 1988. Dose-dependent influence of *Campoletis sonorensis* polydnavirus on the development and ecdysteroid titers of last-instar *Heliothis virescens* larvae. *Archives of Insect Biochemistry and Physiology* 8: 113–124.
- Eberhard, W. G. 2000a. The natural history and behaviour of *Hymenoepcimecis argyraphaga* (Hymenoptera, Ichneumonidae), a parasitoid of *Plesiometa argyra* (Araneae, Tetragnathidae). *Journal of Hymenoptera Research* 9: 220–240.
- Eberhard, W. G. 2000b. Spider manipulation by a wasp larva. *Nature* 406: 255–256.
- Ellis, H. A. 1998. Observations on the ova and larvae of *Netelia vinulae* (N. cephalotes Holmgren) (Ichneumonidae: Tryphoninae), a gregarious ectoparasitoid of the puss moth caterpillar, *Cerura vinula* L. *Bulletin of the Amateur Entomologist's Society* 57: 145–149 + Plates 98 N-P.
- Fitton, M. G., I. D. Gauld and M. R. Shaw. 1982. The taxonomy and biology of the British Adelognathinae (Hymenoptera: Ichneumonidae). *Journal of Natural History* 16: 275–283.
- Fox, J. H. 1927. The life history of *Exeristes roborator* Fab., a parasite of the European corn borer. *National Research Council Report* (Ottawa) 21: 1–58.
- Gauld, I. D. 1988. Evolutionary patterns of host utilization by ichneumonoid parasitoids (Hymenoptera: Ichneumonidae and Braconidae). *Biological Journal of the Linnean Society* 35: 351–377.
- Guppy, J. C. 1961. Further hymenopterous parasites newly recorded from the armyworm, *Pseudaletia unipuncta* (Haw.) (Lepidoptera: Noctuidae). *Canadian Entomologist* 93: 569–570.
- Jervis, M. A. and N. A. C. Kidd. 1986. Host-feeding strategies in hymenopteran parasitoids. *Biological Reviews of the Cambridge Philosophical Society* 61: 395–434.
- Jones, D. 1987. Material from adult female *Chelonus* sp. directs expression of altered developmental programme of host Lepidoptera. *Journal of Insect Physiology* 33: 129–134.
- Kasparyan, D. R. 1973 [1981]. Fauna of the USSR. Hymenoptera volume 3, number 1. Ichneumonidae (subfamily Tryphoninae) tribe Tryphonini. Oxo-

- nian Press Pvt. 414pp. (1981 English translation of 1973 original in Russian).
- Lawrence, P. O. 1986. Host-parasite hormonal interactions: an overview. *Journal of Insect Physiology* 32: 295–298.
- Leluk, J. and D. Jones. 1989. *Chelonus* sp. near *curvimanulatus* venom proteins: analysis of their potential role and processing during development of host *Trichoplusia ni*. *Archives of Insect Biochemistry and Physiology* 10: 1–12.
- Morris, K. R. S. 1937. The prepupal stage in Ichneumonidae, illustrated by the life-history of *Exenterus abruptorius*, Thb. *Bulletin of Entomological Research* 28: 525–534.
- Quicke, D. L. J. 1997. *Parasitic wasps*. Chapman and Hall, London. 470pp.
- Rahoo, G. M. and M. L. Luff. 1987. The biology of *Adelognathus granulatus* Perkins (Hym., Ichneumonidae) a parasitoid of the small gooseberry sawfly, *Pristiphora pallipes* (Lep.) (Hym., Tenthredinidae). *Journal of Applied Entomology* 104: 480–484.
- Shaw, M. R. 1981. Delayed inhibition of host development by the nonparalysing venoms of parasitic wasps. *Journal of Invertebrate Pathology* 37: 215–221.
- Shaw, M. R. 1983. On[e] evolution of endoparasitism: the biology of some genera of Rogadinae (Braconidae). In Gupta, V. K. (ed.) *Studies on the Hymenoptera. Contributions of the American Entomological Institute* 20: 307–328.
- Shevyrev, I. J. 1912. *Parazity i iz mira nasekomykh* (Parasites and hyperparasites of the insect world). St. Petersburg. 216pp. (In Russian). Cited in Malyshev, S. I. 1966 [1968: 108]. *Genesis of the Hymenoptera and the phases of their evolution*. Methuen. 319pp. (1968 English translation of 1966 original in Russian).
- Simmonds, F. J. 1947. The biology of *Phytodietus pulcherrimus* (Cress.) (Ichneumonidae, Tryphoninae) parasitic [sic] of *Loxostege sticticalis* L. in North America. *Parasitology* 38: 150–156.
- Stenton, R. 1910. On the oviposition and incubation of the ichneumonid *Paniscus (Parabatus) virgatus*, Fourc. *Entomologist* 43: 210–212.
- Strickland, E. H. 1923. Biological notes on parasites of prairie cutworms. *Canadian Department of Agriculture Technical Bulletin* 26. 40pp.
- Tanaka, T. 1987. Calyx and venom fluids of *Apanteles kariyai* (Hymenoptera: Braconidae) as factors that prolong larval period of the host, *Pseudaletia separata* (Lepidoptera: Noctuidae). *Annals of the Entomological Society of America* 80: 530–533.
- Townes, H. 1969. The genera of Ichneumonidae, part 1. *Memoirs of the American Entomological Institute* 11: 1–300.
- Vance, A. M. 1927. On the biology of some ichneumonids of the genus *Paniscus* Schrk. *Annals of the Entomological Society of America* 20: 405–416 + Plate 22.
- Vinson, S. B. and G. F. Iwantsch. 1980. Host regulation by insect parasitoids. *Quarterly Review of Biology* 55: 143–165.
- Wahl, D. B. and I. D. Gauld. 1998. The cladistics and higher classification of the Pimpliformes (Hymenoptera: Ichneumonidae). *Systematic Entomology* 23: 265–298.
- Whitfield, J. B. 1992. The polyphyletic origin of endoparasitism in the cyclostome lineages of Braconidae (Hymenoptera). *Systematic Entomology* 17: 273–286.
- Yu, D. S. and K. Horstmann. 1997. *A Catalogue of World Ichneumonidae. Memoirs of the American Entomological Institute* 58 (1 & 2). 1–1558.
- Zimmert, K.-D. 1969. Vergleichende Untersuchungen zur Morphologie und Biologie der Larvenparasiten (Hymenoptera: Ichneumonidae und Braconidae) mitteleuropäischer Blattwespen aus der Subfamilie Nematinae (Hymenoptera: Tenthredinidae). *Zeitschrift für angewandte Entomologie* 64: 180–217; 277–306.



## INSTRUCTIONS FOR AUTHORS

**General Policy.** The *Journal of Hymenoptera Research* invites papers of high scientific quality reporting comprehensive research on all aspects of Hymenoptera, including biology, behavior, ecology, systematics, taxonomy, genetics, and morphology. Taxonomic papers describing single species are unlikely to be accepted unless a strong case is evident, such as importance in economic entomology or with concurrent biology or ecology. Manuscript length generally should not exceed 50 typed pages; however, no upper limit on length has been set for papers of exceptional quality and importance, including taxonomic monographs at generic or higher level.

All papers will be reviewed by at least two referees. The referees will be chosen by the appropriate subject editor. However, it would be helpful if authors would submit the names of two persons who are competent to review the manuscript.

The language of publication is English. Summaries in other languages are acceptable.

**The deadline for receipt of manuscripts is 1 October (for the April issue) and 1 April (for the October issue).**

**Format and Preparation.** Three copies of each manuscript, including copies of illustrations, should be submitted on letter size or A4 paper, double spaced, with at least 25 mm margins on all sides. On the upper left of the title page give name, address and telephone and fax numbers of the author to whom all correspondence is to be sent.

The paper should have a concise and informative title, followed by the names and addresses of all authors. The sequence of material should be: title, author(s), abstract, text, acknowledgments, literature cited, appendix, figure legends, figure copies (each numbered and identified), tables (each numbered and with heading). Each of the following should start a new page: (1) title page, (2) abstract, (3) text, (4) literature cited, (5) figure legends, (6) footnotes.

Following acceptance of the manuscript, the author should provide the editor with one copy of the manuscript accompanied by a copy on diskette using DD, double sided computer diskettes—IBM compatible MS DOS 5.25 inch or IBM and Macintosh 3.5 inch diskettes. (Authors who do not have access to a computer should submit three copies of the manuscript.) The paper may be submitted in most PC and Mac word processor programs such as Microsoft Word, FullWrite Professional, WordPerfect, WriteNow, Nisus, MacWrite, or MacWrite II. If possible, all words that must be italicized should be done so, not underscored. Tables may be formatted in a spread sheet program such as MS Works or MS Excel. Text should be double-spaced typing, with 25 mm left and right margins. Tables should be put in a separate file. Diskettes should be accompanied by the name of the software program used (e.g., WordPerfect, Microsoft Word). Authors should keep backup copies of all material sent to the Editor. The Society cannot be responsible for diskettes or text mislaid or destroyed in transit or during editing.

Illustrations should be planned for reduction to the dimension of the printed page (14 × 20.5 cm, column width 6.7 cm) and allow room for legends at the top and bottom. Do not make plates larger than 14 × 18 in. (35.5 × 46 cm). Individual figures should be mounted on a suitable drawing board or similar heavy stock. Photographs should be trimmed, grouped together and abutted when mounted. Figure numbers should be on the plate, and it is strongly recommended that names be included after the numbers (e.g., Fig. 2, *texanus*). Include title, author(s) and address(es), and illustration numbers on back of each plate. Original figures need not be sent until requested by the editor, usually after the manuscript has been accepted. Reference to figures/tables in the text should be in the style "(Fig. 1)" "(Table 1)". Measurements should be in the metric system.

All papers must conform to the *International Code of Zoological Nomenclature*. The first mention of a plant or animal should include the full scientific name including the authority. Genus names should not be abbreviated at the beginning of a sentence. In taxonomic papers type specimens must be clearly designated, type depositories must be clearly indicated, and new taxa must be clearly differentiated from existing taxa by means of keys or differential diagnoses. Authors are required to deposit all type material in internationally recognized institutions (not private collections). Voucher specimens should be designated for specimens used in behavioral or autecological studies, and they should be deposited similarly.

Acceptance of taxonomic papers will not require use of cladistic methods; however, authors using them will be expected to specify the phylogenetic program used (if any), including discussion of program options used. A data matrix should be provided if the subject is complex. Cladograms must be hung with characters and these should include descriptors (not numbers alone) when feasible. The number of parsimonious cladograms generated should be stated and reasons given for the one adopted. Lengths and consistency indices should be provided. Adequate discussions should be given for characters, plesiomorphic conditions, and distributions of characters among outgroups when problematical.

References in the text should be (Smith 1999), without a comma, or Smith (1999). Two articles by a single author should be (Smith 1999a, 1999b) or Smith (1999a, 1999b). For multiple authors, use the word "and," not the symbol "&" (Smith and Jones 1999). For papers in press, use "in press," not the expected publication date. The Literature Cited section should include all papers referred to in the paper. Journal names should be spelled out completely and in italics.

**Charges.** Publication charges are \$10.00 per printed page. At least one author of the paper must be a member of the International Society of Hymenopterists. Reprints are charged to the author and must be ordered when returning the proofs; there are no free reprints. Author's corrections and changes in proof are also charged to the author. Color plates will be billed at full cost to the author.

All manuscripts and correspondence should be sent to:

Dr. E. Eric Grissell  
Systematic Entomology Laboratory, USDA  
% National Museum of Natural History  
Washington, DC 20560-0168

Phone: (202) 382-1781 Fax: (202) 786-9422 E-mail: egrissel@sel.barc.usda.gov



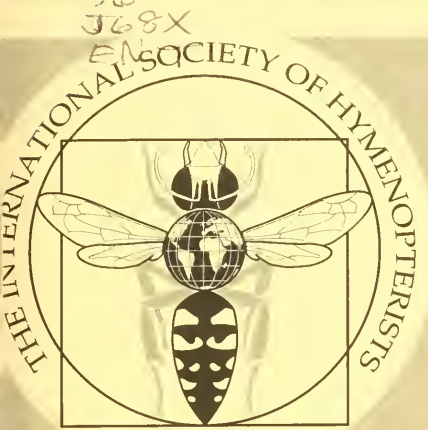

# Journal of Hymenoptera Research

Volume 10, Number 2

October 2001

ISSN #1070-9428

## CONTENTS

- CAETANO, F. H. and F. J. ZARA. Ultramorphology and histology of the foregut and midgut of *Pachycondyla* (= *Neoponera*) *villosa* (Fabricius) larvae (Formicidae: Ponerinae) ..... 251
- GOOLSBY, J. A., C. J. BURWELL, J. MAKINSON, and F. DRIVER. Investigation of the biology of Hymenoptera associated with *Fergusonina* sp. (Diptera: Fergusoninidae), a gall fly of *Melaleuca quinquenervia*, integrating molecular techniques ..... 163
- GRISSELL, E. E. and G. L. PRINSLOO. Seed-feeding species of *Megastigmus* (Hymenoptera: Torymidae) associated with Anacardiaceae ..... 271
- ODA, R. A. M., M. V. DE MACÊDO, and D. L. J. QUICKE. First biological data for *Aspilodemou* Fischer (Hymenoptera: Braconidae: Hydrangeocolinae): parasitoids of cecidomyiid fly galls on Asteraceae in Brazil ..... 126
- OHL, M. The southern African wasp genus *Haudlirschia* Kohl, 1897 (Hymenoptera: Apoidea, Sphecidae, Bembicinae) ..... 231
- PRINSLOO, G. L. The Afrotropical species of *Leptomastidea* Mercet (Hymenoptera: Encyrtidae), parasitoids of mealybugs ..... 145
- QUICKE, D. L. J. and A. PURVIS. A new species of *Streblocera* (*Asiastreblocera*) (Braconidae: Euphorinae) from Thailand with depressed ovipositor ..... 138
- SCHAUFF, M. E. and D. H. JANZEN. Taxonomy and ecology of Costa Rican *Euplectrus* (Hymenoptera: Eulophidae), parasitoids of caterpillars (Lepidoptera) ..... 181
- SCHIFF, N., A. J. FLEMMING, and D. L. J. QUICKE. Spermatodesmata of the sawflies (Hymenoptera: Symphyta): evidence for multiple increases in sperm bundle size ... 119



(Continued on back cover)

# INTERNATIONAL SOCIETY OF HYMENOPTERISTS

Organized 1982; Incorporated 1991

---

## OFFICERS FOR 2001

John LaSalle, *President*  
Lynn Kimsey, *President-Elect*  
James B. Woolley, *Secretary*  
John T. Huber, *Treasurer*  
E. Eric Grissell, *Editor*

---

## Subject Editors

SYMPHYTA AND PARASITICA  
*Biology:* Mark Shaw  
*Systematics:* Donald Quicke

ACULEATA  
*Biology:* Sydney Cameron  
*Systematics:* Wojciech Pulawski

---

All correspondence concerning Society business should be mailed to the appropriate officer at the following addresses: President, CSIRO Entomology, GPO Box 1700, Canberra, ACT 2601, Australia; Secretary, Department of Entomology, Texas A&M University, College Station, Texas 77843; Treasurer, Eastern Cereal & Oilseed Research Centre, Agriculture Canada, K. W. Neatby Building, Ottawa, Ontario, Canada K1A 0C6; Editor, Systematic Entomology Laboratory, USDA, % National Museum of Natural History, 10th and Constitution NW, Washington, D.C. 20560-0168.

**Membership.** Members shall be persons who have demonstrated interest in the science of entomology. Annual dues for members are US\$40.00 per year (US\$35.00 if paid before 1 February), payable to The International Society of Hymenopterists. Requests for membership should be sent to the Treasurer (address above). Information on membership and other details of the Society may be found on the World Wide Web at <http://IRIS.biosci.ohio-state.edu/ish>.

**Journal.** The *Journal of Hymenoptera Research* is published twice a year by the International Society of Hymenopterists, % Department of Entomology, Smithsonian Institution, Washington, D.C. 20560-0168, U.S.A. Members in good standing receive the *Journal*. Nonmember subscriptions are \$60.00 (U.S. currency) per year.

The Society does not exchange its publications for those of other societies.

**Please see inside back cover of this issue for information regarding preparation of manuscripts.**

---

## Statement of Ownership

Title of Publication: Journal of Hymenoptera Research.

Frequency of Issue: Twice a year.

Location of Office of Publication, Business Office of Publisher and Owner: International Society of Hymenopterists, % Department of Entomology, Smithsonian Institution, 10th and Constitution NW, Washington, D.C. 20560-0168, U.S.A.

Editor: E. Eric Grissell, Systematic Entomology Laboratory, USDA, % National Museum of Natural History, 10th and Constitution NW, Washington, D.C. 20560-0168. U.S.A.

Managing Editor and Known Bondholders or other Security Holders: none.

---

## A New Species of the Genus *Orussonia* Riek and the Female of *O. depressa* Riek (Hymenoptera: Symphyta, Orussidae)

STEFAN SCHMIDT AND GARY A. P. GIBSON

(SS) Australian National Insect Collection, CSIRO Entomology, Canberra ACT 2601, Australia (e-mail: Stefan.Schmidt@ento.csiro.au); (GAPG) Systematic Entomology Section, Eastern Cereal & Oilseed Research Centre, Agriculture and Agri-Food Canada, K.W. Neatby Building, 960 Carling Avenue, Ottawa, Ontario, Canada, K1A 0C6 (e-mail: gibsong@em.agr.ca)

---

*Abstract.*—*Orussonia ruficaudata* Schmidt and Gibson, new species, and the female of *O. depressa* Riek are newly described; the male of *O. depressa* is redescribed and differential features of the species and of the sexes of *O. depressa* are illustrated.

---

Riek (1955) established the genus *Orussonia* for two males collected in 1952, which he described as *O. depressa*. One of us (GAPG) recently collected two females that we associate as the opposite sex of *O. depressa*. We also discovered in the Australian National Insect Collection a third female, collected many years earlier in 1919, which Riek had identified as a second undescribed species and labelled with the manuscript name *O. ruficaudata*. Here we describe what we consider to be the female of *O. depressa* and the female of this second species, which we name *O. ruficaudata*.

*Orussonia* is one of three genera of Orussidae occurring in Australia (Riek 1955). The other two genera are *Guiglia* Benson with at least four Australian species (Benson 1955, Riek 1955, Vilhelmsen, pers. comm.) and *Orussobaius* with six species from Australia and one from New Guinea (Schmidt and Vilhelmsen, in prep.). The genus *Orussonia* constitutes, together with genera traditionally placed in the tribe Leporussini by Benson (1955), a paraphyletic group comprising the basalmost lineages of the Orussidae (Vilhelmsen, pers. comm.). Females of species of the genus *Orussonia* possess two pairs of medially separate coronal teeth (Figs 1, 3) and an incomplete ventral transverse frontal carina,

whereas in most other orussid genera there are at least three pairs of medially separate coronal teeth and a fully developed ventral transverse frontal carina (Vilhelmsen, pers. comm.). Among all orussids *Orussonia* is the only genus with an extremely dorsoventrally flattened body and a prognathous head and is, therefore, easily recognisable. Nothing is known about the biology of *Orussonia*, but the flattened body shape might indicate that they crawl under loose bark. It is known for some beetles with dorsoventrally flattened bodies that they occur under bark, e.g. species of the genus *Platysus* (Coleoptera, Cucujidae) (Lawrence and Britton 1991).

### METHODS

The holotype female and male of *O. ruficaudata* and *O. depressa*, respectively, were used for the scanning electron micrographs. All specimens were uncoated and digital images were obtained with a Philips XL 30 ESEM. The low vacuum environmental scanning mode was used for all except Fig. 1, which was obtained under high vacuum. A 1 mm cone aperture was used during low vacuum mode to improve image quality, which resulted in a circular image format at low magnifications. The digital images were enhanced

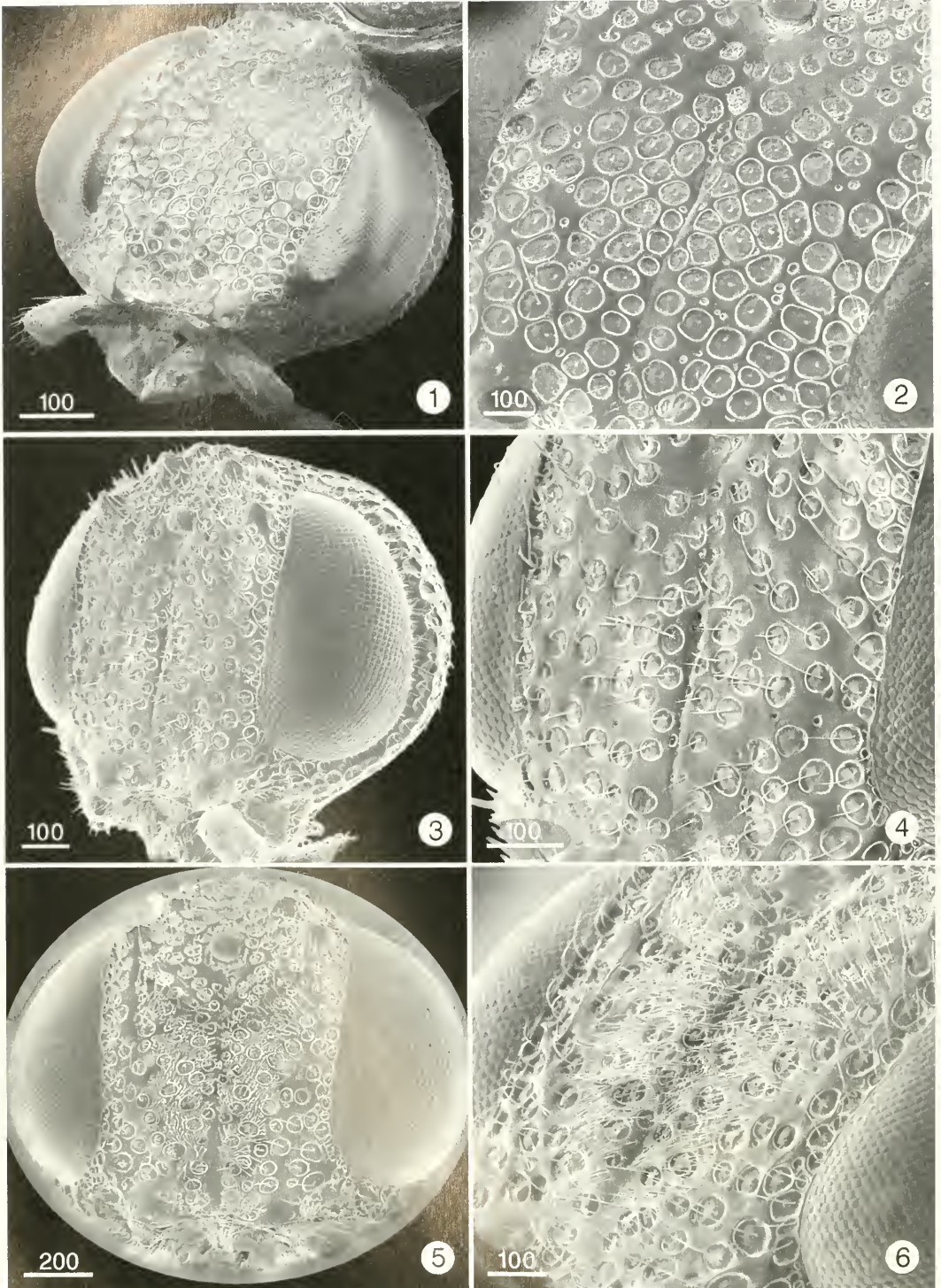

Figs. 1-6. *Orussonia* species. 1-2, *O. ruficaudata*, sp. n.: 1, head, frontolateral view; 2, face. 3-6, *O. depressa* Riek: 3, head of female, frontolateral view; 4, face of female; 5, head of male, frontal view; 6, face of male, frontolateral view. Scale bars =  $\mu\text{m}$ .

and the final plates compiled using Adobe Photoshop<sup>TM</sup>. Figure 10 is a composite of two images and figure 11 is a composite of four images.

### *Orussonia* Riek

*Orussonia* Riek 1955: 104.

Type species: *Orussonia depressa* Riek, by original designation.

*Description*.—Body strongly dorsoventrally depressed, thorax height about half its maximal width measured from above. Head prognathus, occiput strongly excavated and appressed over convex anterior margin of pronotum. Vertex of female with two, of male with three separate pairs of coronal teeth and a less conspicuous, smaller, subcontiguous medial pair dorsally of the lateral ocelli. Female antenna 10-segmented; eighth and ninth segments separated by a fine suture and forming a club; tenth segment peg-like, apically truncate and arising near middle of inner margin of ninth segment. Male antenna filiform, 11-segmented. Antenna about 1.5 × as long as head width, third segment shorter (0.56–0.71) than combined length of fourth and fifth segments, sixth segment slightly longer than third. Face between compound eyes flat with shallow punctures, without longitudinal carinae (Figs. 1–6). Gena rugose. Episto-

mal sulcus absent, ventral transverse frontal carina reflexed and with shallow median incision. Maxillary palp 5-segmented, labial palp 3-segmented. Mesoscutum and scutellum flat, forming a plane; scutellum crenulate along scutoscutellar line but otherwise smooth and shiny except for a few small setiferous punctures (Figs. 7, 8). Axillae punctate-rugose, contiguous medially, separated by a distinct median carina (Figs. 7, 8). Mesopleuron laterally reticulate-rugulose to punctate and setose except for smooth and shiny bare region medially below base of hind wing; ventrally much smoother with scattered setiferous punctures except more coarsely sculptured anterolaterally (Fig. 11). Metafemur swollen, about 2.5 × as long as its maximal width. Forewing hyaline behind stigma but partly infusate basally and apically, with two cubital cells, without intercostal crossvein; anal cell closed, petiolate. Radial cell of forewing and hind wing open apically. Hind wing with large jugal lobe and without closed medial cell. Abdominal tergites 2–5 and 6 basally, laterally carinate; second tergite subequal in length or slightly shorter than combined length of third and fourth tergites.

*Remarks*.—*Orussonia* is readily distinguished from all other orussid genera by its strongly depressed body and prognathus head (Riek 1955, figs. 2, 3).

---

#### KEY TO SPECIES OF *ORUSSONIA* RIEK

- 1 Male and female: face with punctures separated by distinct interspaces, some of which are greater than the diameter of a puncture (Figs. 3–6); abdomen black, apical segment occasionally orange-brown ..... *depressa* Riek  
 – Female: face with punctures nearly contiguous, separated by narrow interspaces (Figs. 1, 2); abdomen black with apical two segments orange-brown ..... *ruficaudata*, new species
- 

### *Orussonia depressa* Riek (Figs. 3–11)

*Orussonia depressa* Riek 1955: 104–5. Holotype ♂, Australia, NSW, 4 miles N. Bateman's Bay, 14.x.1952, E.F. Riek. Type in the Austra-

lian National Insect Collection, Canberra. Paratype ♂, same data as holotype, in The Natural History Museum, London (both examined).

*Additional material examined*. 2 ♀♀, Austra-

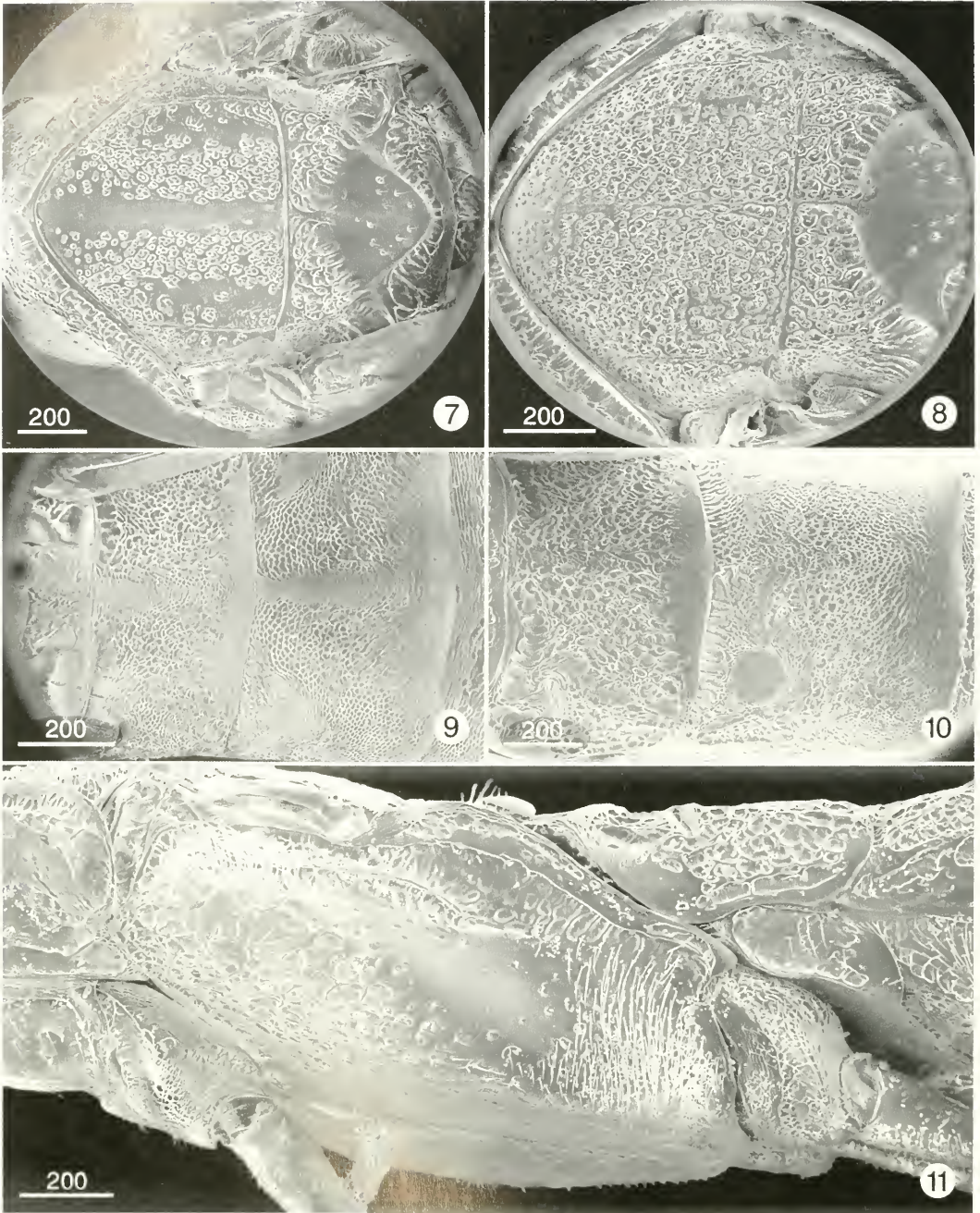

Figs. 7-11. *Orussomia depressa* Riek. 7, female thorax, dorsal view; 8, male thorax, dorsal view; 9, abdominal tergites 1 and 2 of female, dorsal view; 10, abdominal tergites 1 and 2 of male, dorsal view; 11, thorax and base of abdomen of male, ventrolateral view. Scale bars =  $\mu\text{m}$ .

lia, ACT, Canberra, Black Mountain, 2.xi.1998 and 23.x.1998, G.A.P. Gibson. The specimens were collected on dead eucalypt trees. One specimen deposited in ANIC and one in the Canadian National Insect Collection, Ottawa. 1 ♀, Victoria, Red Hill, Oct. 1965, D.R. Holmes, in Oberösterreichisches Landesmuseum, Linz, Austria.

*Female*.—Body length 5–6 mm. Black with following yellowish to orange-brown: labrum and labiomaxillary complex, tenth flagellar segment and sometimes basal three to seven flagellar segments, protibia apically on outer surface, tarsi except apical segment sometimes brown, metatibia dorsomedially, abdominal sternites medially and apical tergite occasionally. Forewing smoky-hyaline with band near base and larger region beyond stigma brownish; stigma black. Face (Figs. 3, 4) flat with shallow, oval to sub-circular punctures separated by smooth, shiny, glabrous interspaces, the largest interspaces greater than diameter of a puncture; punctures each with single seta. Mesoscutum (Fig. 7) punctate-rugose except with shiny, smooth or mostly smooth medial band, and with a less distinct smooth region laterally near parapsidal line. Abdomen with basal two tergites reticulate-rugose except medially and apically smooth to finely coriaceous (Fig. 9); remaining tergites primarily coriaceous but with increasingly obscure, paramedial, transverse punctate-rugose line anteriorly on tergites 3–5.

*Male*.—Similar to female except for following: face (Figs. 5, 6) densely setose medially over region about as wide as clypeus (Fig. 5), flat interspaces with numerous setae originating from distinct setal pores (Figs. 5, 6); mesoscutum (Fig. 8) punctate-rugose except punctate with smooth interspaces anteriorly and with obscure median carina. Second abdominal tergite without medial coriaceous band and with larger and more distinct shiny spot basolaterally (Fig. 10).

*Remarks*.—We consider it likely that the described differences between the sexes are secondary sexual features. This would be consistent with sexual differences found in other orussids. However, we are currently unable to exclude the possibility that the females and males represent separate species. Discovery of the male of *O. ruficaudata* would provide more information on sexual differences among species of *Orussonia*.

***Orussonia ruficaudata* Schmidt and  
Gibson, new species**  
(Figs. 1, 2)

Holotype female: [Australia] "Lakes Entrance, October 1919, V. [Victoria], F.E. Wilson"; "Ex. Coll. Nat. Mus"; "Holotype *Orussonia ruficaudata* Riek"; "manuscript name"; "Holotype *Orussonia ruficaudata* Schmidt & Gibson". Condition of holotype: right antenna missing beyond scape; mounting pin through mesoscutum medially. Type deposited in the Australian National Insect Collection, Canberra.

*Female*.—Body length 8.5 mm. Dark brown to black with following yellowish to orange-brown: labrum and labiomaxillary complex, antenna except segment nine and apical margin of segment eight, tibiae and tarsi except meso- and metatibia darker basally, apical two abdominal segments entirely and sternites 3–5 largely. Forewing hyaline with brownish region behind costal vein and large brownish region beyond stigma; stigma black. Face (Figs. 1, 2) flat with shallow, dense, almost alveolate punctures separated by interspaces which are narrower than diameter of a puncture; punctures each with single seta. Vertex with distinct, dark red coronal teeth. Mesoscutum punctate, punctures of different sizes and partly confluent, and with smooth band medially and paralaterally near parapsidal line. Abdomen with basal two tergites rugulose except medially and apically coriaceous to imbricate; remaining tergites primarily reticulate-coriaceous but with obscure, par-

amedial, transverse punctate-rugose line anteriorly on tergites 3–5.

*Male*.—Unknown.

*Remarks*.—In addition to the two features used to differentiate females of *O. ruficaudata* and *O. depressa* in the key, the single female of *O. ruficaudata* also has more distinctly differentiated punctures on the mesoscutum. The two *O. depressa* females have a more rugose mesoscutum.

#### ACKNOWLEDGEMENTS

We thank Ms Jennifer Read (Eastern Cereal & Oilseed Research Centre) who produced the scanning electron photomicrographs and the plates of illustrations. We also would like to thank Dr. Lars Vilhelm-

sen (Department of Systematic Zoology, Uppsala, Sweden) for discussing orussid relationships. A specimen for this study was provided by Dr. Fritz Gusenleitner (Oberösterreichisches Landesmuseum, Linz, Austria).

#### LITERATURE CITED

- Benson, R. B. 1955. Classification of the Orussidae with some new genera and species (Hymenoptera; Symphyta). *Proceedings of the Royal Entomological Society of London (B)* 24, 13–23.
- Lawrence, J.F. and E.B. Britton. 1991. Coleoptera. In: CSIRO Entomology (Ed.). *The Insects of Australia*. Second Edition. Melbourne University Press, Melbourne, pp. 543–683.
- Riek, E.F. 1955. The Australian sawflies of the family Orussidae (Hymenoptera, Symphyta). *Australian Journal of Zoology* 3: 99–105.

## Spermatodesmata of the Sawflies (Hymenoptera: Symphyta): Evidence for Multiple Increases in Sperm Bundle Size

NATHAN SCHIFF, ANTHONY J. FLEMMING, AND DONALD L. J. QUICKE

(NS) U.S. Forest Service, Southern Research Station, Center for Bottomland Hardwoods Research, P.O. Box 227, Stoneville, MS 38776, USA; (AJF) Department of Biology, Imperial College at Silwood Park, Ascot, Berkshire SL5 7PY, U.K.; (DLJQ) Unit of Parasitoid Systematics, Department of Biology, Imperial College at Silwood Park, Ascot, Berkshire SL5 7PY, UK, and Department of Entomology, The Natural History Museum, London SW7 5BD, UK

---

*Abstract.*—We present the first survey of spermatodesmata (bundles of spermatozoa connected at the head by an extracellular ‘gelatinous’ matrix) across the sawfly superfamilies. Spermatodesmata occur in all examined taxa within the sawfly grade (Xyelidae–Orussidae inclusive), but are not found in the Apocrita. Using DAPI staining, the numbers of individual sperm per spermatodesm were calculated and the values obtained are mapped on to the current phylogenetic hypothesis. The plesiomorphic spermatodesm in the Hymenoptera, based on that observed in the putatively basal family Xyelidae, contains relatively few sperm, approximately 16. However, in the Tenthredinoidea and in the Siricidae, far larger numbers are found, reaching up to 256 in the Cimbicidae.

---

In many insects, mature sperm released from testicular follicles are neither free individuals nor packaged into variously complex spermatophores, but are arranged in organised bundles with their anterior ends embedded in an extracellular cap. These structures, called spermatodesmata (spermatodesm singular), occur, amongst others, in at least some members of the Collembola, Orthoptera, Diptera, Coleoptera, Lepidoptera and Hymenoptera (Jamieson 1987). Within the Hymenoptera, spermatodesmata appear to be limited to the basal sawflies (Quicke et al. 1992, Quicke 1997), and they have not been observed in members of the ‘Evaniomorpha’ (Stephanoidea, Megalyroidea, Evanioidea and Ceraphronoidea examined), proctotrupoid *sensu lato* (Diapriidae, Proctotrupidae, Heloridae and Scelionidae examined), chalcidoid, cynipoid, ichneumonoid or aculeate groups (Quicke et al. 1992, Newman and Quicke 1998, 1999a,b, 2000, Lino-Neto et al. 1999, 2000a,b).

Until now, spermatodesmata have only been characterised in a few sawflies, almost entirely as part of ultrastructural investigations using transmission electron microscopy (Quicke et al. 1992, Newman and Quicke 1999a), but the data obtained are not normally easily interpreted in terms of the actual size and structure of the spermatodesm. However, it was apparent that spermatodesmata vary in both size (i.e. number of individual sperm involved) and shape. For example, in most taxa examined the spermatodesmata resemble a tuft of grass with their acrosomes embedded in an extracellular cap and the nuclei and tails splaying out posteriorly. However in the cephid, *Cephus pygmaeus*, the whole spermatodesm is very elongate, several times longer than an individual sperm, and sperm are inserted along a thin central extracellular matrix core (Quicke et al. 1992).

Sperm produced in a given follicle are all derived from cell divisions from a sin-

gle spermatogonial cell (see Quicke 1997). Because these cell divisions occur synchronously within a follicle and each sperm mother cell in each follicle undergoes a fixed number of cell division rounds, the numbers of sperm per spermatodesm are expected to be  $2^n$  where  $n$  is the number of rounds of spermatocyte division.

Counting the numbers of sperm in each spermatodesm was not straight-forward for most taxa because when stained using traditional dyes, the mass was so opaque with overlapping nuclei and tails that individual cells could not be distinguished and counted. We have therefore employed a fluorescence staining technique in order to measure the total DNA content of the spermatodesm and divided that by the DNA content of an individual sperm nucleus. For a few taxa that were no longer available for the current study, we have included some crude estimates of sperm number obtained from transmission electron microscopy of transverse sections (Quicke et al. 1992, Newman and Quicke 1999a). However, these are likely to be underestimated, because more posteriorly inserted sperm may not have been sectioned.

#### MATERIALS AND METHODS

*Materials.*—The following taxa were examined. Xyelidae: *Xyela* sp., Colorado; Tenthredinidae: *Tentiredo xantha* Norton, N California; *Strongylogaster distans* Norton, S California; *Dolerus tejonensis* (Norton), S California; Pergidae: *Acordulecera* sp., Illinois; Cimbicidae: *Trichiosoma triangulum* (Kirby), NW California; *Cimbex americanum* Leach, NW California; Anaxyelidae: *Syntexis libocedrii* Rohwer, California; Xiphidriidae: *Xiphidria abdominalis* Say, Illinois; *Xiphidria maculata* Say, Illinois; Orussidae: *Orussus thoracicus* (Ashmead), N California; *Orussus occidentalis* (Cresson), N California. It should be noted that males of many sawflies are taxonomically difficult to segregate and at present species-level identifications are not always

possible. Voucher specimens have therefore been deposited in the United States National Museum (Washington D.C.).

*Light microscopy.*—Vas deferentia and testes were dissected from living sawflies in insect saline (Clark et al. 1979) and teased apart on a clean microscope slide. After a few minutes to allow the sperm/spermatodesmata to swim free of the disrupted tissue, the slides were heat fixed on a hot plate at approximately 80°C. These slides were stained with a 0.007mg/ml solution of 4',6-diamidino-2-phenylindole dihydrochloride (DAPI) and viewed with a Leitz epifluorescence microscope at  $\times 1000$  (as in Flemming *et al.* 2000). This stain specifically binds to double stranded DNA and fluoresces under UV light (Figs. 1, 2). Images of stained spermatodesmata were captured using a CV-M300 video camera, and a Scion LG3 frame-grabber mounted in a Power Macintosh running Scion Image 1.62a. Care was taken to ensure that, in each frame, both a complete spermatodesm and an isolated sperm cell was present (This was not possible for *Acordulecera* where only one isolated sperm nucleus could be found). Before capturing, the image was adjusted to minimise pixel saturation and these adjustments affected the spermatodesm and isolated sperm cell in each image equivalently. A densitometric value for both the spermatodesm and the sperm nucleus was determined (the product of area measured in pixels and staining intensity) and the number of sperm in the spermatodesm derived by dividing the two values. On average four images per species were analysed. For one species, *Xiphidria maculata*, it was possible to make a direct count of sperm nuclei present in the spermatodesm. Comparison of this value with that obtained densitometrically ( $35 \pm 7$  (95% confidence interval) and  $33 \pm 3$  (95% confidence interval) respectively) confirms the accuracy of the technique. Basic statistics were calculated using Excel 98 (Microsoft).

Making the assumption that DNA

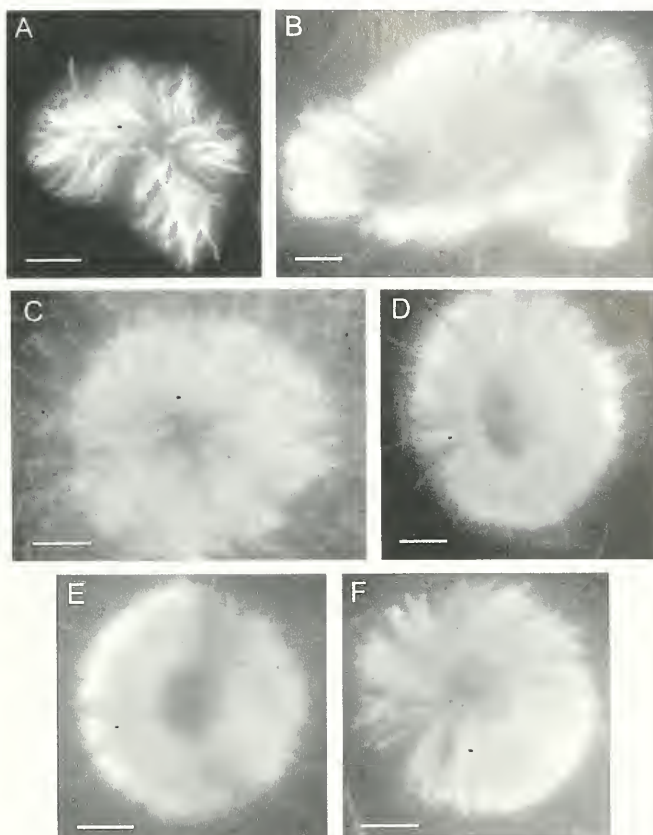

Fig. 1. Fluorescence images of DAPI-stained sperm nuclei in spermatodesmata of sawflies investigated: A, *Acordulecera* sp. (Pergidae); B, *Trichiosoma triangulum* (Cimbicidae); C, *Strongylogaster distans* (Tenthredinidae); D, *Dolerus tejonensis* (Tenthredinidae); E, *Tenthredo xantha* (Tenthredinidae); F, *Cimbex americanum* (Cimbicidae).

(chromatin) is densely packed in sperm nuclei, and since we have no *a priori* reasons to expect differences in DNA density between taxa, we used sperm nucleus size as a surrogate for haploid DNA content.

## RESULTS

The sperm heads are inserted throughout the cap of the spermatodesmata, with those sperm located more centrally being inserted more anteriorly (Figs. 1, 2). For Xyelidae, Anaxyelidae, Xiphydriidae and Orussidae, the spermatodesmata are elongate structures, in the case of *Orussus*, the sperm appear to be inserted in the cap in a spiral configuration rather as if a cylindrical roll of paper was 'pulled out' from

the middle. Tenthredinoid spermatodesmata are far wider and the larger ones (i.e. those with a larger number of sperm; Fig. 1a,b,f) dry on to the slides as rosette like structures. Although the centres of these appear empty in DAPI-stained material, transmission electron micrographs (Newman and Quicke 1999a) suggest that this is the region where the acrosomes are inserted in the extracellular matrix of the cap.

Results of numbers of sperm per spermatodesm are shown graphically in Fig. 3. Visual inspection of numbers (which as explained above are expected to be integer powers of 2) suggests that for *Xyela*, the number is 16, for Orussidae, Anaxyelidae

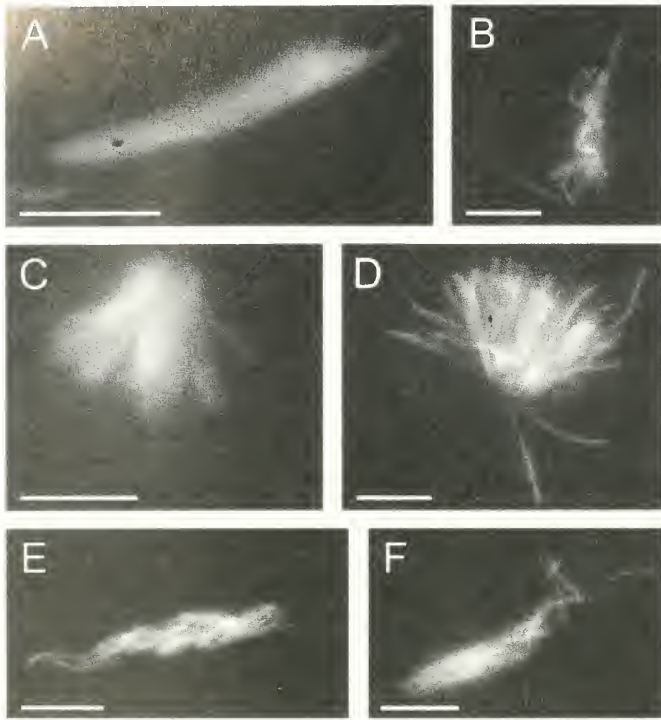

Fig. 2. Fluorescence images of DAPI-stained sperm nuclei in spermatodesmata of sawflies investigated: A, *Xyela* (Xyelidae); B, *Syntexis libocedrii* (Anaxyelidae); C, *Xiphydria abdominalis* (Xiphydriidae); D, *Xiphydria maculata* (Xiphydriidae); E, *Orussus occidentalis* (Orussidae); F, *Orussus thoracicus* (Orussidae).

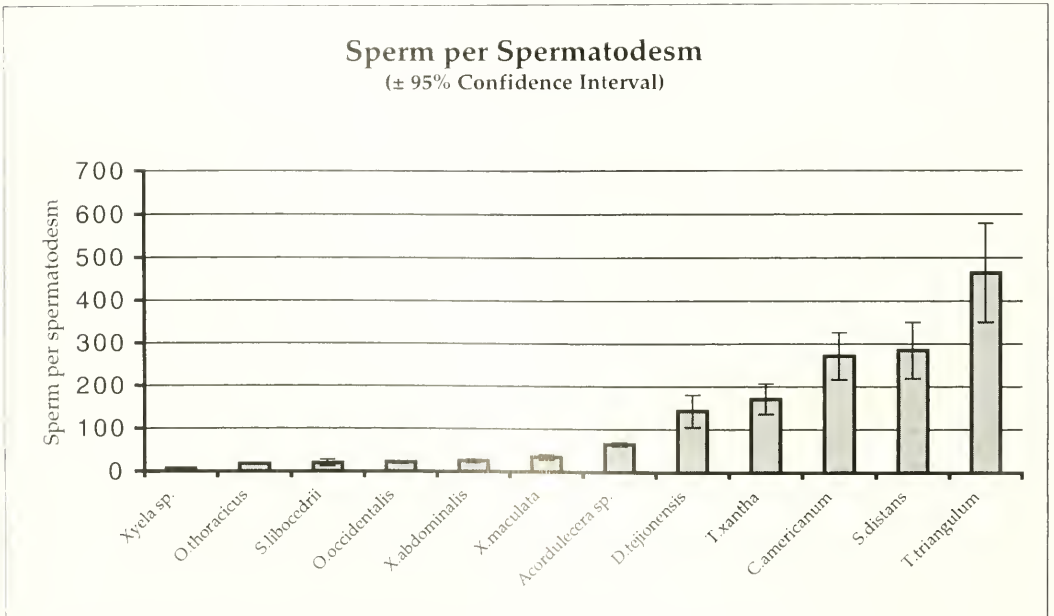

Fig. 3. Plot of numbers of sperm per spermatodesm for sawfly taxa ranked according to spermatodesm size.

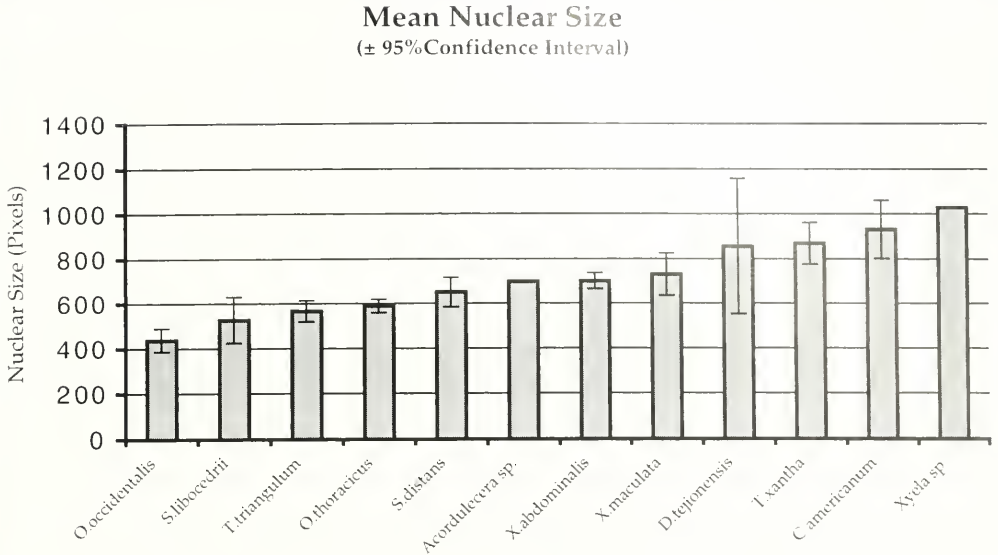

Fig. 4. Plot of mean nucleus size, a surrogate for DNA content, for individual sperm in each sawfly taxon.

and Xiphydriidae, it is 32, for Tenthredinidae the number ranges from 128 to 256, for Pergidae 64 and for Cimbicidae, 256–512. Visual inspection of toluidine blue stained slides of two other tenthredinids (*Rhogogaster californica* (Norton) and a *Tenthredo* that was either *T. lacticineta* Cresson or *T. varipicta* Norton) suggests that they have the same number of sperm per spermatodesm as *T. xantha*.

Counts of the number of pixels occupied by isolated sperm nuclei (Fig. 4) allow us to estimate nuclear DNA content. The distribution is suggestive of a trend among the sawflies in that *Xyela*, the most basal genus, has the largest nucleus and *Orussus*, the most derived genus has the smallest nucleus.

Although we have not been able to utilise the present technique to quantify spermatodesm size in the Cephoidea or Sirocidae, inspection of the stained light micrographs and of transmission electron micrographs for these two superfamilies respectively (Quicke et al. 1992, Newman and Quicke 1999a) indicate that both of

these have rather large numbers of sperm per spermatodesm. Our best estimates were taken as the smallest power of two larger than the definite minimum number of individual sperm within a micrograph of a spermatodesm. The sperm tails are relatively straight for a distance after emerging from the sperm head and in our micrographs the spermatodesmata were reasonably isolated so we do not believe that there is any reason why that sperm number will have been over-estimated. For the cephid, *Cephus*, this is 128 (based on a count of 93 sperm tails), and for the siricid, *Tremex*, it is 512 (based on a count of c. 400 transverse sections of sperm in a largely complete micrograph section).

#### DISCUSSION

Given that we now have a robust phylogenetic hypothesis for the superfamilies of sawflies and at least an estimate of family level relationships within the tenthredinoid lineage (Vilhelmsen 1997, 2000a,b, 2001), we can consider the evolutionary pattern of spermatodesm size (number of

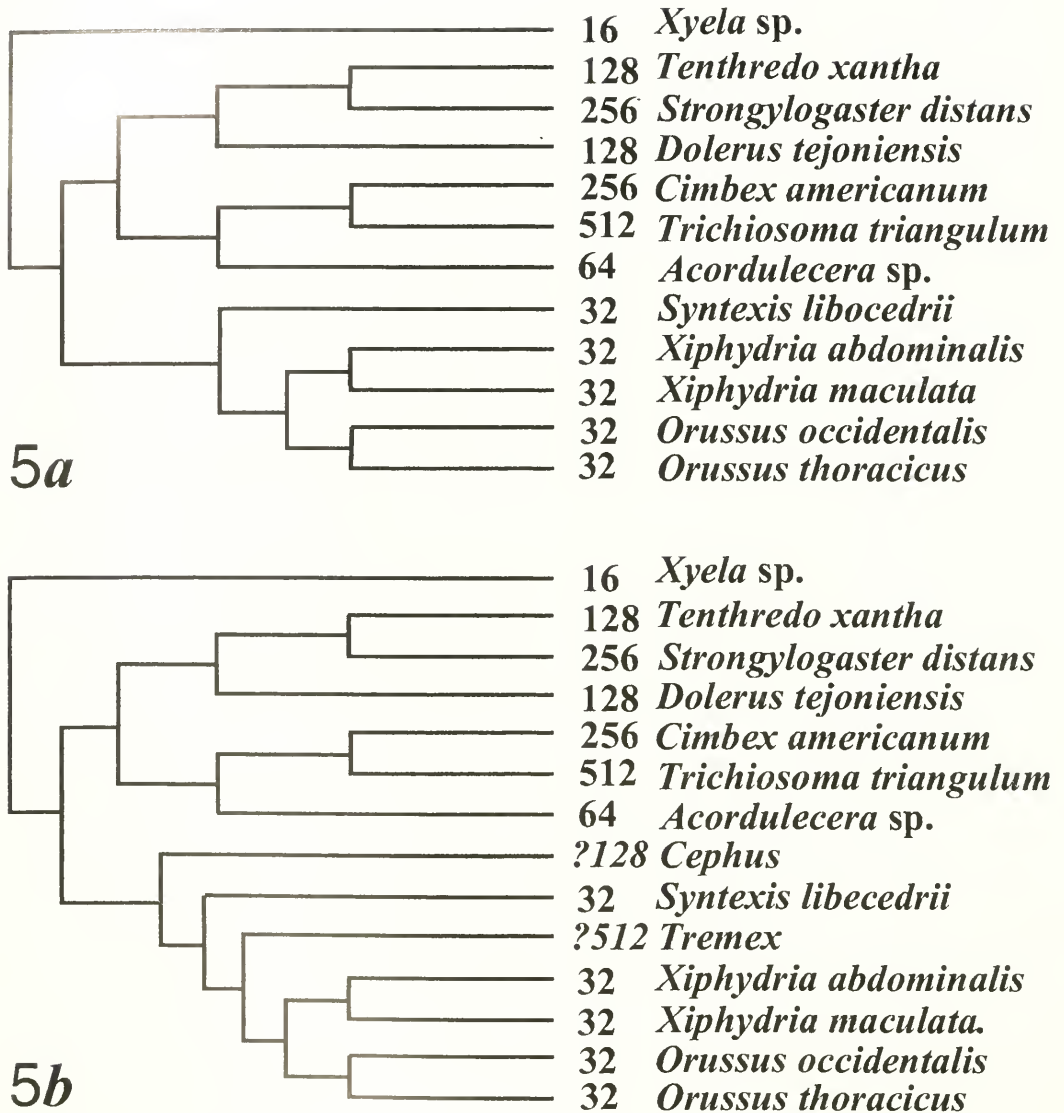

Fig. 5. Number of sperm per spermatodesm shown on the independently obtained cladogram of sawfly relationships (from Vilhelmsen 1997, 2001), showing in (a) only data obtained from DAPI-staining, and (b) with values for additional taxa based on other estimation techniques incorporated.

sperm included). Unfortunately, there is considerable uncertainty about what constitutes a suitable outgroup for the Hymenoptera, and if one accepts a currently common view that the order is the sister group of the remainder of the Holometabola, then there is too much variation with this putative sister group to use it as an outgroup for the purposes of the current

analyses. Therefore we base our interpretations on the likely ancestral state in the order on the state shown by the Xyelidae which display the most putatively plesiomorphic character states of any of the extant Hymenoptera. Visual inspection of the DAPI sperm-quantification data mapped on to Vilhelmsen's (*loc. cit.*) independently derived sawfly phylogeny

(Fig. 5a) suggests that the groundplan spermatodesm size for sawflies is low (16 or 32), but that there has been a general increase within the Tenthredinoidea (range 64–512) and that particularly large numbers (256–512) have evolved at least twice within this superfamily. However, incorporating estimates of sperm number for *Cephus pygmeus* (Cephoidea) and *Tremex* sp. (Siricidae) into Vilhelmsen's phylogeny (*loc. cit.*) (Fig. 5b) tends to confuse the picture in that it is equally parsimonious that there was a marked increase in sperm number per spermatodesm above the Xyelidae, and that there were reversals to lower numbers in the Anaxyelidae and Xiphydriidae + Orussidae as for multiple increases from a groundplan of 16 or 32 (*viz* in the Tenthredinoidea, Cephoidea and Siricidae).

Denser taxon sampling may help to clarify the above issues and may also provide additional phylogenetic evidence within some groups, especially within the Tenthredinoidea. Future work will examine nuclear DNA content across the Hymenoptera in more detail (Schiff, Flemming and Quicke in preparation).

#### ACKNOWLEDGEMENTS

We would like to thank Virginia Scott for sending us the live male *Xyela*, David Smith for comparing the *Tenthredo* voucher specimens with the USNM (Washington DC) reference collection, and Larry Bezark and Steve Heydon for helping and providing NS with company on some of the collecting trips.

#### LITERATURE CITED

- Clark, R. B., K. A. F. Gration and P. N. R. Usherwood. 1979. Desensitization of glutamate receptors on innervated and denervated locust muscle fibres. *Journal of Physiology (London)* 290: 551–568.
- Flemming, A. J., Z. Z. Shen, A. Cunha, S. U. Emmons and A. M. Leroi. 2000. Somatic polyploidisation and cellular proliferation drive body size evolution in nematodes. *Proceedings of the National Academy of Sciences, USA*, 97: 5285–5290.
- Jamieson, B. G. M. 1987. *The Ultrastructure and Phylogeny of Insect Spermatozoa*. Cambridge University Press, Cambridge, 320pp.
- Lino-Neto, J., S. N. Bao, and H. Dolder. 1999. Structure and ultrastructure of the spermatozoa of *Beprinatelloides pomorum* (Fabricius) (Hymenoptera: Eurytomidae). *International Journal of Insect Morphology and Embryology* 28: (4): 253–259.
- Lino-Neto, J., S. N. Bao, and H. Dolder. 2000a. Structure and ultrastructure of the spermatozoa of *Trichogramma pretiosum* Riley and *Trichogramma atopovirilia* Oatman and Platner (Hymenoptera: Trichogrammatidae). *Acta Zoologica, Stockholm* 81: 205–211.
- Lino-Neto, J., S. N. Bao, and H. Dolder. 2000b. Sperm ultrastructure of the honey bee (*Apis mellifera*) (L) (Hymenoptera, Apidae) with emphasis on the nucleus-flagellum transition region. *Tissue and Cell* 32: 322–327.
- Newman, T. M. and D. L. J. Quicke. 1998. Sperm development in the imaginal testes of *Aleiodes coxalis* (Hymenoptera: Braconidae: Rogadinae). *Journal of Hymenoptera Research* 7: 25–37.
- Newman, T. M. and D. L. J. Quicke. 1999a. Ultrastructure of imaginal spermatozoa of sawflies (Insecta: Hymenoptera: Symphyta). *Journal of Hymenoptera Research* 8: 35–47.
- Newman, T. M. and D. L. J. Quicke. 1999b. Ultrastructure of spermatozoa in *Leptopilina* (Hymenoptera: Cynipoidea: Eucoilidae). *Journal of Hymenoptera Research* 8: 197–203.
- Newman, T. M. and D. L. J. Quicke. 2000. Sperm development and ultrastructure of mature spermatozoa of *Megalyra* (Hymenoptera: Megalyroidea). *Journal of Hymenoptera Research* 9: 62–70.
- Quicke, D. L. J. 1997. *Parasitic Wasps*. Chapman & Hall, London, 470pp.
- Quicke, D. L. J., S. N. Ingram, H. S. Baillie and P. V. Gaitens. 1992. Sperm structure and ultrastructure in the Hymenoptera (Insecta). *Zoologica Scripta* 21: 381–402.
- Vilhelmsen, L. 1997. The phylogeny of lower Hymenoptera (Insecta), with a summary of the early evolutionary history of the order. *Journal of Zoological Systematics and Evolutionary Research* 35: 49–70.
- Vilhelmsen L. 2000a. Before the wasp-waist: Comparative anatomy and phylogenetic implications of the skeleto-musculature of the thoraco-abdominal boundary region in basal Hymenoptera (Insecta). *Zoology* 119: 185–221.
- Vilhelmsen L. 2000b. The ovipositor apparatus of basal Hymenoptera (Insecta): phylogenetic implications and functional morphology. *Zoologica Scripta* 29: 319–345.
- Vilhelmsen L. 2001. Phylogeny and classification of the extant basal lineages of the Hymenoptera (Insecta). *Zoological Journal of the Linnean Society* 131: 393–442.

## First Biological Data for *Aspilodemon* Fischer (Hymenoptera: Braconidae: Hydrangeocolinae): Parasitoids of Cecidomyiid Fly Galls on Asteraceae in Brazil

RUBENS A. M. ODA, MARGARETE VALVERDE DE MACÊDO, AND DONALD L. J. QUICKE

(RAMO, MVM) Laboratório de Ecologia de Insetos, Departamento de Ecologia, CP 68020, Instituto de Biologia, Universidade Federal do Rio de Janeiro, Rio de Janeiro CEP 21941-590, Brazil; (DLJQ) Unit of Parasitoid Systematics, Department of Biology, Imperial College at Silwood Park, Ascot, Berkshire SL5 7PY, U.K., and Department of Entomology, The Natural History Museum, London SW7 5BD, UK

---

*Abstract.*—Biological data for the hydrangeocoline braconid genus *Aspilodemon* Fischer are reported for the first time. An *Aspilodemon* sp. from Brazil is reported as a parasitoid of three species of *Liodiplosis* spp. (Diptera: Cecidomyiidae) which induce galls on leaves of the liana, *Mikania glomerata* (Asteraceae); it does not attack other gall-forming cecidomyiids on the same plant, and evidence suggests that it is ectoparasitic although direct observations of parasitoid larvae have not been made. How this affects our understanding of the evolution of gall formation and aphid parasitism by braconids is discussed.

---

The Hydrangeocolinae are a recently recognised subfamily of braconid wasps (Dowton et al. in press, Belshaw and Quicke in press), to date known from three genera, each with a southern distribution, viz *Hydrangeocola* Brèthes (= *Kephalosema* Fischer) from Chile, *Aspilodemon* Fischer, from Central and South America and *Opiopterus* Szépligeti (see Wharton 1993, Whitfield and Wharton 1997), from Australia. Until recently, some of these taxa were typically treated under the subfamily Opiinae (e.g. Fischer 1966, but see Wharton 1988) or more recently the Hormiinae, see e.g. Whitfield and Wharton (1997) or Rhyssalinae (Quicke et al. 1997) though several of these authors recognised, they do not fit well into any of these (see electronic appendix of Belshaw et al. 2000 for further discussion). Interest in the group was recently increased because molecular sequence data strongly indicate that they are not related to Opiinae, Hormiinae or Rhyssalinae, but instead form a sister group to the endemic Australian subfamily, Mesostoinae, and that together

these are the sister group of the well known Aphidiinae (Belshaw et al. 2000). This newly discovered relationship was particularly interesting as it appeared to suggest both a Gondwanan origin of the Aphidiinae despite their currently predominantly northern distribution, and a link with galls, because the most primitive extant aphids are gall formers, mesostoinae braconids form galls on *Banksia* spp. (Proteaceae) (Austin and Dangerfield 1998) and the only hydrangeocoline for which some biology is known, *Hydrangeocola*, has been reared from unidentified galls on *Hydrangea* (Hydrangeaceae) (Brèthes 1927). Very little is known, however, about the biologies of the putatively most primitive extant aphidiines, and a direct association of any these with gall-forming aphids is yet to be confirmed.

Here we present the first rearing data for the genus *Aspilodemon* based on a probably undescribed species from Brazil. The species concerned is associated with cecidomyiid fly galls on *Mikania glomerata* Sprengel, and the available evidence

Table 1. Number of galls collected in each locality during study; gall types are illustrated in Gagné et al. (2001).

Locality	Morphological type of gall						
	Cylindrical	Spherical	Conical	Leaf/Vein	Bud	Epidermis	Stem
Parati	2070	1085	0	885	5	53	27
Itatiaia	1385	468	0	574	11	17	22
Poço	1061	583	17	272	5	17	0
Picinguaba	861	471	188	305	2	38	9
S. Órgãos	297	361	0	252	2	20	56
Tijuca	0	6	824	51	0	141	0

strongly suggests that it is a parasitoid of the fly larva. *M. glomerata* is a liana species belonging to the Asteraceae, and it occurs inside and on the edges of forests, flowering from August to December. The genus *Mikania* has 415 species mainly distributed in Central and South America, of which 171 species occur in Brazil (King and Robinson 1987). *M. glomerata* ranges from north-eastern Brazil down to the southern-most part of Brazil and just into Argentina and Paraguay (Ritter et al. 1992).

### MATERIALS

Voucher specimens of the *Aspilodemon* sp. reared are deposited in each of the following collections: The Natural History Museum, London; the Entomological Collection of the Laboratório de Ecologia de Insetos, Department of Ecology, Universidade Federal do Rio de Janeiro. Morphological terminology follows Sharkey and Wharton (1997). The D2-D3 28S rDNA gene sequence for the species of *Aspilodemon* referred to here is deposited in EMBL: accession number AJ245685 (and has been used in phylogenetic analyses of Belshaw et al. 2000 and Quicke and Belshaw 1999).

*Study areas and sampling.*—The research was based in the Atlantic coast (Mata Atlântica) forests of Brazil which has one of the highest levels of biological diversity in the world, and is representative of humid tropical forests and their associated ecosystems (Mori et al. 1981). The localities were (1) Itatiaia National Park, Itatiaia

County, Rio de Janeiro State; (2) Serra dos Órgãos National Park, Teresópolis County, Rio de Janeiro State; (3) Tijuca National Park, Rio de Janeiro County, Rio de Janeiro State; (4) Parati County, Rio de Janeiro State; (5) Picinguaba State Park, Ubatuba County, São Paulo State; (6) Biological Reserve of Poço das Antas, Silva Jardim County, Rio de Janeiro State. Four collections of galls (one per season—one day in the field) were made at each of the first five of the above localities: April or May, 1998 (Autumn), July or August 1998 (Winter), October or November 1998 (Spring) and January or February 1999 (Summer). The sixth locality was sampled at monthly intervals from February 1996 to October 1997. Total numbers of each type of gall collected at each field site are given in Table 1.

Eight species of cecidomyiid flies form galls on *Mikania glomerata* in Brazil, and the galls of most of these can be distinguished on the basis of their morphology and location on the plant (Table 2) (see Gagné et al. 2001, in which gall types are also illustrated). Cecidomyiid galls were collected from *M. glomerata* plants at six localities and reared to discover what parasitoids might be attacking them. Some galls were dissected.

### OBSERVATIONS

*Rearings of Aspilodemon.*—Rearings are summarized in Table 3. The numbers of each type of gall collected at each locality (Table 1) are estimates of their relative

Table 2. Cecidomyiid fly galls found on *Mikania glomerata* (Asteraceae) with descriptions of gall location and type.

Super-tribe Cecidomyiidi	
<i>Mikaniadiplosis annulipes</i> (Gagné)—leaf vein swelling	
Tribe Clinodiplosini	
<i>Liodiplosis cylindrica</i> Gagné—cylindrical leaf gall	
<i>L. conica</i> Gagné—conical leaf gall	
<i>L. spherica</i> Gagné—spherical leaf gall	
Tribe Asphondyliini	
<i>Asphondylia glomeratae</i> Gagné—vein swelling	
<i>A. moehni</i> Skuravá—stem swelling	
<i>Perasphondylia mikaniae</i> Gagné—bud gall	
Super-tribe Lasiopteridi	
Tribe Alycaulini	
<i>Alycaulus globulus</i> Gagné—leaf epidermis swelling	

abundance, and therefore it is clear that although the cylindrical gall type was more abundant by approximately a factor of 2 at the three localities from where most individuals of *Aspilodemon* were obtained (Parati, Picinguaba and Poço), the *Aspilodemon* demonstrated a clear preference for the spherical gall type which yielded proportionately far more wasps (Table 3).

Except for the only individual obtained from the leaf vein swelling or vein swelling (we could not differentiate these two gall types) at Picinguaba, all *Aspilodemon* individuals were obtained from the galls induced by species of *Liodiplosis*. As we collected and reared many galls it is possible that the individual supposed to have been obtained from leaf vein swelling or vein swelling is a contamination.

Numerous Chalcidoidea were reared from the three gall types attacked by *Aspilodemon*; at least 10 species from the conical leaf gall type alone (taking all localities and sampling dates into account). The importance of *Aspilodemon* as a parasitoid (in terms of parasitism rate) varied: it was the commonest parasitoid reared from the spherical and conical leaf galls and the fourth commonest in the cylindrical gall.

*Evidence that Aspilodemon is a parasitoid*

Table 3. Total *Aspilodemon* rearings from cecidomyiid galls on *Mikania glomerata* at each site.

Locality	Morphological type of gall			
	Cylindrical	Spherical	Conical	Leaf/Vein
Parati	19	65	0	0
Itatiaia	1	0	0	0
Poço	2	44	3	0
Picinguaba	4	9	2	1
S. Órgãos	0	2	0	0

and not a gall-former.—*Aspilodemon* individuals were always found inside Cecidomyiidae gall chambers, and all the types of gall found (Table 1) yielded cecidomyiid flies showing that no gall type yielded only *Aspilodemon* and no potential hosts. Further, the *Aspilodemon* species was associated with three morphologically different gall types which would not be expected if it was a gall inducer itself.

*Evidence that Aspilodemon may be ectoparasitic.*—*Aspilodemon* pupates inside a cocoon which occupies approximately half of the cecidomyiid chamber. All the endoparasitoids that were also reared (see above) pupated inside the cecidomyiid skin and we could find the cecidomyiid larval sternal spatula (a strongly sclerotised thoracic feature) within the galls after these endoparasitoids had emerged. When *Aspilodemon* parasitised the cecidomyiid no host remains could be found, perhaps indicating that the sternal spatula had been consumed.

## DISCUSSION

The discovery that *Aspilodemon* is associated with galls strengthens the possibility that this way of life is the norm for the subfamily Hydrangeocolinae. Previously published suggestions that *Aspilodemon* belongs to the Opiinae (Fischer 1966) have been superseded by both morphological (Wharton 1988, Whitfield 1993) and molecular phylogenetic analyses (Belshaw et al. 2000), which instead support a relationship with the Australian subfamily Mesostoinae and also with the Aphidiinae.

Several transitions to cecidogenesis have occurred in the Braconidae: Mesostoinae appear to be exclusively cecidogenic on *Banksia* species (Proteaceae) (Quicke and Huddleston 1989, Austin and Dangerfield 1998); the enigmatic genus *Monitoriella* Hedqvist produces galls on *Philodeudron* (Liliaceae) (Infante et al. 1995); several species of the doryctine genus *Alorhogas* Gahan (Macêdo and Monteiro, 1989; Marsh et al. 2000), and another doryctine, *Psenobolus*, is an inquiline in figs (Ramirez and Marsh 1996) and may be partly cecidogenic. Knowledge that at least some Hydrangeocolinae (precise biology of *Hydrangeocola* is still unknown) are specialist parasitoids of gall-forming Diptera while the closely related Mesostoinae are cecidogenic suggests that the latter biology could have evolved from the former, as has been suggested for cecidogenic Eurytomidae (Chalcidoidea). It would be interesting to know whether any hydrangeocolines have also made this transition.

We wish to emphasise that we have not yet obtained any strong evidence about whether *Aspilodemon* is ecto- or endoparasitic. Although no host remains were found in galls parasitised by this wasp, indicating that all the host cuticle had been consumed, it should be noted that most endoparasitic braconids (those belonging to the 'helconoid' and 'microgastroid' groups of subfamilies—see Belshaw et al. 2000), very often emerge from their hosts before pupation and have an external feeding phase (Shaw and Huddleston 1991, Shaw and Quicke 2000). So even if the sternal spatula has been consumed it does not necessarily mean that the parasitoid was not endoparasitic in its earlier instars.

*Aspilodemon* differs from *Hydrangeocola* in only one fixed character—the fore wing pterostigma is narrow but distinct from vein R1 in the latter, whereas there is no discernible pterostigma in the former. In addition, *Aspilodemon* always lacks fore

wing vein 2a, whereas it is present in most *Hydrangeocola*. Given that for both these characters, *Hydrangeocola* displays (at least most species) the putatively plesiomorphic state, it is likely that the species classified under *Aspilodemon* may simply be a derived group of species within a broader concept of *Hydrangeocola*.

## ACKNOWLEDGEMENTS

We would like to acknowledge Ricardo F. Monteiro (UFRJ) for helping during all phases of the work, Raymond Gagné for identifying and describing the Cecidomyiidae species, IBAMA and IEF/SP for authorization to collect in the Units of Conservation, CNPq for the scholarships to R.A.M. Oda and financial support.

## LITERATURE CITED

- Austin, A. D. and D. C. Dangerfield. 1998. Biology of *Mesostoa kerri* Austin and Wharton (Insecta: Hymenoptera: Braconidae: Mesostoinae), an endemic Australian wasp that causes stem galls on *Banksia marginata* Cav. *Australian Journal of Botany* 46: 559–569.
- Belshaw, R., M. Dowton, D. L. J. Quicke, and A. D. Austin. 2000. A Gondwanan origin for a group of principally north temperate aphid parasitoids. *Proceedings of the Royal Society, London B*. 267: 491–496. [and electronic appendix at <http://www.pubs.royalsoc.ac.uk/publish/pro-bs/rpbl442.htm>]
- Belshaw, R., E. Herniou, C. Gimeno, M. G. Fitton and D. L. J. Quicke. 1998. Molecular phylogeny of the Ichneumonoidea (Hymenoptera) based on D2 expansion region of 28S rDNA. *Systematic Entomology* 23: 109–123.
- Belshaw, R. and D. L. J. Quicke. In press. Assessing character transitions when estimates of phylogeny are uncertain: the evolution of koinobiosis on concealed hosts by ichneumonoid parasitoids. *Systematic Biology*.
- Brêthes, J. 1927. Nouveaux Hyménoptères parasites du Chili. *Revista Chilena de Historia Natural* 31: 194–200.
- Dowton, M., R. Belshaw, A. D. Austin and D. L. J. Quicke. In press. Simultaneous molecular and morphological analysis of braconid relationships (Insecta: Hymenoptera: Braconidae) indicates independent mt-tRNA gene inversions within a single wasp family. *Journal of Molecular Evolution*.
- Fischer, M. 1966. *Aspilodemon* ein neues Opiinen-Genus aus Brasilien (Hymenoptera, Braconidae). *Entomophaga* 11: 161–176.
- Fischer, M. 1968. *Kephalosema* ein neues Horniinen-

- Ceratosolenites* (Hymenoptera: Braconidae). *Problemy Zoologii Entomologiczne* 38: 791–805.
- Gagliardi, F. J., R. A. M. Oda and R. F. Monteiro. 2001. Fig-wasp midges (Diptera: Cecidomyiidae) of *Mikania glomerata* (Asteraceae) in southeastern Brazil. *Proceedings of the Entomological Society of Washington* 103: 110–134.
- Infante, F., P. Hanson and R. A. Wharton. 1995. Phytophagy in the genus *Monitoriella* (Hymenoptera: Braconidae) with description of new species. *Annals of the Entomological Society of America* 88: 406–415.
- King, R. M. and H. E. Robinson. 1987. *The genera of Eupatoriaceae (Asteraceae)*. Missouri Botanical Garden, St. Louis. 581pp.
- Macêdo, M. V. de and R. F. Monteiro. 1989. Seed predation by a braconid wasp, *Allorhogas* sp. (Hymenoptera). *Journal of the New York Entomological Society* 97: 358–362.
- Marsh, P. M., M. V. de Macedo and M. C. P. Pimental. 2000. Descriptions and biological notes on two new phytophagous species of the genus *Allorhogas* from Brazil (Hymenoptera: Braconidae: Doryctinae). *Journal of Hymenoptera Research* 9: 292–297.
- Mori, S. A., B. M. Boom and G. T. Prance. 1981. Distribution patterns and conservation of eastern Brazilian coastal forest species. *Brittonia* 33: 233–245.
- Quicke, D. L. J., C. van Achterberg and H. C. J. Godfray. 1997. Comparative morphology of the venom gland and reservoir in opiine and alysiine braconid wasps (Insecta, Hymenoptera, Braconidae). *Zoologica Scripta* 26: 23–50.
- Quicke, D. L. J. and R. Belshaw. 1999. Incongruence between morphological data sets: an example from the evolution of endoparasitism among parasitic wasps (Hymenoptera: Braconidae). *Systematic Biology* 48: 436–454.
- Quicke, D. L. J. and T. Huddleston. 1989. The Australian braconid wasp subfamily Mesostoinae (Hymenoptera: Braconidae) with the description of a new species of *Mesostoa*. *Journal of Natural History* 23: 1309–1317.
- Ramirez, W. B. and P. M. Marsh. 1996. A review of the genus *Psenobolus* (Hymenoptera: Braconidae) from Costa Rica, an inquiline fig wasp with brachypterous males, with description of two new species. *Journal of Hymenoptera Research* 5:64–72.
- Ritter, M. R., L. R. M. Baptista, and N. I. Matzenbacher. 1992. Asteraceae gênero *Mikania* Willd Seccões Globosae e Thirsigeriae. *Boletim do Instituto de Biociências / UFRGS* 50: 1–90.
- Sharkey, M. J. and R. A. Wharton. 1997. Morphology and terminology. In R. A. Wharton, P. M. Marsh & M. J. Sharkey (eds) *Identification manual to the New World genera of Braconidae*. Special Publication of the International Society of Hymenopterists 1: 19–37.
- Shaw, M. R. and T. Huddleston. 1991. Classification and biology of braconid wasps (Hymenoptera: Braconidae). *Handbooks for the Identification of British Insects* 7(11): 1–126..
- Shaw, M. R. and D. L. J. Quicke. 2000. The biology and early stages of *Acampsis alternipes* (Nees), with comments on the relationships of the Sigalphinae (Hymenoptera: Braconidae). *Journal of Natural History* 34: 611–628.
- Wharton, R. A. 1988. Classification of the braconid subfamily Opiinae (Hymenoptera). *The Canadian Entomologist* 120:333–360.
- Wharton, R. A. 1993. Review of the Hormiini (Hymenoptera: Braconidae) with a description of new taxa. *Journal of Natural History* 27: 107–171.
- Whitfield, J. B. and R. A. Wharton. 1997. Subfamily Hormiinae. In R. A. Wharton, P. M. Marsh and M. J. Sharkey (eds) *Identification manual to the New World genera of Braconidae*. Special Publication of the International Society of Hymenopterists 1: 285–301.

## First Record of *Aridelus rufotestaceus* Tobias (Hymenoptera: Braconidae, Euphorinae) Parasitizing *Nezara viridula* Nymphs (Heteroptera: Pentatomidae) with Observations on its Immature Stages and Development

SCOTT R. SHAW, GIANANDREA SALERNO, STEFANO COLAZZA, AND EZIO PERI

(SRS) Insect Museum, Department of Renewable Resources, University of Wyoming, Laramie, WY 82071-3354, USA; (GS) Department of Arboriculture and Plant Protection, University of Perugia, 06122 Perugia, Italy; (SC, EP) Institute of Agricultural Entomology, University of Palermo, Palermo, Italy

---

*Abstract.*—*Aridelus rufotestaceus* Tobias is recorded for the first time from Italy as parasitizing the pentatomid bug *Nezara viridula* L. This is the first record of the species in southern Europe and the first host data. The species is re-described and illustrated. New information is provided on its immature stages, development, and biological control potential.

---

Species of the euphorine braconid genus *Aridelus* Marshall are cosmopolitan in distribution, but most diversified in tropical areas (Shaw 1985). *Aridelus* species are quite distinctive in appearance, and can be easily distinguished from other braconids by their coarse honey-combed areolate mesosomal sculpture in combination with the long, tubular first metasomal segment and fore wing with a closed second submarginal cell (Shaw 1997). Their biology is not well known but the available records indicate that they are solitary koinobiont endoparasitoids of heteropteran bugs in the families Pentatomidae, Plataspididae, Scutelleridae, and Acanthosomatidae (Kirkpatrick 1937; Shenefelt 1969; Papp 1974; Čapek and Davidová-Vilimová 1978; Tobias 1986; Shaw 1988; Maetô and Kudô 1992).

Papp (1965) provided a taxonomic monograph of the world species of *Aridelus*, however, six Afrotropical species described by De Saeger (1946) were not included in Papp's monograph. Later, Papp (1974) erected the genus *Arideloides* for a species from New Guinea, but Shaw (1985) transferred the species to *Aridelus*.

He (1980) described a new species from China, Chou (1987) revised the species of Taiwan, and, most recently, Chen and van Achterberg (1997) revised the *Aridelus* species of China. They indicated that about 40 *Aridelus* species are now known, of which 20 are recorded from China. Shaw (1985) estimated that there are at least ten undescribed *Aridelus* species in the Neotropical region. Despite recent taxonomic work, until now only one species of *Aridelus* has been recorded from Europe (Shenefelt 1969; Papp 1974; Čapek and Davidová-Vilimová 1978).

The purpose of this paper is to provide new host and distribution records for *Aridelus rufotestaceus* Tobias recently discovered in Italy parasitizing the pentatomid bug *Nezara viridula* (L.). This is the first record of the species in southern Europe and the first host data. The host, *Nezara viridula*, is one of the most serious agricultural insect pests worldwide, damaging a wide variety of fruit, nut, grain, and vegetable crops. It is the primary pest of soybean in many parts of the world (Todd 1989) and it also attacks many wild hosts that serve as reservoirs until agricultural crops are

available (Jones and Sullivan 1988). In Italy, annual losses due to this pest fluctuate in relation to changes in population abundance of *N. viridula* (Zandigiaco 1990; Colazza and Bin 1990, 1995). Although this pest has been the focus of numerous biological control programs, most of the recorded biological control agents attack the egg stage. The only other parasitoids known to attack the nymphal and adult stages of *N. viridula* are Tachinidae and Encyrtidae. Until now no species of Braconidae has been discovered attacking this host (Jones 1988).

#### MATERIALS AND METHODS

Periodically, during summer and autumn 1998 and 1999, adults and nymphs of *N. viridula* were collected in the fields in Umbria, Lazio and Sicily regions following the seasonal sequence of host plant species. Most of the specimens were collected on maize and various vegetable plants. A study colony of the parasitoid was established and maintained in Italy by GS. Parasitoids were reared in the laboratory at a temperature of 24 plus or minus 1 degree C, relative humidity 65% plus or minus 5%, and light/dark conditions of 16 hours light and 8 hours darkness daily. The insects were kept in plastic boxes and fed with vegetables and sunflower seeds. Boxes were examined daily to collect parasitoid cocoons. Also, each day 5 *N. viridula* nymphs of the same age (reared in the laboratory) were exposed to a parasitoid female in a plastic box (7 × 5.5 × 2.5 cm) for 24 h. The parasitized nymphs were removed from the box and kept separately until appearance of parasitoid cocoons.

Some nymphs were dissected to observe the different developmental stages of the parasitoid. For SEM analysis the immature stages were fixed in Karnovsky's medium (Karnovsky 1965) for one hour at 4 °C, dehydrated in graded ethanol series, critical-point dried, mounted on stubs, coated with gold and observed with a Philips EM

515 scanning electron microscope. Adult specimens were preserved in 95% ethanol and sent to SRS for description. Preserved adult specimens were transferred to 100% ethanol for 24 hours, then into chloroform for 30 minutes prior to drying and point-mounting to prevent shrinkage.

#### *Aridelus rufotestaceus* Tobias, 1986

(Figs. 1–10)

*Description of adult female.*—length of body 4.8 mm; length of fore wing 3.5 mm. *Head:* Width of head in dorsal view 2.1 times its length; length of first flagellomere 1.5 times length of second flagellomere; length of first and penultimate flagellomeres 4.5 and 0.8 times their width, respectively; median frontal carina weakly developed and somewhat obscured by coarse punctate sculpturing; vertex sculpture densely punctate; ocellar-ocular distance 4.5 times ocellar diameter; occipital carina dorsally well-developed and complete; length of eye in dorsal view 1.6 times length of temple; face and clypeus sculpture densely and coarsely punctate; intertentorial line 1.6 times length of tentorial-ocular line; malar space 0.33 times height of eye. *Mesosoma:* 1.8 times longer than wide in dorsal view, densely areolate. *Wings:* Pterostigma 2.0 times longer than wide at midpoint, anterior margin distinctly rounded and protruding well beyond anterior margin of wing as delimited by vein C+SC+R; length of marginal cell 0.85 times pterostigma length; vein r nearly perpendicular to pterostigma and 2.5 times longer than vein 3RSa bordering second submarginal cell dorsally; vein 3RSb nearly straight basally then curving towards wing margin apically; vein m-cu slightly antefurcal relative to vein 2RS, with very short segment of vein (RS+M)b present. *Metasoma:* Entirely smooth and highly polished; length of first metasomal segment 7.0 times its width at spiracles; metasoma beyond petiole 2.7 times longer than wide in dorsal view; ovipositor sheath very short, exposed portion about

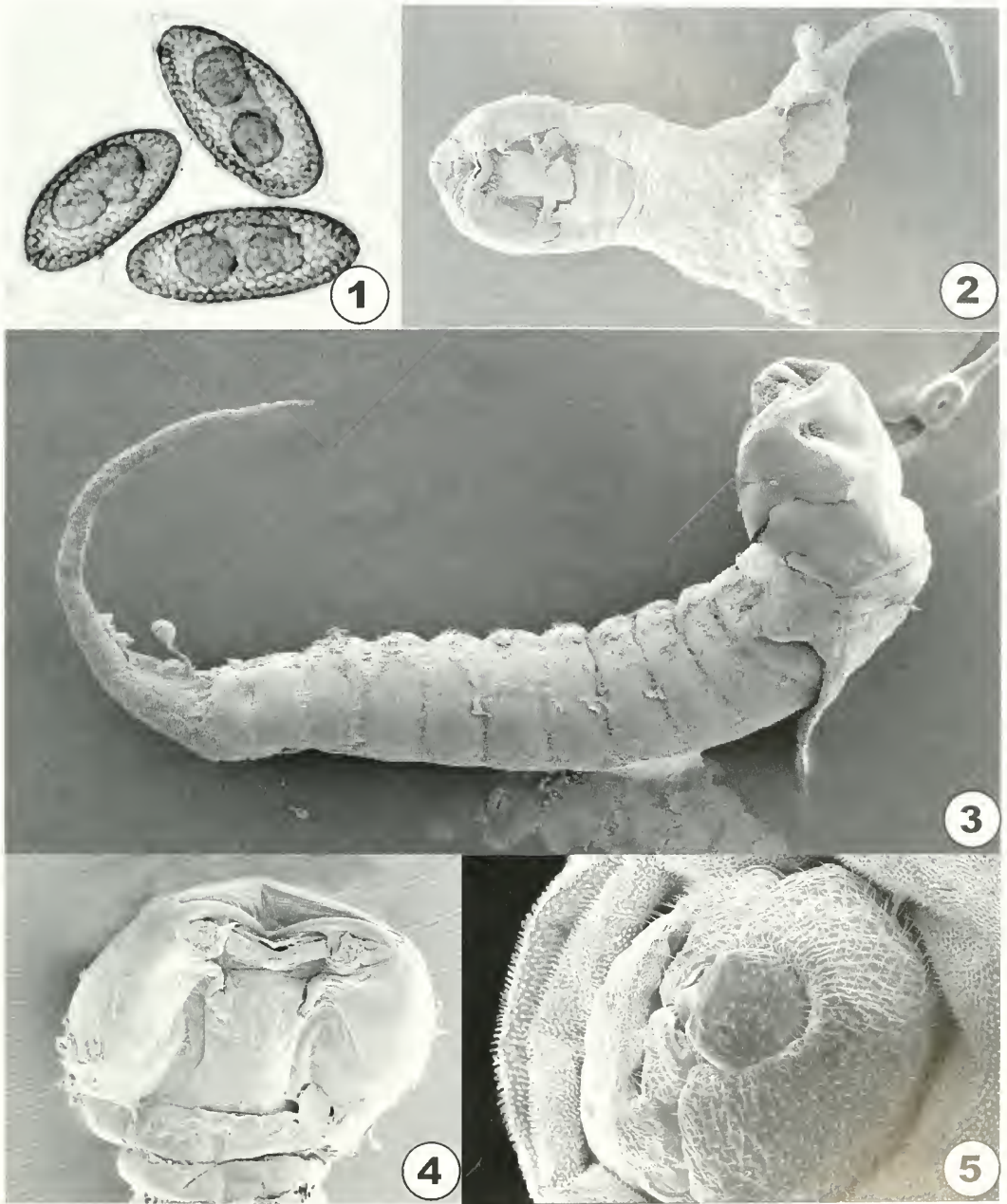

Figs. 1–5. *Aridelus rufotestaceus*. 1, Eggs with developing embryos, 200×. Figs. 2–4. First instar larva. 2, Larva still partially surrounded by trophamnion and teratocytes, ventral view, 70×. 3, Lateral view, 100×. 4, Ventral view of head capsule and mouthparts, 170×. 5, Third instar larva, antero-ventral view of head capsule and mouthparts, 105×.

0.5 times length of hind basitarsus. *Color*: Head, antenna basally, lateral borders of pronotum, legs, and metasoma orangish brown; mandible apically, ocellar triangle,

remainder of mesosoma, and ovipositor sheath black; wing venation brown, membrane clear to slightly dusky medially.

*Variation*.—Body position at death vary-

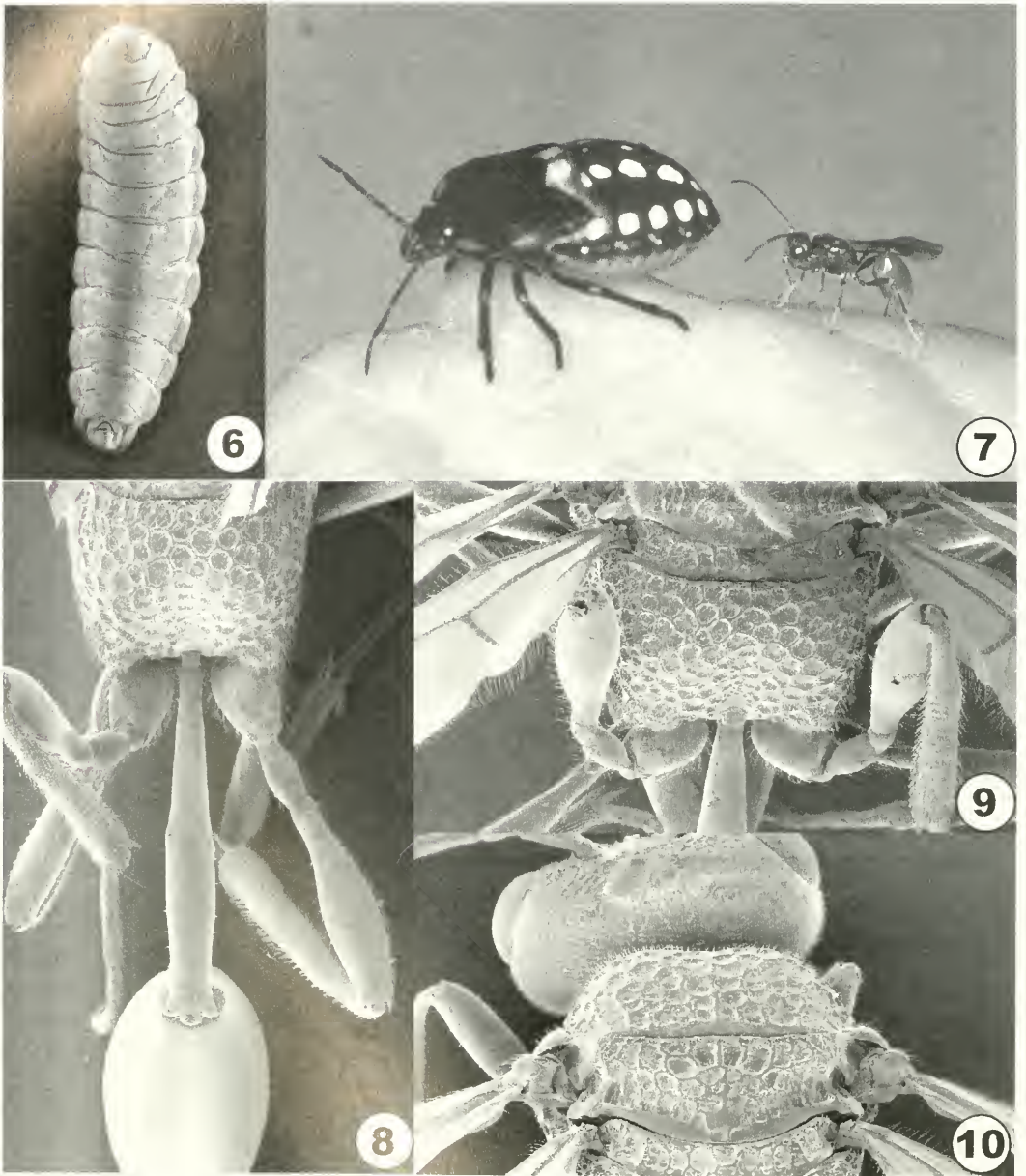

Figs. 6–10. *Aridelus rufotestaceus*. 6, Third instar larva, ventral view, 11 $\times$ . Figs. 7–10 Adult. 7, Female near *Nezara viridula* nymph. 8, Propodeum and metasoma, dorsal view, 42 $\times$ . 9, Propodeum, dorsal view, 38 $\times$ . 10, Head, mesoscutum, and scutellum, dorsal view, 42 $\times$ .

ing from metasoma fully extended posteriorly to fully extended anteriorly (ovipositional stance) with metasomal petiole bent under mesosoma and apex of metasoma extending well beyond face. Some individuals appear darker with the head

dorsally, hind femur, hind tibia, petiole, and dorsum of metasoma posteriorly more or less infused with smokey black pigmentation. In all cases dead preserved specimens appear somewhat to have a darker mesosoma; while alive some or-

angish brown color shows through the darker black pigmentation. Aside from genitalic differences, the male is quite similar in form and sculpture, but is much lighter in color appearing mostly orange, even over the mesosoma where black pigmentation is limited to smoky pigmentation along the borders of the areolation.

*Description of immature stages.*—The egg is alecithal (with no visible yolk), oval, with a clear chorion through which the white embryo and developing trophamnion are visible. The developing embryo has a large oval head capsule, followed by 12 similar undifferentiated body segments. The thoracic segments are not visibly different from the abdominal segments. The trophamnion forms a large mass of spongy white teratocytes below the embryo, enveloping the embryo posteriorly. The mature embryo has a thick round head capsule with no trace of eyes or antenna, deep anterior tentorial pits, long sickle-like mandibles, simple mouth opening, 11 undifferentiated similar body segments, and 12<sup>th</sup> segment longer bearing anus ventrally and a long tapering caudal appendage. The first instar larva is of the caudate form, similar to the mature embryo with a thick round head capsule with no trace of eyes or antenna, deep anterior tentorial pits, long sickle-like mandibles, simple mouth opening, 11 undifferentiated similar body segments, and 12<sup>th</sup> segment longer bearing anus ventrally and a long tapering caudal appendage densely covered with short, thick, flexible setae. The first instar has an apneustic respiratory system, with no visible spiracles. The body becomes much thicker as the young larva feeds and grows. The second instar larva becomes hymenopteriform remains apneustic. The sclerotized head capsule is much smaller, with short mandibles, and becomes enveloped by the fleshy first thoracic segment as the larva grows. The second instar larva is yellowish white with undifferentiated segments, less distinct than in the first instar, and about 5x longer

than wide. The caudal appendage is lost. The third and final instar larva is also hymenopteriform and apneustic, but thicker and more maggot-like. It is tapering at both ends and thickest medially, being about 3x longer than wide at maturity.

*Biology.*—*Aridelus rufotestaceus* was found for the first time in October 1998 near the Umbria region of Perugia, Italy (parasitism rate 4.3%). During the summer of 1999 we found the parasitoid in the Lazio region (parasitism rate 21.7%) and in Sicily (parasitism rate 12.5%). The mature egg is usually lemon-shaped, with a pedicel. When the first instar larva hatches from the egg, the teratocytes dissociate into the hemolymph and increase in size. In laboratory conditions the period from egg deposition to emergence of the mature larva was 23.18 plus or minus 2.77 days ( $n = 37$ ). The mature larva emerges from the host through a hole in the intersegmental membrane between the ultimate and penultimate segments, crawls away, and spins an oval white silk cocoon. After emergence of the parasitoid larva the host may survive for several days (although clearly not in healthy condition). Adults emerged from the cocoon in 22.27 plus or minus 1.45 days ( $n = 37$ ). The adult life span was, in mean, 212.08 plus or minus 8.18 days ( $n = 106$ ) with a range from 6 to 43 days. Reproduction is parthenogenetic (thelytokous, or sometimes deuterotokous). In the lab only 3 males were obtained relative to 200 females. Prior to oviposition females approach potential hosts on foot and inspect them, both visually and via antennation. Oviposition is typically very rapid, lasting a few seconds at most, during which the female rapidly approaches the host on foot, throws back the antennae, flexes the metasoma under the mesosoma while both exerting the ovipositor and telescoping posterior metasomal segments. Eggs are inserted into the membranous cervical region between the head and thorax or into the intersegmental areas of the posterior abdominal region of

the host. Supernumerary eggs of larvae were dissected from hosts collected in the field and in hosts parasitized in the laboratory, but in all cases only one larva developed per host. In the laboratory *Aridelus rufotestaceus* was able to parasitize 2<sup>nd</sup>, 3<sup>rd</sup>, and 4<sup>th</sup> instar host nymphs, as well as adults. Younger instars were more suitable for parasitoid development with 95% of 3<sup>rd</sup> instars parasitized and 85.7% of 2<sup>nd</sup> instars parasitized permitting complete parasitoid development. The highest mortality rate recorded for parasitized adults was 80.0%.

*Discussion.*—Terminology used in the description follows that of Sharkey and Wharton (1997). This species is a typical member of the genus and can be keyed to genus without difficulty using the key provided by Shaw (1997). This species can be identified using the key to Chinese *Aridelus* species provided by Chen and van Achterberg (1997). In the key to world species of Papp (1965) this species keys to couplet 23, *A. nigrithorax* Muesebeck, but *A. rufotestaceus* can be distinguished from that species by its lighter colored antenna (flagellum entirely black in *A. nigrithorax*), more coarsely sculptured head (head only finely punctate in *A. nigrithorax*), and weakly developed median frontal carina (strongly developed in *A. nigrithorax*). *A. rufotestaceus* can be distinguished from *A. egregius* Schmiedeknecht, the only other European species, by its more coarsely sculptured head and lighter body (head mostly smooth and body black in *A. egregius*). The three described North America species, *A. fisheri* (Viereck), *A. melanderi* (Brues), and *A. nigrithorax* Muesebeck, are identical morphologically but differ only in color (entirely orange, black head, or black mesosoma, respectively). Given the wide range of color variations seen in *A. rufotestaceus*, it would seem questionable to separate *Aridelus* species based on color alone. Careful field studies are needed for the North American species to examine if

the observed color forms are related to patterns of host use.

The study of Čapek and Davidová-Vilimová (1978) suggested that there are four larval instars in *A. egregius*, but our observations suggest only three larval instars in *A. rufotestaceus*. Čapek and Davidová-Vilimová defined their instars 1 and 2 as morphologically similar, but differing only in slight differences in the length of the mandible. In fact, since their first instar was arbitrarily defined as comprising the smallest individuals, and was based only on 2 individuals (N = 2), their sample size was simply too small to demonstrate a statistically significant difference between their instars 1 and 2. Another possible explanation is that all their individuals with long, fighter-type mandibles and caudal appendage belong to the same instar (1) and there are only 3 instars.

It is worth stressing that in Italy no braconid has ever been recorded as parasitoid of Pentatomidae. Moreover, since 1989, the Department of Arboriculture and Plant Protection of the University of Perugia periodically collected *N. viridula* from the field to assess the parasitization level of tachinid flies, and the presence of any braconid was never observed. In consideration of this, we can hypothesize a recent fortuitous introduction of *A. nezara-phagus* in Italy, as happened in the past for the tachinid *Trichopoda pennipes* F. (Colazza *et al.* 1996). Since the parasitoid was already recorded from China and Russia, this may be a natural range extension from eastern areas. Another possibility is that the parasitoid may have previously been present but made a recent host-switch from other hosts. However, no alternate hosts have yet been found in Italy, although the following pentatomids have been examined for the presence of the parasitoid: *Eurydema oleraceum* (L.), *Eurydema ventrale* (Klt.), *Eurygaster* sp., *Graphosoma lineatum* (L.) and *G. semipunctatum* (F.).

*Material examined for re-description of adult.*—3 females: Italy, Palermo, lab

reared ex. *Nezara viridula*, December 1999; 5 females, 1 male, same data except Perugia, October 1998; 21 females, same data except Perugia, August 1999. Specimens deposited in University of Wyoming Insect Museum, Laramie; Nationaal Natuurhistorisch Museum, Leiden, The Netherlands; and Natural History Museum, Budapest, Hungary.

#### ACKNOWLEDGMENTS

We are very grateful to Prof. Ferdinando Bin, Department of Arboriculture and Plant Protection, University of Perugia, Italy for his helpful cooperation. We also wish to thank Dr. C. van Achterberg of the Nationaal Natuurhistorisch Museum, Leiden, The Netherlands, for his helpful cooperation in borrowing the holotype of *A. rufotestaceus* and confirming the identity of this species.

#### LITERATURE CITED

- Čapek, M. and J. Davidová-Vilimová. 1978. On the life history of *Aridelus egregius* (Hymenoptera, Braconidae) a parasite of European *Coptosoma* (Heteroptera, Plataspidae). *Acta Entomologica Bohemoslovaca* 75(4): 243–254.
- Chen, X. and C. van Achterberg. 1997. Revision of the subfamily Euphorinae (excluding the tribe Meteorini Cresson) (Hymenoptera: Braconidae) from China. *Zoologische Verhandlungen* 313: 1–217.
- Chou, L. Y. 1987. The genus *Aridelus* of Taiwan (Hymenoptera: Braconidae). *Taiwan Agricultural Research Institute at Taipei Special Publication* 22: 19–39.
- Colazza, S. and F. Bin. 1990. Pentatomidi ed i loro entomofagi associati alla soia in Italia centrale. *Informatore fitopatologico* 2: 38–42.
- Colazza, S. and F. Bin. 1995. Efficiency of *Trissolcus basalus* (Hymenoptera: Scelionidae) as an egg parasitoid of *Nezara viridula* (Heteroptera: Pentatomidae) in Central Italy. *Environmental Entomology* 26 (6): 1703–1707.
- Colazza, S., G. Giangiuliani, and F. Bin. 1996. Fortuitous introduction and successful establishment of *Trichopoda pennipes* F.: adult parasitoid of *Nezara viridula* (L.). *Biological Control* 6: 409–411.
- De Saeger, H. 1946. Euphorinae (Hymenoptera: Apocrita). *Exploration du Parc National Albert Mission G. F. De Witte (1933–1935)*, Fascicule 50: 1–245.
- He, J. H. 1980. Description of a new species of *Aridelus* Marshall from Jilin Province, China (Hymenoptera: Braconidae). *Journal of the Zhejiang Agricultural University* 6: 85–87.
- Jones, W. A. 1988. World review of parasitoids of the southern green stink bug, *Nezara viridula* (L.) (Heteroptera: Pentatomidae). *Annals of the Entomological Society of America* 81(2): 262–273.
- Jones, W. A. and M. J. Sullivan. 1982. Role of host plants in population dynamics of stink bug pests of soybean in South Carolina. *Environmental Entomology* 11: 867–875.
- Karnovsky, M. S. 1965. A formaldehyde glutaraldehyde fixative of high osmolarity for use in electron microscopy. *Journal of Cell Biology* 27: 137–138.
- Kirkpatrick, T. W. 1937. Studies on the ecology of coffee plantations in East Africa. *The Transactions of the Royal Entomological Society of London* 86(14): 247–343.
- Maetô, K. and S. Kudô. 1992. A new euphorine species of *Aridelus* (Hymenoptera: Braconidae) associated with a subsocial bug *Elasmucha putoui* (Heteroptera, Acanthosomatidae). *Japanese Journal of Entomology* 60(1): 77–84.
- Papp, J. 1965. A monograph of the genus *Aridelus* Marsh. (Hymenoptera, Braconidae: Euphorinae). *Acta Zoologica Academiae Scientiarum Hungaricae* 11: 181–201.
- Papp, J. 1974. *Arideloides niger* gen. and sp. n. from New Guinea (Hymenoptera, Braconidae: Euphorinae). *Proceedings of the Hawaiian Entomological Society* 21: 443–446.
- Sharkey, M. J. and R. A. Wharton. 1997. Morphology and terminology. Pp. 19–37. In: Wharton, R. A., P. M. Marsh, and M. J. Sharkey (eds.), *Manual of the New World genera of the family Braconidae (Hymenoptera)*, Special Publication of the International Society of Hymenopterists, Number 1.
- Shaw, S. R. 1985. A phylogenetic study of the subfamilies Meteorinae and Euphorinae (Hymenoptera: Braconidae). *Entomography* 3: 277–370.
- Shaw, S. R. 1988. Euphorine phylogeny: the evolution of diversity in host-utilization by parasitoid wasps (Hymenoptera: Braconidae). *Ecological Entomology* 13(3): 323–335.
- Shaw, S. R. 1997. Subfamily Euphorinae. Pp. 234–254. In: Wharton, R. A., P. M. Marsh, and M. J. Sharkey (eds.), *Manual of the New World genera of the family Braconidae (Hymenoptera)*, Special Publication of the International Society of Hymenopterists, Number 1.
- Shenefelt, R. D. 1969. *Hymenopterorum Catalogus, Braconidae 1, Euphorinae*. 176 pp. W. Junk, The Hague.
- Tobias, V. I. 1986. 8. Subfamily Euphorinae. In: Medvedev, G. S. (ed.), *Identification key for insects of the European part of the U.S.S.R. Vol. III. Hymenoptera*. 4: 181–250. Nauka Publishing House, Leningrad. (in Russian)
- Todd, T. W. 1989. Ecology and behavior of *Nezara viridula*. *Annual Review of Entomology* 34: 273–292.
- Zandigiacoimo, P. 1990. The principal pests of soybean in northeastern Italy in 1989. *Informatore fitopatologico* 40(8): 55–58.

## A New Species of *Streblocera* (*Asiastreblocera*) (Braconidae: Euphorinae) from Thailand with Depressed Ovipositor

DONALD L. J. QUICKE AND ANDY PURVIS

(DLJQ) Unit of Parasitoid Systematics, Department of Biology, Imperial College at Silwood Park, Ascot, Berkshire SL5 7PY, UK, and Department of Entomology, The Natural History Museum, London SW7 5BD, UK; (AP) Department of Biology, Imperial College at Silwood Park, Ascot, Berkshire SL5 7PY, UK

---

*Abstract.*—A new species of euphorine braconid, *Streblocera* (*Asiastreblocera*) *olivera* Quicke and Purvis, new species, from Thailand is described and illustrated. This is the first record of the genus from SE Asia. The description uses SEM to illustrate several features, including the ovipositor and facial horn for the first time. *S. (A.) olivera* is distinguished from the other four described members of the subgenus.

---

Euphorine braconids are interesting because they attack adults of holometabolous insects and adults and nymphs of hemimetabolous ones. Probably related to this, the adults show a remarkable range of forms which are often believed to be associated with host manipulation, including remarkably derived antennae and ovipositors (Shaw 1988).

*Streblocera* Westwood is a diverse genus of principally tropical species that is currently divided into a number of subgenera, largely on the basis of the form of the antenna. The hosts of *Streblocera* species appear to be chrysomelid beetle adults (Maetô and Nagai 1985, Shaw 1985), though host records are unavailable for most species. The subgenus *S. (Asiastreblocera)* Belokobylskij was described on the basis of a single species from China (*S. cornuta* Chao 1964) (Belokobylskij 1987) and since then three additional species have been described, and collectively the known subgeneric range has been found to include from Taiwan and Korea (Wang 1983, Chou 1990, Ku 1997, Belokobylskij and Ku 1998). *Asiastreblocera* differs from all other *Streblocera* in having a facial horn, the antenna geniculate at the 1<sup>st</sup> flagellar

segment which is not serrate but produced into a large ventral, flattened lobe, and in having a very short ovipositor that is not exerted. Recently we were able to study a series of a new species of *Streblocera* (*Asiastreblocera*) from Thailand collected by Dr Doug Yanega (University of California, Riverside), and this has given us the opportunity to obtain DNA sequence data for the subgenus, and to study the morphology of its modified antenna and ovipositor in more detail using scanning electron microscopy. Its D2-D3 28S rDNA sequence has been deposited in the EMBL database (accession number AJ302831) and will be incorporated into a forthcoming molecular phylogenetic study of the non-cyclostome braconids (Belshaw and Quicke, in press) and a combined molecular and morphological phylogeny of the Euphorinae (Quicke, Shaw and van Achterberg in preparation). We are describing this species here so as to make its name available for future publications.

### TERMINOLOGY AND COLLECTIONS

Body morphology terminology follows Achterberg (1979, 1988); wing venation terms used follow Sharkey and Wharton

(1997). Collections are abbreviated as follows: The Natural History Museum, London (BMNH); University of California, Riverside (UCR).

*Streblocera (Asiastreblocera)*  
**Belokobylskij**

Type species: *Streblocera cornuta* Chao 1964.

*Diagnosis.*—The only euphorine subgenus that has either a facial horn or a single or paired ventral projection from the 5<sup>th</sup> metasomal sternite. See Chen and van Achterberg (1997) for additional features of the subgenus.

*Distribution.*—China, Korea, Taiwan, Thailand and Vietnam.

*Streblocera (Asiastreblocera) olivera*  
**Quicke and Purvis, new species**  
(Figs. 1–16)

*Holotype female.*—THAILAND: 2 km south of Ban Pha Bong (a small town south of Mae Hong Son), riparian forest, low elevation, 1.vi.2000, coll. D. Yanega (BMNH). Paratypes. 2 females, both with same data as holotype (one coated in platinum and used for scanning electron microscopy BMNH, the other deposited in UCR).

*Diagnosis.*—This species may be distinguished from all other *Streblocera* species by the possession of a single, non-furcate, medio-posterior projection from the 5<sup>th</sup> metasomal sternite.

*Description.*—Female. Body length 2.6 mm and of forewing 2.8 mm. Antenna geniculate, 18-segmented, the terminal flagellomere partially divided on one side; scapus 1.56× longer than 1<sup>st</sup> flagellar segment which is strongly produced ventrally into lobe; pedicellus with notch ventrally containing discrete row of short, erect sensilla (Fig. 7). Scapus with 6–9 diagonal ridges medially (Figs. 2, 6); 1<sup>st</sup> flagellar segment with three diagonal ridges on the medio-ventral surface of the protruding lobe (Fig. 5). *Head:* 1.8× wider than medially long (excluding facial horn);

1.8× width of mesoscutum; largely smooth. Clypeus distinctly protruding from plane of face. Face densely setose (Figs. 2, 3). Face as wide as eye height; facial horn large, up-curved, apically blunt (transverse) in dorsal profile, without mid-longitudinal ridge (Figs. 1–3). Cheek height 0.26× height of eye, 1.0× basal width of mandible in frontal aspect. Distance between anterior tentorial pits: shortest distance from anterior tentorial pit to eye = 2.45:1.0. Width of head 2.35× width of face. Temple strongly narrowed behind eyes (Fig. 1). Transverse diameter of eye 4.0× length of temple (dorsal view). Eye 1.8× taller than wide in lateral aspect. Frons rather flat, medially glabrous, with slight pitting behind antennal sockets (Fig. 1). Transverse diameter of posterior ocellus: distance between posterior ocelli: shortest distance between posterior ocellus and eye = 1:2:3. Occipital carina absent medio-dorsally. *Mesosoma:* 1.7× longer (including neck-like pronotum) than maximally high. Pronope well-developed (Fig. 4). Mesoscutum smooth and shiny, virtually glabrous except along notauli which are weakly crenulate anteriorly. Notauli deep, largely smooth except for a few weak crenulae anteriorly; meeting medio-posteriorly in front of scutellar sulcus in a weakly depressed area with a few striae but no distinct midlongitudinal carina (Fig. 4). Scutellar sulcus long, with a single median carina (Fig. 4). Scutellum rather convex; medioposteriorly with a pair of pits (Fig. 10). Propodeum with median carina, on anterior 0.6 and with two pairs of strong transverse carinae; postero-medially with several short transverse carinae (Fig. 10). *Fore wing:* Vein 1-SR+M absent. Vein SR1 reaching wing margin 0.52 of distance from apex of pterostigma to the wing tip. Vein SR1 1.9× longer than m-cu. Vein 2-CU1 4× longer than 1-CU1. Vein r arising 0.63 distance from base of pterostigma. Pterostigma 3.0–3.1× longer than wide. *Hind wing:* Lengths of veins 1-M:1r-m:M+CU = 3.0:4.0:1.0. *Legs:* Length

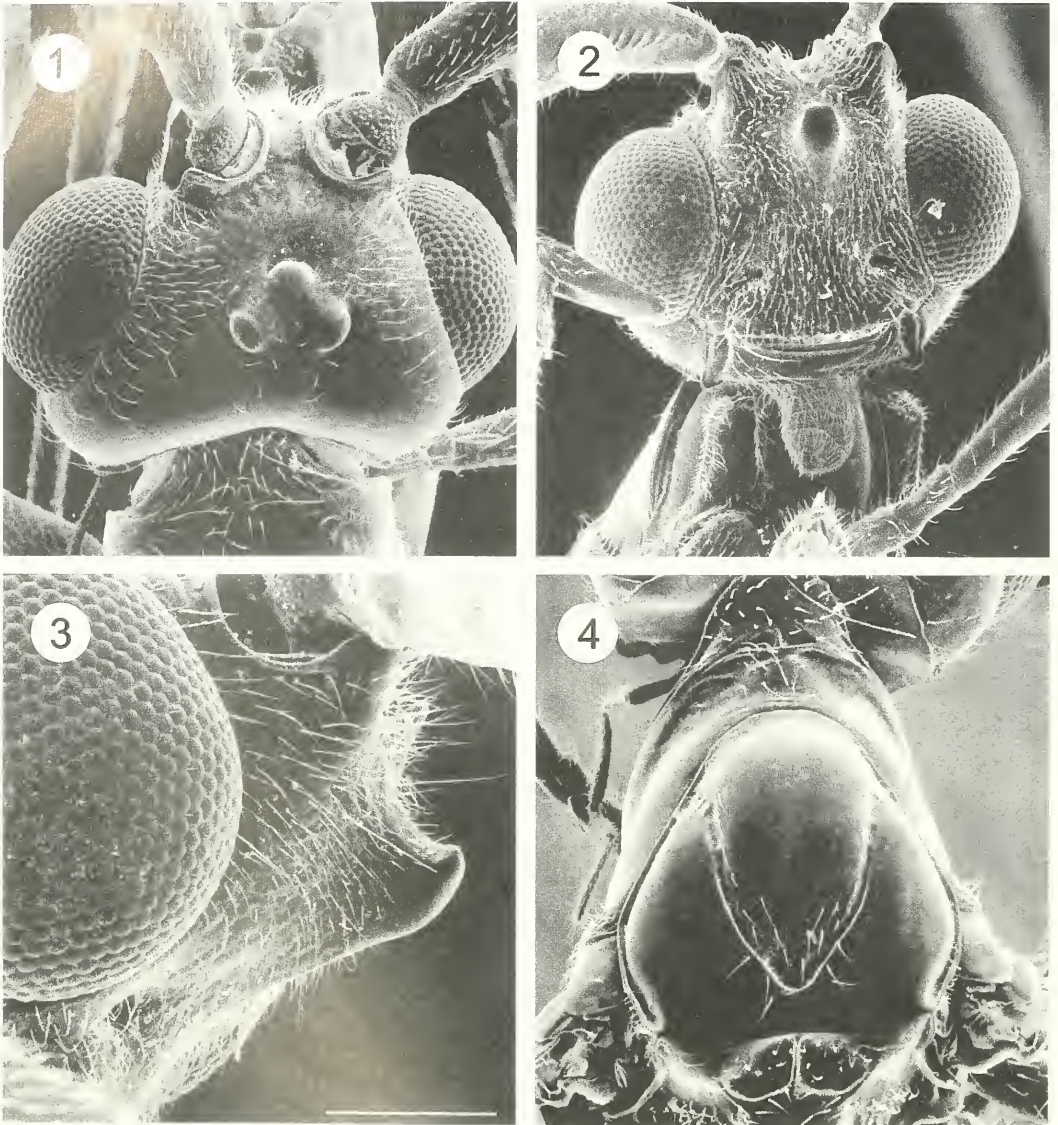

Figs. 1–4. *Streblocera (Asiastreblocera) olivera* sp. n., female paratype, scanning electron micrographs. 1, Head, dorsal view. 2, Head, facial view showing also, medioventral aspect of scapus with ridges, and an attached insect larva below mandibles. 3, Head, lateral aspect of facial horn. 4, Pronotum and mesoscutum, dorsal aspect. Scale bar (see Fig. 3): 1, 4 = 270  $\mu\text{m}$ ; 2 = 430  $\mu\text{m}$ ; 3 = 500  $\mu\text{m}$ .

of fore femur: tibia: basitarsus = 2.0:2.35:1.0. Hind femur: tibia: basitarsus = 2.2:3.0:1.0. Hind tibial spurs almost equal in length, each 0.25 $\times$  length of hind basitarsus. *Metasoma*: First tergite with fine longitudinal striation postero-laterally (Fig. 11); remaining tergites completely smooth; suture between 2nd and 3rd ter-

gites almost indistinguishable. 1st tergite 1.65 $\times$  longer than maximally wide; maximum width 3.1 $\times$  minimum width; distance from spiracles to posterior margin of tergite 1.25 $\times$  distance between spiracles; dorsopes very deep, separated from each other by an internal septum, visible through cuticle. 2nd tergite with a single

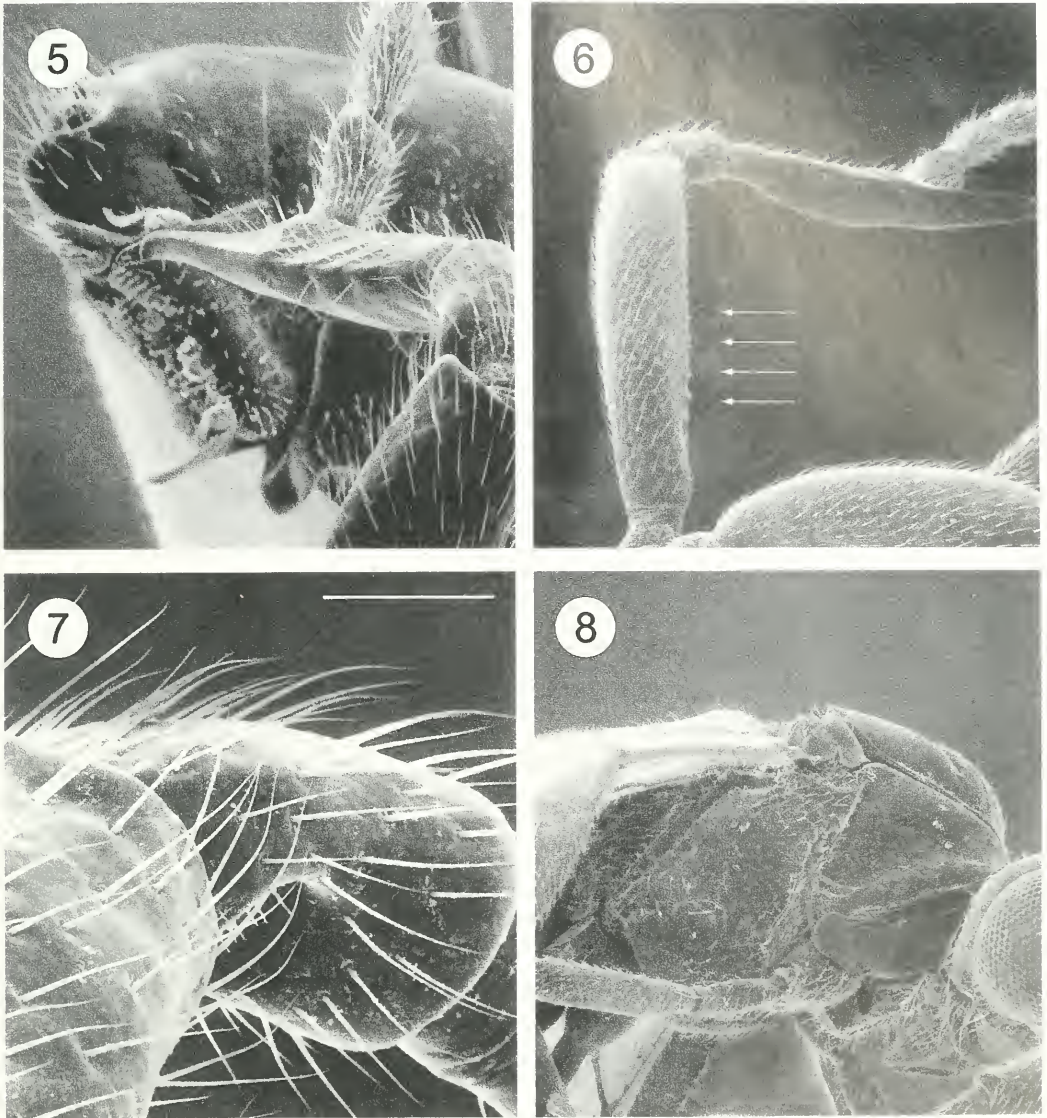

Figs. 5–8. *Streblocera (Asiastreblocera) olivera* sp. n., female paratype, scanning electron micrographs. 5, 1<sup>st</sup> flagellar segment showing 3 ridges on dorso-medial surface. 6, Scapus, pedicellus and base of flagellum, arrows indicating ridges. 7, Detail of pedicellus, ventro-lateral aspect showing transverse basal groove with row of short sensilla. 8, Anterior mesosoma, lateral aspect. Scale bar (see Fig. 7): 5 = 150  $\mu\text{m}$ ; 6 = 270  $\mu\text{m}$ ; 7 = 30  $\mu\text{m}$ ; 8 = 380  $\mu\text{m}$ .

transverse row of seta subposteriorly (Fig. 12). Tergites 4 and 5 with distinct medio-posterior protuberance (Fig. 12). Sternum 8 of metasoma with a single, medioposterior, apically rounded projection. Ovipositor very short, not extending beyond the apex of the hypopygium; markedly

dorso-ventrally depressed, apically transverse in dorsal profile (Figs. 15, 16). Area between hypopygium and terminal tergites setose (Fig. 16). *Colour*: Body pale brownish yellow, the propodeum medioposteriorly and the anterolateral parts of the 1<sup>st</sup> metasomal tergite, somewhat dark-

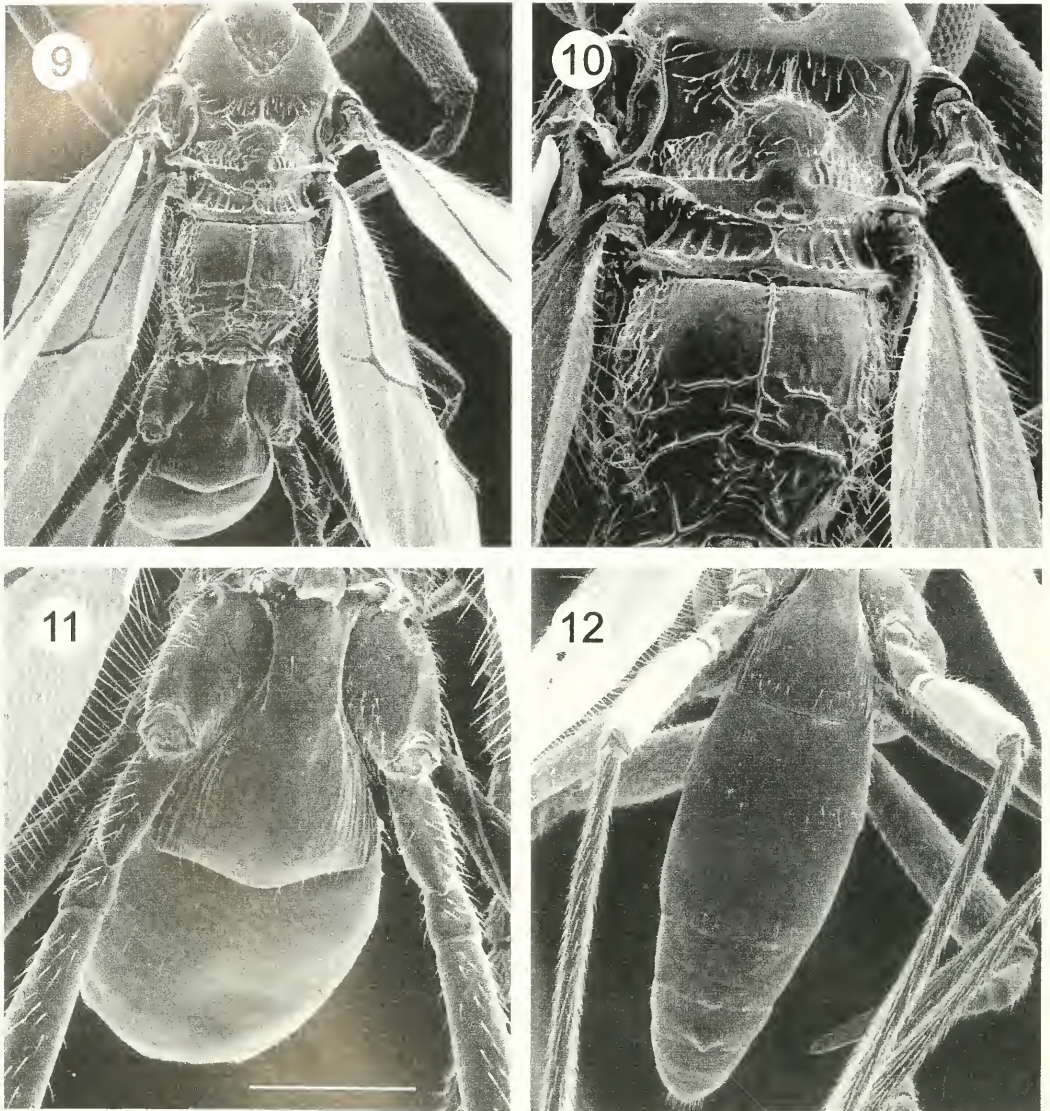

Figs. 9–12. *Streblocera (Asiastreblocera) olivera* sp. n., female paratype, scanning electron micrographs. 9, Mesosoma, wings and 1<sup>st</sup> metasomal tergite, dorsal aspect. 10, Scutellum, metanotum and propodeum detail. 11, 1<sup>st</sup> metasomal tergite showing fine lateral striations. 12, Metasoma, showing small medio-posterior protuberances of tergites 4 and 5. Scale bar (see Fig. 11): 9, 11 = 200  $\mu\text{m}$ ; 10, 12 = 100  $\mu\text{m}$ .

er, the legs and face whitish. Antenna brown.

*Male*.—Unknown.

*Etymology*.—Named after Oliver Purvis.

#### DISCUSSION

Most euphorines have moderately to highly modified ovipositors that are associated with oviposition into adult in-

sects, and their hosts often have highly sclerotized exoskeletons. Thus euphorine ovipositors mostly appear adapted to penetrating intersegmental membranes or similar vulnerable places on the host, and the typical adaptation is moderate to strong lateral compression (see Achterberg and Quicke 2000). A few euphorines have solved the problem differently, for

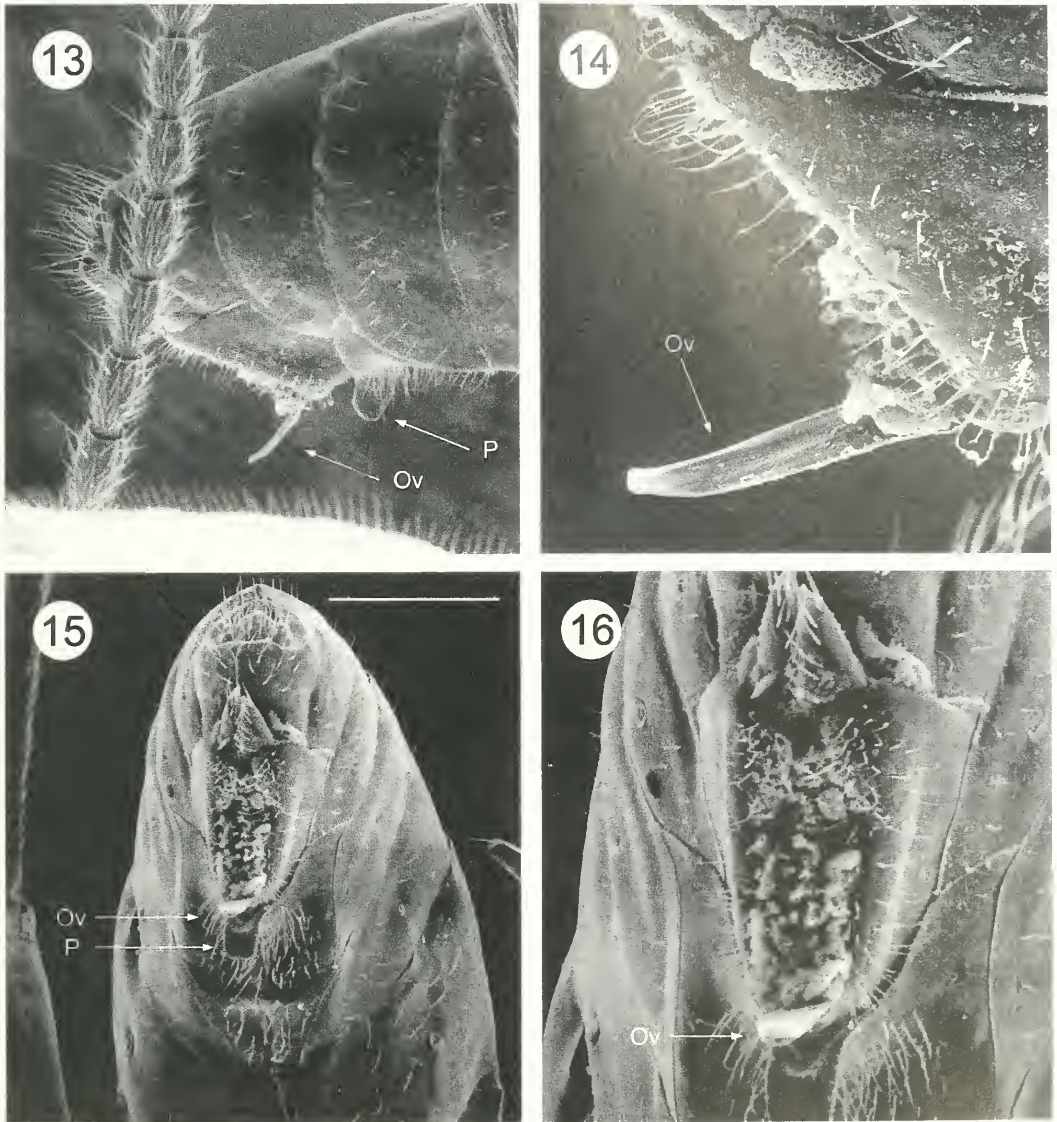

Figs. 13–16. *Streblocera (Asiastreblocera) olivera* sp. n., female paratype, scanning electron micrographs. 13, Apex of metasoma, lateral aspect, showing ovipositor (Ov) and protuberance (P) from 5<sup>th</sup> metasomal sternite. 14, Detail of ovipositor from dorso-lateral aspect. 15, Postero-ventral view of apex of metasoma showing ovipositor (Ov), protuberance (P), and 'secretion' covered seta between ovipositor and ovipositor sheaths. 16, Detail of apex of ovipositor showing its dorso-ventral compression. Scale bar (see Fig. 15): 13, 16 = 250  $\mu$ m; 14 = 300  $\mu$ m; 15 = 136  $\mu$ m.

example, species of *Spathicopsis* van Achterberg have a dorso-ventrally depressed and apically spatulate ovipositor, though unfortunately, their hosts are unknown (Chen and van Achterberg 1997). The dorso-ventral compression in some *Asiastreblocera*, including the new species, is inter-

esting because it shows that it is possible to evolve from lateral compression (as in *S. (A.) cornuta* Chao (*vide* Chen and van Achterberg 1997: Fig. 49)—perhaps through an almost cylindrical intermediate whose mode of function we can not guess at.

Although there has been speculation that the modified antennae in *Streblocera* may be involved in holding their beetle hosts, there have been no actual observations of this. The presence of diagonal striations on both the scapus and the ventral surface of the 1<sup>st</sup> flagellar segment is not unique to the new species described here (Xuexin X. Chen, personal communication) though their function is not known. They may be involved in host-restraint/manipulation, but it is also possible that they might act as stridules for sound production.

The setae in the anal area of all specimens examined are covered with an apparently congealed substance (Figs. 15, 16). If this material is a secretory product, it may be involved in some marking function. Unfortunately, such congealed materials are often ignored by taxonomists making it difficult to assess both their taxonomic distribution and how consistent they are within a taxon. In addition, *S. (A.) olivera* has the 4<sup>th</sup> and 5<sup>th</sup> metasomal sternites particularly densely setose, but these setae are not covered in secretion and their function is unknown though they could be sensory.

#### ACKNOWLEDGEMENTS

We are indebted to Doug Yanega (Entomology Research Museum, University of California, Riverside) for collecting this interesting species and making material available for study, to Xuexin X. Chen for information about work on *Asiastreblocera* in China and Korea, to Nicola Simpson for making the SEMs and to David Orme for mounting the plates. The specimens were exported under licence (No. 0741/481) issued by the Bangkok CITES office of the Royal Forest Department.

#### LITERATURE CITED

- Achterberg, C. van. 1979. A revision of the subfamily Zelinae auct. (Hymenoptera, Braconidae). *Tijdschrift voor Entomologie* 122: 241-479.
- Achterberg, C. van. 1988. Revision of the subfamily Blacinae Foerster (Hymenoptera, Braconidae). *Zoologische Verhandlungen, Leiden* 249: 1-324.
- Achterberg, C. van and D. L. J. Quicke. 2000. The palaeotropical species of the tribe Cosmophorini Capek (Hymenoptera: Braconidae: Euphorinae) with descriptions of twenty-two new species. *Zoologische Mededelingen, Leiden* 74: 283-338.
- Belokobylskij, S. A. 1987. To the knowledge of the braconid wasps of the genus *Streblocera* Westw. (Hymenoptera, Braconidae) of the southern Far East. *Entomologicheskoe Obozrenie* 66: 159-174.
- Belokobylskij, S. A. and D. S. Ku. 1998. Notes on the Korean species of the genus *Streblocera* with descriptions of a new species and a key to Korean species. *The Korean Journal of Systematic Zoology* 14: 319-325.
- Belshaw, R. and D. L. J. Quicke. In press. Assessing character transitions when estimates of phylogeny are uncertain: the evolution of koinobiosis on concealed hosts by ichneumonoid parasitoids. *Systematic Biology*.
- Chao, H. 1964. Descriptions of four new species of braconid wasps of the genus *Streblocera* Westwood (Hymenoptera). *Acta Zootaxonomica Sinica* 1: 153-162. (In Chinese with English summary.)
- Chen, X. and C. van Achterberg. 1997. Revision of the subfamily Euphorinae (excluding the tribe Meteorini Cresson) (Hymenoptera: Braconidae) from China. *Zoologische Verhandlungen* 313: 1-217.
- Chou, L.-Y. 1990. The Braconidae (Hymenoptera) of Taiwan II. The genus *Streblocera* (Euphorinae). *Journal of Taiwan Museum* 43: 89-148.
- Ku, D. S. 1997. A taxonomic study of the genus *Streblocera* Westwood from Korea. *Insecta Koreana* 14: 65-80.
- Maetô, K. and K. Nagai. 1985. Notes on braconid parasitoids of *Medythia nigrobilineata* (Motschulsky) (Coleoptera, Chrysomelidae), with description of a new species of *Centistes* Haliday (Hymenoptera: Braconidae). *Kontyu, Tokyo* 53: 729-733.
- Sharkey, M. J. and R. A. Wharton. 1997. Morphology and terminology. pp 19-37 in R. A. Wharton, P. M. Marsh and M. J. Sharkey (Eds) *Manual of the New World Genera of the Family Braconidae* (Hymenoptera). *Special Publication of the International Society of Hymenopterists*, No. 1.
- Shaw, S. R. 1985. A phylogenetic study of the subfamilies Meteorinae and Euphorinae (Hymenoptera: Braconidae). *Entomography* 3: 277-370.
- Shaw, S. R. 1988. Euphorine phylogeny: the evolution of diversity in host-utilisation by parasitoid wasps (Hymenoptera: Braconidae). *Ecological Entomology* 13: 323-335.
- Wang, J.-Y. 1983. A new species of *Streblocera* Westwood (Hymenoptera: Braconidae: Euphorinae). *Entomotaxonomia* 5: 231-232.

## The Afrotropical Species of *Leptomastidea* Mercet (Hymenoptera: Encyrtidae), Parasitoids of Mealybugs

G. L. PRINSLOO

Biosystematics Division, ARC-Plant Protection Research Institute, Private Bag X 134,  
Pretoria, 0001, South Africa

---

*Abstract.*—The Afrotropical mealybug parasitoids of the genus *Leptomastidea* Mercet (Encyrtidae) are revised and the following six species described as new: *ascia*, *lamto*, *pondo*, *tecta*, *turba* and *usta*. Diagnoses are provided for *L. abnormis* (Girault) and *L. jeanneli* Mercet, revised status, in addition to a key for the separation of females of the eight species of the genus known from the region.

---

*Leptomastidea* Mercet is an Old World genus, the species of which are all primary endoparasitoids of mealybugs (Homoptera: Pseudococcidae). The genus is particularly well known through *L. abnormis* (Girault), which has been used extensively in the biological control of the citrus mealybug, *Planococcus citri* (Risso), in several parts of the world, including countries in North and South America and Africa as well as Australia (Noyes and Hayat 1994). Undoubtedly, species of *Leptomastidea* also play a role in regulating mealybug populations in their native environment, as in the case of *L. usta* sp. nov., an indigenous species that is part of the complex of hymenopterous parasitoids associated with citrus mealybugs in certain areas of South Africa.

Apart from the six new species described below, *Leptomastidea* is known from 18 species worldwide, the majority of which are found in the Palaearctic and Oriental regions. A key to the Palaearctic species is provided by Trjapitzin (1989) and a detailed account of the Oriental fauna is given by Noyes and Hayat (1994). The Afrotropical fauna has not been studied in any detail before and was hitherto known from only four species: *L. abnormis* (Girault), *L. jeanneli* Mercet, *L. seyrigi* Ris-

bec and *L. ambositrensis* Risbec, the latter two species having since been transferred by Noyes and Hayat (1994) to *Homalotylus* Mayr and *Rhithidithorax* Ashmead respectively. *Leptomastidea jeanneli* was synonymized with *L. abnormis* by Noyes (2000) but is treated here as a valid species.

In addition to numerous specimens collected by sweeping and Malaise traps in West, East and southern Africa, the present study is based mainly on reared South African material. There are at least three apparently undescribed species among the material that have been excluded from this study because of the paucity of specimens, whereas the specific identity of several other specimens could not be determined with certainty. In view of the difficulties encountered during this study in interpreting the nature of certain variation it is felt that the identity of these specimens is best left in abeyance until additional material, especially host-reared series, become available.

The following acronyms are used in the text: BMNH (The Natural History Museum, London); MNCN (Museo Nacional de Ciencias Naturales, Madrid); NMK (National Museum of Kenya, Nairobi); SANC (South African National Collection of Insects, Plant Protection Research Institute, Pretoria).

### *Leptomastidea* Mercet

*Leptomastidea* Mercet 1916: 112. Type species  
*Leptomastidea aurantiaca* Mercet, by monotypy.

*Tanaomastix* Timberlake 1918: 362. Type-species  
*Paraleptomastix abnormis* Girault, by original designation.

A detailed account of the taxonomic status of *Leptomastidea*, including a diagnosis and key for separating it from other genera of the tribe Anagyrini, is provided by Noyes and Hayat (1994) and need not be repeated here. Suffice it to mention that *Leptomastidea* is most closely allied to *Gyrauusoidea* Compere, the eight Afrotropical species of which were treated by Prinsloo (1983). Noyes and Hayat (1994) state that, pending a phylogenetic analysis of the Anagyrini, these two genera may eventually be considered synonymous. Judging by the extent to which certain characters overlap between these genera in some extra-limital species there may be justification for such a step. However, as far as the Afrotropical fauna is concerned, the two genera can be readily delineated and I therefore agree with Noyes and Hayat (1994) that they should, at least for the time being, be treated separately.

Some of the Afrotropical species treated here are structurally very similar, especially in taxonomically important characters such as the shape and relative dimensions of the head, antenna, thorax, forewing venation and ovipositor, and in the setation and sculpture of the body. On the

other hand, these species differ markedly in the maculation of the forewing, the arrangement of fine and coarse setae on the wing disc and, in most cases, colour pattern of the body. The question is whether these differences merely represent infraspecific variation and whether those forms that are otherwise morphologically very similar should therefore be treated as geographical races (subspecies) or variants of the same species rather than distinct species. This is especially so in the case of *L. abnormis* (Girault) and *L. jeanneli* Mercet, and in the closely allied *L. truba* sp. nov. and *L. usta* sp. nov.

The likelihood of these differences being of an infraspecies nature has, however, been precluded here. In this regard wing maculation and setation in particular were found to be stable differentiating characters, both within populations and between geographically widely separated populations, with no evidence of any clinal or gradual variation being present. This, coupled to the fact that the forms in question are evidently sympatric, renders it unlikely that they are mere variants or races of the same species, and they are consequently regarded as representing distinct species. This does not imply that all observed differences in colour and wing maculation have been interpreted as being of an interspecific nature since infraspecific variation, usually in the form of colour differences within populations, is evidently also present, as is commonly found in various taxa of the Anagyrini.

---

#### KEY TO AFROTROPICAL SPECIES OF *LEPTOMASTIDEA* (based on females)

1. Forewing hyaline except for an oblique dark cross-band below submarginal vein and a dark patch at apex of venation; forewing setation uniform, not forming areas of fine and coarse setae (Fig. 1); hind coxa white ..... 8. *pondo* sp. nov.
- Forewing maculation different; forewing setation comprising areas of fine and coarse setae (Figs. 2–8); hind coxa brown to blackish-brown ..... 2
2. Forewing with a dark cross-band below submarginal vein and a second, broadly interrupted band below apex of venation, disc beyond venation hyaline but may appear slightly

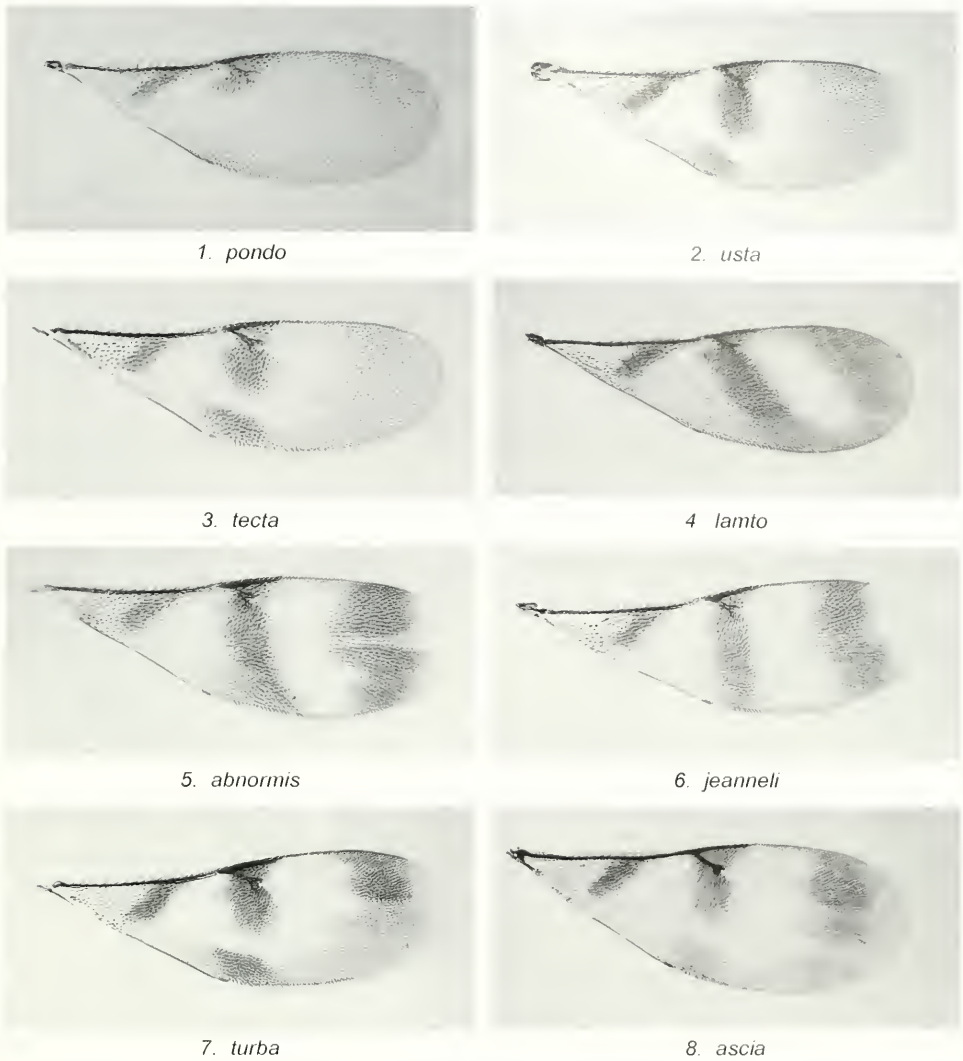

Figs.1-8. *Leptomastidea* spp., female (paratypes except in *abnormis* and *jeanneli*), forewing, showing maculation.

- darkened in part because of the presence of coarse dark setae (Figs. 2, 3); mesopleuron orange to red ..... 3
- Forewing maculation different, wing disc beyond venation partly infuscated (Figs. 4-8); mesopleuron always whitish, or pale with dusky suffusions ..... 4
- 3. Gena boldly marked with blackish-brown; ovipositor about as long as middle tibia (Fig. 17) ..... 4 *tecta* sp. nov.
- Gena white to yellowish without dark markings; ovipositor about half as long as middle tibia (Fig. 13) ..... 3 *usta* sp. nov.
- 4. Apical half of forewing fuscous with a large, oblique hyaline area extending from anterior wing margin to near posterior margin as in Fig. 4, extreme apex of wing (8) hyaline in some specimens; ovipositor about one-third as long as middle tibia (Fig. 20) ..... 7 *lamto* sp. nov.
- Apical half of forewing with maculation different (Figs. 5-8); ovipositor about half as long as middle tibia. .... 5

5. Forewing with dark cross-band below apex of venation broadly interrupted near posterior wing margin as in Figs. 7, 8 ..... 6  
 - Cross-band below apex of forewing venation complete or narrowly interrupted (Figs. 5, 6) ..... 7
6. Thoracic dorsum dark yellow to orange, gaster white basally, blackish apically; forewing about 3.0-3.3 X as long as broad, disc beyond venation hyaline with a large subapical dark patch at anterior wing margin as in Fig. 7 ..... 5. *turba* sp. nov.  
 - Thoracic dorsum and gaster entirely blackish-brown to black; forewing broader, less than 3 X times as long as wide, disc beyond venation with an interrupted subapical cross-band as in Fig. 8 ..... 6. *ascia* sp. nov.
7. Forewing with dark cross-band below apex of venation at right angles to anterior wing margin, parallel-sided; sub-apical cross-band entire, not interrupted in middle (Figs. 6, 9) ..... 2. *jeanneli* Mercet  
 - Cross-band below apex of venation not parallel-sided but broadening towards posterior wing margin; sub-apical cross-band interrupted in middle by a hyaline streak (Fig.5) ..... 1. *abnormis* (Girault)

### 1. *Leptomastidea abnormis* (Girault)

(Fig. 5)

*Paraleptomastix abnormis* Girault 1915: 184.

*Tanaomastix abnormis* (Girault): Timberlake 1918: 364.

*Leptomastidea abnormis* (Girault): Mercet 1924: 255-256.

*Leptomastidea aurantiaca* Mercet 1916: 113-116; Mercet 1924: 255 (synonymy).

*Diagnosis.*—*Female.* Head yellowish with face, temple and gena whitish in most specimens; antenna with radicle dark brown; scape white below, upper sides and dorsal aspect dark brown; pedicel with basal half dark brown, apical half white; flagellum brownish with basal two funicle segments and club usually darker than remaining segments. Thoracic dorsum yellowish with mesonotum strongly suffused with dark brown; propodeum dark brown; side of thorax largely whitish. Forewing with three dark cross-bands as in Fig. 5, intermediate one oblique, broadening towards posterior wing margin; both intermediate and sub-apical bands narrowly interrupted, former near posterior wing margin, latter in middle; sub-apical band distinctly broader than hyaline area separating it from apical wing margin. Legs whitish with middle and hind coxae brown and dorsal margin

of all femora darkly outlined; basal half of gaster whitish, apical half strongly suffused with dark brown.

*Male.*—*Colour:* much as in female except: legs entirely white, middle and hind coxae not dark; sub-apical cross-band on forewing faint, usually indistinct; gaster more extensively darkened.

*Material examined.*—KENYA: Sabukia, xi. 1931, H.C. James, ex *Pseudococcus citri* (= prob. *Planococcus kenyae* (Le Pelley)) on *Coffea arabica* (1 male, det. C. Ferrière). SENEGAL: locality unknown, v.1981, J. Etienne, ex *Ferrisia virgata* (Cockerell) (2 females, 2 males; T 6324). SOUTH AFRICA: Western Cape Province: Paarl, i.1975, G.L. Prinsloo, ex *Planococcus ficus* (Signoret) on grapes (3 females, 1 male; T 5153); Citrusdal, vi.1971, F. Honiball, ex *Planococcus citri* on citrus (2 females, 2 males; T 3854); same data except v.1971 (2 females, 2 males; T3808); Northern Province: Zebediela, vi.1966, H. Baas, ex mealybugs on citrus (3 females, 1 male; T 2342); Mpumalanga Province: Nelspruit, v.1972, H.P. Insley, with scale insects on *Maytemis* sp. (1 female, 1 male; T 4353); North West Province: Rustenburg, xi.1971, C.J. Cilliers, ex mealybugs on citrus (3 females, 1 male; T 4014); same data except i.1972 (5 females, 1 male; T 7110); Gauteng Province:

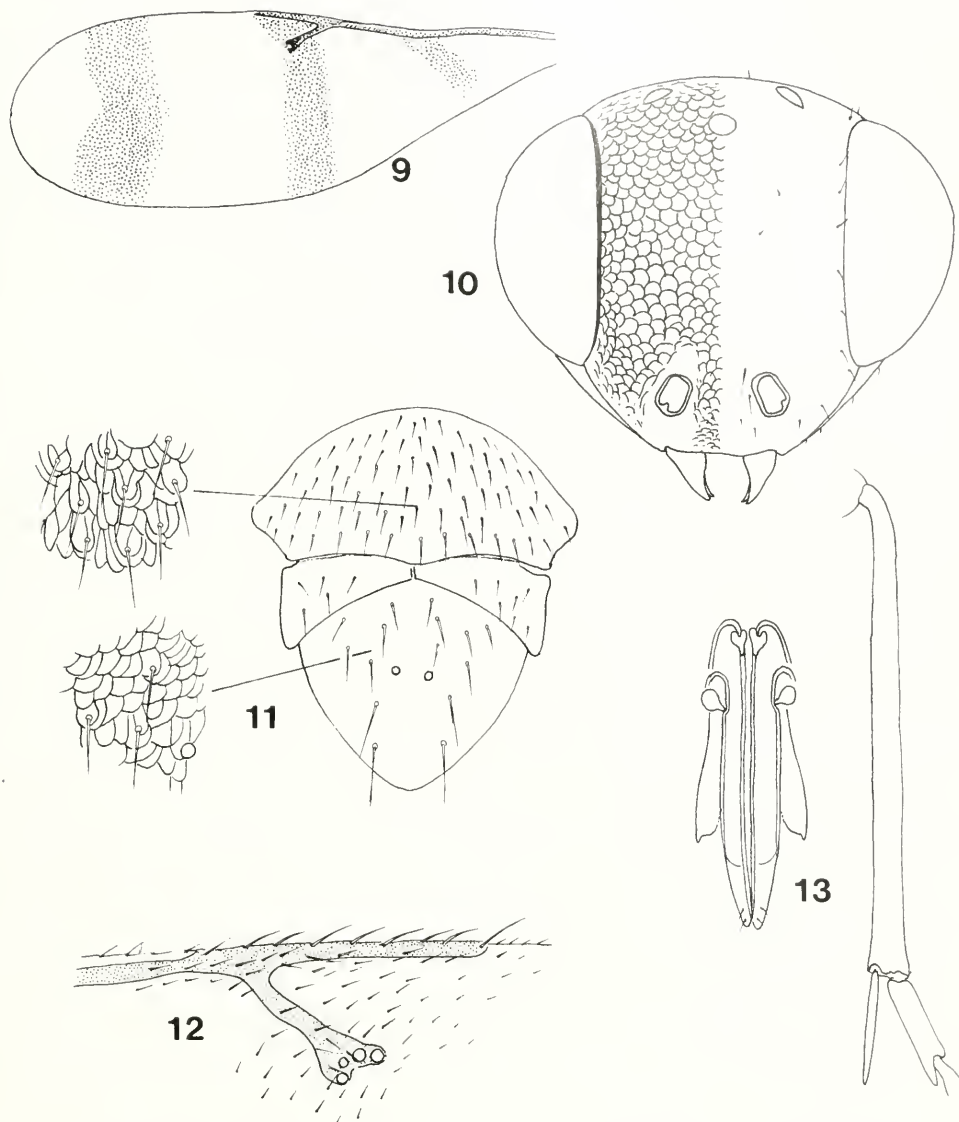

Figs. 9–13. *Leptomastidea* spp., females. 9, *L. jeanneli*, lectotype, forewing, showing maculation. 10–13, *L. usta*, paratypes. 10, Head, frontal view. 11, Mesonotum with sculpture of mesoscutum and scutellum enlarged. 12, Apex of forewing venation. 13, Ovipositor and middle tibia drawn to the same scale.

Pretoria, vi.1965, S.W. Broodryk, host unknown (1 female, 1 male; T 1980). UGANDA: Kiki, vii.1971, K. Ogwaro, with scale insects on citrus (1 female; T3912). All specimens in SANC.

*Extra-limital Material.*—AUSTRALIA: Palmwoods, Queensland, iii.1978, D. Murray, ex *Planococcus citri* on custard apple (6 females; T 5269). ISRAEL: Neot Haki-

kar, xi.1980, Y. Ben-Dov, with scale insects on *Phoenix dactylifera* (2 females, 1 male; T6232). USA: "Whittier, Calif. 1922, Rust, ex *Pseudococcus citri*" (10 females, 10 males; T 4274). All specimens in SANC.

*Remarks.*—This well known economically important species was originally described from Sicily and subsequently introduced to various parts of the world (in

many cases via laboratory stocks obtained from California) for the control of *Planococcus citri* and other mealybug species. A summary of the literature pertaining to the use of *L. abnormis* in biological control worldwide is provided by Noyes and Hayat (1994).

Within the African context, *L. abnormis* was imported into South Africa between 1934 and 1940 for the control of *Planococcus ficus* (thought to be *P. citri*) on grapes in the Western Cape Province where it became established. It was never deliberately released against *P. citri* on citrus but is now found in association with this pest throughout the citrus-growing areas of the country. Other introductions into Africa, which took place during the first half of the previous century and regarded as having been unsuccessful (see Noyes and Hayat 1994), were to Ghana and Kenya for the control of *Planococcoides njalensis* (Laing) and *Planococcus kenyae* respectively.

*Leptomastidea abnormis* has repeatedly been redescribed and illustrated in the literature, with recent accounts by Noyes (1988, 2000). Suffice it to mention that this species can be distinguished from its African congeners by the foregoing diagnosis and key. Its relationship with *L. jeanneli* Mercet, with which it was synonymized by Noyes (2000), is discussed in the treatment of the latter species below.

## 2. *Leptomastidea jeanneli* Mercet, revised status (Figs. 6, 9)

*Leptomastidea jeanneli* Mercet 1924: 256–258;  
Compere 1939: 25; Noyes 2000: 138 [as a junior synonym of *L. abnormis* (Girault)].

*Redescription.*—*Card-mounted female lectotype.* Length: 1.0 mm. *Colour:* Head entirely whitish, obviously faded; antenna uniformly blackish-brown except apical one-third or so of pedicel white. Thorax, propodeum and gaster blackish-brown except mesopleuron and prepectus whitish,

tegula white basally, darkly suffused apically. Forewing with three dark cross-bands as in Fig. 9, intermediate one at right angles to anterior wing margin, relatively narrow, parallel-sided, not somewhat oblique and broader towards posterior wing margin as in *L. abnormis*; intermediate and sub-apical bands not interrupted; sub-apical band subequal in width to hyaline area separating it from apical wing margin. Legs with fore coxa whitish, middle and hind coxae blackish-brown; legs otherwise whitish with hind femur entirely blackish-brown and fore and middle femora darkly outlined dorsally. *Head:* in dorsal view, twice as wide as frontovertex at median ocellus; ocelli in a right-angled triangle, lateral pair about twice own diameter from eye margins; head otherwise typical of genus, inner eye margins approximately parallel-sided, frontovertex with regular, raised reticulate sculpture; eyes appearing naked. Antenna with scape subcylindrical, about 5.5× as long as wide; pedicel as long as basal funicle segment; funicle segments subequal in length, basal one 3.5× as long as wide, remaining segments becoming progressively very slightly broader; club slightly longer than distal two funicle segments combined; linear sensillae discernible on funicle segment VI and club. Forewing 2.9× as long as wide; costal cell hardly discernible; basal triangle of wing disc densely and fairly coarsely setose except for a narrow bare streak below basal third of submarginal vein, this streak separated from submarginal vein by a single row of setae; areas of wing disc delineated by fuscous cross-bands with dark, fairly coarse setae, setae covering hyaline areas fine and pale, hardly visible under low magnification; postmarginal vein approximately 3× as long as marginal, a little less than twice as long as stigmal vein. Middle leg with tibial spur a little shorter than basal tarsal segment. General shape of thorax and gaster similar to *A. abnormis* and many other species of the genus,

sculpture and setation of thorax not clearly discernible in the card-mounted specimen, but appearing similar to that of the latter species.

*Variation.*—Female. At hand are a number of specimens from Zimbabwe, Kenya and various countries in West Africa which differ in colour from the female lectotype as follows: antenna with scape and flagellum not uniformly dark but scape bicolorous, whitish below, upper sides and dorsum blackish-brown, funicle entirely pale brown or with basal two or three segments distinctly darker, club blackish-brown; thoracic dorsum dominantly yellowish-brown; basal half or so of gaster white, apical half blackish-brown; legs, save dark middle and hind coxae, entirely whitish. Also available is a single additional specimen from Zimbabwe which, unlike these specimens, differs from the lectotype only in the paler thoracic dorsum and bicolorous antennal scape.

*Type material examined.*—Female lectotype (MNCN), designated by J.S. Noyes, with following data: “Naivasha, Africa or. Inglesa; *Leptomastidea jeanneli* Mercet, tipo; MNCN Cat. Tipo No. 10434”.

*Additional material.*—GHANA: Tafo, iv and v. 1973, M. Bigger, ex *Planocoides njalensis* (9 females BMNH). KENYA: “Don-yo, Sabuk, 1939, C 127, A.R. Melville, ex *Pseudococcus* sp. on *Combretum*, B.M. 1839–601, *Leptomastidea jeanneli* Mercet, det. Ferrière” (4 females; T 6621; SANC). NIGERIA: Ibadan, IIT Compound, xi.1987, J.S. Noyes (19 females; BMNH). TOGO: 5 km. W Amiame, 16.xii.1988, J.S. Noyes (1 female; BMNH). SÃO TOMÉ: xii.1974, J.O. Derron, ex *Planocoides njalensis* on cacao (1 female; T 4943; SANC). ZIMBABWE: Harare (= Rhodesia: Salisbury), xi.1974, ix.1976, ix.1979, iii.1984, A. Watsham (4 females; BMNH).

*Remarks.*—This species was originally described from an undisclosed number of female specimens from Naivasha, which is in Kenya, not Uganda as cited by Mercet (1924). The only known type specimen, a

lectotype designated by Noyes (1981), is in good condition and mounted on a card.

*Leptomastidea jeanneli* was recently synonymized with *L. abnormis* by Noyes (2000) who mentioned that the characters listed by Mercet (1924) for separating these two species fall within the range of variation found in *L. abnormis*. Although these two species are indeed very similar, I am nevertheless of the opinion that *L. jeanneli* should be resurrected as a valid species. I base this decision on the distinct difference in the shape of the fuscous crossbands on the forewing, as described above and shown in Figs. 5, 6 and 9. I do not believe that this difference reflects infraspecific variation, especially in view of the fact that the characteristic wing pattern in *L. abnormis* is not known to vary significantly, as is evident from the large amount of available study material and many published accounts of this geographically widespread and experimentally well known species.

The difference in body colour between the female lectotype of *L. jeanneli* and the specimens mentioned under “Variation” is attributed to infraspecific variation on the basis of the intermediate colour pattern of the single specimen from Zimbabwe. In this specimen the gaster, legs, and antennal flagellum are characteristic of the lectotype, whereas the antennal scape is bicolorous as in the other specimens from Zimbabwe and those from West Africa and Kenya. I am also of the opinion that, as far as the noted variation in colour is concerned, both the lectotype and intermediate specimen from Zimbabwe represent aberrant forms of *L. jeanneli*, the “normal” form being represented by the remaining specimens. Interestingly, the series from Kenya was identified as *L. jeanneli* by the late Ch. Ferrière, lending further support to the present interpretation of the taxonomic identity of the study material.

Compere (1939) recorded this species from a short series of specimens from

Kenya and a single female from Eritrea, none of which, according to Compere, are in complete agreement with Mercet's description of *L. jeanneli*. I have not seen these specimens.

### 3. *Leptomastidea usta* Prinsloo, new species

(Figs. 2, 10–15)

*Description.*—*Female.* Length: 0.7–0.9 mm. *Colour:* Head, thorax and propodeum entirely reddish-orange to red except temple, gena, mouth margin and area between scrobes white to yellowish; tegula white to reddish basally, brown apically; setae on frontovertex and mesonotum white. Antenna with radicle blackish-brown; scape white below, upper sides, and dorsal aspect from base to near apex, blackish-brown; basal half of pedicel blackish-brown, apical half white; flagellum usually brown to blackish-brown except funicle segments III–V or III–VI white; flagellum rarely entirely dark. Forewing (Fig. 2) with two dark cross-bands, basal one (below submarginal vein) strongly oblique, distal one (at apex of venation) broadly interrupted, wing disc beyond venation hyaline but appearing slightly darkened in part because of the presence of coarse dark setae; hind wing entirely hyaline. Legs with fore coxa whitish, middle and hind coxae blackish-brown; legs otherwise mostly whitish with dorsal margins of all femora darkly outlined, middle and hind tibiae also somewhat darkened in some specimens. Gaster white with apical third unevenly suffused with brown to blackish-brown, base also dark in some specimens. *Head:* in dorsal view, 1.7–1.9× as wide as frontovertex at median ocellus; ocelli in a right-angled triangle, lateral pair separated from inner eye margins by about twice own diameter; in frontal view (Fig. 10), about 1.2× as wide as long, malar space 0.5× eye length; with regular more or less circular sculptural cells as illustrated, the diameter of cells on frontovertex about the same as that of eye facet;

front aspect of head, and eyes, sparsely and finely setose, eyes appearing naked under low magnification, setae shorter than diameter of eye facet. Antenna (Fig. 15) with scape subcylindrical, approximately 5× as long as wide; pedicel ranging from as long as to 1.3× as long as basal funicle segment; funicle segments subequal in size, basal segment 2.5–3.1× as long as wide; club as long as distal two and a half funicle segments combined; linear sensillae on all club and distal two or three funicle segments. *Thorax:* typical of genus, dimensions, sculpture and setation of mesonotum as in Fig. 11. Forewing (Fig. 2) 2.8–3.3× as long as wide; costal cell narrow, barely discernible in basal half in most specimens, with a single row of setae on ventral margin; venation (Fig. 12) with postmarginal vein 1.3–1.6× length of stigmal, 2.5–3.0× as long as marginal, latter 0.5–0.6× length of stigmal vein; setae in area between the two fuscous bands and in a large patch beyond venation paler and much finer than remaining discal setae. *Ovipositor* (Fig. 13): 0.5–0.6× length of middle tibia; gonostyli 0.5–0.7× length of middle tibial spur, latter subequal in length to basal tarsal segment of middle leg.

*Male.*—*Colour:* Head with frontovertex orange, fading to yellow on face and gena; antenna with scape whitish except dorsal aspect brown; remainder of antenna brown. Thorax, propodeum and gaster dominantly dark brown to blackish-brown with yellowish-brown suffusions on sides of mesonotum. Forewing with an oblique pale brown band below submarginal vein as in female and a faint dark patch at apex of venation that does not form a cross-band. Legs much as in female. *Structure:* Differing from female mainly as follows: torulus placed higher on face, its lower margin more or less level with lower eye margins. Antenna (Fig. 14) with scape about 4.5× as long as wide; funicle segments subequal in length, each about 4× as long as wide; club unseg-

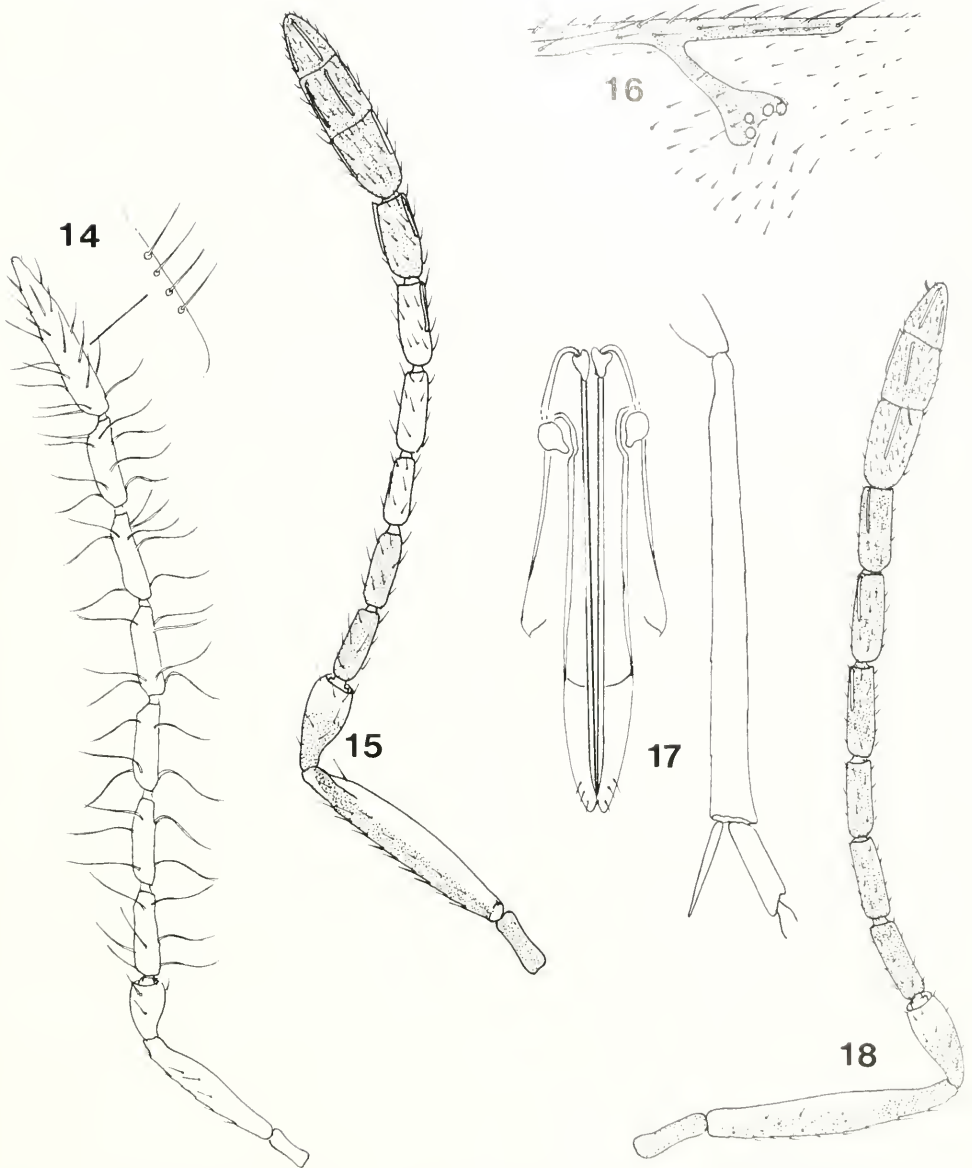

Figs. 14–18. *Leptomastidea* spp. 14–15. *L. usta*, paratypes. 14, Antenna and sub-basal row of spine-like setae on club, male. 15, Antenna, female. 16–18. *L. tecta*, female paratype. 16, Apex of forewing venation. 17, Ovipositor and middle tibia drawn to the same scale. 18, Antenna.

mented, as long as distal two funicle segments combined; funicle with long, curved setae, each about 3× as long as the width of a segment; club, apart from normal setation, with a longitudinal row of 3–4 short straight setae ventrally near base (Fig. 14). Forewing slightly broader than

in female, about 2.5× as long as wide; wing disc uniformly setose, not differentiated into areas with fine and coarse setae as in female. Phallosome less than half as long as middle tibia; tigli each terminating in two short, stout hooklets.

*Material examined*.—Female holotype, 29

female, 12 male paratypes as follows: BOTSWANA: Serowe, ix.1987, P. Forschhammer (1 female; BMNH). SOUTH AFRICA: Northern Province: Zebediela, vi-vii.1966, H. Baas, with *Nipacoccus viridis* (Newstead) and *Paracoccus buruerac* (Brain) on citrus (holotype, 5 females, 1 male; T 2343); Zebediela, vi.1981, M. van der Kooij, ex mealybugs on citrus (6 females, T 6307); Western Cape Province: De Doorns, 8.x.1968, V.B. Whitehead, ex mealybugs on *Elytropappus rhinocerotis* (L.f.) Less. (1 female, 6 males; T 2763); same data except H.P. Insley, 14.ii.1969 (1 female, 2 males; T 2976); Stellenbosch, ii.1969, H.P. Insley, ex mealybugs on *Stoebe vulgaris* Levyns (2 females; T2975); Stellenbosch, ix.1965, W.B. Whitehead, ex *Phenacoccus stelli* (Brain) on *Leucadendron daphnoides* (Thunb.) Meisn. (1 female; T 2019); Nature's Valley, iii.1970, H.P. Insley, ex mealybugs on *Metalasia muricata* (L.) D.Don (2 females; T 3407); Gauteng Province: Roodeplaat Dam, nr Pretoria, iii.1972, H.P. Insley, ex *Delottococcus quae-situs* (Brain) on *Acacia* sp. (2 females; T 4293); Kwazulu-Natal: Oribi Gorge, i.1972, H.P. Insley, ex mealybugs on *Cryptocarya weylliei* Stapf (4 females, 1 male; T 4191); Eastern Cape Province: Willowmore, i.1979, C. Kok, with *Tachardina* sp. on *Elytropappus rhinocerotis* (L. f) Less. (4 females, 2 males; T 7 111). ZIMBABWE: Harare (= Rhodesia; Salisbury), xi.1976, A. Watsham (1 female; BMNH). All specimens in SANC unless otherwise noted.

*Remarks.*—This widespread southern African species is readily separated in the female from its Afrotropical congeners, except *L. tecta*, by the striking reddish head and thorax and maculation of the forewing; it differs from *L. tecta* sp. nov. as mentioned in the treatment of that species below. *Leptomastidea usta* also resembles *L. rubra* Tachikawa, which is known from the Palaearctic region, closely in structure, body colour and general colour pattern of the forewing. The two species can, however, be distinguished by the

maculation of the forewing as follows: in *L. rubra* the infuscation at the apex of the venation forms a strongly oblique, incomplete band that extends about half-way across wing disc; in *L. usta* this band is almost at right angles to the anterior wing margin and, although broadly interrupted, extends across the entire width of the wing.

#### 4. *Leptomastidea tecta* Prinsloo, new species

(Figs. 3, 16–18)

*Description.*—*Female.* Length: 0.7–0.8 mm. *Colour:* Head brownish-yellow to pale orange with temple white, gena boldly marked with blackish-brown, this colour extending upwards onto hind margin of temple; setae on front aspect of head whitish. Antenna with radicle blackish-brown; scape with dorsal aspect and upper half of sides blackish-brown, otherwise white; pedicel with basal two-thirds blackish-brown, fading to white distally; flagellum entirely and uniformly blackish-brown. Thorax and propodeum orange except prepectus and collar of pronotum whitish, anterior margin of mesoscutum (partly obscured by pronotum) darkly suffused; tegula whitish to orange basally, dusky distally; thoracic setation silvery-white. Forewing (Fig. 3) with an oblique dark band below submarginal vein and a second, broadly interrupted one at apex of venation, disc beyond venation hyaline, appearing partly somewhat darkened because of the presence of coarse dark setae; hind wing entirely hyaline. Fore coxa mostly whitish, middle and hind coxae brown; fore leg white with dorsal and ventral margins of femur darkly outlined, tibia slightly embrowned in one specimen; middle and hind legs whitish with dorsal margin of femora darkly outlined and hind tibia with dusky suffusions, distal one or two tarsal segments dark. Gaster white with apical one-third or so blackish-brown, extreme base also darkly suffused in some specimens. *Head:* 1.8× as wide as

frontovertex at median ocellus, dimensions, sculpture and setation much as described and illustrated for *L. usta*. Antenna (Fig. 18) with scape  $5.5\times$  as long as broad; pedicel slightly longer than basal funicle segment; funicle segments subequal in length, basal segment  $3.0\text{--}3.3\times$  as long as wide; club as long as distal two and a half funicle segments combined; flagellum finely and fairly sparsely setose as in Fig. 18; linear sensillae present on club and distal three funicle segments in two slide-mounted specimens. *Thorax*: sculpture and setation not significantly different from that of *L. usta*. Forewing as in Fig. 3,  $3\times$  times as long as wide, arrangement of fine and coarse setae much as in *L. usta*; costal cell narrow but clearly discernible; venation (Fig. 16) with postmarginal vein  $1.3\text{--}1.4\times$  as long as stigmal, about  $3.2\times$  as long as marginal, latter  $0.5\times$  length of stigmal. *Ovipositor* (Fig. 17): unusually long, about as long as gaster and equal in length to middle tibia, gonostyli  $1.0\text{--}1.2\times$  as long as middle tibial spur.

*Male*.—*Colour*: Head with frontovertex dark yellow, fronto-occipital margin narrowly outlined in black; face and temple white, gena with a bold blackish-brown marking as in female. Antenna with scape bicolorous as in female, otherwise entirely brown. Thoracic dorsum dominantly blackish-brown except collar of pronotum white, side of mesoscutum and posterolateral margins of scutellum narrowly outlined in orange, metanotum orange; side of thorax with mesopleuron boldly marked with yellow or orange anteriorly, otherwise blackish-brown; prepectus white. Forewing hyaline with a pale brown oblique band below submarginal vein as in female and a large infuscated patch at apex of venation. Legs much as in female. Gaster entirely blackish. *Structure*: similar to male of *L. usta* except phallobase relatively longer, a little more than half as long as middle tibia.

*Material examined*.—Female holotype, 3 female, 4 male paratypes (SANC) as fol-

lows: SOUTH AFRICA: Eastern Cape Province: Georgida, xi. 1983, G.L. Prinsloo, ex *Lenania* sp. on *Salsola glabrescens* Burt Davy (T 7112).

*Remarks*.—This species, which is known only from South Africa, can be separated in the female from all the other Afrotropical species by the unusually long ovipositor, whereas the forewing maculation is unlike that of any of the extra-limital species. *Leptomastidea tecta* resembles *L. usta* closely in structure, colour and, perhaps most significantly, maculation and setation of the forewing. It differs from the latter species in the genae which are boldly marked with blackish-brown, the dimensions of the antennal segments, and ovipositor which is as long as the middle tibia, not half as long; correspondingly, the phallobase of the male of *L. tecta* is longer than in *L. usta*.

##### 5. *Leptomastidea turba* Prinsloo, new species (Figs. 7, 19–21)

*Description*.—*Female*. Length: 0.8–1.1 mm. *Colour*: Head with frontovertex dark yellow, fading to white on lower face, temple and gena, fronto-occipital margin very narrowly darkened; setae silvery-white. Antenna with radicle blackish-brown; scape with dorsal aspect and upper sides blackish-brown, otherwise white; pedicel blackish-brown basally, apical half white; flagellum either entirely dark brown to blackish-brown or with funicle segments III and IV slightly to distinctly paler than remaining flagellar segments, this variation present in same sample of reared specimens. Thoracic dorsum and propodeum ranging from dark yellow to orange, pronotal collar white sides of propodeum behind spiracles blackish-brown; tegula largely whitish, only apex dark; mesonotal setation silvery-white; side of thorax whitish. Forewing (Fig. 7) with an oblique fuscous cross-band below submarginal vein, a second, broadly interrupted one below apex of venation and a

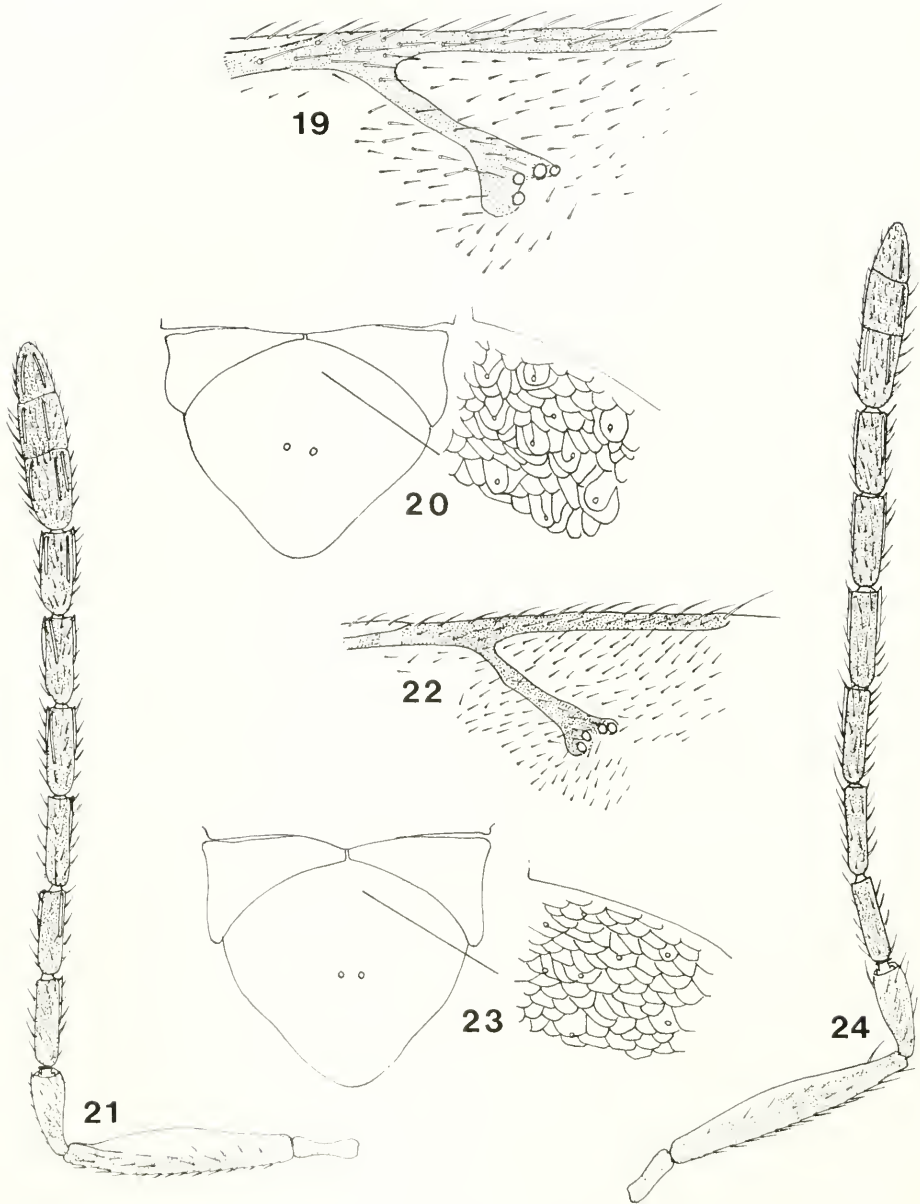

Figs. 19–24. *Leptomastidea* spp., female paratypes. 19–21. *L. turba*. 19, Apex of forewing venation. 20, Scutellum with sculpture enlarged. 21, Antenna. 22–24. *L. ascia*. 22, Apex of forewing venation. 23, Scutellum with sculpture enlarged. 24, Antenna.

large infuscated patch at anterior margin near apex of wing, setae below this infuscated patch darkened, but not wing membrane; hind wing hyaline. Legs whitish except middle and hind coxae, dorsal margins of femora usually, and tarsal tips,

brown to blackish-brown; gaster with basal half or so white, apical half blackish. *Head*: 1.9–2.1× as wide as frontovertex at median ocellus; lateral ocelli about twice own diameter from inner eye margins; eye a little more than twice as long as malar

space; sculpture much as described and illustrated for *L. usta*, diameter of cells on frontovertex about equal to that of eye facet; frontovertex from median ocellus to occipital margin with numerous scattered setae, remainder of front aspect of head sparsely setose; eyes finely and inconspicuously setose, setae shorter than diameter of eye facet. Antenna (Fig. 21) with scape 4.7–5.0× as long as broad; pedicel subequal in length to basal funicle segment; funicle segments subequal in length, basal one 3.0–3.5× as long as wide; club slightly longer than distal two funicle segments combined; funicle usually with linear sensillae on all except basal one or two segments, rarely present on all segments. *Thorax*: dimensions, sculpture and setation of mesonotum much as in *L. usta*, cells on anterior part of scutellum irregular in shape, as shown in Fig. 20. Forewing (Fig. 7) about 3× as long as wide; costal cell very narrow, indiscernible in some specimens; venation (Fig. 19) with postmarginal vein 1.3–1.4× as long as stigmal, about 3.5× length of marginal vein, latter 0.5× as long as stigmal; wing disc densely and evenly setose, arrangement of fine and coarse setae as illustrated. *Ovipositor*: almost 0.5× length of middle tibia, gonostyli 0.5× as long as middle tibial spur.

*Male*.—*Colour*: Differing from female mainly as follows: mesonotum not uniformly dark yellow but suffused with blackish-brown to a varying degree, gaster entirely blackish, its basal half not white; forewing with infuscation below apex of venation not forming a well defined interrupted cross-band, but appearing as two faint patches, one directly below venation, the other at posterior wing margin; disc beyond venation hyaline, without a subapical infuscated patch. Similar to male of *L. usta* in colour and structure, differing only in presence of a faint fuscous patch at posterior margin of forewing.

*Variation*.—At hand are several female specimens collected by sweeping from the same locality (Harare) in Zimbabwe.

These specimens have been excluded from the type material, from which they differ as follows: front aspect of head entirely yellow, not fading to white on face and gena; funicle segments III–V white in contrast to remaining flagellar segments, which are blackish-brown; side of thorax not entirely white, mesopleuron with dusky suffusions; legs with femora entirely pale, dorsal margins not outlined in blackish-brown; scutellum anteriorly with sculptural cells more regular in shape than shown in Fig. 20; forewing narrower, about 3.3× as long as wide.

These differences are here attributed to infraspecific variation, although further material, including reared series of both sexes, is required to determine the exact nature of the variation seemingly present in *L. turba*. This is especially important in view of the presence of a further specimen from Harare which, unlike the above-mentioned material from this locality, does not differ from the type specimens.

*Type material examined*.—Female holotype, 36 female, 13 male paratypes as follows: NAMIBIA: Otavi, ii.1978, C. Kok ex mealybugs (10 females, 1 male; T 7114); Chorixas, ii.1978, C. Kok ex mealybugs on *Welwitschia mirabilis* Hook. f. (3 females; T 6061). SOUTH AFRICA: Gauteng Province: Pretoria, iv.1995, O.C. Nesor, ex *Paracoccus burnerae* on *Senecio venosus* Harv. (holotype, 16 females, 11 males; T 7113); same data except xi.1988, S. Nesor (3 females, 1 male; T 6978). ZAMBIA: 15 KM e Lusaka, 11–19 and 20–31.ii.1980, R.A.Beaver (3 females; BMNH). ZIMBABWE: Harare, vii.1982, A. Watsham (1 female; BMNH). Holotype and paratypes in SANC unless otherwise noted.

*Non-type material*.—ZIMBABWE: Harare (= Rhodesia: Salisbury), vi.1978, i–iii and viii.1979, xi.1980, A. Watson, by sweeping (23 females; BMNH).

*Remarks*.—This widespread southern African species can be separated, in the female, from all other species of the genus by the maculation and setation of the fore-

wing. Structurally it is very similar to *L. usta*, from which it seems to differ only in the presence of linear sensillae on one or more of the basal three funicle segments. Apart from the difference in wing maculation, the female of *L. turba* also differs from *L. usta* in the colour of the head and thoracic dorsum which are paler, and the mesopleuron which is white, or white with dusky suffusions, not reddish.

**6. *Leptomastidea ascia* Prinsloo, new species**  
(Figs. 8, 22–24)

*Description*.—*Female*. Length: 1.1–1.4 mm *Colour*: Frontovertex orange, fronto-occipital margin broadly suffused with blackish-brown, remainder of front aspect of head white with gena slightly darkened; setae on frontovertex and eyes dark. Antenna uniformly blackish-brown except ventral aspect and lower sides of scape, and apex of pedicel, white. Thorax and propodeum blackish-brown to almost black except: pronotal collar and prepectus white, tegula whitish basally, otherwise dark, mesopleuron entirely whitish, or with dusky suffusions; mesonotal setae silvery-white. Forewing with three fuscous cross-bands as in Fig. 8, basal one oblique, intermediate one (at apex of venation) at right angles to anterior wing margin, parallel-sided, broadly interrupted, the sub-apical band with two narrow interruptions; hind wing hyaline with a narrow oblique brownish cross-band near base. Fore coxa white, middle and hind coxae blackish-brown; legs otherwise usually sordid white with dorsal margins of all femora dark; in some specimens the femora, tibiae, and tarsi are more extensively darkened. Gaster entirely blackish-brown. *Head*: about twice as wide as frontovertex at median ocellus; lateral ocellus 1.5–2.0× its diameter from lateral eye margin; head with shape and sculpture otherwise much as illustrated for *L. usta*; frontovertex fairly densely and strongly setose; eye densely and strongly setose, se-

tae readily discernible under low magnification, each seta about as long as the diameter of eye facet. Antenna (Fig. 24) with scape just more than 6× as long as wide; pedicel subequal in length to basal funicle segment; funicle segments subequal in length, basal segment about 3.5× as long as wide; club as long as distal two funicle segments combined; funicle segments III–VI and club with linear sensillae. *Thorax*: shape of sculptural cells on anterior part of scutellum as in Fig. 23, more regular in shape than in the other species treated here. Forewing (Fig. 8) 2.7–2.8× as long as broad; costal cell relatively broad, clearly visible along its entire length with a single row of setae ventrally; venation (Fig. 22) with postmarginal vein 1.6× as long as stigmal, 3× as long as marginal, latter 0.5× as long as stigmal; setae (save those at base) confined to hyaline areas of disc finer and paler than those of infuscated areas. *Ovipositor*: 0.5× length of middle tibia; gonostyli 0.6× as long as middle tibial spur, latter subequal in length to basal tarsal segment of middle leg.

*Male*.—*Colour*: as in female except frontovertex more extensively suffused with blackish-brown, and infuscated areas on forewing paler, sub-apical cross-band indistinctly delineated. *Structure*: Differing from female mainly by slightly broader forewing, which is about 2.5× as long as broad, and antenna; antenna similar to that of male of *L. usta*, as shown in Fig 14; digiti of phallobase each terminating in two short, stout hooklets.

*Material examined*.—Female holotype, 55 female, 17 male paratypes as follows: KENYA: "Aberdare NP, 0.23S 36.46E, 10–18.ii.1999, T.Wagner, Canopy fog Podocarpus latifolius, BMNH 1999–279" (holotype, 27 females, 7 males); "Gatamayu, Kikuyu Esc. 2320m, 0.58S 36.42E, T.Wagner, ii.99, Canopy fog Podocarpus latifolius, BMNH (E) 1999–279" (26 females 7 males); "1600m, Mt Kenya NP (WHQ), 0.10S 37.10E, ii.1999, T, Wagner, Canopy fog Podocarpus latifolius, BMNH (E) 1999–279"

(2 females, 3 males). Holotype and paratypes in NMK; paratypes in BMNH and SANC.

*Remarks.*—The three series on which this new species is based are all from central Kenya where they were collected (by fogging) on *Podocarpus latifolius* (Thunb.) R.Br. ex Mirb., a gymnosperm which is widespread in southern and East Africa. The mealybug host of this material is unknown, but may be *Eastia jouberti* De Lotto, the only species of mealybug known to be associated with this tree in sub-Saharan Africa.

*Leptomastidea ascia* appears to be most closely allied to *L. usta* and *L. turba* and, as in these two species, the cross-band at the apex of the fore wing venation is broadly interrupted. The wing pattern beyond the venation in these three species is, however, different. In addition, *L. ascia* is distinguished from *L. usta* and *L. turba* by its larger size, entirely blackish thoracic dorsum and abdomen, dark setae on frontovertex, densely pubescent eyes, and difference in the shape of the sculptural cells of the scutellum.

**7. *Leptomastidea lamto* Prinsloo, new species**  
(Figs. 4, 26–27)

*Description.*—*Female.* Length: 0.7–1.1 mm. *Colour:* Head with frontovertex dark yellow from occipital margin to just above upper limits of scrobes, lower part of head white; setae on frontovertex dark. Antenna, save white apex of pedicel, either entirely dark brown or with scape white below along its entire length. Thoracic dorsum variable: more or less concolorous with frontovertex or with entire mesonotum, or axillae and scutellum only, with brown to blackish-brown suffusions; tegula whitish basally, apical half dark; propodeum largely blackish-brown; side of thorax with prepectus white, mesopleuron whitish, with darker suffusions in most specimens; mesonotal setae whitish. Forewing with an oblique dark cross-bands be-

low submarginal vein; disc from level of apex of venation fuscous with a large oblique hyaline area extending from anterior wing margin to near posterior margin, as shown in Fig. 4; in some specimens extreme apex of wing also hyaline; hind wing palely infuscated near base and along anterior margin beyond venation. Legs whitish except middle and hind coxae blackish-brown, dorsal margins of all femora, and hind tarsus, with brownish suffusions in some specimens. Gaster whitish with syntergum and apex blackish-brown. *Head:* 2.0–2.3× as wide as frontovertex at median ocellus; ocelli in an approximately right-angled triangle, lateral pair separated from inner eye margins by slightly more than own diameter; head with dimensions and sculpture otherwise much as illustrated for *L. usta*; eyes fairly densely but very finely setose, appearing naked under low magnification, setae about as long the diameter of eye facet; frontovertex from median ocellus to occipital margin with numerous long, dark setae extending along entire length of each inner eye margin in a single row; front aspect of head otherwise finely and sparsely setose. Antenna (Fig. 27) with scape about 5.7× as long as wide; pedicel ranging from slightly shorter to as long as basal funicle segment; funicle segments subequal in length, basal segment about 4× as long as broad; club as long as distal two funicle segments combined; linear sensillae present on club and funicle segments III–VI. *Thorax:* dimensions, sculpture and setation of mesonotum much as described and illustrated for *A. usta*. Forewing (Fig. 4) 2.7–3.3× as long as wide; costal cell very narrow, hardly discernible in some specimens; venation (Fig. 25) with postmarginal vein 1.5–2.0× long as stigmal, about 3.3× the length of the marginal vein; disc with setae confined to the large hyaline area beyond venation much finer, shorter and paler than setae on remainder of disc. *Ovipositor* (Fig. 26): one-third length of middle tibia; gonostyli 0.5 X

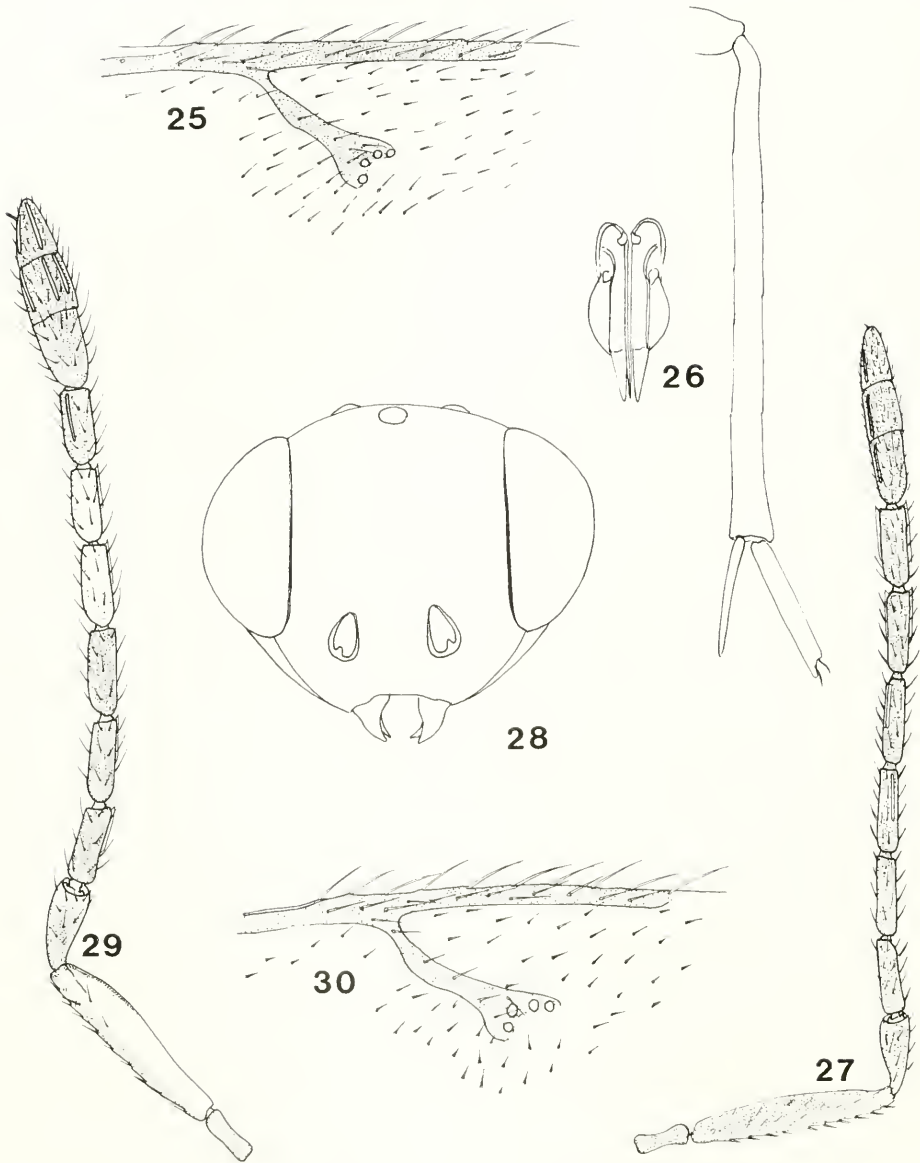

Figs. 25–30. *Leptomastidea* spp., female paratypes. 25–27. *L. lamto*. 25, Apex of forewing venation. 26, Ovipositor and middle tibia drawn to the same scale. 27, Antenna. 28–30. *L. pondo*. 28, Head, frontal view. 29, Antenna. 30, Apex of forewing venation.

length of middle tibial spur, latter slightly shorter than adjacent tarsal segment.

*Male*.—Unknown.

*Material Examined*.—Female holotype, 32 female paratypes as follows: CAMEROON: Nkoemvon, viii.1979, D. Jackson (1 female); Victoria Bot. Gardens, 6.xii.1981, Compton (1 female). GABON:

Forêt de la Mondah, 15–25 km N. Libreville, 25.xi–3.xii.87, J.S. Noyes (1 female); Forêt de Sibang, 5km E. Libreville, 30.xi–2.xii. 87, J.S. Noyes (1 female). IVORY COAST: Lamto, 6.13N 5.02W, xi.1988, J.S. Noyes (holotype, 14 females); Sassandra, 26.ii–1.iii.1984, M. Matthews (1 female); Gagnoa, Antonihio, 2–5.iii.1985, M. Mat-

thews (2 females). NIGERIA: Ibadan, Oyo St., IITA compound, xi.1987, J.S. Noyes (10 females). TOGO: 10 km NW Kapalimé, xii.1988, J.S. Noyes (1 female). Holotype and paratypes in BMNH; paratypes in SANC.

*Remarks.*—This species, which is evidently widespread in West Africa, is separated from its congeners by the distinct maculation of the forewing, in addition to a combination of characters which include the generally yellow to brown colour of the head and thorax, uniformly dark brown antennal flagellum, relatively narrow frontovertex and placement of the ocelli, slender funicle segments and short ovipositor, as described above.

**8. *Leptomastidea pondo* Prinsloo, new species**

(Figs. 1, 28–30)

*Description.*—*Female.* Length: 0.8–0.9 mm. *Colour:* Head with frontovertex from occipital margin to near upper limits of scrobes yellow, lower part of head white; setae on frontovertex silvery-white. Antenna with radicle brown; scape largely whitish, suffused with brown dorsally along its entire length, ventral margin darkened at apex; pedicel brown with apex whitish; funicle segments I–III brown, IV–V whitish, VI brown but slightly paler than basal three segments; club brown. Thoracic dorsum with pro- and mesonotum yellow, metanotum whitish; propodeum whitish with brownish suffusions posteriorly; tegula white save slightly darkened apex; thoracic setation silvery-white; side of thorax white. Forewing hyaline except for a pale oblique fuscous cross-band below submarginal vein and dark patch at apex of venation, as in Fig. 1. Legs white except middle coxa and tarsal tips dark brown. Gaster with basal two-thirds or so white, apical third dark brown. *Head:* (Fig. 28) 1.7× as wide as frontovertex at median ocellus; ocelli in a right-angled triangle, lateral pair separated from inner eye margins by about twice

their own diameter; head otherwise with sculpture and setation much as described and illustrated for *L. usta*. Antenna (Fig. 29) with scape 4.6× as long as wide; pedicel subequal in length to basal funicle segment; funicle segments subequal in length, segment 1 3× times as long as wide; club as long as distal two and a half funicle segments combined; club and all six funicle segments with linear sensillae. *Thorax:* dimensions, sculpture and setation of mesonotum much as in *L. usta*. Forewing (Fig. 1) 2.7–2.8× as long as wide; costal cell narrow in its basal one-third, not discernible in apical two-thirds; venation (Fig. 30) with postmarginal vein 1.6× length of stigmal, 3.3–3.5× as long as marginal, latter 0.5× as long as stigmal; wing disc fairly evenly and densely setose from base to apex, setation uniform throughout, not divided into areas of fine and coarse setae as in most other species of genus. *Ovipositor:* slightly distorted in single slide-mounted specimen, appearing about 0.5× length of middle tibia, gonostyli 0.5× as long as middle tibial spur, latter subequal in length to basal tarsal segment of middle leg.

*Male.*—*Colour:* Head and thorax much as in female; antenna with scape largely whitish, otherwise entirely dark brown; forewing patterned as in female; legs entirely whitish except dark tarsal tips, middle coxa very slightly embrowned; gaster entirely dark brown. *Structure:* Differing from female mainly in toruli which are placed higher on face, eyes which are slightly smaller and antennal shape: antenna with funicle segments subequal in size, tapering strongly at their apical ends, basal segment 5× times as long as broad; funicle clothed with whorls of long, curved setae, each seta approximately 5× as long as the width of a segment; club as long as distal two funicle segments combined with a longitudinal row of four spine-like setae near base. Phallobase one-third length of middle tibia in single slide-mounted paratype.

*Material examined*—Female holotype, 5 female, 3 male paratypes (SANC) as follows: SOUTH AFRICA: KwaZulu-Natal Province; Port Edward, i.1972, H.P. Insley, ex mealybugs on *Maytenus undata* (Thunb.) Blakelock (T 4166).

*Remarks*.—*Leptomastidea pondo*, which is known only from South Africa, differs in the female from other species of the genus by the forewing which is mostly hyaline except for the presence of a cross-band below submarginal vein and dark patch at apex of venation. It can be distinguished further from its Afrotropical congeners in the female by the generally pale yellow appearance, white hind coxa, broad frontovertex, and uniformly setose forewings.

#### ACKNOWLEDGEMENTS

I thank J.S. Noyes (BMNH) and J.L. Nieves Aldrey (MNCN) for the loan of specimens and my colleague Otilie Nesor for technical assistance and reading the manuscript. The digital photographs of the wings were taken by Alan Hall, University of Pretoria, and Elsa van Niekerk, PPRI, kindly assisted in preparing them for publication.

#### LITERATURE CITED

- Compere, H. 1939. A second report on some miscellaneous African Encyrtidae in the British Museum. *Bulletin of Entomological Research* 30: 1–26.
- Girault, A. A. 1915. Four new encyrtids from Sicily and the Philippines. *Entomologist* 48: 184–186.
- Mercet, R. G. 1916. Chalcididos de Espana. *Boletín de la Real Sociedad Española de Historia Natural* 16: 112–117.
- Mercet, R. G. 1924. Los géneros *Leptomastidea*, *Callipteroma* y *Cyranusa*. *Boletín de la Real Sociedad Española de Historia Natural* 24: 252–260.
- Noyes, J. S. 1981. On the types of the species of Encyrtidae described by R. Garcia Mercet (Hymenoptera: Chalcidoidea). *Eos, Madrid* 55/56: 165–189.
- Noyes, J. S. 1988. Encyrtidae (Insecta: Hymenoptera). *Fauna of New Zealand* 13: 1–188.
- Noyes, J. S. 2000. Encyrtidae of Costa Rica (Hymenoptera: Chalcidoidea), I. *Memoirs of the American Entomological Institute* 62: 1–355.
- Noyes, J. S. and M. Hayat. 1994. *Oriental mealybug parasitoids of the Anagyrini (Hymenoptera: Encyrtidae)*. CAB International, Wallingford, UK, i-viii + 554 pp.
- Prinsloo, G. L. 1983. The southern African species of *Cyranusoidea* Compere (Hymenoptera: Encyrtidae). *Journal of the Entomological Society of Southern Africa* 46: 103–113.
- Timberlake, P. H. 1918. New genera and species of Encyrtidae from California parasitic in mealybugs (Hymenoptera). *University of California Publications in Entomology* 1: 347–367.
- Trjapitzin, V. A. 1989. *Parasitic Hymenoptera of the fam. Encyrtidae of Palaearctics*. Opredeliteli po faune SSSR, Izdavayemyie Zoologicheskim institutom AN SSSR 158. Leningrad, Nauka, Leningrad Division, 488 pp. (in Russian).

## Investigation of the Biology of Hymenoptera Associated with *Fergusonina* sp. (Diptera: Fergusoninidae), a Gall Fly of *Melaleuca quinquenervia*, Integrating Molecular Techniques

J. A. GOOLSBY, C. J. BURWELL, J. MAKINSON, AND F. DRIVER

(JAG) United States Department of Agriculture, Agricultural Research Service, Australian Biological Control Laboratory, CSIRO Long Pocket Laboratories, 120 Meiers Rd. Indooroopilly, QLD, Australia 4068 (email: john.goolsby@brs.ento.csiro.au); (CJB) Queensland Museum, P.O. Box 3300, South Brisbane, QLD, Australia 4101; (JM) Commonwealth Scientific and Industrial Research Organisation (CSIRO), Division of Entomology, Australian Biological Control Laboratory, 120 Meiers Rd. Indooroopilly, QLD, Australia 4068; (FD) CSIRO Entomology, Black Mountain Laboratories, GPO Box 1700, Canberra, ACT, Australia 2601

---

*Abstract.*—The biologies of eleven species of Hymenoptera associated with the multi-ocular galls of the fly, *Fergusonina* sp. (Fergusoninidae) were investigated. More than 2000 wasps were reared from 1100 galls collected in Queensland and New South Wales, Australia over a two-year period from 1997 to 1999 from *Melaleuca quinquenervia* (Myrtaceae). Additional galls from each site were dissected for observation and description of the immature stages. A molecular technique, which involved sequencing the D2 expansion domain of the 28S rRNA gene, was used to match the identity of the immature wasps with their adult forms. Of the eleven species of Hymenoptera associated with the *Fergusonina* sp. galls, we were able to observe and describe the biology of nine of the species. *Eurytoma* sp., *Coelocyba* sp., *Neanastatus* sp., *Cirrospilus* sp., *Bracon* sp., *Megastigmus* sp. and *Poecilocyrtus nigromaculatus* Cameron, commonly or exclusively, fed directly upon the *Fergusonina* larvae and or pupae with most species developing on a single host. However, *Eurytoma* sp., *Bracon* sp., and *P. nigromaculatus* usually fed on multiple hosts. These species have specialized biologies, which enable them to chew through plant tissues to access gall inhabitants. *Chromeurytoma* sp. and *Euderus* sp. appeared to be hyperparasitoids based on the available evidence. The biological control implications of this suite of Hymenoptera are discussed in terms of their regulatory effect on *Fergusonina* sp., a potential biological control agent of *M. quinquenervia*, an invasive weed in Florida, USA.

---

Species of *Fergusonina* (Fergusoninidae) and their associated *Fergusobia* nematodes (Tylenchida: Sphaerulariidae), together form galls on the buds of their myrtaceous host plants (Currie 1937, Ferrar 1987, Giblin-Davis 2000). An undescribed species of *Fergusonina* and an undescribed *Fergusobia* form vegetative and floral galls on the broad-leafed paperbark tree, *Melaleuca quinquenervia* (Cavanilles) S.T. Blake (Fig 1). This *Fergusonina* sp. is present throughout the Australian distribution of *M. quinquenervia*, which stretches along the east coast from southern New South Wales (NSW), to the far north of Queensland

(QLD). The gall-making cyclorrhaphous fly is under study as a potential biological control agent for *M. quinquenervia*, which was introduced from Australia into Florida in the United States in the early 1900's. In the last 30–40 years *M. quinquenervia* has greatly expanded its range in southern Florida, including the ecologically sensitive Everglades, where it now infests over 200,000 hectares causing extensive environmental and economic damage (Turner *et al.* 1998).

The seasonal phenology of *Fergusonina* sp. on *M. quinquenervia* was investigated by Goolsby *et al.* (2000a) over a two-year

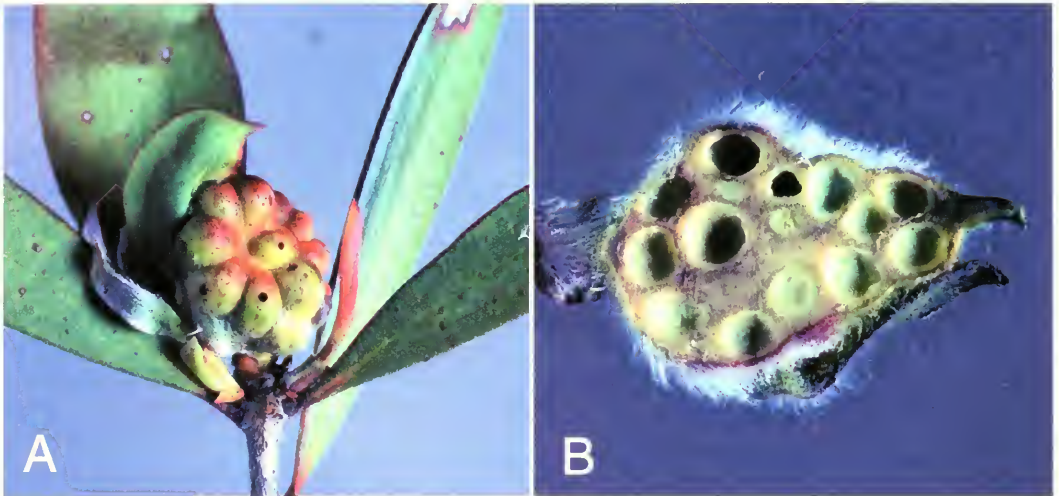

Fig 1. *Fergusonina* sp. gall on *Melaleuca quinquenervia*; a, Intact gall showing cluster of chambers, some with exit holes, and b, cross-section of gall showing individual chambers of the fly larvae.

period between 1997 and 1999. The study indicated that biotic factors, including parasitism, might have a significant effect on *Fergusonina* sp. gall density. Data collected for emergence of flies and associated gall inhabitants revealed numerous Hymenoptera, comprising nine species of Chalcidoidea and a single species each of Braconidae and Ichneumonidae, all potential parasitoids of the *Fergusonina* sp. In order to understand the impact of parasitism, we first needed to establish which species of wasps are primary parasitoids of the *Fergusonina* sp., which are hyperparasitoids or inquilines and which can behave as both primary parasitoids and hyperparasitoids. A large complement of primary parasitoid species may indicate that parasitism plays a significant role in regulating *Fergusonina* sp. populations in Australia. Understanding the regulatory effect of natural enemies on a potential biological control agent in its native range is a useful predictor of its success in its adventitious range.

In his pioneering work on the Fergusoninidae, Currie (1937) postulated that parasitic Hymenoptera played a major role in regulating their population dynamics. He reared many species of wasps from flower

bud galls produced by *Fergusonina nicholsoni* Tonnoir on *Eucalyptus macrorhyncha* F. Mueller ex. Benth and dissected galls to determine the biologies of their immatures. Currie noted that both a chalcidoid and a braconid were true parasitoids of the gall-making flies and briefly listed four other species of chalcidoid wasps that formed independent chambers within the galls. However, more detailed information on the biologies of the gall-associated wasps was never published. Taylor *et al.* (1996) reared twelve species of wasps from leaf galls formed by *Fergusonina flavicornis* Malloch on *Eucalyptus camaldulensis* Dehnhardt in South Australia. They did not dissect galls, but discussed the probable biologies of the various wasp species in the light of their relative abundance and the biologies of related species. Both studies found an abundance of gall-associated Hymenoptera, but were largely unable to positively determine their role inside the gall.

Gall-making agents interact with associated parasitoids, predators and inquilines behind the cover of plant tissue that often obscures our understanding of their biologies. Because it may be difficult to identify the hymenopteran larvae associ-

ated with galls, many studies fail to associate the biology of the immatures with their adult form (Shorthouse *et al.* 1990, Manongi and Hoffman 1995). The most common method for determining the biology of immatures is to observe them in the gall and then hold them until they emerge as adults, which can be more easily identified. This method is the most straightforward and has been used widely in the study of gall inhabiting Hymenoptera.

However, this method is time consuming and may not be practical when dealing with galls that contain a large suite of parasitoid species. In our study we also dissected and observed gall contents, but combined this method with a molecular technique which involved sequencing the D2 expansion domain of the 28S rRNA gene to match the identity of the wasp larvae with their adult forms. The D2 expansion domain of the 28S rRNA gene has been used in other studies to separate cryptic species of adult hymenopteran parasitoids (De Barro *et al.* 2000, Babcock and Heraty 2000), and aquatic weevils (Goolsby *et al.* 2000b). Tilmon *et al.* (2000) used the COI gene to determine species composition of immature parasitoids in their host. We used the molecular method of sequencing the D2 gene as a way to determine identity of the immatures as we observed their biology *in vivo*.

## MATERIALS AND METHODS

Monthly collections of mature *Fergusonia* sp. galls on *M. quinquenervia* trees were made from Peregian and Morayfield (QLD) and Woodburn (NSW) from July 1997 to September 1999. The locations and phenology of the *Fergusonia* sp. are described in Goolsby *et al.* (2000a). Galls were held for one month in ventilated containers for emergence of the gall inhabitants. The emerged insects were counted and sorted to species.

In September 1999, following the two-year study, approximately 30 galls were

collected from each site in order to observe and investigate the biology of the gall inhabitants. We dissected several hundred gall chambers in order to observe the behavior of the gall inhabitants. Observations of the gall insects were made using a dissecting microscope, and pictures of the contents were taken using a digital camera (Sony Mavica, model FD-88). Owing to the mobility of the camera, pictures of immatures could be taken by focusing through the ocular of the microscope. Immatures were placed in vials of 95% alcohol for DNA analysis. Several specimens of each species were analyzed. Adult parasitoids were identified to genus and, where possible, to species. Vouchers are located in the Queensland Museum, Brisbane; Florida State Collection, Gainesville and the U.S. National Museum, Washington, D.C.

Eggs, larvae, and pupae of Hymenoptera were used for gene sequencing. Gene sequences of the immature Hymenoptera were compared with adults that had been reared from *Fergusonia* sp. galls. Adult representatives of the less common Hymenoptera species were reared from *Fergusonia* sp. galls collected during the previous two years. We sequenced the D2 expansion domain of the 28S rRNA, which ranged from 564 to 593 base pairs long depending on the species. The methods were those described by De Barro *et al.* (2000).

The polymerase chain reaction (PCR) was used to amplify the D2 gene regions for each specimen. Primers for the region followed Campbell *et al.* (1993); D2F 5'-CGTGTGCTTGATAGTGCAGC-3' and D2R 5'-TTGGTCCGTGTTTCAAGACGG-3', or ND2F 5'-AGTACCGTGAGGGAAAGTTG-3', which was used in some reactions as an alternate forward primer which anneals approximately 90 bases down-stream of the D2F binding site. All reaction volumes were 50  $\mu$ l, containing 20 pM of each primer, 200  $\mu$ M each dGTP, dATP, dCTP and dTTP, 1.5–2.5 mM MgCl<sub>2</sub>, 2  $\mu$ l DNA lysate, 1X supplied buff-

Table 1. Gall insects reared during two-year field study.

Site: Galls:	Peregian 366	Morayfield 493	Woodburn 263	All sites 1122
<i>Fergusonina</i> sp.	372	483	420	1275
<i>Eurytoma</i> sp.	300	473	13	786
<i>Coelocyba</i> sp.	276	33	122	431
<i>Neanastatus</i> sp.	65	144	35	244
<i>Cirrospilus</i> sp.	113	19	0	132
<i>Bracon</i> sp.	28	42	47	117
<i>Eupelmus semiputata</i>	4	99	0	103
<i>Chromocryptus</i> sp.	15	50	5	93
<i>Megastigmus</i> sp.	17	35	28	80
<i>Eupelmus</i> ( <i>Eupelmus</i> ) sp.	3	5	2	10
<i>Euderus</i> sp.	3	4	2	9
<i>Poecilocryptus nigromaculatus</i>	0	1	4	5
Total Hymenoptera	824	905	258	2010
% Parasitism	68.90%	65.20%	38.05%	61.19%

er and 2.5 U Taq polymerase (Bresatec, Australia). PCR amplification was done using a Hybaid thermocycler using the following parameters. A pre-cycle denaturation step for 5 min at 94°C, followed by the addition of the Taq polymerase. Then, 35 cycles of 1 min at 94°C, 1 min at 55°C and 1.5 min at 72°C followed by a final post-cycle extension step at 72°C.

The D2 amplicons were purified and prepared for sequencing by electrophoresis in 0.8% TAE agarose gels containing 10 µg ml<sup>-1</sup> ethidium bromide (Sambrook *et al.* 1989). Fragments were excised and transferred to a microfuge tube. The agarose slices were mashed in 30 µl sterile distilled water using a toothpick, then incubated at 50°C for 1 h. Samples were left at room temperature overnight to allow the DNA to elute from the gel. The samples were stored at -20°C until required.

Five microliters of the eluted PCR-amplicons and the appropriate PCR-primers were used for sequencing according to the ABI PRISM Dye Terminator Cycle Sequencing Ready Reaction Kit Manual (PE-Applied BioSystems). Both strands of each fragment were sequenced and reactions were loaded onto an Perkin Elmer, Applied Biosystems Division, Model 377 ABI PRISM Genetic Analyzer. All sequences were deposited in GenBank® (see Table 2).

## RESULTS AND DISCUSSION

Eleven species of Hymenoptera were reared from the *Fergusonina* sp. galls over the two-year sampling period (Table 1). *Eurytoma* sp. was the most common species at Peregian and Morayfield, whereas *Coelocyba* sp. was most common at Woodburn. *Eurytoma* sp. and *Coelocyba* sp. comprised 61% of the 2010 specimens of Hymenoptera reared from the galls over the two-year period. Parasitism of the *Fergusonina* sp. larvae and pupae was high (> 60%) at both Morayfield and Peregian. The pooled percentage parasitism for the three sites over the two year period was 61.2% (Table 1).

We identified the immatures of eight of the eleven species collected in the study by matching their DNA sequences with those of the adult forms (Table 2). The larvae of a ninth species were identified by examining larval exuviae recovered from *Fergusonina* puparia from which parasitoids had emerged. Immatures of the remaining two species were not encountered; their biology was deduced from published information of congeners. All of the immatures analyzed were matched with adult forms except for one hyperparasitoid egg. The D2 sequence from the hyperparasitoid egg was unique and not de-

Table 2. Gall insects identified in study using D2 sequence data.

	Species*	Location	Stage	GenBank accession number	Selection criteria
1	<i>Fergusonina</i> -Male	MORAYFIELD	Adult	AF345569	Primary gall former
2	<i>Fergusonina</i> -Female	WOODBURN	Adult	AF345570	Primary gall former
3	<i>Fergusonina</i>	MORAYFIELD	Larva	AF345571	Primary gall former
4	<i>Eurytoma</i>	MORAYFIELD	Adult	AF345572	Reared from individual that had predated on multiple hosts
5	<i>Eurytoma</i>	PEREGIAN	Adult	AF345573	Reared from individual that had predated on multiple hosts
6	<i>Eurytoma</i>	PEREGIAN	Adult	AF345612	Reared from pupa in chamber with copious masticated gall tissue and black meconium
7	<i>Eurytoma</i>	MORAYFIELD	Larva	AF345574	Larva had fed on multiple hosts, chamber contained ball of <i>Fergusonina</i> remains
8	<i>Eurytoma</i>	PEREGIAN	Larva	AF345575	Larva had fed on multiple hosts, copious amounts of masticated gall tissue present
9	<i>Eurytoma</i>	MORAYFIELD	Larva	AF345613	Larva collected at center of young gall with connections to two other chambers
10	<i>Eurytoma</i>	MORAYFIELD	Larva	AF345606	Larval remains being consumed by <i>Bracon</i> larva
11	<i>Eurytoma</i>	PEREGIAN	Larva	AF345610	Larva with <i>Poecilocryptus</i> larva attached (Specimen 53)
12	<i>Eurytoma</i>	MORAYFIELD	Larva	AF345607	<i>Fergusonina</i> parasitoid in clean gall chamber, attacked by hyper-parasitoid below (Specimen 13)
13	Hyperparasitoid egg	MORAYFIELD	Egg	AF345608	Egg attached to <i>Eurytoma</i> larva (Specimen 12 above)
14	<i>Coelocyba</i>	PEREGIAN	Adult	AF345576	Reared from naked pupa, chamber contained <i>Fergusonina</i> remains
15	<i>Coelocyba</i>	PEREGIAN	Adult	AF345577	Reared from an intact <i>Fergusonina</i> puparium
16	<i>Coelocyba</i>	PEREGIAN	Adult	AF345614	Reared from an intact <i>Fergusonina</i> puparium
17	<i>Coelocyba</i>	PEREGIAN	Adult	AF359455	Reared from an intact <i>Fergusonina</i> puparium
18	<i>Coelocyba</i>	WOODBURN	Larva	AF359454	Larva restricted to single chamber
19	<i>Neanastatus</i>	MORAYFIELD	Adult	AF345580	Reared from <i>Fergusonina</i> gall
20	<i>Neanastatus</i>	PEREGIAN	Adult	AF345582	Reared from <i>Fergusonina</i> gall
21	<i>Neanastatus</i>	MORAYFIELD	Pupa	AF345581	Naked pupa restricted to single chamber
22	<i>Neanastatus</i>	PEREGIAN	Larva	AF345583	Larva collected in single chamber, cradling remains of <i>Fergusonina</i>
23	<i>Neanastatus</i>	MORAYFIELD	Larva	AF345584	Same as above, but from different site
24	<i>Neanastatus</i>	MORAYFIELD	Larva	AF345615	Larva collected from single isolated chamber
25	<i>Cirrospilus</i>	PEREGIAN	Adult	AF345585	Reared from <i>Fergusonina</i> gall
26	<i>Cirrospilus</i>	MORAYFIELD	Adult	AF345586	Reared from <i>Fergusonina</i> gall
27	<i>Cirrospilus</i>	MORAYFIELD	Adult	AF345616	Reared from <i>Fergusonina</i> gall
28	<i>Cirrospilus</i>	PEREGIAN	Larva	AF345604	Collected from isolated chamber with remnants of <i>Fergusonina</i>
29	<i>Cirrospilus</i>	PEREGIAN	Larva	AF345605	Collected from isolated chamber with remnants of <i>Fergusonina</i>
30	<i>Bracon</i>	WOODBURN	Adult	AF345587	Reared from silk cocoon inside <i>Fergusonina</i> gall

Table 2. Continued.

	Species*	Location	Stage	GenBank* accession number	Selection criteria
31	<i>Bracon</i>	MORAYFIELD	Adult	AF345588	Reared from <i>Fergusonina</i> gall
32	<i>Bracon</i>	MORAYFIELD	Larva	AF345589	Larva collected as it was making silk cocoon
33	<i>Bracon</i>	MORAYFIELD	Larva	AF345590	Larva collected as it straddled two chambers, both full of copious masticated gall tissue and <i>Fergusonina</i> remains.
34	<i>Bracon</i>	MORAYFIELD	Larva	AF345617	Larva collected from gall with interconnected chambers, full of masticated gall tissue and <i>Fergusonina</i> remains
35	<i>Eupelmus semiputata</i>	MORAYFIELD	Adult	AF345591	Reared from <i>Fergusonina</i> gall
36	<i>Eupelmus semiputata</i>	MORAYFIELD	Adult	AF345592	Reared from <i>Fergusonina</i> gall
37	<i>Eupelmus semiputata</i>	MORAYFIELD	Adult	AF345618	Reared from <i>Fergusonina</i> gall
38	<i>Chromeurytoma</i>	PEREGIAN	Adult	AF345595	Found in single isolated gall chamber
39	<i>Chromeurytoma</i>	MORAYFIELD	Adult	AF345596	Reared from <i>Fergusonina</i> gall
40	<i>Chromeurytoma</i>	MORAYFIELD	Adult	AF345620	Reared from <i>Fergusonina</i> gall
41	<i>Chromeurytoma</i>	MORAYFIELD	Larva	AF345597	Collected from chamber with <i>Neanastatus</i> pupal remains
42	<i>Chromeurytoma</i>	MORAYFIELD	Larva	AF345598	Collected from chamber with <i>Neanastatus</i> pupal remains
43	<i>Chromeurytoma</i>	MORAYFIELD	Larva	AF345593	Larva collected from intact chamber with wasp pupal remains
44	<i>Megastigmus</i>	MORAYFIELD	Adult	AF345594	Reared from <i>Fergusonina</i> pupal case
45	<i>Megastigmus</i>	WOODBURN	Adult	AF345619	Reared from <i>Fergusonina</i> gall
46	<i>Eupelmus (Eupelmus)</i>	MORAYFIELD	Adult	AF345599	Reared from <i>Fergusonina</i> gall
47	<i>Eupelmus (Eupelmus)</i>	PEREGIAN	Adult	AF345600	Reared from <i>Fergusonina</i> gall
48	<i>Eupelmus (Eupelmus)</i>	PEREGIAN	Adult	AF345621	Reared from <i>Fergusonina</i> gall
49	<i>Euderus</i>	PEREGIAN	Adult	AF345601	Reared from <i>Fergusonina</i> gall
50	<i>Euderus</i>	WOODBURN	Adult	AF345602	Reared from <i>Fergusonina</i> gall
51	<i>Euderus</i>	MORAYFIELD	Egg	AF345609	Egg collected from deflated, dead <i>Poecilcryptus</i> larva
52	<i>Poecilcryptus nigromaculatus</i>	WOODBURN	Adult	AF345603	Adult collected from <i>Fergusonina</i> gall
53	<i>Poecilcryptus nigromaculatus</i>	PEREGIAN	Larva	AF345611	Hyperparasitoid of <i>Eurytoma</i> larva (Specimen 11)

\* No variation was noted in D2 gene sequence data between individuals of each taxon.

tected again. Most species develop in a single intact gall chamber as primary parasitoids of *Fergusonina* sp. The larvae of three species, *Eurytoma* sp., *Bracon* sp. and *Poecilcryptus nigromaculatus* tunneled between gall chambers to feed on multiple hosts. Some authors (eg. Godfray 1994) prefer the term predator to describe this biology. We consider the distinction between predator and parasitoid to be ambiguous and prefer to describe these species as parasitoids feeding on multiple hosts. Several hyperparasitoid species

were identified either by their eggs, that were found attached to parasitoid larvae, or by their larvae that occupied chambers containing the remains of parasitoid larvae or pupae.

### Biology of Associated Hymenoptera

*Eurytoma* sp. (Eurytomidae).—Specimens of *Eurytoma* emerged from galls from all three sites and made up 39.1% of the total number of Hymenoptera reared from the field collections. They were the most numerous gall-associated wasps at

the two Queensland localities, Peregian and Morayfield. Few *Eurytoma* were recovered from galls collected at Woodburn (Table 1). Despite some variation in the coloration of their legs, all specimens appear to belong to a single species. The D2 gene sequences of adults from Peregian and Morayfield were identical (Table 2).

*Eurytoma* is an enormous cosmopolitan genus; Bouček (1988) listed 66 species from Australia and indicated there were many still undescribed. In the absence of revisionary studies on Australian species of *Eurytoma* it was not possible to identify this species. However, it appears to be allied to a distinctive group of Australian *Eurytoma* discussed by Bouček (1988) and characterized mainly by an elongate petiole and relatively long marginal vein. This group includes *E. longipetiolata* Girault and *E. australiensis* Ashmead (Bouček 1988) and after examination of their types by CJB, we believe that *E. carlylei* Girault and *E. herbertensis* Girault probably also belong here. The species of *Eurytoma* reared from *Fergusonina* galls possesses several characters of the group including an elongate female petiole that is longer than the hind coxae and slightly curved, and a laterally compressed gaster that has the combined length of the first three gastral tergites less than their height and shorter than the length of the fourth gastral tergite (Bouček 1988). However, species of the group have the marginal vein 2.5–3× longer than the stigmal vein (Bouček 1988) while the *Eurytoma* sp. from the galls has the marginal vein only about twice the length of the stigmal.

*Eurytoma* sp. larvae had a relatively large head capsule with the mouthparts directed ventrally. The mandibles of mature larvae were bidentate with a strong, acute, apical tooth and an acute subapical tooth about half the length of the apical. Larvae had a series of conspicuous dorsal protuberances on the meso- and metathorax and the first eight abdominal segments. Larvae were only moderately se-

tose with most thoracic and abdominal setae short and inconspicuous. However, each thoracic segment had three pairs of longer setae ventrad of the spiracles.

The larval biology of *Eurytoma* sp. was variable. Commonly larvae fed on multiple *Fergusonina* larvae and possibly the larvae of other gall-associated Hymenoptera. Occasionally individual *Eurytoma* pupae were observed in single intact chambers, having completed their development on only one *Fergusonina* host. Molecular data confirmed that *Eurytoma* developing on single or multiple hosts were the same species.

*Eurytoma* sp. larvae feeding on multiple hosts were found in chambers that were connected by small holes to one or more other chambers. These chambers were typically filled with brown, particulate debris that we interpreted as masticated, but not ingested, gall tissue. In addition, dissociated plates from the dorsal shields of *Fergusonina* larvae were found amongst the brown debris. Frequently several *Eurytoma* larvae completed development in a single gall.

*Eurytoma* is a diverse genus with a wide array of larval biologies ranging from entomophagous to phytophagous species. Many species attack gall formers (Di Giulio 1997) including some that feed on several hosts in multi-chambered galls (Blair 1944, Bouček 1988), which is similar to the species in our study. The larvae of some gall-inhabiting species of *Eurytoma* have been reported to feed on both insect and plant tissue (Varley 1937, Noble 1941, Askew 1961). Although the *Eurytoma* larvae in our study masticated gall tissue, it is not clear if they derived any nutritional benefit from this activity, or if they just mechanically scraped away the tissue to gain access to additional chambers.

All studies on the Hymenoptera associated with *Fergusonina* galls have recorded *Eurytoma* species (Currie 1937, Harris 1982, Taylor *et al.* 1996) but only Currie investigated the larval biology. Unlike our

study, he found that larvae of *Eurytoma* "varirufipes" (an unpublished Girault manuscript name), were inquilines within galls of *Fergusonina nicholsoni* Tonnoir on *Eucalyptus macrorhyncha*, forming separate chambers to those of the fly larvae.

*Coelocyba* sp. (Pteromalidae).—Overall, *Coelocyba* sp. was the second most abundant wasp reared (21.4% of total specimens), but was uncommon at the Morayfield site (Table 1). Bouček (1988) listed nine species of the endemic Australian genus *Coelocyba*, which he noted was composed of two species groups separated on the structure of the dorsellum and propodeum. The species reared from *Fergusonina* sp. galls belongs to the group containing *C. nigrocincta* Ashmead, characterized by the posterior margin of the dorsellum being broadly rounded (Bouček 1988). *Coelocyba* sp. closely resembles *C. nigrocincta* in color pattern, however species in the genus are difficult to recognize and the value of color in distinguishing species is questionable (Bouček 1988). The genus is in need of revision (Bouček 1988) and consequently precise identification of the species reared in the study was not possible.

*Coelocyba* larvae appear almost glabrous, distinguishing them from most larvae encountered during dissections, except those of *Cirrospilus*. *Coelocyba* larvae can be distinguished from *Cirrospilus* larvae by their globular head capsules and ventrally directed mouthparts. In addition, *Coelocyba* larvae have tridentate mandibles with a strong, acute apical tooth; a closely appressed, acute, subapical tooth; and a small basal tooth.

Adults of *Coelocyba* sp. emerged either from naked wasp pupae or from intact *Fergusonina* puparia in approximately equal proportions. The D2 gene sequences of adults reared from both were identical (Table 2). *Coelocyba* that emerged from *Fergusonina* puparia either developed as true endoparasitoids or more probably as ectoparasitoids of the pharate *Fergusonina*

pupa. Chambers that contained parasitized *Fergusonina* puparia closely resembled those with unparasitized puparia. Parasitized puparia were attached to the wall of the chamber by the normal transparent, elastic substance (see Currie 1937: 150). Naked pupae and larvae of *Coelocyba* were always found singly in isolated chambers, along with pale granules of host remains containing *Fergusonina* dorsal plates. In these cases *Coelocyba* developed as a primary ectoparasitoid of the *Fergusonina*. We found no evidence that *Coelocyba* larvae fed on gall tissue. Chambers with *Coelocyba* pupae also contained a patch of dark meconium.

Known species of *Coelocyba* are associated with gall-inducing pteromalids and fergusoninids (Bouček 1988), but their precise larval biologies are unknown. Bouček (1988) and Taylor *et al.* (1996) reported that larvae of *C. nigrocincta* Ashmead had been demonstrated to be inquilines in the galls of *Perilampella hecataeus* (Walker) on *Acacia decurrens* Willdenow, primarily based on work done by Noble (1941). They claimed that the *C. nigrocincta* larva killed the resident gall-inducer and formed its own cell and fed on the gall tissue. However, although Noble (1941) reported that the *C. nigrocincta* larva killed the larva of the gall-inducer, he made no mention of it forming its own chambers, or of it feeding on gall tissue. In our study we found no evidence that *Coelocyba* sp. larvae fed on gall tissue and concluded that they were almost always primary parasitoids of the *Fergusonina* larvae or pupae. This is in agreement with Currie (1937) who briefly noted that the species of *Coelocyba* that he reared from flower bud galls produced by *Fergusonina nicholsoni* on *Eucalyptus macrorhyncha* was a "true parasite" of the fly larvae. Taylor *et al.* (1996) reared *C. nigrocincta* from leaf bud galls on *E. macrorhyncha* but did not investigate its larval biology.

*Neanastatus* sp. (Eupelmidae).—A single species of *Neanastatus* was moderately

common at all three sites (Table 1) and accounted for 12.1% of the total specimens reared. Molecular sequences of adults from Morayfield and Peregian were identical (Table 2). Species of *Neanastatus* are apparently restricted to the Old World (Gibson 1989), but are widely distributed from southern Europe through Africa, and southern Asia to Australia with most species known from the tropics (Bouček 1988). Bouček (1988) lists 21 Australian species, all described by A. A. Girault. Specimens reared from galls of *Fergusonina* sp. on *M. quinquevervia* have the head and most of the meso- and metasoma dark-colored, mostly with metallic green reflections. At least the anterior half of the pronotum and most of the first gastral tergite is yellowish. The hind tibia is mostly black with a narrow, basal, white band. Amongst the Australian species, they most closely resemble *N. flavipronotum* Girault. However the holotype of this species differs in that the lower face surrounding the mouthparts is yellowish. In addition, the pronotum is extensively yellowish with only a narrow posterior dark band.

*Neanastatus* sp. larvae are whitish and fusiform, gradually tapering posteriorly. The larval mandibles are simple, each with a single acute tooth. *Neanastatus* larvae are conspicuously setose, with rows of long lateral setae on the thoracic and abdominal segments, except the first abdominal segment. The thoracic segments have two additional pairs of long setae. The larvae can be distinguished from the setose larvae of *Chromeurytoma* (see below) by the absence of ventrolateral setae on the abdominal segments. *Neanastatus* sp. pupae can be distinguished by a conspicuous tubercle on the dorsal frons.

The available evidence indicates that *Neanastatus* sp. develops as a solitary, primary ectoparasitoid of *Fergusonina* larvae. In all instances, *Neanastatus* larvae, pupae and newly eclosed adults were found singly inside isolated, intact chambers. Ma-

ture larvae were observed resting on their dorsal surfaces and cradling, on their ventral surfaces, small balls of tissue containing *Fergusonina* dorsal plates. There was no indication of *Neanastatus* larvae feeding on gall tissue. *Neanastatus* pupae occupy relatively clean chambers that contain a dark patch of tar-like larval meconium; one or sometimes two shriveled, setose, larval exuvia; and usually the remains of a *Fergusonina* larva indicated by the presence of fragments of the dorsal shield.

Species of *Neanastatus* have been recorded as parasitoids in the galls of cecidomyiid flies, especially those associated with grasses and herbaceous plants (Bouček 1988). According to Gibson (1989) they have either been recorded as primary parasitoids of the fly larvae or as hyperparasitoids through Platygasteridae (Hymenoptera: Platygasteroidea). The biologies of Australian *Neanastatus* are largely unknown, although one species has been reared from galls on *Eremocitrus* (Rutaceae) (Naumann 1991) and CJB has seen a specimen reared from an unidentified gall on *Brachyclitton discolor* F. Mueller (Sterculiaceae). One Australian species, *Neanastatus cinctiventris* Girault, is known to be a parasitoid of the Rice gall-midge, *Orseolia oryzae* (Wood-Mason), throughout southeast Asia. This is the first record of a species of *Neanastatus* attacking a fergusoninid fly. Interestingly, *Neanastatus* has not been reared from several hundred cecidomyiid galls collected from *Melaleuca quinquevervia* (unpublished data).

*Cirrospilus* sp. (Eulophidae).—A single species of *Cirrospilus* was moderately common at Peregian where it was the third most numerous species emerging from galls (Table 1). However, *Cirrospilus* sp. was rare at Morayfield and was not recovered from galls at Woodburn. Molecular sequences of adults from Morayfield and Peregian were identical (Table 2). In total, this species comprised 6.6% of the specimens reared. *Cirrospilus* is a large, morphologically diverse, cosmopolitan genus

with something in the order of 60 described species from Australia (Bouček 1988). In the absence of any revisionary work on Australian *Cirrospilus*, it was not possible to identify the species from *M. quinquevernia* galls. However, it belongs to a group of species that roughly corresponds to A.A. Girault's genus *Gyrolasella* that was synonymised with *Cirrospilus* by Bouček (1988). The color pattern of the species reared from *Fergusonina* sp. galls was similar to that of a number of Australian *Cirrospilus* species that have the body mostly yellowish with metallic green markings on the head and mesosoma and a series of dark brown or black transverse bands on the gaster. The species in our study was similar to the *Cirrospilus* reared from *Fergusonina flavicornis* Malloch galls by Taylor *et al.* (1996, Fig. 14) but had less extensive metallic green on the occiput and the median lobe of the mesoscutum.

Mature larvae of the *Cirrospilus* sp. reared in this study were distinctive and easily distinguished from those of other wasps associated with the galls. The larval head capsule was virtually prognathous, dorsoventrally flattened and with broad, cheek-like, lateral expansions basally. The mandibles were sickle-shaped and unidentate. The head, thorax and abdomen appeared more or less glabrous, without any conspicuous setae. The thorax and abdomen had three and eight low, dorsal protuberances respectively.

The available evidence indicated that *Cirrospilus* sp. developed as a solitary, primary ectoparasitoid of third instar *Fergusonina* larvae. In all instances, *Cirrospilus* larvae and pupae were found singly, inside isolated, intact chambers. Chambers with larvae usually also contained pale granules of host remains and *Fergusonina* dorsal plates. We also observed intact but shrivelled third instar *Fergusonina* larvae together with *Cirrospilus* larvae. We found no evidence of *Cirrospilus* larvae feeding on gall tissue or acting as hyperparasitoids. On first inspection, chambers with

*Cirrospilus* pupae usually appear empty of host remains but contain a thick patch of meconium. On closer inspection, plates from *Fergusonina* dorsal shields were nearly always incorporated into the patch of meconium.

*Cirrospilus* is a biologically diverse genus with species developing as parasitoids or hyperparasitoids, commonly of leafminers, or of other larvae and pupae in concealed situations (Bouček 1988). In Australia, many species are associated with leaf galls, especially on eucalypts (Bouček 1988). Taylor *et al.* (1996) reared a species of *Cirrospilus* from leaf-galls of *Fergusonina flavicornis* on *Eucalyptus camaldulensis*.

*Bracon* sp. (Braconidae).—A single species of *Bracon* was recovered in relatively low numbers from all the sites comprising 5.8 % of the specimens reared, but it was the second most common species at Woodburn (Table 1). Molecular sequences of adults from Woodburn and Peregian were identical (Table 2). *Bracon* is a very large, cosmopolitan genus with many Australian species, most of them undescribed (Austin and Faulds 1989, Quicke and Ingram 1993).

Mature larvae of *Bracon* sp. were distinguished from those of most other wasps associated with the galls, except *Poecilocryptus nigromaculatus* (see below), by their large size. They were also characterized by distinctive labial and maxillary sclerites, and large, heavily sclerotized, unidentate mandibles, which had a series of serrations on their inner margins.

Typically *Bracon* larvae fed indiscriminately on hosts within the galls, entering multiple chambers and consuming a succession of *Fergusonina* larvae and the larvae and pupae of the other wasps associated with the galls. Often two or more *Bracon* larvae completed development within the same gall. Galls occupied by mature *Bracon* larvae usually had several chambers interconnected by relatively large holes. The chambers were generally

packed with brown, particulate debris that we concluded was masticated gall tissue. Chambers also frequently contained dissociated *Fergusonina* dorsal-shield plates. The remains of a *Neamastatus* pupa and a small *Poecilocryptus nigromaculatus* larva were also found within chambers occupied by *Bracon* larvae. On one occasion a *Bracon* larva was directly observed feeding on a *Eurytoma* larva (Table 2). This is the first record of a species of *Bracon* acting as a facultative hyperparasitoid. Other known species of the genus are primary ectoparasitoids (Shaw and Huddleston 1991). Pupation occurred in a relatively loosely woven silk cocoon with brown debris incorporated on its outer surface. The cocoon usually filled two gall chambers and had a mass of dark meconium deposited at one end.

Species of *Bracon* attack diverse hosts but many are parasites of concealed larvae, mostly of Lepidoptera but also Coleoptera and Hymenoptera-Symphyla (Quicke and Ingram 1993). Several species also parasitize Diptera, particularly gall-making larvae (Quicke and Sharkey 1989). This is the second record of a species of *Bracon* from a fergusoninid gall, Taylor *et al.* (1996) having reared *B. fergusoninus* Taylor, Austin and Davies from *Fergusonina flavicornis* leaf-galls on *Eucalyptus camaldulensis*. Currie (1937) also reared an unidentified braconid from *F. nicholsoni* flower-bud galls on *E. macrorhyncha*. He reported that the braconid larvae feed "indiscriminately on gall tissues and fly larvae" and it seems likely that their biology is similar to the *Bracon* sp. in our study. However, although we confirm that the *Bracon* larvae masticate a considerable amount of gall tissue, evidenced by copious amounts of brown debris, it is unclear whether they derive nutrition from this activity or just mechanically scrape away the tissue to gain access to additional chambers. Larval phytophagy is very rare in the Braconidae and has never been con-

firmed for the subfamily Braconinae (Taylor *et al.* 1996).

*Eupelmus (Macroneura) semiputata* (Girault) (Eupelmidae).—*Eupelmus semiputata* was moderately common from galls at Morayfield but rare at Peregian and not collected from Woodburn (Table 1). Of the 103 reared in the study (5.1% of total specimens reared), 74 came from galls collected in 1998. During 1999 only ten *E. semiputata* were reared. We did not encounter any larvae in our dissections. Molecular sequences of adults from Morayfield and Peregian were identical (Table 2). There is only a single described Australian species of *Eupelmus (Macroneura)* although Bouček (1988) indicated a second, presumably undescribed, Australian species. The specimens reared in this study appeared to match the holotype of *E. semiputata*.

Species of *Eupelmus (Macroneura)* are cosmopolitan, primary or secondary parasites of a wide variety of insect hosts in concealed locations, such as within galls, grass stems, or cocoons. Some species are highly polyphagous, sometimes attacking hosts from several different orders (Gibson 1990). A. A. Girault, in his unpublished manuscript (see Dahms 1978), recorded *E. semiputata* emerging from cecidomyiid galls on Pitted bluegrass, *Bothriochloa decipiens* (Häckel) C. E. Hubbard (as *Andropogon pertusus* (L.) Willdenow). Several other species of chalcidoids were also reared from these galls. CJB has also reared specimens of *E. semiputata* from final instar larvae of *Aspidomorpha densta* (Fabricius) (Coleoptera: Chrysomelidae), most probably as a hyperparasitoid through an unidentified tachinid. This is the first record of *E. semiputata* emerging from galls of Fergusoninidae.

*Chromeurytoma* sp. (Pteromalidae).—Specimens of *Chromeurytoma* were reared in low numbers from all three sites (Table 1) and comprised 4.6% of the total specimens reared. Molecular sequences of the D2 gene were obtained only from adults and larvae from Morayfield (Table 2) but,

based on morphology, adults from all three sites appear to be the one species. There are fourteen described species of *Chromeurytoma*, all from Australia. The species reared in our study could not be assigned to one of the described species.

The larvae of *Chromeurytoma* sp. were normally active and conspicuously setose. They were relatively elongate, gradually tapering posteriorly. The body also tapered anteriorly to a relatively small head capsule. The mandibles of mature larvae were thin with a single, strong, acute tooth. The heavily setose bodies of *Chromeurytoma* larvae distinguished them from most other larvae within the galls. *Neanastatus* larvae were superficially similar but less setose, lacking the elongate ventrolateral setae found on the abdominal segments of *Chromeurytoma* larvae. In addition, *Chromeurytoma* larvae had lateral setae on the first abdominal segment (absent in *Neanastatus*) and had the most posterior pair of setae on the head capsule more widely separated. The bases of the posterior setae on the head capsule were separated by more than twice the length of a seta in *Chromeurytoma* larvae, but only by about the length of a seta in *Neanastatus* larvae. *Chromeurytoma* larvae usually had a conspicuous dorsal hump between the first and second abdominal segments and a series of thin, transverse, sclerotized, intersegmental bands between the thoracic and first seven abdominal segments.

*Chromeurytoma* larvae were most commonly solitary hyperparasitoids through other Hymenoptera within the galls, feeding on their mature larvae or pupae. *Chromeurytoma* larvae or pupae were recovered from chambers containing the remains of *Neanastatus* and *Eurytoma* pupae and from chambers containing moribund *Bracon* larvae or their head capsules. On two occasions, *Chromeurytoma* larvae occupied isolated chambers containing the remains of lightly sclerotized *Fergusonina* larvae, and possibly developed as primary ectoparasitoids of the fly.

Species of *Chromeurytoma* have been reared from unidentified galls on species of *Eucalyptus* and *Acacia* (Bouček 1988). This study is the first to record *Chromeurytoma* emerging from galls of Fergusoninidae and the first to document the larval biology of a member of the genus.

*Megastigmus* sp. (Torymidae).—Specimens of *Megastigmus* were reared in low numbers from all three sites (Table 1) and comprised 4.0% of the total specimens. Of the 80 adults reared during the entire study, 55 emerged from galls collected in 1997. Molecular sequences of adults from Morayfield and Woodburn were identical (Table 2). *Megastigmus* is a large genus distributed throughout most of the world, except the Neotropics. It is particularly speciose in Australia with 47 described species (Bouček 1988). In the absence of any revisionary studies on the genus and given that species often display considerable variation in size, color and sculpture (Bouček 1988), no attempt was made to identify the species reared in our study.

Larvae of *Megastigmus* sp. were not encountered in our original dissections of galls from which specimens were sequenced. However, examination of larval exuviae recovered from *Fergusonina* puparia from which *Megastigmus* sp. adults had emerged, enabled us to identify larvae of *Megastigmus* sp. in subsequent gall dissections. Larvae resembled those of *Eurytoma* sp., but mature *Megastigmus* larvae could be distinguished from those of *Eurytoma* sp. and all other gall-associated wasps by their distinctive mandibles. Each mandible was 4-dentate, with a large, acute, apical tooth and three small teeth evenly spaced along its inner cutting edge. They closely resemble the larval mandibles of *Megastigmus dorsalis* (Fabricius) figured by Askew (1966).

The larval biology of *Megastigmus* sp. was variable. Most commonly, adults emerged from intact *Fergusonina* puparia found within isolated gall chambers. Each parasitized puparium contained the exu-

vium of the final instar *Megastigmus* larva and meconium in the form of numerous black, discrete pellets. Presumably, *Megastigmus* sp. developed as a primary parasitoid, either as an endoparasitoid or ectoparasitoid of the pharate *Fergusonina* pupa. We found no evidence that *Megastigmus* developed as a hyperparasitoid within puparia. Less commonly, *Megastigmus* appeared to develop as a solitary ectoparasitoid of third instar *Fergusonina*. *Megastigmus* larvae and naked pupae were found within isolated gall chambers that contained pale, granulate host remains including dissociated *Fergusonina* dorsal shield plates. In these cases the voided larval meconium consisted of a thick mass instead of discrete pellets. In addition, *Megastigmus* sp. also developed as a hyperparasitoid through *Bracon* sp. On several occasions, *Megastigmus* larvae, pupae or pharate adults were found within cocoons with the remains of *Bracon* prepupae, pupae or pharate adults.

*Megastigmus* is a biologically diverse genus with species having larval biologies ranging from obligate plant feeders to obligate parasitoids (Bouček 1988). Currie (1937) reared two species of *Megastigmus*, *M. quinquesetae* (Girault) and an unidentified species, from *Fergusonina nicholsoni* flower-galls on *Eucalyptus macrorhyncha*. He reported that the larvae of both species were inquiline within the galls, forming their own separate chambers and presumably feeding on gall tissue. In contrast, the *Megastigmus* in our study appears to be entirely entomophagous. Taylor *et al.* (1996) also reared two species of *Megastigmus* from *Fergusonina flavicornis* leaf-galls on *E. camaldulensis* but they did not investigate their larval biologies.

*Eupelmus* (*Eupelmus*) sp. (Eupelmidae).—Specimens of *Eupelmus* were recovered in very low numbers from all three sites and accounted for 0.5% of total specimens reared (Table 1). They appeared to belong to a single species and the molecular sequences of adults from Morayfield

and Peregian were identical (Table 2). *Eupelmus* sp. larvae were not sequenced as none were encountered during dissections. A single adult female was found in an isolated gall chamber together with a lightly sclerotized, collapsed *Fergusonina* prepupa. The pupal exuvium of the wasp was also present in the chamber. The precise larval biology of *Eupelmus* sp. is unknown although it is clearly a solitary primary parasitoid or hyperparasitoid. There are many species of *Eupelmus* (*Eupelmus*) found throughout the world; they are parasitic, or rarely 'predatory', on a wide variety of hosts (Bouček 1988). Harris (1982) also reported a species of *Eupelmus* emerging from *Fergusonina syzygii* Harris galls on *Syzygium cumini* (L.) (Myrtaceae) in India.

*Euderus* sp. (Eulophidae).—Specimens of *Euderus* were recovered in very small numbers from all three sites and accounted for 0.5% of total specimens reared (Table 1). They appeared to represent a single species and the molecular sequences of single adults from Peregian and Woodburn were identical. *Euderus* larvae and pupae were not encountered during dissections. However, the D2 gene sequence of a single egg matched that of the adult *Euderus* (Table 2). The egg was attached to a moribund *Pocilocryptus nigromaculatus* (see below) larva that had been feeding on a *Fergusonina* puparium. Evidently *Euderus* sp. acts a hyperparasitoid within the galls, which might explain its low relative abundance. *Euderus* is a large cosmopolitan genus with species attacking larval Lepidoptera and Coleoptera (Bouček 1988). Species are also known to be hyperparasitic, attacking Braconidae (Bouček 1988). Taylor *et al.* (1996) also reared a species of *Euderus* in low numbers from *Fergusonina flavicornis* leaf-galls. They suggested that its larvae might be hyperparasitic on *Bracon ferrugineus* within the galls.

*Pocilocryptus nigromaculatus* Cameron (Ichneumonidae).—*Pocilocryptus nigroma-*

*culatus* was the rarest gall-associated wasp species at 0.3% of the total specimens reared, with only one and four specimens recovered from Morayfield and Woodburn respectively (Table 1). The specimens appeared to be *P. nigromaculatus*, although they differed slightly in coloration, lacking the black markings on the second gastral tergite normally found in this species (Gauld and Holloway 1986).

Mature *P. nigromaculatus* larvae were distinguished from most gall-associated wasp larvae, except those of *Bracon* sp., by their large size. They could be distinguished from *Bracon* larvae by their very large, heavily sclerotized, bidentate mandibles and by a large sclerotized plate on the postlabium (see Short 1978).

Only a single *P. nigromaculatus* larva and a single pupa were recovered from dissections of galls from Woodburn, Morayfield and Peregrin but several larvae and prepupae were found in additional dissections of galls from Bracken Ridge and Coolum (QLD). Only a single mature larva, prepupa or pupa of *P. nigromaculatus* was observed per gall. Each gall had its internal structure highly modified, with most chambers breached and interconnected by relatively large holes. The chambers were generally packed with brown, particulate debris that we concluded was masticated gall tissue. However, various chambers also contained dissociated *Fergusonina* dorsal-shield plates, empty *Fergusonina* puparia rent with large, ragged holes, the remains of *Bracon* pupae and pharate adults, and *Bracon* larval mandibles. *Poecilocryptus nigromaculatus* pupated within the gall in a relatively large central cavity, incorporating several chambers, presumably excavated by the larva. Pupation occurred inside a brown, moderately densely woven cocoon with brown debris incorporated on its outer surface.

*Poecilocryptus* (Subfamily Labeninae) is an endemic Australian genus associated with a variety of galls on trees of the gen-

era *Eucalyptus*, *Acacia*, *Banksia* (Gauld and Holloway 1986, Taylor *et al.* 1996) and now *Melaleuca*. *Poecilocryptus nigromaculatus* has been reared from anthribid weevil galls on *Acacia floribunda* (Ventenat) Willdenow (= *A. longifolia*), eriococcid galls on *Eucalyptus* (Gauld and Holloway 1986), and pteromalid galls on *Acacia* (Noble 1941) including those of *Trichilogaster acaciaelongifoliae* (Froggatt) on *A. floribunda*, and *Perilampella hecataeus* (Walker) on *A. decurrens* Willdenow. *Poecilocryptus nigromaculatus* has also been recorded from galls of Fergusoninidae, Taylor *et al.* (1996) rearing it and *P. galliphagus* Gauld and Holloway from *Fergusonina flavicornis* Malloch galls on *Eucalyptus camaldulensis*.

There are conflicting reports about the biology of *Poecilocryptus*. We concluded that *Poecilocryptus nigromaculatus* larvae fed on many hosts within each *Fergusonina* gall, using their large mandibles to chew through gall tissue and enter multiple chambers. They appeared to consume the inhabitants of each chamber regardless of its identity. Noble (1941) considered that *P. nigromaculatus* was parasitic upon the larvae of a moth that lived as an inquiline within the multichambered galls of *Trichilogaster acaciaelongifoliae*. He had no direct evidence of this host association but specifically noted an adult *P. nigromaculatus* occupying a gall that had much of its interior hollowed out by what he assumed was a moth larva. However, his description bears a striking similarity to the situation we observed in the *Fergusonina* galls and we suggest that *P. nigromaculatus* is probably also a generalist parasitoid within *Trichilogaster* galls.

Members of the tribe Poecilocryptini all appear to oviposit within nutritious plant tissue (Gauld and Holloway 1986). The enormous mandibles of their larvae led Short (1978) to speculate that they may be, at least in part, phytophagous. According to Quicke (1997) partial phytophagy has been confirmed for a species of *Poecilocryptus* living within coccoid-induced

Table 3. Summary of the biologies of Hymenoptera associated with galls of *Fergusonina* sp. *Eupelmus semiputata* not included due to lack of information. ? = Some evidence but not confirmed.

Species	Primary Endoparasitoid	Primary Ectoparasitoid	Hyperparasitoid	Single hosts	Multiple hosts
<i>Eurytoma</i> sp.	?	X		X	X
<i>Coelocyba</i> sp.		X		X	
<i>Neanastatus</i> sp.		X		X	
<i>Cirrospilus</i> sp.		X		X	
<i>Bracon</i> sp.		X	X	rarely	X
<i>Chromeurytoma</i> sp.		?	X	X	
<i>Megastigmus</i> sp.	?	X	X	X	
<i>Eupelmus</i> ( <i>Eupelmus</i> ) sp.				X	
<i>Euderus</i> sp.			X		
<i>Poecilocryptus nigromaculatus</i>		X	X		X

galls. We confirmed that *Poecilocryptus* larvae masticate a considerable amount of *Melaleuca* gall tissue, evidenced by copious amounts of brown debris. However, it is unclear whether they derived nutrition from the plant tissue or just mechanically eroded the chamber walls to gain access to their contents.

### CONCLUSION

Of the eleven species of Hymenoptera associated with the *Fergusonina* sp. gall, we were able to observe and describe the biology of nine of the species (Table 3). Seven commonly or exclusively fed directly upon the *Fergusonina* larvae and or pupae with most species developing on a single host. However, three of the seven usually fed on multiple hosts. These species have specialized biologies, which enable them to chew through plant tissues to access gall inhabitants. On the available evidence, the remaining two species appeared to be hyperparasitoids. We do not know which of the eleven species are gall specific, but did find it interesting that none of these species were reared from other galls on *M. quinquenervia* formed by Cecidomyiidae or Homoptera (unpublished data). None of the Hymenoptera in this study could be described as inquiline. The term inquiline is defined by Torre-Bueno (1989) as a commensal that lives in a very close spatial relationship with its

host, in its shelter, not feeding on it, but frequently destroying it. We did occasionally observe species of Lepidoptera acting as inquilines, including one species, *Holocola* sp. (Tortricidae), which is known to feed on young leaf and flower buds of *M. quinquenervia* (unpublished data).

We found the D2 molecular method to be robust for characterizing all life stages including eggs and small larvae. Further, the D2 gene sequence was consistent for each species and between adults and immatures. In the dissections we encountered the immature forms of eight out of eleven species, which were matched with the adult forms. The molecular technology provides many advantages in the study of cryptic immature insects. The amount of time and effort required to identify immatures is greatly reduced because rearing to the adult stage is not needed. The biology of the immatures can be observed *in vivo* and matched with adults without speculation or comparison to known biologies of related species. A greater number of gall-inhabiting insects are likely to be discovered using this technique as compared to other techniques. Removal of the gall from the plant and holding it for insect emergence subjects the inhabitants to changes in plant turgor, humidity and temperature. All of these factors could be critical to the survival of the immatures. Sleeving the gall for collection of emerging

insects may be biased against late arrivals such as hyperparasitoids.

Gene sequences are quantitative and can be compared to sequences collected later in the study or by other researchers. By posting the sequence on GenBank® other researchers may in turn match the identity of their insects. Sequence data serves as an interim identity for the insect species until they are described. Field studies and biological control programs in particular should submit vouchers not only of the insect specimens but also of the gene sequences as well. Later revisions of genera could include, where possible, the molecular data from a wide array of biological studies. In this way a greater number of specimens could be identified simultaneously. Our understanding of the biology and distribution of insect species would be greatly enhanced.

In biological control programs directed against weeds, agents must reach high population levels in order to control their host. Development of high population levels in the region of introduction is promoted initially by an almost unlimited food supply and by release from the agent's natural enemies (Harley and Forno 1992). *Fergusonina* sp. is likely to be introduced to Florida, USA, where it will find an abundance of suitable *M. quinque-nervea* plant buds which it needs to form galls (Goolsby *et al.* 2000a, Van *et al.* 2000). In its region of origin *Fergusonina* sp. is heavily attacked by natural enemies, including eight primary parasitoids. One would predict that fewer parasitoid species would attack *Fergusonina* sp. in Florida, and that they would be less co-adapted than those in Australia. Fergusoninidae are not represented in the New World, so the association with this family of gall-making flies would be novel for the indigenous parasitoids. In the absence of its co-evolved natural enemies, *Fergusonina* sp. could reach much higher populations levels, potentially having an impact on *M. quinque-nervea*. We hope that our study

provides the basis for future comparisons of natural enemies of *Fergusonina* sp. in both its native and adventitious range. This research would further our ability to predict the impact of indigenous parasitoids on introduced biological control agents.

#### ACKNOWLEDGEMENTS

The authors wish to thank John LaSalle, Mike Rose, and the referees for their helpful comments in preparation of the manuscript; Diana Hartley and Leslie McKenzie for molecular sequencing; Matthew Purcell, Ted Center and Gary Buckingham for collaborative insights; Jeff Wright for photographs of the galls. Research funding was provided by South Florida Water Management District, Army Corps of Engineers, Florida Department of the Environment, and USDA-ARS-Office of International Research Programs.

#### LITERATURE CITED

- Askew, R. R. 1961. On the biology of the inhabitants of oak gall of Cynipidae (Hymenoptera) in Britain. *Transactions of the Society for British Entomology* 14: 237–268.
- Askew, R. R. 1966. Observations on the British species of *Megastigmus* Dalman (Hym., Torymidae) which inhabit cynipid oak galls. *Entomologist* 99: 124–128.
- Austin, A. D. and W. Faulds. 1989. Two new Australian species of *Bracon* F. (Hymenoptera: Braconidae) parasitic on *Phylactophaga* spp. (Hymenoptera: Pergidae). *Journal of Australian Entomological Society* 28: 207–213.
- Babcock, C. S. and J. M. Heraty. 2000. Molecular markers distinguishing *Encarsia formosa* and *Encarsia luteola* (Hymenoptera: Aphelinidae). *Annals of the Entomological Society of America* 93: 738–744.
- Blair, K. G. 1944. A note on the economy of the rose bedeguar gall, *Rhodites rosae* L. *Proceedings and Transactions of the South London Entomological and Natural History Society* 1943–44: 54–59.
- Bouček, Z. 1988. *Australasian Chalcidoidea (Hymenoptera) A Biosystematic Revision of Genera of Fourteen Families, with Reclassification of Species*. CAB International, Wallingford, UK, 832 pp.
- Campbell, B., J. D. Steffen-Cambell and J. H. Werren. 1993. Phylogeny of the *Nasonia* species complex (Hymenoptera: Pteromalidae) inferred from an internal transcribed spacer ITS2 and 28S rDNA sequences. *Insect Molecular Biology* 2: 225–237.
- Currie, G. A. 1937. Galls on eucalyptus trees, a new type of association between flies and nematodes.

- Proceedings of the Linnaean Society of New South Wales* 62: 147–175.
- Dahms, E. C. 1978. A checklist of the types of Australian Hymenoptera described by Alexandre Arsené Girault: I. Introduction, acknowledgements, biography, bibliography, and localities. *Memoirs of the Queensland Museum* 19: 127–190.
- De Barro, P. J., F. Driver, I. D. Naumann, G. M. Clarke and J. Curran. 2000. Descriptions of three species of *Eretmocerus* Haldemann (Hymenoptera: Aphelinidae) parasitising *Bemisia tabaci* (Gennadius) (Hemiptera: Aleyrodidae) and *Trialeurodes vaporariorum* (Westwood) (Hemiptera: Aleyrodidae) in Australia based on morphological and molecular data. *Australian Journal of Entomology* 39: 259–269.
- Di Giulio, J. 1997. Chapter 12. Eurytomidae. In: Gibson, G.A.P., Huber, J.T. and Woolley, J.B. 1997. *Annotated Keys to the Genera of Nearctic Chalcidoidea* (Hymenoptera). National Research Council of Canada Monograph Publishing Program, Ottawa, 794 pp.
- Ferrar, P. 1987. *A guide to the breeding habits and immature stages of Diptera Cyclorrhapha. Part 1.* E. J. Brill/Scandinavian Science Press, Vinderup, Denmark, 478 pp.
- Gauld, I. D., and G. A. Holloway. 1986. Australian ichneumonoids of the tribes Labenini and Poecilocryptini. *Bulletin of the British Museum of Natural History* 53: 107–149.
- Giblin-Davis, R. 2000. Entomophilic Nematode Models for Studying Biodiversity and Cospeciation. In Chen, Z.X., Chen, S.Y. and Dickson, D.W. (eds). *Nematology, Advances and Perspectives. Volume II. Nematode management and utilization.* Springer-Verlag and Tsinghua University Press (TUP, China) (In Press)
- Gibson, G. A. P. 1989. Phylogeny and classification of Eupelmidae, with revision of the world genera of Calosotinae and Metapelmatinae (Hymenoptera: Chalcidoidea). *Memoirs of the Entomological Society of Canada* 149: 1–121.
- Gibson, G. A. P. 1990. Revision of the genus *Macroneura* Walker in America north of Mexico (Hymenoptera: Eupelmidae). *Canadian Entomologist* 122: 837–873.
- Godfray, H. C. J. 1994. *Parasitoids: Behavioral and Evolutionary Ecology.* Princeton University Press, Princeton. 473 pp.
- Goolsby, J. A., J. Makinson and M. Purcell. 2000a. Seasonal phenology of the gall-making fly *Fergusonina* sp. (Diptera: Fergusoninidae) and its implications for biological control of *Melaleuca quinquenervia*. *Australian Journal of Entomology* 39: 336–343.
- Goolsby, J. A., P. W. Tipping, T. D. Center and F. Driver. 2000b. Evidence of a new *Cyrtobagous* species (Coleoptera: Curculionidae) on *Salvinia* Baker in Florida. *Southwestern Entomologist* 25: 299–301.
- Harley, K. L. S and I. W. Forno. 1992. *Biological Control of Weeds, a handbook for practitioners and students.* Inkata Press, Sydney, 74 pp.
- Harris, K. M. 1982. First record of Fergusoninidae (Diptera: Schizophora) outside Australia: a new species of *Fergusonina* on *Syzygium* in India. *Systematic Entomology* 7: 211–216.
- Manongi, F. S. and J. H. Hoffman. 1995. The incidence of parasitism in *Trichilogaster acaciaelongifoliae* (Frogatt) (Hymenoptera: Pteromalidae), a gall-forming biological control agent of *Acacia longifolia* (Andr.) Willd. (Fabaceae) in South Africa. *African Entomology* 3: 147–151.
- Naumann, I. D. 1991. Hymenoptera. pp. 916–1000. In, *The Insects of Australia.* Vol. II, CSIRO Entomology, Melbourne University Press.
- Noble, N. S. 1941. *Trichilogaster maideni* (Frogatt) (Hymenoptera: Chalcidoidea), a wasp causing galls on *Acacia implexa* Benth., and *A. maideni* F.v.M. *Proceedings of the Linnaean Society of New South Wales* 161: 179–200.
- Quicke, D. L. J. 1997. *Parasitic Wasps.* Chapman & Hall, London, 470 pp.
- Quicke, D. L. J., and S. N. Ingram. 1993. Braconine Wasps of Australia. *Memoirs of the Queensland Museum* 33: 299–336.
- Quicke, D. L. J. and M. J. Sharkey. 1989. A key and notes on the genera of Braconinae (Hymenoptera: Braconidae) from America north of Mexico with descriptions of two new genera and three new species. *Canadian Entomologist* 121: 337–361.
- Sambrook J., E. F. Fritsch and T. Maniatis. 1989. *Molecular Cloning: A Laboratory manual.* 2<sup>nd</sup> ed. Cold Spring Harbour Laboratory Press, Cold Spring Harbour, NY.
- Shaw, M. R. and T. Huddleston. 1991. Classification and biology of braconid wasps (Hymenoptera: Braconidae). *Handbooks for the Identification of British Insects* 7 (11): 1–126.
- Short, J. R. T. (1978) The final larval instars of the Ichneumonidae. *Memoirs of the American Entomological Institute* 25: 1–508.
- Shorthouse, J. D., I. F. Mackay and T. J. Zmijewskij. 1990. Role of parasitoids associated with galls induced by *Hemada nubilipennis* (Hymenoptera: Pteromalidae) on Lowbush Blueberry (*Vaccinium corymbosum*). *Environmental Entomology* 19: 911–915.
- Taylor, G. S., A. D. Austin and K. A. Davies. 1996. Biology of the eucalypt gall-forming fly, *Fergusonina flavicornis* Malloch (Diptera: Fergusoninidae) and its associated Hymenopterans in South Australia, with a description of a new species of *Bracon* (Hymenoptera: Braconidae). *Transactions of the Entomological Society of South Australia* 120: 131–146.
- Filmon, K. J., B. N. Dantorth, W. H. Day and M. P.

- Hoffman. 2000. Determining parasitoid species composition in a host population: a molecular approach. *Annals of the Entomological Society of America* 93: 640–647.
- Torre-Bueno, J. R. 1989. *The Torre-Bueno glossary of entomology / compiled by Stephen W. Nichols; including supplement A by George S. Tulloch*. New York Entomological Society, New York USA, 840 pp.
- Turner, C. E., T. D. Center, D. W. Burrows and G. R. Buckingham. 1998. Ecology and management of *Melaleuca quinquenervia*, an invader of wetlands in Florida, USA. *Wetlands Ecology and Management* 5: 165–178.
- Van, T. K., M. B. Rayachhetry and T. D. Center. 2000. Estimating above-ground biomass of *Melaleuca quinquenervia* in Florida, USA. *Journal of Aquatic Plant Management* 38: 62–67.
- Varley, G. C. 1937. Description of eggs and larvae of four species of chalcidoid Hymenoptera parasitic on the knapweed gall-fly. *Proceedings of the Royal Entomological Society of London* 6: 122–130.

## Taxonomy and Ecology of Costa Rican *Euplectrus* (Hymenoptera: Eulophidae), Parasitoids of Caterpillars (Lepidoptera)

MICHAEL E. SCHAUFF AND DANIEL H. JANZEN

(MES) Systematic Entomology Laboratory, Agricultural Research Service, Plant Sciences Institute, c/o National Museum of Natural History, Washington, D.C. 20560-0168, USA (e-mail: mschauff@sel.barc.usda.gov); (DHJ) Department of Biology, University of Pennsylvania, Philadelphia, PA 19104, USA (e-mail: djanzen@sas.upenn.edu)

---

*Abstract.*—The species of parasitic wasps in the genus *Euplectrus* (Hymenoptera: Eulophidae) known from Costa Rica are reviewed, and their ecology is briefly summarized from a long-term on-going inventory of caterpillars (Lepidoptera) and their parasitoids in the Area de Conservación Guanacaste in northwestern Costa Rica. Twenty species are reported, of which 17 are new species described by Schauff: *Euplectrus anae*, *E. carlowae*, *E. edithae*, *E. floryae*, *E. hansonii*, *E. ireneae*, *E. ivonae*, *E. josei*, *E. magdae*, *E. mariae*, *E. orias*, *E. rojasi*, *E. romieci*, *E. valverdei*, *E. walteri*, *E. xiomarae* and *E. zamorai*. An illustrated key and photographs of larvae supplement the descriptions.

---

Members of the genus *Euplectrus* (Hymenoptera: Eulophidae) are parasitoids on many species of caterpillars that live and feed exposed on the foliage of their food plants (Ferriere 1941, Bouček 1988). Some species have been used in biological control (Puttler *et al.* 1980). The wasps' ability to arrest host caterpillar molting by injecting a chemical arrestant through the ovipositor prior to egg laying also has potential as a tool in pest control (Coudron and Puttler 1988, Coudron and Brandt 1996). In spite of its potential value to agriculture and intriguing natural history, *Euplectrus* has not been studied in any comprehensive manner. This is the first in a series of studies anticipated on the systematics of the New World species of *Euplectrus*. It is intended to alert field biologists about their distinctive ecology.

Very little is known of the systematics of the Central American species of this genus, and almost nothing has been published on their ecology/ life history. An unpublished Ph.D. thesis discussed the New World species and contains records of several Central American species (Gon-

zalez 1985). But, since this thesis has remained unpublished, these records remain unavailable. DeSantis (1967), DeSantis (1979), and DeSantis (1980), DeSantis and Fidalgo (1994) cataloged the 21 species that have been described from Central and South America. Only three species were recorded from Costa Rica (*E. cosmtockii*, *E. furnius*, and *E. solitarius*) and we describe 17 new ones in the paper.

As is often the case in chalcidoid wasps, host records for *Euplectrus* have been scattered and are of questionable accuracy. However, extensive rearing of Lepidoptera larvae for the past two decades (<http://janzen.sas.upenn.edu>) as a caterpillar inventory of the biodiversity of the Area de Conservación Guanacaste (ACG) in northwestern Costa Rica (<http://www.acguanacaste.ac.cr> and Janzen 2000) has generated more than 250 *Euplectrus* rearings, along with those of other parasitoids (e.g., Gauld *et al.* 1992, Janzen 1993, Gauld and Janzen 1994, Sharkey and Janzen 1995, Dangerfield *et al.* 1996, Janzen, D. H. and I. D. Gauld 1997, Zitani *et al.* 1997, Janzen *et al.* 1998). In addition, P. Hanson

of the Universidad de Costa Rica and I. D. Gauld of The Natural History Museum have extensively malaise trapped the parasitoid fauna in Costa Rica, and this material is considered here as well. As a result of these efforts, we are now able to report in a detailed manner on the composition of this genus over a large area of many habitats. Although this study expands the number of species known from Costa Rica by about 500%, we feel that many more species remain to be discovered. *Euplectrus* appear in Malaise traps with very low frequency, so that their presence will have to be detected largely through rearing programs.

Among Eulophidae, the tribe Euplectrini is one of the most easily identifiable since all species share the greatly elongated hind tibial spur(s) (Fig. 89) that have been the defining synapomorphy for the group since the last century (Bouček 1988, Wijesekara and Schauff 1994). Species of *Euplectrus* can be differentiated from other genera in the Euplectrini by having a simple median carina on the propodeum, lacking submarginal grooves on the scutellum, and having only 2–3 pairs of setae on the mesoscutal midlobe and spinning a cocoon as illustrated in Figs. 1–9. A key to New World genera was published by Wijesekara and Schauff (1997).

*Euplectrus* (Fig. 4) is also unique among Eulophidae in that the larvae live externally on the host and spin a cocoon in which to pupate. Equally unique, the cocoon silk is produced from the anus by modified malpighian tubules (Ferrière 1941). The eggs are laid externally in groups on the host caterpillar. The larvae feed on hemolymph through the cuticle and mature while attached to the back of the host by their mouthparts (Figs. 1, 5, 6, 8). When ready to pupate, the larvae of some species move to the underside of the caterpillar cadaver (Figs 2, 3, 9), while others spin a ruff of cocoons around the cadaver.

Below, we describe the species of *Eu-*

*plectrus* (the senior author is the taxonomic author of these species), and give an account of the natural history for those on which we have been able to accumulate data.

Abbreviations of museums are as follows: U.S. National Museum of Natural History, Washington, D. C. (USNM); The Natural History Museum, London (BMNH); Instituto Nacional de Biodiversidad (INBIO), Costa Rica; Canadian National Collection, Ottawa (CNC).

High resolution digital copies of the original photographs for Figures 1–9, all taken in the Area de Conservación Guanacaste, are available at Janzen and Hallwachs (2000).

*Morphology.*—One of the distinctive features of species of *Euplectrus* is the arrangement of small and enlarged setae on the head (Fig. 23). There are up to six pairs of thickened and elongated setae on the upper part of the head. There are two pairs postero-laterally along the occipital carina (S1 and S2). There is a pair between the posterior ocelli (S3) and a pair laterad of the anterior ocellus (S4). S5 lies on the vertex forward of S4 and between the top of the scrobes and the eye. S6 is located near the edge of the eye about 1/2 way down the orbit. In all the species examined to date, S1, S2, S3, and S6 are always present. S4 and S5 may be either reduced or absent.

In addition to the enlarged setae, there are also several smaller setae, some of which occur in pairs (Fig. 23). There is generally a row of setae behind the eye and below the occipital carina (sr1). There is a pair of small setae (ss1) near the occipital carina between S1 and S2. Between and slightly behind the posterior ocelli are one or two pairs of small setae (ss2) that are occasionally absent. Laterad of S4 there is a single small seta (ss3) and laterad and below S6 there is an irregular line of setae (sr2) that usually extends to the bottom of the eye.

The antenna has four funicular seg-



Figs. 1-3. Lepidopteran larvae attacked by *Euplectrus*. 1, A normal size clutch of *E. floryae* larvae feeding on body fluids of a pen-penultimate (third) instar of *Enyo ocypte* (Sphingidae). All species of *Euplectrus* for which the larvae are known except *E. walteri* (Figs. 4-7) display this general appearance on their host caterpillars (e.g., Fig 8); 2, The mummified cadaver of an ultimate (fifth) instar *Paectes lunodes* (Noctuidae) caterpillar after the larvae of *E. joesi* have terminated their feeding on it and spun cocoons between the cadaver and the leaf, firmly silking/gluing the cadaver to the cocoons (see Fig. 3). Fourteen spheroidal meconial pellets from 14 wasp larvae surround the cadaver. This is the pupation method used by all species of *Euplectrus* known except for *E. walteri* (Figs. 4-7); 3, The side-by-side and often head-to-toe cocoons/pupae of 16 *E. joesi* after the mummified cadaver of their host caterpillar (and see Fig. 2) has been stripped away. When exposed in this manner, the pupae often die of apparent desiccation unless placed in a high-humidity container.

ments (F1-F4) followed by a club or clava (Fig. 25). The female scape is cylindrical and 4-6× as long as wide. The male scape shows great variation from cylindrical (as

in females) to greatly enlarged and balloon-like (Fig. 50). All male scapes possess groups of sensillae which appear as round clear areas in slide-mounted specimens

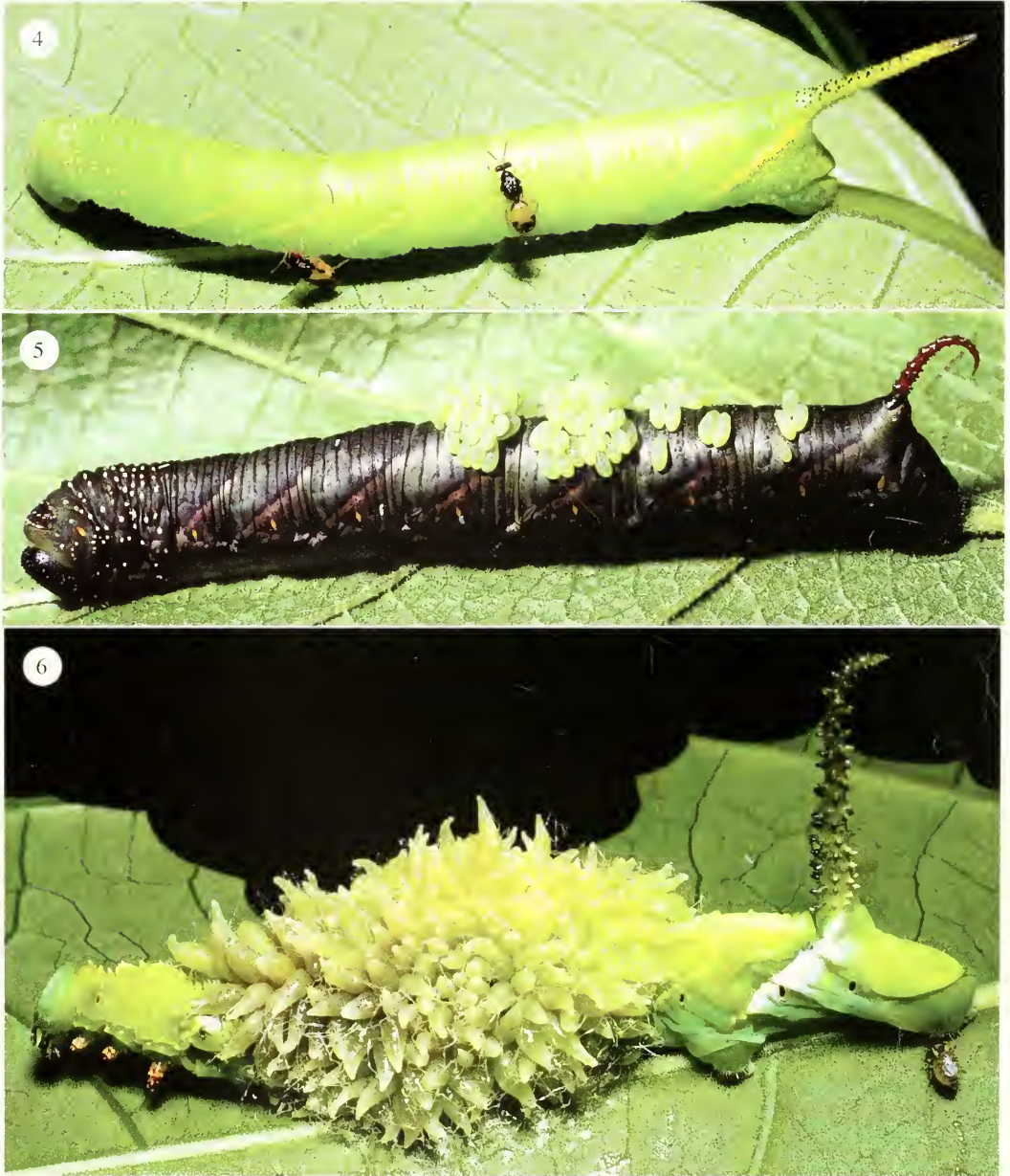

Figs. 4-6. Sphingid larvae attacked by *Euplectrus walteri*. 4, Two females waiting to oviposit after this penultimate (third) instar *Manduca barnesi* has molted to penultimate instar, the instar usually parasitized by *Euplectrus walteri* when attacking the larger of the species of *Manduca*. This caterpillar was within 24 hours of molting. The wasps clung tenaciously to the caterpillar despite being banged around in a plastic bag and roughly transported from the forest to the laboratory where the photograph was taken. 5, One or several clutches of partly grown *Euplectrus walteri* larvae feeding on an ultimate instar *Manduca dilucida* (dark morph). 6, A clutch of full-grown larvae just beginning to spin the first strands of silk of their aggregate cocoon on the back of a just-died penultimate (fourth) instar *Manduca florestan*. The distended ceratopogonid fly sucking caterpillar blood on the far right is *Forcipomyia* prob. *fuliginosa* (Art Borkent, pers. comm.).

(Figs. 19–21). The patterns of these sensillae along with the shape of the scape is often species-specific (Figs. 27–39).

Abbreviations for measurements and ratios are as follows (Figs. 23, 24): OD: OOD is the longest ocellar diameter compared to the distance between the ocellus and the eye (ocell-ocular distance); FW: EW is the ratio of the width of the face (distance between the margins of the eyes at the midpoint) to the width of the eye (distance from the margin of the eye to the edge of the eye when viewed from the front of the head). Height of the eye (EH) is the distance from the bottom of the eye to the top of the eye when viewed either from the front or laterally. The malar space (MS) is the distance from the bottom of the eye to the oral opening.

*Rearing.*—Wild-caught caterpillars were individually reared and databased as part of an ongoing inventory (<http://janzen.sas.upenn.edu> and Janzen and Hallwachs 2000) of all the caterpillars of the dry forest, cloud forest, and rain forest of the Area de Conservación Guanacaste (ACG) in northwestern Costa Rica (<http://www.acguanacaste.ac.cr>). Each caterpillar was maintained in a plastic bag or glass bottle at ambient temperatures while it and/or its parasitoids developed. When parasitoids appeared, or in this case, when the *Euplectrus* larvae were noted on the caterpillar, the caterpillar was isolated in a glass bottle with a small amount of food plant as a perch, to maintain humidity and serve as a substrate for the cocoon-spinning of the *Euplectrus* larvae. *Euplectrus* cocoons were monitored daily, and when the wasps eclosed, they were preserved in alcohol for later shipment to the senior author. *Euplectrus* adults were noteworthy for generally living at least 48 hours in the rearing container before dying (of starvation?) while other similarly-sized Eulophidae, Braconidae and Ichneumonidae rarely survive more than 24 hours in the rearing container without being fed.

This methodology of caterpillar and

parasitoid surveying suffers the limitation that once the caterpillar has been found in nature and brought into captivity, it and its parasitoids are no longer available for parasitization or hyperparasitization. This means that the percentages of parasitization recorded here represent the minimal possible. Equally confounding is that caterpillars are captured at all stages in their development, with the result that a simple comparison of the number of caterpillars parasitized against the number of caterpillars captured may severely underestimate the intensity of parasitization. This underestimation is because in the case of some species of *Euplectrus*, the wasp larvae kill the caterpillars during instars prior to the last instar. The number of “unparasitized” later instars found is therefore meaningless vis-a-vis *Euplectrus* percent parasitization. It should be emphasized that all sphingid caterpillars that have been found in the wild in the inventory are captured and reared in captivity, so there is no bias generated through seeking just those individuals parasitized by *Euplectrus*.

There were two kinds of *Euplectrus* identifications produced in this study. The most certain are those where wasps eclosed. All of those were identified by the senior author, a eulophid taxonomist. In 20–30% of the cases of parasitization by the uniquely distinctive external green larvae of *Euplectrus* (Fig. 1), the wasp larvae died when attempting their relocation below the cadaver or died because of severe rearing conditions (excessive heat, moisture, desiccation). For *Euplectrus floryae*, *E. walteri*, *E. mariae* and *E. josei*, the junior author (a *Euplectrus* ecologist) identified those dead larvae based on their distinctive cocoons, timing of attack, and taxon of host. These identifications are pooled with those of the senior author when attempting to tease out the intensity of attack and certain questions of parasitoid host specificity, but may also be treated as two separate classes of data at the wishes of the reader, since each record is individually documented in the da-

tabase and the identifier identified (<http://janzen.sas.upenn.edu>).

The basic collection locality and date information for all the reared *Euplectrus* de-

scribed here (Table 1) is deliberately minimal. More detailed information on a particular rearing may be found at <http://janzen.sas.upenn.edu>.

Table 1. Host associations for the 11 new species of reared *Euplectrus* described here from the ACG. All records are from wild-caught caterpillars of the species indicated. Details may be found in the individual records in Janzen and Hallwachs (2000).

<i>Euplectrus</i> species	Host	Number of hosts parasitized	Number susceptibles reared	% Parasitized
<i>anae</i>	<i>Sphacelodes vulneraria</i> (Hubner) (Geometridae)	1	197	0.5
<i>floryae</i>	<i>Enyo ocypte</i> (L.) (Sphingidae)	84	1010	8.3
	<i>Perigonia ilus</i> Boisduval (Sphingidae)	17	256	6.6
	<i>Perigonia lusca</i> (F.) (Sphingidae)	2	73	2.7
	<i>Aellopos fadus</i> (Cramer) (Sphingidae)	4	256	1.6
<i>ireneae</i>	<i>Motya absenzalis</i> (Walker) (Noctuidae)	1	29	3.5
<i>ivonae</i>	<i>Euscirrhopterus poeyi</i> Grote (Noctuidae)	1	174	0.6
<i>josei</i>	<i>Paectes lunodes</i> (Guenée) (Noctuidae)	11	73	15.0
<i>magdae</i>	<i>Dasylophia maxtla</i> (Shaus) (Notodontidae)	1	29	3.1
	<i>Dasylophia basitincta</i> Dognin (Notodontidae)	1	65	1.3
	<i>Dasylophia</i> nr. <i>goraxa</i> Schaus (Notodontidae)	1	12	8.3
<i>mariae</i>	<i>Concina mundissima</i> Walker (Noctuidae)	30	194	15.5
	<i>Elymiotis attenuata</i> (Walker) (Notodontidae)	7	213	3.3
	<i>Dasylophia</i> nr. <i>goraxa</i> Schaus (Notodontidae)	1	12	8.3
<i>orias</i>	Geometridae	1	1885	0.05
<i>romiei</i>	<i>Oxidercia toxca</i> (Stoll) (Noctuidae)	1	91	1.2
	<i>Cantethia spuria</i> (Boisduval) (Sphingidae)	1	110	0.9
<i>walteri</i>	<i>Manduca barnesi</i> (Clark) (Sphingidae)	1	34	2.9
	<i>Manduca dilucida</i> (Edwards) (Sphingidae)	4	112	3.6
	<i>Manduca florestan</i> (Cramer) (Sphingidae)	19	163	11.7
	<i>Manduca lanuginosa</i> (Edwards) (Sphingidae)	3	68	4.4
	<i>Manduca rustica</i> (F.) (Sphingidae)	3	26	11.5
	<i>Perigonia ilus</i> Boisduval (Sphingidae)	1	181	0.5
<i>xiomarae</i>	<i>Hemiceras clarki</i> (Notodontidae) Schaus	6	183	3.3
	<i>Hemiceras corema</i> Schaus (Notodontidae)	1	71	1.4
	<i>Hemiceras nigrescens</i> Schaus (Notodontidae)	1	521	0.2
	<i>Rosema attenuata</i> (Notodontidae)	14	111	12.6

#### KEY TO SPECIES OF COSTA RICAN EUPLECTRUS

1. Either face beneath toruli marked light brown or black (Fig. 15) or hind coxae brown to black (Fig. 11) ..... 2
  - Face beneath toruli all yellow (Figs. 12, 13, 16) and hind coxae light yellow or white (Fig. 10) ..... 9
2. Apical flagellomeres dark and contrasting with yellow to light brown F1 (Fig. 22) ..... 3
  - Apical flagellomeres same color as F1 or only slightly darker ..... 4
3. Width of face about 4X width of eye viewed from front (to measure FW:EW, see Fig. 24); posterior ocellus about 2X its own diameter removed from the margin of the eye (Fig. 49); mandibles yellow, male scapes greatly swollen (Fig. 50) ..... *furnius* Walker
  - Width of face about 2.5X width of eye viewed from front; posterior ocellus about 1.25X or less its own diameter removed from margin of eye; mandibles brown, male unknown ..... *zamorai*, new species

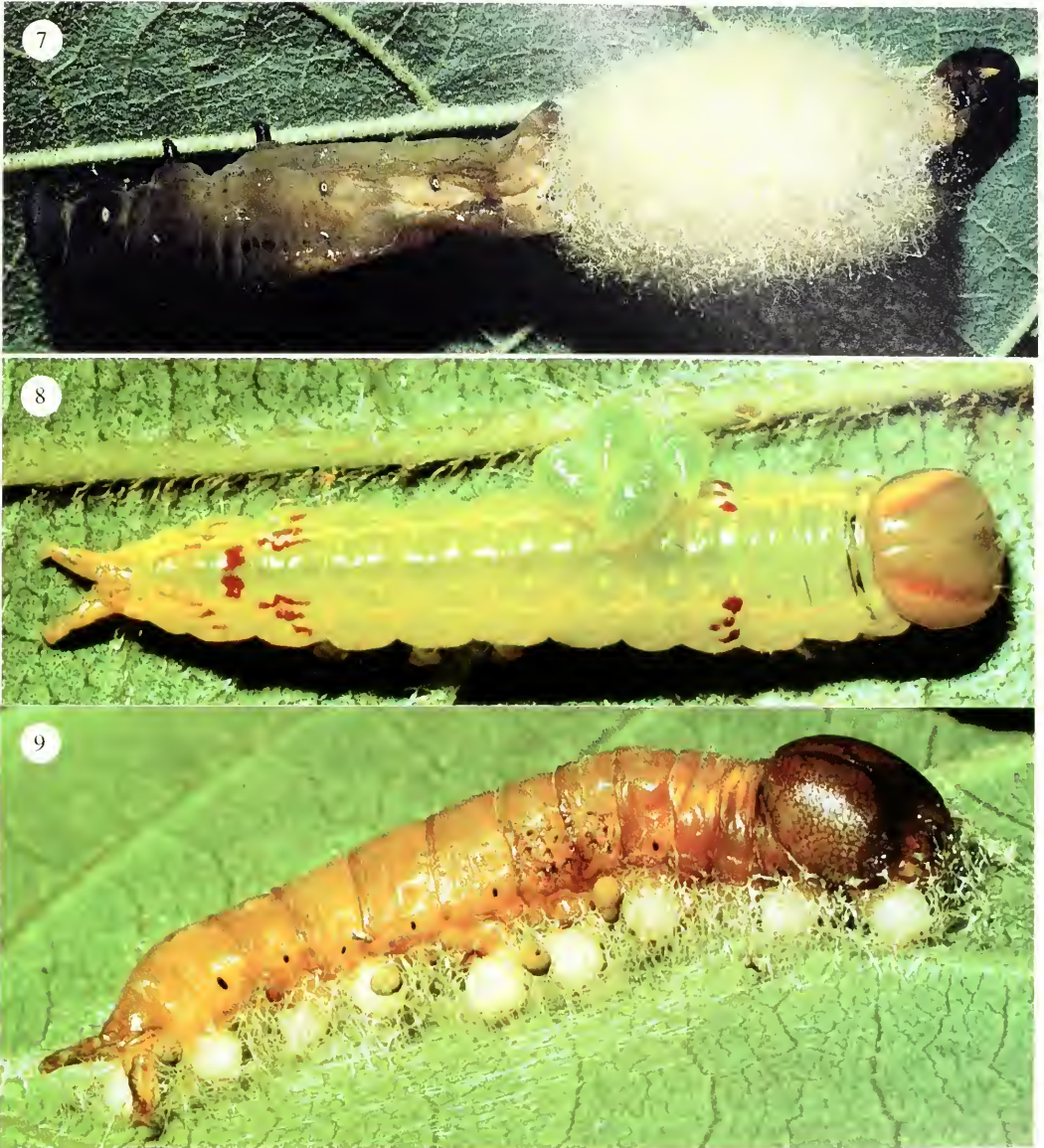

Figs. 7–9. Lepidopteran larvae attacked by *Euplectrus*. 7, The aggregate cocoon of a clutch of 100–200 *Euplectrus walteri* pupae ringing the semi-decomposed mummy of an ultimate (fifth) instar *Manduca dilucida* that was their host. The ruff of cocoons is a single dense unit with the cocoons tightly packed together and bound together by silk and glue. This is the only species of *Euplectrus* known to make an aggregate cocoon of this nature. 8, A normal-sized clutch of *E. xiomarae* larvae feeding on body fluids of a penultimate (fourth) instar *Hemiceras clarki* (Notodontidae). 9, The mummified cadaver of a penultimate (fourth) instar *H. pycnus clarki* (Notodontidae) caterpillar after the larvae of *E. xiomarae* have terminated their feeding on it and spun cocoons between the cadaver and the leaf, firmly silking/glueing the cadaver to the cocoons. Three beige spheroidal meconial pellets are suspended on the outer surface of the silk aggregate cocoons. This is the pupation method used by all species of *Euplectrus* known except for *E. walteri* (Figs. 4–7).

4. Hind coxa yellow or very light brown (Fig. 10) ..... 5
  - Hind coxa dark brown or black (Fig. 11) ..... 6
5. First tarsomere of hind leg about equal in length to second; postero-lateral margin of scutellum overlapping metanotum (Fig. 43) ..... *carlowae*, new species
  - First tarsomere of hind leg much longer than second; postero-lateral margin of scutellum not overlapping metanotum ..... *edithae*, new species
6. Posterior margin of scutellum overlapping anterior edge of metanotum medially (Fig. 68, 69); anterior median propodeal carina split into a V-shape, not enlarged and cup-like (Fig. 69) ..... *rojasi*, new species
  - Posterior margin of scutellum not overlapping anterior edge of metanotum medially, at least two distinct alveoli visible at anterior edge of metanotum (Figs. 53, 59); anterior median propodeal carina expanded and protruding from surface of propodeum, invaginated and cup-like (Figs. 42, 43) ..... 7
7. One pair of small setae (ss2) present between lateral ocelli (Figs. 66, 82) .. *oriae*, new species
  - No small setae (ss2) between lateral ocelli (Fig. 85) ..... 8
8. Mandibles brown; malar suture present at least below eye margin (as in Fig. 67) ..... *valverdi*, new species
  - Mandibles yellow; malar suture absent ..... *xiomarae*, new species
9. Occiput between posterior ocelli with 2 pairs (4) of small setae (ss2) (Fig. 46) ..... 10
  - Occiput between posterior ocelli with 1 pair (2) or no small setae (ss2) (Fig. 49) ..... 11
10. Yellow color on face extending about 1/2 way up eye margin and above level of toruli (Fig. 12) ..... *floryae*, new species
  - Yellow color on face restricted to below and between toruli, not extending up along margin of eye (as in Figs. 13, 14) ..... *josei*, new species
11. Posterior ocellus less than 1 diameter from edge of eye (see Fig. 23); width of eye more than 1/2 width of face (Fig. 24) ..... *irenae*, new species
  - Posterior ocellus more than 1 diameter from edge of eye; width of eye less than 1/2 width of face ..... 12
12. Toruli separated by about 4X their own diameter (Fig. 13). ..... *walteri*, new species
  - Toruli separated by about 2–2.5X their own diameter ..... 13
13. Funicular segments F1–4 all about 3X as long as wide and F1–3 all about same length as club (Fig. 26) ..... *hansoni*, new species
  - At least one of funicular segments F1–4 less than 3X as long as wide, generally only 2X as long as wide or less; F2–4 usually much shorter than club ..... 14
14. Enlarged seta number 5 (S5, Fig. 23) present ..... 15
  - Enlarged setae number 5 absent ..... 18
15. Anterior metanotum with a single large alveolus, sometimes divided medially into two large alveoli (Fig. 59); propodeum distinctly reticulate over entire median surface ..... *madgae*, new species
  - Anterior metanotum with a thin line of small alveoli (Fig. 40); propodeum not distinctly reticulate over surface, usually lightly reticulate or smooth and shiny ..... 16
16. Petiole distinctly wider than long; propodeum adjacent to median carina with irregular small carinae, appearing rugose; metasoma light brown to brown in apical half ..... *anae*, new species
  - Petiole as long as wide or longer than wide; propodeum adjacent to median carina smooth or very lightly reticulate; metasoma dark brown to black apically ..... 17
17. F1 about 3X as long as wide ..... *solitarius* Ashmead
  - F1 about 2X as long as wide ..... *comstockii* Howard
18. Yellow coloration of face extending laterally beyond the outer edge of the toruli, often reaching to under the eye (Fig. 16) ..... *ivonae*, new species
  - Yellow coloration of face restricted to between and below the toruli, occasionally slightly laterad of the toruli, but not to near or under eye ..... 19
19. Propodeum immediately laterad of median carina with small irregular carinae (appearing

- somewhat rugose) or lightly reticulate; petiole wider than long. Male scape with small brown sensory area on ventral edge which extends at most (2/3 or more) of length of scape (Fig. 30) with 2–3 irregular rows of sensillae ..... *mariae*, new species
- Propodeum laterad of median carina mostly smooth; petiole as wide as long. Male scape with small brown sensory area on ventral edge which extends for less than 1/2 length with only a single row of sensillae (Fig. 31) ..... *ronnici*, new species

ECOLOGY

*Euplectrus floryae* Schauff.—This species is a common parasitoid (Table 1) of second instar *Enyo ocypte* (Sphingidae), a medium-sized caterpillar that feeds on Dilleniaceae in the dry forests of the ACG (Fig. 3). It is likely that this small sphingid supports most of the *Euplectrus floryae* population in these forests. This *Euplectrus* has not been found in any of the ACG rain forest or cloud forest. Parasitized *Enyo ocypte* larvae have been found feeding on *Tetracera volubilis* L. and *Curatella americana* L. This sphingid feeds also on *Davilla kunthii* A. St.-Hil. and *Doliocarpus deutatus* but in such low numbers that the absence of *Euplectrus floryae* records on these caterpillar food plants may be a sampling artifact. The parasitized *Enyo ocypte* caterpillars were found in sites ranging from fully isolated habitats (mostly *Curatella americana*) to the deep shade of old-growth forest (mostly *Tetracera volubilis* L.).

Only one *Enyo ocypte* wild-caught first instar was found to have *Euplectrus floryae* on it, and that one died without its three parasite larvae completing development (92-SRNP-835). However, many *Enyo ocypte* larvae have been found in nature as second and third instars with *Euplectrus floryae* feeding on them. Only two fourth and no fifth (last) instar *Enyo ocypte* larvae have been found with *Euplectrus floryae* on them. These records imply that once the caterpillar has reached the penultimate or last instar, it is immune or unattractive to the wasp adult. It appears that oviposition normally occurs on second or third instar larvae. A single caterpillar normally supports 5–10 *Euplectrus floryae* larvae in a single group. We as-

sume that this represents a single oviposition by a single female.

There is no suggestion that the sphingid caterpillar molts after wasp oviposition occurs. The wasp larvae develop from minute, glabrous, green protuberances in a cluster to a tight cluster of large globular green larvae (Fig. 3) at the same point on the back over a period of 4–8 days. They do not move about and feed with their heads always inserted in the same hole. The caterpillar does continue to eat leaves during this period, but stops feeding in 1–2 days before the wasp larvae release their feeding position and move to underneath the moribund caterpillar to spin their cocoons on the leaf underside (e.g. Figs. 2, 3) (where the caterpillar also rests when unparasitized). The beige/brown silk cocoons are adjacent with their long axis at right angles to the long axis of the caterpillar, alternately oriented to the left and right, with the meconial pellet clearly visible at the tip of the cocoon. The cocoons are tightly glued between the ventral surface of the cadaver and the leaf. The cocoons are enmeshed in a distinctive silken matrix resembling a loose basket. The cadaver becomes a mummified strap of tissue perched on top of the cocoons.

The wasps spend 7–12 days in their cocoons. However, while wasp eclosion date is accurately recorded (see text account of specimens examined), some of the shorter development times of 7 days may be cases where the cocoons were not noticed for 1–2 days after they were spun. It is likely that the usual time in the cocoon is about 8 days. There is no evidence of dormancy by pupae in cocoons spun at any time in the rainy season. Only once has a caterpillar parasitized by *Euplectrus floryae* been

found in the dry season, and in this case there was no indication of dry season dormancy (92-SRNP-524).

The overall phenology of *Enyo ocypte* second and third instars in this dry forest habitat is that they first appear on *Curtella americana* L. in small numbers in February–April, and then in much larger numbers in May–June. In June–July, there are large numbers on *Tetracera volubilis* L., followed by a very few individuals on both species of plants through December. One *Euplectrus floryae* record is in February and one at the end of September. As a general pattern, it appears that the *Euplectrus floryae* population could have as many as 4–5 consecutive generations on the *Enyo ocypte* population beginning in early May–July. It survives the August-to-April last half of the rainy season and nearly all of the dry season as non-reproducing adults. It is unknown whether they migrate to a wetter part of Costa Rica, or “hide” in local moist areas within the dry forest. They do not appear in Malaise traps at any time of the year, even when these traps are in the middle of the forest habitats in which they are breeding, only a few meters from parasitized caterpillars. The overall results of the caterpillar rearing program in this forest suggests that *Euplectrus floryae* does not use an alternate host caterpillar species or family at these other times of the year.

The few records of *Euplectrus floryae* from *Cautethia spuria*, two records from *Aellopos fadus*, and 18 records from *Perigonia ilus* and *Perigonia lusca* (these two species are nearly indistinguishable as larvae) (Table 1), probably represent minority hosts for *Euplectrus floryae*. These four sphingids suffer no more than 2% parasitization by *E. floryae*, while, for example, of 200 larvae of *Enyo ocypte* collected in the second and third instars (the key susceptible stages), 25% had *Euplectrus floryae* on their backs. The parasitization of non-*Enyo ocypte* caterpillars occurs at the same time of year (the first half of the rainy season)

as do the bulk of the rearing records from *Enyo ocypte*.

*Euplectrus floryae* is essentially the only hymenopterous parasite in the ACG dry forest habitat that kills *Enyo ocypte* prior to the last instar (except for two braconid rearings and one ichneumonid from 1240 caterpillars). The other parasitoids of *Enyo ocypte* are two species of Tachinidae; their larvae emerge from the caterpillar at the end of the last instar (*Drino piceiventris*) or the adult fly ecloses from the pupa (*Belvosia* sp.). While this forest has thousands of species of hymenopterous and dipterous parasitoids of caterpillars, *Euplectrus floryae* shares *Enyo ocypte* with only two of them. The two fly parasites may get into their hosts as early as the second instar, but more commonly do so in the 3–5th instars. In effect, *Euplectrus floryae* utilizes its portion of the host population early in caterpillar development, and then the tachinid flies take their portion after that.

The four species of dilleniaceous plants used by *Enyo ocypte* in this dry forest habitat are also fed on by caterpillars of the small sphingids *Aleuron iphis*, *Unzela japix*, *Unzela pronoe*, and *Pachygonidia drucei*. However, of a total of 463 caterpillars of these species reared to date, none were parasitized by *Euplectrus*. These plants are also fed on by five species of Noctuidae, and no *Euplectrus* have been found on these caterpillars.

In summary, *Euplectrus floryae* is unambiguously a specialist on *Enyo ocypte* in this dry forest, but it uses at least four other species of very abundant sphingid caterpillars, none of which feed on the *Enyo ocypte* host plants, at a low frequency. It is “ignoring” in some sense at least 50 other species of sphingid caterpillars and a thousand or more species of other caterpillars whose size would not preclude successful *E. floryae* development in this dry forest habitat. Like all other *Euplectrus* reared in the ACG, it has never been found in rainforest or cloud forest, either with traps or by rearing.

*Euplectrus ireneae* Schauff.—This species has been reared only once out of 29 rearings, from a rare and highly seasonal small green noctuid caterpillar, *Motya abseuzalis* L. This caterpillar feeds on the leaves of *Conocarpus erecta* (Combretaceae) during the second month of the rainy season in the ACG dry forest at the edge of the coastal mangrove forest. *Euplectrus ireneae* uses its last instar caterpillar host the same way as does *Euplectrus mariae*. This host caterpillar, and the other caterpillars on the edges of the ACG mangrove swamps, have not yet been censused sufficiently to be able to say anything about the relative abundance or specificity of *Euplectrus ireneae*.

*Euplectrus iconae* Schauff.—This species has been reared only twice out of 174 rearings of an extremely abundant and highly seasonal noctuid *Euscirrhopterus poeyi*. This caterpillar feeds on *Pisonia macranthocarpa* Donn.-Sm. (Nyctaginaceae) only during the first week before and after the rainy season begins. This small eulophid wasp may either occur at an extraordinarily low density or it normally uses some other species of caterpillar that has not yet been censused in the caterpillar inventory and feeds on some other host plant *Euscirrhopterus poeyi* Grote and two very low density leaf-rolling pyralids, *Psara hesperialis* and *Psara prunivides*, are the only species of caterpillars feeding on *Pisonia macranthocarpa* Donn.-Sm. in the ACG dry forest.

*Euplectrus josei* Schauff.—This species has a relationship to its sole host, *Paectes lunodes* (Noctuidae), that is essentially identical to that of *Euplectrus mariae* to its primary host.

*Euplectrus magdae* Schauff.—This species occurs at very low density on *Dasylophia* spp. (Notodontidae) in dry forest (Table 1). It shares this host genus with *Euplectrus mariae*, which is much more abundant, however on other caterpillars.

*Euplectrus mariae* Schauff.—This species appears to be a monophagous specialist

on penultimate instar larvae of *Concana mundissima*, a medium-small noctuid that feeds on three species of Malpighiaceae (*Byrsonima crassifolia* (L.) Kunth in HBK, *Hiraea reclinata* Jacq., *Heteropterys laurifolia* (L.) A. Juss. in the ACG dry forest and on penultimate instar *Elymiotis attenuata* (Notodontidae) also feeding on Malpighiaceae (Table 1). The few records of parasitizing last instar larvae may be correct, or may have been penultimate instar larvae. Its biology of host use is essentially identical to that of *Euplectrus floryae*, except that *Euplectrus mariae* has been found only in the May–June first two months of the rainy season (*Concana mundissima* also breeds almost entirely during the first three months of the rainy season). There is no hint of pupal dormancy by *Euplectrus mariae*, so we assume that it passes the remainder of the year as a reproductively dormant adult or migrates to a wetter area to the east to have further generations.

There are 37 records of *Euplectrus mariae* from about 150 suitable-sized caterpillars of *Concana mundissima* captured to date. No other noctuid caterpillar resembling, or taxonomically similar to, *Concana mundissima* is attacked by any species of *Euplectrus* in this forest. This small *Euplectrus* (5–10 larvae per caterpillar) could conceivably parasitize any one of at least a thousand species of caterpillars living in the habitat of *Concana mundissima*.

*Euplectrus mariae* shares *Concana mundissima* with 4 species of microgastrine braconid wasps and four species of tachinid flies. All together, these parasitoids take about 35% of the *Concana mundissima* caterpillars (which is exceptionally high for this inventory), and *Euplectrus mariae* is responsible for about half of this caterpillar mortality.

*Euplectrus walleri* Schauff.—This is a low frequency parasitoid of penultimate (usually) and ultimate (rarely) larvae of various species of *Mutilla* (Sphingidae) (Table 1). There has been one or more rearing of *Euplectrus walleri* from all five of the

common *Manduca* species in the ACG dry forest. The absence of *Euplectrus walteri* from the two rare species (*Manduca sexta*, *Manduca hannibal*) is probably due to the very low numbers of these caterpillars found to date. The single record of *Euplectrus walteri* from 381 caterpillars captured of *Perigonia ilus* undoubtedly represents an "abnormal" host record. These records indicate that either *Euplectrus walteri* is ignoring the more than 50 other species of sphingid caterpillars in this habitat (more than 15,000 rearing records), or is unable to develop in them (though the single *Perigonia ilus* record implies that the latter is unlikely). The larvae and cocoons of *Euplectrus walteri* are so distinctive that it can be stated with certainty that they are not using the caterpillars of any other species in the ACG dry forest (based on a sample of more than 50,000 caterpillars large enough to potentially host at least a small group of *Euplectrus walteri* larvae)

A single *Euplectrus walteri* (Fig 4) lays up to several hundred eggs on the back of a (usually) penultimate instar *Manduca*, and the larvae develop into a large patch of fat elongate green larvae tightly packed into one feeding area (Fig 6). In all cases, all the larvae have been bunched together in one place, as if all the eggs were laid there by a single female. In the one case of oviposition observed, there were two females on the caterpillar (Fig 4) but only one was observed to oviposit. As with other *Euplectrus* larvae, they are strongly attached to the caterpillar cuticle by their mouthparts. Before the end of the caterpillar's penultimate instar they have developed to full size, released their hold, and spread into a ruff around the moribund caterpillar as they spin their cocoons (Fig. 7). The cocoons are stuck to one another and constitute a tight brown thick ruff around the caterpillar, which is dead but still clinging to the host plant leaf by the proleg crochets. When rearing this species, it is important not to disturb the caterpillar or wasp larva at the time that

they release their hold on the caterpillar and move to their spinning site, as they easily fall off the caterpillar, become disoriented, and die. The wasps eclose over a 1–2 day period 10–14 days after spinning. There has been no suggestion of pupal dormancy during any of the 16 rearings.

*Euplectrus walteri* has been found parasitizing *Manduca* from June through November. *Manduca* caterpillars are absent from the ACG dry forest habitat for the other months of the year and are extremely rare after July. Either they pass the end of the rainy season and the dry season as reproductively dormant adults, or they migrate to the wetter portions of the ACG and points further to the east in the Caribbean lowland rainforest. However, we favor the former hypothesis since there are to date neither rearings nor Malaise trap records of *Euplectrus walteri* from any wet portion of Costa Rica.

*Euplectrus walteri* occurs at low frequency (32 cases out of more than 230 penultimate instar records), and shares its *Manduca* hosts with a microgastrine braconid (*Microplitis* sp.), three species of ichneumonidae (Janzen and Gauld 1997), and six species of Tachinidae in the ACG dry forest. It is important to recall that if the caterpillar is collected prior to the penultimate instar, it cannot have *E. walteri* in it. In the three cases where *Euplectrus walteri* appeared to have attacked a last instar caterpillar, it could either be an exceptional record or the caterpillar was incorrectly determined to be a last instar.

In addition to being the largest of the *Euplectrus* species reared in this study, *Euplectrus walteri* produces 10–20 times the number of wasps per caterpillar attacked as do the other species, and attacks the largest caterpillars known to be attacked by any species of *Euplectrus*. *Euplectrus walteri* also uses 3–6 days longer in the pupal stage than do the other smaller species of *Euplectrus*.

*Euplectrus xiomarae* Schauff.—This spe-

cies is a specialist on early instar larvae of *Hemiceras* and *Rosema* (Notodontidae) feeding on *Inga* (Fabaceae). It has not been found on any of the tens of species of other caterpillars feeding on *Inga* in the same dry forest.

## TAXONOMY

### *Euplectrus anae* Schauff, new species (Figs. 34, 40–42)

*Diagnosis*.—Face below and between toruli yellow, not extending to eye or past gena (Fig. 13); legs yellow; one pair of setae ss2 between lateral ocelli (as in Fig. 70); all setae S1–6 present (see Fig. 23); longitudinal carina on mesoscutum nearly complete, midlobe without small setae; scutellum finely reticulate; propodeum laterad of median carina nearly smooth; petiole wider than long.

This species is similar to *E. magdae* which also has all the major setae on the face present. It can be differentiated by the petiole being longer than wide whereas related species all have the petiole as wide as long or wider than long.

*Description*.—Female. Body length 2.25mm. Color: body mostly black except the following: face below and between toruli yellow, not extending to eye or past gena; antenna with scape white to light yellow, flagellum yellow; mandibles white; legs yellow; dorsal metasoma with large central yellow area extending from just behind petiole posteriorly for about 2/3 length, becoming darker in posterior 1/4, laterally dark brown; ventral metasoma yellow. *Head*. Dorsally with one pair of minor seta ss2 between posterior ocelli (as in Fig. 70) inserted near occipital carina; seta S5 reduced, setal row sr2 present as 2–3 irregular rows of 10–15 setae reaching the bottom of the eye; occipital carina present medially; width of eye: width of face 12:35; posterior margin of eye separated from margin of head ventrally. Ratio of MS:EH 15:29; lateral ocellus more than 1 diameter from eye (OD:OOD 12:10).

Face below eyes rounded, not abruptly narrowing. Vertex under anterior ocellus reticulate to alutaceous. Toruli separated by about 2–2.5× their own diameters. Malar suture absent. Area under eye irregularly reticulate to alutaceous. Scape 4× as long as wide. Ratio of funicular segments 12:11:11:11:16, width 6 at F1 to 7 at club, each flagellar segment with scattered semierect brown setae, not arranged as whorls basally. *Mesosoma*. Pronotum anterior to transverse carina with scattered setae, finely rugosely reticulate, posterior to carina more openly reticulate and shiny. Mesoscutum (Fig. 42) rugosely reticulate in anterior 1/2, becoming more open, smooth, and shiny posteriorly. Midlobe with median carina fading in anterior 1/4 otherwise complete, slightly sunken posteriorly, posterior setae even with surface, with no small setae antero-laterally. Dorsal axillar/scutellar margin with broad, nearly straight deep furrow with flat bottom. Axillae shiny, openly reticulate, becoming smooth at posterior margin. Scutellum finely reticulate and shiny medially to more finely and striate reticulate laterally, pointed at anterior margin with axillae. Metanotum bordered anteriorly and medially by small alveoli, medially expanded into a triangular flange (Fig. 40) with submedian carinae below. Propodeum laterad of median carina sunken and irregularly carinate alveolate, becoming nearly smooth laterally to the step-like plica, median carina with anterior cup-like flange rounded and deeply invaginated. Area around spiracle finely reticulate, lateral edge of spiracle raised above surface, with antero-lateral flange large and well defined, with 6–8 setae laterad and below spiracle. Posterior margin of propodeum with irregular alveolae and carinae. Petiole in dorsal view wider than long (15:10) and rugose dorsally becoming smooth at posterior margin. *Metasoma*. Ovate, about 1.5× as long as wide, with continuous brown margin laterally. Legs. Ratio of hind tibial spur 1:spur 2:tarsus 1:

T2:T3:T4. 35:23:22:10:8:20. Forewing. Hyaline, about  $2.1\times$  as long as wide. Costal cell with 2 irregular rows of setae ventrally. Venation yellow, ratio of postmarginal: stigmal 35:20.

*Male*.—Similar to female except: body length 1.8 mm; face below toruli lighter yellow, almost white; legs yellow or white; dorsal metasoma with large central white spot, dark brown posteriorly; antenna with scape white slightly swollen on ventral surface, with sensory area slightly darker and with several irregular rows of sensillae extending for about  $3/4$  length (Figs. 34, 41); funicle ratios 11:10:10:10:15, width about 6 anteriorly to 7 posteriorly, with numerous semi-erect brown setae on each flagellomere.

*Hosts*.—*Sphacelodes vulneria* (Geometridae)

*Distribution*.—Known only from the ACG.

*Types*.—Holotype female on point: Costa Rica, Guanacaste Prov., Area de Conservación Guanacaste, Lambert N309450 E355300, 10 m., V. 11, 1992, 92-SRNP-747, D.H. Janzen & W. Hallwachs. ex. *Sphacelodes vulneraria* (Geometridae), (deposited in INBIO). Paratypes: 3 females and 2 males with the same data as holotype (deposited in USNM).

*Etymology*.—This species is named in honor of Ana Leticia Martínez Eras in special recognition of her dedicated attention to the Accounting Office for the Area de Conservación, Guanacaste.

*Euplectrus carlowae* Schauff, new species  
(Figs. 25, 43)

*Diagnosis*.—Face under toruli black; all legs, including hind coxae, yellow; first funicle about same length as antennal club (Fig. 25); posterior margin of scutellum extended over anterior margin of metanotum laterally, anterior edge of metanotum medially expanded outward and divided into two areolae; hind basitarsus about equal in length to second tarsomere. *Eu-*

*plectrus carlowae* is unusual in having the hind basitarsus nearly equal in length to the second tarsus, while in all other species examined the first tarsomere is much longer than the second. It is also somewhat unusual in having a dark face and all yellow legs (although this is shared with *E. edithae*). Other species treated here with the face dark brown or black have at least the hind coxa darkened (*valverdei*, *zamorai*, *xiomarae*). The lateral expansion of the scutellum over the anterior edge of the metanotum is also distinctive.

*Description*.—Female. Body length 2.2 mm. Color: body mostly black except the following: antenna with scape yellow to brown, flagellum light brown becoming darker brown apically; mandibles light brown; enlarged setae on vertex dark brown to black; legs yellow; dorsal metasoma dark brown to black behind petiole with yellow inverted T-shaped spot medially, posterior half dark brown, ventral metasoma dark brown behind petiole, then yellow up to about midpoint, then dark brown. *Head*. Dorsally with 2 minor seta ss2 between posterior ocelli, all setae S1–6 present, setal row sr2 present as 2 irregular rows of about 10 setae reaching to bottom of eye; occipital carina weak medially; width of eye: width of face (30:13), posterior margin of eye not nearly contiguous with posterior margin of head over most of length. Ratio of MS:EH 17:29; lateral ocellus more than 1 diameter from eye (OD:OOD 7:8). Face below eyes rounded, not abruptly narrowing. Vertex under anterior ocellus reticulate. Toruli separated by about  $2\times$  their own diameters. Malar suture absent. Area under eye lightly reticulate. Scape  $5.5\times$  as long as wide. Ratio of funicular segments 18:17:15:13:18, width 5 at F1 to 6 at club, flagellar segments with small whorls of brown setae basally. *Mesosoma*. Pronotum anterior to transverse carina with scattered setae, finely rugosely reticulate, posterior to carina reticulate and shiny. Mesoscutum (Fig. 43) reticulate, becoming more open,

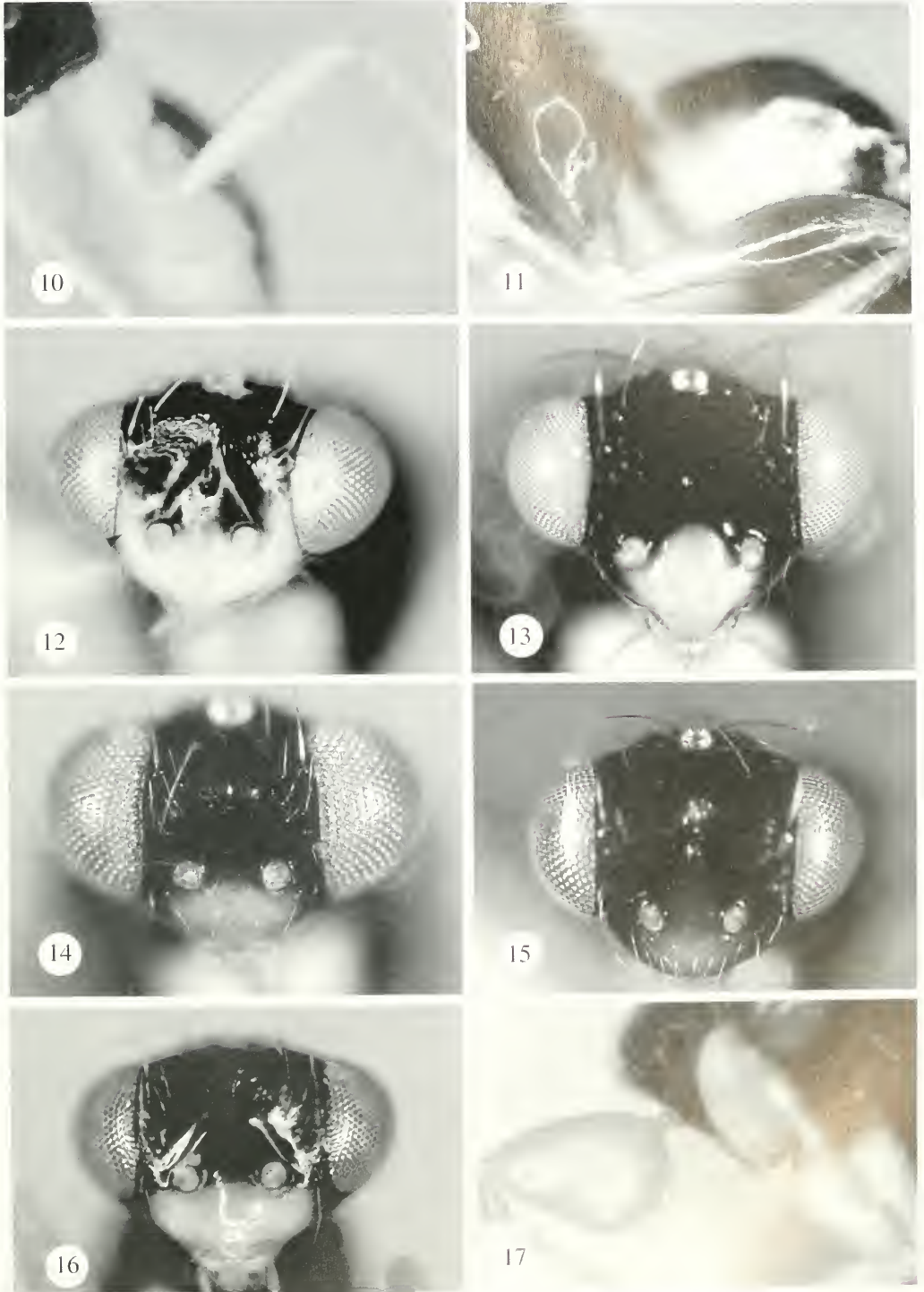

Figs. 10-17. *Euplectrus*. 10-11, Hindlegs. 10, *E. floryae*. 11, *E. xiomaruae*. 12-16, Dorsal view. 12, *E. floryae*. 13, *E. walleri*. 14, *E. irenae*. 15, *E. orias*. 16, *E. ivonae*. 17, Male scape, *E. calyculi*.

smooth, and shiny posteriorly. Midlobe with median carina fading in anterior 1/4, not noticeably sunken posteriorly, with no small setae antero-laterally, posterior setae even with surface. Dorsal axillar/scutellar margin with broad, distinctly curved deep furrow with flat bottom. Axillae openly reticulate. Scutellum reticulate to alutaceous, smooth along posterior margin, posterior margin extended over anterior margin of metanotum laterally. Metanotum laterally covered by scutellum, medially with two distinct protruding alveoli, below shiny and smooth to lightly reticulate. Propodeum laterad of median carina shiny and smooth to the step-like plica with occasional faint hints of reticulation, median carina distinctly raised above surface, with large, rounded anterior cuplike flange. Area around spiracle reticulate, spiracle slightly raised and even with surface, with antero-lateral flange present, with 7 setae laterad and below spiracle. Petiole in dorsal view as long as wide (12:11), rugose dorsally. *Metasoma*. Ovate, about 2× as long as wide. Legs. Ratio of hind tibial spur 1:spur 2:tarsus 1:T2:T3:T4. 38:22:17:17:12:18. Forewing. Hyaline, about 2.4× as long as wide. Costal cell with 1 irregular row of setae ventrally. Venation yellowish, ratio of postmarginal:stigmatal 31:16.

*Male*.—Unknown.

*Hosts*.—Unknown.

*Distribution*.—Known only from Puntarenas and Alajuela.

*Types*.—Holotype female on point (antenna and wing slide-mounted) with data: "Costa Rica, Puntarenas, R. F. Golfo Dulce, 24 Km. W. Piedras Blancas, 200 m., IV-V 1992. P. Hanson." (deposited in INBIO). Paratypes: 2 females with same data as holotype except II-III. 1989, 2 females XII. 1989-III. 1990, and 2 females at 100m, III-V. 1989; 1 female Costa Rica: Alajuela, 5km W. San Ramon, 1200m, I. 1997, O. Castro & P. Hanson (deposited in USNM, BMNH).

*Etymology*.—This species, collected only

from Malaise trapping, is named for Ms. Tami Carlow of the Systematic Entomology Lab, USDA who was responsible for most of the scanning electron micrographs used in this paper and also assisted with specimen mounting, labelling and a variety of other tasks vital to the completion of this work.

### *Euplectrus comstockii* Howard

(Figs. 27, 44)

*Euplectrus comstockii* Howard 1880:158.

*Diagnosis*.—Legs yellow; face under toruli yellow; first funicle 2× as long as wide; seta 5 present (see Fig. 23), but reduced; with one pair of small setae (ss2) between posterior ocelli (as in Fig. 66); F1 2× as long as wide; median longitudinal mesoscutal carina nearly complete; scutellum lightly reticulate and shiny medially, becoming striate laterally; anterior metanotum with large, obvious line of alveoli (Fig. 44), central transverse band narrow, smooth; propodeum adjacent to median carina lightly reticulate, shiny. Petiole wider than long. *Metasoma* mostly yellow, becoming brown posteriorly. Male scape slightly (Fig. 27) expanded near apex, with 2 irregular short rows of sensillae.

*E. comstockii* is most similar to *solitarius* but can be separated by the petiole which is longer than wide in *solitarius* and wider than long in *comstockii* and the antennae which has F1 2× as long as wide in *comstockii* and 3× as long as wide in *solitarius*.

*Distribution*.—Widespread in United States, Central and South America.

*Hosts*.—The following records are primarily drawn from the literature (Burks 1979, Noyes 1998). In a few instances they have been verified from specimen label data in collections (USNM, CNC). It is our opinion, based on data from the species reared in this study, that at least some of these records probably represent misidentifications of either the parasite or the host. *Alypia octomaculata*; *Anomis illita*; *Autogra-*

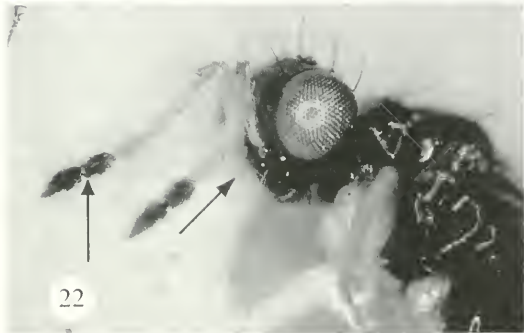
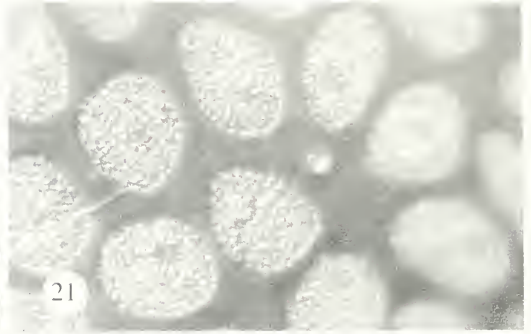
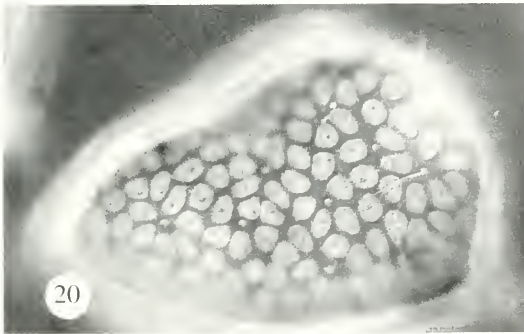
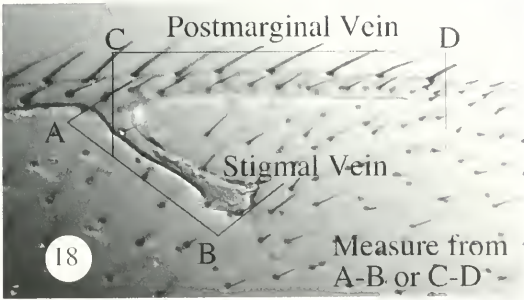

Figs. 18–22. *Euplectrus*. 18, Forewing venation. 19, *E. xiomarac*, male scape, 20–21, *E. valverdei*, male scape. 22, *E. zamorai*, head and antennae.

*pha* sp.; *Caradrina* sp.; *Hadena luteago*; *Helicoverpa armigera*; *Helicoverpa zea*; *Heliiothis* sp.; *Heliiothis virescens*; *Hypeua scabra*; *Leucaenia latiuscula*; *Neogalea sunia*; *Plusia* sp; *Pseudoplusia includens*; *Seleuisa sueroides*; *Spodoptera frugiperda*; *Spodoptera ornithogalli*; *Trichoplusia ni* (Noctuidae); *Fernandella finetaria* (Geometridae); *Rothschildia aroma* (Saturniidae).

*Types*.—Howard described this species from “two male specimens”. He indicated that the original specimens had been collected by Comstock and that “upon looking them up, I found that two adults had

issued”. In the U.S. National Museum collection, there is a series containing both males and females, on cards and points and all bearing the USNM type no. 2653. The type catalog entry for this species lists both male and female specimens collected in 1878 and 1880 by W.H. Patton and S. A. Schwarz (not Comstock) and the number of specimens listed as “many”. Howard made no mention of localities in his original description, but all the USNM specimens with locality labels are from Selma, Alabama, collected in 1880, except one collected in 1878 from Florida. Ac-

cording to the description, the types were reared in 1879 during fieldwork conducted by Comstock. None of the points or cards contains only 2 males. Given these facts, we believe it likely that none of the specimens labelled as types in the USNM collection are in fact the specimens that Howard used for his original description, but rather the specimens currently labelled as types are specimens used by him for a subsequent redescription (Howard 1885). Since the original type specimens are lost, we are erecting a neotype (present designation). This specimen is one of the series labelled as types. It is a female on a card with 3 other specimens and has been marked with an "N" in black ink. The label data is: "Selma, Oct., 81. Patton. Type no. 2653, U.S.N.M."

*Euplectrus edithae* Schauff, new species  
(Fig. 39)

*Diagnosis*.—Face black below toruli (as in Fig. 15), legs yellow; one pair of setae ss2 between lateral ocelli; flagellum brown, funiculars about 2× as long as wide; malar space nearly equal to eye height; petiole as wide as long; postmarginal less than 1.5× stigmal. This combination of a black face below the toruli and yellow hind coxae is found only in this species and in *E. carlowae*. In addition, *E. carlowae* has the second tarsomere of the hind leg nearly equal in length to the first (second tarsomere much shorter than first in *edithae*) and the lateral scutellum is expanded and overlaps the metanotum (lateral scutellum not overlapping metanotum in *edithae*).

*Description*.—Female. Body length 2.2–2.3 mm. Color: body mostly black except the following: antenna with scape yellow to brown, flagellum brown; mandibles yellow; enlarged setae on vertex yellow to dark brown; legs yellow; dorsal metasoma dark yellow behind petiole and ventrally, dark brown laterally. *Head*. Dorsally with 2 minor seta ss2 between posterior ocelli, seta S5 reduced, setal row sr2 present as 2

irregular rows of about 8 setae reaching to bottom of eye; occipital carina reduced; width of eye: width of face (40:13), posterior margin of eye not nearly contiguous with posterior margin of head over most of length. Ratio of MS:EH 19:22; lateral ocellus more than 1 diameter from eye (OD:OOD 5:10). Face below eyes abruptly narrowing. Vertex under anterior ocellus reticulate. Toruli separated by about 2× their own diameters. Malar suture absent. Area under eye lightly reticulate. Scape 6× as long as wide. Ratio of funicular segments 11:11:11:11:16, width 5 at F1 to 6 at club, flagellar segments with small whorls of brown setae basally. *Mesosoma*. Pronotum anterior to transverse carina with scattered setae, finely rugosely reticulate, posterior to carina reticulate and shiny. Mesoscutum reticulate, becoming more open, smooth, and shiny posteriorly. Mid-lobe with median carina complete, not noticeably sunken posteriorly, with no small setae antero-laterally, posterior setae even with surface. Dorsal axillar/scutellar margin with relatively narrow, parallel sided furrow making anterior margin of scutellum distinctly V-shaped. Axillae openly reticulate. Scutellum reticulate to alutaceous, smooth along posterior margin, posterior margin not extended over anterior margin of metanotum laterally. Metanotum with a line of alveoli anteriorly. Propodeum laterad of median carina lightly reticulate, shiny and smooth to the step-like plica, median carina distinctly raised above surface, with large anterior cup-like flange which is somewhat truncated posteriorly. Area around spiracle reticulate, spiracle slightly raised and even with surface, with antero-lateral flange present, with 10–12 setae laterad and below spiracle. Petiole in dorsal view as long as wide (10:10), rugose dorsally. *Metasoma*. Ovate, about 1.5× as long as wide. Legs. Ratio of hind tibial spur 1:spur 2:tarsus 1: T2:T3:T4. 37:25:25:13:10:13. Forewing. Hyaline, about 2.5× as long as wide. Costal cell with 2 irregular rows of setae ventral-

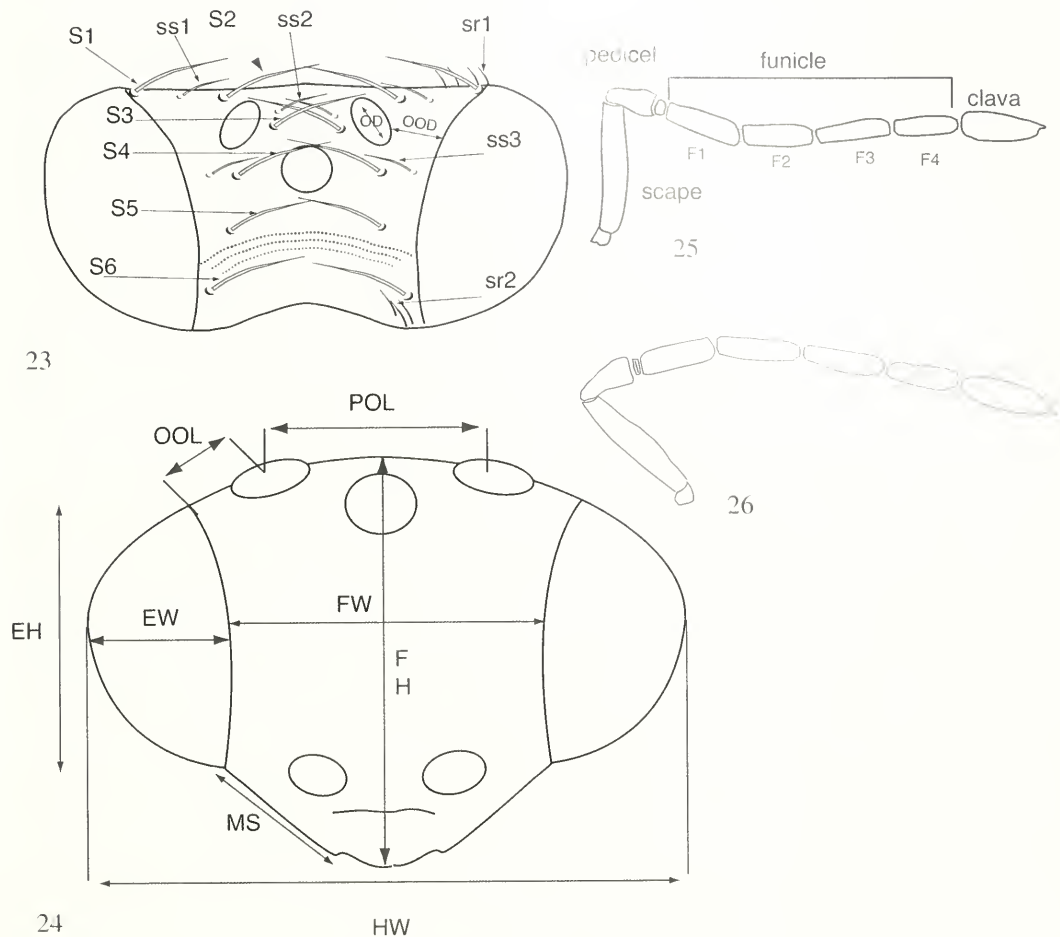

Figs. 23-26. *Euplectrus* morphology. 23, Head in dorsal view. 24, Head in frontal view. 25, Female antenna of *E. carlowae*. 26, Female antenna of *E. hansonii*. EW = eye width. EH = Eye height. FW = Face width. FH = Face height. HW = Head width. MS = Malar space. OOD = Ocell-ocular distance. OOL = Ocell-ocular length. POL = Posterior ocellar length. S1-6 = Major setae 1 to 6. sr = setal row. ss = small setae. OD = ocellar diameter.

ly. Venation yellowish, ratio of postmarginal: stigmal 32:25.

*Male*.—Similar to female except: scape yellow to white and slightly swollen apically (Fig. 39) with two irregular rows of sensillae running about 2/3 length; legs generally yellow; metasoma darker, nearly black in posterior half both dorsally and ventrally; funicle ratio 11:11:11:10:15, width 4-6 with no noticeable brown setae.

Since the male of this species was not reared with the associated females, I cannot be absolutely positive of the relation-

ship. However, all the specimens were collected at the same locality at the same time and although other species were also present in those collections, this male matches the females of this species much more closely, and we are sufficiently confident of the association to assign it to this species.

*Hosts*.—Unknown

*Distribution*.—Costa Rica.

*Types*.—Holotype female with data: "Costa Rica, San José, Zurquí de Moravia, 1600m, IV.1995, P. Hanson", (deposited in

INBIO). Paratypes: 10 females and 1 male with same data except 2 collected in January 1996 (deposited in USNM and BMNH).

*Etymology.*—This species is named in honor of Edith López Lara in special recognition of her dedicated attention to the Research Center and Dormitories in Sector Santa Rosa of the Area de Conservación Guanacaste.

*Euplectrus floryae* Schauff, new species  
(Figs. 10, 12, 28, 45–48)

*Diagnosis.*—Face below and between toruli yellow, extending up side of eye to midpoint and around face to gena and mouth (Fig. 12); two pairs of small setae (ss2) between lateral ocelli (Fig. 66); mesoscutal midlobe with 1–2 small setae anteriorly (Fig. 48), median carina complete; scutellum heavily reticulate to alutaceous; petiole in dorsal view as long as wide and rugose dorsally with irregular longitudinal carina. Male antennal scape white, slightly swollen, with narrowly ovate sensory area containing 2–3 irregular rows of sensillae extending about 3/4 length (Fig. 28), F1 slightly shorter than club.

The coloration of the face with yellow running up the side of the eyes makes this species quite distinctive among Costa Rican species. In addition, two pairs of small setae between the lateral ocelli and small setae on the anterior mesoscutal midlobe distinguish it from similar species treated here. This species is similar to *Euplectrus maculiventris* Westwood which is widespread in Canada and the U.S. and which may occur in Central America. *E. maculiventris* has the face yellow with the yellow extending up the side of the eyes. However, *E. maculiventris* has the median carina on the scutum nearly absent and the antenna of the male has the scape more enlarged and with 5–6 rows of sensillae, and the funicles are elongate and each is covered by elongate setae.

*Description.*—Female. Body length 2.1–2.3 mm. Color: body mostly black except

the following: face below and between toruli yellow, extending laterad of toruli over gena, down to mouth, and up edge of eye to near midpoint (Fig. 12); antenna with scape white to light yellow, flagellum yellow or light brown; mandibles yellow to white; legs light yellow to white; dorsal metasoma with large central yellow to white area extending from just behind petiole posteriorly over entire length of dorsum, becoming slightly darker posteriorly, lateral brown margin reduced to two brown spots separated medially by yellow and ending well before posterior margin, ventral metasoma yellow to white. *Head.* Dorsally with two pair of minor setae ss2 between posterior ocelli (as in Fig. 46), inserted adjacent to occipital carina, setae S1–6 present (as in Fig. 23), setal row sr2 present as 1–2 irregular rows of 12–16 setae, reaching the bottom of the eye. Occipital carina strongly present over entire length of occiput. Width of eye: width of face 13:35, posterior margin of eye nearly contiguous with posterior margin of head of most of length. Ratio of MS:EH 17:31, lateral ocellus more than 1 diameter from eye (OD:OOD 6:8). Face below eyes rounded, not abruptly narrowing. Vertex below anterior ocellus reticulate to alutaceous. Toruli separated by about 2–2.2× their own diameters. Malar suture absent. Area under eye lightly reticulate to smooth (difficult to assess because of yellow coloration). Scape 5× as long as wide. Ratio of funicular segments 14:12:12:13:17, width 5 at F1 to 6 at club, flagellar segments with small indistinct whorls of brown setae basally. *Mesosoma.* Pronotum anterior to transverse carina with scattered setae, finely rugosely reticulate, posterior to carina more openly reticulate and shiny. Mesoscutum (Fig. 48) reticulate, becoming more smooth, and shiny posteriorly. Midlobe with median carina well defined, fading only at extreme anterior margin, otherwise complete, slightly sunken posteriorly, with one or two small setae antero-laterally, posterior setae even with

surface or slightly raised. Dorsal axillar/scutellar margin with broad, curved deep furrow with flat bottom. Axillae shiny, openly reticulate. Scutellum shiny and lightly reticulate to alutaceous. Metanotum bordered anteriorly by a narrow band of small alveoli, medially shiny and lightly reticulate. Propodeum laterad of median carina shiny and openly reticulate to the step-like plica, median carina with anterior cup-like flange rounded and invaginated. Area around spiracle finely reticulate or granulate, spiracle slightly raised above surface (Fig. 47), opening parallel to the surface of the propodeum, with antero-lateral flange large and obvious, with 10–12 setae laterad and below spiracle. Petiole in dorsal view as long as wide (10:10), rugose dorsally with irregular longitudinal carina. *Metasoma*. Ovate, about 1.5–2× as long as wide. Legs. Ratio of hind tibial spur 1:spur 2:tarsus 1:T2:T3:T4. 35:25:23:13:10:13. Forewing. Hyaline, about 2.5× as long as wide. Costal cell with 2–3 irregular rows of setae ventrally. Venation yellow to white, ratio of post-marginal: stigmal (28:18).

*Male*.—Similar to female except: body length 1.8–2mm; face white, legs white to light yellow, metasoma with central white spot only extending about 1/2 to 2/3 of length, dark brown posteriorly, laterally dark brown, sometimes interrupted medially; antenna with scape white (Fig. 45), slightly swollen, with narrowly ovate sensory area containing 2–3 irregular rows of sensillae extending about 3/4 length (Fig. 28); funicle ratios 13:12:14:12:15, width 5, without scattered or whorled semierect brown setae on each flagellomere.

*Hosts*.—*Enyo ocypte*, *Perigonia ilus*, *P. lusca*, *Aellopos fasus* (all Sphingidae).

*Distribution*.—Known only from the ACG.

*Etymology*.—This species is named in honor of Flory Granados Venegas in special recognition of her dedicated management of the main Administrative Office of the Area de Conservación Guanacaste.

*Types*.—Holotype female: "Costa Rica, Guanacaste Prov., Area de Conservación Guanacaste, Lambert N320050 E365300, 160m., III. 5. 1992, 92-SRNP-524, D. H. Janzen & W. Hallwachs. ex. *Enyo ocypte*" (deposited in INBIO). Paratypes: 3 females and 1 male all with the same data as holotype; other specimens from the ACG: 2 males with Lambert N317200 E360850, 290m., V. 3. 1994, 94-SRNP-918; 2 males with Lambert N325500 E360200, 270m., VI. 14. 1990, 90-SRNP-112; 2 females and 1 male with Lambert N313800 E359800, 300m., VIII. 4. 1993, 93-SRNP-4177, ex. *Perigonia ilus*; 1 female and 1 male with Lambert N319000 E361150, 270m., X. 11. 1992, 92-SRNP-5353; 1 female with Lambert N319500 E360650, 260m., VI. 8. 1992, 92-SRNP-1115; 1 male and 1 female with Lambert N314500 E357850, 290m., VII. 27. 1990, 90-SRNP-1522; 1 female with Lambert N314500 E357850, 290m., VI. 8. 1992, 92-SRNP-1084; 1 male with Lambert N319550 E360650, 290m., VI. 10. 1992, 92-SRNP-1112; 2 females with Lambert N314500 E357850, 290m., VIII. 5. 1992, 92-SRNP-3929; 1 male with Lambert N319100 E360900, 260m., V. 25. 1992, 92-SRNP-831; 1 female with Lambert N314500 E357850, 240m., VII. 21. 1993, 93-SRNP-2502, ex. *Perigonia lusca*; 1 male with Lambert N315700 E354400, 300m., VI. 6. 1992, 92-SRNP-1009; 1 female with Lambert N315500 E360200, 300m., VII. 23. 1991, 91-SRNP-1792, ex. *Perigonia ilus*; 1 male with Lambert N319000 E361150, 270m., II. 2. 1992, 92-SRNP-293, ex. *Aellopos fadus*; 1 female with Lambert N314800 E360500, 300m., VII. 23. 1984, 84-SRNP-1479; 1 male and 1 female with Lambert N314650 E361300, 270m., XI. 20. 1993, 93-SRNP-7708 ex. *Perigonia ilus*; 3 males with Lambert N313100 E359900, 250m., VIII. 24. 1990, 90-SRNP-1946; 1 female with Lambert N319100 E360900, 260m., VII. 13. 1992, 92-SRNP-2642; 1 female with Lambert N312300 E360950, 260m., VI. 12. 1992, 92-SRNP-1073; 1 female with Lambert N314500 E357850, 290m., V. 26. 1991, 91-

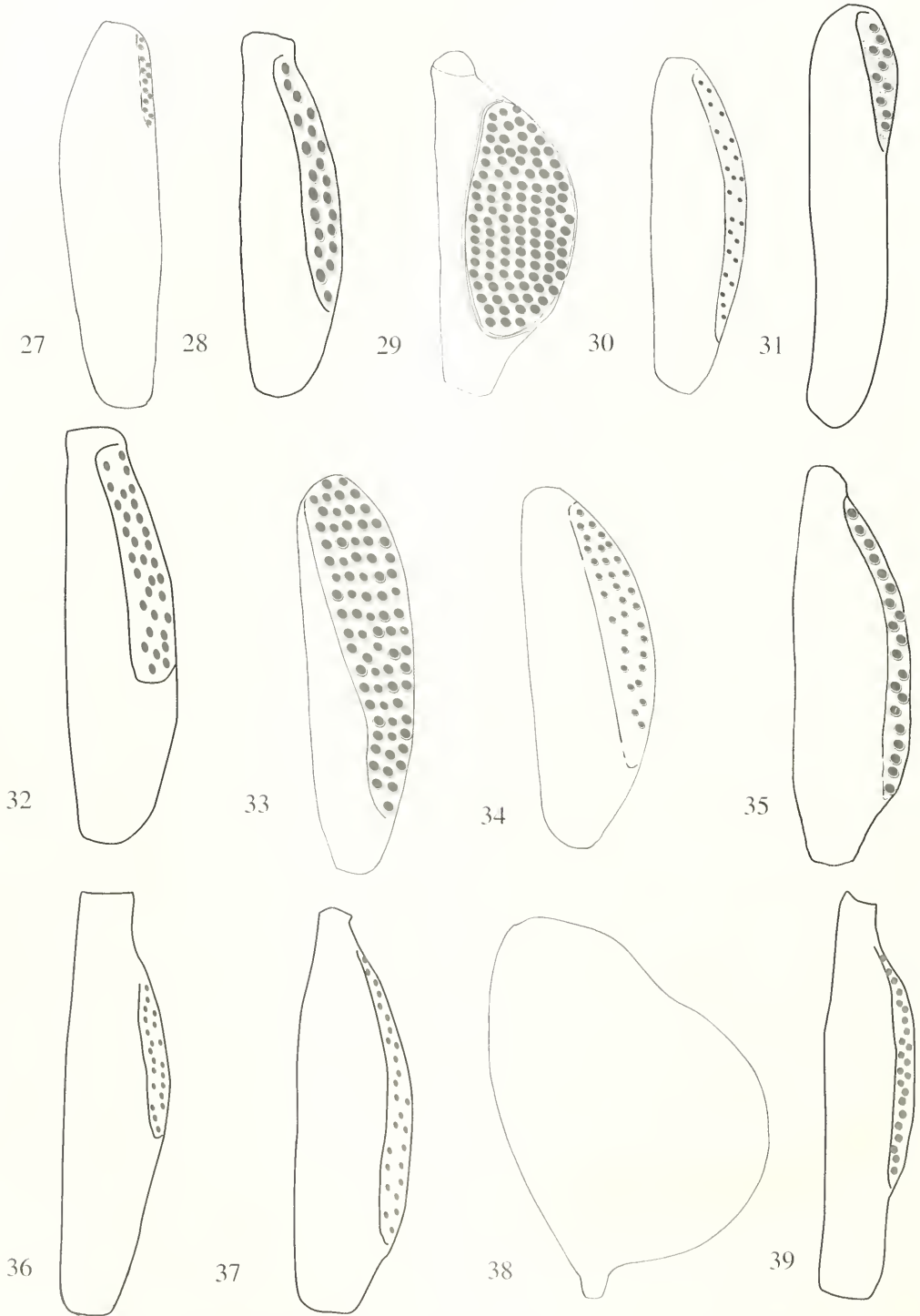

Figs. 27–39. *Euplectrus* male scapes. 27, *E. comstockii*. 28, *E. floryae*. 29, *E. walteri*. 30, *E. mariaae*. 31, *E. romici*. 32, *E. ivomae*. 33, *E. magdae*. 34, *E. anaee*. 35, *E. josei*. 36, *E. xiomarae*. 37, *E. orias*. 38, *E. valverdei*. 39, *E. edithae*.

SRNP-328; 2 males with Lambert N319000 E361150, 270m., V. 10. 1994, 94-SRNP-935; 1 female with Lambert N313800 E359800, 300m., VI. 19. 1988, 88-SRNP-229, ex. *Perigonia ilus*; 1 female with Lambert N314800 E360500, 300m., VIII. 12. 1991, 91-SRNP-2479, ex. *Perigonia ilus*; 2 males with Lambert N314500 E357850, 290m., V. 28. 1991, 91-SRNP-248; 1 female with Lambert N313100 E359900, 250m., VII. 4. 1982, 82-SRNP-368, ex. *Perigonia ilus*; 1 female with Lambert N313800 E359800, 300m., VII. 28. 1984, 84-SRNP-1501 ex. *Cautethia spuria*; 1 male with Lambert N315500 E360200, 300m., VII. 15. 1991, 91-SRNP-1512, ex. *Perigonia ilus*; 1 female with Lambert N314800 E360500, 300m., VIII. 13. 1992, 92-SRNP-3473; 1 female with Lambert N317200 E360850, 290m., V. 28. 1991, 91-SRNP-280; 1 female with Lambert N317200 E360850, 290m., V. 27. 1991, 91-SRNP-278; 1 female with Lambert N317200 E360850, 290m., V. 27. 1991, 91-SRNP-277 (deposited in USNM, BMNH, and CNC).

### *Euplectrus furnius* Walker

(Figs. 49, 50)

*Euplectrus furnius* Walker 1843:48.

*Pachyscapa insularis* Howard 1897:159. (Synonymy by Bouček 1977; see also Bouček in Desantis 1979).

**Diagnosis.**—Apical flagellar segments generally darker than F1 (as in Fig. 22); legs yellow; face below toruli dark brown to black; with no small setae between posterior ocelli (Fig. 49); width of face nearly 4× width of eye; posterior ocellus 2× its diameter from eye margin; scutellum nearly smooth, shiny, with some light reticulation; petiole wider than long; postmarginal vein barely longer than stigmal (25:20). Male antenna with scape dark brown, greatly enlarged (Fig. 50), and uniformly covered with sensillae, with funicular segments quadrate and F3 and 4 dark brown contrasting with F1 and 2 which are yellow.

*Euplectrus furnius* is a distinctive species easily recognized by the dark, broad face, with ocelli 2 diameters removed from the eye, gradually darkening antennal flagellum in the female (even more marked in the males) and short postmarginal vein. The dark, greatly swollen scape of the male is also quite distinctive. Although other species of *Euplectrus* are known to have similar scapes, none of those treated in this study have a swollen scape that is also dark colored.

**Hosts.**—The following records are primarily drawn from the literature (Burks 1979, Noyes 1998). In a few instances they have been verified from specimen label data in collections (USNM, CNC). Hosts include *Agrius cingulatus* (Sphingidae); *Antichloris eriphia* (Arctiidae); *Hadena luteago*; *Helicoverpa zea*; *Lamprosema indicata*; *Pseudoplusia includens*; *Rachisplusia nu*; *Spodoptera eridania*; *S. frugiperda* (Noctuidae).

**Distribution.**—Known from Mexico south to Ecuador and Venezuela and west to the West Indies.

**Types.**—The lectotype of *E. furnius* is in The Natural History Museum London (examined). Lectotype and paralectotypes of *E. insularis* are in the USNM (examined).

### *Euplectrus hansonii* Schauff, new species (Fig. 26)

**Diagnosis.**—Face yellow below toruli (as in Fig. 13), legs yellow; one pair of setae ss2 between lateral ocelli; F1–4 all about 3× as long as wide and nearly equal to club (Fig. 26), flagellum dark brown; postmarginal more than 2× stigmal (see Fig. 18).

This species is most easily distinguished by the elongate and dark brown funicle segments (F1–4 about 3× as long as wide and F1–3 nearly as long as club). In *E. walteri* in which F1 is also almost as long as the club, the funiculars are only about 2× as long as wide and the segments are yellow or light brown colored. In addition, the long postmarginal vein (more than 2× as long as the stigmal) is longer than in

the other species where it is usually  $2\times$  as long as the stigmal or less.

*Description.*—Female. Body length 2.2–2.6 mm. Color: body mostly black except the following: antenna with scape yellow to brown, flagellum dark brown; mandibles yellow; enlarged setae on vertex yellow to dark brown; legs yellow; dorsal metasoma dark brown to black behind petiole with yellow spot medially, posterior half dark brown, ventral metasoma dark brown behind petiole, then yellow up to about midpoint, then dark brown. *Head.* Dorsally with 2 minor seta ss2 between posterior ocelli (as in Fig. 23), all setae S1–6 present, setal row sr2 present as 2 irregular rows of about 8 setae reaching to bottom of eye; occipital carina obvious medially; width of eye: width of face (36:13), posterior margin eye of not nearly contiguous with posterior margin of head over most of length. Ratio of MS:EH 18:30; lateral ocellus more than 1 diameter from eye (OD:OOD 6:9). Face below eyes rounded, not abruptly narrowing. Vertex under anterior ocellus reticulate. Toruli separated by about  $2\times$  their own diameters. Malar suture absent. Area under eye lightly reticulate. Scape  $5\times$  as long as wide. Ratio of funicular segments 19:19:19:17:21, width 6 at F1 to 7 at club, flagellar segments with small whorls of brown setae basally. *Mesosoma.* Pronotum anterior to transverse carina with scattered setae, finely rugosely reticulate, posterior to carina reticulate and shiny. Mesoscutum reticulate, becoming more open, smooth, and shiny posteriorly. Midlobe with median carina fading in anterior  $1/4$ , not noticeably sunken posteriorly, with no small setae antero-laterally, posterior setae even with surface. Dorsal axillar/scutellar margin with broad, distinctly curved deep furrow with flat bottom. Axillae openly reticulate. Scutellum reticulate to alutaceous, smooth along posterior margin, posterior margin not extended over anterior margin of metanotum laterally. Metanotum with a very thin line of alveoli anteriorly. Pro-

podeum laterad of median carina lightly reticulate, shiny and smooth to the step-like plica, median carina distinctly raised above surface, with large anterior cup-like flange which is somewhat truncated posteriorly. Area around spiracle reticulate, spiracle slightly raised and even with surface, with antero-lateral flange present, with 6–7 setae laterad and below spiracle. Petiole in dorsal view longer than wide (14:10), rugose dorsally. *Metasoma.* Ovate, about  $1.5\times$  as long as wide. Legs. Ratio of hind tibial spur 1:spur 2:tarsus 1:T2:T3:T4. 40:25:22:17:12:16. Forewing. Hyaline, about  $2.4\times$  as long as wide. Costal cell with 2 irregular rows of setae ventrally. Venation yellowish, ratio of postmarginal:stigmal (50:23).

*Male.*—Unknown.

*Hosts.*—Unknown.

*Distribution.*—Known only from the type locality.

*Types.*—Holotype female, deposited in USNM, with data: "Costa Rica, San Jose, Zurqui de Moravia, 1600m, IX.1996, P. Hanson". Paratype female with same data deposited in USNM.

*Etymology.*—This species is named for the collector of the types, Paul Hanson, who also contributed many other interesting specimens to this study.

### *Euplectrus ireneae* Schauff, new species (Figs. 14, 51)

*Diagnosis.*—Face below and between toruli yellowish brown, lighter than above toruli; legs light yellow to white; width of eye more than half width of face (Fig. 14), lateral ocellus less than 1 diameter from eye; with 1 pair of setae (ss2) between lateral ocelli; setal row sr2 present as 1–2 irregular rows of 5–12 setae usually not reaching the bottom of the eye.

The structure of the head with the lateral ocellus less than 1 diameter from the eye and the eye itself more than half the width of the face (frontal view) make this species easily recognizable from all other species treated.

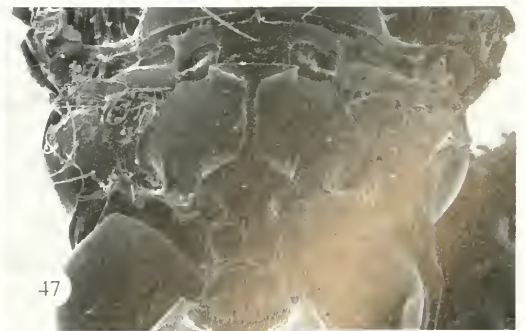
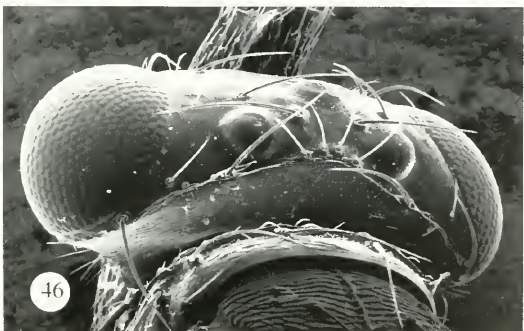
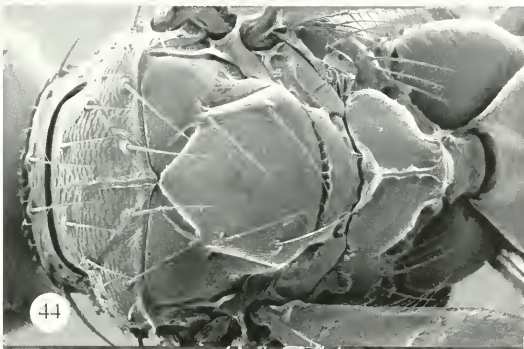

Figs. 40–47. *Euplectrus* scanning electron micrographs. 40–42, *E. anae*. 40, Propodeum. 41, Male antennae. 42, Mesosoma. 43, *E. carlowae*, Scutellum and propodeum. 44, *E. comstockii*, mesosoma. 45–47, *E. floryae*. 45, Male scape. 46, Head, dorsal view. 47, Propodeum.

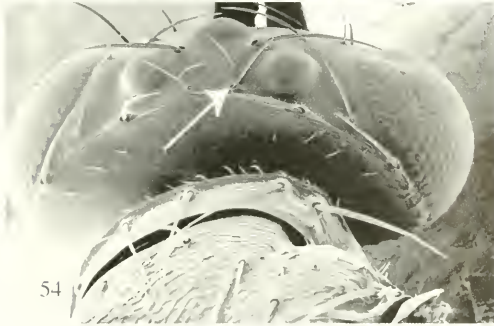
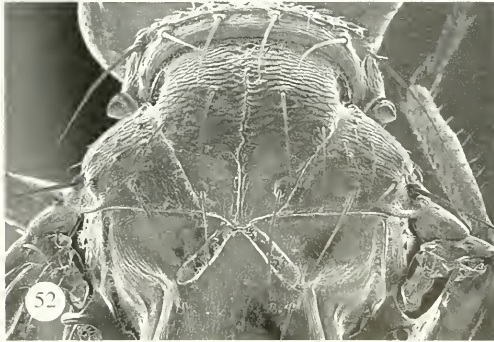
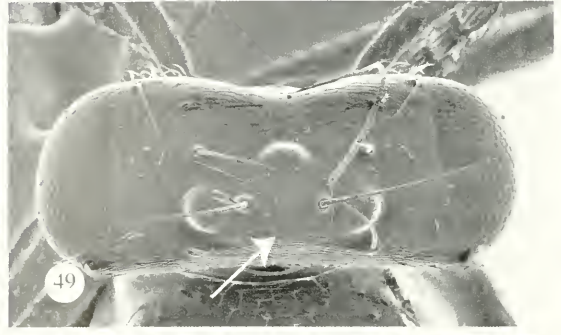
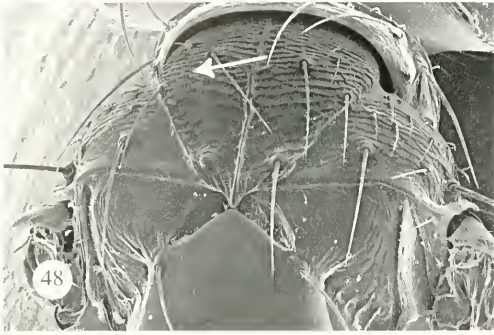

Figs. 48–55. *Euplectrus* scanning electron micrographs. 48, *E. floryae*, dorsal mesosoma. 49–50, *E. furnius*. 49, Head, dorsal view. 50, Male scape. 51, *E. irenae*, propodeum. 52–53, *E. ivonae*. 52, Dorsal mesosoma. 53, Propodeum. 54–55, *E. josei*. 54, Head, dorsal view. 55, Dorsal mesosoma.

*Description.*—Female. Body length 2.3–2.6 mm. Color: body mostly black except the following: face below and between toruli yellowish brown; antenna with scape white to light yellow, flagellum yellow; mandibles yellow; legs light yellow to white; dorsal metasoma with large central yellow area extending from just behind petiole posteriorly for about 1/2 length, and extending laterally around the side of the metasoma, posteriorly dark brown, ventral metasoma yellow. *Head.* Dorsally with one pair of minor seta ss2 between posterior ocelli (as in Fig. 70), inserted distinctly above occipital carina, all setae S1–6 present, setal row sr2 present as 1–2 irregular rows of 5–12 setae usually not reaching the bottom of the eye; occipital carina present medially; width of eye: width of face 17:30, posterior margin eye of contiguous with posterior margin of head of most of length. Ratio of MS:EH 13:36; lateral ocellus less than 1 diameter from eye (OD:OOD 12:5). Face below eyes rounded, not abruptly narrowing. Vertex under anterior ocellus lightly reticulate. Toruli separated by about 2–2.5× their own diameters. Malar suture absent. Area under eye lightly reticulate. Scape 5× as long as wide. Ratio of funicular segments 16:15:16:16:20, width 6 at F1 to 8 at club. *Mesosoma.* Pronotum anterior to transverse carina with scattered setae, finely rugosely reticulate, posterior to carina more openly reticulate and shiny. Mesoscutum reticulate in anterior 1/2, becoming more smooth, and shiny posteriorly with slight reticulation. Midlobe with median carina fading only at extreme anterior margin, otherwise complete, not sunken posteriorly, with no small setae antero-laterally, posterior setae even with surface. Dorsal axillar/scutellar margin with broad, slightly curved, deep furrow with flat bottom. Axillae shiny, openly reticulate, becoming nearly smooth at posterior margin. Scutellum finely reticulate to alutaceous, shiny, slightly pointed at anterior margin with axillae. Metanotum not bor-

dered anteriorly and medially by small alveoli, medially flat and shiny and very lightly reticulate without median carina below. Propodeum laterad of median carina nearly smooth (lightly reticulate) laterally to the step-like plica, median carina with anterior cup-like flange rounded and invaginated. Area around spiracle finely reticulate, lateral edge of spiracle raised above surface (Fig. 51), with antero-lateral flange large and well defined, with 7–8 setae laterad and below spiracle. Posterior margin of propodeum without irregular alveolae and carinae. Petiole in dorsal view slightly wider than long (14:13) and rugose dorsally, becoming smooth at posterior margin. *Metasoma.* Ovate, about 1.5X as long as wide, with brown margin laterally interrupted by yellow about midpoint making the yellow area appear as an inverted “T” shape, ventrally light yellow to white, becoming dark yellow posteriorly. Legs. Ratio of hind tibial spur 1:spur 2:tarsus 1:T2:T3:T4. 35:28:20:17:11:19. Forewing. Hyaline, about 2.2× as long as wide. Costal cell with 1 and occasionally a partial second irregular row of setae ventrally. Venation yellow to white, ratio of postmarginal: stigmal (29:20).

*Male.*—Unknown.

*Hosts.*—*Motyia abseuzalis* (Noctuidae).

*Distribution.*—Known only from the type locality.

*Types.*—Holotype female: Costa Rica, Guanacaste Prov., Area de Conservación Guanacaste, Lambert N309250 E353000, 2m., VII. 6, 1995, 95-SRNP-6049, D.H. Janzen & W. Hallwachs. ex. *Motyia abseuzalis* (deposited in INBIO). Paratypes: 6 females with the same data as holotype (deposited in USNM and BMNH).

*Etymology.*—This species is named in honor of Irene Carrillo Carillo in special recognition of her dedicated attention to the dining operations in Sector Santa Rosa of the Area de Conservación Guanacaste.

*Euplectrus ivonae* Schauff, new species  
(Figs. 16, 32, 52, 53)

*Diagnosis.*—Face below and between toruli yellow, extending laterally to near eye

and ventrally around mouth and gena (Fig. 16); legs yellow; one pair of setae ss2 between lateral ocelli; seta S5 absent; longitudinal carina on mesoscutum nearly complete, midlobe without small setae; scutellum finely longitudinally striate reticulate; metanotum bordered anteriorly and medially by small alveoli, medially expanded into a triangular flange; propodeum laterad of median carina nearly smooth (lightly reticulate) (Fig. 53); dorsal metasoma with large central yellow area extending from just behind petiole posteriorly for about 2/3 length, interrupted posteriorly by a central dark spot and becoming lighter brown again in posterior 1/4, laterally dark brown. Male. Face with white area almost touching eye laterally; legs white; antenna with scape white, slightly swollen on ventral surface, with sensory area slightly darker and with several irregular rows of sensillae extending for about 3/4 length (Fig. 32).

This species is similar to species like *magdae*, *ronnici*, and *mariae*, which lack S5 and have the face yellow. In this species, the face is more extensively yellow with the coloration extending laterad of the toruli over to and below the eyes. It does not, however, extend up the margin of the eyes as in *floryae*.

*Description.*—Female. Body length 2.25–2.5 mm. Color: body mostly black except the following: face below and between toruli yellow, extending laterally to near eye and ventrally around mouth and gena (Fig. 16); antenna with scape white to light yellow, flagellum yellow to light brown; mandibles yellow; legs yellow; dorsal metasoma with large central yellow area extending from just behind petiole posteriorly for about 2/3 length, interrupted posteriorly by a central dark spot and becoming lighter brown again in posterior 1/4, laterally dark brown; ventral metasoma yellow. *Head.* Dorsally with one pair of minor seta ss2 inserted near occipital carina between posterior ocelli (as in Fig. 70), seta S5 absent, setal row sr2 present

as 2–3 irregular rows of 12–18 setae reaching the bottom of the eye; occipital carina present medially; width of eye: width of face 12:38, posterior margin of eye separated from margin of head ventrally. Ratio of MS:EH 18:30; lateral ocellus more than 1 diameter from eye (OD:OOD 13:10). Face below eyes rounded, not abruptly narrowing. Vertex under anterior ocellus reticulate. Toruli separated by about 2× their own diameters. Malar suture absent. Area under eye irregularly reticulate to alutaceous. Scape 6× as long as wide. Ratio of funicular segments 13:13:14:14:18, width 7 at F1 to 8 at F4. *Mesosoma.* Pronotum anterior to transverse carina with scattered setae, finely rugosely reticulate, posterior of carina more openly reticulate and shiny. Mesoscutum (Fig. 52) rugose reticulate in anterior 1/2, becoming more smooth and shiny posteriorly with slight reticulation. Midlobe with median carina fading only at extreme anterior margin, otherwise complete, slightly sunken posteriorly, with no small setae antero-laterally, posterior setae raised above surface on small tubercle. Dorsal axillar/scutellar margin with broad, nearly straight deep furrow with narrow but flat bottom. Axillae shiny, openly reticulate, becoming smooth at posterior margin. Scutellum finely longitudinally striate reticulate, pointed anteriorly at axillar margin. Metanotum bordered anteriorly and medially by small alveoli, medially expanded into a triangular flange (Fig. 53) with median carina below. Propodeum laterad of median carina nearly smooth (lightly reticulate) laterally to the step-like plica, median carina with anterior cup-like flange rounded and deeply invaginated. Area around spiracle finely reticulate, lateral edge of spiracle raised above surface, with antero-lateral flange large and well defined, with 9–10 setae laterad and below spiracle. Posterior margin of propodeum without irregular alveolae and carinae. Petiole in dorsal view wider than long (17:10) and rugose dorsally becoming smooth at pos-

terior margin. *Metasoma*. Ovate, about 1.5× as long as wide, with brown margin laterally interrupted by yellow about mid-point making the yellow area appear as an inverted "T" shape. Legs. Ratio of hind tibial spur 1:spur 2:tarsus 1:T2:T3:T4. 41:30:30:17:7:17. Forewing. Hyaline, about 2.2× as long as wide. Costal cell with 2 irregular rows of setae ventrally. Venation yellow to white, ratio of postmarginal: stigmal (27:18).

*Male*.—Similar to female except: body length 1.9 mm. Face with white area almost touching eye laterally; legs white; dorsal metasoma with large central white spot, dark brown posteriorly; antenna with scape white, slightly swollen on ventral surface, with sensory area slightly darker and with several irregular rows of sensillae extending for about 3/4 length (Fig. 32); funicle ratios 13:13:14:13:18, width about 6 anteriorly to 7 posteriorly, with numerous semierect brown setae on each flagellomere.

*Hosts*.—*Euscirrhopterus poeyi* (Noctuidae).

*Distribution*.—Known only from the type locality.

*Types*.—Holotype female: Costa Rica, Guanacaste Prov., Area de Conservación Guanacaste, Lambert N313800 E359800, 300m., V. 21, 1994, 94-SRNP-1656, D.H. Janzen & W. Hallwachs. ex. *Euscirrhopterus poeyi* (deposited in INBIO). Paratypes: 6 females and 1 male with same data as holotype (deposited in USNM).

*Etymology*.—This species is named in honor of Ivon Traña Medrano in special recognition of her dedicated attention to the dining operations in Sector Santa Rosa of the Area de Conservación Guanacaste.

***Euplectrus josei* Schauff, new species**  
(Figs. 35, 54–57)

*Diagnosis*.—Face below and between toruli yellow; dorsally with two pairs of minor seta ss2 between posterior ocelli (Fig. 54); posterior margin of eye nearly contiguous with posterior margin of head over

most of length. Male antenna with scape white, slightly swollen (Fig. 57), with narrow, elongate sensory area containing 2 irregular rows of sensillae extending almost entire length (Fig. 35).

This species is recognizable by two characters: 2 pairs of setae between the lateral ocelli (ss2) and the posterior margin of the eye contiguous with the posterior margin of the head. *Euplectrus floryae* also has two pairs of ss2 setae, but the yellow color on the face runs to and partially up the margin of the eyes whereas in *josei* it is restricted to between and below the toruli.

*Description*.—Female. Body length 2.2–2.5 mm. Color: body mostly black except the following: face below and between toruli yellow; antenna with scape white to light yellow, flagellum yellow; mandibles yellow; legs light yellow to white; dorsal metasoma with large central yellow to white area extending from just behind petiole posteriorly about 1/2–2/3 length of dorsum, becoming darker brown posteriorly, lateral margin brown anteriorly, then yellow medially and becoming dark brown posteriorly; ventral metasoma yellow to white. *Head*. Dorsally with two pairs of minor seta ss2 between posterior ocelli, inserted adjacent to occipital carina (Fig. 54), all setae S1–6 present, setal row sr2 present as 1–2 irregular rows of 12–15 setae reaching the bottom of the eye; occipital carina weak medially; width of eye: width of face: 35:15, posterior margin eye of nearly contiguous with posterior margin of head over most of length. Ratio of MS:EH 13:33; lateral ocellus less than 1 diameter from eye (OD:OOD 8:5). Face below eyes rounded, not abruptly narrowing. Vertex under anterior ocellus reticulate to alutaceous. Toruli separated by about 2× their own diameters. Malar suture absent below eye. Area under eye lightly reticulate to alutaceous. Scape 4× as long as wide. Ratio of funicular segments 13:13:13:12:19, width 7 at F1 to 8 at club, flagellar segments without small

whorls of brown setae basally. *Mesosoma*. Pronotum anterior to transverse carina with scattered setae, finely rugosely reticulate, posterior to carina more openly reticulate and shiny. Mesoscutum (Fig. 55) reticulate, becoming more smooth, and shiny posteriorly. Midlobe with median carina fading over anterior 1/4, otherwise complete, slightly sunken posteriorly, with no small setae antero-laterally, posterior setae even with surface. Dorsal axillar/scutellar margin with broad, nearly straight deep furrow with flat bottom. Axillae shiny, openly reticulate. Scutellum reticulate to alutaceous, smooth along posterior margin, slightly pointed at anterior margin with axillae. Metanotum bordered anteriorly by narrow band of small alveoli, medially shiny and lightly reticulate with anterior edge slightly projected outward. Propodeum laterad of median carina shiny and smooth to very lightly reticulate to the step-like plica, median carina with anterior cup-like flange nearly triangular, slightly invaginated. Area around spiracle reticulate, openly reticulate laterally, spiracle slightly raised above surface and slanted so that opening is at a slight angle to the surface (Fig. 56), with antero-lateral flange present and obvious, with 8–12 setae laterad and below spiracle. Posterior margin of propodeum with a deep alveolus at posterior margin adjacent to plica. Petiole in dorsal view slightly longer than wide (11:10), rugose dorsally with irregular longitudinal carina and smooth at posterior margin. *Metasoma*. Ovate, about 1.5–2× as long as wide. Legs. Ratio of hind tibial spur 1:spur 2:tarsus 1:T2:T3:T4. 34:25:23:16:10:15. Forewing. Hyaline, about 2.3× as long as wide. Costal cell with 2 irregular rows of setae ventrally. Venation yellow to white, ratio of post-marginal: stigmal (30:18).

*Male*.—Similar to female except: Body length 2.25 mm. Antenna with scape white, (Figs. 35, 57) slightly swollen, with narrow, elongate sensory area containing 2 irregular rows of sensillae extending al-

most entire length; funicle ratios 14:14:14:14:20 width 6–7, with scattered or whorled semierect brown setae on each flagellomere.

*Hosts*.—*Pacctes lmodes* (Noctuidae).

*Distribution*.—Known only from the ACG.

*Types*.—Holotype female: Costa Rica, Guanacaste Prov., Area de Conservación Guanacaste, Lambert N314800 E360500, 300m., VII. 8, 1993, 93-SRNP-3064, D.H. Janzen & W. Hallwachs. ex. *Pacctes lmodes* (deposited in INBIO). Paratypes: 2 males with the same data as holotype; other specimens with some of the same information as holotype are except: 2 females with Lambert N313800 E359800, 300m., VII. 17. 1984, 84-SRNP-1504; 2 males and 1 female with Lambert N313800 E359800, 300m., VII. 18. 1984, 84-SRNP-1433; 2 females with Lambert N314800 E360500, 300m., VII. 6. 1993, 93-SRNP-2869; 1 male and 1 female with Lambert N313800 E359800, 300m., VII. 4. 1993, 93-SRNP-2871; 1 male with Lambert N314800 E360500, 300m., VII.7.1993, 93-SRNP-3093; 2 males and one female with Lambert N314400 E358900, 280m., VII.4.1995, 95-SRNP-6055 (deposited in USNM, BMNH, and CNC).

*Etymology*.—This species is named in honor of José Eras Pineda in special recognition of his dedicated management of the dining operations in Sector Santa Rosa of the Area de Conservación Guanacaste.

*Euplectrus magdae* Schauff, new species  
(Figs. 33, 58–60)

*Diagnosis*.—Face below and between toruli yellowish brown (as in Figs. 13, 14); legs light yellow to white; one pair of small setae (ss2) between lateral ocelli (as in Fig. 54); all major setae S1–6 present; metanotum bordered anteriorly by a large nearly continuous invagination sometimes divided medially into two alveoli (Fig. 59); propodeum laterad of median carina reticulate, median carina with anterior cup-like flange nearly triangular and only slightly

invaginated; petiole wider than long. Male antenna with scape white, swollen on lateral surface (Fig. 60), with sensory area invaginated and with 3–4 irregular rows of sensillae extending nearly entire length (Fig. 33).

This species is similar to *E. auae* which shares the yellow face, yellow legs, and presence of all 6 pairs of large facial setae. In *E. auae* the petiole is longer than wide while in *E. magdae* the petiole is slightly wider than long. The male scape of *E. magdae* is more swollen and sunken with a larger sensory area than in *E. auae* (Fig. 34).

*Description.*—Female. Body length 2.2–2.6 mm. Color: body mostly black except the following: face below and between toruli yellowish brown; antenna with scape white to light yellow, flagellum yellow to light brown; mandibles yellow to white; legs light yellow to white; dorsal metasoma with large central yellow area extending from just behind petiole posteriorly for about 1/2 length, roughly hourglass shaped posteriorly dark brown to black, ventral metasoma yellow in anterior half, brown posteriorly. *Head.* Dorsally with one pair of minor seta ss2 between posterior ocelli (as in Fig. 70), inserted distinctly above occipital carina, all setae S1–6 present, setal row sr2 present as 2–3 irregular rows of 20–25 setae reaching the bottom of the eye; occipital carina present medially; width of eye: width of face 14:40, posterior margin of eye separated from margin of head ventrally. Ratio of MS:EH 16:30; lateral ocellus more than 1 diameter from eye (OD:OOD 14:10). Face below eyes rounded, not abruptly narrowing. Vertex under anterior ocellus smooth to lightly reticulate. Toruli separated by about 2X their own diameters. Malar suture absent. Area under eye smooth. Scape 4X as long as wide. Ratio of funicular segments 14:14:14:14:19, width 6 at F1 to 7 at club, each flagellar segment with 1–2 irregular whorls of brown setae basally. *Mesosoma.* Pronotum anterior to transverse

carina with scattered setae, finely rugosely reticulate, posterior to carina more openly reticulate and shiny. Mesoscutum (Fig. 58) reticulate, becoming more smooth, and shiny posteriorly. Midlobe with median carina fading only at extreme anterior margin, otherwise complete, slightly sunken posteriorly, with no small setae antero-laterally, posterior setae even with surface. Dorsal axillar/scutellar margin with broad, curved deep furrow with flat bottom. Axillae shiny, openly reticulate. Scutellum finely reticulate to alutaceous, shiny, more nearly rounded anteriorly at margin with axillae. Metanotum bordered anteriorly by a large nearly continuous invagination sometimes divided medially into two alveoli, medially shiny and lightly reticulate, without median carina below. Propodeum (Fig. 59) laterad of median carina reticulate to the step-like plica, median carina with anterior cup-like flange nearly triangular and only slightly invaginated. Area around spiracle finely reticulate, lateral edge of spiracle raised above surface, with antero-lateral flange reduced, with 7–8 setae laterad and below spiracle. Posterior margin of propodeum without irregular alveolae and carinae. Petiole in dorsal view slightly wider than long (15:12) and rugose dorsally. *Metasoma.* Ovate, about 1.7–2× as long as wide. Legs. Ratio of hind tibial spur 1:spur 2: tarsus 1:T2:T3:T4. 40:30:27:16:11:18. Forewing. Hyaline, about 2.5× as long as wide. Costal cell with 2 irregular rows of setae ventrally. Venation yellow to white, ratio of postmarginal: stigmal (33:17).

*Male.*—Similar to female except: body length 1.9 mm. Face with white area slightly broader; legs white with distal femora, tibiae, and tarsi sometimes yellow; dorsal metasoma with large central white spot, dark brown posteriorly; antenna with scape white, (Figs. 33, 60) swollen on ventral surface, with sensory area invaginated and with 3–4 irregular rows of sensillae extending nearly entire length; funicle ratios 13:13:14:13:18, width about 6

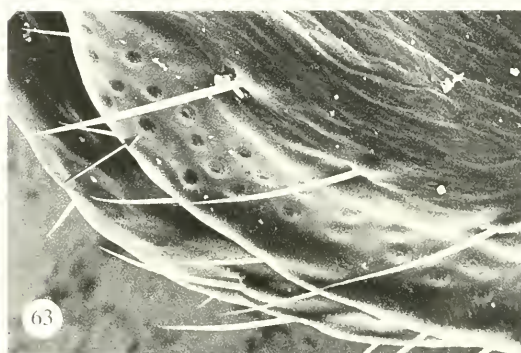

Figs. 56–63. *Euplectrus* scanning electron micrographs. 56–57, *E. josei*. 56, Propodeum. 57, Male scapes. 58–60, *E. magdae*. 58, Dorsal mesosoma. 59, Propodeum. 60, Male scapes. 61–63, *E. mariae*. 61, Dorsal mesosoma. 62, Male head and scape. 63, Closeup of male scape.

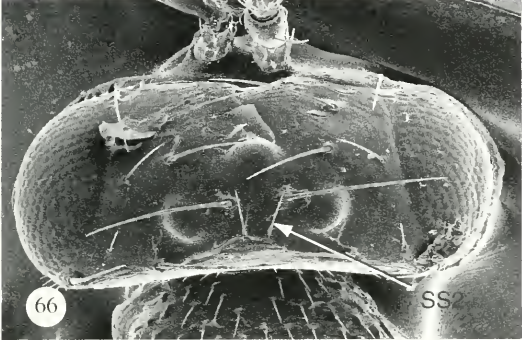

Figs. 64–71. *Euplectrus* scanning electron micrographs. 64–67, *E. orias*. 64, Dorsal mesosoma. 65, Propodeum. 66, Head, dorsal view. 67, Head, lateral view. 68–69, *E. rojasi*. 68, Dorsal mesosoma. 69, Propodeum, lateral view. 70–71, *E. romicii*. 70, Head and mesosoma. 71, Dorsal mesosoma.

anteriorly to 7 posteriorly, with whorled semi-erect brown setae on base of each flagellomere.

*Hosts*.—*Dasylophia maxtla*, *D. basitincta*, *D. nr. goraxa* (all Notodontidae).

*Distribution*.—Known only from the ACG.

*Types*.—Holotype female: Costa Rica Guanacaste Prov., Area de Conservación Guanacaste, Lambert N318600 E375150, 560m., IX.12.1995, 95-SRNP-9001, ex. *Dasylophia maxtla*, D.H. Janzen & W. Hallwachs (deposited in INBIO). Paratypes: 5 males and 25 females with same data as holotype (deposited in USNM, BMNH, CNC).

*Other specimens examined*.—All from the ACG, 4 specimens 94-SRNP-6167, ex. *Chliara croesus*; 4 specimens 96-SRNP-11096; 1 specimen 93-SRNP-2905, ex. *Dasylophia basitincta*, 4 specimens 87-SRNP-1302, ex. *Dasylophia not basitincta*.

*Etymology*.—This species is named in honor of María Magdalena Rodríguez Rodríguez in special recognition of her dedicated management of the main Administrative Office of the Area de Conservación Guanacaste.

***Euplectrus mariae* Schauff, new species**  
(Figs. 30, 61–63)

*Diagnosis*.—Face below and between toruli yellow, extending slightly laterad of toruli, but not reaching eye (as in Fig. 13); one pair of setae ss2 between posterior ocelli, seta S5 absent (see Fig. 23); mesoscutal midlobe without small setae anteriorly; propodeum (Fig. 61) lightly reticulate, often with irregular carinae laterad of median carina and appearing somewhat rugose; petiole in dorsal view wider than long. Male antenna with scape white, slightly swollen, with brown, elongate narrowly ovate sensory area containing 2–3 irregular rows of sensillae extending about 2/3 length (Fig. 30).

This species is very similar to *E. ronniei* which also has a yellow face and lacks seta S5. *Euplectrus mariae* can be distinguished

from *ronniei* by the petiole which is as wide as long in that species, but wider than long in *magdae*. The male scape of *ronniei* has the small brown sensory area much shorter (Fig. 31) and with only a single row of sensillae while in *mariae* the sensory area is long and with at least two irregular rows of sensillae (Figs. 30, 62, 63).

*Description*.—Female. Body length 2.1–2.3 mm. Color: body mostly black except the following: face below and between toruli yellow, extending slightly laterad of toruli but not reaching eye; antenna with scape white to light yellow, flagellum yellow or light brown; mandibles yellow to white; legs light yellow to white; dorsal metasoma with large central yellow to white area extending from just behind petiole posteriorly about 2/3 to 3/4 length of dorsum, becoming slightly darker posteriorly, lateral brown margin continuous over length, ventral metasoma yellow to white. *Head*. Dorsally with one pair of minor seta ss2 between posterior ocelli, seta S5 absent, setal row sr2 present as 1–3 irregular rows of 20–25 setae reaching the bottom of the eye; occipital carina fading medially; width of eye: width of face 11:33, posterior margin eye of nearly contiguous with posterior margin of head most of length; ratio of MS:EH 15:30; lateral ocellus more than 1 diameter from eye (OD:OOD 6:8). Face below eyes rounded, not abruptly narrowing. Vertex under anterior ocellus reticulate. Toruli separated by about 2× their own diameters. Malar suture absent. Area under eye lightly reticulate. Scape 6× as long as wide. Ratio of funicular segments 12:12:12:13:17, width 6 at F1 to 7 at club, flagellar segments without small whorls of brown setae basally. *Mesosoma*. Pronotum anterior to transverse carina with scattered setae, finely rugosely reticulate, posterior to carina more openly reticulate and shiny. Mesoscutum (Fig. 61) reticulate, becoming more smooth, and shiny posteriorly. Midlobe with median carina fading over an-

terior 1/4, otherwise complete, slightly sunken posteriorly, with no small setae antero-laterally, posterior setae even with surface or slightly raised. Dorsal axillar/scutellar margin with broad, nearly straight deep furrow with narrow, but flat bottom. Axillae shiny, openly reticulate. Scutellum shiny and lightly reticulate to alutaceous, pointed at anterior margin. Metanotum bordered anteriorly by a narrow band of small alveoli, medially shiny and lightly reticulate. Propodeum laterad of median carina shiny and openly reticulate to the step-like plica, median carina with anterior cup-like flange rounded and invaginated. Area around spiracle granulate medially, openly reticulate laterally, spiracle slightly raised above surface parallel to the surface of the propodeum, with antero-lateral flange large and obvious, with 8–9 setae laterad and below spiracle. Petiole in dorsal wider than long (20:15) and rugose dorsally with irregular longitudinal carina and smooth at posterior margin. *Metasoma*. Ovate, about 1.5–2× as long as wide. Legs. Ratio of hind tibial spur 1:spur 2:tarsus 1:T2:T3:T4. 32:25:18:14:8:20. Forewing. Hyaline, about 2.3× as long as wide. Costal cell with 2 irregular rows of setae ventrally. Venation yellow to white, ratio of postmarginal: stigmal (32:18).

*Male*.—Similar to female except: Body length 1.7–1.9 mm. Face yellow to white, legs white to light yellow, metasoma with central white spot extending only about 1/2 to 2/3 of length, dark brown posteriorly, laterally dark brown to light brown. Antenna (Figs. 30, 62, 63) with scape white, slightly swollen, with brown, elongate narrowly ovate sensory area containing 2–3 irregular rows of sensillae extending about 2/3 length (Fig. 30); funicle ratios 11:10:11:11:16, width 6–7, without scattered or whorled semierect brown setae on each flagellomere.

*Hosts*.—*Concana Mundissima* (Noctuidae), *Elymiotis attenuata* (Notodontidae), *Dasylophia* nr. *goraxa* (Notodontidae).

*Distribution*.—Known only from Guanacaste.

*Types*.—Holotype female: Costa Rica, Guanacaste Prov., Area de Conservación Guanacaste, Lambert N309700 E352300, 5m., V. 18, 1994, 94-SRNP-1063, D.H. Janzen & W. Hallwachs. ex. *Concana mundissima* (deposited in INBIO). Paratypes: 2 females and 1 male all with the same data as holotype; other specimens with some of the same information are except: 3 males and 1 female with Lambert N316100 E360300, 310m., VI. 13. 1993, 93-SRNP-1585; 1 male and 3 females with Lambert N318500 E359850, 240m., V. 24. 1992, 92-SRNP-3032; 1 female with Lambert N309700 E352300, 5m., V. 19. 1994, 94-SRNP-1083; 2 males with Lambert N309700 E352300, 5m., V.16.1994, 94-SRNP-1075; 1 female with Lambert N309700 E352300, 5m., V.16.1994, 94-SRNP-1071; 1 female with Lambert N316100 E360300, 310m., VI.15.1993, 93-SRNP-1577; 2 males with Lambert N309700 E352300, 5m., V.19.1994, 94-SRNP-1217; 1 female with Lambert N316100 E360300, 300m., VI.14.1993, 93-SRNP-1583; 1 female with Lambert N309700 E352300, 5m., V.16.1994, 94-SRNP-1088; 1 male with Lambert N309700 E352300, 5m., V.24.1994, 94-SRNP-1216; 1 male and 1 female with Lambert N309700 E352300, 5m., V.15.1994, 94-SRNP-1055; 1 male and 1 female with Lambert N309700 E352300, 5m., V.19.1994, 94-SRNP-1160; 1 male with Lambert N309700 E352300, 5m., V.18.1994, 94-SRNP-1081; 1 male and 1 female with Lambert N309700 E352300, 5m., V.14.1994, 94-SRNP-1102; 1 female with Lambert N318500 E359850, 240m., VII.22.1992, 92-SRNP-3141; 1 male with Lambert N318500 E359850, 240m., VII.19.1992, 92-SRNP-2923; 1 female with Lambert N318500 E359850, 240m., VII.22.1992, 92-SRNP-3142; 1 male with Lambert N309700 E352300, 5m., V.18.1994, 94-SRNP-1159; 1 female with Lambert N309700 E352300, 5m., V.16.1994, 94-SRNP-1090; 1 male, 2 females with Lam-

bert N318500 E359850, 240m., VII.19.1992, 92-SRNP-2924; 1 female with Lambert N312150 E357200, 250m., VII.24.1992, 92-SRNP-3297; 1 male with Lambert N309700 E352300, 5m., V.18.1994, 94-SRNP-1093; 1 female with Lambert N318500 E359850, 240m., VII.19.1992, 92-SRNP-2924; 1 male and 1 female with Lambert N314800 E360500, 300m., VII.27.1993, 93-SRNP-3731; 1 male and 1 female with Lambert N314800 E360500, 300m., VII.23.1992, 92-SRNP-4426; 1 male with Lambert N314800 E360500, 300m., VII.23.1994, 94-SRNP-5595; 1 female with Lambert N309450 E355300, 10m., VI.5.1992, 93-SRNP-993; 2 males and 1 female with Lambert N308900 E355700, 10m., V.24.1996, 96-SRNP-1314; 1 female with Lambert N316100 E360300, 310m., VI.14.1993, 93-SRNP-1582; 1 male and 1 female with Lambert N314800 E360500, 300m., VII.19.1994, 94-SRNP-5588; 1 male with Lambert N314800 E360500, 300m., VII.31.1991, 91-SRNP-2245 (paratypes deposited in USNM, INBIO, BMNH, and CNC).

*Other specimens examined.*—3 specimens 92-SRNP-4431, ex. *Elymiotis* sp.; 2 specimens 91-SRNP-1091, ex. *Concana mundissima*.

*Etymology.*—This species is named in honor of María De Los Angeles Guevara Rojas in special recognition of her dedicated attention to the dining operations in Sector Santa Rosa of the Area de Conservación Guanacaste.

***Euplectrus orias* Schauff, new species**  
(Figs. 15, 37, 64–67)

*Diagnosis.*—Female face below toruli dark brown (Fig. 15), legs with midcoxa brown and hind coxa brown to black, hind femur brown distally; antenna with scape yellow, flagellum yellow or light brown; mandibles yellow; with one pair of minor seta ss2 between posterior ocelli (Fig. 66), malar suture present below eye (Fig. 67); petiole as wide as long.

This is one of a small group of species

with a dark face and dark hind coxae (*zamorai*, *valverdei* and *rojasi*). It can be differentiated from *zamorai*, *rojasi*, and *valverdei* by the presence of a single pair of ss2 setae between the lateral ocelli (setae absent in *zamorai*, *rojasi*, and *valverdei*). In addition, in *zamorai* the antennal flagellum has the last two segments distinctly darker than the preceding segments (segments only gradually becoming darker in *orias*). In *E. xiomarae*, which also has a dark face and hind coxae, the malar suture is absent (this suture can be difficult to assess since it is often weakly expressed so caution is urged).

*Description.*—Female. Body length 1.6–1.7 mm. Color: body mostly black except the following: face below and between toruli brown (Fig. 15); antenna with scape yellow, flagellum yellow or light brown; mandibles yellow; legs yellow-brown except midcoxa brown, hind coxa mostly dark brown to black, hind femur with distal half brown; dorsal metasoma with large central yellow area extending from just behind petiole posteriorly about 1/2 length of dorsum, becoming darker brown posteriorly, lateral margin brown, ventral metasoma yellow in anterior half, then dark brown. *Head.* Dorsally with one pair of minor seta ss2 between posterior ocelli, inserted adjacent to occipital carina (Fig. 66), all setae S1–6 present, setal row sr2 present as 1–2 irregular rows of 8–10 setae reaching the bottom of the eye; occipital carina weak medially; width of eye: width of face:12:39, posterior margin eye of not nearly contiguous with posterior margin of head over most of length; ratio of MS:EH 12:24; lateral ocellus more than 1 diameter from eye (OD:OOD 8:12). Face below eyes rounded, not abruptly narrowing. Vertex under anterior ocellus reticulate. Toruli separated by about 2.5× their own diameters. Malar suture present below eye, fading ventrally. Area under eye lightly reticulate to alutaceous. Scape 4× as long as wide. Ratio of funicular segments 8:7:7:8:12, width 5 at F1 to 6 at club,

flagellar segments with small whorls of brown setae basally. *Mesosoma*. Pronotum anterior to transverse carina with scattered setae, finely rugosely reticulate, posterior to carina more openly reticulate and shiny. Mesoscutum (Fig. 64) reticulate, becoming more smooth, and shiny posteriorly. Mid-lobe with median carina well developed, fading over anterior 1/4, otherwise complete, not noticeably sunken posteriorly, with no small setae antero-laterally, posterior setae even with surface. Dorsal axillar/scutellar margin with broad, nearly straight deep furrow with flat bottom. Axillae shiny, openly reticulate. Scutellum shiny, lightly reticulate to alutaceous, smooth along posterior margin, slightly pointed at anterior margin with axillae. Metanotum bordered anteriorly by a narrow band of small alveoli, medially shiny and lightly reticulate (Fig. 65). Propodeum laterad of median carina shiny and smooth to the step-like plica, median carina with anterior cup-like flange rounded and invaginated. Area around spiracle granulate medially, openly reticulate laterally, spiracle slightly raised above surface and slanted so that opening is at a slight angle to the surface, with antero-lateral flange present, but somewhat reduced, with 6–8 setae laterad and below spiracle. Petiole in dorsal as wide as long (12:12), rugose dorsally with irregular longitudinal carina and smooth at posterior margin. *Metasoma*. Ovate, about 1.1–1.5× as long as wide. Legs. Ratio of hind tibial spur 1:spur 2:tarsus 1:T2:T3:T4. 32:22:20:13:8:12. Forewing. Hyaline, about 2.3× as long as wide. Costal cell with 2 irregular rows of setae ventrally. Venation yellow to white, ratio of postmarginal: stigmal (16:12).

*Male*.—Similar to female except: body length 1.6mm; antenna with scape white, slightly swollen, with narrow, elongate sensory area containing 2 irregular rows of sensillae extending about 3/4 length (Fig. 37); funicle ratios 7:7:7:7:11 width 5–

6, with scattered or whorled semi-erect brown setae on each flagellomere.

*Hosts*.—Unknown Geometridae.

*Distribution*.—Widely distributed in Costa Rica.

*Types*.—Holotype female: Costa Rica, Guanacaste Prov., Area de Conservación Guanacaste, Lambert N314800 E360500, 300m., VI. 24, 1993, 93-SRNP-2241, D.H. Janzen & W. Hallwachs. ex. Geometridae (deposited in INBIO). Paratypes: 7 females and 1 male with the same data as holotype; 1 female Costa Rica: Alajuela, 5km W. San Ramon, 1200m, IV. 1997, O. Castro & P. Hanson; 2 females Costa Rica: Puntarenas, San Vito, Estac. Biol. Las Alturas, 1500m, IV. 1992, Hanson & Godoy; 1 female Costa Rica: Cartago, 4km NE Cañon, Genesis II, 2300m, VIII. 1995, P. Hanson; 1 female Costa Rica: San José, Zurqui de Moravia, 1600m, X-XII. 1990, col. P. Hanson; 1 female Costa Rica: San José, Cerro de la Muerte, 19km S,3W Empalme, 2600m, IX. 1992, Hanson & Godoy; 1 female Costa Rica: Puntarenas, 23km N. Puerto Jiménez, LaPalma, 10m, XI-XII. 1992, col. P. Hanson (deposited in USNM with 1 female each to CNC and BMNH).

*Etymology*.—This species is named in honor of Julio Diaz Orias in special recognition of his many years of steadfast and energetic management of the fire prevention and control program of the Area de Conservación Guanacaste.

*Euplectrus rojasi* Schauff, new species  
(Figs. 68, 69)

*Diagnosis*.—Face below toruli dark yellow, brown under and between toruli; mandibles yellow; hind coxa mostly black; posterior margin of scutellum overlapping anterior metanotum (Figs. 68, 69); anterior extension of median propodeal carina flattened, not cup-like; petiole 1.5X as long as wide.

The flattened anterior cup-like flange of the median propodeal carina in this species is quite distinctive with anterior end of median carina usually expanded into a

rounded or triangular and invaginated "cup." In addition, this is the only specimen I have examined where the face under the toruli is brown medially between the toruli and becomes yellow laterally under the toruli. Of the species treated here, the anterior edge of the metanotum being covered by the posterior margin of the scutellum is also unusual. However, in *E. carlowae*, the lateral margins of the scutellum project over the lateral edges of the metanotum and the senior author has seen other specimens of apparently undescribed species which also have the scutellum overhanging the metanotum.

*Description*.—Female. Body length 2.2 mm. Color: body mostly black except the following: antenna with scape yellow to brown, pedicle becoming dark brown apically, flagellum light brown becoming darker brown apically; mandibles yellow; enlarged setae on vertex yellowish brown; legs yellow except hind coxa mostly black; dorsal metasoma mostly dark brown to black with small yellow spot antero-medially, ventral metasoma dark brown behind petiole, then yellow to about midpoint, then dark brown. *Head*. Dorsally with 5 minor seta ss2 between posterior ocelli, all seta S1–6 present, setal row sr2 present as 2 irregular rows of 15–20 setae reaching to bottom of eye; occipital carina weak medially; width of eye: width of face (35:13), posterior margin eye of not nearly contiguous with posterior margin of head over most of length. Ratio of MS:EH 16:30; lateral ocellus more than 1 diameter from eye (OD:OOD 5:8). Face below eyes rounded, not abruptly narrowing. Vertex under anterior ocellus reticulate to alutaceous. Toruli separated by about 2 $\times$  their own diameters. Malar suture absent. Area under eye lightly reticulate. Scape 6 $\times$  as long as wide. Ratio of funicular segments 10:11:11:11:18, width 5 at F1 to 6 at club, flagellar segments with small whorls of brown setae basally. *Mesosoma*. Pronotum anterior to transverse carina with scattered setae, finely rugosely reticulate, posterior to

carina reticulate and shiny. Mesoscutum (Fig. 68) reticulate, becoming more smooth, and shiny posteriorly. Midlobe with median carina fading in anterior half, not noticeably sunken posteriorly, with no small setae antero-laterally, posterior setae even with surface. Dorsal axillar/scutellar margin with narrowed, nearly straight deep furrow without flat bottom except medially. Axillae openly reticulate. Scutellum reticulate to alutaceous, smooth along posterior margin, posterior margin extended over anterior margin of metanotum, anterior margin pointed. Metanotum anteriorly covered by scutellum, medially shiny and smooth to lightly reticulate (Fig. 69). Propodeum laterad of median carina shiny and smooth to the step-like plica with occasional slight hints of reticulation, median carina with anterior cup-like flange flattened, not expanded and cup-like. Area around spiracle reticulate, spiracle slightly raised above surface and tilted toward median carina, with antero-lateral flange present, with 11 setae laterad and below spiracle. Petiole in dorsal view 1.5 $\times$  as long as wide (15:10), rugose dorsally. *Metasoma*. Ovate, about 1.5 $\times$  as long as wide. Legs. Ratio of hind tibial spur 1: spur 2:tarsus 1:T2:T3:T4. 40:27:30:16:10:16. Forewing. Hyaline, about 2.3 $\times$  as long as wide. Costal cell with 1–2 irregular rows of setae ventrally. Venation yellow light brown, ratio of postmarginal: stigmal (41:23).

*Male*.—Unknown.

*Hosts*.—Unknown.

*Distribution*.—Known only from the type locality.

*Types*.—Holotype female on point (antenna and wing slide-mounted) with data "Costa Rica, Cartago, 4 Km. NE., Cañon Genesis II, 2350M. VI. 1995. P. Hanson." (deposited in USNM).

*Notes*.—The presence of 5 setae ss2 is probably an anomaly. Other specimens rarely show 1 seta or 3 setae when the usual number is 0, 2, or 4. In this case, the

usual number for this species is probably 4 setae in this location.

*Etymology.*—This species is named in honor of Maria Zulay Guevara Rojas in special recognition of her dedicated attention to the Research Center and the dormitories in Sector Santa Rosa of the Area de Conservación Guanacaste.

***Euplectrus ronniei* Schauff, new species**  
(Figs. 31, 70, 71, 72, 73)

*Diagnosis.*—Face below and slightly laterad of toruli yellow; with one pair of setae ss2 between posterior ocelli (Fig. 70), seta S5 absent (see Fig. 23), scutellum shiny and lightly reticulate, petiole as wide as long. Male scape with small restricted brown spot on ventral surface, single short row of sensillae (Fig. 31).

This species is similar to *E. mariae* which has a similar overall appearance lacking the S5 setae and with a yellow face, but tends to be somewhat larger (generally over 2 mm) and the propodeum laterad of the median carina is nearly smooth whereas it is more irregularly rugose in *mariae*. *Euplectrus ronniei* is most easily diagnosed by the scape (Figs. 31, 73) of the males which have a small restricted brown patch on the antero-ventral surface with only a single small row of sensillae.

*Description.*—Female. Body length 1.6–2 mm. Color: body mostly black except the following: face below and between toruli yellow, extending laterally below toruli, but not reaching eye; antenna with scape whitish, flagellum yellow; mandibles yellow; legs yellow to white; dorsal metasoma with large central yellow area extending from just behind petiole posteriorly about 1/2 length of dorsum, becoming darker brown posteriorly, lateral margin brown, ventral metasoma yellow to white in anterior half, then becoming dark yellow. *Head.* Dorsally with one pair of minor seta ss2 between posterior ocelli (Fig. 70), seta S5 absent, setal row sr2 present as 1–2 irregular rows of 13–15 setae reaching the bottom of the eye; occipital carina

weak medially; width of eye: width of face:12:35, posterior margin eye of not nearly contiguous with posterior margin of head over most of length; ratio of MS: EH 14:25; lateral ocellus more than 1 diameter from eye (OD:OOD 6:7). Face below eyes rounded, not abruptly narrowing. Vertex under anterior ocellus reticulate. Toruli separated by about 2× their own diameters. Malar suture absent below eye. Area under eye lightly reticulate to alutaceous. Scape 5× as long as wide. Ratio of funicular segments 9:9:9:14, width 5 at F1 to 6 at club, flagellar segments with small whorls of brown setae basally. *Mesosoma.* Pronotum anterior to transverse carina with scattered setae, finely rugosely reticulate, posterior to carina more openly reticulate and shiny. Mesoscutum (Fig. 71) reticulate, becoming more smooth, and shiny posteriorly. Midlobe with median carina well developed, fading over anterior 1/3 to 1/4, otherwise complete, not noticeably sunken posteriorly, with no small setae antero-laterally, posterior setae even with surface. Dorsal axillar/scutellar margin with broad, nearly straight deep furrow with narrow, but flat bottom. Axillae shiny, openly reticulate. Scutellum shiny, lightly reticulate to alutaceous, smooth along posterior margin, pointed at axillar/scutellar margin. Metanotum bordered anteriorly by narrow band of small alveoli, medially shiny and lightly reticulate. Propodeum (Fig. 72) laterad of median carina shiny and lightly reticulate to the step-like plica, median carina with anterior cup-like flange rounded and invaginated. Area around spiracle dull, openly reticulate laterally, spiracle slightly raised above surface and slanted so that opening is at a slight angle to the surface, with antero-lateral flange present, but somewhat reduced, with 9–12 setae laterad and below spiracle. Petiole in dorsal view as wide as long (11:11), rugose dorsally with irregular longitudinal carina and almost smooth at posterior margin. *Metasoma.* Ovale, about 1.4–1.5× as long as wide.

Legs. Ratio of hind tibial spur 1:spur 2: tarsus 1:T2:T3:T4. 28:16:20:12:8:13. Forewing. Hyaline, about 2.3× as long as wide. Costal cell with 2 irregular rows of setae ventrally. Venation yellow to white, ratio of postmarginal: stigmal (22:16).

*Male*.—Similar to female except: body length 1.6 mm. Face white to yellow; antennal scape with small brown spot at apical ventral margin (Fig. 31) very slightly swollen, with narrow sensory area containing only 1 irregular row of sensillae extending about 1/4 length; funicle ratios 9:10:10:10:17 width 5 near base, 6 at club, with few scattered or whorled semierect brown setae on each flagellomere; metasoma white in dorsal 1/2 then dark brown, ventrally yellow becoming dark brown posteriorly.

*Hosts*.—*Oxidercia toxea* (Noctuidae), *Cautethia spuria* (Sphingidae).

*Distribution*.—Known only from the ACG.

*Types*.—Female holotype: Costa Rica Guanacaste Prov., Area de Conservación Guanacaste, Lambert N314800 E360500, 300m., VII.26.1992, 92-SRNP-3415, ex. *Cautethia spuria*, D.H. Janzen & W. Hallwachs (deposited in INBIO). Paratypes: 3 males same as holotype except with Lambert N313400 E358900, 280m., VIII. 28.1995, 95-SRNP-8256, ex. *Oxidercia toxea*; 1 female with Lambert N314800 E360500, 300m., VII. 26.1992, 92-SRNP-3415, ex. *Cautethia spuria* (deposited in USNM)

*Etymology*.—This species is named in honor of Ronald Hernández D'Avanzo in recognition of his dedicated management of the Human Resources office of the Area de Conservación Guanacaste.

### *Euplectrus solitarius* Ashmead

*Euplectrus solitarius* Ashmead 1904:517.

*Diagnosis*.—Face under toruli honey yellow, lighter area restricted to just under toruli; all major seta 1–6 present (see Fig. 23); one pair of small setae (ss2) between posterior ocelli (as in Fig. 70); first funicle

2× as long as wide; legs yellow; scutellum reticulate; petiole longer than wide; metasoma ovate with small yellow spot antero-medially becoming brown then dark brown laterally and posteriorly.

This species is very similar to *E. comstockii* but can be differentiated by the petiole which is slightly wider than long (longer than wide in *solitarius*). In addition, the first funicle in *solitarius* is 3× as long as wide while in *comstockii* F1 is 2× as long as wide.

I have seen very few specimens of this species and it is defined here mostly on the basis of the holotype which is missing most of its antennae. I have seen no males that I can definitively attribute to this species.

*Distribution*.—Mexico south to Brazil and Ecuador

*Hosts*.—Unknown.

*Types*.—Holotype female deposited in USNM, type no. 60573. Erroneously labelled as a male, this type is missing most of the antennae.

### *Euplectrus valverdei* Schauff, new species

(Figs. 17, 20, 21, 38, 74, 75, 76)

*Diagnosis*.—Face below toruli dark brown or black (as in Fig. 15); mandibles brown; hind femur and hind coxa darker than other legs (honey yellow to brown); minor seta ss2 absent between posterior ocelli (as in Fig. 82); anterior metanotum with narrow line of alveoli; malar suture visible at least near eye; propodeum laterad of median carina smooth. Male scape yellow and greatly swollen (Figs. 17, 38), surface covered with large sensillae (Figs. 20, 21, 75, 76).

In contrast to some of the other species with dark faces and hind coxae, the mandibles of this species are also brown (mandibles yellow in *xiomarae* and *orias*). The mandibles of *zamorai* are also brown, but that species has the antenna with the last two antennal flagellomeres dark contrasting sharply with the lighter preceding seg-

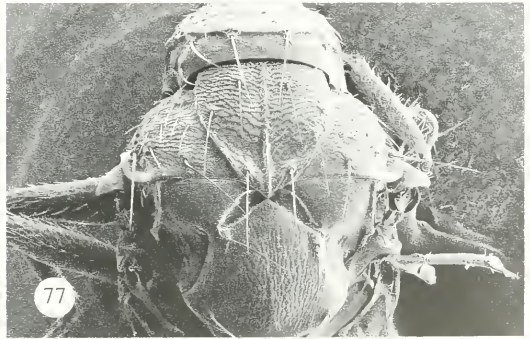
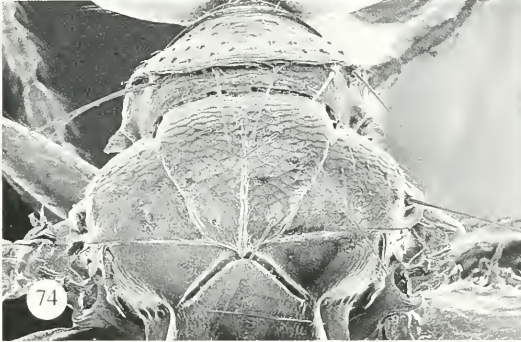
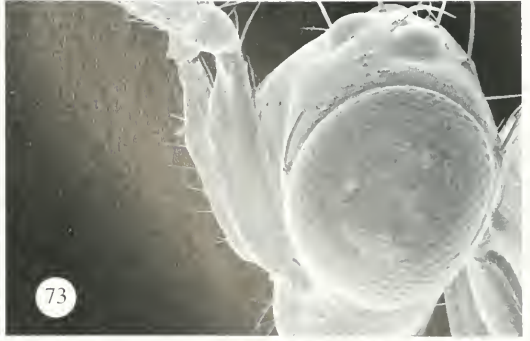

Figs. 72-79. *Euplectrus* scanning electron micrographs. 72-73, *E. ronnei*. 72, Propodeum. 73, Head, lateral view, male. 74-76, *E. valverdei*. 74, Dorsal mesosoma. 75, Male antennae and head. 76, Male scape. 77-79, *E. walteri*. 77, Dorsal mesosoma. 78, Propodeum. 79, Head.

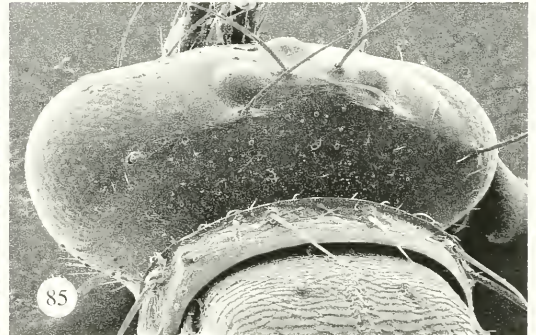
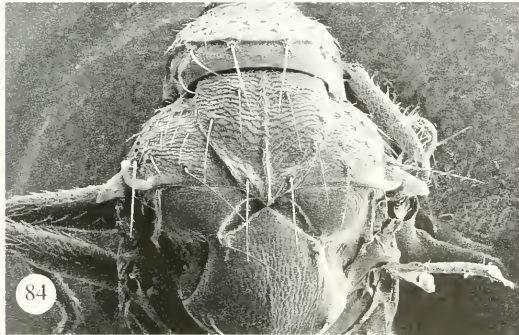
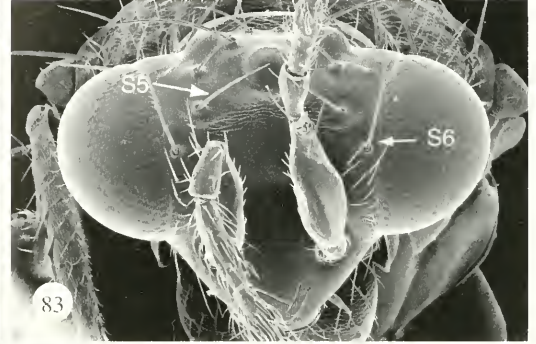
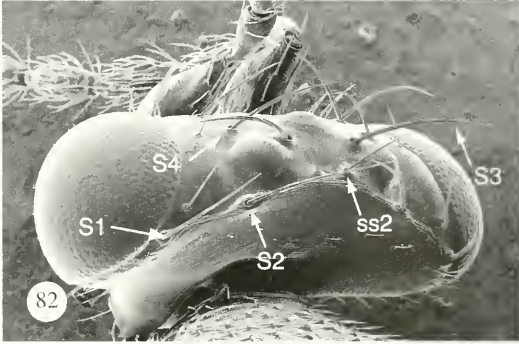

Figs. 80-87. *Euplectrus* scanning electron micrographs. 80-84, *E. walteri*. 80, Head lateral view. 81, Head, ventro-lateral view. 82, Head, postero-dorsal view. 83, Head, frontal view. 84, Dorsal mesosoma. 85-87, *E. xiomarae*. 85, Head, postero-dorsal view. 86, Dorsal mesosoma. 87, Thorax and propodeum.

ments. In addition, *E. valverdei* has the malar suture at least partially complete while in *zamorai* and *xiomarae* it is absent. Males of this species are very distinctive with greatly enlarged yellow scapes (Fig. 17) covered on all surfaces with distinctly granular sensillae (when viewed on slide) (Figs. 20, 21).

*Description.*—Female. Body length 1.7–2.1 mm. Color: body mostly black except the following: antenna with scape white to yellow, flagellum yellow to light brown; mandibles brown; enlarged setae on vertex silver; legs white to yellow except hind coxa and distal half of hind femur honey yellow to brown; dorsal metasoma with large central inverted T-shaped yellow area extending from just behind petiole posteriorly about 1/2 length of dorsum, becoming darker brown posteriorly, lateral margin brown except medially, ventral metasoma yellow or white in anterior half, then dark brown. *Head.* Dorsally with minor seta ss2 absent between posterior ocelli, all setae S1–6 present, setal row sr2 present as 2–3 irregular rows of 15–20 setae reaching to bottom of eye; occipital carina weak to absent; width of eye: width of face (40:13), posterior margin eye of not nearly contiguous with posterior margin of head over most of length. Ratio of MS:EH 18:28; lateral ocellus more than 1 diameter from eye (OD:OOD 6:8). Face below eyes abruptly narrowing. Vertex under anterior ocellus reticulate to alutaceous. Toruli separated by about 2.5× their own diameters. Malar suture present, but irregular, marked in some specimens by change in sculpture. Area under eye lightly reticulate to alutaceous. Scape 5× as long as wide. Ratio of funicular segments 11:11:11:11:18, width 5 at F1 to 6 at club, flagellar segments with small whorls of brown setae basally. *Mesosoma.* Pronotum anterior to transverse carina with scattered setae, finely rugosely reticulate, posterior to carina reticulate and shiny. Mesoscutum reticulate, becoming more smooth, and shiny posteriorly. Midlobe

(Fig. 74) with median carina nearly complete, fading at extreme anterior margin, not noticeably sunken posteriorly, with no small setae antero-laterally, posterior setae even with surface. Dorsal axillar/scutellar margin with broad, nearly straight deep furrow without flat bottom. Axillae nearly smooth, shiny, with faint open reticulation, pointed at anterior margin with axillae. Scutellum shiny, very lightly alutaceous, smooth along posterior margin. Metanotum anteriorly with narrow but distinct band of small alveoli, medially shiny and smooth. Propodeum laterad of median carina shiny and smooth to the step-like plica with occasional faint hints of reticulation, median carina with anterior cup-like flange rounded and invaginated. Area around spiracle reticulate, spiracle slightly raised above surface and parallel to the surface, with antero-lateral flange present, with 12–15 setae laterad and below spiracle. Posterior margin of propodeum with deep alveolus at posterior margin. Petiole in dorsal view slightly longer than wide (15:12), rugose dorsally. *Metasoma.* Ovate, about 1.3–1.6× as long as wide. Legs. Ratio of hind tibial spur 1:spur 2:tarsus 1:T2:T3:T4. 38:29:28:15:10:14. Forewing. Infusate light brown, about 2.3× as long as wide. Costal cell with 1 irregular row of setae ventrally. Venation yellow light brown, ratio of postmarginal:stigmatal (22:16).

*Male.*—Similar to female except: scape yellow and greatly swollen (Figs. 17, 38, 75, 76) and surface covered with large granulate appearing sensillae (Figs. 20, 21); face very narrow below toruli; legs generally white except hind leg yellow; 12:13:14:14:20, width 4–6 with no noticeable brown setae.

*Hosts.*—Unknown

*Distribution.*—Known only from the type locality.

*Types.*—Holotype female: Costa Rica, San José, Ciudad Colón, 800m, II. 1990, Col. Luis Fournier (deposited in INBIO). Paratypes: 4 females with same data as the

holotype; 2 males and 1 female with same data as holotype except III-IV. 1990 (deposited in USNM and BMNH).

*Etymology.*—This species is named in honor of Julio A. Quirós Valverde in recognition of his many years of service and diligent management of police and protection services for the Area de Conservación Guanacaste.

*Euplectrus walteri* Schauff, new species  
(Figs. 13, 29, 77–84, 89)

*Diagnosis.*—First funicular segment nearly equal in length to club (similar to Fig. 25), face below toruli yellow, with 1 pair of setae ss2 (as in Fig. 70) between posterior ocelli, toruli separated by about 4× their own diameter; posterior margin of eye nearly contiguous with posterior margin of head over most of length (as in Fig. 80, 82); scutellum heavily sculptured (Fig. 84); postmarginal vein almost 2× stigmal (see Fig. 18). Male F1 subequal to club, club swollen with broad, ovate sensory area containing several irregular rows of sensillae extending about 3/4 length (Fig. 30, 81).

The widely separated toruli and long first funicular segment (almost as long as the club) make this species easily recognizable among those with a yellow face. In addition, the scutellum is much more heavily sculptured than most of the other species. The antenna of *E. hansonii* is somewhat similar with F1 almost the same length as the club, but in that species all the funicles are elongated and about 3× as long as wide. In addition, the eyes of *walteri* are large and the hind margin is contiguous with the back of the head over most of its length.

*Description.*—Female. Body length 2.9–3.2 mm. Color: body mostly black except the following: face below and between toruli yellow (Fig. 13); antenna with scape white to light yellow, flagellum yellow or light brown; mandibles yellow to white; legs light yellow to white; dorsal metasoma with large central yellow to white area

extending from just behind petiole posteriorly about 1/2 length of dorsum, becoming darker brown posteriorly, lateral brown margin broken medially, ventral metasoma yellow to white. *Head.* Dorsally with one pair of minor seta ss2 between posterior ocelli (Fig. 82), inserted adjacent to occipital carina, setae S1–6 present, setal row sr2 present as 1–3 irregular rows of 15–20 setae reaching the bottom of the eye; occipital carina complete; width of eye: width of face:18:48, posterior margin eye of nearly contiguous with posterior margin of head of most of length; ratio of MS: EH 17:31; lateral ocellus more than 1 diameter from eye (OD:OOD 8:10). Face below eyes abruptly narrowing. Vertex below anterior ocellus alutaceous. Toruli separated by about 4× their own diameters (Fig. 13). Malar suture absent. Area under eye lightly reticulate. Scape 6× as long as wide. Ratio of funicular segments 19:17:17:15:20, width 8 at F1 to 9 at club, flagellar segments without small whorls of brown setae basally. *Mesosoma.* Pronotum anterior to transverse carina with scattered setae, finely rugosely reticulate, posterior to carina more openly reticulate and shiny. Mesoscutum reticulate (Fig. 84), nearly rugose anteriorly, becoming more smooth, and shiny posteriorly. Midlobe with median carina well developed, fading over anterior 1/4, otherwise complete, slightly sunken posteriorly, small setae antero-laterally usually absent, rarely with 2, posterior setae even with surface or slightly raised. Dorsal axillar/scutellar margin with broad, curved deep furrow with flat bottom. Axillae shiny, openly reticulate. Scutellum heavily reticulate to alutaceous, smooth along posterior margin, anteriorly distinctly pointed at axillar/scutellar margin. Metanotum bordered anteriorly by narrow band of small alveoli, medially shiny and lightly reticulate. Propodeum (Fig. 78) laterad of median carina shiny and openly reticulate to the step-like plica, median carina with anterior cup-like flange rounded and invaginated. Area

around spiracle granulate medially, openly reticulate laterally, spiracle slightly raised above surface and slanted so that opening is almost perpendicular to surface, with antero-lateral flange large and obvious, with 8–12 setae laterad and below spiracle. Posterior margin of propodeum without deep alveolus at posterior margin. Petiole in dorsal view as wide as long or very slightly longer than wide (11:12), rugose dorsally with irregular longitudinal carina and smooth at posterior margin. *Metasoma*. Ovate, about 1.1–1.5× as long as wide. Legs. Ratio of hind tibial spur 1:spur 2:tarsus 1:T2:T3:T4. 55:37:35:20:11:21. Forewing. Hyaline, about 2.3× as long as wide. Costal cell with 2 irregular rows of setae ventrally. Venation yellow to white, ratio of postmarginal: stigmal (42:22).

*Male*.—Similar to female except: body length 1.7–1.9 mm. Face yellow to white, legs white to light yellow, metasoma with central white spot only extending about 1/2 length, dark brown posteriorly, laterally dark brown to light brown, ventrally posterior half dark brown; antenna with scape white, swollen medially (Figs. 80, 81), with broad, ovate sensory area containing several irregular rows of sensillae extending about 3/4 length (Figs. 13, 29); funicle ratios 17:16:15:13:18, width 5–6, with scattered or whorled semierect brown setae on each flagellomere.

*Hosts*.—*Manduca barnesi*, *M. dilucida*, *M. florestan*, *M. lanuginosa*, *M. rustica*, *Perigonia ilus* (all Sphingidae).

*Notes*.—Some setal variation on the mesoscutum has been observed in specimens of this species. While this character is generally very stable and no small setae are present, there are occasionally setae present antero-laterally near the anterior enlarged setae on the midlobe.

*Types*.—Holotype female: Costa Rica, Guanacaste Prov., Area de Conservación Guanacaste, Lambert N312450 E359500, 270m., VIII. 13, 1995, 95-SRNP-7544, D.H. Janzen & W. Hallwachs. ex. *Manduca flo-*

*restan* (deposited in INBIO). Paratypes: 2 females all with the same data as holotype; other specimens with some of the same information are except: 3 males and 1 female with Lambert N313100 E359900, 250m., VII. 30. 1992, 92-SRNP-3174; 3 males with Lambert N313100 E359900, 250m., VII. 30. 1992, 92-SRNP-4114; 2 males and 2 females with Lambert N313800 E359800, 300m., VI. 30. 1984, 84-SRNP-653, ex. *Manduca dilucida*; 1 male with Lambert N313800 E359800, 300m., VI. 23. 1993, 93-SRNP-2239 ; 1 female with Lambert N314800 E360500, 300m., VII.1.1984, 84-SRNP-805, ex. *Manduca dilucida*; 1 male and 2 females with Lambert N313100 E359900, 250m., VII.27.1992, 92-SRNP-3018, ex. *Manduca rustica*; 1 female with Lambert N315500 E360200, 300m., VIII.2.1992, 92-SRNP-3811; 2 females with Lambert N313100 E359900, 500m., VIII.1.1992, 92-SRNP-3708; 1 male with Lambert N317800 E362600, 300m., VI.28.1984, 84-SRNP-623, ex. *Manduca dilucida*; 1 female with Lambert N314800 E360500, 300m., VIII.16.1981, 81-SRNP-1141, ex. *Perigonia ilus*; 2 males and one female with Lambert N312450 E359300, 270m., VI.27.1996, 96-SRNP-6830; 1 female with Lambert N315500 E360200, 300m., VII.2.1992, 92-SRNP-2262, ex. *Manduca lanuginosa*; 2 females and 1 male with Lambert N313400 E358900, 280m., X.3.1996, 96-SRNP-10435; 1 female with Lambert N313800 E359800, 300m., XII.11.1990, 90-SRNP-2507, ex. *Manduca rustica*; 1 females and 1 male with Lambert N313400 E358900, 280m., VII.28.1991, 91-SRNP-1636; 2 females with Lambert N313400 E358900, 280m., VI.18.1994, 94-SRNP-4497, ex. *Manduca barnesi* (paratypes deposited in USNM, BMNH, and CNC).

*Etymology*.—This species is named in honor of Walter Bonilla Vásquez in special recognition of his dedicated management of the Accounting Office for the Area de Conservación Guanacaste.

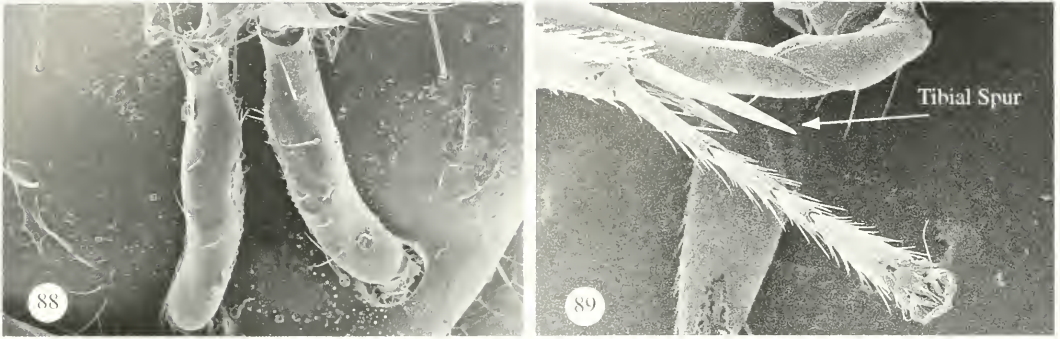

Figs. 88–89. *Euplectrus* scanning electron micrographs. 88, *E. xiomarae*, Male scapes. 89, *E. walteri*, Hind tibia and tarsi.

*Euplectrus xiomarae* Schauff, new species

(Figs. 8, 9, 11, 19, 36, 85–87)

*Diagnosis.*—Face below toruli dark brown (as in Fig. 13); mandibles yellow; hind coxa dark brown (Fig. 11) and hind femur with distal half brown; ss2 setae absent between posterior ocelli (Fig. 85); malar suture absent below eye. Male antenna with scape white, slightly swollen (Fig. 36, 88), with narrow, elongate sensory area containing 2 irregular rows of sensillae extending about 1/3 length.

This is one of the small group of species with a dark face and dark hind coxae. It is most similar to *E. janiciei* which, like *xiomarae*, lacks small setae between the posterior ocelli. *Euplectrus xiomarae* can be separated by the presence of yellow mandibles (mandibles brown in *janiciei*) and lack of a malar suture (malar suture present in *janiciei*).

*Description.*—Female. Body length 1.8–2.2 mm. Color: body mostly black except the following: face below and between toruli brown; antenna with scape yellow, flagellum yellow or light brown; mandibles yellow; legs yellow-brown except hind coxa mostly dark brown, hind femur with distal half brown; dorsal metasoma with large central yellow area extending from just behind petiole posteriorly about 1/2 length of dorsum, becoming darker brown posteriorly, lateral margin brown,

ventral metasoma yellow in anterior half, then dark brown. *Head.* Dorsally with minor seta ss2 absent between posterior ocelli (rarely with 1) (Fig. 85), all setae S1–6 present, setal row sr2 present as 1–2 irregular rows of 8–10 setae reaching the bottom of the eye; occipital carina weak; width of eye: width of face:38:12, posterior margin eye of not nearly contiguous with posterior margin of head over most of length. Ratio of MS:EH 18:28; lateral ocellus more than 1 diameter from eye (OD:OOD 6:10). Face below eyes rounded, not abruptly narrowing. Vertex under anterior ocellus reticulate. Toruli separated by about 2.1× their own diameters. Malar suture absent below eye. Area under eye lightly reticulate. Scape 4× as long as wide. Ratio of funicular segments 12:11:11:11:17, width 6 at F1 to 7 at club, flagellar segments with small whorls of brown setae basally. *Mesosoma.* Pronotum anterior to transverse carina with scattered setae, finely rugosely reticulate, posterior to carina more openly reticulate and shiny. Mesoscutum (Fig. 86) reticulate, becoming more smooth, and shiny posteriorly. Mid-lobe with median carina fading over anterior 1/4, otherwise complete, not noticeably sunken posteriorly, with no small setae antero-laterally, posterior setae even with surface. Dorsal axillar/scutellar margin with broad, nearly straight deep furrow with flat bottom. Axillae shiny, open-

ly reticulate. Scutellum shiny, lightly reticulate to alutaceous, smooth along posterior margin, pointed at anterior margin with axillae. Metanotum bordered anteriorly by a narrow band of small alveoli, medially shiny and lightly reticulate (Fig. 87). Propodeum laterad of median carina lightly reticulate, shiny to the step-like plica, median carina with anterior cup-like flange nearly triangular and invaginated, with transverse carina. Area around spiracle openly reticulate laterally, spiracle slightly raised above surface and slanted so that opening is at a slight angle to the surface, with antero-lateral flange large, obvious, with 9–12 setae laterad and below spiracle. Posterior margin of propodeum without deep alveolus at posterior margin. Petiole in dorsal about as wide as long (12:13), rugose dorsally. *Metasoma*. Ovate, about 1.2–1.5× as long as wide. Legs. Ratio of hind tibial spur 1:spur 2: tarsus 1:T2:T3:T4. 35:26:21:15:10:16. Forewing. Hyaline, about 2.3× as long as wide. Costal cell with 2 irregular rows of setae ventrally. Venation yellow to white, ratio of postmarginal: stigmal (25:18).

*Male*.—Similar to female except: body length 1.9 mm; antenna with scape white, slightly swollen (Fig. 19, 36, 88), with narrow, elongate sensory area containing 2 irregular rows of sensillae extending about 1/3 length; funicle ratios 11:11:13:13:17 width 5–6, with scattered or whorled semierect brown setae on each flagellomere.

*Hosts*.—*Hemiceras clarki*, *H. corema*, *H. nigrescens*, *Rosema attenuata* (all Notodontidae).

*Notes*.—One female specimen has been observed with a single ss2 seta instead of the usual two. This further confirms that there may be some variation in this character although overall it is quite stable.

*Distribution*.—Known only from the ACG.

*Types*.—Holotype female: Costa Rica, Guanacaste Prov., Area de Conservación Guanacaste, Lambert N318500 E359850,

240m., VIII. 20, 1993, 93-SRNP-4388, D.H. Janzen & W. Hallwachs. ex. *Hemiceras clarki* (deposited in INBIO). Paratypes: 3 females with the same data as holotype; other specimens with some of the same information are except: 3 males and 2 females with Lambert N318500 E359850, 240m., VIII. 22. 1992, 92-SRNP-4609; 1 male and 2 females with Lambert N318500 E359850, 240m., VIII. 16. 1993, 93-SRNP-4384; 3 females with Lambert N313500 E359850, 240m., VIII. 22. 1992, 92-SRNP-4614; 1 female with Lambert N318500 E359850, 240m., VIII.23.1992, 92-SRNP-4642; 1 female with Lambert N318500 E359850, 240m., VIII.22.1992, 92-SRNP-4602; 3 females with Lambert N318500 E359850, 240m., VIII. 23. 1992, 92-SRNP-4652, ex. *Rosema attenuata* (deposited in the USNM and BMNH, INBIO, and CNC).

*Etymology*.—This species is named in honor of Xiomara Driggs Valerín in special recognition of her dedicated management of the Human Resources office of the Area de Conservación Guanacaste.

#### *Euplectrus zamorai* Schauff, new species (Fig. 22)

*Diagnosis*.—Face below toruli dark brown or black (as in Fig. 15); mandibles brown; seta S4 and seta ss2 absent (as in Fig. 85); funicle yellow except last two segments dark brown (Fig. 22); malar suture absent below eye; setal line sr2 reduced; anterior metanotum without alveoli; propodeum laterad of median carina smooth.

The contrasting distal antennal segments of this species readily set it apart from similar species such as *orias* and *valverdei* which also have a dark face and dark hind coxae but unicolorous, or only gradually darkening, flagellar segments. *Euplectrus furnius* also has the apical flagellar segments contrasting with F1, but that species has the ocellus more than 2× its diameter removed from the margin of the eye (just over 1× in *zamorai*) and the face is about 4× as wide as the width of the eye (just over 2× in *zamorai*).

*Description.*—Female. Body length 1.7–2 mm. Color: body mostly black except the following: antenna with scape yellow, flagellum yellow, last 2 flagellomeres brown or light brown; mandibles brown; legs yellow except hind coxa brown; dorsal metasoma with large central yellow area extending from just behind petiole posteriorly about 2/3 length of dorsum, becoming darker brown posteriorly, lateral margin brown, ventral metasoma yellow in anterior half, then dark brown. *Head.* Dorsally with minor seta ss2 absent between posterior ocelli, seta S4 absent, setal row sr2 present but reduced to 1 short row of 3–4 setae with an additional seta or two near bottom of eye; occipital carina weak to absent; width of eye: width of face: 33:14, posterior margin eye of not nearly contiguous with posterior margin of head over most of length. Ratio of MS:EH 15:28; lateral ocellus more than 1 diameter from eye (OD:OOD 6:8). Face below eyes abruptly narrowing. Vertex under anterior ocellus reticulate. Toruli separated by about 2× their own diameters. Malar suture absent below eye. Area under eye lightly reticulate to alutaceous. Scape 5× as long as wide. Ratio of funicular segments 12:13:13:12:16, width 5 at F1 to 6 at club, flagellar segments with small whorls of brown setae basally. *Mesosoma.* Pronotum anterior to transverse carina with scattered setae, finely rugosely reticulate, posterior to carina more nearly smooth with slight open reticulation and shiny. Mesoscutum reticulate, becoming more smooth, and shiny posteriorly. Mid-lobe with median carina nearly complete, fading at extreme anterior margin, not noticeably sunken posteriorly, with no small setae antero-laterally, posterior setae even with surface. Dorsal axillar/scutellar margin with narrow, nearly straight deep furrow without flat bottom. Axillae nearly smooth, shiny, with faint open reticulation. Scutellum shiny, very lightly alutaceous, smooth along posterior margin. Metanotum anteriorly nearly contiguous

with scutellum, without obvious narrow band of small alveoli, medially shiny and smooth. Propodeum laterad of median carina shiny and smooth to the step-like plicca, median carina with anterior cup-like flange rounded and invaginated. Area around spiracle reticulate, spiracle slightly raised above surface and parallel to the surface, with antero-lateral flange present, with 6–8 setae laterad and below spiracle. Posterior margin of propodeum without deep alveolus at posterior margin. Petiole in dorsal as wide as long (12:12), rugose dorsally. *Metasoma.* Ovate, about 1.1–1.5× as long as wide. Legs. Ratio of hind tibial spur 1:spur 2:tarsus 1:T2:T3:T4. 31:22:22:11:8:14. Forewing. Infusate light brown, about 2.3× as long as wide. Costal cell with 1 irregular row of setae ventrally. Venation yellow light brown, ratio of post-marginal: stigmal (22:13).

*Male.*—Unknown.

*Hosts.*—Unknown.

*Distribution.*—Known only from the type localities.

*Types.*—Holotype female: Costa Rica, Heredia, Chilamate, 75m., XII.1989, III.1989, Hanson & Godoy (deposited in USNM). Paratypes: 2 females with same data as holotype except V. 1989; 1 female IX-X.1989; 1 female Guanac, Est. Pitilla, 9 km S Santa Cecilia, 700m., V.1988, P. Hanson (deposited in USNM).

*Etymology.*—This species is named in honor of Luis Federico Garita Zamora in recognition of his many years of steadfast and enlightened management of field operations and construction management for the Area de Conservación Guanacaste.

#### ACKNOWLEDGMENTS

We thank Tami Carlow for technical assistance. Paul Hanson, Univ. of Costa Rica, kindly allowed us access to his collections of specimens. Drs. G. Zolnerowich, S. Lingafelter, D. Smith and M. Gates reviewed the manuscript and provided many helpful comments. This study was supported by NSF grants BSR 90–24770, DEB 93–06296, DEB 97–05072, BSR 80–11558, BSR 83–07887, and BSR 87–06155. This study would not have been possible without the support of

a number of Lepidoptera systematists and the rearing support of the paracologists cited at <http://janzen.sas.upenn.edu>.

## LITERATURE CITED

- Ashmead, W. H. 1904. Classification of the chalcid flies of the superfamily Chalcidoidea, with descriptions of new species in the Carnegie Museum, collected in South America by Herbert H. Smith. *Memoirs of the Carnegie Museum* 1: i-ix, 225-551.
- Bouček, Z. 1977. Descriptions of two new species of Neotropical Eulophidae (Hymenoptera) of economic interest, with taxonomic notes on related species and genera. *Bulletin of Entomological Research* 67: 1-15.
- Bouček, Z. 1988. *Australian Chalcidoidea (Hymenoptera). A Biosystematic Revision of Genera of Fourteen Families, with a Reclassification of Species*. CAB International. 832 pp.
- Burks, B. D. 1979. Eulophidae, pp. 967-1022. In K. V. Krombein, P. D. Hurd, Jr., D. R. Smith, B. D. Burks, eds. *Catalog of the Hymenoptera in American North of Mexico. Vol. 1. Symphyta and Apocrita (Parasitica)*. Smithsonian Institution Press, Washington, D.C. 1198 pp.
- Coudron, T. A. and S. L. Brandt. 1996. Characteristics of a developmental arrestant in the venom of the ectoparasitoid wasp *Euplectrus comstockii*. *Toxicon* 34: 1431-1441.
- Coudron, T. A. and Puttler, B. 1988. Response of natural and factitious hosts to the ectoparasite *Euplectrus plathypenae* (Hymenoptera: Eulophidae). *Annals of the Entomological Society of America* 81: 931-937.
- Dangerfield, P. C., J. B. Whitfield, M. J. Sharkey, D. H. Janzen and I. Mercado. 1996. *Hansonia*, a new genus of cardiocliline Braconidae (Hymenoptera) from Costa Rica, with notes on its biology. *Proceedings of the Entomological Society of Washington* 98: 592-596.
- DeSantis, L. 1967. *Catálogo de los Himenópteros Argentinos de la Parasítica, Incluyendo Bethyloidea*. Publicación especial. Comisión de Investigaciones Científicas de la Provincia de Buenos Aires. LaPlata, Argentina. 337 pp.
- DeSantis, L. 1979. *Catálogo de los Himenópteros Calcidoideos de América al Sur de los Estados Unidos*. Publicación especial. Comisión de Investigaciones Científicas de la Provincia de Buenos Aires. LaPlata, Argentina.
- DeSantis, L. 1980. *Catálogo de los Himenópteros Brasileños de la serie Parasítica Incluyendo Bethyloidea*. Editora de Universidade Federal do Paraná Curitiba. 395 pp.
- DeSantis, L., and P. Fidalgo. 1994. *Catálogo de Himenópteros Calcidoideos*. Serie de la Academia Nacional de Agronomía y Veterinaria. No. 13. 154 pp.
- Ferrière, C. 1941. New species of Euplectrini (Hym. Chalcidoidea) from Europe, Africa and Asia. *Bulletin of Entomological Research* 32(1): 17-48.
- Gauld, I. D., K. J. Gaston and D. H. Janzen. 1992. Plant allelochemicals, tritrophic interactions and the anomalous diversity of tropical parasitoids: the "nasty" host hypothesis. *Oikos* 65: 353-357.
- Gauld, I. D. and D. H. Janzen. 1994. The classification, evolution and biology of the Costa Rican species of *Cryptophion* (Hymenoptera: Ichneumonidae). *Zoological Journal of the Linnean Society* 110: 297-324.
- Gonzalez, A. 1985. Revision of the genus *Euplectrus* (Hym.—Eulophidae) of the New World. Ph.D. Thesis. University of California, Riverside.
- Howard, L. O. 1880. A new silk-spinning chalcid. *Canadian Entomologist* 12: 158-159.
- Howard, L. O. 1885. Descriptions of North American Chalcididae from the collections of the U.S. Department of Agriculture and of Dr. C. V. Riley, with biological notes. Together with a list of the described North American species of the family. USDA. *Bulletin of the Bureau of Entomology* 5: 5-47.
- Howard, L. O. 1897. On the Chalcididae of the Island of Grenada, B.W.I. *Journal of the Linnean Society, Zoology* 26: 129-178.
- Janzen, D. H. 1993. Caterpillar seasonality in a Costa Rican dry forest. In: *Caterpillars. Ecological and Evolutionary Constraints on Foraging*, N. E. Stamp and T. M. Casey, eds., Chapman and Hall, New York, pp. 448-477.
- Janzen, D. H. 2000. Costa Rica's Area de Conservación Guanacaste: a long march to survival through non-damaging biodevelopment. *Biodiversity* 1: 7-20.
- Janzen, D. H. and I. D. Gauld 1997. Patterns of use of large moth caterpillars (Lepidoptera: Saturniidae and Sphingidae) by ichneumonid parasitoids (Hymenoptera) in Costa Rican dry forest. In: *Forests and Insects*, eds. A. D. Watt, N. E. Stork and M. D. Hunter, Chapman & Hall, London, pp. 251-271.
- Janzen, D. H. and W. Hallwachs. 2000. Philosophy, navigation and use of a dynamic database ("ACG Caterpillars SRNP") for an inventory of the macrocaterpillar fauna, and its food plants and parasitoids, of the Area de Conservación Guanacaste (ACG), northwestern Costa Rica (<http://janzen.sas.upenn.edu>).
- Janzen, D. H., M. J. Sharkey, and J. M. Burns. 1998. Parasitization biology of a new species of Braconidae (Hymenoptera) feeding on larvae of Costa Rican dry forest skippers (Lepidoptera: Hesperidae: Pyrginae). *Tropical Lepidoptera* 9 (Suppl.): 33-41.

- Noyes, J. S. 1998. Catalogue of the Chalcidoidea of the World. *Biodiversity catalogue database and image library CD Rom series*. ETI Biodiversity Center, Amsterdam, Netherlands.
- Puttler, B., G. Gordh, and S. H. Long. 1980. Bionomics of *Euplectrus puttleri* Gordh, new species, an introduced parasite of the velvetbean caterpillar, *Anticarsia gemmatalis* from South America. *Annals of the Entomological Society of America* 73:28–35.
- Sharkey, M. J. and D. H. Janzen. 1995. Review of the world species of *Sigalaphus* (Hymenoptera: Braconidae: Sigalaphinae) and biology of *Sigalaphus romeroi*, new species. *Journal of Hymenoptera Research* 4: 99–109.
- Walker, F. 1843. Descriptions of Chalcidites discovered in St. Vincents Isle by the Rev. Lansdown Guilding. *Annals and Magazine of Natural History* 12: 46–49.
- Wijsekara, G. A. W. and M. E. Schauff. 1994. Revision of the tribe Euplectrini of Sri Lanka (Hymenoptera: Eulophidae) *Oriental Insects* 28: 1–48.
- Wijsekara, G. A. W. and M. E. Schauff. 1997. Two new genera and species of Euplectrini (Hymenoptera: Eulophidae) from the New World. *Proceedings of the Entomological Society of Washington* 99: 101–109.
- Zitani, N. M., S. R. Shaw, and D. H. Janzen. 1997. Description and biology of a new species of *Meteorius* Haliday (Hymenoptera: Braconidae, Meteorinae) from Costa Rica, parasitizing larvae of *Papilio* and *Parides* (Lepidoptera: Papilionidae). *Journal of Hymenoptera Research* 6: 178–185.

## The Southern African Wasp Genus *Handlirschia* Kohl, 1897 (Hymenoptera: Apoidea, Sphecidae, Bembicinae)

MICHAEL OHL

Museum für Naturkunde der Humboldt-Universität Berlin, Institut für Systematische Zoologie,  
Invalidenstr. 40, D-10099 Berlin, Germany, E-mail: michael.ohl@rz.hu-berlin.de

---

*Abstract.*—The poorly known digger wasp genus *Handlirschia* is revised for the first time, and two species are recognized, *aethiops* (Handlirsch, 1889) and *scoliaeformis* (Arnold, 1929); the latter is newly transferred from *Stizus*. *Handlirschia tricolor* Gess, 1973, is synonymized with *scoliaeformis* and a lectotype is designated for *Stizus scoliaeformis*. The revision includes diagnoses, descriptions, illustrations of significant characters for each species, and a distribution map. The phylogenetic position of *Handlirschia* within the Bembicinae is discussed.

---

*Handlirschia* Kohl, 1897 is a poorly known genus of digger wasp from southern Africa that was described for the single species, *Stizus aethiops* Handlirsch, 1889. The latter was based on a single male from eastern South Africa that remains the only specimen known. Gess (1973), without having seen the holotype of *aethiops*, described a second species, *Handlirschia tricolor*, based on five specimens, also from eastern South Africa.

As the first step toward a comprehensive revision of *Stizus*, I have compiled the original descriptions of species assigned to that genus. Based on the published description and figures, *Stizus scoliaeformis* Arnold, 1929, seemed to be unusual in lacking diagnostic characters of Stizini and Bembicini, such as an elongate submarginal cell I (Bohart and Menke 1976, Ohl 1999). Examination of the type series showed that *Stizus scoliaeformis* actually belongs in the genus *Handlirschia* within Gorytini (sensu Bohart and Menke 1976), and that *Stizus scoliaeformis* and *Handlirschia tricolor* are synonyms. Since then, roughly 50 more specimens of *Handlirschia*, all *scoliaeformis* (= *tricolor*), came to my attention. These findings prompted me to revise the genus in order to evaluate

its species composition, provide diagnostic characters of the included species, and evaluate its phylogenetic relationships.

Diagnosis sections are not provided here since only two species are involved, and their defining characters are presented in the key.

### TECHNICAL TERMS

Most morphological terms follow Bohart and Menke (1976). However, a few are explained here for convenience. I follow Melo (1999) in adopting the terminology of Smith (1970) for male genitalia.

*Gonapophysis*: penis valve of Bohart and Menke (1976).

*Gonocoxite*: gonostyle of Bohart and Menke (1976).

*Metapostnotum*: usually referred to as 'propodeal triangle', 'triangular area' or 'propodeal enclosure' in Apoidea, but in fact the metathoracic postnotum that is fused to the true propodeum (Brothers 1976). In *Handlirschia* the metapostnotum is more or less triangular and extends slightly onto the posterior surface of the propodeum.

*Placoids and tyloids*: I follow Bohart and Menke (1976:23–24) in distinguishing two kinds of specialized regions on male antennae. **Placoids** are "platelike, flat, or curved areas . . . that are . . . depressed below level of surrounding integument", whereas a **tyloid** is

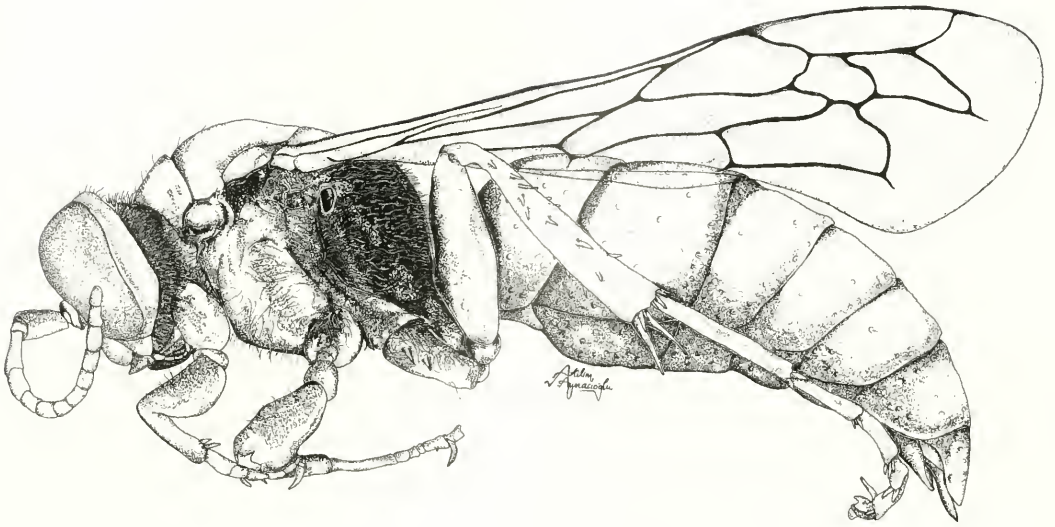

Fig. 1. *Handlirschia scoliaformis*, male, habitus. Namibia, Okahandja.

defined as a "linear welt or cariniform swelling."

*Torulus* (plural: toruli): antennal socket of Bohart and Menke 1976, i.e., the socket on the frons of the face upon which the scape of the antenna is articulated (Fig. 2a).

All illustrations (except for Fig. 1, which is a traditional ink drawing) were prepared on a personal computer using Adobe® programs: a pencil drawing made with a camera lucida was digitized with a scanner as a bitmap-based illustration and then imported into the Adobe® Streamline 4.0 program. This software converts bitmap-based illustrations into vector-based illustrations, which were then modified in the Adobe® Illustrator 7.0 program to prepare the final illustrations.

Locality names are arranged in alphabetical order within each country, district, or province, respectively. Coordinates were taken from various sources, especially the catalogue of southern African place names by Leistner and Morris (1976) and the GEOnet names server of the NIMA Geographic Names Database (<http://gnpswww.nima.mil/geonames/GNS/index.cfm>). All coordinates follow the convention used by the 'Times Atlas of the

World' (i.e., 21.55S 16.08E instead of 21°55'S 16°08'E).

#### ORIGIN OF MATERIAL

Institutional or personal collections in which the material is deposited are abbreviated in the text as follows (names of contact person are in parentheses):

- AMGS Albany Museum, Grahamstown, South Africa (Fred W. Gess).
- BMNH British Museum (Natural History), London (Christine Taylor).
- CAS California Academy of Sciences, San Francisco, USA (Wojciech J. Pulawski).
- CSE Personal collection of Christian Schmid-Egger, Berlin, Germany.
- MS Personal collection of Maximilian Schwarz, Ansfelden, Austria.
- NHMW Naturhistorisches Museum, Wien, Austria (Stefan Schödl).
- OHL Personal collection of Michael Ohl, Berlin, Germany.
- SAM South African Museum, Cape Town, South Africa (Margie A. Cochrane).
- USNM Smithsonian Institution, National Museum of Natural History,

Washington, D.C., USA (Maureen J. Mello).

### Genus *Handlirschia* Kohl, 1897

*Handlirschia* Kohl, 1897:425. Type species: *Sphēcicus aethiops* Handlirsch, 1889, by monotypy.

**Diagnosis.**—*Handlirschia* is a member of Gorytini (Bohart and Menke 1976), an assemblage of 39 genera (Bohart 2000) that apparently lacks any apomorphy (see phylogenetic discussion below). The most important diagnostic features, which taxonomically place *Handlirschia* in Gorytini are the combination of two midtibial spurs (Fig. 2e), a keel-like basomedian ridge on sternum I, and submarginal cell I not unusually elongate (Fig. 2b). Within Gorytini, *Handlirschia* belongs to the branch of genera with an oblique scutal carina (Fig. 2c). Among these, it can be recognized by the lack of both a sternaulus and an omaulus, and by the presence of spiracular lobes in the male. Additionally, the inner eye margins are almost parallel (Fig. 2a), whereas the margins converge ventrally in some other gorytin genera.

**Description.**—A redescription of *Handlirschia* is provided because Bohart and Menke (1976) based their generic diagnosis and description on the single known specimen of *aethiops*. They treated as distinctive for *Handlirschia* some characters of male *aethiops* that do not occur in *scoliaeformis* (e.g., the prominent male sternal fimbriae and somewhat distorted apical flagellomeres). Included are those characters that vary within other Gorytini but are constant within *Handlirschia*. Reference is made to Stizini and Bembicini, which also have spiracular lobes in the male.

Head shape simple (Fig. 2a): eye inner margins almost parallel; frons with angular, transverse swelling below ocelli, shallowly depressed above antennae; toruli well above frontoclypeal margin; subantennal sutures well developed, reaching frontoclypeal suture between anterior tentorial pits; clypeus slightly, evenly convex,

maximum width 2.5–2.8x median length; mandibles slightly curved subapically, with an inner preapical tooth; male antennae with tyloids and/or placoids. Pronotal collar (Fig. 2d) sloping gently, separated from scutum by transverse groove, topped by a sharp edge (less so in *scoliaeformis*); scutum with well-defined oblique scutal carina (Fig. 2c); omaulus, sternaulus, episternal sulcus and acetabular carina absent. Hindleg arolium smaller than other arolia (Fig. 2f,g); midtibia with two prominent spurs (Fig. 2e). Wings (Fig. 2b) infumate; pterostigma ill-defined, parallel-sided, posterior margin straight; both recurrent veins received by submarginal cell II; jugal lobe larger than tegula; hindwing media diverging before cu-a. Propodeum without spiracular groove; propodeal hindcorners projecting, hindface concave. Metapostnotum an equilateral triangle; median propodeal pit forming longitudinal groove that extends from posterior third of metapostnotum slightly onto propodeal hindface and that is delimited by distinctive carinae; the latter project onto the propodeal hindface almost down to the propodeal orifice. Tergum VII with large spiracular lobe (Fig. 5c). Sternum I with median carina distally (in addition to much larger basomedian carina) and many oblique to longitudinal rugulae; sternum II with basal hump (Fig. 1) and prominent, deep, transverse groove anterior to it; sternum VII largely reduced to a membranous sclerite between spiracular lobes (Fig. 5c).

Unfortunately, the genitalia and metasomal segment VIII of the holotype of *aethiops* were lost after Handlirsch (1889:469) studied them. He described them as follows: "The genitalia are almost the same as in the preceding species [which is a *Sphēcicus* in the sense of Bohart and Menke 1976], except for the sagitta lacking the outer point" (my translation). Segments VII-VIII and the genitalia were dissected and originally glued onto card bottom, which is pinned under the specimen. Only

segment VII (and most of the right antenna) is still present. Only two generic characters can be extracted from Handlirsch's description and *scoliaeformis*. Obviously sternum VIII is indeed narrowed to a sharp spine (Figs. 1, 5d, e). Apparently, the "outer point of the sagitta" [= volsella] is the cuspis, which also lacks in *scoliaeformis* (Fig. 5a, b). Absence of a cuspis is thus a generic character of *Handlirschia*. The alleged similarity to *Sphecius* is not informative, because there are remarkable differences in the male genitalia between *Handlirschia scoliaeformis* and the species of *Sphecius* that I have studied (*antennatus*, *grandis*, *hogardii*, *pectoralis*, *speciosus*, and *spectabilis*).

*Phylogenetic Position.*—A few pre-cladistic hypotheses on the relationships of *Handlirschia* have been published. Handlirsch (1889:467) placed *aethiops* in *Sphecius*, pointing out that "within that genus, *aethiops* represented a group of its own" (my translation). Kohl (1897) established a monotypic genus, *Handlirschia* for *aethiops*, which he supposed to be "intermediate between *Sphecius* and *Stizus*". He gave a list of characters to differentiate *Handlirschia* from the latter two genera and concluded that "apparently, *Handlirschia* is closer to *Stizus* than to *Sphecius*" (Kohl's *Stizus* included *Bembecinus*, to which he probably referred). Arnold (1929) placed *scoliaeformis* in *Stizus* and commented: "Quite unlike any other species of the genus and perhaps deserving to rank as the type of a subgenus" (Arnold 1929:318). Gess (1973) compared his new species, *tricolor*, only with *Sphecius*, thus implying placement in the Gorytini. Bohart and Menke (1976) emphasized the similarity of *Handlirschia* to *Sphecius* and *Kohlia* and considered *Handlirschia* as the most basal branch of those Gorytine that have an oblique scutal carina (Bohart and Menke 1976:509, Fig. 155). Furthermore, they "put it on a separate line of evolutionary development in the general direction of the Bembicini and Stizini . . . In fact *Hau-*

*dlirschia* would probably be put in Stizini except for the rather typical gorytin wing venation" (Bohart and Menke 1976:509).

A comprehensive cladistic evaluation of the phylogenetic position of *Handlirschia* is beyond the scope of the present paper. *Handlirschia* is a member of Gorytini (sensu Bohart and Menke 1976, Bohart 2000) within the clade Bembicinae (sensu Melo 1999). As Bohart and Menke (1976) indicated, the Gorytini are a group of genera united only by symplesiomorphic features. Therefore, the tribe is probably a paraphyletic assemblage (Fig. 3a). Alexander's (1992) phylogenetic analysis of the Apoidea did not evaluate the phylogenetic status of the Gorytini, because he used tribes as terminal taxa. Melo (1999) analyzed the relationships within Apoidea on the level of genera representing most of Bohart and Menke's tribes. Although he used only two representatives of the remarkably heterogeneous Gorytini (*Hoplisoides* and *Ochleroptera*), his results support the assumption of its paraphyly.

Nemkov and Lelej (1996) presented a cladistic analysis of Gorytini (Fig. 3b). They did not include any outgroup (e.g., Stizini, Bembicini) in their study, however, so that they could not test the phylogenetic status of Gorytini. They studied no specimens of *Handlirschia* and relied on characters listed by Bohart and Menke (1976), some of which are lacking in *scoliaeformis*. They established a new subtribe, *Handlirschiina*. This subtribe is not recognized here, because it is a redundant name for an already named clade, *Handlirschia*. Recognition of *Handlirschiina* would not be an improvement neither for taxonomic nor for phylogenetic purposes. Nemkov and Lelej placed *Handlirschia* as the basal branch of the assemblage of gorytine genera with an oblique scutal carina (Fig. 3b). This is not surprising because an oblique scutal carina is indeed a characteristic of most Gorytini (except for five genera). However, Nemkov and Lelej did not consider the potentially significant fact

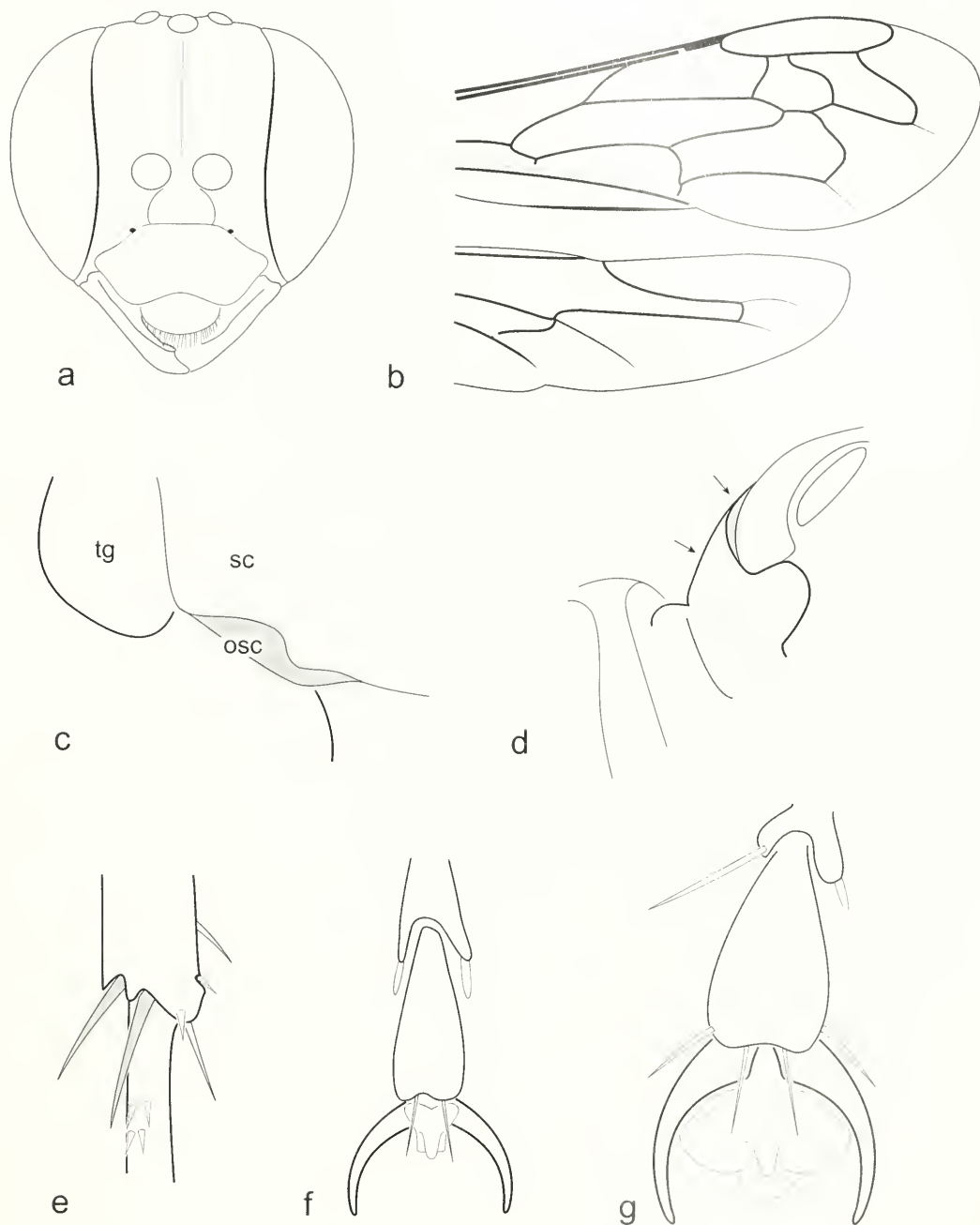
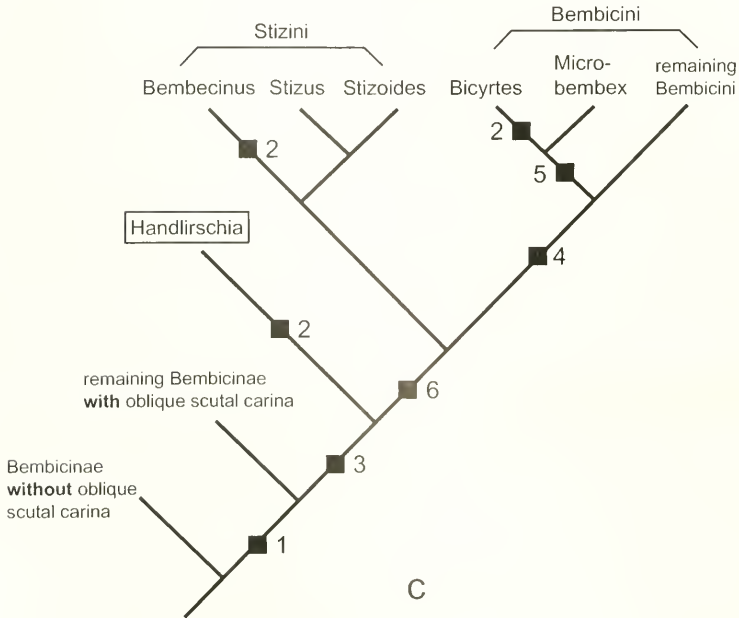
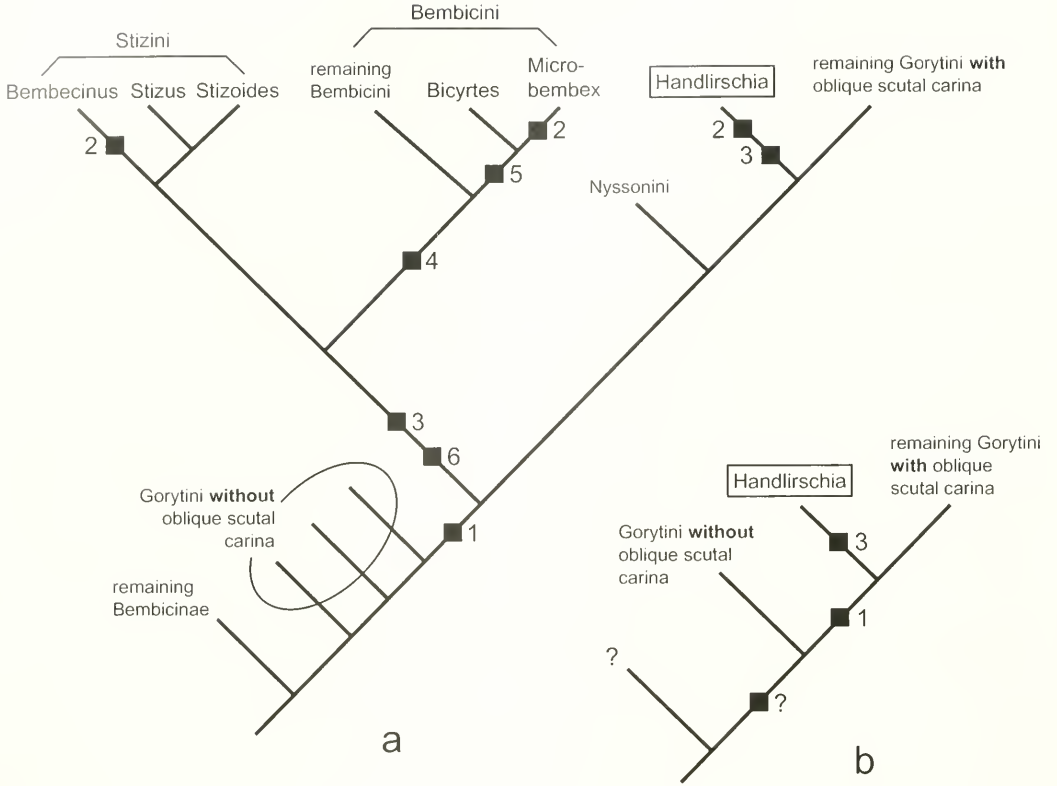

Fig. 2. *Handlirschia*. Some generic characters (drawn from Namibian specimens of *scoliaciformis*). a, Fore and hindwing. b, Head frontally. c, Oblique scutal carina (osc), left posterior edge of scutum (sc) (tg = tegula). d, Anterior part of thorax (arrows indicate gently sloping pronotum and sharp-edged posterior groove, respectively). e, Apex of left midtibia with two midtibial spurs. f, Hindtarsomeres IV-V. g, Foretarsomeres IV-V (female).



that an oblique scutal carina is also present in Nyssonini, Stizini, and Bembicini within Bembicinae.

The only unique apomorphy of *Handlirschia* that Nemkov & Lelej (1996) identified is the presence of spiracular lobes of tergum VII (Figs. 4a, 5c). Besides *Handlirschia*, this character occurs only in Stizini and most Bembicini (lobes missing in *Bicyrtes* and *Microbembex*), which together form a monophyletic group based on the presence of an unusually elongate submarginal cell I. Since Nemkov and Lelej (1996) did not include Stizini and Bembicini in their analysis, not surprisingly they considered the presence of a spiracular lobe as an apomorphy of *Handlirschia*. A preliminary alternative interpretation is depicted in Fig. 3c and explained below.

The other three characters mentioned by Nemkov & Lelej (1996) as homoplastic apomorphies for *Handlirschia* are of less or no phylogenetic significance: (a) labrum prominent (weakly contrasting with the alternative character state "labrum inconspicuous", and very likely modified secondarily); (b) omaulus absent (omaulus missing in many other gorytine genera); (c) terga III, IV, and sometimes V with dense, apical fimbriae (present only in *Handlirschia aethiops*).

In summary, Kohl (1897) and more explicitly Bohart and Menke (1976) were the first to imply a close relationship of *Handlirschia* with Stizini and Bembicini, although they still placed the genus in Gor-

ytni. As discussed above there is indeed a good reason to suppose that *Handlirschia* and Stizini + Bembicini together form a monophyletic group, at least based on the striking presence of spiracular lobes. Fig. 3c illustrates this preliminary hypothesis based on the assumption of a unique development of spiracular lobes, thus placing *Handlirschia* as the sister group of Stizini + Bembicini. This tree agrees with a unique evolution of the elongate submarginal cell I in Stizini + Bembicini and the unique loss of the spiracular lobes in *Bicyrtes* and *Microbembex*, but still implies a parallel evolution of the concave propodeal hindface in *Handlirschia*, *Bembecinus*, and *Bicyrtes*, respectively. Based on the six characters considered here, the hypothesis in Fig. 3c is more parsimonious than Bohart and Menke's hypothesis (Fig. 3a): there is no length difference for characters 1-2 and 4-6 on the two trees, but spiracular lobes (character 3) were evolved only once in Fig. 3c rather than twice in Fig. 3a. However, this conflicting character polarization can only be more definitively resolved in the frame of a cladistic analysis of the entire Bembicinae, taking into account much more characters and taxa.

*Life History*.—Unknown. The presence of a female foretarsal rake suggests ground nesting. Flower records are known only for *scoliaefornis* and are derived exclusively from the fieldwork of S.K. Gess and F.W. Gess, Grahamstown, South Africa. These data are given in the Life History section of *scoliaefornis*.

#### KEY TO SPECIES OF *HANDLIRSCHIA*

(The female of *aethiops* is unknown.)

1. Metapostnotum smooth, shiny, contrasting with coarsely, irregularly punctatorugose propodeal dorsum. Metapleuron and anterior part of propodeal side smooth, shiny. Black,

←

Fig. 3. *Handlirschia*. Three hypotheses on the phylogenetic relationships within the Bembicinae. a, Combined and redrawn after Bohart and Menke (1976: Figs 155, 181). b, Redrawn after Nemkov and Lelej (1996: Fig. 2). c, Preliminary hypothesis of the present paper. For discussion see Phylogenetic Position section. Character numbers: 1 = oblique scutal carina present, 2 = concave hindface of propodeum, 3 = presence of spiracular lobes, 4 = ocelli deformed, 5 = spiracular lobes reduced, 6 = elongate submarginal cell I.

- appendages and face partly yellow-orange (males only?). Metasoma covered by distinctive erect setae that are two midocellar diameters long, pale on terga I-II, black on III-IV. Males: sterna III-V with short, erect, apical fimbriae (Fig. 4f); flagellomeres IV-XI shallowly excavated ventrally, with broad placoids; femora and tibiae conspicuously modified (see Description for details). . . . . *aethiops* (Handlirsch)
- Metapostnotum and propodeal dorsum coarsely punctatorugose to finely rugose (except for small impunctate area at apex of metapostnotum). Metapleuron and anterior part of propodeal side microsculptured, dull. Thoracic dorsum and at least basal terga largely yellow-orange. Metasoma with short, appressed, golden setae less than one diameter long. Males: Sterna without fimbriae; flagellomeres V-IX at most slightly convex ventrally, with narrow, linear tyloids; legs unmodified. . . . . *scoliaeformis* (Arnold)

***Handlirschia aethiops* (Handlirsch, 1889)**

(Fig. 4)

*Sphecius Aethiops* Handlirsch, 1889:467, male, incorrect original capitalization. Holotype: male, South Africa: "Caffraria" [eastern South Africa, see note below]; no specific locality (NHMW), examined.—As *Handlirschia aethiops*: Kohl, 1897:425 (new combination); Arnold, 1929:259 (Handlirsch's description translated into English); Bohart and Menke, 1976:509 (listed); Dollfuss, 1989:9 (holotype in NHMW).

*Description*.—(Based on holotype, a male.) Length 13.8 mm. Black with the following yellow-orange: antennae, labrum, clypeus, frons below upper rim of toruli (somewhat extending above toruli at inner eye margin), and a narrow streak behind each eye. Flagellomeres II-XI somewhat distorted: II with oblique, inner ventral depression; III ventrolaterally with slightly convex, elongate, black spot, otherwise unmodified; IV with similar but much smaller spot and comma-shaped tyloid on ventral surface; V-VIII with depressed, shiny, ventral placoids; IX with a tiny, basoventral tyloid. Frons punctatorugose; vertex microsculptured, with scattered punctures, markedly punctured between ocelli and at posterior margin of vertex. Scutum shiny, with punctures about one diameter apart; punctures on scutellum and metanotum less than one diameter apart to subcontiguous. Mesopleuron coarsely and densely punctate, largely covered with long, dense, pale setae, al-

most obscuring sculpture. Metapleuron and metapostnotum impunctate, shiny. Propodeal side impunctate and shiny before spiracle, coarsely and sparsely punctate behind spiracle, many punctures more than one diameter apart. Propodeal hindface coarsely punctatorugose laterally, with irregular, longitudinal carinae medially. Forefemoral venter markedly convex, with many erect, pale setae; foretibia with conspicuous, toothlike projection anterobasally (Fig. 4e). Midfemur clublike (Fig. 4b), widest in apical half, depressed in basal half. Midtibia (Fig. 4b, c) deeply emarginate at spur insertion and pointed apically, with two prominent, apical spurs, inner surface with a prominent toothlike projection. Hindfemur parallel-sided, almost cylindrical (Fig. 4d). Setae pale on terga I-II, brown on terga III to VII. Tergal punctation coarse, sparsest on tergum I (many punctures 2–3 diameters apart), becoming denser from tergum II to VII. Setae pale on sterna I-III, brownish on IV-VII. Sternum II with rounded, basal hump. Sterna coarsely punctate to punctatorugose throughout. Sterna III-V with apical fimbriae (Fig. 4f), shortest on sternum III (The setae of the sternal fimbriae are fused into compact triangles of remarkably similar size (Fig. 4f). This is probably a preservation artifact, and it is most likely the fimbriae originally formed compact, homogeneous rows). Sternum VII (Fig. 4a) small, sclerotized median part triangular, membranous laterally. Spirac-

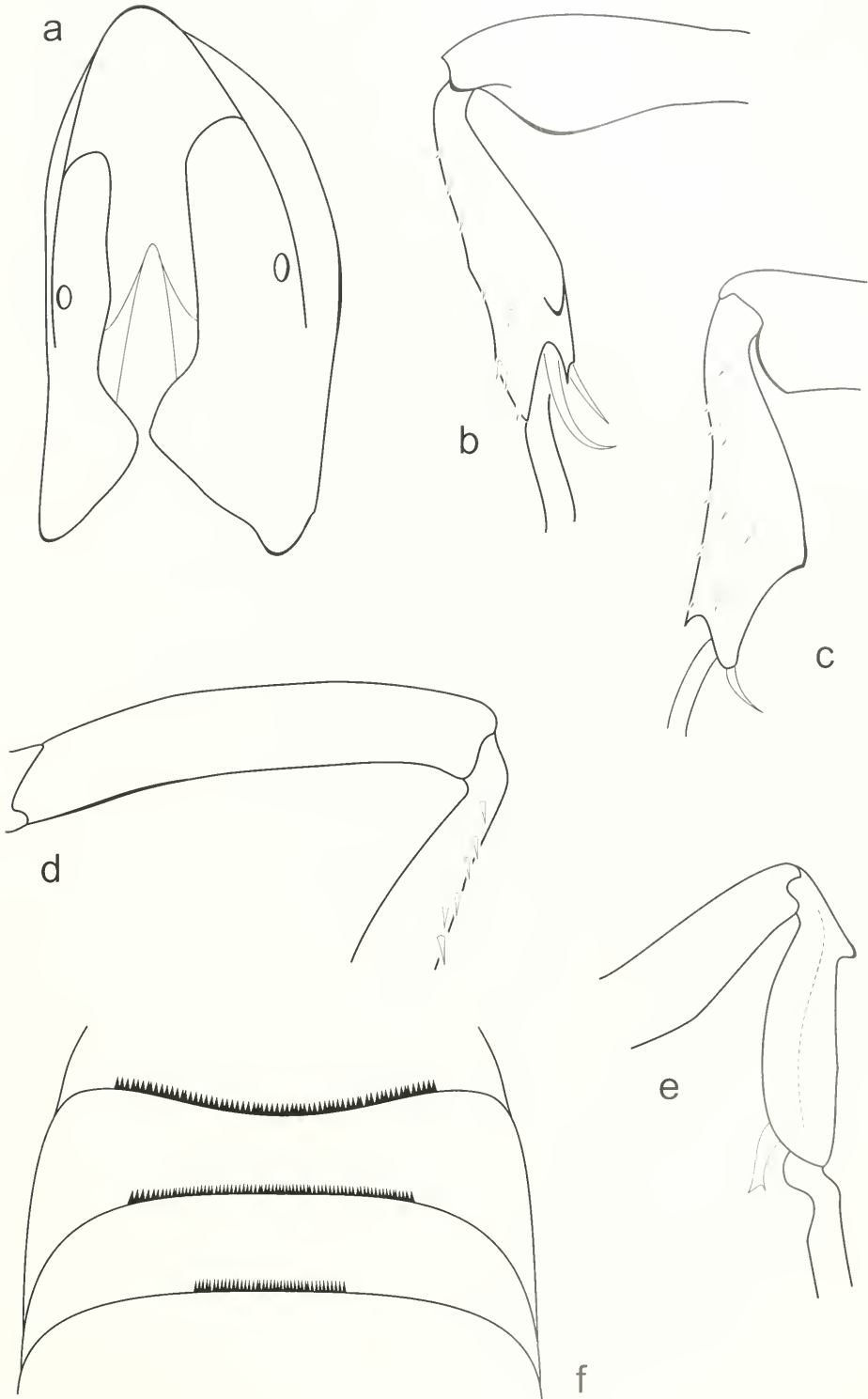

Fig. 4. *Handlirschia aethiops*. a, Segment VII in oblique ventral view. b-c. Right foreleg, b, Anterior view. c, Oblique lateral view. d, Right hindleg, posterior view. e, Right midleg, posterior view. f, Sterna III-V, posterior margins with apical fimbriae.

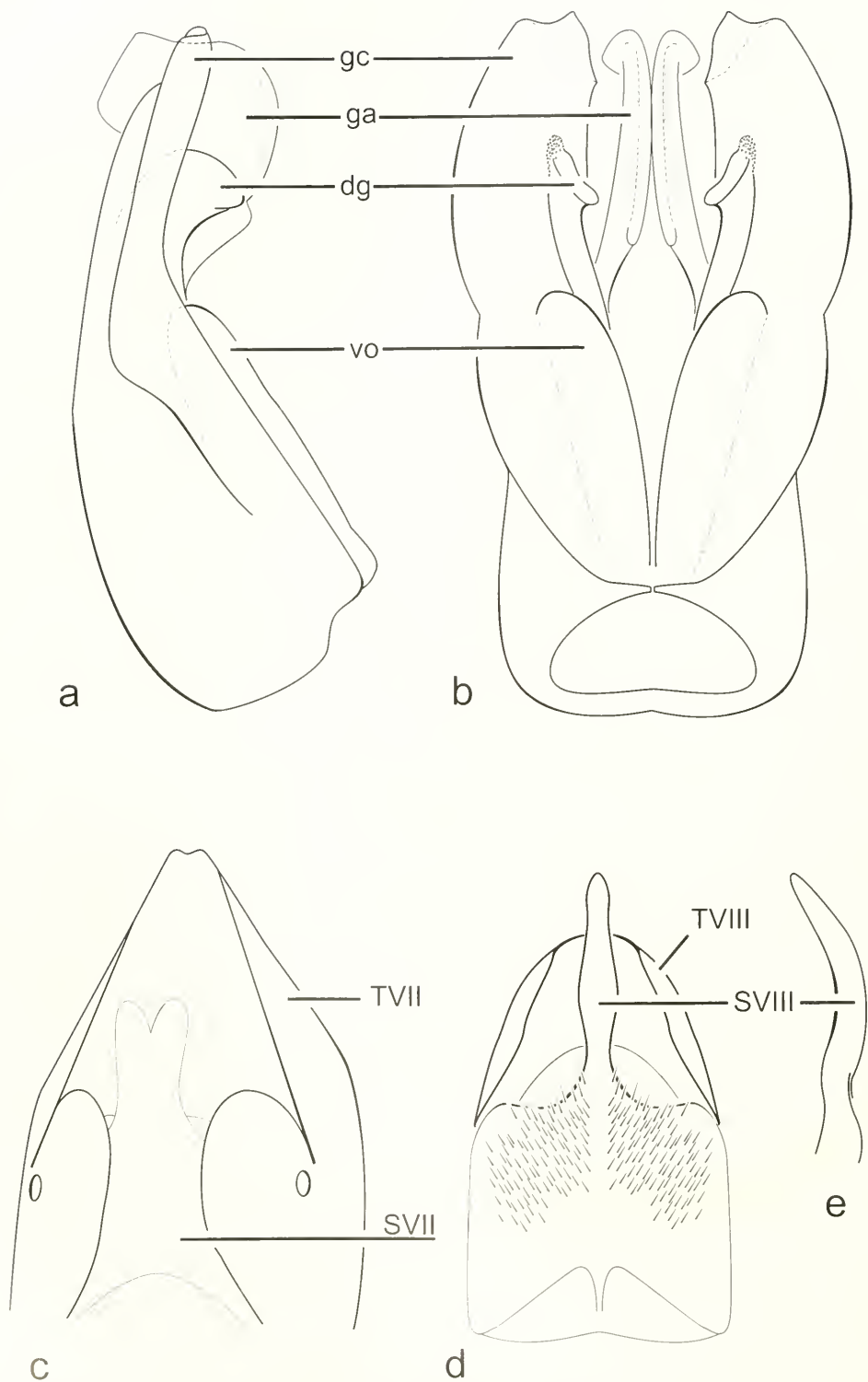

Fig. 5. *Handlirschia scoliaeformis*, male genitalia and metasomal segments VII–VIII. a, Genitalia, lateral view. b, Genitalia, ventral view (slightly compressed to spread gonapophysis). c, Segment VII, oblique ventral view.

ular lobes of tergum VII long (Fig. 4a), extending over more than half of total tergal length, approaching midline basally. Metasomal segment VIII and genitalia missing.

*Type Locality and Collector.*—Handlirsch (1889:469) gave the following information on the holotype of *aethiops*: “Süd-Afrika, Caffraria, Mus. Vindob. Coll. Winthem” (Mus. Vindob. = NHMW). Webster’s Geographical Dictionary defines Caffraria (or Kaffraria) as “a region of Eastern Cape Province . . . from Great Kei River on South to KwaZulu-Natal Province on North between the Drakensberg and the coast; largely equivalent to the main portion of former Transkei . . .”. In the early 19<sup>th</sup> century, however, Caffraria was sometimes used in a broader sense, probably covering most of eastern South Africa (F. Gess, pers. comm., Oct 2000). The holotype is undated, but “Coll. Winthem” probably refers to the collection of Wilhelm von Winthem (1799–1847), whose Hymenoptera and Diptera material was transferred to the NHMW in 1852 (Horn et al. 1990). Von Winthem apparently never traveled outside of Europe, but he communicated with “close to 200 scientific correspondents” (Steetz 1848), who identified, exchanged, and donated material, and he also purchased collections. Thus, the holotype of *aethiops* was obviously collected before 1847, but most likely not by von Winthem.

*Variation and Life History.*—Unknown.

*Geographic Distribution.*—Eastern South Africa is known.

*Material Examined.*—SOUTH AFRICA: “Caffraria” (= eastern South Africa): no specific locality (holotype male, NHMW).

*Handlirschia scoliaeformis* (Arnold, 1929), new combination  
(Figs. 1–2, 5–7)

*Stizus scoliaeformis* Arnold, 1929:317, female, male. Lectotype: male, Namibia: Kaokoveld, Warmbad (SAM), present designation (here designated in order to ensure the name’s proper and consistent application), examined.—Bohart and Menke, 1976:527 (listed).

*Handlirschia tricolor* Gess, 1973:103, female, male. Holotype: male, South Africa: Transvaal: Gravelotte, Beacon Ranch (AMGS), not examined. New synonym.—Bohart and Menke, 1976:509 (listed).

*Description.*—*Handlirschia scoliaeformis* was described in length by Gess (1973, as *tricolor*), whose paper should be consulted for more details. For coloration see Variation section below. Frons microsculptured, impunctate, dull. Pronotal collar microsculptured, with a few scattered macropunctures. Mesopleuron coarsely, densely punctate medially. Metapleuron and propodeal side before propodeal spiracle impunctate, dull; posterior half of propodeal side with coarse, scattered punctures that are denser posteriorly. Metapostnotum and hindcorners and dorsum of propodeum coarsely punctatorugose. Hindface of propodeum with two longitudinal carinae. Midtibial spurs prominent, straight (Fig. 2e). Anterior hump of sternum II impunctate, microsculptured along midline. Sterna densely punctate, except sternum II obliquely punctatorugose laterally.

*Female.*—Length 8.8–15.8 mm. Foreleg with foretarsal rake. Scutum, scutellum, and metanotum indistinctly punctatorugose. Foreleg arolium and tarsomere V markedly enlarged (Fig. 2g). Tergum I

←

d, Segment VIII in ventral view. e, Apical spine of sternum VIII, lateral view. Abbreviations: dg = digitus; ga = gonapophysis; gc = gonocoxite; vo = volsella; SVII/SVIII = sternum VII and VIII; TVII/TVIII = tergum VII and VIII.

densely punctate throughout, punctures denser and shallower on following terga.

*Male*.—Length 10.0–16.9 mm. Flagellomeres III–VII with linear tyloids, VIII with a circular tyloid, IX in most specimens without modifications, in some specimens with tiny, polished, basal spot. Scutum indistinctly punctatorugose, single punctures discernible toward posterior margin. Hindfemoral dorsum convex. Punctuation of tergum I coarse, many punctures about one diameter apart, less than that on tergum II, shallower and denser on terga III to VI, tergum VII coarsely punctate. Spiracular lobes of tergum VII short, rounded, not extending beyond basal third of tergal length (Fig. 5c). Sternum VII membranous, bilobed apically (Fig. 5c). Sternum VIII with a slightly curved, sharp spine (Fig. 5d, e). Gonocoxite with folded, membranous tip (Fig. 5a, b). Gonapophysis compressed laterally (Fig. 5b), rounded in lateral view (Fig. 5a). Lateral margin of volsella embedded in and hardly discernible from basoventral part of gonocoxites (Fig. 5b); cuspis missing; digitus markedly sclerotized, narrow, with minute teeth dorsally (Fig. 5b).

*Variation*.—*Handlirschia scoliaeformis* shows a remarkable geographic color variation: almost all specimens from Namibia are extensively marked with yellow or yellow-orange, with a strongly contrasting black propodeum (Fig. 6a). Moreover, all terga are almost completely yellow-orange, with only the tergal margins narrowly black and with the band of tergum I broken into two large spots. In some specimens one or more of the basal terga have additional black markings, but the apical terga always have complete yellow bands (Fig. 6a). In contrast, specimens from eastern South Africa, including the types of *tricolor*, have the propodeum largely yellow-orange (Fig. 6b) or at least with some yellow-orange markings (Fig. 6c). Additionally, the basal terga have more yellow than the terminal ones, which are usually all black (at least terga

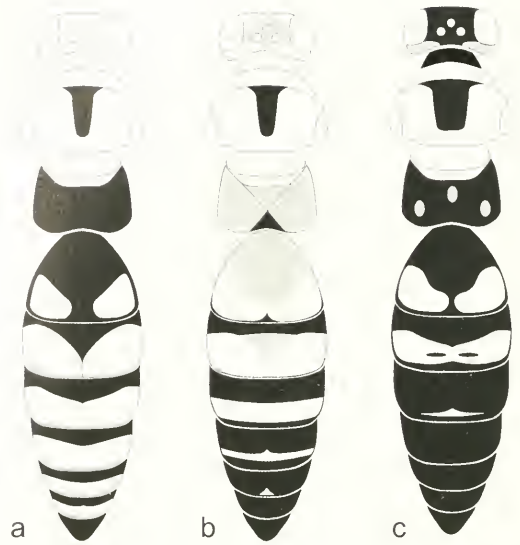

Fig. 6. *Handlirschia scoliaeformis*. Geographic color variation (based on males, but females exhibit the same tendency). Colors used: white = yellow-orange, black = black, grey = dark reddish-brown. a, Namibia, 30 km W Okahandja. b, South Africa, Gravelotte (paratype male of *H. tricolor*). c, South Africa, Ellisras.

V–VI in females and V–VII in males) (Fig. 6b, c). The same holds for coloration of the head, which has more black in eastern (Fig. 6c) than in western specimens (Fig. 6a). One female from Rundu (Namibia) is intermediate in having a predominantly yellow-orange propodeum, a partly black face, and largely black, terminal terga. In addition to color, specimens from western Namibia average larger (females 11.2–15.8 mm, males 12.8–16.9 mm long) than specimens from eastern South Africa (females 8.8–13.0 mm, males 10.0–14.1 mm long).

Although I did not study the holotype of *tricolor* and some other material from Namibia, housed in the AMGS, Fred Gess (pers. comm.) confirmed that these specimens correspond exactly to the above observations.

*Life History*.—All information on the life history of *scoliaeformis* is derived from the fieldwork of Sarah K. Gess and Fred W. Gess (Grahamstown, South Africa), including identification of prey and flowers.

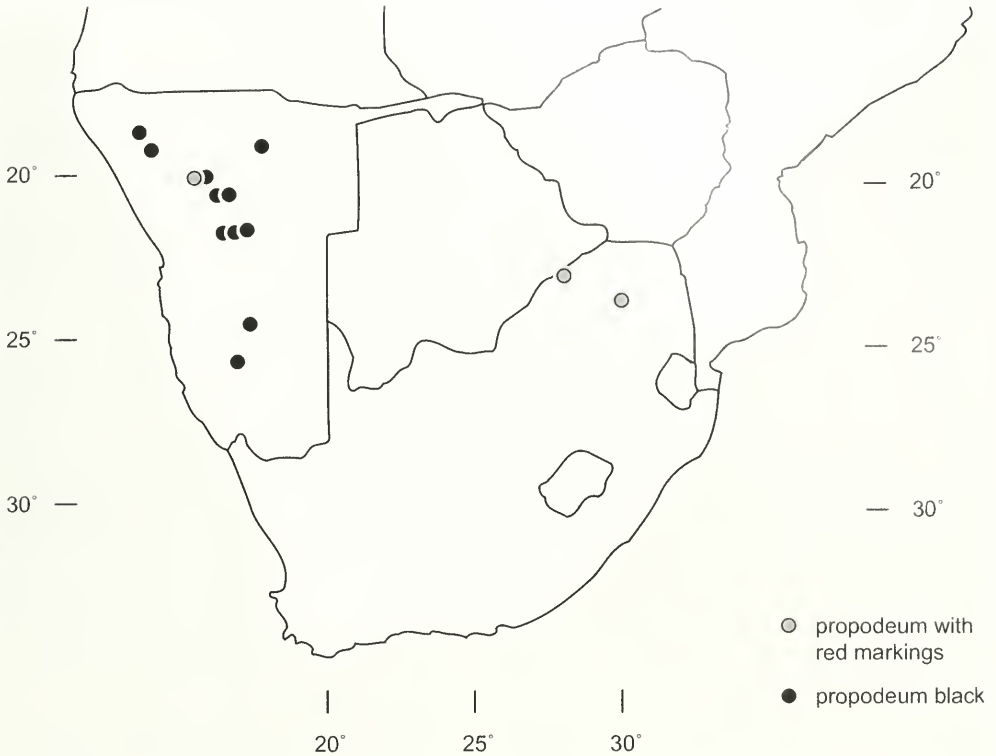

Fig. 7. *Handlirschia scoliaeformis*. Collecting localities.

One male from Namibia has been collected as prey of the asilid fly *Stiphrolamyra bipunctata* Loew. Floral records for *scoliaeformis* are: Amaranthaceae: *Hermbstaedtia odorata* (Burch.). Euphorbiaceae: *Chamaesyce glanduligera* (Pax) Koutnik. Molluginaceae: *Limeum argute-carinatum* Wawra and Peyr., and *L. myosotis* E. Walter.

**Geographic Distribution** (Fig. 7).—Namibia and Northern Province of South Africa.

**Material Examined** (FSG is used here as an abbreviation for F.W. and S.K. Gess).—**NAMIBIA: Karibib District:** 84 km W of Okahandja on road to Karibib (21.55S 16.08E), 2 Apr 1997 (visiting deep pink flowers of *Hermbstaedtia odorata* (Burch.) T.Cooke, Amaranthaceae), FSG (3 males, AMGS). **Kavango Gebied:** 100 km SW Rundu (17.56S 19.46E), 25 Jan 1993 (1 female, MS). **Khorixas District:** 44 km from Helmeringhausen on road to Spes Bona

(25.48S 16.23E), 16 Mar 1997 (visiting white flowers of *Limeum myosotis* E. Walter, Molluginaceae), FSG (2 males, 1 female, AMGS), same data, but prey of male *Stiphrolamyra bipunctata* Loew (Diptera: Asilidae) (1 male, AMGS), same locality, 17 Mar 1997 (visiting white flowers of *Limeum myosotis* E. Walter, Molluginaceae) (1 male, AMGS), same data (visiting flowers of *Chamaesyce glanduligera* (Pax) Koutnik, Euphorbiaceae) (1 male, 1 female, AMGS). **Kaross** (19.30S 14.20E), "[South African] Mus. Exped.", Feb 1925 (paralectotype female, SAM). **Maltahöhe District:** Nomtsas (24.25S 16.51E), 18 Mar 1997 (visiting white flowers of *Limeum argute-carinatum* Wawra and Peyr., Molluginaceae), FSG (1 female, AMGS). **Okahandja District:** Leeu River, 9 km W Okahandja (21.58S 16.50E), 13 Feb 1996, W.J. Pulawski (1 female, CAS); 30 km W Okahandja (21.55.56S 16.31.61E), 1500m,

Malaise-trap, 2–5 Mar 1997, M.O. Niehuis (7 males, 11 females, OHL; 1 male, 1 female, CSE). **Opuwo District:** Warmbad (= Warmquelle, 19.10S 13.49E), Koakoveld (probably a misspelling of Kaakoveld), "[South African] Mus. Exped.", Feb 1925 (types of *scoliaeformis* (paralectotypes here designated): lectotype male, 2 paralectotype males, paralectotype female, SAM). **Otjiwarongo District:** 18 mi NE Kalkfeld (20.45S 16.16E), 22 Feb 1996, W.J. Pulawski (2 males, 6 females, CAS; 1 female, BMNH); 25 km NE Kalkfeld (20.41S 16.18E), 27 Feb 1996, W.J. Pulawski (2 females, CAS); 15–20 km NW Otjiwarongo, 3 Mar 1990, W.J. Pulawski (2 males, 4 females, CAS). **Outjo District:** 24 km S Kamanjab, 5 Mar 1990, W.J. Pulawski (1 female, CAS); 18 km by road C40 from road C38 (20.02S 15.55E), 29 Mar 1997 (flying low amongst grass), FSG (1 female, AMGS). **Tsumeb District:** 10 km SE Tsumeb (19.13S 17.42E), 8 Mar 1990, W.J. Pulawski (5 males, CAS; 1 male, MS). SOUTH AFRICA: **Northern Province:** Ellisras (23.40S 27.44E), 24 Dec 1973, H.N. Empey (1 male, AMGS). Gravelotte (23.57S 30.37E), Beacon Ranch, Jan 1966, D.J. Brothers (types of *tricolor*: holotype male, 2 paratype males, paratype female (referred to as "allotype" in Gess, 1973, and labeled accordingly), AMGS; paratype male, USNM).

#### ACKNOWLEDGEMENTS

I thank Oliver Niehuis for donating Malaise-trap residues from Namibia, with twenty *Handlirschia scoliaeformis*. I also thank Maximilian Schwarz for sending *Handlirschia* from his personal collection. Fig. 1 was kindly prepared by Atılım Aynacioglu. I sincerely thank Wojciech Pulawski for sending me his synonymical and bibliographical catalog of Sphecidae. He and Fred and Sarah Gess provided information on specimens of *Handlirschia* in their collections. In particular, I thank Fred and Sarah Gess for allowing me to use their unpublished data on the life history of *Handlirschia scoliaeformis*. Wojciech Pulawski carefully checked the manuscript for spelling and consistency. My trip to South Africa was financially supported by the Deutsche Forschungsgemeinschaft DFG in the course of a project on the phylogeny and evolution of Apoidea (Wi 599/7; Rainer Willmann).

#### LITERATURE CITED

- Arnold, G. 1929. The Sphegidae of South Africa. Part XII. *Annals of the Transvaal Museum* 13:217–319.
- Bohart, R. M. 2000. A review of Gorytini in the Neotropical region (Hymenoptera: Sphecidae: Bembiinae). *Contributions on Entomology, International* 4:1–259.
- Bohart, R. M. and A. S. Menke. 1976. Sphecid Wasps of the World. A generic revision. University of California Press, Berkeley, Los Angeles, London. 1 color plate, ix + 695 pp.
- Dollfuss, H. 1989. Verzeichnis der Grabwespentypen am Naturhistorischen Museum in Wien (Hymenoptera, Sphecidae). *Kataloge der wissenschaftlichen Sammlungen des Naturhistorischen Museums in Wien. Entomologie* 7 (4):1–26.
- Gess, F. W. 1973. A new species of *Handlirschia* Kohl (Hymenoptera: Sphecidae), a very poorly known genus from South Africa. *Annals of the Cape Provincial Museums (Natural History)* 9: 103–107.
- Handlirsch, A. 1889. Monographie der mit Nysson und Bembex verwandten Grabwespen. IV. *Sitzungsberichte der Kaiserlichen Akademie der Wissenschaften. Mathematisch-Naturwissenschaftliche Classe. Abtheilung I* 98:440–517, pl. I-II.
- Horn, W., I. Kahle, G. Friese, and R. Gaedike. 1990. *Collections Entomologicae*. Akademie der Landwirtschaftswissenschaften der DDR, Berlin. 573 pp.
- Kohl, F. F. 1897. Die Gattungen der Sphegiden. *Annalen des k.k. Naturhistorischen Hofmuseums* 11 (1896):233–516, pl. V-XI. [Dating after Review by A. Handlirsch. 1897. *Verh. Zool.-Bot. Ges. Wien* 47:195–196, and Menke and Bohart. 1979. *Proc. Entomol. Soc. Wash.* 81:111–124]
- Leistner, O. A. and J. W. Morris. 1976. Southern African Place Names. *Annals of the Cape Provincial Museums* 12: 1–565.
- Melo, G. A. R. 1999. Phylogenetic relationships and classification of the major lineages of Apoidea (Hymenoptera), with emphasis on the crabronid wasps. *Scientific Papers. Natural History Museum of the University of Kansas* 14:1–55.
- Nemkov, P. G. and A. S. Lelej. 1996. Phylogenetic relationships and classification of the digger wasps tribe Gorytini (Hymenoptera: Sphecidae, Nyssoninae). *Far Eastern Entomologist* 37:1–14.
- Ohl, M. 1999. A revision of *Stizoides* Guérin-Méneville, 1844: taxonomy, phylogenetic relationships, biogeography, and evolution (Hymenoptera: Apoidea: "Sphecidae"). *Mitteilungen aus dem Museum für Naturkunde in Berlin, Zoologische Reihe* 75:63–169.
- Smith, E. L. 1970. Evolutionary morphology of the external insect genitalia. 2. Hymenoptera. *Annals of the Entomological Society of America* 63:1–27.
- Steetz, J. 1848. Nekrolog: Wilhelm von Winthem. *Entomologische Zeitung, Stettin* 9:104–198 (with a postscript by Germar about the possibility to purchase the collection, p. 198).

## Nesting Biology of *Isodontia costipennis* (Spinola) (Hymenoptera: Sphecidae)

LOURDES A. SOARES, LORENZO R. S. ZANETTE, HÉLCIO R. PIMENTA<sup>1</sup>, ALDO GONÇALVES,  
AND ROGÉRIO P. MARTINS

Laboratório de Ecologia e Comportamento de Insetos -ICB, Universidade Federal de Minas Gerais, P. O. Box: 486, Belo Horizonte, MG, Brazil (RPM E-mail: wasp@mono.icb.ufmg.br)

---

*Abstract.*—During two years (10/92–10/93 and 10/95–10/96) the nesting biology of *Isodontia costipennis* (Spinola) was studied using trap nests in four distinct areas in the Campus of the Universidade Federal de Minas Gerais (UFMG), Belo Horizonte, M.G., Brazil. Females built linear series of one to six brood cells, weakly separated by wads of grass stems and filled with plant material (grass stems and fibers). Cells were provisioned mostly with nymphs of Tettigoniidae and Gryllidae. Wasp's eggs were laid on the cephalothoracic junction of the prey. The number of prey per nest varied from 1 to 18. Sixty-one adult wasps emerged from the 41 occupied trap nests (69% females, 31% males) and the sequence of sexes in the cells was variable. Thorax widths of females were significantly larger than males (respectively  $2.63 \pm 0.22$  mm and  $2.37 \pm 0.20$  mm). An ichneumonid wasp (*Messatoporus* sp.) was the only natural enemy found.

---

*Isodontia* (Patton) is a cosmopolitan genus of solitary non-fossorial wasp that includes 60 species (Hanson and Gauld 1995). Females of this genus build their nests in natural cavities using many plant materials such as grass stems, flower pappus, moss and bits of wood; in one species bits of soil and charcoal are also used (Evans and Eberhard 1970; Bohart and Menke 1976). A number of important studies using the trap-nest method have been done on some species of *Isodontia* (Medler 1965; Lin 1966; Krombein 1967). In addition, Piel (1933) studied in detail the Oriental species *Isodontia nigellus* (Smith). However, information about the Neotropical *Isodontia* species is scarce (Bohart and Menke 1976), especially for *Isodontia costipennis* (Spinola). The earlier reports on this species referred only to glimpses of nest construction and provisioning (Richards 1937; Berland 1929; Lin 1966). Here we present new biological in-

formation about *I. costipennis*, especially on nesting behavior.

### MATERIALS AND METHODS

*Study sites.*—This study was done on the Campus of the Universidade Federal de Minas Gerais (19°52'S, 43°58'W 830 m), Belo Horizonte-MG, Brazil. The trap nests were placed in two different successional sites. Between October 1992 and October 1993 the nests were placed in the "Estação Ecológica" (site I), a preserved area since 1969, that contains two secondary growth forest fragments, more than 40 years old, one "cerrado" fragment, one marshy area and one grassland small area.

From October 1995 to October 1996 a non-preserved area, also in the UFMG's campus, the "Prefeitura" (site II), was used for the observations. This area has some remains of forest, grassland and cerrado mixed with exotic and ornamental species.

*Sampling.*—Data were collected using trap nests ( $n = 4800$ ), made of pieces of bamboo canes (*Phyllostachys* sp.) 84 to 180

---

<sup>1</sup>In memoriam.

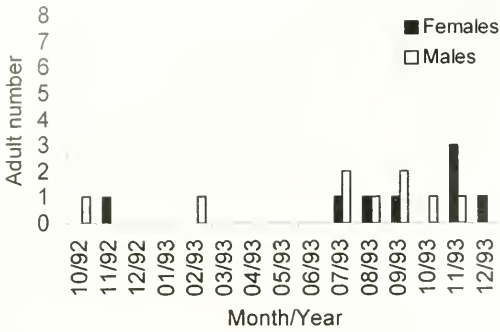

Fig. 1. Number of adult *Isodontia costipennis* emerging from the 13 nests of site I.

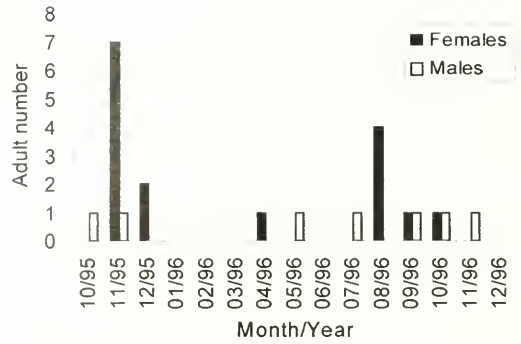

Fig. 2. Number of adult *Isodontia costipennis* emerging from 28 nests of site II.

mm long and with 76 to 241 mm of internal diameter. The bamboo cylinders were transversely cut to provide a removable cover that allowed observations on larval development (Fig. 3). One side was closed using clay, and a hole of approximately 6.5 mm was left in the other side.

The trap nests were attached horizontally to wood sticks and trees at one and two meters height, forming two plots of 600 sampling points in each studied area, one in the forest fragment and one in the cerrado fragment. Each sampling point had two trap nests (at 1 and 2m high), and was 10 meters away from the others. Each plot covered an approximate area of 5000m<sup>2</sup>.

All the nests were inspected monthly, and the occupied nests were collected and replaced by empty ones. In the laboratory, the collected nests were placed in transparent glass tubes closed with gauze and daily observed.

Emerged adults of *I. costipennis* were sexed and their thorax width was measured with a digital pachymeter. This measurement was taken as the maximum distance between the external margins of the tegulae. After that, they were pinned and placed in the UFMG's Insect Ecology and Behavior Laboratory reference collection.

*Analysis.*—All the analyses were carried out with Statistica for Windows (version 4.3). The differences between internal di-

ameters of occupied and non-occupied nests and between thorax width of males and females were tested by Student's t-test (Sokal and Rohlf 1995). The correlations between the nests length and diameter with thorax width; cocoon length; diameter and number of cells per nest were tested by Pearson's Correlation test. Differences between the amount of occupied nests at 1 and 2 meters high and proportion of sexes were tested using Pearson's Chi square.

## RESULTS

*Isodontia costipennis* occupied 13 trap nests in site I ( $\cong 0.3\%$  out of 4800), 10 were at 1m high and 3 at 2m high. Twenty-eight nests were occupied in site II ( $\cong 0.6\%$  out of 4800), 18 at 1 m high and 10 at 2 m. There were no differences between the number of occupied and non-occupied nests at each height, both, within sites and between them ( $p = 0.41$ ). In both areas only one generation of *Isodontia costipennis* per year was observed. Twelve females and 9 males emerged from the nests of site I and 30 females and 10 males from the nests of site II (Figs. 1 and 2). No differences were found between the number of males and females emerged from each site ( $p = 0.15$ ). Nests containing both sexes were found and the sequence of sexes in the cells was variable (Table 1).

The average internal diameter of the occupied nests of site I was  $12.86 \pm 3.84$  mm

Table 1. The sex sequences of adults of *Isodontia costipennis* reared from trap nests (M = male, F = female, \* = sex unknown).

Nest number	Date of emergence	Cells per nest					
		1	2	3	4	5	6
1	5/8/92	M	F	F			
2	5/20/92	F	M	M			
3	7/3/96	F	M	M			
4	8/5/96	F	F	F			
5	10/26/95	F	F	F			
6	7/29/93	F	F	F			
7	7/29/93	F	F	F			
8	10/26/95	M	F	F			
9	8/7/96	F	F	M			
10	7/2/96	M	F	M			
11	10/26/96	F	F	*	F		
12	10/27/96	M	F		F		
13	8/7/96	M	M	*	F		
14	5/29/96	M	M		F	M	
15	5/29/96	F	F		F	F	M
Females per cell (%)		60	73	60	100	50	0

(range: 9.4–24.1 mm) and  $10.57 \pm 1.37$  mm (range: 8.1–13.1 mm) to the nests of site II. No differences were found between sites ( $p = 0.0007$ ). Non occupied-nests from site II presented internal diameters ( $14.92 \pm 2.86$  mm) larger than the occupied ones ( $p = 0.0000$ ), however no differences were found at site I.

The average size of females from site I was bigger than the males ( $2.52 \pm 0.2$  mm;  $2.33 \pm 0.19$  mm;  $p = 0.04$ ). No differences were found between sizes of adults emerged from nests of site II ( $2.62 \pm 0.28$  mm;  $2.46 \pm 0.19$  mm;  $p = 0.09$ ). No correlation was found between the internal diameter of occupied nests and the adults thorax width ( $r = -0.05$ ;  $p = 0.6$ ).

*Nest construction.*—The females of *Isodontia costipennis* start nest construction, building a plug of tightly coiled plant material. Normally, two parts can be distinguished in this plug, the first one made of small coiled shoot leaves (average length of the plug and standard deviation =  $11.83 \pm 6.99$  mm;  $n = 10$ ) and the second made of tightly coiled leaf hairs ( $12.74 \pm 5.35$  mm;  $n = 10$ ). However some nests ( $n = 5$ ) did not exhibit one of these parts.

Subsequently, cells are constructed with sparsely coiled leaf hairs and the divisions between cells are made of compact plugs of leaf hairs (less compact than the initial plugs). The length of the divisions ranged from 5.5 to 23.26 mm ( $n = 11$ ); in 6 nests a single undivided cell was observed. The number of cells per nest varied from 1 to 6; 48% of them presented 2 cells. No correlation was found between the number of cells per nest and their length ( $r = 0.28$ ;  $p = 0.3$ ). An empty cell near the entrance was found in 4 nests. Nest closure is done with another plug of firmly coiled leaf hairs (average length and standard deviation =  $19.03 \pm 2.92$  mm) followed by loosely coiled leaf bits and ended with grass stems or dry brushwood tufts that can protrude until 30 mm from the entrance hole (Fig. 3).

*Nest provisioning.*—The number of prey per nest ranged from 1 to 18 ( $n = 21$ ), usually nymphs of one of the following Ensifera: Agraecidae, Copiphoridae and Phaneropteridae. In one nest an adult of Trygonidiidae (Grylloidea) was found. Only in two occasions, nests with mixed prey were found (Trygonidiidae and Copiphor-

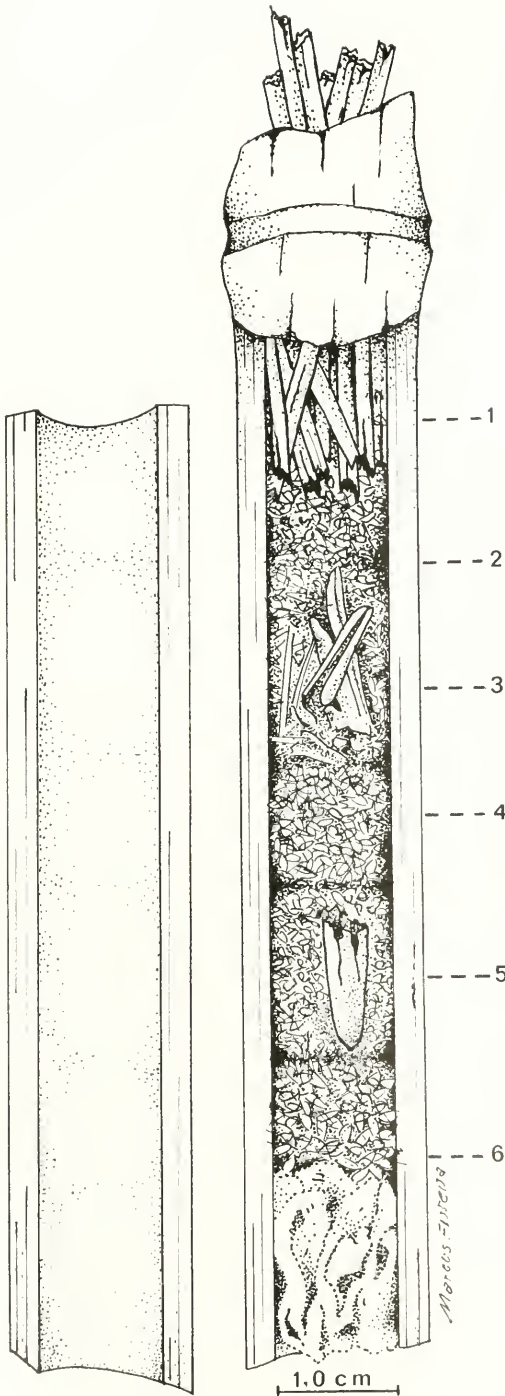

Fig. 3. Trap nest occupied by *Isodontia costipennis* (1. dry brushwood tuft; 2. closure plug; 3. cell with prey; 4. cell division; 5. cell with empty cocoon; 6. initial plug).

idae; Copiphoridae and Phaneropteridae). Six unconsumed prey (nymphs) remained alive and paralyzed over 7 days. Prey were placed venter up and the wasp's eggs were laid on their ventral cephalothoracic junction.

*Larval behavior.*—All the observed larvae ( $n = 15$ ) were active, constantly twisting and moving their heads up and also opening and closing their mandibles until they touched the prey, then starting to consume them by biting their mesothoracic venter. Generally the larvae left behind only legs and heads of adults or nymphs in the last instar.

On three occasions, larvae were observed moving from one cell to another. Once a larva, after eating all the prey in its cell, moved to a contiguous cell where there was a cocoon already and ate the remaining prey that was there before spinning its own cocoon. In three others nests two cocoons were found in the same cell.

*Immature instars.*—Egg to adult development lasts 48 to 55 days in laboratory uncontrolled conditions. The eggs hatched in 1 to 3 days, and larvae took 5 to 12 days to start spinning their cocoons. The adults took 26 to 48 days to emerge. The cocoons were 15 to 17 mm long and 5 to 6 mm wide and were always positioned with their larger part toward the nest entrance. They had two layers, an internal brownish chitinous one and an external whitish filamentous one. No correlation was found between the cocoon size (diameter) and nest size ( $r = 0.12$ ,  $p = 0.13$ ). Almost 25% of the immatures did not attain the adult stage.

*Interaction with other insects.*—Seven individuals of one species of Ichneumonidae wasp (*Messatoporus* sp.) were found in 5 nests of *I. costipennis*, 2 from site II and 3 from site I. In two other nests from site II, 1 unidentified adult coleopteran was found with remains of *I. costipennis*' cocoons. Nests from both sites were found containing ants (*Camponotus* spp.), however only in one nest from site I evidences

of ant attack were found. Two males of *Megachile* (*Pseudocentron*) *curvipes* (Smith) emerged from the same nest that one female of *I. costipennis* emerged.

### DISCUSSION

*Isodontia costipennis* seems to be a locally rare species considering that only 0.3% (site I) and 0.6% (site II) of the trap nests were occupied. However, the differences between the width of occupied and non-occupied nests suggest that the females of *I. costipennis* may prefer nesting cavities of specific size. Hence, considering that most of the unoccupied nests (78%) had an internal diameter bigger than the occupied nest average diameter, it may be assumed that nest width was a limiting factor for female selection. Fifty-eight percent of the trap nests occupied by *Isodontia mexicana* had an internal diameter of 6.4 mm and thirty-nine percent had an internal diameter of 7.9 mm (Medler 1965). The same author suggests that 4.8 mm would be the minimal diameter of the possible occupied nests. Such preferences probably could be related to the major efforts required by the females on the nest construction (Ainslie 1922; Evans 1959). The differences in size between males and females, found only in wasps emerged from nests of site I, may be related to the small number of occupied nests and therefore not be a pattern for this species. Further studies will be required to elucidate that question.

The architecture of the observed nests of *I. costipennis* is similar to those from other species in the genus. Like *I. nigella* and *I. pelopoiiformes*, *I. costipennis* occasionally builds nests that could be considered intermediate between the unilarval multicellular nests (as in *I. elegans*), and the multilarval unicellular ones (as in *I. auripes*). In those nests, cell divisions are not well defined and more than one larva can be found in some cells (Bohart and Menke 1976). Like *I. nigella* and *I. elegans*, *I. costipennis* builds (sometimes) multicellular nests with well defined partitions and a

single larva per cell (Piel 1933; Krombein 1967). The variety of nest types and materials used in nest construction presented by *I. costipennis* was also noted for *I. nigella* by Piel (1933) who presumed that a relation between the materials used and local availability of certain plants might exist. Richards (1937) describes a nest of *I. costipennis* in a large curled-up leaf, with cells not clearly divided and filled with plant wool. The empty cells that were found near the entrances of four nests probably are vestibular. This type of cell may have served, in one period of nest evolution, to discourage parasites and predators from penetrating the stored cells (Krombein 1967).

The utilization of Agraecidae, Copi-phoridae and Phaneropteridae nymphs as prey has already been described for *Isodontia* (Berland 1929; Medler 1965; Lin 1966). However the provisioning, even if casual, with adults of Trigonidiidae, is a new observation for *I. costipennis*. The number of prey placed in each cell by *I. costipennis* also did not differ from other *Isodontia* species. Bohart and Menke (1976) and Rau (1935) suggested that the number of prey per larva probably varies according to the size of the former. The variety of prey types used by *I. costipennis*, may be directly related with the local availability of prey (see Engelhardt 1928 and Medler 1965 for to other *Isodontia* spp.). The mass provisioning and occasional mixed prey nests observed in *I. costipennis* are also commonly found in the genus (Piel 1933; Medler 1965).

The relatively low number of parasites founded in the studied nests, is atypical of other *Isodontia* species. Five families of Diptera and three of Hymenoptera are commonly found parasitizing nests of *Isodontia* (Bohart and Menke 1976). Medler (1965), founded that 15% of the trap nests used by *I. mexicana* produced parasites Sarcophagidae and Phoridae. Piel (1933) mentioned that some Stylopidae parasitize *I. auripes*, *I. harrisi*, *I. nigella* and *I. costipen-*

*nis*, and are frequently found in the oriental species *I. nigella*, but rarely in the South American species. No stylopized nest was found in the present study. However, the small number of parasites found in the nests of *I. costipennis* may be only a result of the small number of trap nests occupied. Mixed nests with *Megachile* were also reported for *I. mexicana* (Medler 1965).

The record of a single generation a year is also uncommon for *Isodontia* (Bohart and Menke 1976; Rau 1935). However, considering that in this study all the occupied nests were removed to the laboratory the length of development may have been changed. The high number of dead immature may also be related with to nest transference from field to laboratory. Like other species of the genus, sex sequences in the nests of *I. costipennis* were variable (Medler 1965), but unlike other *Isodontia* spp., nests containing both sexes had cells with males preceding the cells with females.

The nesting behavior of *Isodontia costipennis* is thus very similar to that of other *Isodontia* spp. However some distinguishable aspects such as the utilization of Trigonidiidae as prey, the existence of only one generation a year and the "male before female" sex sequences in the nests, should be noted. Although *I. costipennis* seems to be a locally rare species, further studies are required to elucidate this supposition.

#### ACKNOWLEDGMENTS

Sérvio Túlio Pires Amarante identified *I. costipennis*, Alejo Mesa the Orthoptera, Fernando Amaral da Silveira identified *Megachile* (*Pseudocentron*) *curvipes*, and Alice Fumi Kumagai identified *Messatoporus* sp. Frederico Drumond Martins helped in the field. Mar-

cus Ferreira drew the trap nest (Fig. 3). Except for H. R. Pimenta, authors have scholarships from CNPq and Capes. FAPEMIG provided financial support. This is a contribution of the Program in Ecology and Wildlife Management of the Federal University of Minas Gerais.

#### LITERATURE CITED

- Ainslie, C. N. 1922. Note on the nesting habits of *Chlorion elegans*. *The Canadian Entomologist*, 269-270.
- Berland, L. 1929. Notes sur les Hyménoptères de France. *Bulletin de la Société Entomologique de France* 63-67.
- Bohart, R. M. and A.S. Menke. 1976. *Sphecidae Wasps of the World, a generic revision*. University of California Press, Berkeley, 695 pp.
- Engelhardt, G. P. 1928. An observation on the breeding habits of *Chlorion harrisi* in Texas (Hymenoptera). *Bulletin of the Brooklyn Entomological Society* 23: 269-271.
- Evans, H. E. 1959. *Isodontia*, the grass carrying wasp. *Nature Magazine* 52: 237-239.
- Evans, H. E. and M. J. W. Eberhard. 1970. *The Wasps*. University of Michigan, Ann Arbor, 265 pp.
- Hanson, P. E. and I. D. Gauld. 1995. *The Hymenoptera of Costa Rica*. Oxford University Press, 899 pp.
- Krombein K V. 1967. *Trap-nesting Wasps and Bees: Life Histories, Nests and Associates*. Washington, D.C. Smithsonian Press, 570 pp.
- Lin, C. S. 1966. Bionomics of *Isodontia mexicana*, with a review of generic ethology (Hymenoptera: Sphecidae:Sphecinae). *The Wasmann Journal of Biology* 24(2): 239-247.
- Medler, J. T. 1965. Biology of *Isodontia* (*Murrayella*) *mexicana* in trap nests in Wisconsin (Hymenoptera: Sphecidae). *Annals of the Entomological Society of America* 58(2): 137-142.
- Piel, O. S. J. 1933. Recherches biologiques sur les Hyménoptères du Bas Yang-Tse (Chine). *Annales de la Société Entomologique de France* 102: 109-154.
- Rau, P. 1935. The grass-carrying wasp, *Chlorion* (*Isodontia*) *harrisi* Fernald. *Bulletin of the Brooklyn Entomological Society* 30: 65-68.
- Richards, O. W. 1937. Results of the Oxford University Expedition to British Guiana, 1929. Hymenoptera, Sphecidae and Bembecidae. *Transactions of the Royal Entomological Society* 86: 101-118.
- Sokal, R. R. and F. J. Rohlf. 1995. *Biometry*, 3<sup>rd</sup> ed., W. H. Freeman & Co., New York, 887 pp.

## Ultramorphology and Histology of the Foregut and Midgut of *Pachycondyla* (= *Neoponera*) *villosa* (Fabricius) Larvae (Formicidae: Ponerinae)

FLÁVIO HENRIQUE CAETANO AND FERNANDO JOSÉ ZARA

(FHC) Departamento de Biologia, Instituto de Biociências—Universidade Estadual Paulista—UNESP, P.O. Box 199, 13506–900 Rio Claro (SP), Brazil; E-mail: fcaetano@rc.unesp.br; (FJZ) Departamento de Biologia, Faculdade de Ciências e Letras—Universidade Estadual Paulista—UNESP, P.O. Box 335, 19806–900 Assis (SP), Brazil; E-mail: fjzara@rc.unesp.br.

---

*Abstract.*—We studied the foregut and midgut of larvae of *Pachycondyla* (= *Neoponera*) *villosa* (F.) using histological methods and the scanning electronic microscope. In this paper we discuss the muscle layers of these regions, the origin of peritrophic matrix, the digestive cells secretion process, and the term proventriculus used in larvae.

---

The digestive tract of hymenopteran larvae consists of the pharynx, esophagus, proventriculus, ventriculus and ileum (Wheeler 1926, Nelson 1924, Wheeler and Wheeler 1976). When compared to the adult digestive tract, the major difference is that the foregut of the larva has no crop and in the hindgut there is no clear difference between ileum and rectum. The larval hindgut consists of a short and narrow tube which widens at the end. The Malpighi tubules open into the anterior portion of the ileum.

The ventriculus occupies most of the larval body and represents the major portion of the gut both in terms of length and diameter. The peritrophic matrix, which is well developed in larvae, is practically absent in adults, where it is found in few cases (Caetano 1988, Caetano et al. 1986/1987, Caetano and Hoffmeister 1987, Caetano et al. 1994).

The major objective of the present study is to describe some ultramorphological and histological aspects of larvae foregut and midgut of the *Pachycondyla villosa* (F.)

and to present some ontogenetic considerations.

### MATERIALS AND METHODS

For ultramorphology study, *P. villosa* larvae were dissected in physiological saline for insects in a Petri dish covered with colored wax. The digestive tract was removed and fixed in Karnovsky fluid for 24 hours, dehydrated in an ascending alcohol series (70 to 100%), subjected to two acetone 100% baths of 15 minutes each and then critical pointed dried (Balzers CPD 030). After dehydration the material was placed on aluminum supports attached with double-faced tape and sputtercoated with gold (in sputtering Balzers SD 050). The digestive tract was examined with a Jeol P15 SEM and photographed on Neopan SS 120 film.

For historesin preparation, *P. villosa* larvae were fixed directly in 4% paraformaldehyde in phosphate buffer (0.1 M, pH 7.4). The material was then dehydrated in 70, 80, 90 and 95% ethanol solutions for 20 minutes and transferred to resin solution (JB4—Polaron Instruments/Bio Rad) for

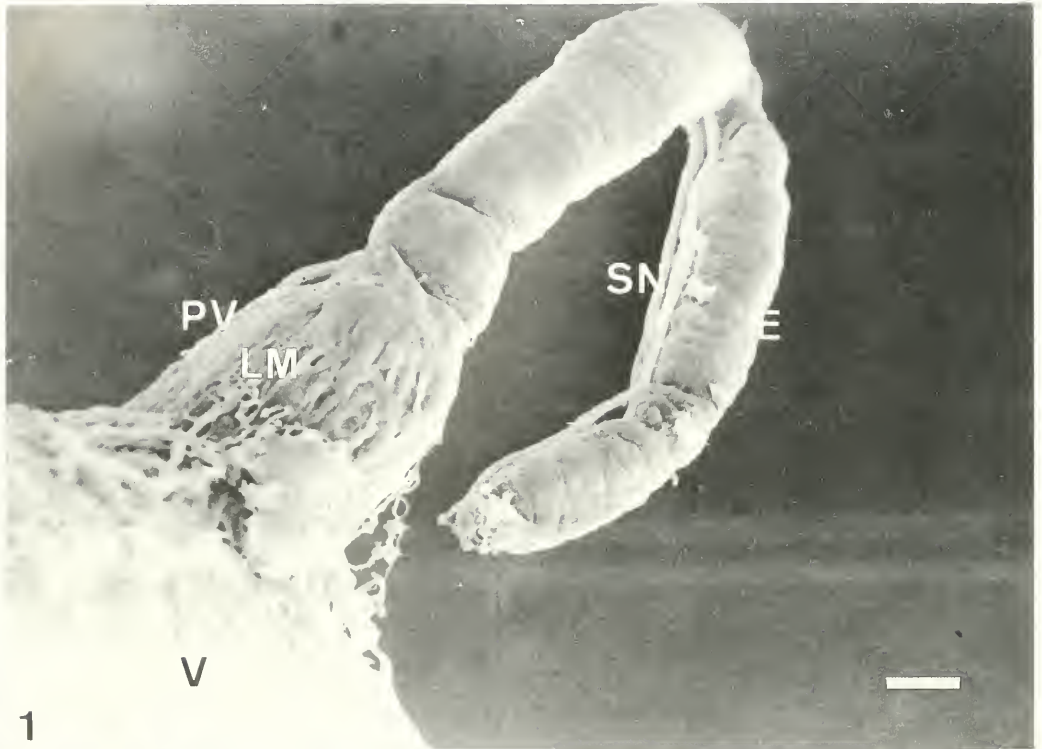

1

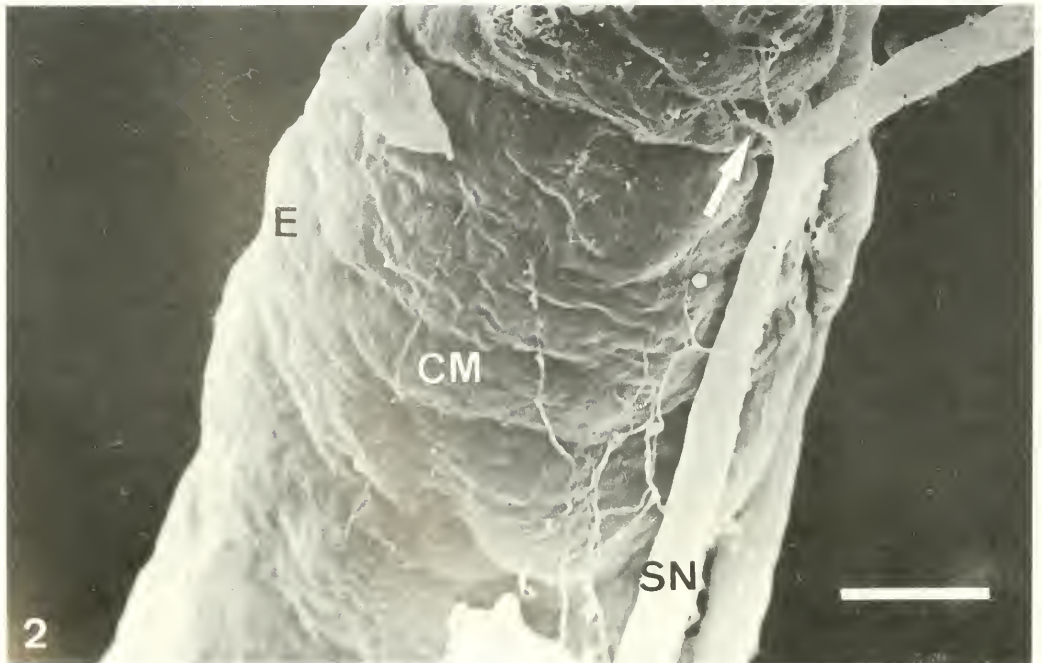

2

Figs. 1-2. 1, General view of foregut. E = esophagus; SN = stomogastric nerve; LM = longitudinal muscle; PV = proventriculus; V = ventriculus. Scale bar = 40 $\mu$ m. 2, Detail of esophagus showing relationships with stomogastric nerve (arrow). CM = circular muscle. Scale bar = 10 $\mu$ m.

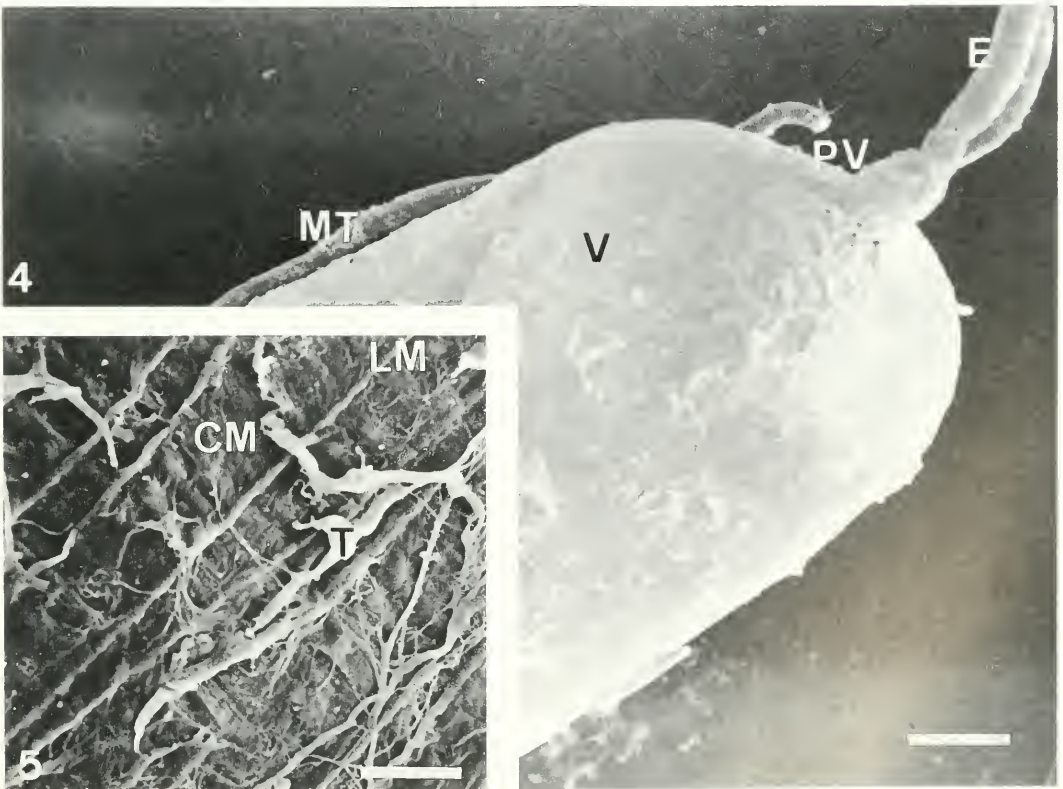
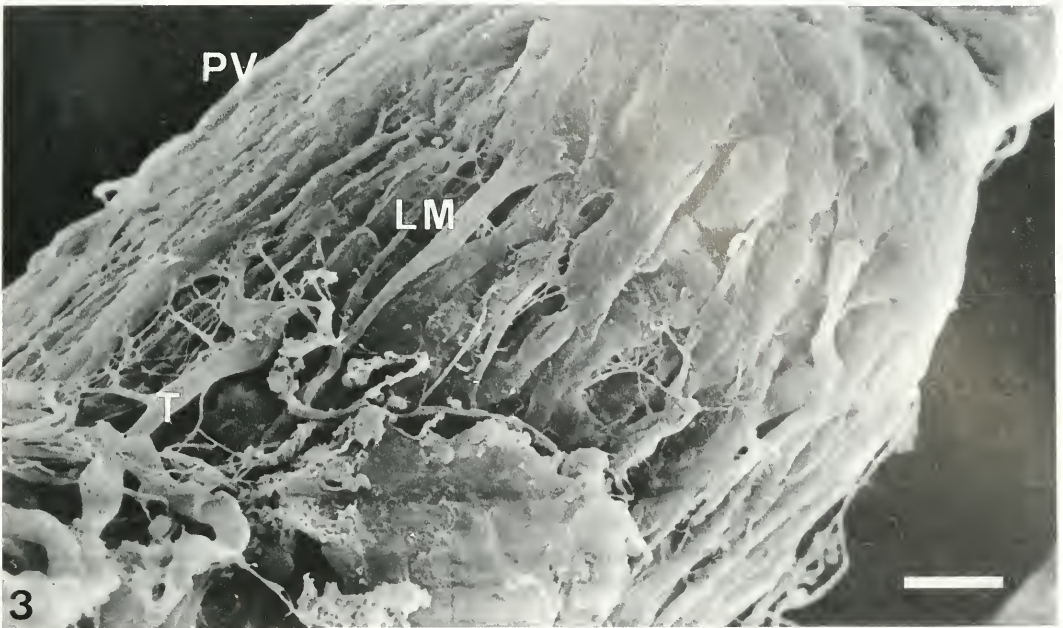

Figs. 3-5. 3, Proventriculus detail where longitudinal muscle occurs externally. Scale bar = 20 $\mu$ m. 4, General view of mesenteron (V = ventriculus). MT = Malpighian tubules. Scale bar = 200 $\mu$ m. 5, Detail of ventriculus wall showing thin and external longitudinal muscle and under these fibers the stronger circular muscle. T = trachea. Scale bar = 30 $\mu$ m.

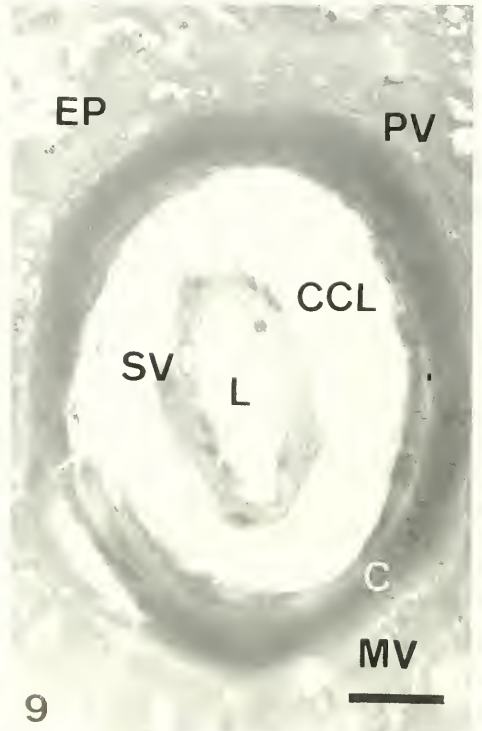
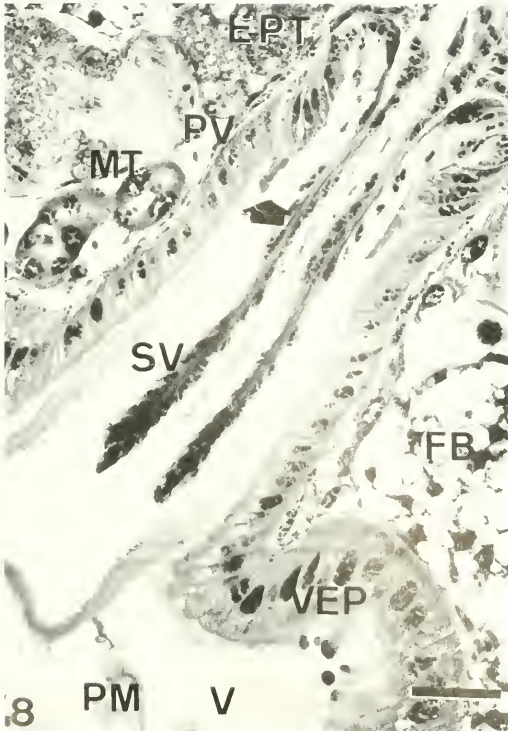
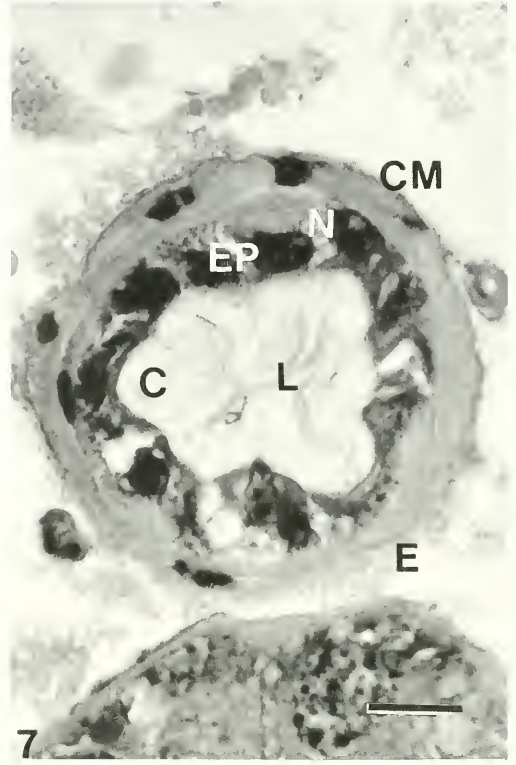
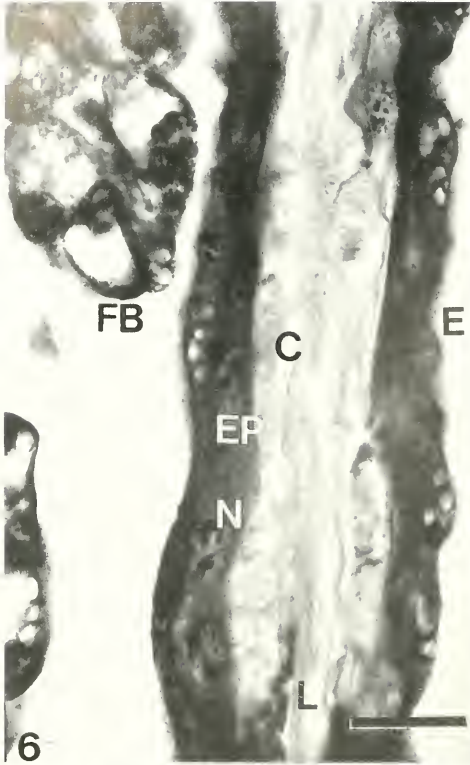

72 hours at 4°C. Finally the material was transferred to molds filled with resin containing a catalyze and sealed with metal support for microtomy. The blocks were cut in Sorvall JB4/Bio Rad microtome. The sections were stained with hematoxylin-eosin and photographed with Zeiss photomicroscope.

## RESULTS AND DISCUSSION

*Ultramorphology.*—The esophagus is a short and narrow tube that dilates near the ventriculus to form the proventriculus (Fig. 1). This region is covered with a circular muscle layer (Fig. 2) that does not resemble that observed in the adults of other ants (Caetano 1990). In the adults, the external muscle is visibly striated and consists of oblique fibers that intercross, bifurcate or anastomose. In the larvae there were no such striations or fiber separation. The image is that of a sheath covering the entire organ. The circular muscle of the esophagus stop abruptly at the anterior border of proventriculus and resemble those described to *Soleuopsis invicta* Buren (Petralia and Vinson 1980) and other ant larvae (Valentini 1951).

The stomogastric nerve runs along the entire larval esophagus towards which it emits small branches that penetrate the muscle sheath (Figs. 1 and 2), as is also observed in adults.

The proventriculus appears as a protrusion from the ventriculus surface (Fig. 1). This protrusion resembles that described by Caetano (1988), Caetano et al. (1986/

1987) and Tomotake (1990) for adults of the subfamily Ponerinae and called button. Eisner (1957) and recently Tomotake et al. (1995a,b) have shown that in adults the proventriculus may have external longitudinal muscle fibers, as also observed for some species of the subfamily Ponerinae (Tomotake 1996). The presence of these longitudinal fibers in adults suggests that they may have retained this character from larvae because the proventriculus is the only foregut region that has superficial longitudinal muscle fibers in both adults and larvae. Structurally this arrangement does not differ from typical figures of larvae presented in morphology textbooks (Wheeler and Wheeler 1976). The most clearly visible elements are the outer longitudinal muscle fibers (Fig. 3), which were also observed in this portion of the digestive tract of *P. villosa* adults by transmission electron microscopy Caetano (1991).

The ventriculus is elliptical, very wide (Fig. 4) and covered with weakly developed longitudinal muscles and connective tissue. The fibers of the circular muscle are located below these layers (Fig. 5). The location of these muscles follows the pattern known for adults of these and other ant species in which a web of amorphous connective tissue is observed (Caetano unpublished data) through which tracheal branches penetrate the ventriculus (Fig. 5).

According to Lappano (1958), Petralia and Vinson (1980) the ventriculus is the largest organ of the larva and appears to

---

←  
Figs. 6–9. 6, Longitudinal section of esophagus, showing thick cuticle (C) covering lumen. FB = fat body; L = lumen; N = nucleus; EP = esophagus epithelium. Scale bar = 10µm. 7, Transverse section in esophagus showing thick cuticle, cubic epithelium of esophagus and sheath of circular muscle. Scale bar = 20µm. 8, Section through proventriculus showing different epithelia of region. (EPT) transition epithelium, (SV) stomodeal valve epithelium and (VEP) ventricular epithelium. In this micrograph we can observe that the transition epithelium is producing the peritrophic matrix (arrow). The Malpighian tubules and the fat body are close to this region. PM = peritrophic matrix. Scale bar = 20µm. 9, Transverse section in proventriculus. MV = microvilli; SV = stomodeal valve; L = stomodeal valve lumen; C = cuticle; CCL = stomodeal chamber lumen. Scale bar = 20µm.

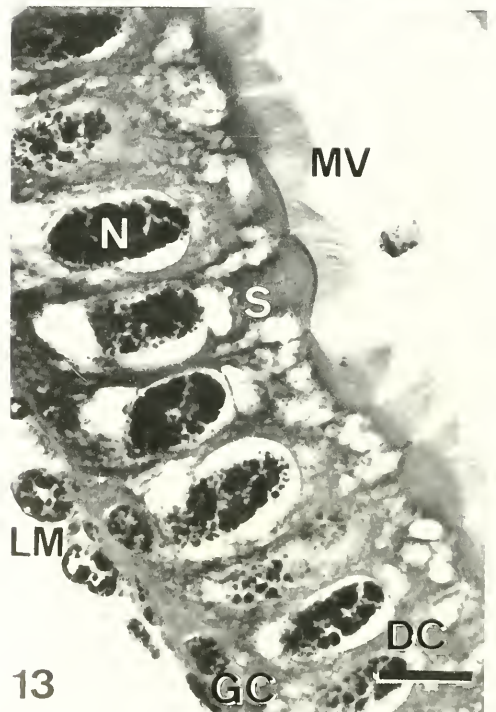
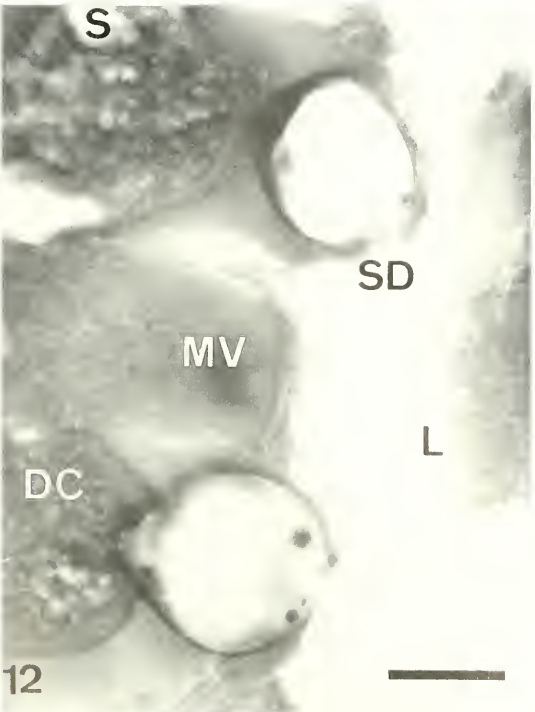
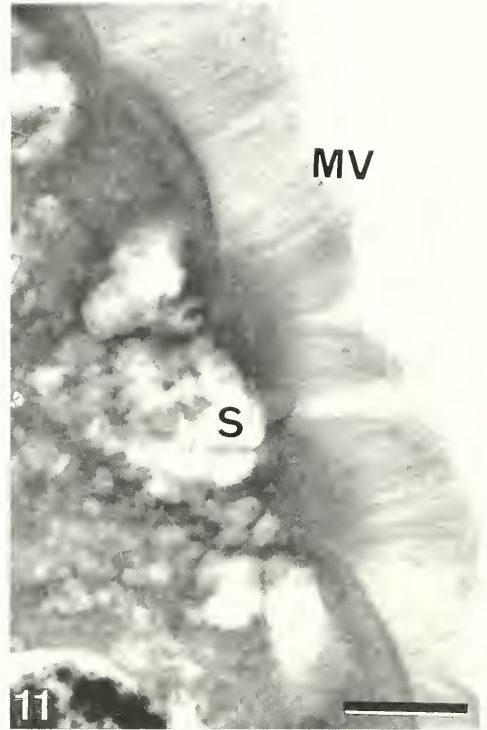
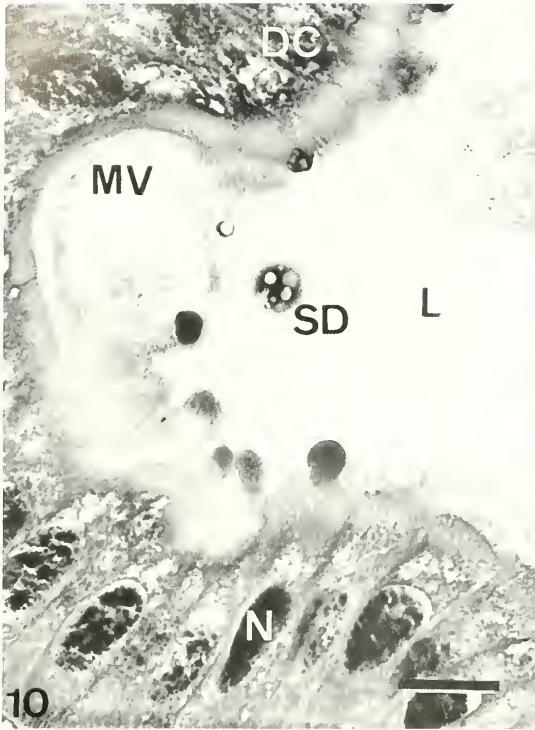

Fig. 10-13. 10, Ventriculus epithelium with digestive cells (DC); cells have large median nuclei (N) and long microvilli (MV) with smooth secretion droplets (SD) between them. Scale bar = 20µm. 11, Detail of apex of

serve as a mould around which the other abdominal organs are orientated. This suggestion is confirmed in *P. villosa* larvae.

*Histology.*—The esophagus has a wide lumen, cuboidal epithelium covered with a thick cuticle and a circular muscle sheath covering it externally (Figs. 6 and 7). During feeding, the food bolus may be transported through the esophagus by means of peristalsis, as occurs in *S. invicta* (Petralia and Vinson 1980). Except for the wide lumen and thick cuticle, this description agrees from that of adults of the same species (Caetano 1988) and of all other adult ants studied so far (Walker and Clower 1961, Caetano and Lage Filho 1982, Caetano 1984, 1988, 1990). In adults the epithelium is thin and the muscle sheath less so evident.

The proventriculus consists of columnar epithelium with basal nuclei and well developed ensheathing longitudinal muscles. This portion of the foregut has two chambers: one formed by the epithelial portion of the foregut (cardiac or stomodeal valve), and the other located between the stomodeal valve and the proventriculus wall, whose lumen communicates directly with the lumen of the ventriculus (Fig. 8).

Thus, the proventriculus of *P. villosa* larvae appears to be formed by a prolongation of the epithelium of the ventriculus towards the foregut and its internal portion, the stomodeal valve proper, is formed by a projection of the foregut towards the ventriculus (Fig. 8). Thus, these portion probably reflect a mixed developmental origin: the internal part arises from the ectoderm of the foregut and the outer part from the endoderm of the mid-

gut. The presence of outer longitudinal muscle fibers in the so-called larval proventriculus, as observed in the ventriculus, is clarified. On this basis, we believe that in larvae the structure known as proventriculus should be called "stomodeal chamber" because of its position and it harbors the stomodeal valve, in contrast with the adult proventriculus that does not have the stomodeal chamber (Caetano 1988).

The lumen of this region is lined with a thick cuticle organized in a trabecular formation, which does not resemble the cuticular arrangement of adults. The adult proventricular lining is organized into four (or more) mobile lips that are usually covered with spiniform cuticular structures (Eisner 1957, Caetano et al. 1991, 1998, Tomotake 1996).

The ectodermal origin of the stomodeal valve was indicated by the presence of cuticle that does not stain in histochemical processes for proteins, as shown in transverse sections (Fig. 9).

The ventriculus is a yellow or dark coloured region visible in live larvae. It is a blind sac posteriorly, similar to what is observed in several species of higher Hymenoptera as *Apis mellifera* L. (Nelson 1924), *Eciton burchelli* Westw. (Lappano 1958), *S. invicta* (Petralia and Vinson 1980), *Ectatomma edentatum* Roger (Zara and Caetano 1998) and some species of the subfamily Formicinae, Dolichoderinae and Myrmicinae (Valentini 1951), although Athias-Henriot (1947) reports it to be open in *Monomorium*.

The ventricular epithelium is columnar and could be identified by one type of digestive cell. This cell has distinct round or oval pycnotic nucleus located

←

digestive cells with long microvilli and secretion (S) close to apical membrane. Scale bar = 10µm. 12, Detail of secretion droplets (SD) releasing from digestive cells. Note absence of microvilli in secretion droplet. Scale bar = 10µm. 13, General view of ventriculus epithelium of old larvae showing large space around nucleus and secretion in apex. GC = Regenerative cell. Scale bar = 20µm.

between the median and basal portion of the cell (Fig. 10) similar to *E. burchelli* and *S. invicta* (Lappano 1958, Petralia and Vinson 1980, respectively). The apex of these cells is rounded, conferring a club-like shape on them, and usually appears to contain large secretion vacuoles. The border bears long microvilli (Figs. 10 and 11). The secretion is released, like a "budding" process in the form of vesicles containing granules that stain differentially with H-E (Figs. 10, 11 and 12). This process resembles that observed in the adult ventriculus of *Pachycondyla striata* Smith, but without microvilli surrounding the vesicles (Caetano et al. 1994). This kind of release secretion is different than merocrine secretion described in *Cataglyphis bombycina* (Roger) larvae (Valentini 1951). These cells could be producing digestive enzymes; however, the absorptive cells were not observed.

The nests of regenerative cells commonly present in the ventriculus of adults are not observed in larvae (Caetano 1984, 1988, 1990, Caetano et al. 1986/1987), but they occur as isolated nuclei close to the basal lamina (Fig. 13).

The peritrophic matrix is clearly visible in ventricular lumen (Figs. 14 and 15) and an accumulation of "membranes" is noted in its distal portion. Some of the membranes enclose food remains and some of them are empty (Fig. 16). In this region, the remnants of the peritrophic membrane (meconium) are accumulated for later elimination during pupation as also observed in *S. invicta* (Petralia and Vinson 1980). The anterior region of the proventriculus, more precisely the transition epithelium (Fig. 8, arrow), seems to be responsible for the secretion of the peritrophic matrix which expands soon after leaving the cardiac valve (Fig. 14) and reaches the epithelium of the ventriculus. This kind of peritrophic matrix formation is similar to that recorded for *E. edentatum* larvae (Zara and Caetano

1998). In contrast, Petralia and Vinson (1980) described a second type of peritrophic matrix produced along the entire ventriculus of *S. invicta*, but this does not occur in *P. villosa*.

In adults of some ponerine genera (e.g., *Ectatomma* and *Neoponera*), Caetano (1988) reported a similar origin of the peritrophic matrix, which at first may be confused with the stomodeal valve itself. In the adults, however, the peritrophic matrix penetrates the median region of the ventriculus and opens, appearing to originate from inside the stomodeal valve. In the larvae studied here the peritrophic matrix opens immediately upon leaving the stomodeal valve, which serves as a mold.

## CONCLUSIONS

a) The outer muscles present in the foregut and midgut of *P. villosa* larvae differ from those of adults by the absence of clearly transverse striations.

b) The proventriculus and the ventriculus of the larvae have an external longitudinal muscle sheath but only the adults ventriculus shows it.

c) The larval proventriculus is morphologically simpler than in adults; the presence of cuboidal epithelium with microvilli indicates a secretory function.

d) The proventriculus term used for adults does not seem to be appropriate for the larval structure described here, we suggest the stomodeal chamber.

e) The "button" located close to the ventriculus anterior region previously described by other authors and present in adults of the subfamily Ponerinae is similar to the upper portion of the stomodeal chamber.

f) The histological characteristics of the stomodeal chamber of larvae lead us to believe that this portion may originate from the endoderm as the ventriculus.

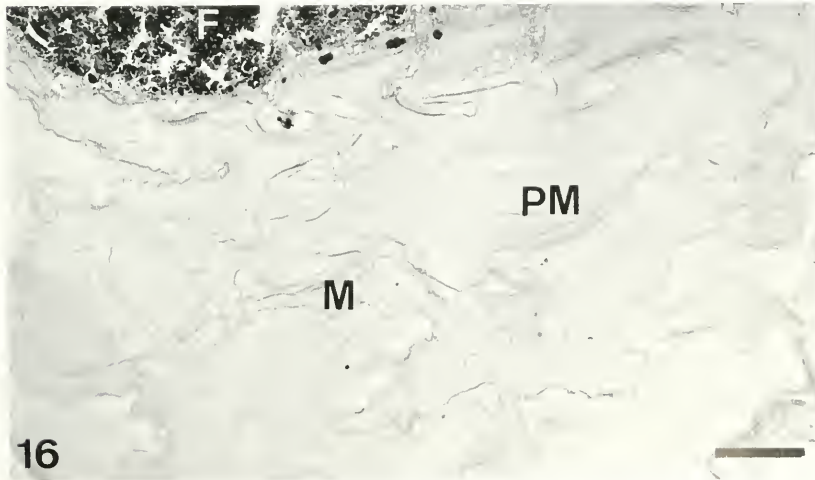
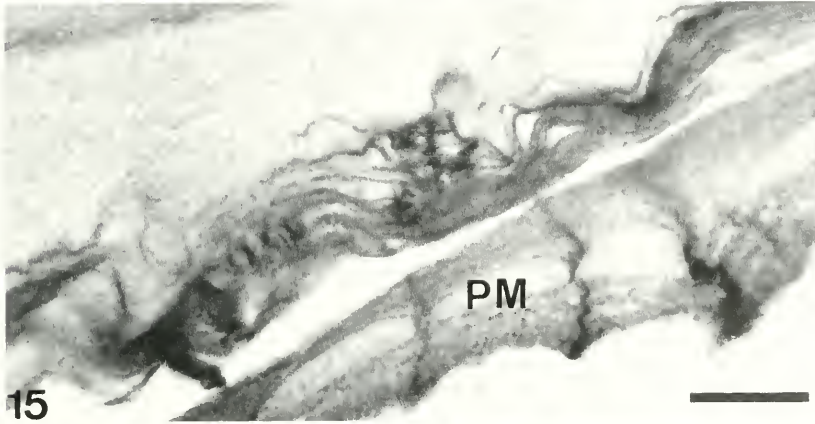

Figs. 14-16. 14, General view of ventriculus proximal region with stomodeal valve and peritrophic matrix being released. Scale bar = 10 $\mu$ m. 15, Close up of peritrophic matrix showing its layers. Scale bar = 10 $\mu$ m. 16, General view of posterior region of ventriculus with "meconium" (M). Scale bar = 50 $\mu$ m.

## ACKNOWLEDGEMENTS

This work was supported by FAPESP (Fundação de Amparo à Pesquisa do Estado de São Paulo)—Proc. 98/00576-8.

## LITERATURE CITED

- Athias-Henriot, C. 1947. Recherches sur les larves de quelques fourmis d'Algérie. *Bulletin Biologique de la France et de la Belgique* 81: 247-272.
- Caetano, F. H. 1984. Morfologia comparada do trato digestivo de formigas da subfamília Myrmicinae (Hymenoptera, Formicidae). *Papéis Avulsos de Zoologia* 35: 257-303.
- Caetano, F. H. 1988. Anatomia, histologia e histoquímica do sistema digestivo e excretor de operárias de formigas (Hymenoptera, Formicidae). *Naturalia*. 13: 129-174.
- Caetano, F. H. 1990. Morphology of the digestive tract and associated excretory organs of ants. *Applied Myrmecology*, 1: 119-137.
- Caetano, F. H. 1991. Ultraestrutura do pescoço do proventriculo de *Neoponera villosa* (Formicidae, Ponerinae). *Proceedings of the XIII Colóquio Sociedade Brasileira de Microscopia Eletrônica*, Caxambu p. 167.
- Caetano, F. H. and A. L. Lage Filho. 1982. Anatomia e histologia do trato digestivo de formigas do gênero *Odontomachus* (Hymenoptera, Ponerinae). *Naturalia*. 7: 125-134.
- Caetano, F. H., M. I. Camargo-Mathias and W. L. Overal. 1986/1987. Anatomia e histologia comparada do trato digestivo de *Dinoponera gigantea* e *Paraponera clavata* (Formicidae, Ponerinae). *Naturalia*. 11/12: 125-134.
- Caetano, F. H. and R. M. Hoffmeister. 1987. Presença de Membrana Peritrófica em *Camponotus rufipes* (Hymenoptera, Formicidae). *Proceedings of the XI Colóquio Sociedade Brasileira de Microscopia Eletrônica*, Caxambu p.91-92.
- Caetano, F. H., D. Beig and J. D. Majer. 1991. Descrição do proventriculo de *Myrmecia* sp (Formicidae, Myrmicinae) ao microscópio eletrônico de varredura. *Proceedings of the XIII Colóquio Sociedade Brasileira de Microscopia Eletrônica*, Caxambu, p. 157-158.
- Caetano, F. H., A. H. Torres, M. I. Camargo-Mathias and M. E.M. Tomotake. 1994. Apocrine secretion in ant, *Pachycondyla striata*, ventriculus (Formicidae: Ponerinae). *Cytobios* 80: 235-242.
- Caetano, F. H., X. Espadaler and F. J. Zara. 1998. Comparative ultramorphology of the proventriculus bulb in two species of Mutillidae (Hymenoptera). *Iheringia Série Zoológica* 85: 133-136.
- Eisner, T. 1957. A comparative morphological study of proventriculus of ants (Hymenoptera, Formicidae). *Bulletin of the Museum of Comparative Zoology at Harvard College* 116: 437-490.
- Lappano, E. R. 1958. A morphological study of larval development in polymorphic all-worker broods of the army ant *Eciton burckhelli*. *Insectes Sociaux* 5: 31-66.
- Nelson, J. A. 1924. Morphology of the honeybee larva. *Journal of Agricultural Research* 28: 1167-1229.
- Petralia, R. S. and S. B. Vinson. 1980. Internal anatomy of the fourth instar larva of the imported fire ant, *Solenopsis invicta* BUREN (Hymenoptera: Formicidae). *International Journal of Insect Morphology & Embryology* 9: 89-106.
- Tomotake, M. E. M. 1990. *Morfologia comparada do trato digestivo de formigas em quatro tribos da subfamília Ponerinae (Hymenoptera, Formicidae)*. Master Tesis—Rio Claro UNESP. 112p.
- Tomotake, M. E. M. 1996. *Ultra-estrutura do proventriculo de operárias da subfamília Ponerinae (Hymenoptera, Formicidae)*. PhD Tesis- Rio Claro UNESP. 129p.
- Tomotake, M. E. M., F. H. Caetano and M. I. Camargo-Mathias. 1995a. The proventriculus ring: a comparison between Ponerinae and Dolichoderinae ants subfamily (Hymenoptera, Formicidae). *Acta Microscopica*. 4: 318.
- Tomotake, M. E. M., F. J. Zara and F. H. Caetano. 1995b. A musculatura externa do proventriculo de *Neoponera villosa*: Mudança da fase larval para a vida adulta. *Proceedings of XII Encontro de Mirmeccologia*, São Leopoldo. p.99.
- Valentini, S. 1951. Sur L'adaptacion des larves de Formicoidea. *Annales Des Sciences Naturalles et Zoologie* 11: 249-276.
- Walker, J. R. and D. F. Clower. 1961. Morphology and histology of the alimentary canal of the imported fire ant queen (*Solenopsis sacivissima richteri*). *Annals of the Entomological Society of America* 54: 22-28.
- Wheeler, C. G. and J. Wheeler. 1976. Ant larvae: review and synthesis. *Proceedings of the Entomological Society of Washington*. 108pp.
- Wheeler, W. N. 1926. *Ants, their structure, development and behavior*. Columbia University, New York. 663pp.
- Zara, F. J. and F. H. Caetano. 1998. Formação da membrana peritrófica em larvas de *Ectatomma edentatum* (ROGER, 1863) (Hymenoptera: Formicidae). *Revista Brasileira de Biologia* 58: 33-37.

## Ultrastructure of Spermatozoa in *Plebeia (Plebeia) droryana* Friese (Hymenoptera: Apidae: Meliponina)

UYRÁ ZAMA, JOSÉ LINO-NETO, AND HEIDI DOLDER

(UZ, JL-N, HD) Dept. of Cell Biology, State University of Campinas (UNICAMP), Campinas, São Paulo, Brazil; (JL-N) Dept. of General Biology, Federal University of Viçosa (UFV), Viçosa, Minas Gerais, Brazil

---

*Abstract.*—In general, the spermatozoa of *Plebeia (Plebeia) droryana* Friese are very similar to those described for other Hymenoptera. However, their arrangement in spermatodesmata bundles in the seminal vesicle has not yet been found in Apidae, this being a characteristic observed, to date, only in Symphyta, the Hymenoptera considered most primitive. The spermatozoa are long and thin, made up of a head connected to the tail at the position of the centriolar adjunct. The head includes an acrosomal vesicle, a perforatorium and a electron dense nucleus. The flagellum consists in a typical axoneme, two mitochondrial derivatives and two accessory bodies. Unlike most other Hymenoptera, the centriolar adjunct is very long and located between the nuclear base and the anterior extremity of the smaller mitochondrial derivative. It has recently been demonstrated that the structure and ultrastructure of hymenopterian spermatozoa are sufficiently varied so as to furnish consistent character matrices that can contribute to phylogenetic studies ("Spermiocladistics"). Since no consensual phylogenetic hypothesis has yet been proposed for Apidae, the data presented here may be a contribution in this direction.

---

The Apidae have been extensively studied due to their economic and ecological importance, since they are pollinators, often exclusively, of the majority of flowering plants, including species cultivated by man. The relation between these pollinating agents and the plants they pollinate is so intimate that changes in the biodiversity of either group is certain to affect the other. The Apidae are also recognized as a diverse group with complex social behaviour, which culminate in advanced eusocial societies, a level observed only among Hymenoptera (a few bees and wasps) and in the Isoptera.

Within the Apidae, the tribe Apini, consisting in the subtribes Apina, Bombina, Euglossina and Meliponina (*sensu* Roig-Alsina and Michener 1993), is particularly interesting because its members collectively display all levels of social behaviour. Ranging from solitary bees, as in some Euglossina, to advanced eusocial groups,

such as the Apina and the Meliponina, passing through intermediate social behavior groupings as found in the Bombina and Euglossina.

In spite of the unquestioned importance of the Apidae, so far neither morphological nor molecular studies have been able to establish an uncontested phylogeny for this group (Camargo and Pedro 1992b; Cameron 1991, 1993; Cameron et al. 1992). The establishment of the phylogeny of this group would undoubtedly be important for studies of the evolutionary mechanism, or mechanisms, leading to eusocial behaviour (Crozier and Pamilo 1996).

Structural and ultrastructural characteristics of the spermatozoa, besides their own biological and taxonomic aspects, may be very interesting if this information can be used to form a character matrix for phylogenetic analysis. This information, associated with other character systems, could lead to a better understanding of the

evolutionary relationships within the group ("spermiocladistics", Jamieson 1987) as is being carried out for other animals, including insects (Baccetti 1972; Dallai 1979; Dallai and Afzelius 1990, 1995; Carcupino et al. 1995; Jamieson et al. 1999; Lino-Neto et al. 1999, 2000a, 2000b).

The spermatozoal ultrastructure of only one apid species, *Apis mellifera* Linnaeus, representing the Apini, has so far been studied in detail (Rothschild 1955; Hoage and Kessel 1968; Cruz-Höfling et al. 1970; Lensky et al. 1979; Woyke 1970; Lino-Neto et al. 2000b). Besides this species, in Meliponina only some aspects of spermiogenesis were investigated, including that of *Scaptotrigona postica* Latreille (Cruz-Landim and Beig 1980; Cruz-Landim et al. 1980), *Melipona quadrifasciata anthidioides* Lepeletier (Cruz-Landim et al. 1980; Cruz-Landim and Moraes 1980), *Plebeia* (*Plebeia*) *droryana* Friese, *Friescomelitta* (*Friescomelitta*) *varia* Lepeletier, *Leurotrigona muelleri* Friese (Cruz-Landim et al. 1980). However these publications contain almost no information on the mature sperm cell. Therefore, in this study, we characterize the structure and ultrastructure of *Plebeia* (*Plebeia*) *droryana* sperm so as to furnish data that could be used for future phylogenetic research.

#### MATERIAL AND METHODS

Adult males of *Plebeia* (*Plebeia*) *droryana* were obtained from colonies maintained in the Central Apiary of the Federal University of Viçosa, MG, Brazil.

*Light Microscopy.*—Seminal vesicles were dissected and broken open on clean glass microscope slides, where the sperm were spread and fixed in a solution of 4% (wt/vol) paraformaldehyde in 0.1 M phosphate buffer, pH 7.2. After drying at room temperature, the preparations were observed with a photomicroscope (Olympus, BX60), equipped with phase contrast.

To measure the nucleus, some of these preparations were stained for 15 min. with 0.2 µg/ml 4,6-diamino-2-phenylindole

(DAPI) in phosphate buffered saline, washed, and mounted with Vectashield. They were examined with an epifluorescence microscope (Olympus, BX60), equipped with a BP360–370 nm excitation filter.

*Transmission Electron Microscopy.*—Seminal vesicles were dissected and fixed for 3 hours in a solution containing 2.5% glutaraldehyde, 0.2% picric acid, 3% sucrose and 5 mM CaCl<sub>2</sub> in 0.1 M cacodylate buffer, pH 7.2. The materials were post fixed in 1% osmium tetroxide, in the same buffer, for 1–2 hours. Dehydration was carried out in acetone and embedded in Epon. Ultrathin sections were stained with uranyl acetate and lead citrate and observed with the Zeiss LEO 906 transmission electron microscope.

#### RESULTS

In the seminal vesicle, the spermatozoa of *Plebeia* (*Plebeia*) *droryana* are organized in spermatodesmata bundles, where the anterior region of the heads are embedded in a substance of medium electron density (Figs. 1, 2). The more central spermatozoa are situated slightly ahead of the lateral ones, so that a transverse section of this region shows acrosomes sectioned at different levels (Fig. 2). However, some isolated spermatozoa also appear chaotically dispersed in the seminal vesicles (Figs. 5–7).

The spermatozoan of *P. droryana* is long and thin, measuring approximately 135 µm in length (Fig. 3). The acrosome measuring about 1.2 µm and is made up of the acrosomal vesicle and the perforatorium (Figs. 1, 5–6). The acrosomal vesicle is cone-shaped and covers the perforatorium along its entire length (Fig. 6). In transverse section, the acrosome is circular at the tip but becomes triangular, particularly the perforatorium towards the nucleus (Figs. 2, 8–9). Along the circular portion, an electron transparent layer covers the perforatorium, separating it completely from the acrosomal vesicle. However,

when they are triangular this clear layer is reduced to patches at the vertices (Figs. 8–9). The perforatorium base penetrates about 70 nm into a small asymmetric cavity in the nuclear tip (Fig. 7).

The nucleus measures approximately 7.5  $\mu\text{m}$  in length and is filled homogeneously with dense chromatin. In transverse section, it is slightly oval, measuring approximately 0.18  $\mu\text{m}$  in diameter at the anterior extremity and 0.45  $\mu\text{m}$  at the posterior (Figs. 2–7, 10–13). At the anterior tip there is a cavity in which the perforatorium fits (Fig. 7), while posteriorly the nucleus tapers conically and is covered by thin electron transparent and electron dense material (Figs. 12–13, 15).

The axoneme, measuring 126  $\mu\text{m}$  in length, presents the 9+9+2 pattern of microtubules, with 9 single, external, accessory microtubules, nine doublets and a pair of single ones in the center of the arrangement (Figs. 18–21). In the first 0.28  $\mu\text{m}$ , corresponding to the centriole, the axoneme consists only of the accessory microtubules, the doublets and a dense amorphous substance (Fig. 16). The central microtubules begin posterior to the centriolar portion (Fig. 17). In the final portion, the axoneme is gradually disorganized, with the central microtubules and the nine doublets terminating first, simultaneously, followed by the accessory microtubules (Figs. 21–24).

The centriolar adjunct is very long, about 4.6  $\mu\text{m}$  in length, compact and electron dense. It begins at the nuclear base and extends parallel to the axoneme until it fits onto the smaller mitochondrial derivative (Figs. 11–14). In longitudinal section, it has a rod-like shape while in transverse section it is approximately circular, with a diameter of about 0.2  $\mu\text{m}$  (Figs. 1, 11–12, 14, 16–18).

The mitochondrial derivatives are asymmetric in both length and diameter (Figs. 11, 13–14, 19). Anteriorly, the larger mitochondrial derivative begins next to the tapering nucleus (Fig. 13) and the

smaller in contact with the posterior end of the centriolar adjunct. In transverse section, the derivatives are elipsoidal, with the larger one curving slightly over the smaller one (Fig. 19). Both have at least three regions: a dense material that fills in most of the mitochondrial derivatives; a clear approximately central area and the region of the cristae, limited to that part of the periphery opposite the axoneme (a, b and c in Figs. 16–19). The large mitochondrial derivative also has a region of regularly arranged paracrystalline material in the third that is most distal to the axoneme (p in Figs. 16–19). Anteriorly, the derivative extremities do not show any cristae (Figs. 13–14).

The accessory bodies are located laterally, between the axoneme and the mitochondrial derivatives. In transverse sections, they have a triangular shape (Figs. 18–20). In the centriolar adjunct region, there is only one accessory body present between the larger mitochondrial derivative and the axoneme (Fig. 18).

## DISCUSSION

The arrangement of spermatozoa in spermatodesmata observed in *Plebeia droryana*, has not been described for Apocrita. According to Quicke et al. (1992), this spermatozoa arrangement in bundles is characteristic of Symphyta, considered primitive Hymenoptera, in spite of some sheath fragments encountered by these authors in some Aculeata. The central spermatozoa of the sheaths are somewhat ahead of the others, as observed in *P. droryana*, as also occurs in Xyeloidea and Phamphiloidea, which are considered the most basal Symphyta (Newman and Quicke 1999a). However, in the Siricidae, considered the family most closest to Aculeata studied so far, the central spermatozoa are inserted well ahead of the peripheral ones, so that in transverse sections, they are observed in very different levels (Newman and Quicke 1999a). Although most of the spermatozoa are organized in

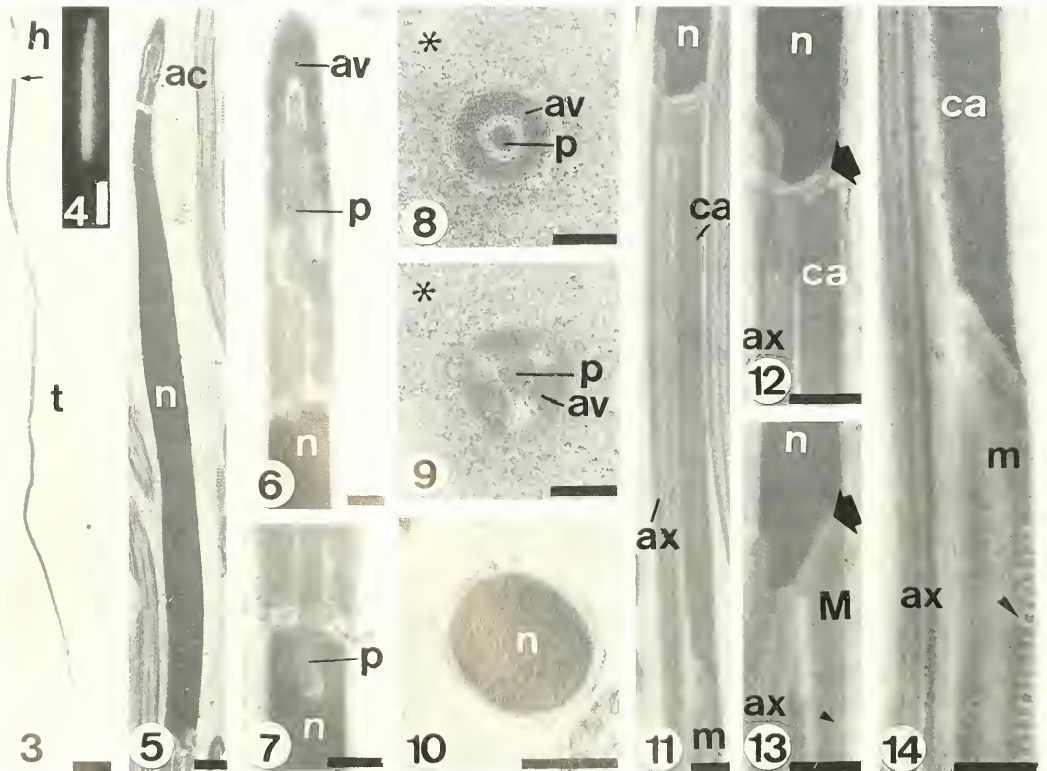
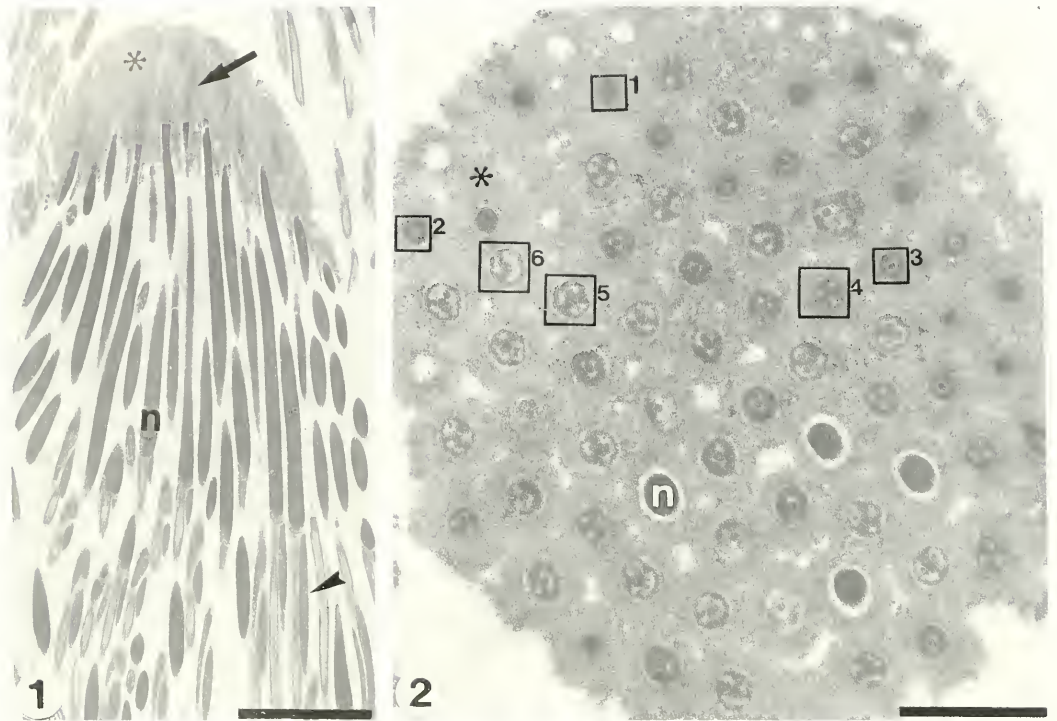

spermatodesmata in *P. droryana*, as in the symphytans, *Tremex* sp. (Newman and Quicke 1999a) and *Calameuta* sp. (Quicke et al. 1992), some spermatozoa are free. Newman and Quicke (1999a) suggested that the observation of free spermatozoa in the seminal vesicle could be due to fixation or if they indicate a pre-transfer phenomenon. We believe that it is also possible that these spermatozoa have either not yet been grouped into spermatodesmata, or even that not all spermatozoa are destined to become included in bundles.

In all the apocritan non-Aculeata (parasitic wasps) considered to date, the spermatozoa appear isolated in the seminal vesicle, and no spermatodesmata fragments have been observed (ex. Quicke et al. 1992; Newman and Quicke 1998, 1999b; Lino-Neto et al. 1999, 2000a; Lino-Neto and Dolder 2001a, b). The fact that spermatozoa organized in spermatodesmata occur in Symphyta and in at least one apocritan Aculeata, which are considered, respectively, the most basal and the most derived hymenopteran groups, while not occurring in the apocritan non-Aculeata, is very intriguing. This suggests either that it could be a reversed character state in Aculeata or that this group derived directly from the Symphyta, as is believed to have occurred with parasitic wasps. This latter hypothesis seems less likely

since morphological and molecular analyses suggest that Aculeata are the sister group of the Ichneumonoidea (Whitfield and Cameron 1998; Ronquist et al. 1999).

The basic structure of the spermatozoa in *P. droryana* is quite similar to that described for other Hymenoptera, as well as for insects in general (Phillips 1970; Bacchetti 1972). The acrosome of *P. droryana*, made up of an acrosomal vesicle and the perforatorium appears to be typical for Hymenoptera (Jamieson 1999), having been found in Symphyta (Quicke et al. 1992; Newman and Quicke 1999a), in the Scelionidae, *Trissolcus basalis* (Lino-Neto and Dolder 2000a), in Formicidae (Wheeler et al. 1990) and in *Apis mellifera* (Cruz-Höfling et al. 1970; Hoage and Kessel 1968; Lensky et al. 1979; Peng et al. 1992, 1993). In this last species, unlike the other Hymenoptera studied, the acrosome is almost as long as the nucleus, measuring about 5.6  $\mu\text{m}$ . The fact that the acrosome of *P. droryana* shows a circular cross section at the tip gradually being modified into a triangular form as it reaches towards the nucleus differs from other Hymenoptera where this acrosome are always circular (ex. Symphyta, Newman and Quicke 1999a; Cynipoidea, Newman and Quicke 1999b; Chalcidoidea, Lino-Neto et al. 1999, 2000a; Lino-Neto and Dolder 2001b; Formicidae, Wheeler 1990),

←

Figs. 1–14. Ultramicrographs of *Plebeia* spermatozoa in seminal vesicle. 1–2, Longitudinal and transverse sections, respectively, of anterior region of a spermatodesm. 1, Acrosomal region (arrow) and portion of nucleus (n) embedded in less electron dense extracellular material (\*). The arrowhead indicates the centriolar adjunct. 2, Numbers 1–6 indicate acrosomes sectioned in anterior-posterior levels from tip to just above nucleus. 3–4, Phase contrast micrograph of a spermatozoa (3) and head region, DAPI-stained fluorescence of nucleus. The arrow indicates the head (h) and tail (t) limit. 5, Longitudinal section showing acrosome (ac) and nucleus. 6, Longitudinal section of acrosomal vesicle (av) and perforatorium (p). 7, Transition region of acrosome-nucleus showing perforatorium base fitting into cavity of nuclear tip. 8–10, Transverse section of acrosome tip (8), base of acrosome (9) and nucleus free of extra cellular material (10). 11–13, Longitudinal sections of nucleus-flagellum transition region. Arrows indicate connective material at nuclear base (12, 13); 14, Longitudinal section at junction of centriolar adjunct and smaller mitochondrial derivative. Arrowhead indicates mitochondrial cristae. Abbreviations: n = nucleus; ac = acrosome; av = acrosomal vesicle; p = perforatorium; ca = centriolar adjunct; ax = axoneme; M = larger mitochondrial derivative; m = smaller mitochondrial derivative. Scale bar: 1, 4, 8–9 = 3 $\mu\text{m}$ ; 2 = 2 $\mu\text{m}$ ; 3 = 8 $\mu\text{m}$ ; 6 = 0,1 $\mu\text{m}$ ; 7 = 0,2 $\mu\text{m}$ ; 10–11, 14 = 0,3 $\mu\text{m}$  and 5, 12–13 = 0,5 $\mu\text{m}$ .

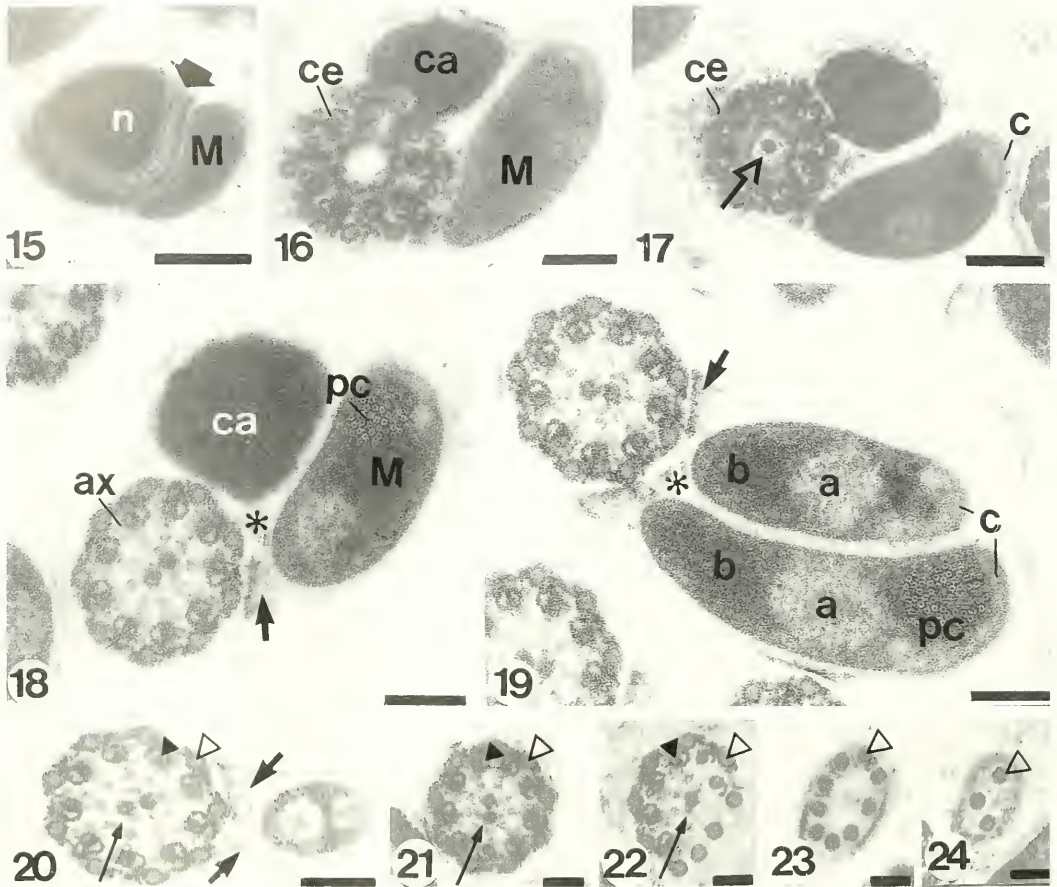

Figs. 15–24. Sequential transverse sections of flagella. 15, Nucleus-flagellum transition region. Arrow indicates material connecting nucleus to larger mitochondrial derivative. 16–17, Centriolar region of axoneme. Open arrow indicates first of central microtubules. 18–19, Sections of flagellum, at centriolar adjunct region and at both mitochondrial derivatives, respectively. The arrows indicate accessory bodies and (\*) indicates central material between flagellar structures. 20–24, Final flagellar region. The nine doublets (arrowheads) and two central microtubules (small arrow) terminate first, followed by accessory ones (white arrowheads). Large arrows indicate accessory bodies. Abbreviations: a = less electron dense amorphous region; b = more electron dense amorphous region; c = cristae region; pc = paracrystalline region in the larger mitochondrial derivative; ca = centriolar adjunct; ce = centriole; n = nucleus; ax = axoneme. Scale bar: 15–20 = 0,1 $\mu$ m; 21–22 = 0,06 $\mu$ m and 23–24 = 0,05 $\mu$ m.

or maintains an oval cross section as in *Apis mellifera* (q.v.) and Vespidae (personal observation). The acrosome of *A. mellifera* also differs from that of *P. droryana* due to the presence of a long anterior projection of the acrosomal vesicle (Cruz-Höfling et al. 1970; Hoage and Kessel 1968). The penetration of the perforatorium in the nuclear tip as occurs in *P. droryana* has been described for the majority of the hymenopterans (ex. Quicke et al. 1992; Newman

and Quicke 1999a; Wheeler et al. 1990). However, in Eurytomidae, *Beprhatelloides pomorum* Fabricius (Lino-Neto et al. 1999), and in the Pteromalidae, *Nasonia vitripennis* Walker (Hogge and King 1975), the perforatorium base is concave and has the same diameter as the nucleus in this region, fitting directly onto the anterior nuclear surface. In the majority of parasitic wasps, there is a third extracellular layer (the extracellular sheath), covering all of

the acrosome and extending along a variable length of the nucleus (Quicke et al. 1992; Newman and Quicke 1999b; Quicke et al. 1992; Newman and Quicke 1998; Quicke et al. 1992; Lino-Neto et al. 1999, 2000a; Lino-Neto and Dolder 2001b). Also, in some of these, the extra-cellular sheath gives rise to innumerable filaments, probably representing a well developed glyco-cocalix (Lino-Neto et al. 1999, 2000a; Lino-Neto and Dolder 2001b).

In *P. droryana*, the nucleus is long, dense and usually appears homogeneously compacted. These characteristics are highly conserved in Hymenoptera, and the variations observed have been in length and in the fact that this structure may be linear (ex. Quicke et al. 1992; Jamieson et al. 1999; Wheeler et al. 1990; Lino-Neto et al. 2000b), or twisted in a spiral, as in Chalcidoidea (Lee and Wilkes 1965; Hogge and King 1975; Quicke et al. 1992; Lino-Neto et al. 1999, 2000a, 2000b; Lino-Neto and Dolder 2001b), Scelionidae (Lino-Neto and Dolder 2001a) and Diapriidae (Quicke, personal communication). The nucleus of *P. droryana* ends in a short cone, next to the anterior tip of the large mitochondrial derivative, and terminating in contact with the centriolar adjunct and axoneme. In *Apis mellifera*, the final nuclear projection is considerably longer and inserted in the axoneme, so that in cross section the nucleus is found surrounding the tips of the centriolar microtubules (Peng et al. 1993; Lino-Neto et al. 2000b). In the majority of the Hymenoptera, the nucleus is not tapered posteriorly but instead is abruptly truncated (Quicke et al. 1992; Newman and Quicke 1999a; Newman and Quicke 1999b; Quicke et al. 1992; Wheeler et al. 1990; Lino-Neto et al. 1999, 2000a; Lino-Neto and Dolder 2001b).

The centriolar adjunct of *P. droryana* is a well developed structure located parallel to the axoneme and between the nucleus and the smaller mitochondrial derivative. This arrangement has also been found in some Symphyta (Newman and

Quicke 1999a), Cynipoidea (Newman and Quicke 1999b), Ichneumonoidea (Quicke et al. 1998) and in *A. mellifera* (Lino-Neto et al. 2000b). However, in the Ichneumonoidea this structure is comparatively short (Quicke et al. 1998) while in *A. mellifera*, it is extremely long, tapered anteriorly, widening into a thick rod posteriorly (Lino-Neto et al. 2000b). In the symphytan *Tremex* sp. (Newman and Quicke 1999a) and in the Formicidae (Wheeler et al. 1990), the centriolar adjunct lies between the nucleus and both mitochondrial derivatives. On the other hand, in Chalcidoidea (Lino-Neto et al. 1999, 2000a; Lino-Neto and Dolder 2001b) the centriolar adjunct is located laterally to the final portion of the nucleus, surrounding the nuclear-flagellum transition and extending parallel to the axoneme for a short distance, above the insertion of both mitochondrial derivatives. Contrary to the majority of these insects, no centriolar adjunct was encountered in Scelionidae (Lino-Neto and Dolder 2001a). The great variation in shape and location of the centriolar adjunct, differing from that known for most insects (Jamieson 1982) is probably the reason for the earlier misinterpretations of this element in various Hymenoptera (Cruz-Höfling et al. 1970; Quicke et al. 1992).

The mitochondrial derivatives of *P. droryana* are asymmetric not only in length but also in diameter. As a rule, the derivatives are straight (ex. Quicke et al. 1992; Jamieson et al. 1999; Wheeler et al. 1990; Lino-Neto et al. 2000b), but in Chalcidoidea (Lee and Wilkes 1965; Hogge and King 1975; Quicke et al. 1992; Quicke 1997; Lino-Neto et al. 1999, 2000a, 2000b; Lino-Neto and Dolder 2001b), Scelionidae (Lino-Neto and Dolder 2001a) and Diapriidae (Quicke, personal communication) they spiral around the axoneme. The larger mitochondrial derivative beginning next to the final projection of the nucleus was also observed in *A. mellifera* (Lino-Neto et al. 2000b) and in Cynipoidea

(Newman and Quicke 1999b). This is not the case of the majority of the Hymenoptera, where the larger mitochondrial derivative abuts the nuclear base, not overlapping it (ex. Quicke et al. 1992; Wheeler et al. 1990; Jamieson et al. 1999; Newman and Quicke 1999a). In Megalyroidea (Newman and Quicke 2000), Diapriidae (Quicke, personal communication) and Scelionidae (Lino-Neto and Dolder 2001a) the large mitochondrial derivative projects parallel to the nucleus for a considerable distance, and in this latter family, only one large mitochondrion is observed (Lino-Neto and Dolder 2001a). In transverse sections of the *P. doryana* flagellum, four distinct regions make up the larger derivative while only three are found in the smaller one. The same organization was observed in *A. mellifera* (Lino-Neto et al. 2000b) although Cruz-Höfling et al. (1970), Lensky et al. (1979) and Peng et al. (1992, 1993) have described the presence of paracrystalline material also in the smaller derivative. In the Formicidae the mitochondrial derivatives consist in three regions (Wheeler et al. 1990). However, the regions described in Formicidae are not analogous to those in the smaller derivative of *P. doryana*. In Formicidae, there is a clear area, a well developed region of cristae and the paracrystalline material situated in the mitochondrion's first third, proximal to the axoneme (Wheeler et al. 1990). Asymmetrical diameters of mitochondrial derivatives are frequently found, occurring in the Symphyta (Quicke et al. 1992; Newman and Quicke 1999a), Cynipoidea (Quicke et al. 1992; Newman and Quicke 1999b), Megalyroidea (Newman and Quicke 2000) and Proctotrupoidea (Quicke et al. 1992). However, bees are even more strongly asymmetrical (Cruz-Höfling et al. 1970; Hoage and Kessel 1968; Lensky et al. 1979; Peng et al. 1992, 1993; Lino-Neto et al. 2000b). On the other hand, some Hymenoptera have symmetrical mitochondrial derivatives as in Formicidae (Wheeler et al. 1990) and

Chalcidoidea (Lino-Neto et al. 1999, 2000a).

*Plebeia droryana*, as is common to most insects (Jamieson et al. 1999), has an axoneme with the microtubules arranged parallel to each other. This is not the case of Chalcidoidea (Lee and Wilkes 1965; Hodge and King 1975; Quicke et al. 1992; Quicke 1997; Lino-Neto et al. 1999, 2000a, 2000b; Lino-Neto and Dolder 2001b), Scelionidae (Lino-Neto and Dolder 2001a) and Diapriidae (Quicke, personal communication) where they follow a spiraling course. Also in *P. droryana*, the accessory microtubules are the last ones to terminate at the end of the axoneme. This characteristic is also observed in *A. mellifera* (Peng et al. 1993; Lino-Neto et al. 2000b) and in Formicidae (Wheeler et al. 1990), while in Chalcidoidea (Lino-Neto et al. 1999; Lino-Neto and Dolder 2000a, b) and Ichneumonoidea (Braconidae) (Newman and Quicke 1998) the accessory tubules terminate first. Unfortunately, this characteristic has not been taken in consideration by most studies of hymenopteran spermatozoa. We believe this could be a useful parameter to help separate the Aculeata, or parasitic wasps, from other Hymenoptera.

The triangularly shaped accessory bodies, as found in transverse sections of *P. droryana*, are encountered in most Hymenoptera (Quicke et al. 1992; Jamieson et al. 1999; Wheeler et al. 1990; Lino-Neto et al. 2000b). They may be considerably reduced in Chalcidoidea (Lino-Neto et al. 1999, 2000a; Lino-Neto and Dolder 2001b) and in the Scelionidae (Lino-Neto and Dolder 2001a) so that, in some cases, they are difficult to identify. The function of this structure has not been clearly established but they appear to be involved in the attachment of the mitochondrial derivatives on to the axoneme, since they do not occur between the centriolar adjunct and the axoneme.

In *P. droryana* a small central structure was identified between both the mitochondrial derivatives and the axoneme

(see asterisk in Figs. 18 and 19). This structure was initially described in Formicidae (Wheeler et al. 1990), but it is possible that it is present in the majority of Hymenoptera (Lino-Neto et al. 2000b).

Based on the characteristics compared above, the spermatozoa of this bee are, for the most part, similar to the majority of the Hymenoptera (Jamieson et al. 1999). Some distinct differences stand out. For example: (1) the arrangement of spermatozoa in spermatodesmata in the seminal vesicle, (2) the presence of a very long centriolar adjunct between the nucleus and the smaller mitochondrial derivative and (3) the presence of abundant paracrystalline material, exclusively in the large mitochondrial derivative.

The identification of these characteristics and other more subtle ones suggest that the sperm cell can furnish a character matrix for Hymenoptera that will be useful for future phylogenetic studies.

#### ACKNOWLEDGMENTS

The authors would like to thank Professor Dr. Lucio Antonio de Oliveira Campos (DBG/UFV) for supplying the insects. This research was supported by the Brazilian Agencies CNPq and FAPESP.

#### LITERATURE CITED

- Baccetti, B. 1972. Insect Sperm Cell. *Advanced Insect Physiology* 9: 315–397.
- Camargo, J. M. F. and S. R. M. Pedro. 1992a. Systematics, phylogeny and biogeography of the Meliponinae (Hymenoptera, Apidae) a mini review. *Apidologie* 23: 1–32.
- Camargo, J. M. F. and S. R. M. Pedro. 1992b. Sistemática de Meliponinae (Hymenoptera: Apidae): sobre a polaridade e significado de alguns caracteres morfológicos. In: C. Cruz-Landim and J. Chaud-Neto, *Anais do Encontro Brasileiro de Biologia de Abelhas e outros Insetos Sociais*. Ed. UNESP, São Paulo. Pp. 45–49.
- Cameron, S. A. 1991. A new tribal phylogeny of the Apidae inferred from mitochondrial DNA sequences. In: D. R. Smith (ed.), *Diversity in the genus Apis*. Westview Press, Boulder, Colorado, pp. 71–78.
- Cameron, S. A. 1993. Multiple origins of advanced eusociality in bees inferred from mitochondrial DNA sequences. *Proceedings of the National Academy Science of United States of America* 90: 8687–8691.
- Cameron, S. A., J. N. Derr, A. D. Austin, J. B. Woolley and R. A. Wharton. 1992. The application of nucleotides sequence data to phylogeny of the Hymenoptera: A review. *Journal of Hymenoptera Research* 1: 63–79.
- Carcupino, M., G. Profili, J. Kathirithamby, and M. Mazzini. 1995. Sperm ultrastructure of *Xenos vesparum* (Rossi) and its significance in the taxonomy and phylogeny of Strepsiptera (Insecta). *Mémoires du Muséum National d'Histoire Naturelle* 166: 291–296.
- Crosier, R. H. and P. Pamilo. 1996. *Evolution of Insect Colonies: Sex Allocation and King Selection*. Oxford University Press: 1–28.
- Cruz-Höfling, M. A., C. Cruz-Landim and E. W. Kitajima. 1970. The fine structure of spermatozoa from the honey bee. *Anais da Academia Brasileira de Ciências* 42: 69–78.
- Cruz-Landim, C. and D. Beig. 1980. An electron microscopic study of spermatogenesis in the drone of *Scaptotrigona postica* (Hymenoptera: Apidae). *International Journal of Invertebrate Reproduction* 2: 271–283.
- Cruz-Landim, C. and R. L. M. Silva de Moraes. 1980. Observations on the mitochondrial complex and head differentiation during spermiogenesis of the stingless bee *Melipona quadrifasciata anthidioides* Lep. *Cytobios* 27: 167–175.
- Cruz-Landim, C., D. Beig and R. L. M. Silva de Moraes. 1980. Process of differentiation during spermatogenesis in bees (Hymenoptera, Apidae). *Caryologia* 33 (1): 1–15.
- Dallai, R. 1979. An overview of atypical spermatozoa in insects. In: *The Spermatozoon*, (eds.) W. Fawcett and J.M. Bedford: 253–256. Urban and Schwarzenberg, Baltimore.
- Dallai, R. and B. A. Afzelius. 1990. Microtubular diversity in insect spermatozoa: results obtained with a new fixative. *Journal of Structural Biology* 103: 164–179.
- Dallai, R. and B. A. Afzelius. 1995. Phylogeny significance of axonemal ultrastructure: examples from Diptera and Trichoptera. *Mémoires du Muséum National d'Histoire Naturelle* 166: 301–310.
- Hoage, T. R. and R. G. Kessel. 1968. An electron microscope study of the process of differentiation during spermatogenesis in the drone honey bee (*Apis mellifera* L.) with special reference to centriole replication and elimination. *Journal of Ultrastructure Research* 24: 6–32.
- Hogge, M. A. F. and P. E. King. 1975. The ultrastructure of spermatogenesis in *Nasomia vitripennis* (Walker) (Hymenoptera: Pteromalidae). *Journal Submicroscopic Cytology* 7: 81–96.
- Jamieson, B. G. M. 1987. *The Ultrastructure and Phy-*

- logeny of Insect Spermatozoa. Cambridge University Press, Cambridge, 320 pp.
- Jamieson, B. G. M., R. Dallai and B. A. Afzelius. 1999. *Insects: Their Spermatozoa and Phylogeny*. Scientific Publishers, Enfield, New Hampshire, USA, 555 pp.
- Lee, P. E. and A. Wilkes. 1965. Polymorphic spermatozoa in the hymenopterous wasp *Dahlbomimus*. *Science* 147: 1445–1446
- Lensky, Y., E. Ben-David and H. Schindler. 1979. Ultrastructure of the spermatozoan of the mature drone honey bee. *Journal of Apiculture Research* 18: 264–271.
- Lino-Neto, J., S. N. Báo and H. Dolder. 1999. Structure and ultrastructure of the spermatozoa of *Bethylatelloides pomorum* (Fabricius) (Hymenoptera: Eurytomidae). *International Journal of Insect Morphology and Embryology* 28: 253–259.
- Lino-Neto, J., S. N. Báo and H. Dolder. 2000a. Structure and ultrastructure of the spermatozoa of *Trichogramma pretiosum* Riley and *Trichogramma atopovirilia* Oatman and Platner (Hymenoptera: Trichogrammatidae). *Acta Zoologica* (Stockholm) 81: 205–211.
- Lino-Neto, J., S. N. Báo and H. Dolder. 2000b. Sperm ultrastructure of the honey bee (*Apis mellifera*) (L) (Hymenoptera, Apidae) with emphasis on the nucleus-flagellum transition region. *Tissue and Cell*, 32: 322–327.
- Lino-Neto, J. and H. Dolder. 2001a. Ultrastructural characteristics of the spermatozoa of Scelionidae (Hymenoptera; Platygastroidea) with phylogenetic considerations. *Zoologica Scripta* 30 (2): 89–96.
- Lino-Neto, J. and H. Dolder. 2001b. Redescription of sperm structure and ultrastructure of *Trichogramma dendrolimi* (Hymenoptera: Chalcidoidea: Trichogrammatidae). *Acta Zoologica* 82 (2): 159–164.
- Newman, T. M. and D. L. J. Quicke. 1998. Sperm development in the imaginal testes of *Alciodes coxalis* (Hymenoptera: Braconidae: Rogadinae). *Journal of Hymenoptera Research* 7: 25–37.
- Newman, T. M. and D. L. J. Quicke. 1999a. Ultrastructure of imaginal spermatozoa of sawflies (Hymenoptera: Symphyta). *Journal of Hymenoptera Research*, 8: 35–47.
- Newman, T. M. and D. L. J. Quicke. 1999b. Ultrastructure of spermatozoa in *Leptopilina* (Hymenoptera: Cynipoidea: Eucolidae). *Journal of Hymenoptera Research* 8: 197–203.
- Peng, C. Y. S., C. M. Yin and L. R. S. Yin. 1992. Effect of rapid freezing and thawing on cellular integrity of honey bee sperm. *Physiological Entomology* 17: 269–276.
- Peng, C. Y. S., C. M. Yin and L. R. S. Yin. 1993. Ultrastructure of honey bee, *Apis mellifera* sperm with special emphasis on the acrosomal complex following high-pressure freezing fixation. *Physiological Entomology* 18: 93–101.
- Phillips, D. M. 1970. Insect sperm: structure and morphogenesis. *Journal of Cell Biology* 44: 243–277.
- Quicke, D. L. J. 1997. *Parasitic Wasps*. Chapman and Hall, London, 470 pp.
- Quicke, D. L. J., S. N. Ingram, H. S. Baillie and P. V. Gaitens. 1992. Sperm structure and ultrastructure in the Hymenoptera (Insecta). *Zoologica Scripta* 21: 381–402.
- Roig-Alsina, A. and C. D. Michener. 1993. Studies of the phylogeny and classification of long-tongued bees (Hymenoptera: Apoidea). *The University of Kansas Science Bulletin*, 55: 123–162.
- Ronquist, F., A. P. Rasnitsyn, A. Roy, K. Eriksson and M. Lindgren. 1999. Phylogeny of the Hymenoptera: A cladistic reanalysis of Rasnitsyn's (1988) data. *Zoologica Scripta* 28: 13–50.
- Rothschild, L. 1955. The spermatozoa of the honey bee. *Transactions of the Royal Entomological Society of London*. 107: 289–294.
- Woyke, J. 1984. Ultrastructure of single and multiple diploid honey bee spermatozoa. *Journal of Hymenoptera Research* 23: 123–135.
- Wheeler, D. E., E. D. Crichton and P. H. Krutzsch. 1990. Comparative ultrastructure of ant spermatozoa (Formicidae: Hymenoptera). *Journal of Morphology* 206: 343–350.
- Whitfield, J. B., S. A. Cameron. 1998. Hierarchical analysis of variation in the mitochondrial 16S rRNA gene among Hymenoptera. *Molecular Biology and Evolution* 15: 1728–1743.

## Seed-feeding Species of *Megastigmus* (Hymenoptera: Torymidae) Associated with Anacardiaceae

E. E. GRISELL AND G. L. PRINSLOO

(EEG) Systematic Entomology Laboratory, PSI, Agricultural Research Service, U. S. Department of Agriculture, c/o National Museum of Natural History, Washington, DC 20560-0168, USA;  
(GLP) Biosystematics Division, ARC-Plant Protection Research Institute, Private Bag X134, Pretoria 0001, South Africa

---

*Abstract.*—Four species of *Megastigmus* Dalman have been reported as phytophagous in seeds of the plant family Anacardiaceae: *M. pistaciae* Walker, *M. rhusi* (Hussey), *M. thomsoni* (Hussey), and *M. transvaalensis* (Hussey). All are Old World in origin. In this paper we summarize known host and distribution data for each species, place *Megastigmus rhusi* as a junior subjective synonym of *Megastigmus transvaalensis*, diagnose and illustrate all species, and provide a key to aid in the identification of females and, to some extent, males. Known host-plant genera are: *Pistacia* L., *Rhus* L., *Schinus* L., *Ozoroa* Delile, and *Lannea* A. Richard. *Megastigmus pistaciae* and *M. transvaalensis* have been accidentally introduced into the New World. The former has long been established in California and is reported for the first time from Mexico; the latter is widely established, through host-shifting, in the states of Hawaii, California, Florida, and in Brazil and Argentina.

---

The genus *Megastigmus* Dalman is represented by 126 described species known from all geographic areas (Grissell 1999, Grissell and Heydon 1999) except possibly South America, where the only reported species appears to have been introduced (Perioto 1999, Grissell and Hobbs 2000). Species are most abundant in the Holarctic and Australian Regions. About one-third of *Megastigmus* species are phytophagous in seeds of 11 plant families, about one-third are parasitoids (or inquilines) of gall-forming insects in the fruits, leaves, and stems of plants, and about one-third have no known hosts (Grissell 1999).

Our paper focuses on a group of *Megastigmus* species associated with the plant family Anacardiaceae. Although the family occurs worldwide, only four species of *Megastigmus* have been reported from its seeds, and these all appear to be indigenous to Africa, the Middle East, and the Mediterranean region. Introductions of two of these species have been reported for the New World: *M. pistaciae* Walker,

introduced into California (see species section below), and *M. transvaalensis* (Hussey), found in the states of Hawaii, California, Florida, and recently in Brazil and Argentina (see species section below).

Of the *Megastigmus* species attacking Anacardiaceae, three have been recognized based as much upon their host preference as upon their morphological distinctness: *Megastigmus pistaciae* reared from species of *Pistacia* L., *Megastigmus rhusi* (Hussey) reared from species of *Rhus* L., and *Megastigmus transvaalensis* reared from species of *Schinus* L., a South American tree introduced into Africa. The fourth species, *Megastigmus thomsoni* (Hussey), was reared from a questionable host (now confirmed as *Ozoroa* Delile, see discussion under *thomsoni*) and has been known only from the type series since its description. With only one published exception, whenever a species of *Megastigmus* has been identified from *Pistacia*, *Rhus*, or *Schinus*, the name given is always the one historically associated with the

host plant. The exception was published by Furth (1985:166) who reported *Megastigmus pistaciae* as the "... main pest of *R. [Rhus] tripartita* [(Ucria) DC] fruits" and considered it to be an "oliphagous [sic]" wasp based on the previous Old World host records from *Pistacia* spp. (Davatchi 1958, Romanenko 1972). Furth's specimens now reside in the National Museum of Natural History (Washington, DC) and, based on morphological criteria developed in our studies, they are not *M. pistaciae* but are *M. transvaalensis* as explained below.

In this paper we discuss all species of *Megastigmus* associated with seeds of Anacardiaceae, summarize all distribution and host data, and present a key. Our review is based on comprehensive new data for hosts and distributions based upon extensive surveys undertaken by both authors in South Africa. Additional Old World material was collected by Simon van Noort in Western Cape Province, South Africa, and Alain Roques in the Mediterranean Region). Extensive New World data have been provided by the sampling of Stephen Hight (USDA, Forest Service, Volcano, Hawaii), Greg Wheeler (USDA, Agricultural Research Service, Ft. Lauderdale, Florida), and their colleagues, as well as Richard Rice (University of California, Parlier, California). The material examined, in excess of 5000 specimens, is housed in the National Collection of Insects, PPRI, Pretoria; the South African Museum, Cape Town; and the National Museum of Natural History, Washington, D.C.

Special mention should be made concerning males of *Megastigmus* species associated with Anacardiaceae. In *M. pistaciae* and *M. transvaalensis* males are extremely variable in appearance (few males of *M. thomsoni* are known). Small individuals are yellow with no modifications of the stigma (Fig. 1) relative to females. Large males, however, have the head, lower mesosoma, and metasoma mostly

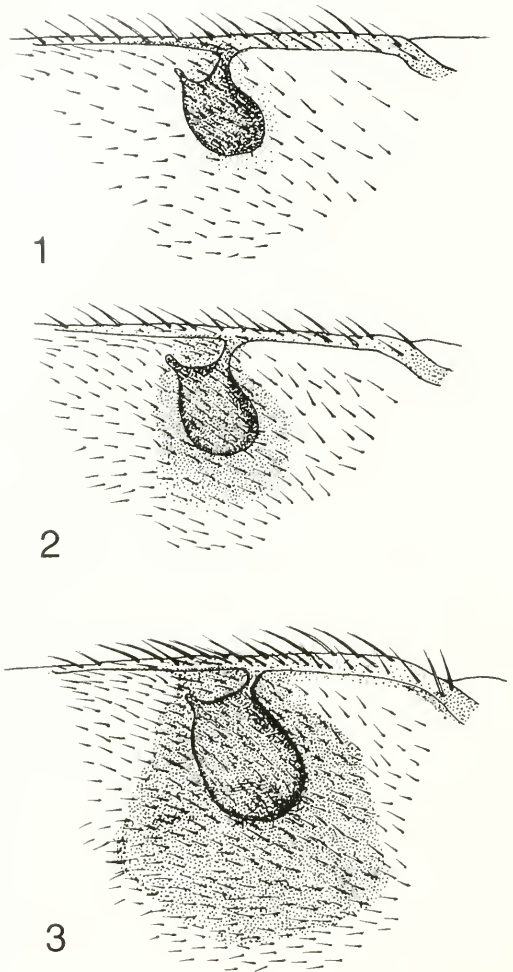

Figs. 1-3. *Megastigmus transvaalensis*, stigmatal area, male, showing variation. 1, Smallest specimens (all yellow). 2, Intermediate specimens (yellow with some black). 3, Largest specimens (black with some yellow).

black with yellow markings, the stigma is enlarged, and it is surrounded by a stigmatal cloud (Fig. 3). If the two extremes found within males of both *M. pistaciae* and *M. transvaalensis* (and presumably *thomsoni*) were distinct they might represent dimorphic male forms, however they are bridged by intermediate forms (Fig. 2). The condition does not seem to be polymorphic, as there is a gradual cline between extremes. Although some wing characters help distinguish females re-

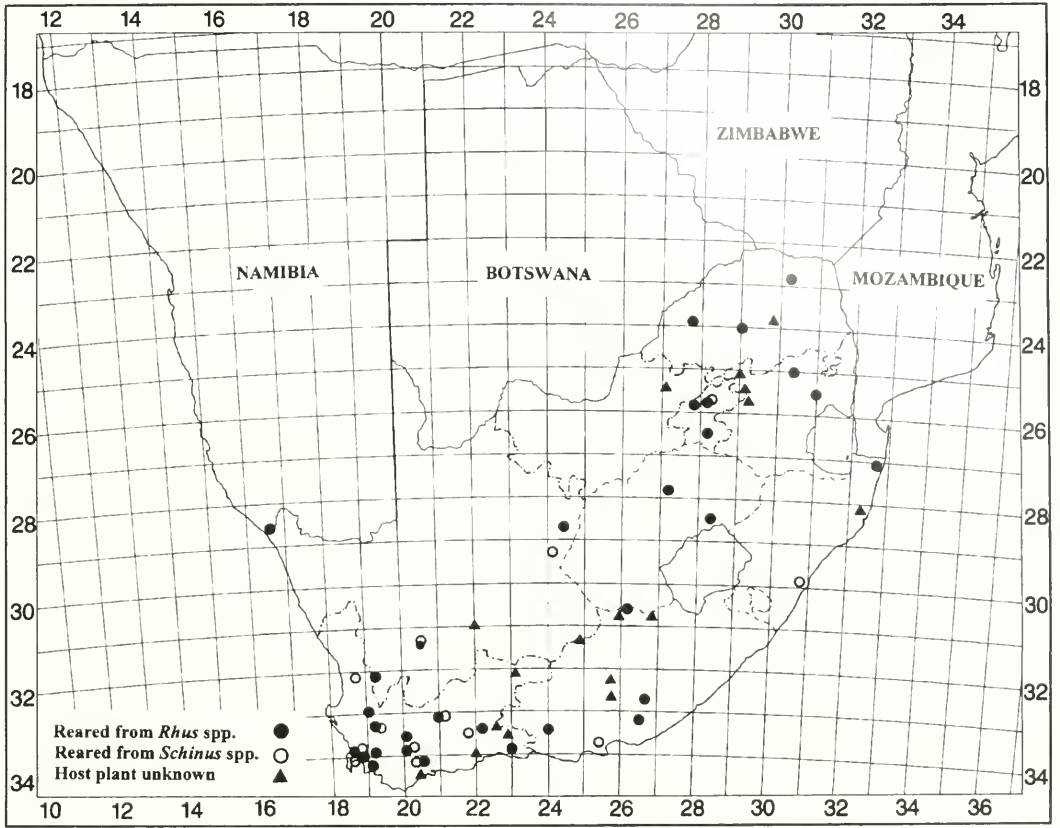

Fig. 4. Distribution of *Megastigmus transvaalensis* in South Africa. Symbols indicate plant host genus from which specimens were reared or collected.

ardless of size, they do not work for males. Small yellow males have slightly more setae on the wings than females, but larger black males are considerably more setose than even the small yellow males. In general, males of all species are relatively uncommon compared to females.

At first glance the large black males would seem to bear no relationship to their conspecific females. That they are conspecific is provided by three lines of evidence. Extremes of males may be found in rearings from the same host, locality, and time for both *M. transvaalensis* and *M. pistaciae*. In the field we have seen small yellow males of *M. transvaalensis* mating with females only to have larger black males chase them away and initiate mating themselves. In addition, DNA analysis

shows no differentiation within male phenotypes of *M. transvaalensis* and females (Scheffer and Grissell in preparation).

***Megastigmus transvaalensis* (Hussey)**  
(Figs. 1-3, 4-7)

*Eumegastigmus transvaalensis* Hussey 1956:161-162 (Figs. 1g,h, 4). Holotype female, Pretoria, Transvaal, South Africa (The Natural History Museum, London, examined); 5 female, 8 male paratypes, same data as holotype (The Natural History Museum, London; "Hussey private collection"), reared from seeds of *Schinus molle* L.

*Eumegastigmus rhusi* Hussey 1956:161 (Figs. 1e,f, 3). Holotype female, Bloemfontein, Orange Free State, South Africa (The Natural History Museum, London, examined); 2 female, 4 male paratypes, same data as holotype (The Natural History Museum, London; "Hussey

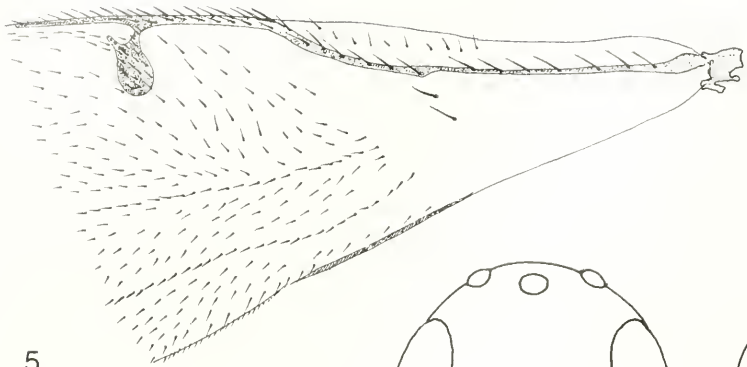

5

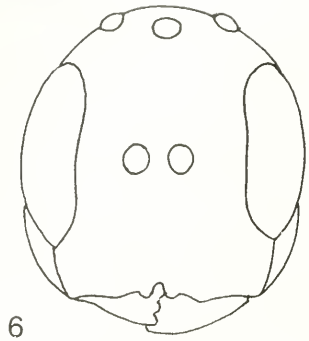

6

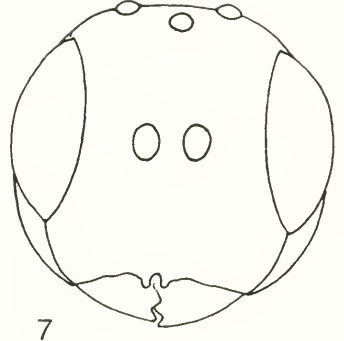

7

transvaalensis

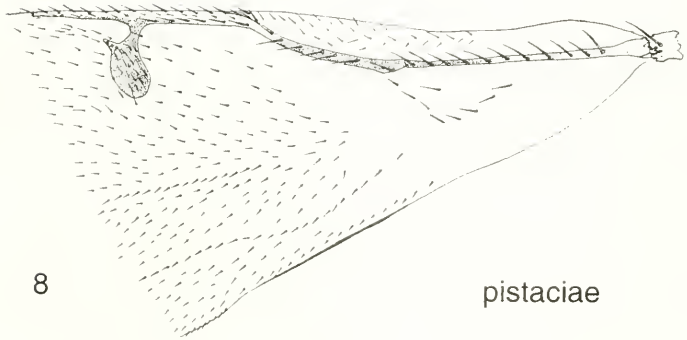

8

pistaciae

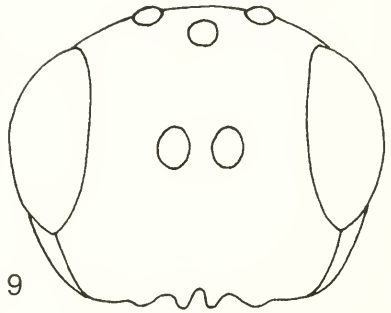

9

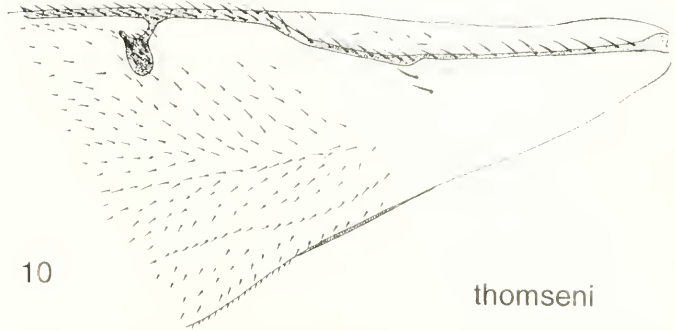

10

thomseni

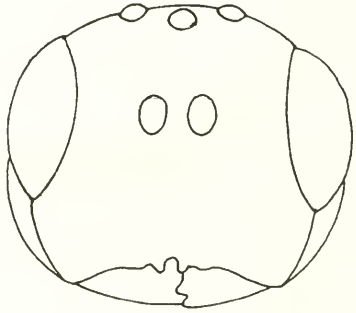

11

Figs. 5-11. *Megastigmus* species, female. 5, 8, 10, Forewing setation on dorsal surface, except costal cell shows ventral setae only. 6, 7, 9, 11, Heads, anterior view.

private collection"), reared from seeds of *Rhus lancea* L. *New synonymy*.

*Megastigmus transvaalensis*: Bouček 1978:129.

New combination from *Eumegastigmus*.

*Megastigmus rhusi*: Bouček 1978:129. New combination from *Eumegastigmus*.

*Diagnostic Characters*.—In both sexes of *M. transvaalensis* the face (Fig. 6, 7) is narrowed and at most as wide as high (to slightly higher than wide); the least interocular distance is greater than the scape length (excluding radicle); and the eye height is subequal to or greater than the least interocular distance. In some individuals the face is remarkably narrowed (Fig. 6) accompanied by a similar lateral compression of the body. In females (but not males) the costal cell ventrally has at most a longitudinal row of setae in its apical third to half (Fig. 5; these setae are sometimes broken off and the costal cell may appear aseptose); the upper surface of the costal cell is bare even at its apical margin; the basal cell has no setae either medially or along its posterior margin (i.e., the cubital setal line) (Fig. 5). The admarginal area of the forewing has setae extending as far (or nearly) as the stigmal vein (Fig. 5). Females range from about 2 to 3 mm in body length (without ovipositor).

*Distribution*.—In its natural range (based on association with *Rhus*), *M. transvaalensis* is common throughout South Africa (Fig. 4) and has also been found in single collections from Zimbabwe, Kenya, Israel, and Morocco.

Its putative areas of introduction (based on association with *Schinus*) include California (first reported by Harper and Lockwood 1961; reported also on introduced *Rhus lancea* by Grissell and Hobbs 2000), Florida (first report by Habeck *et al.* 1989), Hawaii (first report by Beardsley 1971 as *Megastigmus* sp.), Brazil (first report by Perioto 1999, as *Megastigmus* sp.), Argentina (S. Hight, pers. comm.), Réunion (Habeck *et al.* 1989), Canary Islands (Grissell 1979), and Mauritius (specimens in National Collection of Insects, PPRI, Preto-

ria). We have seen specimens from all these locations.

*Hosts*.—The hosts of *Megastigmus transvaalensis* are now known to include species of *Rhus* and *Schinus*, though the latter is a result of host shifting (Grissell and Hobbs 2000). Prior to our study, *M. transvaalensis* (as *M. rhusi*) was reported only from *Rhus lancea* (Hussey 1956). As a result of our studies, *M. transvaalensis* is now known to be reared from seeds of *R. augustifolia* L., *R. dentata* Thunb., *R. discolor* E. Mey. ex Sond., *R. laevigata laevigata* L., *R. laevigata villosa* (L.) R. Fernandes, *R. lucida* L., *R. magalismoutana* Sond., and *R. zeyheri* Sond. (all South African in distribution); *R. vulgaris* Meikle and *R. natalensis* Bernh. ex Kraus (Kenya); and *R. tripartita* (Ucria) DC (Morocco, Israel). Additionally, adult *M. transvaalensis* were collected on the following *Rhus* species, which may be host plants as well: *R. chirioidensis* Bak. (seeds were collected for rearing, but no wasps emerged), *R. crosa* Thunb., *R. pyroides* Burch., and *R. rehmanniana glabrata* R. & A. Fernandes and *R. pendulina* Jacq. growing together (seeds of the former were collected for rearing, but no wasps emerged; the latter was in bloom only).

*Megastigmus transvaalensis* has also been reared from seeds of *Schinus molle* and *S. terebinthifolius* Raddi, though these are non-native hosts.

*Discussion*.—In the past any specimen reared from *Schinus* seed was considered to be *M. transvaalensis* and any from *Rhus* seed was considered to be *M. rhusi*. A recent paper by Grissell and Hobbs (2000) presented the reasons for considering both to be conspecific and additional molecular analysis (Scheffer and Grissell, in preparation) has confirmed this to be the case. Neither paper presented formal nomenclatural decisions, and in the current paper we formally place *M. rhusi* as a junior subjective synonym of *M. transvaalensis*. We choose the name *transvaalensis* because

it is the only name that has appeared in the literature since its publication.

A single population was found in Kenya (collected by R. Copeland, specimens in USNM and Texas A & M University) in which all individuals ( $n = 90$ ) appear to be extremely laterally compressed and the head appears as in Figure 7 as compared to the typical head as in Figure 6. Within many other populations examined, similar appearing individuals were seen, but not the entire population. It is possible that the compressed condition is related to host seed morphology, or that a second species is present. So far, DNA studies of the two forms have proven inconclusive.

*Megastigmus transvaalensis* is believed to have been introduced into California along with its native host plant, *Rhus lancea*, and thereupon switched to introduced ornamental trees of the genus *Schinus* (Grissell and Hobbs 2000). Its presence in Hawaii, Florida, Brazil, and Argentina is presently under study by EEG and colleagues who are attempting to trace its pattern of geographic movement (Scheffer and Grissell, in preparation).

*Megastigmus pistaciae* Walker  
(Figs. 8, 9)

"*Megastigmus pistaciae* Haliday": Walker 1869: 313. [*Nomen nudum*]

*Megastigmus pistaciae* Walker 1871:35. Syntype females, "S. France" and "Tuscany" (The Natural History Museum, London, examined), taken on "*Pistacia lentiscus* [L.] and on *P. terebinthus* [L]."

*Trogocarpus ballestrevii* Rondani 1877:204–205 (Figs. 109–114). Lectotype female (designated by Bouček 1974:245), Italy (La Specola, Florence), reared from seeds of *Pistacia vera* L. [Synonymized by Masi 1934:210.]

**Diagnosis.**—In both sexes of *M. pistaciae* the face is transverse, being wider than high, and the least interocular width is less than the eye height (Fig. 9). In females (but not males) the costal cell has 3 or 4 ventral rows of short setae in its apical half or more (Fig. 8); the cubital setal line

has at least a few setae along the posterior margin of the basal cell (Fig. 8); and the admarginal area has setae reaching to the stigmal vein. This is the largest species of *Megastigmus* associated with Anacardiaceae, with females reaching 3.5 mm to 5 mm in body length (without ovipositor).

**Distribution.**—This species is endemic to the Old World, with a known distribution in coastal Mediterranean areas (Bouček 1977) from Italy and Greece where it extends into Iran (Roques and Skrzypczynska in preparation), the Crimea, Transcaucasia, and Turkmenia (Bouček 1977). It has been introduced into the United States where it occurs in California (Robinson 1968), and we have seen specimens from Saltillo, Coahuila, Mexico (ex *Pistacia* sp.), which represent the first records for that country. We have seen one specimen intercepted at an American port of entry from Australia (*Pistacia chinensis* Bunge) in 1970 (National Museum of Natural History, Washington, DC). If the data are authentic, this is the only report of the species from Australia.

**Hosts.**—*Megastigmus pistaciae* is confined to seeds of species of the genus *Pistacia*. The following hosts have been reported for the natural range of *M. pistaciae* (only first report of hosts are cited): *Pistacia vera* and *P. terebinthus* (De Stefani 1917), *P. mutica* Fisch. & C. A. Mey [now = *P. atlantica mutica* (Fisch. & C. A. Mey) Rech. F.] (Nikol'skaya 1935), and *P. atlantica* Desf. (Davatchi 1958). In its introduced range (California), *M. pistaciae* has been reported attacking the following species of *Pistacia*: *P. chinensis* Bunge, *P. integerrima* J. Stewart [now = *P. chinensis integerrima* (J. Stewart) Rech. F.], *P. atlantica*, *P. lentiscus*, *P. vera* 'Kerman' (commercial cultivar), and a hybrid between *P. atlantica* and *P. vera* (Rice and Michailides 1988).

Furth (1985) reported this species in association with rearings from *Rhus tripartita* (in Israel), but based on an examination of voucher specimens in the National Muse-

um of Natural History, Washington, DC, these specimens are *M. transvaalensis*.

**Biology.**—The biology of this species (as *ballestrerii*) was discussed by De Stefani (1908, 1917). In Italy, eggs were deposited in June and July. Larvae were mature by September and overwintered until May when they pupated and emerged. Generally there was only a single generation per year, but occasionally a few of the larvae pupated in August and September. At this time most of the host seeds were too hard for oviposition, but a few soft young fruits could be found and two generations per year occurred. Similar findings were made in Greece (Agnostopoulos 1938, as *ballestrerii*), Tunisia (Jarraya and Bernard 1971), and California (Rice and Michailides 1988). Zerova and Seryogina (1994) illustrated the damaged seed. Males of this species are reportedly uncommon, ranging only up to about 4% (Rice and Michailides 1988). Additional observations for this species in California are given by Vettel and Harper (1969), Wiard (1969), and Rice and Jones (1996).

**Parasitoids.**—Two eurytomids, *Sycophila biguttata* (Swederus) and *Eurytoma rosae* Nees, have been reported as parasites of *M. pistaciae* (Davatchi 1958) in its endemic range.

**Discussion.**—Walker (1869) created a *nomen nudum* when he published the name "*Megastigmus pistaciae* Haliday." Haliday neither used the name nor described the species. Walker (1871) eventually described the species. Bouček (1974) discussed the types of *ballestrerii* and the question of synonymy, which might be attributed either to Masi (1934) by implication or directly to Nikol'skaya (1935:83). Nikol'skaya (1935) redescribed and illustrated the female (as *pistaciae*) as did Zerova and Seryogina (1994) and Roques and Skrzypczynska (in preparation).

*Megastigmus thomseni* (Hussey)  
(Figs. 10, 11)

*Eumegastigmus thomseni* Hussey 1956:159–161  
(Figs. 1c,d). Holotype female, Wolhuitens-

skop (misspelling for Wolhuterskop), Transvaal, South Africa (The Natural History Museum, London, examined); 4 female, 2 male paratypes same data as holotype (The Natural History Museum, London; "Hussey private collection").

*Megastigmus thomseni*: Bouček 1978:129. New combination from *Eumegastigmus*.

**Diagnosis.**—In both sexes of *M. thomseni* the face is transverse, being wider than high, and the least interocular width (Fig. 11) is greater than the eye height. In females (but not males) the costal cell ventrally has at most a median row of setae in its apical third to half (Fig. 10; sometimes these setae are broken off and the costal cell appears asetose); the cubital setal line has no setae along the posterior margin of the basal cell (Fig. 10); and the area proximal (inner) to the stigma and the admarginal area are essentially asetose. Females of this species range from 3 to 4 mm in body length (excluding ovipositor).

**Distribution.**—Apart from the type locality, this species is also reported here from the following South African localities: Rustenburg and Broederstroom (North-West Province), Pretoria (Gauteng Province), Thabazimbi (Northern Province), Lake St. Lucia (Kwazulu-Natal Province), and Richtersveld (Northern Cape Province). It also has been collected from a single locality in Kenya (Coast Province, El Nino road to Mica Creek, May 13, 1999, R. Copeland).

**Hosts.**—The types were reared from seeds of "witharpuisbos", a common name that Hussey suggested might refer to *Heeria* sp. Based on our knowledge of indigenous species, the common name actually applies to *Ozoroa paniculosa* (Sond.) R. and A. Fernandes, from which *thomseni* has subsequently been reared. This should be considered the correct host. We also have seen specimens reared from *Ozoroa obovata* (Oliv.) R. & A. Fernandes, *O. paniculosa*, and *Lamuca discolor* (Sond.) Engl.

**Discussion.**—Bouček (1978:129) trans-

ferred this species to the genus *Megastigmus*. It has remained unknown since its description, and its host is herein positively identified for the first time.

#### KEY TO SPECIES OF *MEGASTIGMUS* ATTACKING SEEDS OF ANACARDIACEAE

- 1 Females and males: Face transverse, wider than high; eye height slightly to much less than least interocular distance (Figs. 9, 11) ..... 2
- Females and males: Face about as high as wide; eye height equal to, or greater than, least interocular distance (Figs. 6, 7) ..... *transvaalensis* (Hussey)
- 2 Female: Forewing with costal cell ventrally with at most a single row of setae in apical 1/2 midway between front edge and submarginal vein (Fig. 10); admarginal area asetose (Fig. 10); basal cell, basal vein, and cubital setal line at most with 3 or 4 setae; only last segment of club with ventral micropilose area. (Small yellow males same for basal cell and area; large black males not yet known for this species) ..... *thomsoni* (Hussey)
- Female: Forewing with costal cell ventrally with 3 or 4 rows of setae in apical 1/2 to 2/3 (Fig. 8); admarginal area with several setae extending as far (or nearly) as stigmal vein (Fig. 8); basal cell, basal vein, and cubital setal line with more than 5 setae; last 2 segments of club with ventral micropilose area. (Small yellow males as for female; large black male: costal cell ventrally densely setose, upper surface with setae in apical 1/3) ..... *pistaciae* Walker

#### Acknowledgments

During the course of this study we were given assistance in our field work and in museum research by the following individuals for whom we express our sincerest thanks: Simon van Noort, Vincent Whitehead, and Hamish Robertson, South African Museum, Cape Town; David McDonald and John Donaldson, National Botanic Institute, Kirstenbosch, Cape Town; Jan Giliomee and Henk Geertsema, University of Stellenbosch, Stellenbosch; Brian Barnes, ARC-Fruit, Vine and Wine Research Institute, Stellenbosch; Gail Littlejohn and Mark Wright, Agricultural Research Council, Elsenburg; John Marshall, De Muel Farm, Ceres; Percy Watkins, Green Valley Nuts, Prieska; John Heraty, University of California, Riverside, California; Chris Desjardins, University of Maryland, College Park, Maryland; Richard Rice, University of California (Davis Campus), Parlier, California; Nelson Periotto, Instituto Biológico, Ribeirão Preto, Brazil; Gregory Wheeler, USDA, ARS, Ft. Lauderdale, Florida; Stephen Hight, USDA, FS, Volcano, Hawaii; R. Copeland and R. Wharton, Texas A & M University, College Station, Texas, with the aid of a USAID-sponsored fruit sampling program, ICIPE, Kenya; Alain Roques, INRA-Zoologie Forestière, Olivet, France; and Sonja Scheffer, Systematic Entomology Laboratory (SEL), USDA, ARS, Beltsville, Maryland. We are also grateful to John Noyes for the loan of type material from the Natural History Museum, London, and to him, Thomas Henry (SEL), David Smith (SEL), and two anonymous reviewers for reading the manuscript and making many helpful suggestions.

#### Literature Cited

- Agnostopoulos, P. T. 1938. [Pests of hazel, chestnut and pistachio]. *Dendrokronologia Eurena* 3: 497–544. [In Greek.]
- Beardsley, J. W. 1971. Notes and Exhibits: *Megastigmus* sp. *Proceedings of the Entomological Society of Hawaii* 21: 28.
- Bouček, Z. 1974. On the Chalcidoidea described by C. Rondani. *Redia* 55: 241–285.
- Bouček, Z. 1977. A faunistic review of the Yugoslavian Chalcidoidea (Parasitic Hymenoptera). *Acta Entomologica Jugoslavica* 13 (Suppl.): 1–145.
- Bouček, Z. 1978. A study of the non-podagrionine Torymidae with enlarged hind femora, with a key to the African genera. *Journal of the Entomological Society of Southern Africa* 41: 91–134.
- Davatchi, G. A. 1958. Etude biologique de faune entomologique des *Pistacia* sauvages et cultivés. *Revue de Pathologie Végétale et d'Entomologie Agricole de France* 37:3–166.
- De Stefani, T. 1908. *L'Insetto dei frutti di pistacchio e modo di limitarne i danni*. Istituto di Zoologia e Anatomia Comparata della R. Università, Palermo. 61 pp.
- De Stefani, T. 1917. [*Megastigmus ballestrerii*, a hymenopteron living on pistacio tree and turpentine tree in Sicily.] *Bolletino Studi Inform. R. Giordano Coloniale di Palermo* 4: 101–131. [In Italian.]
- Furth, D. B. 1985. The natural history of a sumac tree, with an emphasis on the entomofauna. *Transactions of the Connecticut Academy of Arts and Sciences* 46:137–234.
- Grissell, E. E. 1979. Torymidae, pp. 748–769. In, K. V.

- Krombein, P. D. Hurd, D. R. Smith, and B. D. Burks editors, *Catalog of Hymenoptera in America North of Mexico. Vol. 1. Symphyta and Apocrita*, in Washington, D.C.: Smithsonian Institution Press. 1198 pp.
- Grissell, E. E. 1999. An annotated catalog of world Megastigminae (Hymenoptera: Chalcidoidea: Torymidae). *Contributions of the American Entomological Institute* 31(4): 1–92.
- Grissell, E. E. and S. Heydon. 1999. The identity of two unplaced New World Megastigminae (Hymenoptera: Torymidae). *Proceedings of the Entomological Society of Washington* 101: 611–613.
- Grissell, E. E. and K. R. Hobbs. 2000. *Megastigmus transvaalensis* (Hussey) (Hymenoptera: Torymidae) in California: Methods of introduction and evidence of host shifting, pp. 265–278. In, A. D. Austin and M. Dowton (Eds) *The Hymenoptera: Evolution, Biodiversity and Biological Control*. CSIRO Publishing, Melbourne, Australia.
- Habeck, D. H., F. D. Bennett, and E. E. Grissell. 1989. First record of a phytophagous seed chalcid from Brazilian peppertree in Florida. *Florida Entomologist* 72:378–379.
- Harper, R. W. and S. Lockwood. 1961. Bureau of Entomology. Forty-first Annual Report. *California Department of Agriculture Bulletin* 2:127–129.
- Hussey, N. W. 1956. A new genus of African Megastigminae (Hymenoptera: Chalcidoidea). *Proceedings of the Royal Entomological Society of London (B)* 25:157162.
- Jarraya, A., and J. Bernard. 1971. Premières observations bioécologiques sur *Megastigmus pistaciae* en Tunisie. *Annales de l'Institut National de la Recherche Agronomique le Tunisie* 44: 1–28.
- Masi, L. 1934. Nota sur Calcididi dell'Isola di Rodi. *Bollettino della Società Entomologica Italiana* 66: 210.
- Nikol'skaya, M. N. 1935. [*Pistacia* seed-eating chalcids and their parasites (Hymenoptera, Chalcididae)]. *Plant Protection, Leningrad* 1935: 81–87. [In Russian.]
- Perioto, N. W. 1999. [First record of the genus *Megastigmus* Dalman, 1820 (Hymenoptera: Torymidae) and first record for the subfamily Megastigminae from Brazil.] *Arquivos do Instituto Biológico São Paulo* 64 (1997): 115–116. [In Portuguese.]
- Rice, R. E. and R. Jones. 1996. Seasonal monitoring of the pistachio seed chalcid. *Kearney Plant Protection Group, Plant Protection Quarterly* 6(1):1–3.
- Rice, R. E. and T. J. Michailides. 1988. Pistachio seed chalcid, *Megastigmus pistaciae* Walker (Hymenoptera: Torymidae), in California. *Journal of Economic Entomology* 81:1446–1449.
- Robinson, D. W. 1968. *California Department of Agriculture pistachio seed chalcid progress report* 68–1. 2 pp.
- Romanenko, K. E. 1972. [The principal pests of fruit of pistachio (*Pistacia*) and the possibilities for their biological or chemical control in Kirgiza]. *Proceedings of the 13th International Congress of Entomology* 3:85 [In Russian.]
- Rondani, C. 1877. *Vesparia parasita non vel minus cognita. Bollettino della Società Entomologica Italiana* 9: 166–213.
- Roques, A. and M. Skrzypczynska. [In prep.] Seed-infesting chalcids of the genus *Megastigmus* Dalman (Hymenoptera: Torymidae) native and introduced to Europe: taxonomy, host specificity and distribution. *Journal of Natural History*.
- Vettel, W. G. and R. W. Harper. 1969. *California Department of Agriculture Pistachio Seed Chalcid Progress Report No. 69–1*.
- Walker, F. 1869. Notes on Chalcididae; and descriptions of a new species of *Megastigmus*. *Transactions of the Royal Entomological Society of London* 1869: 313–314.
- Walker, F. 1871. *Notes on Chalcididae. Part II.—Eurytomidae and Torymidae*, pp. 19–36. London: E. W. Newman.
- Wiard, W. W. 1969. Observations on the newly introduced pistachio seed chalcid, *Megastigmus pistaciae* Walker. *California Department of Agriculture Report January 1969*.
- Zerova, M. D., and L. Y. Seryogina. 1994. [*The seed-feeding Chalcidoidea of Palearctics*]. Kiev: National Academy of Sciences of Ukraine, L. L. Schmalhausen Institute of Zoology, Naukova Dumka. 237 pp. [In Russian.]

## NOTE

### *Polynema* Haliday, 1833 (Insecta, Hymenoptera): Designation of *Polynema flavipes* Walker, 1846, as the Type Species

JOHN T. HUBER AND Z. BOUČEK

(JTH) Canadian Forest Service, Natural Resources Canada, c/o ECORC, K. W. Neatby Building, C. E. F., Ottawa, ON, K1A 0C6, Canada; (ZB) c/o Department of Entomology, The Natural History Museum, Cromwell Road, London, SW7 5BD, England

---

*Abstract.*—*Polynema flavipes* Walker, 1846 (= *P. ovulorum* Haliday, 1833, misidentification of *Ichneumon ovulorum* Linnaeus) is designated as type species of *Polynema*, a widespread genus of Mymaridae.

---

For more than 50 years it has been known that the previously designated type species of the widespread genus *Polynema* (Mymaridae, Hymenoptera) needed to be fixed by the ICZN. This is done here, using the first of the five species originally included in *Polynema* by Haliday, namely *P. flavipes*, but initially misidentified by him as *P. ovulorum* Linnaeus, 1758.

The genus *Polynema* was briefly described by Haliday (1833: 269). In the second part of his paper (1833: 347–348) he included five species in his genus: *Ichneumon ovulorum* Linnaeus and four new ones. The former species was quoted later by Westwood (1839: 78) in his “examples of species of the British genera” as a “typical species” of the genus *Polynema*, an action that was later generally understood as a formal designation of the type species of genera, as ruled in ICZN Opinion 71 (1922).

Soon after his proposal of *Polynema*, Haliday himself discovered that the Linnean species *ovulorum* could not belong to *Polynema*, not even to Mymaridae, because he (Haliday) had misidentified the species. At that time, Haliday passed many of his chalcidological notes on to Francis Walker

who eventually published them, as proved by his statement (1846: 49) “The following descriptions are, excepting a few additions, extracted from MSS kindly given to me by Mr. Haliday.” It was therefore Walker (1846: 52) who gave a new name, *Polynema flavipes*, to the species that Haliday had earlier misidentified, and added the comment “*ovulorum* olim; nomen errore ortum” [earlier *ovulorum*, the name used by mistake]. Despite this, however, the error was repeated several times before 1960, lastly in the important work by Debauche (1948), who redescribed (pp. 212–213) the species in question as *Polynema ovulorum* (L.). Debauche (1949: 6, 7) and Soyka (1956: 2, 3) further discussed the problem but without a satisfactory resolution, and Soyka (1956: 76) redescribed what he thought was *Polynema ovulorum*, based on a specimen collected by him in Austria in 1944 that he incorrectly designated as lectotype and genotype.

Another slight confusion was due to Hincks (1950: 177) who also referred to the misidentification problem. Hincks stated that the genotype [of *Polynema*] is the same as *Eutriche gracilis* Nees, 1834 (= *ovulorum* Haliday nec Linnaeus). This was accepted by Mathot (1968: 276), who also

referred to the problem. Graham (1973) found and examined one original female specimen of *Eutriche gracilis* Nees, labelled it as the lectotype, and showed that it is a species of *Polynema* not identical with *P. flavipes* Walker (*ovulorum* sensu Haliday).

The type material of *Ichneumon ovulorum* could not be examined because it has been long lost, but the recent consensus is that it belonged to the present family Scelionidae (superfamily Platygastroidea) (Bouček 1981: 18; Graham 1982: 228–229; Johnson 1992: 605, and references therein).

The identity of *Polynema flavipes* Walker, a replacement name for "*ovulorum* sensu Haliday, 1833", was objectively defined by Hincks (1950: 181–183) who designated a lectotype (in the Haliday collection, Dublin) for the species. Graham (1982: 229) also examined the lectotype and confirmed that it belongs to the present valid genus *Polynema* Haliday. He suggested that the logical course would be to invalidate Westwood's designation of *Ichneumon ovulorum* Linnaeus as type species of *Polynema* and to designate *Polynema flavipes* Walker, 1846 (= *P. ovulorum* Haliday, 1833, misidentification of *Ichneumon ovulorum* Linnaeus) as type species of *Polynema*. We concur with Graham's suggestion. Hence, under ICZN (1999) Article 70.3.2 (4th edition, valid from 1st January, 2000), we herewith fix *Polynema flavipes* Walker, 1846, misidentified as *Polynema ovulorum* (Linnaeus, 1758) by Haliday, 1833, as type species of the genus *Polynema* Haliday, 1833.

#### LITERATURE CITED

Bouček, Z. 1981. A biological solution to the identity of a Linnean chalcid wasp (Hymenoptera). *Entomologist's Gazette* 32: 18–20.

- Debauche, H.R. 1948. Etude sur les Mymarommidae et les Mymaridae de la Belgique (Hymenoptera Chalcidoidea). *Mémoires du Musée Royal d'Histoire Naturelle de Belgique* 108: 1–248.
- Debauche, H.R. 1949. Exploration du Parc National Albert, Mission G.F. de Witte (1933–1935). 49: 1–105 + 13 plates.
- Graham, M.W.R. de V. 1973. The identity of *Eutriche gracilis* Nees (Hymenoptera: Mymaridae). *Entomologist's Gazette* 24: 362–364.
- Graham, M.W.R. de V. 1982. The Haliday collection of Mymaridae (Insecta, Hymenoptera, Chalcidoidea) with taxonomic notes on some material in other collections. *Proceedings of the Royal Irish Academy*, B 82: 189–243.
- Haliday, A.H. 1833. Essay on the classification of the parasitic Hymenoptera of Britain, which correspond with the *Ichneumones minuti* of Linnaeus. *Entomological Magazine* 1: 259–276, 333–350.
- Hincks, W.D. 1950. Notes on some British Mymaridae (Hym.). *Transactions of the Society for British Entomology* 10: 167–207.
- ICZN. 1999. *International Code of Zoological Nomenclature*. Fourth Edition. The International Trust for Zoological Nomenclature. c/o The Natural History Museum, London. 306 pp.
- ICZN Opinion 71 (1922) Interpretation of the expression "typical species" in Westwood's (1840) Synopsis. *Smithsonian Miscellaneous Collections* 73(1): 16–18.
- Johnson, N.F. 1992. Catalog of world species of Proctotrupeoidea, exclusive of Platygastriidae (Hymenoptera). *Memoirs of the American Entomological Institute* no. 51. 825 pp.
- Linnaeus, C. 1758. *Systema naturae per regna triad naturae, secundum classes, ordines, genera, species, cum characteribus differentiis, synonymis, locis. Tomus I.* Holmiae, Sweden. 824 pp.
- Soyka, W. 1956. Monographie der Polynemagruppe. *Abhandlungen der Zoologisch-Botanischen Gesellschaft in Wien* 29: 1–115.
- Mathot, G. 1968. Mymaridae nouveau d'Afrique central (Hymenoptera: Chalcidoidea). *Revue de Zoologie et de Botanique Africaines* 78: 265–276.
- Walker, F. 1846. Descriptions of the Mymaridae. *Annals and Magazine of Natural History* 18: 49–54.
- Westwood, J.O. [June] 1839. Pp. 78–79 in: *Synopsis of the genera of British insects*: 49–80 [Issued with An introduction to the modern classification of insects. London.]







## INSTRUCTIONS FOR AUTHORS

**General Policy.** The *Journal of Hymenoptera Research* invites papers of high scientific quality reporting comprehensive research on all aspects of Hymenoptera, including biology, behavior, ecology, systematics, taxonomy, genetics, and morphology. Taxonomic papers describing single species are unlikely to be accepted unless a strong case is evident, such as importance in economic entomology or with concurrent biology or ecology. Manuscript length generally should not exceed 50 typed pages; however, no upper limit on length has been set for papers of exceptional quality and importance, including taxonomic monographs at generic or higher level.

All papers will be reviewed by at least two referees. The referees will be chosen by the appropriate subject editor. However, it would be helpful if authors would submit the names of two persons who are competent to review the manuscript.

The language of publication is English. Summaries in other languages are acceptable.

**The deadline for receipt of manuscripts is 1 October (for the April issue) and 1 April (for the October issue).**

**Format and Preparation.** Three copies of each manuscript, including copies of illustrations, should be submitted on letter size or A4 paper, double spaced, with at least 25 mm margins on all sides. On the upper left of the title page give name, address and telephone and fax numbers of the author to whom all correspondence is to be sent.

The paper should have a concise and informative title, followed by the names and addresses of all authors. The sequence of material should be: title, author(s), abstract, text, acknowledgments, literature cited, appendix, figure legends, figure copies (each numbered and identified), tables (each numbered and with heading). Each of the following should start a new page: (1) title page, (2) abstract, (3) text, (4) literature cited, (5) figure legends, (6) footnotes.

Following acceptance of the manuscript, the author should provide the editor with one copy of the manuscript accompanied by a copy on diskette using DD, double sided computer diskettes—IBM compatible MS DOS 5.25 inch or IBM and Macintosh 3.5 inch diskettes. (Authors who do not have access to a computer should submit three copies of the manuscript.) The paper may be submitted in most PC and Mac word processor programs such as Microsoft Word, FullWrite Professional, WordPerfect, WriteNow, Nisus, MacWrite, or MacWrite II. If possible, all words that must be italicized should be done so, not underscored. Tables may be formatted in a spread sheet program such as MS Works or MS Excel. Text should be double-spaced typing, with 25 mm left and right margins. Tables should be put in a separate file. Diskettes should be accompanied by the name of the software program used (e.g., WordPerfect, Microsoft Word). Authors should keep backup copies of all material sent to the Editor. The Society cannot be responsible for diskettes or text mislaid or destroyed in transit or during editing.

Illustrations should be planned for reduction to the dimension of the printed page (14 × 20.5 cm, column width 6.7 cm) and allow room for legends at the top and bottom. Do not make plates larger than 14 × 18 in. (35.5 × 46 cm). Individual figures should be mounted on a suitable drawing board or similar heavy stock. Photographs should be trimmed, grouped together and abutted when mounted. Figure numbers should be on the plate, and it is strongly recommended that names be included after the numbers (e.g., Fig. 2, *texanus*). Include title, author(s) and address(es), and illustration numbers on back of each plate. Original figures need not be sent until requested by the editor, usually after the manuscript has been accepted. Reference to figures/tables in the text should be in the style "(Fig. 1)" "(Table 1)". Measurements should be in the metric system.

All papers must conform to the *International Code of Zoological Nomenclature*. The first mention of a plant or animal should include the full scientific name including the authority. Genus names should not be abbreviated at the beginning of a sentence. In taxonomic papers type specimens must be clearly designated, type depositories must be clearly indicated, and new taxa must be clearly differentiated from existing taxa by means of keys or differential diagnoses. Authors are required to deposit all type material in internationally recognized institutions (not private collections). Voucher specimens should be designated for specimens used in behavioral or autecological studies, and they should be deposited similarly.

Acceptance of taxonomic papers will not require use of cladistic methods; however, authors using them will be expected to specify the phylogenetic program used (if any), including discussion of program options used. A data matrix should be provided if the subject is complex. Cladograms must be hung with characters and these should include descriptors (not numbers alone) when feasible. The number of parsimonious cladograms generated should be stated and reasons given for the one adopted. Lengths and consistency indices should be provided. Adequate discussions should be given for characters, plesiomorphic conditions, and distributions of characters among outgroups when problematical.

References in the text should be (Smith 1999), without a comma, or Smith (1999). Two articles by a single author should be (Smith 1999a, 1999b) or Smith (1999a, 1999b). For multiple authors, use the word "and," not the symbol "&" (Smith and Jones 1999). For papers in press, use "in press," not the expected publication date. The Literature Cited section should include all papers referred to in the paper. Journal names should be spelled out completely and in italics.

**Charges.** Publication charges are \$10.00 per printed page. At least one author of the paper must be a member of the International Society of Hymenopterists. Reprints are charged to the author and must be ordered when returning the proofs; there are no free reprints. Author's corrections and changes in proof are also charged to the author. Color plates will be billed at full cost to the author.

All manuscripts and correspondence should be sent to:

Dr. E. Eric Grissell  
Systematic Entomology Laboratory, USDA  
c/o National Museum of Natural History  
10th and Constitution NW  
Washington, DC 20560-0168

Phone: (202) 382-1781 Fax: (202) 786-9422 E-mail: egrissel@sel.barc.usda.gov

CONTENTS  
(Continued from front cover)

SCHMIDT, S. and G. A. P. GIBSON. A new species of the genus <i>Orussonia</i> Riek and the female of <i>O. depressa</i> Riek (Hymenoptera: Symphyta, Orussidae) . . . . .	113
SHAW, S. R., G. SALERNO, S. COLAZZA, and E. PERI. First record of <i>Aridelus rufotaceus</i> Tobias (Hymenoptera: Braconidae, Euphorinae) parasitizing <i>Nezara viridula</i> nymphs (Heteroptera: Pentatomidae) with observations on its immature stages and development . . . . .	131
SOARES, L. A., L. R. S. ZANETTE, H. R. PIMENTA, A. GONÇALVES, and R. P. MARTINS. Nesting biology of <i>Isodontia costipennis</i> (Spinola) (Hymenoptera: Sphecidae) . . . . .	245
ZAMA, U., J. LINO-NETO, and H. DOLDER. Ultrastructure of spermatozoa in <i>Plebeia</i> ( <i>Plebeia</i> ) <i>droryana</i> Friese (Hymenoptera: Apidae: Meliponina) . . . . .	261
NOTE	
HUBER, J. T. and Z. BOUČEK. <i>Polynema</i> Haliday, 1833 (Insecta, Hymenoptera): designation of <i>Polynema flavipes</i> Walker, 1846, as the type species . . . . .	280

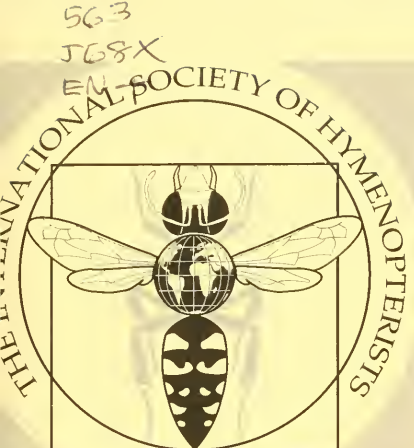

# Journal of Hymenoptera Research

**Volume 11, Number 1**

**April 2002**

ISSN #1070-9428

CONTENTS

EHLER, L. E., L. B. MALLER, and Y. HIROSE. Reproductive biology of <i>Gryou obesum</i> Masner (Hymenoptera: Scelionidae) .....	1
ENGEL, M. S. The fossil peleciniid <i>Pelecinopterion tubuliforme</i> Brues in Baltic amber (Hymenoptera: Peleciniidae) .....	5
FINNAMORE, A. T. Revision of the world genera of tribe Stigmini (Hymenoptera: Apoidea: Crabronidae: Pemphredoninae), Part 2. Species of <i>Iucastigmus</i> Finnamore ...	12
MANLEY, D. G. and J. P. PITTS. A key to genera and subgenera of Mutillidae (Hymenoptera) in America north of Mexico with description of a new genus .....	72
MATTHEWS, R. W. and I. D. NAUMANN. Descriptions and biology of nine new species of <i>Arpactophilus</i> (Hymenoptera: Crabronidae), with a key to described Australian species .....	101
SCHMIDT, S., D. R. SMITH, and J. MACDONALD. Review of the Australian subfamily Pteryperginae (Hymenoptera: Symphyta: Pergidae) .....	134
SMITH, D. R., A. D. WRIGHT, A. WINOTAI, and R. DESMIER DE CHENON. Studies on <i>Neostromboceros albicomus</i> (Konow) (Hymenoptera: Tenthredinidae), a potential biological control agent for the Old World climbing fern, with notes on two other species of <i>Neostromboceros</i> .....	142
WHITFIELD, J. B., A. BENZING, and F. PONCE. Review of the <i>Glyptapanteles</i> species (Hymenoptera: Braconidae, Microgastrinae) attacking noctuids in field crops in the Neotropical Region, with descriptions of two new species from the Ecuadorian Andes .....	152

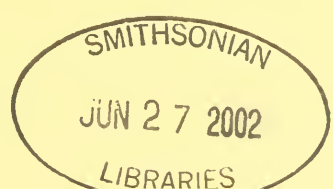

# INTERNATIONAL SOCIETY OF HYMENOPTERISTS

Organized 1982; Incorporated 1991

---

## OFFICERS FOR 2002

John LaSalle, *President*  
Lynn Kimsey, *President-Elect*  
James B. Woolley, *Secretary*  
John T. Huber, *Treasurer*  
E. Eric Grissell, *Editor*

---

## Subject Editors

SYMPHYTA AND PARASITICA  
*Biology:* Mark Shaw  
*Systematics:* Donald Quicke

ACULEATA  
*Biology:* Sydney Cameron  
*Systematics:* Wojciech Pulawski

---

All correspondence concerning Society business should be mailed to the appropriate officer at the following addresses: President, CSIRO Entomology, GPO Box 1700, Canberra, ACT 2601, Australia; Secretary, Department of Entomology, Texas A&M University, College Station, Texas 77843; Treasurer, Eastern Cereal & Oilseed Research Centre, Agriculture Canada, K. W. Neatby Building, Ottawa, Ontario, Canada K1A 0C6; Editor, Systematic Entomology Laboratory, USDA, % National Museum of Natural History, 10th and Constitution NW, Washington, D.C. 20560-0168.

**Membership.** Members shall be persons who have demonstrated interest in the science of entomology. Annual dues for members are US\$40.00 per year (US\$35.00 if paid before 1 February), payable to The International Society of Hymenopterists. Requests for membership should be sent to the Treasurer (address above). Information on membership and other details of the Society may be found on the World Wide Web at <http://IRIS.biosci.ohio-state.edu/ish>.

**Journal.** The *Journal of Hymenoptera Research* is published twice a year by the International Society of Hymenopterists, % Department of Entomology, Smithsonian Institution, Washington, D.C. 20560-0168, U.S.A. Members in good standing receive the *Journal*. Nonmember subscriptions are \$60.00 (U.S. currency) per year.

The Society does not exchange its publications for those of other societies.

**Please see inside back cover of this issue for information regarding preparation of manuscripts.**

---

## Statement of Ownership

Title of Publication: Journal of Hymenoptera Research.

Frequency of Issue: Twice a year.

Location of Office of Publication, Business Office of Publisher and Owner: International Society of Hymenopterists, % Department of Entomology, Smithsonian Institution, 10th and Constitution NW, Washington, D.C. 20560-0168, U.S.A.

Editor: E. Eric Grissell, Systematic Entomology Laboratory, USDA, % National Museum of Natural History, 10th and Constitution NW, Washington, D.C. 20560-0168, U.S.A.

Managing Editor and Known Bondholders or other Security Holders: none.

---

This issue was mailed 18 April 2002

## Reproductive Biology of *Gryon obesum* Masner (Hymenoptera: Scelionidae)

L. E. EHLER, L. B. MALLER, AND Y. HIROSE<sup>1</sup>

Department of Entomology, University of California, One Shields Avenue,  
Davis, California 95616-8584, USA

---

*Abstract.*—The reproductive biology of *Gryon obesum* Masner (Scelionidae) was investigated in the laboratory using eggs of *Euschistus conspersus* Uhler (Pentatomidae) as hosts. Females typically began ovipositing on the day of emergence and continued to oviposit for a mean of 40.7 days. Mean lifetime fecundity was 267 eggs/female. Mean daily fecundity was highest (~22 eggs/female) on the first day. By days 10 and 17, a mean of ~50% and ~75% of the eggs had been deposited, respectively. Sex ratio of progeny was female biased during the first part of the ovipositional period and male biased during the latter part. The post-ovipositional period was relatively short (mean of 5.6 days). Mean female longevity was 47.3 days when males and hosts were present, compared to 61.7 days for females that were deprived of males and host eggs. Because *G. obesum* has a shorter generation time and a greater lifetime fecundity than *E. conspersus*, it has great potential in augmentative biological control of this pest in crops such as processing tomato in northern California.

---

*Gryon obesum* Masner is a New World scelionid that parasitizes the eggs of stink bugs (Pentatomidae) (Johnson 1992). In the United States, it occurs primarily in southern areas, from Florida to California, where it is typically associated with hosts in the genera *Euschistus* and *Thyanta* (Masner 1983). In northern California, *G. obesum* is commonly reared from eggs of *E. conspersus* Uhler (conspersed stink bug) and *T. pallidovirens* (Stal) (red-shouldered stink bug) (Ehler 2000). However, its life history is poorly known. In view of this, we initiated laboratory investigations on *G. obesum*, with particular emphasis on reproductive biology and patch-use patterns. The present paper is restricted to reproductive biology, and its relevance to the use of *G. obesum* in augmentative biological control of *E. conspersus* on tomato in northern California.

### MATERIALS AND METHODS

Laboratory cultures of *E. conspersus* and *G. obesum* were established from field-collected material from the immediate vicinity of Davis, CA (Yolo County). Adults of *E. conspersus* were collected from weedy hosts, and from cultivated crops such as tomato and dried bean. Male/female pairs were placed in individual 450-ml ice cream containers, supplied with fresh green-bean pods (*Phaseolus vulgaris* L.) and raw sunflower seeds (*Helianthus annuus* L.), and held in a rearing room at 25°C and 16:8 (L:D) photoperiod. Containers were lined with paper towel which served as an ovipositional substrate. Containers were inspected daily; newly deposited eggs were cut out of the paper towel and fresh food was added as required. Egg masses were stored at 10°C for later use in assessing fecundity of *G. obesum* (usually <3 days). The culture of *G. obesum* was established from individuals reared from eggs of southern green stink

---

<sup>1</sup> Present address: 349 Asano, Munakata 811-3415, Japan (E-mail: yhirose@h7.dion.ne.jp)

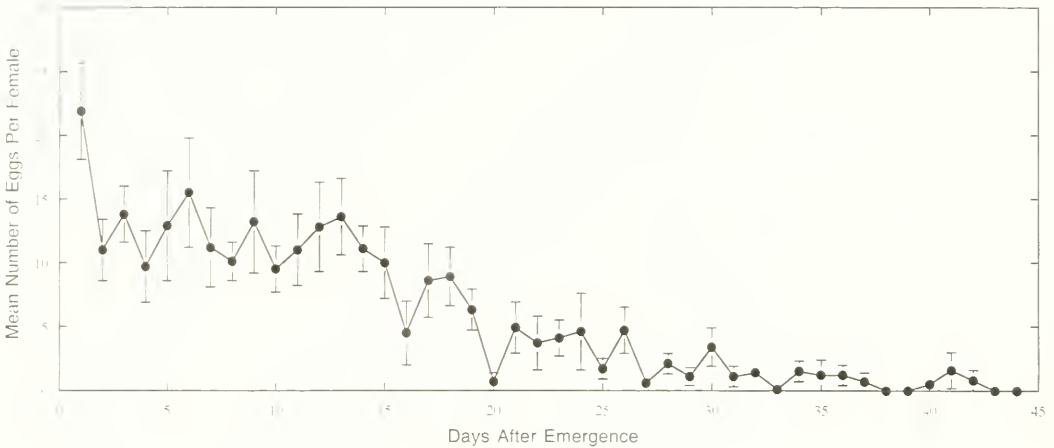

Fig. 1. Mean (SEM) daily fecundity of *G. obesum*.

bug, *Nezara viridula* (L.). This culture was maintained continuously on eggs of *E. conspersus* in a rearing room at 25°C and 10:14 (L:D) photoperiod.

Newly emerged male/female pairs ( $n = 10$ ) of *G. obesum* were confined to 450-ml ice cream containers. A plastic petri dish cover was placed over the top of the container; fresh honey was streaked across the inside of the lid. Dead males were replaced as needed with males of unknown age from the colony. Host egg masses were glued to a strip of paper that was inserted through an opening in the side of the container. Egg masses were changed at 24 h intervals. Individual females were initially exposed to 3–4 host egg masses (~40 eggs) per day; this was reduced to a single egg mass (~14 eggs) when daily fecundity declined to <10 eggs/female. Following exposure, egg masses were removed, placed in glass vials with cotton plugs, and held in the rearing room for parasitoid emergence. Daily oviposition rate was based on the total number of eggs parasitized, including those from which adults did not emerge. Sex ratio was determined for egg clutches in which all progeny (emerged and not emerged) could be accurately sexed. Voucher specimens of *G. obesum* are deposited in the

Bohart Museum of Entomology at the University of California, Davis.

## RESULTS AND DISCUSSION

The daily production of progeny by *G. obesum* is summarized in Fig. 1. Nine females oviposited on day one, and the remaining female commenced ovipositing on day two. Mean (SEM) daily fecundity was highest on day one ( $21.9 \pm 3.8$  eggs/female), ranged from  $9.5 \pm 1.8$  to  $15.5 \pm 4.3$  eggs/female from day two through day 15, and gradually declined thereafter. Mean (SEM) lifetime fecundity was  $267 \pm 17.3$  eggs/female. Of this total, ~25% were deposited by day 5, ~50% by day 10, and 75% by day 17. Mean (SEM) ovipositional and post-ovipositional periods were  $40.7 \pm 3.2$  and  $5.6 \pm 1.9$  days, respectively. Mean (SEM) longevity of females was  $47.3 \pm 1.9$  days ( $n = 7$ ) compared to  $61.7 \pm 6.4$  days ( $n = 9$ ) for females that were held under similar physical conditions but deprived of males and host eggs ( $t = 1.914$ ,  $df = 14$ ,  $P = 0.076$ ).

Sex ratio of progeny was directly related to the age of the female (Fig. 2). It was strongly female-biased during the early stage of the ovipositional period, but gradually shifted to male-biased by the end of the ovipositional period. In the latter case,

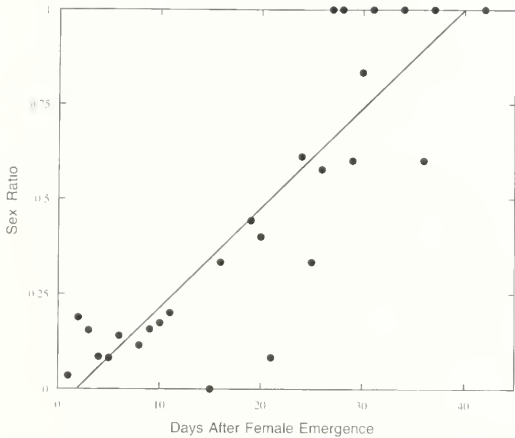

Fig. 2. Relationship between secondary sex ratio (proportion males) of progeny and age of female in *G. obesus*. Regression/correlation statistics as follows:  $Y = -0.05 + 0.026X$ ,  $r^2 = 0.75$ ,  $P = 0.0001$ . Only egg clutches in which all individuals could be accurately sexed are included; some points represent means of two or more clutches.

egg clutches were typically  $<5$  eggs/female. This shift in sex ratio may have resulted from sperm depletion. However, as it was necessary to use males of unknown age in some cases, this hypothesis cannot be adequately tested here.

Waage (1982) noted that maximum lifetime fecundity of scelionids probably ranges from 50–150 eggs/female. Thus, lifetime fecundity for *G. obesus* ( $>250$  eggs/female) would appear to be exceptionally high for a scelionid. It also is much greater than that of two Nearctic scelionids that commonly parasitize *E. conspersus* in northern California—i.e.,  $\sim 40$  to  $\sim 80$  eggs/female for *Telenomus podisi* Ashmead (Yeargan 1982, Orr and Boethel 1990) and  $\sim 65$  for *Trissolcus euschisti* (Ashmead) (Yeargan 1982). The same holds for *Gryon pennsylvanicum* (Ashmead), a Nearctic egg parasite of squash bug, *Anasa tristis* DeGeer—i.e.,  $\sim 80$  eggs/female (Nechols *et al.* 1989). Also, mean ovipositional period (40.7 days) and female longevity (47.3 days) for *G. obesus* are greater than for *T. podisi* ( $\sim 8$  and  $\sim 12$  days, respectively) (Yeargan

1982, Orr and Boethel 1990), *T. euschisti* ( $\sim 28$  and  $\sim 35$  days, respectively) (Yeargan 1982), and *G. pennsylvanicum* (22 and  $\sim 40$  days, respectively) (Nechols *et al.* 1989).

Based on reproductive biology of the three scelionid parasitoids of *E. conspersus* in northern California, *G. obesus* would be the clear choice for augmentative release against this pest in tomato. It has the highest lifetime fecundity, longest ovipositional period, and greatest female longevity of the three parasitoids, and thus could be expected to have the greatest impact on pest density. Also, *G. obesus* has a reproductive advantage over that of the pest. Lifetime fecundity of *E. conspersus* is  $\sim 225$  eggs/female at  $27^\circ\text{C}$  (Hunter and Leigh 1965, Toscano and Stern 1976), compared to  $>250$  for *G. obesus*. Also, generation time for *G. obesus* is much shorter—i.e.,  $\sim 15$  days (unpublished data) compared to  $\sim 50$  to  $\sim 55$  days for *E. conspersus* (Hunter and Leigh 1965, Toscano and Stern 1976). Thus *G. obesus* could complete at least three generations to each host generation. Finally, it could be expected to deposit  $\sim 50\%$  of its eggs in the first 10 days after emergence, further enhancing its impact in augmentative biological control.

#### ACKNOWLEDGMENTS

We thank M. J. Tauber and C. A. Tauber of Cornell University for critical review of the manuscript. This research was supported by Regional Research Project W-185.

#### LITERATURE CITED

- Ehler, L. E. 2000. *Farmscape Ecology of Stink Bugs in Northern California*. Memoirs, Thomas Say Publications in Entomology. Entomological Society of America, Lanham, MD. 59 pp.
- Hunter, R. E. and T. F. Leigh. 1965. A laboratory life history of the consperse stink bug, *Euschistus conspersus* (Hemiptera: Pentatomidae). *Annals of the Entomological Society of America* 58: 648–649.
- Johnson, N. F. 1992. Catalog of World Species of Proctotrupoidea, Exclusive of Platygasteridae (Hymenoptera). *Memoirs, American Entomological Institute*, No. 51. Gainesville, FL.

- Masner, L. 1983. A revision of *Gryon* Haliday in North America (Hymenoptera: Proctotrupoidea: Scelionidae). *The Canadian Entomologist* 115: 123–174.
- Nichols, J. R., J. L. Tracy and E. A. Vogt. 1989. Comparative ecological studies of indigenous egg parasitoids (Hymenoptera: Scelionidae; Encyrtidae) of the squash bug, *Anasa tristis* (Hemiptera: Coreidae). *Journal of the Kansas Entomological Society* 62: 177–188.
- Orr, D. B. and D. J. Boethel. 1990. Reproductive potential of *Telenomus cristatus* and *T. podisi* (Hymenoptera: Scelionidae), two egg parasitoids of pentatomids (Heteroptera). *Annals of the Entomological Society of America* 83: 902–905.
- Toscano, N. C. and V. M. Stern. 1976. Development and reproduction of *Euschistus conspersus* at different temperatures. *Annals of the Entomological Society of America* 69: 839–840.
- Waage, J. K. 1982. Sib-mating and sex ratio strategies in scelionid wasps. *Ecological Entomology* 7: 103–112.
- Yeargan, K. V. 1982. Reproductive capability and longevity of the parasitic wasps *Telenomus podisi* and *Trissolcus euschisti*. *Annals of the Entomological Society of America* 75: 181–183.

## The Fossil Pelecinid *Pelecinopteron tubuliforme* Brues in Baltic Amber (Hymenoptera: Pelecinidae)

MICHAEL S. ENGEL

Department of Ecology and Evolutionary Biology, and Division of Entomology, Natural History Museum and Biodiversity Research Center, Snow Hall, 1460 Jayhawk Boulevard, University of Kansas, Lawrence, Kansas 66045-7523, USA

---

*Abstract.*—The fossil pelecinid *Pelecinopteron tubuliforme* Brues (Proctotrupeoidea) is redescribed and figured based on a single, complete male preserved in middle Eocene (Lutetian) Baltic amber. Brues' original material is missing but comparison with his description and figures allows for positive identification of the species. Since the type material for this genus and species are untraceable and presumably destroyed the new specimen is herein designated as a neotype for the purpose of stabilizing the nomenclature and identity of this, the only definitive fossil of the family Pelecinidae.

---

The family Pelecinidae comprises the giants of the superfamily Proctotrupeoidea with slow-flying individuals ranging in size from 25 to 60 mm in total length. The family is today represented by only three extant species, all restricted to the Western Hemisphere—*Pelecinus polyturator* (Drury) is known from southeastern Canada, the eastern United States and Mexico, and south to northern Argentina; *P. dichrous* Perty in southeastern Brazil, Paraguay, Uruguay, and northern Argentina; and *P. thoracicus* Klug presently known only from western Mexico. Little is known of *Pelecinus* biology aside from some melonlonthine host records for *P. polyturator*. Individuals of *P. polyturator* have been reared from larvae of several *Phyllophaga* species (Coleoptera: Scarabaeidae) (see summary in Johnson and Musetti 1999). The three species were described and a key presented for their identification by Johnson and Musetti (1999).

Johnson (1998) recently reviewed the two fossil species for the family: *Pelecinopteron tubuliforme* Brues (1933) in Baltic amber and *Isocopinus baissicus* Kozlov (1974) preserved as a compression fossil from the

Lower Cretaceous of the Transbaikalian region. Based on considerable differences in wing venation and uncertain affinity to *Pelecinus* or other proctotrupoids, Johnson (1998) rightfully removed *Isocopinus* from the Pelecinidae s.str. and considered it as a family of indeterminate position within the Proctotrupeoidea. This action left the Eocene genus *Pelecinopteron* as the sole fossil representative for the Pelecinidae. Unfortunately, the two males and single female upon which Brues (1933) based his original description were from the ill-fated collections of the Albertus Universität in Königsberg (today Kaliningrad, Russia). During World War II this collection was destroyed by fire. Some portion of the collection was spared and today resides in the Institut und Museum für Geologie und Paläontologie, Göttingen. A personal investigation of this collection was made in July of 1999 but no material of *Pelecinopteron* could be discovered (other European institutions with amber collections were visited at the same time and additional Königsberg material was not located).

Herein I provide a new description and

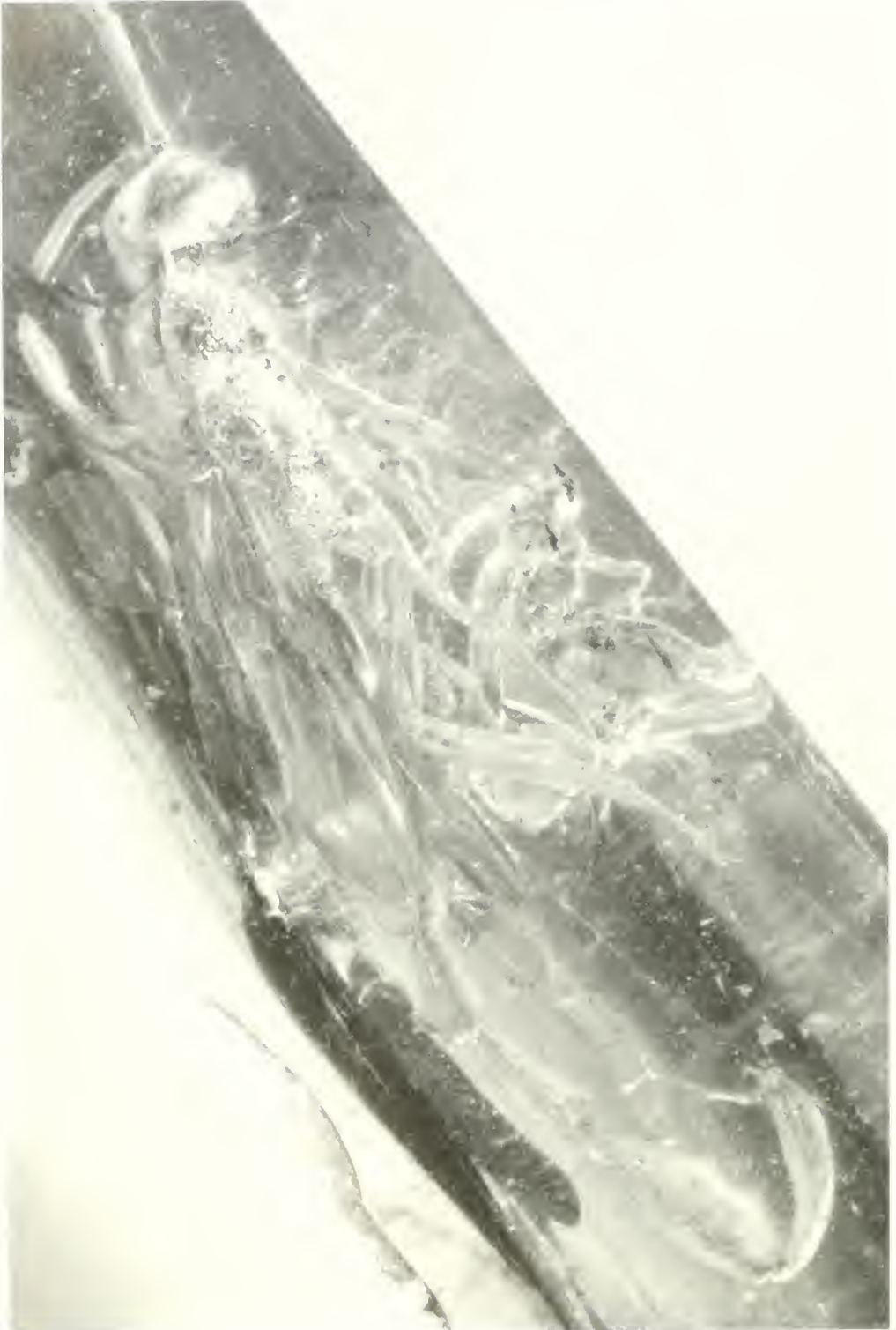

Fig. 1. Photomicrograph of *Pelecinopteron tubuliforme* Brues (AMNH).

figures for a complete male of *P. tubuliforme* recently identified in middle Eocene Baltic amber and designate this specimen as a neotype for the species. Format for the description generally follows that employed by Johnson and Musetti (1999) for living peleciniids so as to aid comparison with *Pelecinius*. Measurements were made using an ocular micrometer on an Olympus SZX12 stereomicroscope and should be considered somewhat approximate since the optimal angle for some metrics was not always achievable. Microphotographs were prepared using a Microptics ML-1000 digital imaging system. The age and origin of Baltic amber has been recently reviewed in Engel (2001).

## SYSTEMATIC PALEONTOLOGY

### Genus *Pelecinopter* Brues

*Pelecinopter* Brues 1933: 19. Type species: *Pelecinopter tubuliforme* Brues 1933, monobasic and original designation.

*Diagnosis*.—**Male**. Inner margins of compound eyes very slightly convergent below, essentially parallel; maxillary palpus 5-segmented; labial palpus 3-segmented [I could not discern a fourth, short, basal segment alluded to by Brues (1933)]; mandible bidentate, teeth short and equal in length, outer surface without dense, elongate setae; mandibles broadly overlapping. Clypeus convex, with coarse, faint punctures scattered over surface (distinctly not strongly punctured), without elongate setae, apical margin relatively straight. Ocelli positioned in equilateral triangle near top of vertex, median ocellus at upper tangent of compound eyes. Occipital carina strong, distinctly present both medially and laterally. Antenna filiform, 13-segmented; positioned slightly below midpoint of face, separated from base of clypeus by ca.  $1.75\times$  antennal socket diameter; combined lengths of scape and pedicel much shorter than first flagellomere, flagellomeres elongate, basal four flagellomeres with length ca.  $4.5-$

$6.5\times$  width, following four segments with length ca.  $4\times$  width, distal three segments with length ca. thrice width. Pronotum annular, dorsally with posterior section trap-ezoidal, this section anteriorly bordered by strong, transverse carina; anterior to carina pronotum gently sloping down to short anterior collar. Notauli formed of posteriorly converging, strong, crenulate impressions, confluent posteriorly; mesoscutum and scutellum separated by narrow suture, suture bordered by row of large, strong foveae on scutellum; axillae narrow; scutellum weakly arched; metanotum short. Mesepisternum with transverse furrow extending from faint episternal groove posteriorly, not reaching mes-metepisternal suture. Propodeum elongate; strongly and coarsely sculptured; sparsely setose. Tibial spur formula 1-2-2; metatibia gently expanded apically, metabasitarsus distinctly elongate, longer than three immediately following tarsal segments (i.e., length of tarsal segment 1  $\approx$  combined lengths of tarsal segments 2, 3, and 4); second tarsomere one-half length of metabasitarsus; fourth tarsomere extremely short, with inner apical margin projecting underneath fifth tarsal segment. Forewing with only two tubular veins (C and Sc+R); pterostigma elongate, tapering to point on anterior wing margin; R not extending beyond pterostigma; first abscissa of Rs slightly angled toward wing base, subequal in length to basal vein (i.e., first free abscissa of M); r-rs arising slightly basad pterostigmal midpoint (distad pterostigmal midpoint in *Pelecinius*); Rs forking slightly basad pterostigmal apex and distad forewing midpoint, forming two branches, Rs1 and Rs2, each branch equally pigmented and reaching to wing apex; Rs1 arching anteriorly before extending to wing apex; medial cell elongate; Cu reaching wing apex, slightly more heavily pigmented near wing margin than distalmost abscissae of Rs1, Rs2, and M; 2cu-a slightly distad 1m-cu; veins more strongly pigmented in basal two-thirds of wing (i.e.,

from slightly beyond pterostigmal apex to base of wing) except around second abscissa of Rs+M and anal vein with associated crossveins (i.e., 1cu-a and 2cu-a) very faintly indicated; membrane hyaline; venational details presented in figure 4. Hind wing without venation except C along anterior margin; without closed cells; membrane hyaline. Metasoma elongate; sixth metasomal segment swollen and enlarged, with strong teeth along longitudinal midline of sternum, first tooth at midpoint of sternal length, second tooth near apical fourth; sixth tergum and sixth sternum partially fused (i.e., suture between them exceedingly faint), same for

seventh metasomal segment; seventh metasomal segment generally falcate; parameres elongate. **Female.** Surviving specimens unknown; based on descriptive details in Brues' (1933) original description the female is generally as described for the male herein except for sexual differences. This will require confirmation when new material of the female sex is discovered.

*Comments.*—Brues (1933) originally proposed a separate family, Pelecinopteridae, for this genus while noting its strong affinity to Pelecinidae. Owing to the enormous similarity of *Pelecinopteron* with *Pelecinus* I agree with most authors (e.g., Johnson 1998) that the two genera should be placed in a single family.

---

#### KEY TO GENERA OF PELLICINIDAE

1. Antenna 14-segmented; malar space well-developed; r-rs arising in distal half of pterostigma; forewing with infuscation (particularly in costal cell, along anterior margin, and at apex); metabasitarsus distinctly shorter than following tarsomere; male metasoma clavate; body size large, ca. 25–60 mm (extant; Western Hemisphere) . . . . . *Pelecinus* Latreille
  - Antenna 13-segmented; malar space extremely short; r-rs arising in basal half of pterostigma; forewing apparently without infuscation; metabasitarsus distinctly longer than following tarsomere; male metasoma elongate; body size moderate, ca. 10–15 mm (early Cenozoic amber; Europe, northern Asia) . . . . . *Pelecinopteron* Brues
- 

#### *Pelecinopteron tubuliforme* Brues

(Figs. 1–4)

*Pelecinopteron tubuliforme* Brues 1933: 20. Kozlov 1974: 145 (translated version 1974: 137) [partial Paleocene amber specimen]. Johnson 1998: 2 [descriptive notes].

*Diagnosis.*—As for the genus (see above).

*Description.*—As described for the genus with the following additions: **Male.** Total body length (excluding antennae) 10.9 mm; forewing length 4.3 mm; head length 1.5 mm (head width indeterminate owing to angle from which front of face can be seen through amber surface); malar space length 0.07 mm; length of compound eye 1.1 mm; metasomal length 8.4 mm; length of first metasomal segment 1.0 mm; length

of second metasomal segment 1.0 mm; length of third metasomal segment 1.0 mm; length of fourth metasomal segment 0.8 mm; length of fifth metasomal segment 1.3 mm; length of sixth metasomal segment 1.9 mm; length of seventh metasomal segment 1.4 mm. Coloration of integument not well preserved, where evident apparently dark brown to black throughout.

Clypeus with sparse, faint, rather small, coarse punctures, integument otherwise smooth; remainder of head with minute, scattered punctures, integument between smooth. Dorsal-facing surface of pronotum with posterior portion separated from collar by transverse carina, integument of dorsal surface with minute punctures separated by a puncture width, integument



2

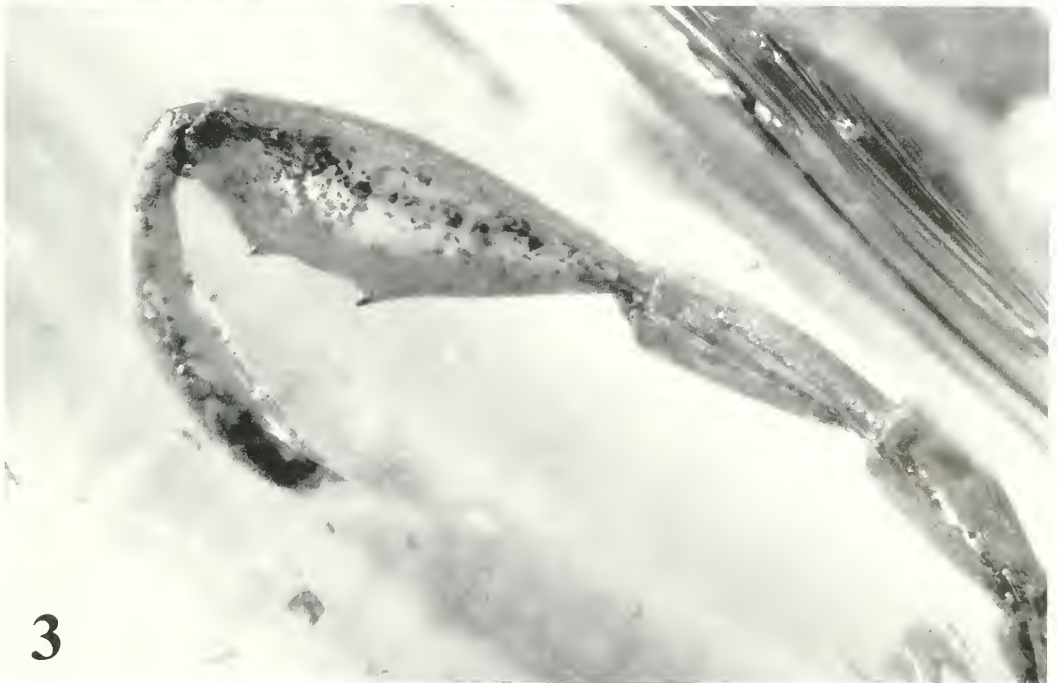

3

Figs. 2-3. Photomicrographs of *Pelecinopteron tubuliforme* Brues (AMNH). 2. Lateral view of mesosoma and head. 3. Lateral view of distal metasomal segments (from left to right = segments 7, 6, 5, 4, and apex of 3).

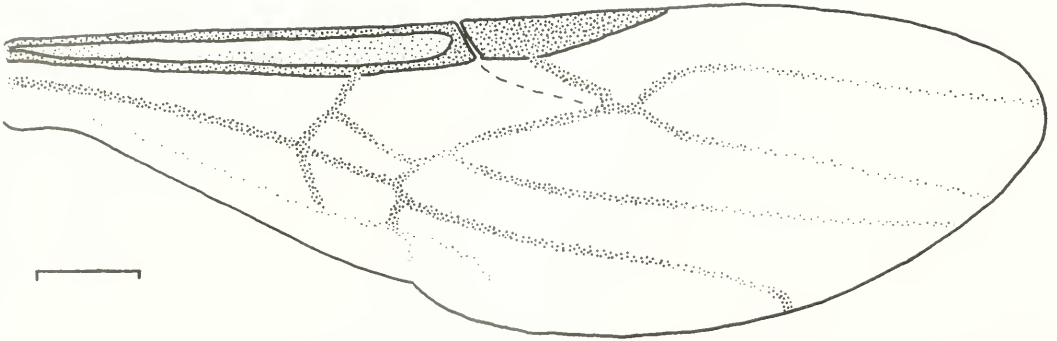

Fig. 4. Forewing venation of *Pelecinopteron tubuliforme* Brues (AMNH). Scale bar = 0.5 mm. Dashed line indicates an alar fenestra.

between smooth or slightly imbricate; lateral surface of pronotum with dorsal third smooth except along border with mesoscutum with minute punctures separated by a puncture width or slightly more, integument below smooth patch pronotum with large and strong punctures, punctures nearly confluent, integument between punctures (where evident) smooth. Mesoscutum with crenulations along lateral and anterior borders; notauli strongly impressed and crenulate, fusing posteriorly; integument in crenulations smooth, otherwise integument with minute punctures separated by a puncture width or slightly more; tegula with minute punctures separated by a puncture width, integument between punctures smooth; scutellum with strong and deep foveae along margins to form a small, medial, horizontal surface, integument in foveae smooth, on medial surface with minute punctures separated by a puncture width or slightly more, integument between punctures smooth. Mesepisternum with large and strong punctures, punctures nearly confluent, integument between punctures smooth; with transverse depression anteriorly connecting to short and more faint episternal groove (posteriorly this groove does not reach to the suture between the mes- and metepisternum), integument inside of groove smooth, above groove integument with minute punctures separat-

ed by a puncture width or less, integument between punctures smooth. Metepisternum sculptured as on mesepisternum below transverse groove. Propodeum sculptured as on mesepisternum below transverse groove except posteriorly punctures fusing to form large areolae. Metasoma with minute punctures widely scattered, integument otherwise smooth. Setae generally minute (less than a single ocellar diameter in length) and sparse except on legs, metasoma, and borders of pronotum and mesoscutum slightly more extensive but distinctly not dense. **Female.** Surviving specimens unknown; from the few descriptive notes provided by Brues (1933) females are generally as described for the male (above) aside from the typical sexual differences and perhaps some slight variations in sculpturing of the mesosoma.

*Material.*—**Neotype (here designated).** Male, Baltic amber, middle Eocene (Lutetian); labeled "Neotype, *Pelecinopteron tubuliforme* Brues, desig. M. S. Engel [red label]"; deposited in the Amber Collection of the Division of Invertebrate Zoology, American Museum of Natural History, New York. This specimen is designated in accordance with Article 75.3 (ICZN 1999) and for the express purpose of clarifying and stabilizing the taxonomic status of *P. tubuliforme*. The new specimen originates from the same deposits as the original series (i.e., the middle Eocene "Blue Earth"

deposits of northern Europe, from which Baltic amber originates: see Engel 2001). Although the holotype was originally a female, two males were also described and the current specimen corresponds in all observable details to those features described for the male by Brues (1933). Thus, in accordance with Article 75.3.5 the neotype may be based on a different sex (in this instance, a male).

*Comments.*—As mentioned above, the original material upon which Brues (1933) based his description is missing (and perhaps destroyed with the bulk of the Königsberg collection during World War II). A partial specimen consisting of only a male metasoma is known in Paleocene amber from Sakhalin, Russia (Kozlov 1974, Johnson 1998). No other specimens are presently recorded for this taxon. Thus, the specimen described herein is the only complete, surviving individual for the species and the only one originating from the same deposits as the original type series. When a more complete specimen of the species from Paleocene amber of Russia is discovered it may prove to be a separate species from *P. tubuliforme*. For example, the photograph published by Johnson (1998) does not clearly show the ventral teeth on the swollen sixth metasomal segment. Other differences may come to light with more completely preserved material.

## ACKNOWLEDGMENTS

I am grateful to Hans Jahnke for providing rooms in the Institut und Museum für Geologie und Paläontologie, for hosting my visit to Göttingen in 1999, and for general information on the amber collection; to David A. Grimaldi for bringing this specimen to my attention; to Tam C. Nguyen with help accessing literature; and to Allan H. Smith-Pardo, E. Eric Grissell, and two anonymous reviewers for commenting on the manuscript. This is contribution Nr. 3282 of the Division of Entomology, Natural History Museum and Biodiversity Research Center, University of Kansas.

## LITERATURE CITED

- Brues, C. T. 1933. The parasitic Hymenoptera of the Baltic amber: Part 1. *Bernstein-Forschungen* 3: 4–178.
- Engel, M. S. 2001. A monograph of the Baltic amber bees and evolution of the Apoidea (Hymenoptera). *Bulletin of the American Museum of Natural History* 259: 1–192.
- International Commission on Zoological Nomenclature. 1999. *International Code of Zoological Nomenclature* [4<sup>th</sup> Edition]. International Trust for Zoological Nomenclature; London, United Kingdom; xxix+306 pp.
- Johnson, N. F. 1998. The fossil peleciniids *Pelecinopteron* Brues and *Iscopinus* Kozlov (Hymenoptera: Proctotrupoidea: Peleciniidae). *Proceedings of the Entomological Society of Washington* 100(1): 1–6.
- Johnson, N. F., and L. Musetti. 1999. Revision of the proctotrupoid genus *Pelecinus* Latreille (Hymenoptera: Peleciniidae). *Journal of Natural History* 33: 1513–1543.
- Kozlov, M. A. 1974. [An early Cretaceous ichneumon of the family Peleciniidae (Hymenoptera, Pelecinoidea)]. *Paleontologicheskii Zhurnal* 1974(1): 144–146. [In Russian; English translation in *Paleontological Journal* 8(1): 136–138]

## Revision of the World Genera of Tribe Stigmini (Hymenoptera: Apoidea: Crabronidae: Pemphredoninae), Part 2. Species of *Incastigmus* Finnamore

ALBERT T. FINNAMORE

Invertebrate Zoology, Provincial Museum of Alberta, 12845–102 Avenue,  
Edmonton, Alberta, Canada T5N 0M6, E-mail: Albert.Finnamore@gov.ab.ca

---

*Abstract.*—*Incastigmus* is a Neotropical genus previously known from 2 species. In this paper 21 species of *Incastigmus* are described as new: *aylaxiter* (Argentina, Bolivia, Brazil), *caelukhus* (Peru), *cearaensis* (Brazil), *ceromus* (Peru), *chuncha* (Ecuador, Venezuela), *ictericornis* (Argentina, Paraguay, Bolivia, Brazil, Peru, Ecuador), *ignithorax* (Costa Rica, Panama), *iphis* (Brazil, Paraguay, Bolivia, Peru), *kunkopteryx* (Brazil, Bolivia, Peru, Ecuador, Colombia), *mauracis* (Brazil, Bolivia, Peru, Ecuador), *mystaxalbus* (Mexico, Guatemala, Honduras, El Salvador, Costa Rica), *mytior* (Brazil, Bolivia, Ecuador, Colombia, Venezuela), *paranicus* (Argentina, Bolivia, Brazil), *prophorodontis* (Brazil, Bolivia, Ecuador, Colombia, Panama, Venezuela, Trinidad and Tobago), *pynoglypticus* (Brazil), *pyrrhopyxis* (Peru, Ecuador, Colombia, Costa Rica, Trinidad and Tobago), *strepsilineatus* (Venezuela), *sunicerus* (Brazil), *trichodocerus* (Brazil, Paraguay, Peru, Ecuador, Colombia, Venezuela, Suriname, Trinidad and Tobago), *urqicus* (Brazil) and *zephyrus* (Mexico, Guatemala, Nicaragua, Costa Rica, Panama). *Stigmus hexagonalis* Fox (Colombia, Ecuador, Peru, Brazil) and *S. neotropicus* Kohl (Texas to Argentina) **new combinations**, are transferred to *Incastigmus*. Additionally, a key is provided to all species.

---

The genus *Incastigmus*, with 25 currently recognized species, was described to define a lineage of Neotropical Stigmini based on a phylogenetic analysis of the world taxa (Finnamore 1995). Its specimens are the most common Neotropical Stigmini in museum collections. The genus ranges from southern Texas to Argentina, but is not known north of the Lesser Antilles in the Caribbean, or from Chile. Nothing is known of the biology and behaviour of *Incastigmus*, but it is likely that all species construct nests in twigs and provision with aphids, as do most species in related genera. Several species in related genera nest in pre-existing cavities and some morphological and anecdotal evidence suggests *Parastigmus* species may be sand-nesting (Finnamore 1995). The title of the present paper reflects recent changes to the classification of apoid wasp lineages which, among other things, placed

the Pemphredoninae in the family Crabronidae (Melo 1999).

### METHODS

Terminology generally follows Bohart and Menke (1976), but in some cases needs clarification. Morphological terms are listed below:

*Appressed setae*: setae forming an angle close to 0° with the body surface.

*Lateral Sphere of propodeum*: convex area of propodeum between propodeal enclosure and side (Gittins 1969).

*LOD*: maximum diameter of lateral ocellus.

*Mesosoma*: the thorax plus the propodeum.

*Metasoma*: the apparent abdomen consisting of the abdomen excluding the first segment or propodeum.

*Micropore field*: a grouping of minute pores usually visible only with scanning

electron microscope, but by stereomicroscope with diffusing filter apparent as a discrete microsculpture patch or line on upper frons, usually between the lateral ocellus and the eye.

*Microsculpture*: minute sculpture imparting a dull appearance to the body.

*OOD*: ocellocular distance, the least distance between lateral ocellus and eye.

*Preomalar area*: area of mesopleuron anterior to ocellus (= preomalar area of Bohart and Menke (1976)).

*Transverse groove*: on pronotal dorsum, the transverse groove immediately posterior to the transverse carina.

Descriptions of all included species are provided based on the material examined. In species demonstrating variability, descriptions are based on representatives of the most prevalent phenotype with variation noted throughout the description. Collection data for the holotypes are presented as they appear on the label; thus several spellings for the same locality and collectors, and several formats for date of collection may be encountered. Collection data for paratypes are presented in a standard format of descending political units. Square brackets [ ] are used to indicate misspelling of localities, inability to confirm placement of a locality within a political unit, or when two or more localities with identical spelling exist within a political unit and the label data was insufficient to indicate which was intended (e.g., PERU: Ucayali: [San Pedro]—any of 4 localities named San Pedro within Ucayali Department, 47 localities within Peru). For previously described species only the collection localities and museums are listed.

The 2,043 specimens examined during this study were obtained from the following 31 institutions (the abbreviation preceding the institution is that used in the text to designate repositories):

AEIC—American Entomological Institute, Gainesville, Florida, U.S.A. (D. Wahl).

ANIC—Australian National Insect Col-

lection, CSIRO, Canberra, A.C.T., Australia. (I.D. Naumann).

BMNH—The Natural History Museum, London, United Kingdom. (C. Taylor, C.R. Vardy).

BPBM—Bernice P. Bishop Museum, Honolulu, Hawaii, U.S.A. (G.M. Nishida).

CASC—California Academy of Sciences, Golden Gate Park, San Francisco, California, U.S.A. (W.J. Pulawski).

CMNH—Carnegie Museum of Natural History, Pittsburg, Pennsylvania, U.S.A. (J.E. Rawlings).

CNCI—Canadian National Collection, Agriculture and Agri-Food Canada, Ottawa, Ontario, Canada. (J. Huber, L. Masner).

CSUC—Department of Entomology, Colorado State University, Fort Collins, Colorado, U.S.A. (H.E. Evans).

FSAG—Collections Zoologiques, Faculté des Sciences Agronomiques, Gembloux, Belgium. (J. Leclercq).

FSCA—Florida State Collection of Arthropods, Gainesville, Florida, U.S.A. (L. Stange, J. Wiley).

HNHM—Zoological Department, Hungarian Natural History Museum, Budapest, Hungary. (J. Papp).

IIES—Instituto de Investigaciones Entomológicas Salta "INESALT", Salta, Argentina. (M.A. Fritz).

IMLA—Fundación E Instituto Miguel Lillo, Universidad Nacional de Tucumán, Tucumán, Argentina. (A. Willink).

IZAV—Instituto de Zoología Agrícola, Universidad Central de Venezuela, Maracay, Aragua, Venezuela. (J. Luis García).

LACM—Los Angeles County Museum of Natural History, Los Angeles, California, USA. (R. Snelling).

MACN—Museo Argentino de Ciencias Naturales, Buenos Aires, Argentina. (A. Roig Alsina).

MCZC—Museum of Comparative Zoology, Harvard University, Cambridge, Massachusetts, U.S.A. (C. Vogt).

MJMO—Decanato de Agronomía, Univ-

ersidad Centro Occidental, Barquisimeto, Lara, Venezuela. (E. Yustiz).

MPEG—Museu Paraense Emilio Goeldi, Belem, Para, Brazil. (W.L. Overal).

MTEC—Entomology Collection, Montana State University, Bozeman, Montana, U.S.A. (M. Ivie).

MUCR—Museo de Insectos, Universidad de Costa Rica, Ciudad Universitaria, Costa Rica. (P. Hanson).

NHMW—Naturhistorisches Museum Wien, Wien, Austria. (M. Fischer).

OSUO—Department of Entomology Collection, Oregon State University, Corvallis, Oregon, U.S.A. (G.R. Ferguson).

PMAE—Provincial Museum of Alberta, Edmonton, Alberta, Canada.

RMNH—Nationaal Natuurhistorische Museum, Leiden, The Netherlands. (C. van Achterberg).

SEMC—Snow Entomological Museum, University of Kansas, Lawrence, Kansas, U.S.A. (R.W. Brooks).

SDMC—San Diego Natural History Museum, San Diego, California, U.S.A. (D.K. Faulkner).

SMTD—Staatliches Museum für Tierkunde, Dresden, Germany.

USNM—Smithsonian Institution, Washington D.C., U.S.A. (K.V. Krombein, A.S. Menke).

ZMAN—Instituut voor Taxonomische Zoologie, Universiteit van Amsterdam, Amsterdam, Netherlands. (W. Hogenes).

ZMUM—Zoological Museum, University of Moscow, Moscow, Russian Federation. (A.V. Antropov).

### *INCASTIGMUS* Finnamore

*Incastigmus* Finnamore 1995:234. Type species: *Incastigmus inti* Finnamore 1995:235, by original designation.

*Recognition.*—Specimens of *Incastigmus* can usually be recognized by the presence on the scutum of a median groove or posteromedian pit, a unique structure within western hemisphere Stigmini. The groove or pit must not be confused with the me-

dian, or posteromedian ridge or multiple ridges in some species of Neotropical *Stigmus*. The following combination will provide assurance of generic assignment for all known species: hind wing media diverging before cu-a; acetabular carina present; mandibles tridentate in both sexes with apicoventral tooth acute in female; and scutum with a median groove or posteromedian pit.

Since publication of Part 1 of this work (Finnamore 1995) I have found several males of *Llaqhastigmus mantanti* Finnamore which can be confused with those *Incastigmus* in which the scutal groove is reduced. Male *mantanti* sometimes have a series of short, evanescent, longitudinal striae along the posterior scutal margin in which the median pair mimic the posteromedian pit of some *Incastigmus*. The large bilobed labrum (lobes broad and separated by a slight emargination) in *mantanti* indicates it is a *Llaqhastigmus*, whereas *Incastigmus* possess a relatively small quadrilobed labrum (median lobes narrow and separated by a deep median notch). Male *mantanti* have been included in the following key to species of *Incastigmus* in order to avoid spreading mandibles to expose the labrum for generic determination. Female *mantanti* possess a large bilobed labrum and a slightly enlarged, blunt, apicoventral mandibular tooth, both diagnostic characters for *Llaqhastigmus*, and should not be confused with *Incastigmus* (apicoventral mandibular tooth acute) in the key to genera of Stigmini (Finnamore 1995). In addition, female *mantanti* lack any trace of a posteromedian scutal pit and the lateral clypeal teeth meet or exceed the median clypeal teeth in length. In *Incastigmus* the lateral clypeal teeth are smaller than the median teeth.

*Description.*—HEAD: Labrum 4-lobed, with narrow deep median emargination; mandibular apex of both sexes tridentate; apicoventral mandibular tooth in female acute; inner basal mandibular tooth absent; clypeal apex in male without bev-

elled modifications, in female with 4 teeth; interantennal tubercle and frontal line absent; micropore field present between lateral ocellus and eye; eye inner margins converging below; eyes at most partially margined by a carina; occipital carina present, complete, not joining hypostomal carina, simple in female, raised, foveolate in male. MESOSOMA: Scutum with median groove or at least posteromedian pit; notauli often elongate, reaching posterior scutal margin; acetabular carina present;

omaulus continuous with acetabular carina; scrobal sulcus present; hypoepimeral area without coarse sculpture; mid basitarsus of male elongate, as long as next 3 tarsomeres combined; posterior margin of hind tibia with 2 or 3 spines; fore wing aetose in cellular area; hind wing media diverging before cu-a; hind wing submedian cell of normal size, not reduced. METASOMA: Petiole carinate; pygidial plate narrow, absent in male; digitus longer than cuspis, clubbed.

KEY TO SPECIES OF *INCASTIGMUS*

1	Male: antenna with 11 flagellomeres, metasoma with 7 exposed terga	2
1'	Female: antenna with 10 flagellomeres, metasoma with 6 exposed terga	29
2	Vertex with micropore field present as a small oval or circular patch between lateral ocellus and eye margin (Fig. 14)	3
2'	Vertex with micropore field forming a narrow linear furrow between lateral ocellus and eye margin (Figs. 50, 58)	24
3	Scutum with at most median scutal groove complete (Figs. 3, 15, 43, 71, 79); notauli attenuated posteriorly, not reaching posterior scutal margin except in a few cases by weak extensions; median scutal groove usually incomplete, sometimes reduced to a small pit on posterior scutal margin, or absent, or sometimes contiguous with admedian lines	4
3'	Scutum with 3 complete grooves (Figs. 23, 31); notauli reaching posterior scutal margin, not attenuated posteriorly; median scutal groove reaching admedian lines, not attenuated anteriorly	20
4	Preomalar area sparsely setose with underlying sculpture clearly evident; median scutal groove present at least as a small pit on posterior margin; labrum quadrilobed	5
4'	Preomalar area densely setose, with underlying sculpture obscured; posterior scutal margin with a series of evanescent striae; labrum bilobed; se. Brazil	<i>Incastigmus</i>
		<i>Llaqhastigmus mantanti</i> Finnamore
5	Mesosoma with at least pronotum red, sometimes entirely red	6
5'	Mesosoma black, at most pronotal lobe slightly red	7
6	Transverse pronotal carina with prominent tooth at humeral angle (Figs. 70–72); median scutal groove and notauli extending over most of scutum (Fig. 71); Costa Rica, Colombia, Ecuador, Peru, Trinidad	19. <i>pyrrhopyxis</i> new species
6'	Transverse pronotal carina rounded at humeral angle, without tooth; no median scutal groove and notauli restricted to anterior third; Lesser Antilles: Dominica, Grenada, St. Vincent	22. <i>thoracicus</i> (Ashmead)
7	Gena with tooth-like projection, ventrally (Fig. 12a); Peru, Ecuador, Colombia, Brazil (Mato Grosso)	6. <i>hexagonalis</i> (Fox)
7'	Gena smoothly rounded, without swellings, ventrally	8
8	First metasomal tergum dull, densely microsculptured; se. Brazil	18. <i>pynoglypticus</i> new species
8'	First metasomal tergum shiny, without microsculpture	9
9	Median scutal groove reduced, present only posteriorly and not reaching admedian lines (Figs. 8, 43).	10
9'	Median scutal groove well developed, reaching and often contiguous with admedian lines. (Figs. 3, 15, 79)	14

- 10 Pronotal lobes white ..... 11
- 10' Pronotal lobes black, occasionally brown or yellow-brown ..... 12
- 11 Pronotal lobe rounded (Figs. 42, 44); Central America ..... 13. *mystaxalbus* new species
- 11' Pronotal lobe toothed; South America ..... 24. *urqicus* new species
- 12 Transverse pronotal carina with tooth at humeral angle larger than tooth on vertical pronotal carina; southern Mexico (Quintana Roo) to Panama .... 25. *zephyrus* new species
- 12' Transverse pronotal carina with tooth at humeral angle smaller than tooth on vertical carina; South America ..... 13
- 13 Vertex, posterior to micropore field, with shallow elliptical depression defined posteriorly by weak carina; flagellomeres II-VI or more elongate, depressed basally, each with a broad shiny tylus on apical half; Ecuador, Peru, Bolivia, Brazil (Pernambuco) ..... 12. *mauracis* new species
- 13' Vertex, posterior to micropore field, flat, without depression; flagellomeres cylindrical, not depressed basally; Venezuela, Ecuador ..... 5. *chiucha* new species
- 14 Flagellomeres elongate, about 2x width, without tyli (Fig. 77); flagellomere XI broadly curved, more than 2x width; notauli extending  $\frac{2}{3}$  length of scutum (Fig. 79); se. Brazil ..... 21. *sunicerus* new species
- 14' Flagellomeres relatively short, length subequal to width or, if elongate, then rarely 2x width and flagellomere XI cylindrical, not curved; tyli often present (Fig. 1); notauli often approaching posterior margin of scutum ..... 15
- 15 Hypersternaulus much narrower than scrobal sulcus; raised, linear tyli on flagellomeres III or IV to VII; Brazil (Ceara) ..... 3. *cearaensis* new species
- 15' Hypersternaulus equal to or wider than scrobal sulcus (measured vertically) (Fig. 16); flagellomeres usually without tyli, or tyli obscure ..... 16
- 16 Vertex, gena and posterior  $\frac{2}{3}$  of scutum shiny, without microsculpture; median scutal groove tapered to a point just posterior to apex of admedian lines; Trinidad, Venezuela, Panama, Colombia, Ecuador, Bolivia, Brazil (Goiás) ..... 17. *prophorodontis* new species
- 16' Either vertex, gena or scutum dull, with microsculpture; median scutal groove reaching admedian lines ..... 17
- 17 Pronotal lobe toothed in dorsal view, forming a sharp acute angle, or flattened and wing-like in frontal view (Figs. 38-40); Colombia, to Bolivia, Brazil (Amazonas) ..... 11. *kunkopteryx* new species
- 17' Pronotal lobe rounded in dorsal or frontal view, forming an obtuse angle (Figs. 15, 16) ..... 18
- 18 Scutum striatopunctate on posterior  $\frac{2}{3}$ ; Peru ..... 2. *caelukhus* new species
- 18' Scutum more or less smooth, without striae between grooves ..... 19
- 19 Flagellum with tyli (Fig. 29), or ventral brush of setae (Figs. 69, 81) ..... 20
- 19' Flagellum without tyli (at least not visible in profile) and without ventral brush of setae (Fig. 13); south of Guiana Shield to Brazilian Highlands ..... 7. *ictericornis* new species
- 20 Flagellum with short, ventral setal brush (Figs. 69, 81); tyli absent, flagellomere XI symmetrical ..... 21
- 20' Flagellum without setal brush (Figs. 21, 29); tyli usually present, flagellomere XI often asymmetrical due to ventral tylus (Fig. 22) ..... 23
- 21 Mesosoma with at least pronotum red, sometimes entirely red; Costa Rica, Colombia, Ecuador, Peru, Trinidad ..... 19. *pyrrhopyxis* new species
- 21' Mesosoma black ..... 22
- 22 Vertex and frons uniformly microsculptured, dull; scutum with irregular striae on posterior  $\frac{2}{3}$ ; Peru ..... 2. *caelukhus* new species
- 22' Vertex, anterior to mid ocellus, shiny (Fig. 82), microsculpture denser on frons than on vertex; scutum with striae usually less developed and only between notauli; se. Brazil, Paraguay, Peru Ecuador, Colombia, Venezuela, Suriname ... 23. *trichodocerus* new species
- 23 Flagellomere XI unmodified, cylindrical, without tylus (Fig. 30); Peru, Bolivia, Paraguay, Brazil (Bahia, Goiás, Mato Grosso, São Paulo) ..... 10. *iphis* new species

- 23' Flagellomere XI with tylus on ventral surface imparting an asymmetrical shape (Fig. 22); Colombia, Ecuador, Peru, Bolivia, Brazil (Mato Grosso, Para) . . . . . 9. *inti* Finnermore
- 24 Tyli of flagellomeres I-XI with sparse, short brush of setae (Figs. 69, 81); Argentina, Bolivia, Brazil (São Paulo) . . . . . 16. *paranicus* new species
- 24' Tyli of flagellomeres without setal brush (Fig. 57), at most a few setae at apices of tyli (Fig. 49) . . . . . 25
- 25 Propodeum irregularly striate, without areolae; Venezuela. . . . . 20. *strepsilincatus* new species
- 25' Propodeum areolate (Fig. 59) . . . . . 26
- 26 Pronotal lobe with carinate tooth or peg-like projection (Figs. 50–52) . . . . . 27
- 26' Pronotal lobe rounded, if somewhat pointed then not carinate (Figs. 59,60) . . . . . 28
- 27 Pronotal lobe toothed (acutely produced), white (Figs. 50–52); Venezuela, Colombia, Bolivia, Brazil (Mato Grosso, Minas Gerais, Pernambuco, Rio de Janeiro) . . . . . 14. *mytior* new species
- 27' Pronotal lobe peg-like (bluntly produced), brown; Peru . . . . . 4. *ceromus* new species
- 28 Flagellomere XI with tylus imparting an asymmetrical shape; Argentina, Bolivia, se. Brazil . . . . . 1. *aylaxiter* new species
- 28' flagellomere XI cylindrical, symmetrical, with at most indistinct tylus (Fig. 57); Mexico to Argentina . . . . . 15. *neotropicus* (Kohl)
- 29 Median clypeal lobe with 2 elongate setae arising from subapical semicircular depression (Figs. 18, 37, 38, 85, 86) . . . . . 30
- 29' Median clypeal lobe with 2 elongate setae arising from 2 narrowly separated subapical pits or a broad transverse depression (Figs. 10, 46, 62, 74) . . . . . 33
- 30 Mesopleuron shiny, hypopimeral area unsculptured on ventral half or more, dorsal half finely microsculptured (Fig. 88); pronotal lobe rounded, conical (Fig. 87); scutum shiny posteriorly, often with short longitudinal irregular grooves (Figs. 87, 88); stigma of fore wing orange, brown or black; se. Brazil, Paraguay, Peru, Ecuador, Colombia, Venezuela, Suriname . . . . . 23. *trichodocerus* new species
- 30' Mesopleuron dull, microsculptured throughout (Fig. 20), **OR** pronotal lobe dorsally flattened (not conical), somewhat carinate anteriorly and laterally, **OR** posterior  $\frac{2}{3}$  of scutum with coarse regular striae; stigma of fore wing brown or black . . . . . 31
- 31 Scutum multistriate on posterior  $\frac{2}{3}$ ; mesopleuron shiny in part; pronotal lobe conical, not flattened or carinate; Peru . . . . . 2. *caelukhus* new species
- 31' Scutum without multiple striae except occasionally along posterior margin (Figs. 19, 39); mesopleuron microsculptured throughout **OR** pronotal lobe dorsally flattened, somewhat carinate anteriorly and laterally (Figs. 39–40) . . . . . 32
- 32 Pronotal lobe toothed, flattened dorsally, somewhat carinate anteriorly and laterally (Figs. 38–40); hypopimeral area shiny (Fig. 40); Colombia to Bolivia, Brazil (Amazonas) . . . . . 11. *kunkopteryx* new species
- 32' Pronotal lobe rounded, conical, without carinae (Figs. 19–20); hypopimeral area dull, microsculptured throughout (Fig. 20); south of Guiana shield to Brazilian Highlands . . . . . 7. *ictericornis* new species
- 33 Median scutal groove absent, indistinguishable from other grooves along posterior margin (Fig. 47) . . . . . 34
- 33' Median scutal groove present, at least as an elongate pit on posterior margin (Figs. 27, 63) . . . . . 36
- 34 Clypeus white or yellow in apical third; mesosoma and petiole black; Central America . . . . . 13. *mystaxalbus* new species
- 34' Clypeus black; mesosoma and petiole black to extensively red . . . . . 35
- 35 Median clypeal lobe absent; mesosoma and petiole usually extensively red; pronotal lobe white; Lesser Antilles: Dominica, Grenada, St. Vincent . . . . . 22. *thoracicus* (Ashmead)
- 35' Median clypeal lobe present; mesosoma and petiole black, sometimes partially red on

	pronotum, scutum, scutellum, and mesopleuron; pronotal lobe yellow to red; southern Mexico (Quintana Roo) to Panama	25. <i>zephyrus</i> new species
36	Gena with ventral tooth (Fig. 12a); Brazil (Mato Grosso), Peru, Ecuador, Colombia	6. <i>hexagonalis</i> (Fox)
36'	Gena smoothly rounded ventrally, at most with small swelling	37
37	Scutum red	38
37'	Scutum all black, or red posteriorly	39
38	Clypeus lateral to median lobe, simple, without tooth (Fig. 74); Costa Rica, Colombia, Ecuador, Peru, Trinidad	19. <i>pyrrhopyxis</i> new species
38'	Clypeus quadridentate, median lobe emarginate, bilobed, and flanked by small lateral tooth; Panama	8. <i>ignithorax</i> new species
39	First metasomal tergum dull, with dense, coarse microsculpture; se. Brazil	18. <i>pyncoglypticus</i> new species
39'	First metasomal tergum shiny, without or with little microsculpture	40
40	Pronotal lobe red, brown or black	41
40'	Pronotal lobe white	44
41	Gena ventrally with small, subconical swelling near hypostomal carina; Trinidad, Venezuela, Panama, Colombia, Ecuador, Bolivia, Brazil (Goias)	17. <i>prophorodontis</i> new species
41'	Gena ventrally flat, without swelling near hypostomal carina	42
42	Lateral clypeal tooth located beneath antennal socket and separated from median lobe by deep emargination (Fig. 6); Venezuela, Ecuador	5. <i>chinchu</i> new species
42'	Lateral clypeal tooth, if present, forming part of the median lobe, not distinct and not separated by emargination, appearing as a small basolateral angle on the median lobe	43
43	Pronotal lobe black or dark brown-black; lateral clypeal tooth present laterad of median clypeal lobe; Ecuador, Peru, Bolivia, Brazil (Pernambuco)	12. <i>mauracis</i> new species
43'	Pronotal lobe yellow-brown; lateral clypeal tooth absent; Brazil (Minas Gerais)	24. <i>urqicus</i> new species
44	Pronotal lobe toothed, peg-like or sharply acute (Figs. 38–40, 50–52)	45
44'	Pronotal lobe rounded (Figs. 25, 27, 28, 35, 36)	47
45	Pronotal lobe with peg-like projection; median scutal groove reaching admedian lines; notauli often elongate, attenuating near posterior scutal margin; Peru	4. <i>ceronius</i> new species
45'	Pronotal lobe acute or dorsally flattened, wing-like; scutal grooves variable (Fig. 55)	46
46	Median scutal groove reaching admedian lines; notauli elongate (Fig. 39); pronotal lobes sometimes dorsally flattened (Fig. 38); Peru, Colombia	11. <i>kunkopteryx</i> new species
46'	Median scutal groove and notauli short, incomplete (Fig. 55); pronotal lobe conical, acute; Venezuela, Colombia, Bolivia, Brazil (Mato Grosso, Minas Gerais, Pernambuco, Rio de Janeiro)	14. <i>mytior</i> new species
47	Scutum with 3 complete grooves, notauli reaching posterior scutal margin (Fig. 27); scutum shiny, microsculptured usually along anterior margin only	48
47'	Scutum with at most median groove complete (Fig. 67), notauli short; scutum usually microsculptured	49
48	Vertex anterolaterally to mid ocellus shiny, without microsculpture (Fig. 25); Colombia, Ecuador, Peru, Bolivia, Brazil (Mato Grosso, Para)	9. <i>inti</i> Finnamore
48'	Vertex anterolaterally to mid ocellus dull, microsculptured (Fig. 33); Peru, Bolivia, Paraguay, Brazil (Bahia, Goias, Mato Grosso, São Paulo)	10. <i>iphis</i> new species
49	Lower hypoepimeral area shiny, without microsculpture; mid mesopleural area shiny and relatively large due to moderate and small size of foveae of scrobal sulcus, hypersternaulus and omaulus (Fig. 68); occipital carina not raised ventrally (Fig. 68); antenna beyond flagellomere II blackened, apical flagellomeres black; clypeal setae sparse, not obscuring underlying sculpture and clypeus punctures widely scattered (Fig. 66); Argentina, Bolivia, Brazil (São Paulo)	16. <i>paranicus</i> new species

- 49' Lower hypoepimeral area and mid mesopleural area microsculptured or shiny, the latter relatively small due to comparatively large size of foveae of scrobal sulcus, hypersternaulus and omaulus (Fig. 64); occipital carina often slightly raised ventrally (Fig. 64); antenna usually yellow to brown, seldom blackened; clypeal setae variable, scattered and not obscuring underlying microsculpture, to dense and obscuring underlying sculpture (Fig. 62); Mexico to Argentina ..... 50
- 50 Head and mesosoma extensively microsculptured, usually entirely; scutum punctate, often obscurely; clypeal setae sparse, not obscuring sculpture; Argentina, Bolivia, se. Brazil ..... 1. *aylaxiter* new species
- 50' Vertex adjacent to ocelli, scutum, lower hypoepimeral area and mesopleuron often shining (Fig. 64); scutum punctate to coarsely striatopunctate (Fig. 63); clypeal sculpture often obscured by dense appressed setae (Fig. 62) ..... 51
- 51 Micropore field of vertex small, elongate-triangular, usually much longer than wide, width about  $\frac{1}{3}$  ocellular distance or less (Fig. 61); clypeus usually concealed by dense appressed setae (Fig. 62); USA (Texas) to Argentina ..... 15. *neotropicus* (Kohl)
- 51' Micropore patch of vertex large, circular, extending about half ocellular distance; clypeus with sparse setae that do not obscure sculpture; se. Brazil ... 21. *sumicerus* new species

### 1. *Incastigmus aylaxiter* Finnermore new species

*Derivation of Name.*—The species epithet is derived from two Greek words, *aylax*, meaning groove, and *iter*, meaning passage, in reference to the median scutal groove found in this species.

*Diagnosis.*—Males of *aylaxiter* can be recognized on the basis of the narrow linear micropore field between the compound eye and lateral ocellus, flagellomeres without a ventral setal brush, tylus on flagellomere XI imparting an asymmetrical appearance, and the rounded pronotal lobe. Females are difficult to recognize, but the following combination of characters should prove useful: median clypeal lobe with 2 narrowly separated subapical pits, clypeus not obscured by appressed setae, vertex microsculptured throughout, scutum with median groove not reaching admedian lines, notauli short and not reaching scutal midlength, pronotal lobe rounded and white, hypoepimeral area microsculptured throughout, and metasomal tergum 1 shiny. This species most resembles *paranicus* and *neotropicus*. Males are easily distinguished from other species using the diagnostic characters. Females of *aylaxiter* are separated from *paranicus* on

the basis of the entirely microsculptured hypoepimeral area (in *paranicus* the lower hypoepimeral area is shiny), and separated from *neotropicus* on the basis of the less extensively setose clypeus (clypeus usually obscured by relatively dense appressed setae in *neotropicus*) and by its distribution which is apparently restricted to the Southern half of South America, whereas *neotropicus* ranges from Argentina to USA (Texas).

*Male.*—Length 3.5–4.0 mm. HEAD. Flagellomeres without ventral brush of setae; narrow linear tyli present on flagellomeres I to XI, tylus on flagellomere XI imparting asymmetrical appearance and truncate tip; flagellomere I length  $1.3 \times$  maximum width as measured with tylus in profile; flagellomere X length  $1.1 \times$  maximum width as measured with tylus in profile. Clypeus obscured by dense appressed setae which extend up frons along inner margins of eyes to slightly less than height of scape; frons, vertex and gena entirely microsculptured; punctures of frons sparse, irregular, 2 or more diameters apart; punctures of gena obscured, more regular in ventral region, 3 or more diameters apart, without ventral tooth or swelling; narrow linear micropore field present between compound eye and lat-

eral ocellus, without depression behind it; OOD  $1.4 \times$  LOD. MESOSOMA. Transverse pronotal carina forming a right angle at humeral angle, toothed ventrally; transverse pronotal groove longitudinally striate; pronotal lobe rounded, with weak anterior carina; lateral pronotal area longitudinally striate. Scutum uniformly microsculptured with sparse, irregular punctures, 2 or more diameters apart in mid region; median scutal groove extending to scutal midlength, but not reaching admedian lines; notauli attenuated near scutal midlength; posterior margin of scutum with a series of short irregular striae. Scutellum microsculptured with faint median groove and several punctures in lateral area. Setae of preaular area sparse, not obscuring sculpture. Mesopleuron microsculptured, punctures not evident; hypersternaulus, scrobal sulcus, and omaulus foveolate. Metapleuron microsculptured with longitudinal striae along posterior margin. Propodeum shiny, with weak microsculpture, areolate, except for shiny, partially striate region adjacent to metapleuron; propodeal enclosure defined by raised carina separating it from the lateral sphere. METASOMA. First tergum shiny, without microsculpture, with minute, sparse punctures; succeeding terga with an oily sheen, with relatively larger punctures, 5 or more diameters apart. Sterna shiny, with oily sheen, with sparse punctures on basal sterna, but reaching greatest density on sternum VI where they are about 1 diameter apart. COLOR. Black. White: mandible, basal half; pronotal lobe. Yellow-brown: palpi; mandible, except base and apex; antenna, except flagellomeres VI-XI; tegula; fore leg, except coxa and femur; mid leg, except coxa and femur; hind trochanter and hind tarsus.

*Female*.—Length 4.0–5.0 mm. Similar to male except as follows: flagellomeres without tyli or specialized setae; flagellomere I length  $1.7 \times$  maximum width; clypeus shiny, setae more dense than in other species, but not obscuring sculpture,

with punctures on median area 1 to 2 diameters apart; median clypeal lobe with 2 teeth separated by narrow emargination and a pair of narrowly separated subapical pits; sculpture of frons along inner margin of eyes not obscured by appressed setae; micropore field present as an elongate triangle between compound eye and lateral ocellus; OOD  $1.8 \times$  LOD.

*Material Examined*.—70 ♂, 119 ♀. HOLOTYPE MALE: Brazil: M.G. Ouro Preto IV-1954 N.L.H. Krauss (USNM). Paratypes: **ARGENTINA: Buenos Aires:** Buenos Aires: 18-IV-1912 J.B. (1♂ MACN); 4-V-1912 J.B. (1♀ MACN); 2-V-1915 J.B. (1♂ MACN); Moreno, Fritz (2♀ IIES). Punta Lara 26-I-1968 H. & M. Townes (1♂ AEIC). **Catamarca:** La Merced 26-VIII-1968 L. Pena (1♂ AEIC). Palo Labrado 27-III-1971 Fidalgo (1♂ IMLA). **Cordoba/Catamarca:** Cordoba, Copacabana Fritz (2♂ IIES). **Jujuy:** Ledesma Fritz (1♂ IIES). Perico del Carmen 21-X-1968 L. Pena (4♂ CNCI). **La Rioja:** Cuesta de Miranda 2020m 15-XII-1971 Stange—Porter (1♂ IMLA). **Salta:** Cachi 20-22-I-1966 C. Porter (1♂ MCZC). Magdalena 23-I-1966 H. & M. Townes (1♀ AEIC). Oran, Abra Grande 18-25-X-1968 C. Porter (1♂ MCZC). Pocitos XII-1972 Fritz (1♂ IIES); XII-1971 Fritz (1♂ IIES). Rosario Lerma X-1984 Fritz (3♂ IIES). Tartagal A. Martines (1♂ IIES). **Tucuman:** Amaicha del Valle: 28-XII-1965 H. & M. Townes (1♂ AEIC); 29-XII-1965 H. & M. Townes (2♂ AEIC); 9-III-1966 Garcia—Porter (1♂ MCZC). Ciudad Tucuman 24-II-1952 A. Ogloblin (1♂ IIES); [no date] Ogloblin (1♂ IIES); 1-1906 Vezenvi (1♀ NHMW); Tucuman, Horco Molle 10-XI-1967 C. Porter (1♂ MCZC). **BOLIVIA:** (2♀ NHMW). Río Beni, [Rurrenabanque] X W.M. Mann, Mulford Bio. Expl. 1921–22 (1♂ USNM). **El Beni:** Cochabamba 10–4-1957 (2♀ FSAG). **BRAZIL:** [Brazilien] Fritz Muller, coll. G. Mayr (1♀ NHMW). **Amazonas:** R. Japura 13-IX-1904 Ducke (1♀ MPEG). **Bahia:** [Bim Fim] 21-XI-1907 (1♀ CMNH). [Liagoa Feia] 9-VI-1908 (1♀ CMNH). **Maranhao:** [Varanahao Codo]

17-VI-1901 Duce (1♀ MPEG). **Minas Gerais:** Barbacena 23-X-1905 Duce (1♀ MPEG). **Parana:** Campina Grande nr. Curitiba 10-II-1966 H. & M. Townes (1♀ AEIC). **Río de Janeiro:** Parque Nacional Serra da Bocaina, S.J. Barreiros: 4-7-XI-1967 1600m Alvarenga & Seabra (1♂ 1♀ AEIC); XI-1968 1650m Alvarenga & Seabra (1♂ 6♀ AEIC); 13-17-I-1969 1600m Porter & Garcia (1♂ MCZC); IV-1969 800m F.M. Oliviera (2♀ AEIC); XI-1969 800m F.M. Oliviera (1♀ AEIC). **Río de Janeiro** (1♀ CMNH). **Río de Janeiro, Theresopolis:** 9-X-1923 W.S. Bristowe B.M. 1967-510 (1♂ BMNH); 12-III-1966 H. & M. Townes (2♀ AEIC). **Santa Catarina:** Nova Teutonia: 27°11' B 52°23' L F. Plaumann (various dates) 1935-1967 (10♂ 10♀ BMNH, 2♂ 16♀ MCZC, 1♂ 3♀ OSUO); 27°11' B 52°23' L IX-1967 300-500m F. Plaumann (1♀ MCZC); 27°11' B 52°23' L VI-1968 300-500m F. Plaumann (1♂ MCZC). **São Paulo:** S. Bocaina III-1973 (2♀ PMAE). São Paulo 1928 Bury J. Gyorgy (1♀ HNHM); (various dates) 1968-1969 V.N. Alin (1♂ 17♀ USNM); (various dates) 1969-1982 (21♂ 41♀ ZMUM).

## 2. *Incastigmus caelukhus* Finnamore new species

*Derivation of Name.*—The name *caelukhus* is derived from two words, the Latin *caelo*, meaning to engrave, and the Quichuan term, *ukhu*, meaning body, in reference to the striatopunctate scutum of this species.

*Diagnosis.*—Males of this species can be recognized by the irregularly ridged, striatopunctate scutum with complete or nearly complete median scutal groove and notauli, the uniformly microsculptured frons and vertex, and the ventral brush of setae on the flagellomeres. Females can also be recognized by the ridged, striatopunctate sculpture of the scutum, the uniformly microsculptured frons and vertex, and the semicircular depression on the median clypeal lobe from which long setae arise.

*Male.*—Length 3.5-4.0 mm. **HEAD.** Flagellomeres with a ventral brush of short

fine setae, tyli absent; flagellomere I length  $1.8 \times$  apical width; flagellomere X length  $1.2 \times$  apical width; flagellomere XI straight, cylindrical, apex conical. Clypeus obscured by dense appressed setae which extend up frons along inner eye margin to height of antennal socket; frons and vertex dull, microsculptured, with sparse, irregular, punctures, 3 or more diameters apart; gena microsculptured, obscurely punctate, without ventral tooth or swelling; micropore field present between compound eye and lateral ocellus, without depression behind it; lateral ocelli closer to each other than to eyes; OOD  $1.3 \times$  LOD. **MESOSOMA.** Transverse pronotal carina ending in a right angle at humeral angle, toothed ventrally; transverse groove longitudinally striate; pronotal lobe rounded without anterior carina; lateral pronotal area longitudinally striate. Scutum ridged, striatopunctate, less so on lateral areas, microsculptured on anterior third, otherwise shiny; median scutal groove contiguous with admedian lines, notauli contiguous to posterior margin. Scutellum microsculptured, with median sulcus, and scattered lateral punctures. Preaular area anteriorly with sparse setae, sculpture visible. Mesopleuron with weak microsculpture, mostly shiny; hypersternaulus, scrobal sulcus, and omaulus, coarsely foveolate. Metapleuron shiny, weakly microsculptured, with short longitudinal striae along posterior margin. Propodeum shiny, coarsely areolate, except area adjacent to metapleuron which is shiny, unsculptured; propodeal enclosure not differentiated from lateral spheres. **METASOMA.** Terga shiny with an oily sheen, with minute, obscure, punctures; sterna shiny, sparsely punctate, with punctures not increasing in density on posterior sterna. **COLOR.** Black. White: mandible, except apex; pronotal lobe. Yellow-brown: palpi; antenna; tegula; fore leg, except coxa; mid leg, except coxa; hind trochanter and tarsus.

*Female.*—Length 4.0-4.5 mm. Similar to

male except as follows: flagellomere I length  $1.3 \times$  apical width. Clypeus shiny, sparsely punctate and sparsely setose; median clypeal lobe truncate, without teeth, with a large subapical semicircular depression from which a pair of long setae arise; frons along inner eye margin obscured by appressed setae; OOD  $1.7 \times$  LOD; color as in male, except 1 specimen which has a red prothorax.

*Material Examined.*—3 ♂, 2 ♀. HOLOTYPE FEMALE: Peru: 10km S. Chiclayo 19-III-1951 Ross & Michelbacher (CASC). Paratypes: **PERU**: 10km S. [Chiclayo] 19-III-1951 Ross & Michelbacher (2♂ CASC). **Lambayeque**: 18km E. Olmos 22-VII-1982 R.B. Miller, L.A. Stange (1♀ FSCA). **Piura**: Piura 1-XI-1910-7-I-1911 C.H. Townsend, Leher (1♂ USNM).

### 3. *Incastigmus cearaensis* Finnamore new species

Figs. 1-4

*Derivation of Name.*—*Cearaensis* is named in reference to the state of Ceara in Brazil, from where most of the specimens in this study have been collected.

*Diagnosis.*—The narrow hypersternaulus and the presence of tyli on flagellomeres III to V will distinguish the male of this species from others in the genus. The female is unknown.

*Male.*—Length 3.5-4.0 mm. HEAD. Flagellomeres without specialized setae; linear tyli present on flagellomeres I to V or VII; flagellomere I length  $1.5 \times$  apical width; flagellomere X length  $1.3 \times$  apical width; flagellomere XI straight, cylindrical, apex conical. Clypeus obscured by dense appressed setae which extend up frons along inner margin of eye to about height of antennal socket; head entirely microsculptured, slightly less so on vertex; punctures strong, sparse, three or more diameters apart on vertex; gena microsculptured, with punctures in lower area 3 or more diameters apart, without ventral tooth or swelling; small oval micropore field evident between compound eye and

lateral ocellus; without depression behind it; lateral ocelli slightly closer to eyes than to each other; OOD  $1.4 \times$  LOD. MESOSOMA. Transverse pronotal carina toothed at humeral angle, and toothed ventrally; transverse pronotal groove longitudinally striate; pronotal lobe rounded, without anterior carina; lateral pronotal area longitudinally striate. Scutum microsculptured, dull, with several longitudinal striae along posterior margin; notauli attenuated near scutal midlength; median scutal groove present posteriorly, attenuated near scutal midlength; scutal punctures strong, sparse, 1 or more diameters apart. Scutellum microsculptured, with several punctures in median lateral area. Preomalar area anteriorly with sculpture visible and sparse setae. Mesopleuron microsculptured, dull, with sparse, obscure, punctures; hypersternaulus narrow, linear, with relatively fine foveae; scrobal sulcus, and omaulus coarsely foveolate; metapleuron dull, microsculptured, with several short longitudinal striae along posterior margin. Propodeum shiny, with weak microsculpture, coarsely areolate, except area adjacent to metapleuron which has fine microstriate sculpture; propodeal enclosure not differentiated from lateral spheres. METASOMA. Tergum I shiny with weak microsculpture; succeeding terga with oily sheen, punctures sparse, obscure, many diameters apart. Sterna shiny with weak microsculpture imparting an oily sheen, punctures obscure, sparse, 3 or more diameters apart. COLOR. Black. White: pronotal lobe. Yellow-brown: palpi; mandible, except apex; antenna; fore leg, except coxa; mid leg, except coxa; hind tarsus; apical sterna.

*Female.*—Unknown.

*Material Examined.*—4 ♂. HOLOTYPE MALE: Brazil: SP, Faz. Campininas, Mogi Guacu 29-31-XII-1969 JM & BA Campbell (CNCI). Paratypes: **BRAZIL**: **Ceara**: Ser-rado Araripe, Crato V-1969 M. Alvarenga (3♂ PMAE).

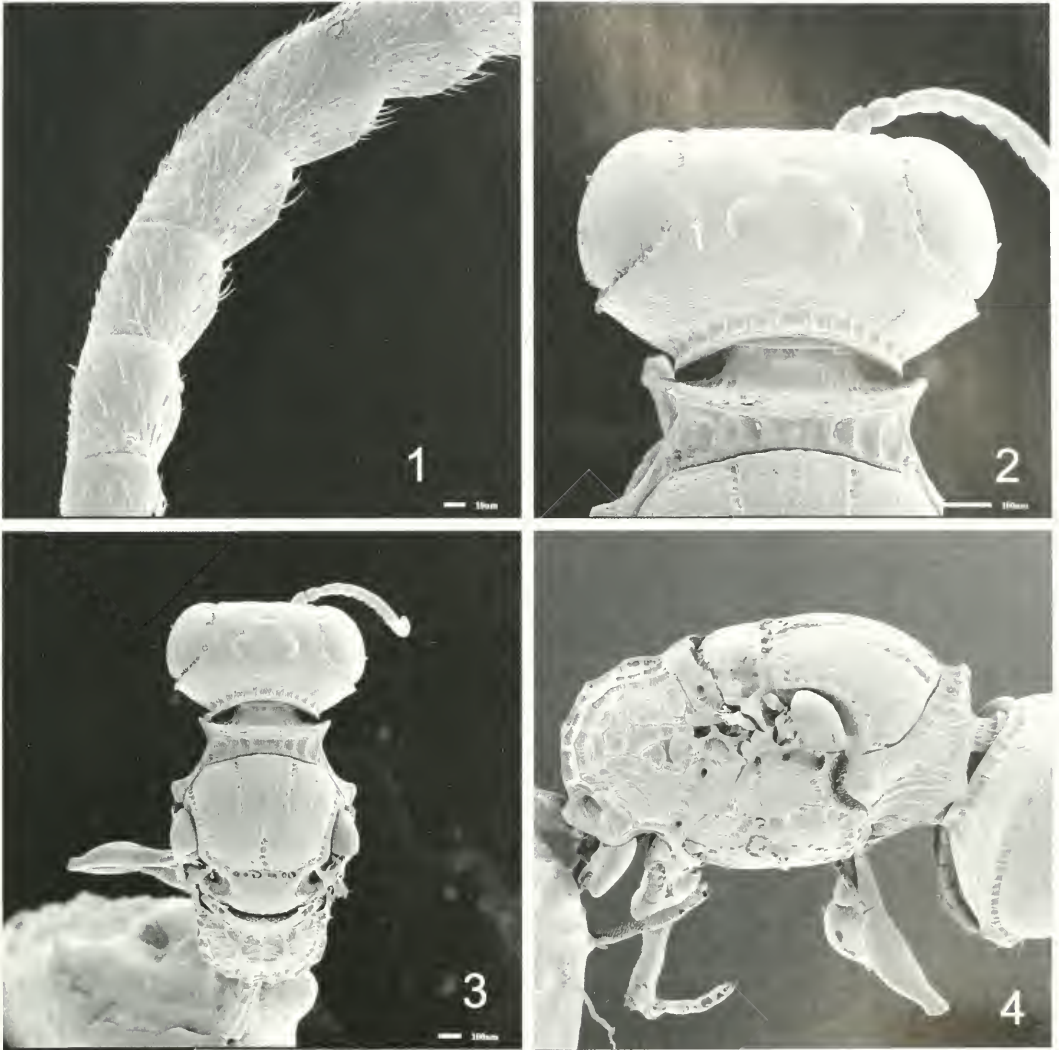

Figs. 1–4. *Incastigmus ceiraensis* ♂. 1, Mid flagellomeres of antenna. 2, Head, dorsal; arrow indicates micro-pore field. 3, Mesosoma, dorsal. 4, Mesosoma, lateral (tooth on mesopleuron is an artifact).

#### 4. *Incastigmus ceromus* Finnamore new species

*Derivation of Name.*—The species epithet is a derivation of two Greek words, *keros*, meaning horn, and *omos*, meaning shoulder, in reference to the peg-like pronotal lobe of this species.

*Diagnosis.*—This species has the greatest development of the pronotal lobe of any species in the genus. The blunt, peg-like pronotal lobe in both males and females separates *ceromus* from all other *Incastig-*

*mus*. In addition, the male pronotal lobe is brown, and the vertex has a linear micro-pore field between the compound eye and lateral ocellus; in the female the micro-pore field is an elongate triangle, the pronotal lobe is white, and notauli do not reach the posterior scutal margin, but attenuate on the posterior half of the scutum.

*Male.*—Length 4.5 mm. HEAD. Flagellomeres setose throughout, but without specialized ventral brush of setae, at most with a few specialized setae on the apices

of the flagellomeres; all flagellomeres with linear tyli; tylus on flagellomere XI imparting a slight asymmetrical appearance and blunt tip; flagellomere I length  $1.2 \times$  maximum width as measured with tylus in profile; flagellomere X length  $1.2 \times$  maximum width as measured with tylus in profile. Clypeus obscured by dense appressed setae which extend up frons along inner margins of eyes to approximately half height of scape; frons coarsely microsculptured, somewhat shiny anterior to ocelli and on vertex; punctures of upper frons and vertex sparse, irregular, 3 or more diameters apart; vertex, posterior to ocelli, microstriate; gena microsculptured, longitudinally striate on lower half, without ventral tooth or swelling; linear micropore field present between compound eye and lateral ocellus; without depression behind it; OOD  $1.7 \times$  LOD. **MESOSOMA.** Transverse pronotal carina toothed at humeral angle and toothed ventrally; transverse pronotal groove longitudinally striate; pronotal lobe produced as blunt peg-like projection with strong anterior carina; lateral area of pronotum longitudinally striate. Scutum microsculptured, punctures small, sparse, irregular, 1 to many diameters apart in midregion; notauli extending to near scutal midlength, attenuating on posterior half, not reaching posterior margin; median scutal groove attenuating at admedian lines; posterior margin of scutum with a series of ridges extending to posterior quarter of scutum. Scutellum microsculptured, with median longitudinal sulcus and sparse scattered punctures. Sculpture of preomalar area not obscured by setae. Mesopleuron with microsculpture in dorsal region, shiny, weakly microsculptured ventrally; hypersternaulus, scrobal sulcus, and omaulus coarsely foveolate. Metapleuron microsculptured, with several longitudinal striae along posterior margin. Propodeum shiny, without microsculpture, areolate except small microstriate region adjacent to metapleuron; propodeal enclosure not

differentiated from lateral spheres. **META-SOMA.** First tergum shiny with minute obscure punctures; succeeding terga with an oily sheen, punctures sparse, minute, obscure. Sterna shiny, with oily sheen, punctures sparse on basal sterna, not increasing in density until sternum VI where they are about 2 diameters apart in median region. **COLOR.** Black. Yellow-brown: palpi; mandibles, except apex; antenna, except apical flagellomeres; tegula; pronotal lobe; fore leg, except coxa; mid leg, except coxa; hind tarsus; apical sternum and tergum.

*Female.*—Length 4.0–5.0 mm. Similar to male except as follows: flagellomeres without tyli or specialized setae; flagellomere I length  $1.5 \times$  maximum width; clypeus shiny, with weak microsculpture, punctures sparse in median region and 1 or more diameters apart; median clypeal lobe with 2 blunt teeth separated by a shallow notch, and with 2 narrowly separated subapical pits; sculpture of frons along inner margins of eyes not obscured by setae; upper frons and vertex more shiny than in male, microstriae not as evident; gena more shiny than in male, microsculpture weak ventrally, longitudinal striae on lower half present to absent; micropore field present as an elongate triangle between compound eye and lateral ocellus; OOD  $2.2 \times$  LOD; scutum with weak microsculpture on posterior half, more shiny than in male; pronotal lobe white.

*Material Examined.*—2 ♂, 7 ♀. **HOLOTYPE MALE:** Peru: Carpish Mts. 40mi S. Tingo María 28-XII-1954 E.I. Schlinger & E.S. Ross (CASC). Paratypes: **PERU: Cuzco:** Río Urubamba 3km above Machu Picchu 2050m 18-IV-1983 C. & M. Vardy B.M. 1983–217 (1 ♀ BMNH). Machu Picchu museum 1,385m 11-14-VIII-1971 C. & M. Vardy B.M. 1971–533 (1 ♀ BMNH). Agua Caliente 21-28-XII-1983 (1 ♀ PMAE). **Huanuco:** Carpish Mts. 40mi S. Tingo María 28-XII-1954 E.I. Schlinger & E.S. Ross (3 ♀ CASC). 26mi E. Tingo María 10-XII-1954 1100m E.I. Schlinger & E.S. Ross (1♂

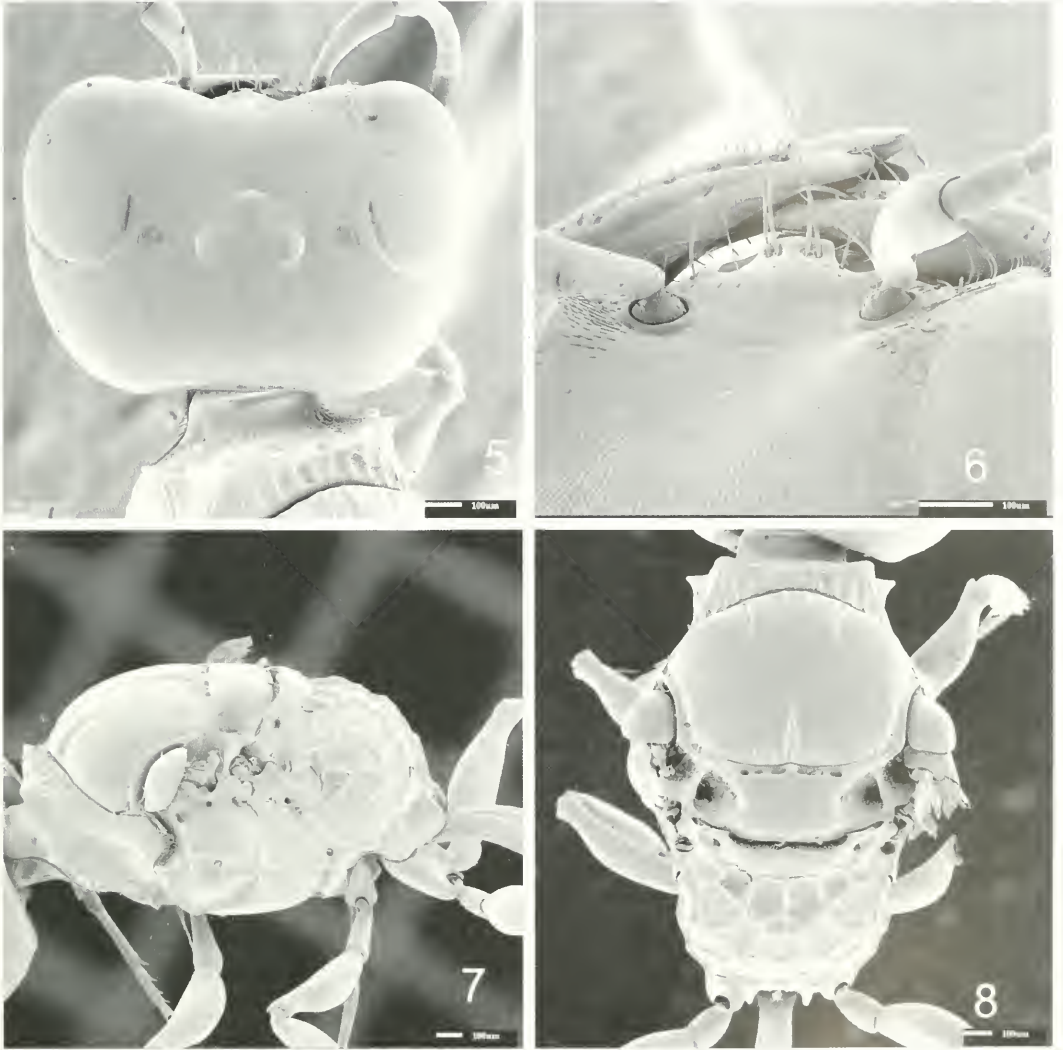

Figs. 5–8. *Incastignus chincha* ♀. 5, Head, dorsal. 6, Clypeus, oblique dorsal view. 7, Mesosoma, lateral. 8, Mesosoma, dorsal.

CASC). Pasco: Oxapampa 2,200m 7-III-1979 M. Cooper B.M. 1979-216 (1 ♀ BMNH).

**5. *Incastignus chincha* Finnamore  
new species**  
Figs. 5–8

*Derivation of Name.*—*Chincha* is a Quechuan term, meaning northern in reference to the distribution of this species in the northern part of South America.

*Diagnosis.*—Males of this species can be

recognized on the basis of the short median scutal groove, the dark, toothed pronotal lobe, and the absence of a depression posterior to the micropore field. Females can be recognized on the basis of the short median scutal groove, the dark, toothed pronotal lobe, and the acute lateral tooth on the apical margin of the clypeus.

*Male.*—Length 4.0 mm. HEAD. Flagellomeres without a brush of specialized setae or tyli; flagellomere I length 1.6 ×

apical width; flagellomere X length  $1.3 \times$  apical width; flagellomere XI straight, cylindrical, apex conical. Clypeus obscured by dense appressed setae which extend up frons along inner margin of eyes to a point about twice the height of antennal socket. Frons microsculptured, punctures not evident; vertex shiny, with microsculpture and punctures scattered, sparse, many diameters apart; gena microsculptured, more shiny than vertex, sparse punctures more evident ventrally, without ventral tooth or swelling; lateral ocelli closer to each other than to compound eyes; OOD  $1.5 \times$  LOD. **MESOSOMA.** Transverse pronotal carina toothed at humeral angle and toothed ventrally, transverse pronotal groove longitudinally striate, pronotal lobe with anterior carina ending in acute tooth; lateral region of pronotum longitudinally striate. Scutum microsculptured, somewhat shiny; punctures coarse, sparse, 3 or more diameters apart; notauli present anteriorly, attenuated posteriorly near scutal midlength, median groove present posteriorly, attenuated anteriorly, not reaching admedian lines; posterior margin of scutum with a series of short ridges parallel to, but shorter than, median groove. Scutellum microsculptured, with several punctures in median area, and a median longitudinal sulcus. Mesopleuron entirely microsculptured, apparently impunctate; preomaular area anteriorly with sculpture evident, setae sparse; hypersternaulus, scrobal sulcus, and omaulus coarsely foveolate. Metapleuron coarsely microsculptured with several longitudinal striae. Propodeum shiny, with weak microsculpture, coarsely areolate throughout, except area adjacent to metapleuron which is longitudinally striate; propodeal enclosure not differentiated from lateral spheres. **METASOMA.** Tergum I shiny, without microsculpture, punctures sparse, obscure. Terga beyond first tergum with oily sheen. Sterna shiny, with weak microsculpture;

punctures sparse, becoming increasingly dense on more posterior sterna; punctures of sternum VI about 1.5 diameters apart. **COLOR.** Black. Yellow-brown: palpi; mandible, except apically; antennae except apical flagellomeres; tegula; pronotal lobe; fore leg, except coxa; mid leg, except coxa; hind tarsus, hind trochanter, and apex of hind tibia; sterna VI to VIII.

*Female.*—Length 4.5–5.5 mm. Similar to male except as follows: flagellomere I length  $1.8 \times$  apical width; clypeus shiny with punctures sparse, more than 5 diameters apart medially; median clypeal lobe reduced to a narrowly rounded protrusion, median teeth not evident and median lobe with a pair of subapical circular pits from which several long setae arise; acute lateral tooth present on clypeal margin, situated below antennal socket; frons along inner eye margin not obscured by appressed setae. OOD  $2.2 \times$  LOD. Scutum and mesopleuron generally with less microsculpture, more shiny.

*Material Examined.*—2 ♂ 13 ♀. **HOLOTYPE FEMALE:** Venezuela: Aragua, Rancho Grande, Portachuelo 1100m 22-V-1981 J.L. Garcia & J. Clavijos (IZAV). **Paratypes:** **ECUADOR: Pichincha:** Tinalandia 800m II-1983 M. Sharkey & L. Masner (2♀ PMAE). 16km SE. Sto. Domingo 500m Tinalandia 4-14-VI-1976 S. & J. Peck (1♀ CNCI). **VENEZUELA: Aragua:** Rancho Grande, Portachuelo: 1100m 21-V-1981 J.L. Garcia & J. Clavijos (1♂ 2♀ IZAV); 1100m 22-V-1981 J.L. Garcia & J. Clavijos (3♀ IZAV). **Bolivar:** Kavanayen 20-X-1972 J. & B. Bechyne (1♀ IZAV). **Falcon:** [Cerrogalicia] 1500m 3-XII-1971 J. & B. Bechyne (1♀ IZAV). Cerro Galicia 1500m 19-XI-1971 J. & B. Bechyne (1♀ IZAV). **Lara:** Cubiro 6-V-1981 H.K. Townes (1♂ AEIC). **Merida:** Valle Grande 23-VII-1988 C. Porter & L. Stange (1♀ FSCA). **Trujillo:** La Mesa 26-VII-1966 J. & B. Bechyne (1♀ IZAV).

6. *Incastigmus hexagonalis* (Fox)  
new combination

Figs. 9–12

*Stigmus hexagonalis* Fox 1897:379. Lectotype, female CMNH. Brazil: Chapada, Dec; examined.

*Diagnosis.*—Both sexes can be easily recognized by the tooth-like projection on the ventral gena near the hypostomal carina. Females can be distinguished from female *prophorodontis*, which also have a small tooth-like swelling on the lower gena, by the presence of a pair of teeth on the median clypeal lobe; female *prophorodontis* have a truncate median clypeal lobe, without teeth.

*Male.*—Length 3.5–4.2 mm. HEAD. Flagellomeres without tyli, but with a ventral brush of setae; flagellomere I length  $2.0 \times$  apical width; flagellomere X length  $1.2 \times$  apical width; flagellomere XI straight, cylindrical, apex conical. Frons and clypeus with uniform microsculpture; vertex and gena shiny, with sparse punctures separated by 5 or more puncture diameters. Clypeus obscured by dense setae which extend up frons along eye margin to height of antennal socket. Gena shiny, without microsculpture, sparsely punctate, not striate, and with prominent ventral tooth-like swelling. Micropore field present as a discrete oval patch on vertex between lateral ocellus and compound eye, without a depression behind it. Ocelli closer to each other than to eyes. OOD  $1.6 \times$  LOD. MESOSOMA. Transverse pronotal carina with prominent tooth at humeral angle and prominent ventral tooth; transverse pronotal groove with several longitudinal striae. Pronotal lobe tooth-like, conical. Pronotum laterally striate. Scutum shiny, with microsculpture anteriorly. Notauli well developed, present on anterior half of scutum. Median groove of scutum well developed and complete, or sometimes attenuated anteriorly between admedian lines, broadened posteriorly. Posterior margin of scutum with several short

parallel striae on each side of the median groove. Scutellum shiny, with weak microsculpture, generally impunctate, but a small group of punctures present laterally. Mesopleuron shiny, without microsculpture, impunctate. Preomalar area anteriorly with sparse setae. Hypersternaulus coarsely foveolate, often with only two large foveae. Scrobal sulcus and omalar sulcus coarsely foveolate. Metapleuron weakly microsculptured on ventral half, otherwise shiny, impunctate. Propodeum shiny, without microsculpture; propodeal enclosure and lateral spheres not differentiated, coarsely areolate throughout, except basal area adjacent to metapleuron which is smooth and shiny, without sculpture. METASOMA. Terga shiny, without microsculpture; punctures sparse, obscure. Sterna shiny; punctures sparse, weak. COLOR. Black. Yellow-brown: antenna, except dorsal apex of flagellum; mandible, except apex; palpi; tegula; fore and mid legs, except coxae; hind coxal apex, hind trochanter, hind tibia ventrally, and hind tarsus.

*Female.*—Length 4.0–5.25 mm. Similar to male except as follows: flagellomere I length  $2.25 \times$  apical width. Clypeus shiny, without appressed setae, sparsely to densely punctate; median clypeal lobe with a pair of teeth separated by a deep U-shaped emargination; the base of each tooth bears a large pit from which arises an elongate seta. Lower gena with a prominent tooth-like swelling. OOD  $2.4 \times$  LOD. Occipital carina simple, not foveolate. Color as in male for the dark form, except pronotum, scutum, scutellum, and upper mesopleural area, orange-red in light form.

*Material Examined.*—3 ♂, 28 ♀. **COLOMBIA:** Caqueta: Yuruyaco, 73km SW. Florencia (BMNH). Meta: Río Duda (BMNH). Putumayo: Moco. (BMNH); Mocoa, 8mi S. Puerto Assis 350m (BMNH). **ECUADOR:** Morona: Macas, 6km E. Santiago, Cord. Cutucu (BMNH). Napo: Limoncocha (on Río

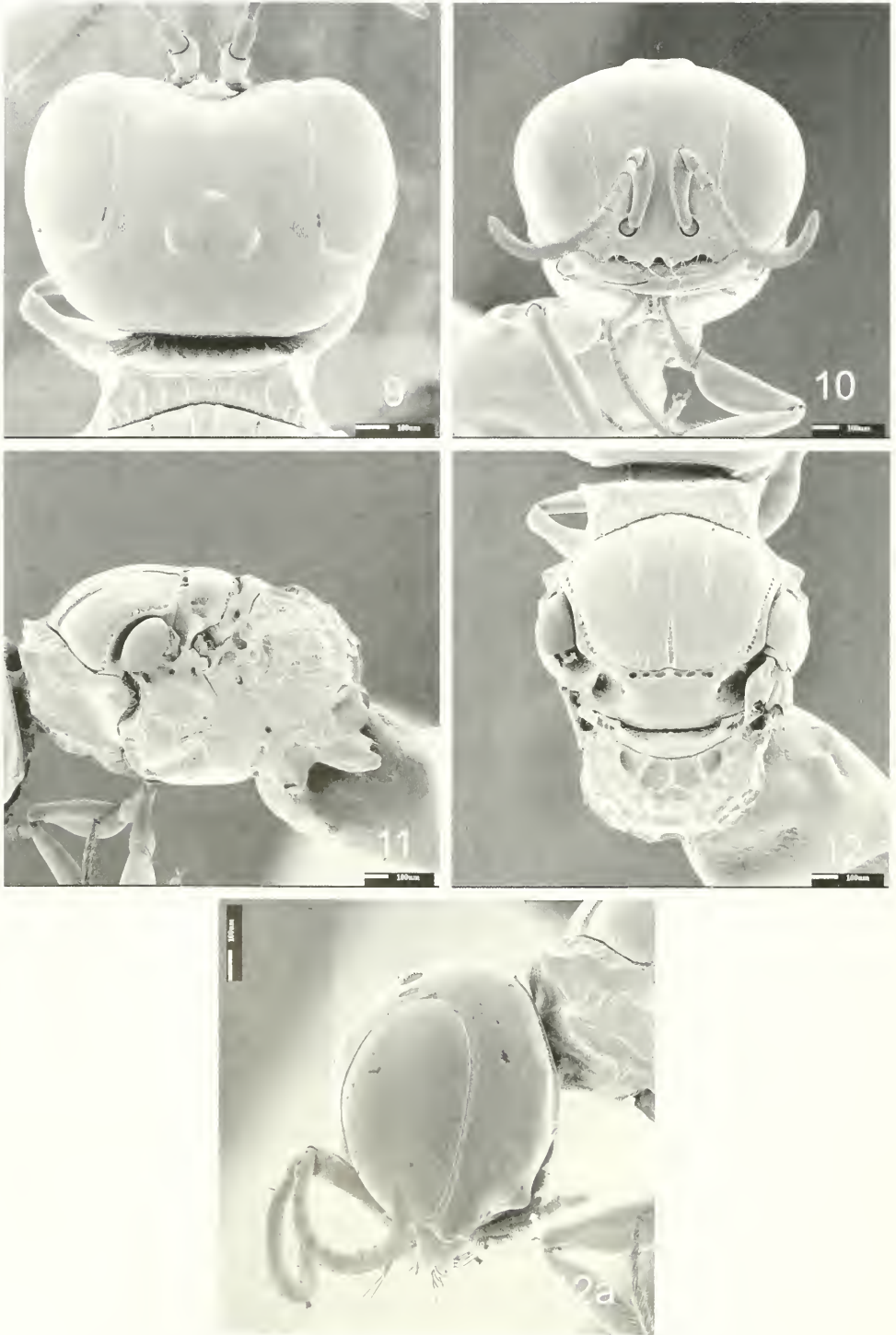

Figs. 9–12. *Incastigmus hexagonalis* ♀. 9, Head, dorsal. 10, Head, frontal. 11, Mesosoma, lateral. 12, Mesosoma, dorsal. 12a, Head, lateral, with arrow indicating genal tooth.

Napo) (1♀ FSCA). Misahualli (1♀ PMAE). Tena (1♀ PMAE). **PERU:** [Chanchamayo] (BMNH). **Colonia:** Junin (BMNH). La Merced, 18 mi NE. Perene, Río Perene (1♀ CASC). **Huanuco:** Tingo María (BMNH). **Junin:** Paratuchali (1♀ PMAE). Satipo (BMNH). **Loreto:** Iquitos, Barillal (1♀ PMAE). **BRAZIL:** [Chapada] (3♀ CMNH). [Corumba] (1♀ CMNH). [Santarem] (1♀ USNM). **Mato Grosso:** 12°50'S 51°47'W (BMNH). Cerrado (BMNH).

7. *Incastigmus ictericornis* Finnamore  
new species

Figs. 13–20

*Derivation of Name.*—The name *ictericornis* is derived from the Greek *ikterikos*, meaning yellowish, and the Latin *cornu*, meaning horn, in reference to the yellowish antenna of this species.

*Diagnosis.*—Females are easily distinguished from other species by the following combination of characters: the median lobe of the clypeus has a subapical semi-circular depression with several long setae, the pronotal lobe is rounded, and the scutal punctures are normal, not striatopunctate. Males are not easily separated from other species, but the following characters will be of some assistance: the flagellum without ventral brush of setae or tyli, and flagellomeres I and X length less than  $2 \times$  apical width, the gena without ventral tooth or swelling, mesosoma black, pronotal lobe rounded, median groove of scutum reaching admedian lines, and tergum I of metasoma shiny, without microsculpture.

*Male.*—Length 4.0–4.5 mm. **HEAD.** Flagellomeres without tyli or specialized setae ventrally; flagellomere I length  $1.6 \times$  apical width; flagellomere X length  $1.3 \times$  apical width; flagellomere XI straight, cylindrical, apex conical; clypeus obscured by dense appressed setae which extend up frons along inner eye margin to half the height of scape; frons microsculptured, punctures obscure; vertex shiny, weakly microsculptured, punctures irregular, 2 or

more diameters apart; gena without ventral tooth or swelling, microsculptured, punctures obscure and scattered; micropore field present as an oval patch between compound eye and ocellus, without depression behind it; lateral ocelli closer to each other than to compound eye; OOD  $1.4 \times$  LOD. **MESOSOMA.** Transverse pronotal carina toothed at humeral angle, and toothed ventrally; transverse pronotal groove longitudinally striate; pronotal lobe rounded, without anterior carina; lateral region of pronotum longitudinally striate. Scutum microsculptured throughout, punctures irregular, 1 or more diameters apart; notauli usually attenuating about scutal midlength, in some specimens notauli reach posterior quarter of scutum; median scutal groove reaching admedian lines. Scutellum microsculptured, with median longitudinal sulcus, and several punctures laterally. Preomalar area anteriorly with sparse setae that do not obscure sculpture. Mesopleuron microsculptured on hypopleural area, shiny with less microsculpture on ventral regions; hypersternaulus, scrobal sulcus, and omaulus coarsely foveolate; mesopleuron microsculptured, with several short longitudinal striae along posterior margin. Propodeum shiny, weakly microsculptured, coarsely areolate over most of its surface, except area adjacent to metapleuron which is shiny, without sculpture; propodeal enclosure not differentiated from lateral spheres. **METASOMA.** First tergum shiny, without microsculpture, succeeding terga with an oily sheen, sparsely punctate with punctures many diameters apart. Sterna similar in sculpture to terga with punctures slightly more dense on posterior sternum and 3 or more diameters apart in lateral regions. **COLOR.** Black. White: mandible, except apex; pronotal lobe. Yellow-brown: palpi; antennae; tegula; fore leg, except coxa and femur; mid leg, except coxa and femur; hind tarsus.

*Female.*—Length 4.0–5.0 mm. Similar to

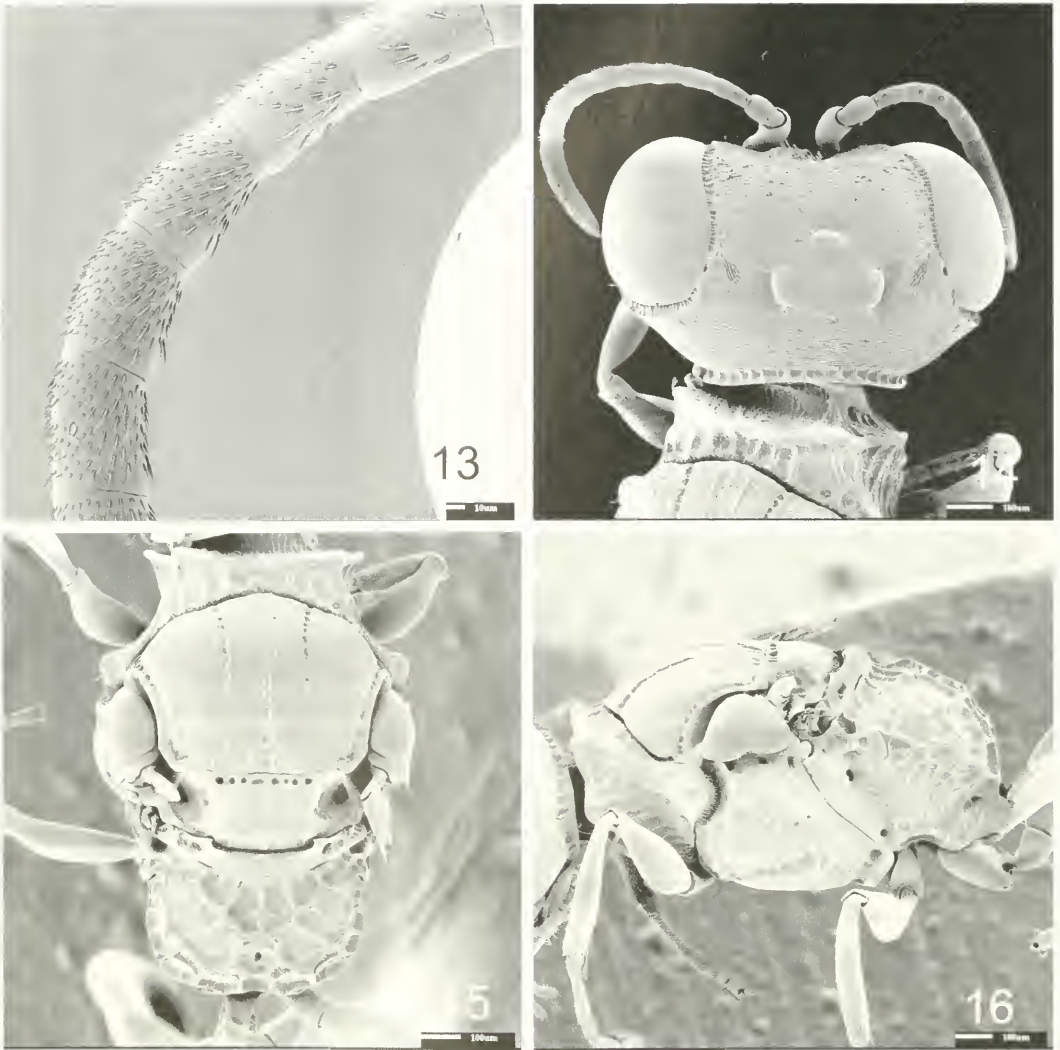

Figs. 13-16. *Incastigmus ictericornis*♂. 13, Mid flagellomeres of antenna. 14, Head, dorsal. 15, Mesosoma, dorsal. 16, Mesosoma, lateral.

male except as follows: flagellomere 1 length  $1.8 \times$  apical width; clypeus shiny, without microsculpture, or with weak microsculpture medially; clypeal punctures 1-3 diameters apart medially; median clypeal lobe with 2 teeth separated by a shallow emargination, long setae arising from subapical semicircular depression. Inner eye margin sparsely setose with sculpture not obscured; OOD  $2.0 \times$  LOD.

*Material Examined*.—28 ♂, 7 ♀. HOLO-

TYPE MALE: Peru: Madre de Dios: Pto. Maldonado 1-11-1-1984 L. Huggert (PMAE). Paratypes: **ARGENTINA**: Salta: Oran, Abra Grande 18-25-X-1968 C. Porter (3♂ MCZC); 18-IV-5-V-1969 C. Porter (1♂ MCZC). **Tucuman**: Horco Molle, nr. Tucuman 15-21-V-1966 L. Stange (1♂ IMLA). **BOLIVIA**: La Paz: Cavinás, Río Beni VII W.M. Mann Mulford Bio. Expl. 1921-22 (1♀ USNM). **BRAZIL**: Amazonas: [Jefte] 7-IX-1904 Ducke (1♂ MPEG). **Bahia**: Itabuna CEPEC XI-1978 F.P. Ben-

ton (2♂ BMNH). **Espirito Santo:** Linhares, XI-1967 F.M. Oliveira (1♂ PMAE). **Minas Gerais:** Aguas Vermelhas 15°45'S 41°28'W 800m XII-1983 Alvarenga (1♂ AEIC). Barbacena 26-X-1905 Ducke (1♂ MPEG). S. Caraca, S Barbara III-1971 F.M. Oliveira (2♀ PMAE). **Río de Janeiro:** Represa Río Grande, Guanabara V-1972 M. Alvarenga (2♂ 1♀ PMA). Río de Janeiro VIII (2♂ USNM). Teresopolis 9-III-1966 H. & M. Townes (1♀ AEIC). **Rondonia:** [Ft.] Príncipe [da Beira?] Río Guapore (1♂ CMNH). **Santa Catarina:** Nova Teutonia, I-1968 F. Plaumann (1♀ MCZC). **São Paulo:** São Paulo (1♂ ZMUM). **ECUADOR:** [Bucay] 1000' 7-X-1922 F.X. Williams (1♂ BPBM). **PARAGUAY:** [no locality] Fiebrig (1♂ HNHM). **Cordillera:** Col. [Colonia] Piareta XII-1971 Pena (2♂ IIES). **PERU:** **Huanuco:** Tingo María 1km E. 2-VIII-1971 2000' P.S.&H.L. Broomfield B.M. 1971-486 (1♀ BMNH). **Madre de Dios:** Pto. Maldonado 1-11-I-1984 L. Hugert (6♂ PMAE).

#### 8. *Incastigmus ignithorax* Finnamore new species

*Derivation of Name.*—The name *ignithorax* is derived from the Latin *ignis* meaning fire and the Greek *thorax*, in reference to the orange-yellow thorax found in members of this species.

*Diagnosis.*—*Incastigmus ignithorax* differs from all others in the genus by the orange-yellow thorax, the short (does not reach scutal midlength) posterior median groove on the scutum; and the quadrilobed clypeal apex. Other species with an extensively light-colored thorax include *pyrrhopyxis* which has a dark propodeum, a bidentate clypeus, and a median groove on the scutum extending to the admedian lines, *thoracicus* which lacks a median groove on the scutum, and *hexagonalis* which has a tooth-like projection on the lower gena.

*Male.*—Unknown.

*Female.*—Length 5 mm. HEAD. Flagellomere 1 length 2 × maximum width.

Clypeus shiny, without appressed setae, sparsely punctate, sparsely setose; clypeal apex with 4 teeth, median teeth more strongly developed than lateral teeth; the base of each median tooth bears a pit from which arises a long seta. Head microsculptured but not uniformly, scapal basin more densely microsculptured than vertex; punctures sparse, more or less regular and separated by over 5 puncture diameters. Micropore field present as an oval patch between hind ocellus and compound eye. Gena shiny, obscurely microsculptured, with slight ventral swelling, sparsely and regularly punctate. OOD 2.6 × LOD. MESOSOMA. Transverse pronotal carina toothed at humeral angle and toothed ventrally; transverse pronotal groove with several longitudinal striae; pronotal lobe carinate, appearing somewhat toothed; pronotum laterally with several longitudinal striae. Scutum shiny, weakly microsculptured; notauli developed anteriorly, not reaching scutal midlength; median scutal groove short, restricted to posterior scutum, not reaching midlength and not reaching admedian lines; ridges along posterior margin of scutum occasionally reaching midlength; scutal punctures relatively strong, better developed on lateral areas, separated by 3 or 4 puncture diameters. Scutellum shiny, with weak microsculpture, several punctures present laterally. Mesopleuron shiny, without microsculpture; punctures sparse, several present on the sternopleural region. Preaular area anteriorly with sparse setae that do not obscure sculpture beneath. Hypersternaulus, scrobal sulcus, and omaulus coarsely foveolate. Metapleuron microsculptured, dull, impunctate. Propodeum shiny, coarsely areolate throughout; area adjacent to metapleuron microstriate; propodeal enclosure not differentiated from lateral spheres. METASOMA. Terga shiny, without microsculpture; punctures sparse, obscure. Sterna shiny; punctures sparse on anterior sterna, relatively dense

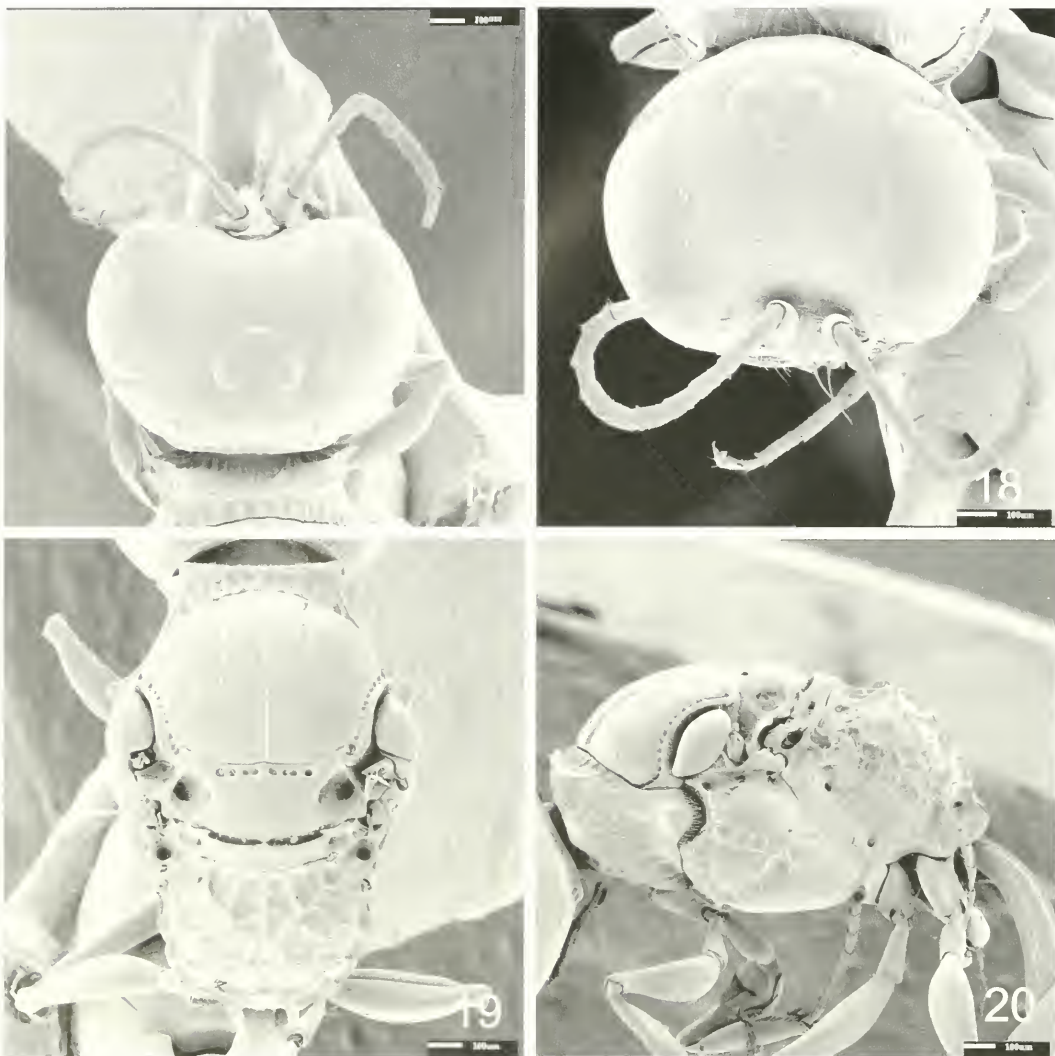

Figs. 17–20. *Incastigmus ictericornis* ♀. 17, Head, dorsal. 18, Face, oblique dorsal. 19, Mesosoma, dorsal. 20, Mesosoma, lateral.

on more posterior sterna where they are 1 to 2 puncture diameters apart. **COLOR.** Black. Orange-yellow: mandible, except apex; antenna; palpi; mesosoma, except posterior of mesosternum and metasternum; legs, except outer surface of hind tibia; metasoma occasionally on dorsal petiole and apical sterna.

**Material Examined.**—5 ♀. **HOLOTYPE FEMALE:** Panama Prov. 6km N. Capira (Cerro Campana) 8-IV-1981 R.W. Brooks (SEM). **Paratypes:** **COSTA RICA:** **Heredia:** F. La

Selva 3 km S. Pto. Viejo 10°26'N 84°01'W, 3-VII-1986 H.A. Hespentheide (1♀ PMAE). **PANAMA:** **Canal Zone:** Barro Colorado 24-VII-1924 N. Banks (1♀ MCZC). **Panama:** 6km N. Capira (Cerro Campana) 8-IV-1981 R.W. Brooks (2♀ SEMC).

#### 9. *Incastigmus inti* Finnamore Figs. 21–28

*Incastigmus inti* Finnamore 1995: 235. Holotype, male PMAE. Ecuador: Napo Prov.: Tena 15-II-1986 A.T. Finnamore sweep; examined.

*Diagnosis.*—The following combination of characters will separate this species from all others in the genus: Micropore field of vertex oval; scutum with median groove and notauli complete from anterior to posterior margins, without regular longitudinal ridges between grooves; pronotal lobe white, rounded and conical; male antenna with tylus on flagellomere XI; female clypeus with 2 elongate setae arising from 2 narrowly separated subapical pits on median clypeal lobe; female upper frons shiny, without microsculpture anterolaterally to mid ocellus.

*Male.*—Length 2.5–4.0 mm. HEAD. Flagellomeres without specialized setae; flagellomeres II to XI with tyli, that on flagellomere XI imparting an asymmetrical shape, apex conical; flagellomere I length  $2.2 \times$  apical width; flagellomere X length  $1.4 \times$  apical width. Head microsculptured on frons, vertex shiny; punctures sparse; clypeus obscured by dense appressed setae which extend up frons along inner eye margin little more than height of antennal socket; gena microsculptured, sparsely punctate, not carinate, without ventral tooth or swelling; micropore field present as an oval patch between compound eye and lateral ocellus; without depression behind it; lateral ocelli closer to each other than to compound eyes; OOD  $1.7 \times$  LOD. MESOSOMA. Transverse pronotal carina toothed laterally and toothed ventrally; transverse pronotal groove longitudinally striate; pronotal lobe conical, apex rounded, without anterior carina; lateral area of pronotum with longitudinal striae. Scutum variable, entirely microsculptured to weakly microsculptured with shiny patches; notauli complete to posterior margin; median scutal groove complete to anterior margin; punctures sparse. Scutellum microsculptured, with several punctures on lateral region near midlength. Preomaular area with sparse setae that do not obscure underlying sculpture. Mesopleuron variable, from entirely microsculptured to weakly shiny with reduced microsculp-

ture, sparsely punctate to impunctate. Hypersternaulus, omaulus, and scrobal sulcus foveolate. Metapleuron usually microsculptured with several short, weak, longitudinal striae on posterior margin. Propodeum shiny, generally without microsculpture, coarsely areolate throughout, except shiny, unsculptured area adjacent to metapleuron; propodeal enclosure not differentiated from lateral spheres. METASOMA. First tergum shiny, without microsculpture, punctures minute and obscure; sterna weakly microsculptured, punctures sparse and many diameters apart on sternum II; punctures increasing in density to sternum VI where minute punctures near lateral midlength are about 1 diameter apart. COLOR. Black. White: mandible, except apex; pronotal lobe. Yellow-brown: palpi; mandible subapically; antenna; tegula; fore leg, except coxa; mid leg, except coxa; hind trochanter and tarsus; metasomal sternum VIII.

*Female.*—Length 3.0–4.25 mm. Similar to male except as follows: antenna without tyli, flagellomere X length  $1.25 \times$  apical width; clypeus shiny, without microsculpture, sparsely punctate but occasionally moderately dense punctures grouped in median area; median clypeal lobe with 2 long setae arising from 2 narrowly separated, subapical pits; apex of clypeal lobe truncate, without teeth. Scutum with several irregular ridges between notauli and median grooves; color as above, but variable to dark antennal flagellum and dark femora.

*Material Examined.*—258 ♂, 109 ♀. **BOLIVIA:** [Las Juntas] (1 ♀ CMNH). La Paz: Chulumani 1,700m (2 ♂ 5 ♀ BMNH). Coroico-Chulumani (1 ♀ MCZC). Coroico, Sta. Barbara 1,100m (1 ♀ PMAE). Tumpasa (1 ♂ USNM). Yungas, 13km S. Caranavi 850m (2 ♀ PMAE). **BRAZIL:** Mato Grosso: Itaum (3 ♀ AEIC). Para: Belem IPEAN (1 ♀ CNCI). **COLOMBIA:** Caqueta: Florencia 480m (1 ♀ BMNH). Yuruyaco, 73km SW. Florencia (2 ♂ 1 ♀ BMNH).

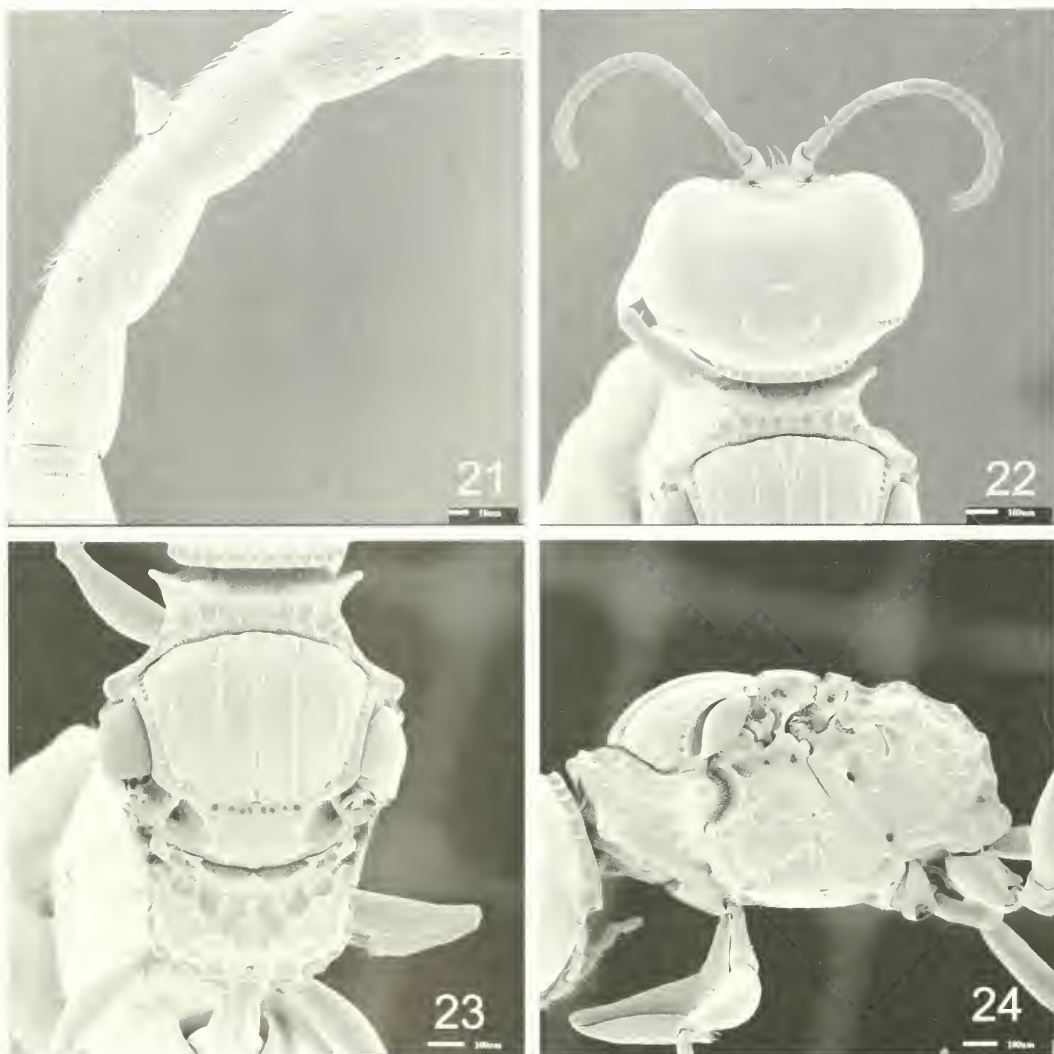

Figs. 21–24. *Incastigmus inti* ♂. 21, Mid flagellomeres of antenna. 22, Head, dorsal. 23, Mesosoma, dorsal. 24, Mesosoma, lateral.

**Putumayo:** Mocoa (10♂ 8♀ BMNH). Villa Garzon, 8mi S. Mocoa (1♂ BMNH). **Vaupés:** Mitu (1♂ BMNH). **ECUADOR:** [Mera] (1♂ BPBM). **Carchi:** Chical 1,250m (1♀ CMNH). **Napo:** Coca (1♂ AEIC). Coca & Napo Rivers (1♂ AEIC). Limoncocha, 250m (2♂ 2♀ CNCI). Puerto Misahualli (26♂ 5♀ PMAE). Muyuna, 5km W. Tena (1♀ BMNH). Santa Cecilia (1♂ USNM). Tena (1♂ BMNH, 1♀ CNCI, 18♂ 8♀ PMAE). Tena-Puyo Hwy (1♂ PMAE). **Pastaza:** Puyo 960m (15♂ BPBM). Puyo,

22km SW. (1♂ 1♀ CNCI). Puyo, 23km SE. (1♀ USNM). Puyo, 44km S. (5♂ 2♀ USNM). Puyo, 18km N. (1♂ RNHM). **Pichincha:** Tinalandia 800m (2♂ PMAE). **Zamora-Chinchipe:** Cumbaratza (1♂ AEIC). Río Jumboe (5♂ 2♀ MCZC). Zamora (1♂ AEIC). **PARAGUAY:** **Cordillera:** Piareta (1♂ IIES). **Guaira:** W. Villarica, Caballero (1♂ IIES). **PERU:** **Cuzco:** Agua Calliente (8♂ 1♀ PMAE). Machu Picchu (1♀ AEIC); Quincemil, 750m near Marcapata (8♂ 3♀ AEIC). **Huanuco:** Ca-

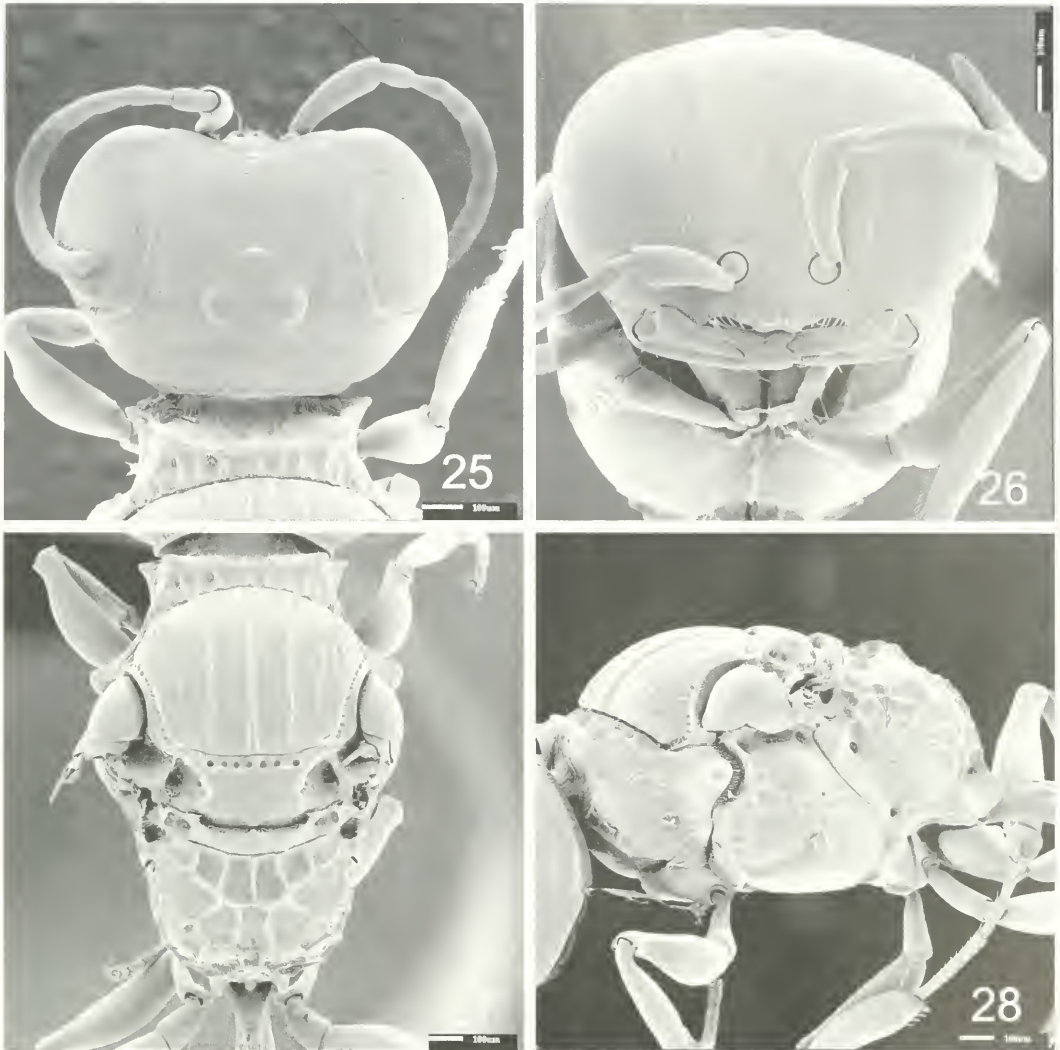

Figs. 25–28. *Incastigmus inti* ♀. 25, Head, dorsal. 26, Face. 27, Mesosoma, dorsal. 28, Mesosoma, lateral.

yumba, 35km S. Tingo María 800m (1♀ BMNH). Las Palmas, 5mi SW. 1,000m (2♂ CASC). Las Palmas 10mi SW. 1,000m (4♀ CASC). Monson Valley, Tingo María (13♂ 10♀ CASC). Tingo María (1♀ BMNH, 20♂ 4♀ PMAE). Tingo María 26mi E. 1,100m (1♀ CASC). Tingo María, 67 mi E. (1♀ CASC). Tocache (4♂ 1♀ PMAE). **Junin:** Colonia Perene, Río Perene 18mi NE. La Merced (2♂ 1♀ CASC). Paratuchali (10♂ 4♀ PMAE). Satipo (21♂ 7♀ PMAE). **Lima:** Magdalena [del Mar?] [Lima?] (1♀ USNM). **Loreto:** Iquitos, NE.

Río Nanay (10♂ PMAE). Iquitos, Gransa (2♂ PMAE). Iquitos, Quisto Cocha (1♂ PMAE). Iquitos, Barilla (1♂ PMAE). **Madre de Dios:** [Laberinto] 70km W. Puerto Maldonado on Río Madre de Dios (1♀ PMAE). Puerto Maldonado (50♂ 14♀ PMAE); Tambopata Reserve 50km S. Puerto Maldonado on Río Tambopata (1♂ 1♀ PMAE). Ucayali: [Tacshitea] 88km N. Pulcalpa jet Río Callaria & Río Ucayali (1♂ PMAE). **VENEZUELA:** **Zulia:** El Tucuco, 45km SW. Machiques (1♀ USNM).

10. *Incastigmus iplis* Finnamore  
 new species  
 Figs. 29–36

*Derivation of Name.*—*Iplis* is a Greek term referring to a Cretian girl who was changed to a man, in reference to the difficulty encountered in associating the females with the males of this species.

*Diagnosis.*—Males and females of this species can be distinguished by the following characters: flagellomeres without setal brush, apical flagellomere unmodified, micropore field round, microsculpture of vertex continuous with that of frons, mesosoma black, pronotal lobes white and rounded, notauli and median scutal grooves complete.

*Male.*—Length 3.5–4.5 mm. HEAD. Flagellomeres ventrally without specialized setae; tyli present on flagellomeres I through VI or VII; tyli appear as a yellow fold on the ventral surface; flagellomere XI symmetrical, cylindrical, apex conical; flagellomere I length  $1.5 \times$  apical width; flagellomere X length  $1.5 \times$  apical width. Clypeus obscured by dense appressed setae which extend up frons along inner margin of eyes to about half length of scape; microsculpture of frons continuous with that of vertex, punctures of frons sparse, more or less regular, 3 or more diameters apart; oval micropore field present between compound eye and lateral ocellus, without depression behind it; gena microsculptured, sparsely punctate, shiny ventrally, without tooth or swelling in ventral region; OOD  $1.8 \times$  LOD. MESOSOMA. Transverse pronotal carina toothed at humeral angle and toothed ventrally; transverse pronotal groove with coarse longitudinal striae; pronotal lobe roundly conical, without anterior carina. Scutum microsculptured, more or less shiny posteriorly; punctures sparse, small, scattered between irregular grooves and ridges of surface; notauli complete to posterior margin of scutum; median scutal groove contiguous with admedian lines.

Scutellum microsculptured with several lateral punctures and a poorly defined median sulcus. Preomalar area anteriorly with sparse setae, sculpture visible; mesopleuron entirely microsculptured; hypersternaulus, scrobal sulcus, and omalulus coarsely foveolate; metapleuron microsculptured, with several short longitudinal striae along posterior margin. Propodeum with weak microsculpture, coarsely areolate, except small shiny region near metapleuron; propodeal enclosure not differentiated from lateral spheres. METASOMA. Tergum I shiny with minute, obscure punctures; succeeding terga with an oily sheen, punctures minute, obscure; sterna with an oily sheen, punctures slightly increasing in density on more posterior sterna; sternum VI with a narrow median longitudinal impunctate area, punctures about 1 to 2 diameters apart immediately lateral to this area. COLOR. Black. White: pronotal lobe. Yellow-brown: palpi; mandible, except apex; antenna ventrally, and dorsally to flagellomeres IV or V; tegula; fore leg, except coxa and femur dorsally; mid leg, except coxa and femur; hind trochanter and hind tarsus.

*Female.*—Length 3.5–5 mm. Similar to male except as follows: flagellomere I length  $1.7 \times$  apical width; clypeus shiny, sparsely punctate, punctures over 3 diameters apart in median clypeal area; median clypeal lobe truncate, without teeth; long setae arising from pair of subapical pits; frons along inner margin of eye with sparse setae that do not obscure sculpture; color as in male except hind tibia yellow-brown dorsally.

*Material Examined.*—54 ♂, 55 ♀. HOLOTYPE MALE: Brazil: Bahia, Itabuna, CEPEC 23-XI-1983 F.P. Benton (BMNH). Paratypes: **BOLIVIA: La Paz:** Chulumani 1,700m 27-III-1979 M. Cooper B.M.1979-216 (1 ♀ BMNH). **BRAZIL: Bahia:** Itabuna, CEPEC: (various dates) 1982–1984 F.P. Benton (33♂ 45♀ BMNH). **Goias:** Jataí XI-

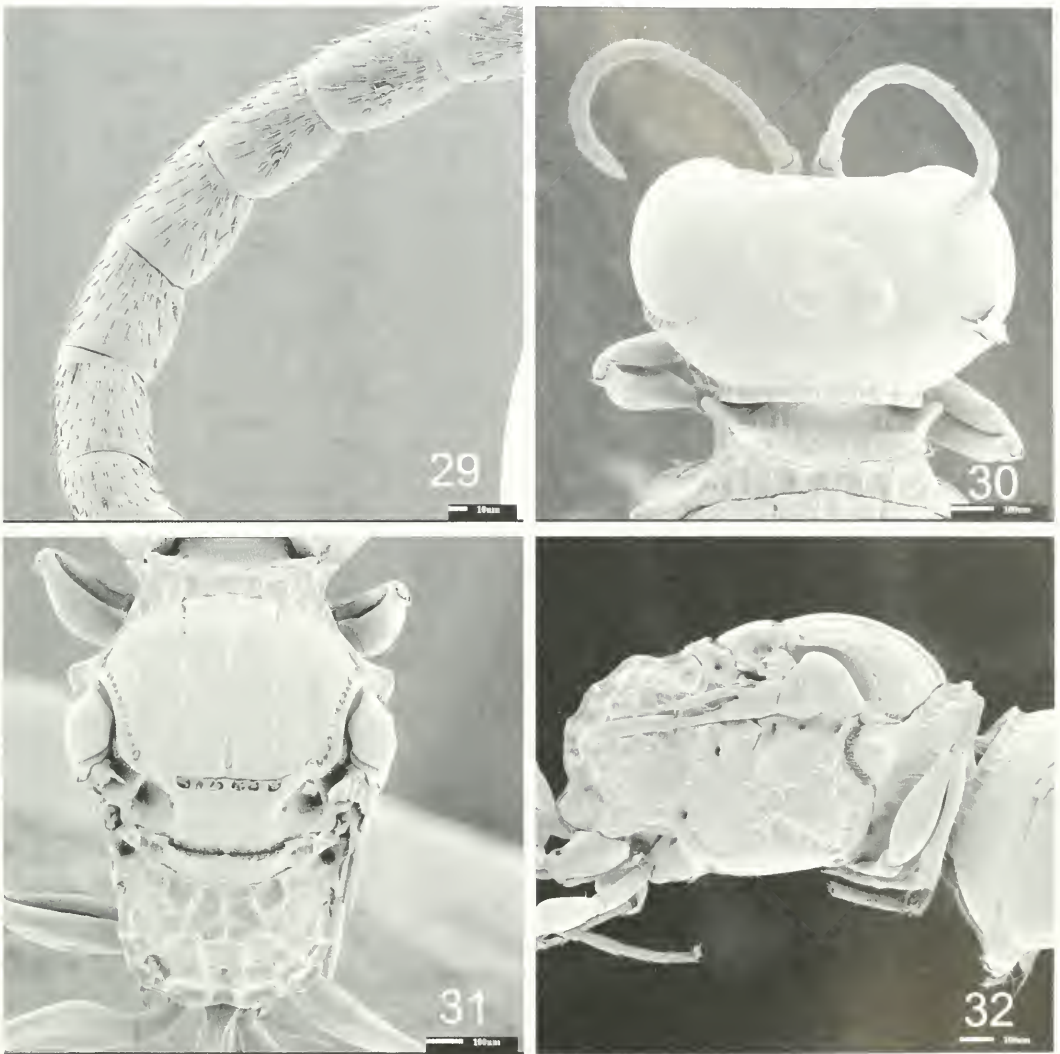

Figs. 29–32. *Incastignus iphis* ♂. 29, Mid flagellomeres of antenna. 30, Head, dorsal. 31, Mesosoma, dorsal. 32, Mesosoma, lateral.

1972 F.M. Oliveira (1♂ 1♀ CNCI). **Mato Grosso:** Itaum Dourados III-1974 M. Alvarenga (3♂ AEIC, 3♂ 1♀ CNCI, 2♂ PMAE). **Río de Janeiro:** Repressa Río Grande, Guanabara VII-1972 M. Alvarenga (1♂ CNCI). **São Paulo:** São Paulo, [Rua?] Teodora Sampaio: XI-1977 M. Alvarenga (1♂ AEIC, 1♀ IIES); XII-1977 M. Alvarenga (2♂ CNCI); VIII-1975 Oliveira (1♀ PMAE). Sao Vicente 30-X-1961 N.L.H. Krauss (1♂ USNM). **PARAGUAY:** Can-

indeyu: SW. Salto del Guaira 8-XII-1971 (1♀ CNCI). **Cordillera:** [Colonia] Pirareta XII-1971 Pena (3♂ IIES). **Guaira:** W. Villarrica Caballero I-1972 Pena (1♂ 2♀ IIES). **San Pedro:** Río Ypane Corroero XII-1983 M.A. Fritz (1♂ IIES). **PERU:** **Cuzco:** Quilabamba 1700m 23-27-XII-1983 A.T. Finnamore (1♀ PMAE). Quincemil, 750m near Marcapata IX-1962 Luis Pena (1♂ AEIC). **Loreto:** Iquitos, Quisto Cocha 5-II-1984 L. Huggert (1♀ PMAE).

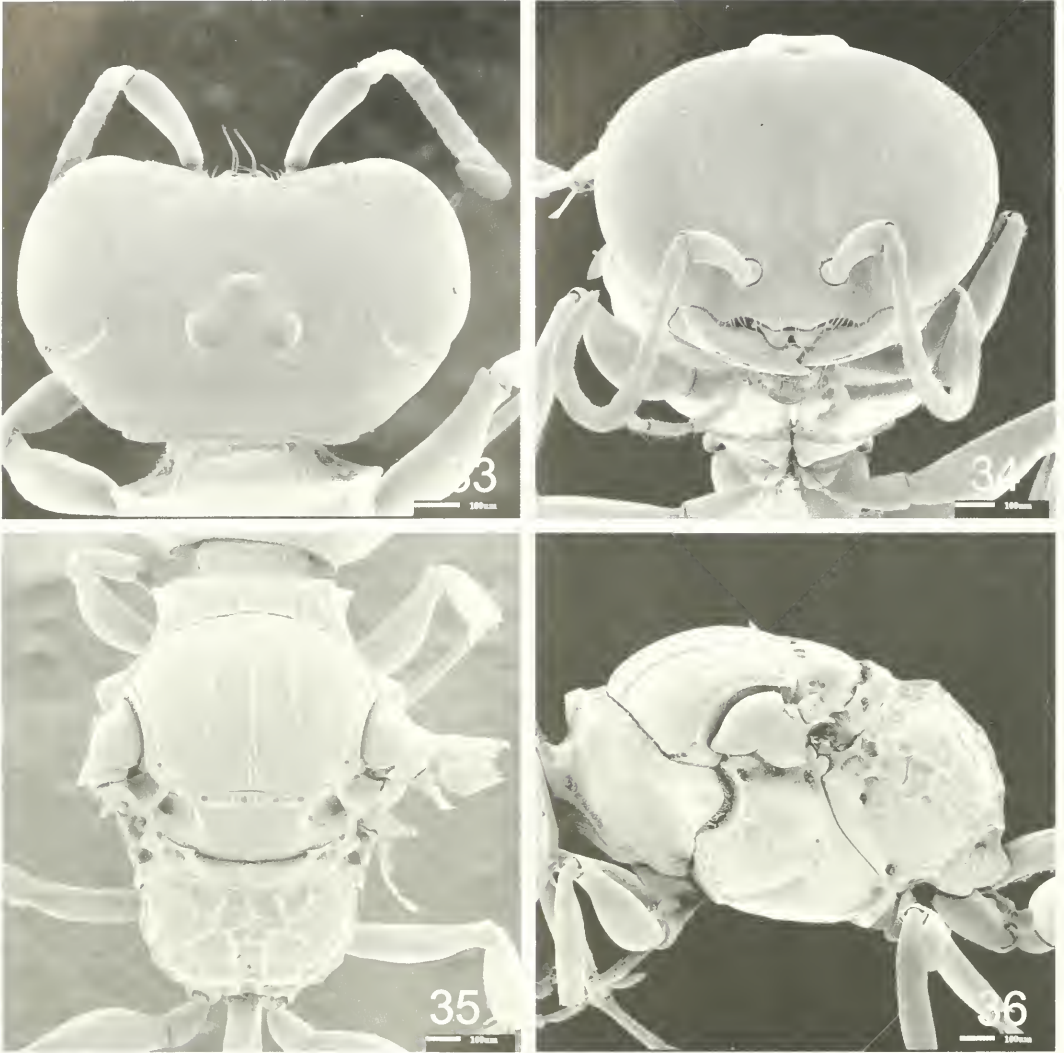

Figs. 33–36. *Icastigmus iphis* ♀. 33, Head, dorsal. 34, Face. 35, Mesosoma, dorsal. 36, Mesosoma, lateral.

11. *Icastigmus kunkopteryx* Finnamore  
new species

Figs. 37–40

*Derivation of Name.*—The name *kunkopteryx* is derived from the Quichuan *kunka*, meaning collar; and the Greek *pteryx*, meaning wing, referring to the flattened, wing-like tooth on the pronotal lobe of this species.

*Diagnosis.*—Both males and females of this species can be recognized by the flattened, wing-like, tooth on the pronotal lobe in most specimens, the complete me-

dian scutal groove, and the oval micro-pore field on the vertex. This species is unusually variable and probably represents a complex of several species, but an insufficient number of specimens exist to resolve the question of variation.

*Male.*—Length 4 mm. HEAD. Flagellomeres ventrally with a narrow longitudinal asetose region; obscure tyli present on flagellomeres III to VI or VIII; flagellomere I length  $1.8 \times$  apical width; flagellomere X length  $1.8 \times$  apical width; flagellomere XI straight, cylindrical, apex conical. Clypeus

obscured by dense appressed setae which extend up frons along inner margin of eyes to about half the height of scape; frons microsculptured; vertex usually shiny, sometimes microsculptured and not well distinguished from frons; punctures on vertex sparse, irregular, 3 or more diameters apart; gena microsculptured, obscurely punctate, without ventral tooth or swelling; some specimens with irregular longitudinal microstriae arising from occipital carina that extend to compound eye; micropore field present as an oval patch between compound eye and ocellus; without depression behind it; lateral ocelli closer to each other than to compound eyes; OOD  $1.8 \times$  LOD. **MESOSOMA.** Transverse pronotal carina tooth-like at humeral angle, sometimes sharply toothed, and ventrally toothed; transverse pronotal groove longitudinally striate; pronotal lobe somewhat flattened dorsally, often flattened ventrally; anterior carina on pronotal lobe continuous to apex and often continued posteriorly; pronotal lobe in several specimens conical, produced, and sharply pointed; lateral area of pronotum longitudinally striate. Scutum in most specimens microsculptured on anterior half, shiny without microsculpture on posterior half; some specimens microsculptured throughout; in most specimens scutum irregularly ridged or striatopunctate; several specimens without scutal striae; scutal punctures sparse, irregular, a few to many diameters apart; notauli extending to posterior margin of scutum or attenuating on posterior half; median scutal groove extending to and between admedian lines. Scutellum microsculptured with several punctures laterally, and median longitudinal sulcus absent or poorly developed. Preomaular area anteriorly with sparse setae that do not obscure sculpture. Mesopleuron shiny, often with weak microsculpture dorsally; posterior half microstriate; hypersternaulus, scrobal sulcus, and omaulus foveolate. Metapleuron microsculptured, several short longi-

tudinal striae along border with propodeum. Propodeum shiny, weakly microsculptured, coarsely areolate over most of surface except small shiny area adjacent to metapleuron; propodeal enclosure not differentiated from lateral spheres. **METASOMA.** First tergum shiny, without microsculpture; succeeding terga with an oily sheen, punctures minute, sparse and obscure; sterna similar to terga, punctures generally more evident; sternal punctures reaching maximum density on sternum V where they are about 1 to 2 diameters apart. **COLOR.** Black. White: usually mandible, except apex; pronotal lobe. Yellow-brown: palpi; sometimes mandible, except apex; scape; pedicel; basal flagellomeres; tegula; fore leg, except coxa and femur; mid leg, except coxa and femur; hind trochanter and hind tarsus.

*Female.*—Length 4.0–4.5mm. Females exhibit less variation than males and are most similar to those males with a shiny posterior half of the scutum that is irregularly ridged to striatopunctate. The following description of the female is from the Holotype, but applies to most specimens. Similar to male (as noted above) except as follows: flagellomere I length  $2.0 \times$  apical width; clypeus shiny, punctures sparse about 1 to 3 diameters apart medially; median clypeal lobe truncate, with a slight emargination, not toothed, and 2 long setae arising from a subapical semicircular depression; frons along inner eye margin with sparse setae that do not obscure sculpture; gena shiny on anterior half; OOD  $1.6 \times$  LOD; color as above except yellow-brown on entire fore leg, entire mid leg, and hind leg, except tibial apex and dorsum of femur.

*Material Examined.*—5 ♂, 16 ♀. **HOLOTYPE FEMALE:** Peru: Loreto, Iquitos NE. Río Nanay 6-II-1984 L. Huggert (PMAE). Paratypes: **BOLIVIA:** El Beni: [Rurenbacque] 270m 18-IV-1979 M. Cooper B.M. 1979-216 (1 ♀ BMNH). **BRAZIL: Amazonas:** Río Javari, Estirao do Equador X-1973 Alvarenga (2 ♀ IIES). **COLOMBIA: Ama-**

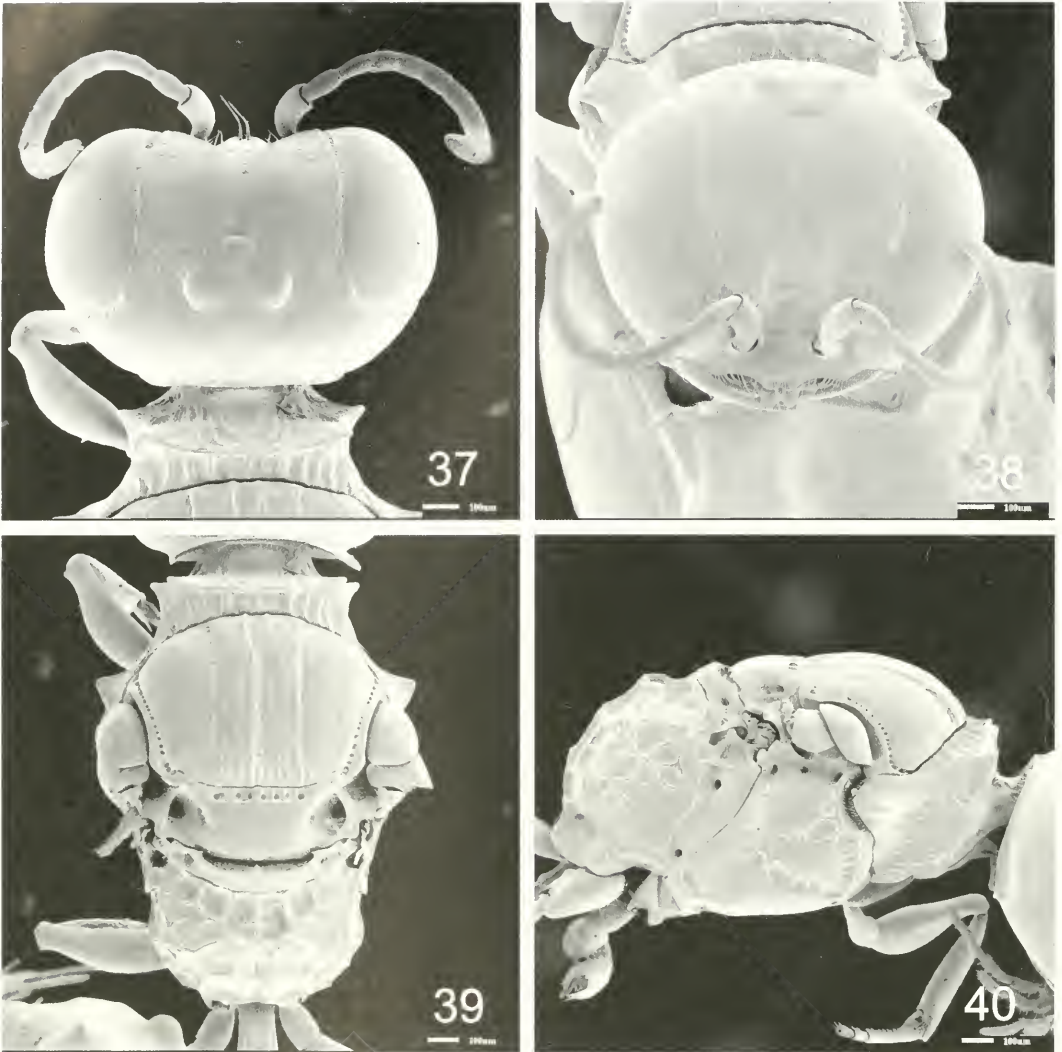

Figs. 37-40. *Incastigmus kunkopteryx* ♀. 37, Head, dorsal. 38, Face. 39, Mesosoma, dorsal. 40, Mesosoma, lateral.

**zonas:** La Chorrera 14-23-VIII-1976 M. Cooper B.M. 1976-727 (1 ♀ BMNH). Leticia 21-23-VIII-1974 M. Cooper B.M. 1974-503 (1 ♀ BMNH). **Meta:** 3 mi w Villavencio 920m 11-III-1955 E.I. Schlinger & E.S. Ross (1 ♀ CASC). **Putumayo:** Villa Garzon, 8mi S. Mocoa 30-VII-1978 M. Cooper B.M. 1978-431 (1 ♀ BMNH). Mocoa 28-VII-1978 M. Cooper B.M. 1978-431 (1 ♀ BMNH); Mocoa 7-VIII-1978 M. Cooper B.M. 1978-431 (1 ♀ BMNH). **ECUADOR:** **Morona-Santiago:** Cord. Cutucu c. 6km E. Macas

c. 1000m 21-X-1978 M. Cooper B.M. 1979-20 (1 ♂ BMNH). **Napo:** Misahualli, Río Napo 19-II-1983 L. Huggert (1 ♀ PMAE). Limoncocha 250m 15-28-VI-1976 S. & J. Peck (1 ♀ CNCI). Laguna Jatuncocha 20km S. Nuevo Rocafuerte on Río Yasuni 8-9-II-1986 Finnamore, Thormin Mt. (1 ♀ PMAE). **Pastaza,** 27km N. Puyo 18-VIII-1989 L. Stange & R. Miller (1 ♂ FSCA). 22km SW. Puyo 200m 14-16-VII-1976 S. & J. Peck forest (1 ♀ CNCI). Puyo 960m 1-8-X-1970 J. & M. Sedlacek (1 ♀ BPBM).

**PERU:** [Chanchamayo] 24-V-1949 J.M. Schunke B.M. 1950–559 (2♂ BMNH). **Cuzco:** Machu Picchu 1900m 4-19-IX-1964 C.C. Porter (1♂ MCZC). **Huanuco:** 26mi E. Tin-go María 10-XII-1954 1100m E.I. Schlinger & E.S. Ross (1♀ CASC).

## 12. *Iucastigmus mauracis* Finnamore new species

*Derivation of Name.*—*Mauracis* is derived from the Greek words, *mauros*, meaning black, and *akis*, meaning thorn, in reference to the dark tooth on the pronotal lobe.

*Diagnosis.*—Males of *mauracis* are easily recognized by a semicircular depression posterior to the micropore field, the depression is defined posteriorly by a weakly carinate rim. Females have a black, toothed, pronotal lobe, incomplete notauli and median scutal grooves, obtuse lateral clypeal teeth, and median clypeal teeth often separated by U-shaped emargination. This species is similar to *chincha* from which it is separated by the semicircular depression behind the micropore field in males, and the obtuse lateral clypeal teeth in the female. Female *chincha* have acute lateral clypeal teeth and the median clypeal teeth are combined into a single narrow lobe.

*Male.*—Length 4.0–5.0 mm. **HEAD.** Flagellomeres without specialized setae; flagellomeres II to VII depressed basally, with a broad shiny tylus on apical half. Flagellomere I length  $1.5 \times$  apical width; flagellomere X length  $2 \times$  apical width; flagellomere XI slightly curved, cylindrical, apex conical. Clypeus obscured by dense appressed setae which extend up frons along inner margin of eyes to about half height of scape. Frons microsculptured, punctures not evident; vertex shiny, weakly microsculptured, punctures generally sparse and about 3 diameters or more apart. Micropore field present as an oval patch between compound eye and lateral ocellus, behind it a semicircular or elliptical depression with a weakly cari-

nate posterior rim. Gena shiny, weakly microsculptured, sparsely punctate, without ventral tooth or swelling. Lateral ocelli closer to each other than to eyes; OOD  $1.8 \times$  LOD. **MESOSOMA.** Transverse pronotal carina with acute lateral tooth, and acute ventral tooth; transverse pronotal groove longitudinally striate; pronotal lobe with anterior carina terminating in an acute tooth; lateral area of pronotum longitudinally striate. Scutum microsculptured, with sparse punctures three more diameters apart; notauli present anteriorly, attenuated posteriorly near scutal midlength; median scutal groove present posteriorly, attenuated near scutal midlength and not reaching admedian lines; posterior margin of scutum with several short longitudinal striae parallel to median scutal groove. Scutellum microsculptured, punctures obscure. Preomalar area with sculpture visible beneath sparse setae. Mesopleuron shiny, without microsculpture above hypersternaulus, punctures not evident or sparse; hypersternaulus, scrobal sulcus, and omaulus coarsely foveolate. Metapleuron with microsculpture and several weak longitudinal striae. Propodeum shiny, coarsely areolate, except area adjacent to metapleuron which is longitudinally striate; propodeal enclosure not differentiated from lateral spheres. **META-SOMA.** Terga shiny, those beyond first tergum with oily sheen, punctures minute, sparse, often not evident. Sterna shiny, microsculpture weak, punctures sparse on anterior sterna but increasing in density on more posterior sterna. **COLOR.** Black. Yellow-white to yellow-brown: palpi; mandibles, except apex; scape; pedicel; flagellomeres I to IV; tegula; fore leg, except coxa; mid leg, except coxa; and hind tarsus.

*Female.*—Length 5.0–6.0 mm. Similar to male except as follows: flagellomere I length  $2 \times$  apical width; clypeus shiny, without microsculpture, punctures sparse, 4 diameters apart medially; median clypeal lobe consisting of 2 weakly separated

teeth, bounded laterally by a smaller, less well developed, obtuse lateral clypeal tooth; teeth of median clypeal lobe each with a subapical circular pit from which arises several long setae; sculpture on frons along inner margin of eye not obscured by dense appressed setae. OOD  $2.5 \times$  LOD. Color as in male, but more orange-red, pronotal lobe yellow-brown, and apex of hind coxa, hind trochanter, and hind tibia orange-red.

*Material Examined*.—8 ♂, 32 ♀. HOLOTYPE MALE: Bolivia: La Paz, Chulumani 1700m 31-III-1979 M. Cooper B.M. 1979-216 (BMNH). Paratypes: **BOLIVIA**: El Beni: [Rurrenabaque], Río Beni X-1921-22 W. M. Mann. Mulford Biol. Expl (1♂ USNM). **La Paz**: Chulumani 1700m: 19-25-XII-1955 L.E. Pena (1♂ SEMC); 27-III-1979 M. Cooper B.M. 1979-216 (1♂ 1♀ BMNH); 2-IV-1979 M. Cooper B.M. 1979-216 (4♀ BMNH); 3-IV-1979 M. Cooper B.M. 1979-216 (1♂ 13♀ BMNH). **BRAZIL**: **Permambuco**: Caruaru, V-1972 J. Lima (1♂ PMAE). **ECUADOR**: **Napo-Pastaza**, Mera 6-8mi W. 1500m 10-II-1955 E.I. Schlinger & E.S. Ross (1♀ CASC). **Pastaza**: Mera 26-I-1923 F.X. Williams (1♂ BPBM). **PERU**: [Chanchamayo] 26-III-1949 J.M. Schunke B.M. 1950-559 (2♀ BMNH). **Cuzco**: Machu Picchu: 29-XI-1965 H. & M. Townes (1♀ AEIC); 2-XII-1965 H. & M. Townes (1♂ 1♀ AEIC); 24-27-II-1968 A. Garcia & C. Porter (1♀ MCZC). Machu Picchu museum 1,385m 11-14-VIII-1971 C.&M. Varady B.M. 1971-533 (8♀ BMNH).

### 13. *Incastignius mystaxalbus* Finnamore new species

Figs. 4I-48

*Derivation of Name*.—The name is derived from the Greek *mystax*, meaning upper lip, and the Latin *albus*, meaning white, in reference to the white apical margin of the clypeus in the females of this species.

*Diagnosis*.—All females and some males of this species can be immediately recognized by the white apical margin of the

clypeus. Males can be distinguished by the combination of the median scutal groove reduced to an elongate posterior pit, the pronotal lobes white and rounded, and the mesosoma otherwise black.

*Male*.—Length 3.0-5.0 mm. HEAD. Flagellum without tyli or brush of specialized setae; flagellomere I length  $1.8 \times$  maximum width; flagellomere X length  $1.3 \times$  maximum width; flagellomere XI straight, cylindrical, apex conical. Sculpture of clypeus obscured by dense appressed setae which do not extend up frons along inner eye margin beyond height of antennal socket. Head microsculptured, but not uniformly; scapal basin and vertex distinguished from each other by density of microsculpture. Vertex more or less uniformly punctate with punctures 3 or more diameters apart. Micropore field present as an oval patch between lateral ocellus and compound eye, without depression behind it; gena microsculptured dorsally, shiny ventrally, nonstriate, without ventral swelling or tooth; genal punctures obscure dorsally, 3 or more diameters apart ventrally. Lateral ocelli closer to each other than to compound eye. OOD  $1.3 \times$  LOD. MESOSOMA. Transverse pronotal carina not toothed, angular at humeral angle and ventrally; transverse pronotal groove longitudinally striate; pronotal lobe unmodified, rounded. Pronotum laterally with longitudinal striae. Scutum microsculptured; notauli attenuated near scutal midlength; median scutal groove reduced to an elongate pit on posterior margin; scutal punctures sparse, present on posterior two-thirds, 3 or more puncture diameters apart. Scutellum microsculptured with several punctures in median lateral area. Mesopleuron microsculptured, impunctate; preomaular area without setae; hypersternaulus, scrobal sulcus, and omaulus foveolate. Metapleuron somewhat shiny, microsculpture weak, obscurely microstriate. Propodeum shiny, without microsculpture, entirely areolate, except small striate region near metapleur-

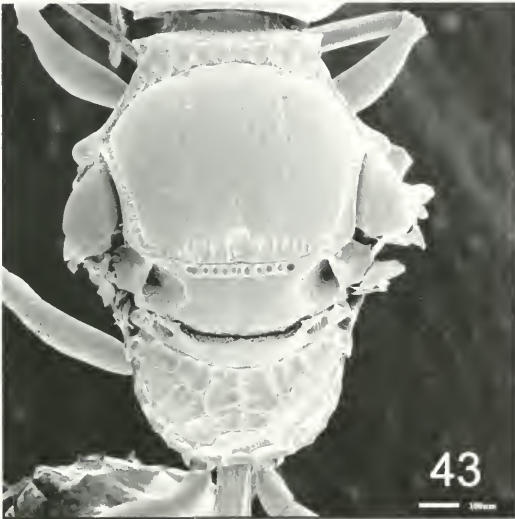

Figs. 41–44. *Incastigmus mystaxalbus* ♂. 41, Mid flagellomeres of antenna. 42, Head, dorsal. 43, Mesosoma, dorsal. 44, Mesosoma, lateral.

ron; propodeal enclosure not differentiated from lateral spheres. METASOMA. First tergum shiny, microsculpture obscure; succeeding terga with an oily sheen, without obvious microsculpture. Sterna somewhat more shiny with sparse punctures becoming increasingly dense on posterior sterna; punctures on sternum V about 2 diameters apart. COLOR. Black. White: palpi; mandible, except apex; sometimes clypeal apex; pronotal lobe. Yellow: scape; pedicel; ventral surface of flagellomeres I

to IV; forelegs beyond coxa; mid and hind trochanters; mid tibia and tarsus; hind tarsus.

*Female*.—Length 3.2–4.5 mm. Similar to male except as follows: flagellomere I length  $2.3 \times$  apical width; clypeus shiny, without microsculpture; median clypeal lobe with 2 teeth, and 2 long setae arising from 2 narrowly separated subapical pits; clypeus punctate on basal half, punctures about 2 diameters apart. OOD  $2.3 \times$  LOD. Scutum with microsculpture variable be-

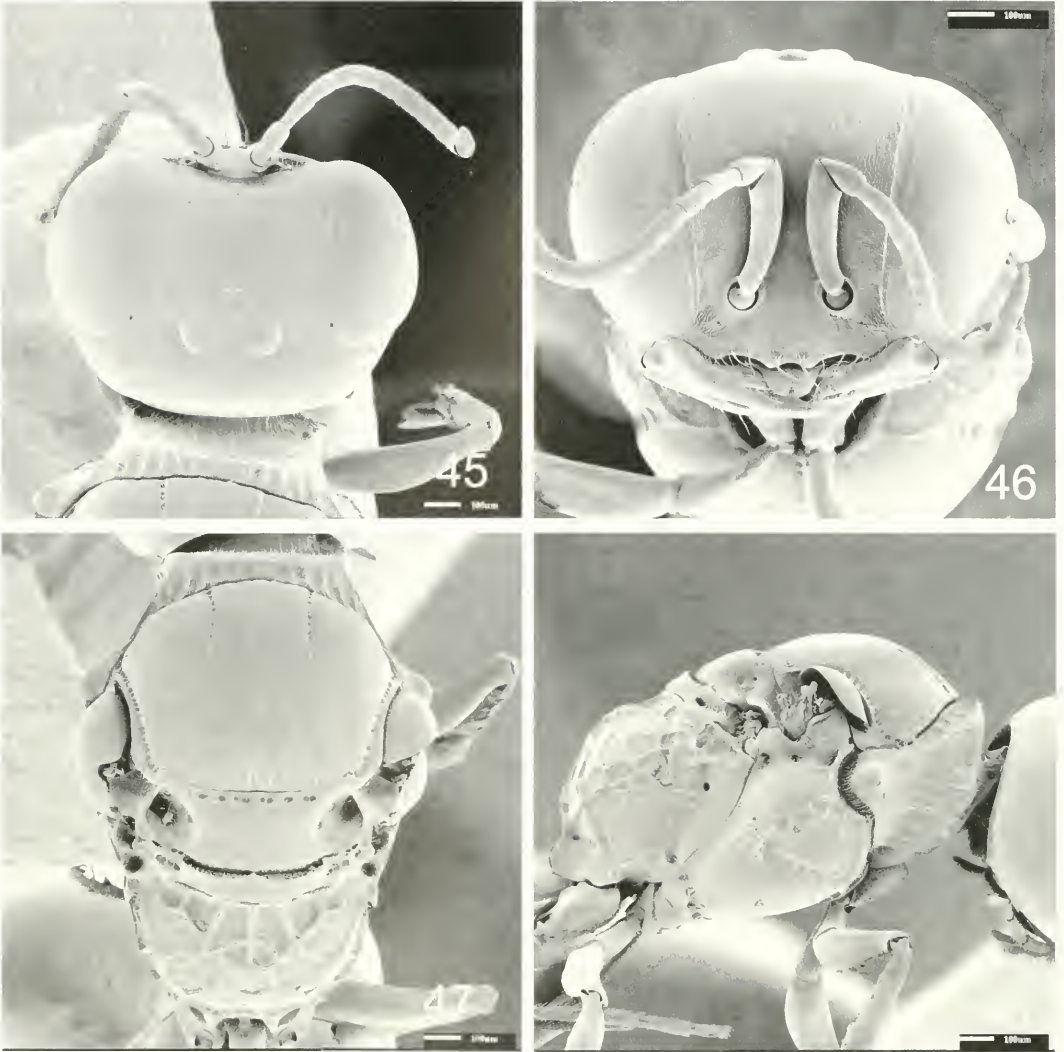

Figs. 45–48. *Incastigmus mystaxalbus* ♀. 45, Head, dorsal. 46, Face. 47, Mesosoma, dorsal. 48, Mesosoma, lateral.

tween absent and complete, with some specimens approaching a striatopunctate condition. Color similar to male, except apical half of clypeus white.

*Material Examined*.—23♂, 50♀. HOLOTYPE FEMALE: Mexico: Mor. Cuernavaca IV-1959 N. Krauss (USNM). Paratypes: **COSTA RICA**: [San Jose La Caja] b. H. Schmidt (4♀ NHMW). **Guanacaste**: S. Rosa Park: 1-XII-1976 D.H. Janzen riparian (1♀ AEIC); 13-XII-1976 D.H. Janzen dry hill (1♀ AEIC). 15-VIII-1977 D.H. Janzen

dry hill (1♀ AEIC). Sta. Rosa NP Sn. Emilio: 8-C, 8-II-2-III-1986 Janzen & Gauld (1♀ BMNH); 6-C, 2-23-III-1986 Janzen & Gauld (1♀ BMNH); 8-C, 4-24-V-1986 Janzen & Gauld (2♀ BMNH). Sta. Rosa NP Hacienda 1-0, 4-24-III-1986 Janzen & Gauld (1♀ BMNH). **San Jose**: San Jose: (2♀ MACN); Friesi-Schwerin Ankau♀ 1957 (2♀ SMTD); 27-VI-1925 Schmidt (4♀ CMNH). San Pedro de Montes de Oca 3-II-1935 C.H. Ballou (1♀ USNM). Santa Ana 24-II-64 3000', H.Evans (4♂ 1♀

MCZC). Tres Ríos, San Jose 1980 E. Tristan (1♂ NHMW). **EL SALVADOR: La Libertad:** Santa Tecla X-1965 N.L.H. Krauss (1♀ USNM). **HONDURAS:** [Suyapa Morazan] 3-XI-1965 N.L.H. Krauss (1♀ USNM). **Francisco Morazan:** Tegucigalpa:6-II-1918 F.J. Dyer no. 32981 (1♂ USNM); 16-II-1918 F.J. Dyer no. 35273 (1♂ USNM); 17-II-1918 F.J. Dyer no. 35396 (3♂ USNM); 19-II-1918 F.J. Dyer no. 36008 (1♂ 1♀ USNM). **GUA-TEMALA:** [no locality]1891. Schulth.-Rechbg (1♂ NHMW). [Panajachez] 27-IV-1978 R. Parks (1♂ SDMC). **Sacatepequez:** Antigua: IX-1959 N.L.H. Krauss (1♀ USNM); 1500–1600m VII-1980 M.L.H. Kreuss (2♀ PMAE). **MEXICO:** [Heredia] 13-II-1970 Peck (1♂ PMAE). Chris. 3000' 20mi N. [Huixtla] 6-VI-1969 W.R.M. Mason (4♀ CNCI). [Orizaba] XII-1887 H.H.S. & F.D.G. (1♂ BMNH). **Mexico:** Tejuipilco: Temescaltepec 19-VI-1933 H.E. Hinton, R.L. Usinger (1♀ CASC). **Michoacan de Ocampo:** Uruapan X-1954 N.L.H. Krauss (1♀ USNM). Uruapan 1600–1700m VIII-1975 N.L.H. Krauss (1♀ USNM). **Morelos:** Cuernavaca: 25-IX-1944 N.L.H. Krauss (1♀ USNM); III-1945 N.L.H. Krauss (2♂ 1♀ USNM); IV-1945 N.L.H. Krauss (2♂ 2♀ USNM); V-1945 N.L.H. Krauss (1♀ USNM); III,IV,V-1965 N.L.H. Krauss (1♂ USNM); X-1965 N.L.H. Krauss (1♀ USNM). Tlayacapan 29-X-1982 J.T. Huber (2♀ PMAE). **Nayarit:** María Magdalena: Is. Tres Marias 22-III-1964 R.R. Snelling (1♀ LACM). Tepic 15-17-IX-1953 B. Malkin (1♀ CASC). **San Luis Potosi:** orchid plants Maiz 18-X-1948 Laredo Tx 47405 48–16967 (3♂ 2♀ USNM). Huichihuayan 25-IX-1938 L.J. Lipovsky (1♀ SEMC). **Tamaulipas:** NE. Gomez Farias, Río Frio 5-VI-1983 M. Kaulbars (1♀ PMAE).

14. *Incastigmus mytior* Finnamore  
new species

Figs. 49–56

*Derivation of Name.*—The name *mytior* is derived from the Greek *myte*, meaning spiked, combined with *ior*, a Latin adject-

tival suffix, in reference to the toothed pronotal lobe.

*Diagnosis.*—Males of this species are easily recognized by a combination of a linear micropore field between the compound eye and lateral ocellus, and the sharply toothed, white pronotal lobe. Females can be recognized on the basis of the 2 narrowly separated subapical pits on the median clypeal lobe, pronotal lobe acute, toothed, and white, and the median scutal groove that attenuates near the scutal midlength and does not reach the admedian lines.

*Male.*—Length 3.75–4.5 mm. HEAD. Flagellomeres without ventral brush of specialized setae, but setose throughout, and with a few specialized setae at the apex of each flagellomere; linear tyli present on all flagellomeres, imparting an asymmetrical appearance and an obliquely truncate apex to flagellomere XI; flagellomere I length  $1.2 \times$  maximum width as measured with tylus in profile; flagellomere X length  $1.3 \times$  maximum width as measured with tylus in profile. Clypeus obscured by dense appressed setae which extend up frons along inner margins of eyes to half height of scape; frons microsculptured, vertex shiny, weakly microsculptured, with punctures sparse, irregular and 2 or more diameters apart; gena microsculptured, irregular microstriae present ventrally, without ventral tooth or swelling; genal punctures sparse, obscure; linear micropore field present between ocellus and compound eye, without depression behind it; lateral ocelli closer to each other than to eyes; OOD  $2.0 \times$  LOD. MESOSOMA. Transverse pronotal carina forming a right angle at humeral angle, toothed ventrally; transverse pronotal groove longitudinally striate; pronotal lobe acute, toothed, with anterior carina; lateral pronotal area longitudinally striate. Scutum microsculptured, more shiny on posterior half; punctures sparse, irregular, few to many diameters apart in median region; notauli attenuating near scutal

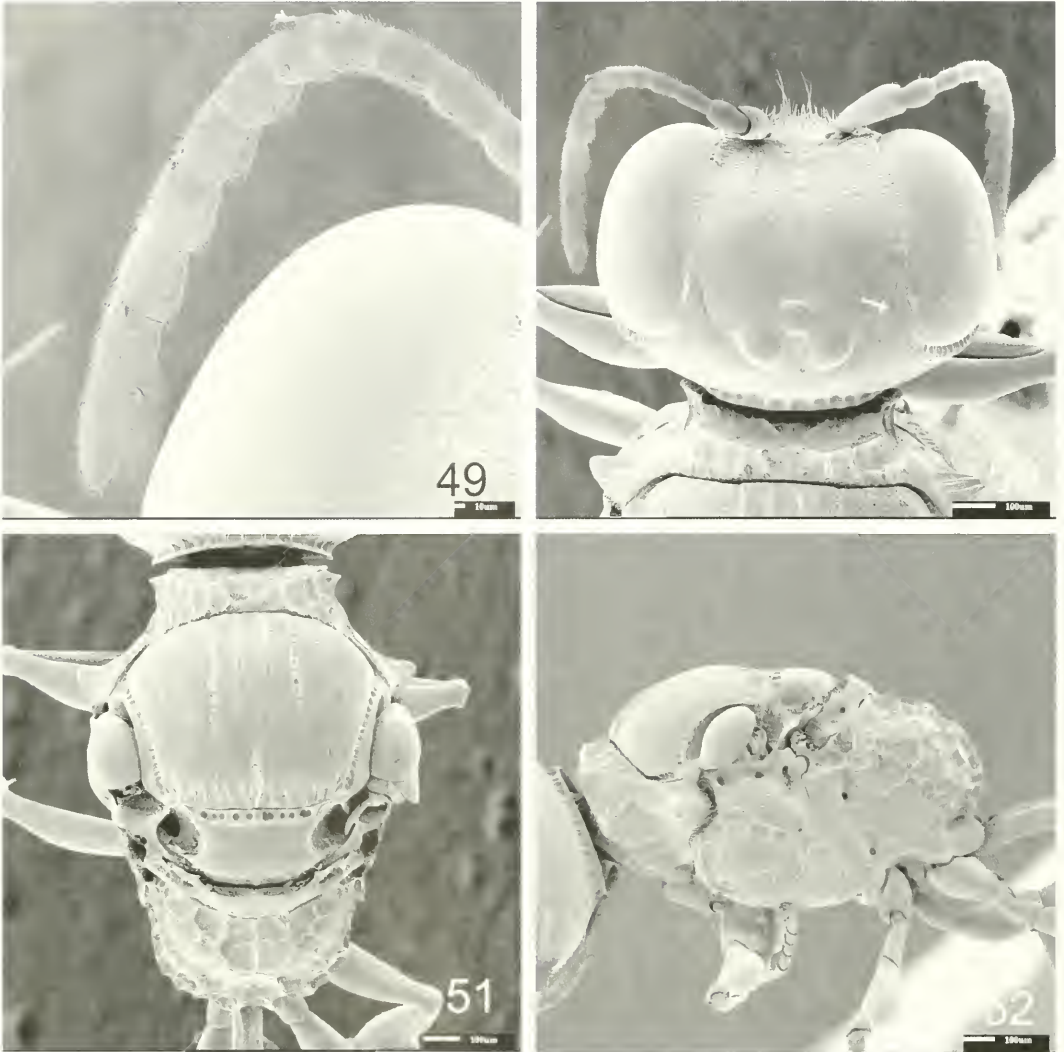

Figs. 49–52. *Incastigmus myrior* ♂. 49, Mid and apical flagellomeres of antenna. 50, Head, dorsal; arrow indicates micropore field. 51, Mesosoma, dorsal. 52, Mesosoma, lateral.

midlength; median scutal groove attenuating abruptly near scutal midlength; posterior margin of scutum with short ridges. Scutellum microsculptured, without median sulcus, and with scattered lateral punctures. Sculpture of preomaular area not obscured by setae. Mesopleuron shiny, weakly microsculptured, punctures few to many diameters apart; hypersternaulus, omalulus, and scrobal sulcus coarsely foveolate; metapleuron microsculptured, with longitudinal ridges along posterior

margin; propodeum areolate, except for shiny area adjacent to metapleuron; propodeal enclosure indicated by carina. METASOMA. First tergum shiny, succeeding terga with oily sheen; punctures minute, sparse, and obscure. Sterna with oily sheen, punctures increasing in density towards more posterior sterna and reaching maximum density on sternum VI where minute punctures are about 1 diameter apart in the median region. COLOR. Black. White: palpi; mandible, except apex; pron-

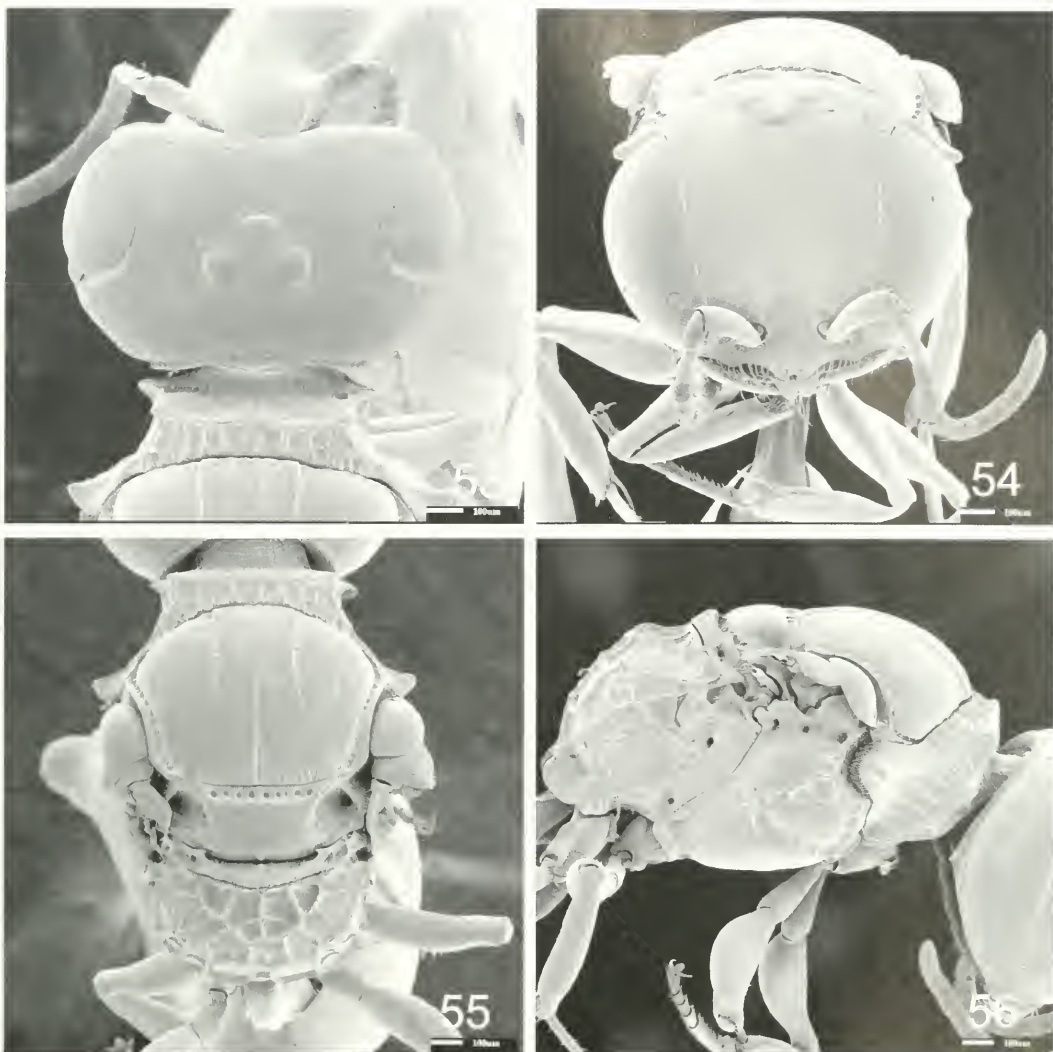

Figs. 53–56. *Lucastigmus mytior* ♀. 53, Head, dorsal. 54, Face. 55, Mesosoma, dorsal. 56, Mesosoma, lateral.

otal lobe. Yellow-brown: scape; pedicel; ventrally on flagellomeres I–III; tegula; fore leg, except coxa and femur; mid leg, except coxa and femur; hind tarsus.

*Female*.—Length 4.0–4.5 mm. Similar to male except as follows: antenna without tyli or specialized setae, flagellomere 1 length  $2 \times$  maximum width; clypeus shiny, punctures in median area 2 to 3 diameters apart; median clypeal lobe with 2 apical teeth separated by a narrow, V-shaped emargination, and with 2 narrowly separated subapical pits from which

arise long setae; vertex and upper frons shiny, without microsculpture, punctures more regular and about 3 to 5 diameters apart; gena without microsculpture, shiny; genal punctures sparse, irregular, 3 or more diameters apart; elongate triangular micropore field present between compound eye and lateral ocellus; OOD  $2.2 \times$  LOD; median scutal groove occasionally reaching admedian lines; and hind tibia, hind trochanter, and hind tarsus yellow-brown.

*Material Examined*.—24 ♂, 26 ♀. HOLO-

TYPE MALE: Peru: Cuzco Dept.: Agua Calliente 21-28-XII-1983 L. Huggert (PMAE). Type locality is at base of Machu Picchu. Paratypes: **BOLIVIA**: [no locality] 1♂ (NHMW). **La Paz**: Chulumani: 1,700m 26-III-1979 M. Cooper B.M. 1979-216 (1♂ BMNH); 1,700m 2-IV-1979 M. Cooper B.M. 1979-216 (1♀ BMNH). **BRAZIL**: **Mato Grosso**: Itaum Dourados III-1974 M. Alvarenga (1♂ CNCI). **Minas Gerais**: Ouro Preto IV-1954 N.L.H. Krauss (1♂ USNM). Serra do Caraca S. Barbara 1600m II-1969 F.M. Oliveira (1♀ AEIC). **Pernambuco**: Caruaru: 900m IV-1972 M. Alvarenga (1♂ 1♀ CNCI); V-1972 M. Alvarenga (1♂ PMAE); VII-1972 M. Alvarenga (2♀ CNCI). **Río de Janeiro**: Mangaratiba Muriqui VII-1969 M. Alvarenga (1♀ AEIC). **COLOMBIA**: **Cundinamarca**: Finca Bella Vista nr. Sasaima 7-VI-1965 P.R. & D.L. Craig (1♂ CASC). **Huila**: San Agustin 1,500m 8-XI-1971 M. Cooper B.M. 1972-275 (1♂ BMNH). **Valle del Cauca**: 6 mi W. Cali 1630m 20-III-1955 E.I. Schlinger & E.S. Ross (1♂ 1♀ CASC). Pance: (CVC) 12-XII-1974-3 R. Wilkerson Mt. (1♂ FSCA); 1,700m 15 km W. Cali 28-X-1974 very wet premontane forest R. Wilkerson Mt. (1♀ FSCA). Penas Blancas 1750m 10km W. Cali: 23-XII-1974 R.C. Wilkerson very wet premontane forest Mt. (2♀ FSCA); 15-I-1975 R.C. Wilkerson very wet premontane forest Mt. (1♀ FSCA); 20-22-I-1975 R.C. Wilkerson very wet premontane forest Mt. (3♀ FSCA); 27-I-1975 R.C. Wilkerson very wet premontane forest Mt. (2♀ FSCA); 31-I-1975 R.C. Wilkerson very wet premontane forest Mt. (2♀ FSCA); Penas Blancas: 12-II-1975 R. Wilkerson Mt. (1♀ FSCA); 26-28-II-1975 R. Wilkerson Mt. (1♀ FSCA); 5-7-III-1975 R. Wilkerson Mt. (2♀ FSCA); 21-27-IV-1975 R. Wilkerson Mt. (1♀ FSCA). **ECUADOR**: **Guayas**: Los Duen-des, S. Bolivar 10-VI-1965 Pena (1♂ MCZC). **Napo**: El Chaco 2000m II-1983 L. Masner, M. Sharkey (1♀ PMAE). Puerto Misahualli 30km E. 350m II-1983 M. Sharkey & L. Masner (1♂ PMAE). **Pastaza**: Puyo 44km S. 21-V-1977 D.L. & S.S. Vin-

cent (1♂ USNM). **Pichincha**: Peruchó 2000m 8-I-1974 L.E. Pena (1♂ AEIC). **Zamora-Chinchipe**: [Río Jumboe] 1-IV-1965 Pena (1♂ MCZC). **PERU**: **Cuzco**: Río Urubamba 3km above Machu Picchu 2050m 18-IV-1983 C. & M. Vardy B.M. 1983-217 (1♂ 1♀ BMNH). Machu Picchu 29-XI-1965 H. & M. Townes (1♂ AEIC). Agua Calliente 21-28-XII-1983 L. Huggert (1♂ PMAE). **Huanuco**: Huanuco 1,850m 19-20-III-1971 C. & M. Vardy B.M. 1971-533 (2♂ BMNH). **VENEZUELA**: **Lara**: Parque Nac. Yacambu: 6-8-IV-1981 E.E. Grissell (2♂ USNM); 1200m cloud forest 9-V-1981 H. Townes (1♀ PMAE). Yacambu 1200m 10-V-1981 H.K. Townes (1♂ AEIC).

15. *Incastigmus neotropicus* (Kohl)  
new combination

Figs. 57-64

*Stigmus neotropicus* Kohl 1890:64. Holotype, male (NHMW). Brazil, Neu-Granada, 1860; examined.

*Diagnosis*.—Males are distinguished on the basis of the linear micropore field between the compound eye and lateral ocellus, flagellomeres without ventral setal brush, flagellomere XI cylindrical, usually without tylus, and pronotal lobe rounded. Most females can be recognized by the dense appressed setae obscuring the clypeus and often the frons along the lower inner eye margin. In females of all other species, except *thoracicus* (which has a red thorax and no apparent median scutal groove), the surface of the clypeus is clearly visible between sparse setae. Females of *neotropicus* in which the clypeal setae are sparse, or have been worn off, are difficult to recognize, but the following characters may be of some assistance: clypeal lobe with 2 narrowly separated subapical pits; micropore field between compound eye and lateral ocellus small, narrowly elongate, triangular; lower gena without tooth or swelling; pronotal lobe rounded, white; scutum black, usually shiny posteriorly with weak microsculpture, and more or less irregularly ridged (sometimes with

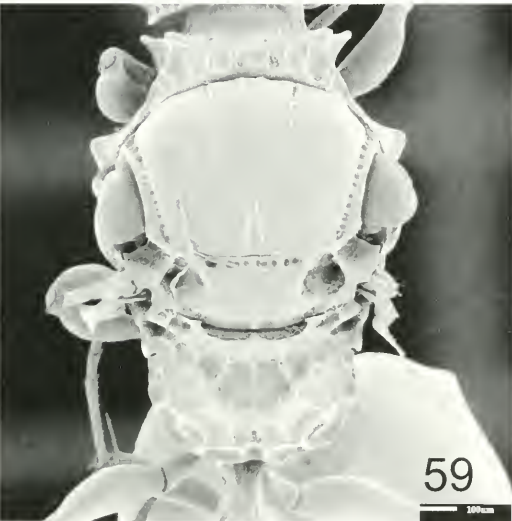

Figs. 57–60. *Incastigmus neotropicus* ♂. 57, Apical flagellomeres of antenna with tyli in profile. 58, Head, dorsal. 59, Mesosoma, dorsal. 60, Mesosoma, lateral.

strong irregular ridges); notauli incomplete, median scutal groove usually attenuating before or at admedian lines; metasomal tergum I shiny, without microsculpture.

This species is the most frequently collected *Incastigmus* and has the broadest distribution in the genus (Texas to Argentina). Several characters vary considerably in females and to a lesser extent in males, particularly the microsculpture of the head and scutum, clypeal setae, and the

degree of development of the irregular ridges on the scutum. Specimens from southern South America tend to have sparser clypeal setae in the female, completely microsculptured head, and more strongly developed irregular scutal ridges. Probably *neotropicus*, as defined here, represents 2 or more species, but even with the number of specimens on hand I am unable to find distinguishing characters, and therefore treat them all as a single species.

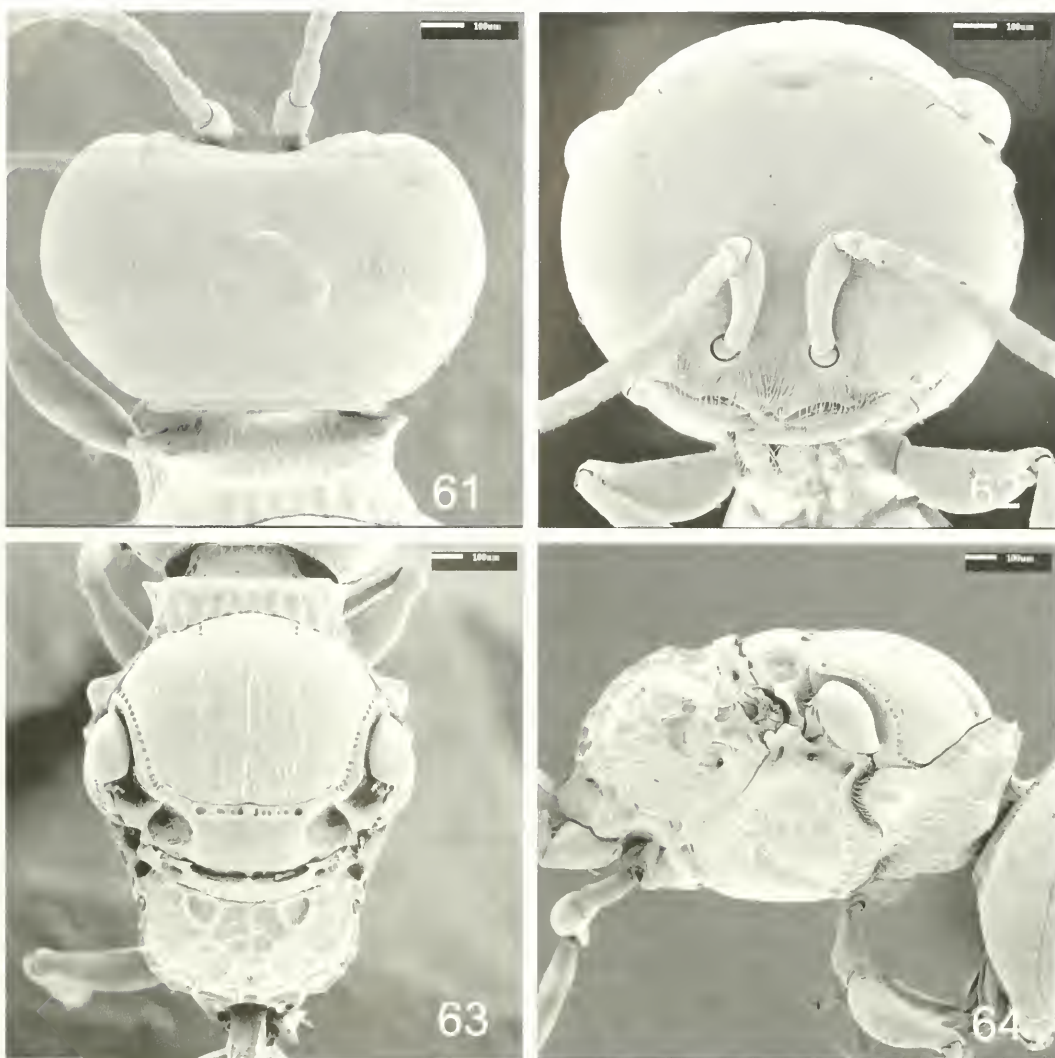

Figs. 61–64. *Incastigmus neotropicus* ♀. 61, Head dorsal. 62, Face. 63, Mesosoma, dorsal. 64, Mesosoma, lateral.

*Male*.—Length 3.5–4.75 mm. HEAD. Flagellomeres entirely setose, but without ventral brush of setae; linear tyli present on flagellomeres I–X, sometimes weekly present on flagellomere XI; flagellomere I length 1.2 to 1.3 × maximum width as measured with tylus in profile; flagellomere X length 1.5 × maximum width as measured with tylus in profile; flagellomere XI straight, cylindrical, apex conical. Clypeus obscured by dense appressed setae which extend up frons along inner margins of eye to 3/4 height of scape;

head variably microsculptured, microsculpture ranging from strong throughout to weakly microsculptured and shiny on ocellar region; head punctures sparse, irregular, 3 or more diameters apart on ocellar region; gena with microsculpture, sometimes weakened ventrally, without ventral tooth or swelling; genal punctures sparse, 3 or more diameters apart on lower region; linear micropore field present between compound eye and lateral ocellus; without depression behind it; OOD 1.3–1.5 × LOD. MESOSOMA.—Transverse

pronotal carina toothed at humeral angle, and toothed ventrally; transverse pronotal groove longitudinally striate; pronotal lobe rounded, with poorly defined anterior carina; lateral pronotal region longitudinally striate. Scutum entirely microsculptured to shiny with weak microsculpture on posterior half; scutal punctures sparse, irregular, usually 5 or more diameters apart on median region; notauli attenuating near scutal midlength; median scutal groove attenuating near scutal midlength, sometimes reaching admedian lines; posterior margin of scutum with several elongate ridges, but otherwise usually without ridges; scutellum microsculptured usually with median longitudinal sulcus and several punctures on lateral areas. Preomalar area anteriorly obscured by appressed setae. Mesopleuron usually densely microsculptured, but weakly microsculptured in some specimens; hypersternaulus, scrobal sulcus, and omalulus foveolate, usually more finely so than in other species; metapleuron microsculptured with several longitudinal ridges on posterior margin. Propodeum shiny, with at most weak microsculpture, areolate, except for shiny area adjacent to metapleuron; carinae defining propodeal areolae relatively low compared to those of other species; propodeal enclosure defined by carina and distinct from lateral spheres. **METASOMA.** First tergum shiny, without microsculpture; succeeding terga with oily sheen; tergal punctures minute, obscure, many diameters apart; sterna with oily sheen, punctures sparse, irregular and reaching maximum density on sternum V were punctures in lateral area are about 3 diameters apart. **COLOR.** Black. White: mandible, except apex; pronotal lobe. Yellow-brown: palpi; antenna entirely, or basal two-thirds; tegula; fore leg, except coxa; mid leg, except coxa; hind tarsus; sterna VI-VIII.

*Female.*—Length 4.0–4.5 mm. Similar to male except as follows: flagellomere I length  $1.7 \times$  maximum width, entirely se-

tose, but without ventral setal brush, tyli absent; sculpture of clypeus usually obscured by dense appressed setae which extend up frons along inner eye margin to about 1/3 height of scape; median clypeal lobe with 2 blunt teeth separated by a narrow emargination, and with 2 narrowly separated subapical pits from which long setae arise; in specimens where clypeal surface is visible, some microsculpture is evident; clypeal punctures sparse, irregular, 1 or more diameters apart in midregion; micropore field present as a narrow elongate triangle between compound eye and lateral ocellus; OOD  $1.8$  to  $2.4 \times$  LOD; posterior area of scutum of many specimens with varying degrees of irregular ridges; color slightly darker than in male, with basal half of antenna yellow-brown, and all femora darkened.

*Material Examined.*—223 ♂, 427 ♀. **ARGENTINA:** [Mis. San Ignacio-Montecarlo] (1♀ BMNH). [San Isidro] (5♂ PMAE). **Buenos Aires:** Berisso (5♂ 1♀ AEIC). Lomas de Zamora, Colombes, 17km S. Buenos Aires (1♀ BMNH). **Cordoba:** Cordoba (2♀ IIES). **Distrito Federal:** Buenos Aires (2♀ IIES, 17♀ MACN, 1♀ ZMAN). Buenos Aires, La Plata (2♂ 9♀ AEIC, 5♂ 51♀ MCZC). Buenos Aires, Moreno (5♂ 16♀ IIES). Buenos Aires, Punta Lara (2♂ 2♀ AEIC, 1♀ MCZC). **Entre Ríos:** Sta. Colon (1♂ IIES). Concordia (1♀ BMNH). [Pronunciamento] (3♀ FSAG). **Jujuy:** Ledesma (2♀ IIES). Posta Lozano (2♀ MCZC). **Misiones,** Puerto Esperanza (1♂ 2♀ IIES). **Santiago del Estero:** Lago Muyo (2♂ IMLA). R. Salado 10km ENE. Colonia Dora (3♀ BMNH). Thermas de Río Hondo (1♀ BMNH). **Salta:** El Tala 7km W. El Jardín 700m (1♀ RMNH). [Eusaccacion] (1♂ HNHM). Guemes—Yuto (1♀ AEIC). Orán, Abra Grande (3♀ MCZC). Pocitos (6♂ 3♀ IIES). Río Juramento (1♀ IMLA). Río Pescado, ca. Orán (3± IMLA). Rosario Lerma (7♂ 14♀ IIES). Tartagal (3♀ IIES, 1♂ 2♀ IMLA). Yacochuya (Cafayete) (2♀ IMLA, 2♀ MCZC). **Tucuman:** Amaicha del Valle (1♀ AEIC). Horco Molle, Tuc-

mán (1♀ CNCI, 2♂ 2♀ IMLA, 7♂ 5♀ MCZC, 3♂ 1♀ HNHM). Horco Molle, Tucumán; S. Pedro Colalao (1♀ IIES, 1♀ IMLA, 1♀ MCZC). Quebrada Lules, Tucumán (2♂ MCZC). Tucumán, Trancas Tacanas (1♂ IMLA). **BELIZE:** **Toledo:** Blue Creek (1♀ PMAE). **BOLIVIA:** [no locality] (3♂ NHMW). **Cochabamba:** Cochabamba (2♀ FSAG). Cochabamba—Santa Cruz km 335 (9♂ 6♀ IIES). **El Beni:** [Rurrenabaque] 175m (1♂ SEMC). Yungas Palmar, Chapare-Paracti (1♀ IIES). **La Paz:** Chulumani, 1,700m (1♂ 5♀ BMNH). La Paz (2♀ MCZC). Tumupasa (1♀ USNM). **Santa Cruz:** Buena Vista (1♀ IMLA). El Palmar (1♀ IMLA). Roboré (2♀ IIES, 1♀ SEMC). **BRAZIL:** [no locality] (1♀ NHMW). [Campinas] (3♀ BPBM). [Chapada] (1♂ CMNH, 2♀ USNM). [MG] Lavras (2♀ CSUC). [Neu-Granada] (1♂ NHMW). [Pará] (1♀ NHMW, 1♀ MPEG). **Amazonas:** R. Japura (1♀ MPEG). **Bahia:** [Energizilhada] 960m (1♀ PMAE). Itabuna CEPEC (3♀ BMNH). **Ceara:** Ser. Do Araripe 850m (1♂ 1♀ AEIC). Serra de Araripe, Crato (2♂ 1♀ PMAE). Serra de Baturite (3♀ MPEG). **Distrito Federal:** Brasília N.P. (2♀ PMAE). **Espirito Santo:** Colatina (1♂ 1♀ AEIC, 1♂ PMAE). **Goiás:** Jatai (3♀ CNCI). **Mato Grosso:** Itaum Dourados (2♀ CNCI). **Minas Gerais:** Aguas Vermelhas 15°45'S 41°28'W 800m (3♀ AEIC). [Azul] (2♀ PMAE). Ouro Preto (2♂ USNM). Pedra Azul (1♀ AEIC, 1♀ CNCI). Pocos de Caldas (1♀ PMAE). S. Caraça, S. Barbara (1♀ AEIC, 2♂ 1♀ PMAE). **Paraná:** Curitiba (1♀ MCZC). **Pernambuco:** Bonito (1♀ USNM). Caruaru (2♀ PMAE). Recife (1♂ BMNH). **Río de Janeiro:** Guan., Floresta de Tijuca [Río de Janeiro city?] I. (1♀ AEIC). Represa Río Grande: Guanabara (1♀ AEIC, 2♀ CNCI, 2♂ PMAE). Río de Janeiro (2♂ CMNH, 2♂ 1♀ USNM). Río de Janeiro, Campos (1♀ BPBM). Río de Janeiro, Gavea (1♂ BMNH). Río de Janeiro, Guanabara (1♀ CNCI). Río de Janeiro, Murundu (1♀ IIES). **Río Grande do Sul:** [no locality] (1♂ 1♀ NHMW). **Santa Catarina:** Nova Teutonia, 27°11'N 52°23'W (2♂ BMNH, 3♀ MCZC). Santa Catarina (1♀ BMNH, 4♀ OSUO, 2♂ 19♀ MCZC). **São Paulo:** Cosmopolis (1♂ SEMC). Mogi Guacu (1♀ CNCI). Peruibe (1♂ 1♀ USNM). S. Bocaina (1♂ PMAE). S.J. Barreiro, Serra de Bocaina (1♀ AEIC). São Paulo (4♂ 1♀ USNM, 14♂ 14♀ ZMUM). Villa Americana (2♀ BPBM). **COLOMBIA:** **Magdalena:** (1♀ PMAE). N. Sierra Nevada de S. Marta, Río Buritaca (1♀ BMNH). 12km E. Santa Marta (1♀ BMNH). 26km e Santa Marta (1♀ FSCA). **Meta:** Carimagua 17km S. El Porvenir (1♀ FSCA). Río Duda (1♂ BMNH). Villavicencio (1♀ BMNH). **Valle del Cauca:** Cali 3000–4000' (1♂ MCZC). Pance CVC 15km W. Cali (1♀ FSCA). **COSTA RICA:** **Cartago:** Turrialba (2♀ SEMC, 1♂ USNM). **Heredia:** La Selva Biol. Sta. 10°26'N 84°01'W (1♂ PMAE). **San Jose:** Santa Ana 3,000' (1♀ MCZC). **ECUADOR:** **Guayas:** Los Duendes, S. Bolivar (4♂ 5♀ MCZC). **Napo:** Puerto Miashualli, 30km E. (2♂ 1♀ PMAE). Tena 400m (4♂ 1♀ PMAE). Tena-Puyo Hwy. 5km N. Santa Clara (1♂ PMAE). **Pastaza:** Puyo (1♂ USNM). **Pichincha:** Guayllabamba 10km on Río Pisque 2,500m (2♀ PMAE). 16km SE. Sto. Domingo, Tinalandia 500m (1♀ CNCI). Tinalandia 800m (1♀ PMAE). **Zamora-Chinchipe:** Río Jumboe (Zamora) (1♂ AEIC, 2♂ MCZC). Yantzaza (1♂ 1♀ MCZC). **EL SALVADOR:** **La Libertad:** Santa Tecla 900–950m (2♂ USNM). **San Salvador:** San Salvador (2♂ 3♀ USNM). **GUATEMALA:** **Guatemala:** Guatemala City (3♂ BPBM). **MEXICO:** Chis., 32mi W. [San Cristobal] Jct. 190–195 Hwys. (1♀ CNCI) **Chiapas:** 100km SE. Palenque Bonampak (1♀ PMAE). **Oaxaca:** Donaji (1♀ ANIC). **San Luis Potosi:** El Bonito 7mi S. ciudad Valles 300' (1♂ CASC). **Sinaloa:** Villa Union (1♂ MCZC). **Veracruz-Llave:** Veracruz (1♂ BMNH, 1♀ USNM). **PANAMA:** **Canal Zone:** Tabernilla (1♀ USNM). **PARAGUAY:** [San Pedro/Grl. Artigas] (1♀ AEIC). **Caaguazu:** Caaguazu (1♀ IIES). **Central:** Asuncion (1♀ BPBM, 4♀ USNM). **Cordillera:** S. Bernardino (6♀

NHFW). **Itapua:** Pirapo (1♀ CNCI, 1♀ IIES). **PERU:** [Rio Perepe] (1♀ USNM). **Cuzco:** Cuzco-Abancay road, Apurimac crossing at Cuya 1,900m (1♀ BMNH). Quillabamba (2♂ 1♀ PMAE). Quincemil nr. Marcapata (1♂ AEIC). Río Urubamba 3km above Machu Picchu 2,050m (1♀ BMNH). **Huanuco:** Huanuco 1,850m (1♂ BMNH). [Los Palmas] SW 1,000m (1♂ CASC). Monzon Valley, Tingo María (3♂ 3♀ CASC). Tingo María (1♂ PMAE). Tingo María, Cueva de Las Pavas (1♀ IMLA). Tocache (1♀ PMAE). **Junin:** Satipo (1♂ PMAE). Satipo [Paratuchali] (1♂ PMAE). **Madre de Dios:** [Laberinto], 70km W. Puerto Maldonado (1♀ PMAE). **SURINAME:** **Marowijne:** 80km E. of Paramaribo on Albina Hwy. (1♀ PMAE). **TRINIDAD & TOBAGO:** [no locality] (1♂ MCZC). [Aripo Valley] (2♂ 3♀ FSCA). [Caranage] (1♀ USNM). Morne Bleu (1♀ AEIC). River Estate (1♂ USNM). **Caroni:** Brasso (1♂ BMNH). Gran Couva (2♂ 2♀ BMNH). Pepper (1♂ BMNH). **Nariva:** Ecclesville (1♀ BMNH). [Nariva Reservoir] (1♂ BMNH). [Machapore Hill] (1♀ BMNH). **Mayaro:** Trinity Hills Reserve (1♂ 1♀ BMNH). **Port-of-Spain:** Port-of-Spain (1♂ USNM). **St. George:** Arima-[Blanchisuisse] road 8<sup>th</sup> mi. (3♂ 1♀ USNM). Arena Reserve (2♀ BMNH). Arima Ward, Simla N.Y. Zool. Soc. Sta. (1♂ FSCA). Arima Valley (2♀ BMNH). Aripo Valley (2♀ BMNH). Caura (1♂ 1♀ BMNH). El Tucuche south slope (1♂ BMNH). El Tucuche west slope (1♂ 1♀ BMNH). Hillsborough Dam (1♂ 1♀ BMNH). Lopinot (1♂ 1♀ BMNH). Maracas Bay Village (4♂ 7♀ USNM). Maracas Valley (2♂ 1♀ BMNH). [Point Gourde] (1♀ BMNH). St. Augustine (6♂ 8♀ BMNH). Sta. Margarita, Curepe (1♂ 3♀ BMNH, 1♀ CNCI, 1♀ PMAE). Simla-Arima, Blanchisseuse Rd. nr. 4 1/4mi Post (1♂ 1♀ FSCA). Simla Field Sta. Arima Valley (8♀ FSCA). Simla Res. Sta. (3♀ FSCA). Tumpuna Reserve (1♀ BMNH). **St. Patrick:** Aripo Savanna (1♂ USNM). **San Fernando:** San Fernando Hill (2♂ USNM).

**Tobago:** [no locality] (1♂ BMNH). Adelphi, 1mi ESE. (5♂ 1♀ FSCA). Archibold Estate, Roxborough (8♂ USNM). Back Hill roadside 700' (1♂ 1♀ BMNH). Caledonia Rd. Cocoa plantation (1♂ BMNH). Roxburgh, Parlatuvier Rd. 2nd milestone (1♂ 1♀ BMNH). St. John, Blood Bay (1♀ BMNH). St. John, Cambleton (1♀ BMNH). St. John Prov. Hermitage River bridge, Charlotteville (1♂ USNM). St. Paul, Delaford (1♂ 1♀ BMNH). St. Paul, Parlatuvier Valley (1♂ 1♀ BMNH). **UNITED STATES:** **Texas:** Brownsville (1♂ CASC, 1♀ MCZC). Cameron Co., Southmost. (1♀ SEMC). Hidalgo Co., Bentsen Río Grande Valley St. Pk. (2♀ USNM). **VENEZUELA:** Miranda-[Nucleo El Lanrel] 1200-1300m (1♂ IZAV). **Bolívar:** La Gran Sabana, Rd. to Kavanayen, 9km Chivatón 1,310m. (1♂ MTEC). **Carabobo:** Los Guayos (1♂ 1♀ IZAV). **Distrito Federal:** Caracas (1♂ USNM). **Lara:** [no locality] (1♀ MCZC). Barquisimeto (1♀ MJMO). Cabudare 450m (1♂ MJMO). Sanare (1♂ AEIC). **Merida:** Merida, Sta. Rosa 2,000m (1♀ PMAE). **Zulia:** El Tucuco (3♀ AEIC, 2♀ PMAE). El Tucuco 45km SW. of Machiques (1♀ USNM). Maracaibo (2♀ AEIC).

16. *Incastigmus paranicus* Finnamore  
new species

Figs. 65-68

*Derivation of Name.*—The name *paranicus* is derived from the distribution of this species in the Río Paraná watershed of Southern South America.

*Diagnosis.*—Males of this species are easily recognized on the basis of the linear micropore field between the lateral ocellus and compound eye, pronotal lobe rounded, and a ventral setal brush on the flagellomeres. Females are more difficult to recognize, but the following combination of characters may help in recognition: clypeus with long setae arising from narrowly separated subapical pits on median clypeal lobe, clypeal surface not obscured by setae, gena without ventral tooth or

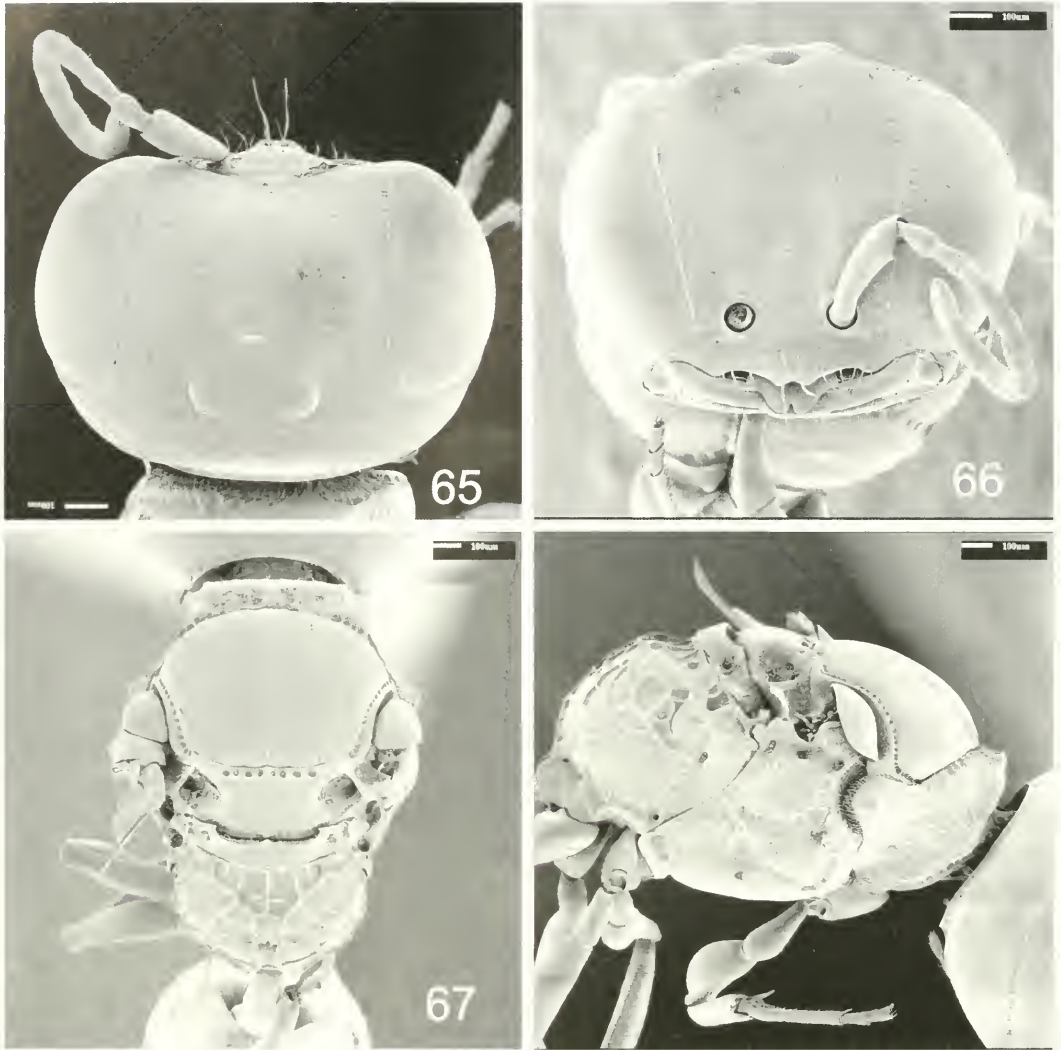

Figs. 65–68. *Incastigmus paranicus* ♀. 65, Head, dorsal. 66, Face. 67, Mesosoma, dorsal. 68, Mesosoma, lateral.

swelling, pronotal lobe rounded and white, mesosoma otherwise black, scutum with at most the median groove complete, mesopleuron with lower half of hypoepimeral area shiny and without microsculpture, foveae of omaulus, scrobal sulcus and hypersternaulus relatively small so that the mid mesopleural area appears comparatively larger, and metasomal tergum I shiny, without microsculpture. This species closely resembles *aylaxiter* and *neotropicus* from which it differs in the male by the ventral brush of setae on the fla-

gellomeres and in the female by less extensive microsculpture, particularly on the lower half of the hypoepimeral area (shiny in *paranicus* and dull in *aylaxiter*), and by the sparse setae of the clypeus (not obscuring the underlying sculpture in *paranicus*, unlike most *neotropicus*).

*Male*.—Length 3.75–4.5 mm. HEAD. Flagellomeres I–XI with tyli; tylus on flagellomere XI imparting an asymmetrical appearance, apex conical; flagellomeres with a ventral brush of specialized setae; flagellomere I length 1.5 × maximum width;

flagellomere X length  $1.5 \times$  apical width; clypeus obscured by dense appressed setae which extend up frons along inner eye margin to little more than the height of antennal socket; head nearly completely microsculptured, with microsculpture of frons merging with that of vertex; punctures of upper frons sparse, irregular, three or more diameters apart; gena microsculptured throughout, or more shiny in lower area, with punctures sparse, often obscured; gena smoothly rounded in ventral region without tooth or swelling; micropore field present as a long linear groove between compound eye and lateral ocellus; without depression behind it; OOD  $1.3$  to  $1.5 \times$  LOD. **MESOSOMA.** Transverse pronotal carina ending at humeral angle in a right angle and ventrally in a tooth; transverse pronotal groove of pronotum longitudinally carinate; pronotal lobe rounded with a weak anterior carina; lateral pronotal region with longitudinal striae; scutum microsculptured throughout, punctures sparse, irregular and 3 or more diameters apart; notauli attenuated near scutal midlength; median scutal groove attenuated near scutal midlength, sometimes reaching admedian lines; posterior margin of scutum with several short longitudinal ridges. Scutellum microsculptured with a weak median longitudinal sulcus and a few punctures laterally. Sculpture of preomalar area not obscured by setae. Mesopleuron weakly microsculptured, sometimes shiny, punctures sparse and many diameters apart; hypersternaulus, scrobal sulcus, and omaulus foveolate, with foveae relatively smaller than in other species, so that the mid mesopleural area appears comparatively larger. Mesopleuron weakly microsculptured, with short longitudinal carinae on posterior margin. Propodeum shiny, with microsculpture weak, if present; propodeum entirely areolate, except shiny area adjacent to metapleuron; propodeal areolae relatively weaker than in other species; propodeal enclosure well-

defined. **METASOMA.** Tergum I shiny, succeeding terga with an oily sheen; tergal punctures minute, sparse and obscure; sterna with an oily sheen, punctures sparse generally more dense medially and reaching greatest density on sternum VI were minute punctures are 1–2 diameters apart. **COLOR.** Black. White: pronotal lobe. Yellow-brown: mandibles, except apex; palpi; scape; pedicel; flagellomere I ventrally; tegula; fore leg, except coxa; mid-leg, except coxa; hind tarsus.

*Female.*—Length 4–4.5 mm. Similar to male except as follows: flagellomere I length  $1.7 \times$  maximum width; flagellomeres without tyli, entirely setose. Clypeus shiny, without microsculpture, with punctures sparse, separated by 2 or more diameters medially; median clypeal lobe with 2 teeth separated by slight emargination and long setae arising from pair of narrowly separated subapical pits; sculpture of frons along lower inner eye margin not obscured by setae; micropore field present as an oval or triangular elongate patch between compound eye and ocellus; OOD  $2.2 \times$  LOD. Color similar to male, except femora of legs darker.

*Material Examined.*—34 ♂, 60 ♀. **HOLOTYPE MALE:** Bolivia: Micapaca, La Paz 5-III-1968 Garcia & Porter (MCZC). Paratypes: **ARGENTINA: Catamarca:** Suncho 12-X-1968. Porter (1♀ MCZC). **Distrito Federal:** Bs. Aires 4-V-1912 J. B. (1♀ MACN). **Jujuy:** [Camino Cormisa] II-1984 Fritz (1♀ IIES). Jujuy: 12-I-1966 H. & M. Townes (1♀ AEIC); 14-I-1966 H. & M. Townes (1♀ AEIC). Los Perales 12-II-1951 Mouros, Willink (1♂ IMLA). Posta Lozano: 15-20-XII-1967 C. Porter (1♀ MCZC); 27-X-2-XI-1968 C. Porter (1♂ 12♀ MCZC); 21-23-III-1969 C. Porter (1♀ MCZC); 29-X-4-XI-1968 C. Porter (5♀ MCZC). Posta de Lozano: 21-23-III-1969 C. Porter (3♂ MCZC); 26-X-1969 C. Porter (1♀ IMLA). **Salta:** Ruta 51, El Golgota IV-1970 O.H. Casal (1♂ 1♀ IIES). Rosario Lerma X-1984 Fritz (9♂ 6♀ IIES). [Vezenyi], Metan I-1906 (1♀ HNHM). **Tucuman:** Dpto. Taff

Horco Molle 24-XI-1971 C. Porter (1♂ IMLA). Horco Molle, Tucuman: 6-15-X-1967 C. Porter (1♀ MCZC); 1-15-XI-1967 C. Porter (1♂ MCZC); 10-23-XII-1967 C. Porter (4♀ MCZC); 9-30-IV-1968 C. Porter (1♂ 1♀ MCZC); 1-9-X-1968 C. Porter (1♂ MCZC, 3♀ PMAE); IX-X-1968 C. Porter (2♀ MCZC, 1♀ CNCI); 15-IX-1-X-1968 C. Porter (1♀ MCZC); XII-1968 C. Porter (1♀ CNCI). Villa [Nogues] 24-XII-1965 H. & M. Townes (5♂ 1♀ AEIC). Horco Molle, Tucuman, Parque Sierra San Janvier 700m 15-1-1976 L. Stange (1♂ 2♀ IMLA). [San Janvier]: 21-X-1950 M. Aczel (1♂ IMLA); 1100m VII-1977 R. Goldbach MT (1♀ FSCA); 1100m 1-15-XII-1977 R. Golbach (2♀ FSCA). S. Pedro Colalao 15-19-XII-1964 C. Porter (3♂ MCZC). Tacanas 10-XII-1977 L. Stange (1♀ FSCA). Trancas Fritz (3♂ IIES). 20km W. S.M. de Tucuman 10-XII-1971 D.J. Brothers (1♀ SEMC). Villa Nougues: 5-8-XII-1964 1250m C. Porter (1♀ MCZC); 13-I-1966 L. Stange (1♀ IMLA). Villa Padre Monti (1♀ IIES). **BOLIVIA: La Paz:** [Micapaca] 5-III-1968 Garcia & Porter (2♂ MCZC). **BRAZIL: São Paulo:** São Paulo: 20-VIII-1968 V.N. Alin (1♀ USNM); 14-X-1968 V.N. Alin (1♀ USNM).

17. *Incastigmus propherodontis*  
Finnamore new species

*Derivation of Name.*—*Propherodontis* is derived from the Greek terms, *prophorixos*, meaning oral, and *odontis*, meaning tooth, in reference to the slight tooth-like swelling on the lower gena of the female.

*Diagnosis.*—Females of this species are similar to *hexagonalis* in possessing a tooth-like swelling on the lower genal region, the tooth is smaller. Also, the median clypeal lobe does not terminate in a pair of teeth separated by a deep emargination (as it does in *hexagonalis*), but is truncate and without teeth. Males of this species are more difficult to separate from other species. They do not have a swelling on the lower gena and therefore cannot be confused with *hexagonalis*. The following

combination of characters will separate the males of this species its congeners: the median scutal groove contiguous with the admedian lines; flagellomeres without tyli, and length not more than  $2 \times$  apical width; extensive shiny areas on vertex, gena, and posterior  $2/3$  of scutum; micropore field oval; pronotal lobe rounded; and the mesosoma black.

*Male.*—Length 3.5 mm. HEAD. Flagellomeres without tyli or specialized setae; flagellomere I length  $2 \times$  apical width; flagellomere X length  $1.2 \times$  apical width; flagellomere XI straight, cylindrical, apex conical. Clypeus obscured by dense appressed setae which do not extend up frons along inner eye margin; frons microsculptured; vertex shiny, sparsely punctate, punctures 2 or more diameters apart; a small oval micropore field present between compound eye and lateral ocellus; without depression behind it; gena shiny, with sparse irregular punctures, with those of ventral region 3 or more diameters apart; gena without ventral tooth, or swelling; lateral ocelli closer to each other than to compound eyes; OOD  $1.6 \times$  LOD. MESOSOMA. Transverse pronotal carina toothed at humeral angle, and toothed medially and ventrally (6 teeth total); transverse pronotal groove longitudinally striate; pronotal lobe rounded with a weak anterior carina; lateral pronotal area longitudinally striate. Anterolateral third of scutum weakly microsculptured, otherwise shiny, with strong, sparse, punctures, 4 or more diameters apart; notauli extending to the posterior third of the scutum; median scutal groove extending anteriorly to the admedian lines; posterior scutal margin with several short ridges parallel to median groove. Scutellum shiny, microsculptured posteriorly, with median longitudinal sulcus well developed and several punctures in the median lateral area. Mesopleuron shiny, without microsculpture, with several scattered punctures; premaular area anteriorly with sparse setae and sculpture visible;

hypersternaulus, scrobal sulcus, and omaulus, coarsely foveolate; metapleuron weakly microsculptured, with several longitudinal striae. Propodeum shiny, with weak microsculpture, coarsely areolate except area adjacent to metapleuron which is shiny and irregularly microstriate; propodeal enclosure not differentiated from lateral spheres. METASOMA. Tergum I shiny, without microsculpture, with sparse obscure punctures; succeeding terga with oily sheen. Sterna shiny, without microsculpture, punctures sparse and irregular, increasing only slightly in density on more posterior sterna. COLOR. Black. White: tip of pronotal lobe. Yellow-brown: palpi; mandible, except apex; antenna; pronotal lobe, except tip; tegula; fore leg, except coxa and fore femur; mid tibia and tarsus; hind tibia and tarsus; apical sterna.

*Female*.—Length 4.5–5.0 mm. Similar to male except as follows: clypeus shiny, sparsely setose, sparsely punctate; clypeal punctures in median area 2 or more diameters apart; median clypeal lobe truncate, without teeth, long setae arising from subapical pits on median clypeal lobe; sculpture of frons along inner eye margin not obscured by appressed setae; lower gena with a small swelling adjacent to hypostomal carina; OOD  $2.4 \times$  LOD; pronotal lobe pointed, conical; color as in male, except white basally on mandibles, and yellow-brown on pronotal lobe, and mid-leg, except coxa.

*Material Examined*.—1 ♂, 7 ♀. HOLOTYPE FEMALE: Brazil: Goias: Jatai XI-1972 F.M. Oliveira (CNCI). Paratypes: **BOLIVIA: La Paz:** Chulumani 1,700m 26-III-1979 M. Cooper B.M. 1979–216 (1♀ BMNH). **BRAZIL: Minas Gerais:** Aguas Vermelhas 15°45'S 11°28'W 800m XII-1983 Alvarenga (1♀ AEIC). **COLOMBIA: Cauca:** [San Andres de Pisimbaia] c 60km E. of Popayan 15-16-X-1971 1800m M. Cooper B.M. 1972–275 (1♀ BMNH). **ECUADOR: Napo:** Tena, 23-II-1923 F.X. Williams (1♂ BPBM). **PANAMA: Canal Zone:** Summit X-1946 N.L.H. Krauss (1♀

USNM). **TRINIDAD & TOBAGO: St. George:** Arena Reserve 31-VII-1976 J.S. Noyes B.M. 1976–462 (1♀ BMNH). **VENEZUELA:** [San Esteban] X-1939 P. Anduze (1♀ USNM).

#### 18. *Incastigmus pycnoglypticus* Finnamore new species

*Derivation of Name*.—The name *pycnoglypticus* is derived from the Greek *pycnos*, meaning dense, and *glypticos*, meaning sculptured, in reference to the dense microsculpture of the first metasomal tergum.

*Diagnosis*.—The dull, densely microsculptured first metasomal tergum of this species is unique in the genus.

*Male*.—Length 4.5–5.0 mm. HEAD. Flagellomeres without tyli or brush of specialized setae; flagellomere I length  $1.8 \times$  maximum width; flagellomere X length  $1.3 \times$  maximum width; flagellomere XI straight, cylindrical, apex conical. Clypeus obscured by dense appressed setae which extend up frons along inner margin of eyes to height of antennal socket; head microsculptured, almost uniformly so; vertex and frons not distinguished from each other by differences in microsculpture, with punctures sparse; micropore field present as an oval patch between lateral ocellus and compound eye, without depression behind it; gena microsculptured throughout, obscurely punctate, nonstriate, without ventral swelling or tooth; lateral ocelli closer to each other than to compound eye, OOD  $1.9 \times$  LOD. MESOSOMA. Transverse pronotal carina toothed at humeral angle and ventrally; transverse pronotal groove longitudinally striate; pronotal lobe rounded, not produced, carinate, or toothed; lateral pronotal area with longitudinal striae. Scutum microsculptured; scutal punctures sparse, irregular, 3 or usually many more diameters apart; notauli attenuated posteriorly near scutal midlength, median scutal groove not reaching admedian lines, attenuated anteriorly near scutal midlength. Scutel-

lum microsculptured, with several punctures laterally. Mesopleuron dull, microsculptured, impunctate. Preomalar area without setae; hypersternaulus with several coarse foveae; scrobal sulcus and omaulus foveolate; metapleuron dull, microsculptured, impunctate. Propodeum dull, microsculptured, coarsely areolate over lateral spheres and propodeal enclosure which are not differentiated; irregular striae adjacent to metapleuron. METASOMA. First tergum dull, microsculptured; succeeding terga with oily sheen, without obvious microsculpture. Sterna somewhat more shiny than terga, with sparse punctures becoming increasingly dense on posterior sterna. COLOR. Black. White: pronotal lobe. Yellow-brown: mandible, except apically; palpi; scape; pedicel; and flagellomeres I-V; fore leg, except coxa and median two-thirds of femur; mid leg beyond femur; hind tarsus.

*Female*.—Length 5.5–6 mm. Similar to male except as follows: flagellomere I length  $2.1 \times$  maximum width; clypeus shiny, sparsely punctate, sparsely setose; median clypeal lobe with a pair of teeth separated by a median emargination; with long setae arising from subapical pits in median teeth. OOD  $3.5 \times$  LOD.

*Material Examined*.—2 ♂, 7 ♀. HOLOTYPE FEMALE: Brazil: Nova Teutonia: Sta. Cat. 18-11-1962 Fritz Plaumann (MCZC). Paratypes: **BRAZIL**: [Maua] X-20, NLH Krauss (1♂ USNM). **Río Grande do Sul**: Río Gr. do Sul: Stieglmayr (1♀ NHMW). **São Paulo**: São Paulo: (1♂ 5♀ ZMUM).

19. *Incastignus pyrrophyxis* Finnamore  
new species  
Figs. 69–76

*Derivation of Name*.—*Pyrrophyxis* is derived from the Greek *pyrrhos* meaning flame-colored, and *pyxis* meaning box, in reference to the orange-red mesosoma of most individuals of this species.

*Diagnosis*.—The red pronotum and the prominent lateral teeth are sufficient to

distinguish males and females of this species from all others in the genus. This species is distinguished from *thoracicus* by the well-developed median scutal groove. Females can be distinguished from *ignithorax* on the basis of the bidentate clypeus, and distinguished from its closest relatives *caelukhus* and *trichodocerus* by extensive red coloration and the presence of microsculpture on the vertex and hypopimeral area.

*Male*.—Length 3.5–4 mm. HEAD. Flagellum with a brush of setae on the ventral surface; tyli absent; flagellomere I length  $1.8 \times$  apical width; flagellomere X length  $1.3 \times$  apical width; flagellomere XI straight, cylindrical, apex conical. Head microsculptured, with microsculpture more dense on frons, weaker on ocellar region, and more dense on posterior vertex; clypeus obscured by dense appressed setae which extend narrowly up frons along inner eye margin about  $\frac{2}{3}$  height of scape; micropore field present as an oval patch between lateral ocellus and compound eye, without a depression behind it; gena microsculptured, sparsely punctate, nonstriate; lower gena shiny, without ventral swelling; lateral ocelli closer to each other than to eyes, OOD  $1.6 \times$  LOD. MESOSOMA. Transverse pronotal carina toothed at humeral angle, and ventrally; transverse pronotal groove with longitudinal striae; pronotal lobe rounded; lateral pronotal area longitudinally carinate. Scutum microsculptured anteriorly, shiny posteriorly; notauli often reaching posterior margin of scutum; median scutal groove present and complete; scutal punctures few and sparse. Scutellum with microsculpture. Mesopleuron microsculptured, impunctate; setae of preomalar area absent; hypersternaulus, scrobal sulcus, and omaulus, coarsely foveolate. Metapleuron weakly microsculptured. Propodeum shiny, without microsculpture, coarsely areolate over most of surface, unsculptured basolaterally; propodeal enclosure not differentiated from lateral spheres. METASOMA. Terga shiny, without

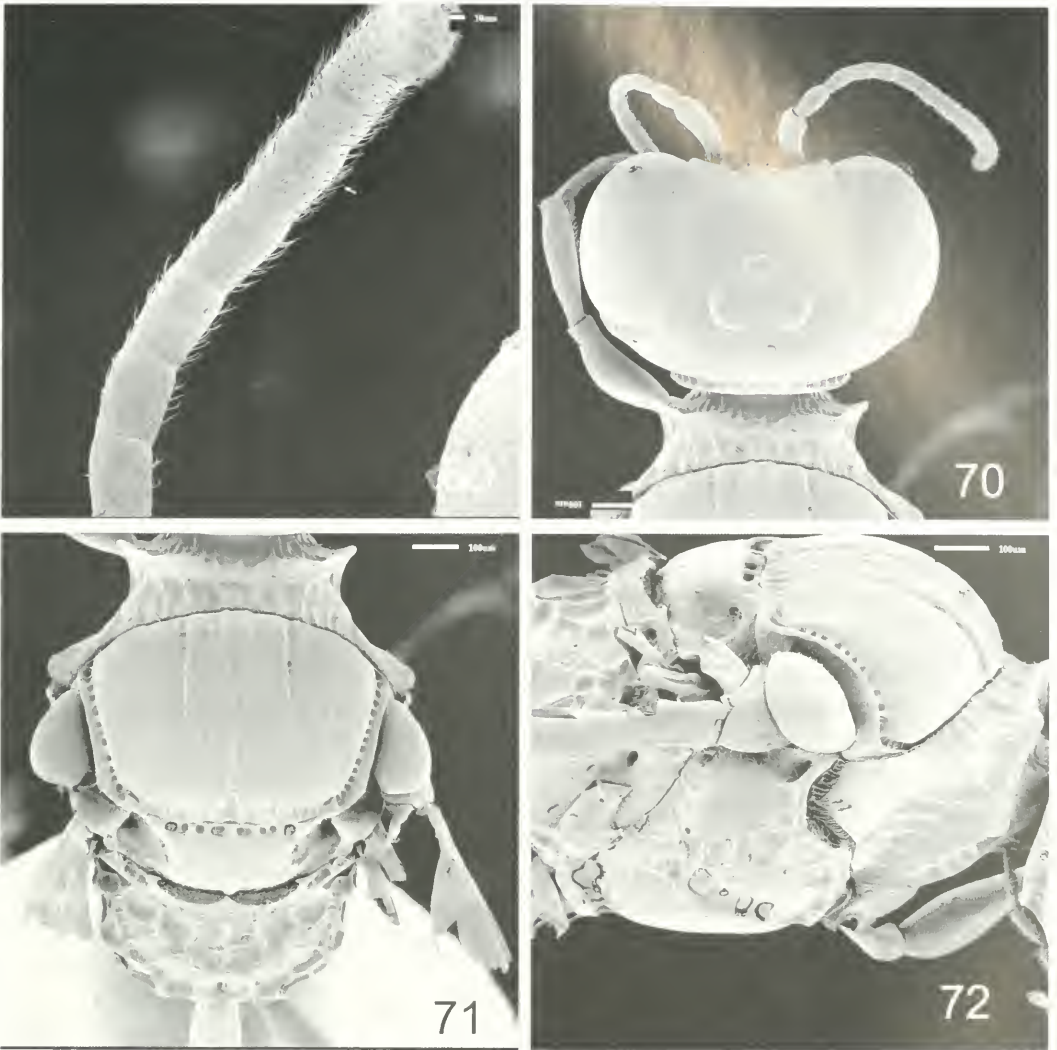

Figs. 69–72. *Incastigmus pyrrhopyxis* ♂. 69, Mid flagellomeres of antenna with arrow indicating ventral setal brush in profile. 70, Head, dorsal. 71, Mesosoma, dorsal. 72, Mesosoma, lateral.

microsculpture; tergal punctures obscure, sparse. Anterior sterna shiny; posterior sterna weakly microsculptured, with punctures sparse, obscure. COLOR. Dark form: Black. Orange-red: pronotum, tergum VII. Yellow-brown: antenna, palpi, tegula, fore leg, mid leg, hind tibia basally, hind tarsus. White: mandible basal to apical teeth, pronotal lobe. Light form: Black. Orange-red: mesosoma. Yellow-brown: antenna; fore leg; mid leg; hind leg; tegula.

White: mandible basal to apical teeth; palpi; pronotal lobe.

*Female*.—Length 3.5–4 mm. Similar to male except as follows: flagellomere I length  $2.6 \times$  apical width; clypeus shiny, with several punctures, setae sparse; median clypeal lobe weakly emarginate, long subapical setae arising from narrowly separated pits; OOD  $1.6 \times$  LOD; color as above for light form, except propodeum rarely red.



Figs. 73-76. *Incastigmus pyrrophyxis* ♀. 73, Head, dorsal. 74, Face. 75, Mesosoma, dorsal. 76, Mesosoma, lateral.

*Material Examined*.—14 ♂, 27 ♀. HOLOTYPE MALE: COSTA RICA: Cartago, Turrialba 550 m CATIE 4-IX-1986. L. Masner (PMAE). Paratypes: COLOMBIA: Choco: 950-1000m 5°50'N 76°20'W 7-8-IV-1973 J. Helava Montane Rain Forest (1♀ PMAE). Magdalena: Bonda, Aug. Acc. No. 1999 (2♂ CMNH). Meta: Cord. Macarena 15-28-II-1976 M. Cooper B.M. 1976-305 (1♂ BMNH). Narino: Barbacoas 23-III-1974 M. Cooper B.M. 1974-327 (1♀ BMNH). Valle del Cauca: 3.2km E. Río

Aguaclara on old Cali Road 19-III-1967 R.B. Root, W.L. Brown (1♀ MCZC). COSTA RICA: Cartago: Turrialba C.A.T.I.E. Reventazon Gorge 10-IX-1980 J. Woolley (2♂ PMAE). Turrialba CR49F19 (2♀ USNM). Turrialba 15-18-VII-1965 P.J. Spangler (1♀ USNM). Guanacaste: Cañas 12mi SW 27-II-1964 25' H.E. Evans (1♂ MCZC). Heredia: F. La Selva 3km S. Pto. Viejo 10°26'N 84°01'W 1-IV-1985 H.A. Hespeneheide (1♂ USNM). F. La Selva 3km S. Pto. Viejo 10°26'N 84°01'W 11-IV-1989

H.A. Hespeneide (1♂ PMAE). F. La Selva 3km S. Pto. Viejo 10°26'N 84°01'W 26-VI-1985 H.A. Hespeneide (1♀ USNM). Pto. Viejo 50m II-1980 W. Mason, rain forest (1♀ CNCI). **Puntarenas:** Las Tablas ENE. Las Mellizas 15km ENE. San Vito 28-V-1987 A.L. Norrbom (1♀ USNM). Manuel Antonia N. P. 28-VIII-1981 L. Masner (2♀ PMAE). Manuel Antonia N. P. 23-VIII-1986 L. Masner (1♀ PMAE). Manuel Antonia N. P. 24-VIII-1986 L. Masner (3♀ PMAE). Manuel Antonia N. P. 26-VIII-1986 L. Masner (6♀ PMAE). **ECUADOR:** **Napo:** Limoncocha 250m 15-28-VI-1976 S. & J. Peck (1♀ CNCI). **Pichincha:** 49km S. Sto. Domingo, Río Palenque Sta. 22-27-II-1976 S. Belwood (1♂ CNCI). Río Palenque 22-27-II-1976 (1♀ CNCI). 47km S. Sto. Domingo Río Palenque Sta. II-1976 Howden (1♀ CNCI). Tinalandia 2-II-1983 Masner, Sharkey (1♀ PMAE). **PERU: Loreto:** Iquitos NE. Río Nanay 6-II-1984 L. Huggert (1♀ PMAE). **TRINIDAD AND TOBAGO:** **St. George:** El Tucuche S. slope 25-VII-1976 J.S. Noyes Brit. Mus. 1976-462 (1♀ BMNH). **Tobago:** Rep. P. 21-22-IX-1918 G-229 H.P. Dietz (4♂ USNM).

## 20. *Incastigmus strepsilineatus* Finnamore new species

*Derivation of Name.*—The name *strepsilineatus* is derived from the Greek *strevlos*, meaning twisted, and the Latin *linea*, meaning line, in reference to the fingerprint-like propodeal sculpture of this species.

*Diagnosis.*—This species, known from a single male, can be recognized by the sculpture of its propodeum. This sculpture consists of fingerprint-like raised lines on the lateral areas and on the lateral spheres. Areolae are absent over these areas, absent on the propodeal enclosure, and absent on the posterior surface. The lack of areolate propodeal sculpture is unique in the genus. The presence of a linear micropore field indicates relationship with *neotropicus*, *parauicus*, *aylaxiter*, *mytior*, and *ceronius*.

*Male.*—Length 3.5 mm. HEAD. Flagellomeres without specialized setae, tyli present as a line or fold on flagellomeres I to VII; flagellomere I length  $1.5 \times$  maximum width; flagellomere X length  $1.3 \times$  apical width; flagellomere XI straight, cylindrical, apex conical. Clypeus obscured by dense appressed setae which extend up frons along inner eye margin to  $\frac{3}{4}$  height of scape; Head microsulptured, with vertex more shiny with weaker microsulpture; punctures of vertex sparse, irregular, 5 or more diameters apart in the median region; gena with weak microsulpture, sparsely punctate, without ventral tooth or swelling; micropore field present as a linear fold between compound eye and ocellus; without depression behind it; OOD  $1.4 \times$  LOD. MESOSOMA. Transverse pronotal carina slightly toothed at humeral angle and ventrally; transverse pronotal groove, with weak longitudinal striae; pronotal lobe rounded, without anterior carina; lateral pronotal area longitudinally striate. Scutum shiny over posterior  $\frac{2}{3}$  of surface, microsulptured anteriorly, with punctures sparse, irregular throughout, and 2 or more diameters apart on median area; notauli attenuating in posterior half of scutum; median scutal groove attenuating anteriorly near scutal midlength, not reaching admedian lines; posterior margin of scutum with a series of weak longitudinal ridges. Scutellum shiny, weakly microsulptured, without median sulcus, and with several punctures on lateral areas. Preomalar area with setae not obscuring underlying sculpture. Mesopleuron shiny, without microsulpture over most of surface; hypersternaulus, scrobal sulcus, and omaulus finely foveolate. Metapleuron shiny, without microsulpture and with several weak striae along posterior margin. Propodeum with fingerprint-like striae laterally, and on lateral spheres; propodeal enclosure defined by a carina, and irregularly, longitudinally striate. METASOMA. First tergum shiny, without microsulpture; succeeding terga with

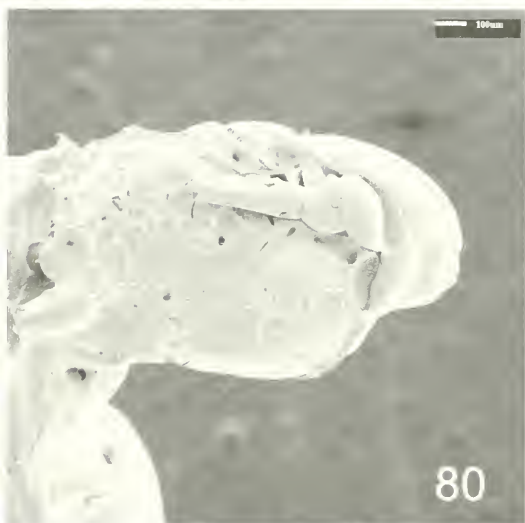
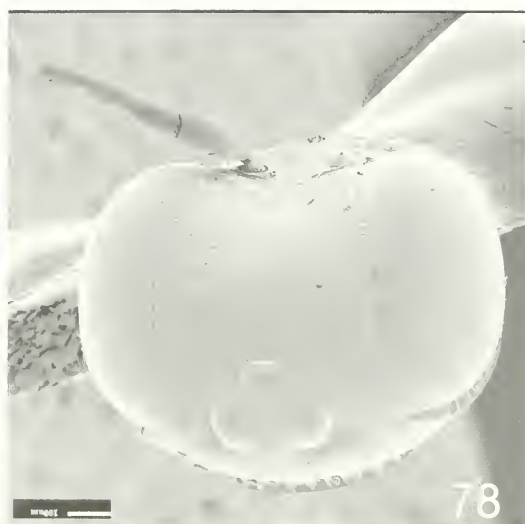

Figs. 77-80. *Incastignus sunicerus* ♂. 77, Scape, pedicel, and basal 2 flagellomeres. 78, Head, dorsal. 79, Mesosoma, dorsal (prothorax missing). 80, Mesosoma, lateral (prothorax missing).

an oily sheen, punctures minute, sparse, obscure. Sterna shiny, with oily sheen, punctures sparse, irregular and not increasing in density on more posterior sternae. COLOR. Black. White: mandible, except apex; pronotal lobe. Yellow-brown: palpi; antenna; tegula; fore leg; mid leg; apex of hind coxa, hind trochanter, hind tibia, and hind tarsus.

*Female*.—Unknown.

*Material Examined*.—1 ♂. HOLOTYPE MALE: Venezuela: GU, San Juan de los

Morros 8-VIII-1964 J. & B. Bechyne (IZAV).

21. *Incastignus sunicerus* Finnamore  
new species  
Figs. 77-80

*Derivation of Name*.—*Sunicerus* is derived from the Quichuan word *sun*, meaning long, and the Greek *keros*, meaning horn, in reference to the elongate antenna found in this species.

*Diagnosis*.—Males of this species are

easily distinguished by the elongate basal flagellomeres which reach well over  $2 \times$  their apical widths. Females, unfortunately are not easily distinguished and are difficult to diagnose. The following combination of characters will help to identify females: clypeus with 2 long setae arising from a subapical transverse depression; clypeal sculpture visible, not obscured by dense appressed setae; gena without ventral tooth or swelling; occipital carina slightly raised ventrally; micropore field large, about  $0.5 \times$  OOD; mesosoma black, without red coloration, and with extensive shiny areas; pronotal lobes white, rounded; notauli incomplete, attenuated medially near scutal midlength; metasomal tergum I shiny, without microsculpture.

*Male*.—Length 4.0–5.0 mm. HEAD. Flagellomeres without tyli or specialized setae; flagellomere I length  $2.3 \times$  apical width; flagellomere X length  $2.0 \times$  apical width; flagellomere XI about  $2 \times$  flagellomere X, and curved with roundly-truncate apex. Clypeus obscured by dense appressed setae which extend up frons along inner margins of eyes to about half height of scape; frons microsculptured, punctures obscure; microsculpture of vertex slightly less than that of frons, punctures sparse, 3 or more diameters apart; gena microsculptured, obscurely punctate, without ventral tooth or swelling; large oval microsculpture field ( $0.5 \times$  OOD) present between lateral ocellus and compound eye; without depression behind it; OOD  $1.4 \times$  LOD. MESOSOMA. Transverse pronotal carina forming a tooth at humeral angle and ventrally; transverse pronotal groove longitudinally striate; pronotal lobe rounded, conical, anterior carina poorly developed; lateral pronotal area longitudinally striate. Scutum microsculptured anteriorly, shiny with less microsculpture posteriorly; scutal punctures on anterior half obscure, on posterior half course, 3 or more diameters apart; notauli extending slightly beyond scutal midlength and attenuating posteriorly; median scutal groove extending to

admedian lines; posterior scutal margin with, short, weak irregular carinae. Scutellum microsculptured, with several mediolateral punctures. Mesopleuron microsculptured and apparently impunctate; hypersternaulus, scrobal sulcus, and omaulus coarsely foveolate; metapleuron microsculptured, without longitudinal carinae. Propodeum shiny, weakly microsculptured, coarsely areolate, except area adjacent to metapleuron which is not sculptured; propodeal enclosure not differentiated from lateral spheres. METASOMA. Terga shiny, without microsculpture, succeeding terga with oily sheen, punctures obscure. Sterna with weak microsculpture, with punctures reaching greatest density on sternum III and beyond, 3 or more diameters apart. COLOR. Black. White: palpi; base of mandible; pronotal lobe. Yellow-brown: mandible, except base and apex; scape; pedicel; flagellomeres I-IV; tegula; fore leg, except coxa; mid leg, except coxa; hind trochanter, hind tarsus; and apical sternum.

*Female*.—Length 4–5 mm. Similar to male except as follows: flagellomere I length  $1.6 \times$  apical width; flagellomere X  $1.3 \times$  apical width; flagellomere XI about  $1.5 \times$  length of flagellomere X, and straight. Clypeus with setae not obscuring underlying sculpture, with relatively dense, close punctures, separated in median area by 1–2 diameters; median clypeal lobe consisting of 2 teeth separated by a shallow emargination, with a subapical transverse depression from which long setae arise; frons along inner eye margin sparsely setose, sculpture not obscured; OOD  $2.2 \times$  LOD.

*Material Examined*.—24 ♂, 16 ♀. HOLOTYPE MALE: Brazil: MG: Ouro Preto IV-1954 N.L.H. Krauss (USNM). Paratypes: BRAZIL: Minas Gerais: Barbacena 26-X-1905 Ducke (1♂ MPEG). Ouro Preto IV-1954 N.L.H. Krauss (3♂ 1♀ USNM). São Paulo: Ribeirão Pires: VI-1954 N.L.H. Krauss (1♂ USNM); 28-VI-1961 N.L.H. Krauss (2♂ USNM). São Paulo: (2♂ 3♀

ZMUM); 20-VIII-1968 V.N. Alin (2♂ USNM); 13-XII-1968 V.N. Alin (1♂ USNM); 10-X-1977 (1♂ ZMUM); 24-X-1977 (1♀ ZMUM); 12-IV-1978 (4♂ 1♀ ZMUM); 9-II-1979 (1♀ ZMUM); 25-VII-1979 (1♂ ZMUM); 16-VIII-1979 (3♀ ZMUM); 6-XII-1979 (1♀ ZMUM); 28-I-1981 (2♂ 1♀ ZMUM); 17-II-1981 (1♂ 1♀ ZMUM); 10-III-1983 (2♂ ZMUM). [Sao Vi] IX-1961 N.L.H. Krauss (1♀ USNM). **Rio de Janeiro:** Represa Rio Grande, Guanabara V-1972 M. Alvarenga (1♀ PMAE). **Santa Catarina:** Nova Teutonia, XII-1967 F. Plaumann (1♂ MCZC).

## 22. *Incastigmus thoracicus* (Ashmead)

*Stigmus thoracicus* Ashmead 1900: 223. Holotype, female (BMNH). St. Vincent W.I., H. Smith 238/ W. Indes 99–331 B.M. type Hym. 21.885; examined.

*Stigmus smithii* Ashmead 1900: 223. Holotype, male (BMNH). W. Indes 99–331 B.M. Hym. type 21.886; examined. Ashmead (1900) incorrectly described this specimen as a female.

*Diagnosis.*—Specimens with more extensive red coloration are distinguished by their red petiole. Darker (and lighter) specimens are distinguished by the full reduction of the median scutal groove, shiny hypopimeral area, and rounded corners of the transverse pronotal carina.

*Male.*—Length 3.0–3.8 mm. HEAD. Flagellomeres without tyli or specialized setae; flagellomere I length 2.0 × apical width; flagellomere X length 1.1 × apical width; flagellomere XI straight, cylindrical, apex conical. Head microsculptured, almost uniformly so; clypeus obscured by dense appressed setae which extend broadly up frons along inner eye margin to height of scape; vertex and frons uniformly microsculptured; upper frons and vertex with slightly less microsculpture and with sparse, obscure punctures; micropore field present as an oval patch between compound eye and lateral ocellus; without depression behind it; gena microsculptured, sparsely punctate, non-

striate, without ventral swelling or tooth; lateral ocelli closer to each other than to eyes. OOD 2.0 × LOD. MESOSOMA. Transverse pronotal carina rounded at humeral angle, not toothed or produced; transverse pronotal groove with weak longitudinal striae; pronotal lobe rounded, not toothed; lateral pronotal area with several weak striae. Scutum shiny, weakly microsculptured; punctures minute, sparse; notauli present anteriorly; median scutal groove undeveloped, evident posteriorly as one of many weak foveae on posterior scutal margin. Scutellum and mesopleuron shiny, without microsculpture; mesopleuron impunctate, except sternopleural region with minute sparse punctures; pre-malar area anteriorly with sparse setae; hypersternaulus without foveae; scrobal sulcus and omaulus weakly foveolate. Metapleuron microsculptured on ventral half, otherwise shiny, impunctate. Propodeum shiny, without microsculpture over most of basolateral surface and dorsolateral spheres; basolateral propodeal area adjacent to metapleuron without sculpture; propodeal enclosure weakly areolate, with smaller areolae than on dorsolateral spheres, the 2 groups of areolae separated by a smooth unsculptured area. METASOMA. Terga shiny, without microsculpture, punctures sparse, obscure. Sterna weakly microsculptured, punctures sparse but increasing in density on posterior sterna. COLOR. Dark form: Black. White: palpi; mandible, except apex; spot on pronotal lobe; hind tibia on base. Yellow to yellow-brown: antenna; pronotum, except dorsally and spot on pronotal lobe; mesopleuron, anteriorly; fore leg; mid leg; hind trochanter and tarsus; tegula. Light form: Black. White: palpi; mandible, except apically; spot on pronotal lobe; fore tibia and tarsus; mid tibia and tarsus; basal half or more of hind tibia, and tarsus. Yellow-orange: antenna; mesosoma, except propodeal dorsum; fore leg, basal to tibia; mid leg, basal to tibia; hind leg, basal to tibia

and apex of tibia; petiole, except ventral apex; apical 1 or more sterna.

*Female*.—Length 3.9 mm. Similar to male except as follows: flagellomere I length  $3.0 \times$  apical width; clypeus shiny, with several punctures, setae sparse; clypeal lobe with a pair of median teeth separated by a shallow emargination and from which arise long setae; frons along inner eye margin sparsely setose, with sculpture not obscured; OOD  $2.5 \times$  LOD; color, as above for light form, except white on scape and orange on clypeus and propodeal dorsum.

*Material Examined*.—5 ♂, 3 ♀. **DOMINICA**: Springfield (2♂ 2♀ USNM). Point Casse Rd (1♂ USNM). **GRENADE**: 2500 feet (1♂ MCZC). Botanical Garden (1♀ USNM). **ST. VINCENT**: [no locality] (1♀ BMNH). **WEST INDIES**: [no locality] (1♂ BMNH).

### 23. *Incastigmus trichodocerus* Finnamore new species

Figs. 81–88

*Derivation of Name*.—The name *trichodocerus* is derived from the Greek *trichodes*, meaning hairy, and *keros*, meaning horn, in reference to the specialized setae on the ventral surface of the antennae of members of this species.

*Diagnosis*.—Males can be recognized by the specialized setal brush on the ventral surface of the flagellum, shiny vertex, and oval micropore field. Females can be distinguished from other species on the basis of the median clypeal lobe which has a subapical semicircular depression, and a hypopimeral area which is without microsculpture on at least its ventral half. This species closely resembles *pyrrhopyxis* and *caelukhus*, which share a setal brush on the ventral surface of the flagellomeres. However, neither of these species has a shiny vertex in the male, or a shiny hypopimeral area in the female.

*Male*.—Length 3.5–4.0 mm. HEAD. Flagellomeres with a ventral brush of short setae, tyli absent; flagellomere I length 1.8

$\times$  apical width; flagellomere X length  $1.3 \times$  apical width; flagellomere XI straight, cylindrical, apex conical. Clypeus obscured by dense appressed setae which extend up frons along inner margins of eyes to about half height of scape; frons coarsely microsculptured, frons with area anterior to mid ocellus shiny, usually weakly microsculptured, sometimes without microsculpture; punctures on upper frons and vertex sparse, more or less evenly spaced, 3 or more diameters apart; oval micropore field present between compound eye and lateral ocellus, without depression behind it; gena weakly microsculptured with scattered punctures, without ventral tooth or swelling; lateral ocelli closer to each other than compound eye; OOD  $2.0 \times$  LOD. MESOSOMA. Transverse pronotal carina forming a right angle at humeral angle and toothed ventrally; transverse pronotal groove longitudinally striate; pronotal lobe rounded, without anterior carina; lateral pronotal area longitudinally striate. Scutum variable, generally some degree of irregular longitudinal ridges present posteriorly, and microsculpture variable from absent to present on posterior half; notauli reaching mid-length of scutum, usually attenuating shortly thereafter, sometimes reaching posterior margin; median scutal groove reaching admedian lines and contiguous for short distance with them. Scutellum shiny or with weak microsculpture and a few lateral punctures. Preomaular area with sparse setae. Mesopleuron shiny, microsculpture not present; punctures weak, sparse, many diameters apart; hypersternaulus, scrobal sulcus, and omaulus coarsely foveolate. Metapleuron microsculptured, with several short longitudinal ridges on posterior margin with propodeum. Propodeum shiny, without microsculpture, or sometimes with weak microsculpture; propodeum coarsely areolate except for shiny, unsculptured area adjacent to metapleuron; propodeal enclosure not differentiated from lateral

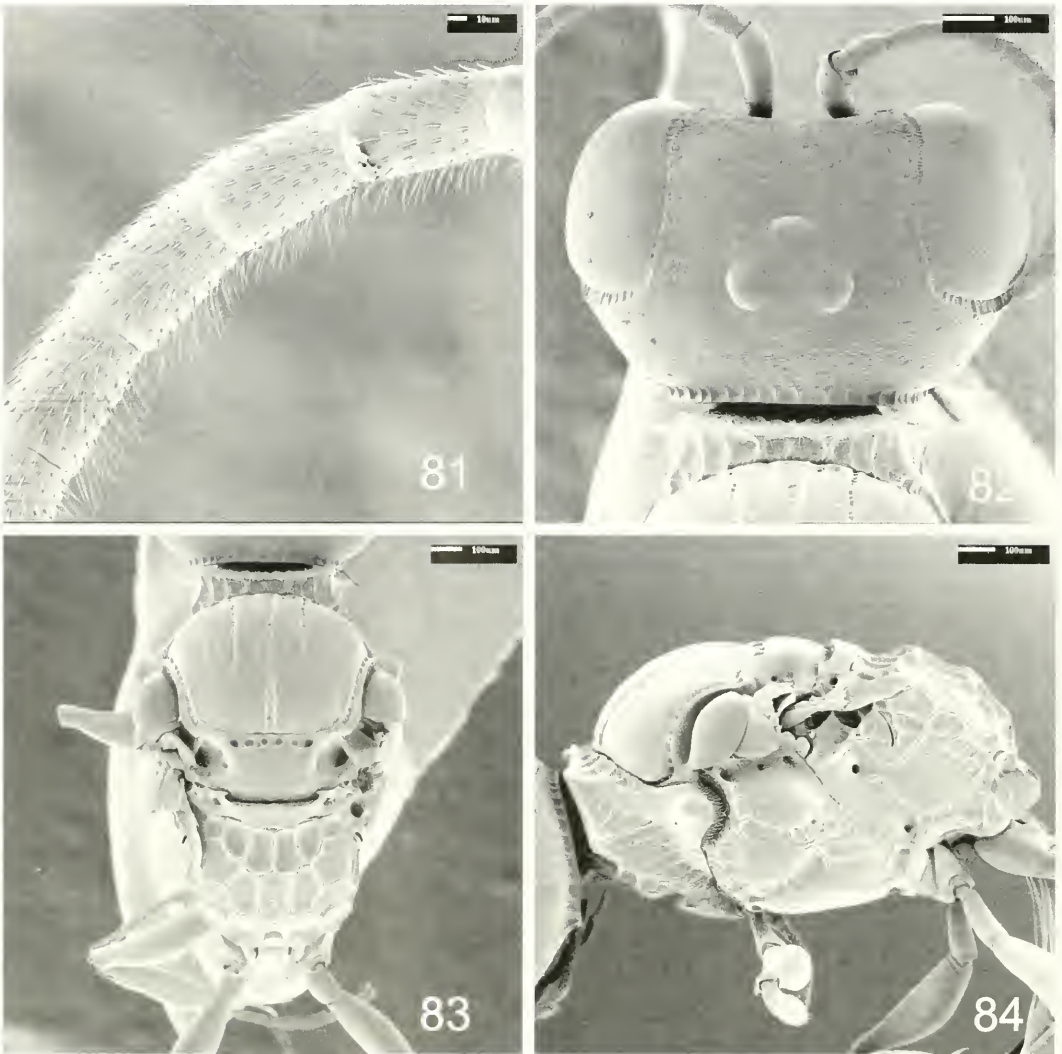

Figs. 81–84. *Incastignus trichodocerus* ♂. 81, Mid flagellomeres of antenna with setal brush (erect setae) in profile. 82, Head, dorsal. 83, Mesosoma, dorsal. 84, Mesosoma, lateral.

spheres. METASOMA. First tergum shiny, without microsculpture, succeeding terga with an oily sheen, punctures minute, sparse, many diameters apart; sterna shiny, without microsculpture, with oily sheen; punctures sparse on anterior sterna but increasing in density on more posterior sterna; punctures on sternum VI about 2 diameters apart on lateral area and impunctate medially. COLOR. Black. White: mandible except apex; pronotal lobe. Yellow-brown: palpi; scape; pedicel;

ventrally on flagellomeres I–V or more; tegula; fore leg, except coxa; mid leg, except coxa and femur; hind tarsus; apical tergum and sternum.

*Female*.—Length 4.0 mm. Similar to male except as follows: flagellomeres with ventral setae, but not forming a brush; flagellomere I length  $1.7 \times$  apical width; clypeus shiny, setae sparse, sometimes with weak microsculpture, punctures 1–2 diameters apart medially; median clypeal lobe truncate with subapical semicircular

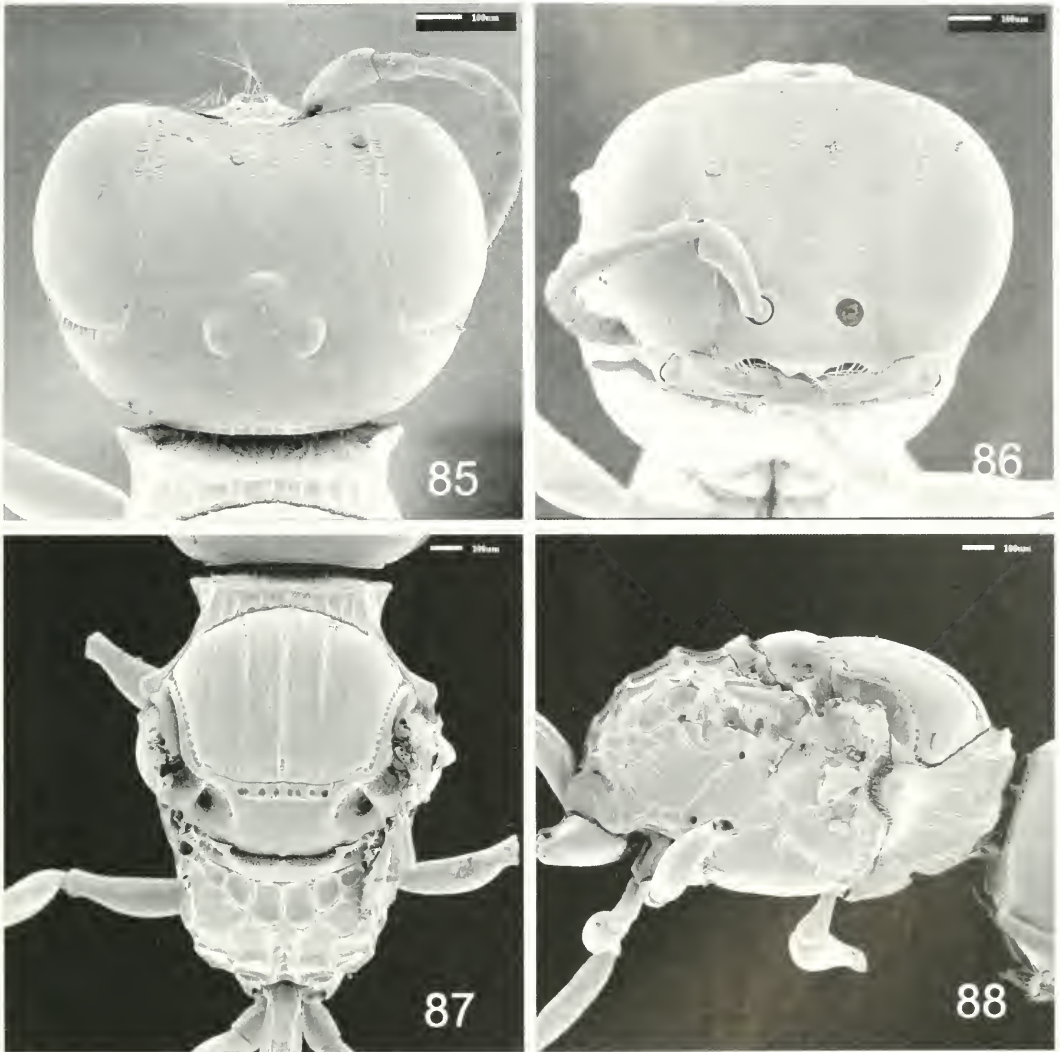

Figs. 85-88. *Incastignus trichodocerus* ♀. 85, Head dorsal. 86, Face. 87, Mesosoma, dorsal. 88, Mesosoma, lateral.

depression from which long setae arise; frons along inner eye margin between compound eye and antennal socket partially obscured by setae; OOD  $1.8 \times$  LOD; notauli of scutum often reaching posterior scutal margin; punctures of sternum VI on lateral regions about 1 diameter apart.

**Material Examined.**—75 ♂, 147 ♀. HOLOTYPE MALE: Ecuador: Pichincha Prov. Tinalandia, 16 km S. Sto. Domingo 15-VI-1975 S. & J. Peck (PMAE). Paratypes: **BRAZIL:** São Paulo: São Paulo (1 ♀

ZMUM). **COLOMBIA:** Meta: Restrepo 18-VI-1974 L. Stange (1 ♀ IMLA). **Norte de Santander:** Santiago 2-4000' 11-V-1974 J Peck (1 ♂ PMAE). **ECUADOR:** [Bucay] 1000': 9-X-1922 F.X. Williams (1 ♀ BPBM); 10-X-1922 F.X. Williams (1 ♂ 1 ♀ BPBM). [Huigra] 4000' 31-V-1923 F.X. Williams (1 ♀ BPBM). **Los Ríos:** Quevedo IV-1976 Fritz (1 ♀ IIES). **Napo:** Puerto Misahualli 350m II-1983 Sharkey (1 ♀ PMAE). **Pichincha:** Garrapata W. Sto. Domingo 28-XII-1970 Luis E. Pena (1 ♂ AEIC). Quito/S.

Domingo 600/1000m 3-I-1971 Luis E. Pena (1♂ AEIC). Río Palenque: II-1976 G.E.S (1♂ PMAE); 22-II-1976 G. Shewell (1♀ PMAE); 22-27-II-1976 (1♀ CNCI); 4-II-1983 Masner & Sharkey (6♂ 1♀ PMAE). Río Palenque Res. Sta. II-1983 200m M. Sharkey & L. Masner (8♂ 4♀ PMAE). 16 km S. Sto. Domingo 15-VI-1975 S. & J. Peck (10♂ 23♀ PMAE); 44km S. Santo Domingo Río Palenque Res. Sta. 22-27-II-1976 J. Belwood (1♀ CNCI). 47 km S. Sto. Domingo Río Palenque Sta.: 22-31-VII-1976 S. & J. Peck (4♂ 4♀ CNCI); 29-IV-5-V-1987 Brown & Coote 160–180m rainforest (4♀ PMAE). Sto. Domingo 16km SE. Tinalandia 500m 4-14-VI-1976 S. & J. Peck (12♂ 52♀ CNCI). 15 km E. Sto. Domingo Tinalandia 2000' 25-26-II-1981 Howden (1♀ PMAE). Tinalandia: 680m 15-30-VI-1975 S. & J. Peck (2♂ PMAE); 14-VI-1976 S. & J. Peck (2♂ 16♀ PMAE); 2-II-1983 M. Sharkey & L. Masner (6♂ 9♀ PMAE); 800m II-1983 M. Sharkey & L. Masner (8♂ 2♀ PMAE); 800m III-1983 M. L. Masner & M. Sharkey (1♂ 5♀ PMAE). Tinalandia, 16km SE. Sto. Domingo 14-VI-1976 S. & J. Peck (1♀ PMAE). Tinalandia, 16km SE. Sto. Domingo 680m 15-30-VI-1975 S. & J. Peck (11♀ CNCI, 1♀ PMAE). **Tungurahua:** Yanayacu 300m 29-30-VIII-1977 L.E. Pena B.M. 1978–293 (1♂ BMNH). **PARAGUAY:** **Cordillera:** Piareta XII-1971 Pena (1♀ IIES). **PERU:** **Cuzco:** Quillabamba 23-27-XII-1983 L. Huggert (3♂ PMAE). **Huanuco:** Tingo María 10-12-VII-1974 C. Porter, L. Stange (1♂ IMLA). 26mi E. Tingo María 1100m 10-XII-1954 E.I. Schlinger, E.S. Ross (1♂ CASC). **Junin:** Satipo 18-I-1984 L. Huggert (1♂ PMAE). **Piura:** [Querecotillo] 23-VII-1982 R.B. Miller, L.A. Stange (1♂ FSCA). **SURINAME:** **Brokopondo:** Brownsberg 12-18-I-1985 T.W. Thormin (1♀ PMAE). **TRINIDAD & TOBAGO:** **Tobago:** Archibald Estate, Roxborough 6-XI-1918 H. Morrison (1♀ USNM). **VENEZUELA:** **Zulia:** El Tucuco 200m 26-IV-1981 L. Masner (1♂ PMAE). Maracaibo 24-IV-1981 H.K. Townes (1♂ AEIC).

## 24. *Iucastignus urqicus* Finnamore new species

*Derivation of Name.*—The name is derived the Quichuan *urqo*, meaning hill; and the Geerk *ikos*, meaning belonging to, in reference to the type locality in the hilly country of Minas Gerais, Brasil.

*Diagnosis.*—This species is one of those with a reduced median scutal groove that is confined to the posterior part of the scutum and does not reach the admedian lines. Unlike other species with a reduced scutal groove it has a white, toothed pronotal lobe in the male, and, in the female a toothed, brown pronotal lobe, black mesosoma, and the absence of lateral clypeal teeth. Although this species is known from only 2 specimens and might appear to be conspecific with either *chiucha* or *mauracis*, the lack of a lateral tooth on the female clypeal margin is a substantial difference from either of those species.

*Male.*—Length 3.5 mm. **HEAD.** Flagellomeres without tyli or specialized setae; flagellomere I length  $1.7 \times$  apical width; flagellomere X length  $1.6 \times$  apical width; flagellomere XI straight, cylindrical, apex conical. Clypeus obscured by dense appressed setae which extend up frons along inner margins of eyes to approximately twice the height of antennal socket. Frons uniformly microsculptured with punctures obscure; vertex more shiny, weakly microsculptured, punctures sparse, 3 or more diameters apart; gena microsculptured, more strongly so than vertex; genal punctures sparse, obscure; gena without ventral tooth or swelling; micropore field present as a small, oval patch between compound eye and lateral ocellus, without depression behind it; lateral ocelli closer to each other than to compound eyes. **OOD**  $1.6 \times$  **LOD**. **MESOSOMA.** Transverse pronotal carina forming a right angle at humeral angle and toothed or produced ventrally, transverse pronotal groove with longitudinal striae; pronotal lobe weakly toothed, with weak anterior carina; lateral

pronotal area with several longitudinal striae. Scutum microsculptured anteriorly, posterior half more shiny, with weak microsculpture, and with strong punctures that are about 2 diameters apart; notauli present anteriorly, attenuated posteriorly near scutal midlength; median scutal groove present posteriorly, attenuated near scutal midlength and not reaching admedian lines; posterior scutal margin with a series of short ridges parallel to median groove. Scutellum weakly microsculptured, with several obscure median punctures and a longitudinal sulcus. Pre-auricular area with sculpture plainly visible and setae obscure. Mesopleuron with hypersternaulus, scrobal sulcus, and omaulus coarsely foveolate; mesopleuron otherwise shiny and microsculpture weak, mostly impunctate. Metapleuron dull, microsculptured with several irregular longitudinal ridges. Propodeum dull, microsculptured over most of surface and coarsely areolate; propodeal enclosure not differentiated from lateral spheres; basolateral propodeal area adjacent to metapleuron shiny, unsculptured. METASOMA. Tergum I shiny, without microsculpture; tergal punctures small, obscure, not readily evident; sterna shiny, microsculpture weak and punctures sparse, not increasing in density towards posterior sterna. COLOR. Black. White: palpi, and pronotal lobe. Yellow-brown: mandible, except apex; antenna, except flagellomere XI; tegula; fore leg; mid leg; hind trochanter, hind tibia and hind tarsus.

*Female*.—Length 5 mm. Similar to male except as follows: flagellomere I length  $1.8 \times$  apical width; clypeus shiny, setae and punctures sparse, the latter about 2 diameters apart medially; median clypeal lobe with 2 teeth separated by a narrow U-shaped emargination, long setae arise from subapical pit on each tooth; apical clypeal margin without lateral teeth. Frons along inner eye margin not obscured by appressed setae; punctures of vertex and gena stronger than those of male, 2 or

more diameters apart.  $OOD\ 2.2 \times LOD$ . Scutum with some tendency toward ridged, striatopunctate sculpture anterolaterally, posteriorly, and medially. Color as in male, except pronotal lobes brown.

*Material Examined*.—1 ♂, 1 ♀. HOLOTYPE FEMALE: Brazil: Serra do Caraca, S. Barbara, M. Ger. 1600m II-1969 F.M. Oliveira (AEIC). Paratype: BRAZIL: Bahia: Itabuna CEPEC XI-1978 F.P. Benton, Mucuri (1♂ BMNH).

### 25. *Incastigmus zephyrus* Finnamore new species

*Derivation of Name*.—The name is derived from the Latin *Zephyrus*, meaning a west wind.

*Diagnosis*.—The reduction of the median scutal groove to an elongate pit on the posterior scutal margin, yellow to red pronotal lobe, and the pronotum with a tooth on the transverse carina at the humeral angle that is larger than the tooth on the vertical carina, suffice to distinguish males and females of this species. In addition, the female is distinguished from the similar *mystaxalbus*, by its black clypeus (*mystaxalbus* has the apical third of its clypeus white and the transverse pronotal carina slightly obtuse at the humeral angle).

*Male*.—Length 3.5–4.0 mm. HEAD. Flagellomeres without tyli or specialized setae; flagellomere I length  $1.56 \times$  apical width; flagellomere X length  $1.3 \times$  apical width; flagellomere XI straight, cylindrical, apex conical. Clypeus obscured by dense appressed setae that extend up frons along inner eye margin to about half height of scape. Frons uniformly microsculptured without punctures except on upper area; vertex more shiny, weakly microsculptured, with punctures small and sparse, 3–5 diameters apart. Genal microsculpture and punctation similar to that of vertex; gena without ventral tooth or swelling. Micropore field a small diffuse circle between lateral ocellus and compound eye, without depression behind it.

Lateral ocelli closer to each other than to compound eye; OOD  $1.6 \times$  LOD. MESOSOMA. Transverse pronotal carina toothed at humeral angle and with a smaller, ventral blunt tooth; transverse pronotal groove longitudinally striate; pronotal lobe rounded; lateral pronotal area longitudinally striate. Scutum microsculptured with punctures 3 or more diameters apart; notauli attenuated near anterior third of scutum; median scutal groove reduced to an elongate pit on posterior scutal margin, the latter with several short, evanescent, longitudinal ridges on each side of the midline. Scutellum weakly microsculptured on anterior  $2/3$  and with several mediolateral punctures. Preomalar area with sculpture plainly visible and setae absent. Mesopleuron with hypersternaulus, scrobal sulcus, and omaulus coarsely foveolate; mesopleuron obscurely punctate, otherwise shiny with weak microsculpture. Metapleuron dull, microsculptured, and without ridges. Propodeum shiny and coarsely areolate, enclosure not differentiated from lateral spheres, basolateral propodeal area adjacent to metapleuron shiny with irregular microstriae. METASOMA. Tergum I shiny, without microsculpture; tergal punctures sparse, irregular, a few to many diameters apart and increasing in strength on more posterior terga. Sterna shiny, microsculpture weak; sternal punctures of similar density on sterna beyond S2. COLOR. Black. White: palpi. Yellow-brown: mandible, except apex and base; antenna ventrally; pronotal lobe; tegula; fore trochanter; fore femur on base and apex, sometimes entirely; fore tibia and fore tarsus; mid trochanter; sometimes mid femur; mid tibia and mid tarsus; hind tibial base and apex, sometimes entirely; hind tarsus; metasomal tergum VII and sterna VI and VIII.

*Female*.—Length 3.5–4 mm. Similar to male except as follows: flagellomere 1 length  $2 \times$  apical width; clypeus shiny, setae and punctures sparse, the latter about 2 diameters apart medially; median clyp-

eal lobe with 2 teeth separated by a weak emargination, long setae arise from subapical pit on each tooth; apical clypeal margin without lateral teeth; frons along inner eye margin not obscured by appressed setae; upper frons, vertex and gena sometimes shiny, without microsculpture; OOD  $2.25 \times$  LOD; scutum sometimes shiny posteriorly and punctures stronger than in male; color as in male but legs generally darker (femora and tibiae often black) and in light forms parts of the pronotum, scutum, scutellum, and mesopleuron may be red-brown.

*Material Examined*.—5♂, 7♀. HOLOTYPE MALE: Guatemala: Jalapa 3km S. Jalapa, 12-13-IX-1987, 1300m Sharkey (CNCI). Paratypes: **COSTA RICA: Puntarenas**: San Vito, Las Alturas 1500m VIII-1991 Hanson & Godoy (1♀ MUCR). **San José**: Escazú 20-V-1987 H. & M. Townes (1♂ AEIC). **GUATEMALA: Chimaltenango**: Yepocapa 1-V-1948 H.T. Dalmat (1♀ USNM). **Jalapa**: 3km S. Jalapa 12-IX-1987 M. Sharkey 1400m (1♀ CNCI); 12-13-IX-1987 M. Sharkey 1300m (1♀ CNCI). **Sacatepequez**: Antigua X-1965 NLH Krauss (1♀ USNM); 30-V-1973 (2♂ PMAE). **MEXICO: Quintana Roo**: [Kohuniich Ruins] 30 mi E. [Chetmal] 15-VII-1983 R. Anderson, mix. cohune palm for. 350 ft. (1♀ PMAE). **NICARAGUA**: [Santo Maria de Ostuma] XI-1959 NLH Krauss (1♂ USNM). **PANAMA: Chiriqui**: Volcan 1-3-VI-1983 Mt, 1470m P.J. Spangler, R.A. Faitoute, W.E. Steiner (1♀ USNM).

#### LITERATURE CITED

- Ashmead, W.H. 1900. Report upon the aculeate Hymenoptera of the islands of St.Vincent and Grenada, with additions to the parasitic Hymenoptera and a list of the described Hymenoptera of the West Indies. *Transactions of the Entomological Society of London* 1900: 207–367.
- Bohart, R.M. and A.S. Menke. 1976. *Sphecid wasps of the world, a generic revision*. University of California Press, Berkeley, 695 pp.
- Finnamore, A.T. 1995. Revision of the world genera of the subtribe Stigmina (Hymenoptera: Apoidea: Sphecidae: Pemphredoninae), Part 1. *Journal of Hymenoptera Research* 4:204–284.

- Fox, W.J. 1897. Contributions to a knowledge of the Hymenoptera of Brazil, No. 3. Sphegidae (*Sens. Lat.*). *Proceedings of the Academy of Natural Sciences of Philadelphia* 373–388.
- Gittins, A.R. 1969. Revision of the Nearctic Psenini (Hymenoptera: Sphecidae) I. Redescriptions and keys to the genera and subgenera. *Transactions of the American Entomological Society* 95:49–76.
- Kohl, F.F. 1890. Zur Kenntniss der Pemphredonen. *Annalen des k. k. naturhistorischen Hofmuseums Wien* 5:49–65.
- Melo, G.A.R. 1999. Phylogenetic relationships and classification of the major lineages of Apoidea (Hymenoptera), with emphasis on the crabronid wasps. *Scientific Papers, Natural History Museum, The University of Kansas* 14:1–55.

## A Key to Genera and Subgenera of Mutillidae (Hymenoptera) in America North of Mexico with Description of a New Genus<sup>1</sup>

DONALD G. MANLEY AND JAMES P. PITTS

(DGM) Department of Entomology, Clemson University, Pee Dee Res. & Educ. Center, 2200 Pocket Rd., Florence, South Carolina 29506-9706; (JPP) Department of Entomology, The University of Georgia, 413 Biological Sciences Bldg., Athens, Georgia 30602-1603

---

*Abstract.*—The family Mutillidae in America north of Mexico is represented by 19 genera, including three of the seven world subfamilies. Five of these genera are further represented at the subgeneric level, giving a total of 27 taxa represented at the generic or subgeneric level. *Caenotilla* Pitts and Manley, new genus, is described and illustrated with its type species *choreocarina* Pitts and Manley, new species. This genus is based on females only and can be distinguished from other New World genera by the presence of a carina that delimits the pronotum from the mesonotum, presence of two carinae in the scutellar region (one being the scutellar scale), the shape of the thorax, the presence of plumose pubescence and the presence of carinae that laterally define the pygidial area. Mutillidae has remained poorly studied taxonomically and biologically for several reasons, one being marked sexual dimorphism. Consequently, many genera are known from only one sex. Of the 27 New World genera and subgenera, 12 are known by only one sex. A further impediment to advancement of mutillid taxonomy is the lack of a key to the genera. Presented here is a key to the genera and subgenera of Mutillidae in America north of Mexico, and generic diagnoses are given.

---

The family Mutillidae is found worldwide, but is predominantly tropical. It contains approximately 8,000 species (Brothers 1975). The genus *Mutilla* was first described in 1758 by Linnaeus. Since then, approximately 230 genera and subgenera have been described worldwide. Brothers (1975) investigated the phylogeny of Mutillidae and recognized seven monophyletic subfamilies. Lelej and Nemkov (1997) proposed a new phylogeny which included 10 subfamilies. Since that phylogeny has not been generally accepted, here we follow the nomenclature of Brothers (1975) and Schuster (1958) throughout.

The Mutillidae fauna of America north of Mexico includes only three subfamilies

(Myrmosinae, Sphaerophthalminae, and Mutillinae) represented by 19 genera, of which five are further divided into subgenera. Sphaerophthalminae is represented by the tribe Sphaerophthalmini (Pseudomethocina and Sphaerophthalmina). Mutillinae is represented by both Mutillini (Smicromyrmina) and Ephutini.

In a study of Mutillidae from the southwestern United States, seven specimens of an undescribed species were found. Although no phylogenetic hypothesis is available for genera of Sphaerophthalminae, this new species has several features that are typically considered to be of generic level importance for Sphaerophthalminae. This genus and new species are described, illustrated and discussed below.

Mutillidae has remained poorly studied taxonomically and biologically for a couple of reasons (Brothers 1975). One is that sexual dimorphism within the family is

---

<sup>1</sup> Technical contribution no. 4532 of the South Carolina Agricultural Experiment Station, Clemson University

typically very marked. Color patterns and often overall body size of the two sexes can be quite different (Brothers 1989). Certain genera practice phoretic copulation (e.g., *Timulla* Ashmead and *Ephuta* Say), in which the sexes remain *in copula* during flight. In these genera, males are usually much larger than females.

All female mutillids are apterous. Males are usually macropterous. However, reduction in wing size is known in four genera of Mutillidae. Males of *Myrmilloides grandiceps* (Blake), *Stethophotopsis maculata* Pitts and *Sphaerophthalma* (*Micromutilla*) *brachyptera* Schuster are brachypterous. Males of *Morsynna ashmeadii* Fox are apterous. All known species with reduced wings are found in the southwestern United States. Males of other species from this same region, such as *Sphaerophthalma* (*Photopsis*) *unicolor* (Cresson) (Schuster 1958; Manley unpublished data) and *Odontophotopsis melicausa melicausa* (Blake) (Pitts unpublished data), have been known to chew their wings off.

Due to extreme sexual dimorphism, sex associations can be made only by catching pairs *in copula* or through the use of caged females (Manley 1999). Host data or, in certain cases, the use of geographical data, can also be used to associate the sexes. Association of sexes is further complicated by the fact that, in certain species, males and females utilize different hosts (Matthews 1997). Consequently, many genera are known from only one sex. Of the 27 New World taxa at either the generic or subgeneric level, 12 are represented by only one sex (Krombein et al. 1979; Nonveiller 1990).

A further impediment to advancement of mutillid taxonomy is the lack of a key to the genera. Without a generic key for a large geographic region, the few (and terribly outdated) keys to the species of some genera (Krombein 1939; Mickel 1928, 1935, 1936a, 1937, 1940; Schuster 1949, 1951) have limited application. The key to the genera and subgenera of the Nearctic re-

gion that is provided here is an attempt to rectify this problem.

It is desirable to have a key to all genera worldwide, or to the New World, or at least to include all of North America. However, even to include Mexico, many more genera [most of which are represented by only one or two species and contain several synonyms (Pitts unpublished data)] would have to be added (Nonveiller 1990). As a beginning, we include only those genera and subgenera found in America north of Mexico.

Note that in the key, where fauna are indicated for each taxon, the number of species listed includes those for which only the male is known, only the female is known, and for which both sexes are known. Hence, 1 sp. ♂, 1 sp. ♀, and 1 sp. ♂ ♀ means that three species are known for that taxon. It is important to include this information to avoid concluding that all species are represented by both sexes.

## MATERIALS AND METHODS

The abbreviations T2, T3, etc., denote the second, third, etc., metasomal tergites, respectively. Similarly, S2, S3, etc., signifies the second, third, etc., metasomal sternites, respectively. After Ferguson (1967), we are adopting the following notation for punctuation, in order of decreasing coarseness: reticulate, coarse, moderate, small, fine and micropunctate. Micropunctate refers to punctures that are extremely shallow, and do not have vertical walls or sharp margins. We have used the term simple pubescence for setae that are smooth and do not have barbed surfaces. Brachyplumose pubescence refers to setae with barbs that are less than or equal to the diameter of the shaft at the attachment of the barb. Plumose pubescence is used for setae that have longer barbs.

### *Caenotilla* Pitts and Manley, new genus

*Female*.—*Head*: Wide as thorax. Eyes polished and oval, not protuberant (Fig.

1). Clypeal base tuberculate, anterior margin broad. Antennal tubercles well developed and subcontiguous, connected dorsally by a carina. Antenna with 12 segments. Mandible bidentate apically, ventral with a distinct sub-basal tooth. Antennal scrobe carinate above. Gena well developed, lacking genal carina. Proboscis furrows triangular, broad, reaching to mandibular base, postero-laterally margined by a carina. Maxillary palpus 6-segmented and labial palpus 4-segmented. *Mesosoma*: Dorsum short, flat, pyriform (Figs. 2, 4). Pronotum separated from mesonotum by fine carina that extends sinusously to tegular region (Figs. 2, 4, 5). Humerus with angulate carina. Scutellar and second scale present (Figs. 2, 4, 6). Propodeum with separation between anterior, posterior and lateral regions. Propleuron narrow, punctate. Mesopleuron punctate medially, anteriorly and posteriorly glabrous, impunctate. Metapleuron glabrous, impunctate. Metapleuron separate from mesopleuron by complete carina. Femora of all legs claviform; spurs of all tibiae pectinate. *Metasoma*: T1 sessile with T2. Felt line present on T2 (Fig. 8). S2 lacking felt line (Fig. 8). Pygidial area defined laterally by carinae (Fig. 8). Brachyplumose and plumose pubescence present on apical margins of metasomal tergites (Figs. 9, 10).

*Male*.—Unknown.

*Etymology*.—From the Greek *caen* for "new" + *tilla*, a commonly used suffix. The name *Caenotilla* refers to the fact that the genus is newly founded. Gender feminine.

*Distribution*.—Napa County, San Luis Obispo County, and Nevada County in Southern California.

*Type species*.—*Caenotilla choreocarina*, sp. nov.

***Caenotilla choreocarina* Pitts and  
Manley, new species  
Figs. 1–10**

*Female holotype*.—*Coloration*: Head, thorax, T1, and S1 dark red. Metasomal seg-

ments 2–6 dark brown. Mandibles dark red, tips black. Flagellum and legs black. Occiput and pronotum with white pubescence. Brachyplumose pubescence reddish brown on vertex of head and dorsum of thorax, stout, erect; also with thicker decumbent brachyplumose pubescence (Fig. 1, inset). Scape and clypeus with white brachyplumose pubescence. T1 with white plumose pubescence; T2 with dark brown brachyplumose pubescence; T3–T6 with golden brown erect brachyplumose pubescence and decumbent plumose pubescence. Apical fringe of T1, T2 and S2 pale plumose pubescence (Figs. 8–10). Legs with white brachyplumose pubescence. *Head*: Clypeus with posterior border distinctly dentate, with circular depression laterally and below antennal scape, median anterior region and lateral regions, with long pale setae. First flagellomere longer than pedicel and as long as second flagellomere (Fig. 7). Terminal flagellomere longer than preceding segment, with apex obtusely angular. Gena with small punctation. Gena subequal to maximum length of eye. Punctation small (Fig. 1, inset). *Mesosoma*: Disk of pronotum and mesonotum punctate (Fig. 4–6). Humerus with angulate carina. Fine carina delimits pronotum from mesonotum (Figs. 2, 4, 5). Propodeal spiracle tuberculate (Figs. 2, 4). Dorsal face of propodeum punctate (Fig. 4). Propodeum weakly reticulate anteriorly and laterally. Posterior of propodeum impunctate medially. Propleura punctate. Mesopleura punctate medially with long, fuscous pubescence; anteriorly and posteriorly impunctate and nitid. Posterolateral region of propodeum punctate, with long pubescence. Legs with dense fuscous pubescence. *Metasoma*: T1–T2 sparsely punctate, with sparse erect pubescence (Fig. 8). T3–T6 with larger punctation and denser pubescence (Fig. 8). S1 with median elevated carina that is notched medially. S2–S6 with sparse punctation, last with apex weakly truncate. Pygidium weakly longi-

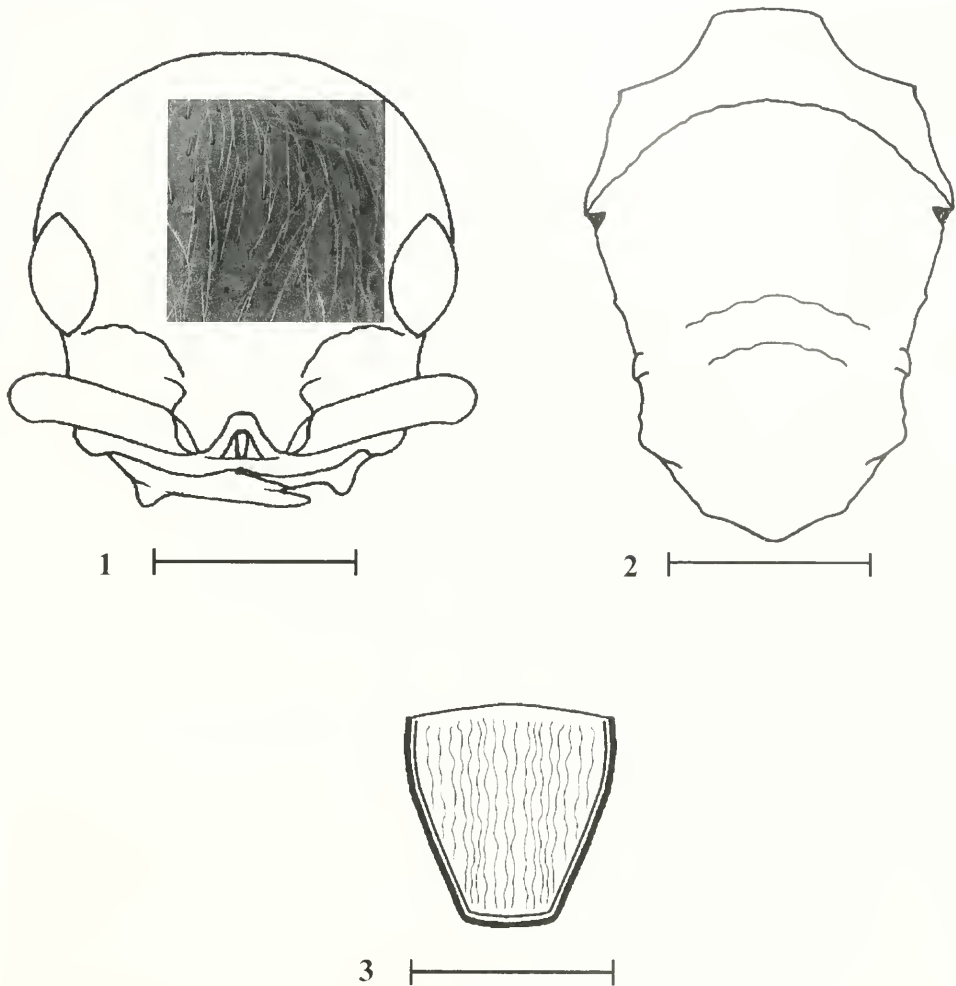

Figs. 1-3. *Caenotilla choreocarina*. 1, Head, frontal view, sculpture and pilosity inset from SEM; 2, Thorax, dorsal view, sculpture of dorsum and pilosity omitted; 3, Pygidium. [Line indicators equal 0.50 mm, 0.75 mm, and 0.30 mm respectively.]

tudinally rugose, defined laterally by carinae (Fig. 3). Punctuation fine.

*Length*.—4 mm.

*Male*.—Unknown.

*Holotype*.—California, Nevada County, Sagehen Creek, 1920m, 1 ♀, 9-12.VII.1992, Coll. P. S. Ward (University of California, Davis, California). The holotype was collected from the ground in a small clearing. The clearing was in lodgepole pine forest, opposite the spring which supplies Sagehen Creek Field Station with water (personal communication, P. S. Ward).

*Other material examined*.—Paratypes: California, San Luis Obispo County, Pozo, 2 ♀, 27.IV.1962, 1 ♀, 30.IV.1962, 2 ♀, 4.V.1962, Coll. J. Powell (United States National Museum and James P. Pitts, personal collection); California, 1 ♀ "Napa Co. Coll. Coquillett" (USNM); California, Yolo County, 600m, 18.5 km ESE Lower Lake, 1 ♀, 15.V-9.VI.1993, Coll. B. T. Fisher (UCDC).

*Distribution*.—California.

*Biology*.—Unknown.

*Hosts*.—Attached to one specimen is a

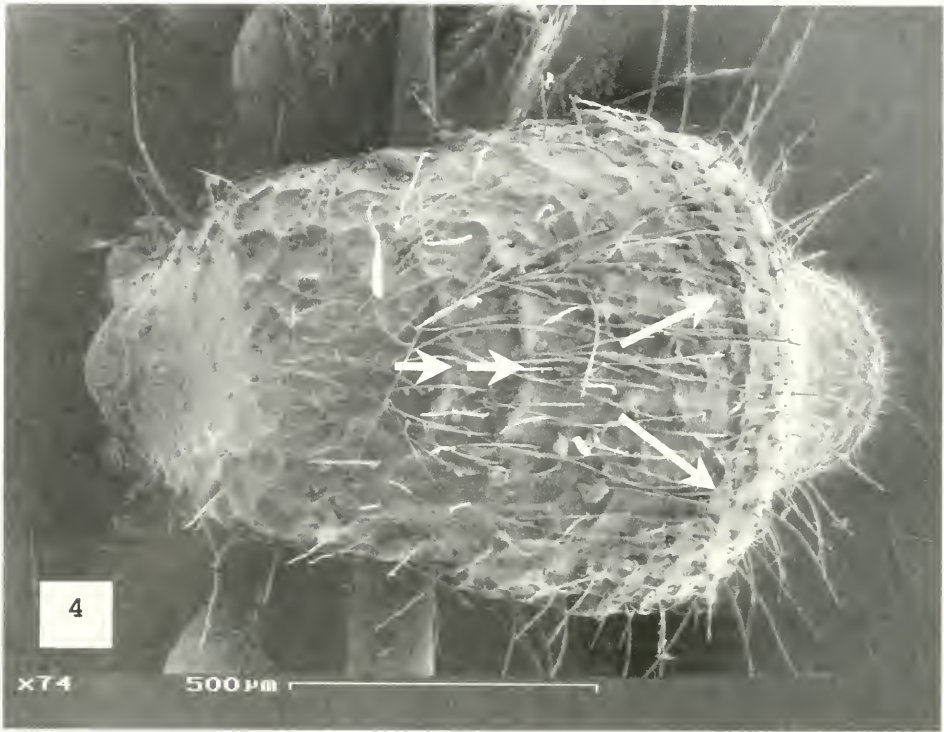

Figs. 4-5. *Caenotilla choreocarina*. 4, Thorax, dorsal view, arrows point to the scutellar carinae and pronotal carina; 5, Pronotum, dorsal view, arrow points to the pronotal carina.

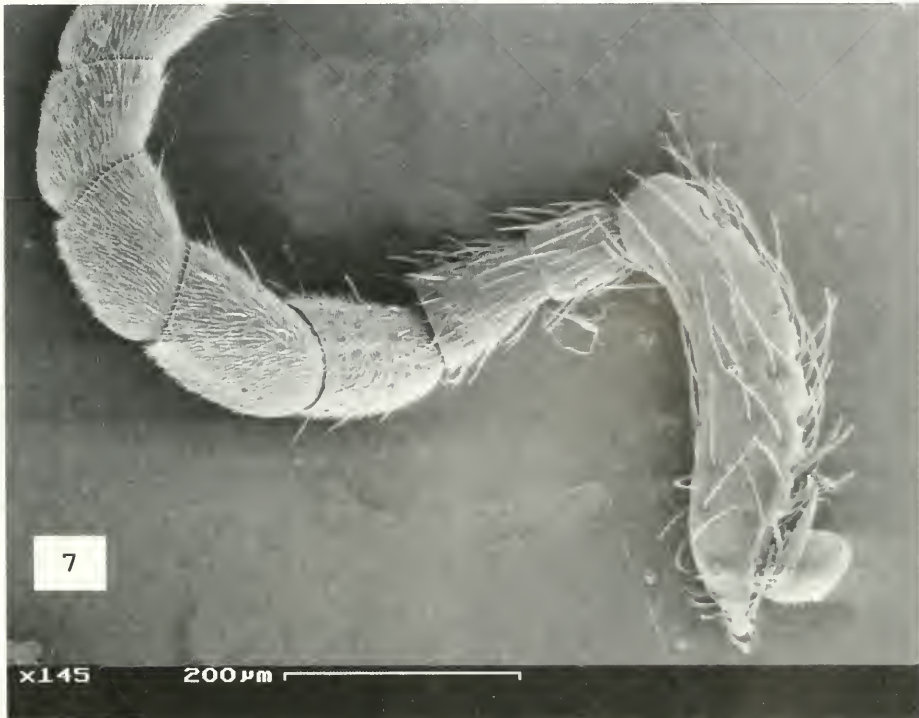
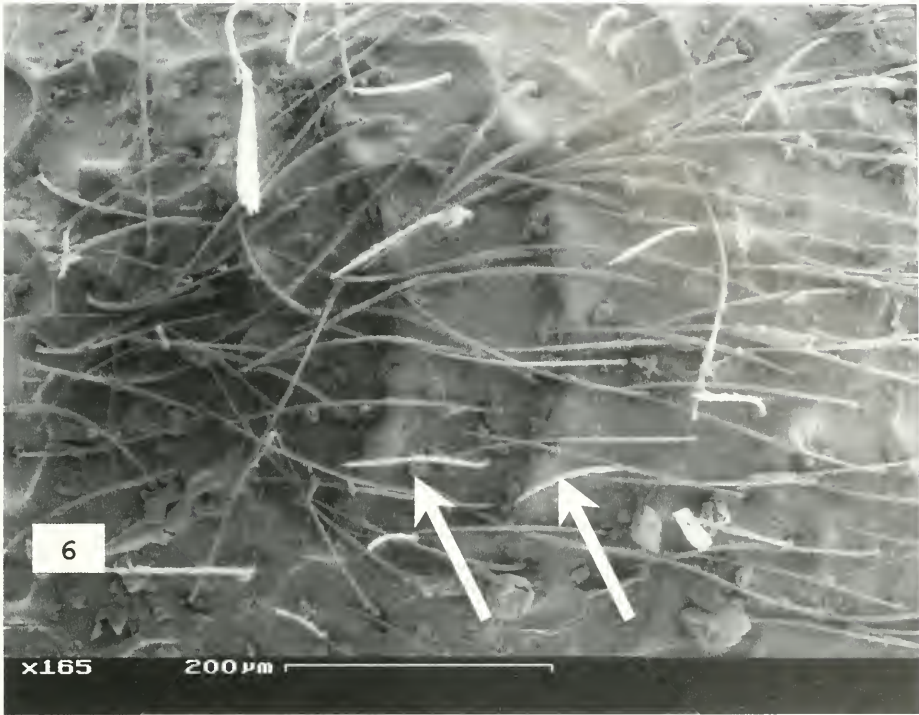

Figs. 6-7. *Caenotilla choreocarina*. 6, Meso- and metanotum, dorsal view, arrows point to the scutellar carinae; 7, Antenna.

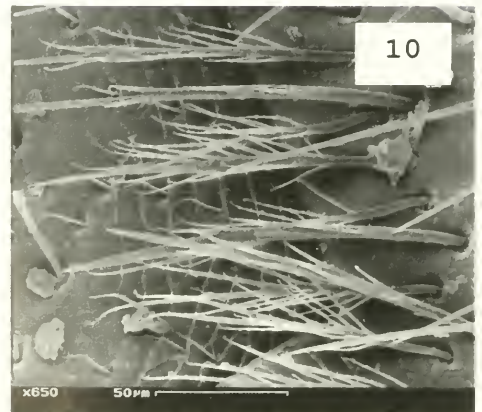
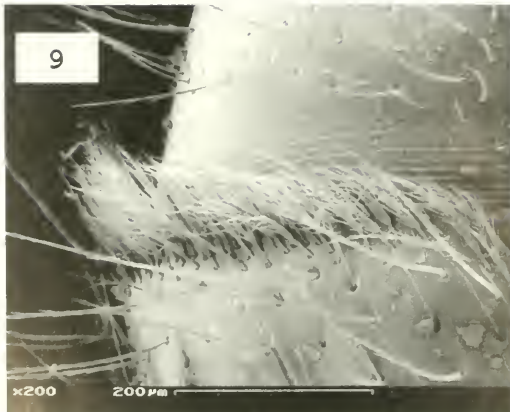

Figs. 8–10. *Caenotilla choreocarina*. 8, Abdomen, lateral view; 9, Apical margin of second metasomal segment, lateral view; 10, Plumose pubescence of apical margin of second metasomal segment.

hand written label reading "associated with *Xylocelia occidentalis*." *Xylocelia occidentalis* is now known as *Diodontus occidentalis* (Hymenoptera: Pemphredonidae) (Krombein et al. 1979). *Diodontus occidentalis* is known to be a host for *Omalus cressoni* (Aaron) (Hymenoptera: Chrysididae) and the mutillid, *Smicromutilla powelli* Mickel (Krombein et al. 1979). Within the genus *Diodontus*, only one other species is known to be parasitized; *D. virginianus* is a host of *Omalus intermedius* (Aaron) (Krombein et al. 1979). Although *D. occidentalis* is a known host of one species of mutillid, there is no cocoon nor rearing data associated with the specimen, and without more equivocal proof, this host association must remain questionable.

*Etymology*.—From the Greek *chore*, "dancing," and the Latin *carina*, "keel," in reference to the carina delimiting the pronotum and mesonotum.

*Variation*.—The specimens are very similar except that there is a moderate size variation. Most of the specimens are between 3 mm and 4 mm, with 2 specimens larger (5–6 mm). The size variation is due, in most cases, to variation in the size of the host or due to using different sized hosts (Brothers 1989). Smaller specimens of nocturnal mutillids have reduced infuscation and the coarseness of the integumental sculpturing is considerably reduced (Ferguson 1967). Although the specimens range in size from 3 mm to 6 mm, the development of the scutellar scale and the pronotal carina is very apparent in all specimens.

*Discussion*.—*Caenotilla* is a distinct genus of Sphaerophthalminae, Subtribe: Sphaerophthalmini. Sphaerophthalmini is distinguished by two synapomorphies for both sexes: the eye is approximately hemispherical, smooth and polished, and plumose pubescence is present (Brothers 1975). *Caenotilla* is immediately distinguished from all other genera of Mutillidae by the carina that delimits the pronotum from the mesonotum, the two cari-

nae (or scales) in the scutellar region, the pyriform shape of the thorax, the presence of plumose pubescence and a laterally defined pygidial area. *Caenotilla* can be determined to the subfamily Sphaerophthalminae without difficulty using keys to mutillid subfamilies (Brothers 1993, 1995).

At present, the male of *Caenotilla* remains unknown. The monotypic male genus *Morsyma* Fox may be the male of *Caenotilla*. *Caenotilla choreocarina* and *Morsyma ashmeadii* Fox have similar coloration and distribution. However, this is not enough information with which to make a sex association. *Caenotilla* could also be the female of *Acrophotopsis* Schuster or *Acanthophotopsis* Schuster. The possibility also exists that the male is undescribed and is as rare as the female. Because more evidence is necessary for a sex association to be made, the new species is placed in a new genus.

*Caenotilla* shares with *Protophotopsis* Schuster (Cambra and Quintero 1997) and *Nanotopsis* Schuster (Casal 1970) a sessile abdomen and lack of a genal carina. It also shares with *Protophotopsis* mandibles that are bidentate distally, integument of the head and thorax punctate, the anterior margin of the clypeus without teeth and the proboscis fossa extending to the base of the mandibles. *Caenotilla*, however, has the pygidial area defined laterally, the antennal scrobes with a dorsal carina, plumose pubescence present on the abdomen, and eyes more oval and not protruding.

*Caenotilla* shares with *Bordontilla* Fritz and Martinez (1975) a carina that is present on the dorsum of the thorax which delimits the pronotum from the mesonotum. *Caenotilla* can be distinguished from *Bordontilla* not only by the characters listed above but also by the fact that the clypeal tubercle is not as developed as in *Bordontilla*.

*Caenotilla* shares with *Photomorplus* Viereck oval shaped eyes, a defined pygidial area, a sessile abdomen and punctate dorsum. The shape of the thorax, the pygidial

area being longitudinally rugose and not striate, the plumose pubescence, the carina that delimits the pronotum from the mesonotum and, in some cases, the smaller size of the eyes separate *Caenotilla* from *Photomorplus*.

---

KEY TO GENERA AND SUBGENERA OF MUTILLIDAE IN AMERICA NORTH OF MEXICO

1. Females; meso- and metathorax fused, mesosoma at most two segmented; metasoma with 6 visible terga; antennae with 10 flagellomeres; wings absent ..... 2  
 – Males; meso- and metathorax not fused, mesosoma three segmented; metasoma with 7 visible terga; antennae with 11 flagellomeres; wings usually present ..... 22
2. (1) Pronotum and mesonotum not fused (Fig. 13); hind coxa with dorsal lamella (Fig. 14); felt line on lateral margin of tergite II absent (Fig. 16) (subfamily Myrmosinae) ..... 3  
 – Pronotum and mesonotum fused (Fig. 11); hind coxa without dorsal lamella (Fig. 12); felt line on lateral margin of tergite II present (except absent in *Ephuta*) ..... 5
3. (2) Clypeus with median spine or tooth; sternite I with median process near base (Fig. 16); punctation and sculpture conspicuous; ocelli usually present (Fig. 15) ..... *Myrmosa* (*Myrmosa*)  
**Key:** Krombein 1939. **Fauna:** 2 spp. ♀, and 2 spp. ♂♀.  
 – Clypeus simple, lacking median spine or tooth; sternite I simple, lacking median process near base; relatively smooth, lacking conspicuous punctation and sculpture; ocelli absent ..... 4
4. (3) Mandible with two apical teeth; ventral mandibular lamella present; prothoracic tarsus without rake (Fig. 17) ..... *Myrmosula*  
**Key:** Wasbauer 1973. **Fauna:** 1 sp. ♂, 6 spp. ♀, and 1 sp. ♂ ♀.  
 – Mandible with large apical tooth and two very small teeth on inner margin; ventral mandibular lamella absent; prothoracic tarsus with rake consisting of long, spatulate spines at outer apex of each segment (Fig. 18) ..... *Leiomyrmosa*  
**Fauna:** 1 sp. ♀.
5. (2) Metasomal segment I completely sessile with second (Fig. 10) ..... 6  
 – Metasoma petiolate or at most subsessile, with definite constriction between first two segments (Fig. 21) ..... 13
6. (5) Eyes strongly ovate; mesosoma long, rectangular, generally narrowed medially (Fig. 27); tergite II generally maculated with two spots or lines of pale setae (subfamily Mutillinae, tribe Mutillini) ..... *Timulla*  
**Key:** Mickel 1937. **Fauna:** 13 spp. ♂, 6 spp. ♀, and 11 spp. ♂ ♀.  
 – Eyes circular to slightly ovate; mesosoma otherwise (short, rectangular or narrowed posteriorly, if narrowed medially, mesosoma pyriform not rectangular); tergite II not maculated with spots of pale setae ..... 7
7. (6) Head quadrate, larger than mesosoma in dorsal view; eyes circular (if eyes slightly ovate, head distinctly wider than mesosoma); mesosoma narrowed medially (subfamily Sphaerophthalminae, tribe Sphaerophthalmini, subtribe Pseudomethocina) (Figs. 22, 24, 26) ..... 8  
 – Mesosoma as wide or wider than head in dorsal view; eyes slightly ovate; mesosoma narrowed posteriorly (Figs. 23, 27–29) (subfamily Sphaerophthalminae, tribe Sphaerophthalmini, subtribe Sphaerophthalmina, in part) ..... 9
- 

→

Figs. 11–21. 11–12, Sphaerophthalminae. 11, Mesosoma; 12, Coxa. 13–16, Myrmosinae. 13, Mesosoma; 14, Coxa; 15–16, *Myrmosa* sp. 15, Dorsal view; 16, Lateral view. 17, *Myrmosula* sp. prothoracic leg. 18, *Leiomyrmosa* sp. prothoracic leg. 19, *Protophotopsis* sp. metasoma. 20, Sessile metasoma. 21, Petiolate metasoma.

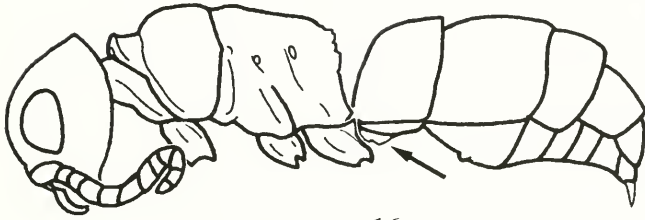
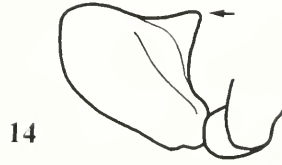
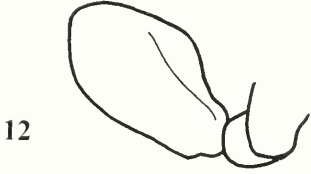
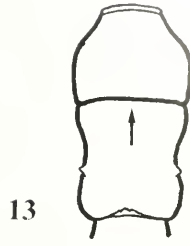
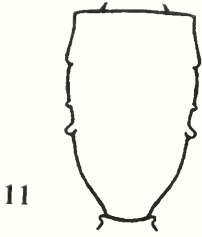

16

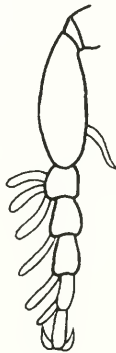

17

18

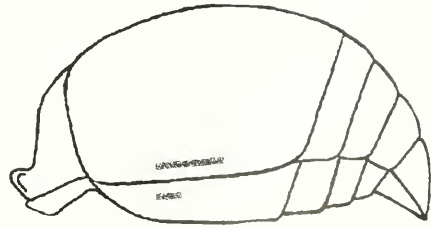

19

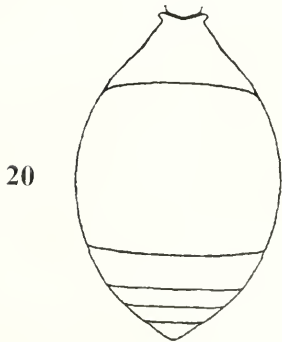

20

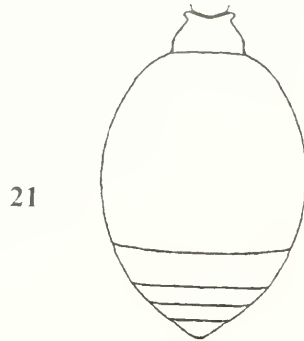

21

8. (7) Hypostomal teeth prominent (Fig. 25, hst), bent outward apically; posterolateral angles of head strongly carinate and dentiform (Fig. 25, pah); head, in dorsal view, about twice width of mesosoma (Fig. 24); pygidium lacking lateral carinae ..... *Myrmilloides*  
**Fauna:** 1 sp. ♂ ♀
- Hypostomal teeth (if present) not prominent, not bent apically; posterolateral angles of head not dentiform, usually not strongly carinate; head, in dorsal view, less than twice width of mesosoma (Fig. 26); pygidium usually with lateral carinae ..... *Pseudomethoca*  
**Key:** Mickel 1935. **Fauna:** 7 spp. ♂, 18 spp. ♀, and 17 spp. ♂ ♀.
9. (7) Pygidium undefined laterally; humera angulate; sternal felt line present, although may be inconspicuous; plumose setae absent (Fig. 19) [The subgenus *Sphaerophthalma* s.s. may key here due to erroneous evaluation of the subsessile condition of the petiole. It differs from *Protophotopsis* in having the mandible toothed beneath and plumose setae among other differences (see diagnoses)] ..... *Protophotopsis*  
**Key:** Cambra and Quintero 1997. **Fauna:** 1 sp. ♂ ♀.
- Pygidium defined laterally; sternal felt line absent; plumose setae present or absent ..... 10
10. (9) Mesosoma with fine carina between pronotum and mesonotum; scutellar scale and carina immediately anterior to scale present; pygidium longitudinally rugose ..... *Caenotilla*  
**Fauna:** 1 sp. ♀.
- Mesosoma without fine carina between pronotum and mesonotum; scutellar scale and carina immediately anterior to scale absent; pygidium variable ..... 11
11. (10) Mesosoma narrowed posteriorly (Fig. 28); mandible ventrally emarginate, but not toothed; integument densely covered with simple appressed setae; plumose setae present on anterior margin of mesosoma, propodeum, petiole, and apical margins of tergites ..... *Sphaerophthalma* (*Photopsis*) (in part)  
**Key:** Schuster 1958. **Fauna:** 41 spp. ♂, 21 spp. ♀, and 2 spp. ♂ ♀.
- Mesosoma rectangular (Fig. 29); mandible ventrally toothed or not; integument visible, usually sparsely covered with appressed and erect simple setae ..... *(Photomorphus)* 12
12. (11) Pygidium dull, shagreened, with parallel carinae only on basal two-thirds or less ..... *Photomorphus* (*Photomorphina*)  
**Key:** Krombein 1954. **Fauna:** 26 spp. ♂, 1 sp. ♀, and 1 sp. ♂ ♀.
- Pygidium smooth and shiny, with complete parallel carinae on disk ..... *Photomorphus* (*Photomorphus*)  
**Key:** Krombein 1954. **Fauna:** 4 spp. ♂, 1 sp. ♀, and 2 spp. ♂ ♀.
13. (5) Felt lines absent on metasomal tergite II; petiole short, transverse, parallel-sided (Fig. 30); eyes distinctly ovate; a band of silvery, dense, sericeous vestiture present at apex of petiole and metasomal segment II; small; densely punctate (subfamily Mutillinae, tribe Ephutini) ..... *Ephuta*  
**Key:** Schuster 1951, 1956. **Fauna:** 13 spp. ♂, 9 spp. ♀, and 6 spp. ♂ ♀.
- Felt lines present on metasomal tergite II; petiole not transverse or parallel sided; eyes circular to slightly ovate; other characters variable (subfamily Sphaerophthalminae, tribe Sphaerophthalmini, subtribe Sphaerophthalmina, in part) ..... 14
14. (13) Plumose setae present on apical margin of metasomal tergite I (at least medially on apical margin of metasomal tergite I), sometimes present on apical margins of all metasomal tergites and/or covering the tergites ..... 15
- Plumose setae totally absent ..... 20
15. (14) Pygidial area defined laterally by carinae (Fig. 32) ..... 16
- Pygidial area undefined laterally by carinae ..... 17
16. (15) Antennal scrobes not distinctly carinate above; pygidial area granulate; plumose setae

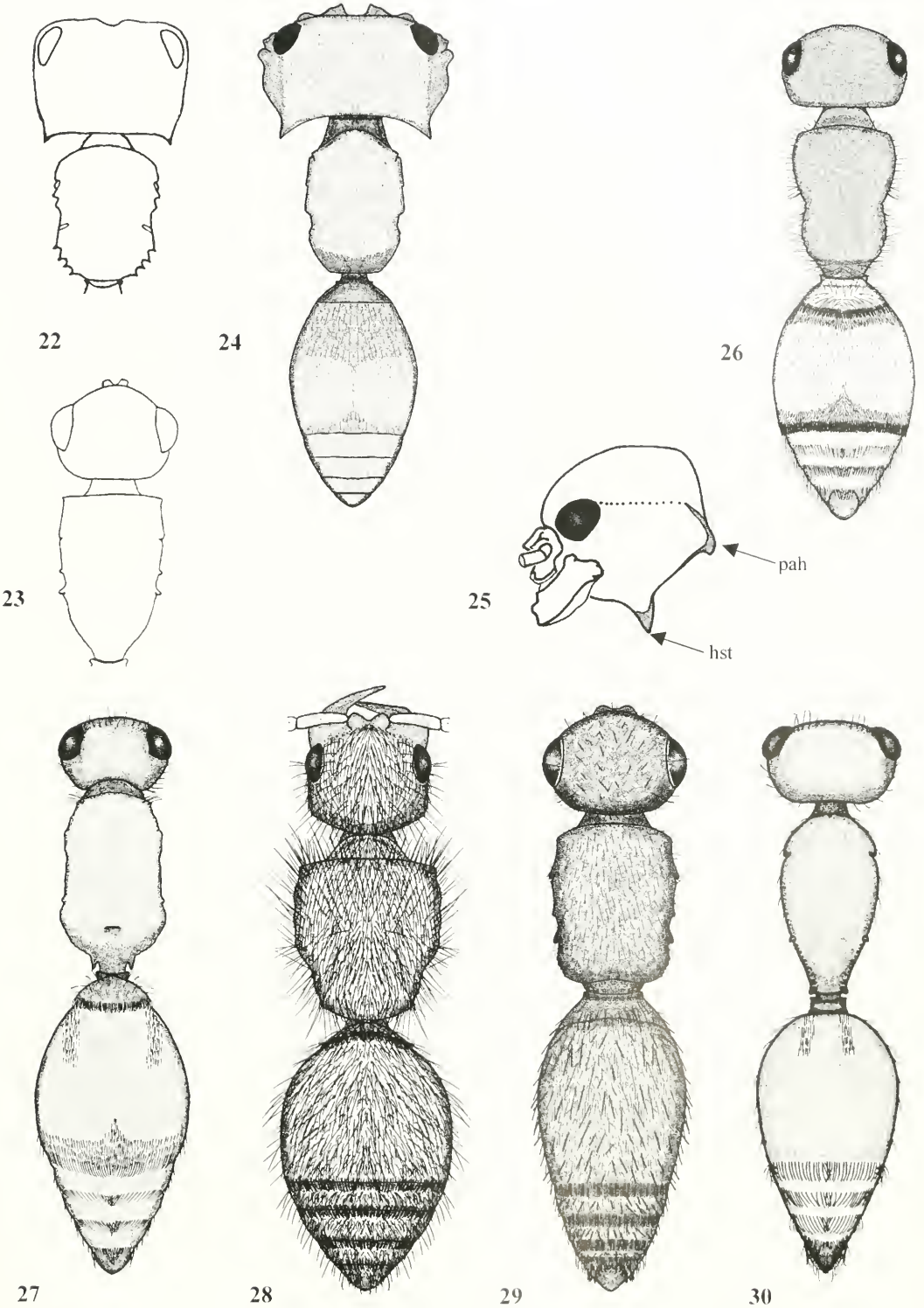

Figs. 22–30. 22, *Pseudomethocina*. 23, *Sphaerophthalmina*. 24–25, *Myrmilloides grandiceps*. 24, Dorsal view; 25, Head (hst, hypostomal tooth; pah, posterior angle of head). 26, *Pseudomethoca simillima*, dorsal view. 27, *Timulla* sp. 28, *Sphaerophthalma* (*Photopsis*) sp. 29, *Photomorphus* sp. 30, *Ephluta* sp., dorsal view.

- limited to posterior margin of head, anterior margin of mesosoma, and posterior margins of metasomal segments; dorsum of mesosoma and disk of tergite II with appressed golden setae ..... *Dilophotopsis*  
**Fauna:** 1 spp. ♂, and 1 sp. ♂ ♀; North America. **Taxonomy:** Mickel 1963.
- Antennal scrobes distinctly carinate above; pygidial area sculpture variable, usually rugosely sculptured; plumose setae elsewhere or completely covering body; setae of dorsum of mesosoma and disk of tergite II variable .....  
 ..... *Sphaerophthalma (Photopsis)* (in part)  
**Fauna:** 41 spp. ♂, 21 spp. ♀, and 2 spp. ♂ ♀.
17. (15) Genal carina present ..... *Sphaerophthalma (Photopsis)* (in part)  
**Fauna:** 41 spp. ♂, 21 spp. ♀, and 2 spp. ♂ ♀.
- Genal carina absent ..... 18
18. (17) Flagellomere II less than 1.2x length of first; antennal scrobe not distinctly carinate dorsally; height of anterior face of metasomal segment II (Fig. 33, af) greater than 0.75x maximum height of metasomal segment I ..... *Stethophotopsis*  
**Fauna:** 1 sp. ♀, 1 sp. ♂ ♀.
- Flagellomere II greater than 1.75x length of first; antennal scrobe distinctly carinate dorsally; height of anterior face of metasomal tergite II (Fig. 36, af) less than 0.25x maximum height of metasomal segment I ..... 19
19. (18) Plumose setae limited to area of short dense white setae on dorsum of petiole, and apical fringe of tergite II (Fig. 31); propodeum elongate, length in lateral view equal to 0.75x height; first metasomal segment subsessile with second .....  
 ..... *Sphaerophthalma (Sphaerophthalma)*  
**Fauna:** 1 sp. ♂, and 2 spp. ♂ ♀.
- Plumose setae throughout, but lacking area of short dense white setae on dorsum of petiole; propodeum short, length in lateral view  $\leq 0.5x$  height; first metasomal segment petiolate with second ..... *Sphaerophthalma (Photopsioides)*  
**Fauna:** 3 spp. ♂, and 1 sp. ♂ ♀.
20. (14) Pygidial area well-defined; petiole not disciform (Fig. 34) ..... *Dasymutilla*  
**Key:** Mickel 1928, 1936a.  
**Fauna:** 33 spp. ♂, 48 spp. ♀, and 44 spp. ♂ ♀.
- Pygidial area obsolete, not defined laterally; petiole distinctly disciform (Figs. 35, 36) ..... 21
21. (20) Anterior and propodeal spiracles tuberculate (Fig. 35) ..... *Lomachaeta*  
**Key:** Mickel 1940. **Fauna:** 4 spp. ♂, 1 sp. ♀, and 2 spp. ♂ ♀.
- Anterior and propodeal spiracles not tuberculate ..... *Smicromutilla*  
**Fauna:** 1 sp. ♂ ♀.
22. (1) Hind coxa with dorsal lamella (Fig. 14); felt line on lateral margin of tergite II absent; forewing with M and CuI extending to apical margin (Fig. 37); jugal lobe present (subfamily Myrmosinae) ..... 23
- Hind coxa without dorsal lamella (Fig. 12); felt line on lateral margin of tergite II present; forewing with M and CuI ending far from apical margin (Figs. 38, 39); jugal lobe absent ..... 25
23. (22) Sternites I and II with median process near base; clypeus with median longitudinal carina or keel at base ..... *Myrmosa (Myrmosa)*  
**Key:** Krombein 1939. **Fauna:** 2 spp. ♀, and 2 spp. ♂ ♀.
- Sternite II simple, lacking median process near base ..... 24
24. (23) Sternite I with hook-like median process near base; clypeus with median longitudinal carina at base ..... *Myrmosa (Myrmosina)*  
**Key:** Krombein 1939.  
**Fauna:** 2 spp. ♂.
- Sternite I simple; clypeus convex, without carina ..... *Myrmosula*  
**Key:** Krombein 1939. **Fauna:** 1 sp. ♂, 6 spp. ♀, and 1 sp. ♂ ♀.

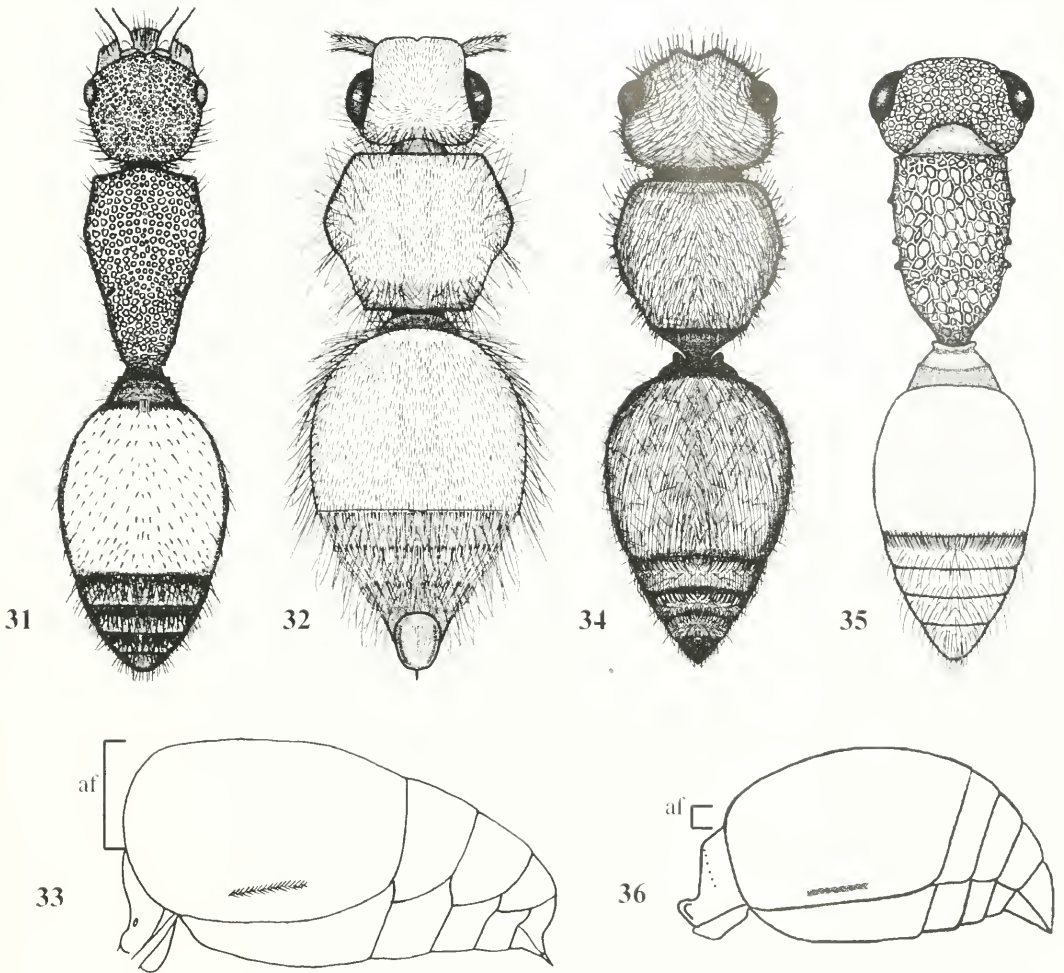

Figs. 31–36. 31, *Sphaerophthalma* (*Sphaerophthalma*) *pennsylvanica*, dorsal view. 32, *Sphaerophthalma* (*Photopsis*) sp., dorsal view. 33, *Stethophotopsis maculata*, metasoma, lateral view (af, anterior face). 34, *Dasytmulla* sp., dorsal view. 35–36, *Lomachaeta variegata*. 35, Dorsal view; 36, Metasoma, lateral view (af, anterior face).

- 25. (22) Compound eye approximately hemispherical, smooth and shiny (Figs. 44, 46, 50); pterostigma sclerotized (Figs. 38, 49, 51, 52) (subfamily Sphaerophthalminae, tribe Sphaerophthalmini) ..... 26
- Compound eye with inner margin deeply and sharply emarginate (Figs. 53, 54); pterostigma membranous or absent (Fig. 39) (subfamily Mutillinae) ..... 48
- 26. (25) Metasomal segment I completely sessile with second (Fig. 20) ..... 27
- Metasoma petiolate or at most subsessile, with definite constriction between first two segments (Fig. 21) (subtribe Sphaerophthalmina, in part) ..... 29
- 27. (26) Felt line present on lateral margin of tergite II and sternite II; eyes ovate; wings absent (subtribe Sphaerophthalmina, in part) ..... *Morsyma*  
**Fauna:** 1 sp. ♂.
- Felt line present on lateral margin of tergite II only; eyes round; wings present (subtribe Pseudomethocina) ..... 28
- 28. (27) Hypostomal tooth well developed; head extremely large, about twice width of me-

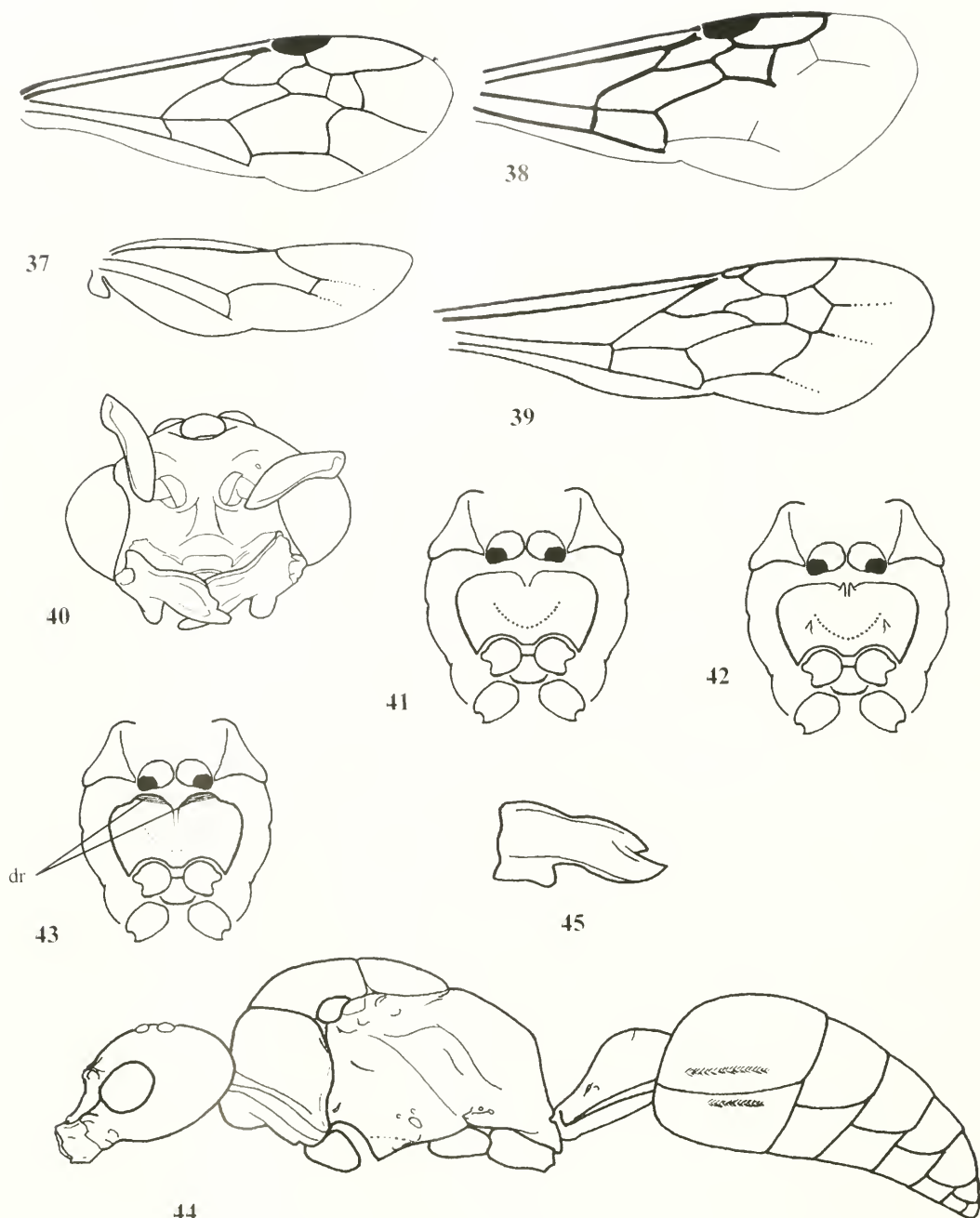

Figs. 37–45. 37, Myrmosinae, anterior and posterior wing. 38, Sphaerophthalminae, anterior wing. 39, Mutillinae, anterior wing. 40, *Acrophotopsis curygnathus*, head, frontal view. 41, *Sphaerophthalma (Photopsis) imperialis*, sternum. 42, *Odontophotopsis* sp., sternum. 43–45, *Photomorphus* sp. 43, Sternum (dr, denticulate ridge); 44, Habitus with legs removed; 45, Mandible.

- sosoma; posterolateral angles of head strongly carinate, dentiform; wings brachypterous ..... *Myrmilloides*  
**Fauna:** 1 sp. ♂ ♀.
- Hypostomal tooth not developed; head less than twice width of mesosoma; posterolateral angles of head not strongly carinate or dentiform; wings macropterous ..... *Pseudomethoca*  
**Key:** Mickel 1935. **Fauna:** 7 spp. ♂, 18 spp. ♀, and 17 spp. ♂ ♀.
29. (26) Felt line present on lateral margin of tergite II and sternite II ..... 30
- Felt line present on lateral margin of tergite II only ..... 39
30. (29) Ventral mandibular tooth lacking; mesoscutal notauli absent; flagellomere I short, transverse, similar in form to pedicel ..... *Protophotopsis*  
**Key:** Cambra and Quintero 1997. **Fauna:** 1 sp. ♂ ♀.
- Ventral mandibular tooth present; mesoscutal notauli present; flagellomere I longer than wide, not like pedicel ..... 31
31. (30) Hypopygium broadly emarginate distally, transverse, lateral margins strongly dentiform; parameres dorsal-ventrally flattened; mandible broadly dilated, with very large subtending tooth (Fig. 40) [*Dilophotopsis stenognatha* may key here due to the evaluation of the sternal felt line as being present. In most specimens, however, it is not present. It differs from *Acrophotopsis* in having the processes on the mesosternum (see diagnoses)] ..... *Acrophotopsis*  
**Key:** Schuster 1958. **Fauna:** 2 spp. ♂.
- Hypopygium normal, rounded, lateral margins not carinate or dentiform; mandible only slightly emarginate, ventral tooth small (Fig. 45) ..... 32
32. (31) Mesosternum variously modified with distinct teeth, tubercles, spines (Fig. 42), or denticulate ridges (Fig. 43, dr) (teeth indistinct in some *Odontophotopsis*) ..... 33
- Mesosternum simple, unmodified, without teeth, tubercles, spines, or ridges (Fig. 41) (*Sphaerophthalma*) ..... 37
33. (32) Cuspid dilated and subequal in length to parameres; mesosternum with pair of transverse dentate ridges just anterior to mesocoxae, closely spaced, appearing to cup anterior margin of mesocoxae ..... *Stethophotopsis*  
**Fauna:** 1 sp. ♀, and 1 sp. ♂ ♀.
- Cuspid not dilated and much shorter than parameres; mesosternum with pair of longitudinal to transverse dentate ridges anterior to mesocoxae, closer to procoxae, not appearing to cup anterior margin of mesocoxae (Figs. 43, 44) ..... 34
34. (33) Mesosternum with denticulate, or transversely dentiform, ridge-like processes (Figs. 43, 44), never with isolated single processes on each side of mesosternum; plumose hairs vestigial or absent ..... (*Photomorphus*) 35
- Mesosternum with pair of conspicuous to minute teeth or tubercles, far before mesocoxae and/or a small process anterior to mesocoxae; plumose setae present ..... (*Odontophotopsis*) 36
35. (34) Mesocoxae approximate; mandible tridentate apically; mentum never produced into a distinct process ..... *Photomorphus (Photomorphina)*  
**Key:** Schuster 1958. **Fauna:** 26 spp. ♂, 1 sp. ♀, and 1 sp. ♂ ♀.
- Mesocoxae separated; mandible bidentate apically (Fig. 45); mentum distinctly produced as an anterior tubercle or posterior lingulate process ..... *Photomorphus (Photomorphus)*  
**Key:** Schuster 1958. **Fauna:** 4 spp. ♂, 1 sp. ♀, and 2 spp. ♂ ♀.
36. (34) Mesosternum armed only with pair of tumid, gibbous, nitid, impunctate longitudinal elevations directly anterior to mesocoxae ..... *Odontophotopsis (Periphotopsis)*  
**Fauna:** 1 sp. ♂.
- Mesosternum armed with conspicuous to minute teeth or tubercles, at least anterior

- pair (if more than one) far before mesocoxae ..... *Odontophotopsis (Odontophotopsis)* (in part)  
**Key:** Schuster 1958. **Fauna:** 44 spp. ♂.
- 37. (32) Notauli incomplete, limited to distal half of mesoscutum; sternite II with elongate, well-developed felt line; plumose setae present or absent; metacoxae unarmed ..... *Sphaerophthalma (Micromutilla)*  
**Key:** Schuster 1958. **Fauna:** 17 spp. ♂.
  - Notauli complete; felt line of sternite II short, small tufts; plumose setae always distinct; metacoxae often armed ..... 38
- 38. (37) Notauli deep, lines distinctly deeper than wide; felt line of sternite II distinct; mandible acuminate distally, bidentate or bidentate with a small, median third tooth ..... *Sphaerophthalma (Physetapsis)*  
**Key:** Schuster 1958. **Fauna:** 4 spp. ♂.
  - Notauli not deep on mesoscutum, lines wider than deep; felt line of sternite II not distinct; mandible distinctly tridentate ..... *Sphaerophthalma (Photopsis)* (in part)  
**Key:** Schuster 1958. **Fauna:** 41 spp. ♂, 21 spp. ♀, and 2 spp. ♂ ♀.
- 39. (29) Mesotibia with single spur; mesotibia flattened, arcuate; mesosternum armed with large, conical process before each coxa (Figs. 46, 47); plumose setae vestigial or absent ..... *Acanthophotopsis*  
**Key:** Schuster 1958. **Fauna:** 5 spp. ♂.
  - Mesotibia with two spurs; mesotibia cylindrical, not flattened and arcuate; mesosternum armed with small tubercles, conical processes, or unarmed; plumose setae present or absent ..... 40
- 40. (39) Mesosternum with pair of prominent, peg-like or conical, widely separated, anteriorly situated processes or with pair of spur-like, closely spaced, anteriorly situated tubercles; may also have pair of spine-like tubercles, widely separated, immediately before mesocoxae (Figs. 42, 48) ..... 41
  - Mesosternum unmodified (Fig. 41) ..... 42
- 41. (40) Hypopygium broadly emarginate distally, transverse; parameres dorsoventrally flattened; mesosternum with pair of prominent, peg-like or conical, widely separated, anteriorly-situated processes (Fig. 48) ..... *Dilophotopsis*  
**Key:** Schuster 1958. **Fauna:** 1 sp. ♂, and 1 sp. ♂ ♀.
  - Hypopygium not broadly emarginate distally; parameres not dorsoventrally flattened; mesosternum with pair of spine-like tubercles, closely spaced, anteriorly-situated on midline; may also have pair of spine-like tubercles, widely separated, immediately before mesocoxae (Fig. 42) ... *Odontophotopsis (Odontophotopsis)* (in part)  
**Key:** Schuster 1958. **Fauna:** 44 spp. ♂.
- 42. (40) Mandible tridentate apically, broadly emarginate ventrally with small, distinct tooth ..... 43
  - Mandible bidentate or tridentate apically, but not emarginate or toothed ventrally ..... 46
- 43. (42) Notauli absent; tergites II—V with row of lanceolate bristles at distal margin; pterostigma of forewing vestigial, inconspicuous (Fig. 49) ..... *Lomachaeta*  
**Key:** Mickel 1940. **Fauna:** 4 spp. ♂, 1 sp. ♀, and 2 spp. ♂ ♀.
  - Notauli present, complete; tergites II—V without row of lanceolate bristles at distal margin; pterostigma of forewing conspicuous ..... 44
- 44. (43) Marginal cell distinctly elongate, much longer than stigma; pygidium and hypopygium distinctly elongate; ventral tooth of mandible often large; cuspis never spatulate or dilated distally, never bearing plumose setae; coxa often armed ..... *Sphaerophthalma (Photopsis)* (in part)  
**Key:** Schuster 1958. **Fauna:** 41 spp. ♂, 21 spp. ♀, and 2 spp. ♂ ♀.
  - Marginal cell length equal to or slightly longer than stigma; pygidium and hypo-

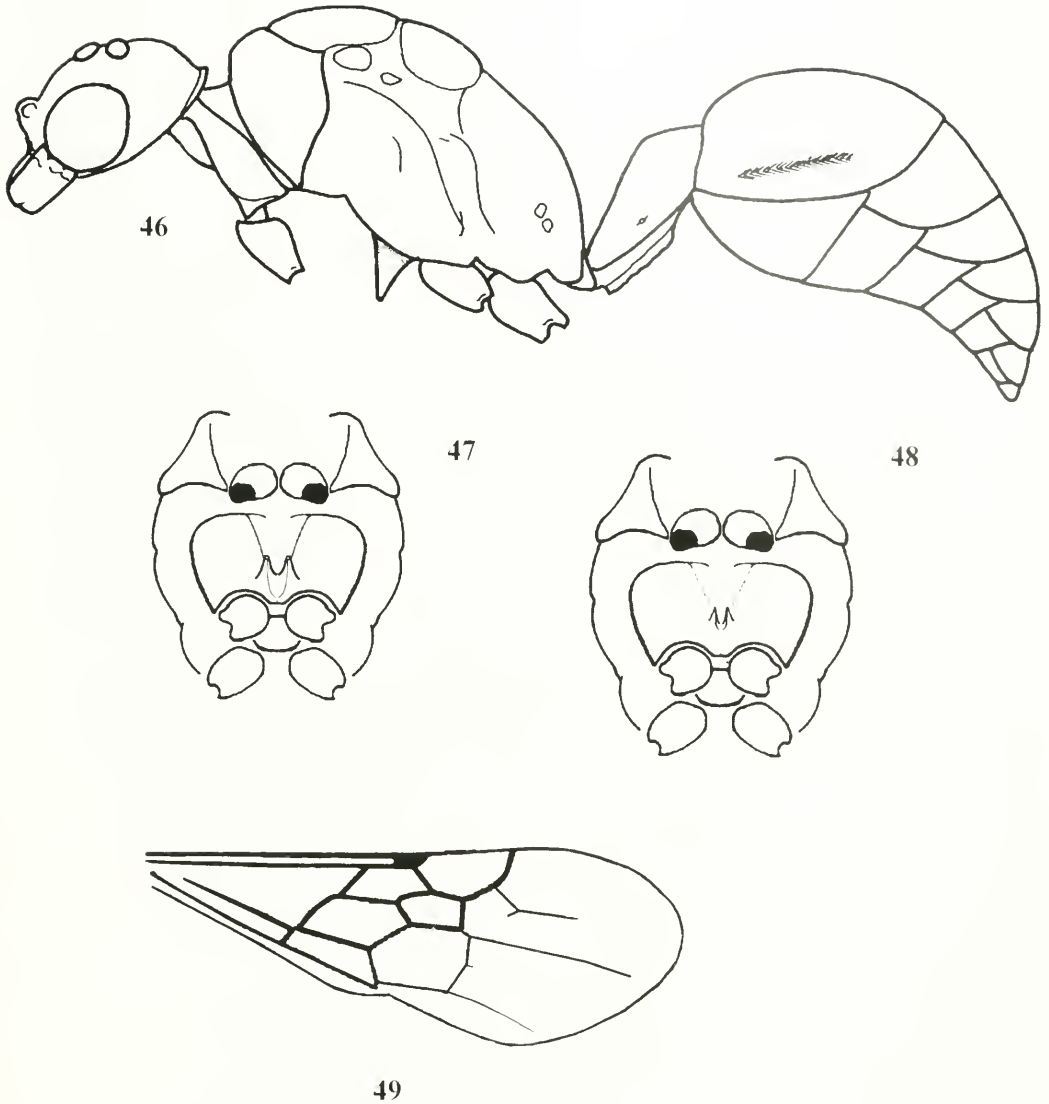

Figs. 46–49. *Acanthophotopsis dorophora*. 46, Habitus with legs removed; 47, Sternum. 48, *Dilophotopsis concolor*, sternum. 49, *Lomachaeta formosula*, anterior wing.

- pygium short, transverse; ventral tooth of mandible usually small; cuspis spatulate, dilated distally, bearing plumose setae; coxa never armed ..... 45
45. (44) Eyes and ocelli large, bulging, compound eye touching base of mandible, distance from compound eye to posterolateral angle of head less than greatest diameter of eye; nocturnal forms, *Photopsis*-like in appearance; setae white or golden throughout ..... *Sphaerophthalma* (*Photopsioides*)  
**Key:** Schuster 1958. **Fauna:** 3 spp. ♂, and 1 sp. ♂ ♀.
- Eyes and ocelli small, not protuberant, compound eye distinctly separated from mandible, distance from compound eye to posterolateral angle of head distinctly greater than greatest diameter of eye; diurnal forms, entirely unlike *Photopsis* in appearance; setae black and golden throughout ..... *Sphaerophthalma* (*Sphaerophthalma*)  
**Key:** Schuster 1958. **Fauna:** 1 sp. ♂, and 2 spp. ♂ ♀.

- 46. (42) Tergites II—V with row of lanceolate bristles at distal margin; subplumose setae present ..... *Lomachaeta*  
**Key:** Mickel 1940. **Fauna:** 4 spp. ♂, 1 sp. ♀, and 2 spp. ♂ ♀.
- Tergites II—V without row of lanceolate bristles at distal margin; subplumose setae absent ..... 47
- 47. (46) Wing venation greatly reduced; pterostigma of forewing vestigial, inconspicuous (Fig. 51) ..... *Smicronutilla*  
**Fauna:** 1 sp. ♂ ♀.
- Wing venation normal, not greatly reduced; pterostigma of forewing conspicuous (Fig. 52) ..... *Dasynutilla*  
**Key:** Mickel 1928, 1936a. **Fauna:** 33 spp. ♂, 48 spp. ♀, and 44 spp. ♂ ♀.
- 48. (25) Metasomal segment I sessile with second (Fig. 53); humeral angles rounded . . . *Timulla*  
**Key:** Mickel 1937. **Fauna:** 13 spp. ♂, 6 spp. ♀, and 11 spp. ♂ ♀.
- Metasomal segment I slender, short, parallel-sided, not sessile (Fig. 54); humeral angles angulate, sharply produced; small; densely punctate (*Ephuta*) ..... 49
- 49. (48) Mandible falcate, tip not strongly deflected, with contours smooth ventrally, not emarginate or dentate; dorsal margin of mandible not produced as prominent, lamellate tooth; clypeus convex, with two usually divergent carinae running down from common origin below and between antennal tubercles; lateral face of pronotum not armed with tooth below ..... *Ephuta (Ephuta)*  
**Key:** Schuster 1951, 1956. **Fauna:** 13 spp. ♂, 9 spp. ♀, and 6 spp. ♂ ♀.
- Mandible contorted, distal half sharply deflected, with ventral margin interrupted and with small, subtending tooth; dorsal margin of mandible expanded before middle into prominent lamellate expansion; clypeus strongly depressed, forming basin with closed mandibles, without carinae, but with sharp, finger-like process at junction with frons; lateral face of pronotum armed with small tooth near base of coxa . . . .  
..... *Ephuta (Xenochile)*  
**Fauna:** 1 sp. ♂.

GENERIC DIAGNOSES

*Acrophotopsis* Schuster 1958:61

*Acanthophotopsis* Schuster 1958:88

Type-species: *Acanthophotopsis falciformis* Schuster

*Male.*—Eyes entire, small, weakly protruding; plumose setae absent; mandible with broad ventral excision, not toothed; notauli complete; sternum armed with large conical processes directly anterior to mesocoxae (Figs. 46, 47); mesotibia with one calcar; mesotibia more or less flattened and arcuate, stout at base, flattened; cuspis elongate, reaching nearly to apex of parameres, apex slightly dilated with short, dense, simple setae.

*Female.*—Unknown.

*Distribution.*—Southwestern U.S., Mexico.

*Hosts.*—Unknown.

Type-species: *Acrophotopsis eurygnathus* Schuster

*Male.*—Eyes entire, moderately protruding; plumose setae present; mandible tridentate, extremely deeply emarginate ventrally, with very large subtending tooth (Fig. 40); mentum carinate-tuberculate longitudinally; notauli absent or obscure on anterior third of mesoscutum; mesosternum unarmed; sternal felt line distinct; hypopygium broadly emarginate distally, lateral margins strongly carinate, disk strongly depressed; parameres strongly flattened, blade-like, overlapping in normal retracted position; cuspis uniformly wide.

*Female.*—Unknown.

*Distribution.*—Southwestern U.S..

*Hosts.*—Unknown.

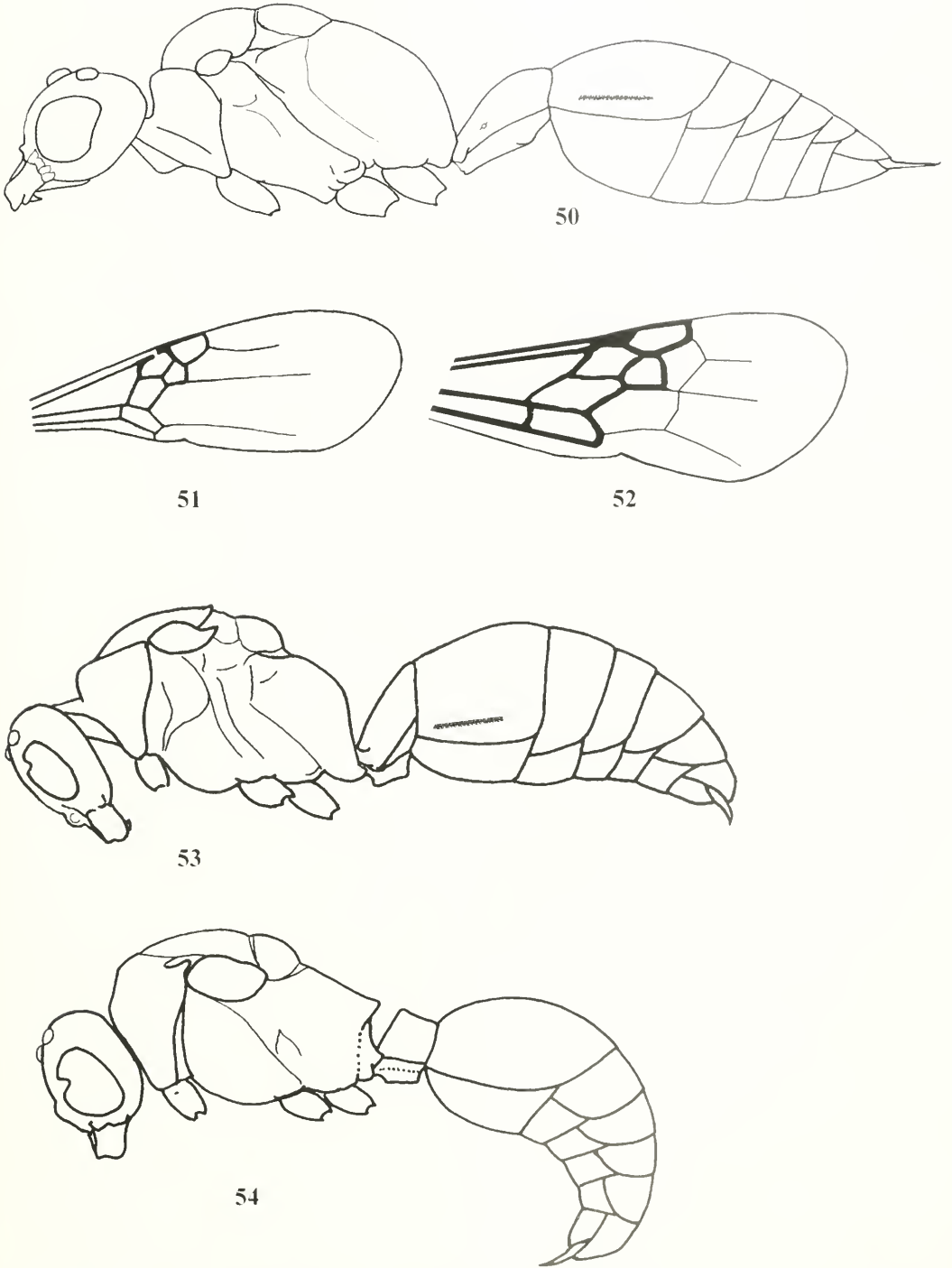

Figs. 50–54. 50, *Sphaerophthalma (Photopsis)* sp., habitus with legs removed. 51, *Smicromutilla powelli*, anterior wing. 52, *Dasymutilla chattahoochei*, anterior wing. 53, *Timulla dubitata*, habitus with legs removed. 54, *Epluta stenognatha*, habitus with legs removed.

*Caenotilla* Pitts and Manley 2002

Type-species: *Caenotilla choreocarina* Pitts and Manley

*Male*.—Unknown.

*Female*.—See generic description (p. 73, this paper).

*Distribution*.—California.

*Hosts*.—Unknown, see generic description (p. 73, this paper).

*Dasymutilla* Ashmead 1899:57

Type-species: *Mutilla* (*Sphaerophthalma*) *Gorgon* Blake

*Male*.—Compound eyes approximately hemispherical, smooth and shiny; pterostigma completely sclerotized (Fig. 52); metasoma petiolate, with definite constriction between first two segments (Fig. 21); felt line present on tergite II only; mesotibia with two spurs; mesosternum simple, completely unmodified (Fig. 41); mandible not emarginate or toothed ventrally; wing venation normal, not reduced; axilla prominent; notauli absent.

*Female*.—Compound eyes approximately hemispherical; metasoma petiolate, with definite constriction between first two segments (Fig. 21); felt line present on tergite II only; plumose setae lacking; pygidial area distinct, well-defined (Fig. 34).

*Distribution*.—Throughout U.S., Mexico, Central America, barely into South America, southern Canada.

*Hosts*.—*Anthophora* Fabricius, *Bombix* Fabricius, *Bombus* Latreille, *Cerceris* Latreille, *Diadasia* Patton, *Dialictus* Robertson, *Dianthidium* Cockerell, *Megachile* Latreille, *Microbombix* Patton, *Myzinum* Latreille, *Nomia* Latreille, *Paranthidium* Cockerell and Cockerell, *Philanthus* Fabricius, *Polistes* Latreille, *Ptilothrix* Smith, *Sphex*.

*Dilophotopsis* Schuster 1958:71

Type-species: *Mutilla concolor* Cresson

*Male*.—Eyes entire, large and protruding; plumose setae present; mandible tridentate and extremely, deeply emarginate ventrally, with very large subtending

tooth; mentum flat; notauli complete or subcomplete; mesosternum armed with pair of peg-like processes situated anteriorly (Fig. 48); sternal felt line vestigial or absent; hypopygium broadly emarginate distally, lateral margins strongly carinate, disk strongly depressed; parameres moderately flattened, not blade-like; cuspis suddenly narrowed and angulate distally.

*Female*.—Head distinctly wider than mesosoma; mandible edentate at tip, with small tooth within third of distance from base, emarginate beneath, with large subtending ventral tooth; eyes subovate, entire; antennal scrobes not carinate; genal carina absent; mesosoma pyriform, widest anteriorly, gradually narrowed posteriorly; anterior and propodeal spiracles not tuberculate; metasomal segment I subsessile with second (Fig. 11); pygidial area granulate, defined laterally by carinae (Fig. 34); plumose setae present on posterior margin of head, anterior margin of mesosoma, and apical margins of all terga.

*Distribution*.—Western U.S. and Canada, Mexico.

*Hosts*.—Unknown.

*Ephuta* (*Ephuta*) Say 1836:297

Type-species: *Mutilla* (*Ephuta*) *scrupea* Say

*Male*.—Compound eyes emarginate (Fig. 53, 54); metasomal segment I slender, short, parallel-sided, not sessile with second (Fig. 54); humeral angle sharply produced; small; densely punctate; felt line present on tergite II; axilla absent; notauli absent; dorsal margin of mandible not produced as prominent, lamellate tooth; clypeus convex, with two usually divergent carinae running down from common origin below and between antennal tubercles; lateral face of pronotum not armed with tooth below.

*Female*.—Eyes ovate; metasomal segment I short, transverse, parallel-sided (Fig. 30); a band of dense, silvery, sericeous vestiture at apex of petiole and me-

tasomal segment II; small; densely punctate; felt lines lacking.

*Distribution*.—Throughout much of western hemisphere.

*Hosts*.—*Anoplius* Dufour, *Dipogon* Fox.

*Ephuta (Xenochile)* Schuster 1956:8

Type-species: *Ephuta (Xenochile) kroubeiu* Schuster

*Male*.—Compound eyes emarginate (Fig. 53, 54); metasomal segment I slender, short, parallel-sided, not sessile with second (Fig. 54); humeral angle sharply produced; small; densely punctate; felt line present on tergite II; axilla absent; notauli absent; dorsal margin of mandible expanded before middle into prominent lamellate expansion; clypeus strongly depressed, forming basin with closed mandibles, without carinae, but with sharp, finger-like process at junction with frons; lateral face of pronotum armed with small tooth near base of coxa.

*Female*.—Unknown.

*Distribution*.—Arizona.

*Hosts*.—Unknown.

*Leiomyrmosa* Wasbauer 1973:325

Type-species: *Leiomyrmosa spilota* Wasbauer

*Male*.—Unknown.

*Female*.—Hind coxa with dorsal lamella (Fig. 14); felt lines lacking (Fig. 16); pronotum and mesonotum not fused (Fig. 13); sternite I simple, lacking a median process; ocelli absent; clypeus simple, lacking median spine or tooth; mandible with large apical tooth and two very small teeth on inner margin; ventral mandibular lamella absent; prothoracic tarsus with rake consisting of long, spatulate spines at outer apex of each segment (Fig. 18).

*Distribution*.—California.

*Hosts*.—Unknown.

*Lomachaeta* Mickel 1936b:289

Type-species: *Lomachaeta hicksi* Mickel

*Male*.—Head slightly wider than mesosoma; mandible emarginate beneath, usu-

ally with subtending tooth; tip of mandible edentate, with two small teeth within; eyes subovate, margins entire; axilla prominent; metasomal segment I petiolate with second (Fig. 21); felt line on tergite II only; tergites II–VI with a row of stout bristles at distal margin; stigma reduced, inconspicuous; setae simple or serrate.

*Female*.—Head distinctly wider than mesosoma; integument of head and mesosoma reticulate; mandible not emarginate or toothed beneath, with single tooth within; eyes subovate, entire; mesosoma pyriform, widest anteriorly, gradually narrowed posteriorly; anterior and propodeal spiracles tuberculate (Fig. 35); metasomal segment I much smaller than second, petiolate (Fig. 35, 36); felt line on tergite II only; pygidial area nitid, not defined laterally; setae simple.

*Distribution*.—Much of U.S. and Mexico.

*Hosts*.—*Solierella* Spinola.

*Morsyma* Fox 1899:287

Type-species: *Morsyma Ashmeadii* Fox

*Male*.—Head slightly wider than mesosoma; eyes entire; sculpture coarsely punctate; plumose setae present on apical fringe of tergum II; mandible emarginate ventrally, with subtending tooth or angulation; antennal scrobes lacking a tubercle; clypeus often tuberculate at base; notauli absent; mesosternum unarmed; metasomal segment I sessile with second (Fig. 20); sternal felt line well developed; parameres and cuspis slender; wingless.

*Female*.—Unknown.

*Distribution*.—California.

*Hosts*.—Unknown.

*Myrmilloides* André 1903:26

Type-species: *Mutilla (Sphacrophthalma) graudiceps* Blake

*Male*.—Compound eyes approximately hemispherical, smooth and shiny; pterostigma completely sclerotized (Fig. 38, 49, 51, 52); metasomal segment I completely sessile with second (Fig. 20); felt line present on tergite II only; head extremely

large, quadrate, about twice width of mesosoma; hypostomal tooth well developed; posterolateral angles of head strongly carinate, dentiform; axilla absent; notauli absent.

*Female*.—Compound eyes round; head extremely large, quadrate (Fig. 22, 24, 26), about twice width of mesosoma; hypostomal tooth well developed; posterolateral angles of head strongly carinate, dentiform (Fig. 25); antennal tubercles dentate, prominently raised; metasomal segment I completely sessile with second (Fig. 20); pygidium without lateral carinae; felt line on tergite II only.

*Distribution*.—Much of southern U.S.

*Hosts*.—*Augochlorella* Sandhouse, *Dialictus* Robertson.

#### *Myrmosa (Myrmosa)* Latreille 1796:118

Type-species: *Myrmosa atra* Panzer

*Male*.—Hind coxa with dorsal lamella (Fig. 14); felt lines lacking; forewing with M and Cu1 extending to apical margin (Fig. 37); jugal lobe present; sternites I and II with median process near base; clypeus with median longitudinal carina or keel at base.

*Female*.—Hind coxa with dorsal lamella (Fig. 14); felt lines lacking; pronotum and mesonotum not fused (Fig. 13); sternite I with median process near base (Fig. 16); ocelli usually present; clypeus with median spine or tooth.

*Distribution*.—Throughout much of U.S.

*Hosts*.—*Dialictus* Robertson, *Lindenius* Lepeletier and Brulle, *Tiphia* Fabricius.

#### *Myrmosa (Myrmosina)* Krombein 1939: 452

Type-species: *Myrmosa (Myrmosina) texana* Krombein

*Male*.—Hind coxa with dorsal lamella (Fig. 14); felt lines lacking; forewing with M and Cu1 extending to apical margin (Fig. 37); jugal lobe present; sternite I with hook-like median process near base; sternite II simple; clypeus with median longitudinal carina at base.

*Female*.—Unknown.

*Distribution*.—Throughout much of U.S.

*Hosts*.—Unknown.

#### *Myrmosula* Bradley 1917:249

Type-species: *Myrmosa parvula* Fox

*Male*.—Hind coxa with dorsal lamella (Fig. 14); felt lines lacking; forewing with M and Cu1 extending to apical margin (Fig. 37); jugal lobe present; sternites I and II simple, lacking median processes; clypeus convex, without a carina.

*Female*.—Hind coxa with dorsal lamella (Fig. 14); felt lines lacking; pronotum and mesonotum not fused (Fig. 13); sternite I simple, lacking median process; ocelli absent; clypeus simple, lacking median spine or tooth; mandible with two apical teeth; ventral mandibular lamella present; prothoracic tarsus without rake (Fig. 17).

*Distribution*.—Throughout much of U.S., into Canada.

*Hosts*.—*Augochlorella* Sandhouse, *Dialictus* Robertson, *Nomadopsis* Ashmead.

#### *Odontophotopsis (Odontophotopsis)* Viereck 1902:738

Type-species: *Odontophotopsis exogyrus* Viereck

*Male*.—Eyes entire, large and protruding; sculpture usually weak and distant; plumose setae present; mandible emarginate ventrally and with subtending tooth or angulation; clypeus sometimes tuberculate at base; notauli subcomplete or obscure on anterior third of mesoscutum; mesosternum armed with peg-like processes situated anteriorly (Fig. 42), rarely with 2–5 distinct teeth on each side (one species with crescent-shaped process on each side), at least anterior pair (if more than one) far before mesocoxae; metasomal segment I petiolate or subsessile with second; sternal felt line absent or very short; parameres and cuspis slender.

*Female*.—Unknown.

*Distribution*.—Throughout much of southwestern and western U.S., into Canada.

*Hosts.*—*Anthophora* Fabricius.

***Odontophotopsis (Periphotopsis)***

Schuster 1958:60

Type-species: *Odontophotopsis (Periphotopsis) mamatus* Schuster

*Male.*—Eyes entire, large and protruding; sculpture usually weak and distant; plumose setae present; mandible emarginate ventrally and with subtending tooth or angulation; clypeus sometimes tuberculate at base; notauli subcomplete or obscure on anterior third of mesoscutum; mesosternum armed only with pair of tumid, gibbous, nitid, impunctate longitudinal elevations directly anterior to mesocoxae (Fig. 42); metasomal segment I petiolate or subsessile with second (Fig. 21); sternal felt line absent or very short; parameres and cuspis slender.

*Female.*—Unknown.

*Distribution.*—Southwestern U.S.

*Hosts.*—Unknown.

***Photomorphus (Photomorphus) Viereck***

1903:249

Type-species: *Photomorphus Johnsoni* Viereck

*Male.*—Eyes entire, small and weakly protruding; sculpture coarsely and often closely punctured; plumose setae absent or vestigial; mandible emarginate ventrally and with subtending tooth or angulation (Fig. 45); clypeus often tuberculate at base; notauli subcomplete or obscure on anterior third of mesoscutum; mesosternum armed with denticulate longitudinal or transverse carinae (Figs. 43, 44); metasomal segment I petiolate with second (Fig. 21); sternal felt line well developed; parameres and cuspis slender; mesocoxae separated; mandible bidentate apically; mentum distinctly produced as an anterior tubercle or posterior lingulate process.

*Female.*—Head as wide as mesosoma; mandible edentate at tip, with small tooth within a third of distance from base, emarginate beneath and with large subtending ventral tooth or not; eyes ovate; mesosoma

rectangular (Fig. 29); anterior and propodeal spiracles slightly tuberculate; metasomal segment I sessile with second (Fig. 20), width at posterior margin slightly less than half greatest width of second; felt line on tergite II only; pygidium smooth and shiny, with complete parallel carinae on disk; simple setae, although plumose setae may be present on apical fringes of terga.

*Distribution.*—Throughout much of U.S.

*Hosts.*—Unknown.

***Photomorphus (Photomorphina) Schuster***

1952:53

Type-species: *Photomorphus (Photomorphina) aurifera* Schuster

*Male.*—Eyes entire, small and weakly protruding; sculpture coarsely and often closely punctured; plumose setae absent or vestigial; mandible emarginate ventrally and with subtending tooth or angulation; clypeus often tuberculate at base; notauli subcomplete or obscure on anterior third of mesoscutum; mesosternum armed with denticulate longitudinal or transverse carinae (Fig. 43, 44); metasomal segment I petiolate with second (Fig. 21); sternal felt line well developed; parameres and cuspis slender; mesocoxae approximate; mandible tridentate apically; mentum never produced into a distinct process.

*Female.*—Head as wide as mesosoma; mandible edentate at tip, with small tooth within a third of distance from base, emarginate beneath and with large subtending ventral tooth or not; eyes ovate; mesosoma rectangular (Fig. 29); anterior and propodeal spiracles slightly tuberculate; metasomal segment I sessile with second (Fig. 20), width at posterior margin slightly less than half greatest width of second; felt line on tergite II only; pygidium dull, with parallel carinae only on basal two-thirds or less; simple setae, although plumose setae may be present on apical fringes of terga.

*Distribution.*—Throughout much of U.S.

*Hosts.*—Unknown.

*Protophopsis* Schuster 1946:693

Type-species: *Protophopsis scudleri* Schuster

*Male*.—Eyes entire; sculpture coarsely and often closely punctured; plumose setae absent; mandible not emarginate ventrally, without subtending tooth or angulation; anterior margin of mesonotum emarginate medially; notauli absent; mesosternum unarmed (Fig. 41); sternal felt line well developed; metasomal tergites with pale curled bristles on apical margins; parameres and cuspis slender.

*Female*.—Head as wide as mesosoma; integument of head and mesosoma punctate; mandible bidentate distally, not emarginate or toothed beneath; eyes subovate and entire; genal carina absent; mesosoma subrectangular; anterior and propodeal spiracles slightly tuberculate; metasomal segment I subsessile with second (Fig. 21); felt line present on tergite II and sternite II (Fig. 19), sometimes felt line of sternite II inconspicuous; pygidial area nitid, not defined laterally; simple and microserate setae present.

*Distribution*.—Kansas, Texas, California, Colorado.

*Hosts*.—Unknown.

*Pseudomethoca* Ashmead 1896:181

Type-species: *Photopsis Cressoni* Fox

*Male*.—Compound eyes approximately hemispherical, smooth and shiny; pterostigma completely sclerotized; metasomal segment I completely sessile with second (Fig. 20); felt line present on tergite II only; head large, quadrate, but much less than twice width of mesosoma; posterolateral angles of head usually not strongly carinate or dentiform; plumose setae lacking; axilla prominent; notauli absent.

*Female*.—Compound eyes round; head large, quadrate (Figs. 22, 24, 26), but less than twice width of mesosoma; posterolateral angles of head usually not strongly carinate or dentiform; metasomal segment I completely sessile with second (Fig. 20);

felt line on tergite II only; plumose setae lacking.

*Distribution*.—Throughout much of western hemisphere.

*Hosts*.—*Angochlorella* Sandhouse, *Dialictus* Robertson, *Etylaeus* Robertson, *Nomia* Latreille.

*Smicromutilla* Mickel 1964:108

Type-species: *Smicromutilla powelli* Mickel

*Male*.—Head slightly wider than mesosoma; mandible not emarginate beneath; tip of mandible edentate, with two small teeth within; eyes subovate, margins entire; ocelli small, ocellular distance three times width of a lateral ocellus; axilla prominent; metasomal segment I subsessile with second (Fig. 21); felt line on tergite II only; terga without a row of bristles at margin; stigma vestigial, inconspicuous (Fig. 51).

*Female*.—Head distinctly wider than mesosoma; integument of head and mesosoma reticulate; mandible with single tooth within, not emarginate or toothed beneath; eyes subovate and entire; mesosoma pyriform, widest anteriorly, gradually narrowed posteriorly; anterior and propodeal spiracles not tuberculate; metasomal segment I subsessile with second (Fig. 21); felt line on tergite II only; pygidial area nitid, not defined laterally; simple setae only.

*Distribution*.—California.

*Hosts*.—*Diodontus* Curtis.

*Sphaerophthalma* (*Sphaerophthalma*) Blake 1871:232

Type-species: *Mutilla* (*Sphaerophthalma*) *scaeva* Blake

*Male*.—Head slightly wider than mesosoma; marginal cell length equal to or slightly longer than stigma; ventral tooth of mandible usually small; eyes subovate, margins entire; eyes and ocelli small, compound eye separated from base of mandible, distance between posterior margin of compound eye and posterolateral angle

of head conspicuously greater than greatest diameter of eye; sternum unmodified (Fig. 41); metasomal segment I subsessile with second (Fig. 21); felt line absent on sternite II; with conspicuous plumose setae; cuspis spatulate, dilated distally, bearing plumose setae; setae black and golden throughout.

*Female*.—Head as wide as mesosoma; integument of head and mesosoma punctate; mandible with a single tooth within, emarginate beneath, with prominent sub-basal tooth; eyes subovate and entire; genal carina absent; mesosoma pyriform, widest anteriorly, gradually narrowed posteriorly; anterior and propodeal spiracles not tuberculate; metasomal segment I petiolate with second (Fig. 21); felt line on tergite II only; plumose setae limited to area of short dense white setae on dorsum of petiole (Fig. 31), and apical fringe of tergite II; antennal scrobe carinate dorsally; flagellomere II  $2\times$  length of first; propodeum elongate, length in lateral view equal to  $0.75\times$  height; pygidial area undefined laterally.

*Distribution*.—Throughout much of U.S.

*Hosts*.—*Auplopus* Spinola, *Chalybion* Dahlbom, *Sceliphron* Klug, *Trypargilum* Richards.

### *Sphaerophthalma (Micromutilla)*

Ashmead 1899:39

Type-species: *Photopsis nanus* Ashmead

*Male*.—Head slightly wider than mesosoma; eyes subovate, margins entire; pterostigma sclerotized (Figs. 38, 49, 51, 52); sternum unmodified (Fig. 41); metasomal segment I subsessile to petiolate with second (Fig. 21); sternite II with elongate, well-developed felt line; ventral mandibular tooth present, but small; notauli present, but limited to distal half of mesoscutum; flagellomere I longer than wide, not like pedicel.

*Female*.—Unknown.

*Distribution*.—Southwestern U.S., Mexico.

*Hosts*.—*Auplopus* Spinola.

### *Sphaerophthalma (Photopsioides)*

Schuster 1958:36

Type-species: *Agama uro* Blake

*Male*.—Head slightly wider than mesosoma; marginal cell length equal to or slightly longer than stigma; ventral tooth of mandible usually small; eyes subovate, margins entire; eyes and ocelli large, bulging, compound eye touching base of mandible, posterior margin of compound eye less than greatest diameter of eye from posterolateral angle of head; sternum unmodified (Fig. 41); metasomal segment I petiolate with second (Fig. 21); felt line absent on sternite II; with conspicuous plumose setae; cuspis spatulate, dilated distally, bearing plumose setae; setae white or golden throughout.

*Female*.—Head as wide as mesosoma; integument of head and mesosoma punctate; mandible with a single tooth within, emarginate beneath, with prominent sub-basal tooth; eyes subovate and entire; genal carina absent; mesosoma pyriform, widest anteriorly, gradually narrowed posteriorly; anterior and propodeal spiracles not tuberculate; metasomal segment I petiolate with second (Fig. 21); felt line on tergite II only; plumose setae throughout, but lacking area of short dense white setae on dorsum of petiole; antennal scrobe carinate dorsally; flagellomere II slightly less than  $2\times$  ( $1.8\times$ ) length of first; propodeum short, length in lateral view  $\leq 0.5\times$  height; pygidial area undefined laterally.

*Distribution*.—Western U.S., Mexico.

*Hosts*.—*Ancistrocerus* Wesmael, *Anthocopa* Lepeletier, *Ashmeadiella* Cockerell, *Dianthidium* Cockerell, *Hoplitis* Klug, *Lep-tochilus* Saussure, *Pachodynerus* Saussure, *Sapyga* Latreille, and *Trypargilum* Richards.

### *Sphaerophthalma (Photopsis)* Blake

1871:258

Type-species: *Agama imperialis* Blake

*Male*.—Head slightly wider than mesosoma; marginal cell distinctly elongate,

much longer than stigma; mandible distinctly tridentate, ventral tooth of mandible often large; eyes subovate, margins entire; notauli not deep, lines wider than deep; sternum unmodified (Fig. 41); coxa often armed; metasomal segment I petiolate with second (Fig. 21); felt line absent on sternite II; with conspicuous plumose setae; cuspis never spatulate or dilated distally, never bearing plumose setae; pygidium and hypopygium distinctly elongate.

*Female*.—Head as wide as mesosoma; integument of head and mesosoma punctate; mandible emarginate beneath, but without sub-basal tooth; eyes subovate and entire; genal carina present to absent; mesosoma pyriform, widest anteriorly, gradually narrowed posteriorly; anterior and propodeal spiracles not tuberculate; metasomal segment I petiolate (Fig. 32) to sessile (Fig. 28) with second; felt line on tergite II only; plumose setae conspicuous; pygidium varying from defined laterally (Fig. 32) to undefined laterally (Fig. 28).

*Distribution*.—Western U.S., Mexico.

*Hosts*.—*Anthidium* Fabricius, *Anthophora* Fabricius, *Ashmeadiella* Cockerell, *Callanthidium* Cockerell, *Diadasia* Patton, *Euodynerus* Dalla Torre, *Isodontia* Patton, *Melissodes* Latreille, *Tachysphex* Kohl, and *Xeromelecta* Linsley.

*Sphaerophthalma (Physetapsis)* Schuster  
1958:20

Type-species: *Sphaerophthalma (Physetapsis) papaga* Schuster

*Male*.—Head slightly wider than mesosoma; marginal cell distinctly elongate, much longer than stigma; mandible bidentate or bidentate with minute median third tooth, acuminate distally, eyes subovate, margins entire; notauli deep, lines deeper than wide; sternum unmodified (Fig. 41); coxa often armed; metasomal segment I petiolate with second (Fig. 21); felt line of sternite II distinct; with conspicuous plumose setae; cuspis never spatulate or dilated distally, never bearing

plumose setae; pygidium and hypopygium distinctly elongate.

*Female*.—Unknown.

*Distribution*.—Southwestern U.S., into Canada.

*Hosts*.—Unknown.

*Stethophotopsis* Pitts, in Pitts and  
McHugh 2000:29

Type-species: *Stethophotopsis maculata* Pitts

*Male*.—Eyes entire, moderately protuberant; ocelli small; clypeal base tuberculate; mandible tridentate apically, ventral margin with a slight excision, not subtended by a distinct sub-basal tooth (Fig. 45); antennal scrobes carinate above, lacking a tubercle; notauli absent or obscure on anterior third of mesoscutum; mesosternum armed with pair of triangular tapering processes, originating near midline immediately anterior to mesocoxae, and appearing to cup anterior margin of mesocoxae, covered with dense simple setae; metasomal segment I petiolate with second (Fig. 21); felt line present on sternite II; plumose setae present; cuspis elongate, basal portion cylindrical, distal portion dilated and weakly concave on ventral surface.

*Female*.—Head narrower than mesosoma; integument of head and mesosoma punctate; mandible with a single tooth within, slightly emarginate beneath, with sub-basal tooth; eyes subovate and entire; genal carina absent; mesosoma pyriform, widest anteriorly, slightly narrowed posteriorly; anterior and propodeal spiracles not tuberculate; metasomal segment I petiolate with second (Figs. 21, 33); felt line on tergite II only; plumose setae on apical margins of metasomal segments; antennal scrobe inconspicuously carinate dorsally; flagellomere II 1.1x length of first; propodeum short, length in lateral view  $\leq 0.5x$  height; pygidial area undefined laterally.

*Distribution*.—Arizona.

*Hosts*.—Unknown.

*Timulla* Ashmead 1899:55

Type-species: *Mutilla dubitata* Smith

*Male*.—Compound eyes emarginate (Figs. 53, 54); metasomal segment I sessile with second (Figs. 20, 53); humeral angles rounded; felt line on tergite II only; axilla present; notauli present and conspicuous.

*Female*.—Eyes strongly ovate; mesosoma long, rectangular in shape, generally narrowed medially (Fig. 27); Metasomal segment I sessile with second (Figs. 20, 53); felt line on tergite II only.

*Distribution*.—Throughout much of western hemisphere.

*Hosts*.—*Beubix* Fabricius.

## ACKNOWLEDGMENTS

We thank Joseph McHugh and Cecil Smith (Department of Entomology, University of Georgia, Athens, GA), and Theresa Pitts-Singer (USDA Forest Service, Athens, GA) for reviewing this manuscript. JPP thanks Denis Brothers (University of Natal, Pietermaritzburg, South Africa) and K. V. Krombein (USNM) for answer questions concerning this project; Lynn Kimsey and Phil Ward (UCDC), Ted Schultz (USNM), R. R. Snelling (LACM), J. T. Huber (CNCI), E. R. Hoebeke (CUIC) and C. A. Olson (UAIC) for loan of specimens; P. J. Clausen (UMSP) for loan of specimens and copies of C. E. Mickel's notes; assistance provided by M. A. Farmer and J. A. Shields (Center of Ultrastructural Studies, University of Georgia); and the University of Georgia, College of Agricultural and Environmental Sciences, Department of Entomology for financial support.

## LITERATURE CITED

- André, E. 1903. Mutillidae. *Genera Insectorum*, Bruxelles, 1:1-77.
- Ashmead, W. H. 1896. Descriptions of new parasitic Hymenoptera. *Transactions of the American Entomological Society* 23:179-182.
- Ashmead, W. H. 1899. Super-families in the Hymenoptera and generic synopses of the families Thynnidae, Myrmosidae and Mutillidae. *Journal of the New York Entomological Society* 7:45-60.
- Blake, C. A. 1871. Synopsis of the Mutillidae of North America. *Transactions of the American Entomological Society* 3:217-265.
- Blake, C. A. 1886. Monograph of the Mutillidae of North America. *Transactions of the American Entomological Society* 13:179-286.
- Bradley, J. C. 1917. Contributions toward a monograph of the Mutillidae and their allies of America North of Mexico. IV. A review of the Myrmosidae. *Transactions of the American Entomological Society* 43:247-290.
- Brothers, D. J. 1975. Phylogeny and classification of the aculeate Hymenoptera, with special reference to Mutillidae. *University of Kansas Science Bulletin* 50:483-648.
- Brothers, D. J. 1989. Alternative life-history styles of mutillid wasps (Insecta, Hymenoptera), pp. 279-291. In: Bruton, M. N. (ed.), *Alternative Life-History Styles of Animals*. Kluwer Academic Publishers, Dordrecht.
- Brothers, D. J. 1993. Family Mutillidae, pp. 188-203. In: Goulet, H. and J. T. Huber (eds), *Hymenoptera of the world: An Identification Guide to the Families*. Centre for Land and Biological Resources Research, Ottawa, Ontario.
- Brothers, D. J. 1995. Mutillidae, pp. 541-548. In: Hanson, P. E. and I. D. Gauld (eds), *The Hymenoptera of Costa Rica*. Oxford University Press, Oxford.
- Cambra, R. A., and D. Quintero. 1997. A revision of *Protophopsis* Schuster (Hymenoptera: Mutillidae). *Journal of Hymenoptera Research* 6:263-272.
- Casal, O. H. 1970. *Chasququilla malincha*, género y especie nuevos para la entomofauna Argentina (Hymenoptera: Mutillidae). *Revista de la Sociedad Entomológica Argentina* 32:111-113.
- Ferguson, W. E. 1967. Male sphaerophthalmine mutillid wasps of the Nevada test site. *Brigham Young University Science Bulletin, Biological Series* 8:1-26.
- Fox, W. J. 1899. The North American Mutillidae. *Transactions of the American Entomological Society* 25:219-292.
- Fritz, M. A., and A. Martinez. 1975. Mutillidae Neotropicales. IV. (Hymenoptera) Un genero y especie nuevos de Sphaerophthalminae. *Physis*. 34: 129-132.
- Krombein, K. V. 1939. Studies in the Tiphidae IV. A revision of the Myrmosinae of the New World with a discussion of the Old World species (Hymenoptera Aculeata). *Transactions of the American Entomological Society* 65:415-465.
- Krombein, K. V. 1954. Taxonomic notes on some wasps from Florida with descriptions of new species and subspecies. *Transactions of the American Entomological Society* 80:1-27.
- Krombein, K. V., P. D. Hurd, Jr., D. R. Smith, and B. D. Burks. 1979. *Catalog of Hymenoptera in America North of Mexico*. Smithsonian Institution Press, Washington, D. C. 2735 pp.
- Latreille, P. A. 1796. Précis des caractères génériques des Insectes. *Brive*. p.118.
- Lelej, A. S., and P. G. Nemkov. 1997. Phylogeny, evolution and classification of Mutillidae (Hymenoptera). *Far Eastern Entomologist* 46:1-24.
- Manley, D. G. 1999. Synonymy of *Dasytmulla nocturna* Mickel (Hymenoptera: Mutillidae). *Pan-Pacific Entomologist* 74:18-22.
- Matthews, R. W. 1997. Unusual sex allocation in a

- solitary parasitoid wasp, *Sphaerophthalma pensylvanica* (Hymenoptera: Mutillidae) *Great Lakes Entomologist* 30:51–54.
- Mickel, C. E. 1928. Biological and taxonomic investigations on the Mutillid wasps. *U. S. National Museum Bulletin* 143:1–351.
- Mickel, C. E. 1935. Descriptions and records of nearctic Mutillid wasps of the genera *Myrmilloides* and *Pseudomethoca* (Hymenoptera: Mutillidae). *Transactions of the American Entomological Society* 61: 383–398.
- Mickel, C. E. 1936a. New species and records of nearctic Mutillid wasps of the genus *Dasymutilla* (Hymenoptera). *Annals of the Entomological Society of America* 29:29–60.
- Mickel, C. E. 1936b. Two new genera and five new species of Mutillidae. *Annals of the Entomological Society of America* 29:289–297.
- Mickel, C. E. 1937. The Mutillid wasps of the genus *Timulla* which occur in North America North of Mexico. *Entomologica Americana* 17:1–119.
- Mickel, C. E. 1940. Two new species of *Lomachaeta*, with a key to described species. *Pan-Pacific Entomologist* 16:127–131.
- Mickel, C. E. 1963. Description of the female of *Dilophotopsis stenognathus* Schuster (Hymenoptera: Mutillidae). *Pan-Pacific Entomologist* 39:183–184.
- Mickel, C. E. 1964. A new genus and species of Mutillidae from California (Hymenoptera: Mutillidae). *Pan-Pacific Entomologist* 40:108–110.
- Nonveiller, G. 1990. Catalog of the Mutillidae, Myrmosidae and Bradynobaenidae of the neotropical region including Mexico. *Hymenopterorum Catalogus*, Pars 18:1–150.
- Pitts, J. P., and J. V. McHugh. 2000. *Stethophotopsis*, a new genus of Sphaerophthalmini (Mutillidae: Sphaerophthalminae) with a brachypterous male from Arizona. *Journal of Hymenoptera Research* 9: 29–33.
- Say, T. 1836. Descriptions of new North American Hymenoptera, and observations on some already described. *Boston Journal of Natural History* 1:295–298.
- Schuster, R. M. 1946. A revision of the Sphaerophthalmine Mutillidae of America North of Mexico. *Annals of the Entomological Society of America* 39: 692–703.
- Schuster, R. M. 1949. Contributions toward a monograph of the Mutillidae of the neotropical region, III. A key to the subfamilies represented and descriptions of several new genera (Hymenoptera). *Entomologica Americana* 29:59–140.
- Schuster, R. M. 1951. A revision of the genus *Epluta* (Mutillidae) in America North of Mexico. *Journal of the New York Entomological Society* 59:1–43.
- Schuster, R. M. 1952. Notes on North America Mutillidae II. Some new species of the genus *Photomorphus*. *Bulletin of the Brooklyn Entomological Society* 47:53–64.
- Schuster, R. M. 1956. A revision of the genus *Epluta* (Mutillidae) in America North of Mexico. Part II. Species group *grisea*. *Journal of the New York Entomological Society* 64:7–84.
- Schuster, R. M. 1958. A revision of the Sphaerophthalmine Mutillidae of America North of Mexico. II. *Entomologica Americana* 37:1–130.
- Viereck, H. L. 1902. Hymenoptera from southern California and New Mexico, with descriptions of new species. *Proceedings of the Academy of Natural Sciences of Philadelphia* 54:728–743.
- Viereck, H. L. 1903. A group of diurnal Mutillidae. *Entomological News* 14:249–251.
- Wasbauer, M. S. 1973. Some new taxa in the Myrmosinae with keys to the females in North America. *Pan-Pacific Entomologist* 49:325–337.

## Descriptions and Biology of Nine New Species of *Arpactophilus* (Hymenoptera: Crabronidae), with a Key to Described Australian Species

ROBERT W. MATTHEWS AND IAN D. NAUMANN

(RWM) Department of Entomology, University of Georgia, Athens, GA 30602, USA  
(e-mail: rmatthew@uga.edu);

(IDN) Division of Entomology, C.S.I.R.O., PO Box 1700, Canberra, ACT 2601, Australia  
(e-mail: ian.naumann@affa.gov.au)

---

*Abstract.*—The following new species of *Arpactophilus* are described: *A. deakinus*, *A. platycephalus*, *A. similus*, *A. flavifrons*, *A. magneticus*, *A. kakaduensis*, *A. transversus*, *A. termes*, and *A. hursti*. This brings the total number of named Australian species to 22. An illustrated key to the females of described Australian *Arpactophilus* species is provided and a **lectotype** for *A. steindachneri* Kohl is designated. Biological information is presented for each of the new species plus *A. reticulatus* (Turner). Extended parental care and progressive provisioning are the hallmark of this genus, with known species displaying a range of habits from solitary (4 species) to possibly eusocial (a nest of *A. termes* contained 19 adults and 33 cells). *Arpactophilus reticulatus* appears to be the most generalized, and was found nesting in stem cavities of five plant species across a broad range of habitats. It was parasitized by a generalist eupelmid wasp, *Calosota* sp. Four species used empty galls of a gelechiid moth, *Sphaleractis parasitica* Meyrick, on geebung, *Persoonia falcata* (Proteaceae). Five other species nested in old beetle tunnels in slender twigs of various trees and shrubs. Psyllid nymphs were the usual prey, but *A. transversus* also preyed upon cicadellid nymphs. All species appear to have multiple generations per year where weather conditions permit.

---

*Arpactophilus* is an Australasian genus of predatory wasps remarkable among Apoidea (Melo 1999) for their high level of social behavior (Matthews and Naumann 1988). Presently, 13 species are recorded from Australia. However, material in collections indicate that there exists a spectacular array of more than 60 undescribed species (Naumann, unpublished). The genotype, *A. bicolor* Smith (1864), was described from Misool, an island near the western end of New Guinea, which remains the westernmost locality of the genus outside Australia. Menke (1989) described three new *Arpactophilus* species from New Guinea, and stated that there were several undescribed species represented in the collections of the Bishop Museum, distributed from New Guinea to

Fiji, including New Britain, New Caledonia, and the Solomon Islands. Recently, Bohart (1999) described 17 new species from New Caledonia with a key to females from material taken by Malaise traps.

Bohart and Menke (1976) synonymized *Austrostigmus* Turner (1912) under *Arpactophilus*, commenting that the characters used by Turner to distinguish it from *Arpactophilus* were variable and intergraded with those of typical *Arpactophilus*. Menke (1989) reviewed the diagnostic characters of the genus and provided detailed notes on morphological variation present among the species. In addition, he placed it in a separate new subtribe of the Pemphredoninae, the Spilomenina, together with the closely related *Spilomena*, *Micros-*

*tigmus*, and *Xysma* (see also Menke 1997, p. 251).

This paper describes nine distinctive new Australian *Arpactophilus* and provides a key to females of all the named Australian species. Biological data for each of the new species plus one previously named are also presented.

#### METHODS

Morphological terminology largely follows Bohart and Menke (1976). Terminol-

ogy for microsculpture follows Harris (1979) and Eady (1968). Biological studies were conducted on Magnetic Island, near Townsville, Queensland from October to December, 1998, in Deakin, a suburb of Canberra, A.C.T. in January and February 1999, and in Kakadu National Park, east of Darwin, Northern Territory in May 1999. Unless otherwise noted, all specimens and nests from this study are deposited in the Australian National Insect Collection (ANIC) in Canberra, Australia.

---

#### KEY TO DESCRIBED AUSTRALIAN ARPACTOPHILUS (FEMALES)

1. Second submarginal cell triangular and anteriorly appendiculate or stalked (Fig. 1) . . . . . *queenslandensis* (Turner)
  - Second submarginal cell trapezoidal or cubical, or if triangular, not distinctly stalked (Figs. 2 and 3) . . . . . 2
2. Head strongly flattened; pronotum greatly elongated and mesosoma dorsoventrally strongly compressed (Figs. 17-19 and 21-22) . . . . . 3
  - Head globular to elongate, not at all flattened; pronotum transverse, not elongated and mesosoma not markedly compressed dorsoventrally . . . . . 4
3. Clypeal free margin cream yellow to orange red; second submarginal cell trapezoidal . . . . . *similis* sp. nov.
  - Clypeus entirely black; second submarginal cell nearly triangular . . . *platycephalus* sp. nov.
4. Body entirely black or dark brown, except occasionally tegula and/or pronotal lobe lighter . . . . . 15
  - Body (excluding legs and antennae) marked with yellow, red-orange, or cream, at least on the clypeal apical margin . . . . . 5
5. Mesosoma at least partly red/orange . . . . . 6
  - Mesosoma entirely black, or at most with only the pronotal lobe lighter . . . . . 7
6. Pronotum red/orange, contrasting sharply with black mesonotum . . . . . *ruficollis* (Turner)
  - Pronotum anterior to pronotal carina mostly black . . . . . *kakaduensis* sp. nov.
7. Head marked with yellow or red/orange or cream color, at least on clypeal free margin . . . . . 8
  - Head entirely black . . . . . 9
8. Lower face to middle of eyes yellow; gena extensively yellow . . . . . *tricolor* (Turner)
  - Yellow facial markings confined mostly to clypeus; gena with yellow restricted to region surrounding mandiblar socket . . . . . *flavifrons* sp. nov.
9. Pronotal carina prominent, elevated, distinctly separated from mesoscutum, with anterolateral margins acutely angulate (Fig. 64); free clypeal margin distinctly cream colored . . . . . *lursti* sp. nov.
  - Pronotal carina low, sometimes thin and bladelike, closely appressed to mesoscutum, with anterolateral margin rounded; free clypeal margin black or nearly so . . . . . 10
10. Body length less than 4 mm; vertex microreticulate to finely punctate; distance from lateral ocellus to eye distinctly less than distance between lateral ocelli (Fig. 33) . . . . . *magneticus* sp. nov.
  - Body length greater than 5 mm; vertex coarsely sculptured, often with prominent striation; distance from lateral ocellus to eye equal to or greater than distance between lateral ocelli (Fig. 4) . . . . . 11

11. Frontal carina expanded into an acute projection on frons (Fig. 5) . . . . . *arator* (Turner)  
 – Frontal carina not forming an acute projection, although sometimes expanded blade-like between scapes . . . . . 12
12. First recurrent vein received by first submarginal cell (Fig. 2) . . . . . *sulcatus* (Turner)  
 – First recurrent vein more or less interstitial or inserting on second submarginal cell (Fig. 3) . . . . . 13
13. Mesoscutellum longitudinally striate (Fig. 6) . . . . . *deserticolus* Turner  
 – Mesoscutellum microreticulate with sparse setigerous punctures (Fig. 7) . . . . . 14
14. Pronotal carina bladelike, distinctly separated from the mesoscutum . . . *steindachneri* Kohl  
 – Pronotal carina closely appressed or barely separated from mesoscutum . . . *kohlui* (Turner)
15. Mandible strongly angulate at base and broadened just before apex (Fig. 8) . . . . .  
 . . . . . *mimi* Naumann  
 – Mandible not as above, curved at base and gradually narrowing toward apex . . . . . 16
16. Occipital carina complete dorsally (Fig. 53) . . . . . 17  
 – Occipital carina incomplete, evanescent or interrupted dorsally . . . . . 18
17. Pedicel length about half that of first flagellomere; clypeal margin not serrated; mesoscutal sculpture rugose with large, irregularly spaced, crater-like punctures (Fig. 9) . . . . .  
 . . . . . *reticulatus* (Turner)  
 Pedicel length subequal to that of first flagellomere; mesoscutal sculpture reticulate rugose (Fig. 57) . . . . . *termes* sp. nov.
18. Mesoscutum with distinct transverse carinulae (Figs. 47–48); gena strongly strigose (Fig. 45) . . . . .  
 . . . . . *transversus* sp. nov.  
 – Mesoscutum mostly finely punctate; gena sculpture variable, but not strongly strigose . . . . . 19
19. Frontal carina raised, forming a translucent lamella between antennal scrobes . . . . .  
 . . . . . *dubius* (Turner)  
 – Frontal carina low, barely raised between antennal scrobes . . . . . 20
20. Pronotal carina not especially raised, the anterolateral margin smoothly rounded, not at all projecting (Fig. 11); genal carina present . . . . . *dcakinus* sp. nov.  
 – Pronotal carina strongly raised, anterolateral margin angulate; genal carina absent . . . . . 21
21. Anterior veinlet of the second submarginal cell as long as 2r-m cross vein, the second submarginal cell nearly quadrate; stigma brown . . . . . *glabrellus* (Turner)  
 – Anterior veinlet of the second submarginal cell distinctly shorter than 2r-m cross vein, the second submarginal cell more trapezoidal; stigma yellow-brown . . . . .  
 . . . . . *approximatus* (Turner)

## TAXONOMY

The ANIC collection of *Arpactophilus* has been sorted into over 60 provisional species, most of which are unique or represented by only a few specimens, usually females. Based on this material, Menke's (1988) comments on morphological variation within the genus can be augmented for the Australian fauna as follows.

Head shape varies from globular to quadrate to elongate and flattened. Postocellar area may be long or short, and broadly emarginate to transverse as viewed dorsally. Head sculpture, like that of the mesonotum and propodeum, varies

from nearly smooth, to finely punctate, to distinctly striate, to coarsely rugose areolate. A well-developed carina may be present or absent on the gena. Clypeal free margin varies from broadly rounded to medially strongly emarginate. Labral free margin varies from entire to broadly bilobed to multidentate (2, 4 or 6 teeth). Frontal carina varies from strong to weak, and takes a variety of forms above the clypeus from dorsally bifurcated to lamellate to ventrally spinose. Additionally, it may extend a variable distance onto the clypeus and is sometimes flanked by submedian carinae.

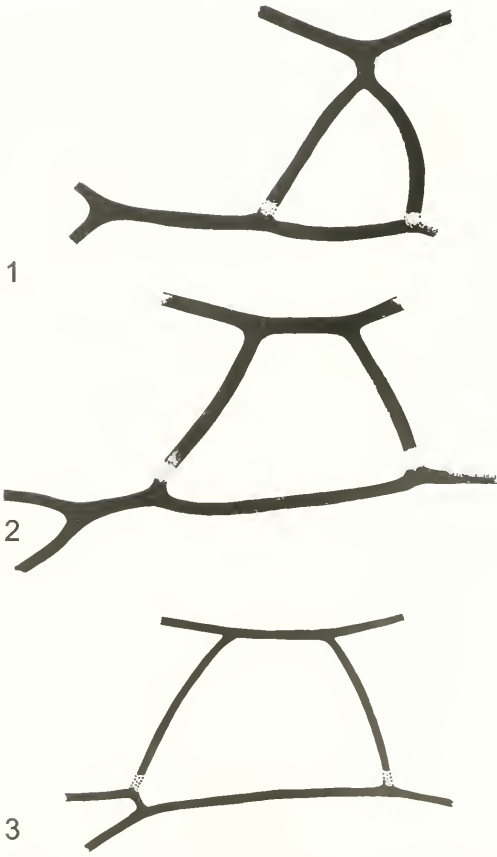

Figs. 1–3. *Arpactophilus*, second submarginal cell of right fore wing. 1, *A. queenslandensis*. 2, *A. sulcatus*. 3, *A. deserticolus*. All drawn to same scale.

Pronotal collar varies from elongate (nearly as long as the mesoscutellum) to short, knifelike and closely appressed to mesoscutum. The transverse pronotal carina sometimes forms a bladelike lamella, either distinctly separated from mesoscutum or closely appressed to it. In dorsal view the carina may be straight, gently curved or broadly v-shaped, and the anterolateral margin varies from acutely angulate to gently rounded.

Forewing venation differs as illustrated in Figs. 1–3. In particular, the shape of the second submarginal cell varies from anteriorly broad, to narrow, to stalked, and the insertion of the first recurrent vein varies from the first submarginal, to interstitial, to the second submarginal. Menke

(1988) also noted specimens from New Caledonia and Solomon Islands with only a single submarginal cell, and Bohart (1999) described four species with one submarginal cell from New Caledonia. There are at least two species in Australia with only one submarginal cell (one collected nr. Herberton, Qld, Australian Museum Collection, other from Surveyors Pool, WA in ANIC). Finally, the marginal cell varies from apically rounded to acuminate.

Terga I and II vary from smooth to sparsely punctate, to extensively microreticulate. Sternum VI in females varies from entire to subdivided into a medioternite flanked by two laterosternites. Male genitalia have not yet received detailed study, as males are generally uncommon in collected material. However, Dollfuss (1983) found genitalic characters of considerable taxonomic value in the closely related genus *Spilomena*, which suggests that those of *Arpactophilus* will likely also prove useful.

Color varies from entirely black to pale except for a black head. Red/orange or pale straw occurs variably on either the mesosoma or metasoma or both. Many species have the lower face and part of the gena marked with yellow. So far none of the extensively pale species have been described. Interestingly, labels on several of these specimens state that they were taken at light.

*Arpactophilus deakinus* Matthews and Naumann, sp. nov.

(Figs. 10–16; Table 1)

*Type material*.—Holotype ♀, 35.19S 149.06E, Deakin, A.C.T., 24-i-99, R. W. Matthews, Bio. Note 187, in ANIC. Paratypes: 9 ♀♀, one ♂, all same locality as holotype (dates and notes are 31-i-99, note 200a; 6-ii-99, note 206; 24-i-99, note 187; 20-iii-99, note 206, cell 3; 27-ii-99, note 206, cell 2), one ♂, 28.22S 153.05E, Brindle Ck., NSW, Border Ras NP, 14-ii-84, I. D. Naumann, ex ethanol, all in ANIC.

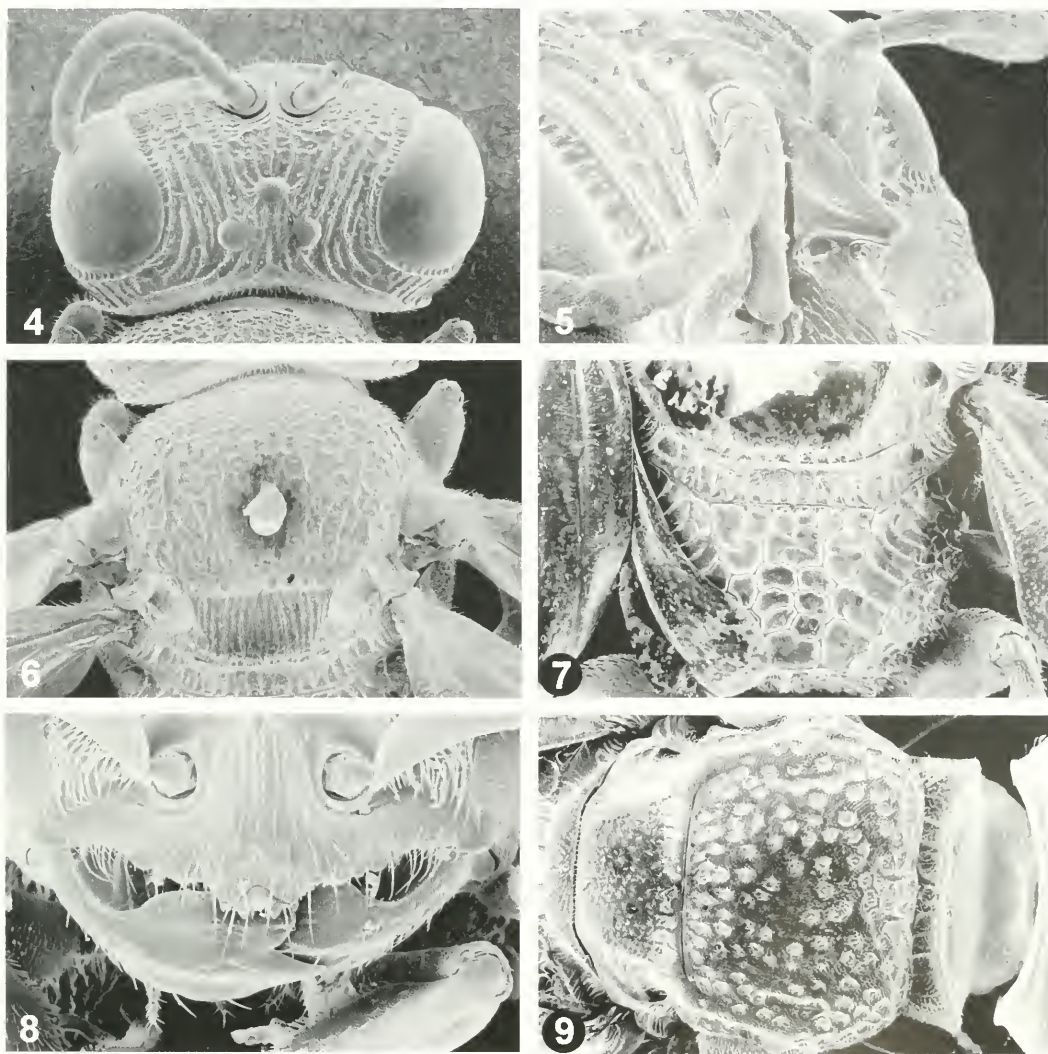

Figs. 4–9. *Arpactophilus*. 4, *A. deserticolus*, head of holotype, dorsal view (48 $\times$ ). 5, *A. arator*, face of holotype showing spinose projection above clypeus (72 $\times$ ). 6, *A. deserticolus*, mesosoma of holotype, dorsal view (44 $\times$ ). 7, *A. kohlii*, mesoscutellum and propodeum of holotype, dorsal view (54 $\times$ ). 8, *A. mimi*, lower face and mandibles (100 $\times$ ). 9, *A. reticulatus*, mesosoma dorsal view (130 $\times$ ).

*Female*.—Measurements and ratios as in Table 1. *Head*: Globular, without long post-ocellar area. Vertex and face uniformly moderately punctate (Fig. 11), interspaces finely microreticulate. Occipital carina strong laterally, evanescent dorsally. Gena (Fig. 12) microreticulate, becoming strigose to crenulate along genal carina. Genal carina present, but fading ventrally

before reaching mandibular sockets. Antennal scrobes well defined, microreticulate to faintly transversely costulate. Frontal carina fine, low and distinct, extending from median ocellus onto about 2/3 length of clypeus (Fig. 11). Circumocular groove narrow and weakly crenulate along inner orbits, becoming crenulate along outer orbits. Clypeus finely micro-

Table 1. Measurement data for nine new *Arpactophyllus* species holotypes. (Note: Other than body and wing length, ratios only should be used for comparisons, as measurement units differed across species.) Explanation of abbreviations: BL = length of body (excluding antennae); FWL = length of forewing (apex to tegula); HH = maximum height of head (from vertex to clypeal free margin); HL = maximum length of head (measured at right angles to HH); HW = maximum width of head; UFW = distance between compound eyes measured at level of anterior ocellus; LFW = distance between compound eyes measured just below antennal sockets; POL = minimum distance between lateral ocelli; OOL = minimum distance between lateral ocellus and compound eye; VOL = longitudinal distance between lateral ocelli and back of head (as seen in vertical view); OD = maximum diameter of lateral ocellus; SL = scape length; SW = scape width; FIL = length of first flagellomere; F1W = width of first flagellomere; PL = pedicel length; MSW = maximum width of mesoscutum; MSL = length of mesoscutum (as seen in vertical view).

	<i>hursti</i> sp. nov.	<i>transversum</i> sp. nov.	<i>termes</i> sp. nov.	<i>kakaducensis</i> sp. nov.	<i>iniqueticus</i> sp. nov.	<i>flavifrons</i> sp. nov.	<i>sanitius</i> sp. nov.	<i>platicephalus</i> sp. nov.	<i>denkims</i> sp. nov.
BL (mm)	5.0	5.1	4.1	3.2	3.0	3.5	4.4	4.4	4.6
FWL (mm)	3.0	2.7	2.1	2.1	2.1	2.3	2.6	2.5	3.5
HH	28	33	25	18	19	22	27	26	35
HL	17	20	15	13.5	12	13	5	5	19
HW	37	30	30	20.5	19	25	28	27	34
UFW	20	11.5	13	9	8	11	15	15	19
LFW	25	21	14	12	9	14	19	17	19
POL	4	1.5	3.5	2	2	2.5	4	4	4
OOL	5.5	2.5	3	1.5	2	3	4.5	5	5
VOL	6	10	7	4	5	6	2	2	15
OD	3	2	2	1.5	1.5	1.5	1.5	1.5	3
SL	10	12	10	7	7	8	6.5	7	9
SW	3	3	3	2	2	2	2.5	2	3
FIL	6	7	4	2	2	5	3.5	3	4
F1W	4	5	3.5	2	2	2.5	3	3	3
PL	5	6	5	5	5	6	5	5	8
MSW	30	27	25	17.5	16	19	23	19	29
MSL	20	18	16	12	11	12	13	13	21

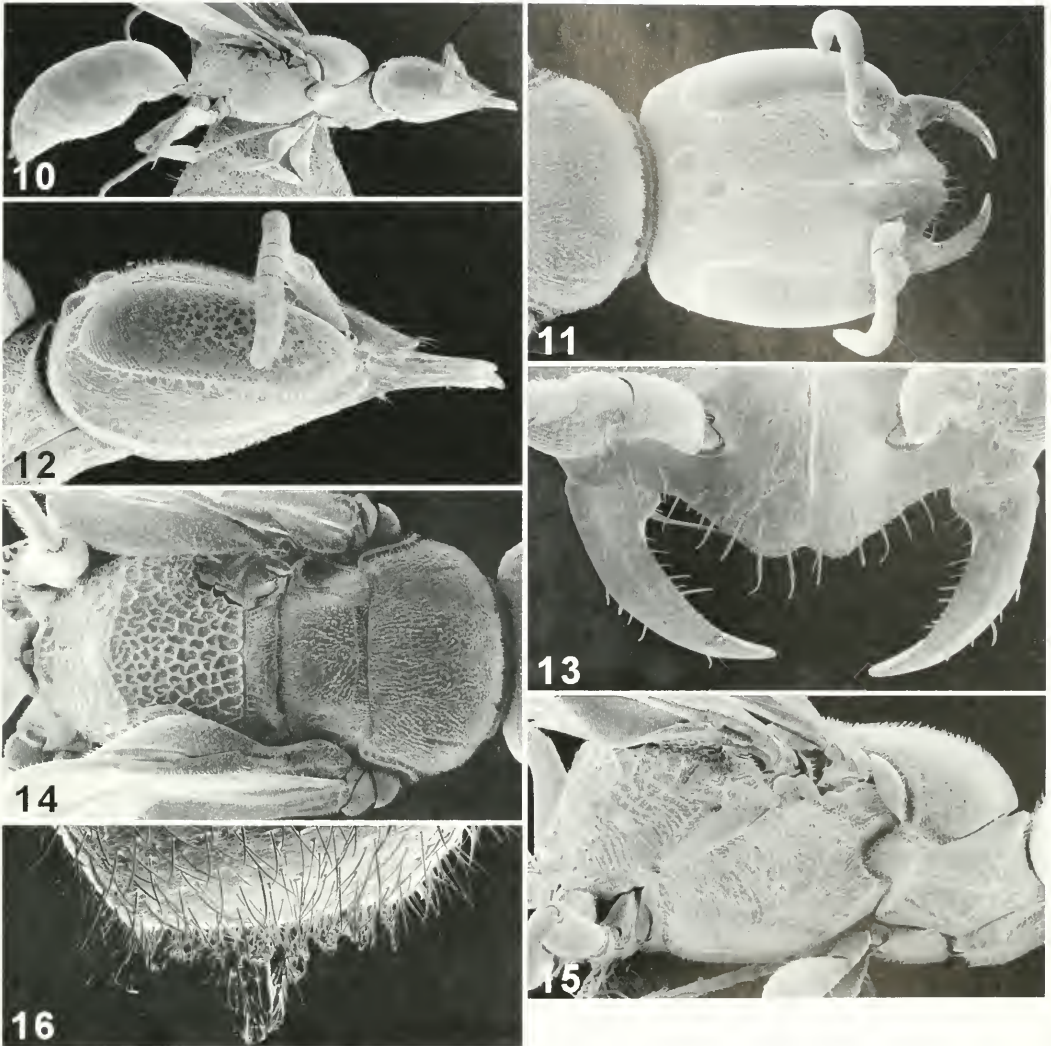

Figs. 10–16. *Arpactophilus deakinus*, paratype female. 10, Body, lateral (36×). 11–12, Head, frontal (66×) and lateral (110×). 13, Lower face, clypeal margin and mandibles (160×). 14–15, Mesosoma, dorsal (66×) and lateral (94×). 16, Dorsal view of apex of tergum 6 (220×).

reticulate, narrowly emarginate apically (Fig. 13). Labrum with four uniformly spaced teeth, the outer ones slightly smaller and more pointed. Mandible evenly curved, bidentate apically, the outer tooth about twice as long as inner tooth. *Antenna*: Scape and flagellomeres stout; first flagellomere nearly half as long as pedicel and only slightly longer than wide. Scapal length equal to pedicel plus first 3 flagellomeres. *Mesosoma*: Pronotal carina a low

keel (Figs. 11,12, and 15), distinctly separated from anterior margin of mesoscutum by about width of first flagellomere at its narrowest point, curving slightly anteriorly laterally, but lacking angulate anterolateral margin, posteriorly longitudinally striate, most apparent laterally. Mesoscutum (Fig.14) convex, uniformly covered with fine, closely spaced setigerous punctures, interspaces finely microreticulate; parapsidal lines distinct, well de-

fined; notauli evident at anterior margins, but less distinct than parapsidal lines. Sculpture of mesoscutellum and metanotum essentially same as mesonotum; prescutellar sulcus narrow. Mesopleuron (Fig. 15) posteriorly obliquely costulate/coriaceous; hypersternaulus distinct, crenulate, narrow, broadening posteriorly; omaulus present, acetabular carina absent; metapleuron clothed with short hairs, obscuring microsculpture. Propodeum uniformly areolate rugose (Fig. 14); posterior face transversely strigose costulate with a small central dorsal smooth area bounded by a Y-shaped carina whose base extends to metasomal insertion. *Forewing*: Second submarginal cell narrowed anteriorly, trapezoidal; first recurrent vein received by submarginal I; M beyond 2r-m absent. *Metasoma*: Terga 1 and 2 smooth, shining, with widely scattered setigerous punctures. T2–5 uniformly faintly microreticulate. T6 apically truncate with dense brush of short setae (Fig. 16). *Color*: Head, mesosoma, and metasoma black, non-metallic. Antenna, mouthparts, tegula, legs (except coxae) orange/red. Coxae black basally, suffused with red/orange distally. Forewing hyaline, venation yellow over basal half; stigma and distal veins brown.

*Male*.—Identical to female in size, sculpture, and color. Paramere broad, apically blunt, glabrous except for short setae over apical area. Aedeagus strongly curved and pointed apically, nearly as long as paramere. Cuspis triangular, flattened, about half length of paramere, with a slight twist along longitudinal axis. Digitus about  $0.85\times$  cuspis, slightly swollen and setose apically.

*Etymology*.—The specific name refers to the Canberra suburb where the type specimen was collected, and is a noun in apposition.

*Diagnosis*.—This species appears to be most similar to *A. glabrellus* (Turner) known only from W. Australia. It differs in being larger and entirely black (*A. glabrellus* mesosoma and metasoma are a

deep mahogany brown). The second submarginal cell is more trapezoidal in *A. deakinus*, with the second abscissa of Rs + M about equal to anterior veinlet of submarginal II, whereas it is distinctly shorter in *A. glabrellus*. Finally, *A. deakinus* has a much more extensively sculptured propeodeal hindface, which is nearly smooth and glabrous in *A. glabrellus*, and a much more uniformly punctate mesopleuron than does *A. glabrellus*.

*Arpactophilus platycephalus* Matthews and Naumann, sp. nov.

(Figs. 17–22; Table 1)

*Type material*.—Holotype ♀, 19.09S 146.52E, Arcadia Magnetic Is. QLD, 27-xi-98, R. W. Matthews, Reared ex gall of *Sphaleractis* sp. on *Persoonia falcata*, Note 114, cell 2, in ANIC. Paratypes: 3 ♀♀, all same locality as holotype (dates and notes are 8-xi-98, note 115; 27-xi-98, note 115, cell 1; 8-xi-98, note 114); one ♀ Jim Jim Creek, 19km WSW of Mt. Cahill, N.T., 24-x-72, D. H. Colless. One paratype in Queensland Museum; others in ANIC.

*Female*.—Measurements and ratios as in Table 1. *Head*: Strongly flattened, elongate, almost prognathous. Vertex and face uniformly faintly microreticulate (Fig. 18). Occipital carina strong laterally, joining hypostomal carina ventrally, absent dorsally. Hypostoma with scattered fine setigerous punctures, interspaces microreticulate. Gena (Fig. 19) very narrow, faintly microreticulate, genal carina barely evident. Antennal scrobes shallow, indistinct, sculpture continuous with face. Frontal carina fine, low and distinct, not extending onto clypeus, flanked by very fine short carinae on either side at level of antennal sockets. Circumocular groove absent. Postocellar area very short, less than half distance between lateral ocelli, and broadly concave posteriorly in dorsal view. Clypeus flattened, medially shining to very faintly microreticulate apically and laterally, broadly emarginate apically (Fig. 20). Labrum with six uniformly spaced teeth.

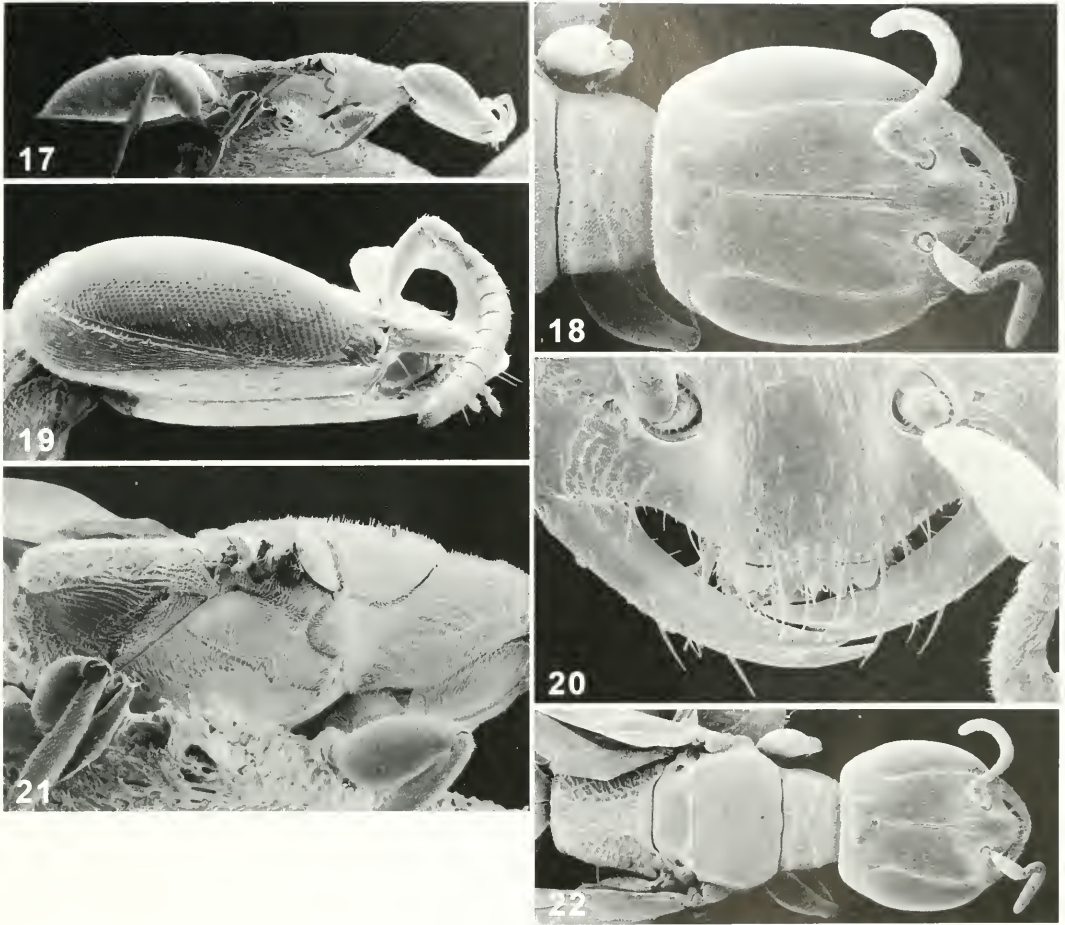

Figs. 17–22. *Arpactophilus platycephalus*, paratype female. 17, Body, lateral (26×). 18–19, Head, frontal (110×) and lateral (100×). 20, Lower face, clypeal margin, labrum, and mandibles (300×). 21, Mesosoma, lateral (86×). 22, Head and mesosoma, dorsal (60×).

Mandible evenly curved, bidentate apically, the outer tooth distinctly longer than inner tooth. *Antenna*: Scape and flagellomeres slender; first flagellomere slightly longer than half of pedicel and about as long as wide. Scape short, not quite reaching mid orbit, length equal to pedicel plus first 2 flagellomeres. *Mesosoma*: Pronotum elongate, flattened, much narrower than head and mesoscutum. Pronotal carina crossing at about half of pronotal length, slightly raised, forming a “v” medially as seen in dorsal view (Figs. 18, 22), lateral and dorsal portions posterior to carina weakly longitudinally striate, faintly transversely

strigose anterior to carina medially. Mesoscutum (Figs. 21, 22) extremely flattened, uniformly finely microreticulate, becoming very faintly longitudinally striate along posterior margin; parapsidal lines and notauli absent. Sculpture of mesoscutellum and metanotum essentially same as mesonotum; prescutellar sulcus narrow and crenulate. Mesopleuron (Fig. 21) with episternal sulcus curving posteriorly to become continuous with hypersternaulus as a rather broad crenulate furrow; acetabular carina absent. Propodeum areolate rugose, interspaces faintly microreticulate, the dorsal face with 4 somewhat

more pronounced oblique longitudinal carinae, two lateral, two more medial, converging posteriorly (Fig. 22); posterior face short, about half as long as dorsal face, with a medial carina extending ventrally from a small shining triangular area, otherwise microreticulate with a few weak irregular carinae laterally, and three evenly spaced, barely apparent weak tubercles along posterior lateral margins. *Forewing*: Second submarginal cell narrowed anteriorly, triangular, essentially lacking the anterior veinlet; first recurrent vein received by submarginal I; second abscissa of Rs + M subequal to basal veinlet of submarginal II; M distinctly evident beyond 2r-m. *Metasoma*: Terga 1 and 2 smooth, shining, with widely spaced minute setigerous punctures. T3–5 uniformly faintly microreticulate. T6 smooth, shining, rounded apically, with a dense brush of very short whitish setae along apical margin. S6 with several golden setae that are distinctly longer than any other sternal setae. *Color*: Head, mesosoma, and metasoma black, non-metallic. Antennae, mouthparts, legs (including coxae) orange/red. Forewing hyaline, venation including stigma uniformly straw yellow.

*Male*.—Unknown.

*Etymology*.—The specific name is in reference to the distinctive head shape (Fig. 19).

*Diagnosis*.—This species belongs to a unique group in the genus characterized by the strongly dorsoventrally compressed head and body and elongate prothorax, the latter reminiscent of *Nitela*. Its closest relative appears to be *A. similis* sp. n., from which it differs by having the head entirely black and submarginal II triangular.

*Arpactophilus similis* Matthews and Naumann, sp. nov.

(Table 1)

*Type material*.—Holotype ♀, 12.51S 132.48E, Kakadu NP, Northern Territory, Nourlangie Rock, 16-v-99, R. W. Mat-

thews, ex gall of *Sphaleractis* sp. on *Per-soonina falcata*, Note 260, in ANIC. Paratypes: 3 ♀♀, all same locality as holotype (dates and notes are 18-v-99, note 254; 22-v-99, note 265; 22-v-99, note 265a). All in ANIC.

*Female*.—Measurements and ratios as in Table 1. *Head*: Strongly flattened, almost prognathous. Vertex and face uniformly faintly microreticulate. Occipital carina strong laterally, joining hypostomal carina ventrally, absent dorsally. Hypostoma with widely scattered fine punctures, the interspaces microreticulate; gena faintly microreticulate, genal carina present, fading toward mandibular socket. Antennal scrobes shallow, indistinct, sculpture continuous with face. Frontal carina fine, low and distinct, not extending onto clypeus, flanked by 2–4 very fine short carinae on either side at level of antennal socket. Circumocular groove absent. Postocellar area very short, about half of distance between lateral ocelli, and broadly concave posteriorly in dorsal view. Clypeus flattened, faintly microreticulate, narrowly emarginate apically. Labrum with six uniformly spaced teeth. Mandible evenly curved, bidentate apically, the outer tooth distinctly longer than inner tooth. *Antenna*: Scape and flagellomeres slender; first flagellomere slightly longer than half of pedicel and about as long as wide. Scape short, not quite reaching mid orbit, length equal to pedicel plus first 2 flagellomeres. *Mesosoma*: Pronotum elongate, flattened, much narrower than head and mesoscutum. Pronotal carina crossing at about half of pronotal length, strongly raised, forming a “v” medially as seen in dorsal view; lateral face posterior to carina longitudinally striate; dorsal face posterior to carina rugose changing to longitudinally striate along anterior margin of mesoscutum; central part anterior to “v” slightly swollen, microreticulate. Mesoscutum extremely flattened, uniformly finely microreticulate, lateral margins along tegulae narrowly crenulate; parapsidal lines present, in-

distinct; notauli absent. Sculpture of mesoscutellum and metanotum essentially same as mesonotum; prescutallar sulcus narrow and with 7 evenly spaced carinulae. Mesopleural central area faintly rugose to microreticulate; episternal sulcus curving posteriorly to become continuous with hypersternaulus as a relatively deep furrow; acetabular carina absent. Propodeum areolate rugose, the interspaces faintly microreticulate, the dorsal face with 4 somewhat more pronounced oblique longitudinal carinae, two lateral, two more medial, converging posteriorly; posterior face short, about half as long as dorsal face, with a medial longitudinal carina arising at propodeal insertion, forking to form a "y" dorsally, the two arms of the fork forming the posterior margin of the dorsal face and curving around to form a slight tubercle on each lateral margin, otherwise microreticulate above to rugulose below. *Forewing*: Second submarginal cell slightly narrowed anteriorly, trapezoidal, the anterior veinlet slightly longer than the second abscissa of Rs + M; first recurrent vein received well into submarginal I; M barely evident beyond 2r-m. *Metasoma*: Terga 1–6 uniformly faintly microreticulate. T6 rounded apically with a dense brush of very short whitish setae along apical margin. S6 with several golden setae distinctly longer than any other sternal setae. *Color*: Body black, non-metallic, except clypeus below antennal sockets orange/red. Antennae, mouthparts, legs (including coxae), and pronotal lobes orange/red. Forewing hyaline; venation including stigma uniformly straw yellow.

*Male*.—Unknown.

*Etymology*.—The specific name is in reference to the close similarity to *A. platycephalus*.

*Diagnosis*.—This species seems closely related to *A. platycephalus*. It is most readily distinguished by the orange/red clypeus and the trapezoidal shape of the second submarginal cell.

*Arpactophilus flavifrons* Matthews and Naumann, sp. nov.

(Figs. 23–29; Table 1)

*Type material*.—Holotype ♀, 19.09S 146.52E, Arcadia Magnetic Is. QLD, 8-xi-98, R. W. Matthews, reared ex burrow in *Lophostemon grandiflorus*, Note 90, in ANIC. Paratypes: 2 ♀♀, 1 ♂, all same locality as holotype (dates and notes are: 28-x-98, reared ex burrow in *Lophostemon grandiflorus*, Note 90; 8-xi-98, ex bamboo; 14-xii-98, ex bamboo, Note 182), one paratype in Queensland Museum, remainder in ANIC.

*Female*.—Measurements and ratios as in Table 1. *Head*: Globular. Face irregularly longitudinally strigose confused reticulate (Fig. 24), with a well-defined but irregular longitudinal carina flanking eye inner orbit. Frontal carina straight, low and distinct, extending from median ocellus to mid clypeus where it forks, the branches nearly reaching clypeal free margin. Vertex (Fig. 26) becoming faintly transversely strigose posteriorly. Occipital carina strong laterally, evanescent dorsally. Gena (Fig. 25) microreticulate; genal carina well developed, crenulate. Antennal scrobes well defined, microreticulate. Circumocular groove narrow and weakly crenulate along outer orbits, disappearing at inner orbits. Clypeus finely microreticulate, apically nearly truncate (Fig. 27). Labrum broad, truncate apically, lacking teeth. Mandible slender, evenly curved, bidentate apically, the outer tooth about twice as long as inner tooth. Eyes with scattered short hairs (Figs. 24–26). *Antenna*: Flagellomeres slender relative to scape; first flagellomere nearly as long as pedicel and twice as long as wide. Scapal length equal to pedicel plus first 2 flagellomeres. *Mesosoma*: Pronotal carina raised (Figs. 28–29), distinctly separated from anterior margin of mesoscutum by about width of first flagellomere, anterolateral margin rounded, not strongly angulate, space between carina and anterior margin of me-

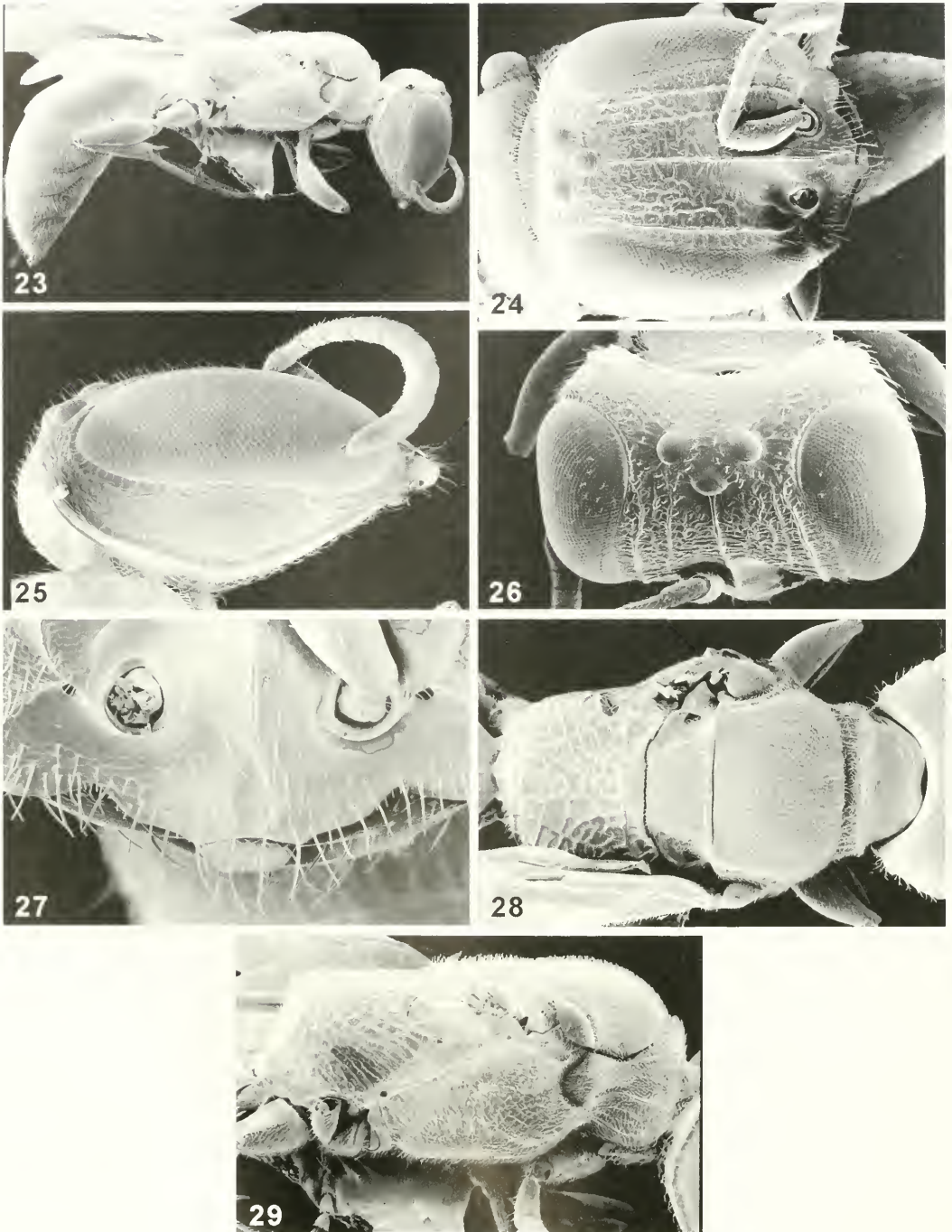

Figs. 23–29. *Arpactophilus flavifrons*, paratype female. 23, Body, lateral (48 $\times$ ). 24–26, Head, frontal (120 $\times$ ), lateral (130 $\times$ ), and dorsal (120 $\times$ ). 27, Lower face, clypeal margin, and labrum (320 $\times$ ). 28–29, Mesosoma, dorsal (110 $\times$ ) and lateral (100 $\times$ ).

soscutum longitudinally striate. Mesoscutum (Fig. 28) convex, uniformly covered with fine setigerous punctures, except lateral margin along tegula crenulate; parapsidal lines present, somewhat indistinct; notauli well defined. Sculpture of mesoscutellum and metanotum essentially same as mesonotum; prescutellar sulcus narrow and with a well defined median carina. Mesopleuron (Fig. 29) irregularly weakly strigose; hypersternaulus indistinct, a shallow depression broadening posteriorly, and weakly crenulate; acetabular carina absent. Propodeum uniformly areolate rugose (Fig. 28); lateral face longitudinally strigose anteriorly, becoming areolate rugose dorsally; posterior face transversely strigose on either side of a median y-shaped carina whose base extends to metasomal insertion. *Forewing*: Second submarginal cell narrowed anteriorly, trapezoidal; first recurrent vein inserting on first submarginal cell; second abscissa of Rs + M slightly longer than anterior veinlet of second submarginal cell; M barely evident beyond 2r-m. *Metasoma*: Tergites smooth, shining, very faint microreticulation laterally on T3–6. T6 apically rounded with dense brush of short setae. *Color*: Head black except yellow clypeus and around mandibular sockets, extending slightly onto gena and along lower inner orbit. Mesosoma black, except pronotal lobe and anterior margin of pronotum cream. Metasoma red/orange, except ovipositor sheaths brown. Scape and mouthparts yellow, flagellum brown. Legs (including coxae) yellow. Forewing hyaline, veins and stigma light brown.

*Male*.—Identical to ♀ in size, sculpture, and color, except that yellow on head is more extensive, reaching to just beyond middle of orbit on both gena and frons and entire hypostomal area. Pedicel and first two flagellomeres are orange/red, remainder of flagellum becoming dark brown. Tarsomere 5 light brown. Genitalia not studied.

*Etymology*.—The specific name refers to the extensive yellow on the male's face.

*Diagnosis*.—The truncate toothless labrum is distinctive, as is the color pattern on the head, the presence of the adorbital carina, and the forked frontal carina. *Arpactophilus tricolor* has somewhat similar facial coloration, but more extensive yellow in the female (male unknown). In *A. tricolor* the metasoma is black, whereas it is red in *A. flavifrons*. *Arpactophilus magneticus* is superficially similar with well-defined adorbital carinae, and it nests in the same place. However, the form of the labrum, frontal carina, and pronotal carina differ markedly, and the head is entirely black.

*Arpactophilus magneticus* Matthews and Naumann, sp. nov.

(Figs. 30–36; Table 1)

*Type material*.—Holotype ♀, 19.09S 146.52E, Arcadia Magnetic Is. QLD, 28-x-98, R. W. Matthews, reared ex burrow in *Lophostemon grandiflorus*, Note 85, in ANIC. Paratypes: 9 ♀♀, 2 ♂♂, all same locality as holotype (dates and notes are: 13-x-98, 16-xi-98, reared ex burrow in *Mallotus phillipensis*, Note 2; 15-x-98, 26-x-98, ex burrow in *Lophostemon grandiflorus*, Note 76; 24-x-98, ex burrow in *Lophostemon grandiflorus*, Note 85; 3-xii-98, ex burrow in *Neolitsia australiensis*, Note 170; 6-xii-98, ex burrow in *Mallotus phillipensis*, Note 172), two paratypes: in Queensland Museum, remainder in ANIC.

*Female*.—Measurements and ratios as in Table 1. *Head*: Globular. Face microreticulate becoming weakly transversely wrinkled dorsally, with evenly spaced short erect hairs, and with a well-defined longitudinal carina flanking each inner orbit (Fig. 31). Frontal carina straight, low and distinct, not quite reaching median ocellus and barely extending onto clypeus. Vertex (Fig. 33) becoming faintly transversely strigose posteriorly. Occipital carina strong laterally, evanescent dorsally. Gena (Fig. 32) shining, faintly longitudi-

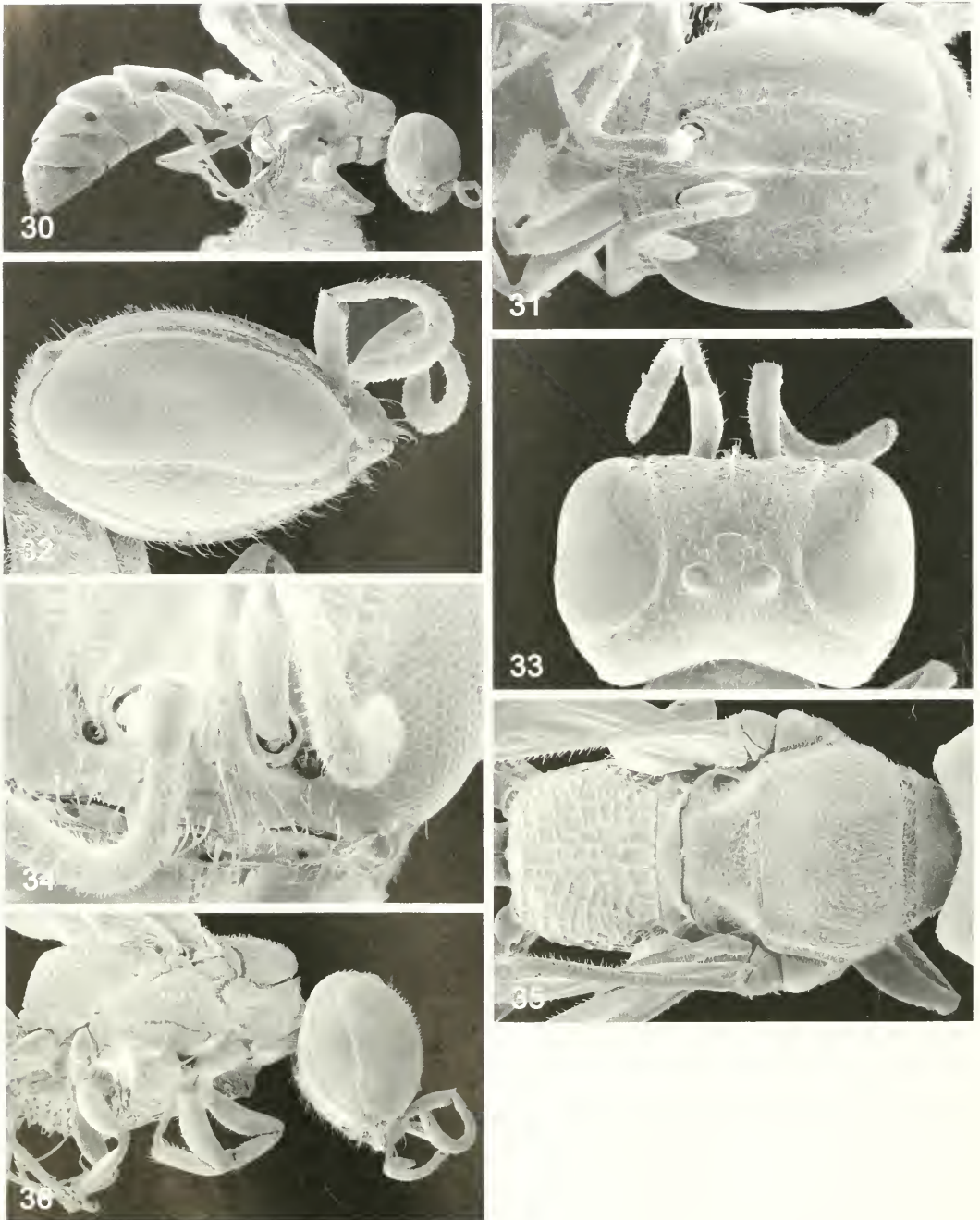

Figs. 30–36. *Arpactophilus magneticus*, paratype female. 30, Body, lateral (30 $\times$ ). 31–33, Head, frontal (160 $\times$ ), lateral (160 $\times$ ), and dorsal (180 $\times$ ). 34, Lower face, clypeal margin, and mandibles (300 $\times$ ). 35, Mesosoma, dorsal (160 $\times$ ). 35, Mesosoma and head, lateral (86 $\times$ ).

nally strigose; genal carina well developed. Antennal scrobes weakly defined, smooth to faintly microreticulate. Circumocular groove very narrow and indistinct posteriorly, absent anteriorly. Clypeus (Fig. 34) smooth, apically broadly rounded, with scattered elongate setae, twice as long as those on frons. Labrum with 4 evenly spaced short teeth (Fig. 34). Mandible slender, evenly curved, bidentate apically, the outer tooth about twice as long as inner tooth. *Antenna*: Flagellomeres short and stout, more or less quadrate (Fig. 32); first flagellomere nearly half as long as pedicel and as wide as long. Scapal length equal to pedicel plus first 4 flagellomeres. *Mesosoma*: Pronotal carina (Fig. 35) low, not especially raised and barely separated from anterior margin of mesoscutum, anterolateral margin rounded, not at all angulate, laterally the space between carina and anterior margin of mesoscutum longitudinally striate. Pronotal collar anterior to carina microreticulate. Mesoscutum (Fig. 35) convex, uniformly covered with fine setigerous punctures, except lateral margin along tegula crenulate; parapsidal lines present, somewhat indistinct; notauli indistinct. Sculpture of mesoscutellum and metanotum essentially same as mesonotum; prescutellar sulcus narrow with a well-defined median carina. Mesopleuron (Fig. 36) dorsally irregularly wrinkled weak rugose, with fine setigerous punctures, becoming microreticulate centrally; hypersternaulus a weakly crenulate shallow depression broadening posteriorly; acetabular carina absent. Propodeum areolate rugose (Fig. 35); lateral face longitudinally strigose anteriorly, the interspaces microreticulate, becoming areolate rugose dorsally; posterior face transversely strigose on either side of a median longitudinal carina. *Forewing*: Second submarginal cell broad anteriorly, nearly quadrate; first recurrent vein inserting on the very end of first submarginal cell, essentially interstitial; M barely evident beyond 2r-m. *Metasoma*: Terga

smooth, shining, very faint microreticulation laterally on T3–6. *Color*: Head and mesosoma black. Metasoma red/orange. Antenna, mouthparts, and legs (including coxae) red/orange. Forewing hyaline, veins and stigma light brown.

*Male*.—Similar to female in size, sculpture, and color, except lower two-thirds of face clothed with dense silvery pubescence and adorbital carina absent. Eyes more strongly convergent above, the ratio of LFW:UFW 12:7. Fore and middle legs, mouthparts and antenna yellow, the last flagellomere brown. Genitalia not studied.

*Etymology*.—The specific name is in reference to the type locality, Magnetic Island, Queensland.

*Diagnosis*.—This species is superficially similar to *A. flavifrons* and nests in the same habitat, but differs in several important respects, notably the lack of yellow on the lower face and the forewing venation. Additionally, the presence of silver facial pubescence in the male face is unusual as this occurs only rarely in other species (e.g., *A. kakaduensis*) where the male is known.

*Distribution*.—In addition to the type locality, specimens in the ANIC have been taken at Mt. Spec, Qld., Gordonvale, Qld., Bald Knob State Forest, NSW, and Otford, NSW.

***Arpactophilus kakaduensis* Matthews  
and Naumann, sp. nov.**  
(Figs 37–41; Table 1)

*Type material*.—Holotype ♀, 12.51S 132.48E, Kakadu NP, Northern Territory, Nourlangie Rock, 16-v-99, R. W. Matthews, ex gall of *Sphaleractis* sp. on *Persoonia falcata*, Note 244, in ANIC. Paratypes: 38 ♀♀, 12 ♂♂, all same locality as holotype (dates and notes are: 16-v-99, note 244, two ♀♀, one ♂; 16-v-99, note 243a, one ♀; 16-v-99, note 243b, one ♀, one ♂; 17-v-99, note 246a, one ♀; 17-v-99, note 246b, one ♀; 17-v-99, note 247, two ♀♀, one ♂; 18-v-99, note 256, 5 ♀♀; 22-v-99, note 266 unassociated with nests, 20

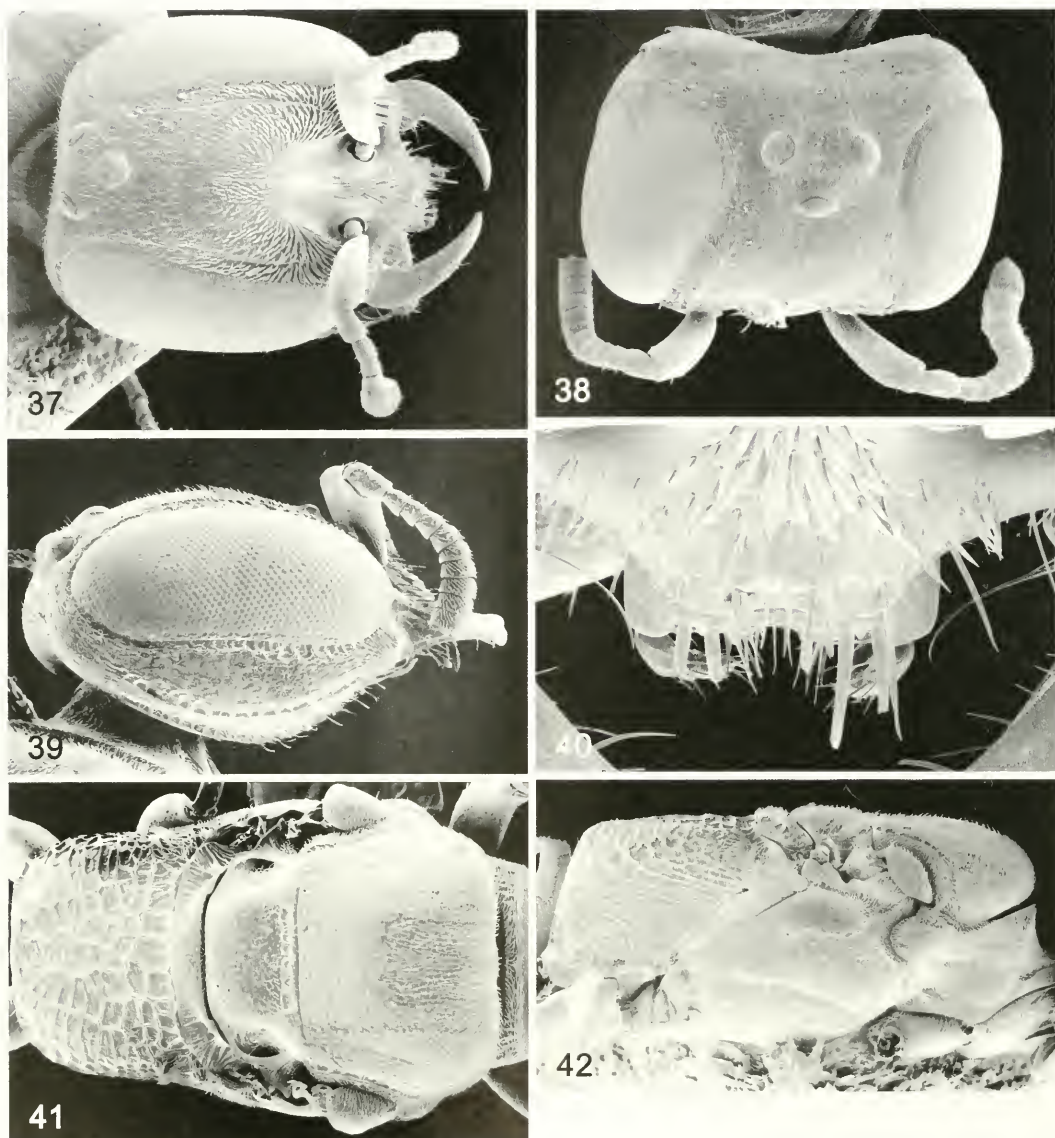

Figs. 37–42. *Arpactophilus kakaduensis*, paratype female. 37–39, Head, frontal (120 $\times$ ), dorsal (160 $\times$ ), and lateral (150 $\times$ ). 40, Clypeal margin and labrum (540 $\times$ ). 41–42, Mesosoma, dorsal (150 $\times$ ) and lateral (94 $\times$ ).

♀♀, 5 ♂♂; 22-v-99, note 266a, two ♀♀; 22-v-99, note 266b, one ♀, one ♂; 22-v-99, note 266c, one ♂; 22-v-99, note 266d, one ♀; 22-v-99, note 266e, one ♀; 22-v-99, note 266g, one ♂; 22-v-99, note 266h, one ♂), all in ANIC, except two in Queensland Museum.

*Female*.—Measurements and ratios as in Table 1. *Head*: Globular. Face uniformly

covered with fine setigerous punctures (Figs. 37–38), the setae short and erect. Frontal carina straight, low and indistinct, extending from below median ocellus barely onto clypeus, section between antennal scrobes slightly raised, lamellate, with very small but distinct tubercle. Vertex (Fig. 38) sparsely finely punctate around ocelli, becoming faintly microreti-

culate posteriorly; distance between lateral ocelli distinctly greater than distance between lateral ocellus and eye; posterior margin of vertex concave in dorsal view. Occipital carina evident laterally, evanescent dorsally. Gena (Fig. 39) somewhat shining, faintly longitudinally strigose to microreticulate; genal carina crenulate, well developed posteriorly, fading toward mandibular socket. Antennal scrobes deep grooves, smooth to faintly microreticulate. Circumocular groove very narrow and crenulate, disappearing at mid face. Clypeus (Figs. 37 and 40) smooth, somewhat convex and apically broadly truncate, with numerous short flattened setae basally. Labrum broad with 6 to 8 closely-spaced short teeth, and with 6 short stiff apical setae (Fig. 40). Mandible slender, evenly curved, bidentate apically, the outer tooth only slightly longer than inner. *Antenna*: Flagellomeres short and stout, more or less quadrate (Figs. 38–39); first flagellomere nearly half as long as pedicel and as wide as long. Scapal length equal to pedicel plus first 4 flagellomeres. Last flagellomere slightly flattened distally. *Mesosoma*: Pronotal carina (Figs. 41–42) low, not at all raised and barely separated from anterior margin of mesoscutum, anterolateral margin rounded. Pronotal collar anterior to carina microreticulate to faintly longitudinally strigose. Mesoscutum (Fig. 41) convex, uniformly covered with fine setigerous punctures, except lateral margin along tegula crenulate; parapsidal lines present, notauli indistinct. Sculpture of mesoscutellum and metanotum essentially same as mesonotum; prescutellar sulcus narrow with a well-defined median carina. Mesopleuron (Fig. 42) smooth to faintly punctate and clothed with short setae; hypersternaulus a narrow crenulate furrow, deepest anteriorly, continuous with episternal sulcus and ending before mid coxa; acetabular carina absent. Propodeum areolate rugose (Fig. 41), with four somewhat more prominent longitudinal carinae converging posteri-

orly; lateral face finely longitudinally reticulate striate, becoming areolate rugose dorsally; posterior face irregularly weakly reticulate rugose, framed by more prominent carinae along posterolateral and dorsal margins. *Forewing*: Second submarginal cell slightly narrowed anteriorly, approaching trapezoidal shape; first recurrent vein received at the end of submarginal I, second abscissa of Rs + M about one-fourth as long as the anterior veinlet of submarginal II. Vein M distinct, but barely evident beyond 1r-m. *Metasoma*: Terga smooth, shining, very faint microreticulation laterally on T3–6. T6 with well developed transverse brush of dense setae apically. *Color*: Head black except apical half of clypeus and area immediately surrounding mandibular socket cream yellow. Mesosoma predominantly red/orange, except pronotal collar anterior to carina black, and pronotal lobe cream yellow. Metasoma red/orange, the ovipositor sheaths black. Scape and mandibular base cream yellow, flagellae red/orange. Fore and middle legs light yellow; hind legs more red/orange. Forewing hyaline, veins and stigma light brown.

*Male*.—Similar to female in size, sculpture, and color, except most of face below median ocellus clothed with dense silvery pubescence. Eyes more strongly convergent above, the ratio of LFW:UFW 14:9. Genitalia not studied.

*Etymology*.—The specific name is in reference to the type locality, Kakadu National Park, Northern Territory.

*Diagnosis*.—The mesosomal coloration is distinctive, being predominantly red/orange with the anterior portion of the pronotum black. There are several unnamed species in ANIC with the mesosoma predominantly red/orange, with some areas black, but *A. kakaduensis* is the only one to have extensive black restricted to the pronotum. *Arpactophilus ruficollis* has the pronotum red and the mesonotum black. Additionally, the silver pubescence on the

male face of *A. kakaduensis* is distinctive, similar to that of *A. magneticus*.

*Arpactophilus transversus* Matthews and Naumann, sp. nov.  
(Figs 43–50; Table 1)

*Type material*.—Holotype ♀, 12.25S 132.57E, Obiri Rock, Kakadu NP, N. Territory, 21-xi-1979, I. D. Naumann, in ANIC. Paratypes: 2 ♀♀, same data as holotype, one ♀ N. Territory, Kakadu NP, L. Nourlangie Rock, 6-11-vi-1984, R. W. Matthews, all in ANIC.

*Female*.—Measurements and ratios as in Table 1. *Head*: Elongate, eyes strongly convergent dorsally. Face longitudinally striate (Fig. 43), lower two-thirds clothed with dense short silver gray setae. Frontal carina distinct, section between antennal scrobes slightly raised, lamellate, fading as it reaches clypeus. Postocellar area long (Fig. 44), VOL about 4× greater than OOL, microreticulate, grading to transversely microreticulate posteriorly; distance between lateral ocelli distinctly less than distance between lateral ocellus and eye. Occipital carina incomplete dorsally. Gena (Fig. 45) longitudinally striate; genal carina absent. Antennal scrobes deep grooves, transversely finely striate. Circumocular groove present along outer orbit, disappearing dorsally, then reappearing along the upper third of inner orbit. Clypeus (Fig. 46) broadly rounded apically and notched medially. Labrum with four evenly spaced teeth, lateral ones slightly broader and more rounded than medial ones. Mandible slender, evenly curved, bidentate apically, outer tooth only slightly longer than inner. *Antenna*: First flagellomere distinctly longer than pedicel (Fig. 43). Length of scape equal to pedicel plus first 4 flagellomeres. *Mesosoma*: Pronotal carina (Figs. 47–48) strongly raised, well separated from anterior margin of mesoscutum, lateral portion slightly curved anteriorly; anterolateral margin erect, sharply angulate. Mesoscutum (Fig. 48) convex, transversely coarsely strigose, lateral mar-

gins crenulate; parapsidal lines distinct short grooves, notauli present but indistinct. Mesoscutellum and metanotum nearly smooth to sparsely punctate, interspaces microreticulate. Prescutellar sulcus with 5 evenly spaced longitudinal carinae. Mesopleuron (Fig. 49) irregularly obliquely strigose, hypoepipimeral area broadly excavated with 4 oblique carinae; hypersternaulus continuous with episternaulus, forming a broad deep areolate furrow whose sculpture is continuous with surrounding area; acetabular carina present. Propodeum areolate rugose (Fig. 48); lateral face obliquely striate; posterior face (Fig. 50) with inverted triangular smooth area medio-dorsally, remainder irregularly transversely rugulose. *Forewing*. Second submarginal cell strongly narrowed anteriorly, nearly triangular; first recurrent vein received by submarginal I, second abscissa of Rs + M about equal to anterior veinlet of submarginal II. Vein M absent beyond 2r-m. *Metasoma*: T1 with sparse small setigerous punctures, except on basal half, otherwise shining, smooth; T2 covered with similar punctures over otherwise smooth, shining distal two-thirds, basal one-third uniformly microreticulate expanding to include most of lateral area; T3–6 microreticulate, strongest on T3. T6 more or less smooth, with scattered distinct punctures, a brush of short setae at apex. S6 with a row of 4 distinctly longer, erect setae on either side of midline towards apex. *Color*: Body black except pronotal lobes lighter brown yellow. Scape and mandible (except teeth) yellow, flagellum red/orange. Legs yellow, except coxae somewhat more orange. Forewing hyaline, veins and stigma very light brown.

*Male*.—Unknown.

*Etymology*.—The specific name refers to the transverse sculpture of mesoscutum.

*Diagnosis*.—In general facies this species resembles *A. termes*, and nests in a similar habitat. It differs in the more elongate head shape behind the orbits, the strongly

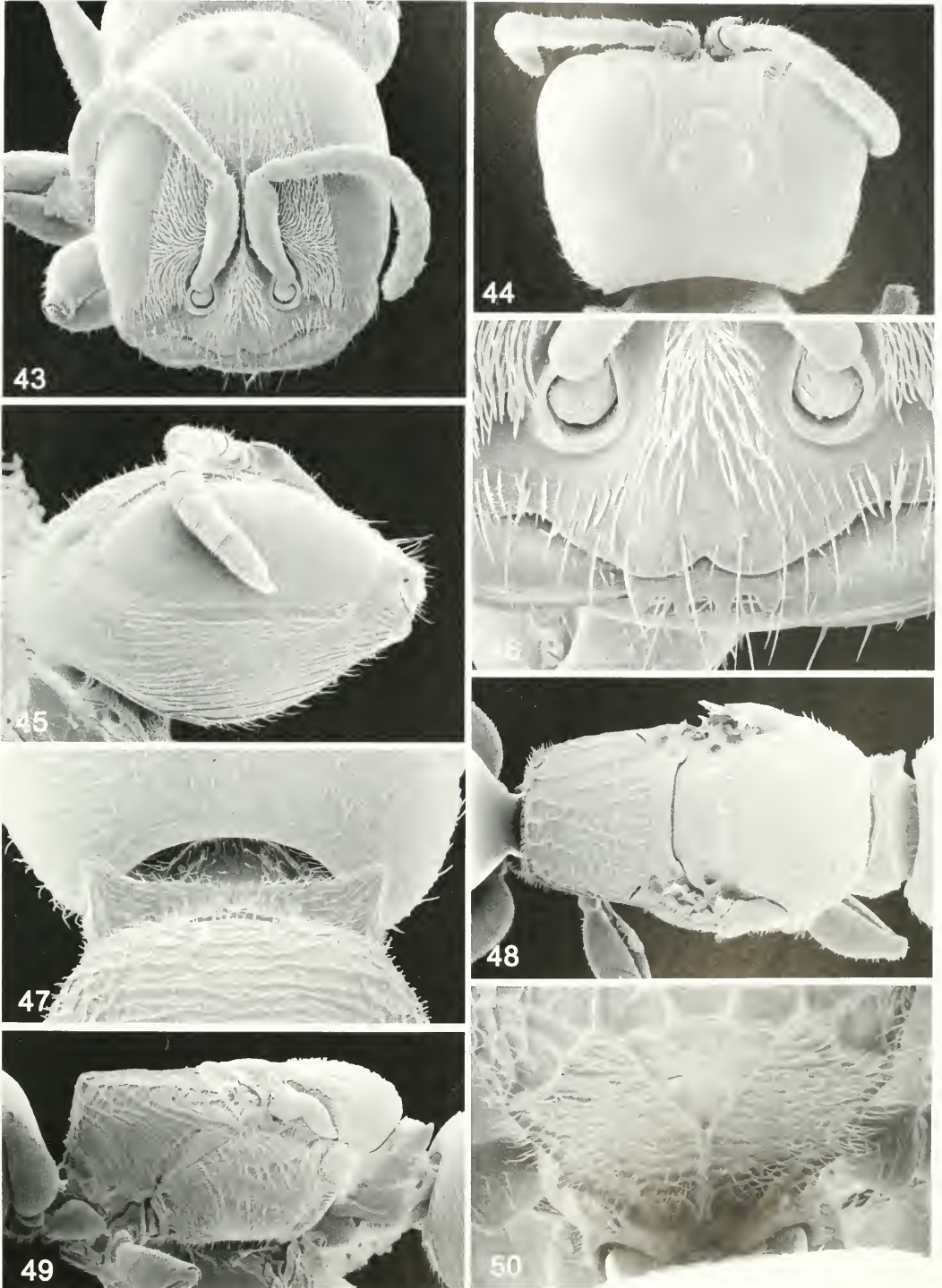

Figs. 43–50. *Arpactophilus transversus*, paratype female. 43–45, Head, frontal (54 $\times$ ), dorsal (72 $\times$ ), and lateral (60 $\times$ ). 46, Lower face, clypeal margin, and labrum (240 $\times$ ). 47, Pronotum, dorsal (72 $\times$ ). 48–49, Mesosoma, dorsal (48 $\times$ ) and lateral (48 $\times$ ). 50, Propodeum, posterior face (150 $\times$ ).

convergent eyes dorsally, striate gena, and transversely strigose mesonotum. It is the only species known to us to have predominantly transversely oriented mesoscutal sculpturing. The dense silver gray facial pubescence in females is also distinctive. This species was referred to as *Arpactophilus* sp. 48 in Naumann (1983).

*Arpactophilus termes* Matthews and  
Naumann, sp. nov.  
(Figs. 51–58; Table 1)

*Type material*.—Holotype ♀, 12.51S 132.48E, Kakadu NP, Northern Territory, Nourlangie Rock, 17-v-99, R. W. Matthews, ex old termite gallery, Note 245, in ANIC. Paratypes: 13 ♀♀, 5 ♂♂, all same data as holotype, all in ANIC.

*Female*.—Measurements and ratios as in Table 1. *Head*: Globular. Face rugose reticulate (Fig. 52), interspaces finely microreticulate, with more predominant longitudinal lateral carina more or less parallel to circumocular groove. Frontal carina distinct, section between antennal scrobes slightly raised, lamellate, fading as it reaches clypeus. Vertex (Fig. 53) coarsely rugose reticulate grading to transversely microreticulate posteriorly; distance between lateral ocelli subequal to distance between lateral ocellus and eye. Occipital carina complete, somewhat weaker dorsally. Gena (Fig. 54) irregularly strigose reticulate along carina, the interspaces microreticulate, becoming predominantly microreticulate along circumocular groove; genal carina well developed distinctly crenulate, fading toward mandibular socket. Antennal scrobes deep grooves, transversely striate. Circumocular groove complete, well defined, deep, and crenulate. Clypeus (Fig. 55) somewhat convex and flattened medially, microreticulate, broadly emarginate apically, the margin serrated. Mandible slender, evenly curved, bidentate apically, the outer tooth only slightly longer than inner. *Antenna*: Flagellomeres short and stout, more or less quadrate (Figs. 52 and 54); first fla-

gellomere subequal to pedicel. Scape length equal to pedicel plus first 4 flagellomeres. *Mesosoma*: Pronotal carina (Figs. 53 and 57) strongly raised, well separated from anterior margin of mesoscutum; anterolateral margin sharply angulate; posterior face deeply costulate. Mesoscutum (Fig. 57) convex, coarsely rugose reticulate, interspaces microreticulate, lateral margin crenulate; parapsidal lines deep short grooves; notauli indistinct. Mesoscutellum and metanotum with several coarse punctures, interspaces microreticulate. Mesopleuron (Fig. 56) irregularly rugose reticulate below microreticulate hypoepimeral area. Hypersternaulus continuous with episternaulus, their coarsely crenulate sculpture intergrading with remainder of mesopleuron; acetabular carina present. Propodeum areolate rugose, the interspaces microreticulate (Fig. 57), with 4 somewhat more prominent longitudinal carinae converging posteriorly; lateral face obliquely striate, interspaces finely microreticulate, becoming areolate rugose dorsally; posterior face (Fig. 58) weakly irregularly reticulate rugose, framed by more prominent carinae along dorsal and lateral margins. *Forewing*: Second submarginal cell strongly narrowed anteriorly, approaching triangular; first recurrent vein received by submarginal I, second abscissa of Rs + M nearly as long as anterior veinlet of submarginal II; vein M absent beyond 2r-m. *Metasoma*: T1 sparsely covered with small setigerous punctures, except on anterior medial area, otherwise shining, smooth; T2 sparsely covered with similar punctures over otherwise smooth, shining distal two-thirds, the basal one-third uniformly microreticulate extending to include most of lateral area; T3–6 uniformly microreticulate, strongest on T3. T6 more or less smooth with scattered distinct punctures, a brush of short setae at apex. *Color*: Body black except pronotal lobes light brown yellow. Scape and mandible (except teeth) yellow, flagellum red/orange. Legs yellow, except

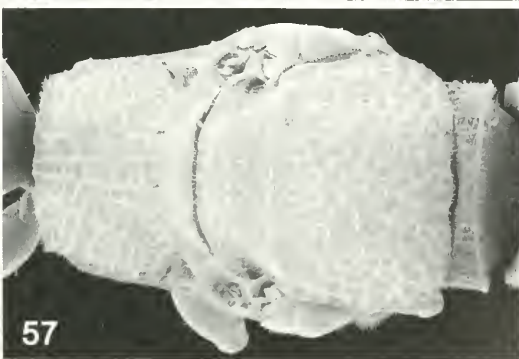
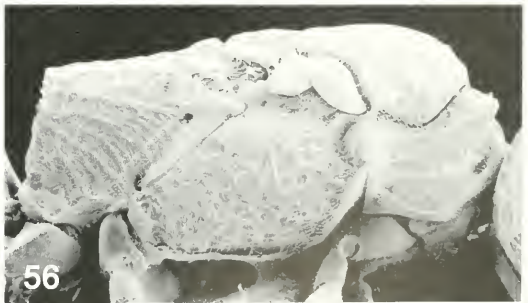
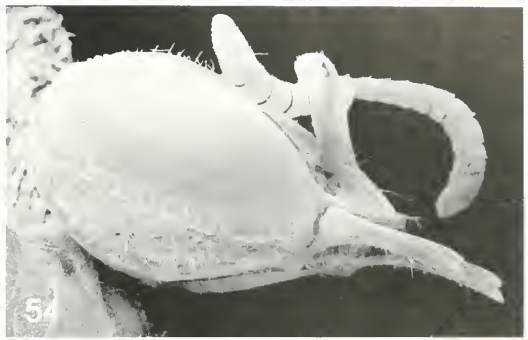
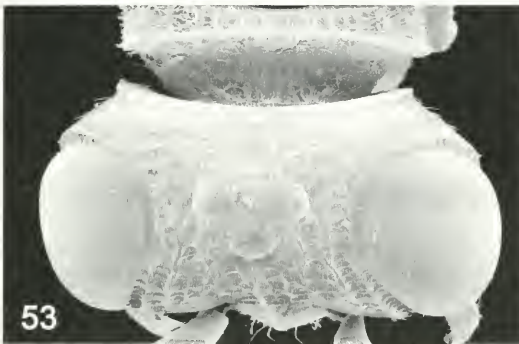
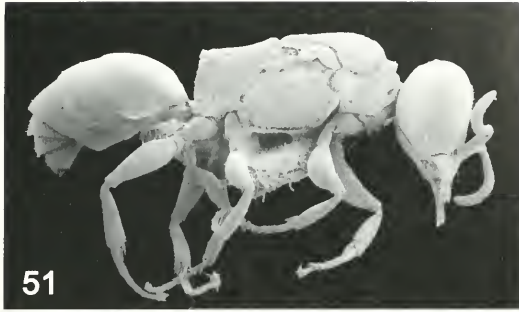

Figs. 51–58. *Arpactophilus termes*, paratype female. 51, Body, lateral (48 $\times$ ). 52–54, Head, frontal (86 $\times$ ), dorsal (150 $\times$ ), and lateral (110 $\times$ ). 55, Lower face, clypeal margin (200 $\times$ ). 56–57, Mesosoma, lateral (86 $\times$ ) and dorsal (110 $\times$ ). 58, Propodeum, posterior face (200 $\times$ ).

fore coxa mostly infused with brown/black. Forewing hyaline, veins and stigma light brown.

*Male*.—Similar to female in size, sculpture, and color, except that face below median ocellus clothed with dense golden pubescence. Clypeal free margin not serrate and only shallowly emarginate. Pedicel much narrower than first flagellomere; flagellum densely clothed with very short setae. Genitalia not studied.

*Etymology*.—The specific name refers to nests being found in old termite galleries.

*Diagnosis*.—The complete occipital carina, complete circumocular groove, rugose reticulate face, presence of the acetabular carina, strongly raised angulate pronotal carina, and serrated emarginate clypeus free margin distinguish this species. It is similar to *A. reticulatus* in the coarse sculpture of head and thorax, but in *A. reticulatus* the pedicel is nearly 2× as long as the first flagellomere, and the clypeal free margin is smooth. Males possess golden facial pubescence similar to that of *A. reticulatus* males.

*Arpactophilus hursti* Matthews and  
Naumann, sp. nov.  
(Figs 59–66; Table 1)

*Type material*.—Holotype ♀, Lake Gilles Conservation Park, South Australia, 29-v-1994, Pam Hurst, ex burrow in *Acacia papyrocarpa*, note C-11, in ANIC. Paratypes: 7 ♀♀, 2 ♂♂ all same locality as holotype (dates and notes are 29-v-1994, ex burrow in *Acacia papyrocarpa*, note C-11, 23-vi-1994, ex burrow in *Heterodendron*, 14-vii-1994 in Western Myall, #E-1); one ♀ 25.22S 151.07 E, Eidsvold, Qld., 11-x-1984, I. Naumann, J. Cardale, ex ethanol, all in ANIC.

*Female*.—Measurements and ratios as in Table 1. *Head*: Globular. Vertex and face irregularly rugose (Figs. 60, 61). Frons lateral to scapes clothed with short dense flattened silvery setae. Occipital carina (Fig. 61) strong laterally, nearly complete dorsally. Gena (Fig. 62) irregularly rugose, lacking a distinct genal carina. Antennal

scrobes narrow well-defined grooves, distinctly transversely striate to microreticulate. Frontal carina strongly raised above clypeus between scapes, lamellate, slightly thickened dorsally, and rounded in profile, extending onto about 1/2 length of clypeus. Circumocular groove (Figs. 61, 62) narrow, crenulate, continuous along outer, dorsal, and inner orbits. Clypeus roundly protuberant, apically emarginate (Fig. 63). Labrum with four teeth, outer ones barely evident, inner teeth much longer and somewhat pointed. Mandible evenly curved, bidentate apically, outer tooth about 2× as long as inner tooth, inner tooth relatively broad and blunt apically. *Antenna*: Scape and flagellomeres stout; first flagellomere subequal to pedicel and only slightly longer than wide. Scape length equal to pedicel plus first 4 flagellomeres. *Mesosoma*: Pronotal carina strongly raised, lamellate (Fig. 64), distinctly separated from anterior margin of mesoscutum with sharply angulate anterolateral margin; anterior face shining to transversely microreticulate. Mesoscutum (Fig. 64) convex, irregularly transversely rugulose over anterior third, becoming coarsely punctate on lateral portions, interspaces and central area predominantly microreticulate, finely rugose along posterior portion, lateral margins costulate; parapsidal lines and notauli distinct. Mesoscutellum microreticulate with sparse shallow punctures, prescutellar sulcus narrow with about 10 evenly spaced longitudinal carinae. Metanotum longitudinally strigose. Mesopleuron (Fig. 65) irregularly rugose, becoming obliquely strigose posteriorly, the interspaces microreticulate; hypersternaulus indistinct. Acetabular carina present. Metapleuron clothed with short hairs, obscuring microsculpture. Propodeal dorsum areolate rugose (Fig. 64), lateral face irregularly rugose grading to obliquely strigose, posterior face (Fig. 66) irregularly rugose, lacking tubercles on lateral margins. *Forewing*: Second submarginal cell narrowed anteriorly, nearly

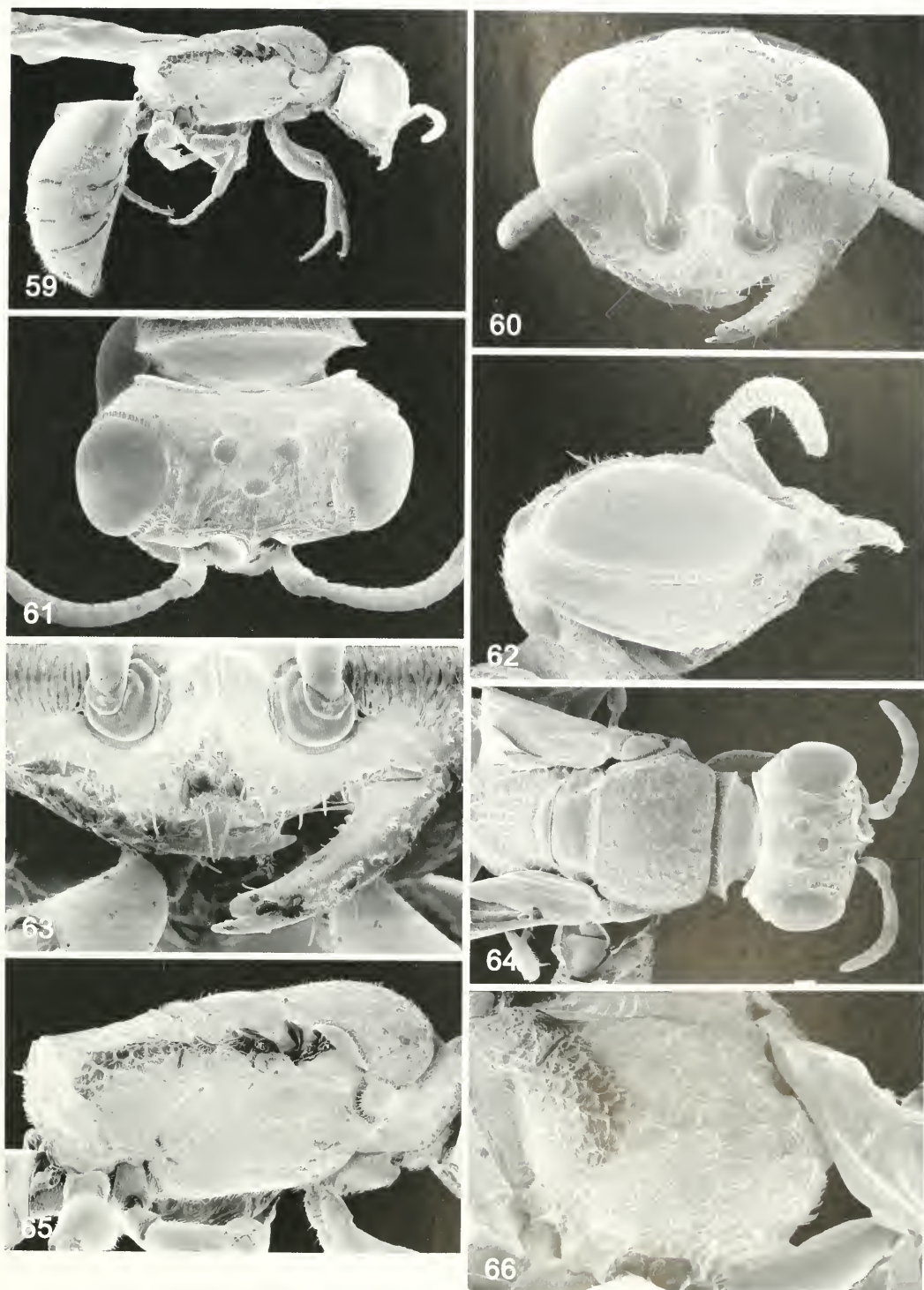

Figs. 59–66. *Arpactophilus hursti*, paratype female. 59, Body, lateral (20×). 60–62, Head, frontal (86×), dorsal (86×), and lateral (55×). 63, Lower face, clypeal margin and mandible (180×). 64, Mesosoma and head, dorsal (54×). 65, Mesosoma, lateral (43×). 66, Propodeum, posterior face (65×).

triangular; first recurrent vein received in submarginal I well proximal to bifurcation of Rs + M by a length distinctly greater than the anterior veinlet of submarginal II; M absent beyond 2r-m. *Metasoma*: Terga 1 and 2 smooth, shining, with widely scattered setigerous punctures. T2–5 uniformly faintly transversely microreticulate with scattered setae. T6 more densely setose, apically truncate with apical brush of short setae. *Color*: Head and mesosoma black, non-metallic, except clypeal margin red/orange. Metasoma, antenna, and legs (except coxae) orange/red. Mandible red/orange over basal third, distally amber brown. Fore coxa black, mid and hind coxa basally black, becoming increasingly suffused with red/orange distally. Forewing hyaline, venation and stigma light brown.

*Male*.—Identical to female in size, sculpture, and color, except frons (but not clypeus) completely covered with flat golden setae.

*Etymology*.—This species is named for its collector, Pam Hurst.

*Diagnosis*.—This species belongs to a group of relatively robust species apparently related to *A. bicolor*, and characterized by having metasoma red/orange and relatively rugose or coarsely punctate sculpture on mesonotum and head. The red/orange clypeal free margin, blade-like, strongly angulate pronotal carina, and absence of hypersternaulus readily separate this species from others in this group.

#### NOTES ON PREVIOUSLY DESCRIBED SPECIES

*Arpactophilus steindachneri* Kohl. — Kohl (1884) gives no explicit indication that he based his original description on more than one specimen, but he does give a range ("71/2–8 mm") for the body length. There are two females of *A. steindachneri* in the Naturhistorisches Museum, Wien which bear identical labels except that one bears the word "type" in Kohl's hand

writing. A rectangular, red label without data is also affixed to this specimen. Both females agree with Kohl's description and both are within the originally given range for body length. Thus, it seems likely that Kohl had both specimens before him. Accordingly, the specimen labeled "type" by Kohl is hereby designated as lectotype, and the second specimen, as paralectotype.

The type locality given by Kohl (1884) is "Australia". The provenance labels on the type specimens are equally imprecise. However, in the original description, Kohl gives Edward Damel (c. 1821–1900) as the collector. Damel made several collecting trips to Australia between 1852 and 1875, and some of his material was sold widely in Europe through Georg Thorey (1790–1884), a Hamburg insect dealer (Horn et al. 1990, p. 392). The latter explains the appearance of Thorey's name on the provenance labels of the *A. steindachneri* type material. Prior to 1864, Damel collected in Sydney (1852–1858), Western Australia (1859), and at Port Curtis, Queensland (1860) (Musgrave 1932, p. 60). *Arpactophilus steindachneri* has since been collected from several coastal or near coastal localities in north-eastern Australia, but is not known elsewhere. Presumably the type material of *A. steindachneri* was collected during Damel's Port Curtis sojourn which would place the type locality somewhere near present-day Gladstone.

*Arpactophilus bicolor* Smith.—In the original description of *A. bicolor*, Smith (1864) states, "The male differs in having the scape white in front." The female bearing the type label is thus a syntype.

#### BIOLOGY

Biological details for each of the nine newly described species plus *A. reticulatus* (Turner) follow. All nests were collected during the day, which means that some associated nest adults were probably absent at the time of collection. Voucher

nests for each species are deposited in the ANIC.

*Arpactophilus similus*.—Four nests of this flat-headed species were found, all in green, recently vacated galls of *Sphaleractis parasitica* Meyrick (Lepidoptera: Gelichiidae) on the geebung, *Persoonia falcata* (Proteaceae) at Kakadu NP, N.T. on 18–22 May 1999. Each nest contained a single female wasp. This, plus the nest architecture, suggests that this species is strictly solitary. In one nest, the two cells were in linear series in a tunnel whose diameter was 2 mm, and afforded no opportunity for movement between the wall and the cells. Cell one, 3.5 mm long, contained a prepupa, essentially naked with no evident cell lining. The cell partition was a tan “leathery” parchment-like material, and difficult to tear. The second cell (also 3.5 mm long) contained a mature larva, but no prey. The partition was a flimsy silken curtain. We suspect that the leathery appearance of the partition derived from fluids added to the silken curtain by the mature larva when it transformed to the prepupa.

A second nest was recently initiated, and contained a single egg suspended in a mesh of silken threads 2 mm from the base of a 22 mm long burrow; there was a flimsy silk curtain 2 mm further beyond it. The only other silk was a 1 mm meshwork of threads just inside the nest entrance.

A third nest contained a teneral female, newly emerged from a single cell occupying the burrow 4–7 mm inside the entrance. Behind the cell the empty and unlined burrow extended another 20 mm. The outer partition to this cell was parchment-like, opaque brown and taut. The inner partition was a semitransparent matrix consisting of crisscrossed silken threads.

The fourth nest contained a single female wasp, but had no trace of any silk or brood, evidently having been only recently occupied.

*Arpactophilus platycephalus*.—Two nests of this flat-headed species were found on Magnetic Island, Qld. on 8 Nov. 1998. Both were in recently vacated green galls made by *Sphaleractis* sp. on *Persoonia falcata*. The first nest burrow was 23 mm long, with the basal 3 mm empty. It contained three cells in a linear series, with a single female resting in the burrow. The basal cell was 4.5 mm long and contained a new pink-eyed pupa in a delicate tan papery cocoon 3.5 mm long. Cell 2, also 4.5 mm long, contained a prepupa in a similar delicate cocoon. Cell 3 contained a small larva suspended in a few silken strands feeding on unrecognizable prey remains, with a single intact psyllid nymph also suspended in silken strands next to it. No silk was evident along the outer part of the burrow. The pupa of cell 1 desiccated, but the prepupa of cell 2 produced a female on 27 November.

The second nest collected at the same site held a female resting in front of a silk partition that completed the single cell at the base of the 30 mm long burrow. The cell was 4.5 mm long, and began 1.7 mm from the bottom, and contained a full-grown predefecating larva that was spinning its cocoon. It pupated 8 days later, and a female emerged after a further 11 days. The remainder of the nest burrow was empty, with no evidence of silk lining.

Both *A. platycephalus* and *A. similus* appear to be strictly solitary species that invade newly available galls of *Sphaleractis* on *Persoonia falcata*. They are relatively rare, compared to congeneric species nesting in the same galls at the same sites. For example, of 124 galls collected from a single tree of *P. falcata* at Kakadu NP, only 2 contained *A. similus* nests, while 20 contained nests of *A. kakaduensis* (see below).

*Arpactophilus transversus*.—Two species, *A. transversus* and *A. termes*, nest in abandoned termite galleries, both taken in Kakadu NP, NT. *Arpactophilus transversus* lines old termite galleries on rock surfaces with

silk. Because of the fragile nature of the nest material, nest details are unknown, but it may be a solitary species. Naumann (1983) recorded *A. transversus* as *Arpactophilus* sp. 48. In June 1984 we collected two additional females from termite galleries at the same locality. Two of three prey removed from their nests were psyllid nymphs of the lerp forming type, probably taken from *Eucalyptus* (det. K. L. Taylor, *in litt.*). The other prey was a cicadellid nymph tentatively identified as belonging to the subfamily Ulopiinae (det. T. E. Woodward, *in litt.*). This is the only *Arpactophilus* species for which Cicadellidae are known as prey. Curiously, in May 1999, extensive searching of termite galleries on the same rock faces collected from in 1984 failed to turn up any nests of this species.

*Arpactophilus termes*.—This species is known from a single large nest collected at Kakadu NP, NT, that contained 14 females and five males. This nest was in a depression on a nearly vertical rock face about 1.5 m above the ground. The nest surface measured roughly 20 by 60 mm, but was irregular in shape and variable in depth to a maximum of about 10 mm and was inside and completely covered by termite gallery. There appeared to be two entrances about 40 mm apart. Less than 1 cm from one edge of the gallery was a mud cell of *Sceliphron formosum* (F. Smith) that contained a nest of *A. mimi* with three females.

The termite gallery material was so fragile that it disintegrated during collection. Apparently there were several interconnected passageways that led to different parts of the nest, but definite structure could not be determined. In all, 33 silken cells were recovered, of which 14 contained progeny in various stages of development—five pupae, three prepupae, and six larvae of various sizes. Other cells were empty, and no eggs or prey were recovered. However, part of the nest con-

tents were spilled in the field, with an estimated 10–12 cells lost.

Cells were found in clusters of one to five, tightly stuck to each other and to the nest material with silk. Extensive areas inside the termite gallery were lined with white silk and in some areas there were numerous white specks, presumed to be adult defecation. Mature larvae were enclosed in light tan silk cocoons, quite strong, although they could be readily torn with forceps.

If we assume that this was a single nest, then *A. termes* has by far the largest nests of any known species. In part this may reflect the fact that termite gallery is often extensive, potentially offering significantly more space for nesting than does a beetle burrow, mud wasp cell, or lepidopteran gall, all of which are of limited size.

*Arpactophilus deakinus*.—Three nests of this species were collected 24 January to 6 February, 1999 in the Canberra suburb of Deakin, ACT. Two nests were in stems of an ornamental azalea hedge planting, and the other in a pithy stem of *Hydrangea*. Both azalea and *Hydrangea* are exotic plants to Australia. The stems were 6–8 mm in diameter. All of the burrows were relatively short (27 mm, 23 mm, and 22 mm), 2.5–3.5 mm in diameter, and all were heavily lined with white silk. The two nests in azalea were in stems that had been previously used by other nesting hymenopterans; one was unidentifiable, but the other basal nest was that of *Nitela australiensis* Schulz (Matthews 2000b). This nest had three *A. deakinus* females present, and contained two cells, the basal one with a mature larva, and the second with a new egg (Fig. 67).

The other azalea nest contained four cells and three adult females. The basal cell contained a pupa with pink eyes, the second cell contained a new white pupa, the third cell a nearly mature larva with a partly consumed unidentified prey, and the fourth cell contained an egg. Cell lengths were 5–8 mm. Partitions were of

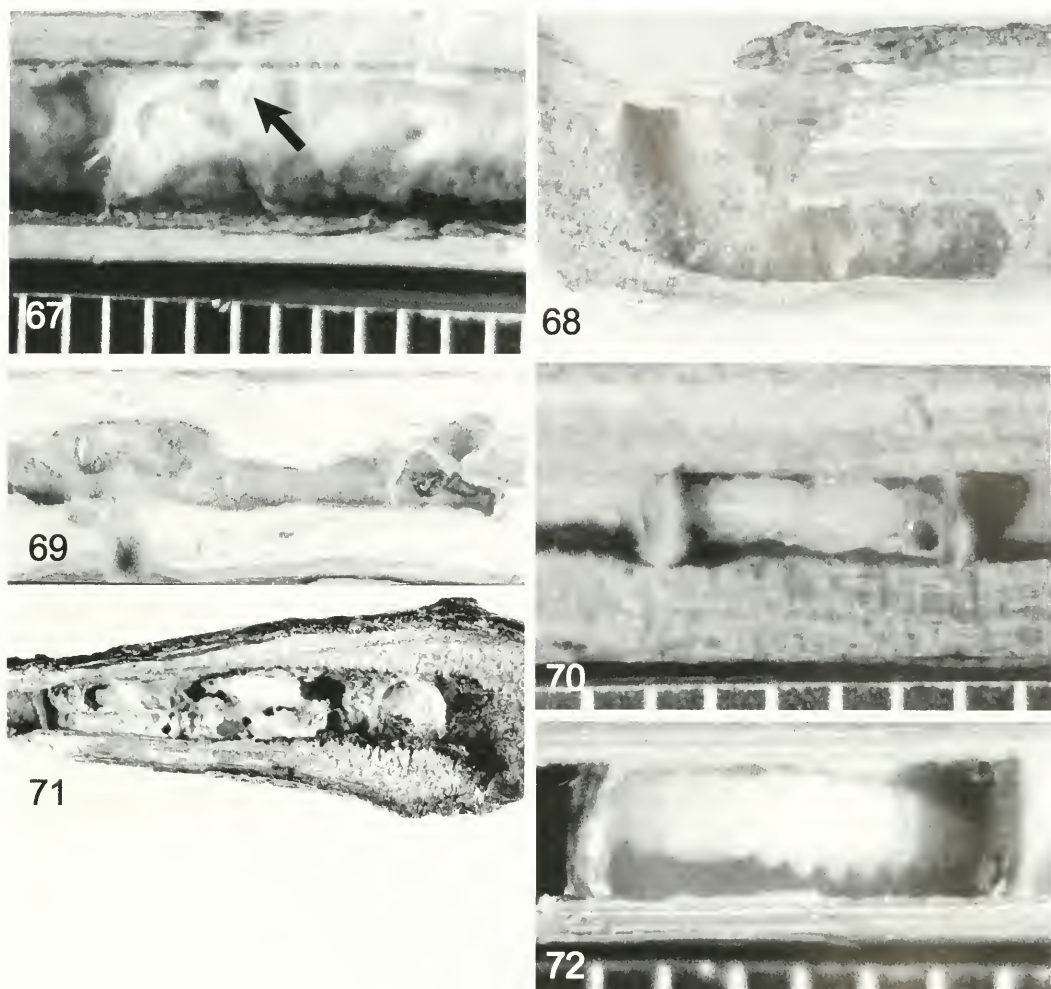

Figs. 67–72. Nests of *Arpactophilus* species. 67, Cell of *A. deakinus* in azalea stem containing an egg suspended in extensive silk matrix, part of which is laid back to better expose the egg. Egg measures  $1.4 \times 0.4$  mm. Scale units are mm. 68, A beetle tunnel in a dead branch of *Acacia papyrocarpa* used as a nest by *Arpactophilus hursti*. One female emerged from cell in base closed by a leathery silk partition. 69, New nest of *A. magneticus* in beetle burrow in a small branch of *Mallotus philippensis* (red kamulla) containing a single cell at end of lower right fork. The only silk was at the end of the burrow and a “curtain” across the burrow at the fork. Nest entrance at lower left. Burrow length 11 mm from entrance to end of lower right cell, and burrow diameter about 1 mm. 70, A naked pupa of *A. flavifrons* in a hollow 5 mm diameter stem of *Lophostemon grandiflorus*. Scale units are mm. 71, Nest of *A. kakaduensis* containing six cells in an old gall of *Sphaleractis parasitica* on *Persoonia falcata*. Note the silk enclosed pupal cells at the left (one partially torn open) and the extensive silk lining in the middle portion of nest burrow which measured  $22 \times 3$  mm. Entrance at lower right. 72, A prepupa of *A. reticulatus* in bamboo. Scale units are mm.

flimsy silk, probably constructed or at least reinforced by the mature larva, and pupae were naked. The white sausage-shaped egg was suspended transversely across the burrow in a silk mesh (Fig. 67).

The pupa in cell one was damaged when the nest was split open, but the progeny in cells two and three later emerged as adult females. The pupal stage took 21 days.

The third nest (in *Hydrangea*) contained two females, but no brood, and it appeared that one or both of the females was recently emerged from the nest. Thus there are at least two and perhaps three generations per year in Canberra. Because each of the three nests found contained more than one female, *A. deakinus* appears to be a cooperative nester, although its precise social status is unclear.

*Arpactophilus hursti*.—Figure 68 shows the empty nest of *A. hursti* in a short, old beetle burrow found in a small, dead branch of *Acacia papyrocarpa*. Three nests in similar branches were collected by Pam Hurst from the Lake Gilles Conservation Park in South Australia in May–June 1994, and another was found in a old beetle burrow in *Heterodendron* sp. The longest of these had a burrow 115 mm long and 4 mm diameter. No notes were made at the time of collection, the nests only being opened after the wasps were found emerged, and so no interior structure was identifiable.

*Arpactophilus magneticus*.—Seven nests of this diminutive species were discovered on Magnetic Island, Qld. between 16 September 1998 and 6 December 1998. All were in old convoluted beetle burrows in slender (7–10 mm in diameter) recently dead branches of various trees. Current beetle activity was noted adjacent to some nests, which suggests that none of the nests was more than a few weeks old. The trees were red kamulla *Mallotus phillipensis* (Lam.) Muell. Ang (Euphorbiaceae), northern swamp mahogany *Lophostemon grandiflorus* (Benth.) (Myrtaceae), and *Neolitsea australiensis* Kostermans (Lauraceae). The number of cells per nest ranged from one to five; however, both of the nests found in December contained single cells with small larvae (Fig. 69), and their burrows lacked silk lining, suggesting that they were recently initiated, probably by solitary females.

One nest in *Lophostemon* contained two females and one male. Two nests in adja-

cent beetle burrows in another small branch of *Lophostemon* contained six adults, four females and one male (one adult escaped). Two nests in beetle burrows about 5 cm apart on a single branch of *Mallotus* contained one and two females respectively. Another nest in *Mallotus* contained a single female. The nest in *Neolitsea* contained a single male.

The beetle burrows varied from 1 to 3 mm in diameter, and some presented an oval cross section, which permitted resident adults to move freely alongside occupied cells. Unused parts of the beetle burrows were packed with frass. In some the wasps walled off distal sections of the frass-filled burrows, lining the cleaned portions with silk. Also, in some, the beetle tunnels extended in opposite directions from their exit hole (the nest entrance), and in these instances the wasps used both tunnel branches, arranging the cells in linear fashion. Immature stages in a given nest were all at distinctly different stages of development and there was never more than one egg in a nest. The cylindrical, white egg measured  $0.85 \times 0.4$  mm and was suspended in silk mesh, occupying about 1 mm of burrow with a flimsy silk "curtain" at the outer end. Completed cells were 4–7 mm long and separated with silk partitions. Pupae were in flimsy, translucent, silken cocoons, which were easily torn. Only one prey was recovered, an unidentified, immature psyllid found next to a small larva.

Older nest burrows (those with 3–5 cells) were extensively lined with silk. In one instance it was discovered that the silk was quite elastic. Several strands were grasped with forceps and stretched to more than twice their original length; when released they recoiled into wavy strands about half as long.

Males of this species are distinctive in possessing dense, silvery pubescence over the lower two-thirds of the face. This pubescence is postulated to be related to sex recognition and courtship.

*Arpactophilus flavifrons*.—One nest was found in an old beetle burrow in a slender twig (5 mm in diameter) of the northern swamp mahogany, *Lophostemon grandiflorus* (Myrtaceae) on Magnetic Island, Qld. on 28 October 1998. The 1.5–2 mm diameter burrow extended in both directions from the single entrance, 28 mm to the left side, and 49 mm to the opposite. One cell 3 mm long and containing a late pupa was at the base of the shorter left branch; this pupa dried out. The longer branch of the burrow contained three cells, ranging from 4.5–13.5 mm long. There was empty tunnel for 21 mm from the distal partition of the outermost cell to the nest entrance. The three cells contained a newly eclosed female, an adult male, and a naked pupa (Fig. 70) that emerged as an adult female 11 days later. The entire unused sections of burrow on both sides of the entrance were silk lined. Additional evidence that this nest was relatively old was that beyond the active three cells was an old moldy *Arpactophilus* thorax, sealed behind a silk partition.

A second incipient nest was found in a slender node of bamboo on Magnetic Island on 14 December 1998. The nest burrow was 57 mm long and 1.5 mm in diameter. There was a single empty cell 5.5 mm long at the bottom of the burrow, and one female wasp was resting in the burrow.

*Arpactophilus kakaduensis*.—Found only in Kakadu NP, NT, and predominantly nesting in empty woody galls of *Sphaleractis parasitica* on *Persoonia falcata* (Proteaceae), this wasp was relatively common. From one tree 20 nests were obtained from a sample of 124 old (prior year) woody galls. Most of the other galls were unoccupied, so that lack of potential nest sites did not appear to limit populations. Two nests were found in smaller, unidentified galls (9–12 mm long and 2–3 mm in diameter) on an unidentified tree.

Twenty-four nests collected 20–24 May 1999 contained up to 5 adult females and

up to 10 cells (average of 3.4 cells/nest). Burrows of nests in *P. falcata* galls were from 12–30 mm long and 2–4 mm in diameter. Pupae were enclosed in flexible, soft, white, silken cocoons, easily torn with forceps (Fig. 71). Cells were usually clustered in the basal section of the gall. Most of the nest interiors were extensively silk-lined, especially in older nests with more than two cells, and cells were separated with silk partitions. Summarized brood contents of 69 occupied cells consisted of 6 eggs, 20 larvae, 11 prepupae, and 32 pupae. In the largest nest containing 10 cells and 5 females, two eggs were present, suggesting that two or more females may have been ovipositing.

In the plastic bag used to transport the *Persoonia* galls to the laboratory, two male *Megalyra* sp. (Megalyridae) were discovered. Because another species of *Megalyra*, *M. troglodytes* Naumann, is recorded as a parasite of *A. mimi* from the same locality (Matthews and Naumann 1988), we suspect that this apparently undescribed species may attack *A. kakaduensis*. However, no direct evidence of parasitism was found in the nests sampled, but these two individuals must have been inside one or two galls when the sample was collected. The specimens are deposited in the ANIC.

*Arpactophilus reticulatus*.—This species is widely distributed across northern Australia from the Kimberley Region, W.A. to Kuranda, Qld. in the east. Based on our observations, *A. reticulatus* is the most catholic of any of the known species in its choice of nest sites. We found 14 nests in pre-existing cavities in five species of plants and in diverse habitats from bushland to urban yards.

Thirteen nests were collected on Magnetic Island, Qld., and one on the campus of James Cook University, Townsville, Qld. between 17 September and 6 December 1998. Six nests were found in internodal sections of bamboo (Fig. 72). Four of these were constructed in the outer portion, with debris from prior hymenopter-

an nests walled off in the basal portions. Four nests were found in woody galls of *Sphaleractis* sp. on *Persoonia falcata* (Proteaceae). The other nests were in old beetle burrows in slender dead branches on three trees: northern swamp mahogany, *Lophostemon grandiflorus* (Myrtaceae) (one nest); the native mulberry, *Pipterus argenteus* (G. Gorster) Wedd. (Urticaceae) (2 nests); and the Brazilian pepper tree, *Schinus terebinthifolius* Raddi (Anacardiaceae) (one nest). The latter was found on the JCU campus.

Nest tunnels were 1.5–3.0 mm in diameter, and varied in length from 13–97 mm. The amount of silk lining of the burrows varied from extensive in *Persoonia* galls to little in bamboo stems. Eight nests contained no adults when collected, five contained single females, and one contained two females. Curiously, this latter nest was only recently initiated, containing a single cell with an egg (1.4 × 0.5 mm) suspended in silk mesh. With this possible exception, it appears that *A. reticulatus* is essentially a solitary wasp.

Number of cells ranged from 1–5/nest (average 2.5). Cell lengths varied widely, but cells with pupae or prepupae were 4.5–6.5 mm long with the pupae in flimsy cocoons. Silk spun by larvae was distinctly tan colored. Three of the six larvae had fresh psyllid nymphs (unidentified) suspended in silk adjacent to them, two being provided with two prey and the other with three prey. Several progeny were successfully reared, yielding four males and seven females.

Two nests of this species, one on Magnetic Island in a *Persoonia* gall and the other from the JCU campus in a *Schinus* branch, were parasitized by *Calosota* sp. (Eupelmidae). In each nest all three cells were parasitized, yielding five females and one male parasite. This chalcidoid attacks the larval or pupal stages of its host. *Calosota* is a cosmopolitan genus recorded from various stem-nesting bees and wasps (Noyes 1998). In Australia it has also been

reared from *Psenulus interstitialis* Cameron on Magnetic Island (Matthews 2000a).

## DISCUSSION

All known species of *Arpactophilus* appear to be progressive provisioners. All apparently suspend their relatively large eggs in a silken meshwork. So far as known, all prey on nymphs of psyllids (rarely tingids or cicadellids) which are placed individually enmeshed in silk adjacent to the feeding larva. All known species appear to have more than one generation per year. All appropriate various types of pre-existing cavities, ranging from old termite galleries to abandoned beetle burrows and lepidopteran galls or hollow stems in a variety of plants. Four species (discussed below) nested in abandoned lepidopteran galls in geebung, *Persoonia falcata* (Proteaceae), a widely distributed tree common across northeastern Australia. Previously, *A. mimi* Naumann was recorded from old mud wasp nests (Matthews and Naumann 1988). Interestingly, none of the species described herein were found to have entrance guards as in *A. mimi*. Nor did any of the species have a discernible odor like the lemony odor noted from the heads of *A. mimi* (Matthews and Naumann 1988).

Although at least two of the known Australian species, *A. mimi* (see Matthews and Naumann 1988) and *A. termes*, appear to be socially advanced, at the other end of the spectrum, at least four seem to be strictly solitary: *A. platycephalus*, *A. similis*, *A. flavifrons*, and *A. reticulatus*. With the presence of numerous adults in a nest, *A. termes* is possibly the social equivalent of some eusocial *Microstigmus*, but more study is required since only one nest of *A. termes* was found. In the case of *A. mimi*, other solitary wasps (including conspecifics) and bees competing to reuse the old mud cells of *Sceliphron formosum* were postulated as an important selective pressure favoring nest guarding as empty mud cells were essentially non-existent at Kakadu (Naumann

1983; Matthews and Naumann 1988). In contrast, empty lepidopteran galls on *Persoonia falcata* at Kakadu were relatively common. In one sample from a single tree, 93 of 124 old dead galls (75%) were unoccupied; in another sample from six trees 29 of 68 old galls (43%) were empty. This suggests that interspecific competition from competing "renting" species may not be as strong in the relatively unsaturated gall habitat. Also, the availability of potential nest sites may relax the pressure from conspecifics, postulated as an important force driving sociality in *A. mimi* (Matthews and Naumann 1988). Thus, the discovery of apparently solitary *Arpactophilus* species is perhaps not surprising.

In the arboreal setting of most species discussed here, foraging ants are ubiquitous and ant predation would seem to constitute a major threat to *Arpactophilus* nests. However, no instances of ant predation were observed. Possibly the silk used to line the burrow and suspend the eggs and prey items in the nest contains chemicals that are either neutral or repellent to foraging ants. Various species of ants were commonly encountered in the lepidopteran galls on *Persoonia falcata*, even adjacent to galls occupied by *Arpactophilus*. Thus, ants may compete for potential nest sites, although where these galls were relatively numerous, as was true at Kakadu National Park, empty unused galls were common.

The incidence of parasitism was also extremely low. Only one species of parasite was reared from any of the *Arpactophilus* species discussed here. *Calosota* sp. is a generalist species known to attack various stem nesting wasps and bees. It was reared from two of 14 nests of *A. reticulatus*, a solitary species. Presumably the parasite oviposited while the female was away, since all the larvae or pupae in each nest were parasitized. Previously, the only parasite recorded from any *Arpactophilus* was *Megalynra troglodytes* Naumann (Megalynridae) which attacked *A. mimi* (Mat-

thews and Naumann 1988), but the incidence of parasitism was extremely low (5 of 109 cells parasitized, 4.6%). Such low levels of parasitism are consistent with the trend in other members of the Spilomenina (discussed in Matthews 1991), but contrast strikingly with those found in other sphecids, such as *Sceliphron* which typically experiences 20–40% parasitism or more (Naumann 1983, Smith 1979), suggesting that the increased level of parental care observed in *Arpactophilus* is a highly successful strategy.

Presumably parental care extends until all the brood have emerged, as no outer nest entrance closures were found, and in several instances active nests contained only late pupae, with no younger brood stages present. In most species for which nests are known, brood development suggests that only a single adult is reproductive because every immature individual present was at a distinctly different stage of development. (The only exception was an unusually large 10-celled nest of *A. kakaduensis* that contained 5 adult females and had 2 eggs.)

Nothing has been recorded on the biology of the larger *Arpactophilus* species (*A. arator*, *A. bicolor*, *A. deserticolus*, *A. kohlii*, *A. steindachneri*, and *A. sulcatus*), other than a description of the larva of *A. steindachneri* by Evans (1964). Evans gives as his source for this material specimens collected by C. D. Michener at Yaamba, Queensland in August 1958. Michener (*in litt.*) says his field notes for the date of the specimens are uninformative as to details of nests or habitat. However, one individual of *A. steindachneri* in the Queensland Museum, collected by H. Hacker from Brisbane, Queensland, 6/7/15, bears a handwritten label "adult dug out of sand bank". This report of apparent soil nesting needs confirmation; in particular it needs to be determined whether nests are dug *de novo* or made in preexisting tunnels. If indeed some species nest in soil, then *Arpactophilus* would display one of the broadest

nesting niches of any sphecid, but still not unique. Another member of the Spilomenina clade, *Spilomena*, has at least one species that excavates nests in the soil (McCorquodale and Naumann 1988), although other known members of *Spilomena* nest in preexisting cavities.

In both *Spilomena* and *Arpactophilus* the most striking biological attribute is their use of silk in nesting. The use of silk as a sort of "glue" has meant that potentially any substrate can be remodeled and sculpted to serve as a nest. In the other large genus of Spilomenina, the Neotropical *Microstigmus*, various species use silk to fashion nests of plant hairs, rock bits, or wood chips (Matthews 1991). The postulated energetic expense of silk production has been suggested to be the basis for the unique social evolution in this clade (Matthews 1991).

#### ACKNOWLEDGEMENTS

We gratefully acknowledge the loan of the type specimens of *Arpactophilus* to IDN from Naturhistorische Museum, Vienna (Dr. M. Fischer) in July 1985, and from the Natural History Museum, London (Dr. M. Day). Thanks also to curators of the following Australian collections for loan of their material: Queensland Museum (Drs. E. C. Dahms and C. Burwell), University of Queensland Insect Collection (Dr. M. Schneider), the Australian Museum (Mr. M. Moulds), Museum of Victoria (Dr. K. Walker), South Australian Museum (Dr. E. Matthews), and Western Australian Museum (Dr. T. Houston). We thank Dr. Gary A. Gibson (Canadian National Collection, Ottawa) for identifying the chalcid parasite and Mr. Ted Edwards (Australian National Insect Collection) for identifying the gall making gelechiid moth. Ms. Jo C. Cardale (Australian National Insect Collection), Dr. Michael Ohl (Museum für Naturkunde der Humboldt-Universität Berlin), and Dr. Michael Prentice carefully reviewed the manuscript and made many valuable suggestions. Dr. Betsy Jackes (James Cook University, Townsville) provided invaluable assistance with the identification of various plants on Magnetic Island. Mr. Eric Hines (CSIRO) gave much assistance with the SEMs. The Queensland Department of the Environment kindly granted a Scientific Purposes Collecting Permit for Magnetic Island National Park, and Parks Australia North provided a permit to work on *Arpactophilus* in Kakadu National Park. The Department of Zoology and Marine Ecology, James Cook University and the Department of

Entomology, University of Georgia provided logistical and financial support to RWM. A McMaster Fellowship from CSIRO, Canberra to RWM is gratefully acknowledged.

#### LITERATURE CITED

- Bohart, R. M. 1999. New species of *Arpactophilus* from the island of New Caledonia (Hymenoptera, Sphecidae). *Insecta Mundi* 13: 97–110.
- Bohart, R. M. and A. S. Menke. 1976. *Sphecidae Wasps of the World. A Generic Revision*. University of California Press, Berkeley.
- Dollfus, H. 1983. The taxonomic value of male genitalia of *Spilomena* Shuckard, 1838, from the palearctic region (excl. Japan) (Hymenoptera: Sphecidae). *Entomofauna, Zeitschrift fuer Entomologie* 4 (22): 349–370.
- Eady, R. D. 1968. Some illustrations of microsculpture in the Hymenoptera. *Proceedings of the Royal Entomological Society of London (A)* 43: 66–72.
- Evans, H. E. 1964. Further studies on the larvae of digger wasps (Hymenoptera: Sphecidae). *Transactions of the American Entomological Society* 90: 235–299.
- Harris, R. A. 1979. A glossary of surface sculpturing. *Occasional Papers in Entomology* 28: 1–31.
- Horn, W., I. Kahle, G. Friese, and R. Gaedike. 1990. *Collectiones Entomologicae*. Akademie der Landwirtschaftswissenschaften der Deutschen Demokratischen Republik, Berlin. 573 pp.
- Kohl, F. F. 1883 (1884). Neue Hymenopteren in den Sammlungen des k.k. zoologischen Hof-Cabinetes zu Wien. ii. *Verhandlungen der kaiserlich-koeniglichen Zoologisch-Botanischen Gesellschaft in Wien* 33: 331–386.
- Matthews, R. W. 1991. The evolution of social behavior in sphecid wasps. In: *The Social Biology of Wasps*. R. G. Ross and R. W. Matthews, eds. pp. 570–602. Cornell University Press, Ithaca, NY.
- Matthews, R. W. 2000a. Nesting biology of the stem-nesting wasp *Psenulus interstitialis* Cameron (Hymenoptera: Crabronidae: Pemphredoninae) on Magnetic Island, Queensland. *Australian Journal of Entomology* 39: 25–28.
- Matthews, R. W. 2000b. A new species of *Nitela* (Hymenoptera: Sphecidae: Larrinae) from Australia with notes on the nests and prey of two species. *Journal of Hymenoptera Research* 9: 41–47.
- Matthews, R. W. and I. D. Naumann. 1988 (1989). Nesting biology and taxonomy of *Arpactophilus mimi*, a new species of social sphecid (Hymenoptera: Sphecidae) from northern Australia. *Australian Journal of Zoology* 36: 585–597.
- McCorquodale, D. B. and I.D. Naumann. 1988. A new Australian species of communal ground nesting wasp, in the genus *Spilomena* (Hymenoptera: Sphecidae: Pemphredoninae). *Journal of the Australian Entomological Society* 27: 221–231.

- Melo, G. A. R. 1999. Phylogenetic relationships and classification of the major lineages of Apoidea (Hymenoptera), with emphasis on crabronid wasps. *Scientific Papers. Natural History Museum. The University of Kansas* 14: 1–55.
- Menke, A. S. 1989. *Arpactophilus* reassessed, with three bizarre new species from New Guinea (Hymenoptera: Sphecidae: Pemphredoninae). *Invertebrate Taxonomy* 2: 737–747.
- Menke, A. S. 1997. Family-group names in Sphecidae. *Journal of Hymenoptera Research* 6: 243–255.
- Musgrave, A. 1932. *Bibliography of Australian Entomology, 1775–1930, with Biographical Note on Authors and Collectors*. Royal Zoological Society of New South Wales, Sydney.
- Naumann, I. D. 1983. The biology of mud nesting Hymenoptera (and their associates) and Isoptera in rock shelters of the Kakadu Region, Northern Territory. In: *The Rock Art Sites of Kakadu National Park—Some Preliminary Research Findings for the Conservation and Management*. D. Gillespie, ed., pp. 127–189, Australian National Parks and Wildlife Service, Special Publication No. 10.
- Noyes, J. S. 1998. *Catalogue of the Chalcidoidea of the World*. CD-ROM. Expert Centre for Taxonomic Information, Amsterdam.
- Smith, A. 1979. Life strategy and mortality factors of *Sceliphron laetum* (Smith) (Hymenoptera: Sphecidae) in Australia. *Australian Journal of Ecology* 4: 181–186.
- Smith, F. 1864. Catalogue of hymenopterous insects collected by Mr. A. R. Wallace in the Islands of Mysol, Ceram, Waigiou, Bouru and Timor. *Journal of the Linnean Society of London Zoology* 7: 6–48.
- Turner, R. E. 1908. Notes on the Australian fossorial wasps of the family Sphegidae, with descriptions of new species. *Proceedings of the Zoological Society of London* 1908: 457–535.
- Turner, R. E. 1912. Notes on fossorial Hymenoptera. IX. On some new species from the Australian and Austro-Malayan regions. *Annals and Magazine of Natural History* (8) 10: 48–63.
- Turner, R. E. 1916. Notes on fossorial Hymenoptera. XIX. On new species from Australia. *Annals and Magazine of Natural History* (8) 17: 116–136.
- Turner, R. E. 1936. Notes on fossorial Hymenoptera. XLV. On new sphegid wasps from Australia. *Annals and Magazine of Natural History* (10) 18: 533–545.

## Review of the Australian Subfamily Pteryperginae (Hymenoptera: Symphyta: Pergidae)

STEFAN SCHMIDT, DAVID R. SMITH, AND JOHN MACDONALD

(SS) Australian National Insect Collection, CSIRO Entomology, GPO Box 1700, Canberra, ACT 2601, Australia [current address: State Museum of Natural History Stuttgart, 70191 Stuttgart, Germany], e-mail: s.schm@gmx.net; (DRS) Systematic Entomology Laboratory, PSI, Agricultural Research Service, U.S. Department of Agriculture, c/o National Museum of Natural History, Smithsonian Institution, Washington, DC, 20560-0168, USA, e-mail: dsmith@sel.barc.usda.gov; (JM) University of Sydney, Orange, PO Box 883, Orange, NSW 2800, Australia, e-mail: jmacdona@oac.usyd.edu.au

---

*Abstract.*—Pteryperginae are endemic to Australia where one genus and three species are known, *Pteryperga galla* Benson, *P. bifasciata* (Brullé), and *P. hyaloptera* Schmidt and Smith, n. sp. A key to species is provided, and each is described and illustrated. The male of *P. galla* is described for the first time. Larvae of *P. galla* (on *Elaeocarpus reticulatus* Smith, Elaeocarpaceae) and *P. hyaloptera* (host unknown) are illustrated.

---

The subfamily Pteryperginae was proposed by Benson (1938a, b) for two species from Australia, *Pteryperga galla* Benson 1938a and *P. bifasciata* (Brullé 1846). Specimens are scarce in collections, and little has been published on the subfamily since its recognition.

Prompting this review was the discovery of an unusual adult pterypergine collected in a temperate rainforest area in southeastern Queensland by the senior author. About a month after this adult was collected, and, at the same locality, the same author found a larva resting on a fern near the ground. The larva apparently was full grown and went into the ground for pupation the next day. The adult that later emerged was the same pterypergine species that was hand collected previously in the same area. These two specimens represent a new species of Pteryperginae and are very dissimilar from the two previously described species of *Pteryperga*. However, they conform to the generic definition of *Pteryperga*, and we prefer to place them as a third species of the genus.

We also have examined additional spec-

imens of *P. galla* and here describe the male for the first time, and we present illustrations of the larvae of *P. galla* and *P. hyaloptera*, n. sp. We did not find additional specimens of *P. bifasciata*, which remains unknown since its original description in 1846.

### METHODS

The photomicrographs were obtained using a digital camera (ProgRes 3012, Jenoptic Laser, Systeme GmbH) and processed using the AutoMontage system, version 2.04 (Synoptics Ltd.) and a Sony Digital Photo Camera DKC-5000. The digital images were enhanced and the plates prepared using Adobe PhotoShop<sup>TM</sup>.

Acronyms used are as follows: Australian National Insect Collection, Canberra, Australia (ANIC); The Natural History Museum, London, U.K. (BMNH); Agriculture Scientific Collection Unit, Orange, Australia (ASCU); South Australian Museum, Adelaide, Australia (SAMA); National Museum of Natural History, Smithsonian Institution, Washington, DC, USA (USNM).

PTERYPERGINAE

The subfamily is characterized in the keys to subfamilies of Pergidae by Benson (1938b), Riek (1970), and Naumann (1991) as follows: Forewing without an anal cell (A), crossvein 2r-m absent, thus 2nd and 3rd radial cells (Rs and 1Rs2) joined, radial cell (R1) closed with apical accessory vein, costa swollen apically but basally much narrower than intercostal area; costal cell proximally with intercostal crossvein (Sc1); hind wing with radial cell (R1) open; pronotum without accessory furrow; mesoscutellum rounded behind, not lobed or produced posterolaterally and not carinate; cenchri large, nearly meeting at center; foretibia with two subequal apical spurs; mid- and hind tibiae each with preapical spine; propodeum sclerotized; labium 3-lobed; maxillary palpus 6-segmented, labial palpus 4-segmented; propleura medioventrally narrowly rounded or acute, far apart and not meeting medially.

Pteryperginae share characteristics with both the Perginae and Pterygophorinae. With the Pterygophorinae, they share the similar reduced wing venation by lacking 2r-m and having a narrow costa basally in the forewing and cell R1 of the hind wing open apically; the medioventrally widely separated propleura; lack of posterior projections on the mesoscutellum; sclerotized first tergum of the abdomen; serrate antennae of the female; and pectinate antennae of the male. Pterygophorinae differ, however, by the absence of preapical spines on the mid- and hind tibiae; presence of an accessory furrow on the dorsal angle of the pronotum; smaller cenchri which are far apart; and the unipectinate antennae of the male (bipectinate in Pteryperginae).

With Perginae, Pteryperginae share the

presence of preapical spines on the mid- and hind tibiae; sclerotized first tergum; and the large cenchri, almost meeting at the center. Perginae are separated by the presence of 2r-m and swollen costal cell of the forewing; closed R1 of the hind wing; short, non-serrate antennae of both sexes with fewer than 9 segments; presence of an accessory furrow on the pronotum; propleura almost truncate medioventrally and meeting medially; and the mesoscutellum with posteriorly projecting lobes.

We believe the shared character states of the reduced wing venation, lack of posteriorly projecting lobes of the mesoscutellum, and similarly shaped antennae place Pteryperginae closest to Pterygophorinae. Preliminary results of a phylogenetic analysis of world Pergidae currently under way by SS and DRS support this hypothesis.

*Pteryperga* Benson

*Pteryperga* Benson 1938a: 623.—Smith 1978:148 (catalog).

Type species: *Pteryperga galla* Benson, by original designation.

*Description.*—Head in front view broader than long; labrum flat, slightly emarginate apically, about 2× longer than clypeus; clypeus small, its breadth less than half distance between eyes, its length equal to length of pedicel; eyes slightly converging below, far apart, lower interocular distance about 1.3× eye length; distance of antennae behind clypeus equal length of pedicel; malar space equal breadth of pedicel; antenna 12–20 segmented, central segments serrate in female, flagellar segments bipectinate in male with rami dorsoventrally flattened, clavate, and ramus of 3rd segment much larger and broader than rami of remaining segments.

KEY TO SPECIES OF *PTERYPERGA*

- 1. Female; flagellar segments simple ..... 2
- Male; flatellar segments bipectinate ..... 4

2. Almost entirely yellow brown; wings uniformly hyaline, slightly fuscous (Fig. 3); length, ca. 6.0 mm; antenna 10-segmented, subclavate (Figs. 2, 9), length shorter than head width, with segments 4–8 serrate (Fig. 9); Queensland . . . . . *hyaloptera* Schmidt and Smith, n. sp.
- Black and reddish brown, dorsum of head, mesonotum, and legs largely black (Fig. 1); forewing patterned, subhyaline with dark brown at base and two dark brown bands (Figs 1, 8); length 7–11 mm; antenna 10 to 12 or 20-segmented, of almost uniform width, length longer than head width, with segments 3 to apex distinctly serrate (Figs. 1.b, 10) . . . . . 3
3. Antenna 10–12 segmented (Fig. 10); inner band of forewing not reaching posterior wing margin (Fig. 8); first tergite partly black; New South Wales, Queensland . . . . . *galla* Benson
- Antenna 20-segmented (Fig. 1.b); inner band of forewing reaching posterior wing margin (Fig. 1); first tergite reddish brown, concolorous with rest of abdomen; Tasmania . . . . . *bifasciata* (Brullé)
4. Wings uniformly slightly dusky; mesopleuron black; length, 5.0 mm . . . . . *hyaloptera* Schmidt and Smith, n. sp.
- Forewing patterned, subhyaline with dark brown at base and two dark brown bands (similar to Fig. 8); upper half of mesopleuron reddish brown; length, 8.0–9.0 mm . . . . . *galla* Benson

*Pteryperga bifasciata* (Brullé)  
(Fig. 1)

*Pterygophorus bifasciatus* Brullé 1846: 660–661, pl. 46, fig. 1, ♀ (here reproduced as Fig. 1); la Terre de Van Diemeni [Tasmania]; type lost.—Konow 1905: 37.

*Pteryperga bifasciata*: Benson 1938a: 625 (n. comb.).—Smith 1978: 148 (catalog).

Brullé's type is lost, and it is difficult to place this species from his description. It was described from a female from Tasmania. Froggatt's (1918, 1919) references to *Pterygophorus bifasciatus* belong to *P. galla* according to Benson (1938a), and this is confirmed here from Froggatt's specimens we have examined (see Dungay records for *P. galla*). It is unlikely Brullé's species is the same as *P. galla* or the other species described here, and, according to Benson (1938a), probably represents a distinct species of *Pteryperga*. *Pteryperga galla* females have a very distinctive colour pattern on the mesonotum and wings that is not found in any other known Australian pergid species. *Pteryperga bifasciata* shows a very similar colouration (Fig. 1), although the wing pattern does not quite agree with *P. galla* in that in the latter species the proximal band of the forewing does not reach the posterior wing margin (Fig. 1).

Furthermore, Brullé described and illustrated the antenna as 20-segmented, whereas in *P. galla* the female antenna is 10–12 segmented. Brullé did not mention preapical tibial spurs. Based on Brullé's description and illustrations we agree with Benson's opinion that *P. bifasciata* represents a distinct species, although this can be verified only when material is collected from Tasmania that may correspond to Brullé's description. Unfortunately, recent search of entomological collections in Tasmania for previously unrecorded material were unsuccessful (D. Bashford, pers. comm.)

*Pteryperga galla* Benson  
(Figs. 4, 5, 7, 8, 10, 11)

*Pterygophorus bifasciatus*: Froggatt 1918: 670 (biological note, ♀ ♂); Froggatt 1919: 112 (biological note); Morice 1919: 290 (brief description in key) [misidentifications].

*Pteryperga galla* Benson 1938a: 623–5. Holotype ♀, Australia, New South Wales, Tweed River, bred from cocoons collected by H. Brooks (ANIC, examined); condition of holotype: left foreleg, right middle leg, left hind tarsus, and left forewing missing, other wings partly damaged. Paratypes: 1 ♀, same data as holotype (ANIC); 2 ♀, same data as holotype (BMNH), 1 ♀, same data as holotype (ASCU), 3 ♀, New South Wales, Dorrigo (W.

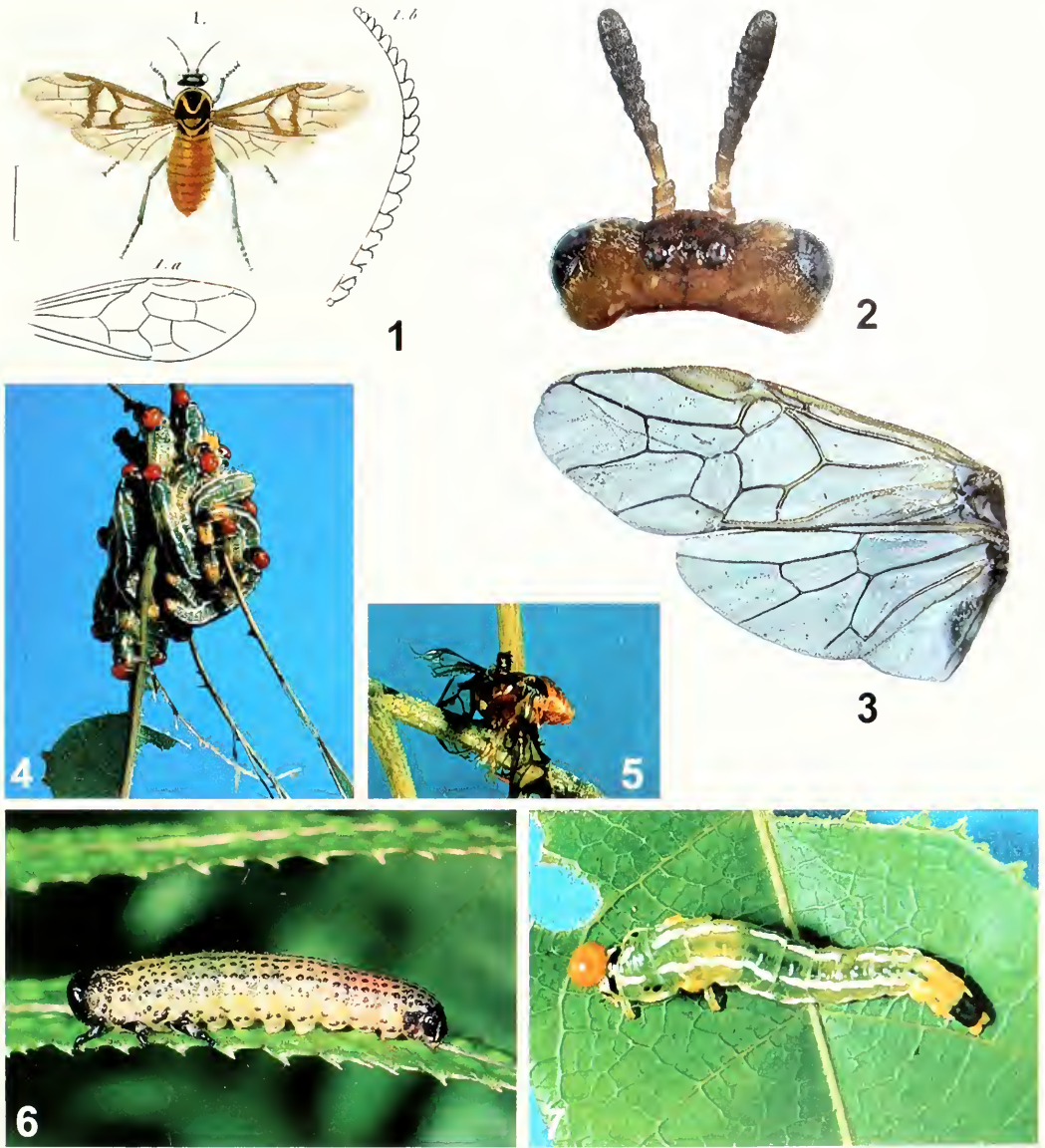

Figs. 1-7. 1, *Pteryperga bifasciata*, reproduction of *Pterygophorus bifasciatus*, fig. 1 in Brullé, 1846, adult female in dorsal view, forewing (1.a) and antenna (1.b). 2, 3, 6, *P. hyaloptera*. 2, Head of female in dorsal view. 3, Female wings. 6, Larva. 4, 5, 7, *P. galla*. 4, Cluster of larvae. 5, Dead adult female in guarding position. 7, Larva. Figs. 4, 5, 7, photographs by JM; Fig. 6, photograph by SS.

Heron) (SAMA).—Riek 1970: 891, 892 (host).—Smith 1978: 148 (catalog).—Macdonald and Ohmart 1993: 494 (biology).

*Female*.—Length 8.0–11.0 mm. Head reddish brown with postgena, lower gena, vertex except more or less ocellar furrows, epicranial suture, and frontal area dark

brown to black. Dark colouration sometimes more extensive with head mostly black and only face reddish brown. Thorax reddish brown with side lobes of mesoscutum, a broad median band on mesoscutal midlobe sometimes not reaching posterior end of midlobe so that reddish

brown pattern forms a V-shaped pattern (cf., Fig. 1), mesoscutellum anteriorly and posteriorly, mesosternum and lower 1/3 or less of mesopleuron, and occasionally 3 basal tarsal segments black. Abdomen reddish brown except first tergite with 2 black patches, and apex of sawsheath black. Wings fuscohyaline with a dark brown band across forewing from under basal part of stigma to hind margin and a second band from apex of costa along vein M, but not reaching hind margin of wing (Fig. 8); patches of dark brown fill intercostal area to some extent, cover basal and anal veins, and fill base of forewing (Fig. 8); hind wing with a slightly fuscous band from stigma and a fuscous patch covering anal veins; stigma and veins of wings black. Antenna 10–12 segmented, of almost uniform width, length slightly greater than head width, segments 3–10 distinctly serrate (Fig. 10). Postocellar area about 2.5× broader than long; distance between hind ocelli slightly greater than distance of a hind ocellus to posterior margin of head. Propleura narrowly rounded mesally. Foretibial spines subequal in length and width. Length of hind basitarsus equal length of following 1 1/3 tarsal segments. Length of longest hind tibial spur less than apical width of hind tibia. Head and body smooth, impunctate, shining. Sheath in dorsal view bifid, with long, posteriorly projecting scopae. Lancet (Fig. 11) and fig. 11 of Benson (1938a), with low, flat serrulae, serrulae on apical half or more not differentiated from each other.

*Male*.—Length 8.0–9.0 mm. Head black. Body predominantly black with pronotum except occasionally with black spot laterally, mesonotal midlobe laterally more or less, upper half of mesopleuron, and tegula reddish brown; forefemur apically, foretibia anteriorly, abdomen except most of basal 4 tergites, and tergites 5–6 medially black. Dark wing colour pattern similar to female, but less extensive. Antenna 15–16 segmented, slightly shorter than

maximum width of head, bipectinate, longest rami about half length of antenna or slightly longer; postocellar area about 4× broader than long, distance between hind ocelli slightly greater than distance of one of them to hind margin of head.

*Larva* (Figs. 4, 7).—Typically pergid-like with 3-annulate abdominal segments. Body smooth, ground colour green, apical segments yellow; head orange, shining; 10th tergum black; first and second segment of thorax dorsally with black markings; body with submedial and lateral broken longitudinal white stripes.

*Distribution*.—Australia: New South Wales, Queensland.

*Biology*.—Froggatt (1918, 1919), under the name *Pterygophorus bifasciatus* Brullé, recorded this species from cocoons in wood, "a colony, containing about twenty cocoons imbedded in soft wood from the stem of an undetermined tree." Riek (1970) recorded the host plant, *Elaeocarpus reticulatus* Smith (= *cyaneus* Aiton, Elaeocarpaceae), and Naumann (1991) mentioned that the larvae are on *Elaeocarpus* sp. Macdonald and Ohmart (1993) gave the most complete report of the biology, and JM here adds further observations. In summary, the female oviposits into the leaf margins of young *Elaeocarpus reticulatus* foliage and then takes up a "guarding position" on the associated leaf petiole remaining with her eggs and newly emerged larvae until her death (Fig. 5). Larvae are gregarious and development is synchronized. Sexual dimorphism is apparent in that female larvae are larger than males. Feeding is nocturnal, and larvae form aggregations during daylight hours (Fig. 4). Following larval development, the larvae move as an aggregation to find a suitable pupation site, off the host and usually in leaf litter. They make silken lined pupal cocoons in leaf litter or decaying timber. Adult emergence is synchronized; indications from larval collections suggest that the species is multivoltine.

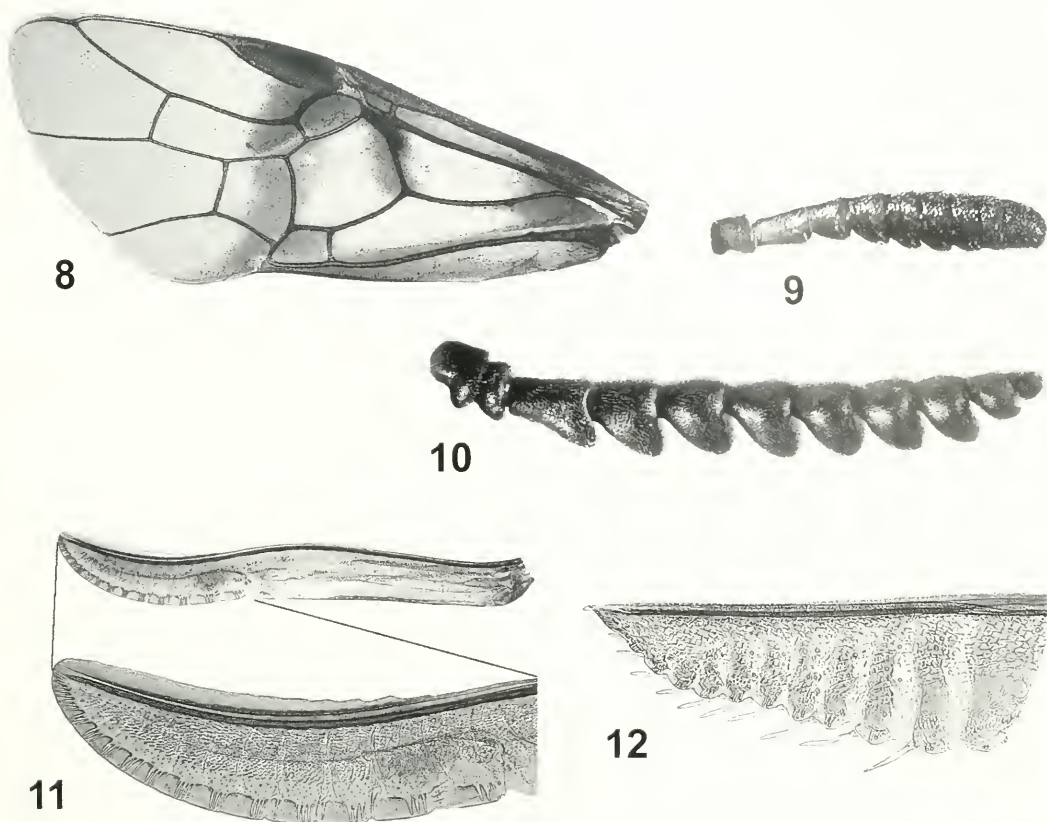

Figs. 8–12. 8, 10–11, *Pteryperga galla*. 8, Forewing. 10, Antenna in lateral view. 11, Lancet. 9, 12, *P. hyaloptera*. 9, Female antenna in lateral view. 12, Lancet.

*Material examined*.—New South Wales: Holotype ♀; 1 ♀, Dungay, 1917 (H. Brooks) ex larva; 1 ♀, Dungay (H. Brooks) (ANIC); 1 ♀, Dungay, 10.1917, from larva (Brooks) (USNM); 43 ♀, 10 ♂, Cromelin Field Station, Pearl Beach, 11.xii.1988 (J. Macdonald) ex larvae on *Elaeocarpus* sp. (ASCU). The specimens from Dungay were originally determined by Froggatt as *P. bifasciata* and subsequently used as the type series for *P. galla* by Benson.

*Pteryperga hyaloptera* Schmidt and Smith, new species  
(Figs. 2, 3, 6, 9, 12)

*Type*.—Holotype ♀, "6–7.11.1998, Bunya Mtns N.P., 26° 51'S, 151° 33'E, Australia, QLD, leg. S. & O. Schmidt," "Holotype *Pteryperga hyaloptera*, Schmidt & Smith."

Condition of holotype: perfect. Type deposited in ANIC. Paratype 1 ♀, 1–7.xii.99, Bunya Mts, Qld., Australia, S. Schmidt (ANIC) (last larval skin of this specimen preserved in ethanol together with paratype).

*Other specimen*.—1 ♂, 18 mls. N. of Gympie, Queensland, 23 April 1964, I.F.B. Common & M. S. Upton (ANIC).

*Female*.—Length, 6.0 mm. Yellow brown with apical 5–6 antennal segments, lateral lobes of mesonotum, lateral depressed areas of mesoscutellum, metathorax lateral to cenchri, abdominal terga (laterally yellow brown), and apical 3–4 tarsal segments dark brown to black. Mandible reddish brown. Metascutellum whitish. Wings uniformly slightly dusky; costa and stigma pale brown, rest of veins dark

brown to black (Fig. 3). Antenna subclavate, thickened toward apex (Figs. 2, 9), serrate with segments 4–8 in side view widened toward apices (Fig. 9), 10-segmented, length about  $0.75\times$  head width. Postocellar area about  $2\times$  broader than long; distance between ocelli much shorter than distance from ocellus to hind margin of head (Fig. 2). Propleura medioventrally acute on meson. Inner apical foretibial spur only slightly shorter and more slender than outer spur. Length of hind basitarsus shorter than following 2 tarsal segments combined. Length of hind apical tibial spurs less than apical width of hind tibia. Head and body smooth, shiny, almost impunctate. Sheath in dorsal view broad, triangular, not bifid. Lancet short, triangular (Fig. 12), serrulae low and rounded, each with a long posteriorly directed projection from anterior margin.

*Male*.—Length, 5.0 mm. Head black with antenna, clypeus, and labrum orange brown; mandible reddish. Thorax black with pronotum, perapterum, and narrow streak on lateral margin of mesonotal lateral lobes reddish brown. Legs black with apices of fore- and midtrochanters, apices of femora, and most of tibiae and tarsi orange yellow. Abdomen black. Wings uniformly slightly dusky, veins and stigma black. Antenna 16-segmented; length less than maximum width of head; bipectinate with longest rami more than half length of antenna. Postocellar area  $3.5\times$  broader than long; distance between hind ocelli  $2\times$  greater than distance of one of them to hind margin of head.

*Larva* (Fig. 6).—None preserved for study. Typically pergid-like with 3-annulate abdominal segments. Ground colour of body yellowish; head, most of thoracic legs, 10th tergum, and low tubercles on body black; tubercles forming longitudinal rows on body.

*Etymology*.—The name of the species refers to the wings which, unlike the other species of the genus, lack dark markings.

*Remarks*.—The paratype emerged from

a cocoon spun by the larva in Fig. 6; it is in poor condition but is obviously the same species as the holotype. The male described is from a separate collection and is not included as a paratype. Although not positively associated, we believe it is this species because of its similarity to the two females.

*Biology*.—Unknown. Though the larva was found on fern, it did not feed on any of the offered plants from the same locality, including several species of ferns. An extensive search for larvae on plants in the lower vegetation was not successful. Feeding marks that indicate the presence of sawfly larvae were not detected. Fern is probably not the host plant of *P. hyaloptera*, and the larva was probably on its way to the ground for pupation. It is possible that larvae of this species feeds in the canopy area. The locality where this species was collected is characterized by a high diversity of different species of trees and vines typical of subtropical rainforests in that region.

#### ACKNOWLEDGMENTS

We thank Mr. Dick Bashford, Forestry Tasmania, Hobart, for assistance with examining entomological collections in Tasmania for *P. bifasciata*; Ms. Cathy Anderson, Systematic Entomology Laboratory (SEL), U.S. Department of Agriculture, Washington, DC, who produced some of the photomicrographs; and Ms. Linda Lawrence, SEL, for producing Fig. 12. Acknowledgments are due to Drs. N. M. Schiff, U.S. Forest Service, Stoneville, MS, and S. W. Lingafelter and E. E. Grissell, SEL, for review and comments on the manuscript.

#### LITERATURE CITED

- Benson, R.B. 1938a. A revision of the genus *Pterygophorus* Klug, sensu lato, with the description of two new genera (Hymenoptera, Symphyta). *Annals and Magazine of Natural History* (11) 1: 610–625. (Published June, 1938.)
- Benson, R.B. 1938b. On the classification of sawflies (Hymenoptera Symphyta). *Transactions of the Royal Entomological Society of London* 87: 353–384. (Published 25 October 1938.)
- Brullé, A. 1846. Hyménoptères, Vol. 4, pp. 1–689. In Lepeletier, A.L.M., *Histoire Naturelle des Insectes*. Roret, Paris.

- Froggatt, W.W. 1918. Notes on Australian sawflies. *Proceedings of the Linnean Society of New South Wales* 43: 668–672.
- Froggatt, W.W. 1919. The re-discovery of a saw-fly. *The Australian Naturalist* 4:112.
- Konow, F.W. 1905. Familie Tenthredinidae. In Wytsman, P., *Genera Insectorum*. Bruxelles, 29, 176 pp.
- Macdonald, J. and C.P. Ohmart. 1993. Life history strategies of Australian pergid sawflies and their interactions with host plants, pp. 485–502. In Wagner, M.R. and K.F. Raffa, eds. *Sawfly Life History Adaptations to Woody Plants*. Academic Press, Inc., San Diego, 581 pp.
- Morice, F.D. 1919. Notes on Australian sawflies, with diagnostic synopses of the genera and species. *Transactions of the Entomological Society of London* 1918: 247–333, pls. XI–XV.
- Naumann, I.D. 1991. Hymenoptera (wasps, bees, ants, sawflies), pp. 916–1000. In CSIRO, *The Insects of Australia. A textbook for students and research workers*. Second Edition, Volume II. Melbourne University Press, Melbourne, pp. 543–1137.
- Riek, E.F. 1970. Hymenoptera (wasps, bees, ants), pp. 687–959. In CSIRO, *The Insects of Australia. A Textbook for Students and Research Workers*. Melbourne University Press, Melbourne, 1029 pp.
- Smith, D.R. 1978. Suborder Symphyta (Xyelidae, Pararchexyelidae, Parapamphiliidae, Xyelydidae, Karatavitidae, Gigasiricidae, Sepulcidae, Pseudosiricidae, Anaxyelidae, Siricidae, Xiphydriidae, Paroryssidae, Xyelotomidae, Blasticotomidae, Pergidae). In van der Vecht, J. and R.D. Shenefelt, eds. *Hymenopterorum Catalogus*. Pars 14. Dr. W. Junk B.V.—Publishers, The Hague, The Netherlands, 193 pp.

## Studies on *Neostromboceros albicomus* (Konow) (Hymenoptera: Tenthredinidae), a Potential Biological Control Agent for the Old World Climbing Fern, with Notes on Two Other Species of *Neostromboceros*

DAVID R. SMITH, A. D. WRIGHT, A. WINOTAL, AND R. DESMIER DE CHENON

(DRS) Systematic Entomology Laboratory, PSI, Agricultural Research Service, U.S. Department of Agriculture, <sup>c</sup> National Museum of Natural History, Smithsonian Institution, Washington, DC 20560-0168, USA, e-mail: dsmith@sel.barc.usda.gov; (ADW) USDA/ARS Australian Biological Control Laboratory, <sup>c</sup> CSIRO Entomology, 120 Meiers Road, Indooroopilly, 4068 Australia, e-mail: tony.wright@csiro.au; (AW) Division of Entomology and Zoology, Department of Agriculture, Chatchak, Bangkok, Thailand, e-mail: amporn@doa.go.th; (RDdeC) CIRAD-CP/IOPRI, Indonesian Oil Palm Research Institute, P.O. Box 37, Pematang Siantar, Sumatera, Utara, Indonesia, e-mail: roch.desmier-de-chenon@psiantar.wasantara.net.id

---

*Abstract.*—Three species of *Neostromboceros* have been reared from ferns in Thailand, Vietnam, Malaysia, and Indonesia. The biology, taxonomy, and distribution are presented for *N. albicomus* (Konow) on *Lygodium* spp. (Lygodiaceae), *N. congener* (Konow) on *Christella arida* (Thelypteridaceae), and *N. lucthi* Malaise on *Diplazium asperum* (Athyriaceae). *Neostromboceros albicomus* is a potential biological control agent for the Old World climbing fern, *Lygodium microphyllum* (Cavanilles) R. Brown, an invasive plant in southeastern United States. In the field, *N. albicomus* occurs on both *L. flexuosum* and *L. microphyllum* but attempts to rear insects from one plant host on the other were not successful. DNA sequencing of *N. albicomus* from the two hosts showed a single base difference between the two groups, indicating that two biotypes of *N. albicomus* may exist. *Stromboceros* (*Neostromboceros*) *metallica* Rohwer 1912 is a new synonym of *Neostromboceros albicomus* (Konow 1901).

---

*Lygodium microphyllum* (Cavanilles) R. Brown (Lygodiaceae), the Old World climbing fern (also known as the small-leaved climbing fern) native to southeastern Asia, is an invasive weed in the Everglades of Florida and is a target species for a USDA/ARS biological control program. During a search for biological control agents of this fern in southeastern Asia, three species of the genus *Neostromboceros* Rohwer were discovered feeding on ferns of the genera *Lygodium*, *Diplazium* (Athyriaceae), and *Christella* (Thelypteridaceae). Because so little is known of these sawfly species, and because of the potential for biological control by one of them, we present some data on their taxonomy, distribution, hosts, and life history.

The genus *Neostromboceros* is represented by about 45 species and occurs from Japan south to Papua New Guinea and Indonesia west to China, Nepal, and India (Malaise 1944, Naito 1979, Smith unpublished). It is one of the largest genera of the subfamily Selandriinae in this region, but nothing was known of its hosts and habits except for three of the six species in Japan, one of which feeds on *Athyrium japonicus* Copel, and two of which feed on *Athyrium* sp. (Athyriaceae) (Naito 1979). Since most Selandriinae feed on ferns and some adults of *Neostromboceros* have been collected from ferns, it has been assumed the larval host plants of most or all species are ferns. Malaise (1944) stated that adults are always found on or near lower ferns

in moist places, and inferred that ferns should be the food plant of the larvae.

Molecular characterization is increasingly being used as a method of indicating species diversity, identifying cryptic species, and matching immature stages with adults (Pemberton and Ferriter 1998, Goolsby et al. 2000). In this study, most collections of *Neostromboceros albicomus* (Konow), the most promising species for biological control and found throughout Thailand, Malaysia, and Vietnam, were the larval stage. Because larvae cannot be characterized morphologically, DNA sequencing was used to determine species status. This is discussed in the methods section and was used to determine larval identity and the distribution of *N. albicomus*.

#### METHODS

For identification of *Neostromboceros albicomus*, we sequenced the D2 expansion domain of the 28S rRNA which has proved useful for all life stages of insects and mites. Other genes such as ITS may be sequenced if finer resolution below the species level is needed, but this is much slower and more expensive than the automated sequencing of D2. The methods are those described by De Barro et al. (2000).

The polymerase chain reaction (PCR) was used to amplify the D2 gene regions for each specimen. Primers for the region followed Campbell et al. (1993); D2F 5'-CG TGTGCTTGATAGTGCAGC-3' and D2R 5'-TTGGTCCGTGTTTCAAGACGG-3', or ND2F 5'-AGTACCGTGAGGGAAAGTTG-3', which was used in some reactions as an alternate forward primer which anneals approximately 90 bases down stream of the D2F binding site. All reaction volumes were 50 $\mu$ L, containing 20pM of each primer, 200mM each dGTP, dATP, dCTP, and dTTP, 1.5–2.5mM MgCl<sub>2</sub>, 2 $\mu$ L DNA lysate, 1X supplied buffer and 2.5U Taq polymerase (Bresatec, Australia). PCR amplification was done using a Hybaid ther-

mocycler using the following parameters. A pre-cycle denaturation step for 5 min at 94°C, followed by the addition of the Taq polymerase. Then, 35 cycles of 1 min at 94°C, 1 min at 55°C and 1.5 min at 72°C followed by a final post-cycle extension step at 72°C.

Molecular characterization was used to determine species status for *Neostromboceros albicomus* larvae from *Lygodium*. *Neostromboceros congener* (Forsius) and *N. lucti* Malaise were not studied further because they were not found on the target food plant; however, we record new food plant data, biology, and distribution that we have available. The information given for *N. lucti* is an independent study by RDdeC.

Acronyms used are as follows: DEI = Deutsches Entomologisches Institut, Eberswalde, Germany; USNM = National Museum of Natural History, Smithsonian Institution, Washington, DC., USA.

#### SPECIES

##### *Neostromboceros albicomus* (Konow) (Figs. 1–6)

*Stromboceros albicomus* Konow 1901: 65.

*Neostromboceros albicomus*: Forsius 1933: 169, 183 (Malaysian records); Malaise 1944: 45 (syn.: *S. cenchralsis* Konow).

*Stromboceros cenchralsis* Konow 1908: 149.

*Stromboceros* (*Neostromboceros*) *metallica* Rohwer 1912: 236; Forsius 1933: 169; Malaise 1944: 44.

##### New synonymy.

*Recognition*.—Adults (Fig. 3) black, abdomen with middle tergites reddish, sometimes appearing as central band; wings hyaline with apical part of forewing beyond stigma infuscate. Third antennal segment longer than 4th; antenna round, not compressed, slightly incrassate in middle. Anterior margin of clypeus slightly emarginate; head smooth and shiny, without punctures (Fig. 1); without antennal furrows lateral to frontal area; antennal sockets not carinate; lateral supra-antennal pits circular, connected by a short furrow to antennal sockets; malar space



Figs. 1–2. *Neostromboceros albicomus*. 1, Head, frontodorsal view. 2, Sawsheath and ovipositor.

linear; postocellar area broader than long; head strongly narrowing behind eyes. Mesopleuron smooth, shining; epicnemium indistinct, almost wanting. Female sheath slender, from above of uniform width; sheath and ovipositor as in Fig. 2.

This is one of the few species of *Neostromboceros* with part of the abdomen red; most species have a black abdomen with the posterior margin of the segments narrowly white. The above characters will separate this species from other species with part of the abdomen red.

*Discussion.*—Forsius (1933) mentioned that *N. albicomus* and *N. metallicus* were probably synonymous. Malaise (1944) separated *N. metallicus* and *N. albicomus* (= *cenchrallis*) in his key to species, both going to the same couplet. He did not see Rohwer's type of *metallicus* (mentioning "after Rohwer"), so he was unable to compare it with the type of *N. albicomus*. He men-

tioned seeing both types (*albicomus* and *cenchrallis*), and two females. In a footnote, he stated "That *N. metallicus* is really specifically different from *albicomus* is uncertain and needs confirmation." DRS compared types of *metallicus* and *albicomus* side-by-side and concluded that *N. metallicus* is a new synonym of *N. albicomus*; the previous synonymy of *chechrallis* is also confirmed.

Konow (1901) described *Stromboceros albicomus* from "Malacca (Perak)" and stated it was in the "Mus. Hung." He described the female but did not give the number of specimens he had. We examined one syntype in the DEI labeled "Perak," "Coll. Konow," "Syntypus," "Stromboceros albicomus Knw., Perak."

Konow (1908) described *Stromboceros cenchrallis* from "Insulae Philippinae (Palawan)." He described the female but did not state how many specimens he had. We examined one female in the DEI labeled "Palawan," "Coll. Konow," "Holotypus," "Stromboceros cenchrallis Knw., Ins. Philipp."

Rohwer (1912) described *Stromboceros* (*Neostromboceros*) *metallica* from "Singapore, Malay Peninsula. One female collected February 25, 1909, by Bryant and Palmer." It is the type species of *Neostromboceros* Rohwer, described as a new subgenus. The holotype in the USNM is labeled: "Singapore Malay Penin," "Bryant & Palmer Coll.," "Hym Slide 307," "wing mounted," "♀ Type No. 14505 U.S.N.M.," "Neostromboceros metallicus Roh., TYPE ♀."

*Hosts.*—*Lygodium flexuosum* (Linnaeus) Swartz and *L. microphyllum* (Lygodiaceae). Larvae fed and completed their live cycle on *L. salicifolium* Presl, but adults did not oviposit on this species.

*Biology.*—AW maintained colonies of this "Lygodium sawfly." Larvae were collected on *Lygodium flexuosum* growing along roadsides at Hui Nam Rin, Wiang Pa Pao District, Chiang Rai Province in northern Thailand and taken to the labo-

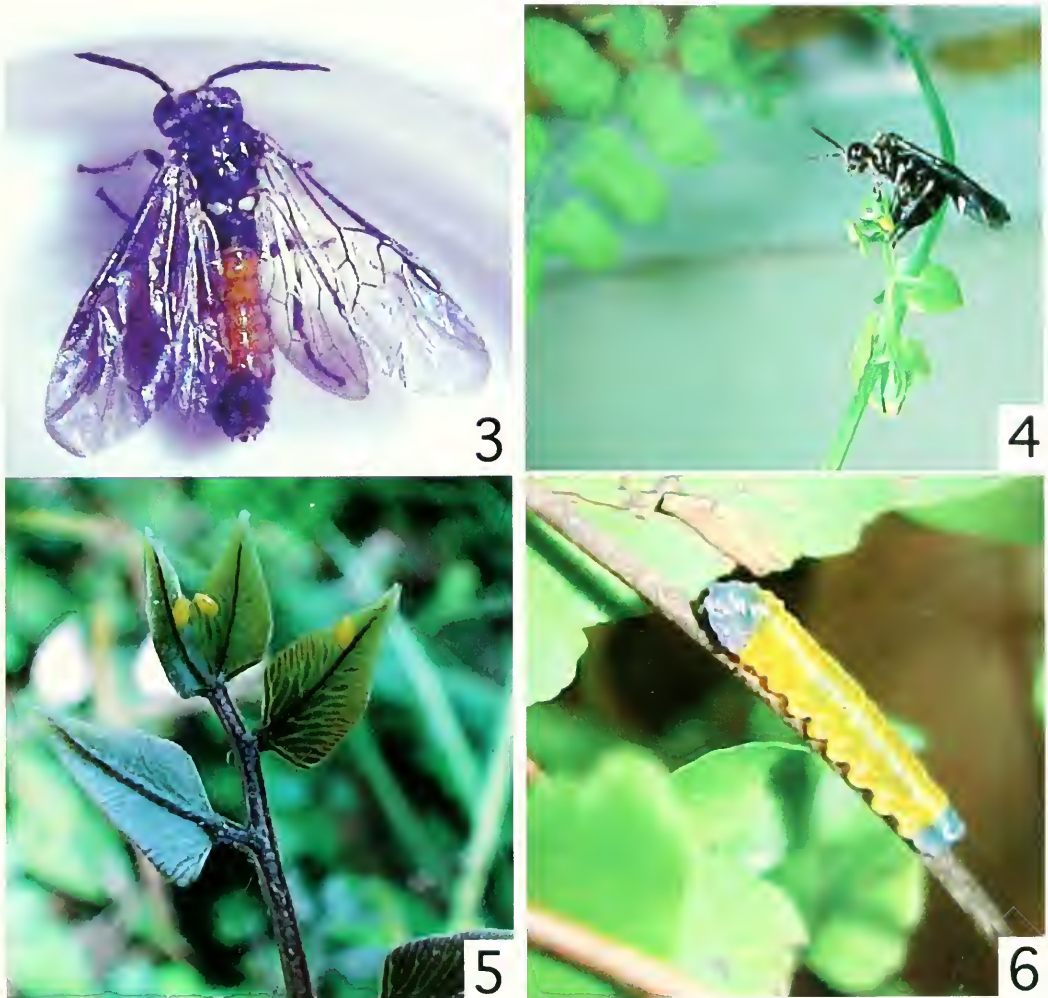

Figs. 3–6. *Neostromboceros albicomus*. 3, Female. 4, Female ovipositing on *Lygodium flexuosum*. 5, Eggs on *L. flexuosum* shoots. 6, Larva on *L. flexuosum*. Photos by A. D. Wright and A. Winotai.

ratory in Bangkok. During preliminary biological studies at 25°C, unmated females laid eggs (Fig. 4) a few hours after emergence. Yellow oval eggs were laid singly on young shoots and leaves (Fig. 5) and became orange yellow before hatching. Eye spots were visible through the chorion. Newly hatched larvae were pale with dark head capsules. Large larvae were yellow with small purple bands at the anterior and posterior ends of their bodies (Fig. 6). Full grown larvae moved into the soil where they formed cocoons and pupated. In laboratory studies, adult sawflies

were fed a honey solution. Duration studies indicated a preoviposition period of 1–2 hours and an egg incubation period of 3–5 days. Some larvae had 4 instars and some 5 instars, but it was not determined if the numbers related to sexes. The total larval period was 20–22 days and the pupal period was 15–21 days. The adult longevity was 3–4 days.

Observations on feeding and oviposition behavior of *N. albicomus* indicated differences according to whether larvae were collected on *Lygodium flexuosum* or on *L. microphyllum*. The presence on two food

plants suggest that *N. albicomus* may have two biotypes so far indistinguishable by morphological taxonomy, and this appears to be supported by results of DNA sequence results referred to in the distribution section below. Sequencing was done on eight specimens collected from *L. flexuosum* and three from *L. microphyllum*. The sequences separated into two groups with a single base difference between them, according to the host plant. Within each group, there was no variation in the sequenced D2 gene. Sequences for the two groups are deposited in GenBank, accession numbers AF453417 and AF 453418.

(A) Collections on *L. flexuosum*: Observations on feeding behavior indicated that *N. albicomus* larvae collected on *L. flexuosum* preferred feeding only on *L. flexuosum*. Limited host-specificity testing indicated the sawfly fed and completed its life cycle on *L. microphyllum* and *L. salicifolium*, but it did not feed on ten ornamental ferns of the genera *Adiantum* (Adiantaceae), *Asplenium* (Aspleniaceae), *Nephrolepis* (Nephrolepidaceae), *Davallia* (Davalliaceae), or *Pteris* (Pteridaceae). In both Bangkok and Brisbane studies, adults appeared reluctant to oviposit on *L. microphyllum*, and, though larvae placed on *L. microphyllum* survived, they took longer to develop, there was high mortality, and emerged adults did not lay any eggs. Although *L. japonicum* (Thunberg) Swartz has yet to be tested with larvae collected on *L. flexuosum*, we speculate it may also be a suitable host plant of *N. albicomus*, since the morphological similarity of *L. flexuosum*, *L. salicifolium*, and *L. japonicum* indicates they are probably closely related (P. Bostock, pers. comm.).

(B) Collections on *L. microphyllum*: Observations indicated *N. albicomus* collected on *L. microphyllum* preferred feeding only on *L. microphyllum*. When supplied *L. japonicum*, both cut foliage and whole plants, larvae failed to feed and died. Adults provided with a choice of *L. microphyllum*, *L. japonicum*, and *L. flexuosum* laid

most eggs on *L. microphyllum*, none on *L. japonicum*, and only three were seen on *L. flexuosum*.

*Distribution*.—The following records are confirmed by us. DNA sequencing was carried out on specimens (mostly larvae) collected at various places from Thailand, Malaysia, and Vietnam, and results indicated all were the same species, with exact sequence matches (collections from *Lygodium flexuosum*) denoted by a single asterisk (\*) and at the same single base difference (in collections from *Lygodium microphyllum*) denoted by a double asterisk (\*\*). MALAYSIA: Selangor: Kuala Lumpur, 1 August 1983, G.F. Hevel & W. E. Steiner (1); Perak, Kuala Woh, 1 September 1992, leg. D.G. Furth (1); \*Kuala Lumpur, Taman Cheras Muda, 3° 06.2'N, 101° 05.2'E, 4 July 1999, larvae on *Lygodium flexuosum*, H. L. Ho; Kuala Lumpur, Cheras, Taman Seraya, 3° 06.9'N, 101°45.4'E, 8 November 1999, larvae on *Lygodium flexuosum*, A. D. Wright & H. L. Ho; \*Kedah, Langkawi, 5 June 1999, larvae on *Lygodium flexuosum*, H. L. Ho; \*Pahang, 22 km E of Maran on highway #2, 3° 40.7'N, 102° 54.9'E, 12 August 1999, larvae on *Lygodium flexuosum*, A. D. Wright & H. L. Ho. PHILIPPINES: Palawan. SINGAPORE: "Singapore." THAILAND: \*Chiang Rai Province, Wiang Pa Po District, nr. Huai Nam Rin, side road ca. 70 km NE of Chiang Mai on road #1019, 19° 05.9'N, 99°27.5'E, 30 August 1998, larvae on *Lygodium flexuosum*, A. D. Wright & A. Winotai; \*Surat Thani Province, Don Sak District, roadside nr. Ban Pang Nga Shee, 9° 13.5'N, 99°39.3'E, 1 December 1998, eggs and larvae on *Lygodium flexuosum* (nearby *L. microphyllum* had no sawflies or sawfly damage), A. Winotai & A. D. Wright (reared 1 ♀); \*Narathiwat Province, Yi-ngo District, rubber plantation in Luhbohlausa, 6° 25.5'N, 101° 41.7'E, 20 April 1999, 8 August 1999, larvae on *Lygodium flexuosum*; Narathiwat Province, Tak Bai District, 25 February 2001, larva on *Lygodium microphyllum*, A. Winotai & A. D. Wright;

\*Chiang Mai Province, San Sai District, nr. Ban Pong, 18° 55.3'N, 99° 2.9'E, 27 April 1999, 29 April 1999, 5 August 1999, eggs and young larvae on *Lygodium flexuosum* (4 larvae with tachinid eggs, 4 tachnid adults emerged in quarantine, Brisbane), A. Winotai & A. D. Wright; \*Rayong Province, Kao Chamao Subdistrict, nr. Klong Pla Kang Waterfall, nr. Samkor Village, 12° 56.0'N, 101° 42.9'E, 13 May 1999, larvae on *Lygodium flexuosum*, A. Winotai & A. D. Wright; Trat Province, Klong Yai District, Tambol Mai Root, Ban Huang Som, 11°50.1'N, 102° 50.6'E, 3 April 2001, larvae on *Lygodium microphyllum*, A. Winotai; \*\*Trat Province, Klong Yai District, Tambol Mai Root, Ban Huang Som, 11° 50.1'N, 102° 50.6', 3 April 2001, larvae on *Lygodium microphyllum*, A. D. Wright & A. Winotai. VIETNAM: \*\*nr. Ho Chi Minh City, larvae on *Lygodium microphyllum*, 23 October 1996, Thai Van.

Malaise (1944) gave the distribution as: "The Malay Peninsula (Perak; Keday [Gurum; Catchment Area near Jitra]; West Coast [Langkawi Island; Pulo Pinang]; East Coast [Pulo Aor]); The Philippines (Palawan)." Forsius (1933) recorded: Malay Peninsula: Kedah, Garun, November–December 1916; Keday, Catchment Area near Jitra, 7–10 April 1928; Malay Peninsula, West Coast, Langkawa Islands, 19 April–1 May 1928, 20 August 1928.

### *Neostromboceros congener* (Konow)

*Stromboceros congener* Konow 1901: 64.

*Neostromboceros congener*: Forsius 1934: 110 (Java); Malaise 1944: 40 (syn.: *S. karnyi* Forsius).

*Stromboceros karnyi* Forsius 1931: 33; Forsius 1934: 107, 110 (additional distribution records).

**Recognition.**—Adults black with following white: labrum, posterior margin of pronotum, anterior margin of tegula, perapterum, narrow posterior margin of tergites, apices of coxae, trochanters, apices of femora, and basal part of tibiae; wings hyaline, forewing only slightly subinfus-

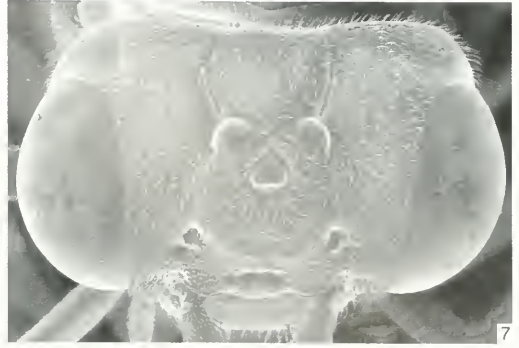
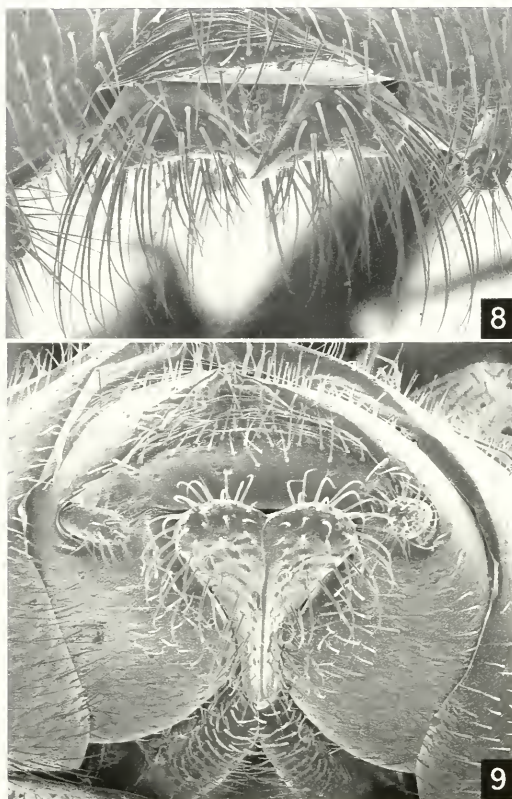

Fig. 7. *Neostromboceros lucti*, frontodorsal view of head.

cate toward apex. Antenna almost round in cross section, not distinctly compressed but faintly more compressed in male; flagellar joints without hair-brushes; 3rd segment slightly longer than 4th. Clypeus truncate or with very shallow anterior emargination; malar space linear; head smooth and shining, without punctures; no distinct furrows lateral to frontal area; lateral ocellar furrows distinct; postocellar area subquadrate, slightly broader than long; inner margins of eyes parallel in female, slightly converging below in male. Thorax and abdomen smooth and shiny, without punctures. Female sawsheath slender, in dorsal view of uniform width.

The black coloration with the above parts white, lack of punctures on the head and body, nearly truncate clypeus, and the third antennal segment slightly longer than the fourth will recognize this species. The above characters will separate this species from other species that are mostly black and lack punctures on the frontal area.

**Discussion.**—Konow (1901) described *Stromboceros congener* from "Lombok (Sapit)" and stated it was in "Mus. Hung." He did not state how many specimens he had, but he described both sexes. One female at DEI is labeled "Lombok, Sapit 2000", Mai-Juni 1896, H. Fruhstorfer," "Coll. Konow," "Syntypus," "*Stromboceros congener* Knw., Lombok." Also one female



Figs. 8–9. *Neostromboceros luchti*. 8, Sawsheath, dorsal view. 9, Sawsheath, posterior view.

bears the same data but lacks a determination label. Two other females are labeled "Kelantin," "Coll. Konow," but they cannot be types because the locality differs from that of the original description.

Malaise (1944), in his key to *Neostromboceros*, mentioned seeing 30 females and 15 males of congener (= *karnyi* Forsius), some of them compared with the types.

*Host*.—*Christella arida* (D. Don) Holttun (Thelypteridaceae), collected by ADW in northern Sumatra (identity confirmed by P. Bostok).

*Distribution*.—We examined specimens from the following: INDIA: Buxar Duar.

Bengal, D. Nowrojee, 5.1907 (1); Kobo, 400 ft., Arbor Exped., 3-XII-11, Kemp (1); Sadiya, 21–25 May 1920, Fletcher Coll. (2); "India" 1952, G. W. Angelet (1). INDONESIA: Lombok, Sapit, 2000'; North Sumatra, roadside on track near Lake Toba, 2° 44.7'N, 98° 53.2'E, 22 May 1999, A. D. Wright, collector, adults resting and larvae feeding on ferns, 2 adults and 1 larva on fern *Christella arida*, A. D. Wright & R. Desmier de Chenon. MALAYSIA: Up-Perak, 1902 (1).

Malaise (1944) recorded the distribution as "Lombok; Eastern Java (Bondowoso, 1–1500 m.; G. Raoeng, 450–700 m.; etc.)." Forsius (1934) gave "Zwei Weibchen und drei Männchen aus Buitenzorg, Dezember 1931. Ein Männchen aus Malang, November 1931." Forsius (1931) described *S. karnyi* from "Java, Tjibodas, 1400 bis 1500 m."

### *Neostromboceros luchti* Malaise

(Figs. 7–14)

*Neostromboceros luchti* Malaise 1944: 31.

*Recognition*.—Adults (Fig. 10) black with purplish tinge and with following white: labrum, posterior margin of pronotum, perapterum, trochanters, and basal stripe on tibiae; wings hyaline with apical half of forewing infusate from base of stigma. Head with frontal area almost flat, distinctly punctured or rugose with punctures confined to frontal area (Fig. 7). Clypeus truncate; malar space linear; postocellar area broader than long, subconvex; lateral postocellar furrows convexly curved, reaching back of head; middle supra-antennal pit transversely furrow-like, almost straight and shallow; lateral furrows rounded or semicircular with tubercle in middle; lower half of hind orbits carinated. Mesopleuron smooth, shiny, im-

Figs. 10–14. *Neostromboceros luchti*. 10, Female. 11, Eggs on *Diplazium asperum*. 12, Larva. 13, Larvae feeding on *D. asperum*. 14, Cocoon. Photos by R. Desmier de Chenon.



punctate. Female sawsheath strongly dilated at apex (Figs. 8, 9).

The black coloration with the above parts white, punctured frontal area of the head, and strongly dilated female sawsheath will distinguish this species. The above characters are intended to separated this species from other species that are mostly black and have punctures on the frontal area.

*Host.*—*Diplazium asperum* Blume (Athyriaceae) (identity confirmed by P. Bostok).

*Biology.*—This species was reared in Indonesia by RDdeC. The host is a common understory fern in oil palm plantations. The complete cycle from egg to adult takes about 22 to 30 days to complete. Incubation period for the eggs is three to four days, larval development about 20 days, and the time from pupation to eclosion is about 9 to 10 days. The male goes through five instars, and the female six instars. Results of feeding experiments indicate that a single larva consumes about 29 square centimeters of plant tissue during its development. The average number of eggs per dissected female is about 59 with a range of 40 to 98 in 14 specimens dissected. The size of the eggs ranges from 1.12 to 1.18 mm in length and 0.36 to 0.46 mm in width. Eggs are laid on the underside of the frond (Fig. 11), and the number of eggs laid per frond averages about 64, about 41% of which hatched. The larva (Fig. 12) is shiny, green with a darker green dorsum, and many can be found feeding on a fern frond (Fig. 13). The cocoon in the ground is made up of particles of soil (Fig. 14).

*Distribution.*—INDONESIA: Sumatra, Province of North Sumatra, Bagun Bandar Estate (oil palm plantation), 3°19.62'N, 99°01.76'E (rearings by RDdeC); "Java (Bondowoso, 1000–1500 m; G. Raoeng, 450–700 m, Buitenzort)" (Malaise 1944). MALAYSIA: Kuala Lumpur (Malaise 1944).

## ACKNOWLEDGMENTS

We thank A. Taeger and S. M. Blank, Deutsches Entomologisches Institut, Eberswalde, Germany, for allowing study of Konow's type material. Peter Bostock, Queensland Herbarium, Brisbane, identified the species of *Christella* and *Diplazium* and checked family names of the ferns. Winai Somprasong, DOA Herbarium, Bangkok, confirmed identifications of ferns used in preliminary host testing in Bangkok. John Curran, Felice Driver, and Diana Hartley, CSIRO Entomology, undertook the DNA sequence comparisons of *N. albicomus* specimens from Malaysia, Thailand, and Vietnam. Valuable assistance with specimen collections was provided by Ho Haw Leng in Peninsular Malaysia and by Cherd Chuyang and Nisit Channarat in northern Thailand. We thank Stefan Schmidt, CSIRO Entomology, Canberra, for valuable discussions and suggestions on rearing sawflies. Cathy Anderson, Systematic Entomology Laboratory, U.S. Department of Agriculture, Washington, DC, took the SEM's and arranged the plates. Acknowledgments are due to N. M. Schiff, U.S. Forest Service, Stoneville, MS, and M. G. Pogue and E. E. Grissell, Systematic Entomology Laboratory, U.S. Department of Agriculture, Washington, DC, for review and comments on the manuscript. We thank R. V. Greene, Office of International Research Programs, ARS, U. S. Department of Agriculture, Beltsville, MD, for allowing publication of two plates in color.

## LITERATURE CITED

- Campbell, B., J. D. Steffen-Cambell, and J. H. Werren. 1993. Phylogeny of the *Nasonia* species complex (Hymenoptera: Pteromalidae) inferred from an internal transcribed spacer 1TS2 and 28S rDNA sequences. *Insect Molecular Biology* 2: 225–237.
- De Barro, P. J., F. Driver, I. D. Naumann, G. M. Clarke, and J. Curran. 2000. Descriptions of three species of *Eretmocerus* Haldemann (Hymenoptera: Aphelinidae) parasitising *Bemisia tabaci* (Gennadius) (Hemiptera: Aleyrodidae) and *Trialeurodes vaporariorum* (Westwood) (Hemiptera: Aleyrodidae) in Australia based on morphological and molecular data. *Australian Journal of Entomology* 39: 259–269.
- Forsius, R. 1931. Über einige neue oder wenig bekannte orientalische Tenthredinoiden (Hymenopt.). *Annalen des Naturhistorischen Museums in Wien* 46: 29–48.
- Forsius, R. 1933. Notes on a collection of Malaysian Tenthredinoidea (Hym.). *Bulletin of the Raffles Museum* 8: 169–193.
- Forsius, R. 1934. Über einige Tenthredinoiden Javas. *Revue Suisse de Zoologie* 41:105–110.
- Goolsby, J., T. Wright, M. Purcell, J. Makinson, and

- R. Zonneveld. 2000. 2000 Annual Report: USDA-ARS Australian Biological Control Laboratory. Unpublished Report.
- Konow, F. W. 1901. Neue Chalastogastra-Arten (Hym.). *Természeti Füzetek* 14: 57-72.
- Konow, F. W. 1908. Neue mittel- und südamerikanische Tenthrediniden (Hym.). *Zeitschrift für Systematische Hymenopterologie und Dipterologie* 8: 144-163.
- Malaise, R. 1944. Entomological Results from the Swedish Expedition 1934 to Burma and British India. Hymenoptera: Tenthredinoidea. Collected by René Malaise. The Tenthredinoidea of South-Eastern Asia. *Arkiv för Zoologi* 35A: 1-58.
- Naito, T. 1979. Japanese species of the genus *Neostromboceros* Rohwer (Hymenoptera: Tenthredinidae). *Akita*, N.S. 23: 1-8.
- Pemberton, R. W. and A. P. Ferriter. 1998. Old World climbing fern (*Lydogium microphyllum*) a dangerous invasive weed in Florida. *American Fern Journal* 88(4):165-175.
- Rohwer, S. A. 1912. Notes on sawflies, with descriptions of new species. *Proceedings of the United States National Museum* 43: 205-251.

## Review of the *Glyptapanteles* species (Hymenoptera: Braconidae, Microgastrinae) Attacking Noctuids in Field Crops in the Neotropical Region, with Descriptions of Two New Species from the Ecuadorian Andes

JAMES B. WHITFIELD, ALBRECHT BENZING, AND FERNANDO PONCE

(JBW) Department of Entomology, University of Illinois, Urbana, IL 61801, USA; (AB) Fachgebiet Ökologischer Landbau, Nordbahnhofstrasse 1A, 37213 Witzenhausen, Germany; (FP) Escuela Radiofónicas Populares, Cas. 06-01-693, Riobamba, Ecuador

---

*Abstract.*—The six species of *Glyptapanteles* Ashmead known to attack noctuid pests in the New World are reviewed, with illustrated identification keys and discussions of their species status and possible relationships. Four of the species have been previously described: *G. bourquini* (Blanchard), **new combination**, *G. herbertii* (Ashmead), *G. militaris* (Walsh) and *G. muesebecki* (Blanchard), **new combination**. Two are newly described here: *G. ecuadorius* Whitfield and *G. agrotivorus* Whitfield.

---

Microgastrine braconid wasps are among the principal natural enemies of noctuid and other lepidopteran pests throughout the world (Whitfield, 1997). A large percentage of the microgastrine Braconidae attacking noctuids, especially in the temperate zones, belong to the genus *Cotesia* Cameron, probably one of the two largest genera of this subfamily with perhaps as many as 1,500 species worldwide (Mason, 1981). In the Neotropics, this dominant position of *Cotesia* is to some extent displaced by species in the genus *Glyptapanteles* Ashmead. This latter genus has never been revised in the neotropical region, so that identification of species, even those reared from agriculturally important pest species, can be difficult or impossible without repeated visits to museums with important reference material.

In this paper we review those New World species of *Glyptapanteles* known to have been reared from agricultural pests in the family Noctuidae. We have not attempted to cover all species that might be reared from noctuids outside field crop situations. The species treated here are a

mix of principally Nearctic species with ranges extending into the Caribbean region (and occasionally into South America due to introductions), and of essentially South American species which also, in some lowland species, have ranges extending north through the Caribbean into the southern U. S., especially Florida. In reviewing these species, we describe two new ones encountered in the course of studies on natural enemies of noctuid pests in corn and vegetable fields in the central highlands of Ecuador.

### MATERIALS AND METHODS

Larvae of several species of Noctuidae were collected by random sampling throughout the corn growing seasons (October to May) on small fields in Ecuador between 2,000 and 3,250 m elevation. In addition, collections were also made on a 7 ha experimental organic farm near Riobamba (2,750 m el.), where vegetables are grown year round. Larvae of Lepidoptera were then identified using the key from Angula and Weigert (1975) and our own drawings. They were reared in plastic cag-

es (5 cm diameter × 1.5 cm height) with their natal host plants. When parasitoids emerged from the larvae, they were left in the cages until adults eclosed, which were then pinned.

Our Ecuadorian parasitoid material was then compared with holotypes and other determined material from the senior author's collection as well as from several major museums (see descriptions and Acknowledgments for details), as well as to the original descriptions of the New World *Glyptapanteles* species known to attack noctuids. Wings were removed from adult females, mounted between two glass slides, and projected using a microprojector for tracing and shading. Metasomata were removed from some females, sepa-

rated into anterior and posterior halves using minuten needles and mounted in Euparal so that the anterior halves were visible in dorsal view and the posterior halves were visible in lateral view. These were then drawn using ocular grids in a Zeiss DRC microscope at 63×, and squared paper. In a few cases the metasomal features were drawn directly from point-mounted material. Cocoons were photographed using a Sony MVC FD90 digital camera with close-up lenses; natural lighting was supplemented with fibre optic lighting.

Morphological terminology follows that used in Sharkey and Wharton (1997) and Whitfield (1997). The descriptions presented below are to be attributed to the senior author.

KEY TO GLYPTAPANTELES FROM AGRICULTURAL NOCTUIDS IN THE NEOTROPICAL REGION

*Note:* Species of the microgastrine genera *Cotesia* and *Microplitis* are also commonly reared from noctuids. Specimens can first be identified to genus using Whitfield (1997). Readers may also wish to check the generic diagnosis of *Glyptapanteles* by Mason (1981). Care should be taken, when using the following key, that good soft (dispersed) lighting (such as with a ring light or through frosted glass or mylar) is available. In this way the fine sculpturing features on the first metasomal tergite in some species is visible, as is the true outline of the second tergite. These features can be difficult to discern accurately with harsh lighting since many of the specimens are so shiny. Slide mounting of metasomata can also be useful for discerning the finer features.

1. Junction of r and 2Rs in fore wing marked by a small knob, with r much longer than 2Rs (Fig. 1); first metasomal tergite somewhat sculptured and rounded posteriorly, second tergite often not well demarcated from third medioapically (Fig. 2); cocoon mass typically tightly spun together, occasionally looser, cocoons woolly, tan to orangish or pinkish in color (Fig. 19) ..... *G. bourquini* (Blanchard)
- Junction of r and 2Rs in fore wing not marked by small knob, rounded to obtusely angled and with r and 2Rs fairly equal in length (Figs. 4, 7, 10, 13, 16); first metasomal tergite usually more evenly narrowing from base to apex, second tergite always well demarcated from third medially by narrow suture (Figs. 5, 8, 11, 14, 17); Cocoon masses variable (Figs. 20–24), but usually not tightly spun together in a mass (except in *G. herbertii*, where it is elongate with cocoons arranged like stacked wood—Fig. 22) ..... 2
2. First metasomal tergite with some distinct, but often very fine, punctuation in apical half (Fig. 5), not highly polished apically; cocoon mass tan in color, elongate and with cocoons arranged and stacked in parallel as with stacked wood (Fig. 22) ... *G. herbertii* (Ashmead)
- First metasomal tergite smooth and relatively polished throughout (Figs. 8, 11, 14, 17); cocoons variable, but typically not spun in an organized cluster although sometimes kept together by loose woolly threads (Figs. 20, 21, 23) ..... 3
3. Hind coxa predominantly, typically entirely, bright yellowish in color, as is tegula; cocoons loosely spun together and white to light buff in color (Fig. 20) ..... *G. militaris* (Walsh)
- Hind coxa mostly dark brown to blackish, at least basally; tegula and cocoons variable ... 4
4. Second metasomal tergite about twice as broad posteriorly as long medially (Fig. 14), often with central part raised slightly, so that it may superficially appear less broad ..... *G. ecuadorius* Whitfield, n. sp.

- Second tergite much less than  $2\times$  as broad posteriorly as long medially, usually about 1.4X as broad or less (Figs. 11, 17) . . . . . 5
  - 5. First metasomal tergite at least  $1.5\times$  as long as anteriorly broad, and evenly narrowing posteriorly, with relatively straight lateral margins (Fig. 11); tegula pale yellowish brown; cocoons yellowish brown, spun in a loose mass (Fig. 21) . . . . . *G. muesebecki* (Blanchard)
  - First metasomal tergite shorter, with more curved (convex) lateral margins rounding to apex (Fig. 17); tegula dark brown; cocoons white, loosely spun in a cluster with much loose silk (Fig. 23) . . . . . *G. agrotivorus* Whitfield, n. sp.
- 

## SPECIES NOTES AND DESCRIPTIONS

### *Glyptapanteles bourquini* (Blanchard)

(Figs. 1–3, 19, 24)

*Apanteles bourquini* Blanchard: 137. Type, Blanchard collection, Buenos Aires, examined. Portions of Blanchard's material and other reared material also examined in United States National Museum, Washington (USNM).

*Apanteles elegans* Blanchard 1936: 139. Type, Blanchard collection, Buenos Aires, examined. This and other material referred to as *elegans* appear to be conspecific with *G. bourquini*. **New synonymy.**

Blanchard (1936) described *bourquini* and *elegans* in consecutive pages of his treatment of Argentinian microgastrines. According to his descriptions, the distinguishing features of the two are slightly shorter distal antennomeres in *bourquini*, slightly shorter fore wing 1Rs in *elegans*, and the color of the cocoon masses of the two species, those of *bourquini* being a more brownish white, while *elegans* spins masses of a more orange-brown color. In the material we have seen, cocoon color varies between these extremes, and the antennomere length difference does not appear to hold up. The latter is also sexually dimorphic in each species, so that it is possible that Blanchard actually described a male antenna for *elegans* and a female for *bourquini*. Most reared material appears to resemble Blanchard's wing figure for *bourquini* (see Fig. 1), with some tendencies towards the *elegans* configuration for 1Rs. Finally, both species are stated in the description to have been reared from *Psora-*

*grotis* (*gypaetina* Gn. in the case of *bourquini*, and an undetermined species in the case of *elegans*). Shenefelt (1972), summarizing available published host records, listed, in addition to these species, *Peridroma margaritosa* (Haw.), *Pseudaletia unipuncta* (Haw.) and *Agrotis ipsilon* (Hfn.) for *bourquini*, and the first two of these also for *elegans*. It seems most likely that only one species of *Glyptapanteles* (a) attacks this set of hosts, (b) looks like *bourquini*, and (c) spins the characteristic compact cocoon mass attributed to these two species. Obviously there is some variation in the cocoon mass color, from tan or slightly pinkish through more orange-brown shades. We thus treat *elegans* as a junior synonym of *bourquini*.

In our studies, *G. bourquini* was reared from: *Agrotis deprivata* on *Brassica oleracea*, *Medicago sativa*, *Vicia villosa* and *Zea mays*; *Agrotis ipsilon* on *Brassica oleracea*, *Daucus carota*, *Lactuca sativa*, *Medicago sativa* and *Trifolium repens*; and *Peridroma saucia* on *Trifolium repens*, all at 2770 m elevation (San Antonio, Riobamba Province, Ecuador, June, F. Ponce, collector). It is clear that the conditions of rearing can influence the appearance of the resulting cocoon masses, as these vary from compact masses (Fig. 19) to loose piles or even individually spun woolly cocoons, depending on the available substrate. The senior author has also seen reared material of this species from various other unidentified cutworms, from *Pseudaletia unipuncta* (Haw.), as well as one unconfirmed record from *Helicoverpa zea* (Boddie).

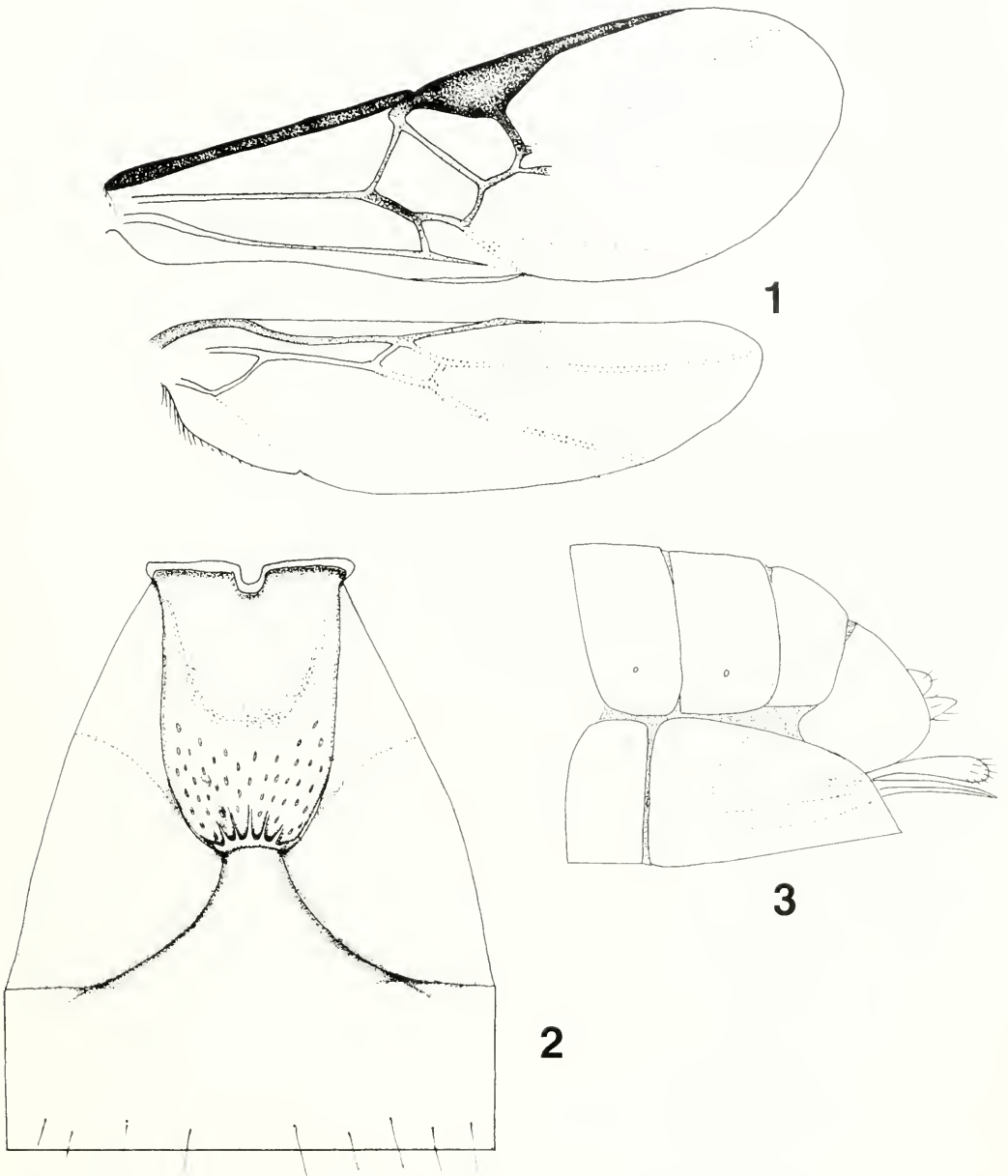

Figs. 1-3. *Glyptapanteles bourquini* (Blanchard), female. 1, Wings. 2, Anterior metasomal tergites, dorsal view. 3, Apex of metasoma, lateral view.

We are able to confirm geographical records from Argentina, Chile, Ecuador, and Uruguay. Probably it is found throughout the southern cone of South America and north into northern South America in the Andes.

*Glyptapanteles herbertii* (Ashmead)

(Figs. 4-6, 22)

*Apanteles herbertii* Ashmead 1900: 279. Holotype, Natural History Museum (NHM), London, examined. Additional reared material from USNM examined.

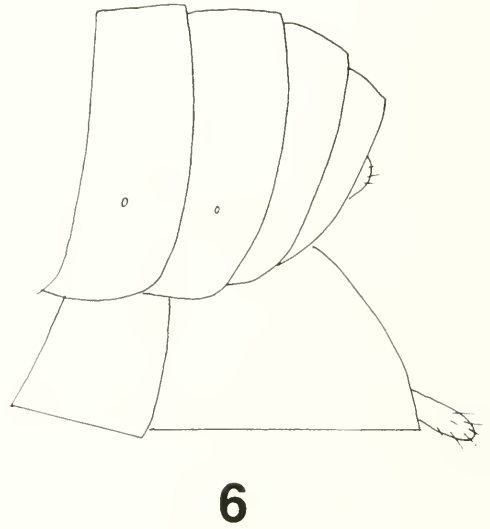
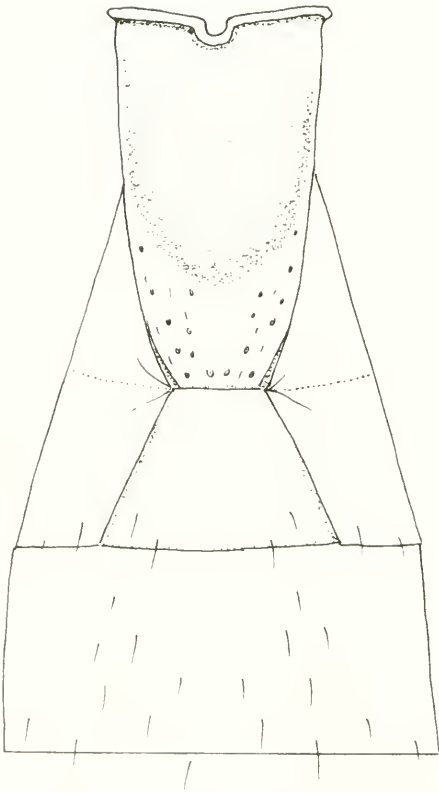
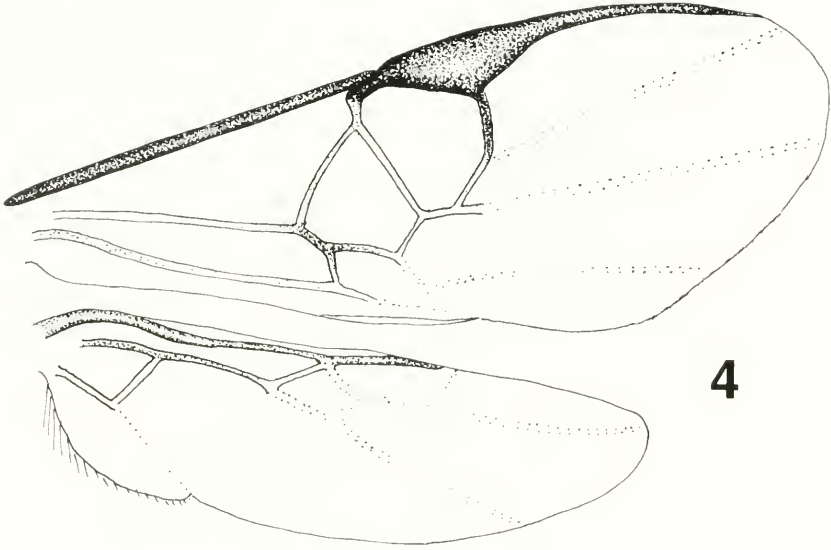

Figs. 4-6. *Glyptapanteles herbertii* (Ashmead), female. 4, Wings. 5, Anterior metasomal tergites, dorsal view. 6, Apex of metasoma, lateral view.

This species apparently belongs to a difficult complex of species that includes *G. caffreyi* (Muesebeck), *G. militaris* (Walsh), and *G. muesebecki* (Blanchard), among others. Among these, it exhibits a relatively distinctive woodpile-arrangement cocoon mass (Fig.22); other *Glyptapanteles* spin similar masses, but not typically in agricultural habitats. It seems to have often been confused with *G. caffreyi*, at least based on the material determined as the latter species in the U. S. National Museum. All of the reared material we have seen, including specimens from the neotropics, determined as *G. caffreyi* appears to represent either *G. herbertii* or *G. muesebecki*. Presumably *caffreyi* also occurs south from Arizona into at least Mexico, but probably in western dry forest areas rather than the Caribbean habitats in which *herbertii* is often found.

The host listed for *herbertii* by Shenefelt (1972) and Marsh (1979) is *Hystalea nyseus* Cram. on guava. From the material we have seen, the following appear to be more usual hosts: *Anticarsia gemmatalis* (see also Cave, 1995) and occasionally *Trichoplusia ni* and *Pseudoplusia includens* (although these latter are based on less confident identifications).

Geographically, the species appears typically circum-Caribbean, but is also found further south in South America. We have confirmed records from Argentina, Belize, Colombia, Cuba, Ecuador, Florida, Mexico, Nicaragua, Peru and Venezuela.

***Glyptapanteles militaris* (Walsh)**  
(Figs. 7–9, 20)

*Microgaster militaris* Walsh: 369. Unique holotype or lectotype not designated from original material, but at this point identity of the species has not been controversial. Examined on the basis of extensive material in USNM, Illinois Natural History Survey, as well as senior author's collection of reared material.

This species is abundant wherever corn (maize) or other gramineous crops are grown, at least in the Nearctic region, and

is recorded from a variety of noctuids on grasses, including native grasses in wild areas. The principal host in agricultural settings, at least in North America, is the armyworm, *Pseudaletia unipuncta* (Haw.).

The cocoons of this species are reported to vary in color between white to buff, and are spun loosely on or near the host caterpillar's body (fig. 20). This variation means that this species may be difficult to unequivocally separate from *G. muesebecki* and one of the new species described below, based on the cocoons. It is possible that what we and previous workers have interpreted as species differences in fact only represent geographical and/or host-induced differences within a single species. For instance, the distinctive yellow hind coxa of *militaris* may prove to be geographically and environmentally variable outside North America. For now we are treating these entities separately, hoping that whatever individual biological differences they have will become clearer with additional records. Mason (1981) provides excellent SEM photos of some features of *G. militaris*.

*Glyptapanteles militaris* is common throughout most of North America. In the neotropics it is frequently reported, although many of these records may in fact be misidentifications of the other species treated here. Probably it is at least found in the Caribbean region.

***Glyptapanteles muesebecki* (Blanchard)**  
(Figs. 10–12, 21)

*Apanteles muesebecki* Blanchard 1947: 18. Type in Blanchard collection, Buenos Aires, examined along with associated reared material now in USNM.

This species was originally referred to as *militaris* by Blanchard, (1936), then, upon receiving material determined as *militaris* by Muesebeck some years later, he decided that his South American material in fact represented a distinct species and described *muesebecki* (Blanchard 1947). The distinctions made then between the species were very fine, as they still are

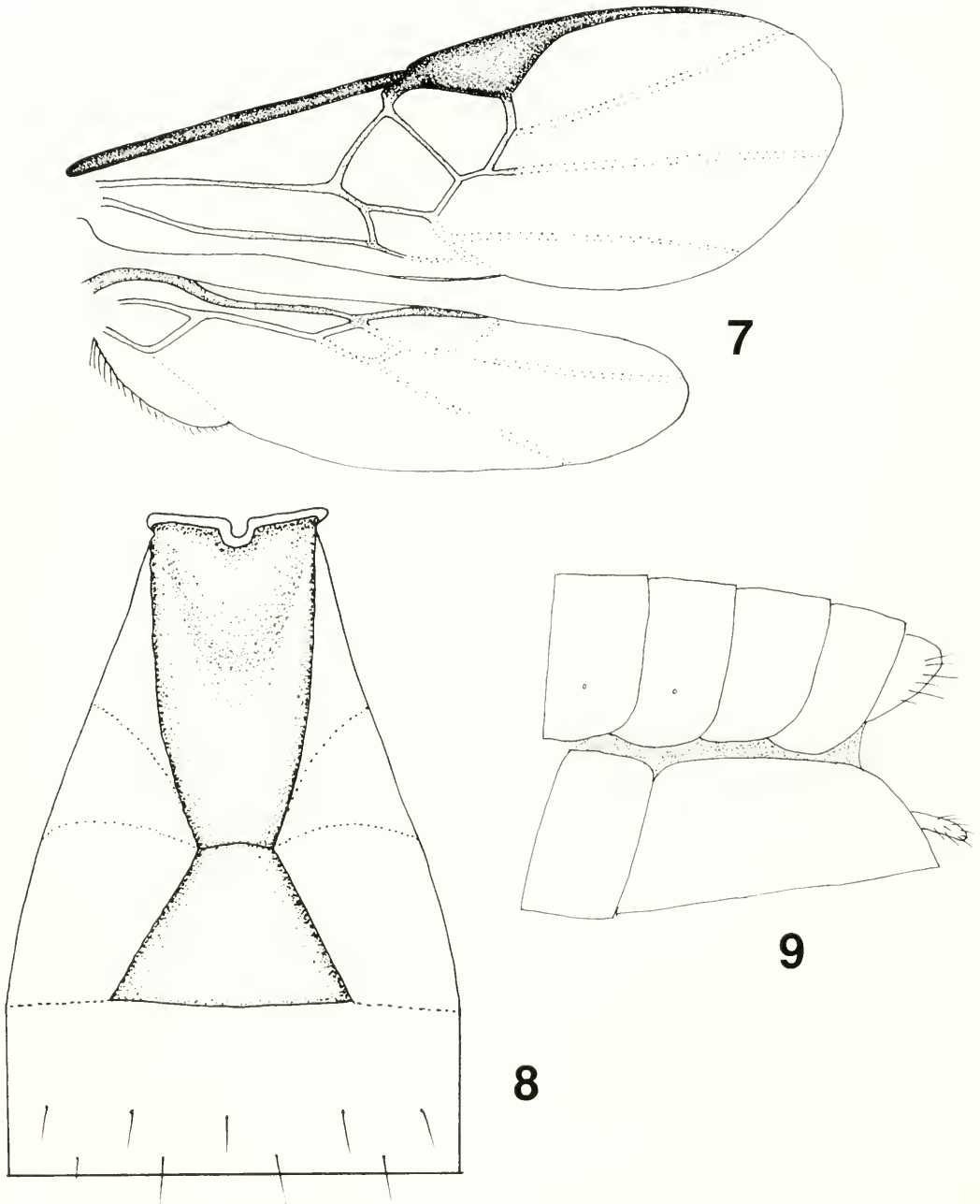

Figs. 7-9. *Glyptapanteles militaris* (Walsh), female. 7, Wings. 8, Anterior metasomal tergites, dorsal view. 9, Apex of metasoma, lateral view.

here, and the distinct species status of the two species really needs to be examined using extensive geographical sampling and genetic data. Since the examined cocoon masses of *muesbecki* are consider-

ably more orange-brown (Fig. 21) than those we have from Nearctic *militaris* (Fig. 20; some cocoon masses are more dirty whitish, even tan, than those in this photo), and there are some very slight mor-

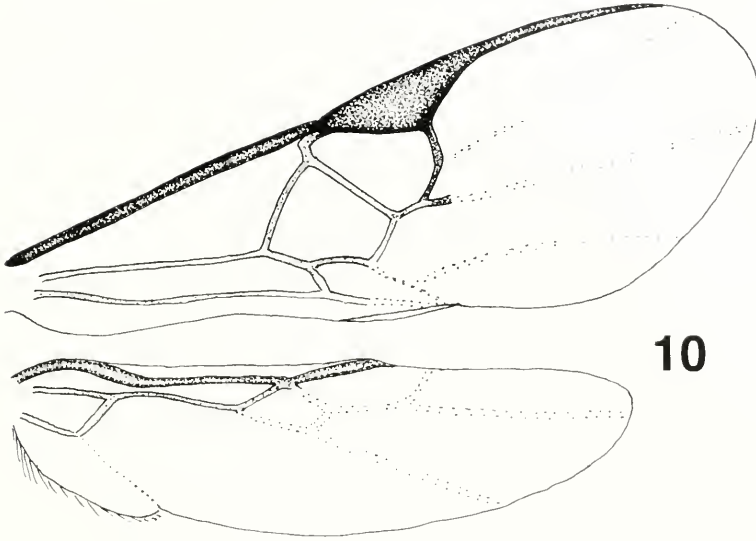

10

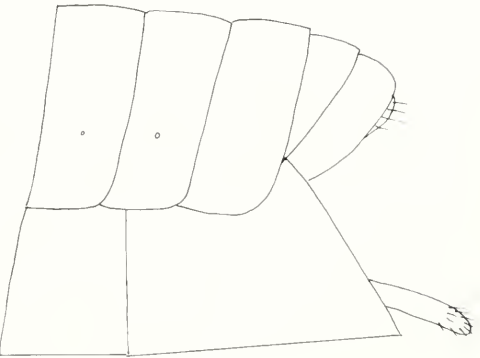
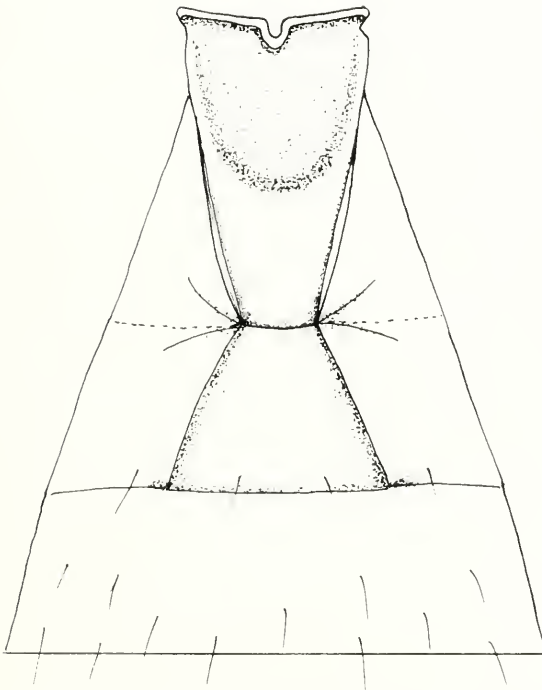

12

11

Figs. 10–12. *Glyptapanteles muesebecki* (Blanchard), female. 10, Wings. 11, Anterior metasomal tergites, dorsal view. 12, Apex of metasoma, lateral view.

phological features, mentioned in the key above, to support a distinction, we have treated *muesebecki* provisionally as a distinct species. Blanchard (1947) mentioned

the narrower first and second metasomal tergites and dark hind coxa of *muesebecki* as being distinctive; we have found the former feature to be better described as:

*muesebecki* tending to having more straight posteriorly narrowing margins of the first tergite, and tergite 2 being narrower posteriorly than in *militaris*.

To confuse matters, *G. muesebecki* is recorded from *Pseudaletia unipuncta* (Haw.), the same principal host as *G. militaris*. We have not really seen many geographical intermediates between the two, *G. militaris* being common in North America and the Caribbean region, while *G. muesebecki* is only recorded from Argentina and Paraguay.

*Glyptapanteles ecuadorius* Whitfield,  
new species  
(Figs. 13–15)

*Female*.—Body length 2.5–2.7 mm. Fore wing length 2.5–2.7 mm. *Color*. General body color black, except: lighter brown/yellowish palpi, front, middle and hind legs (except dark brown hind coxal base and apical portions of hind femur and tibia). Wings (Fig. 14) hyaline, veins including stigma generally pigmented very dark brown in pigmented portions. *Head*. Face shallowly punctate but still rather shiny, broad with inner margins of eyes not converging towards clypeus. Antenna slender, black, slightly longer than entire body length. *Mesosoma*. Mesoscutum shallowly, weakly but distinctly punctate throughout. Scutellum sculptured as mesoscutum. Metanotum with broad, nearly smooth and hairless lateral setiferous lobe. Propodeum coarsely rugulose over much of surface; nucha surrounded by very short radiating carinulae that occasionally appear to suggest posterior arms of an areola or a medial carina. *Metasoma*. Tergite I (fig. 14) smooth, relatively polished throughout, with medial depression over anterior 0.3–0.4; approximately twice as broad anteriorly as posteriorly and about 1.5× as long as broad anteriorly; lateral margins converging towards apex in a gentle curve; laterotergites light dorsally; tergite II about 2× as broad apically as long medially, but often appearing narrower in poor lighting when more strongly raised

central portion is more obvious; laterotergites much darker than those of tergite I. Hypopygium (Fig. 15) evenly sclerotized, about 3× as long medially as previous sternite; apex curving to about 70° angle at tip. Ovipositor sheath short, more slender basally than is typical in *Glyptapanteles*, slightly paddle-shaped (more strongly convex ventrally), hairy only at tip. *Legs*. Hind coxa dark brown over basal half, then becoming orangish distally. Hind tibial spurs shorter than half length of basitarsus, with inner spur slightly longer. *Wings*. Tegula dark brown. Fore wing (Fig. 13) R1 extending about 4 times as far beyond stigma as distance from its distal tip to end of 3RS fold. Stigma evenly dark brown. Veins r and 2Rs approximately of equal length, or r very slightly longer, meeting in obtuse but distinct angle.

*Male*.—Similar to female except distal antennal segments longer and more slender.

*Cocoons*.—We have not examined cocoons of this species.

*Hosts*.—*Helicoverpa zea* (Boddie) on maize (*Zea mays* L.) is the only recorded host so far.

*Material examined*.—*Holotype female*: EC-UADOR: Riobamba, Bilbao, 2000m elevation, XII-1998, F. Ponce, ex *Helicoverpa zea* on *Zea mays*. *Paratypes*: 1 male, 1 female, same data as holotype. Deposited in USNM and also (1 paratype) in the collection of Departamento de Zoología Pontificia Universidad Católica del Ecuador, Quito.

*Etymology*.—The specific epithet obviously refers to the only country (Ecuador) in which this species has been recorded so far.

*Comments*.—This species seems to be an Andean endemic. It shares with *G. bourquini* proximally slender, paddle-shaped ovipositor sheaths, and dark tegulae, but otherwise seems to share more features with the *militaris* group of species.

*Glyptapanteles agrotivorus* Whitfield,  
new species  
(Figs. 16–18, 23)

*Female*.—Body length 2.1–2.3 mm. Fore wing length 2.2–2.4 mm. *Color*. General

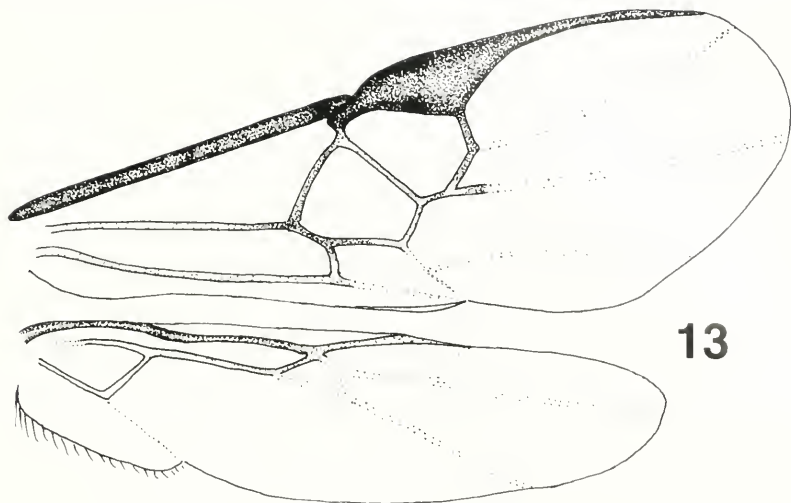

13

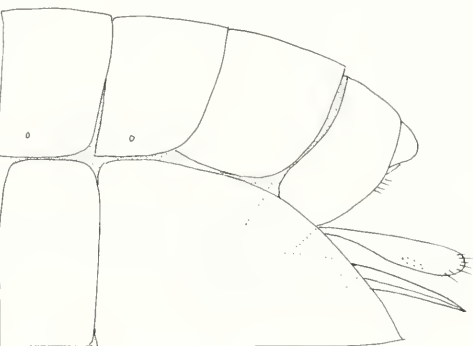
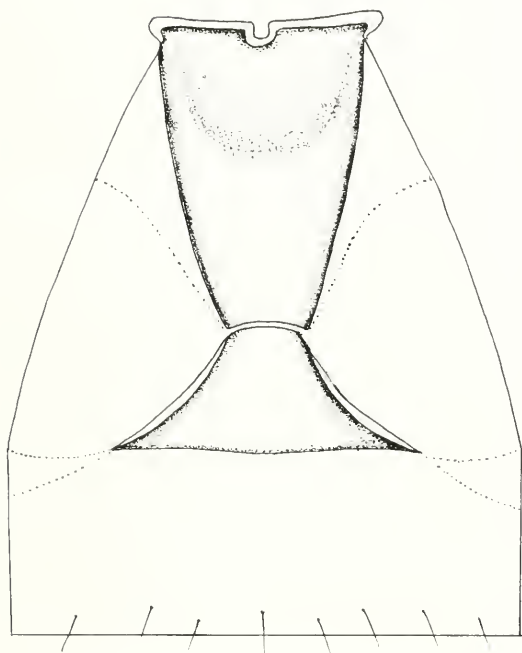

15

14

Figs. 13–15. *Glyptapanteles ecuadorius* Whitfield, n. sp., female. 13, Wings. 14, Anterior metasomal tergites, dorsal view. 15, Apex of metasoma, lateral view.

body color black, except lighter brown: fore and middle legs beyond coxae, proximal  $\frac{2}{3}$  of hind femora and tibiae. Wings (Fig. 16) hyaline, veins including stigma, when pigmented, generally pig-

mented dark brown. *Head*. Face coarsely but very shallowly punctate, slightly shiny, broad and as wide near clypeus as near antennal bases. Antenna black, slender, longer than body, even in fe-



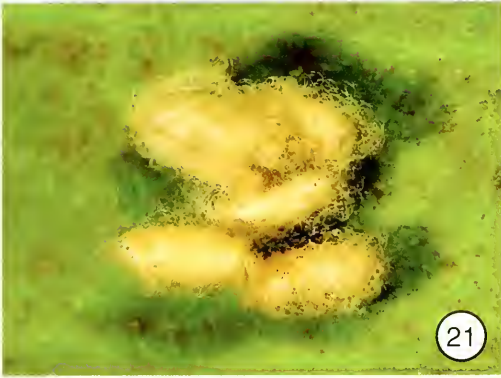

Figs. 19–24. Cocoon masses and larvae of *Glyptapanteles* spp. 19, *G. bourquini*. 20, *G. militaris*. 21, *G. muesebecki*. 22, *G. herbertii*. 23, *G. agroticorus*. 24, Larvae of *G. bourquini* emerging from host caterpillar.

*tasoma*. Tergite I (Fig. 17) essentially smooth and relatively polished throughout, with a medial depression over anterior 0.4; 1.3–1.5× as long as anteriorly broad and about twice as broad anteriorly as posteriorly, with evenly curved

lateral margins (Fig. 17 shows a first tergite that is on the short end of the spectrum of available material). Tergite II about 1.3× as broad apically as medially long, entirely smooth and with posterior edge very slightly convex medially. La-

terotergites fairly dark brown, on II more so than I. Hypopygium (Fig. 18) about 3× as long medially as preceding sternite, curving to rather truncate (80°+) tip. Ovipositor sheath short, blunt, apically hairy, projecting only slightly beyond tip of hypopygium. *Legs.* Hind coxa very finely punctate, almost completely dark brown to black except lighter at extreme apex. Hind tibial spurs shorter than half length of basitarsus, inner spur slightly longer than outer. *Wings.* Tegula dark brown. Fore wing (Fig. 16) R1 extending about 3–4 times as far beyond stigma as distance from its distal tip to end of 3RS fold. Stigma evenly very dark brown, sometimes visibly paler centrally. Fore wing veins r and 2Rs about equal in length, or r slightly longer, meeting at a sharp but obtuse angle.

*Male.*—Similar to female except apical flagellomeres longer.

*Cocoons* (Fig. 23).—White, loosely spun together with coarse silk.

*Hosts.*—*Agrotis ipsilon* (Hfn.) on *Brassica oleracea*.

*Material examined.*—*Holotype female:* EC-UADOR: Riobamba, San Antonio, 2770m elevation, 13-VII-2000, F. Ponce, ex *Agrotis ipsilon*. *Paratypes:* 1 male, 1 female, same data as holotype. Deposited in USNM and also (1 paratype) in the collection of Departamento de Zoología Pontificia Universidad Católica del Ecuador, Quito.

*Etymology.*—The specific epithet refers to the fact that this species is known to attack ("eat") cutworms of the genus *Agrotis*.

*Comments.*—This species, both in the appearance of the cocoons (Fig. 23) and in general morphology, most closely resembles *G. militaris* (Walsh). It does appear to differ in the shorter first metasomal tergite, in having a dark hind coxa, and in attacking a different host. Until a comprehensive population-level study is completed of this complex of

species, it seems best to treat this as a distinct species.

#### ACKNOWLEDGMENTS

We would like to thank Dr. David Smith (U. S. National Museum) for the loan of specimens, including holotypes, in his care, so that we could clarify the species here. Dr. Jeffrey Barnes took the close-up photographs of the cocoon masses. JBW would like to acknowledge support from the U. S. Department of Agriculture (NRI award 00-35316-9088). FP's field work was partly sponsored by the Eiselen-Foundation (Eiselen-Stiftung, Ulm, Germany). We also acknowledge support by ERPE, Riobamba.

#### LITERATURE CITED

- Angulo, A. and G. Weigert. 1975. Noctuidae (Lepidoptera) de interés económico del valle de Ica, Perú; clave para estados inmaduros. *Revista Peruana de Entomología* 18: 98–103.
- Ashmead, W. H. 1900. Report upon the Aculeate Hymenoptera of the islands of St. Vincent and Grenada, with additions to the parasitic Hymenoptera and the a list of the described Hymenoptera of the West Indies. *Transactions of the Royal Entomological Society of London*, 1900: 207–367.
- Blanchard, E. E. 1936. Microgastrinos argentinos, nuevos y poco conocidos. Segunda parte. *Physis, Revista de la Sociedad Argentina de Ciencias Naturales* 12 (43): 137–152.
- Blanchard, E. E. 1947. Descripciones y anotaciones de microgastrinos Argentinos (Hymenoptera). *Arthropoda (Buenos Aires)* 1: 6–22.
- Cave, R. D. 1995. *Manual para el Reconocimiento de Parasitoides de Plagas Agrícolas en América Central*. Zamorano, Tegulcigalpa, Honduras. 202 pp.
- Marsh, P. M. 1979. Family Braconidae. Pp. 144–295 in: Krombein, K.V., Hurd, P. D., Jr., Smith, D. R. & B.D. Burks, eds., *Catalog of Hymenoptera in America North of Mexico. Vol 1. Symphyta and Apocrita (Parasitica)*. Smithsonian Institution Press, Washington, D.C.
- Mason, W. R. M. 1981. The polyphyletic nature of *Apanteles* Foerster (Hymenoptera: Braconidae): a phylogeny and reclassification of Microgastrinae. *Memoirs of the Entomological Society of Canada* 115: 1–147.
- Muesebeck, C. F. W. 1920. A revision of the North American species of the ichneumon-flies belonging to the genus *Apanteles*. *Proceedings of the United States National Museum* 58: 483–576.
- Sharkey, M. J. and R. A. Wharton. 1997. Morphology and terminology. Chapter 2, pp. 19–37 in: Wharton, R. A., P. M. Marsh, and M. J. Sharkey, eds. *Identification Manual to the New World Genera of the Family Braconidae (Hymenoptera)*. International

- Society of Hymenopterists Special Publication 1. 439 pp.
- Shenefelt, R. D. 1972. Braconidae 4, Microgasterinae, *Apanteles*. Pars 7, pp. 429–668 in: Vecht, J. van der and R. D. Shenefelt, eds., *Hymenopterorum Catalogus (Nova Editio)*. W. Junk, 's Gravenhage.
- Whitfield, J. B. 1997. Subfamily Microgastrinae. Chapter 29, pp. 333–364 in: Wharton, R. A., P. M. Marsh, and M. J. Sharkey, eds. *Identification Manual to the New World Genera of the Family Braconidae (Hymenoptera)*. International Society of Hymenopterists Special Publication 1. 439 pp.







## INSTRUCTIONS FOR AUTHORS

**General Policy.** The *Journal of Hymenoptera Research* invites papers of high scientific quality reporting comprehensive research on all aspects of Hymenoptera, including biology, behavior, ecology, systematics, taxonomy, genetics, and morphology. Taxonomic papers describing single species are unlikely to be accepted unless a strong case is evident, such as importance in economic entomology or with concurrent biology or ecology. Manuscript length generally should not exceed 50 typed pages; however, no upper limit on length has been set for papers of exceptional quality and importance, including taxonomic monographs at generic or higher level.

All papers will be reviewed by at least two referees. The referees will be chosen by the appropriate subject editor. However, it would be helpful if authors would submit the names of two persons who are competent to review the manuscript.

The language of publication is English. Summaries in other languages are acceptable.

**The deadline for receipt of manuscripts is 1 October (for the April issue) and 1 April (for the October issue).**

**Format and Preparation.** Three copies of each manuscript, including copies of illustrations, should be submitted on letter size or A4 paper, double spaced, with at least 25 mm margins on all sides. On the upper left of the title page give name, address and telephone and fax numbers of the author to whom all correspondence is to be sent.

The paper should have a concise and informative title, followed by the names and addresses of all authors. The sequence of material should be: title, author(s), abstract, text, acknowledgments, literature cited, appendix, figure legends, figure copies (each numbered and identified), tables (each numbered and with heading). Each of the following should start a new page: (1) title page, (2) abstract, (3) text, (4) literature cited, (5) figure legends, (6) footnotes.

Following acceptance of the manuscript, the author should provide the editor with one copy of the manuscript accompanied by a copy on diskette using DD, double sided computer diskettes—IBM compatible MS DOS 5.25 inch or IBM and Macintosh 3.5 inch diskettes. (Authors who do not have access to a computer should submit three copies of the manuscript.) The paper may be submitted in most PC and Mac word processor programs such as Microsoft Word, FullWrite Professional, WordPerfect, WriteNow, Nisus, MacWrite, or MacWrite II. If possible, all words that must be italicized should be done so, not underscored. Tables may be formatted in a spread sheet program such as MS Works or MS Excel. Text should be double-spaced typing, with 25 mm left and right margins. Tables should be put in a separate file. Diskettes should be accompanied by the name of the software program used (e.g., WordPerfect, Microsoft Word). Authors should keep backup copies of all material sent to the Editor. The Society cannot be responsible for diskettes or text mislaid or destroyed in transit or during editing.

Illustrations should be planned for reduction to the dimension of the printed page (14 × 20.5 cm, column width 6.7 cm) and allow room for legends at the top and bottom. Do not make plates larger than 14 × 18 in. (35.5 × 46 cm). Individual figures should be mounted on a suitable drawing board or similar heavy stock. Photographs should be trimmed, grouped together and abutted when mounted. Figure numbers should be on the plate, and it is strongly recommended that names be included after the numbers (e.g., Fig. 2, *texanus*). Include title, author(s) and address(es), and illustration numbers on back of each plate. Original figures need not be sent until requested by the editor, usually after the manuscript has been accepted. Reference to figures/tables in the text should be in the style "(Fig. 1)" "(Table 1)". Measurements should be in the metric system.

All papers must conform to the *International Code of Zoological Nomenclature*. The first mention of a plant or animal should include the full scientific name including the authority. Genus names should not be abbreviated at the beginning of a sentence. In taxonomic papers type specimens must be clearly designated, type depositories must be clearly indicated, and new taxa must be clearly differentiated from existing taxa by means of keys or differential diagnoses. Authors are required to deposit all type material in internationally recognized institutions (not private collections). Voucher specimens should be designated for specimens used in behavioral or autecological studies, and they should be deposited similarly.

Acceptance of taxonomic papers will not require use of cladistic methods; however, authors using them will be expected to specify the phylogenetic program used (if any), including discussion of program options used. A data matrix should be provided if the subject is complex. Cladograms must be hung with characters and these should include descriptors (not numbers alone) when feasible. The number of parsimonious cladograms generated should be stated and reasons given for the one adopted. Lengths and consistency indices should be provided. Adequate discussions should be given for characters, plesiomorphic conditions, and distributions of characters among outgroups when problematical.

References in the text should be (Smith 1999), without a comma, or Smith (1999). Two articles by a single author should be (Smith 1999a, 1999b) or Smith (1999a, 1999b). For multiple authors, use the word "and," not the symbol "&" (Smith and Jones 1999). For papers in press, use "in press," not the expected publication date. The Literature Cited section should include all papers referred to in the paper. Journal names should be spelled out completely and in italics.

**Charges.** Publication charges are \$10.00 per printed page. At least one author of the paper must be a member of the International Society of Hymenopterists. Reprints are charged to the author and must be ordered when returning the proofs; there are no free reprints. Author's corrections and changes in proof are also charged to the author. Color plates will be billed at full cost to the author.

All manuscripts and correspondence should be sent to:

Dr. E. Eric Grissell  
Systematic Entomology Laboratory, USDA  
% National Museum of Natural History  
10th and Constitution NW  
Washington, DC 20560-0168

Phone: (202) 382-1781 Fax: (202) 786-9422 E-mail: egrissel@sel.barc.usda.gov



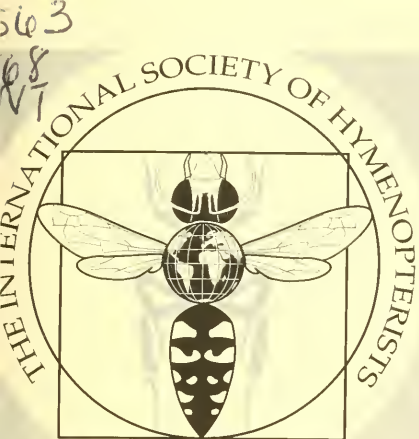

# Journal of Hymenoptera Research



**Volume 11, Number 2**

**October 2002**

ISSN #1070-9428

## CONTENTS

BURKS, R. A. and J. M. HERATY. Morphometric analysis of four species of <i>Trichogramma</i> Westwood (Hymenoptera: Trichogrammatidae) attacking codling moth and other tortricid pests in North America .....	167
CÔNSOLI, F. L. and S. B. VINSON. Larval development and feeding behavior of the wing dimorphics of <i>Melittobia digitata</i> Dahms (Hymenoptera: Eulophidae) .....	188
EVANS, G. A. and C. A. SERRA. Parasitoids associated with whiteflies (Homoptera: Aleyrodidae) in Hispaniola and descriptions of two new species of <i>Encarsia</i> Förster (Hymenoptera: Aphelinidae) .....	197
GATES, M. W., J. M. HERATY, M. E. SCHAUFF, D. L. WAGNER, J. B. WHITFIELD, and D. B. WAHL. Survey of the parasitic Hymenoptera on leafminers in California ..	213
GRISSELL, E. E. and S. A. CAMERON. A new <i>Leucospis</i> Fabricius (Hymenoptera: Leucospidae), the first reported gregarious species .....	271
GRISSELL, E. E. and C. A. DESJARDINS. A revision of <i>Bootania</i> Dalla Torre and recognition of <i>Macrodasycceras</i> Kamijo (Hymenoptera: Torymidae) .....	279
MITCHELL, A. and D. J. BROTHERS. Phylogeny of the genera of Ticoplinae (Hymenoptera: Mutillidae) .....	312
PHILLIPS, C. B. Observations of oviposition behavior of <i>Microctonus hyperodae</i> Loan and <i>M. aethiopoidea</i> Loan (Hymenoptera: Braconidae: Euphorinae) .....	326
PITTS, J. P. and J. V. McHUGH. Review of <i>Acrophotopsis</i> Schuster (Hymenoptera: Mutillidae: Sphaerophthalminae), with description of a new species from Baja California .....	338
TAVARES, M. G., L. A. O. CAMPOS, E. G. BARROS, and M. T. V. A. OLIVEIRA. RAPD linkage map of <i>Melipona quadrifasciata anthidioides</i> Lepelletier (Hymenoptera: Apidae: Meliponini) .....	350

(Continued on back cover)

# INTERNATIONAL SOCIETY OF HYMENOPTERISTS

Organized 1982; Incorporated 1991

---

## OFFICERS FOR 2002

Lynn Kimsey, *President*  
Denis Brothers, *President-Elect*  
James B. Woolley, *Secretary*  
John T. Huber, *Treasurer*  
E. Eric Grissell, *Editor*

---

## Subject Editors

SYMPHYTA AND PARASITICA  
*Biology:* Mark Shaw  
*Systematics:* Donald Quicke

ACULEATA  
*Biology:* Sydney Cameron  
*Systematics:* Wojciech Pulawski

---

All correspondence concerning Society business should be mailed to the appropriate officer at the following addresses: President, Bohart Museum of Entomology, Department of Entomology, University of California, Davis, CA 95616; Secretary, Department of Entomology, Texas A&M University, College Station, Texas 77843; Treasurer, Eastern Cereal & Oilseed Research Centre, Agriculture Canada, K. W. Neatby Building, Ottawa, Ontario, Canada K1A 0C6; Editor, Systematic Entomology Laboratory, USDA, P.O. Box 37012, c/o National Museum of Natural History CE 520, MRC 168, Washington, D.C. 20013-7012.

**Membership.** Members shall be persons who have demonstrated interest in the science of entomology. Annual dues for members are US\$40.00 per year (US\$35.00 if paid before 1 February), payable to The International Society of Hymenopterists. Requests for membership should be sent to the Treasurer (address above). Information on membership and other details of the Society may be found on the World Wide Web at <http://IRIS.biosci.ohio-state.edu/ish>.

**Journal.** The *Journal of Hymenoptera Research* is published twice a year by the International Society of Hymenopterists, c/o Department of Entomology, Smithsonian Institution, Washington, D.C. 20560-0168, U.S.A. Members in good standing receive the *Journal*. Nonmember subscriptions are \$60.00 (U.S. currency) per year.

The Society does not exchange its publications for those of other societies.

**Please see inside back cover of this issue for information regarding preparation of manuscripts.**

---

## Statement of Ownership

Title of Publication: Journal of Hymenoptera Research.

Frequency of Issue: Twice a year.

Location of Office of Publication, Business Office of Publisher and Owner: International Society of Hymenopterists, c/o Department of Entomology, Smithsonian Institution, 10th and Constitution NW, Washington, D.C. 20560-0168, U.S.A.

Editor: E. Eric Grissell, Systematic Entomology Laboratory, USDA, c/o National Museum of Natural History, 10th and Constitution NW, Washington, D.C. 20560-0168. U.S.A.

Managing Editor and Known Bondholders or other Security Holders: none.

---

This issue was mailed 8 October 2002

## Morphometric Analysis of Four Species of *Trichogramma* Westwood (Hymenoptera: Trichogrammatidae) Attacking Codling Moth and other Tortricid Pests in North America

ROGER A. BURKS AND JOHN M. HERATY

Department of Entomology, University of California, Riverside, CA 92521 USA,  
email: rogerb@citrus.ucr.edu

---

*Abstract.*—Four species of *Trichogramma* Westwood are distinguished with overlap using morphometric analyses of 496 specimens with 27 measurements of males, 26 of females. The cryptic species of the *T. minutum* complex, *T. minutum* Riley and *T. platneri* Nagarkatti, are distinguished morphologically for the first time using canonical variate analysis. Intermediacy between *T. californicum* Nagaraja and Nagarkatti and the *T. minutum* complex is examined, with reference to other sources of variation. Males of the four species could be identified using a linear discriminant function with 0–3.9% error when applied to specimens used in developing the function, with *T. minutum* and *T. californicum* identified with error rates of 10.3–12.8% using novel resampled data; females could be separated with error rates of 3.3–18.9% using only the calibration specimens, with *T. minutum* and *T. californicum* identified with an error rate of 27.2–29.4% using novel resampled data. An identification key to males of the four species is provided that uses a combination of morphological characters and the discriminant functions. Implications of these results for quality control of mass releases and the identification of *Trichogramma* are discussed.

---

*Trichogramma* Westwood is the most important genus of egg parasitoids attacking Tortricidae in tree crops (Mills and Carl 1991). They are routinely released in augmentative biological control programs, although with mixed success (Falcon and Huber 1991, Smith 1996). By far the most common wasps used in the augmentative control of these pests in North America are the two species that comprise the *T. minutum* species complex: *T. minutum* Riley and *T. platneri* Nagarkatti. These species are also the dominant native egg parasitoids of tortricid pests in fruit orchards (Stouthamer et al. 2000b). At least nine other native species of *Trichogramma* attack these pests, but these appear to be much less common (Pinto et al. 2002).

The *T. minutum* species complex presents one of the most acute taxonomic problems in the genus, because its two species have been considered indistinguishable morphologically (Nagarkatti

1975, Pinto et al. 1991). Their separation is based on mutual reproductive incompatibility, differences in certain allozymic loci as determined through electrophoresis (Pinto et al. 1992) and geography, with *T. minutum* found primarily east of the Rocky Mountains and *T. platneri* west of the Rockies. The two species mate readily in laboratory settings, but hybrid females die in the embryonic stage (Stouthamer et al. 2000b). Because both species are commonly mass released against Lepidopteran pests (Kuhlmann and Mills 1999), these findings have serious implications for augmentative control programs, as it is clear that unless high rates of sib-mating or intraspecific encounters between individuals of different sexes occur, there can be negative reproductive interactions when releases result in mixed populations of the two species. Sib-mating should be particularly low for parasitoids of small, isolated eggs, and it has been estimated

that levels of sib-mating for the *T. minutum* complex on codling moth, *Cydia pomonella* (Linnaeus), and oriental fruit moth, *Grapholita molesta* (Busck), on tree crops will not exceed 63%, resulting in considerable opportunity for interspecific mating when both species are present (Stouthamer et al. 2000b). For these reasons, the accurate identification of insectary cultures and field populations is imperative to maximize the benefit of control programs involving members of the *T. minutum* complex.

Morphological identification of most species of *Trichogramma* is difficult due to their small size and overlap of potentially diagnostic characters (Pinto 1999). Almost all of the diagnostic characters for *Trichogramma* are found on either the genitalia or antennal flagellum of males. Female *Trichogramma* have been considered unidentifiable morphologically except when the number of possible diagnoses can be narrowed down by associating them with co-occurring males of known identity. This is a major problem considering that females are usually more common than males, and males are absent in thelytokous populations. Non-morphological identification methods are available, including reproductive compatibility with known reference cultures and diagnostic allozymic profiles (Pinto et al. 1991, 1992), but these methods require living and specially preserved dead specimens, respectively, and usually the establishment of cultures to provide enough material for study. The ITS2 genetic region has been investigated as a means of separating *T. minutum* and *T. platneri*, but it is identical for the two species (Stouthamer et al. 2000a). These difficulties, along with the possible presence of other species in release zones, complicate augmentative biological control efforts by requiring that both pre- and post-release assessment be dependent upon processes of specimen identification that are often not practical.

Using minor morphological differences,

other species of *Trichogramma* associated with tortricid orchard pests can be recognized from members of the *T. minutum* complex (Pinto 1999), but these differences are confounded by an incomplete knowledge of intraspecific variation and apparent intermediacy. Problems of morphological intermediacy are especially apparent in the distinction between *T. platneri* and *T. californicum* Nagaraja and Nagarkatti, two species syntopic in western North America (Pinto 1999).

*Trichogramma californicum* was described from specimens reared from eggs of the Douglas fir tussock moth, *Orgyia pseudotsugata* (McDunnogh), collected from Alturas, Modoc County, in northeastern California (Nagaraja and Nagarkatti 1973). It was distinguished primarily by morphological features, but also because it was reproductively incompatible with laboratory cultures of other species of *Trichogramma* available at the time. *Trichogramma californicum* and *T. minutum* were distinguished by color, length and shape of flagelliform antennal setae, and ovipositor to hind tibia length ratio. The morphological distinctness of *T. californicum* was reassessed in a recent revision of the North American species of *Trichogramma* (Pinto 1999). No successful hybridization was found between the then available cultures of *T. californicum* and four other species: *T. exiguum* Pinto and Platner, *T. funestum* Pinto and Oatman, *T. interius* Pinto, and the Cow Head Lake (PCHL, Modoc Co., CA) culture of *T. platneri*, but it was noted that some crosses that should have been done had not yet been conducted (Pinto 1999). Recently, three cultures of *T. californicum*, CAAD, CASB, and CAYK (Table 1), were shown to be different from *T. minutum*, *T. platneri*, and two cultures of *T. exiguum* (EXHN, EXSL) at three loci using allozymic electrophoresis (Burks and Pinto 2002). High allozymic variability and low reproductive compatibility among the three cultures of *T. californicum* provided little evidence of their conspecificity, but

there was not enough evidence to exclude any of the three cultures from the rest of the species.

*Trichogramma exiguum* was described from eastern North America (Pinto et al. 1978). *Trichogramma exiguum* and *T. californicum* have similar male genitalic structure, and the flagelliform setae are relatively short and abruptly tapered in both (Pinto 1999). *Trichogramma exiguum* is also similar morphologically to the *T. minutum* complex, and is most likely to be confused with *T. minutum* because the two species are sympatric in eastern North America and are found on the same hosts, including codling moth and oriental fruit moth.

The purpose of this study is to investigate the potential of quantitative morphometric analysis to separate both males and females of the *T. minutum* complex, *T. californicum*, and *T. exiguum*.

#### MATERIALS AND METHODS

*Specimens.*—A total of 496 specimens were measured in this study, 231 males and 265 females, from 47 different laboratory-reared cultures (Table 1). Each culture originated from a single mated female that emerged from a field-collected host egg. Cultures were maintained in the laboratory at 21–27° C on irradiated *Trichoplusia ni* (Hübner) eggs. Selection of specimens was conducted on a culture by culture basis, with each included culture having been identified through complete direct or indirect reproductive compatibility with a reference culture (MCVA for *T. minutum*, PRV1 for *T. platneri*, CAAD for *T. californicum*, and EXSL for *T. exiguum*) and by morphological characteristics reported in Pinto (1999). Cultures for which reproductive compatibility data were not available were used only in posterior tests of the discriminant functions (indicated by asterisk in Table 1). All specimens were slide-mounted dorsoventrally in Canada Balsam (458 specimens) or Hoyer's medium (38 specimens) using uniform methodology (Platner et al. 1999). Specimens

are stored in the University of California, Riverside, Department of Entomology Research Museum, each identified with an individual reference code UCRC ENT 43346–43841 and the voucher code RB1. Only specimens for which all measurements could be made unambiguously were included.

*Characters.*—A total of 27 morphological features for males and 26 for females were measured (Table 2, Fig. 1). All terms are the same as in Pinto (1999). Characters were selected on the basis of perceived taxonomic potential and presence of consistent landmarks (*sensu* Bookstein et al. 1985). Features that could not be accurately measured as a straight line were not used, with the exception of the longest flagelliform antennal seta length in males (lfs), which was represented as the sum of two measurements extending from the point of greatest curvature of the seta to its tip and base. We regard all of the landmarks to be readily placed, although perhaps the features of the antenna in both sexes could be the most easily confused. For clarity, these are illustrated in greater detail (Fig. 2). For cla, landmark 24 is the most apical point of the club, not counting the multiporus plate or basiconic peg sensilla, which may extend beyond the claval apex. In males, landmarks 25, 26, and 27 are based upon an earlier description of flagellar regions in male *Trichogramma* by Vincent and Goodpasture (1986), used again by Pinto (1999). The limits of each flagellomere are marked by distinct ventral constrictions (Fig. 2) that are proposed as homologous to separations between segments in species with more distinct flagellar segments (such as in the subgenera *Vanlisus* Pinto and *Trichogrammanza* Carver). In females, inclusion of measurements of the funicular segments (characters lfa-lfd and wfa-wfd) achieved a 2% reduction of the overall error in linear discriminant reclassification. However, these measurements were excluded from the final analysis because these landmark points were

Table 1. Collection details, code, and number of specimens studied for each culture. Unmarked cultures were included in the calibration dataset. Cultures marked by an asterisk (\*) were included in the test dataset only.

Collection locality	Code	Collection date	# Of specimens	
			Male	Female
<i>T. californicum</i>	—	—	42	36
CA: Adin,	CAAD	24.vii.1992	10	10
CA: Alturas (types)*	CAAL	20.vi.1967	1	1
*CA: Garberville	CAGB	4.vi.1987	5	2
CA: Magee Mtn.	CAMM	12.vii.1992	2	3
CA: Sage*	CASG	11.iii.1980	2	0
CA: San Bernardino Mtns	CASB	12.viii.1997	10	10
ID: Greenleaf*	CAGL	13.viii.1999	2	0
WA: Yakima	CAYK	3-7.vii.1997	10	10
<i>T. exiguum</i>	—	—	19	15
AL: Selma	EXSL	5.x.1972	9	5
NC: Hendersonville	EXHN	15.viii.1997	10	10
<i>T. minutum</i>	—	—	102	122
CA: Chula Vista	MCVA	3.x.1973	10	10
CO: Colbran	MCLB	14.viii.1997	5	1
CO: Fruita	MFRU	13.viii.1997	4	6
ID: Bonner's Ferry	MBFY	27.viii.1997	3	7
KY: Rich Hill	MRHH	8.viii.1998	3	6
MD: Smithsburg	MSMT	7.viii.1998	5	5
ME: Winterville	MWTV	24.ix.1980	10	2
MN: southeastern	MSMN	2.viii.1992	5	3
MN: St. Paul	MSPL	21.i.1986	1	8
MO: Bigspring	MBGS	15.ix.1970	5	8
MO: Kirkwood	MKKW	24.ix.1970	0	4
NC: Hendersonville	MHND	26.viii.1997	5	7
NM: Albuquerque	MABQ	1.ix.1987	3	5
ON: Dryden	MDRY	25.vii.1990	5	7
TN: Monteagle	MONT	28.vi.1986	3	2
UT: Fairfield	MIFD	12.viii.1997	5	6
UT: Kanab	MKNB	7-10.viii.1997	3	9
UT: Springdale	MSGD	7.viii.1997	4	2
UT: Tropic	MTRP	8.viii.1997	5	8
WA: Mead	MEAD	21.viii.1997	9	6
WA: Wenatchee	MWEN	25.viii.1997	5	4
WI: Madison	MMDS	28-29.vii.1998	4	6
<i>T. platneri</i>	—	—	68	92
BC: Summerland	PSUM	1.viii.1997	4	6
CA: Boulder Creek	PBCK	11-12.ix.1997	5	6
CA: Cow Head Lake	PCHL	22.vii.1992	5	5
CA: El Toro	PELT	18.ii.1983	1	4
CA: Garberville	PGRB	5.vi.1987	5	3
CA: James Reserve	PJRV	7.vi.1985	5	8
CA: Julian	PJUL	21-23.vii.1998	1	4
CA: Newcastle	PNWC	6.ix.1990	5	1
CA: Riverside	PRVI	15.vii.1971	10	10
CA: Winters	PWTS	1.vii.1981	5	10
MT: Libby	PLIB	27.viii.1997	5	9
OR: Pendleton	PPND	24.viii.1997	5	10
WA: Colville	PCLV	22.viii.1997	5	5
WA: Granger	PGRN	24.viii.1987	5	5
WA: Walla Walla	PWWL	23.viii.1997	3	6
Total all species	—	—	231	265

Table 2. Characters measured and their descriptions. Landmarks refer to points in Figure 1.

Code	Sex	Landmarks	Description
<b>Genitalia</b>			
aed	M	2-13	Length of aedeagus from apodemes to tip (tips of both apodemes usually not equidistant from tip of aedeagus, so their position was averaged by drawing a line between tips apodemes and measuring from middle of that line)
lge	M	1-13	Length of genital capsule (apical point determined by drawing line between tips of parameres and measuring from middle of that line)
wgc	M	3-4	Greatest width of genital capsule (without landmarks)
gcj	M	5-6	Width of genital capsule at base of dorsal lamina
apd	M	10-12	Apical distance (apical coordinate determined as with lge)
lda	M	1-9	Length of dorsal aperture
ldl	M	9-11	Length of posterior extension of dorsal lamina
wdl	M	7-8	Width of dorsal lamina at the widest point of its shoulders
ivp	M	14-15	Length of intervolsellar process
ovp	F	16-20	Length of ovipositor sheaths from base of 1st and 2nd valvulae (= 1st and 2nd gonapophyses) to tip of 3rd valvula (= gonoplac)
svf	F	17-18	Length of 2nd valvifer (= 2nd gonocoxa) from base to medial corner of 3rd valvula
dtv	F	19-20	Lateral length of 3rd valvula from base to tip
ltv	F	18-20	Medial length of 3rd valvula from base to tip
wtv	F	18-19	Width of 3rd valvula base from medial corner to lateral corner
<b>Antenna</b>			
cla	M	24-25	Ventral length of 4th flagellar region
clb	M	25-26	Ventral length of 3rd flagellar region
clc	M	26-27	Ventral length of 2nd flagellar region
cld	M	27-28	Ventral length of 1st flagellar region
lcv	F	29-30	Maximum length of club
lfa	F	32-34	Ventral length of 2nd funicular segment
lfb	F	31-33	Dorsal length of 2nd funicular segment
lfc	F	36-38	Ventral length of 1st funicular segment
lfd	F	35-37	Dorsal length of 1st funicular segment
lfs	M	21-22-23	Longest flagelliform antennal seta length (flagelliform setae are almost always strongly arched, so measurements were taken by combining the lengths of lines projecting from the point of greatest curvature to the tip and base of the seta, respectively)
sca	M/F	39-40	Dorsal length of scape, from dorso-apical corner to dorso-apical corner of radicle
wfa	F	31-32	Apical width of 2nd funicular segment
wfb	F	33-34	Basal width of 2nd funicular segment
wfc	F	35-36	Apical width of 1st funicular segment
wfd	F	37-38	Basal width of 1st funicular segment
<b>Legs</b>			
lmb	M/F	41-42	Dorsal length of metatibia
mta	M/F	43-44	Dorsal length of basal metatarsal segment
mtb	M/F	45-46	Dorsal length of middle metatarsal segment
mtc	M/F	47-48	Dorsal length of apical metatarsal segment
spa	M/F	49-50	Length of metatibial spur, from socket to tip
spb	M/F	51-52	Length of mesotibial spur, from socket to tip
<b>Wings</b>			
lwg	M/F	57-58	Length of fore wing from its base immediately distal to humeral plate to where the M setal track reaches the wing margin
wwg	M/F	59-60	Width of fore wing from end of 3rd setal track to end of posterior-most setal track
lsv	M/F	53-54	Length of stigmal vein (the base of the stigmal vein cannot be determined using landmarks, and the pigmented apex of the stigmal vein could not always be determined with satisfactory accuracy, so the sockets of two consistently locatable setae were used as landmarks)
wsv	M/F	55-56	Width of stigma vein at its narrowest point, no landmarks
lfl	M/F	61-62	Length of longest marginal fringe seta of fore wing
lhm	M/F	63-64	Length of longest marginal fringe seta of hind wing

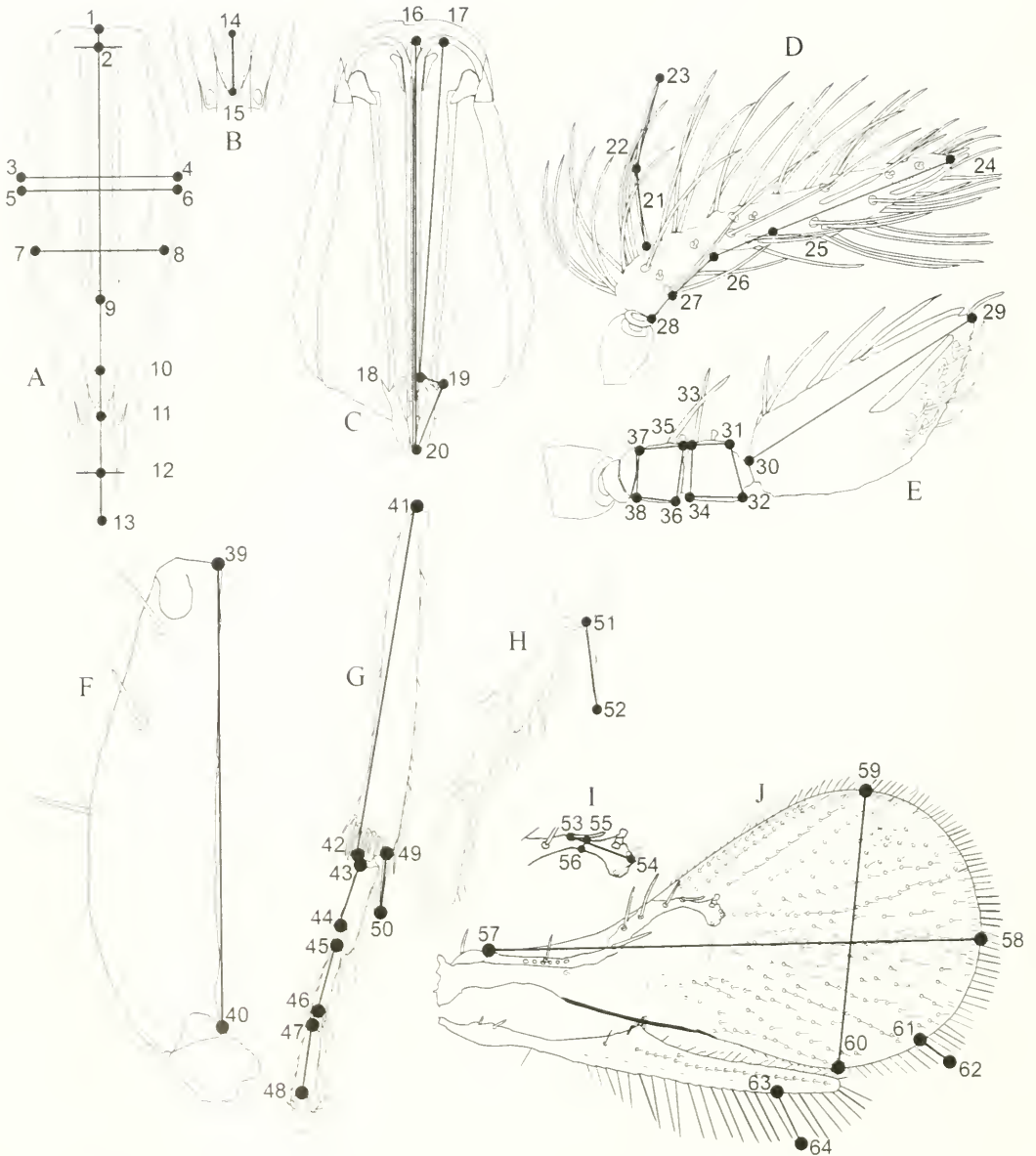

Fig. 1. Measurements for males and females of *Trichogramma*; numbers represent character landmarks defined in Table 2. A, Male genitalia. B, Intervolsellar process. C, Ovipositor. D, Male antenna. E, Female antenna. F, Scape. G, Metatibia and metatarsus. H, Mesotarsus. I, Stigmal vein. J, Wings.

difficult to position on the rounded edges of the segments, making it difficult to define them in an objective manner.

Landmark points could be readily observed in all of the specimens used for this analysis, and admittedly only good quality mounts can be scored for all of the rel-

evant landmarks. The identification key provided in the discussion will be useful for most specimens, but in cases that require definitive results, a set of well-mounted specimens is necessary. This is achievable using the methods provided by Platner et al. (1999), which made possible

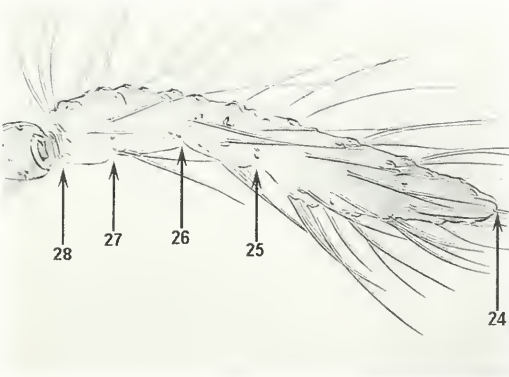

Fig. 2. Photograph of slide-mounted antenna of male *Trichogramma platneri* (PLIB) with landmarks indicated; numbers represent points defined in Table 2.

the use of nearly 500 uniformly positioned specimens for this study.

**Measurements.**—Specimens were measured using a Leica DMRB microscope through a Sony DXC-107 videochip camera using the same methods described in Heraty and Polaszek (2000). The computer program Morphosys (Meachum and Duncan 1987) was used to measure pixel distances between on-screen point coordinates and convert them to millimeter distances. Landmarks were gathered at magnifications of 200–640 $\times$ . Linear measurements were analyzed using SAS release 8.00 software.

**Statistical analyses.**—Unless stated otherwise, all analyses were conducted on two calibration datasets, one for each sex (Table 1). Using the same specimen data, subset analyses comparing only a pair of species, or comparing the *T. minutum* complex as a whole with *T. californicum* or *T. exiguum*, were performed using principal component analysis, using the specimens of those species contained in the calibration datasets. These data sets are available in SAS format files from the corresponding author upon request.

Males and females of the four species were analyzed separately in an 'all species' calibration dataset (ASD) using 19 variables, although not all variables were

shared in each dataset (Table 6). Males were studied further in four subset analyses that focused on comparisons of *T. minutum* with *T. platneri*, *T. californicum* with *T. exiguum*, and the *T. minutum* complex with *T. californicum* and *T. exiguum*. In each case the morphometric variables were a subset of the variables used in the ASD of males (Table 6). Females of *T. minutum* and *T. platneri* were analyzed separately using a subset of 12 variables from the ASD of females. Variables for each analysis were chosen using stepwise discriminant analysis based on a covariance matrix using species as the class variable (Table 6). The significance level for inclusion of variables was 0.15 as determined by a multivariate F-test.

**Principal component analysis:** Principal component analyses were conducted using variance-covariance matrices for the included variables. Raw and transformed logarithmic (base 10), and logarithmic (base *e*) data were investigated (Marcus 1990), but only the results obtained from the logarithmic (base *e*) transformed data are presented. Those data were chosen because they exhibited the smallest magnitude and number of departures from normality for variables within each species. Principal component analyses of males that compared pairs of species produced different results that were sometimes diagnostic when results from the complete analysis were less or not at all diagnostic. For this reason, subset analyses comparing each pair of species were performed. The specimens for each subset analysis consisted of all the specimens of the pair of species examined from the males calibration dataset. The *T. minutum* complex was treated as a single unit in subset analyses. Subset analyses of females did not show additional resolution, and only the complete analysis of females is reported.

**Canonical variate analysis:** Canonical variate analyses were conducted using raw data only. Subset analyses were conducted using various combinations of spe-

cies, but failed to show additional resolution, and are not presented.

The absolute value of standardized canonical coefficients can be used to determine the contribution of a variable to a canonical variate (Umphrey 1996). This process is not as simple as analyzing the loadings of variables into principal components (Reyment 1990), and conclusions based on these values must be made very carefully, if any are made at all (Woolley et al. 1994). However, these values were analyzed in this study with the caveat that conclusions more specific than an assessment of contribution to a variate cannot be made with confidence.

**Testing:** Test datasets containing cultures of *T. californicum* for which reproductive compatibility data were not available were analyzed using discriminant functions generated from the calibration datasets.

**Resampling:** Canonical variate analysis, and discriminant analyses in general, have been found to introduce bias for class separation such that they can produce results that are not robust to testing with new observations (Lance et al. 2000). In order to test for replicability, an original variation of the standard jackknife resampling method was used for each canonical variate analysis. This consisted of removing all observations of a culture from the original dataset, with the remaining observations becoming a new calibration dataset, while the removed observations were then used as a test dataset and classified using the linear discriminant function generated from the modified calibration dataset. This was repeated for each culture. This resampling method was chosen to illustrate the recommended method of using the linear discriminant function to classify unknown specimens, and to provide an expected classification error rate per culture for that method.

**Discriminant analysis test class:** Males and females from five *T. californicum* cultures were analyzed only as a test class for

the calibration datasets because conspecificity with other cultures of *T. californicum* could not be verified through reproductive compatibility. These specimens were used to test the discriminant functions derived from the calibration datasets. Test classes using specimens from the same cultures comprising the calibration dataset were not made as this would violate the assumption of independent sampling, leading to unrealistically optimistic results.

## RESULTS

*Univariate and bivariate analyses.*—Tables 3 and 4 list the mean and standard deviation of each character by species for the respective sexes in the calibration datasets. Table 5 lists the ranges of ratios discussed below. There was a pattern of overall size difference between the species in males, in the order of *T. platneri* > *T. minutum* > *T. californicum* > *T. exiguum*. The trend is similar in females, except that specimens of *T. minutum* were slightly larger than *T. platneri*. In no case could males or females of any species be separated without overlap using univariate or bivariate measures. Males of *T. californicum* and *T. exiguum* could be separated from those of the *T. minutum* complex using the length of the longest flagelliform seta (lfs) alone, with minor overlap (Table 3, Fig. 3A). In *T. californicum* and *T. exiguum*, this seta was 0.07 mm or less except for two large specimens of *T. californicum* (lfs = 0.071 mm and 0.073 mm), while that in the *T. minutum* complex was 0.071 mm or greater except for two small specimens of *T. platneri* (lfs = 0.063 mm and 0.068 mm). The size of the specimens is best indicated by the correlated length of the metatibia, which was 0.180 and 0.196 mm in the same specimens of *T. californicum* and 0.125 and 0.158 mm in the two specimens of *T. platneri*.

Males of *T. californicum* can be separated from *T. exiguum* using a ratio of stigmal

Table 3. Univariate statistics for male characters. Means on top with standard deviations in parentheses, and range below. All units in millimeters. Character abbreviations explained in Table 2.

Character	<i>T. californicum</i>	<i>T. exiguum</i>	<i>T. minutum</i>	<i>T. plateri</i>	Average
aed	0.136 (0.013)	0.114 (0.012)	0.151 (0.016)	0.153 (0.018)	0.146 (0.019)
	0.104–0.163	0.099–0.145	0.115–0.186	0.112–0.183	
apd	0.035 (0.003)	0.025 (0.002)	0.036 (0.003)	0.036 (0.003)	0.035 (0.004)
	0.028–0.045	0.020–0.030	0.030–0.044	0.028–0.043	
cla	0.091 (0.012)	0.087 (0.011)	0.107 (0.013)	0.108 (0.013)	0.103 (0.014)
	0.060–0.113	0.067–0.110	0.076–0.138	0.079–0.136	
clb	0.029 (0.004)	0.027 (0.006)	0.033 (0.006)	0.033 (0.006)	0.032 (0.006)
	0.020–0.038	0.018–0.040	0.018–0.045	0.018–0.052	
clc	0.026 (0.005)	0.026 (0.006)	0.031 (0.004)	0.030 (0.005)	0.030 (0.005)
	0.015–0.035	0.015–0.039	0.019–0.041	0.020–0.039	
cld	0.019 (0.003)	0.018 (0.003)	0.022 (0.003)	0.022 (0.003)	0.021 (0.003)
	0.014–0.025	0.011–0.023	0.016–0.031	0.014–0.032	
gcj	0.046 (0.004)	0.041 (0.004)	0.046 (0.005)	0.050 (0.006)	0.047 (0.006)
	0.037–0.055	0.032–0.049	0.036–0.059	0.037–0.064	
ivp	0.038 (0.005)	0.034 (0.004)	0.043 (0.004)	0.024 (0.004)	0.041 (0.005)
	0.028–0.045	0.027–0.041	0.034–0.052	0.029–0.052	
lda	0.080 (0.008)	0.066 (0.009)	0.086 (0.010)	0.093 (0.012)	0.086 (0.013)
	0.058–0.096	0.055–0.093	0.062–0.109	0.069–0.114	
ldl	0.014 (0.002)	0.011 (0.002)	0.016 (0.002)	0.016 (0.002)	0.015 (0.002)
	0.012–0.018	0.009–0.014	0.013–0.021	0.012–0.022	
lfl	0.036 (0.003)	0.032 (0.004)	0.036 (0.004)	0.034 (0.003)	0.035 (0.004)
	0.029–0.043	0.025–0.040	0.026–0.046	0.027–0.043	
lfs	0.063 (0.006)	0.060 (0.005)	0.086 (0.006)	0.080 (0.007)	0.079 (0.011)
	0.051–0.076	0.050–0.069	0.073–0.102	0.059–0.098	
lge	0.133 (0.012)	0.112 (0.010)	0.146 (0.014)	0.150 (0.016)	0.142 (0.018)
	0.105–0.158	0.099–0.140	0.116–0.175	0.114–0.177	
lhm	0.066 (0.005)	0.056 (0.006)	0.064 (0.006)	0.066 (0.005)	0.064 (0.006)
	0.055–0.079	0.043–0.069	0.051–0.079	0.054–0.080	
lmb	0.167 (0.017)	0.149 (0.021)	0.178 (0.024)	0.183 (0.025)	0.176 (0.025)
	0.130–0.201	0.114–0.203	0.127–0.237	0.125–0.228	
lsv	0.041 (0.004)	0.042 (0.005)	0.047 (0.006)	0.047 (0.005)	0.046 (0.006)
	0.034–0.051	0.034–0.057	0.033–0.063	0.037–0.062	
lwg	0.489 (0.044)	0.433 (0.050)	0.522 (0.060)	0.541 (0.060)	0.516 (0.064)
	0.373–0.592	0.342–0.558	0.384–0.654	0.394–0.685	
mta	0.035 (0.005)	0.030 (0.005)	0.034 (0.005)	0.035 (0.005)	0.034 (0.005)
	0.024–0.044	0.024–0.041	0.023–0.049	0.022–0.045	
mtb	0.039 (0.005)	0.033 (0.004)	0.039 (0.006)	0.040 (0.006)	0.039 (0.006)
	0.025–0.048	0.023–0.041	0.025–0.053	0.024–0.055	
mtc	0.031 (0.003)	0.029 (0.003)	0.033 (0.003)	0.033 (0.003)	0.032 (0.003)
	0.026–0.037	0.024–0.037	0.025–0.041	0.027–0.041	
sca	0.078 (0.009)	0.072 (0.010)	0.085 (0.009)	0.085 (0.010)	0.083 (0.010)
	0.060–0.095	0.052–0.093	0.066–0.110	0.063–0.110	
spa	0.026 (0.003)	0.024 (0.003)	0.029 (0.003)	0.030 (0.003)	0.028 (0.004)
	0.020–0.033	0.017–0.033	0.023–0.036	0.021–0.037	
spb	0.029 (0.005)	0.029 (0.004)	0.033 (0.004)	0.035 (0.004)	0.032 (0.005)
	0.018–0.038	0.023–0.039	0.023–0.041	0.023–0.044	
wdl	0.037 (0.003)	0.036 (0.003)	0.041 (0.004)	0.042 (0.005)	0.040 (0.005)
	0.030–0.042	0.032–0.042	0.032–0.051	0.030–0.053	
wgc	0.047 (0.004)	0.042 (0.005)	0.049 (0.005)	0.051 (0.007)	0.048 (0.006)
	0.038–0.056	0.034–0.051	0.037–0.061	0.037–0.064	
wsv	0.006 (0.001)	0.005 (0.001)	0.005 (0.001)	0.006 (0.002)	0.006 (0.001)
	0.003–0.009	0.004–0.007	0.003–0.008	0.004–0.011	
wwg	0.279 (0.029)	0.239 (0.030)	0.291 (0.036)	0.309 (0.039)	0.290 (0.040)
	0.202–0.349	0.187–0.315	0.208–0.373	0.222–0.424	

Table 4. Univariate statistics for female characters. Means on top with standard deviations in parentheses, and range below. All units in millimeters. Character abbreviations explained in Table 2.

Character	<i>T. californicum</i>	<i>T. exiguum</i>	<i>T. minutum</i>	<i>T. platneri</i>	Average
dtv	0.038 (0.003) 0.033–0.043	0.034 (0.004) 0.027–0.040	0.037 (0.004) 0.026–0.050	0.034 (0.004) 0.026–0.042	0.036 (0.004)
lcv	0.089 (0.008) 0.073–0.102	0.084 (0.010) 0.066–0.098	0.087 (0.009) 0.069–0.106	0.086 (0.009) 0.067–0.105	0.087 (0.009)
lfa	0.016 (0.003) 0.012–0.023	0.015 (0.002) 0.011–0.019	0.017 (0.003) 0.011–0.026	0.017 (0.003) 0.010–0.024	0.016 (0.003)
lfb	0.013 (0.002) 0.010–0.017	0.011 (0.002) 0.008–0.015	0.013 (0.002) 0.006–0.020	0.013 (0.003) 0.008–0.020	0.013 (0.002)
lfc	0.015 (0.003) 0.009–0.022	0.012 (0.002) 0.010–0.016	0.013 (0.002) 0.007–0.022	0.013 (0.002) 0.009–0.019	0.013 (0.002)
lfd	0.015 (0.003) 0.010–0.021	0.013 (0.003) 0.007–0.018	0.013 (0.002) 0.007–0.019	0.013 (0.002) 0.008–0.019	0.013 (0.003)
lfl	0.034 (0.003) 0.029–0.043	0.030 (0.002) 0.027–0.036	0.035 (0.004) 0.026–0.046	0.034 (0.003) 0.022–0.044	0.034 (0.004)
lhm	0.065 (0.010) 0.051–0.085	0.059 (0.004) 0.052–0.065	0.064 (0.006) 0.048–0.081	0.067 (0.007) 0.050–0.082	0.065 (0.007)
lsv	0.041 (0.005) 0.031–0.050	0.044 (0.007) 0.035–0.061	0.045 (0.006) 0.032–0.060	0.045 (0.006) 0.033–0.062	0.044 (0.006)
ltv	0.037 (0.003) 0.032–0.042	0.035 (0.004) 0.029–0.040	0.037 (0.004) 0.026–0.048	0.035 (0.004) 0.025–0.043	0.036 (0.004)
lwg	0.519 (0.062) 0.406–0.651	0.463 (0.064) 0.379–0.571	0.516 (0.067) 0.373–0.661	0.532 (0.071) 0.381–0.670	0.519 (0.070)
mta	0.046 (0.007) 0.032–0.062	0.037 (0.006) 0.028–0.047	0.042 (0.007) 0.027–0.059	0.042 (0.007) 0.026–0.061	0.042 (0.007)
mtb	0.048 (0.005) 0.037–0.058	0.040 (0.004) 0.032–0.044	0.046 (0.007) 0.031–0.062	0.046 (0.007) 0.028–0.059	0.046 (0.007)
mtc	0.035 (0.004) 0.028–0.043	0.032 (0.003) 0.027–0.038	0.034 (0.004) 0.026–0.044	0.034 (0.004) 0.025–0.045	0.034 (0.004)
ovp	0.185 (0.018) 0.152–0.222	0.180 (0.024) 0.143–0.218	0.201 (0.023) 0.145–0.245	0.195 (0.025) 0.136–0.233	0.196 (0.024)
sca	0.096 (0.011) 0.075–0.122	0.090 (0.012) 0.072–0.110	0.098 (0.012) 0.068–0.124	0.098 (0.012) 0.072–0.124	0.097 (0.012)
spa	0.027 (0.002) 0.023–0.033	0.024 (0.004) 0.017–0.028	0.028 (0.003) 0.022–0.037	0.029 (0.003) 0.019–0.036	0.028 (0.003)
spb	0.033 (0.005) 0.024–0.043	0.031 (0.005) 0.021–0.038	0.033 (0.004) 0.023–0.043	0.034 (0.004) 0.022–0.046	0.034 (0.005)
svf	0.151 (0.016) 0.119–0.183	0.146 (0.021) 0.116–0.181	0.164 (0.020) 0.113–0.205	0.162 (0.022) 0.108–0.201	0.161 (0.021)
wfa	0.016 (0.002) 0.013–0.021	0.017 (0.002) 0.013–0.022	0.017 (0.002) 0.014–0.021	0.017 (0.002) 0.010–0.022	0.017 (0.002)
wfb	0.013 (0.001) 0.010–0.016	0.014 (0.002) 0.011–0.018	0.015 (0.001) 0.011–0.018	0.014 (0.002) 0.011–0.019	0.014 (0.002)
wfc	0.016 (0.002) 0.012–0.019	0.017 (0.002) 0.013–0.020	0.016 (0.001) 0.013–0.020	0.016 (0.002) 0.012–0.020	0.016 (0.002)
wfd	0.013 (0.002) 0.011–0.017	0.014 (0.002) 0.011–0.016	0.014 (0.001) 0.012–0.018	0.014 (0.001) 0.011–0.019	0.014 (0.001)
wsv	0.007 (0.001) 0.004–0.009	0.005 (0.001) 0.004–0.007	0.005 (0.001) 0.004–0.009	0.006 (0.001) 0.004–0.010	0.006 (0.001)
wtv	0.011 (0.002) 0.007–0.014	0.010 (0.002) 0.007–0.013	0.011 (0.002) 0.006–0.015	0.010 (0.002) 0.007–0.014	0.011 (0.002)
wwg	0.287 (0.040) 0.216–0.370	0.248 (0.038) 0.197–0.314	0.277 (0.041) 0.192–0.376	0.290 (0.046) 0.195–0.382	0.281 (0.043)

Table 5. Ranges of ratios plotted in Figs. 3A–3E.

Ratio	<i>T. californicum</i>	<i>T. exiguum</i>	<i>T. minutum</i>	<i>T. platneri</i>
lfs/wwg	0.59–0.73	0.66–0.80	0.60–0.87	0.57–0.78
lsv/apcd	0.79–1.38	1.36–1.93	0.97–1.71	1.06–1.58
ovp/mtb	3.42–4.26	4.06–5.01	3.62–5.27	3.66–5.80
ovp/wwg	0.59–0.73	0.66–0.80	0.60–0.87	0.57–0.78
lfs/lge	0.22–0.35	0.24–0.40	0.19–0.35	0.17–0.38

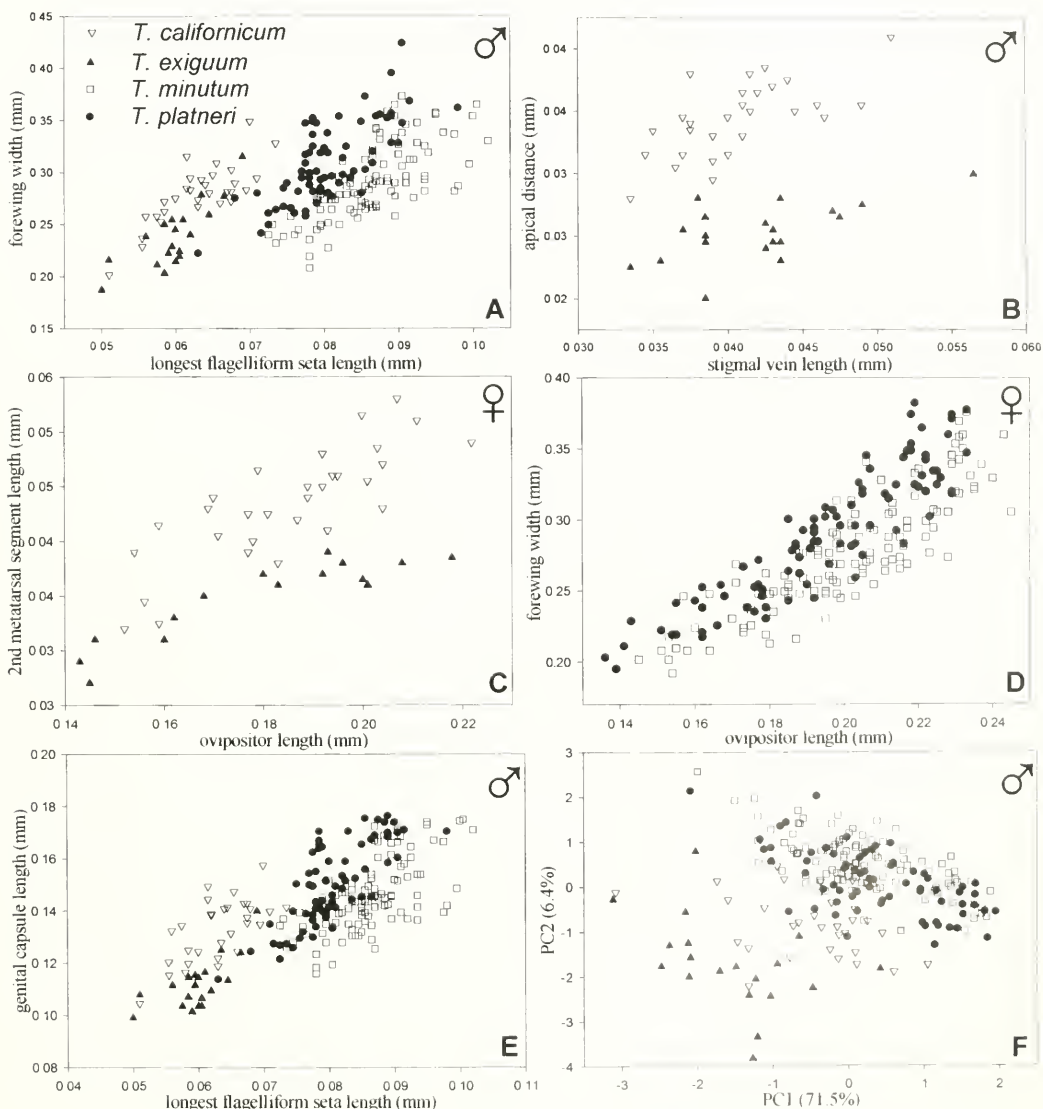

Fig. 3. A–E. Bivariate scatterplots. A, Longest flagelliform seta length vs. forewing width, all species. B, Stigmal vein length vs. apical distance, *T. californicum* and *T. exiguum*. C, Ovipositor length vs. 2nd metatarsal segment length, *T. californicum* and *T. exiguum*. D, Ovipositor length vs. forewing width, *T. minutum* and *T. platneri*. E, Longest flagelliform seta length vs. genital capsule length, all species. F, First two principal components of the male calibration data set, proportion of sample variance in parentheses.

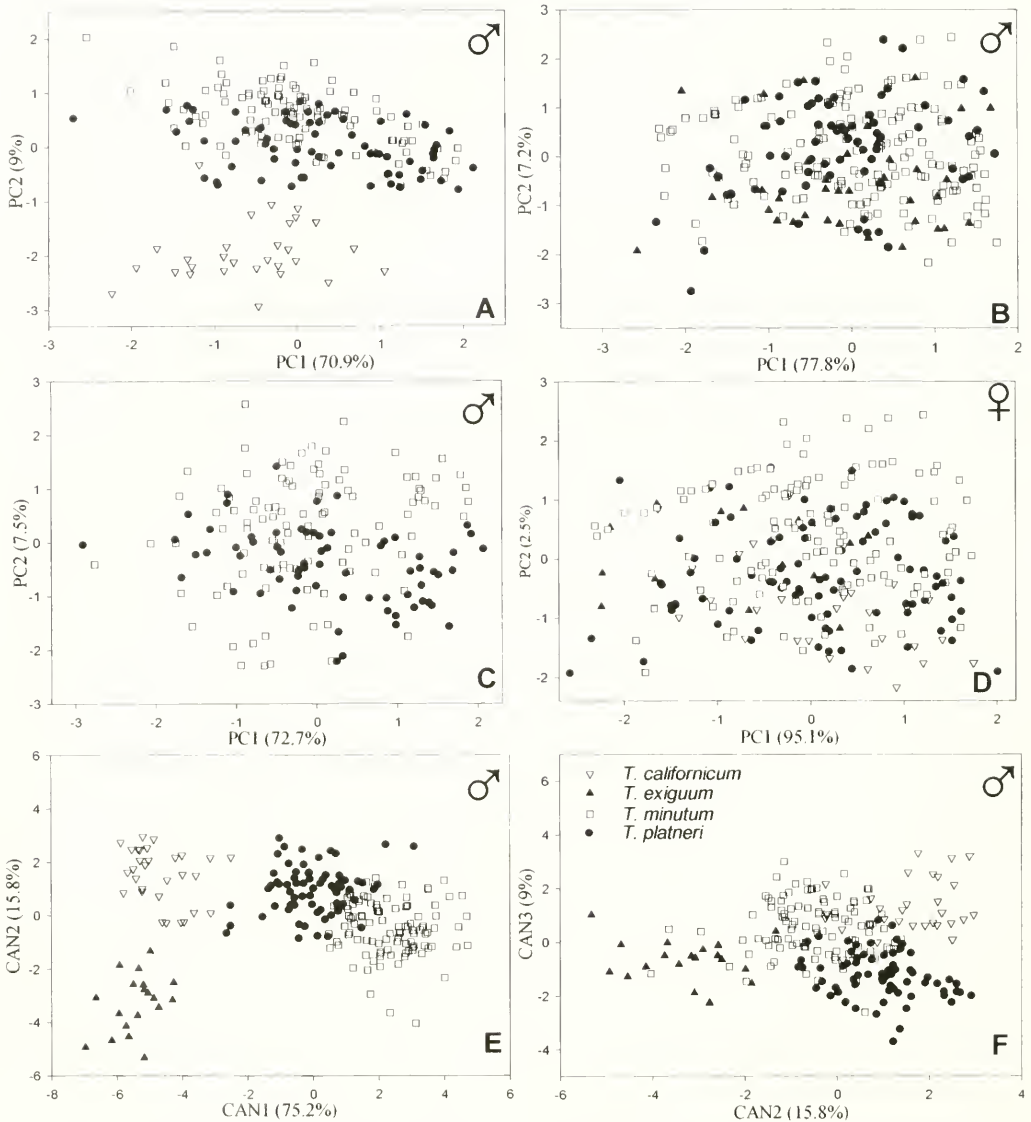

Fig. 4. Plots of first two principal components of selected analyses, proportion of sample variance in parentheses. A, Subset analysis of *T. californicum* vs. *T. minutum* complex males. B, Subset analysis of *T. exiguum* vs. *T. minutum* complex males. C, Subset analysis of *T. minutum* vs. *T. platneri* males. D, Female calibration data set. E-F, Plots of selected canonical variates for males.

vein length (lsv) and apical distance of the genital capsule as measured from the base of the intervolvellar process to the apex of the parameres (apd) (Table 5, Fig. 3B) with overlap involving only one small specimen of *T. exiguum*. In *T. californicum*, the ratio of lsv/apd was less than 1.40, while it was greater than 1.45 in *T. exiguum* ex-

cept for the single unusual specimen (lsv/apd = 1.36; metatibial length = 0.135 mm).

Males of *T. minutum* and *T. platneri* could be partially separated using a ratio of length of the longest flagelliform antennal seta to fore wing width (wwg) (Fig. 3A). In 79% of *T. minutum* males, this ratio

Table 6. Variables selected for multivariate comparisons using stepwise discriminant analysis, listed in descending order of final F value. Bolded variables were selected in four or more separate analyses of males.

Comparison	Variables	Total # of variables/27
<b>Males</b>		
All species	<b>lfs, apd, wdl, ww, gcj, mta, lda, spb, mtb, cla, lmb, wgc,</b> wsv, sca, ivp, lgc, aed, mtc, lsv	19
<i>T. californicum</i> vs. <i>T. minutum</i> complex	<b>lfs, mta, wgc, mtb, apd, wsv, lgc, cla, wdl, ldl, mtc, lda</b>	12
<i>T. californicum</i> vs. <i>T. exiguum</i>	lgc, lsv, sca, <b>ww, spb, lhm, clc, gcj</b>	8
<i>T. exiguum</i> vs. <i>T. minutum</i> complex	<b>lfs, lda, lmb, apd, ivp, spb, gcj, mta, ww, wdl</b>	10
<i>T. minutum</i> vs. <i>T. platneri</i>	<b>gcj, lfs, ww, wgc, lda, wdl, sca, lfl, aed, apd, ivp, mtb, spb</b>	13
<b>Females</b>		
All species	lsv, lmb, lfl, ovp, lcv, dtv, mta, ltv, spa, mtb, svf, lwg, mtc, <b>ww, wsv, lhm</b>	16
<i>T. minutum</i> vs. <i>T. platneri</i>	lfl, lsv, lcv, ovp, <b>ww, dtv, svf, spb, lwg, lhm</b>	10

was greater than 0.28, while it was 0.28 or less in 78% of *T. platneri* males.

In no case could females of any species be completely separated using univariate or bivariate measures, but partial segregation could be found here in ratios involving ovipositor length (ovp). Over 90% of *T. californicum* specimens had a ratio of ovipositor length to 2nd metatarsal segment length (mtb) of less than 4.25, while in 80% of *T. exiguum* specimens the ratio was greater than 4.25 (Table 5, Fig. 3C). The ratio of ovipositor length to fore wing width (ww) provided the best bivariate separation of *T. minutum* and *T. platneri* females (Fig. 3D), although because of the considerable overlap this would not be a useful characteristic for identification (Table 5). In 70% of *T. platneri* specimens, ovp/ww was less than 0.7, while it was greater than 0.7 in 70% of *T. minutum* specimens.

*Principal component analysis.*—The complete analysis of males output no components with strong diagnostic power, but some rough groupings of species were apparent (Fig. 3F). Complete separation was obtained between *T. exiguum* and the *T. minutum* complex based on the first and

second components. Partial separation was obtained between *T. californicum* and the *T. minutum* complex based on those same components, with most of the overlap involving *T. platneri*. The first component appeared to be strongly size correlated with all loadings large and positive (Table 7). Longest flagelliform seta length (lfs) loaded strongly onto the second component (Table 7). The influence of this character is consistent with the findings of the univariate analyses. Although the remaining components in each analysis contained a significant proportion of the variance, they had no more diagnostic value than the first two components and are not reported.

*Subset analyses:* In the analysis comparing *T. californicum* and *T. minutum* complex males only, the second component (Fig. 4A) could be used to separate species, with only one exception, a *T. californicum* specimen from CAYK. All other *T. californicum* specimens were scored at  $-1$  or less on this component, while all *T. minutum* complex specimens were scored at  $-0.924$  or above. The only variable with a high loading on this component was longest flagelliform seta length, which is con-

Table 7. Eigenvalues and loadings for the first two principal components of the covariance matrix of the  $\log_e$  transformed male and female calibration datasets for all species, and the subset analyses of *T. minutum* vs *T. platneri*, the *T. minutum* complex vs *T. californicum*, and the *T. minutum* complex vs *T. exiguum*. Variables selected by stepwise discriminant analysis (Table 6).

Variable	All species, males		<i>T. minutum</i> vs <i>T. platneri</i>		<i>T. minutum</i> complex vs <i>T. californicum</i>		<i>T. minutum</i> complex vs <i>T. exiguum</i>		Variable	All species, females	
	PC1	PC2	PC1	PC2	PC1	PC2	PC1	PC2		PC1	PC2
Eigenvalue	0.216	0.018	0.123	0.013	0.137	0.709	0.148	0.779	Eigenvalue	0.211	0.034
Proportion	0.715	0.064	0.727	0.075	0.709	0.090	0.778	0.072	Proportion	0.690	0.112
aed	0.95	0.05	0.97	-0.10	—	—	—	—	dtv	0.69	0.24
apd	0.83	-0.09	0.84	0.14	—	—	0.86	0.36	lcv	0.92	0.07
cla	0.87	0.28	—	—	0.88	0.27	—	—	lfl	-0.02	0.09
gcj	0.88	-0.20	0.92	-0.27	0.88	-0.17	0.90	-0.21	lhm	0.74	0.01
ivp	—	—	0.66	-0.07	—	—	0.74	0.37	lmb	0.97	0.03
lda	0.93	-0.07	0.94	-0.13	—	—	0.95	-0.04	lsv	0.77	0.13
ldl	0.73	0.09	—	—	0.74	0.15	—	—	ltv	0.75	0.22
lfl	0.01	0.01	-0.01	0.80	—	—	—	—	lwg	0.98	0.01
lfs	0.63	0.70	0.61	0.36	0.63	0.68	0.76	0.57	mta	0.93	0.03
lge	0.96	0.03	—	—	0.95	0.05	—	—	mtb	0.92	0.10
lhm	0.63	-0.34	—	—	0.63	-0.37	—	—	mtc	0.90	0.01
lmb	0.97	-0.11	—	—	—	—	0.96	-0.14	ovp	0.93	0.21
lsv	0.78	0.26	—	—	—	—	—	—	spa	0.80	0.10
mta	0.85	-0.35	—	—	0.86	-0.37	0.88	-0.21	svf	0.93	0.18
mtb	0.86	-0.22	0.87	0.28	0.87	-0.24	—	—	wsv	0.50	-0.86
sca	0.94	0.01	0.93	0.10	—	—	—	—	wwg	0.96	-0.04
scb	0.86	0.19	0.84	0.14	0.87	0.19	—	—			
wdl	0.83	0.09	0.84	-0.14	0.83	0.13	0.86	-0.15			
wgc	0.91	-0.14	0.94	-0.23	0.90	-0.11	0.84	-0.16			
wwg	0.94	-0.12	0.94	0.09	0.94	-0.14	0.96	-0.11			

sistent with the univariate separation involving this variable (Table 3).

In the analysis comparing *T. exiguum* and *T. minutum* complex males, a complete separation is evident based on the first two components (Fig. 4B). The first component had high loadings of all variables, and is assumed to represent size. Longest flagelliform seta length loaded strongly onto the second component (Table 7).

The analysis involving only males of *T. minutum* and *T. platneri* output no components with strong diagnostic power (Fig. 4C). No component except for the first had high loadings of both longest flagelliform seta length and fore wing width, so the partial bivariate separation found using these variables was not upheld in this analysis.

In the principal component analysis of

all females, no component or simple combination of components proved to have diagnostic value (Fig. 4D). Only the first component had high loadings of ovipositor length, 2nd metatarsal segment length, or fore wing width, implying that the partial segregations reported above using these variables were correlated with size. This in itself does not invalidate those patterns, because the first component may contain shape as well as size information (Marcus 1990).

*Canonical variate analysis.*—Males of all species could be discriminated with an overall error rate of 1.35% in the calibration dataset (Table 8). Most of the classification errors involved *T. minutum* and *T. platneri*, but one small specimen of *T. platneri* (metatibial length = 0.158 mm) was identified as *T. californicum*. This specimen was one of the two that overlapped with

Table 8. Results of linear discriminant reclassification of males using the canonical variate results, with error rates.

From	Number classified into species:				Total	% Error
	<i>T. californicum</i>	<i>T. exiguum</i>	<i>T. minutum</i>	<i>T. platneri</i>		
<i>T. californicum</i>	30	0	0	0	30	0
<i>T. exiguum</i>	0	19	0	0	19	0
<i>T. minutum</i>	0	0	98	4	102	3.92
<i>T. platneri</i>	1	0	0	67	68	1.47
Total	31	19	98	71	219	1.35

the grouping of *T. californicum* in the univariate comparison involving longest flagelliform seta length (lfs) (Fig. 3A). The best separation of *T. californicum* and *T. exiguum* from the *T. minutum* complex was found along the first canonical variate (Fig. 4E), with minor overlap between *T. californicum* and *T. platneri*. Longest flagelliform seta length (lfs), genital capsule width at base of dorsal lamina (gcj), and genital capsule width at its widest point (wgc) appeared to contribute the most to this variate according to their standardized canonical coefficient values (Table 9). The large contribution of lfs is consistent

with the univariate separation of these species mentioned earlier, but the relation of the contribution of this variable to that of the genitalic characters is not clear. A plot of lfs and lgc (Fig. 3E) resembles the plot of the first two canonical variates, except that the clouds of points are not circularized as in plots of canonical variates. This similarity helps demonstrate the probable relationship between these raw variables and the canonical variate results.

*Trichogramma exiguum* was best separated from *T. californicum* and *T. platneri* along the second canonical variate (Figs 3E, 3F). Interpretation of the standardized

Table 9. Raw and standardized canonical coefficients for males.

Char.	Raw coefficients			Standardized coefficients		
	CAN1	CAN2	CAN3	CAN1	CAN2	CAN3
Constant	-14.70	-1.97	0.43	—	—	—
aed	38.49	-0.90	82.63	0.75	-0.02	1.60
apd	48.36	-198.70	288.18	0.21	-0.87	1.26
cla	19.38	31.92	-34.96	0.28	0.47	-0.51
gcj	-391.19	-197.72	-286.84	-2.35	-1.19	-1.73
lda	-24.21	-112.43	-118.33	-0.31	-1.42	-1.49
ldl	92.14	-101.29	-59.61	0.22	-0.25	-0.14
lfl	46.24	-8.76	63.29	0.17	-0.03	0.24
lfs	198.05	12.35	-11.67	2.26	0.14	-0.13
lgc	81.68	-10.89	-67.31	1.43	-0.19	-1.18
lhm	-35.83	5.77	-16.77	-0.27	0.04	-0.13
lmb	-24.26	66.63	19.43	-0.61	1.67	0.49
lsv	3.63	70.05	-45.05	0.02	0.43	-0.28
mta	-115.54	-8.43	112.11	-0.61	-0.04	0.59
mtb	-80.94	-77.57	51.38	-0.47	-0.45	0.30
sca	42.31	83.32	58.40	0.42	0.83	0.58
spb	-102.45	66.03	-95.80	-0.46	0.30	-0.43
wdl	88.38	243.56	-47.55	0.41	1.12	-0.22
wgc	187.24	116.12	284.56	1.13	0.70	1.71
wwg	-10.54	-45.62	-16.59	-0.42	-1.83	-0.66

Table 10. Results of linear discriminant reclassification of females using the canonical variate results, with error rates.

From	Number classified into species:				Total	% Error
	<i>T. californicum</i>	<i>T. exiguum</i>	<i>T. minutum</i>	<i>T. platneri</i>		
<i>T. californicum</i>	29	0	1	0	30	3.3
<i>T. exiguum</i>	0	13	1	1	15	13.3
<i>T. minutum</i>	2	2	99	19	122	18.9
<i>T. platneri</i>	3	2	11	76	92	17.4
Total	34	17	112	96	259	13.2

canonical coefficients of this variate cannot be made with confidence because of relatively large contributions of variables from many different body regions.

*Trichogramma platneri* and *T. exiguum* were weakly separated from *T. minutum* and *T. californicum* along the third canonical variate (Fig. 4F). The weak segregation along this variate, although of minor value taken alone, enhances the discriminatory power of the analysis when used in combination with the other variates. Six characters, all from the male genitalia, contributed strongly to this variate: aedeagus length (aed), apical distance (apd), genital capsule width at base of dorsal lamina (gcj), dorsal aperture length (lda), genital capsule length (lgc), and genital capsule width at widest point (wgc). All except aedeagus length describe the shape of the genital capsule.

In the analysis of the calibration dataset

for females, specimens were identified with an overall error rate of 13.2%, mostly involving misidentification of *T. minutum* into *T. platneri* and vice versa (Table 10). *Trichogramma californicum* was weakly separated from the other species along the first canonical variate (Fig. 5A). The largest contribution to this variate was made by ovipositor length (ovp) (Table 11), but there were large contributions from metatibial length (lmb) and 2nd valvifer length (svf). It is likely that this represents part of the strong diagnostic power found using ratios involving ovipositor length, with other variables either correlating with it or correcting it for body size variation. *Trichogramma platneri* was weakly separated from the other species along the second canonical variate. This variable has little discriminatory value taken by itself, but it enhances the discriminatory power of the analysis when used in combination

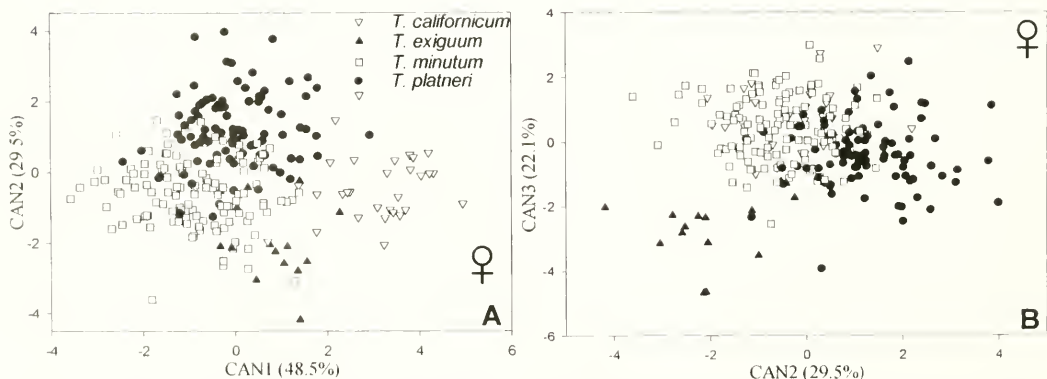

Fig. 5. A-B. Plots of selected canonical variates for females. Proportion of sample variance given in parentheses on axis labels.

Table 11. Raw and standardized canonical coefficients for females.

Char.	Raw coefficients			Standardized coefficients		
	CAN1	CAN2	CAN3	CAN1	CAN2	CAN3
Constant	7.62	7.58	9.02	—	—	—
dtv	56.90	-99.86	177.75	0.24	0.42	0.74
lcv	28.82	-154.06	-4.65	0.26	-1.38	-0.04
lfl	-96.06	-53.47	135.13	-0.34	-0.19	0.48
lhm	24.43	37.08	-15.15	0.18	0.27	-0.11
lmb	59.94	-35.83	-94.04	1.60	-0.95	-2.51
lsv	-74.81	-121.66	-95.35	-0.47	-0.76	-0.60
ltv	195.85	-113.24	-195.16	0.80	-0.46	-0.80
lwg	-18.43	27.79	5.98	-1.28	1.93	0.42
mta	115.19	-17.23	159.81	0.83	-0.12	1.16
mtb	72.00	72.21	118.62	0.49	0.49	0.81
mtc	-40.75	-144.59	-73.53	-0.16	-0.57	-0.29
ovp	-245.01	-54.42	150.43	-5.85	-1.30	3.59
spa	-59.46	138.88	151.21	-0.20	0.47	0.51
svf	134.46	76.00	-137.42	2.82	1.59	-2.88
wsv	157.47	29.18	262.31	0.18	0.03	0.31
wwg	17.25	25.26	6.42	0.75	1.09	0.28

with the other variates. Interpretation of this variate is not clear, as a number of different characters from different body regions contributed strongly to this axis. *Trichogramma minutum* and *T. californicum* were weakly separated from *T. platneri* and *T. exiguum* along the third canonical variate (Fig. 5B). It is similar to the first variate in that ovipositor length contributed very strongly, with high loadings involving metatibial length, 1st metatarsal segment length (mta), and 2nd valvifer length. Even though this variate and the first appear to represent similar sources of variation, it is certain that they do not because canonical variate analysis requires that each variate be uncorrelated with the others.

**Resampling:** Resampling to determine appropriate rates for error of identification was done for cultures of *T. minutum* and *T. platneri* alone, because the method requires a larger sample size of populations relative to specimens than was practical for *T. californicum* and *T. exiguum*, with the result that resampling error rates would tend to be misleadingly high for those species. There was an overall resampling er-

ror rate of 11.76% for males and 29.44% for females (Table 12). Specimen misclassification is more common for certain cultures than for others, and was much higher in females than in males. Ambiguous results (40% error rate or more) for both sexes were rare, occurring in only 2 of the 37 cultures analyzed (MCVA, MWTV), which were also the only cultures ambiguously classified using males. Males of most of the cultures (24) were identified with no errors. A total of 11 cultures were ambiguously classified or misclassified in females, with highly misleading results in some cases. Sample size was 3 or less in 4 of the 11 cultures, but 8 out of 10 females were misidentified from PPND, while none of the 5 males was misidentified. This is taken as a strong indication that, despite the possibility of classifying females using these results, males should be used for more accurate determination.

**Discriminant analysis test class:** Males and females of the five cultures of *T. californicum* without reproductive data were analyzed as separate test classes classified using results from the analyses of the calibration datasets. Among these were the ho-

Table 12. Error rates of resampling cultures in the canonical variate analyses of males and females compared with the error rates from the unmodified analyses. Sample sizes are those in Table 1.

Locality	# Misclassified in calibration		# Misclassified in resampling		Resampling % error	
	Male	Female	Male	Female	Male	Female
<i>T. minutum</i>	4	21	13	38	12.75	31.15
MABQ	0	1	0	1	0	20
MBGS	0	2	0	2	0	25
MBFY	1	0	1	0	33.3	0
MCVA	0	0	5	6	50	60
MCLB	0	0	0	0	0	0
MDRY	0	1	0	2	0	28.57
MFFD	0	1	0	1	0	16.67
MFRU	0	4	1	5	25	83.33
MHND	0	1	0	2	0	28.57
MKNB	0	1	0	2	0	22.22
MKKW	—	1	—	1	—	25
MMDS	0	0	0	1	0	16.67
MEAD	0	3	0	4	0	66.67
MONT	0	1	0	2	0	100
MRHH	0	0	0	0	0	0
MSPL	0	0	0	2	0	25
MSMT	0	1	0	1	0	20
MSMN	0	2	0	2	0	66.67
MSGD	0	0	1	1	25	50
MTRP	0	0	0	2	0	25
MWEN	0	1	1	1	20	25
MWTV	3	1	4	1	40	50
<i>T. platneri</i>	1	13	7	25	10.29	27.17
PBCK	0	0	0	2	0	33.33
PCLV	0	0	1	0	20	0
PCHL	0	0	1	0	20	0
PELT	0	1	0	1	0	25
PGRB	0	1	0	2	0	66.67
PGRN	0	0	0	0	0	0
PJRV	0	0	0	0	0	0
PJUL	0	2	0	3	0	75
PLIB	0	3	1	4	20	44.44
PNWC	1	0	0	0	0	0
PPND	0	5	0	8	0	80
PRV1	0	0	2	0	22.22	0
PSUM	0	0	1	0	25	0
PWWL	0	0	0	2	0	33.33
PWTS	0	1	1	3	20	30
Total all cultures	5	34	20	63	11.76	29.44

lotype male and allotype female from Alturas, CA (CAAL). Of 12 males and 6 females (Table 1), the only misidentified male was one from CAGB, which was identified as *T. platneri*. The holotype male was identified as *T. californicum* with 100% certainty, but the allotype female was iden-

tified as *T. minutum*. The only other misidentified female was a specimen from CAGB, which was identified as *T. exiguum*.

## DISCUSSION

In males, only species of the *T. minutum* complex could not be distinguished with

high confidence using univariate or bivariate analyses, but in all cases where such separation was possible the differences between species were very slight, being measured in thousandths of a millimeter. We do not recommend using these results by themselves for diagnosis, as the already established morphological characters (Pinto 1999) are no less accurate and are in most cases as easy to assess. The partially discriminating ratios given for *T. minutum* complex males and for females of all four species should prove more useful, but the probability of error even in the best of these cases is so high that final diagnosis should not be performed using these characters alone.

The results of the principal component analyses were at best only slightly more diagnostic than the best univariate and bivariate separations. This is not surprising considering that most diagnostic components show strong loadings of the variables singled out as diagnostic in univariate and bivariate analyses. The lack of complete separation between *T. californicum* and *T. platneri* indicates that morphological overlap between the two species is a reality, at least where large specimens of *T. californicum* and small specimens of *T. platneri* are concerned.

Neither males nor females of *T. minutum* and *T. platneri* could be separated using the principal component results, and canonical variate analysis separated them only with some overlap and with a higher degree of accuracy for males over females. These morphological data alone do not clearly support the notion of these as distinct species, but the species are clearly segregated by allozymic data and mutual reproductive incompatibility (Pinto et al. 1992, Burks and Pinto 2002). These data provide for the first time a morphological means of identifying *T. minutum* and *T. platneri*, albeit with some error, and they should facilitate quality control in insectaries that rear both species and in biological control programs that potentially in-

volve both species. Identification remains difficult, however, requiring nineteen measurements for each male specimen, sixteen for each female specimen, and canonical variate analysis. The measurements must be accurate to a thousandth of a millimeter, and all relevant features must be clearly discernable and not distorted for each specimen. It is also recommended that ten specimens, preferably males, of each culture or population be measured to avoid misclassification. These difficulties make morphological identification about as difficult as identification using electrophoresis or crossing with cultures of known identity, and with less accuracy. Nevertheless, situations exist in which morphological identification is necessary, such as when dealing with dead specimens that are not preserved properly for electrophoresis.

One of the major questions in the taxonomy of *Trichogramma* important to biological control is whether the difference between *T. minutum* and *T. platneri* is one of species rank. These results do not answer that question, but they provide more information. Previously, the difference between the two was electrophoretic differences at two allozymic loci and mutual reproductive incompatibility (Pinto et al. 1991, 1992). Stouthamer et al. (2000) recently found that the two species did not differ in ITS2 sequence, which is a genetic region capable of separating morphologically distinct species of *Trichogramma* (Stouthamer pers. comm.). Canonical variate analysis indicates that there are morphological differences, but these differences are complex and involve broad overlap, and we do not consider separations found in canonical variate analysis alone as strong evidence for species separation because of the strong bias for class separation inherent in the method (Lance et al. 2000). This does not necessarily imply that *T. minutum* and *T. platneri* are not distinct species, but that the morphological difference between them is insufficient to sug-

gest that they are fully discrete entities. However, these results can be used to identify *Trichogramma* cultures and field-collected populations. The culture-level resampling results (Table 12) give an overall error rate that should approximate the error encountered in classifying new spec-

imens using the results of this study. Specimens suspected of belonging to species not included in this study can be singled out by treating them as separate groups in the species class variable, but corroborating evidence is ultimately necessary to confirm their identity and distinctness.

#### KEY TO MALE *TRICHOGRAMMA* ANALYZED IN THIS STUDY

[This identification key can be used as a supplement to the key to North American males of *Trichogramma* (Pinto 1999). The canonical variates must be calculated using the product of the raw coefficients and measurements, and corrected for the additive constant generated from the analyses of the males calibration dataset (Table 9). Identification is also possible using discriminant analysis, which is preferable for identifying females and *T. minutum* complex males. Percentages given in parentheses for certain values indicate the proportion of applicable specimens in the calibration dataset for which the statement holds true.]

1. Longest flagelliform antennal setal length (lfs; 21–23, Fig. 1)  $\leq 0.7$  mm (94%). CAN1  $< -3.1$  (98%). If lfs  $> 0.7$  mm then CAN1  $< -4$  ..... 2
- 1'. Longest flagelliform antennal setal length  $> 0.7$  mm (99%). CAN1  $> -2.65$  (100%) ..... 3
2. Ratio of stigmal vein length (53–54, Fig. 1) to apical distance in genital capsule (10–12, Fig. 1) (lsv/apd)  $\leq 1.4$  (100%). CAN2  $< -1.3$  (100%) ..... *T. californicum*
- 2'. Ratio of stigmal vein length to apical distance  $> 1.4$  (95%). CAN2  $> -0.25$  (100%) ..... *T. exiguum*
3. Ratio of longest flagelliform seta length (lfs; 21–23, Fig. 1) to fore wing width (59–60, Fig. 1) (lfs/wwg)  $> 0.28$  (79%). CAN3  $> -0.35$  (82%) ..... *T. minutum*
- 3'. Ratio of longest flagelliform seta length to fore wing width (lfs/wwg)  $\leq 0.28$  (78%). CAN3  $< -0.34$  (88%) ..... *T. platneri*

#### ACKNOWLEDGMENTS

We would like to thank Dr. John D. Pinto and Gary Platner for the use of their cultures, specimen collection, and facilities. We would also like to thank Dr. Gregory P. Walker for comments on the manuscript. This study was supported by grant 96-35312-3890 from the USDA (NRICGP) (John D. Pinto, Principal Investigator) and NSF grant BSR-9978150 (John M. Heraty, Principal Investigator).

#### LITERATURE CITED

- Bookstein, F., B. Chernoff, R. Elder, J. Humphries, G. Smith and R. Strauss. 1985. *Morphometrics in Evolutionary Biology, Special Publication 15*. The Academy of Natural Sciences of Philadelphia.
- Burks, R. A. and J. D. Pinto. 2002. Reproductive and electrophoretic comparisons of *Trichogramma californicum* Nagaraja and Nagarkatti with the *T. minutum* complex (Hymenoptera: Trichogrammatidae). *Proceedings of the Entomological Society of Washington* 104(1): 33–40.
- Falcon, L. A. and J. Huber. 1991. Biological control of the codling moth. Pp. 355–370. In: van der Geest, L. P. S. and H. H. Evenhuis (Eds.). *Tortricid Pests Their Biology, Natural Enemies and Control, Volume 5*. Elsevier: Amsterdam.
- Heraty, J. M. and A. Polaszek. 2000. Morphometric analysis and descriptions of selected species in the *Encarsia streuana* group (Hymenoptera: Aphelinidae). *Journal of Hymenoptera Research* 9: 142–169.
- Kuhlmann, U. and N. J. Mills. 1999. Comparative analysis of the reproductive attributes of three commercially-produced *Trichogramma* species (Hymenoptera: Trichogrammatidae). *Biocontrol Science and Technology* 9: 335–346.
- Lance, R. F., M. L. Kennedy and P. L. Leberg. 2000. Classification bias in discriminant function analyses used to evaluate putatively different taxa. *Journal of Mammalogy* 81: 245–249.
- Marcus, L. F. 1990. Traditional morphometrics. In: *Special Publication No. 2: Proceedings of the Michigan Morphometrics Workshop*. F. J. Rohlf, F. L. Bookstein, eds. The University of Michigan Museum of Zoology: Ann Arbor, MI.

- Meacham, C. A. and T. Duncan. 1987. *MorphoSys, version 1.29*. University of California, Berkeley. (Software).
- Mills, N. J. and K. P. Carl. 1991. Parasitoids and predators. Pp. 235–252. In: van der Geest, L. P. S. and H. H. Evenhuis (Eds.). *Tortricid Pests Their Biology, Natural Enemies and Control. Volume 5*. Elsevier: Amsterdam.
- Nagaraja, H. and S. Nagarkatti. 1973. A key to some New World species of *Trichogramma* (Hymenoptera: Trichogrammatidae), with descriptions of four new species. *Proceedings of the Entomological Society of Washington* 75(3): 288–297.
- Nagarkatti, S. 1975. Two new species of *Trichogramma* [Hym.: Trichogrammatidae] from the U.S.A. *Entomophaga* 20: 245–248.
- Pinto, J. D. 1999. Systematics of the North American species of *Trichogramma* Westwood (Hymenoptera: Trichogrammatidae). *Memoirs of the Entomological Society of Washington* 22: 1–287.
- Pinto, J. D., D. J. Kazmer, G. R. Platner and C. A. Sassaman. 1992. Taxonomy of the *Trichogramma minutum* complex (Hymenoptera: Trichogrammatidae): Allozymic variation and its relationship to reproductive and geographic data. *Annals of the Entomological Society of America* 85: 413–422.
- Pinto, J. D., A. B. Koopmanschap, G. R. Platner and R. Stouthamer. 2002. The North American *Trichogramma* (Hymenoptera: Trichogrammatidae) parasitizing certain Tortricidae (Lepidoptera) on apple and pear, with ITS2 DNA characterizations and description of a new species. *Biological Control* 23(2): 134–142.
- Pinto, J. D., G. R. Platner and E. R. Oatman. 1978. Clarification of the identity of several common species of North American *Trichogramma* (Hymenoptera: Trichogrammatidae). *Annals of the Entomological Society of America* 71: 169–180.
- Platner, G. R., R. K. Velten, M. Planoutene and J. D. Pinto. 1999. Slide-mounting techniques for *Trichogramma* (Trichogrammatidae) and other minute parasitic Hymenoptera. *Entomological News* 110: 56–64.
- Reyment, R. A. 1990. Reification of classical multivariate statistical analysis in morphometry. Pp. 123–144. In: Rohlf, F. J., F. L. Bookstein, (Eds.). *Special Publication Number 2: Proceedings of the Michigan Morphometrics Workshop*. The University of Michigan Museum of Zoology: Ann Arbor, MI.
- Smith, S. M. 1996. Biological control with *Trichogramma*: Advances, successes, and potential of their use. *Annual Review of Entomology* 41: 375–406.
- Stouthamer, R., Y. Gai, A. B. Koopmanschap, G. R. Platner and J. D. Pinto. 2000a. ITS-2 sequences do not differ for the closely related species *Trichogramma minutum* and *T. platneri*. *Entomologia Experimentalis et Applicata* 95: 105–111.
- Stouthamer, R., P. Jochemsen, G. R. Platner and J. D. Pinto. 2000b. Crossing incompatibility between *Trichogramma minutum* and *T. platneri* (Hymenoptera: Trichogrammatidae): Implications for application in biological control. *Environmental Entomology* 29(4): 832–837.
- Umphrey, G. J. 1996. Morphometric discrimination among sibling species in the *fulva-rudis-texana* complex of the ant genus *Aphaenogaster* (Hymenoptera: Formicidae). *Canadian Journal of Zoology* 74(3): 528–559.
- Vincent, D. L. and C. Goodpasture. 1986. Three new species of *Trichogramma* (Hymenoptera: Trichogrammatidae) from North America. *Proceedings of the Entomological Society of Washington* 88: 491–501.
- Woolley, J. B., M. Rose and P. Krauter. 1994. Chapter 12: Morphometric comparisons of *Aphytis* species in the *lingnanensis* group (Hymenoptera: Aphelinidae). Pp. 223–244. In: Rosen, D. (Ed). *Advances in Aphytis Research*. Intercept Ltd. Andover, UK.

## Larval Development and Feeding Behavior of the Wing Dimorphics of *Melittobia digitata* Dahms (Hymenoptera: Eulophidae)

FERNANDO L. CÔNSOLI AND S. BRADLEIGH VINSON

Department of Entomology, Texas A&M University, College Station, TX 77843-2475, USA,  
email: f-consoli@tamu.edu

---

*Abstract.*—*Melittobia digitata* Dahms is an ectoparasitoid of solitary bees and wasps that can develop into two wing morphs. Clutch size and nutrition of the immature have been suggested to induce the morph differentiation in this parasitoid, although supportive data on the effects of nutrition on the morph differentiation is lacking. Here we describe the larval development of the wing morphs and the feeding behavior of *M. digitata* to support the development of an *in vitro* rearing system and further studies on the role of nutrition on the morph differentiation of *M. digitata*. Morphs were produced by rearing the parasitoid at two larval densities (20 and 200 larvae/host), with short wing morphs (SWM) developing from the small clutch and long wing morphs (LWM) from the large one. Morphs had similar larval morphology in all four larval instars. However, development from egg to adult of the SWM was shorter than the LWM (10.1 d vs. 14.5 d). Fourth instars of the SWM developed more slowly than the LWM (85.6 h vs. 46.4 h), while the pupal stage of the LWM was twice as long as that of the SWM (241.8 h vs. 109.0 h). Larvae of *M. digitata* were found to feed on host hemolymph soon after eclosion (12 h), and require 0.79  $\mu$ l/hemolymph to complete their development. Larval mandibles were too short to penetrate or cause significant damage to the host's cuticle, and they might be used only to anchor the larva to the host. Our description of the mouth apparatus of the parasitoid larva, coupled with the data obtained on the host utilization, supports the hypothesis that the early stages of development of this parasitoid obtain the host's hemolymph through the pore canals of the cuticle of the host.

---

*Melittobia* Westwood (Hymenoptera: Eulophidae) are ectoparasitoids of a broad range of solitary wasps and bees (Dahms 1984), and some species can also develop on a variety of facultative hosts in laboratory conditions (R. Matthews, person. com.). *Melittobia* can invade the cell housing its host at any stage of the host development, and wait until the host reaches the most appropriate stage for parasitization (Dahms 1984). The host's pupae are preferred, but late last larval instar or pharate pupae are also accepted (Dahms 1984). *Melittobia* may develop into two different wing morphs depending on their clutch size (Schmiedler 1933, Freeman and Ittyeipe 1982). Wing dimorphism is common among *Melittobia*, and it has been demonstrated not to be a specific genetic

trait (Dahms 1984). The intraspecific competition experienced early during the larval development (clutch size) and/or the nutrition of the larvae were suggested to be the factors that influence wing morph differentiation of this parasitoid (Schmiedler 1933, Freeman and Ittyeipe 1982). Schmiedler (1933) suggested that larval nutrition would trigger the morph differentiation in *Melittobia* because the proportion of long wing morph (LWM) increased with the size of the clutch and both morphs were found to develop from intermediate-sized clutches (Schmiedler 1933). In preliminary studies, we added to Schmiedler's nutritional hypothesis that the longer the larva would feed on a high quality/low energetic-cost diet, higher the proportion of the short wing morph

should be produced. This hypothesis relies on the fact that the larva would expend much less energy to digest and absorb nutrients from the hemolymph than from the host's tissues. We also suggest that the nutritional input would trigger an endocrine response that would result in the differentiation of a specific morph (Cônsoi and Vinson 2002). Changes in the titer of juvenile hormone have been reported as the most common endocrine alteration leading to the development of wing dimorphic species (Zera and Denno 1997). However, little is known on the feeding behavior and larval development of *Melittobia*, information that would facilitate tests to determine the effects of hormones and nutrition on the morph differentiation of this parasitoid.

Here we describe the feeding behavior of the larval stages of *Melittobia digitata* Dahms and the larval development of both morphs. We wanted to determine 1) if short and long-wing morphs differed in their immature development and 2) how much hemolymph was ingested during the immature development of short-wing morphs. We also provide additional data on the morphology of the mouthparts and host utilization by the first instar larva.

#### MATERIALS AND METHODS

*Parasitoid colony.*—A stock culture of *Melittobia digitata* was maintained under laboratory conditions (temperature:  $26 \pm 1^\circ\text{C}$ ;  $60 \pm 10\%$  r.h.; 14L:10D) using *Neobellieria bullata* (Fall.) (Dip., Sarcophagidae) (Carolina Biological Supplies) and *Apis mellifera* L. (Hym., Apidae) pupae as hosts. Hosts were offered for parasitization inside glass tubes (15 cm long  $\times$  1.0 cm in diameter) in a proportion of 1 blowfly pupa: 5 females or 1 honeybee pupa: 10 females. Only parasitoids reared on honeybees were used in our experiments, while *N. bullata* was exclusively used for the maintenance of a stock culture. The parasitized hosts were kept undisturbed under controlled conditions until the pu-

pal stage, when parasitoids were transferred to clean vials.

*Feeding mechanism.*—Honeybee pupae upon which the first instar larva of the parasitoid were feeding were decapitated and fixed in 2.5% glutaraldehyde in 0.1 M cacodylate buffer + 2% acrolein (v/v) for 2 h, washed twice in 0.1 M cacodylate buffer, post-fixed in 2% osmium tetroxide for 30 min, and dehydrated in an alcohol series with final dehydration in propylene oxide. Samples were embedded in epoxy resin and cured at  $60^\circ\text{C}$  overnight. Thin sections (0.5–1.0  $\mu\text{m}$ ) were cut in an ultra microtome (Reichert-Jung) using a diamond histoknife (EdgeCraft Corporation, PA), slide mounted and stained with toluidine blue.

*Determination of the hemolymph content of honeybee pupae.*—Honeybee pupae were injected with 0.01  $\mu\text{C}$   $^{14}\text{C}$ -inulin in 1.0  $\mu\text{l}$  50% ethanol through an inter-segmental membrane, and the tracer was allowed to circulate for 24 h. Inulin is a carbohydrate that has been shown not to be absorbed and thus allows measurements of the extracellular fluids (Levenbook 1979). Samples of 1.0  $\mu\text{l}$  of hemolymph were collected using graduate disposable micro pipettes (Fisherbrand<sup>®</sup>, Fisher Scientific Company, PA), and the radioactivity was determined by liquid scintillation counting. After collection of the hemolymph, honeybee pupae were treated with a 0.6 N solution of tissue solubilizer (ScintiGest<sup>®</sup>, Fisher Scientific Company, PA) and the radioactivity was counted as before. The hemolymph content of honeybee pupae was determined using the radioactivity measured in the aliquot (1.0  $\mu\text{l}$ ) in relation to the total amount injected (0.01  $\mu\text{C}$ ).

*Host utilization.*—Groups of 30 eggs of *M. digitata* were manually transferred to honeybee pupae (125–145 mg) (30 eggs/pupa) previously injected with 0.01  $\mu\text{C}$   $^{14}\text{C}$ -inulin as mentioned before, and kept under controlled conditions. Consumption of the host hemolymph during the parasitoid development was assessed by

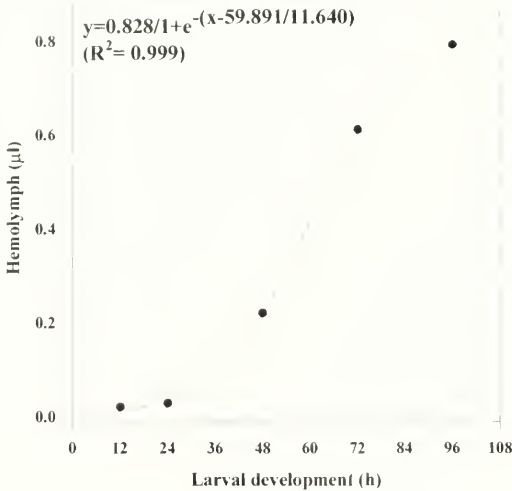

Fig. 1. Individual intake rate of host hemolymph during larval development of *Melittobia digitata* ( $F = 4487.4$ ;  $df = 2, 4$ ;  $P < 0.001$ ).

sampling the parasitoid larvae throughout their development at 12, 24, 48, 72, 96 and 120 h after eclosion, and counting their radioactivity by liquid scintillation. Experiments were replicated six to ten times at each sampling time, with each group of 30 larvae being considered a replication.

*Parasitoid immature development.*—Host-fed, 2 day-old females were offered honeybee pupae for 6 hours for oviposition. Afterwards, eggs were collected and transferred to new pupae at the red-eye stage (110–120 mg). We followed the immature development of *M. digitata* in two clutches: 20 and 200 eggs/host. Larvae developing in the small clutch differentiate into the short wing morph (SWM) while those in the large clutch emerge as the LWM (Cónsoli and Vinson 2002). Larvae were sampled from the host every 12 h from 24 h after parasitization, and fixed in 60% ethanol. Half of the larvae collected in each sample were slide mounted in Hoyer's medium and measurements were taken under a compound phase-contrast microscope (Zeiss) to assess their developmental stage. The other half was processed for scanning electron microscope for detailed observation of the body sur-

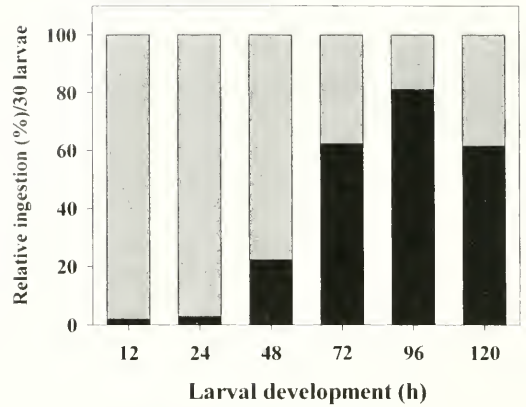

Fig. 2. Host hemolymph consumption during larval development of gregarious parasitoid, *Melittobia digitata*.

face and structures associated with their buccal apparatus. They were transferred to 2.5% glutaraldehyde in 0.1M cacodylate buffer for 2 h and post-fixed in 2% osmium tetroxide (30 min), followed by 2 washes in distilled water and ethanol (50, 70, 90, and 100%), with final dehydration in liquid  $\text{CO}_2$ . Larvae were mounted on double-side carbon tape and viewed in a JEOL SEM at 15 kV.

## RESULTS AND DISCUSSION

*Hemolymph content of honeybees.*—Honeybee pupae have an average hemolymph content of  $29.3 \pm 9.0 \mu\text{l}$  ( $x \pm \text{sd}$ ) at the stage used in this experiment, and no correlation was found between the hemolymph content and the bee size in the range selected (125–145 mg) (Pearson's Correlation test, coefficient =  $-0.07$ ;  $P = 0.74$ ;  $n = 22$ ).

*Host utilization.*—Larvae of *M. digitata* at 12 h after hatching had an intake of  $0.02 \mu\text{l}$  of host hemolymph/larva. The consumption of the host's hemolymph was slow during the first 24 h of the larval development, rapidly increasing through 96 h when the parasitoid is approaching the prepupal stage (Fig. 1). At this stage the larvae had consumed 80% of the host's hemolymph and are terminating their feeding activity (Fig. 2). The end of the feeding

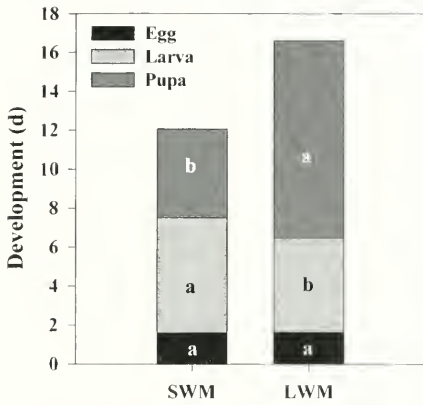

Fig. 3. Development (days) of immatures of both wing morphs of *Melittobia digitata* (SWM = short wing morph; LWM = long wing morph) (Differences in developmental time between each stage of short and long-wing morph are indicated by different letters, Mann-Whitney Rank Sum Test,  $P < 0.05$ ).

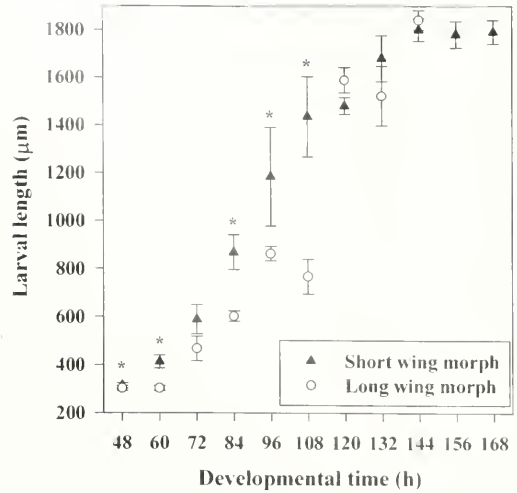

Fig. 4. Larval growth ( $\mu\text{m}$ ) ( $\bar{x} \pm \text{sd}$ ) during development of both morphs of *Melittobia digitata* (\* indicates differences between morphs,  $t$  test,  $P < 0.05$ ).

period is indicated by the lower amount of labeled hemolymph detected at 120 h of parasitoid development, and the drop in label is probably due to the purge of the parasitoid gut content prior to pupation (Fig. 2). Each larva of *M. digitata* required  $0.79 \pm 0.1 \mu\text{l}$  ( $\bar{x} \pm \text{sd}$ ) of host hemolymph to complete its development.

*Parasitoid immature development.*—Egg-adult development of SWMs of *M. digitata* was shorter than the LWMs ( $T = 120.00$ ;  $P < 0.001$ ; Mann-Whitney Rank Sum test), although the larval stage of the SWM was much longer (Fig. 3). Both morphs have four larval stages as indicated by measurements of the larval mandibles, and the prolonged development during the larval stage of the SWM was due to an extended

fourth instar ( $T = 345.00$ ;  $P < 0.001$ ; Mann-Whitney Rank Sum test) (Table 1). SWM molted to the fourth instar earlier and pupated 24 h later than the LWM (Table 1). Although SWM larvae were slightly larger than the LWMs throughout their development and they fed longer on the host, both morphs achieved the same size at the end of their development (Fig. 4).

Despite the differences in the immature development, wing morphs of *M. digitata* had similar external morphology. Eggs are shiny white, almost cylindrical in shape, slightly tapering at one end ( $307.0 \pm 8.3 \mu\text{m}$  long  $\times$   $84.6 \pm 5.2 \mu\text{m}$  wide,  $n = 13$ ), with a short embryonic development period ( $38.8 \pm 5.2 \text{ h}$ ,  $n = 50$ ). Larval morphology remained basically the same

Table 1. Mandible size ( $\mu\text{m}$ ) and development (days) of the larval instars of the short (SWM) and long wing (LWM) morphs of *Melittobia digitata*.

Instar	SWM			LWM		
	Mandible size ( $\mu\text{m}$ )		Development (h)	Mandible size ( $\mu\text{m}$ )		Development (h)
	Length	Ratio		Length	Ratio	
1	$9.4 \pm 0.2$	1.4	$22.8 \pm 3.1$	$9.9 \pm 0.1$	1.3	$23.6 \pm 4.2$
2	$13.1 \pm 0.2$	1.6	$12.0 \pm 0$	$13.4 \pm 0.3$	1.7	$12.0 \pm 0$
3	$21.2 \pm 0.8$	1.7	$14.4 \pm 5.0$	$24.1 \pm 0.5$	1.5	$24.0 \pm 0$
4	$35.4 \pm 0.2$		$85.6 \pm 4.2$	$37.0 \pm 0.4$		$46.4 \pm 4.2$

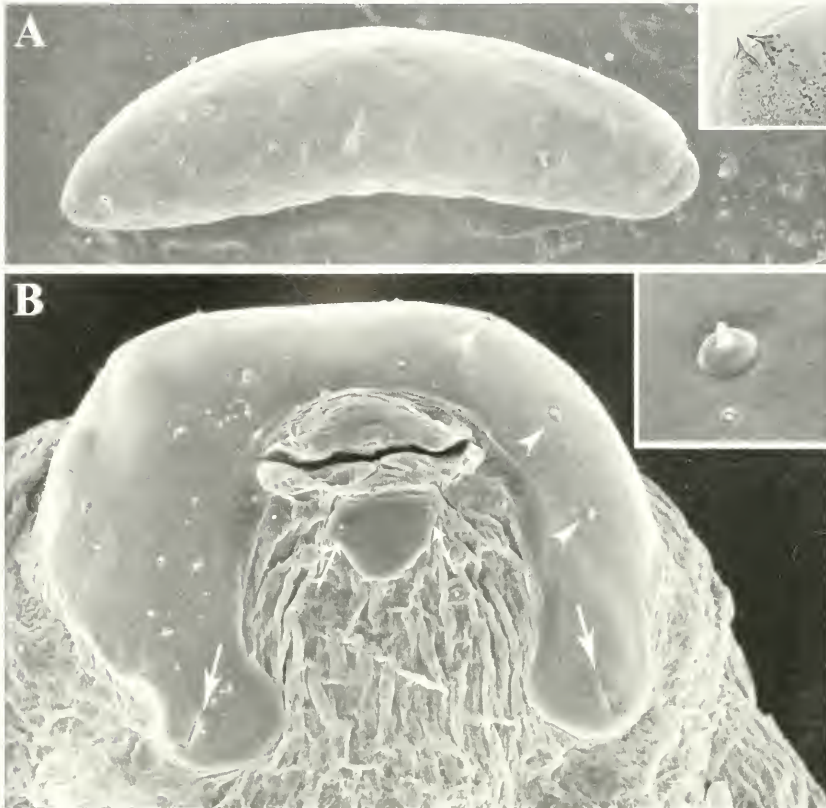

Fig. 5. A. Mature larva of *Melittobia digitata*. Mandibles of fourth instar larva shown in close up; B. Detail of head and mouth opening of fourth instar larva of *M. digitata*. Arrowheads and small arrows indicate presence of sensillae (shown in close up) in pad-like structures surrounding mouth of larva. Large arrows indicate two V-shaped slits at base of pad.

throughout development. Larvae are hymenopteriform, whitish in color, without cuticular appendages or tubercles (Fig. 5A). *M. digitata* has a brief first instar, molting to the second instar after approximately 24 h. Second and third instars are also short, with third instars of SWM developing faster than the LWM ( $T = 142.50$ ;  $P < 0.001$ ; Mann-Whitney Rank Sum test) (Table 1). The fourth instar is the longest larval stage, lasting 46.4 h for the LWM and 85.6 h for the SWM (Table 1). Pupation occurred on the host when parasitoids were reared in a small clutch, but most of the larvae generally abandoned the host before pupating. No cocoon is produced, and the larvae purge their gut content prior to pupation. Feces are black

in color and deposited as round pellets forming a coil, which remains close to the pupae. SWMs also have a reduced pupal development time if compared to the LWMs (SWM = 109.0 h; LWM = 241.8 h;  $T = 276.00$ ;  $P < 0.001$ ; Mann-Whitney Rank Sum test) (Fig. 3).

Although larvae of *M. digitata* lack any kind of locomotory appendage and they are usually found strongly attached to the host surface (see *Feeding mechanism*), movement on the host is quite common. Larvae were found to move soon after hatching, since they were found feeding a few millimeters from where the eggs were placed. Movement was less intense after they attached to the host surface and initiated their feeding. At the end of their de-

velopment, larvae were found to leave the host to pupate as far as a few centimeters from the host. We did not observe any preferential movement from the abdominal area of the host in either clutch size. However, young larvae were most likely to be found feeding close to the intersegmental membranes. Cannibalism was also observed in very few instances where the larvae were developing in a large clutch, and larvae were found feeding on a conspecific at the prepupal or early pupal stage.

Differentiation of the larval stages of *M. digitata* was possible only by measurements of the mandibles. The absence of a well-defined head capsule did not allow the application of Dyar's law for the differentiation of the larval instars. Immature Eulophidae may have from three to five instars, with endoparasitic species usually displaying a lower number of instars than the ectoparasitic ones (Clausen 1962, Hagen 1964, Beaver 1966, Aeschlimann 1969, Bledsoe et al. 1983, Tschudi-Rein and Dorn 2001). Larval morphology is like other species in this group, differing from some endoparasitic species in which the first instar has a small plate-like structure at the caudal segment (Hagen 1964, Beaver 1966, Bledsoe et al. 1983).

Hormones have essential roles in the development of insects, and changes in their levels during the immature stages have been shown to affect the insect development, behavior, physiology (Riddiford 1994, Truman 1996, Li et al. 2001), and morph development which might be cued by a variety of environmental changes (reviewed by Zera and Denno 1997). Alteration in the level of juvenile hormone has been shown to be the most common change in the endocrine system known to induce morph development in other insects, although changes in ecdysteroids and juvenile hormone esterase were also shown to be involved in at least one system (Zera and Denno 1997). Differences in the developmental time of wing morph

species have been quite variable. Comparisons of the developmental time between SWM and LWM indicated no difference for the majority of orthopteroids and hemipteroids studied. Whenever differences were found, the SWM of orthopteroids developed more slowly than the LWM, while the SWM of hemipteroids developed faster (reviewed by Roff 1986). Since these wing morphs are paurometabolous, they would molt straight from the nymphal to the adult stage, and as a result, the nymphal stage would be the only one affected by the morph development. However, in holometabolous, such as *M. digitata*, the pupal stage could also be affected. In *M. digitata* the development of both the larval and pupal stages differed depending on the morph that developed. Short wing morph development was associated with a delayed larval development, but a drastically shortened pupal development period.

Insects are well known to molt when juvenile hormone levels decrease in the presence of ecdysteroids, and the insect has reached a critical weight (Nijhout 1998). Events leading to pupation occur following a small ecdysone peak that prepares tissues and induces metamorphic development in the absence of JH (Riddiford 1994). These changes could be involved in morph development as suggested by the differences in the pre-imaginal development. The arrested development of the fourth instar of the SWMs could be due to the presence of JH at a sufficient concentration to suppress the activity of the prothoracic glands, affecting the release of ecdysteroids (Sakurai et al. 1989, Gu et al. 1997), and it would also delay pupation. On the other hand, the arrested pupal development of LWMs of *M. digitata* could be due to the trade-offs involved in the morph differentiation reported for some other insects (Zera and Denno 1997, Tanaka and Suzuki 1998). In this case, LWMs would require a longer pupal period to allow for the development

of the wing muscles and associated flying structures.

**Feeding mechanism.**—Larvae of *M. digitata* strongly attach to the surface of the host using a pad-like structure that incompletely surrounds the mouth opening (Figs. 5B, 6B). This structure is U-shaped and this shape is found in all instars, but is more conspicuous in the last larval stage (Fig. 5B). This U-shaped pad has around 13–14 sensillar structures symmetrically distributed near the center (Fig. 5B). These sensilla have a pronounced, round socket (ca 4  $\mu\text{m}$  in diameter) with a short, setiform projection (ca 1.8  $\mu\text{m}$  long) (Fig. 5B). Two V-shaped slits are also found at the base of each side of this structure (Fig. 5B). Another pad-like structure, with a triangular-shape, lies under the mouth in between the maxillary palpi, with two smaller sensilla located at its base (Fig. 5B). The mouth opening was never observed completely opened, making difficult the visualization of mandibles and any glandular openings. However, observations in light microscopy showed mandibles with a broad base and a short blade (Fig. 5A).

The larvae open the mouth allowing the alignment of both pad-like structures surrounding the mouth opening, and insert the mandibles into the epicuticle of the host (Fig. 6B–D). These structures are then pressed onto the host surface, forming a closed pouch (Figs. 6C–D). It is likely that digestive enzymes that are released into the pouch will first digest the wax layer covering the cuticle of the host. Despite the fact that depressions in the epicuticle conforming to the mandibles could be seen on the surface of the host (Cooperband 1998), mandibles of the first, second, or even third instars ( $\sim 25 \mu\text{m}$ —Table 1), are too short to penetrate the 30–40  $\mu\text{m}$  thick host's cuticle that would make the host's internal contents directly available to ingestion.

The absence of mandibles long enough to penetrate the host integument and the demonstrated ingestion of hemolymph by

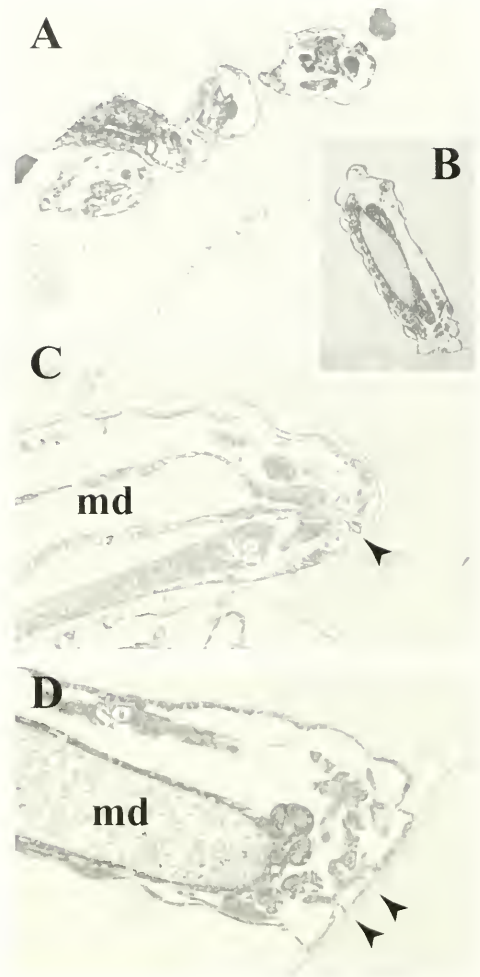

Fig. 6. Sections of larvae of *Melittobia digitata* in development. A. A group of developing first instars showing impressions on wax layer of host cuticle of; B. A first instar larva attached to host cuticle; C. Detail of anterior end of larva, showing base of one mandible of first instar (arrow). Note that pouch formed by attachment of pad-like structure to host cuticle is discrete; D. Detail of pouch formed when pad-like structure of an early third instar is applied against host cuticle; the short blade of the mandibles (arrows) can also be seen (md = midgut; sg = salivary glands).

the first instar larvae of *M. digitata* support Cooperband's hypothesis that acquisition of the host hemolymph by the parasitoid larvae is accomplished by sucking the liquid hemolymph through the pore canals. She proposed that enzymes secreted by

the larvae would digest the wax layer (Fig. 6A, 6C) and the lipids inside the pore canals opening them up to the flow of hemolymph. In fact, a similar phenomenon occurs if some insects are treated with oil. In this case, drops of water can be seen on the surface of the cuticle, and it was indicated that the oil would solubilize the wax layer and the lipids, and as a result hemolymph would be lost through the pore canals (Wigglesworth 1941, 1942). The negative pressure created by contractions of the gut would suck the hemolymph to the surface of the cuticle that would be enclosed by the parasitoid's mouth and subsequently ingested by the larvae (Figs. 6D). Enzymes capable of digesting or dissolving the waxes were demonstrated by the ingestion of the wax layer of the host and by the ingestion of dyed wax by the first instar larvae (Cooperband 1998). However, it is important to consider the fact that *Melittobia* usually develop on hosts at stages in which the host's cuticle is still under development. Thus, the access to the host hemolymph would be facilitated since *Melittobia* could explore hosts in which the endocuticle would be in the early stages of differentiation, facilitating the flow of liquids through the other layers.

Besides the evidence for the ingestion of the host hemolymph by the first instar of *M. digitata*, the epicuticle and wax layer of the honeybee should also be considered a nutritional resource for the developing parasitoid. In addition to the components of the wax layer (hydrocarbons, higher alcohols, organic acids, etc.), the larva of the parasitoid could also benefit from the high amino acid composition of the molting fluid (Hepburn 1985, Reynolds and Samuels 1996, Neville 1998).

The data described here will be useful in the development of experiments in which it will be possible to test the hypothesis that the amount of the host's hemolymph ingested is the nutritional cue in the morph development of *M. digitata*. It

will also allow the recognition and characterization of the stage sensitive to changes in the morph development. Our data will also help in the improvement of the existing *in vitro*-rearing system and facilitate the isolation and characterization of nutrition-born molecules that could be regulating the endocrine system of this parasitoid.

## ACKNOWLEDGMENTS

The authors thank Dr. R. Holloway (Department of Entomology, Texas A&M University) for providing us with honeybees and Dr. H. Sittertz-Batkar (Electron Microscopy Center, Texas A&M University) for providing the facilities and necessary equipment for the work on histology.

## LITERATURE CITED

- Aeschlimann, J. P. 1969. Contribution a l'etude de trois especes d'Eulophides (Hym. Chalcidoidea) parasites de la Tordeuse grise du Meleze, *Zeiraphera diniana* Guenee (Lep. Tortricidae) en Haute-Engadine. *Entomophaga* 14: 261-320.
- Beaver, R. A. 1966. The biology and immature stages of *Entedon leucogramma* (Ratzeburg) (Hymenoptera: Eulophidae), a parasite of bark beetles. *Proceedings of the Royal Entomological Society of London* 41A: 37-41.
- Bledsoe, L. W., R. V. Flanders, and C. R. Edwards. 1983. Morphology and development of the immature stages of *Pediobius foveolatus* (Hymenoptera: Eulophidae). *Annals of the Entomological Society of America* 76: 953-957.
- Clausen, C. P. 1962. *Entomophagous Insects*. McGraw-Hill Co., New York, 688 pp.
- Cônsoli, F. L. and S. B. Vinson. 2002. Clutch size, development and wing morph differentiation of *Melittobia digitata*. *Entomologia Experimentalis et Applicata* 102: 135-143.
- Cooperband, M. F. 1998. Understanding host-acceptance behavior and larval feeding of the parasitic wasp *Melittobia digitata* (Hymenoptera: Eulophidae) to facilitate rearing on an artificial host. MSc. Thesis, Department of Entomology, Texas A&M University. 122 pp.
- Dahms, E. C. 1984. A review of the biology of species in the genus *Melittobia* (Hymenoptera: Eulophidae) with interpretations and additions using observations on *Melittobia australica*. *Memoirs of the Queensland Museum* 21: 337-360.
- Freeman, B. E., and K. Ittyeipe. 1982. Morph determination in *Melittobia*, a eulophid wasp. *Ecological Entomology* 7: 355-363.
- Gu, S. H., Y. S. Chow, and C. M. Yin. 1997. Involvement of juvenile hormone in regulation of pro-

- thoracicotrophic hormone transduction during the early last larval instar of *Bombyx mori*. *Molecular and Cellular Endocrinology* 127: 109–116.
- Hagen, K. S. 1964. Developmental stages of parasites. In: *Biological Control of Insect Pests and Weeds* (DeBach, P. ed.), pp. 168–246. Chapman and Hall, London.
- Hepburn, H. R. 1985. Structure of the integument. In: *Comprehensive Insect Physiology, Biochemistry and Pharmacology* (Kerkut, G. A., and Gilbert, L. I. eds.), Vol. 3, pp. 1–58. Pergamon Press, Oxford.
- Levenbook, L. 1979. Hemolymph volume during growth of *Calliphora vicina* larvae. *Annals of the Entomological Society of America* 72: 454–455.
- Li, H., D. Harrison, G. Jones, D. Jones, and R. L. Cooper. 2001. Alterations in development, behavior, and physiology in *Drosophila* larva that have reduced ecdysone production. *Journal of the Neurophysiology* 85: 98–104.
- Neville, C. 1998. The significance of the insect cuticle. In: *Microscopic Anatomy of Invertebrates—Insecta* (Harrison, F. W., and Locke, M. eds.), Vol. 11A, pp. 151–176. John Wiley & Sons Inc., New York.
- Nijhout, H. F. 1998. *Insect hormones*. Princeton University Press, Princeton.
- Reynolds, S. E., and R. I. Samuels. 1996. Physiology and biochemistry of insect molting fluid. *Advances in Insect Physiology* 26: 157–232.
- Ridiford, L. M. 1994. Cellular and molecular actions of juvenile hormone I. General considerations and premetamorphic actions. *Advances in Insect Physiology* 24: 213–273.
- Roff, D. A. 1986. The evolution of wing dimorphism in insects. *Evolution* 40: 1009–1020.
- Sakurai, S., M. Okuda, and T. Ohtaki. 1989. Juvenile hormone inhibits ecdysone secretion and responsiveness to prothoracicotrophic hormone in prothoracic glands of *Bombyx mori*. *General and Comparative Endocrinology* 75: 222–230.
- Schmieder, R. G. 1933. The polymorphic forms of *Melittobia chalybii* Ashmead and the determining factors involved in their production (Hymenoptera: Chalcidoidea: Eulophidae). *Biological Bulletin* 65: 338–352.
- Tanaka, S., and Suzuki, Y. 1998. Physiological trade-offs between reproduction, flight capability and longevity in a wing-dimorphic cricket, *Modicogryllus confirmatus*. *Journal of Insect Physiology* 44: 121–129.
- Truman, J. W. 1996. Steroid receptors and nervous system metamorphosis in insects. *Developments in Neuroscience* 18: 87–101.
- Tschudi-Rein, K., and S. Dorn. 2001. Reproduction and immature development of *Hyssopus pallidus* (Hymenoptera: Eulophidae), an ectoparasitoid of the codling moth. *European Journal of Entomology* 98: 41–45.
- Wigglesworth, V. B. 1941. Permeability of insect cuticle. *Nature* 147: 116.
- Wigglesworth, V. B. 1942. Some notes on the integument of insects in relation to the entry of contact insecticides. *Bulletin of Entomological Research* 33: 205–218.
- Zera, A. J., and R. F. Denno. 1997. Physiology and ecology of dispersal polymorphism in insects. *Annual Review of Entomology* 42: 207–231.

## Parasitoids Associated with Whiteflies (Homoptera: Aleyrodidae) in Hispaniola and Descriptions of Two New Species of *Encarsia* Förster (Hymenoptera: Aphelinidae)

GREGORY A. EVANS AND COLMAR A. SERRA

(GAE) Florida State Collection of Arthropods Museum, Division of Plant Industry,  
P. O. Box 147100, Gainesville, Florida 32614, USA, email: evansg@doacs.state.fl.us;  
(CAS) Hacienda Ecotopía, Las Terrenas, Samaná, Dominican Republic

---

*Abstract.*—Geographic distribution, host range information and an illustrated key to species (in English and Spanish) of parasitoids associated with whitefly species on the island of Hispaniola are provided. Two **new species**, *Encarsia dominicana* Evans, reared from *Aleurothrixus floccosus* in the Dominican Republic and Florida (USA), and *Encarsia telemachus* Evans, reared from an aleyrodid in Haiti, are described and illustrated. Eight new distribution records and two new hosts records are reported for parasitoids reared from whiteflies in the Dominican Republic.

---

The island of Hispaniola, located in the northern Caribbean Basin, spans nearly 30,000 square miles and is comprised of two countries, the Dominican Republic that covers the eastern two-thirds, and Haiti that covers the western third of the island. Whiteflies attack several agricultural crops grown on the island including field beans, lima beans, cowpea, tomatoes, eggplant, sweet pepper, cucumbers, cantaloupe, watermelon, okra, tobacco, ornamentals, citrus, cassava, cocoyam, palm, banana and others (Serra *et al.* 1996, Donis and Prophete 1997). More than 20 whitefly species have been detected in the Dominican Republic, most of which appear to be associated with a narrow spectrum of plant hosts and rarely cause economic damage to crops. The *Bemisia tabaci* complex in the lowlands and *Trialeurodes vaporariorum* (Westwood) in the mountain valleys are the only whitefly species that are considered to be key pests, particularly in vegetable crops (Serra *et al.* 1996).

Whitefly-transmitted plant viruses cause major economic losses to various crops on the island. The bean mosaic virus, transmitted by the *B. tabaci* complex,

has been reported in both countries since the 1970s. In 1988, *Bemisia argentifolii* Perring and Bellows (or *Bemisia tabaci* biotype B) invaded the island and has caused severe damage to tomatoes by direct feeding, inducing uneven ripening (a phytotoxic disorder), and the transmission of the *Bemisia-geminivirus* complex. The damage caused by whitefly in terms of loss of crop quality and quantity ranged from 20 and 95% from 1988 to 1994 (Alvarez and Abud-Antun 1997). No reliable or statistical data are available for Haiti, but losses associated with the *Bemisia-geminivirus* complex on tomatoes are known to have occurred.

In 1995, tomato growers in the Dominican Republic began to implement improved, integrated management practices including a 3-month host-free period, protected seedbeds, systemic and selective insecticide applications and tolerant and resistant varieties. Due to these measures and increased activity by biological control agents and climatic factors (periods of drought and heavy rainfall), whitefly populations reached an equilibrium at a relatively low level at the beginning of the

1995 season, and growers were able to produce a profitable crop.

As the whitefly population increased later in the season, mass production and inundative release of whitefly parasitoids was discussed as a strategy to stabilize the situation. However, prior to introducing selected exotic parasitoids, it was considered essential to identify the parasitoid species already present in the region and their relative importance. In 1995, a survey of the whitefly species and their endemic and introduced natural enemies was initiated by C. Serra and collaborators at the Instituto Superior de Agricultura (Santiago) in the main production areas of various crops attacked by whiteflies in the Dominican Republic. The goals of survey were to identify the parasitoid species that attack whitefly in the most important agricultural areas in the Dominican Republic, and gather information on their hosts and distribution and relative importance. Laboratory studies were conducted on the

biology of certain parasitoid species. In addition to these collections, we have included records of *Encarsia*, *Eretmocerus* and *Signiphora* species collected by Sabine Tappertrzhofen in yellow pan traps in southern area of the Dominican Republic (from San Cristoban to Azua).

Very little prior knowledge exists regarding the species of whitefly parasitoids that occur on the island. Dozier described *Encarsia catherinae* and *Encarsia haitiensis* (Dozier 1932a) and *Eretmocerus pallidus* (Dozier 1932b) from Haiti. He reported *Encarsia cubensis* Gahan and *Encarsia variegata* Howard (Dozier 1933), *Eretmocerus paulistis* Hempel (misidentification) (Dozier 1932b) and *Eretmocerus serinus* Silvestri (Dozier 1932c) from Haiti. Polaszek *et al.* (1992) reported *Encarsia hispida* and Serra (1992) reported *Encarsia nigricephala* from Dominican Republic. An asterisk is placed before records representing new host and/or distribution records. A host/parasitoid list is given at the end (Table 1).

#### KEY TO PARASITIDS ASSOCIATED WITH WHITEFLIES IN HISPANIOLA

1. Fore wing with marginal and stigmal veins absent; pronotum reaching tegula; body entirely black and heavily sclerotized; female antennal flagellum 8-segmented (Fig. 5), consisting of 5 funicle segments and 3-segmented compact club. Male antennal flagellum with 7 funicle segments and one club segment, F2 with tongue-shaped sensory organ (genus *Amitus*); 1 species known from Hispaniola with fore wing infuscate, and flagellum dark brown with F1 and F2 very elongate and club short with a rounded apex; *ex Trialeurodes vaporariorum*, Dominican Republic ..... *Amitus fuscipennis* MacGown and Nebeker
- 1' Fore wing with marginal and stigmal veins present, pronotum separated from tegula by prepectus, body not entirely black and heavily sclerotized (Chalcidoidea), male and female flagellum with 6 or fewer segments ..... 2
- 2 (1) All tarsi 4-segmented ..... 3
- 2' All tarsi usually 5-segmented, rarely middle leg with 4-segmented tarsus (Fig. 19) ... 7
- 3 (2) Fore wing narrow (Fig. 16), disk length 2× maximum disk width with a row of setae along the wing margin and 1–2 rows transversing the disk; antennal flagellum (Fig. 13) consisting of 2 funicle (one transverse and one cylindrical) and 1 elongate club segment; male antennal flagellum (Fig. 12) with 1 funicle and 1 elongate club segment ..... *Cales noacki* Howard
- 3' Fore wing broad, disk length approximately as long as maximum disk width and with many setae evenly distributed throughout disk; antennal flagellum variable ... 4
- 4 (3') Antennal flagellum 6-segmented consisting of 2 minute anelli, 1 cylindrical funicle segment, and 3-segmented club (Fig. 6); scutellum with 1 pair of setae; stigmal vein elongate (Fig. 20), body yellow with transverse bands on gastral tergites IV–VI; male

- antennal and fore wing characters similar to that of female .....  
 ..... *Neopouphale aleurothrix* (Dozier)
- 4' Antennal flagellum 3-segmented consisting of 2 short funicle segments and 1 elongate club segment (Fig. 7); scutellum with 2 pairs of setae; stigmal vein not as elongate as that of *Neopomphale*; body yellowish; male antennal flagellum consisting of 1 very elongate club segment (Fig. 8) ..... *Eretmocerus*. ..... 5
- 5 (4') F1 very narrow (annelliform), F2 short and triangular; club 5–6× as long as wide, fore wing setae sparse with 1 row of setae under marginal vein; midlobe with 3 pairs of setae ..... *E. serius* Silvestri
- 5' F1 triangular, F2 transverse or quadrate, club 4.0–7.4× as long as wide, forewing setae more dense with more than 1 row of setae under marginal vein; midlobe with 3 pairs of setae ..... 6
- 6 (5') Antennal club length less than 6× width; dorsal surface of club convex contrasting with straight ventral surface; F2 triangular ..... *E. portoricensis* Dozier
- 6' Antennal club 7.3–7.4× as long as wide; dorsal and ventral surfaces of club more or less parallel; F2 transverse ..... *E. pallidus* Dozier
- 7 (2') Antennal flagellum 4-segmented consisting of 3 transverse funicle segments and 1 elongate club (Fig. 9, 10); fore wing disk aetose and; scutellum rectangular, width at least 4/2 its length (Fig. 17); male antenna (Fig. 11) similar to that of female; hyperparasitoids ..... *Siguiophora* ..... 8
- 7' Antennal flagellum 6-segmented, consisting of 3–4 funicle segments and 2–3 club segments, apical segment not greatly elongate (Fig. 4), forewing disk setose; scutellum oval, less than 2× its width; male antennal flagellum with 5–6 segments; female primary parasitoids and male hyperparasitoids ..... *Eucarsia* ..... 9
- 8 (7) Gaster yellow with dark brown, transverse bands on tergites II–IV; head yellow with foramen dark brown; forewing with a dark brown band under the marginal vein (Fig. 15) club 4.1× as long as wide (Fig. 9) ..... *S. aleyrod* Ashmead
- 8' Gaster dark brown with tergite VI and VII yellowish; head dark brown; forewing with a dark brown band under the marginal vein (Fig. 15); club 3.4× as long as wide (Fig. 10) ..... *S. townsendi* Ashmead
- 9 (7') Tarsus of middle leg 4-segmented (apical 2 segments partially fused as in Fig. 19) 10
- 9' Tarsus of middle leg 5-segmented (as in Fig. 2) ..... 15
- 10 (9) Fore wing with aetose area around stigmal vein; F2 of male antenna with round sensorial/glandular process (in species where males are known) .....  
 ..... *E. cubensis* group ..... 11
- 10' Fore wing without an aetose area around stigmal vein; F2 of male antenna without round sensorial/glandular process ..... *E. luteola* group ..... 12
- 11 (13) Body yellow with head and anterior 1/3–1/2 of mesoscutum dark brown; midlobe with 2 pairs of setae ..... *E. nigricephala* Dozier
- 11' Body dark brown with yellow scutellum and central area on gastral tergites I and II; midlobe with 2 pairs of setae ..... *E. cubensis* Gahan
- 12 (10') Head and mesosoma dark brown; gaster yellow with anterior margin of tergite I dark brown, or gaster yellow with dark brown lateral margins ..... 13
- 12' Head and mesosoma entirely yellow or slightly infuscate ..... 14
- 13 (12) Gaster completely yellow (except dark brown base), F1 cylindrical, 0.7× as long as F2; midlobe with 8–10 pairs of setae ..... *E. formosa* Gahan
- 13' Gaster yellow with dark brown lateral margins, F1 quadrate, 0.5× as long as F2; midlobe usually with 8 pairs of setae ..... *E. variegata* Howard
- 14 (12') F1 quadrate, about 0.5× F2; F2 subequal to F3; F6 slightly longer than F5; midlobe with 6 pairs of setae ..... *E. haitiensis* Dozier
- 14' F1 cylindrical, about 0.7× F2; F2 intermediate in length to F1 and F3; F6 very elongate, about 1.2× F5; midlobe usually with 4 pairs of setae ..... *E. hispida* De Santis
- 15 (9') Fore wing with large aetose area around stigmal vein ..... *E. parvella* group ..... 16

- 15' Fore wing without large asetose area under stigmal vein . . . . . 18
- 16 (15) Gaster yellow with transverse, dark brown bands on tergites I, V and VI; apical setae of valvulae III lanceolate; midlobe with 2 pairs of setae . . . . .  
*E. lauceolata* Evans and Polaszek
- 16' Gaster completely yellow or dark brown with yellow lateral margins, TVII and venter; apical setae of valvulae III setiform; midlobe with 4–5 pairs of setae . . . . . 17
- 17 (16') Body usually with large dark brown inverted triangle on midlobe and gaster dark brown with yellow lateral margins, TVII and venter (dark form), body sometimes completely yellow (light form); fore wing infusate under marginal vein; F5 distinctly (1.2×) longer than F4; F6 very elongate and much longer than F5 . . . . .  
*E. tabacivora* Viggiani
- 17' Body bright yellow; fore wing hyaline; F5 slightly longer than F4 and slightly shorter than F6 . . . . . *E. telamachusi* Evans, new species
- 18 (15') Body completely yellow, placoid sensillae on scutellum closer than diameter of one sensillum; fore wing disk with evident area of long setae (Fig. 14); midlobe usually with 4 pairs of setae (sometimes 3 or 5 pairs) . . . . . *E. sophia* (Girault and Dodd)
- 18' Body at least partially dark brown, distance between placoid sensillae variable; fore wing setae uniform; midlobe with 4 pairs of setae . . . . . 19
- 19 (18') F1 cylindrical, 0.7× F2; distance between placoid sensillae on scutellum less than diameter of one sensillum; mesoscutum with 4 pairs of setae; gaster dark brown . . . . . 20
- 19' F1 quadrate (Fig. 1), placoid sensillae on scutellum at least 2.5× diameter of one sensillum apart, gaster yellow with some dark brown tergites . . . . . 21
- 20 (19) Antennae unicolorous, fore wing hyaline, base of gastral tergite VI exceptionally broad . . . . . *E. portoricensis* Howard
- 20' Antennae yellow with F5 and F6 dark brown; fore wing infusate under marginal vein; gastral tergite VI not exceptionally broad . . . . . *E. catherinae* (Dozier)
- 21 (19') Gaster yellow with dark brown tergites IV–VI, F1 quadrate; Sc1 elongate, slightly shorter than Sc2 (Fig. 1–4) . . . . . *E. dominicana* Evans, new species
- 21' Gaster yellow with posterior edge of tergite II to VI dark brown, F1 transverse; Sc1 short, less than 0.5× Sc2 . . . . . *E. perplexa* Huang and Polaszek

#### CLAVE DE LOS PARÁSITOS ASOCIADOS CON ALEIRODIDOS EN LA HISPANIOLA

- 1 Ala anterior sin vena (=nervadura) marginal ni vena estigmática; pronoto tocando la tégula; cuerpo completamente negro y bastante esclerotizado; flagelo de la hembra de 8 segmentos (5 segmentos de funículo, clava compacta y de 3 segmentos); flagelo del macho de 8 segmentos (7 de funículo y 1 de clava), F2 con un órgano sensorial (Genero *Amitus*); 1 especie conocida en la Hispaniola con el ala anterior alhumada, el flagelo café obscuro y F1 y F2 más elongados, y la clava corta con el ápice redondo . . . . . *Amitus fuscipennis* MacGown and Nebeker
- 1' Ala anterior con vena marginal y vena estigmática (aunque muy corta en algunas especies); pronoto separado de la tégula por el prepecto; cuerpo raramente completamente negro (no en las especies en Hispaniola) o muy esclerotizado (Chalcidoidea) . . . . . 2
- 2 (1') Todos los tarsos de 4 segmentos . . . . . 3
- 2' Todos los tarsos usualmente de 5 segmentos, raramente el tarso del segundo par de patas con 4 segmentos (Fig. 19) . . . . . 7
- 3 (2) Ala anterior estrecha (Fig. 16), longitud del disco 2× el ancho, y con una fila de setas por el margin del ala y 1–2 filas atravesando el disco; flagelo (Fig. 13) con 2 segmentos de funículo (1 transverso y otro cilíndrico) y 1 segmento muy alargado de la clava;

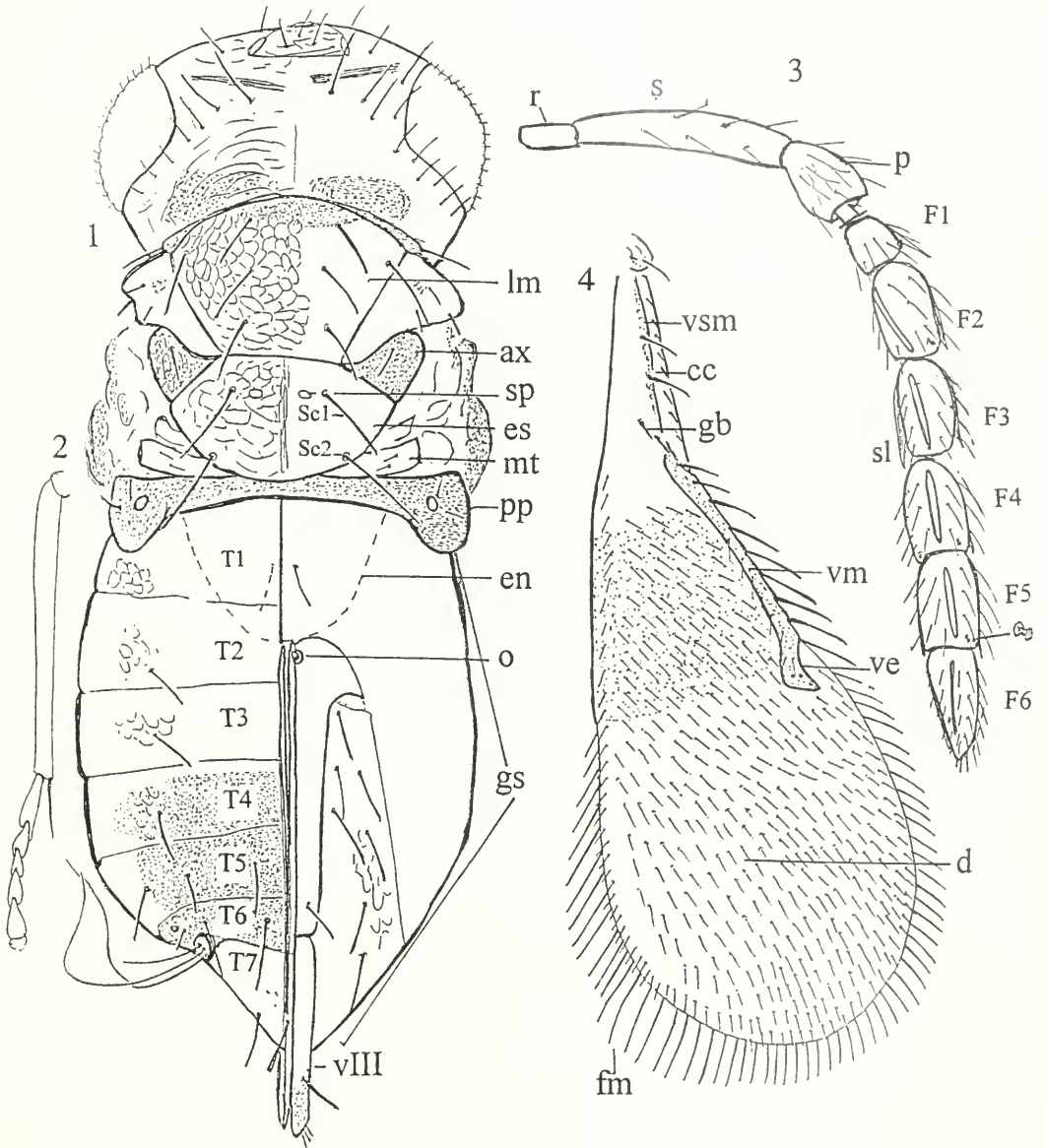

Figs. 1-4. *Encarsia dominicanana*, female. 1. Habitus, mesosoma divided medially with surface sculpture shown on left side; gaster divided medially with dorsal side shown on left side and venter on right. 2. Tibia and tarsus, leg II. 3. Antenna. 4. Fore wing. Abbreviations: (ax) axilla, (cc) costal cell, (d) disk, (en) endophragma, (es) scutellum, (F1-F6) funicle segments 1-6; (fl) flagellum, (fm) marginal fringe, (gb) basal group, (gs) gaster, (lm) median lobe, (me) mesoscutellum, (mt) metanotum, (o) ovipositor, (p) pedicel, (pp) propodeum, (r) radicle, (s) scape, (Sc1) anterior scutellar setae, (Sc2) posterior scutellar setae, (sl) linear sensillae, (sp) placoid sensillae, (ve) stigmatal vein, (vm) marginal marginal, (vsm) submarginal vein, (vIII) valvulae III.

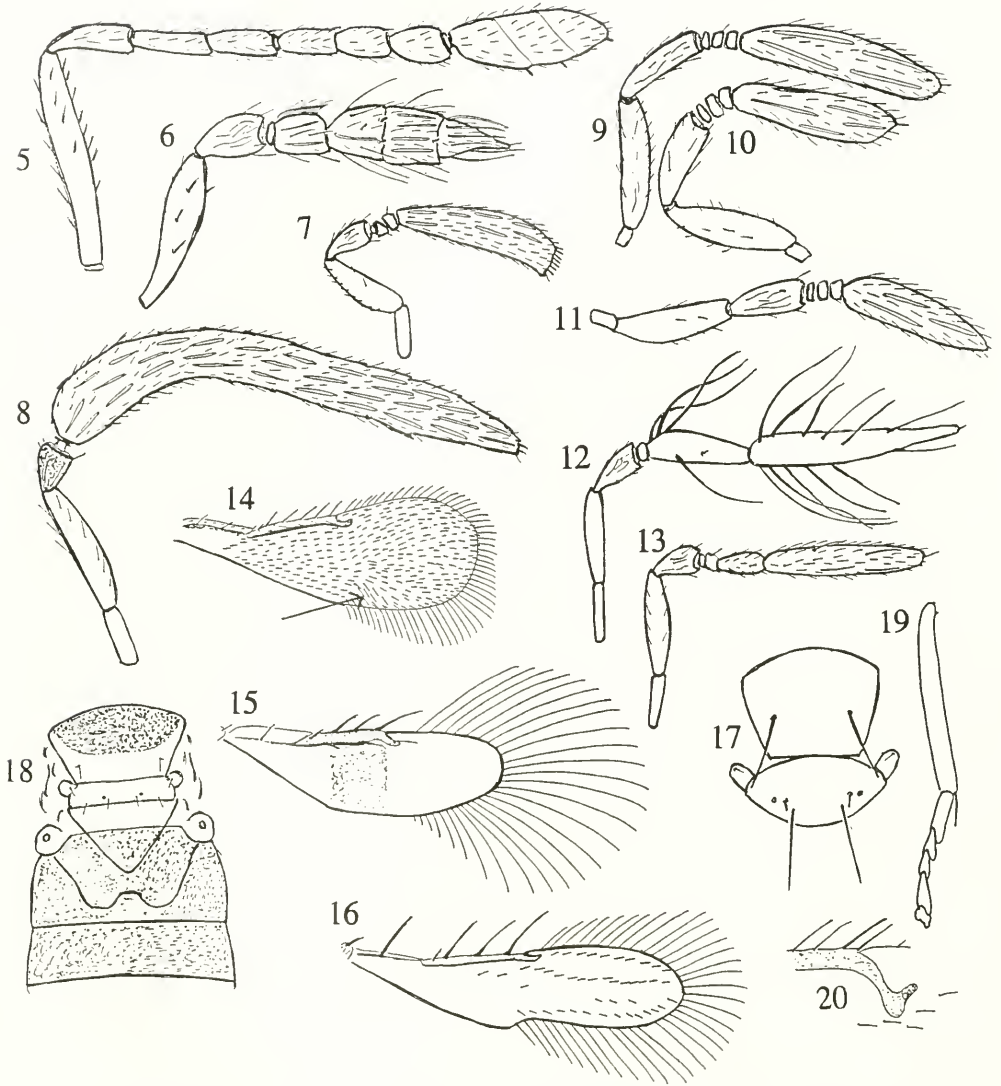

Figs. 5-20. 5-13, Antenna. 5, *Amitus fuscipennis* ♀. 6, *Neopomphale aleurothrix* ♀. 7, *Eretmocerus* sp. ♀. 8, *Eretmocerus* sp. ♂. 9, *Signiphora aleyrod* ♀. 10, *Signiphora townsendi* ♀. 11, *S. townsendi* ♂. 12, *Cales noacki* ♂. 13, *C. noacki* ♀. 14-16, Fore wing. 14, *Encarsia sophia* ♀. 15, *S. aleyrod* ♀. 16, *C. noacki* ♀. 17, *C. noacki* mesosoma ♀. 18, *S. aleyrod* mesosoma and gastral tergites I-II ♀. 19, *Encarsia nigricephala* tibia and tarsus II ♀. 20, *N. aleurothrix* stigmal vein ♀.

- el flagelo de macho (Fig. 12) con 1 segmento de funiculo y 1 segmento muy alargado de la clava ..... *Cales noacki* Howard
- 3' Ala anterior ancha, longitud del disco aproximadamente tan largo como ancho y con muchas setas distribuidas uniformemente a través del disco; flagelo variable ..... 4
- 4 (3') Flagelo de 6 segmentos (2 segmentos de anelli transversos, 1 segmento de funiculo cilíndrico, clava de 3 segmentos (Fig. 6); escutelo con 1 par de setas; vena estigmática elongada (Fig. 20), cuerpo de color amarillo con bandas café sobre los terguitos abdominales IV-VI; flagelo y alas del macho similar a los de la hembra ..... *Neopomphale alenrothrix* (Dozier)

4'	Flagelo de 3 segmentos (2 funículo segmentos cortos y clava de 1 segmento elongado) (Fig. 7); escutelo con 2 pares de setas; vena estigmática no tan larga como en <i>Neopomphale</i> ; color del cuerpo amarillo ó anarajando; flagelo del macho con 1 segmento muy elongado en la clava (Fig. 8) . . . . .	<i>Eretmocerus</i> . . . . .	5
5 (4')	F1 muy estrecho (aneliforme), F2 corto y triangular, longitud de la clava 5–6× más largo que ancho, setas del ala anterior muy escasos con una sola fila de setas debajo de la vena marginal . . . . .	<i>E. serius</i> Silvestri	
5'	F1 más ancho y triangular, F2 transverso o cuadrado, clava 4.0–7.4 más larga que ancha, setas del ala anterior más densas con más de una fila de setas debajo de la vena marginal . . . . .		6
6 (6')	Longitud de la clava menos de 6× del ancho; clava con la superficie dorsal convexa, y la superficie ventral recta; F2 triangular . . . . .	<i>E. portoricensis</i> Dozier	
6'	Longitud de la clava 7.3–7.4× más larga que ancha con las superficies dorsal y ventral más o menos planas; F2 transverso . . . . .	<i>E. pallidus</i> Dozier	
7 (2')	Flagelo con 4 segmentos (3 segmentos del funículo transversos y 1 segmento de clava muy elongado) (Fig. 9, 10); disco del ala anterior sin setas y con una banda de color café debajo de la vena marginal (Fig. 15); escutelo rectangular, por lo menos 4× más ancho que largo (Fig. 17); antena del macho (Fig. 11) parecida a la de la hembra; hiperparasitoides . . . . .	<i>Signiphora</i> . . . . .	8
7'	Flagelo de 6 segmentos (3–4 segmentos de funículo y 2–3 segmentos en la clava), con el último segmento no muy elongado (Fig. 4), ala hialina o ahumada; escutelo oval, menos de 2× más ancho que largo; flagelo del macho con 5–6 segmentos; las hembras son parasitoides primarios y los machos casi siempre son hiperparasitoides . . . . .	<i>Encarsia</i> . . . . .	9
8 (7)	Gáster amarillo con bandas café atravesando los terguitos II–IV; cabeza amarilla con el foramen café obscuro; clava 4.1× más larga que ancha (Fig. 9) . . . . .	<i>S. aleyrodis</i> Ashmead	
8'	Gáster café obscuro con terguitos VI and VII amarillos; cabeza café obscura; clava 3.4× más larga que ancha (Fig. 10) . . . . .	<i>S. townsendi</i> Ashmead	
9 (7')	Tarso del segundo par de patas de 4 segmentos (los 2 segmentos apicales parcialmente unidos) como en la figura 19 . . . . .		10
9'	Tarso del segundo par de patas de 5 segmentos como en la figura 2 . . . . .		15
10 (9)	Ala anterior con un área sin setas alrededor de la vena estigmática; F2 del macho con un proceso sensorial/glandular redondo (en las especies en que el macho es conocido) . . . . .	<b>Grupo de especies <i>E. cubensis</i></b> . . . . .	11
10'	Ala anterior con el área alrededor de la vena estigmática con setas uniformes; F2 del macho sin un proceso sensorial/glandular redondo. . . . .	<b>Grupo de especies <i>E. luteola</i></b> . . . . .	12
11 (10)	Cuerpo amarillo con la cabeza y el anterior 0.3–0.5 parte del mesoescudo café obscuro; lóbulo mediano de mesoescudo con 2 pares de setas . . . . .	<i>E. nigricephala</i> Dozier	
11'	Cuerpo café obscuro con el escutelo y el área central de terguitos abdominales I y II amarillos; lóbulo mediano de mesoescudo con 2 pares de setas . . . . .	<i>E. cubensis</i> Gahan	
12 (11')	Cabeza y tórax de color café oscuro; abdomen amarillo con el margen anterior del tergito I café obscuro, o abdomen amarillo con los lados laterales café . . . . .		13
12'	Cabeza y tórax completamente amarillas o un poco ahumados . . . . .		14
13 (12)	Abdomen completamente amarillo (menos en la base que es café obscuro), F1 cilíndrico y 0.7× de la longitud de F2; lóbulo mediano de mesoescudo con 8–10 pares de setas . . . . .	<i>E. formosa</i> Gahan	
13'	Abdomen amarillo con márgenes laterales café; F1 cuadrado y 0.5× de longitud del F2; lóbulo mediano de mesoescudo usualmente con 8 pares de setas . . . . .	<i>E. variegata</i> Howard	
14 (12')	F1 cuadrado, aproximadamente 0.5× de la longitud del F2; F2 tan largo que F3; F6		

- un poco más largo que F5; Lóbulo mediano de mesoescudo con 6 pares de setas . . . . . *E. haitiensis* Dozier
- 14' F1 cilíndrico, aproximadamente 0.7× de la longitud del F2; longitud de F2 entre el largo de F1 y F3; F6 muy elongado, como 1.2× de la longitud de F5; lóbulo mediano de mesoescudo usualmente con 4 pares de setas (a veces 3 o 5 pares) . . . . . *E. hispida* De Santis
- 15 (9') Ala anterior con una área grande sin setas alrededor de la vena estigmática . . . . . **Grupo de especies *E. parvella*** . . . . . 16
- 15' Ala anterior con setas uniformes alrededor de la vena estigmática . . . . . 18
- 16 (15) Abdomen amarillo con bandas transversas café oscuro sobre I, V y VI; setas apicales de valvulae III lanceoladas (forma de hoja); lóbulo mediano de mesoescudo con 2 pares de setas . . . . . *E. lanceolata* Evans and Polaszek
- 16' Abdomen completamente amarillo (forma clara) o café oscuro con márgenes laterales, amarillos (forma oscura); setas apicales de valvulae III normales (rectas); lóbulo mediano de mesoescudo con 3–5 pares de setas . . . . . 17
- 17 (16) Cuerpo usualmente con una mancha de color café oscuro en forma de triángulo sobre el lóbulo mediano de mesoescudo y abdomen café oscuro con los márgenes laterales pálidas (forma oscura); cuerpo a veces completamente amarillo o anaranjado; alas infuscadas debajo de la vena marginal; F5 1.2× mas largo que F4; F6 muy alargado, mucho mas largo que F5. . . . . *E. tabacivora* Viggiani
- 17' Cuerpo completamente amarillo brillante; alas hialinas, F5 un poco mas largo que F4 y un poco mas corto que F6 . . . . . *E. telamachus* Evans, sp. nov.
- 18 (15') Cuerpo completamente amarillo, distancia entre los sensillae placoides del escutelo menor del diámetro que de un sensillum; parte posterior del disco del ala anterior con una área de setas más largas que otras (Fig. 14); lóbulo mediano de mesoescudo usualmente con 4 pares de setas (a veces 3 o 5 pares) . . . . . *E. sophia* (Girault and Dodd)
- 18' Cuerpo por lo menos parcialmente café oscuro o negro, distancia entre los sensillae placoides variable; setas del ala anterior uniformes; lóbulo mediano de mesoescudo con 4 pares de setas . . . . . 19
- 19 (18') F1 cilíndrico, longitud 0.7× del F2; distancia entre los sensillae placoides del escutelo menor del diámetro de un sensillum; lóbulo mediano del mesoescudo con 4 pares de setas; abdomen café oscuro . . . . . 20
- 19' F1 cuadrado (Fig. 1), distancia entre los sensillae placoides por lo menos 2.5× el diámetro de un sensillum; abdomen amarillo con unas áreas de color café sobre algunos terguitos . . . . . 21
- 20 (19) Flagelo amarillo, ala hialina, base del tergito VI de abdomen excepcionalmente ancha . . . . . *E. portoricensis* Howard
- 20' Flagelo amarillo con F5 y F6 café oscuro; ala ahumada debajo de la vena marginal; tergito VI de abdomen no excepcionalmente ancho . . . . . *E. catherinae* (Dozier)
- 21 (19') Abdomen amarillo con terguitos IV–VI café oscuro; F1 cuadrado; lóbulo mediano del mesoescudo con 4 pares de setas (Figs. 1–4) . . . . . *E. dominicana* Evans, sp. nov.
- 21' Abdomen amarillo con terguitos I y II café oscuros; F1 transverso, lóbulo mediano del mesoescudo con 5 pares de setas . . . . . *E. perplexa* Huang and Polaszek

Family Aphelinidae

*Cales noacki* Howard

(Figs. 12, 13, 16, 17)

*Cales noacki* Howard 1907:82

*Hispaniola* records.—HAITI, Kenskoff, 5.xi.1929, ex *Aleurothrixus* n. sp. on *Prunus*

*myrtifolia*; Cote Plage, 21.xi.1930 and Port-au-Prince, 18–19.vi.1931, ex *Aleurothrixus floccosus* on mahogany (*Swietenia* sp.); Damien, 21–23.iii.1931, ex *Aleurothrixus* n. sp. on *Catalpa longissima* (Dozier 1933).

*Comments*.—Traditionally, the genus *Cales* has been placed in the family Aphel-

inidae. Taxonomists have debated this placement (Hayat 1994, Woolley 1997), some suggesting that the genus is better placed in the Trichogrammatidae, while others consider it to be more closely related to the Eulophidae or the Mymaridae. The original host record (*Orthezia*) for this parasitoid species is probably erroneous. We suspect that the sample was contaminated with *Aleurothrixus floccosus* or some other whitefly species. Contrary to Viggiani and Carver's (1988) statement that this species has 1 pair of setae on the scutellum, we found 2 pairs of setae on the scutellum (Fig. 18); one pair of very elongate setae are present along the posterior margin of the scutellum and one pair of very minute setae are located adjacent to the placoid sensillae.

#### *Encarsia catherinae* (Dozier)

*Trichoporus catherinae* Dozier 1933:92

*Hispaniola records*.—HAITI, Damien, 1 XI 1931, ex *Aleuroplatus* sp. (USNM).

#### *Encarsia cubensis* Gahan (Fig. 19)

*Encarsia cubensis* Gahan 1931:121.

*Trichoporus cubensis* (Gahan), Dozier 1933:92.

*Hispaniola records*.—DOMINICAN REPUBLIC, Azul Province, Las Charcas, 16.i.1995, C. Serra, ex *Bemisia tuberculata* on *Manihot esculenta*; HAITI, Damien, 6–15.xii.1930, H.L. Dozier, ex *Aleurothrixus floccosus* on *Spondias mombin*; Sarth, 26.i.1931, ex *Aleurothrixus floccosus* on *Guaiacum officinale* (Dozier 1933).

#### *Encarsia dominicana* Evans, new species (Figs. 1–4)

*Encarsia brasiliensis* (Hempel): misidentification  
Dozier 1932a:121; Grissell 1979:2.

*Type material*.—Holotype female, DOMINICAN REPUBLIC, Las Terrenas, iv.1998, C. Serra, ex *Aleurothrixus floccosus*, in United States Natural History Museum, Washington, D.C., USA; 3 female para-

types and 1 female (unemerged, inside the whitefly pupa), same data as holotype.

*Diagnosis*.—The female of *E. dominicana* is similar to *Encarsia bellottii* Evans and Castillo and can be distinguished from that species which has the gastral tergites I and II dark brown, the F1 antenna segment transverse, and 2 pairs of setae on the mesoscutum. In *E. dominicana*, the gaster is yellow with the central portion of tergites IV, V, and VI entirely dark brown, the F1 antenna segment is quadrate, and there are 4 pairs of setae on the mesoscutum. It is also similar to *Encarsia perplexa* Huang and Polaszek, a species which has often been misidentified as *Encarsia opulenta*, but differs from this species by having the gaster yellow with dark brown tergites IV–VI, F1 quadrate and the Sc1 setae elongate, slightly shorter than Sc2. In *E. perplexa*, the gaster is yellow with posterior edge of tergite II to VI dark brown, F1 is transverse and Sc1 setae is short, less than  $0.5 \times$  Sc2.

*Description*.—Female (Fig. 1). Coloration. Head yellowish with dark brown, transverse band at level of foramen; mesosoma yellow with anterior margin of midlobe and axillae dark brown; legs and antennae yellow; metanotum dark brown; metasoma yellow with tergites IV–VI and apical third of valvulae III dark brown; fore wing hyaline with faint infuscation under marginal vein to posterior margin of wing. Structure. Antenna (Fig. 3) with 3-segmented club, F1–F6 with the following number of linear sensilla: F1:0, F2:2, F3:3, F4:3, F5:3, F6:3. Midlobe of mesoscutum broad,  $1.5 \times$  as wide as long, with roundish hexagonal reticulations and 4 pairs of setae; each side lobe with 3 setae, each axilla with 1 seta located apically and extending almost to the base of the axilla; scutellum with Sc1 reaching bases of Sc2, distance between placoid sensilla about  $3 \times$  the width of one sensillum; endophragma reaching middle of gastral tergite I; tibial spur of middle leg (Fig. 2)  $0.9 \times$  corresponding basitarsus; fore wing

(Fig. 4) broad, disc length 1.0–1.1× disc width; 2–3 basal group setae, marginal vein with 7 long and stout setae along its anterior margin, 2 parastigmal setae at its base, discal setae uniformly distributed; marginal fringe 0.2× disc width; gastral dorsum with imbricate lateral margins on tergites I–IV, becoming weak on tergite V, and stipuled on VI and VII; tergites I–VII with 0, 1, 1, 1, 3, 3, and 2 pairs of setae, respectively; ovipositor arising at center of tergite II, length 1.6–1.7× length of tibia of middle leg; valvulae III length 0.4× that of ovipositor.

*Male*.—Unknown.

*Distribution*.—DOMINICAN REPUBLIC; HAITI; USA: Florida.

*Host*.—*Aleurothrixus floccosus*.

*Hispaniola records* (in addition to the holotype).—HAITI, Kenskoff, 5–8.xi.1929, ex *Aleurothrixus* n. sp., on *Prunus myrtifolia*; Damien, 15.xii.1930, ex *Aleurothrixus floccosus* on *Spondias mombin* (Dozier 1932a).

*Etymology*.—This species is named for the people of the Dominican Republic.

*Comments*.—Dozier (1932a) redescribed *Eucarsia brasiliensis* (Hempel) based upon the specimens from Haiti mentioned above. The original description of this species by Hempel (1904) states that *E. brasiliensis* is entirely yellow and has a 4-segmented tarsus on the middle leg. Hempel's species is a member of the *Eucarsia luteola* species group and will be redescribed elsewhere from topotypical specimens by Polaszek and Evans.

### *Eucarsia formosa* Gahan

*Eucarsia formosa* Gahan 1924:14.

*Hispaniola records*.—\*DOMINICAN REPUBLIC, La Vega Province, Constanza, 1992, S. Tappertzhofen, ex whitefly on *Euphorbia pulcherrima*; Santiago Province, La Herradura, 4.iv. 1995, C. Serra, ex *Bemisia tabaci* complex, on *Euphorbia pulcherrima*; La Vega Province, El Rio, Constanza, 25.v.95, C. Serra, ex *Trialeurodes vaporariorum* on *Manihot esculenta*.

### *Encarsia haitiensis* Dozier

*Encarsia haitiensis* Dozier 1932a:118.

*Hispaniola records*.—Holotype female, HAITI, Damien, 15.xii.1930, H.L. Dozier, ex *Aleurothrixus floccosus* on *Spondias mombin*, in USNM; HAITI, Sarthe, 16.i.1931, ex *Aleurothrixus floccosus* on *Guaicum officinale* (Dozier 1933).

### *Encarsia hispida* De Santis

*Encarsia hispida* De Santis 1948:47.

*Hispaniola record*.—DOMINICAN REPUBLIC, ex *Bemisia tuberculata* on *Manihot esculenta*, x.1991, P. Stansly (Polaszek et al. 1992:383).

### *Encarsia lanceolata* Evans and Polaszek

*Encarsia lanceolata* Evans and Polaszek 1997:564.

*Hispaniola records*.—\*DOMINICAN REPUBLIC, Samaná Province, Puerto Escondido, 22.vi.1996, C. Serra, ex *Bemisia tabaci* on unknown plant; Santiago Province, La Herradura, C. Serra, ex \**Aleurodicus* sp. on ornamental palm (probably *Sabal* sp.); C. Serra, ex *Tetraleurodes acaciae* on *Centrosema pubescens*. \*HAITI, Morno a Cabrito, 22.xii.1930, H. L. Dozier, ex *Paraleyrodes* or *Tetraleurodes* sp.

### *Encarsia nigricephala* Dozier

*Encarsia nigricephala* Dozier 1937:129.

*Hispaniola records*.—DOMINICAN REPUBLIC, San Cristobal Province, San Cristobal, 15.v.1990, C. Serra, ex *Aleurotrachelus* sp. on *Lycopersicon esculentum*; Santiago Province, La Herradura, Santiago, 13.vi. 1995, C. Serra, ex *Aleurotrachelus trachoides* on *Capsicum annuum*; San Jose de las Matas, 26.xi.1995, C. Serra, ex *Bemisia tabaci* complex on *Sida* sp.; Peravia Province, Bani, 16.iv.1995, C. Serra, ex *Aleurotrachelus trachoides* on *Merremia* sp.

### *Encarsia perplexa* Huang and Polaszek

*Encarsia perplexa* Huang and Polaszek 1998: 1934.

*Prospaltella opulenta* Silvestri; Grissell 1979:2 misidentification.

*Encarsia opulenta* (Silvestri); Schauff *et al.* 1996: 23 misidentification.

*Hispaniola records.*—DOMINICAN REPUBLIC. *E. perplexa* (as *E. opulenta*), introduced into the Dominican Republic in 1996, was very efficient in controlling citrus blackfly (A. Abud, personal communication).

*Comments.*—*Encarsia perplexa* has often been misidentified as *Encarsia opulenta* (Silvestri), especially those specimens from the New World. According to Huang and Polaszek (1998), the midlobe of *E. perplexa* is dark only proximally, T1 and T2 of gaster are largely pale and F2 is less than 2× as long as wide; as opposed to *E. opulenta*, which has the midlobe, T1 and T2 completely dark brown, and F2 more than 2× as long as wide.

#### *Encarsia portoricensis* Howard

*Encarsia portoricensis* Howard 1907:77.

*Hispaniola records.*—DOMINICAN REPUBLIC (De Santis 1979). New Record: Samaná Province, Las Terrenas, iv.1995, C. Serra, *ex Aleuroglandulus malangae* on *Xanthosoma sagittifolium* and *Caladium* sp.

*Comments.*—Russell (1934) reported this species as a parasitoid of the diaspine scale, *Comstockiella sabalis* (Comstock). Evans and Pedata (1997) considered this record to be an erroneous identification of the male of *Coccobius donatellae* Pedata and Evans.

#### *Encarsia sophia* (Girault and Dodd) (Fig. 14)

*Coccoplagus sofia* Girault and Dodd 1915:49.

*Encarsia transvena* (Timberlake), See Heraty and Polaszek (2000) for complete synonymy.

*Hispaniola records.*—DOMINICAN REPUBLIC, Santiago Province, San Jose de las Matas, 15 vii 96, M. Ortiz, *ex Trialeurodes vaporariorum* on *Phaseolus vulgaris*; Santiago Province, La Herradura, *ex Aleurodicus dispersus* on ornamental; San-

tiago, 24.iv.1995, C. Serra, *ex Bemisia tuberculata* on *Manihot esculenta*; La Vega Province, Jarabacoa, 13.vi.1995, C. Serra, *ex Bemisia tabaci* complex on *Brassica oleracea*.

#### *Encarsia tabacivora* Viggiani

*Encarsia bemisiae* De Santis 1981:37 (name preoccupied by *Prospaltella bemisiae* Ishii).

*Encarsia tabacivora* Viggiani 1985:82.

*Hispaniola records.*—\*DOMINICAN REPUBLIC, Santiago Province, San Jose de las Matas, 5.vi.1996, C. Serra, *ex Bemisia tabaci* on *Baccharis sativas*; Santiago Province, La Herradura, *ex Bemisia tabaci* on *Solanum melongena*; La Herradura, *ex Aleurodicus* sp. on ornamental palm (probably *Sabal* sp.); La Herradura, 18.ii.1995, *ex Trialeurodes vaporariorum*; Peravia Province, Los Ranchitos, i.1994, S. Tappertzhofen, *ex* whitefly on *Solanum melongena*; San Cristobal Province, San Cristobal, ix.1993, S. Tappertzhofen, yellow trap; La Vega, Jarabacoa (>500 masl), 18.i.1996, C. Serra, *ex Bemisia tabaci* and *Trialeurodes vaporariorum* on *Gerbera* sp.; Azua Province, La Cabuya, I.1994, S. Tappertzhofen, yellow trap and ix.1993, whitefly on *Solanum melongena*; Santiago, La Herradura, 18.ii.1995, C. Serra, *ex Bemisia tabaci*.

#### *Encarsia telemachus* Evans, new species (Figs. 21–24)

*Type material.*—Holotype female, HAITI, Source, Cazeau, 25.xii.1930, H. L. Dozier, *ex "Asterochiton bauhinae"* [= *Trialeurodes floridensis?*], on *Bauhinia divaricata*, in United States Natural History Museum, Washington, D.C., USA; 2 female paratypes, same data as holotype.

*Diagnosis.*—The female of *E. telemachus* is similar to the light form of *E. tabacivora* Viggiani and can be distinguished by having a bright yellow body, hyaline fore wing and F5 slightly longer than F4 and slightly shorter than F6; in the light form of *E. tabacivora*, the body a darker yellow, with tergite VI slightly infuscate, the fore

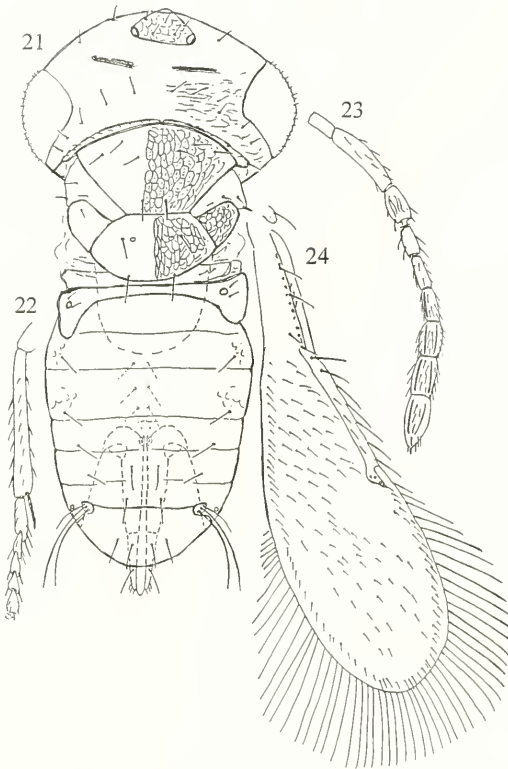

Figs. 21–24. *Encarsia telemachus*, female, 21, Habitus. 22, Tibia and tarsus, leg II. 23, Antenna. 24, Fore wing.

wing is infuscate under the marginal vein and F5 is distinctly ( $1.2\times$ ) longer than F4 and much shorter than F6.

*Description.*—Female. Coloration (Fig. 21). Body bright yellow, fore wing hyaline. Structure. Antenna (Fig. 23) with 3-segmented club, F1–F6 with the following number of linear sensilla: F1:0, F2:0, F3:2, F4:3, F5:3, F6:3. Midlobe of mesoscutum broad,  $1.8\times$  wider than long, with elongate, hexagonal reticulations and 4 pairs of setae; setae on side lobes not visible, each axilla with 1 short seta located apically; scutellum with Sc1 moderate in length and not reaching bases of Sc2, distance between placoid sensilla about  $5\times$  the width of one sensillum; endophragma reaching middle of gastral tergite II; tibial spur of middle leg (Fig. 22)  $0.75\times$  corresponding basitarsus; fore wing (Fig. 24)

broad, disc length  $1.3\times$  disc width; 3 short costal setae along anterior margin of submarginal vein; 2 basal group setae; submarginal vein with 2 setae; marginal vein with 6 setae along its anterior margin, 2 parastigmal setae at its base, fore wing discal setae sparse with a large asetose area under the stigmal vein and posterior margin; marginal fringe  $0.7\times$  disc width; gastral tergite VI with 1 pair of setae between cerci; ovipositor arising at center of tergite IV, length  $1.1\times$  length of tibia of middle leg; valvulae III length  $0.3\times$  that of ovipositor.

*Male.*—Unknown.

*Distribution.*—HAITI.

*Host.*—? *Trialeurodes floridensis*.

*Hispaniola records.*—Known from the type locality only.

*Etymology.*—This species is named in honor of Telemachus, a monk from Asia Minor, who stood alone in opposition to the gladiator games held in Rome in 400 A.D., and whose death on the gladiator field brought about the end of the games in 404 A.D.

*Comments.*—The identity of the whitefly species from which this parasite emerged is uncertain. H. L. Dozier recorded its host as "*Asterochiton bauhiniae*". This name does not appear in Mound and Halsey's 1978 whitefly catalog; therefore, we assume that it is an invalid name. Of the eleven aleyrodine species Mound and Halsey (1978) list as found on *Bauhinia*, only two species, *Trialeurodes floridensis* (Quaintance) and *Bemisia tabaci* (Genn.), are known to occur in the New World. In addition, a search of the collection records stored in the whitefly database of the Florida State Collection of Arthropods, Gainesville, Florida yielded only one species, *Tetraleurodes acaciae* (Quaintance), that has been found on this host in Florida and Puerto Rico. The genus *Tetraleurodes* is very distinct from *Asterochiton*, and it is unlikely that Dozier would have confused these two genera. Steven Nakahara (USDA, personal communication) report-

ed that "there is no slide or dry material of *Asterochiton bauhinae* in the USDA collection, and that this is probably a manuscript name. Most species previously placed in *Asterochiton* in the New World are placed in *Trialeurodes*". Therefore, it is likely that the true identity of the host of this parasite is *Trialeurodes floridensis*.

### *Encarsia variegata* Howard

*Encarsia variegata* Howard 1908:64.

*Trichoporus variegata* (Howard), Dozier 1933:92.

*Hispaniola records*.—HAITI, Port-au-Prince and Source Cazeau, H.L. Dozier, ex *Paraleyrodes* sp. on *Citrus* sp. (Dozier 1933).

### *Eretmocerus pallidus* Dozier

*Eretmocerus pallidus* Dozier 1932b:116.

*Hispaniola record*.—Holotype female, HAITI, Port-au-Prince, 11–17.iv.1931, ex *Tetraleurodes* n. sp. on *Ammonia squamosa* (USNM).

*Comments*.—This species was described from 42 females and is apparently uniparental.

### *Eretmocerus portoricensis* Dozier

*Eretmocerus portoricensis* Dozier 1932b:115; Rose and Zolnerowich 1997:18.

*Hispaniola record*.—DOMINICAN REPUBLIC, ex *Aleurothrixus floccosus* (De Santis 1979).

*Comments*.—This species was described from 45 females and is apparently uniparental.

### *Eretmocerus serius* Silvestri

*Eretmocerus serius* Silvestri 1928:46.

*Hispaniola record*.—Dozier (1932c) reported on the introduction of this species into Haiti in 1931. Specimens were sent from Cuba and released in Port-au-Prince for the control of *Aleurocanthus woglumi* on citrus. A second shipment of this parasite was released in the cities of Petionville, Turgeau and Thor.

*Comments*.—This species has not been

recovered in subsequent collections which suggests that it may have been displaced by *Encarsia perplexa* Huang and Polaszek (=misidentification of *E. opulenta*) and/or *Amitus hesperidum* Silvestri in most areas where *Aleurocanthus woglumi* occurs.

### *Eretmocerus* spp.

*Hispaniola specimens*.—1 female, DOMINICAN REPUBLIC, x.1991, ex ?*Aleurothrixus floccosus* on *Manihot esculenta*; one male specimen, DOMINICAN REPUBLIC, La Vega, Jarabacoa, 10.xii.1995, C. Serra and M. Ortiz, ex *Trialeurodes vaporariorum* and *Bemisia tabaci*, on *Gerbera* sp.; four females, DOMINICAN REPUBLIC, Santiago Province, La Herradura, 18.ii.1995, C. Serra, ex *Bemisia tabaci* complex; HAITI, Damien, 17.vi.1939, ex *Aleurothrixus floccosus* on *Guaiacum officinarum*; 1 female, ex *Aleuroclava minutus* on *Ixora coccinea* in DOMINICAN REPUBLIC, Santiago Province, Santiago, 19.i.1997, C. Serra; DOMINICAN REPUBLIC, Ocoa, Los Ranchitos, Sabine Tappertrzhofen, whitefly on *Solanum melongena*; DOMINICAN REPUBLIC, Ocoa, Las Carreras, Sabine Tappertrzhofen, whitefly on *Solanum melongena*; DOMINICAN REPUBLIC, Azua, Proy, Sabine Tappertrzhofen, whitefly on *Lycopersicon esculentum*.

### Family Eulophidae

#### *Neopomphale aleurothrix* (Dozier)

(Figs. 6, 20)

*Euderomphale aleurothrix* Dozier 1932a:120.

*Neopomphale aleurothrix* (Dozier), Schauff and LaSalle (1994).

*Hispaniola records*.—Holotype female, HAITI, Sarthe, 3–4.ii.1931, ex *Aleurothrixus floccosus* on *Guaiacum officinale*, in USNM; DOMINICAN REPUBLIC, Monte Plata Province, Cruz Verde, 25.ix.1996, C. Serra, ex *Aleurothrixus floccosus* on *Citrus sinensis* and *C. aurantium*.

Table 1. Parasitoids associated with whiteflies in Hispaniola.

---

<i>Aleurocanthus woglumi</i> Ashby: <i>Encarsia perplexa</i> , <i>Eretmocerus serius</i>
<i>Aleuroclava minutus</i> (Singh): <i>Eretmocerus</i> sp.
<i>Aleurodicus dispersus</i> Russell: <i>Encarsia sofia</i>
<i>Aleurodicus</i> sp.: <i>Encarsia lanceolata</i>
<i>Aleuroglandulus malangae</i> Russell: <i>Encarsia hispida</i> , <i>Encarsia portoricensis</i>
<i>Aleuoplatus</i> sp.: <i>Encarsia catherinae</i>
<i>Aleurothrixus floccosus</i> (Maskell): <i>Cales noacki</i> , <i>Encarsia cubensis</i> , <i>Encarsia dominicana</i> , <i>Encarsia haitiensis</i> , <i>Encarsia variegata</i> , <i>Eretmocerus portoricensis</i> , <i>Eretmocerus</i> sp., <i>Neopomphale aleurothrixii</i> , <i>Signiphora townsendi</i> (hyperparasitoid)
<i>Aleurotrachelus trachoides</i> (Back): <i>Encarsia nigricephala</i>
<i>Bemisia tabaci</i> (Genn.)—complex: <i>Encarsia hispida</i> , <i>Encarsia lanceolata</i> , <i>Encarsia tabacivora</i> , <i>Eretmocerus</i> sp., <i>Signiphora aleyrodii</i> (hyperparasitoid)
<i>Bemisia tuberculata</i> Hempel: <i>Encarsia cubensis</i> , <i>Encarsia hispida</i> , <i>Encarsia sofia</i>
<i>Paraleyrodes naranjæ</i> Dozier: <i>Encarsia variegata</i>
<i>Paraleyrodes persæe</i> (Quaintance): <i>Encarsia variegata</i>
<i>Tetraleurodes</i> sp.: <i>Eretmocerus pallidus</i>
<i>Trialeurodes floridensis</i> ? (Quaintance): <i>Encarsia telemachusii</i>
<i>Trialeurodes vaporariorum</i> (Westwood): <i>Amitus fuscipennis</i> , <i>Encarsia formosa</i> , <i>Encarsia hispida</i> , <i>Encarsia tabacivora</i>
Unidentified aleyrodid: <i>Eretmocerus</i> sp.

---

### Family Signiphoridae

#### *Signiphora aleyrodii* Ashmead (Figs. 9, 15, 18)

*Signiphora aleyrodii* Ashmead 1900:412.

*Hispaniola* record.—DOMINICAN REPUBLIC, Azua Province, La Cabuya, S. Tappertzhofen, yellow trap (a hyperparasite through whitefly species).

#### *Signiphora townsendi* Ashmead (Figs. 10, 11)

*Signiphora townsendi* Ashmead 1900:412.

*Hispaniola* record.—DOMINICAN REPUBLIC, Santiago Province, La Herradura, C. Serra 6.vi.95, ex *Aleurothrixus floccosus* on *Psidium guajava* (a hyperparasite).

### Family Platygasteridae

#### *Amitus fuscipennis* MacGown and Nebeker (Fig. 5)

*Amitus fuscipennis* MacGown and Nebeker 1978; Viggiani 1991 (redescription).

*Hispaniola* records.—DOMINICAN REPUBLIC, Cord Central, 17.viii.1972 (MacGown and Nebeker 1978); DOMINI-

CAN REPUBLIC, La Vega Province, Arroyo Prieto, Constanza, 16.v.1995, C. Serra, ex *Trialeurodes vaporariorum* on tomato, *Lycopersicon esculentum*; La Vega Province, Tubagua, C. Serra, 16.v.1995, ex *Bemisia tabaci* complex and/or *Aleurotrachelus* sp., on *Lycopersicon esculentum*; Sabaneta, Jarabacoa, 13.vi.1995, C. Serra, *T. vaporariorum* on *Helianthus annuus*.

### DISCUSSION

The parasitoid complex reared from the various whitefly species in Hispaniola is similar to that found in several other Neotropical countries. Most of the parasitoid species attacking *Aleurothrixus floccosus* have a very narrow host range; most of them are only known from this species and few are known to attack relatively few alternate hosts. *Amitus fuscipennis* occurs in Florida and several Neotropical countries and is often reared from the greenhouse whitefly, *Trialeurodes vaporariorum*, as is *Encarsia formosa* which has been introduced into many areas of the world. *Encarsia hispida*, *E. lanceolata*, *E. nigricephala*, *E. sofia* and *E. tabacivora* are very widespread and are known to parasitize various whitefly hosts; with the exception

of *Encarsia luteola*, which has not been found in Hispaniola, these species comprise the majority of the parasitoids reared from the *Bemisia tabaci* complex in the New World.

### ACKNOWLEDGMENTS

We thank the Fundación de Desarrollo Agropecuario, Inc. (FDA, Sto. Domingo) and the Instituto Superior de Agricultura (ISA, Santiago) for the sponsorship and support of our research project, respectively; S. Tappertzhofen and M. Ortiz who reared or collected some of the parasitoids reported herein; Mike Rose (Montana State University) for his examination and comments on specimens of *Eretmocerus*; and J. Brambila, L. Stange (Florida State Collection of Arthropods Museum) and J. Medal (University of Florida) for their review of this manuscript.

### LITERATURE CITED

- Alvarez, P. A. and A. J. Abud-Antún. 1997. Reporte de República Dominicana. CEIBA (Honduras) 36(1): 39–47.
- Ashmead, W. H. 1900. Genera of the Encyrtinae. Subfamily III—Signiphorinae. *Proceedings of the United States National Museum* 22: 409–412.
- De Santis, L. 1948. Adiciones a la fauna Argentina de afelinidos (Hymenoptera, Chalcidoidea). *Notas del Museo de La Plata, Zoología* 13: 43–48.
- De Santis, L. 1979. Catálogo de lo himenópteros chalcidos de América del Sur de los Estados Unidos. Publicación especial, Provincia Buenos Aires Comisión de Investigación Científica, La Plata, Argentina, 487 pp.
- De Santis, L. 1981. Sobre dos especies de *Encarsia* (Hymenoptera, Aphelinidae) del Brasil parasitoides de *Bemisia tabaci* (Hymenoptera, Aleyrodidae). *Revista Brasileira de Entomologia* 25: 37–39.
- Donis, J. and E. Prophete. 1997. *Las moscas blancas (Homoptera: Aleyrodidae) en Haití: situación actual y manejo*. Memoria: VI Taller Latinoamericano y del Caribe sobre Moscas Blancas y Geminivirus. August 18–19, 1997, JAD-MIP eds., Santo Domingo, República Dominicana, p. 11.
- Dozier, H. L. 1932a. Two undescribed chalcid parasites of the woolly whitefly, *Aleurothrixus floccosus* (Maskell), from Haiti. *Proceedings of the Entomological Society of Washington* 34(7): 118–122.
- Dozier, H. L. 1932b. The identity of certain whitefly parasites of the genus *Eretmocerus* Hald., with description of new species (Hymenoptera: Aphelinidae). *Proceedings of the Entomological Society of Washington* 34(7): 112–118.
- Dozier, H. L. 1932c. Introduction of *Eretmocerus serius* Silv. into Haiti. *Journal of Economic Entomology* 25: 414.
- Dozier, H. L. 1933. Miscellaneous notes and descriptions of chalcidoid parasites (Hymenoptera). *Proceedings of the Entomological Society of Washington* 35(6): 85–100.
- Dozier, H. L. 1937. Descriptions of miscellaneous chalcidoid parasites from Puerto Rico. *Journal of Agriculture of the University of Puerto Rico* 21: 121–135.
- Evans, G. A. and P. A. Pedata. 1997. Parasitoids of *Comstockiella sabalis* (Homoptera: Diaspididae) in Florida and description of a new species of the genus *Coccobius* (Hymenoptera: Aphelinidae). *Florida Entomologist* 80(3): 328–334.
- Evans, G. A. and A. Polaszek. 1997. Additions to the *Encarsia* parasitoids (Hymenoptera: Aphelinidae) of the *Bemisia tabaci*-complex (Hemiptera: Aleyrodidae). *Bulletin of Entomological Research* 87: 563–571.
- Evans, G. A. and A. Polaszek. 1998. The *Encarsia cubensis* species-group (Hymenoptera: Aphelinidae). *Proceedings of the Entomological Society of Washington* 100(2): 222–233.
- Gahan, A. B. 1924. Some new parasitic Hymenoptera with notes on several described forms. *Proceedings of the United States National Museum* 65: 1–23.
- Gahan, A. B. 1931. A new species of *Encarsia* from Cuba (Hymenoptera: Aphelinidae). *Proceedings of the Entomological Society of Washington* 33(5): 121–122.
- Girault, A. A. and A. P. Dodd. 1915. The cane grubs of Australia. *Bulletin of the Bureau of Sugar Experiment Stations, Queensland Division of Entomology* 2: 1–60.
- Grissell, E. E. 1979. The *Prospaltella* of Florida (Hymenoptera: Aphelinidae). *Florida Department of Agriculture and Consumer Services, Entomological Circular No. 203*, 4 pp.
- Hayat, M. 1994. Notes on some genera of the Aphelinidae (Hymenoptera: Chalcidoidea), with comments on the classification of the family. *Oriental Insects* 28: 81–96.
- Hempel, A. 1904. Notas sobre dous inimigos da larangeria. *Boletim da Agricultura 5a serie*, 1: 10–21.
- Heraty, J. M. and A. Polaszek. 2000. Morphometric analysis and description of selected species in the *Encarsia strenua* Group (Hymenoptera: Aphelinidae). *Journal of Hymenoptera Research* 9(1): 42–169.
- Howard, L. O. 1907. New genera and species of Aphelinidae with a revised table of genera. *United States Department of Agriculture Technical Series* 12(4): 69–88.
- Howard, L. O. 1908. Key to the species of *Prospaltella*, with a table of hosts, and descriptions of four new species. *Annals of the Entomological Society of America* 1: 282–283.
- Huang, J. and A. Polaszek. 1998. A revision of the Chinese species of *Encarsia* Forster (Hymenop-

- tera: Aphelinidae): parasitoids of whiteflies, scale insects and aphids (Hemiptera: Aleyrodidae, Diaspididae, Aphidoidea). *Journal of Natural History* 32: 1825–1966.
- MacGown, M. W. and T. E. Nebeker. 1978. Taxonomic review of *Amitus* (Hymenoptera: Proctotrupoidea, Platygasteridae) of the Western Hemisphere. *Canadian Entomologist* 110: 275–283.
- Mercet, R. G. 1931. Notas sobre afelinidos (Hym.Chalc.), 4 nota, *EOS* 7: 395–398.
- Mound, L. A. and S. H. Halsey. 1978. *Whitefly of the World. A Systematic Catalog of the Aleyrodidae (Homoptera) with Host Plant and Natural Enemy Data*, British Museum (Natural History), London, 329 pp.
- Polaszek, A., G. A. Evans and F. D. Bennett. 1992. *Encarsia* parasitoids of *Bemisia tabaci* (Hymenoptera: Aphelinidae, Homoptera: Aleyrodidae): a preliminary guide to identification. *Bulletin of Entomological Research* 82: 375–392.
- Rose, M. and G. Zolnerowich. 1997. *Eretmocerus* Haldeman (Hymenoptera: Aphelinidae) in the United States, with descriptions of new species attacking *Bemisia (tabaci)* complex (Homoptera: Aleyrodidae). *Proceedings of the Entomological Society of Washington* 99(1): 1–27.
- Russell, T. A. 1934. The use of parasites against the palmetto scale. *Agricultural Bulletin, Bermuda Department of Agriculture* 13(11): 81–86.
- Schauff, M. E., G. A. Evans and J. M. Heraty. 1996. A pictorial guide to the species of *Encarsia* (Hymenoptera: Aphelinidae) parasitic on whiteflies (Homoptera: Aleyrodidae) in North America. *Proceedings of the Entomological Society of Washington* 98(1): 1–35.
- Schauff, M. E. and J. LaSalle. 1994. Systematics of the tribe Euderomphalini (Hymenoptera: Eulophidae: parasitoids of whiteflies (Homoptera: Aleyrodidae). *Systematic Entomology* 19: 235–258.
- Serra, C. A. 1992. *Investigations on the use of neem extracts for integrated tomato-pest control in the Dominican Republic*. PhD Thesis, University of Giessen, Wissenschaftlicher Fachverlag, Giessen, Germany, 186 pp. (In German).
- Serra, C. A., M. Ortiz, J. B. Nuñez and P. F. Benoit. 1996. *Estrategias integradas de control del complejo 'moscas blanca geminivirosis' en tomate y el control biológico de Bemisia spp. (Homoptera: Aleyrodidae) en las zonas Norte y Noroeste de la República Dominicana*. 2nd Report to the Fundación de Desarrollo Agropecuario (FDA), Instituto Superior de Agricultura, La Herradura, Santiago, Dominican Republic.
- Silvestri, F. 1928. Contribuzione al conoscenza degli Aleurodidae (Insecta: Hemiptera) viventi su *Citrus* in estremo Orient e dei loro parassiti. II. Descrizione e notizie biologiche dei parassiti di Aleurodiidi viventi su *Citrus*. *Bollettino del Laboratorio di Zoologia Generale e Agraria del R. Istituto Superiore Agrario in Portici* 21: 20–60.
- Trjapitsyn, V. A. and E. R. Cancino. 2000. *Encirtidos (Hymenoptera: Encyrtidae) de importancia agrícola en México*. Serie Publicaciones Científicas CI-DAFF.UAT, 162 pp.
- Viggiani, G. 1985. Notes on a few Aphelinidae, with descriptions of five new species of *Encarsia* Foerster (Hymenoptera: Chalcidoidea). *Bollettino del Laboratorio di Entomologia Agraria 'Filippo Silvestri' di Portici* 42: 81–94.
- Viggiani, G. 1991. Ridescrizione di *Amitus fuscipennis* MacG. and Neb. (Hym: Platygasteridae, parasitoide esotico di *Trialeurodes vaporariorum* (Westwood), con notizie preliminari sulla sua introduzione in Italia. *Redia* 74(1): 177–183.
- Viggiani, G. and M. Carver. 1988. *Cales ochamoplatis* sp. n. (Hymenoptera: Aphelinidae) from Australia. *Journal of the Australian Entomological Society* 27: 43–45.
- Woolley, J. B. 1997. Chapter 5. Aphelinidae. In Gibson, G. A. P., Huber, J. T. and J. B. Woolley (Editors). *Annotated Keys to the Genera of Nearctic Chalcidoidea (Hymenoptera)*. NRC Research Press, Ottawa, Ontario, Canada, 794 pp.

## Survey of the Parasitic Hymenoptera on Leafminers in California

M. W. GATES, J. M. HERATY, M. E. SCHAUFF, D. L. WAGNER, J. B. WHITFIELD, AND  
D. B. WAHL

(MWG, MES) Systematic Entomology Lab., PSI, USDA-ARS, National Museum of Natural History, NHB 168, Washington, DC 20560, USA, MWG email: mgates@sel.barc.usda.gov, MES email: mschauff@sel.barc.usda.gov; (JMh) Department of Entomology, University of California, Riverside, CA 92521, USA, email: john.heraty@ucr.edu; (DLW) Department of Ecology and Evolutionary Biology, University of Connecticut, Storrs, CT 06269, USA, email: pwagner@uconnvm.uconn.edu; (JBW) Department of Entomology, University of Illinois, Urbana, IL 61801, USA, email: jwhitfie@life.uiuc.edu; (DBW) American Entomological Institute, 3005 SW 56th St., Gainesville, FL 32608, USA, email: dr.x@msn.com

---

*Abstract.*—Hymenopteran parasitoids of leafminers in California are reviewed and an illustrated key to 44 genera (except Braconidae) is presented. Leafminer surveys conducted by Michael Gates (MWG) and John Heraty (JMh) between 1996 and 1999, sought to assess native parasitoid fauna in preparation for the anticipated arrival of the citrus leafminer (CLM), *Phyllocnistis citrella* Stainton, in California. These records are augmented with leafminer parasitoid rearing records of David Wagner (DLW) and Jim Whitfield (JBW) accumulated between 1979–1986. Comparison of California parasitoid fauna with CLM parasitoids from other regions would indicate which native species are likely to shift onto CLM as potential autochthonous biocontrol agents. Members of the families Eulophidae, Encyrtidae, Pteromalidae, Chalcididae, Eurytomidae, Eupelmidae, Torymidae (Chalcidoidea), Bethyridae (Chrysidoidea), Braconidae, and Ichneumonidae (Ichneumonoidea) were recovered, with >80% of specimens reared belonging to Eulophidae.

---

This project was initially conceived and funded as a preparatory step in addressing the inevitable establishment of the citrus leafminer (CLM), *Phyllocnistis citrella* Stainton, (Lepidoptera: Gracillariidae: Phyllocnistinae) into California citrus. Eventually, the project expanded to document the identities of not only leafminers and their parasitoids reared by MWG and JMh (see below) from citrus growing regions and native biotic zones of southern California, but also numerous specimens reared by DLW and JBW, primarily from central and northern California between 1979–1986.

Parasitoids, particularly Chalcidoidea, of leafmining insects are usually generalists with respect to host or plant taxon with which they are associated (Askew and Shaw 1974). The same appears true with Ichneumonoidea, although the Bra-

conidae appear to exhibit more specialization for a given host taxon (Shaw and Askew 1976). Additionally, idiobionts (host permanently paralyzed or killed at time of parasitoid attack) are often generalists while koinobionts (host paralyzed only during oviposition by parasitoid) are primarily specialists with Ichneumonoidea containing a higher proportion of koinobionts than Chalcidoidea (see discussion in Godfray (1994)). Those ichneumonids attacking leafminers are often facultative and, like Chalcidoidea, relatively unspecialized (Shaw and Askew 1976). Most leafminer parasitoids are niche specialists rather than host specialists and factors other than host taxonomy directly affect the degree of specialization displayed by leafminer parasitoids. These factors include host plant (phenology, chemistry, etc.), leafmine location (ab- or adaxial leaf

surface) or mine structure (tentiform, serpentine, blotch, etc.) (Askew and Shaw 1974).

The eulophid *Sympiesis sericeicornis* Nees (Hymenoptera: Eulophidae) is found on *Phyllonorycter* spp. (including *P. blancardella*) (Lepidoptera: Gracillariidae) throughout the Holarctic region (Bouček 1959a, Miller 1970, Doganlar 1980) and dominates the chalcid fauna in southern Ontario (Johnson et al. 1976, Hagley 1985). However, it is replaced in dominance by *Sympiesis marylandensis* Girault outside of Ontario (Pottinger and Leroux 1971, Maier 1984a, b, Ridgway and Mahr 1985). Maier (1988b) provided further evidence of niche (but not host) specialization during an investigation of the gracillariid hosts of *S. marylandensis* in New England, an important parasitoid of the two apple pests, *P. blancardella* and *P. crataegella*. He affirmed that *S. marylandensis* prefers abaxial mines, attacking 33 gracillariid leafminer species on 49 plant species (primarily trees, but also shrubs and herbs). Further, many agriculturally important parasitoids (including *S. marylandensis*) occur on congeneric leafminers of native cherry trees and serve as another parasitoid reservoir (Maier 1988a). Both examples illustrate the importance of native plants and leafminers as reservoirs for parasitoids important in biological control.

This study was undertaken to assess native leafminer parasitoid populations in southern California and to determine if any parasitoid species supported by native leafminers might shift to and provide fortuitous biocontrol of CLM after its arrival in California. The CLM is native to Southeast Asia, with populations extending west to the Saudi Peninsula and east to Japan (Heppner 1993). CLM spread to Australia and Africa by the early 18th century and by 1993 colonized most citrus-growing regions of the Old World. Since 1993, when CLM was first detected in Florida, it has spread throughout the Neotropics from Argentina and Mexico to

southern Arizona (Heppner 1993, Knapp et al. 1995). CLM was notably absent from California citrus until 2000 (Guillén et al. 2001), when it was detected in the Imperial Valley.

Utilization of native parasitoids in the biocontrol of introduced pests is not a new concept (LaSalle and Gauld 1993, LaSalle 1993) and has many potential advantages over importing exotic parasitoids from a pest's native range: 1) the need for time-consuming and expensive foreign exploration is eliminated, 2) importation and quarantine protocols become unnecessary, 3) potential detrimental impacts of exotic parasitoid introduction upon non-target leafminers and their parasitoids is eliminated. This reservoir of native parasitoids, which can provide control of exotic pests, is one of the benefits of preserving biodiversity via habitat conservation (see discussion and references in LaSalle and Gauld 1993, LaSalle 1993, LaSalle and Peña 1997). Thus, preserving native habitats with their resident potential biocontrol agents can yield economic benefits as it pertains to a program of sustainable agriculture (LaSalle and Gauld 1993, LaSalle 1993).

Previously unnoticed native parasitoids switching to provide control of an introduced pest has been documented. Rose and DeBach (1982, 1992) found that *Eretmocerus debachi* Rose and Rosen (Hymenoptera: Aphelinidae) effectively controlled the bayberry whitefly (*Parabemisia myricae* (Kuwana) (Hemiptera: Aleyrodidae)) introduced into southern California from eastern Asia. Subsequent releases of *E. debachi* successfully controlled *P. myricae* in Israel and Turkey (Rose and DeBach 1992). This example highlights not only the importance of native parasitoids in fortuitous biocontrol, but also their potential for introduction as a non-native agent in other parts of the world. In surveying native parasitoids attacking CLM in Florida, eight genera and at least eight species were recovered from CLM, 87.4% of these

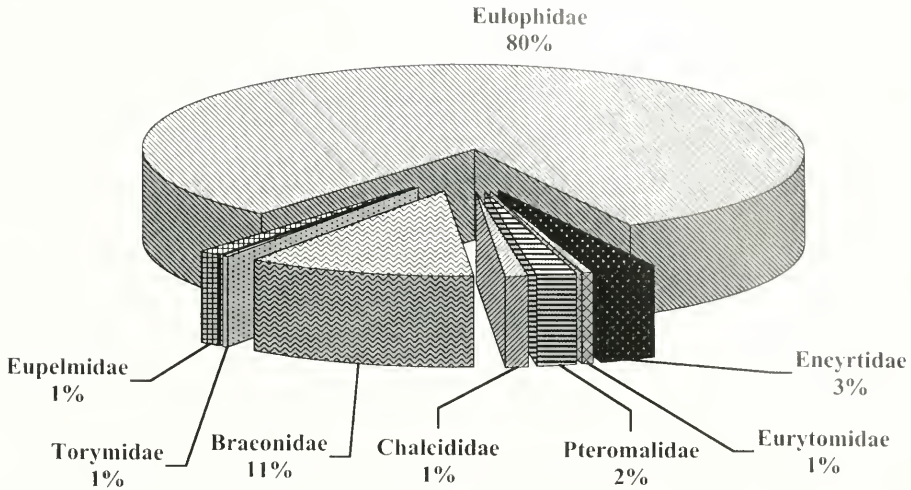

Fig. A. Proportion of chalcidoid families reared from leafminers based on number of parasitoids recovered.

belonging to Eulophidae (Peña et al. 1996). However, only *Pnigalio minio* (Walker) was present year-round; it accounted for 69–88% of all parasitoids reared between 1993–1995. Additionally, four of the same eulophid genera present in Florida were also recovered in south Texas (Legaspi and French 1996) from CLM. Survey results from California recovered all of the same genera documented from CLM in many parts of the world. Further, a new species of native eulophid parasitoid, *Cirrospilus coachellae* Gates (Gates 2000), attacks the citrus peelminer (CPM), *Marmara gulosa* Guillén and Davis (Lepidoptera: Gracillariidae) (Guillén et al. 2001), a cyclical pest of grapefruit. This eulophid has been demonstrated to be effective in reducing CPM populations in the Coachella Valley in Southern California. Colonization of *C. coachellae* is underway at the University of California at Riverside in preparation for use against CLM (Guillén, pers. comm.) and this wasp has been released against CPM in Kern County, CA where CPM has recently become problematic.

Finally, an interesting study of alternative hosts for CLM parasitoids found on the native flora in and around citrus groves in the Mediterranean region (Mas-

sa et al. 2001) indicated that presumed specialist parasitoids were in fact generalists which attacked non-target hosts. Thus, exotic released parasitoids might displace native parasitoids through direct competition, reducing the diversity of the native parasitoid resource. Little definitive documentation exists, but Bennett (1993) provides information on several biocontrol agents that have been released and appear to have displaced native parasitoids, though the evidence is not incontrovertible. A better example is presented by Viggiani (1994) in which the native parasitoid complex of the viburnum whitefly, *Aleurotuba jelineki* (Frauenfeld) (Hemiptera: Aleyrodidae), was completely displaced in many areas in southern Italy by *Cales noacki* Howard, introduced against the woolly whitefly.

Over 80 species of parasitoids (both native and introduced species) have been recorded from CLM worldwide and appear to provide effective control in many cases (Schauff et al. 1998 and references therein). Our current study recovered Eulophidae from >80% of the 5,400 samples reared by MWG and JMH (Fig. A) with the next-largest proportion of parasitoids belonging to Braconidae. When parasitoid species accumulation is calculated across

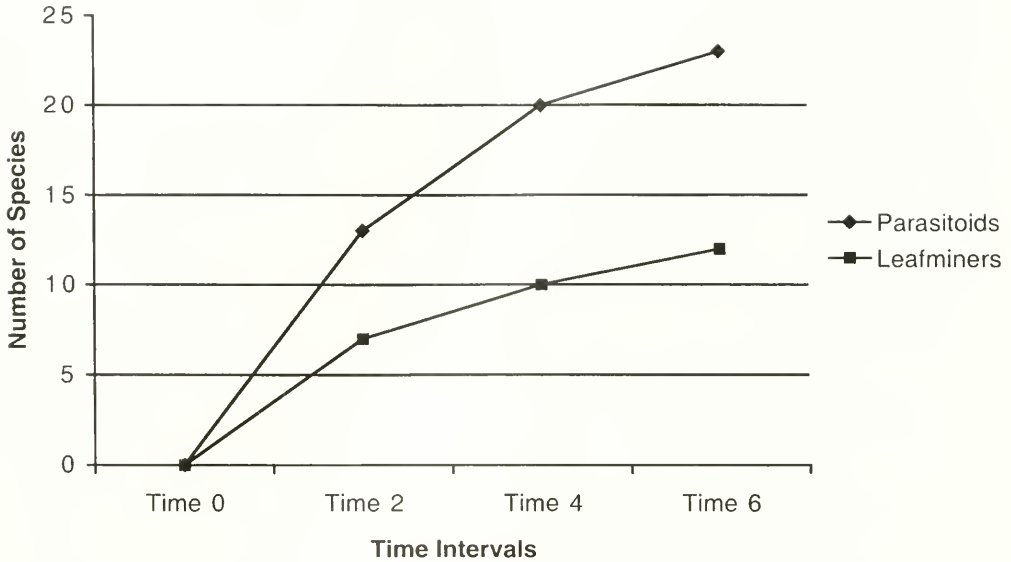

Fig. B. Species accumulation of leafminers and their parasitoids (One time interval = 6 months).

sampling time periods (Fig. B), it appears that more species remain to be recovered with continued sampling. However, these curves are based upon an arbitrary division of the sampling period of MWG/JMH into six-month blocks and serve only as a gross estimate of accumulation. Summaries of the rearing data of DLW and JBW are not included as many reared chalcidoid leafminer parasitoids were not preserved and are no longer retrievable by the authors and counts of numbers and diversity of parasitoid species would likely underestimate actual values.

#### MATERIALS AND METHODS

Included in Table 1 are all records of (where determined) plant hosts, leafminer hosts and parasitoids of those leafminers in California which were recovered during this study. Microhymenopteran parasitoid families and genera are summarized in Table 3, with genera of Braconidae designated by letters as they are not treated herein. An ancillary goal of this project is to allow comparisons with similar studies to be made with respect to which parasitoid genera and species are typically recov-

ered from native leafminers, and also, which of those parasitoids are documented from CLM or could be considered likely to attack CLM.

Protocols of MWG and JMH for rearing individual leafminers are detailed below. Leafminers in their host plants were collected from field localities and placed into brown paper bags that were placed into 1 gallon Zip-Loc<sup>®</sup> bags labeled with the locality information. This system allowed for maintenance of high humidity while inhibiting significant accumulation of condensation inside of each sample bag. Samples so prepared could be stored up to 4 days in a refrigerator with minimal loss of plant quality, which maximized leafminer and parasitoid survival. From these plant samples, individual leafmines were excised and placed into separate 4-dram shell vials and each vial was tightly plugged with cotton. Each vial received a unique alphanumeric code that was placed in the vial with the sample and each code was recorded in a project notebook. Vials were then inserted into the 1 cm<sup>2</sup> spaces in plastic grids designed to fit fluorescent lighting fixtures common in

Table 1. Hymenopterous parasitoids reared from native leafminers in California.

Plant family/species	Guild	Leafminer	Parasitoids
<b>Anacardiaceae</b>			
<i>Rhus integrifolia</i> (Nutt.)	USS <sup>1</sup>	<i>Stigmella rhoifoliella</i> (Braun)	<i>Closterocerus utahensis</i> Crawford†
<i>Rhus diversiloba</i> T. and G.	LSBM/LR	<i>Caloptilia diversilobiella</i> Opler	<i>Sympiesis marylandensis</i> Girault, <i>Goniozus</i> sp., <i>Pholetesor bedelliae</i> (Viereck), <i>Pholetesor salicifoliellae</i> (Mason), <i>Bathylthrix latifrons</i> (Cushman)‡
<i>Rhus ovata</i> S. Watson	USBM/LR	<i>Caloptilia ovatiella</i> Opler	<i>Pholetesor salalicus</i> (Mason)‡
<b>Asteraceae</b>			
<i>Arnica parryi</i> A. Gray	LSBM	<i>Acrocercops</i> sp.	<i>Mesochorus</i> sp.‡
<i>Artemisia douglasiana</i> Besser	USS/B	Unknown	<i>Chrysocharis ainsliei</i> Crawford, <i>Aprostocetus</i> sp.†
<i>Artemisia douglasiana</i> Besser	CS/E	<i>Bucculatrix</i> sp.	<i>Paroligoneurus</i> sp., <i>Pholetesor</i> n. sp. 4‡
<i>Artemisia douglasiana</i> Besser	LSBM	<i>Cremastobombycia</i> n. sp.	<i>Apanteles</i> sp., <i>Colastes</i> sp.‡
<i>Artemisia suksdorfi</i> Piper		"leaf miner"	<i>Pholetesor salalicus</i> (Mason)‡
<i>Artemisia tridentata</i> Nutt.	CS/E	<i>Bucculatrix</i> sp.	<i>Deuterixys pacifica</i> Whitfield, <i>Gelis</i> sp. 3 (fem), <i>Gelis</i> sp. 4 (male)‡
<i>Artemisia tridentata</i> Nutt.	CS/E	<i>Bucculatrix</i> sp.	<i>Pholetesor bedelliae</i> (Viereck)‡
<i>Artemisia</i> sp.		?Agromyzidae	<i>Brachymeria</i> sp.†
<i>Artemisia</i> sp.	LSBM	<i>Cremastobombycia</i> sp.	<i>Pnigalio</i> sp.‡
<i>Aster chilensis</i> Nees	FDBM	<i>Coleophora</i> sp.	<i>Mesopolobus</i> sp.‡
<i>Aster</i> sp.	USS	<i>Calycomyza</i> sp., <i>Liriomyza</i> sp.	<i>Diglyphus</i> sp.‡
<i>Aster</i> sp.	FDBM	<i>Tischeria</i> sp.	<i>Pnigalio flavipes</i> (Ashmead), <i>Aprostocetus</i> sp., <i>Chrysocharis</i> sp., <i>Sympiesis stigmata</i> Girault, <i>Apanteles</i> sp., <i>Zagrammosoma mirum</i> Girault‡
<i>Baccharis pilularis</i> DC.	CS/E	<i>Bucculatrix variabilis</i> Braun	<i>Pholetesor</i> n. sp. 4, <i>Pholetesor</i> n. sp. 2, <i>Deuterixys pacifica</i> Whitfield, <i>Stiropius californicus</i> Whitfield‡
<i>Baccharis pilularis</i> DC.	CS/E	<i>Bucculatrix dominatrix</i> Rubinoff and Osborne	<i>Pholetesor</i> n. sp. 2‡
<i>Baccharis pilularis</i> DC.	LSBM	<i>Cremastobombycia</i> sp.	<i>Apanteles</i> sp.‡
<i>Baccharis salicifolia</i> (R. Lopez and Pavón)	USS	<i>Bucculatrix</i> sp. or Agromyzidae	<i>Sympiesis marylandensis</i> Girault, <i>Chrysocharis ainsliei</i> Crawford†
<i>Baccharis</i> sp.	CS/E	<i>Bucculatrix</i> sp.	<i>Gelis</i> sp. 6 (fem), <i>Gelis</i> sp. 1 (male), <i>Gelis</i> sp. 2 (fem)‡
<i>Baccharis</i> sp.	CS/E	<i>Bucculatrix</i> ? <i>variabilis</i> Braun	<i>Gelis</i> sp. 1 (male) <i>Gelis</i> sp. 2 (fem)‡
<i>Brickellia</i> sp.	FDBM	<i>Tischeria</i> sp.	<i>Apanteles</i> sp.‡
<i>Bidens pilosa</i> L.	USS	<i>Liriomyza</i> sp.	<i>Diglyphus begini</i> (Ashmead), <i>Closterocerus cinctipennis</i> Ashmead, <i>C. utahensis</i> Crawford, <i>Chrysocharis</i> sp.†
<i>Cirsium vulgare</i> (Savi)	USS	<i>Liriomyza</i> sp.	<i>Closterocerus</i> sp., <i>Closterocerus</i> poss. <i>submutica</i> Graham†
<i>Encelia californica</i> Nutt.	CS/E	<i>Bucculatrix</i> sp.	<i>Apanteles</i> sp.‡

Table 1. Continued.

Plant family/species	Guild	Leafminer	Parasitoids
<i>Encelia californica</i> Nutt.	LSBM	<i>Acrocercops</i> sp.	<i>Apanteles</i> sp.‡
<i>Encelia farinosa</i> Gray	USS/B	<i>Calycomyza enceliae</i> Spencer	<i>Pnigalio maculipes</i> (Crawford)†
<i>Gnaphalium</i> sp.	?LSBM	? <i>Cremastobomyia</i> sp.	<i>Dolichogenidea</i> sp.‡
<i>Grindelia</i> sp.	USBM	<i>Cremastobomyia grindeliella</i> Wlsm.	<i>Pnigalio</i> ?sp., <i>Aprostocetus</i> sp.‡
<i>Helianthus annuus</i> L.	USS	<i>Calycomyza enceliae</i> Spencer	<i>Chrysocharis ainsliei</i> Crawford, <i>Pnigalio flavipes</i> (Ashmead)†
<i>Iva axillaris</i> Pursh.	CS/E	<i>Bucculatrix</i> sp.	<i>Deuterixys pacifica</i> Whitfield‡
<i>Silybum marianum</i> Gaertn.	CS/B	<i>Liriomyza</i> sp.	<i>Diglyphus begini</i> (Ashmead)†
<i>Solidago</i> sp.	LSBM	<i>Acrocercops</i> sp.	<i>Pholetesor bedelliae</i> (Viereck)‡
<i>Sonchus oleraceus</i> L.	CS	<i>Chromatomyia syngenesiae</i> Hardy	<i>Pediobius acantha</i> (Walker), <i>Pnigalio coloni</i> (Girault), <i>Chrysocharis ainsliei</i> Crawford, <i>Diglyphus begini</i> (Ashmead), <i>Closterocerus</i> sp.†
<i>Venegasia carpesioides</i> DC	CS	Agromyzidae	<i>Colastes</i> n. sp., <i>Diglyphus begini</i> (Ashmead)†
<i>Wyethia mollis</i> A. Gray	CS/E	<i>Bucculatrix divisa</i> Braun	<i>Pholetesor bedelliae</i> (Viereck)‡
<i>Xanthium strumarium</i> L.	USS	<i>Calycomyza</i> sp.	<i>Thimodytes caroticus</i> Heydon, <i>Pnigalio boharti</i> Yoshimoto, <i>Chrysocharis ainsliei</i> Crawford, <i>Halticoptera</i> sp., <i>Sympiesis marylandensis</i> Girault†
<b>Berberidaceae</b>			
<i>Berberis pinnata</i> Lagasca	USS	<i>Stigmella</i> sp.	<i>Colastes</i> sp.‡
<b>Betulaceae</b>			
<i>Alnus rhombifolia</i> Nutt.	USS/B		<i>Closterocerus utahensis</i> Crawford†
<i>Alnus rubra</i> Bong.	USBM	<i>Phyllonorycter incana</i> (Walsm.)	<i>Pholetesor salicifoliellae</i> (Mason), <i>Mesochorus</i> sp., <i>Pnigalio</i> sp.‡
<i>Alnus tenuifolia</i> Nutt.	USBM or LSBM/LR	<i>Caloptilia alnivorella</i> (Chambers)	<i>Apanteles</i> sp., <i>Pholetesor salicifoliellae</i> (Mason)‡
<i>Alnus tenuifolia</i> Nutt.	USBM or LSBM	<i>Phyllonorycter</i> sp.	<i>Colastes</i> sp.‡
<i>Betula fontinalis</i> Sargent	LSBM>>LS	<i>Parornix</i> sp.	<i>Pholetesor salalicus</i> (Mason), <i>Pholetesor salicifoliellae</i> (Mason)‡
<i>Corylus cornuta</i> Marsh.	LSBM	<i>Phyllonorycter</i> sp.	<i>Rhysipolis decorator</i> (Haliday)‡
<b>Bignoniaceae</b>			
<i>Chilopsis linearis</i> (Cav.)	USS/B		<i>Closterocerus utahensis</i> Crawford†
<b>Buxaceae</b>			
<i>Simmondsia chinensis</i> (Link.)	CB	? <i>Periploca</i> sp.	<i>Bassus calcaratus</i> (Cresson), <i>Trichomalopsis</i> sp., <i>Sympiesis stigmata</i> Girault, <i>Sympiesis ?acrobasidis</i> Miller, <i>Sympiesis ?sericeicornis</i> (Nees)†
<b>Brassicaceae</b>			
<i>Hirschfeldia incana</i> (L.)	USS	<i>Liriomyza</i> sp.	<i>Colastes</i> n. sp., <i>Diglyphus begini</i> (Ashmead), <i>Euderus</i> sp., <i>Chrysocharis</i> sp.†

Table 1. Continued.

Plant family/species	Guild	Leafminer	Parasitoids
<b>Caprifoliaceae</b>			
<i>Lonicera hispidula</i> Douglas	FDBM	<i>Perittia passula</i> Kaila	<i>Apanteles</i> sp.‡
<i>Lonicera hispidula</i> Douglas	LSBM	<i>Phyllonorycter</i> sp.	<i>Colastes</i> sp.‡
<i>Lonicera</i> sp.	LSBM	<i>Phyllonorycter</i> sp.	<i>Apanteles</i> sp.‡
<i>Lonicera subspicata</i> H and A or <i>Symphoricarpos mollis</i> Nutt.	USS/B	Agromyzidae	<i>Diglyphus begini</i> (Ashmead)†
<i>Symphoricarpos mollis</i> Nutt.	FDBM	<i>Perittia</i> sp.	<i>Apanteles</i> sp.‡
<i>Symphoricarpos mollis</i> Nutt.	LSBM	<i>Phyllonorycter</i> sp.	<i>Apanteles</i> sp., <i>Colastes</i> sp., <i>Parahormius</i> sp.‡
<i>Symphoricarpos albus</i> (L.)	LSBM	<i>Phyllonorycter</i> sp.	<i>Pholetesor salicifoliellae</i> (Mason)‡
<i>Symphoricarpos</i> sp.	LSBM	<i>Phyllonorycter</i> sp.	<i>Encratocla</i> sp., <i>Pimpla</i> sp., <i>Gelis</i> sp. 2 (fem)‡
<b>Convolvulaceae</b>			
<i>Convolvulus arvensis</i> L.	FDBM	<i>Bedellia sommulentella</i> (Zeller)	<i>Parahormius</i> sp., <i>Gelis</i> sp. 2 (fem), <i>Pholetesor bedelliae</i> (Viereck)‡
<b>Cornaceae</b>			
<i>Cornus</i> sp.	FDBM	<i>Autispila aurirubra</i> Braun	<i>Pnigalio flavipes</i> (Ashmead), <i>Pediobius albipes</i> (Provancher), <i>Colastes</i> sp.‡
<b>Cucurbitaceae</b>			
<i>Cucumis melo</i> L.	USS/B	<i>Liriomyza sativae</i> Blanchard	? <i>Neochrysocharis</i> sp.†
<i>Cucurbita foetidissima</i> HBK	USS/B	Agromyzidae	<i>Dialinopsis callichroma</i> Crawford, <i>Diglyphus begini</i> (Ashmead), <i>Neochrysocharis diastatae</i> (Howard), <i>Neochrysocharis arizonensis</i> (Crawford), <i>Thionodytes caroticus</i> Heydon†
<b>Cyperaceae</b>			
<i>Carex</i> sp.	USS/FDBM	<i>Elachista</i> sp.	<i>Pholetesor bedelliae</i> (Viereck), <i>Colastes</i> sp.‡
<b>Datiaceae</b>			
<i>Datisca glomerata</i> (Presl.)	CS	<i>Liriomyza</i> sp.	<i>Pnigalio coloni</i> Girault, <i>Chrysocharis oscinidis</i> Ashmead, <i>Halticoptera</i> sp., <i>Spalangia</i> sp., <i>Gonalocerus</i> (?), <i>Encyrtinae</i> , <i>Closterocerus cincinnatus</i> Girault, <i>Brasema</i> ? <i>macrocarpa</i> (Ashmead)†
<b>Ericaceae</b>			
<i>Arbutus menziesii</i> Pursh.	USS/FDBM	<i>Coptodisca arbutiella</i> Busck	<i>Closterocerus trifasciatus</i> Westw., <i>Sympiesis</i> sp., <i>Chrysocharis</i> sp., <i>Mirax ectoedemiae</i> (Rohwer)†
<i>Arbutus menziesii</i> Pursh.	USS	<i>Marmara arbutiella</i> Busck	<i>Apanteles</i> sp., <i>Mirax ectoedemiae</i> (Rohwer)†
<i>Arbutus menziesii</i> Pursh.	LSBM or USBM	<i>Phyllonorycter arbutusella</i> Braun	<i>Sympiesis stigmata</i> Girault, <i>Chrysocharis</i> sp., <i>Neochrysocharis</i> ?sp., <i>Achrysocharoides</i> ? <i>woelferi</i> (Delucchi)‡
<i>Arctostaphylos columbiana</i> Piper	USBM or LSBM	<i>Phyllonorycter</i> ? <i>manzanitae</i> Braun	<i>Colastes</i> sp., <i>Pholetesor salalicus</i> (Mason)‡

Table 1. Continued.

Plant family/species	Guild	Leafminer	Parasitoids
<i>Arctostaphylos glauca</i> Lindl.	USS	?Gelechiidae	<i>Torymus</i> sp., <i>Eupelmus</i> sp.†
<i>Arctostaphylos manzanita</i> C. Parry	CS/FDBM	<i>Coptodisca ?arbutiella</i> Busck	<i>Mirax ectoedemiae</i> (Rohwer)‡
<i>Arctostaphylos patula</i> E. Greene	USS	<i>Marmara arbutiella</i> Busck	<i>Mirax ectoedemiae</i> (Rohwer)‡
<i>Arctostaphylos stansfordiana</i> C. Parry	CS/FDBM	<i>Coptodisca ?arbutiella</i> Busck	<i>Mirax ectoedemiae</i> (Rohwer)‡
<i>Arctostaphylos virgata</i> Eastw.	CS/FDBM	<i>Coptodisca ?arbutiella</i> Busck	<i>Mirax ectoedemiae</i> (Rohwer)‡
<i>Arctostaphylos virgata</i> Eastw.	USBM or LSBM	<i>Phyllonorycter manzanitae</i> Braun	<i>Mirax ectoedemiae</i> (Rohwer)‡
<i>Arctostaphylos</i> sp.	CS/FDBM	<i>Coptodisca ?arbutiella</i> Busck	<i>Mirax ectoedemiae</i> (Rohwer)‡
<i>Arctostaphylos</i> sp.	USBM or LSBM	<i>Phyllonorycter manzanitae</i> Braun	<i>Apanteles</i> sp., <i>Neochrysocharis</i> sp., <i>Sympiesis stigmata</i> Girault, <i>Pnigalio flavipes</i> (Ashmead), <i>Mirax ectoedemiae</i> (Rohwer), <i>Pholetesor salalicus</i> (Mason)‡
<i>Arctostaphylos</i> sp.	CS/FDBM	<i>Coptodisca ?arbutiella</i> Busck	<i>Chrysocharis</i> sp.‡
<i>Gaultheria shallon</i> Pursh.	USBM	<i>Cameraria gaultheriella</i> Wlsm.	<i>Ageniaspis bicoloripes</i> (Girault), <i>Chrysocharis</i> sp., <i>Colastes</i> sp., <i>Pholetesor salalicus</i> (Mason), <i>Pholetesor</i> n. sp. 3‡
<i>Kalmia polifolia</i> Wangenh.	LSBM	<i>Phyllonorycter</i> n. sp.	<i>Pholetesor salalicus</i> (Mason)‡
<i>Ledum glandulosum</i> Nutt.	USBM	<i>Phyllonorycter ledella</i> Wlsm.	<i>Achrysocharoides ?zwoelferi</i> (Delucchi), <i>Colastes</i> sp.‡
<i>Rhododendron occidentale</i> (Torrey and Gray)	CS/FDBM	<i>Lyonetia candida</i> Braun	<i>Pnigalio flavipes</i> (Ashmead)‡
<i>Rhododendron occidentale</i> (Torrey and Gray)	LSBM/LS	<i>Caloptilia ferruginella</i> (Braun)	<i>Pholetesor salalicus</i> (Mason), <i>Pholetesor salicifoliellae</i> (Mason)‡
<i>Rhododendron</i> (ornamentals)	LSBM/LS	<i>Caloptilia azaleella</i> (Braun)	<i>Pholetesor salalicus</i> (Mason)‡
<i>Rhododendron</i> sp.	CS/FDBM	<i>Lyonetia latistrigella</i> Wlsm.	<i>Closterocerus trifasciatus</i> Westwood, <i>Sympiesis marylandensis</i> Girault‡
<i>Vaccinium ovatum</i> Pursh.	USBM	<i>Cameraria nemoris</i> (Walsm.)	<i>Colastes</i> sp., <i>Pholetesor salalicus</i> (Mason)‡
<i>Vaccinium</i> sp.	USBM	<i>Cameraria nemoris</i> (Walsm.)	<i>Achrysocharoides ?zwoelferi</i> (Delucchi)‡
<b>Fabaceae</b>			
<i>Lathyrus</i> sp.	LSBM	<i>Phyllonorycter</i> nr <i>memorabilis</i> (Wlsm.) or <i>Protolithocolletis lathyri</i> Braun	<i>Pholetesor salicifoliellae</i> (Mason), <i>Colastes</i> sp.‡
<i>Lathyrus</i> sp.	B		<i>Gelis</i> sp. 3 (male)‡
<i>Lotus scoparius</i> (Nutt.)	SSM	<i>Microcalyptis lotella</i> Wagner	<i>Chelonus</i> sp., <i>Mirax ectoedemiae</i> (Rohwer)‡
<i>Lotus</i> sp.		"leafminer"	<i>Parahormius</i> sp.‡
<i>Medicago sativa</i> L.	CS	<i>Liriomyza sativae</i> Blanchard	<i>Diailinopsis callichroma</i> Crawford, <i>Closterocerus cincinnatus</i> Girault, <i>C. utahensis</i> Crawford, <i>Achrysocharoides ?zwoelferi</i> (Delucchi), <i>Neochrysocharis arizonensis</i> (Crawford), <i>Chrysocharis</i> sp.†

Table 1. Continued.

Plant family/species	Guild	Leafminer	Parasitoids
<b>Fagaceae</b>			
<i>Chrysolepis chrysophalla</i> (Hook.)	LSBM	<i>Phyllonorycter</i> n. sp.	<i>Chrysocharis</i> sp., <i>Phigalio</i> sp., <i>Pholetesor salalicus</i> (Mason)‡
<i>Chrysolepis chrysophalla</i> (Hook.)	USBM	<i>Cameraria tildenii</i> Opler and Davis	<i>Pholetesor salalicus</i> (Mason)‡
<i>Chrysolepis sempervirens</i> (Hook.)	USBM	<i>Cameraria sempervirensella</i> Opler and Davis	<i>Pholetesor salalicus</i> (Mason)‡
<i>Chrysolepis sempervirens</i> (Kellogg)	LSBM	<i>Phyllonorycter</i> n. sp.	<i>Pholetesor salalicus</i> (Mason)‡
<i>Lithocarpus densiflorus</i> Hook and Arn.	LSBM	<i>Phyllonorycter</i> n. sp.	<i>Pholetesor salalicus</i> (Mason)‡
<i>Lithocarpus densiflorus</i> Hook and Arn.	USS	<i>Stigmella</i> sp.	<i>Mirax ectoedemiae</i> (Rohwer), <i>Paradelius rubra</i> Whitfield‡
<i>Quercus agrifolia</i> Nee	USBM	<i>Acrocercops insulariella</i> Opler	<i>Pholetesor salalicus</i> (Mason)‡
<i>Quercus agrifolia</i> Nee	CS/E	<i>Bucculatrix albertiella</i> Busck	<i>Cantharoctonus</i> sp., <i>Denterixys quercicola</i> Whitfield, <i>Pholetesor bucculatricis</i> (Muesebeck), <i>Pholetesor</i> n. sp. 4, <i>Gelis</i> sp. 2 (fem), <i>Gelis</i> sp. 4 (fem), <i>Gelis</i> sp. 5 (fem), <i>Gelis</i> sp. 1 (male), <i>Gelis</i> sp. 4, <i>Gelis</i> sp. 5 (male)‡
<i>Quercus agrifolia</i> Nee	LSBM or USBM/LS	<i>Caloptilia reticulata</i> (Braun)	<i>Dolichogenidea</i> sp., <i>Campoplex</i> sp.‡
<i>Quercus agrifolia</i> Nee	USBM	<i>Cameraria agrifoliella</i> (Braun)	<i>Pholetesor salalicus</i> (Mason)‡
<i>Quercus agrifolia</i> Nee	USS	<i>Stigmella variella</i> (Braun)	<i>Mirax ectoedemiae</i> (Rohwer), <i>Paradelius rubra</i> Whitfield, <i>Parahormius</i> sp.‡
<i>Quercus agrifolia</i> Nee.	USS	<i>Stigmella ?variella</i> (Braun)	<i>Dolichogenidea tischeriae</i> (Viereck)‡
<i>Quercus agrifolia</i> Nee.	USBM	<i>Cameraria agrifoliella</i> (Braun)	<i>Sympiesis marylandensis</i> Girault, <i>Phigalio flavipes</i> (Ashmead), <i>Cirrospilus</i> sp., <i>Aprostocetus</i> sp.‡
<i>Quercus agrifolia</i> Nee	USBM	<i>Cameraria wislizeniella</i> Opler	<i>Encyrtinae</i> , <i>Chrysocharis</i> sp., <i>Sympiesis marylandensis</i> Girault‡
<i>Quercus agrifolia</i> Nee	USBM or LSBM/LR	<i>Caloptilia</i> sp.	<i>Campoplex</i> sp., <i>Scambus hirticauda</i> (Provancher)‡
<i>Quercus agrifolia</i> Nee	LSBM	<i>Phyllonorycter</i> sp.	<i>Sympiesis</i> sp., <i>Chrysocharis</i> sp., <i>Phigalio levis</i> Yoshimoto, <i>Horismeneus fraternus</i> (Fitch), <i>Agonaspis bicoloripes</i> (Girault)‡
<i>Quercus agrifolia</i> Nee	MVT/FDBM	<i>Neurobathra bohartiella</i> Opler	<i>Euderus</i> sp., <i>Chrysocharis</i> sp., <i>Sympiesis marylandensis</i> Girault, <i>Cirrospilus flavicinctus</i> Riley, <i>Neochrysocharis</i> sp.‡
<i>Quercus agrifolia</i> Nee	USS	<i>Stigmella variella</i> (Braun)	<i>Chrysocharis</i> sp., <i>Parablastothrix nearctica</i> Miller, <i>Sympiesis</i> sp.‡
<i>Quercus agrifolia</i> Nee	USS/FDBM	<i>Tischeria discreta</i> Braun	<i>Conura</i> sp.‡
<i>Quercus alba</i> L.	LSBM	<i>Phyllonorycter</i> sp.	<i>Pediobius</i> sp.‡
<i>Quercus alba</i> L.	USS/FDBM	<i>Tischeria</i> sp.	<i>Chrysocharis</i> sp.‡

Table 1. Continued.

Plant family/species	Guild	Leafminer	Parasitoids
<i>Quercus alvordiana</i> Eastw.	USS/FDBM	<i>Tischeria</i> sp.	<i>Aprostocetus</i> sp., <i>Comura side</i> (Walker), <i>Miotropis californicus</i> Girault‡
<i>Quercus arizonica</i> Sarg.	USS/FDBM	<i>Tischeria arizonica</i> Braun	<i>Chrysocharis</i> sp., <i>Sympiesis stigmata</i> Girault, <i>Horismenus fraternus</i> (Fitch), <i>Closterocerus cinctipennis</i> Ashmead, <i>Puigalio uroplatae</i> (Provancher), <i>Closterocerus</i> sp.‡
<i>Quercus chrysolepis</i> Liebm.	LSBM	<i>Phyllonorycter</i> sp.	<i>Achrysocharoides villosus</i> Kamijo, <i>Hemiptarsenus</i> sp., <i>Pediobius</i> sp., <i>Chrysocharis</i> sp.†
<i>Quercus chrysolepis</i> Liebm.	USBM	<i>Cameraria diablocensis</i> Opler and Davis	<i>Sympiesis marylandensis</i> Girault, <i>Chrysocharis</i> sp., <i>Ageniaspis bicoloripes</i> (Girault)†
<i>Quercus chrysolepis</i> Liebm.	LSBM	<i>Phyllonorycter leucothorax</i> (Wlsm.)	<i>Chrysocharis</i> sp.‡
<i>Quercus chrysolepis</i> Liebm.	USS	<i>Stigmella</i> sp.	<i>Gelis</i> sp. 4 (fem), <i>Mirax ectoedemiae</i> (Rohwer)‡
<i>Quercus chrysolepis</i> Liebm.	USBM	<i>Cameraria shenanigansensis</i> Opler and Davis	<i>Eupelmus</i> sp., <i>Pteromalinae</i> , <i>Tetrastichinae</i> ‡
<i>Quercus chrysolepis</i> Liebm.	LSBM	<i>Acrocercops</i> n. sp.	<i>Bassus calcaratus</i> (Cresson)†
<i>Quercus chrysolepis</i> Liebm.	LSBM/LR	<i>Caloptilia</i> sp.	<i>Dolichogeniidea</i> sp.†
<i>Quercus chrysolepis</i> Liebm.	USBM	<i>Cameraria</i> sp.	<i>Pholetesor salalicus</i> (Mason)‡
<i>Quercus chrysolepis</i> Liebm.	LSBM	<i>Phyllonorycter</i> sp.	<i>Pholetesor salalicus</i> (Mason)‡
<i>Quercus chrysolepis</i> Liebm.	FDBM	<i>Stilbosis dulcedo</i> (Hodges)	<i>Chelonus</i> sp., <i>Mirax ectoedemiae</i> (Rohwer), <i>Baryscapus</i> sp.†
<i>Quercus douglasii</i> Hook and Arn.	CS/E	<i>Bucculatrix</i> sp.	<i>Stiropius californicus</i> Whitfield‡
<i>Quercus douglasii</i> Hook and Arn.	CS/E	<i>Bucculatrix zophopasta</i> Braun	<i>Pholetesor</i> n. sp. 4‡
<i>Quercus douglasii</i> Hook and Arn.	USBM	<i>Cameraria pentekes</i> Opler and Davis	<i>Pholetesor salalicus</i> (Mason)‡
<i>Quercus dumosa</i> Nutt.	LSBM/LR	<i>Caloptilia</i> sp.	<i>Bassus calcaratus</i> (Cresson)†
<i>Quercus dumosa</i> Nutt.	USBM	<i>Cameraria</i> sp.	<i>Mirax ectoedemiae</i> (Rohwer), <i>Pholetesor salalicus</i> (Mason), <i>Closterocerus ?cincinnatus</i> Girault‡
<i>Quercus dumosa</i> Nutt.	LSBM	<i>Phyllonorycter</i> sp.	<i>Mirax ectoedemiae</i> (Rohwer), <i>Pholetesor salalicus</i> (Mason)‡
<i>Quercus dumosa</i> Nutt.	USS	<i>Stigmella</i> sp.	<i>Paradelius rubra</i> Whitfield‡
<i>Quercus dumosa</i> Nutt.	USBM	<i>Cameraria jacintoensis</i> Opler and Davis	<i>Encyrtinae</i> , <i>Achrysocharoides ?zwoelferi</i> (Delucchi), <i>Aprostocetus</i> sp.‡
<i>Quercus dumosa</i> Nutt.	USS/FDBM	<i>Tischeria consanguinea</i> Braun	<i>Sympiesis marylandensis</i> Girault‡
<i>Quercus dumii</i> Kellogg	USBM	<i>Cameraria</i> nr. <i>temblorensis</i> Opler and Davis	<i>Horismenus</i> sp., <i>Chrysocharis</i> sp., <i>Cirrospilus cinctithorax</i> (Girault), <i>Chrysocharis</i> sp.‡
<i>Quercus durata</i> Jepson	LSBM	<i>Phyllonorycter</i> n. sp.	<i>Pholetesor salalicus</i> (Mason)‡
<i>Quercus durata</i> Jepson	USS	<i>Stigmella</i> sp.	<i>Mirax ectoedemiae</i> (Rohwer)‡
<i>Quercus ?falcata</i> Michx.	USS/FDBM	<i>Tischeria</i> sp.	<i>Pteromalinae</i> ‡
<i>Quercus garryana</i> Hook	USS/FDBM	<i>Tischeria</i> sp.	<i>Puigalio</i> sp.‡

Table 1. Continued.

Plant family/species	Guild	Leafminer	Parasitoids
<i>Quercus garryana</i> Hook	CS/E	<i>Bucculatrix zophopasta</i> Braun	<i>Pholetesor</i> n. sp. †‡
<i>Quercus garryana</i> Hook	LSBM	<i>Phyllonorycter basistrigella</i> (Clemens)	<i>Pholetesor salalicus</i> (Mason) †‡
<i>Quercus glaucooides</i> Martens and Galeotti	USS/FDBM	<i>Tischeria purinosella</i> Cham.	<i>Sympiesis marylandensis</i> Girault, <i>Horismenus</i> sp., <i>Bar-y-scapus</i> sp., <i>Closterocerus trifasciatus</i> Westwood †‡
<i>Quercus glaucooides</i> Martens and Galeotti	USS/FDBM	<i>Tischeria quercitella</i> Clem.	<i>Chrysocharis</i> sp. †‡
<i>Quercus kelloggii</i> Newb.	USBM	<i>Cameraria mediodorsella</i> (Braun)	<i>Pnigalio ?uroplatae</i> (Howard), <i>Pholetesor salalicus</i> (Mason) †‡
<i>Quercus kelloggii</i> Newb.	FDBM	<i>Eriocraniella aurosarsella</i> (Wlsm.)	<i>Sympiesis</i> sp. †‡
<i>Quercus kelloggii</i> Newb.	LSBM	<i>Acrocercops</i> n. sp.	<i>Stiropius wagneri</i> Whitfield †‡
<i>Quercus kelloggii</i> Newb.	CS/E	<i>Bucculatrix</i> sp.	<i>Pholetesor bucculatricis</i> (Muesebeck) †‡
<i>Quercus lobata</i> Nee	CS/E	<i>Bucculatrix</i> sp.	<i>Deuterixys quercicola</i> Whitfield †‡
<i>Quercus lobata</i> Nee	LSBM	<i>Phyllonorycter</i> sp.	<i>Pholetesor salalicus</i> (Mason), <i>Pholetesor salicifoliellae</i> (Mason) †‡
<i>Quercus lobata</i> Nee	USS	<i>Stigmella</i> sp.	<i>Adelius</i> sp. †‡
<i>Quercus lobata</i> Nee	USS/FDBM	<i>Tischeria consanguinea</i> Braun	<i>Pholetesor salalicus</i> (Mason) †‡
<i>Quercus lobata</i> Nee	USBM	<i>Cameraria lobatiella</i> Opler and Davis	<i>Pteromalus</i> ?sp. †‡
<i>Quercus nigra</i> L.	USS/FDBM	<i>Tischeria</i> sp.	<i>Pnigalio flavipes</i> (Ashmead) †‡
<i>Quercus ?nigra</i> L.	USS/FDBM	<i>Tischeria</i> sp.	<i>Pnigalio</i> sp. †‡
<i>Quercus rubra</i>	CS/E	<i>Bucculatrix ainliella</i> Murtfeldt	<i>Pediobius</i> sp. †‡
<i>Quercus stellata</i> Wang.	USS/FDBM	<i>Tischeria ?fuscomarginella</i> Cham.	<i>Chrysocharis</i> sp. †‡
<i>Quercus stellata</i> Wang.	USS/FDBM	<i>Tischeria simulata</i> Braun	<i>Zagrammosoma multilineatum</i> (Ashmead), <i>Horismenus</i> sp., <i>Sympiesis marylandensis</i> Girault †‡
<i>Quercus texana</i> Buckley	USS/FDBM	<i>Tischeria</i> sp.	<i>Sympiesis marylandensis</i> Girault †‡
<i>Quercus turbinella</i> Greene	USBM	<i>Cameraria</i> sp.	<i>Dolichogenidea tischeriae</i> (Viereck), <i>Elachertus cacocia</i> (Howard), <i>Zagrammosoma centrolineatum</i> Crawford, <i>Pholetesor salalicus</i> (Mason) †‡
<i>Quercus vaccinifolia</i> Kellogg	USBM	<i>Cameraria</i> n. sp.	<i>Cirrospilus flavoviridis</i> Crawford, <i>Pnigalio flavipes</i> (Ashmead), <i>Pnigalio boharti</i> Yoshimoto, <i>Pnigalio maculipes</i> (Crawford), <i>Pnigalio brachysellus</i> Yoshimoto, <i>Sympiesis dolichogaster</i> Ashmead, <i>Mesopolobus</i> sp., <i>Agoniaspis bicoloripes</i> (Girault), <i>Sympiesis</i> sp., <i>Chrysocharis</i> sp., <i>Pholetesor salalicus</i> (Mason) †‡

Table 1. Continued.

Plant family/species	Guild	Leafminer	Parasitoids
<i>Quercus wislizenii</i> A. DC.	USBM	<i>Cameraria wislizeniella</i> Opler	<i>Pholetesor salalicus</i> (Mason), <i>Pholetesor</i> n. sp. 3‡
<i>Quercus wislizenii</i> A. DC.	LSBM	<i>Phyllonorycter</i> sp.	<i>Pholetesor salalicus</i> (Mason)‡
<i>Quercus wislizenii</i> A. DC.	USS	<i>Stigmella</i> sp.	<i>Gnamptodon</i> sp.‡
<i>Quercus wislizenii</i> A. DC.	USBM	<i>Cameraria wislizeniella</i> Opler	<i>Pholetesor salalicus</i> (Mason), <i>Sympiesis marylandensis</i> Girault
<i>Quercus wislizenii</i> A. DC.	USBM	<i>Cameraria</i> prob. <i>wislizeniella</i> Opler	<i>Sympiesis marylandensis</i> Girault, <i>Ageniaspis bicoloripes</i> (Girault), <i>Pnigalio levis</i> Yoshimoto, <i>Achrysocharoides ?laticollaris</i> Kamijo‡
<i>Quercus</i> sp.	USS/FDBM	<i>Tischeria citrinipennella</i> Clem.	<i>Chrysocharis</i> sp., <i>Pnigalio</i> sp.‡
<i>Quercus</i> sp.	USS/FDBM	<i>Tischeria zelleriella</i> Cham.	<i>Pnigalio</i> sp., <i>Zagrammosoma multilineatum</i> (Ashmead), <i>Chrysocharis</i> sp., <i>Pediobius</i> sp.‡
<i>Quercus</i> sp.	USBM	<i>Cameraria</i> sp.	<i>Chartocerus</i> sp.‡
<i>Quercus</i> sp.	CS/FDBM	<i>Coptodisca powellella</i> Opler	<i>Chrysocharis</i> n. sp.‡
<b>Grossulariaceae</b>			
<i>Ribes sanguineum</i> Pursh.	LSBM/LS	<i>Caloptilia</i> sp.	<i>Pholetesor salalicus</i> (Mason)‡
<i>Ribes sanguineum</i> Pursh.	LSBM	<i>Phyllonorycter ribefoliae</i> (Braun)	<i>Colastes</i> sp., <i>Pholetesor salicifollicellae</i> (Mason), <i>Sympiesis marylandensis</i> Girault, <i>Closterocerus</i> sp., <i>Achrysocharoides ?zwoelferi</i> (Delucchi)‡
<i>Ribes</i> sp.	LSBM	<i>Phyllonorycter ribefoliae</i> (Braun)	<i>Chrysocharis ainsliei</i> Crawford‡
<b>Hydrophyllaceae</b>			
<i>Eriodictyon trichocalyx</i> Heller	FDBM	<i>Coelopocta glutinosi</i> (Wlsm.) and Agromyzidae (both may be mining)	<i>Zagrammosoma hobbesi</i> LaSalle, <i>Dolichogeniidea tischeriae</i> (Viereck), <i>Microdontomerus anthonomi</i> Crawford, <i>Conura side</i> (Walker), <i>Basus cinctus</i> (Cresson), <i>Chrysocharis ainsliei</i> Crawford, <i>Neochrysocharis</i> sp., <i>Diglyphus begini</i> (Ashmead), <i>Closterocerus cinctipennis</i> Ashmead/ <i>utahensis</i> Crawford (male)‡
<i>Eriodictyon crassifolium</i> Benth.	FDBM	<i>Coelopocta glutinosi</i> (Wlsm.)	<i>Diglyphus begini</i> (Ashmead), <i>Goniozus</i> sp., <i>Chrysocharis ainsliei</i> Crawford‡
<i>Eriodictyon crassifolium</i> Benth.	USS	<i>Phytomyza</i> sp.	<i>Closterocerus utahensis</i> Crawford‡
<i>Phacelia</i> sp.	FDBM	<i>Coelopocta</i> n. sp.	<i>Couura</i> sp., <i>Parahormius</i> sp.‡
<i>Phacelia</i> sp.	FDBM	<i>Coelopocta</i> n. sp.	<i>Zagrammosoma hobbesi</i> LaSalle‡
<b>Lamiaceae</b>			
<i>Lepechinia calycina</i> (Benth.)	CS/E	<i>Bucculatrix</i> sp.	<i>Stiropius californicus</i> Whitefield‡
<i>Lepechinia calycina</i> (Benth.)	LSBM	<i>Cremastobombycia</i> n. sp.	<i>Pholetesor salalicus</i> (Mason)‡

Table 1. Continued.

Plant family/species	Guild	Leafminer	Parasitoids
<i>Salvia mellifera</i> Greene	USS	<i>Liriomyza</i> sp.	<i>Diglyphus begini</i> (Ashmead), <i>Lyrcus justicia</i> (Girault) [?] <sup>†</sup>
<b>Lauraceae</b>			
<i>Umbellularia californica</i> (HandA)	USBM/LS	<i>Caloptilia</i> sp.	<i>Sympiesis dolichogaster</i> (Ashmead) <sup>‡</sup>
<b>Liliaceae</b>			
<i>Smilax</i> sp.	FDBM	<i>Proleucoptera smilaciella</i> (Bsk.)	<i>Aprostocetus</i> sp. <sup>‡</sup>
<i>Yucca baccata</i> Torrey	Stalk borer	<i>Prodoxus coloradensis</i> Riley	<i>Eupelmus</i> sp. <sup>‡</sup>
<b>Malvaceae</b>			
<i>Gossypium</i> sp.	USS		<i>Diglyphus begini</i> (Ashmead) <sup>†</sup>
<i>Malacothamnus</i> sp.	USS/FDBM	<i>Tischeria</i> sp.	<i>Dolichogenidea tischeriae</i> (Viereck), <i>Neochrysocharis diastatae</i> (Howard) <sup>†</sup>
<i>Sidalcea</i> sp.	USS/FDBM	<i>Tischeria omissa</i> Braun	<i>Sympiesis stigmata</i> Girault, <i>Aprostocetus</i> sp. <sup>‡</sup>
<i>Malacothamnus</i> sp.	CB	? <i>Tischeria</i> sp.	<i>Pholetesor salalicus</i> (Mason), <i>Conura side</i> (Walker), <i>Sympiesis stigmata</i> Girault <sup>†</sup>
<b>Myriaceae</b>			
<i>Myrica californica</i> Cham.	USBM	<i>Cameraria umbellulariella</i> (Wlsm)	<i>Pholetesor salalicus</i> (Mason) <sup>‡</sup>
<i>Myrica californica</i> Cham.	USS	<i>Marmara</i> sp.	<i>Mirax ectoedemiae</i> (Rohwer) <sup>‡</sup>
<b>Nyctaginaceae</b>			
<i>Abronia umbellata</i> Lam.	FDBM	<i>Nealyda</i> n. sp.	<i>Zagrammosoma</i> ?n. sp. <sup>†</sup>
<i>Mirabilis</i> sp.	FDBM	Unidentified microlep.	<i>Chelonus</i> sp. <sup>†</sup>
<b>Onagraceae</b>			
<i>Oenothera californica</i> Wats.	CB/E and USS	Chrysomelidae and <i>Liriomyza</i> sp.	<i>Trichomalopsis</i> sp. (on chrysomeid) <sup>†</sup>
<b>Plantanaceae</b>			
<i>Platanus racemosa</i> Nutt.	LSBM	<i>Phyllonorycter felinelle</i> Heinrich	<i>Horismenus texanus</i> (Girault), <i>Chrysocharis walleyi</i> Yoshimoto, <i>Conura side</i> (Walker), <i>Closterocerus</i> sp., <i>Diglyphus begini</i> (Ashmead), <i>Sympiesis marylandensis</i> Girault <sup>†</sup>
<b>Poaceae</b>			
<i>Elymus glaucus</i> Buckley	CS/FDBM	<i>Elachista</i> sp.	<i>Pholetesor</i> n. sp. 5, <i>Bracon</i> sp. <sup>‡</sup>
<i>Ehrharta erecta</i> Lam.	CS/FDBM	<i>Elachista</i> sp.	<i>Colastes</i> sp., <i>Pholetesor bedelliae</i> (Viereck) <sup>‡</sup>
<i>Hierochloe</i> sp.	CS/FDBM	<i>Elachista</i> sp.	<i>Colastes</i> sp., <i>Pholetesor bedelliae</i> (Viereck) <sup>‡</sup>
bunchgrass	CS/FDBM	<i>Elachista</i> sp.	<i>Pholetesor bedelliae</i> (Viereck) <sup>‡</sup>
<b>Rhamnaceae</b>			
<i>Ceanothus cuneatus</i> (Hook.)	USS	<i>Stigmella</i> sp.	<i>Mirax ectoedemiae</i> (Rohwer) <sup>‡</sup>
<i>Ceanothus crassifolius</i> Torr.	USS/FDBM	<i>Tischeria</i> sp.	<i>Chrysocharis</i> n. sp., <i>C. niphercus</i> (Walker), <i>Dolichogenidea tischeriae</i> (Viereck) <sup>†</sup>
<i>Ceanothus greggii</i> Gray	USS	? <i>Marmara</i> sp.	<i>Neochrysocharis diastatae</i> (Howard) <sup>†</sup>
<i>Ceanothus greggii</i> Gray	USS/FDBM	? <i>Tischeria</i> sp.	<i>Mesopolobus</i> sp., <i>Zagrammosoma mirum</i> Girault, <i>Z. americanum</i> Girault <sup>†</sup>
<i>Ceanothus integerrimus</i> H and A	CS/E	<i>Bucculatrix ceanothi</i> Braun	<i>Pholetesor bucculatricis</i> (Muesebeck) <sup>‡</sup>

Table 1. Continued.

Plant family/species	Guild	Leafminer	Parasitoids
<i>Ceanothus integerrimus</i> H and A	USS	<i>Stigmella</i> sp.	<i>Adelius</i> sp., <i>Gnamptodon</i> sp.‡
<i>Ceanothus integerrimus</i> H and A	USS/FDBM	<i>Tischeria</i> sp.	<i>Apanteles</i> sp.‡
<i>Ceanothus integerrimus</i> H and A	CB		<i>Zagrammosoma americanum</i> Girault†
<i>Ceanothus integerrimus</i> H and A	USS	<i>Stigmella ceanothii</i> (Braun)	<i>Chrysocharis</i> sp.‡
<i>Ceanothus leucodermis</i> Greene	USS/FDBM	<i>Tischeria</i> sp. and <i>Recurvaria</i> sp.	<i>Cirrospilus coachellae</i> Gates, <i>Bassus cinctus</i> (Cresson), <i>Elachertus cacociae</i> (Howard), <i>Chelonus</i> sp.†
<i>Ceanothus thyrsiflorus</i> Eschsch.	CS/E	<i>Bucculatrix ?ceanothii</i> Braun	<i>Pholetesor bucculatricis</i> (Muesebeck)‡
<i>Ceanothus thyrsiflorus</i> Eschsch.	USS/FDBM	<i>Tischeria</i> sp.	<i>Apanteles</i> sp.‡
<i>Ceanothus velutinus</i> Dougl. <i>Ceanothus</i> sp.	USS/FDBM	<i>Tischeria</i> sp. <i>Acanthopteroctetes unifascia</i> (Davis)	<i>Apanteles</i> sp.‡ <i>Mirax ectoedemiae</i> (Rohwer)†
<i>Ceanothus</i> sp.	USS/FDBM	<i>Tischeria ceanothii</i> Walsingham	<i>Colastes</i> sp., <i>Apanteles</i> sp.†
<i>Ceanothus</i> sp.	USS/FDBM	"leafminer"	<i>Apanteles</i> sp.‡
<i>Ceanothus</i> sp.	USS/FDBM	<i>Lyonetia ?prunifoliella</i> (Hübner)	<i>Pnigalio flavipes</i> (Ashmead), <i>Cirrospilus cinctithorax</i> (Girault)‡
<i>Ceanothus</i> sp.	USS		<i>Sympiesis stigmata</i> Girault†
<i>Ceanothus</i> sp.	USS	<i>Stigmella</i> sp.	<i>Parablastothrix nearctica</i> Miller, <i>Cirrospilus flavoviridis</i> Crawford†
<i>Ceanothus</i> sp.	USS	<i>Stigmella ceanothii</i> (Braun)	<i>Chrysocharis</i> sp.‡
<i>Ceanothus</i> sp.	USS	<i>Stigmella inconspicuellae</i> Newton and Wilkinson	<i>Chrysocharis</i> sp., <i>Ageniaspis bicoloripes</i> (Girault)‡
<i>Ceanothus</i> sp.	USS/FDBM	<i>Tischeria ceanothii</i> Braun	<i>Cirrospilus</i> sp.†
<i>Rhamnus alnifolia</i> L'Her.	USS	<i>Stigmella</i> sp.	<i>Mirax ectoedemiae</i> (Rohwer)‡
<i>Rhamnus californica</i> Eschsch.	USS	? <i>Stigmella</i> sp.	<i>Mauleus nigrinus</i> (Howard), <i>Chrysocharis walleyi</i> Yoshimoto, <i>Diglyphus</i> sp., <i>Neochrysocharis</i> sp., <i>Neochrysocharis diastatae</i> (Howard), <i>Closterocerus cincinnatus</i> Girault, <i>Ageniaspis bicoloripes</i> (Girault)†
<i>Rhamnus californica</i> Eschsch.	USS/B	<i>Phyllonorycter incanella</i> (Wlsm.)	<i>Neochrysocharis diastatae</i> Howard†
<i>Rhamnus californica</i> Eschsch.	USS	<i>Stigmella</i> sp.	<i>Cirrospilus</i> sp., <i>Chrysocharis</i> sp., <i>Chrysocharis clarkae</i> Yoshimoto, <i>Adelius</i> sp., <i>Colastes</i> sp., <i>Gnamptodon</i> sp.‡
<i>Rhamnus crocea</i> Nutt.	CS/FDBM	<i>Apophthisis congregata</i> Braun	<i>Mirax</i> sp., <i>Mirax ectoedemiae</i> (Rohwer), <i>Gelis</i> sp. 2 (male), <i>Miotropis californicus</i> Girault†
<i>Rhamnus crocea</i> Nutt.	USS	<i>Stigmella</i> sp.	<i>Mirax ectoedemiae</i> (Rohwer), <i>Paradelius rubra</i> Whitfield‡

Table 1. Continued.

Plant family/species	Guild	Leafminer	Parasitoids
<i>Rhamnus rubra</i> Greene	C/FDBM	<i>Apoplthisis congregata</i> Braum	<i>Pnigalio flavipes</i> (Ashmead), <i>Sympiesis stigmata</i> Girault, <i>Adelius</i> sp., <i>Colastes</i> sp.† <i>Mirax ectoedemiae</i> (Rohwer)‡
<i>Rhamnus purshiana</i> DC.	SSM	<i>Marmara</i> sp.	
<b>Rosaceae</b>			
<i>Amelanchier alnifolia</i> (Nutt.)	LSBM/LS	<i>Parornix ?alta</i> (Braun)	<i>Pholetesor salicifoliellae</i> (Mason), <i>Rhysipolis decorator</i> (Haliday), <i>Sympiesis</i> sp., <i>Elachertus cacaoecia</i> (Howard)‡
<i>Amelanchier alnifolia</i> (Nutt.)	LSBM	<i>Phyllonorycter</i> sp.	<i>Sympiesis marylandensis</i> Girault‡
<i>Cercocarpus betuloides</i> Nutt.	CS/FDBM	<i>Coptodisca</i> sp.	<i>Mirax ectoedemiae</i> (Rohwer)‡
<i>Cercocarpus betuloides</i> Nutt.	SSM	<i>Marmara</i> sp.	<i>Mirax ectoedemiae</i> (Rohwer)‡
<i>Cercocarpus betuloides</i> Nutt.	USS	<i>Stigmella</i> sp.	<i>Apanteles</i> sp., <i>Chelonius</i> sp., <i>Gelis</i> sp. 1 (fem)‡
<i>Cercocarpus betuloides</i> Nutt.	CS/FDBM	<i>Coptodisca cercocarpella</i> Braun	<i>Apanteles</i> prob. n. sp., <i>Neochrysocharis diastatae</i> (Howard), <i>Chrysocharis</i> sp.†
<i>Cercocarpus ledifolius</i> Nutt.	USS	<i>Stigmella</i> sp.	<i>Cirrospilus flavoviridis</i> Crawford, <i>Chelonius</i> sp., <i>Chrysocharis wahl</i> Hansson, <i>Apanteles</i> nr. <i>scutellaris</i> (Meus.)†
<i>Cotoneaster</i> sp.	LSBM	<i>Phyllonorycter mespilella</i> (Hübner)	<i>Chrysocharis walleyi</i> Yoshimoto‡
<i>Crataegus douglasii</i> Lindley	LSBM/LS	<i>Parornix</i> sp.	<i>Sympiesis</i> sp.‡
<i>Crataegus</i> sp.	LSBM	<i>Phyllonorycter mespilella</i> (Hübner)	<i>Pholetesor salicifoliellae</i> (Mason)
<i>Fragaria vesca</i> L.	USS/FDBM	<i>Tischeria</i> sp.	<i>Mirax ectoedemiae</i> (Rohwer)
<i>Heteromeles arbutifolia</i> (Lindley)	SSM	<i>Marmara</i> sp.	<i>Chelonius</i> sp., <i>Mirax ectoedemiae</i> (Rohwer)‡
<i>Holodiscus discolor</i> (Pursh.)	LSBM	<i>Phyllonorycter holodisci</i> (Braun)	<i>Sympiesis dolichogaster</i> (Ashmead)‡
<i>Horkelia</i> sp.	FDBM	<i>Scrobipalpula</i> sp.	<i>Dolichogenidea</i> sp.‡
<i>Lyonothamnus floribundus</i> A. Gray	USS	<i>Stigmella</i> n. sp.	<i>Mirax ectoedemiae</i> (Rohwer)‡
<i>Prunus andersonii</i> A. Gray	LSBM	<i>Parornix</i> sp.	<i>Apanteles</i> sp.‡
<i>Prunus emarginata</i> (Hook.)	LSBM/LS	<i>Caloptilia</i> sp.	<i>Pholetesor salicifoliellae</i> (Mason)‡
<i>Prunus ilicifolia</i> (Nutt.)	FDBM	<i>Paraleucoptera heinrichi</i> Jones	<i>Chelonius</i> sp., <i>Mirax ectoedemiae</i> (Rohwer), <i>Cirrospilus cinctithorax</i> (Girault), <i>Pnigalio flavipes</i> (Ashmead), <i>Scambus hirticauda</i> (Provancher), <i>Viridipyge prunicola</i> Whitfield‡
<i>Prunus ilicifolia</i> (Nutt.)	USS	<i>Stigmella</i> sp.	<i>Parablastothrix nearctica</i> Miller, <i>Chrysocharis</i> sp., <i>Cirrospilus flavoviridis</i> Crawford‡
<i>Prunus ilicifolia</i> (Nutt.)	USS or LSS	<i>Phyllocnistis</i> sp.	<i>Chrysocharis walleyi</i> Yoshimoto, <i>Pnigalio coloni</i> Girault, <i>Sympiesis</i> sp.‡
<i>Prunus ilicifolia lyonii</i> (Eastw.) Raven	USS	<i>Stigmella</i> sp.	<i>Mirax ectoedemiae</i> (Rohwer)‡

Table 1. Continued.

Plant family/species	Guild	Leafminer	Parasitoids
<i>Prunus virginiana</i> L.	LSBM/LS	<i>Parornix</i> sp.	<i>Sympiesis marylandensis</i> Girault, <i>Pholetesor salalicus</i> (Mason)‡
<i>Prunus virginiana</i> L.	LSBM/LS	? <i>Parornix</i> sp.	<i>Colastes</i> sp., <i>Pholetesor salicifoliellae</i> (Mason)‡
<i>Prunus</i> sp.	LSBM/LR	<i>Caloptilia invariabilis</i> Braun	<i>Sympiesis marylandensis</i> Girault, <i>Aprostocetus</i> sp.‡
<i>Rosa</i> sp.	USBM	<i>Ectoedemia</i> sp.	<i>Mirax ectoedemiae</i> (Rohwer)‡
<i>Rubus parviflorus</i> Nutt.	USS/FDBM	<i>Tischeria splendida</i> Braun	<i>Colastes</i> sp., <i>Mirax ectoedemiae</i> (Rohwer)‡
<i>Rubus ursinus</i> Cham. and Schldl.	SSM	<i>Marmara</i> sp.	<i>Mirax ectoedemiae</i> (Rohwer)‡
<i>Rubus</i> sp.	USBM	<i>Ectoedemia rubifoliella</i> (Clem.)	<i>Chrysocharis</i> sp.‡
Unidentified Rosaceae	LSBM	<i>Phyllonorycter mespilella</i> (Hübner)	<i>Sympiesis</i> sp.‡
<b>Rubiaceae</b>			
<i>Cephalanthus occidentalis</i> Benth.	CS/FDBM	<i>Mompha cephalanthiella</i> (Cham.)	<i>Pnigalio flavipes</i> (Ashmead)‡
<b>Rutaceae</b>			
<i>Citrus</i> × <i>paradisi</i> MacFad.	Peelmine	<i>Marmara gulosa</i> Guillén and Davis	<i>Pnigalio coloni</i> (Girault), <i>Closterocerus utahensis</i> Ashmead, <i>Cirrospilus coachellae</i> Gates‡
<i>Citrus</i> × <i>paradisi</i> MacFad.	LSS and USS/SSM	<i>Phyllocnistis citrella</i> Stainton	<i>Closterocerus utahensis</i> Crawford‡
<b>Salicaceae</b>			
<i>Populus fremontii</i> Wats.	LSBM/LR	<i>Caloptilia palustriella</i> (Braun)	<i>Pholetesor salicifoliellae</i> (Mason)‡
<i>Populus fremontii</i> Wats.	FDBM	<i>Paraleucoptera albella</i> (Cham.)	<i>Pholetesor</i> n. sp. 4‡
<i>Populus</i> sp.	LSBM	<i>Phyllonorycter nipigon</i> (Freeman)	<i>Sympiesis</i> ? <i>marylandensis</i> Girault, <i>Zagrammosoma multilineatum</i> (Ashmead), <i>Sympiesis stigmata</i> Girault, <i>Zagrammosoma americanum</i> Girault, <i>Sympiesis sericeicornis</i> (Nees).
<i>Populus</i> sp.	LSBM	<i>Phyllonorycter</i> sp.	<i>Apanteles</i> sp.‡
<i>Salix coulteri</i> Anderss.	LSBM	<i>Phyllonorycter apicinigiella</i> (Clem.)	<i>Colastes</i> sp.‡
<i>Salix laevigata</i> Bebb	LSBM/LS	<i>Caloptilia palustriella</i> Braun	<i>Pnigalio levis</i> Yoshimoto‡
<i>Salix lasiolepis</i> Benth.	FDBM	<i>Paraleucoptera albella</i> (Cham.)	<i>Zagrammosoma americanum</i> Girault‡
<i>Salix lasiolepis</i> Benth.	USBM	blotch miner	<i>Bassus</i> sp.‡
<i>Salix lasiolepis</i> Benth.	USS	<i>Stigmella</i> sp.	<i>Mirax ectoedemiae</i> (Rohwer)‡
<i>Salix</i> sp.	USS/FDBM	<i>Coptodisca saliciella</i> (Clem.)	<i>Colastes</i> sp.‡
<i>Salix</i> sp.	LSBM/FDBM	<i>Microrapteryx salicifoliella</i> (Cham.)	<i>Pholetesor salalicus</i> (Mason)‡
<i>Salix</i> sp.	LSBM	<i>Phyllonorycter</i> sp.	<i>Pholetesor salicifoliellae</i> (Mason)‡
<i>Salix</i> sp.	LSBM	<i>Phyllonorycter deserticola</i> Davis and Desc.	<i>Sympiesis marylandensis</i> Girault, <i>Pnigalio flavipes</i> (Ashmead), <i>Pnigalio</i> sp.‡
<i>Salix</i> sp.	LSBM	<i>Phyllonorycter crugatus</i> Davis and Desc.	<i>Sympiesis marylandensis</i> Girault, <i>Sympiesis sericeicornis</i> (Nees)‡

Table 1. Continued.

Plant family/species	Guild	Leafminer	Parasitoids
<i>Salix</i> sp.	LSBM	<i>Phyllonorycter salicifoliella</i> (Clem.)	<i>Sympiesis sericeicornis</i> (Nees), <i>Sympiesis marylandensis</i> Girault, <i>Chrysocharis</i> spp., <i>Chrysocharis bori-quensis</i> Hansson, <i>Achrysocharoides ?zwoelferi</i> (Delucchi), <i>Cirrospilus cinctithorax</i> (Girault), <i>Diglyplus pulchripes</i> (Crawford), <i>Aprostocetus</i> sp.‡
<i>Salix</i> sp.	LSBM	<i>Phyllonorycter scudderella</i> (F and B)	<i>Sympiesis</i> sp.‡
<i>Salix</i> sp.	LSBM/LS	<i>Caloptilia palustriella</i> Braun	<i>Sympiesis marylandensis</i> Girault, <i>Sympiesis bimaculati-pennis</i> Girault, <i>Cirrospilus flavicinctus</i> Riley, <i>Sympiesis sericeicornis</i> (Nees), <i>Pholetesor salalicus</i> (Mason)‡
<i>Salix</i> sp.	LSBM/LS	<i>Caloptilia</i> sp. (coastal)	<i>Sympiesis marylandensis</i> Girault‡
<i>Salix</i> and <i>Populus</i>	FDBM	<i>Coptodisca saliciella</i> (Clem.)	<i>Cirrospilus</i> sp.‡
<b>Sapindaceae</b>			
<i>Acer macrophyllum</i> Pursh	LSBM/LS	<i>Caloptilia</i> sp.	<i>Sympiesis marylandensis</i> Girault, <i>Ageniaspis bicoloripes</i> (Girault), <i>Chelonus</i> sp., <i>Pholetesor salicifoliellae</i> (Mason), <i>Rhysipolis decorata</i> (Hal.), <i>Diaglyptidea</i> sp., <i>Scambus hirticauda</i> (Provancher)‡
<i>Acer negundo</i> L.	LSBM/LS	<i>Caloptilia negundella</i> (Cham.)	<i>Pholetesor bedelliae</i> (Viereck)‡
<b>Scrophulariaceae</b>			
<i>Keckiella cordifolia</i> (Benth.)	CB		<i>Phygadeuon</i> sp.‡
<i>Penstemon caesius</i> A. Gray	CS		<i>Chrysocharis ainsliei</i> Crawford, <i>Eurytoma</i> sp., <i>Callimerismus</i> ?n. sp., <i>Thimodytes petiolatus</i> Heydon‡
<b>Solanaceae</b>			
<i>Lycium cooperi</i> Gray	LTM	?Gelechiinae	<i>Apanteles</i> nr. <i>scutellaris</i> (Mues.), <i>Habrobracon</i> sp.‡
<i>Lycopersicon esculentum</i> Mill.	USS	Agromyzidae	? <i>Closterocerus</i> sp.‡
<i>Nicotiana glauca</i> Grah.	SSM	<i>Marmara</i> n. sp.	<i>Cirrospilus coachellae</i> Gates‡
<b>Thymelaeaceae</b>			
<i>Dirca occidentalis</i> A. Gray	USBM	<i>Leucanthiza dircella</i> Braun	<i>Colastes</i> sp.‡
<b>Tropaleaceae</b>			
<i>Tropaleum nasturtium</i> L.	CS	<i>Liriomyza</i> ?sp.	<i>Diglyplus begini</i> (Ashmead)‡
<b>Ulmaceae</b>			
<i>Ulmus</i> sp.	USBM	<i>Cameraria ulmella</i> (Cham.)	<i>Ageniaspis bicoloripes</i> (Girault), <i>Sympiesis</i> sp.‡
<b>Verbenaceae</b>			
<i>Lantana camara</i> L.	USBM	<i>Liriomyza</i> sp.	<i>Diglyplus begini</i> (Ashmead), <i>Halticoptera</i> sp., <i>Baryscapus</i> sp., <i>Closterocerus</i> sp.‡

Table 1. Continued.

Plant family	species	Guild	Leafminer	Parasitoids
<b>Vitaceae</b>				
<i>Vitis californica</i>	Benth.	USS	? <i>Phyllocnistis</i> sp.	<i>Chrysocharis walleyi</i> Yoshimoto, <i>Phigalio levis</i> Yoshimoto, <i>Zagrammosoma</i> sp., <i>Hormius</i> sp., <i>Neochrysocharis arizonensis</i> (Crawford), <i>Cirrospilus cinctithorax</i> (Girault), <i>Cirrospilus</i> sp.†
<b>Miscellany—plant unknown</b>				
??		USS/FDBM	<i>Tischeria</i> sp.	<i>Zagrammosoma mirum</i> Girault‡

Leafmine Guild abbreviations are as follows: CB = complete blotch, CS = complete serpentine, CB/E = complete blotch with internal/external feeding, CS/E = complete serpentine then external, LR = leaf roll, LS = leaf shelter, LSBM = lower surface blotch, LSS = lower surface serpentine, LTM = leaf(-ves) tied/mined, MVT = mines vascular tissue, SSM = stem serpentine, USS = upper surface serpentine, USS/FDBM = upper surface, full depth blotch mine, USBM = upper surface blotch, >> = guild on left side of >> becomes the guild on the right side of the >>.

† Indicates parasitoids reared from individual leafmines.

‡ Indicates parasitoids lot-reared from >1 leafmines from a single plant.

suspended ceilings. This enabled rapid viewing of multiple vials simultaneously rather than examining each vial separately. Once processed, samples were placed into rectangular Rubbermaid<sup>®</sup> tubs containing saturated salt solution which maintained relative humidity at ~75% (Winston and Bates 1960). Samples were examined daily, and any emergence recorded. Rearing success was approximately 18%. Parasitoids and leafmining Agromyzidae were killed with 70% ethanol and prepared for mounting using hexamethyldisilazane (HMDS) dehydration (Heraty and Hawks 1998). Leafmining Lepidoptera were prepared according to Landry and Landry (1994).

Protocols of DLW and JBW presented in Whitfield and Wagner (1988) are reiterated here. The DLW and JBW plant material collected in the field was sorted by plant and miner species, and subsequently isolated by plant/miner lot in clear polyethylene bags lined with paper toweling (which often provided a pupation substrate for both the miners and their parasitoids). Most smaller lots were reared in 15–40 dram plastic vials (Wagner, pers. comm.). For overwintering generations,

leaves or leaf portions with mines were placed in plastic snap-top vials and held for at least 6 weeks in a refrigerator or freezer to break diapause, before removal from cold for adult emergence. No success rates on a per leaf mine basis are possible given that much of the samples were bulk reared. Plant identifications were mostly supplied by the collectors; some difficult determinations were made by the herbarium staff of the University of California, Berkeley. Adult leafminers and mines were identified by DLW, with some additional identifications supplied by JBW and by J. A. Powell and J. A. DeBeneditis of the University of California at Berkeley.

Illustrations in this paper provide representation of the features diagnostic of a particular taxon even though they may not be derived from actual specimens recovered in this study. Many of the line illustrations are taken with permission from the following sources: Goulet and Huber 1995, Townes 1970a, b, Gibson et al. 1997, Schauff et al. 1998. Diagnoses are modified from Schauff et al. (1998) and the references provided therein are for known works on a particular taxon worldwide.

Taxa known to attack CLM have been recorded previously (Schauff et al. 1998). Other genera attacking leafminers not treated herein, particularly within Chalcidoidea, most likely remain to be discovered with continued rearing of Californian leafminers. Readers are referred to keys in Gibson et al. (1997) for keys to Nearctic Chalcidoidea, to Whitfield and Wagner (1991) for Braconidae, and Townes (1970a, b) for Ichneumonidae.

New host/parasitoid associations for Chalcidoidea only, based upon comparison with records found in Noyes (1998), are indicated by an asterisk in Table 2. Distributional notes appearing after the diagnosis of each genus are taken primarily from Krombein et al. (1979), Noyes (1998) and Gibson et al. (1997). Only Chalcidoidea are treated in Table 2 as there exists no definitive work analogous to the Noyes CD-ROM that treats any of the non-Chalcidoidea taxa documented herein. However, as Noyes (1998) is only a compilation of the literature pertaining to Chalcidoidea, information therein is only as reliable as its original source. Although many parasitoids included here were reared from a single leafmine (indicated with + (Table 1)), other parasitoids issued from bulk rearing of numerous leafmines from a single plant host in a single bag (indicated with ++ (Table 1)). The labeling scheme (+,++) used in Table 1 pro-

vides an indication as to the relative degree of definitiveness of a particular host/parasitoid interaction. Those records with a single + should be regarded as probable associations since all mines were reared individually. A [?] preceding a taxon name in Table 1 indicates that the taxon is tentatively identified, typically due to specimen collapse or other damage obscuring diagnostic characters. Those taxa are identified to genus in all but 6 instances where only subfamily identification is possible. All specimens from MWG/JMH rearings are deposited at UCRC and those of DLW and JBW are in the collections of University of Connecticut and University of Illinois, respectively. The Ichneumonidae identified by David Wahl are deposited in AEIC.

Morphological terms are indicated on several figures (Figs. 1–10, 12–17, 19–21, 28, 31–32, 35, 55, 60–61, 63, 66–68, 72–73, 78, 79, 81, 84–85, 87, 89, 102–103, 106, 108–109, 114–115, 117) and not discussed in detail. Gastral tergum is abbreviated as Gtn where n = gastral tergite number. Further discussion of morphology of Hymenoptera in general and Chalcidoidea in particular can be found in Goulet and Huber (1995) and Gibson et al. (1997), respectively.

Acronyms are: UCRC = University of California Collection, Riverside, CA; AEIC = American Entomological Institute Collection, Gainesville, Florida.

KEY TO FAMILIES AND GENERA OF CALIFORNIA LEAFMINER PARASITOIDS

- 1 Apterous. Antenna with more than 13 flagellomeres (Fig. 13). Ovipositor prominently exerted, 1.0–1.3× as long as length of hind femur. Trochantellus present (trochanter appearing two-segmented (Fig. 13)) . . . . . 1 . . . . . *Gelis* (ICHNEUMONIDAE: CRYPTINAE)
- 1' Macropterous. Antenna with ≤13 flagellomeres (or, if >13 flagellomeres, then macropterous (Braconidae)). Ovipositor sometimes exerted and as long as or longer than length of hind femur. Trochantellus present or absent (trochanter appearing one- or two-segmented) . . . . . 2
- 2 Fore wing venation complete, with at least 2 closed cells (Figs. 5, 7, 19–20). CHRYSIDOIDEA, ICHNEUMONOIDEA . . . . . 3
- 2' Fore wing venation reduced, with fewer than 2 closed cells (Fig. 45). CHALCIDOIDEA . . . . . 12
- 3 Abdominal sterna as strongly sclerotized as terga; head prognathous; pronotum shaped

like truncated pyramid in dorsal view (Fig. 23); clypeus with median longitudinal carina (Fig. 23). CHRYSIDOIDEA: BETHYLIDAE ..... 9. *Goniozus*

3' Abdominal sterna less strongly sclerotized than terga; head usually hypognathous (Figs. 10–15); pronotum transverse to subquadrate in dorsal view; clypeus lacking median longitudinal carina. ICHNEUMONOIDEA ..... 4

4 Fore wing with vein 1/Rs+M separating cells 1M and 1R1 (Fig. 7); hind wing with vein 1r-m basal to separation of veins R1 and Rs (Figs. 3, 9); metasomal terga 2+3 fused with inflexible junction (Fig. 11). BRACONIDAE ..... See pg. 248

4' Fore wing without vein 1/Rs+M, with compound cell 1M+1R1 present (Fig. 5); hind wing with vein 1r-m opposite or apical to separation of veins R1 and Rs (Figs. 1–2); metasomal tergum 2 usually separate from tergum 3, with flexible junction (Fig. 10). ICHNEUMONIDAE ..... 5

5 Fore wing cell 1+2Rs (=areolet) large and rhombic (diamond-shaped) (Figs. 5, 14). Ovipositor long and needle-like, ovipositor sheath long and rigid. Male genitalia with gonoforceps produced into elongate process (Fig. 16). Upper margin of supraclypeal area with transverse carina below antennal sockets ..... 2. *Mesochorus* (MESOCHORINAE)

5' Fore wing cell 1+2Rs obliquely quadrate, pentagonal, or open (vein 3r-m absent) (Figs. 12, 15). Ovipositor stouter, ovipositor sheath sometimes curved. Male genitalia with gonoforceps not produced into elongate process. Upper margin of supraclypeal area without transverse carina below antennal sockets ..... 6

6 Metasomal segment 1 in dorsal view with apex about as wide as base. Tergite 1 with glymma present at base of tergite (Fig. 10) ..... 7

6' Metasomal segment 1 petiolate in dorsal view, apex 1.8–3.3× as wide as base. Tergite 1 with glymma absent ..... 8

7 Pleural sulcus (=mesopleural suture) without distinct angulation opposite scrobe (Fig. 15). Hind wing with vein 2-cu meeting vein cu-a distinctly closer to vein M than vein 1A (Fig. 15). Hind tibia fuscous with median pale band, apex thus being dark ..... 3. *Pimpla* (PIMPLINAE)

7' Pleural sulcus with distinct angulation opposite scrobe (Fig. 8). Hind wing with vein 2-cu meeting vein cu-a more or less equidistant between veins M and 1A (Fig. 18). Hind tibia with apical and subapical dark bands, extreme base thus being pale ..... 4. *Scaubus* (PIMPLINAE)

8 Propleuron with ventroposterior corner having strongly produced, more or less angulate lobe touching or overlapping pronotum (cf. Fig. 26). Mesothorax ventrally with postpectal carina complete (Fig. 4). Mesopleuron with sternaulus short, about 0.3× as long as mesopleuron (Fig. 17) ..... 5. *Caupoplex* (CAMPOPLEGINAE)

8' Propleuron with ventroposterior corner not produced as distinct lobe, not angulate, at most with weak groove delimiting it from main area of propleuron (cf. Fig. 27). Mesothorax ventrally with postpectal carina interrupted in front of each middle coxa or completely absent. Mesopleuron with sternaulus extending to middle coxa or nearly so ..... 9

9 Outer face of mandible with sub-basal swelling, at extreme base with transverse groove that emphasizes swelling. Lateral face of pronotum with epomia absent and surface granulate ..... 1. *Gelis* (CRYPTINAE)

9' Outer face of mandible without sub-basal swelling. Lateral face of pronotum with epomia present (Fig. 6) and surface polished and rugulose ..... 10

10 Notaulus long and sharp, ending beyond middle of mesoscutum (Fig. 50). Apex of clypeus with two median denticles ..... 8. *Bathylthrix* (CRYPTINAE)

10' Notaulus not reaching middle of mesoscutum. Apex of clypeus without denticles ..... 11

11 Apical 0.3 of clypeus strongly inflexed and covered with brush of long setae ..... 6. *Diaglyptidea* (CRYPTINAE)

11' Clypeus uniformly convex and without brush of long setae .. 7. *Eucrateola* (CRYPTINAE)

12 Tarsi 5 segmented, protibial spur curved apically and bifid (Fig. 24). Funicle with 5 or more segments (Figs. 32, 35) ..... 13

12' Tarsi 4 segmented, protibial spur straight and simple (Fig. 25). Funicle with 2–4 segments (Figs. 28, 30, 31, 33, 38–39) EULOPHIDAE ..... 31

13 Mesopleuron swollen, convex, glabrous, longer than high (Figs. 61, 63) ..... 14

13' Mesopleuron not swollen, concave, variously sculptured, shorter than high (Figs. 51–52) ..... 16

14 Mesocoxa inserted at or anterior to midline of mesopleuron (Fig. 61). Cercus usually advanced (Fig. 61). Marginal vein usually shorter than stigmal vein (Figs. 29, 42) ENCYRTIDAE ..... 15

14' Mesocoxa inserted posterior to midline of mesopleuron (Fig. 63). Cercus never advanced, placed at apex of metasoma (Fig. 66). Marginal vein usually longer than stigmal vein (as in Figs. 41, 44). EUPELMIDAE (females) ..... 20

15 Scutellum with deep longitudinal striate sculpture contrasting with shallow reticulate sculpture on mesoscutum. Clava 1-segmented (Fig. 35). PMV at least 1.5× as long as stigmal vein (Fig. 42). Eye not approaching mouth margin, malar space >¼ eye length. Male with all funiculars unbranched ..... 10. *Ageniaspis*

15' Scutellum lacking striate sculpture, with reticulate sculpture similar to mesoscutum. Clava 3-segmented. PMV <1.5× as long as stigmal vein (Fig. 29). Eye nearly reaching mouth margin, malar space <¼ eye length (Fig. 60). Male with first four funiculars branched (as in Fig. 33) ..... 11. *Parablastothrix*

16 Hind femur enlarged, <3× as long as broad, dentate ventrally (Fig. 103). Axillar and parascutal carinae converging directly above wing base in arch-like fashion (Fig. 102). CHALCIDIDAE ..... 17

16' Hind femur not enlarged, >3× as long as broad, smooth ventrally (as in Figs. 36–37). Axillar and parascutal carinae converging on dorsum mesad of wing base in V-like fashion (as in Fig. 81) ..... 18

17 Gaster petiolate, petiole subquadrate to very long (Fig. 107); propodeum with spiracle subvertical or nearly longitudinal ..... 12. *Conura*

17' Gaster sessile, petiole at most visible as transverse line (Fig. 102); propodeum with spiracle mostly diagonal (Fig. 104) ..... 13. *Brachymeria*

18 Pronotum quadrate in dorsal view (Fig. 106). Head and dorsum with umbilicate sculpture (Fig. 106). Body usually non-metallic (black, yellow, brown). EURYTOMIDAE ..... 34. *Enrytoma*

18' Pronotum transverse in dorsal view (as in Figs. 62, 64, 84). Head and dorsum lacking umbilicate sculpture, usually reticulate (as in Figs. 64, 79, 101). Body usually metallic (green, blue) ..... 19

19 Pronotum in dorsal view narrowed medially (Fig. 64). Notauli absent (Fig. 64). Protibia with dorsoapical spicules (Fig. 65) EUPELMIDAE (males) ..... 20

19' Pronotum in dorsal view not narrowed medially (Fig. 118). Notauli at least visible anteriorly on mesoscutum, often complete (Fig. 79). Protibia lacking dorsoapical spicules ... 21

20 Metasoma with posterior margin of syntergum deeply, subcircularly emarginate, the emargination often surrounding a sclerotized horizontal to vertical anal sclerite (Fig. 68); mesotibia lacking apical groove between tibial spur and base of tarsus (Fig. 69); metasoma with penultimate tergum medially divided or with median hyaline line and largely or entirely concealed under preceding tergum ..... 32. *Enpelmus*

20' Metasoma with posterior margin of syntergum truncate or variously differentiated into a rim or fingernail-like flange (Fig. 66); mesotibia almost always with apical groove between tibial spur and base of tarsus (Fig. 67); metasoma with penultimate tergum neither divided nor largely or entirely concealed under preceding tergum ..... 33. *Brasema*

21 Head with occipital carina (may be fine) (Figs. 48–49). Metacoxa usually subtriangular in cross section and broadly attached to mesosoma (Figs. 51–52). Fore wing usually with marginal vein long and stigmal vein short (Figs. 40–41). TORYMIDAE ..... 22

21' Head without occipital carina, or if with carina then metacoxa usually subcircular in cross

- section and narrowly attached to mesosoma. Fore wing venation different than above (Figs. 44, 46, 55). PTEROMALIDAE ..... 23
- 22 Metapleuron separated by a straight line from mesopleuron, not projecting anteriorly (Fig. 51). Metafemur convex ventrally, sometimes serrate (Fig. 46). Marginal vein at most 5 times as long as stigmal vein and more than 3 times as long as postmarginal vein (as in Fig. 41) ..... 43. *Microdontomerus*
- 22' Metapleuron separated by a sinuous line from mesopleuron, projecting anteriorly (Fig. 52). Metafemur not convex ventrally, sometimes serrate (as in Fig. 36). Marginal vein at most 5 times as long as stigmal vein and more than 3 times as long as postmarginal vein (as in Fig. 40) ..... 44. *Torymus*
- 23 Clypeal margin at least slightly asymmetric, with 2 or 3 teeth separated by at least one deep incision (Figs. 73, 82). MISCOGASTERINAE ..... 24
- 23' Clypeal margin usually symmetric and without deep incision, at most with shallow emargination (Figs. 78, 83, 112). PTEROMALINAE, SPALANGIINAE ..... 27
- 24 Propodeum strongly sculptured, reticulate to rugose, submedially (as in Fig. 80). Clypeal margin with 3 asymmetric teeth ..... 35. *Callimerismus*
- 24' Propodeum glabrous to moderately reticulate (Figs. 72, 76) or with two convergent submedian lines of punctures (Fig. 113). Clypeal margin usually with 2–3 more or less asymmetric teeth or entire and produced (Figs. 78, 82, 112) ..... 25
- 25 Clypeal margin either with one asymmetrical tooth (Fig. 75) or with 3 teeth, but then teeth usually sharp and with only a narrow gap between them ..... 36. *Thiudytes*
- 25' Clypeal margin usually with two distinct teeth having broad gap between them (Figs. 73, 82) ..... 26
- 26 Torulus at or below lower eye margin. Petiole usually with median carina and with anterolateral corners not enlarged (Fig. 74). *Males*: palpus and/or stipes more or less enlarged, yellow (Fig. 73) ..... 37. *Halticoptera*
- 26' Torulus above lower eye margin. Petiole usually without median carina and with anterolateral corners sharp and enlarged (as in Fig. 77). *Males*: palpus and/or stipes slender, dark ..... 38. *Manlens*
- 27 Toruli at extreme lower margin of head (Fig. 112). Head almost prognathous. Flagellum lacking anellus and with 7 funiculars. SPALANGIINAE ..... 42. *Spalangia*
- 27' Toruli never so low on face, typically closer to middle (Figs. 78, 81). Head hypognathous. Flagellum with 1–3 anelli (Fig. 32). PTEROMALINAE ..... 28
- 28 Antenna with 2 anelli and 6 funicular segments (Fig. 32). Occiput with fine to strong arched margin or fold (as in Fig. 49) ..... 39. *Trichomalopsis*
- 28' Antenna with 3 anelli and five funicular segments. Occiput lacking margin or fold .... 29
- 29 Pronotal collar with an abruptly angled or rounded margin (Fig. 81). Head moderate in dorsal view,  $>2.0\times$  as long as broad. Gena curved to more angulate (Fig. 78). Hypopygium  $>0.5\times$  the length of gaster ..... 40. *Mesopolobus*
- 29' Pronotal collar less abruptly angled, often only margined medially (Fig. 70). Head stout in dorsal view,  $<2.0\times$  as long as broad. Gena moderately curved and converging in anterior view (Fig. 56). Hypopygium  $<0.5\times$  the length of gaster ..... 41. *Pteromalus*
- 30 Scutellum with 2 pairs of setae (Fig. 91), rarely more. Submarginal vein with 1 or more setae dorsally (as in Figs. 45, 57). Head with transverse fronto-facial suture, if present, adjacent to anterior ocellus (Fig. 110). Notauli present or absent (Figs. 99, 114). EULOPHIDAE: Eulophinae, Tetrastichinae, Euderinae ..... 31
- 30' Scutellum with 1 pair of setae (Figs. 84–87). Submarginal vein with 2 setae dorsally (Figs. 53–54, 59). Head with transverse fronto-facial suture, if present, separated from anterior ocellus by distance greater than diameter of ocellus (Fig. 89). Notauli usually absent (Fig. 87). EULOPHIDAE: Entedoninae ..... 34
- 31 Notauli present and either reaching posterior margin of mesoscutum or curving to meet axillae (Figs. 108, 114) ..... 32

- 31' Notauli absent or incomplete posteriorly and not approaching posterior margin of mesoscutum or axillae (Figs. 87–88, 95, 111) . . . . . 33
- 32 Fore wing posteriad of marginal vein usually with bare area except for distinct row of admarginal setae on ventral surface (Fig. 45), and usually with 2–3 rows of setae radiating from stigmal vein (Fig. 45). EUDERINAE . . . . . 31. *Euderus*
- 32' Fore wing different, if with bare area posteriad of marginal vein, then lacking such distinctive rows of radiating setae (Fig. 54) . . . . . 33
- 33 Postmarginal vein reduced or absent, less than  $\frac{1}{2}$  length of stigmal vein (Fig. 57). Scutellum with paired submedial grooves, often with sublateral grooves, grooves never convergent apically (Figs. 91, 93). Notaulus always complete, axilla strongly advanced, scapula linear. Funicular segments: female with 3 and male with 4. TETRASTICHINAE . . . . . 40
- 33' Postmarginal vein present, at least  $\frac{1}{2}$  length of stigmal vein (Figs. 54, 59). Scutellum lacking paired submedial grooves and sublateral grooves, at most with single pair of submedian grooves which are or are not convergent apically (Figs. 95, 97–100). Notaulus complete or incomplete, when complete then axilla either not or only slightly advanced, scapula triangular. Funicular segments never in above combination. EULOPHINAE . . . . . 41
- 34 Propodeum with shiny medial strip, bordered laterally by depressed and usually sculptured area, area laterad of depressed area usually also shiny (Fig. 85). Scutellum with median longitudinal groove running almost entire length (Fig. 84). ENTEDONINAE . . . . . 25. *Horismenus*
- 34' Propodeum not as above, with or without median carina, but never with shiny median strip. Scutellum generally without median longitudinal groove . . . . . 35
- 35 Propodeum with distinct plica, and with paired median carina which diverge posteriorly (Fig. 86). Pronotum with a transverse carina on anterior edge . . . . . 26. *Pediobius*
- 35' Propodeum without plica, without median carina which diverge posteriorly. Pronotum with or without a transverse carina on anterior edge . . . . . 37
- 37 Postmarginal vein elongate, at least  $1.5\times$  as long as stigmal vein (Fig. 53) . . . . . 27. *Chrysocharis*
- 37' Postmarginal vein shorter, at most as long as stigmal vein (Figs. 54, 59) . . . . . 38
- 38 Frontofacial groove transverse, straight, slightly raised (Fig. 89). Eye pilose. Postmarginal vein about equal in length to stigmal vein (as in Fig. 59). Mesoscutum and/or scutellum often with pits (Fig. 88) . . . . . 28. *Achrysocharoides*
- 38' Frontofacial grooves present as V- or Y-shaped sutures (Fig. 110). Other characters variable, never present in above combination . . . . . 39
- 39 Fore wing lacking line of setae extending distally from stigmal vein (Fig. 59), never with infusate transverse bands (Fig. 59). Transepimeral suture distinctly curved (Fig. 115) . . . . . 29. *Neochrysocharis*
- 39' Fore wing with single line of setae extending distally from stigmal vein (Fig. 54), sometimes with infusate transverse bands (Fig. 54). Transepimeral suture straight or only slightly curved (Fig. 117) . . . . . 30. *Closterocerus*
- 40 Propodeal callus with raised lobe overhanging outer rim of spiracle (Fig. 91). Cercal setae unequal in length, one distinctly longer than others and sinuate (Fig. 92) . . . . . 24. *Aprostocetus*
- 40' Propodeal callus without raised lobe overhanging rim of spiracle (Fig. 93). Cercal setae equal in length, the two longest being subequal and straight or only slightly curved (Fig. 94) . . . . . 23. *Baryscapus*
- 41 Funicle 2 segmented (Fig. 28) . . . . . 42
- 41' Funicle 3 or 4 segmented (Figs. 30–31, 38–39) . . . . . 45
- 42 Scutellum with submedian grooves (Fig. 95). Notauli incomplete (Fig. 95) . . . . . 14. *Diglyphus*
- 42' Scutellum without submedian grooves. Notauli complete (Fig. 114) . . . . . 43
- 43 Notauli curving to meet anterior portion of axilla (Fig. 108). Axilla more or less advanced anteriorly beyond transscutal articulation (Fig. 108). Color yellow and black, never metallic and fore wing often with infusate areas . . . . . 16. *Zagrammosoma*
- 43' Notauli straight, extending to anterior portion of scutellum (Fig. 114). Axilla not greatly

- advanced beyond transscutal articulation (Fig. 114). Body color variable, wing rarely infusate ..... 44
- 44 Postmarginal vein about  $2\times$  as long as stigmal vein. *Male*: scape enlarged (Fig. 28). Scutellum without submedian grooves. Color brown ..... 17. *Diaulinopsis*
- 44' Postmarginal vein equal to or shorter than stigmal vein (Fig. 58). *Male*: scape rarely enlarged. Scutellum with submedian grooves, though may be difficult to see due to changes in color pattern. Color variable, but often with extensive yellow markings ... 15. *Cirrospilus*
- 45 Notauli incomplete; male funicle often with long branches (Fig. 33) ..... 46
- 45' Notauli complete, sometimes fine; male funicle often without or rarely with long branches ..... 47
- 46 Propodeum with complete plica and a transverse costula extending from each plica to median carina (Fig. 98), the area between glabrous ..... 18. *Puigalio*
- 46' Propodeum without costula and usually without plica (Fig. 99), but if plicae present then area between distinctly reticulate ..... 48
- 47 Torulus high on head, above lower eye margin, thus apex of scape extends beyond level of vertex (Fig. 90). Fore wing and costal cell narrow, fore wing at least  $2.6\times$  as long as broad and costal cell  $10-15\times$  as long as broad ..... 20. *Hemiptarsenus*
- 47' Torulus at or below lower eye margin, thus apex of scape not extending beyond level of vertex. Fore wing and costal cell not so narrow, fore wing less than  $2.6\times$  as long as broad and costal cell less than  $10\times$  as long as broad ..... 19. *Sympiesis*
- 48 Scutellum with submedian grooves complete, curving medially at posterior margin and meeting or nearly meeting each other (Fig. 100) ..... 21. *Elachertus*
- 48' Scutellum with submedian grooves incomplete or absent, but if present then grooves usually straight, not curving or curving slightly mesad at posterior margin of scutellum (Fig. 96) ..... 22. *Miotropis*

## Superfamily Ichneumonoidea

### Family ICHNEUMONIDAE

#### Subfamily Cryptinae

#### 1. Genus *Gelis* Thunberg

(Fig. 13)

*Diagnosis*.—Females are apterous, with either apterous, brachypterous, or macropterous males; sometimes both sexes are macropterous. Mandible with strong sub-basal swelling, at extreme base with transverse groove that emphasizes swelling. Clypeus weakly convex and without brush of long setae; apex often with weak median denticles. Center of pronotum without median longitudinal carina; lateral face without epomia. Mesoscutum with notaulus not reaching middle; surface matte. Cell 1+2Rs of fore wing often open.

*Notes*.—This genus is represented by at least 80 species in the Nearctic region and 10 species in California (Carlson 1979). Members of this genus are attack small co-

coons of Lepidoptera, Neuroptera and other Ichneumonoidea, usually as a hyperparasitoid but occasionally as a primary parasitoid of small Lepidoptera. Other species parasitize eggs sacs of Araneae.

#### Subfamily Mesochorinae

#### 2. Genus *Mesochorus* Gravenhorst

(Figs. 14, 16)

*Diagnosis*.—Upper margin of supra-clypeal area with transverse carina below antennal sockets. Cell 1+2Rs of fore wing large and rhombic (diamond-shaped). Vein 2-Cu of hind wing. Glymmae of tergite 1 large and deep, almost meeting at midpoint. Ovipositor long and needle-like; ovipositor sheath long and rigid. Male genitalia with gonoforceps produced into elongate process.

*Notes*.—This large genus is worldwide in distribution, with 106 described species in the Nearctic; 22 of these occur in Cali-

Table 2. List of reared chalcidoid species and their leafmining hosts.

Parasitoid species	Host species*
<i>Achrysocharoides ?laticollaris</i> Kamijo	Unknown
<i>Achrysocharoides villosus</i> Kamijo	<i>Phyllonorycter</i> sp. ( <i>Quercus chrysolepis</i> Leibm.) <sup>*1</sup>
<i>Achrysocharoides ?zwoelferi</i>	<i>Cameraria jacintoensis</i> Opler and Davis*
	<i>Cameraria nemoris</i> (Wlsm.)*
	<i>Lirionymza sativae</i> Blanchard*
	<i>Phyllonorycter arbutusella</i> Braun*
	<i>Phyllonorycter ledella</i> Wlsm.*
	<i>Phyllonorycter ribefoliae</i> (Braun)*
	<i>Phyllonorycter salicifoliella</i> (Clem.)*
	<i>Phyllonorycter</i> sp. <sup>1</sup> ( <i>Q. chrysolepis</i> )
<i>Aprostocetus</i> sp.	<i>Caloptilia invariabilis</i> Braun*
	<i>Cameraria agrifoliella</i> (Braun)*
	<i>Cameraria jacintoensis</i> Opler and Davis*
	<i>Cremastobombycia grindeliella</i> Wlsm.*
	<i>Phyllonorycter salicifoliella</i> (Clem.)*
	<i>Proleucoptera smilaciiella</i> (Bsk.)*
	<i>Tischeria omissa</i> Braun*
	<i>Tischeria</i> sp. ( <i>Aster</i> sp., <i>Quercus alvordiana</i> Eastw.)
<i>Baryscapus</i> sp.	<i>Stilbosis dulcedo</i> Hodges*
	<i>Tischeria pruinosella</i> Cham.*
	<i>Lirionymza</i> sp. ( <i>Lantana camara</i> L.)
<i>Brachymeria</i> sp.	Unknown lepidopteran
<i>Brasema ?macrocarpae</i> (Ashmead)	<i>Lirionymza</i> sp.* ( <i>Datisca glomerata</i> (Presl.))
<i>Chrysocharis ainsliei</i> Crawford	<i>Coelopoeta glutinosi</i> (Wlsm.)*
	<i>Phyllonorycter ribefoliae</i> (Braun)*
	<i>Calcomyza enceliae</i> Spencer*
	<i>Calcomyza</i> sp.* ( <i>Xanthium strumarium</i> L.)
	<i>Chromatomyia syngenesiae</i> Hardy
	<i>Phyllonorycter salicifoliella</i> (Clem.)*
<i>Chrysocharis boriquensis</i> Hansson	<i>Stigmella</i> sp.* ( <i>Rhamnus californica</i> Eschsch.)
<i>Chrysocharis ?clarkae</i> Yoshimoto	<i>Lirionymza</i> sp. ( <i>Datisca glomerata</i> (Presl.))
<i>Chrysocharis oscirioidis</i> Ashmead	<i>Tischeria</i> sp. ( <i>Ceanothus crassifolius</i> Torr.)
<i>Chrysocharis nephereus</i> (Walker)	<i>Stigmella</i> sp. ( <i>Cercocarpus ledifolius</i> Nutt.)
<i>Chrysocharis wahlii</i> Hansson	<i>Phyllocnistis</i> sp.* ( <i>Prunus ilicifolia</i> (Nutt.))
<i>Chrysocharis wallei</i> Yoshimoto	? <i>Phyllocnistis</i> sp.* ( <i>Vitis californica</i> Benth.)
	<i>Phyllonorycter fellinelle</i> Heinrich*
	<i>Phyllonorycter mespilella</i> (Hübner)
	? <i>Stigmella</i> sp.* ( <i>Rhamnus californica</i> Eschsch.)
<i>Chrysocharis</i> n. sp.	<i>Coptodisca powellella</i> Opler
	<i>Tischeria</i> sp. ( <i>Ceanothus crassifolius</i> Torr.)
<i>Cirrospilus cinctithorax</i> Girault	<i>Cameraria nr temblorensis</i> Opler and Davis*
	<i>Lyonetia ?prunifoliella</i> (Hübner)*
	<i>Paraleucoptera heinrichi</i> Jones*
	? <i>Phyllocnistis</i> sp. ( <i>Vitis californica</i> Benth.)
	<i>Phyllonorycter salicifoliella</i> (Clem.)
<i>Cirrospilus coachellae</i> Gates	<i>Marmara gulosa</i> Guillén and Davis
	<i>Marmara</i> n. sp. ( <i>Nicotiana glauca</i> Grah.)
	<i>Tischeria</i> sp.* ( <i>Ceanothus leucodermis</i> Greene)
<i>Cirrospilus flavoviridis</i> Crawford	<i>Cameraria sempervirensella</i> Opler and Davis*
	<i>Stigmella</i> sp.* ( <i>Ceanothus</i> sp., <i>Cercocarpus ledifolius</i> Nutt., <i>Prunus ilicifolia</i> (Nutt.))
	<i>Cameraria</i> n. sp.* ( <i>Quercus vaccinifolia</i> Kellogg)
<i>Cirrospilus flavicinctus</i> Riley	<i>Caloptilia palustriella</i> Braun*
	<i>Neurobatlira bohartiella</i> Opler*

Table 2. Continued.

Parasitoid species	Host species*
<i>Closterocerus utahensis</i> Crawford	<i>Coelopoeta glutinosi</i> (Wlsm.)* <i>Liriomyza sativae</i> Blanchard <i>Liriomyza</i> sp. ( <i>Bidens pilosa</i> L.) <i>Marmara gulosa</i> Guillén and Davis* <i>Phyllocnistis citrella</i> Stainton* ? <i>Phytomyza</i> sp. ( <i>Eriodictyon crassifolius</i> Benth.) <i>Stigmella rhoifoliella</i> (Braun)*
<i>Closterocerus cinctipennis</i> Ashmead	<i>Coelopoeta glutinosi</i> (Wlsm.)* <i>Marmara gulosa</i> Guillén and Davis* <i>Tischeria arizonica</i> Braun*
<i>Closterocerus ?submutica</i> Graham	<i>Liriomyza</i> sp. ( <i>Cirsium vulgare</i> (Savi))
<i>Closterocerus trifasciatus</i> Westwood	<i>Lyonetia latistrigella</i> Wlsm.* <i>Tischeria purinosella</i> Cham.*
<i>Comura side</i> (Walker)	<i>Coelopoeta glutinosi</i> (Wlsm.)* <i>Phyllonorycter felinelle</i> Heinrich* <i>Tischeria</i> sp. ( <i>Quercus alvordiana</i> Eastw.)
<i>Comura</i> sp.	<i>Coelopoeta</i> n. sp.* ( <i>Phacelia</i> sp.) <i>Tischeria discreta</i> Braun* ? <i>Tischeria</i> sp. ( <i>Malacothamnus</i> sp.)
<i>Diaulinopsis callichroma</i> Crawford	<i>Liriomyza sativae</i> Blanchard*
<i>Diglyphus begini</i> (Ashmead)	<i>Liriomyza</i> spp. ( <i>Salvia mellifera</i> Greene, <i>Tropaeum nasturtium</i> L., <i>Lantana camara</i> L., <i>Bidens pilosa</i> L., <i>Silybum marianum</i> Gaertn., <i>Hirschfeldia incana</i> (L.)) <i>Chromatomyia syngenesiae</i> Hardy <i>Coelopoeta glutinosi</i> (Wlsm.)* <i>Phyllonorycter felinelle</i> Heinrich* <i>Phyllonorycter salicifoliella</i> (Clem.)
<i>Diglyphus pulchripes</i> (Crawford)	<i>Phyllonorycter salicifoliella</i> (Clem.)
<i>Elachertus cacoccia</i> (Howard)	<i>Cameraria</i> sp.* ( <i>Quercus turbinella</i> Greene) <i>Parornix ?alta</i> (Braun)* <i>Tischeria</i> sp.* ( <i>Ceanothus leucodermis</i> Greene)
<i>Euderus</i> sp.	<i>Neurobathra bohartiella</i> Opler*
<i>Eupelmus</i> sp.	<i>Cameraria shenanniganensis</i> Opler and Davis* <i>Prodoxus coloradensis</i> Riley*
<i>Halticoptera</i> sp.	<i>Calomyza</i> sp.* ( <i>Xanthium strumarium</i> L.) <i>Liriomyza</i> sp. ( <i>Lantana camara</i> L.)
<i>Horismenus fraternus</i> (Fitch)	<i>Phyllonorycter</i> sp. ( <i>Quercus agrifolia</i> Nees) <i>Tischeria arizonica</i> Braun*
<i>Horismenus texanus</i> Girault	<i>Phyllonorycter felinelle</i> Heinrich*
<i>Lycus justicia</i> Girault	<i>Liriomyza</i> sp. ( <i>Salvia mellifera</i> Greene)
<i>Maulius nigrinus</i> (Howard)	? <i>Stigmella</i> sp.* ( <i>Rhamnus californica</i> Eschsch.)
<i>Mesopolobus</i> sp.	<i>Cameraria sempervirensella</i> Opler and Davis* <i>Coleophora</i> sp. ( <i>Aster chilensis</i> Nees) <i>Tischeria</i> sp. ( <i>Ceanothus greggii</i> Gray)
<i>Microdromeris anthonomi</i> Crawford	<i>Coelopoeta glutinosi</i> (Wlsm.)*
<i>Miotropis californicus</i> Girault	<i>Apothesis congregata</i> Braun* <i>Tischeria</i> sp.* ( <i>Quercus alvordiana</i> Eastw.)
<i>Neochrysocharis arizonensis</i> (Crawford)	<i>Liriomyza sativae</i> Blanchard*
<i>Neochrysocharis diastatae</i> (Howard)	Agromyzidae <i>Coptodisca cercocarpella</i> Braun*
<i>Neochrysocharis diastatae</i> (Howard)	? <i>Marmara</i> sp.* ( <i>Ceanothus greggii</i> Gray) <i>Neurobathra bohartiella</i> Opler* <i>Phyllonorycter incanella</i> (Wlsm.)* ? <i>Stigmella</i> sp.* ( <i>Rhamnus californica</i> Eschsch.) <i>Tischeria</i> sp.* ( <i>Malacothamnus</i> sp.)

Table 2. Continued.

Parasitoid species	Host species*
<i>Parablastothrix nearctica</i> Miller	<i>Stigmella variella</i> (Braun)*
<i>Ageniaspis bicoloripes</i> (Girault)	<i>Stigmella</i> sp. ( <i>Ceanothus</i> sp., <i>Prunus ilicifolia</i> (Nutt.))
	<i>Caloptilia</i> sp.* ( <i>Acer macrophyllum</i> Pursh.)
	<i>Cameraria diabloensis</i> Opler and Davis*
	<i>Cameraria gaultheriella</i> Wlsm.*
	<i>Cameraria ulmella</i> (Cham.)*
	<i>Cameraria</i> prob. <i>wislizeniella</i> Opler*
	<i>Cameraria</i> n. sp.* ( <i>Quercus vaccinifolia</i> Kellogg)
	<i>Phyllonorycter</i> sp. ( <i>Quercus agrifolia</i> Nee)
	<i>Stigmella inconspicua</i> Newton and Wilkinson*
	? <i>Stigmella</i> sp. ( <i>Rhamnus californica</i> Eschsch.)*
<i>Pediobius acantha</i> (Walker)	<i>Chromatomyia syngenesiae</i> Hardy
<i>Pediobius albipes</i> (Provancher)	<i>Antispila aurirubra</i> Braun*
<i>Pnigalio boharti</i> Yoshimoto	<i>Cameraria sempervirensella</i> Opler and Davis*
<i>Pnigalio brachysellus</i> Yoshimoto	<i>Cameraria sempervirensella</i> Opler and Davis*
<i>Pnigalio coloni</i> (Girault)	<i>Chromatomyia syngenesiae</i> Hardy*
	<i>Liriomyza</i> sp.* ( <i>Datisca glomerata</i> (Presl.))
	<i>Marmara gulosa</i> Guillén and Davis*
	<i>Phyllocnistis</i> sp.* ( <i>Prunus ilicifolia</i> (Nutt.))
<i>Pnigalio flavipes</i> (Ashmead)	<i>Antispila aurirubra</i> Braun*
	<i>Apophthisis congregata</i> Braun*
	<i>Lyonetia</i> ? <i>prunifoliella</i> (Hübner)*
	<i>Cameraria agrifoliella</i> (Braun)*
	<i>Cameraria sempervirensella</i> Opler and Davis*
	<i>Lyonetia candida</i> Braun*
	<i>Mompha cephalanthiella</i> (Cham.)*
	<i>Paraleucoptera heinrichi</i> Jones*
	<i>Phyllonorycter deserticola</i> Davis and Desc.*
	<i>Phyllonorycter manzanitae</i> Braun*
	<i>Tischeria</i> sp. ( <i>Aster</i> sp., <i>Quercus nigra</i> L.)
<i>Pnigalio levis</i> Yoshimoto	<i>Caloptilia palustriella</i> Braun*
	<i>Cameraria</i> sp.* ( <i>Quercus wislizenii</i> A. DC.)
	? <i>Phyllocnistis</i> sp.* ( <i>Vitis californica</i> Benth.)
	<i>Phyllonorycter</i> sp.* ( <i>Quercus agrifolia</i> Nee)
<i>Pnigalio maculipes</i> (Crawford)	<i>Cameraria sempervirensella</i> Opler and Davis*
<i>Pnigalio uroplatae</i> (Howard)	<i>Cameraria mediadorsella</i> (Braun)*
	<i>Tischeria arizonica</i> Braun*
<i>Pteromalus</i> sp.	<i>Cameraria lobatiella</i> Opler and Davis*
<i>Spalangia</i> sp.	<i>Liriomyza</i> sp.* ( <i>Datisca glomerata</i> (Presl.))
<i>Sympiesis bimaculatipennis</i> (Girault)	<i>Caloptilia palustriella</i> Braun*
<i>Sympiesis seiceicornis</i> (Nees)	<i>Caloptilia palustriella</i> Braun*
	<i>Phyllonorycter erugatus</i> Davis and Desc.*
	<i>Phyllonorycter nipigon</i> (Freeman)*
	<i>Phyllonorycter salicifoliella</i> (Clem.)
<i>Sympiesis seiceicornis</i> (Nees)	? <i>Periploca</i> sp. ( <i>Simmondsia chinensis</i> Link.)
<i>Sympiesis dolichogaster</i> Ashmead	<i>Cameraria sempervirensella</i> Opler and Davis
	<i>Phyllonorycter holodisci</i> (Braun)*
<i>Sympiesis marylandensis</i> Girault	<i>Cameraria agrifoliella</i> (Braun)*
	<i>Cameraria shenanniganensis</i> Opler and Davis*
	<i>Cameraria wislizeniella</i> Opler*
	<i>Caloptilia diversilobiella</i> Opler*
	<i>Caloptilia invariabilis</i> Braun*
	<i>Caloptilia</i> sp. (coastal population)* ( <i>Salix</i> sp.)
	<i>Caloptilia</i> sp.* ( <i>Acer macrophyllum</i> Pursh.)

Table 2. Continued.

Parasitoid species	Host species*
	<i>Neurobatlra bohartiella</i> Opler*
	<i>Tischeria simulata</i> Braun*
	<i>Parornix</i> sp. ( <i>Prunus virginiana</i> L., <i>Prunus</i> sp.)
	<i>Phyllonorycter deserticola</i> Davis and Desc.*
	<i>Phyllonorycter erugatus</i> Davis and Desc.*
	<i>Phyllonorycter felinelle</i> Heinrich*
	<i>Phyllonorycter nipigon</i> (Freeman)*
	<i>Phyllonorycter ribefoliae</i> (Braun)*
	<i>Phyllonorycter salicifoliella</i> (Clem.)
	<i>Phyllonorycter</i> sp. ( <i>Amelanchier</i> sp.)
	<i>Tischeria consanguinea</i> Braun*
	<i>Tischeria purinosella</i> Cham.*
	<i>Tischaeria</i> sp. ( <i>Quercus texana</i> Buckley)
<i>Sympiesis stigmata</i> Girault	<i>Apophthisis congregata</i> Braun*
	? <i>Periploca</i> sp. ( <i>Simmondsia chinensis</i> (Link.))
	<i>Phyllonorycter arbutusella</i> Braun*
	<i>Phyllonorycter manzanitae</i> Braun*
	<i>Phyllonorycter nipigon</i> (Freeman)*
	<i>Tischeria arizonica</i> Braun*
	<i>Tischeria omissa</i> Braun*
	? <i>Tischeria</i> sp. ( <i>Aster</i> sp.)
<i>Thinodytes caroticus</i> Heydon	<i>Calomyza</i> sp. ( <i>Xanthium strumarium</i> L.)
<i>Trichomalopsis</i> sp.	Chrysomelidae*
	? <i>Periploca</i> sp. ( <i>Simmondsia chinensis</i> (Link.))*
<i>Zagrammosoma americanum</i> Girault	<i>Paraleucoptera albella</i> (Cham.)*
	<i>Phyllonorycter nipigon</i> (Freeman)*
<i>Zagrammosoma centrolineatum</i> Crawford	<i>Cameraria</i> sp. ( <i>Quercus turbinella</i> Greene)
<i>Zagrammosoma hobbsi</i> LaSalle	<i>Coelopoeta glutinosi</i> (Wlsm.)*
	<i>Coelopoeta</i> n. sp.* ( <i>Phacelia</i> sp.)
<i>Zagrammosoma mirum</i> Girault	<i>Tischeria</i> sp.* ( <i>Ceanothus greggii</i> Gray)
<i>Zagrammosoma multilincatum</i> (Ashmead)	<i>Phyllonorycter nipigon</i> (Freeman)*
	<i>Tischeria simulata</i> Braun*
	<i>Tischeria zelleriella</i> Cham.*

\* Indicates previously unrecorded host for that taxon.

<sup>†</sup> Taxa in the host species column only identified to genus are followed parenthetically by the host plant from which they were reared.

**Notes:** Ichneumonidae rearings excluded. No comprehensive work on their biology exists with which to compare our records. All rearing records are included in this table.

fornia (Yu 1998). All mesochorines are obligate hyperparasitoids of endoparasitic Ichneumonidae (and, rarely, Tachinidae) which parasitize primary hosts of larval Lepidoptera, Symphyta, and Coleoptera, and nymphal and adult Hemiptera and Psocoptera (Wahl 1993). Although some authors (Carlson 1979) place credence in reports of mesochorines acting as primary parasitoids, Wahl (1993) expressed doubt about these records.

### Subfamily Pimplinae

#### 3. Genus *Pimpla* Fabricius (Fig. 15)

*Diagnosis.*—Eye not emarginate opposite antennal socket. Supra-antennal area black. Pleural sulcus (= mesopleural suture) without distinct angulation opposite scrobe. Fore tarsal claw of female simple. Hind tibia fuscous with median pale band, apex thus being dark. Vein 2-cu of hind wing meeting vein cu-a distinctly

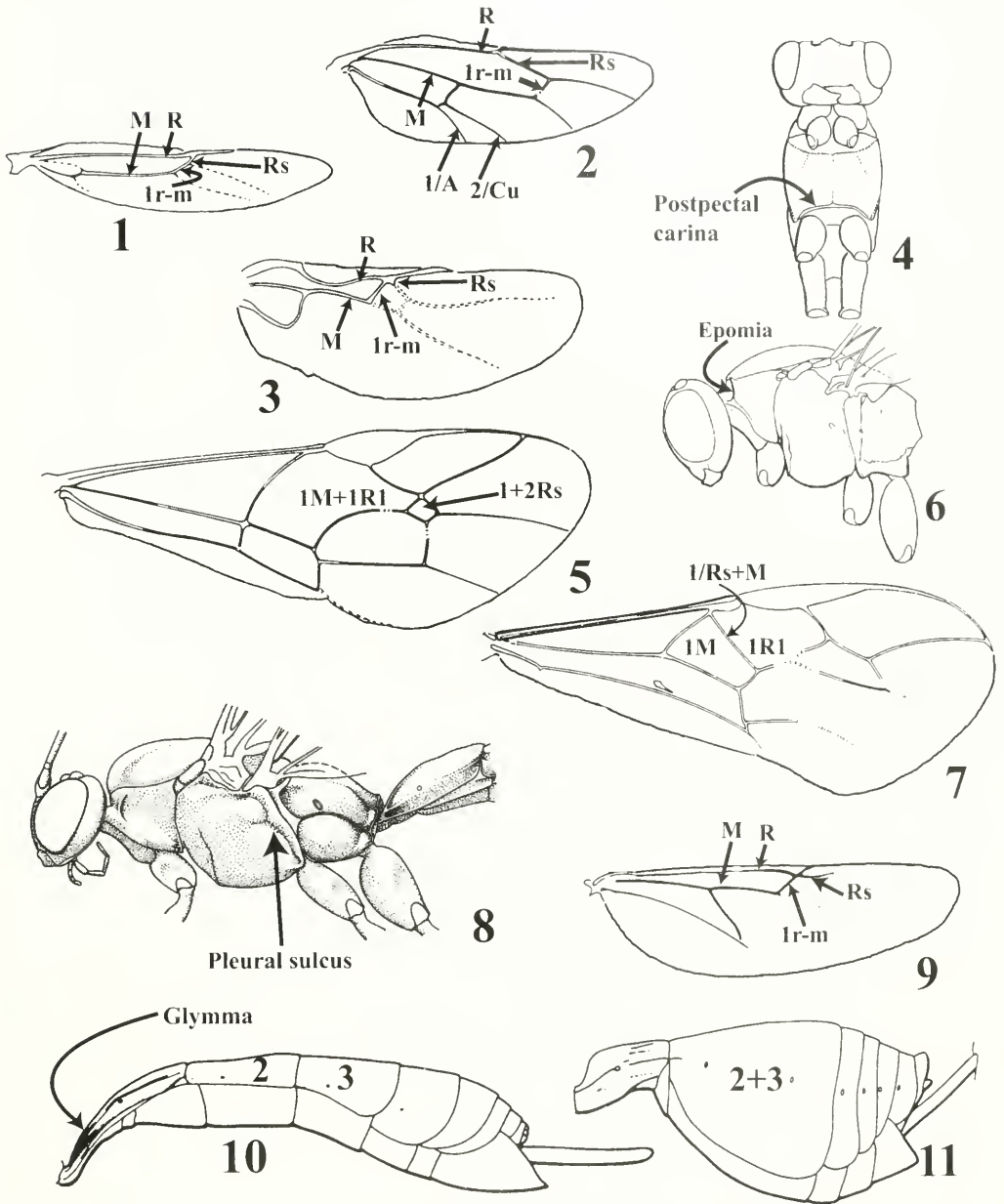

Figs. 1-11. 1, 6, 9, Ichneumonoidea: 1, 9, hind wings. 6, lateral mesosoma. 2, 4, 10, Ichneumonidae: 2, hind wing. 4, ventral mesosoma. 10, lateral gaster. 5, Ichneumonidae: Mesochorinae, fore wing. 3, 7-8, 11, Braconidae: 3, microgastrine hind wing. 7, fore wing. 11, lateral mesosoma. 8, *Dolichotomius* sp., lateral habitus.

closer to vein M than vein 1A. Ovipositor tip straight, not abruptly downcurved.

*Notes.*—Twenty species of this genus have been described from the Nearctic,

with seven of them occurring in California (Townes and Townes 1960, Carlson 1979). They are idiobiont endoparasitoids of Lepidoptera pupae. Townes referred to

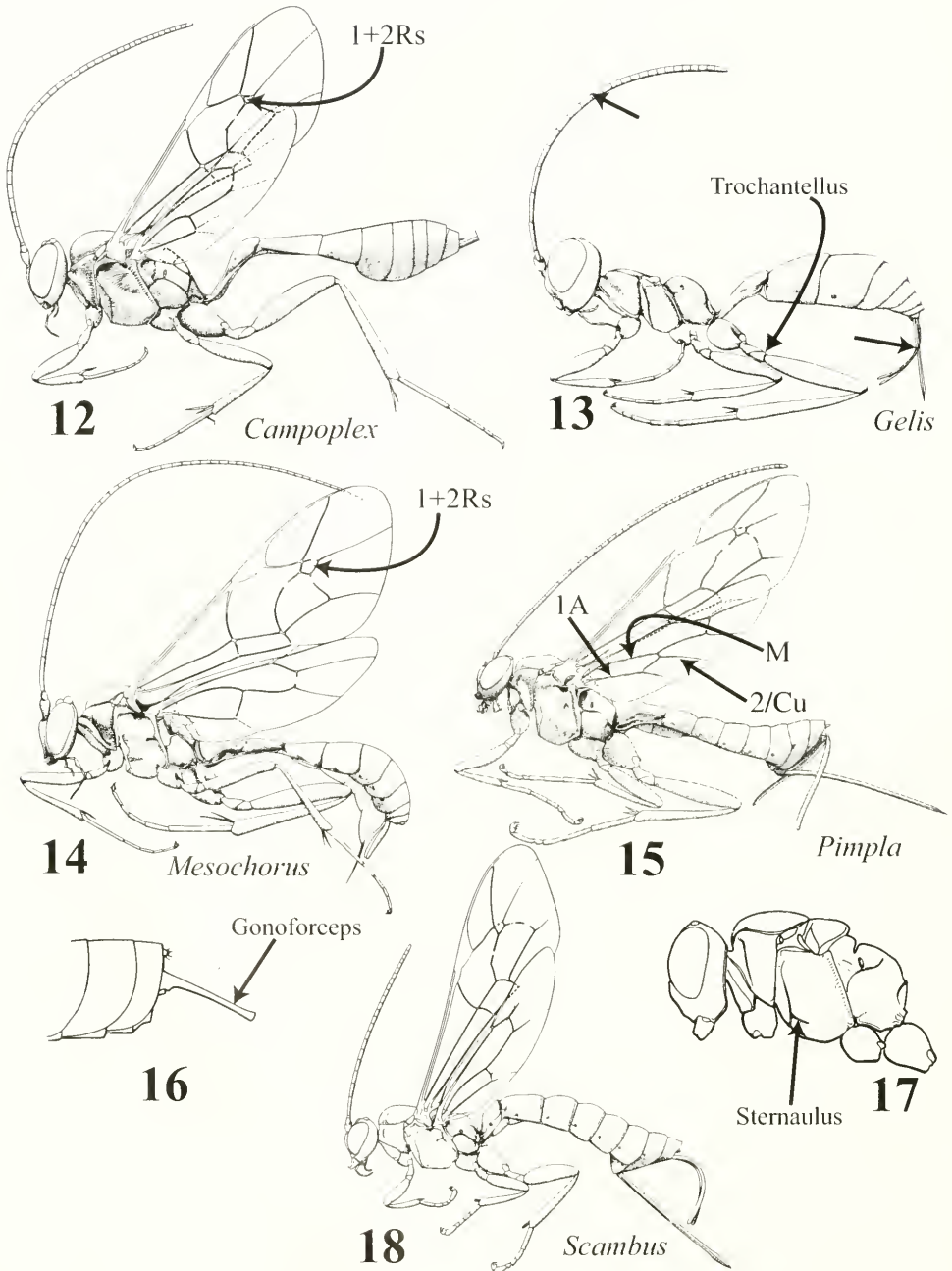

Figs. 12–18. 12–15, 18, Ichneumonidae, habitus: 12, *Campoplex* sp. 13, *Gelis* sp. 14, *Mesochorus* sp. 15, *Pimpla* sp. 18, *Scambus* sp. 16, *Mesochorus* sp., male gonoforceps. 17, Ichneumonoidea, sternaulus.

the genus as “*Coccygomimus*”, a result of his idiosyncratic system of nomenclature (see Wahl & Mason (1995) for details); *Pimpla*, however, is the correct name.

#### 4. Genus *Scambus* Hartig (Fig. 18)

*Diagnosis*.—Eye not emarginate opposite antennal socket. Supra-antennal area

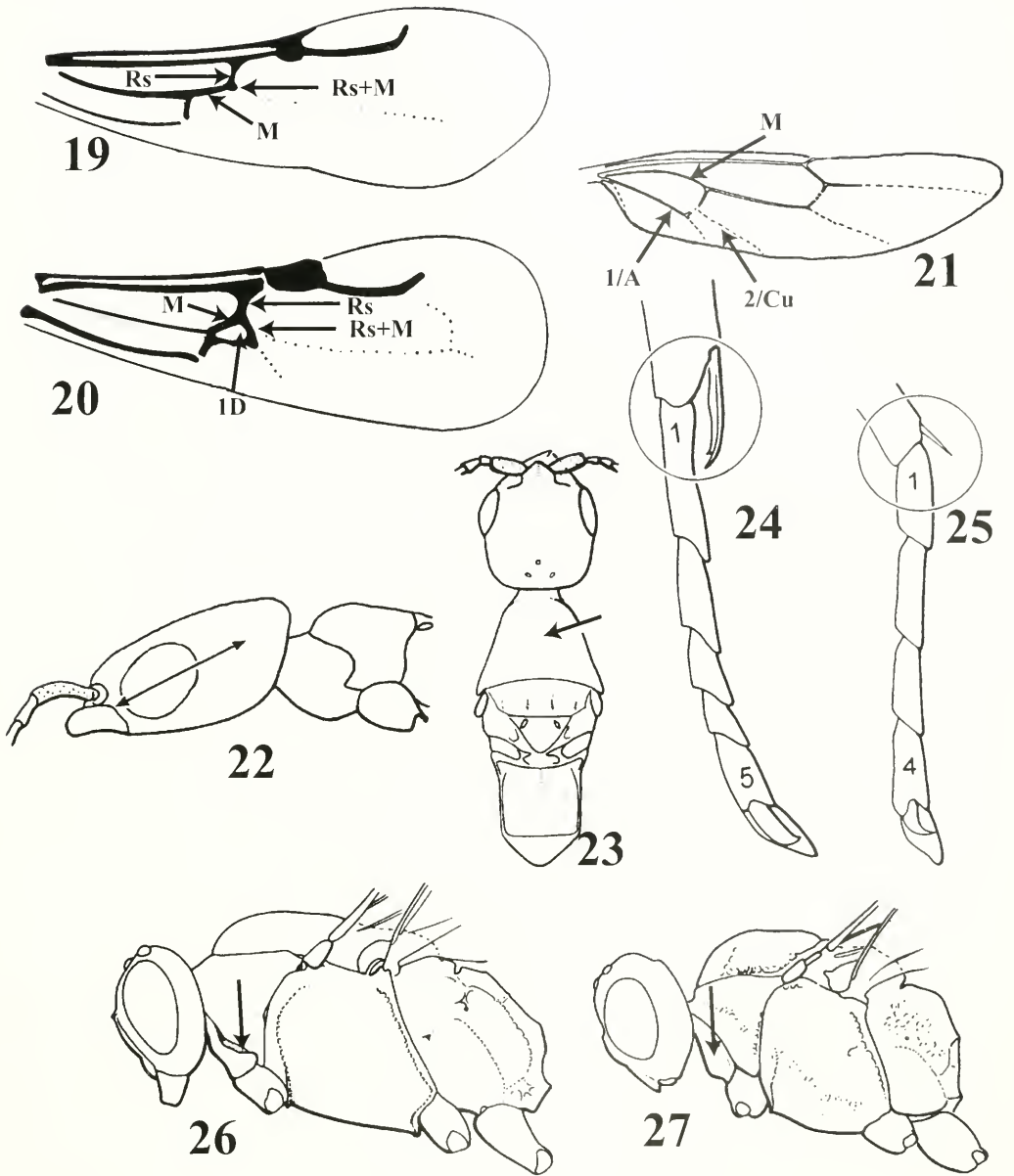

Figs. 19–27. 19–20, Bethyliidae: fore wings. 21, Ichneumonidae, hind wing. 22, Bethyliidae: prognathous head. 23, Bethyliidae, dorsal mesosoma. 24–25, Chalcidoidea, protarsi, 24, 5-segmented with a bifid spur. 25, 4-segmented with a straight spur. 26–27, Ichneumonidae, lateral mesosoma.

black. Pleural sulcus with distinct angulation opposite scrobe. Fore tarsal claw of female with large basal lobe. Hind tibia with apical and subapical dark bands, extreme base thus being pale. Vein 2-cu of hind wing meeting vein cu-a more or less

equidistant between veins M and 1A. Ovipositor tip straight, not abruptly down-curved.

*Notes.*—*Scambus* (*sensu* Fitton et al. 1988) is Holarctic and Neotropical in distribution. Nineteen species have been de-

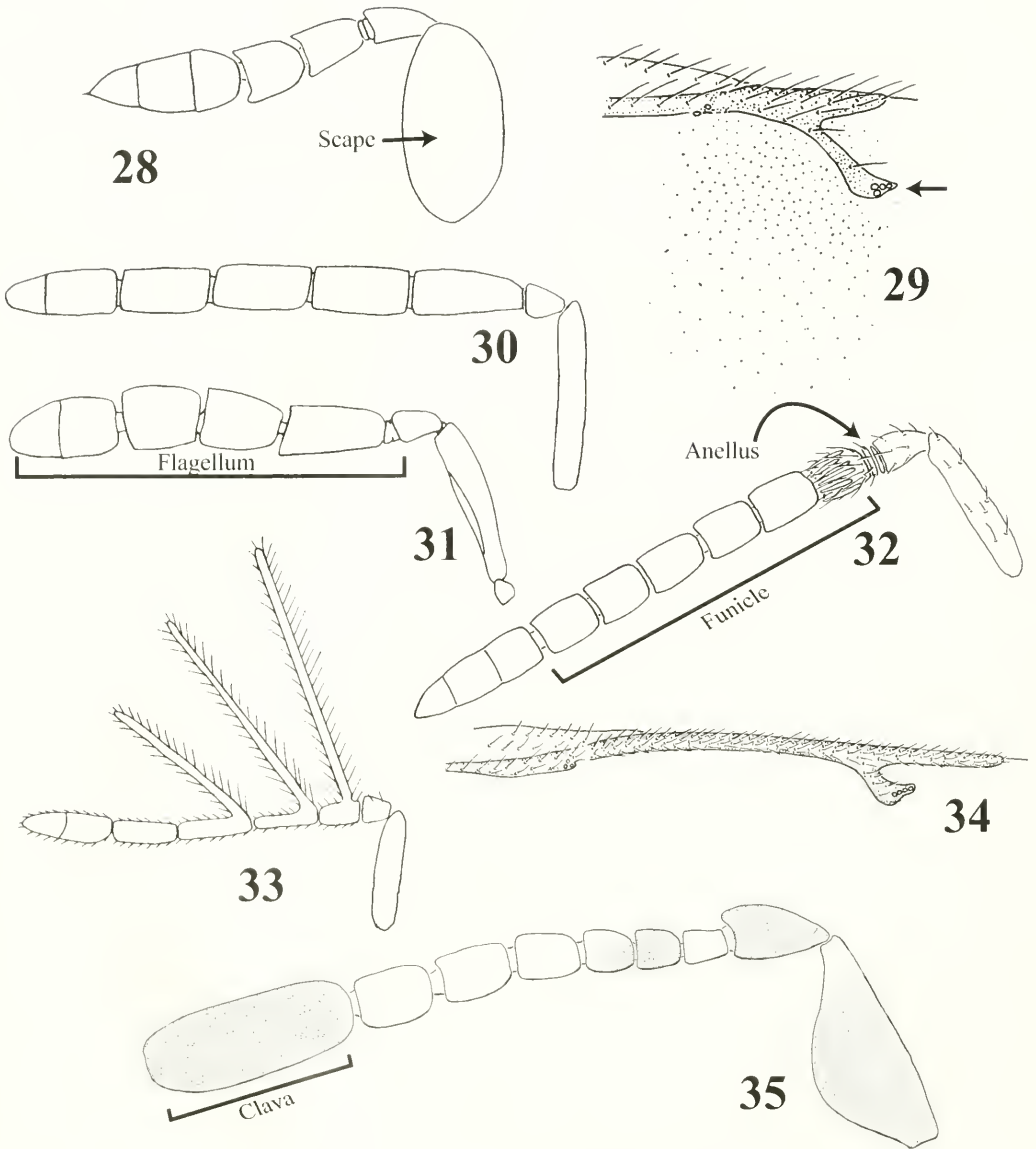

Figs. 28–35. 28, *Diatlinopsis callichroma*, male antenna. 29, *Parablastothrix nearctica*, fore wing venation. 30–31, *Sympiesis* sp., female: 30–31, antenna. male: 33, antenna. 32, *Thinodytes* sp., antenna. 34, *Brachymeria* sp., fore wing venation. 35, *Ageniaspis bicoloripes*, antenna.

scribed from the Nearctic, with 12 of these occurring in California (Carlson 1979). The species are idiobiont ectoparasitoids of the larvae, pre-pupae, or pupae of small Lepidoptera in buds, fruits, leaf rolls, and leaf mines.

#### Subfamily Campopleginae

#### 5. Genus *Campoplex* Gravenhorst (Figs. 12, 26)

*Diagnosis*.—Eye not emarginate opposite antennal socket. Propodeum with

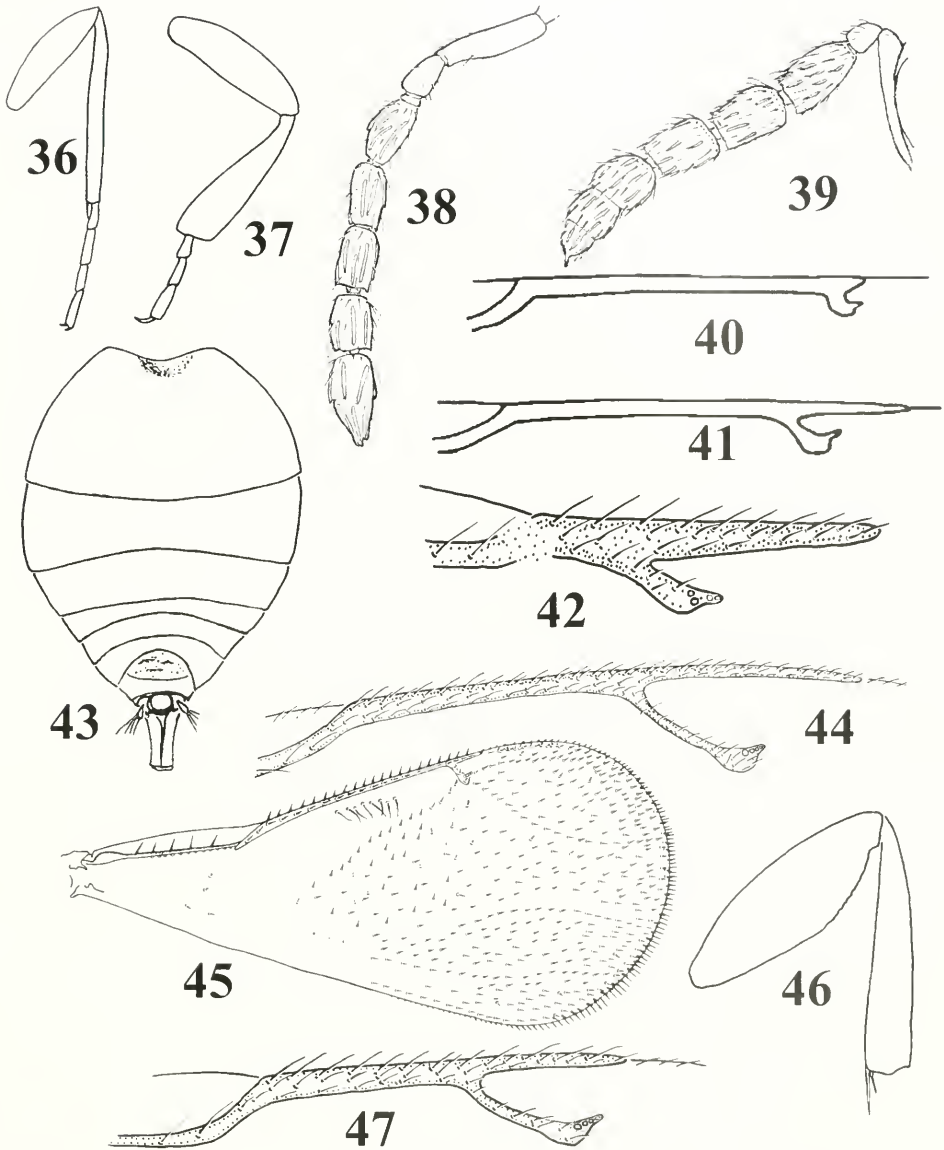

Figs. 36–47. 36–37, Chalcidoidea, hind legs. 38–39, *Pnigalio* sp., antenna. 40–41, Torymidae, fore wing venation. 42, *Ageniaspis bicoloripes* Girault, fore wing venation. 43, Torymidae, dorsal gaster. 44, *Mesopolobus* sp., fore wing venation. 45, *Euderus* sp., fore wing. 46, *Microdoutomerus* sp., hind leg. 47, *Trichomalopsis* sp., fore wing venation.

combined areola and petiolar area not forming a trough; apex of propodeum not reaching middle of hind coxa. Vein 2-cu of hind wing basally complete. Petiole of metasomal segment 1 cylindrical at basal 0.3 (not quadrate or trapezoidal in cross-section), suture separating tergite and ster-

nite at midheight, and sternite noticeably convex and produced. Glymma weak, present only as shallow groove. Ovipositor  $\sim 2.0\times$  as long as apical depth of metasoma. Male with apex of gonoforceps without semicircular notch.

*Notes.*—This large, cosmopolitan genus

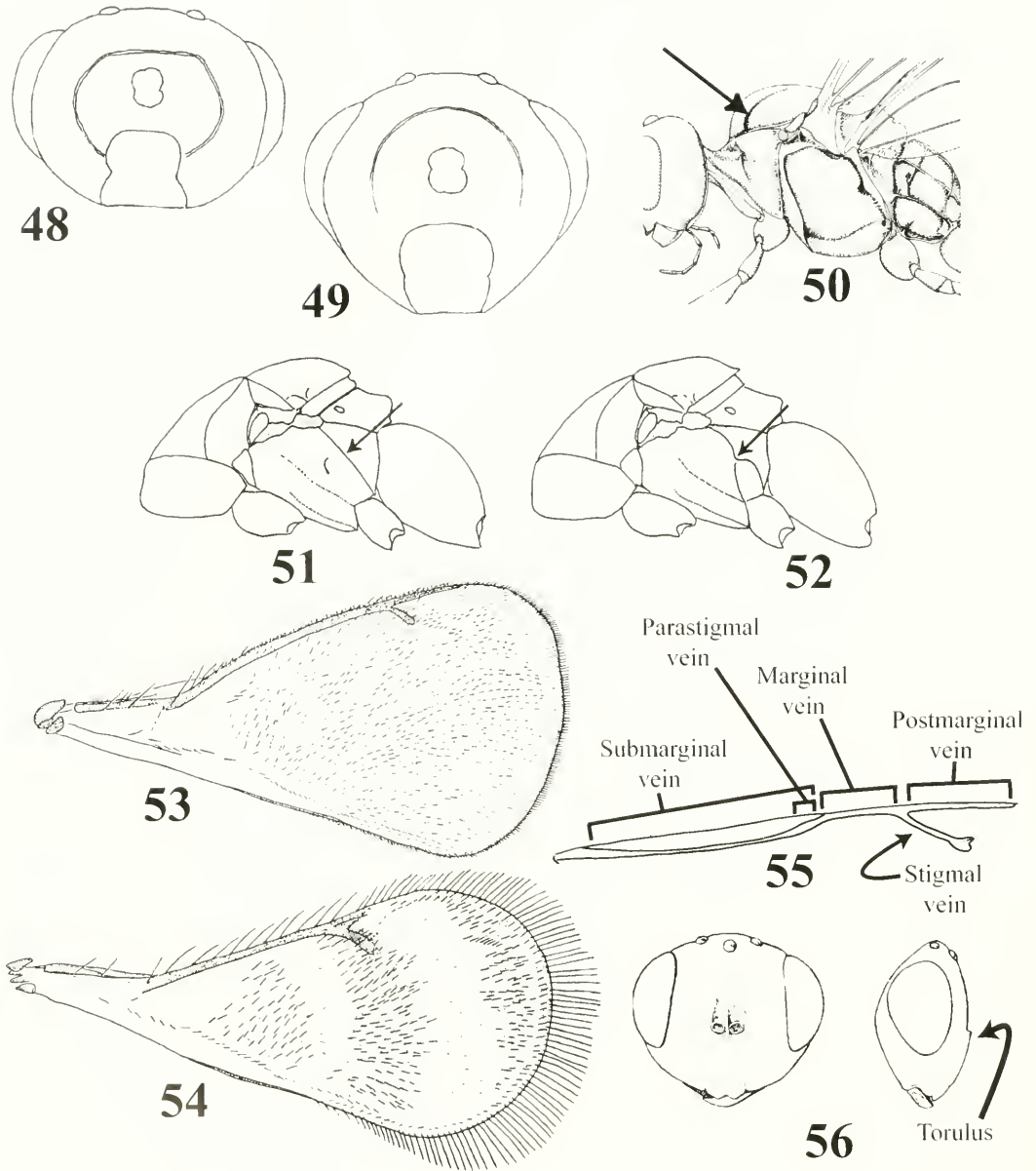

Figs. 48–56. 48–49, Torymidae, posterior head. 50, *Bathythrix* sp.: lateral mesosoma. 50–51, Toryimidae: 50, mesosoma with straight mesopleural-metapleural separation; 51, mesosoma with sinuous mesopleural-metapleural separation. 53, *Chrysocharis* sp.: fore wing, 54, *Closterocerus* sp.: fore wing. 55–56, *Pteromalus* sp.: 55, fore wing venation; 56, frontal and lateral head.

has 32 described species in the Nearctic region, with seven of these known from California (Carlson 1979, Townes 1970b); there are probably five times as many un-

described species. They are koinobiont endoparasitoids; the hosts are microlepidoptera that feed in concealment (such as leaf rolls, buds, and cases).

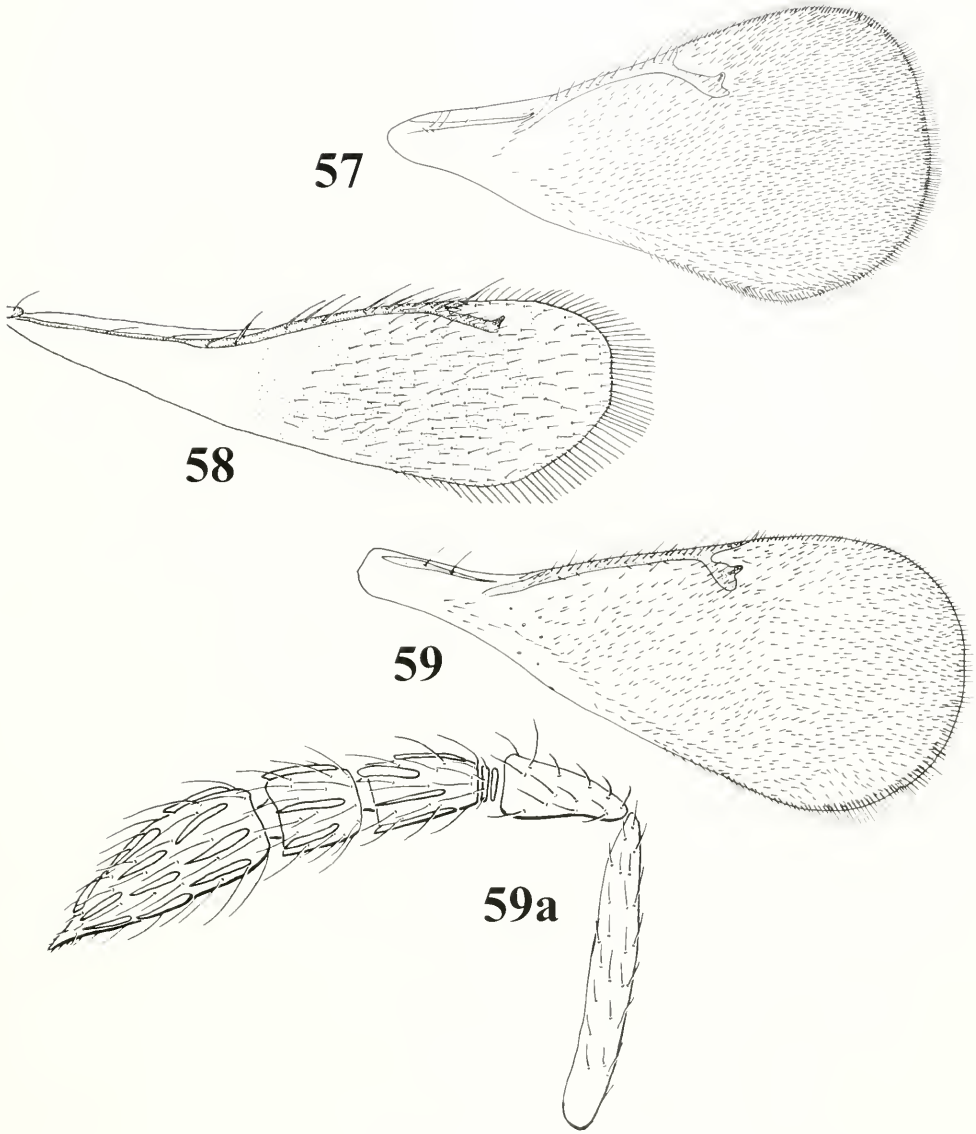

Figs. 57-59a. 57, *Baryscapus* sp., fore wing. 58, *Cirrospilus* n.sp., fore wing. 59, *Neochrysocharis* sp., fore wing. 59a, *Cirrospilus* n. sp., antenna.

Subfamily Cryptinae

6. Genus *Diaglyptidea* Viereck

*Diagnosis.*—Both sexes macropterous. Mandible without sub-basal swelling. Clypeus with apical 0.3 strongly inflexed and covered with brush of long setae; apex without denticles. Center of pronotum

with median longitudinal carina; lateral face with epomia. Mesoscutum with notaulus not reaching middle; surface matte. Cell 1+2Rs of fore wing open.

*Notes.*—This genus is found in the Holarctic and Neotropical regions and contains at least 22 species (Townes 1970a). The undescribed species reared in this

study is the first record from California. Host records are lacking; the wasps are presumably idiobiont ectoparasitoids.

### 7. Genus *Encrateola* Strand

*Diagnosis.*—Both sexes macropterous. Mandible without sub-basal swelling. Clypeus weakly convex and without brush of long setae; apex without denticles. Center of pronotum with median longitudinal carina; lateral face with epomia. Mesoscutum with notaulus not reaching middle; surface smooth to weakly matte. Cell 1+2Rs of fore wing closed.

*Notes.*—*Encrateola* is found worldwide except for Australia and contains at least 13 species (Townes 1970a). The undescribed species reared in this study is the first record from California. Host records are lacking; the wasps are presumably idiobiont ectoparasitoids.

### 8. Genus *Bathythrix* Foerster (Fig. 50)

*Diagnosis.*—Both sexes macropterous. Mandible without sub-basal swelling. Clypeus flat and without brush of long setae; apex with two strong median denticles. Center of pronotum without median longitudinal carina; lateral face with epomia. Mesoscutum with notaulus reaching beyond middle; surface polished. Cell 1+2Rs of fore wing closed.

*Notes.*—*Bathythrix* has a Holarctic distribution, with 25 species recorded from the Nearctic; only two are known from California (Townes 1983). Species in this genus attack small cocoons, including those of Braconidae and Ichneumonidae. They are idiobiont ectoparasitoids.

### Family BRACONIDAE

Readers are referred to Whitfield and Wagner (1991) for a key to the Holarctic genera of Braconidae known to parasitize leafminers. Reared braconids included in this study are only incorporated into Tables 1, 3.

Table 3. Families and genera of parasitic hymenoptera reared from native leafminers in California.

<b>BRACONIDAE*</b>	<b>EULOPHIDAE</b>
A. <i>Adelius</i>	14. <i>Diglyphus</i>
B. <i>Apanteles</i>	15. <i>Cirrospilus</i>
C. <i>Bassus</i>	16. <i>Zagrammosoma</i>
D. <i>Cantharoctonus</i>	17. <i>Diauliniopsis</i>
E. <i>Chelonus</i>	18. <i>Pnigalio</i>
F. <i>Colastes</i>	19. <i>Sympicis</i>
G. <i>Deuterixys</i>	20. <i>Hemiptarsenus</i>
H. <i>Dolichogenidea</i>	21. <i>Elachertus</i>
I. <i>Gnamptodon</i>	22. <i>Miotropis</i>
J. <i>Habrobracon</i>	23. <i>Baryscapus</i>
K. <i>Hormius</i>	24. <i>Aprostocetus</i>
L. <i>Mirax</i>	25. <i>Horismenus</i>
M. <i>Paradelius</i>	26. <i>Pediobius</i>
N. <i>Parahormius</i>	27. <i>Chrysocharis</i>
O. <i>Paroligoneurus</i>	28. <i>Achrysocharoides</i>
P. <i>Pholetesor</i>	29. <i>Neochrysocharis</i>
Q. <i>Rhysipolis</i>	30. <i>Closterocerus</i>
R. <i>Stiropius</i>	31. <i>Euderus</i>
S. <i>Viridipyge</i>	<b>EUPELMIDAE</b>
<b>ICHNEUMONIDAE</b>	32. <i>Eupelmus</i>
1. <i>Gelis</i>	33. <i>Brasema</i>
2. <i>Mesochorus</i>	<b>EURYTOMIDAE</b>
3. <i>Pimpla</i>	34. <i>Eurytoma</i>
4. <i>Scambus</i>	<b>PTEROMALIDAE</b>
5. <i>Campoplex</i>	35. <i>Callimerisus</i>
6. <i>Diaglyptidea</i>	36. <i>Thinodytes</i>
7. <i>Encrateola</i>	37. <i>Halticoptera</i>
8. <i>Bathythrix</i>	38. <i>Mauleus</i>
<b>BETHYLIDAE</b>	39. <i>Trichomalopsis</i>
9. <i>Goniozus</i>	40. <i>Mesopolobus</i>
<b>ENCYRTIDAE</b>	41. <i>Pteromalus</i>
10. <i>Ageniaspis</i>	42. <i>Spalangia</i>
11. <i>Parablastothrix</i>	<b>TORYMIDAE</b>
<b>CHALCIDIDAE</b>	43. <i>Microdontomerus</i>
12. <i>Conura</i>	44. <i>Torymus</i>
13. <i>Brachymeria</i>	

\* Taxa of Braconidae indicated by letters to separate from taxa which, indicated by numbers, are treated in the text.

### Superfamily Chrysoidea

#### Family BETHYLIDAE

#### Subfamily Bethylinae

### 9. Genus *Goniozus* Förster

(Figs. 19, 20, 22–23)

*Diagnosis.*—Predominantly black. Head and body dorsoventrally flattened, head prognathous (Fig. 22). Clypeus with strong angular/subangular median lobe, with median polished carina extending

between toruli. Propodeum margined laterally with complete, incomplete or absent transverse carina posteriorly connecting the lateral carinae. Tarsal claws of female bifid, those of male trifid.

*Notes.*—This cosmopolitan genus, with numerous described and undescribed species, primarily attacks microlepidopteran hosts. There are at least 36 species from the Nearctic and at least 30 from south of the United States (Evans 1978).

Superfamily Chalcidoidea  
Family ENCYRTIDAE  
Subfamily Encyrtinae

10. Genus *Ageniaspis* Dahlbom  
(Figs. 35, 42)

*Diagnosis.*—Tarsi 5-segmented. Funicle at least 6-segmented. Acropleuron swollen and mesocoxa inserted at or anterior to midline of mesopleuron (as in Fig. 61). Cercus usually placed near mid-length of gaster (as in Fig. 61). Clava 1-segmented, rounded (Fig. 35). Postmarginal vein  $>1.5\times$  as long as stigmal vein (Fig. 42). Scutellum longitudinally striate, appearing almost silky, in contrast to shallowly reticulate, shiny mesoscutum.

*Notes.*—A genus of 15 described species worldwide with 2 known from the Nearctic region (Miller 1961, Kazmi and Hayat 1998) and one species introduced against citrus leafminer (see Schauff et al. 1998 and references therein). Only *A. bicoloripes* is reported here to occur in California, while *A. citricola* will likely arrive on the heels of CLM. Members of this genus are primarily polyembryonic parasites of larvae of Lepidoptera. At the generic level, most of the host associations reported here are previously recorded (Noyes 1998) genera of the Gracillariidae (e.g. *Cameraria*, *Phyllonorycter*), with the exception of *Caloptilia* sp. (Gracillariidae) and *Stigmella* spp. (Nepticulidae).

11. Genus *Parablastothrix* Mercet  
(Figs. 29, 60–61)

*Diagnosis.*—Tarsi 5-segmented. Funicle at least 6-segmented. Acropleuron swollen

and mesocoxa inserted at or anterior to midline of mesopleuron (Fig. 61). Cercus usually placed near mid length of gaster. Eye very nearly touching base of mandible (Fig. 60). Fore wing infusate in middle  $\frac{1}{2}$  or less (Fig. 29).

*Notes.*—One described Nearctic species recorded from central and eastern USA, *P. nearctica* Miller (Miller 1965) and at least one unidentified species (Noyes et al. 1997). At least 16 nominal species worldwide which attack larvae of Lyonetiidae and Nepticulidae. The host *Stigmella variella* (Braun) (Nepticulidae) is newly reported here.

*Comments.*—Three other damaged and unidentifiable encyrtids, apparently belonging to neither *Ageniaspis* nor *Parablastothrix* (Zolnerowich, pers. comm.), were reared for this study.

Family CHALCIDIDAE  
Subfamily Chalcidinae

12. Genus *Comura* Spinola  
(Fig. 107)

*Diagnosis.*—Tarsi 5-segmented. Funicle 7-segmented. Hind femur enlarged, dentate ventrally. Gaster petiolate, petiole slightly transverse to very long (Fig. 107). Propodeum with spiracle oriented subvertically to nearly longitudinally.

*Notes.*—Keys are provided by Burks (1940) and Delvare (1992—keys to species groups and *side* group). At least 45 species occur north of Mexico. Hosts consist primarily of cocoons of Lepidoptera but some species attack Coleoptera, Hymenoptera, or are secondary parasites through Ichneumonoidea. New records reported here include rearings from the microlepidopteran families Tischeriidae, Gracillariidae and Elachistidae.

Subfamily Brachymeriinae

13. Genus *Brachymeria* Westwood  
(Figs. 102–105)

*Diagnosis.*—Tarsi 5-segmented. Funicle 7-segmented (Fig. 105). Hind femur en-

larged, dentate ventrally (Fig. 103). Gaster sessile, petiole in dorsal view not visible (Fig. 102) or evident as a transverse line. Propodeum with spiracle oriented diagonally (Fig. 104).

*Notes.*—Burks (1960) provided a key to Nearctic species. There are at least 25 species north of Mexico with 2–3 introduced taxa and six species known from California (Bouček 1992—key to species groups). Most species attack Lepidoptera, Diptera and Hymenoptera as primary parasites. Others are secondary parasites on Orthoptera and Lepidoptera through Tachinidae and Sarcophagidae. One species was reared from an unidentified leafminer on *Artemisia* sp. in this study.

Family EULOPHIDAE  
Subfamily Eulophinae

14. Genus *Diglyphus* Walker  
(Fig. 95)

*Diagnosis.*—Tarsi 4-segmented. Funicle 2-segmented. Submarginal vein with 3 or more setae dorsally; postmarginal vein at least as long as stigmal vein. Notauli incomplete; scutellum with lateral grooves (Fig. 95). Propodeum without median carina or plica (Fig. 95). Coloration dark metallic. Often confused with *Cirrospilus*, but *Cirrospilus* have complete notauli that reach the posterior margin of the mesoscutum (Fig. 95).

*Notes.*—Widespread and abundant genus with numerous species. Species of *Diglyphus* are mainly parasitic upon leaf-mining Diptera on herbaceous plants, but are also known from Lepidoptera on woody plants (Bouček and Askew 1968). Several species are important for biocontrol of Agromyzidae (LaSalle and Parrella 1991). Gordh and Hendrickson (1979) provide a key to species. Four species are reported north of Mexico and all four have been documented in California (Krombein et al. 1979). We record two new hosts for *Diglyphus*, one each in the families Elachistidae and Gracillariidae.

15. Genus *Cirrospilus* Westwood  
(Figs. 58, 59a, 114)

*Diagnosis.*—Tarsi 4-segmented. Funicle 2-segmented. Submarginal vein with 3 or more setae dorsally; postmarginal vein subequal in length to stigmal vein. Notauli complete to posterior margin of the mesoscutum; scutellum with lateral grooves that may be faint (cf. Fig. 102). Propodeum usually without median carina or plica. Coloration metallic to non-metallic and yellow. Wing rarely with infuscation (Fig. 58). Often confused with *Zagrammosoma*, but *Zagrammosoma* have the head vaulted (but also in *Cirrospilus coachellae* Gates) and the notauli turn to intercept the advanced axillae (cf. Fig. 108). The axillae are not advanced in most *Cirrospilus*. *Cirrospilus* resembles *Diglyphus*, but *Cirrospilus* have complete notauli that reach the posterior margin of the mesoscutum (Fig. 114).

*Notes.*—Over 300 nominal species worldwide, ~24 in North America (Noyes 1998), and at least five (Krombein et al. 1979, Gates 2000) found in California. Species range from parasitic, facultatively hyperparasitic or obligately hyperparasitic (rarely) to gregariously ectoparasitic on numerous cryptically-feeding hosts (Bouček 1959b, 1988, Schauff et al. 1997, Gates 2000). Key only available to the Palaearctic species (Bouček 1959b). Most of the new hosts we report for this genus belong to the Gracillariidae, but also in Lyonetiidae, Tischeriidae and Nepticulidae.

16. Genus *Zagrammosoma* Ashmead  
(Figs. 109, 108)

*Diagnosis.*—Tarsi 4-segmented. Funicle 2-segmented. Head vaulted, extending above dorsal margin of eye (Fig. 109). Submarginal vein with 3 or more setae dorsally; postmarginal vein subequal in length to stigmal vein. Notauli turning to intercept advanced axilla anteriorly (Fig. 108); scutellum with lateral grooves that may be faint (Fig. 108). Propodeum lack-

ing median carina (or only weakly indicated) or plica. Coloration yellow with variously produced longitudinal brown stripes. Wing often distinctly infusate. Commonly confused with *Cirrospilus* (see discussion under that genus).

*Notes.*—Primarily a New World genus that attacks leafmining Lepidoptera and Diptera (Gordh 1978, Bouček 1988, LaSalle 1989). Keys to ~10 Nearctic species may be found in Gordh (1978) and LaSalle (1989) with at least five species known from California (Krombein et al. 1979). New host family records are reported for the Gracillariidae, Elachistidae, Tischeriidae and Lyonetiidae.

#### 17. Genus *Diaulinopsis* Crawford (Fig. 28)

*Diagnosis.*—Tarsi 4-segmented. Funicle 2-segmented, male with enlarged scape (Fig. 28). Submarginal vein with 3 or more setae dorsally; postmarginal vein about twice as long as stigmal vein. Notauli complete and extending to transscutal articulation; scutellum without lateral grooves (as in Fig. 99). Propodeum without median carina or plica. Commonly confused with *Diglyphus* but *Diaulinopsis* lacks scutellar grooves.

*Notes.*—Gordh and Hendrickson (1979) provide a key to the two Nearctic species, one of which occurs in California. We record only one new host association, *Lirionmyza sativae* Blanchard (Agromyzidae), for *Diaulinopsis callichroma* Crawford.

#### 18. Genus *Pnigalio* Schrank (Figs. 38–39, 97–98)

*Diagnosis.*—Tarsi 4-segmented. Funicle 4-segmented (rarely 3-segmented) (Figs. 38–39). Submarginal vein with 3 or more setae dorsally; postmarginal vein present, longer than stigmal vein. Notauli incomplete (Fig. 97); scutellum sculptured, lacking lateral grooves. Propodeum glabrous with complete median carina, plica, and usually costula (Fig. 98). This genus may be confused with *Sympiesis*, which shares

4 funicular segments, incomplete notauli, and the scutellum lacks sublateral grooves, but the plicae and costulae of *Pnigalio* distinguishes it from *Sympiesis*.

*Notes.*—This genus is primarily Holarctic containing typically polyphagous parasitoids of leafmining and gall-forming insects, usually Lepidoptera. Also documented from Diptera and Coleoptera (Miller 1970, Yoshimoto 1983). Approximately 17 species occur in the Nearctic region with seven of these known from California (Krombein et al. 1979, Yoshimoto 1983, Noyes 1998). Numerous new specific host records are presented here from following lepidopteran families: Tischeriidae, Lyonetiidae, Gracillariidae, Momphidae and Heliozelidae.

#### 19. Genus *Sympiesis* Förster (Figs. 30–31, 33, 99)

*Diagnosis.*—Tarsi 4-segmented. Funicle 4-segmented. Submarginal vein with 3 or more setae dorsally; postmarginal vein present, longer than stigmal vein. Notauli incomplete (Fig. 99); scutellum sculptured, lacking lateral grooves. Propodeum glabrous with complete median carina, lacking plica and costula. This genus may be confused with *Pnigalio*, which shares 4 funicular segments, incomplete notauli, and the scutellum lacking sublateral grooves, but lacks the plica and (usually) costula possessed by *Pnigalio*.

*Notes.*—Four of the twenty nominal species known from the Nearctic region occur in California (Noyes 1998). Species of this genus are solitary or gregarious parasitoids of cryptically-feeding hosts, usually Lepidoptera (Bouček 1959a, Miller 1970, Storozheva 1982). Many species are presented here as new host associations, the majority belonging to the Gracillariidae and Tischeriidae.

#### 20. Genus *Hemiptarsenus* Westwood (Fig. 90)

*Diagnosis.*—Tarsi 4-segmented. Funicle 4-segmented. Submarginal vein with 3 or

more setae dorsally; postmarginal vein present, longer than stigmal vein. Notauli incomplete. Torulus situated above lower eye margin, thus scape extends beyond level of vertex.

*Notes.*—Two of the 17 nominal species known from the Nearctic region also occur in California (Noyes 1998, also see Schauff and LaSalle 1993). All known hosts are leafminers, typically Diptera. The wasps recovered in this study were associated with species of *Phyllonorycter* (Gracillariidae) on *Q. chrysolepis*.

#### 21. Genus *Elachertus* Spinola (Figs. 100–101)

*Diagnosis.*—Tarsi 4-segmented. Funicle 4-segmented. Submarginal vein with 3 or more setae dorsally; postmarginal vein present, longer than stigmal vein. Notauli complete (Fig. 100); scutellum with lateral grooves that converge posteromedially. Propodeum with complete median carina, lacking plicae (Fig. 101).

*Notes.*—The six Nearctic species in this genus are often polyphagous on small larvae of Lepidoptera in concealed situations (Schauff 1985, Bouček 1988). Three of these species are widely distributed in the Nearctic, with two documented from California. All hosts presented here are previously unknown for this genus and belong to the lepidopteran families Gracillariidae and Tischeriidae.

#### 22. Genus *Miotropis* Thomson (Fig. 96)

*Diagnosis.*—Tarsi 4-segmented. Funicle 4-segmented. Submarginal vein with 3 or more setae dorsally; postmarginal vein present, longer than stigmal vein. Notauli incomplete (Fig. 96); scutellum sculptured, lacking lateral grooves, but if lateral grooves present they do not or only slightly converge posteromedially. Propodeum glabrous with complete median carina, lacking plica and costula (Fig. 111). This genus may be confused with *Pnigalio*, which shares 4 funicular segments, incom-

plete notauli and the scutellum lacks sub-lateral grooves, but *Miotropis* lacks the plica and (usually) costula possessed by *Pnigalio*. It may also be confused with *Elachertus*, but the submedial grooves on the scutellum converge posteromedially (often contacting each other) in *Elachertus*.

*Notes.*—This genus contains at least nine species in the Nearctic region that are known to attack Lepidoptera (see Schauff and LaSalle 1993) and at least one species occurs in California (Noyes 1998). All hosts presented here are previously unknown for this genus and belong to Gracillariidae and Tischeriidae.

#### Subfamily Tetrastichinae

#### 23. Genus *Baryscapus* Förster (Figs. 57, 93–94)

*Diagnosis.*—Tarsi 4-segmented. Funicle 3-segmented. Submarginal vein with 2 or more setae dorsally; postmarginal vein reduced or absent. Notauli complete; mid-lobe of mesoscutum with several scattered setae or with adnotaular row of setae; scutellum with 2 pairs of setae and 2 pairs of longitudinal grooves. Propodeal spiracle with entire rim exposed (Fig. 93). Gaster with longest 2 cercal setae subequal in length with each other and with surrounding gastral setae, straight or slightly curved (Fig. 94). This genus may be confused with *Aprostocetus*, which differs in having the raised lobe of the callus partially covering the outer rim of the spiracle (Fig. 91), and the cercal setae not all subequal, one distinctly longer and sinuate (Fig. 92).

*Notes.*—This genus contains many species in the Holarctic region that may be parasitoids or hyperparasitoids (Graham 1991, LaSalle 1994), and it is unknown how many species actually occur in California. Two new hosts in the Cosmopterigidae and Tischeriidae are reported as new.

24. Genus *Aprostocetus* Westwood  
(Figs. 91–92)

*Diagnosis*.—Tarsi 4-segmented. Funicle 3-segmented (4-segmented in male). Submarginal vein with 2 or more setae dorsally; postmarginal vein reduced or absent, less than a third as long as stigmal vein. Notauli complete; midlobe of mesoscutum with a single adnotaular row of setae; scutellum with 2 pairs of setae and 2 pairs of longitudinal grooves. Propodeum with raised lobe of callus overhanging outer rim of spiracle (Fig. 91). Gaster with cercal setae not all subequal, one distinctly longer and sinuate (Fig. 92). This genus may be confused with *Baryscapus*, see discussion under that genus.

*Notes*.—This genus is cosmopolitan and abundant with hundreds of species that have a wide host range (Graham 1987, Bouček 1988, LaSalle 1994), and it is unknown how many occur in California. New host species recorded herein include members of Tischeriidae, Gracillariidae, and Lyonetiidae.

Subfamily Entedoninae

25. Genus *Horismenus* Walker  
(Figs. 84–85)

*Diagnosis*.—Tarsi 4-segmented. Funicle 3-segmented (4 in male). Submarginal vein with 2 setae dorsally; postmarginal vein shorter than stigmal vein. Anterior margin of pronotum with carina; notauli incomplete; scutellum with median groove (Figs. 84–85); propodeum with median carina bordered by depressed and often sculptured area (Fig. 85). May be confused with other 'hard-bodied' entedonines such as *Pediobius*, but the propodeal sculpture is unique (Fig. 85).

*Notes*.—Primarily a New World genus with at least 17 Nearctic species of which at least two are known from California (Noyes 1998). Species of *Horismenus* are parasitic or hyperparasitic (facultative or obligate) on a wide range of hosts (Burks 1971). The species of *Horismenus* recorded

here include new host associations for leafmining members of Tischeriidae and Gracillariidae.

26. Genus *Pediobius* Walker  
(Fig. 86)

*Diagnosis*.—Tarsi 4-segmented. Funicle 3-segmented. Submarginal vein with 2 setae dorsally; postmarginal vein subequal to stigmal vein. Anterior margin of pronotum with carina; notauli incomplete; scutellum lacking median groove (Fig. 86); propodeum with paired, posteriorly-divergent median carinae (Fig. 86), with lateral plica. Petiole present and distinct (cf. Fig. 80). May be confused with other 'hard-bodied' entedonines such as *Horismenus*, but its propodeal sculpture is unique (Fig. 86).

*Notes*.—Primarily an Old World genus, species of *Pediobius* are parasitic or hyperparasitic on a wide range of hosts (Bouček 1965, Kerrich 1973, Peck 1985). Approximately 39 Nearctic species are described with at least two documented from California (Noyes 1998). The *Pediobius* reared in this study were associated with Heliozelidae and Agromyzidae.

27. Genus *Chrysocharis* Förster  
(Figs. 53, 87)

*Diagnosis*.—Tarsi 4-segmented. Funicle 3-segmented (4-segmented in male). Submarginal vein with 2 setae dorsally; postmarginal vein at least 1.5× as long as stigmal vein (Fig. 53). Frontofacial suture V-shaped, rarely transverse; scutellum lacking median groove, with 1 pair of setae (Fig. 87); propodeum usually lacking plicae, incomplete median carina sometimes present. Distinguished from other genera of Entedoninae by the postmarginal vein 1.5× as long as the stigmal vein (Fig. 53).

*Notes*.—A speciose Holarctic genus with 64 species known from the Nearctic and a host range spanning the Diptera, Lepidoptera, Coleoptera and Hymenoptera (Hansson 1985a, 1987). All of the new associations reported here for *Chrysocharis* are

primarily in the families Agromyzidae, Gracillariidae and Elachistidae.

28. Genus *Achrysocharoides* Girault  
(Figs. 88–89, 116)

*Diagnosis*.—Tarsi 4-segmented. Funicle 3-segmented. Submarginal vein with 2 setae dorsally; postmarginal vein at most as long as stigmal vein; stigmal vein lacking radiating setal lines (as in Fig. 59). Frontofacial suture straight, transverse (Fig. 89); mesoscutum and scutellum often pitted (Fig. 88); scutellum lacking median groove, with 1 pair of setae; propodeum lacking plicae and median carina (Fig. 116). *Achrysocharoides* is most commonly confused with other possibly closely related genera: *Neochrysocharis* and *Closterocerus*. All three genera lack a median carina and plica on the propodeum, lack a transverse carina on the pronotum, lack a clypeal suture, and have the postmarginal vein at most as long as the stigmal vein. However, *Neochrysocharis* has the frontofacial sutures V- or Y-shaped (as in Fig. 110) and the mesosoma is never pitted dorsally, while *Closterocerus* has a single radiating line of setae extending from the stigmal vein and has the wing often with infuscate bands (Fig. 54), and is never pitted dorsally. Those specimens of *Achrysocharoides* reared from California leafminers possess mesh-like reticulation, lack the dorsal pitting and are most easily separated by the straight frontofacial suture.

*Notes*.—This cosmopolitan genus attacks small leafmining Lepidoptera (Yoshimoto 1977, Bryan 1980, Hansson 1985b, Kamijo 1990, 1991). Eighteen Nearctic species are known with one species (*A. zwoelferi* (Delucchi)) reported from British Columbia, Canada and one new California record for *A. villosus* Kamijo presented here. All new host associations for this genus are restricted to members of the Gracillariidae.

29. Genus *Neochrysocharis* Kurdjumov  
(Figs. 59, 115)

*Diagnosis*.—Tarsi 4-segmented. Funicle 2-segmented. Submarginal vein with 2 se-

tae dorsally; postmarginal vein shorter than stigmal vein (Fig. 59). Frontofacial sutures shaped like a "V"; mesoscutum and scutellum never pitted; scutellum with 1 pair of setae; propodeum lacking plicae and median carina. Mesopleuron with transepimeral sulcus strongly arched (Fig. 115). Fore wing lacking line of setae radiating apically from stigma.

*Notes*.—Hansson (1995) provides a key to the 18 species north of Mexico, but 24 nominal taxa are reported by Noyes (1998) as occurring in the Nearctic region with five of these in California. This genus is known from hosts in the Coleoptera, Diptera, Hymenoptera, and Lepidoptera. New host associations for this genus include members of the Agromyzidae, Gracillariidae, Tischeriidae and Heliozelidae.

30. Genus *Closterocerus* Westwood  
(Figs. 54, 110–111, 117)

*Diagnosis*.—Tarsi 4-segmented. Funicle 2-segmented. Submarginal vein with 2 setae dorsally; postmarginal vein shorter than stigmal vein (Fig. 54). Frontofacial sutures shaped like a "V" (Fig. 110); mesoscutum and scutellum never pitted; scutellum with 1 pair of setae; propodeum lacking plicae and median carina. Mesopleuron with transepimeral sulcus weakly arched (Fig. 117) or straight. Fore wing with a single line of setae radiating apically from stigma (Fig. 54).

*Notes*.—Hansson (1994) provides a key to 21 species in the Nearctic region. Of these, nine are known from California. Members of this genus attack a wide variety of insects: Coleoptera, Hemiptera (Psyllidae), leaf mining Diptera, Lepidoptera, and Hymenoptera as well as the eggs of Symphyta. New host associations presented here represent five families of microlepidoptera: Lyonetiidae, Gracillariidae, Tischeriidae, Elachistidae and Cosmopterigidae.

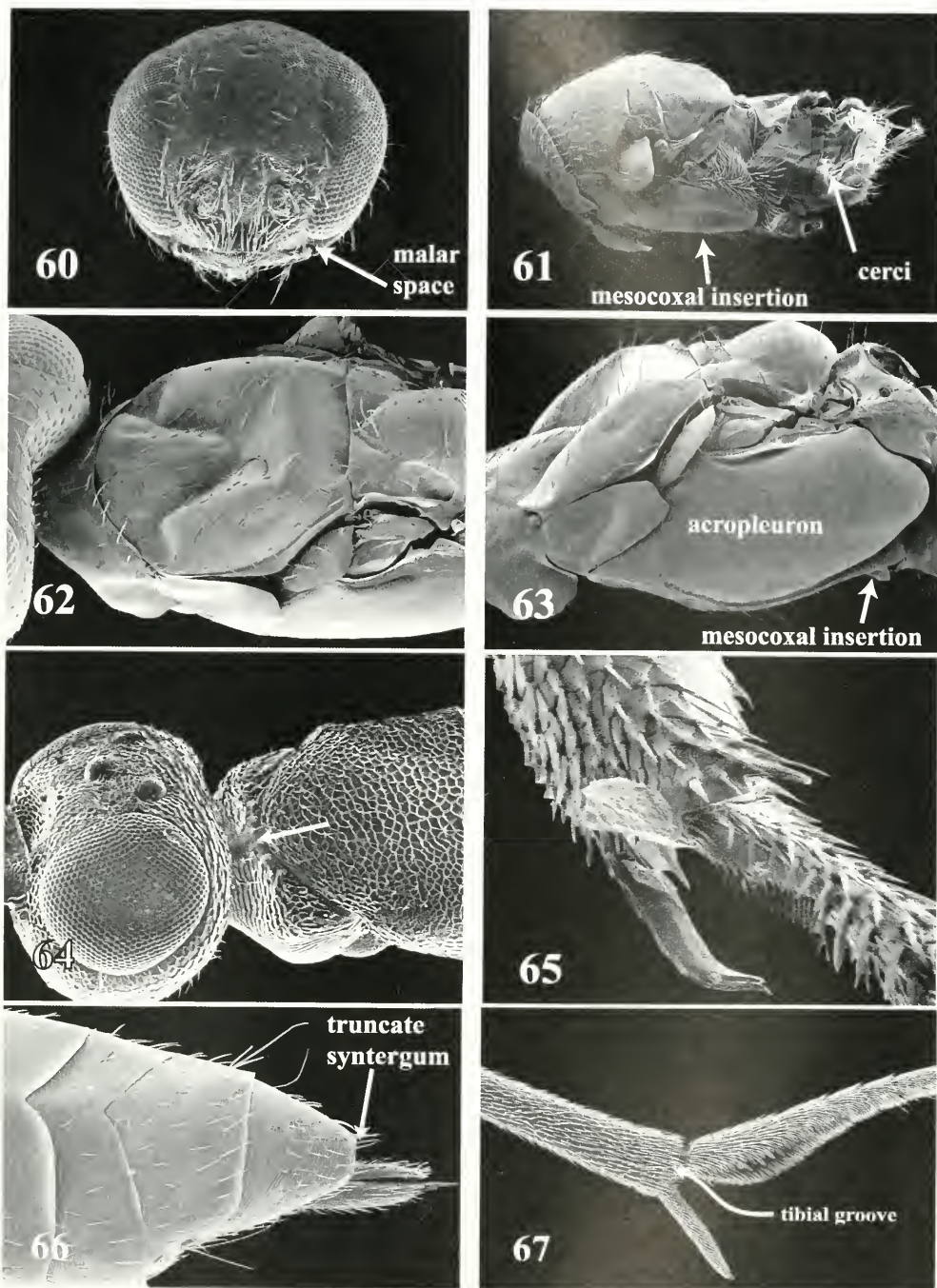

Figs. 60–67. 60–61, *Parablattothrix nearctica*: 60, face. 61, lateral mesosoma. 62–65, *Eupelmus* sp., female: 62, dorsal mesosoma. 63, lateral mesosoma, male. 64, dorsal pronotum. 65, apex of protibia. 66–67, *Brasema* sp.: 66, dorsal gaster. 67, mesotarsus.

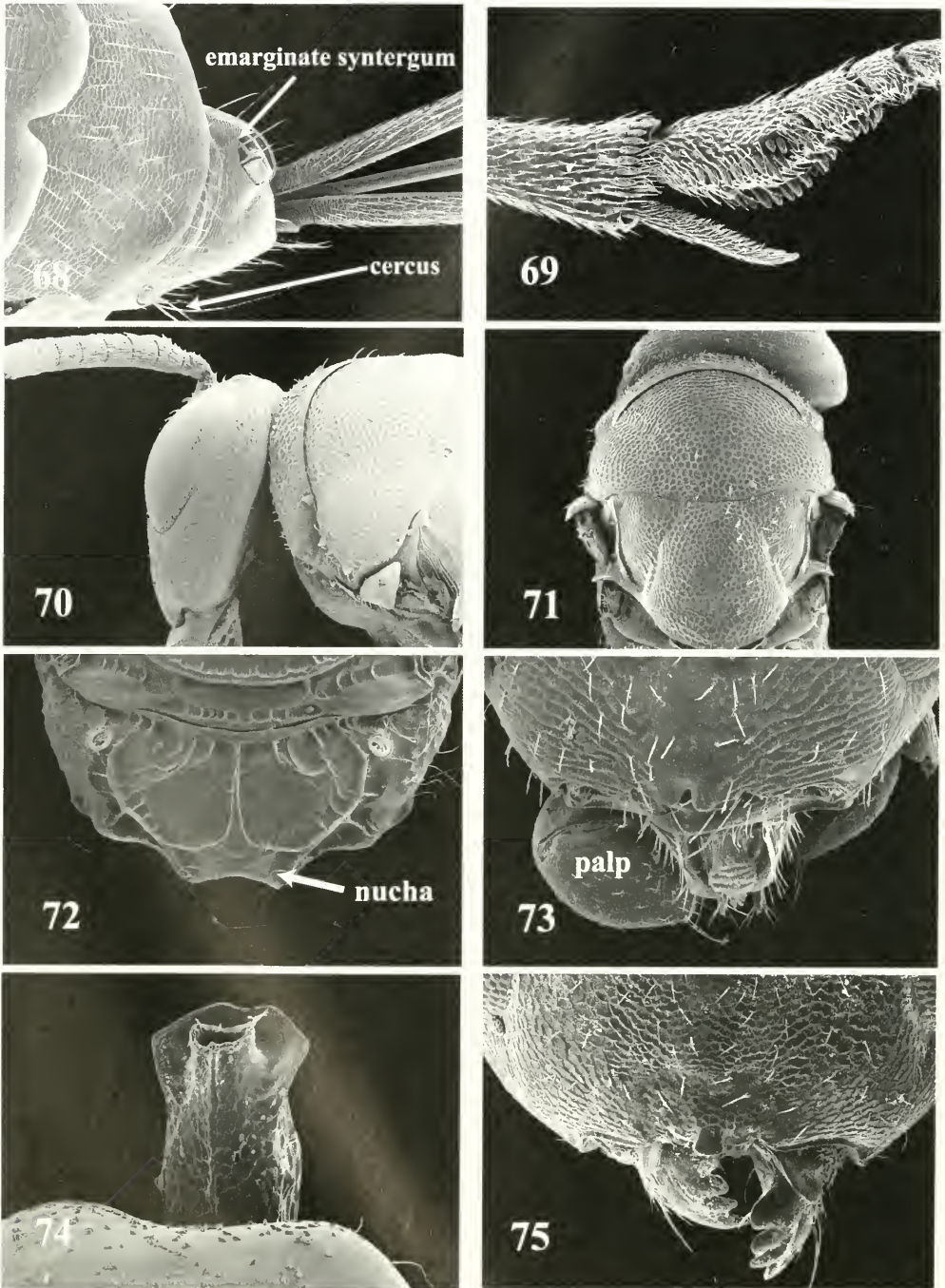

Figures 68–75. 68–69, *Eupelmus* sp.: 68, apex of gaster. 69, mesotarsus. 70–71, *Pteromalus* sp.: 70, lateral head and pronotum. 71, dorsal mesosoma. 72–74, *Halticoptera* sp., male: 72, propodeum. 73, clypeus and palps. 74, dorsal petiole. 75, *Thinodytes* sp., clypeus.

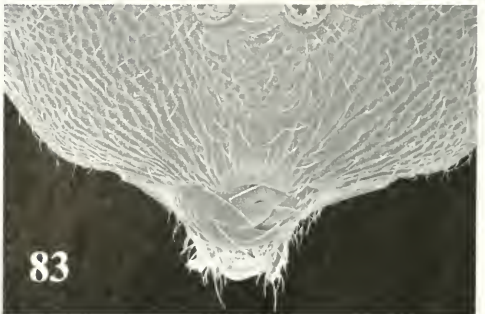
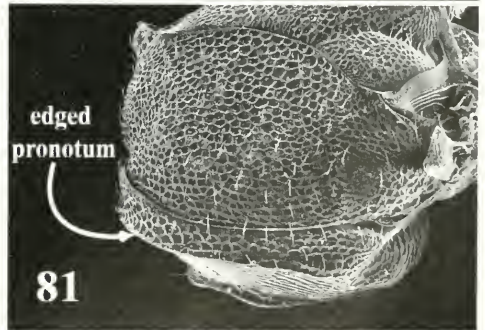
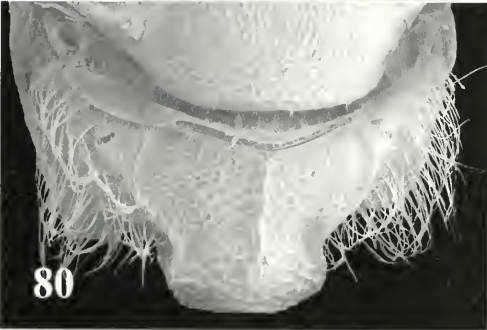
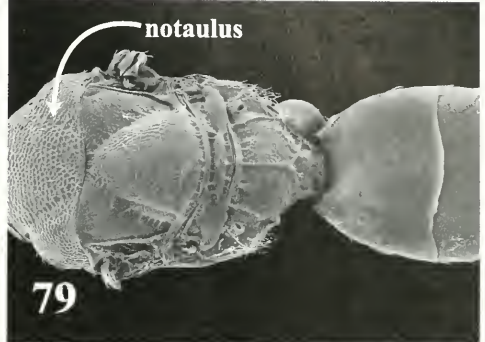
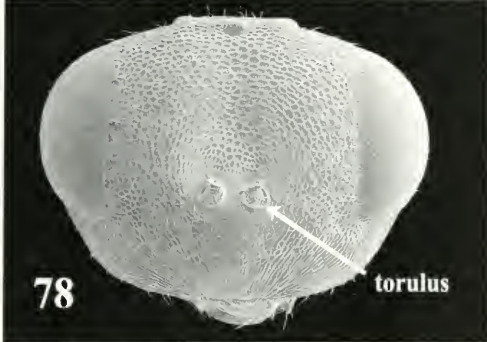
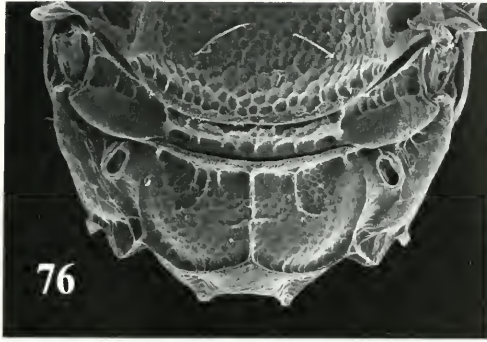

Figs. 76–83. 76–77, *Thinodytes* sp.: 76, propodeum. 77, dorsolateral petiole. 78–81, *Mesopolobus* sp.: 78, face. 79, dorsal mesosoma and gaster. 80, propodeum. 81, anterolateral mesosoma. 82, *Mauleus* sp., face. 83, *Pteromalus* sp., clypeus.

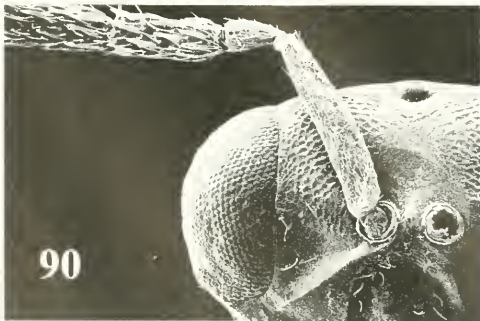
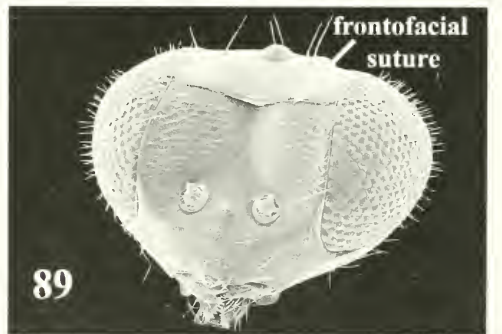
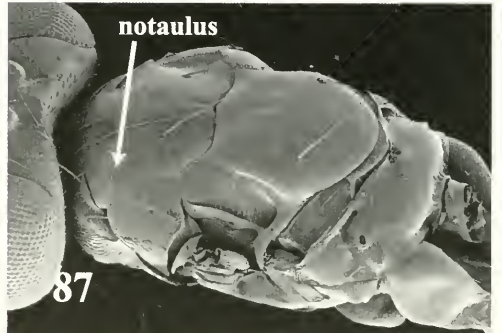
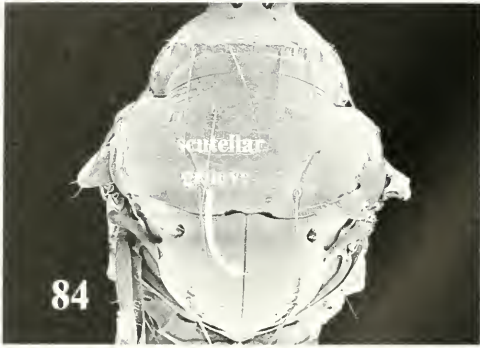

Figs. 84-91. 84-85, *Horismenus* sp.: 84, dorsal mesosoma. 85, propodeum. 86, *Pediobius* sp., propodeum. 87, *Chrysocharis* sp., dorso-lateral mesosoma. 88-89, *Achrysocharoides* sp.: 88, dorsal mesosoma. 89, face. 90, *Hemiptarsenus* sp., face. 91, *Aprostocetus* sp., scutellum.

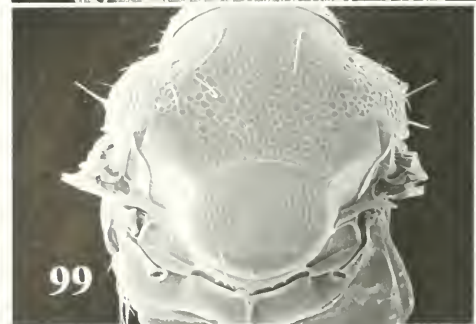
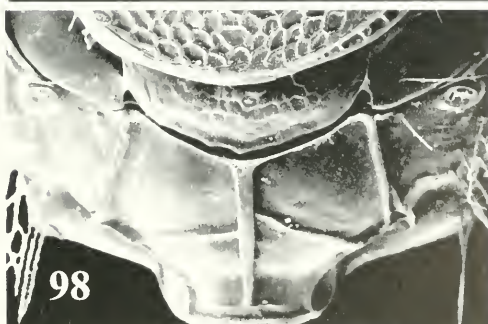
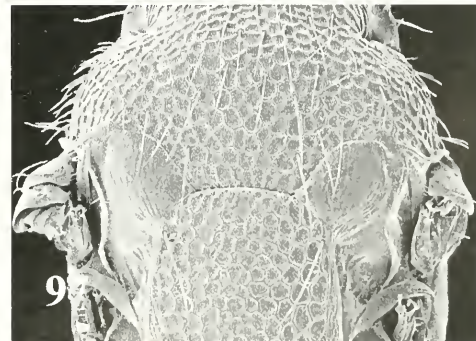
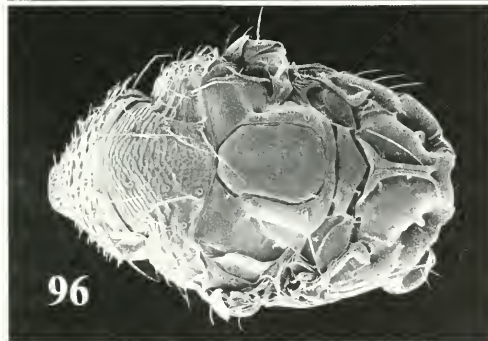
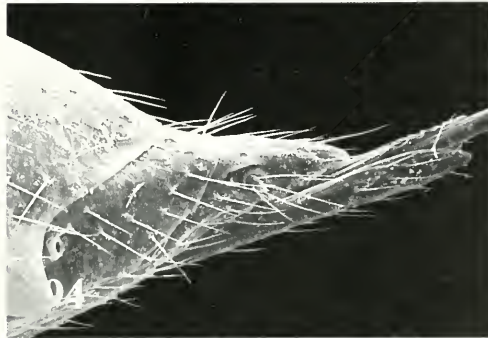
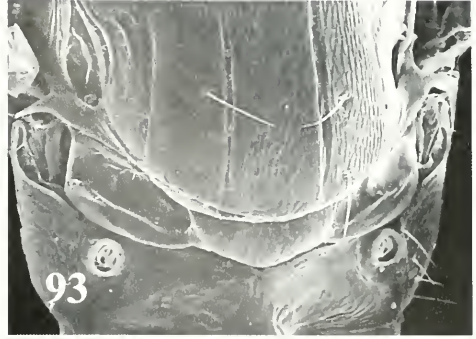
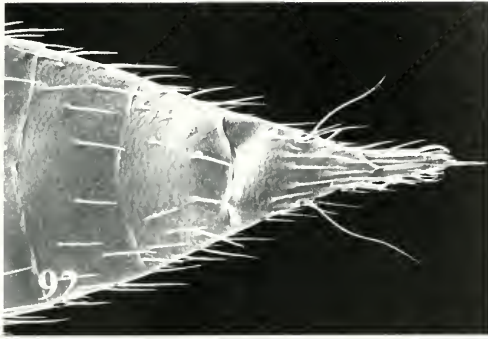

Figs. 92-99. 92, *Aprostocetus* sp., gaster apex, dorsal view. 93-94, *Baryscapus* sp.: 93, scutellum. 94, gaster apex, lateral view. 95, *Diglyphus* sp., dorsal mesosoma. 96, *Miotropis* sp., dorsal mesosoma. 97-98, *Pnigalio* sp.: 97, dorsal mesosoma. 98, propodeum. 99, *Sympiesis* sp., dorsal mesosoma.

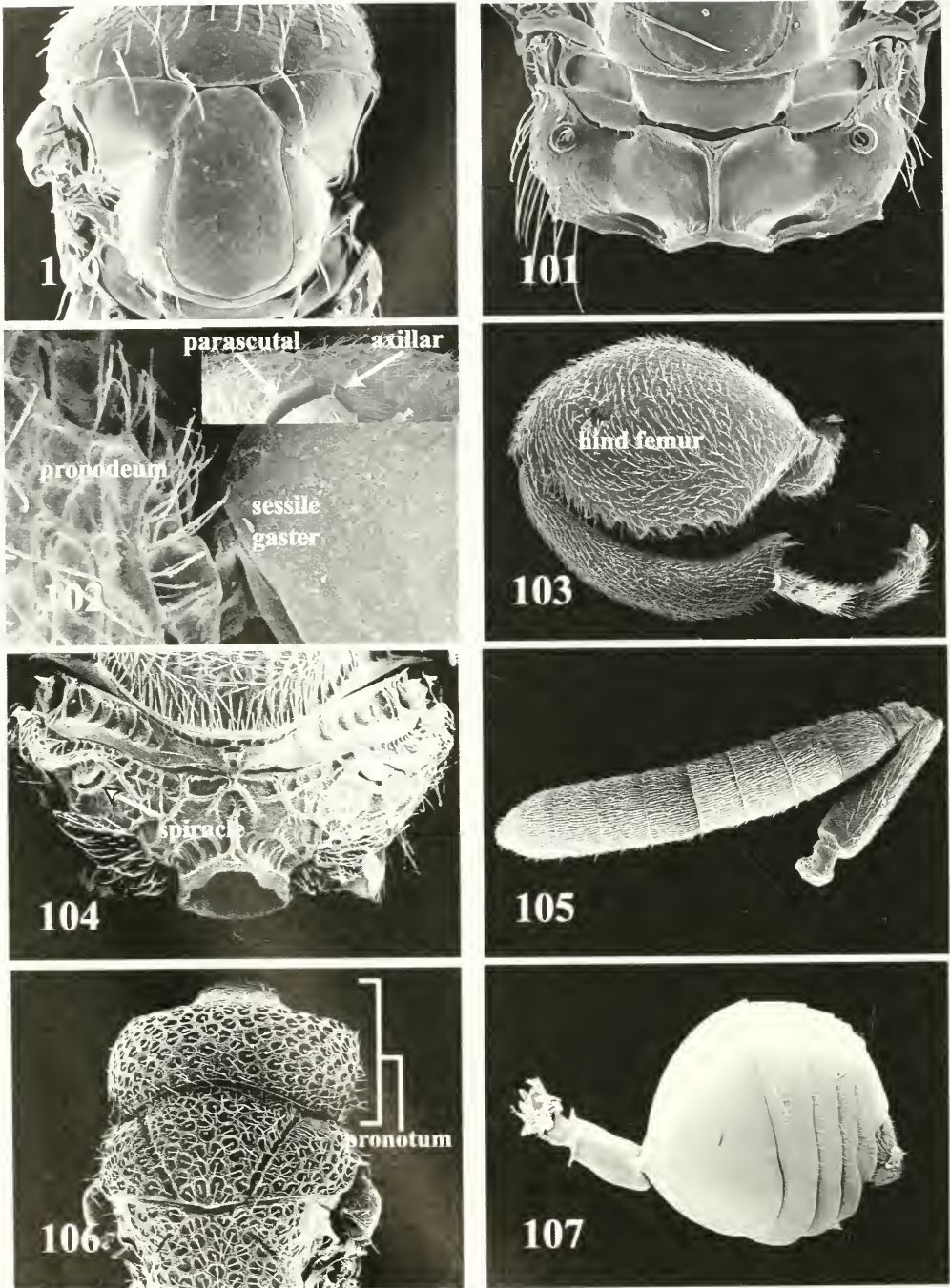

Figs. 100–107. 100–101, *Elachertus* sp.: 100, dorsal mesosoma. 101, propodeum. 102–105, *Brachymeria* sp.: 102, lateral view petiole; inset: junction parascutal and axillar carinae above wing base. 103, hind leg. 104, propodeal spiracle. 105, antenna. 106, *Eurytoma* sp., anterior mesosoma, dorsal view. 107, *Conura* sp., lateral gaster.



108



109

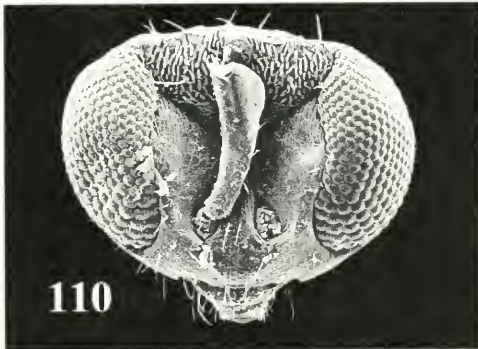

110



111



112

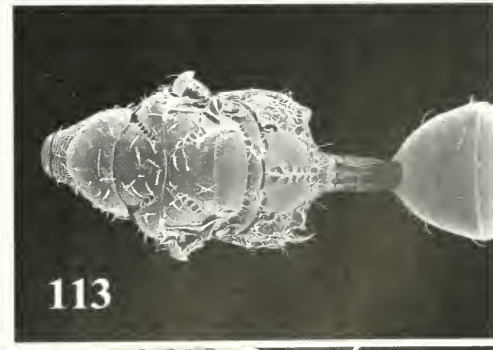

113

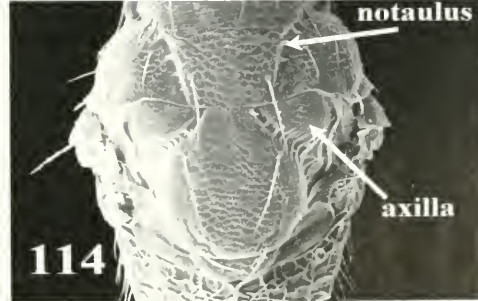

114

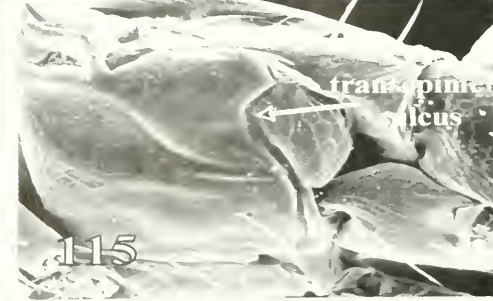

115

Figs. 108–115. 108–109, *Zagrammosoma* sp.: 108, dorsal mesosoma. 109, face. 110–111, *Closterocerus* sp.: 110, face. 111, dorsal mesosoma. 112–113, *Spalangia* sp.: 112, face. 113, dorsal mesosoma and gaster. 114, *Cirrospilus* sp., dorsal mesosoma. 115, *Neochrysocharis* sp., lateral mesosoma.

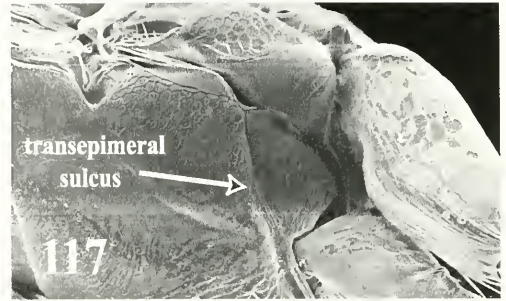

Fig. 116–117. 116, *Achrysocharoides* sp., propodeum. 117, *Closterocerus* sp., lateral mesosoma.

### Subfamily Euderinae

#### 31. Genus *Euderus* Haliday (Fig. 45)

*Diagnosis*.—Tarsi 4-segmented. Funicle 4-segmented. Fore wing with 2–3 lines of radiating setae and with distinct row of setae ventrally in the admarginal area (Fig. 45). Notauli deep, complete.

*Notes*.—Yoshimoto (1971) provides a key to the species north of Mexico, and Noyes (1998) records 30 species from the Nearctic region with five of these known from California. These are primary parasites of Lepidoptera, Coleoptera, and Hymenoptera, or secondary parasites of Lepidoptera through Ichneumonidea. The specimen reared in this study is newly associated with *Neurobathura bohartiella* Opler, a gracillariid.

### Family EUPELMIDAE Subfamily Eupelminae

#### 32. Genus *Eupelmus* Dalman (Figs. 62–65, 68–69)

*Diagnosis*.—Tarsi 5-segmented. Funicle 7-segmented. Mesopleuron enlarged and convex (Fig. 63) (females only). Mesoscutum with large concave depression (Fig. 62); pro- and mesocoxae separated by several times their own diameter. Syntergum varied in structure, often emarginate (Fig. 68). Fore wing usually hyaline or with longitudinal infuscate band; propodeum with mesotibia lacking oblique apical groove and dark apical pegs above base of tibial

spur (Fig. 69);  $Gt_1$  and one or more of  $Gt_{2-4}$  with posterior margins broadly or narrowly V-like emarginate.

*Notes*.—Noyes (1998) reported 42 species from the Nearctic region; six were found in California. The subgenus *Eupelmus* (*Eupelmus*) is cosmopolitan, but most speciose in the Nearctic where they are parasitoids or hyperparasitoids of numerous taxa of Holometabola, usually cryptically-feeding taxa. Some are known from eggs of Homoptera, Mantodea, Coleoptera, Lepidoptera and Orthoptera (Bouček 1988, Gibson 1995). The specimens reared in this study are associated with an unknown leafminer (Gelechiidae) on *Arctostaphylos glauca* Lindl. (Ericaceae) as well as *Cameraria shenaniganensis* Opler and Davis (Gracillariidae), and *Prodoxus coloradensis* Riley (Prodoxidae).

#### 33. Genus *Brasema* Cameron (Figs. 66–67)

*Diagnosis*.—Tarsi 5-segmented. Funicle 7-segmented. Mesopleuron enlarged and convex (females only). Syntergum in dorsal view with posterior margin truncate or slightly emarginate (Fig. 66). Fore wing usually hyaline or with longitudinal infuscate band; propodeum with plical region sublunate to quadrate, but broad and in approximately same plane as callar region; mesotibia with oblique apical groove and dark apical pegs above base of tibial spur (Fig. 67);  $Gt_1$  and or more of  $Gt_{2-4}$

with posterior margins broadly or narrowly V-like emarginate (Fig. 66).

*Notes.*—Approximately 50 species of *Brasema* are known (Gibson 1995), although many of these have yet to be removed from *Eupelmus*. Only five species are currently reported for the Nearctic region (Noyes 1998) and one of these is found in California. *Brasema* is cosmopolitan, but most speciose in the Neotropics where they are parasitoids or hyperparasitoids of numerous Holometabola in cryptic habitats. Some are known from eggs of Homoptera, Mantodea and Orthoptera (Gibson 1995). The species of *Brasema* herein are newly associated with Agromyzidae (*Liriomyza* sp.).

Family EURYTOMIDAE  
Subfamily Eurytominae

34. Genus *Eurytoma* Illiger  
(Fig. 106)

*Diagnosis.*—Tarsi 5-segmented. Funicle 5-segmented. Pronotum quadrate in dorsal view (Fig. 106). Body sculpture umbilicately punctate. Propodeum usually depressed or channeled medially.

*Notes.*—Bugbee (1967) provided a key to species north of Mexico. Of the approximately 700 nominal species worldwide, at least 92 occur in the Nearctic with dozens in California (Noyes 1998). This genus exhibits a wide host range from phytophagy (at least 4 plant families) to entomophagy (Coleoptera, Diptera, Lepidoptera, Hymenoptera, Hemiptera, Araneae) or both (DiGiulio 1997). The species reared in this study emerged from an unknown leafminer on *Penstemon caesius* A. Gray (Scrophulariaceae).

Family PTEROMALIDAE  
Subfamily Miscogasterinae

35. Genus *Callimerismus* Graham

*Diagnosis.*—Tarsi 5-segmented. Funicle 6-segmented. Clypeus with three asymmetrically arranged apical denticles. Pronotum angular between collar and neck.

First gastral tergum with posterior margin nearly straight; petiole less than  $1.4\times$  as long as broad and anteroventrally braced with transverse flange (as in Fig. 74). Propodeum with submedian area strongly reticulate (as in Fig. 80). Color metallic green.

*Notes.*—Until now, no host had been recorded for this genus (Heydon 1989) and only one species was known from eastern North America and four worldwide (Noyes 1998). The species reared in this study emerged from an unknown leafminer on *Penstemon caesius* A. Gray (Scrophulariaceae).

36. Genus *Thinodytes* Graham  
(Figs. 32, 75–77)

*Diagnosis.*—Tarsi 5-segmented. Funicle 6-segmented (Fig. 32), scape usually metallic. Clypeus either with one asymmetric tooth (Fig. 75) or with three teeth (none known with bidentate clypeus), but then teeth usually sharp and with only narrow gap between them. Palps and stipites in male slender. Pronotum angular between collar and neck. First gastral tergum with posterior margin nearly straight (as in Fig. 79); petiole less than  $1.4\times$  as long as broad and anteroventrally braced with transverse flange (Fig. 77). Propodeum with submedian area strongly reticulate (Fig. 76). Color almost wholly black to metallic green. According to Heydon (1995), *Thinodytes* is characterized by its complete absence of synapomorphies defining related genera. Two genera commonly confused with *Thinodytes* are *Halticoptera* and *Maulius*. These latter genera are recognized by having the torulus above lower eye margin, the petiole without a median carina and with its anterolateral corners sharp and enlarged (*Maulius*), the scape usually non-metallic, the male maxilla with lamellately expanded palps and usually with another lobe on the stipites, the petiole usually with median carina and with anterolateral corners of petiole not so greatly expanded (*Halticoptera*).

*Notes.*—Five members of this genus are known from the Nearctic region with three of these known to occur in California (Noyes 1998). All known hosts are small Diptera living in plants as stem or leaf miners (Heydon 1995). The species reared in this study emerged from an unknown leafminer on *Penstemon caesius* A. Gray (Scrophulariaceae).

37. Genus *Halticoptera* Spinola  
(Figs. 72–74)

*Diagnosis.*—Tarsi 5-segmented. Funicle 6-segmented. Clypeus bidentate (Fig. 73). Pronotum angular between collar and neck. First gastral tergum with posterior margin usually emarginate; petiole less than 1.4× as long as broad, anteroventrally braced with transverse flange and with longitudinal carina (Fig. 74). Propodeum with submedian area strongly reticulate. Color bright metallic green.

*Notes.*—See discussion under *Thinodytes* for differentiating this genus from *Mauleus* and *Thinodytes*. Approximately nine species have been recorded from the Nearctic region and three from California (Noyes 1998). Records for *Halticoptera* presented here include one new host association with *Calcomyza* sp. (Agromyzidae).

38. Genus *Mauleus* Graham  
(Fig. 82)

*Diagnosis.*—Tarsi 5-segmented. Funicle 6-segmented. Clypeus bidentate (Fig. 82). Pronotum angular between collar and neck; dorsum of mesosoma as high as vertex. Gt1 with posterior margin usually emarginate; petiole less than 1.4× as long as broad and anteroventrally braced with transverse flange (as in Fig. 77). Propodeum with submedian area moderately reticulate (as in Fig. 76). Color dark metallic green or blue.

*Notes.*—See discussion under *Thinodytes* for differentiating this genus from *Mauleus* and *Halticoptera*. The genus *Mauleus* contains five nominal species, of which at least 3 occur in the Nearctic (Noyes 1998).

Where biologies are known, they attack leafmining Diptera (Heydon 1995). The species reared in this study emerged from an unknown leafminer on *Penstemon caesius* A. Gray.

Subfamily Pteromalinae

39. Genus *Trichomalopsis* Crawford  
(Fig. 47)

*Diagnosis.*—Tarsi 5-segmented. Funicle 6-segmented. Head lacking both postgenal carinae and depression laterad of mouth; occiput with carina halfway between ocelli and foramen. Pronotal collar not or barely margined. Propodeum with distinct plicae and often with median carina. Stigmal vein subequal in length to marginal vein.

*Notes.*—At least 15 species occur in the Nearctic (~4 from California (Noyes 1998)) region and typical hosts are pupae of Coleoptera and Lepidoptera (Bouček and Heydon 1997). The *Trichomalopsis* reared in this study are associated with ?*Periploca* sp. (Gelechiidae) and an unidentified chrysomelid.

40. Genus *Mesopolobus* Westwood  
(Figs. 44, 78–81)

*Diagnosis.*—Tarsi 5-segmented. Funicle 5- or 6-segmented. Pronotal collar typically without conspicuous smooth strip or body with the following features: mesoscutal reticulation regular, usually without distinct setiferous punctures (Fig. 79); left mandible with 3 teeth, the right with 4. Flagellum with 3rd flagellomere anelliiform, shorter than pedicel. Ocelli not very small; propodeal spiracle ovate, its longest diameter  $\frac{1}{3}$ – $\frac{1}{4}$  length of propodeum. One of the most poorly defined genera in Pteromalidae, often confused with *Pteromalus*, among others. *Pteromalus* has the third flagellomere  $\geq$  the length of the pedicel and the nucha raised reticulate, while *Mesopolobus* has the third flagellomere  $<$  the length of the pedicel and the nucha at most striate.

*Notes.*—Noyes (1998) listed over 200 named species of *Mesopolobus* (excluding synonymies, etc.) and the several dozen species in the Nearctic region attack insects in galls of Cynipidae and pupae of Lepidoptera, Symphyta, and Coleoptera (Bouček and Heydon 1997). The new association for *Mesopolobus* is *Cameraria sempervirensella* Opler and Davis (Gracillariidae).

41. Genus *Pteromalus* Swederus  
(Figs. 55–56, 70–71, 83)

*Diagnosis.*—Tarsi 5-segmented. Funicle 6-segmented. Pronotal collar with or without conspicuous smooth strip. Left mandible with 3 or 4 teeth, the right always with 4 teeth. Flagellum with 3rd flagellomere often only slightly transverse, quadrate or oblong, as long as or longer than pedicel. Stigmal vein  $\frac{2}{3}$ – $\frac{1}{5}$  length of marginal vein (Fig. 55); propodeum lacking costula and with posterior corner obtuse; pronotal collar with abrupt or round margin (Figs. 70, 83). It is difficult in many instances to differentiate between *Mesopolobus* and *Pteromalus* as both are very similar (see above), but *Pteromalus* usually has a more compact head (Fig. 56).

*Notes.*—Well over 1,000 names worldwide are listed in this genus by Noyes (1998) (excluding synonymies, etc.). At least 40 species occur north of Mexico on pupae of Lepidoptera, Coleoptera and their parasitic Hymenoptera. One species occurs in spider egg sacs (Bouček and Heydon 1997).

**Subfamily Spalangiinae**

42. Genus *Spalangia* Latrielle  
(Figs. 112–113)

*Diagnosis.*—Tarsi 5-segmented. Funicle 7-segmented, clava unsegmented. Toruli just dorsad of mouth opening (Fig. 112). Upper face with row of punctae medially. Head and mesosoma usually with deep, setiferous punctures and shiny between (Fig. 113). Petiole elongate with longitudinal carinae.

*Notes.*—Minimally 12 species in the Nearctic known to attack puparia of Diptera (Burks 1969), with at least six species on synanthropic flies. Four species are known from California (Noyes 1998). The specimen of *Spalangia* reared here is newly associated with *Liriomyza* sp. (Agromyziidae).

**Family TORYMIDAE**  
**Subfamily Toryminae**

43. Genus *Microdontomerus* Crawford  
(Fig. 46)

*Diagnosis.*—Tarsi 5-segmented. Funicle 5-segmented. Metapleuron separated by straight line from mesopleuron, not projecting forward (as in Fig. 51). Metafemur with ventral margin minutely serrate (Fig. 46). Propodeum with two complete submedian carinae.

*Notes.*—Four species (6 undescribed) species in the Nearctic region, of which three are known from California (Grissell 1979, Grissell 1995, Grissell 1997) are primary and secondary parasites of Lepidoptera, Coleoptera, Diptera, Aculeata, and their parasites (Braconidae). The specimen reared during this study is associated with *Coelopoeta glutinosi* (Walsingham), an elachistid.

44. Genus *Torymus* Dalman

*Diagnosis.*—Tarsi 5-segmented. Funicle 7-segmented. Metapleuron separated by sinuous line from mesopleuron, projecting forward into mesopleuron (Fig. 52). Metafemur lacking teeth (as in Figs. 36–37). Fore wing with marginal vein at least  $7.0\times$  as long as stigmal vein (Fig. 40).

*Notes.*—Over 320 species of *Torymus* occur worldwide and keys have been provided by Huber (1927) and Grissell (1976—part) to the approximately 99 species north of Mexico. Approximately 35 species are recorded by Noyes (1998) as occurring in California. Species of *Torymus* usually attack gall-forming Cynipidae, Cecidomyiidae or are phytophagous. The

single male specimen reared in this study is associated with an unknown leafminer on *Arctostaphylos glauca* Lindl. (Ericaceae).

#### QUESTIONABLE RECORDS

Superfamily Chalcidoidea

Family SIGNIPHORIDAE

Genus *Chartocerus* Motschulsky

Members of Signiphoridae are most frequently reared from Hemiptera, Aphididae and Psyllidae, but are also known to be hyperparasitic through Hymenoptera and Diptera. While *Chartocerus* are primarily obligate hyperparasitoids of the aforementioned taxa, they also have been recovered from puparia of Diptera (Chamaemyiidae (Woolley 1997), Drosophilidae (Hanson 1995), and Chloropidae (Erdős 1957)). A single specimen was reared from a blotch leaf mine on *Quercus* sp., which was mined by an unknown species of leafminer. Though not impossible in terms of hosts associations, we prefer to place this specimen as questionable both until a definitive host record becomes available and because this was the only signiphorid recovered in well over 15,000 rearings included in this study.

Family MYMARIDAE

Genus *Gonatocerus* Nees

The members of this genus are known to attack eggs of Cicadellidae and Membracidae (Huber 1997). Although supposedly reared from a species of *Liriomyza* mining leaves of *Datisca glomerata*, we believe that this specimen emerged from undetected contamination rather than the agromyzid.

Family PTEROMALIDAE

Genus *Lyrcus* Walker

Over 15 species are known from the Nearctic (Heydon and Bouček 1992). There is only one described species in western Canada and western United States and several undescribed species. The specimen in this study is associated with *Liriomyza* sp. on *Salvia mellifera* Greene. This species

is known from gall-forming Cecidomyiidae and *Rhopalomyia* spp. are known to form tubular leaf galls on western *Salvia* spp. These galls are often inconspicuous and may have been overlooked as a contaminant giving rise to the *Lyrcus justicia* (Girault) specimen.

#### ACKNOWLEDGMENTS

We wish to thank the Citrus Research Board (CRB) of California for providing funds to JMH for a large portion of this project. JBW would like to acknowledge the support of a NATO Postdoctoral Fellowship which funded taxonomic work with the Braconidae included here. DLW received support from NSF Grant BSR-9007671. Permission to collect on California State Park System lands was provided with the assistance of Arthur Fong. The following people provided valuable identifications: Don Davis, Jerry Powell, John Brown, John DeBenedictis, Dave Adamski (microlepidoptera), Christer Hansson (Eulophidae: Entedoninae), Mike Sharkey (Braconidae: Agathidiinae), Sonja Scheffer (Agromyzidae), Greg Zolnerowich (Encyrtidae), Roger Burks (Pteromalidae) and to both Andy Sanders of the UC Riverside herbarium and to the herbarium staff of the University of California, Berkeley (plants). Other personnel who provided technical and/or sample collection and processing assistance are: Michael Goeden, Mee Vang, Katherine Reitz, Marta Guillén, Dave Hawks, and Tami Carlow. Thanks also to Eric Grissell (USDA-SEL), Mark Shaw (Edinburgh) and John LaSalle (CSIRO) who commented on earlier versions of the manuscript and improved it considerably.

#### LITERATURE CITED

- Askew, R. 1968. Hymenoptera. 2. Chalcidoidea, Section (b). *Handbooks for the Identification of British Insects* 8(2b): 1-39.
- Askew, R. and M. Shaw. 1974. An account of the Chalcidoidea (Hymenoptera) parasitising leaf-mining insects of deciduous trees in Britain. *Biological Journal of the Linnean Society* 6: 289-335.
- Bennett, F. 1993. Do introduced parasitoids displace native ones? *Florida Entomologist* 76: 54-63.
- Bouček, Z. 1959a. A study of central European Eulophidae, I: Eulophinae (Hymenoptera). *Acta Entomologica Musei Nationalis Pragae* 33: 117-169.
- Bouček, Z. 1959b. A study of central European Eulophidae, II: *Diantlinopsis* and *Cirrospilus* (Hymenoptera). *Acta Entomologica Musei Nationalis Pragae* 33: 171-194.
- Bouček, Z. 1965. Studies of European Eulophidae, IV: *Pediobius* Walk. and two allied genera (Hymenoptera). *Acta Entomologica Musei Nationalis Pragae* 36: 5-90.

- Bouček, Z. 1988. Australasian Chalcidoidea (Hymenoptera). *A Biosystematic Revision of Genera of Fourteen Families, with Reclassification of Species*. CAB International, United Kingdom, 832 pp.
- Bouček, Z. 1992. The New World genera of Chalcididae (Hymenoptera). *Memoirs of the American Entomological Institute* 53: 49–117.
- Bouček, Z. and R. Askew. 1968. Index to Palaearctic Eulophidae (excl. Tetrastichinae). In Delucchi, V and G. Remaudiere [eds.], *Index of Entomophagous Insects* 3, pp. 9–254.
- Bouček, Z. and S. Heydon. 1997. Chapter 17. Pteromalidae, pp. 541–692. In Gibson, G., Huber, J. and J. Woolley [eds.]. *Annotated Keys to the Genera of Nearctic Chalcidoidea (Hymenoptera)*. NRC Research Press, Ottawa, Canada.
- Bryan, G. 1980. The British species of *Achrysocharoides* (Hymenoptera: Eulophidae). *Systematic Entomology* 5: 245–262.
- Bugbee, R. 1967. Revision of chalcid wasps of genus *Eurytoma* in America north of Mexico. *Proceedings of the United States Natural History Museum* 118: 433–552.
- Burks, B. 1940. Revision of the chalcid-flies of the tribe Chalcidini in America north of Mexico. *Proceedings of the United States Natural History Museum* 88: 237–354.
- Burks, B. 1960. A revision of the genus *Brachymeria* Westwood in America north of Mexico. *Transactions of the American Entomological Society* 86: 225–273.
- Burks, B. 1969. Species of *Spalangia* Latrielle in the United States National Collection (Hymenoptera: Pteromalidae). *Smithsonian Contributions to Zoology* 2: 1–7.
- Burks, B. 1971. The Nearctic species of *Horismenus* Walker (Hymenoptera: Eulophidae). *Proceedings of the Entomological Society of Washington* 73: 69–83.
- Carlson, R. 1979. Family Ichneumonidae. In Krombein, K., Hurd, P., Smith, D., and Burks, B. [eds.]. *Catalog of Hymenoptera in America North of Mexico*, volume 1, pp. 315–741. Smithsonian Institution Press, Washington, D.C.
- Delvare, G. 1992. Reclassification of the Chalcidini (Hym., Chalcididae) with a check list of the New World species. *Memoirs of the American Entomological Institute* 53: 119–157.
- DiGiulio, J. 1997. Chapter 12. Eurytomidae, pp. 477–495. In Gibson, G., Huber, J. and J. Woolley [eds.], *Annotated keys to the Genera of Nearctic Chalcidoidea (Hymenoptera)*. NRC Research Press, Ottawa, Canada.
- Doganlar, M. 1980. Two new species of *Chrysocharis* Foerster and a new synonymy and record of *Sympiesis* Foerster (Hymenoptera: Chalcidoidea: Eulophidae) from western Canada. *Türkiye Bitki Koruma Dergisi* 4: 119–129.
- Erdős, J. 1957. Recentiores observationes entomocoenologicae in *Pragmites communis* Trin. *Allatani Közlemények* 46: 60–65.
- Evans, H. 1978. The Bethyilidae of North America north of Mexico. *Memoirs of the American Entomological Institute* 27: 1–332.
- Fitton, M. G., M. R. Shaw and I. D. Gauld. 1988. Pimpline ichneumon-flies. Hymenoptera, Ichneumonidae (Pimplinae). *Handbooks for the Identification of British Insects* 7(1): 1–110.
- Gates, M. 2000. A new species of *Cirrospilus* Westwood (Hymenoptera: Eulophidae) from the southwestern United States and Mexico. *Proceedings of the Entomological Society of Washington* 102: 58–61.
- Gibson, G. 1995. Parasitic wasps of the subfamily Eupelminae: classification and revision of world genera (Hymenoptera: Chalcidoidea, Eupelminidae). *Memoirs on Entomology, International* 5: 1–421.
- Gibson, G., Huber, J. and J. Woolley [eds.]. 1997. *Annotated Keys to the Genera of Nearctic Chalcidoidea (Hymenoptera)*. NRC Research Press, Ottawa, Canada.
- Godfray, H. 1994. Parasitoids: Behavioral and Evolutionary Ecology. *Monographs in Behavior and Ecology*. Princeton University Press, 473 pp.
- Gordh, G. 1978. Taxonomic notes on *Zagrammosoma*, a key to the Nearctic species and descriptions of new species from California (Hymenoptera: Eulophidae). *Proceedings of the Entomological Society of Washington* 80: 344–359.
- Gordh, G. and R. Hendrickson. 1979. New species of *Diglyplus*; a world list of the species, taxonomic notes and a key to New World species of *Diglyplus* and *Diulinopsis* (Hymenoptera: Eulophidae). *Proceedings of the Entomological Society of Washington* 81: 666–684.
- Gordh, G. 1979. Family Encyrtidae. In Krombein, K., Hurd, P., Smith, D., and Burks, B. [eds.]. *Catalog of Hymenoptera in America North of Mexico*, volume 1, pp. 890–967. Smithsonian Institution Press, Washington, D.C.
- Goulet, H. and J. Huber [eds.]. 1995. *Hymenoptera of the World: An Identification Guide to Families*. Agriculture Canada, 668 pp.
- Graham, M. W. R. de V. 1987. A reclassification of European Tetrastichinae (Hymenoptera: Eulophidae), with a revision of certain genera. *Bulletin of the British Museum (Natural History) Entomology Series* 55: 1–392.
- Graham, M. W. R. de V. 1991. Reclassification of European Tetrastichinae (Hymenoptera: Eulophidae): revision of the remaining genera. *Memoirs of the American Entomological Institute* 49: 1–322.
- Grissell, E. 1976. Revision of Western Nearctic Species of *Torymus* Dalman (Hymenoptera: Torymidae).

- University of California Publication in Entomology 79: 1–120.
- Grissell, E. 1979. Family Torymidae. In Krombein, K., Hurd, P., Smith, D., and Burks, B. [eds.]. *Catalog of Hymenoptera in America North of Mexico*, volume 1, pp. 748–768. Smithsonian Institution Press, Washington, D.C.
- Grissell, E. 1995. Toryminae (Hymenoptera: Chalcidoidea: Torymidae): A Redefinition, Generic Classification, and Annotated World Catalog of Species. *Memoirs on Entomology, International* 2: 1–470.
- Grissell, E. 1997. Chapter 21. Torymidae, pp. 709–725. In Gibson, G., Huber, J. and J. Woolley [eds.], *Annotated Keys to the Genera of Nearctic Chalcidoidea (Hymenoptera)*. NRC Research Press, Ottawa, Canada.
- Guillén, M., D. Davis, and J. Heraty. 2001. Systematics and biology of a new, polyphagous species of *Marmara* (Lepidoptera: Gracillariidae) infesting grapefruit in the southwestern United States. *Proceedings of the Entomological Society of Washington* 103: 636–654.
- Hagley, E. 1985. Parasites recovered from the overwintering generation of the spotted tentiform leafminer, *Phyllonorycter blancardella* (Lepidoptera: Gracillariidae) in pest-management apple orchards in southern Ontario. *Canadian Entomologist* 117: 371–374.
- Hanson, P. 1995. Chapter 11.15. Signiphoridae, pp. 369–372. In Hanson, P. and I. Gauld [eds.], *Hymenoptera of Costa Rica*. Oxford University Press, 893 pp.
- Hansson, C. 1985a. Taxonomy and biology of Palaearctic species of *Chrysocharis* Förster, 1856 (Hymenoptera: Eulophidae). *Entomologica Scandinavica, Supplement* 26: 1–130.
- Hansson, C. 1985b. The entedonine genera *Achrysocharoides* Girault, *Chrysocharis* Förster and *Kratoyisma* Bouček (Hymenoptera: Eulophidae) in the Oriental region. *Entomologica Scandinavica* 16: 217–226.
- Hansson, C. 1987. Revision of the New World species of *Chrysocharis* Förster, 1856 (Hymenoptera: Eulophidae). *Entomologica Scandinavica, Supplement* 31: 1–87.
- Hansson, C. 1994. Re-evaluation of the genus *Closterocerus* Westwood (Hymenoptera: Eulophidae), with a revision of the Nearctic species. *Entomologica Scandinavica* 25: 1–25.
- Hansson, C. 1995. Revision of the Nearctic species of *Neochrysocharis* Kurdjumov (Hymenoptera: Eulophidae). *Entomologica Scandinavica* 26: 27–46.
- Heppner, J. 1993. Citrus leafminer, *Phyllocnistis citrella*, in Florida (Lepidoptera: Gracillariidae: Phyllocnistinae). *Tropical Lepidoptera* 4: 49–64.
- Heraty, J. and D. Hawks. 1998. Hexamethylsilozane—a chemical alternative for drying insects. *Entomological News* 109: 369–374.
- Heydon, S. 1989. Review of Nearctic *Ricinocoelia* and *Callimerismus* with discussion of their phylogenetic relationships (Hymenoptera: Pteromalidae). *Journal of the New York Entomological Society* 97: 347–357.
- Heydon, S. 1995. A review of the North American species of *Thinodytes* Graham and *Mauleus* Graham (Hymenoptera: Pteromalidae). *Journal of Hymenoptera Research* 4: 1–24.
- Heydon, S. and Z. Bouček. 1992. Taxonomic changes in Nearctic Pteromalidae, with the description of some new taxa (Hymenoptera: Chalcidoidea). *Proceedings of the Entomological Society of Washington* 94: 471–489.
- Huber, L. 1927. A taxonomic and ecological review of the North American chalcid-flies of the genus *Callimome*. *Proceedings of the United States National Museum* 70: 1–114.
- Huber, J. 1997. Chapter 14. Mymaridae, pp. 499–530. In Gibson, G., Huber, J. and J. Woolley [eds.], *Annotated Keys to the Genera of Nearctic Chalcidoidea (Hymenoptera)*. NRC Research Press, Ottawa, Canada.
- Johnson, E., Laing, J. and R. Trottier. 1976. The seasonal occurrence of *Lithocolletis blancardella* (Gracillariidae), and its major natural enemies in Ontario apple orchards. *Proceedings of the Entomological Society of Ontario* 107: 31–45.
- Kamijo, K. 1990. Descriptions of five new species of *Achrysocharoides* from Japan, with notes on species groups. *Akitsu* 119: 1–15.
- Kamijo, K. 1991. Revision of North American *Achrysocharoides* (Hymenoptera: Eulophidae). *Akitsu* 124: 1–34.
- Kazmi, S. and M. Hayat. 1998. Revision of the Indian Copidosomatini (Hymenoptera: Chalcidoidea: Encyrtidae). *Oriental Insects* 32: 287–362.
- Kerrich, G. 1973. A revision of the tropical and subtropical species of the eulophid genus *Pediobius* Walker (Hymenoptera: Chalcidoidea). *Bulletin of the British Museum (Natural History) Entomology* 29: 115–199.
- Knapp, J., L. Abrigo, H. Browning, R. Bullock, J. Heppner, D. Hall, M. Hoy, A. Nguyen, J. Peña, and P. Stansly. 1995. Citrus leafminer, *Phyllocnistis citrella* Stainton: current status in Florida—1995. University of Florida Cooperative Extension Service, 35 pp.
- Krombein, K., Hurd, P., Smith, D., and Burks, B. [eds.]. 1979. *Catalog of Hymenoptera in America North of Mexico*, volume 1, 1198 pp. Smithsonian Institution Press, Washington, D.C.
- Landry, J.-F. and B. Landry. 1994. A technique for setting and mounting Microlepidoptera. *Journal of the Lepidopterist Society* 48: 205–227.
- LaSalle, J. 1989. Notes on the genus *Zagrammosoma*

- (Hymenoptera: Eulophidae) with description of new species. *Proceedings of the Entomological Society of Washington* 91: 230–236.
- LaSalle, J. 1993. Parasitic Hymenoptera, biological control, and biodiversity. In LaSalle, J. and I. Gauld [eds.], *Hymenoptera and Biodiversity*. CABI, Wallingford, United Kingdom, pp. 197–215.
- LaSalle, J. 1994. North American genera of Tetrastichinae (Hymenoptera: Eulophidae). *Journal of Natural History* 28: 109–236.
- LaSalle, J. and I. Gauld. 1993. Parasitic Hymenoptera: their diversity and their impact on the diversity of other organisms. In LaSalle, J. and I. Gauld [eds.], *Hymenoptera and Biodiversity*. CABI, Wallingford, United Kingdom, pp. 1–26.
- LaSalle, J. and M. Parrella. 1991. The chalcidoid parasites (Hymenoptera: Chalcidoidea) of economically important leaf-mining *Liriomyza* species (Diptera: Agromyzidae) in North America. *Proceedings of the Entomological Society of Washington* 93: 571–591.
- LaSalle, J. and J. Peña. 1997. A new species of *Galeosomyia* (Hymenoptera: Eulophidae): a fortuitous parasitoid of the citrus leafminer, *Phyllocnistis citrella* (Lepidoptera: Gracillariidae). *Florida Entomologist* 80: 461–470.
- Legaspi, J. and J. French. 1996. The citrus leafminer and its natural enemies. *Texas A and M University Circular* B96-1.
- Maier, C. 1984a. Seasonal development and flight activity of the spotted tentiform leafminer, *Phyllonorycter blancardella* (Lepidoptera: Gracillariidae), in Connecticut. *Canadian Entomologist* 116: 435–441.
- Maier, C. 1984b. Abundance and phenology of the parasitoids of the spotted tentiform leafminer, *Phyllonorycter blancardella* (Lepidoptera: Gracillariidae), in Connecticut. *Canadian Entomologist* 116: 443–449.
- Maier, C. 1988a. Parasitoid fauna of two *Phyllonorycter* spp. (Lepidoptera: Gracillariidae) on wild cherries, and similarity to fauna of apple leafminers. *Annals of the Entomological Society of America* 81: 460–466.
- Maier, C. 1988b. Gracillariid hosts of *Sympiesis marylandensis* (Hymenoptera: Eulophidae) in New England. *Annals of the Entomological Society of America* 81: 728–732.
- Massa, B., M. Rizzo, and V. Caleca. 2001. Natural alternative hosts of Eulophidae (Hymenoptera: Chalcidoidea) parasitoids of the citrus leafminer *Phyllocnistis citrella* Stainton (Lepidoptera: Gracillariidae) in the Mediterranean basin. *Journal of Hymenoptera Research* 10: 91–100.
- Miller, C. 1965. A Nearctic species of *Parablastothrix* Mercet (Hymenoptera: Encyrtidae). *Canadian Entomologist* 97: 750–753.
- Miller, C. 1970. The Nearctic species of *Pnigalio* and *Sympiesis* (Hymenoptera: Eulophidae). *Memoirs of the Entomological Society of Canada* 68: 1–121.
- Noyes, J. 1998. *Catalogue of the Chalcidoidea of the World*. CD-ROM. Expert Center for Taxonomic Information, Amsterdam, The Netherlands.
- Noyes, J., J. Woolley, and G. Zolnerowich. 1997. Chapter 8. Encyrtidae, pp. 170–320. In Gibson, G., Huber, J. and J. Woolley [eds.], *Annotated keys to the Genera of Nearctic Chalcidoidea (Hymenoptera)*. NRC Research Press, Ottawa, Canada.
- Peck, O. 1985. The taxonomy of the Nearctic species of *Pediobius* (Hymenoptera: Eulophidae), especially Canadian and Alaskan forms. *Canadian Entomologist* 117: 647–704.
- Peña, J., R. Duncan, and H. Browning. 1996. Seasonal abundance of *Phyllocnistis citrella* (Lepidoptera: Gracillariidae) and its parasitoids in south Florida citrus. *Environmental Entomology* 25: 698–702.
- Pottinger, R. and E. LeRoux. 1971. The biology and dynamics of *Lithocolletis blancardella* (Lepidoptera: Gracillariidae) on apple in Quebec. *Memoirs of the Entomological Society of Canada* 77: 1–437.
- Ridgway, N. and D. Mahr. 1985. Natural enemies of the spotted tentiform leafminer, *Phyllonorycter blancardella* (Lepidoptera: Gracillariidae), in sprayed and unsprayed apple orchards in Wisconsin. *Environmental Entomology* 14: 459–463.
- Rose, M. and P. DeBach. 1982. A native parasitoid of the barberry whitefly. *Citrograph* 67: 272–276.
- Rose, M. and P. DeBach. 1992. Biological control of *Parabemisia myricae* (Kuwana) (Homoptera: Aleyrodidae) in California. *Israel Journal of Entomology* 26: 73–95.
- Schauff, M. 1985. Taxonomic study of the Nearctic species of *Elachertus* Spinola (Hymenoptera: Eulophidae). *Proceedings of the Entomological Society of Washington* 87: 843–858.
- Schauff, M. and J. LaSalle. 1993. Nomenclatural notes on genera of North American Eulophidae (Hymenoptera: Chalcidoidea). *Proceedings of the Entomological Society of Washington* 95: 488–503.
- Schauff, M., J. LaSalle, and L. Coote. 1997. Chapter 10. Eulophidae, pp. 327–429. In Gibson, G., Huber, J. and J. Woolley [eds.], *Annotated Keys to the Genera of Nearctic Chalcidoidea (Hymenoptera)*. NRC Research Press, Ottawa, Canada.
- Schauff, M., J. LaSalle, and G. Wijesekara. 1998. The genera of chalcid parasitoids (Hymenoptera: Chalcidoidea) of citrus leafminer *Phyllocnistis citrella* Stainton (Lepidoptera: Gracillariidae). *Journal of Natural History* 32: 1001–1056.
- Shaw, M. and R. Askew. 1976. Ichneumonoida (Hymenoptera) parasitic upon leaf-mining insects of the order Lepidoptera, Hymenoptera and Coleoptera. *Ecological Entomology* 1: 127–133.
- Storozheva, N. 1982. A key to Palearctic species of parasitic wasps in the genus *Sympiesis* Förster,

- 1856 (Hymenoptera: Eulophidae). *Entomologicheskoe Obozrenie* 61: 164–176.
- Townes, H. 1970a. Genera of Ichneumonidae, part 2. *Memoirs of the American Entomological Institute* 12: 1–537.
- Townes, H. 1970b. Genera of Ichneumonidae, part 3. *Memoirs of the American Entomological Institute* 13: 1–307.
- Townes, H. 1983. Revision of twenty genera of Gelini (Ichneumonidae). *Memoirs of the American Entomological Institute* 35: 1–281.
- Townes, H. and M. Townes. 1960. Ichneumon-flies of America north of Mexico: 2. Subfamilies Ephialtinae, Xoridinae, Acaenitinae. *United States National Museum Bulletin* 216(2): 1–676.
- Viggiani, C. 1994. Recent cases of interspecific competition between parasitoids of the family Aphelinidae (Hymenoptera: Chalcidoidea). *Norwegian Journal of Agricultural Sciences. Supplement* 16: 353–359.
- Wahl, D.B. 1993. Cladistics of the genera of Mesochorinae (Hymenoptera: Ichneumonidae). *Systematic Entomology* 18: 371–387.
- Wahl, D.B. and W.R.M. Mason. 1995. The family-group names of the Ichneumoninae (Hymenoptera: Ichneumonidae). *Journal of Hymenoptera Research* 4: 285–293.
- Whitfield, J. and D. Wagner. 1988. Patterns in host ranges within the Nearctic species of the parasitoid genus *Pholtesor* Mason (Hymenoptera: Braconidae). *Environmental Entomology* 17: 608–615.
- Whitfield, J. and D. Wagner. 1991. Annotated key to the genera of Braconidae (Hymenoptera) attacking leafmining Lepidoptera in the Holarctic region. *Journal of Natural History* 25: 733–754.
- Winston, P. and D. Bates. 1960. Saturated solution for the control of humidity in biological research. *Ecology* 41: 232–237.
- Woolley, J. 1997. Chapter 18. Signiphoridae, pp. 693–699. In Gibson, G., Huber, J. and J. Woolley [eds.]. *Annotated Keys to the Genera of Nearctic Chalcidoidea (Hymenoptera)*. NRC Research Press, Ottawa, Canada.
- Yefremova, Z. 1995. Notes on some Palaearctic and Afrotropical species of the genus *Zagrammosoma* (Hymenoptera: Eulophidae). *Zoologicheskii Zhurnal* 74: 46–54.
- Yoshimoto, C. 1971. Revision of the genus *Euderus* of America north of Mexico (Hymenoptera: Eulophidae). *Canadian Entomologist* 103: 541–578.
- Yoshimoto, C. 1977. The North American species of the genus *Achrysocharoides* (Hymenoptera: Eulophidae). *Canadian Entomologist* 109: 907–930.
- Yoshimoto, C. 1983. Review of North American *Phygadeuon* Schrank (Hymenoptera: Eulophidae). *Canadian Entomologist* 115: 971–1000.
- Yu, D. S. 1998. *Taxapad 1998: Interactive Catalogue of World Ichneumonidae 1998*. Published by the author, Vancouver, British Columbia.

## A new *Leucospis* Fabricius (Hymenoptera: Leucospidae), the First Reported Gregarious Species

E. E. GRISELL AND SYDNEY A. CAMERON

(EEG) USDA, ARS, PSI, Systematic Entomology Laboratory, c/o National Museum of Natural History, Washington, DC 20560-0168, USA, email: egrissel@sel.barc.usda.gov; (SAC) Department of Entomology, 320 Morrill Hall, 505 S. Goodwin Avenue, University of Illinois, Urbana, IL 61801, USA, email: scameron@life.uiuc.edu

---

*Abstract.*—*Leucospis pinna* Grissell and Cameron, new species, is described from Ecuador. It is a parasitoid of the orchid bee *Eulaema meriana* (Olivier) (Hymenoptera: Apidae) and is the first species of *Leucospis* reported to parasitize bees in the tribe Euglossini. It is the first known member of the family reported to have gregarious larvae.

---

The genus *Leucospis* Fabricius was revised at the world level in 1974 when 109 species were recognized (Bouček 1974a). Since then five new species have been described and one name has been synonymized (Bouček 1974b, Habu 1977, Bouček and Narendran 1981, Naumann 1981, Engel 2002). Of the described species, 44 are from the New World with the great majority being Neotropical (Bouček 1974a, b). Although the entire family of Leucospidae (about 130 species) is thought to be parasitic upon aculeate Hymenoptera—solitary bees and less frequently solitary wasps—hosts are actually known only for about 30 species, and for most of these the biology remains essentially undocumented (Bouček 1974a, Noyes 2001).

Bouček (1974a) reviewed biological reports on leucospids, but most literature amounted to observations about oviposition and egg and larval morphology. Only three species are relatively well known biologically: *L. gigas* F. (Palearctic), *L. affinis* Say (Nearctic), and *L. japonica* Walker (Palearctic). Information for *L. gigas* is largely based on original work done by Fábry (1855) and subsequently summarized by workers such as Clausen (1940), Malyshev (1968), Bouček (1974a), and Hanson

(1995). In this species, several eggs were laid on each host and the active first instar larva “searches out and destroys any competitors that may be present in the same cell” (Hanson 1995). Graenicher (1906) reported on *L. affinis*, stating that it was a solitary external parasitoid with an active first instar larva that sought out the bee host within its cell (or cocoon). He could not confirm active cannibalism but stated that both rival egg and larval destruction was likely, based on his observations of the incessant movement of the single larva he found in each of three cells. *Leucospis japonica* (data summarized by Habu 1962) follows the same pattern, with the first instar larva moving about by bristles on the abdominal segments and killing off any other leucospid larva present on the host. Other than observations on these three species, relatively little is known about the life history of Leucospidae.

In this paper we describe a new *Leucospis* species attacking the large orchid bee *Eulaema meriana* (Olivier) (Hymenoptera: Apidae), the biology of which will be discussed in another paper (Cameron and Ramírez 2001). Our report is the first account of a *Leucospis* parasitizing bees in the tribe Euglossini (Apidae), although



Figs. 1-2. *Leucospis pinna*, habitus. 1, Female. 2, Male.

three species of the related genus *Polistimorpha* Westwood are known to attack bees in the genus *Euglossa* Lepeletier (Bouček 1974a). More significantly, this new species represents the first report of a gregarious ectoparasitoid species (i.e., multiple individuals emerging from the same brood cell) in the genus *Leucospis*.

*Leucospis pinna* Grissell and Cameron,  
new species  
(Figs. 1-9, 12-17)

*Holotype female* (Fig. 1).—Length 8.3 mm. Black to reddish brown with weak metallic tinge except yellow as follows: venter of flagellum, scape entirely, pronotum with narrow transverse band along apical and posterior margins, apical band extending to anterolateral corner and forming ovoid spot, midlobe of scutum with narrow band on lateral and posterior margins, posterior half of acropleuron, apex of metacoxa, apex of pro- and mesofemora, dorsal and ventral band on metafemur (Fig. 8, indicated by dotted lines), dorsum of all tibiae, pro- and mesotarsi, metatarsus ventrally (shading to brown dorsally), ovipositor sheath. Brown to reddish brown are: dorsum of flagellum, tegula, wing veins, upper third of wing, and trochanters. *Head*: Distinctly narrower than pronotum, dorsally about 3.5× wider than long, in facial view about as high as

wide (Fig. 3); occipital carina sharp, elevated, visible from front of head (Fig. 3); postocellar length (POL) 2.0× ocellocular length (OOL); ocellar area about 2.8× as broad as long; scrobal depression transversely lightly striate, carinate dorsally and basolaterally but not mediolaterally (Fig. 3); eye distinctly emarginate along inner margin. Frontovortex punctate, changing to reticulate rugose at eye emargination to lower margin of face; interantennal area with slight median keel extending partially to clypeus. Clypeus (Fig. 4) slightly broader than high, apical margin produced, slightly bilobed, without median tooth, margin carinate, slightly depressed along carina, laterally carinate at some angles of view (not apparent at some angles), apicomedian area punctate with carinae radiating dorsally to slightly above midpoint, area above with well-defined setose punctures about own diameter apart. Antenna as in Fig. 6, scape about 3× as long as broad, ventrally flat, polished (Fig. 7), otherwise covered with nearly contiguous setose punctures. Mandible (Fig. 4) with deeply semicircular broad gap separating sharp lower tooth. Eye and face (except scrobal depression) covered with short, silvery setae. *Mesosoma*: Except as noted, covered with nearly contiguous setose punctures separated by interstices less than 0.2 to 0.5 puncture

diameter, interspaces finely aciculate; dorsellum and propodeum more densely punctate and pubescent than scutum; lateral pronotum rugulose; femoral depression deep, polished to aciculate. Pronotum without transverse carinae. Mesoscutum without vestiges of parapsidal line or notaulus. Tegula punctate with edges barely aciculate. Scutellum about  $1.8\times$  wider than long. Dorsellum distinctly transverse, rectangular,  $4\times$  wider than long; lateral panel of metanotum obscured by long, silvery pubescence. Propodeum medially  $3\times$  as long as dorsellum, median carina raised into fin-like lamella, dorsally curved and posteriorly concave (Fig. 5); plica extremely well-developed, raised distinctly above surface of propodeum; spiracle, postspiracular sulcus, and callus obscured by long, dense golden pubescence; posterolateral corner angled with deep carinate concavity between it and metapleuron. Pro- and mesocoxae transversely carinate on outer surface; metacoxa (Fig. 8) in lateral (flat) view with depression evenly punctate, punctures several times own diameter apart and interstices appear polished (Fig. 8a), in oblique view punctures appear longitudinally elongate, separated by minute parallel striae (Fig. 8b), and surface appears covered with minute carinae or striae; ventral surface with minute punctures separated by polished interstices less than puncture diameter apart; punctures on entire coxa each with minute setae (less than puncture diameter in length). Metafemur (Fig. 8) about  $2\times$  as long as broad, basal tooth in middle followed by 6 or 7 smaller, irregular-sized teeth; punctation nearly touching, dense and evenly spaced over entire surface (Fig. 8c), each with minute seta. Apex of metatibia (Fig. 9) with outer spur distinctly articulated basally, curved, pointed, and about  $0.8\times$  width of tibial apex; inner spur apically blunt but with tuft of setae making spur appear pointed, in side (Fig. 9, inset) view spur flattened, curving distally, and about  $0.8\times$  width of tibial apex.

Metabasitarsus (Fig. 8) dorsally about  $1.5\times$  apical breadth of tibia. Forewing with ratio of submarginal:marginal:stigmatal:postmarginal about 11:3:2:8, patterned brown as in Fig. 12. *Metasoma*: In dorsal view, apical terga (2–5) parallel sided (Fig. 13), metasomal terga 6 (apparent 4) bulging; in side view (Fig. 14) metasomal tergum 6 greatly convex dorsally, slightly angled near apex above ovipositor sheaths; metastomal tergum 1 (petiole) not apparent; metasomal tergum 2 (first apparent) with anterolateral corners angled sharply, anterior margin polished, posterior margin with narrow polished band, otherwise densely punctate, each puncture with recumbent, backward projecting seta about  $2\times$  length of puncture diameter; apical punctures medially somewhat crenulate to longitudinally elongate, nearly touching, becoming round laterally and posteriorly, separated at least by own diameter, interspaces polished; metasomal tergum 3 not visible from above; metasomal tergum 4 visible as narrow band with slight transverse striae, without punctures; metasomal tergum 5 with complete median split, covered with contiguous dense punctation obscured by elongate golden or silvery setae each 5 or more times puncture diameter; metasomal tergum 6 with slight median split from apex about one-third distance to posterior margin, entirely covered with nearly contiguous dense punctures less than own diameter apart, interspaces slightly striate, each puncture with appressed silvery seta, setae increasing in length from dorsal surface (about 2 or 3 puncture diameters in length) posteriorly (near ovipositor sheaths) to about same length as on metasomal tergum 5; metasomal tergum 7 and 8 (syntergum) similar to dorsum of 6, 7 dorsally split; ovipositor sheath straight, exerted scarcely greater than length of inner metatibial spur; hypopygium apically pointed, reaching nearly to posterior of metasomal tergum 6.

*Male paratypes* (Fig. 2).—All about 7 mm

in length. Similar to female except as follows: Scape reddish brown, ventrally with irregular punctures similar to, but less dense than, those on sides and dorsum. In dorsal view metasoma bulging laterally (Fig. 16), in side view dorsal margin convex (Fig. 15); metasomal tergum 3 not apparent from above (possibly seen as small laterotergite at side, Fig. 15), terga 4–7 fused dorsally, with 4 (apparent 2) separated from 5 by row of distinct pits, terga 8 and 9 distinct; metasomal terga 2 and 4 with distinct laterotergites (Fig. 15), tergum 5 with indistinct laterotergite (fused along top margin but slightly indicated at anterodorsal corner, Fig. 15), punctuation on metasomal tergum 2 about as on scutellum, remainder of terga sculptured about as for female; setae similar overall but slightly longer on posterior of terga 4–7; metasomal sterna rigid, wide (Fig. 17), punctures largest on apparent sternum 1 decreasing in size to sternum 6, which is medially impunctate, sternum 7 impunctate; sternum 1 with median hook-like projection (best seen in profile, Fig. 15), apex of sterna 1 and 2 medially angled, surface of sterna 6 and 7 slightly to moderately medially concave.

*Variation.*—Females range in length from about 7 to 9 mm. The type series is consistent in most features. In some females, metasomal tergum 4 is scarcely visible as a narrow strip, whereas on others it is wide enough to see weak punctures and setae. The few males we have seen do not appear to vary even in length.

*Type material.*—Holotype female: Ecuador, Orellana, Tiputini Biodiversity Sta., 3–13-VII-2000, S. Cameron, emerged from cells in nest of *Eulaema meriana* "lizard nest" (National Museum Natural History, Washington, DC [USNM]); 39 female, 11 male paratypes same data as holotype (in Illinois Natural History Survey, University of Illinois and USNM).

*Host.*—Cells of *Eulaema meriana* (nest deposited at the Illinois Natural History Survey, University of Illinois).

*Distribution.*—Known only from the type locality in Ecuador. It is the fifth species reported from this country (Bouček 1974a, b, Noyes 2001).

*Etymology.*—The species name is derived from the latin *pinna* meaning "fin," in reference to the distinctive finlike propodeal projection.

*Discussion.*—This species would be placed in the *cayennensis* species-group as defined by Bouček (1974a), with the exception of one character, the ovipositor sheath length. Within New World *Leucospis*, the *cayennensis* species-group is unique in having the lower tooth of the mandible separated from the upper edge by a broad semicircular gap (Fig. 4). This group, composed of 8 species, is also defined by the following: the body has a slight metallic tinge, the pronotum is without a premarginal cross-carina, the propodeum is densely pilose, the sterna in males are broad and sculptured, and all species have a Central to South American distribution. In all respects, *Leucospis pinna* fits these criteria. It disagrees from other members of the group only in having extremely short ovipositor sheaths (Fig. 14), which Bouček (1974a) used, in part, to define the *texana* species group. This latter group has a stout metafemur with 4–5 long ventral teeth and a small basal tooth. All remaining New World *Leucospis*, including the *cayennensis* species group, have the metafemur with a broad basal tooth followed by 7 or more small teeth (Fig. 8).

Although Bouček's key to world leucospid species (1974a; supplemented by a modified key in 1974b) is a comprehensive monograph, the discovery of a new species that somewhat alters or modifies a species-group concept suggests that additional such cases are probable. It is likely that species groups may even change composition and definition depending on new species certainly awaiting discovery. For this reason, and because of the autapomorphy discussed below, we outline the

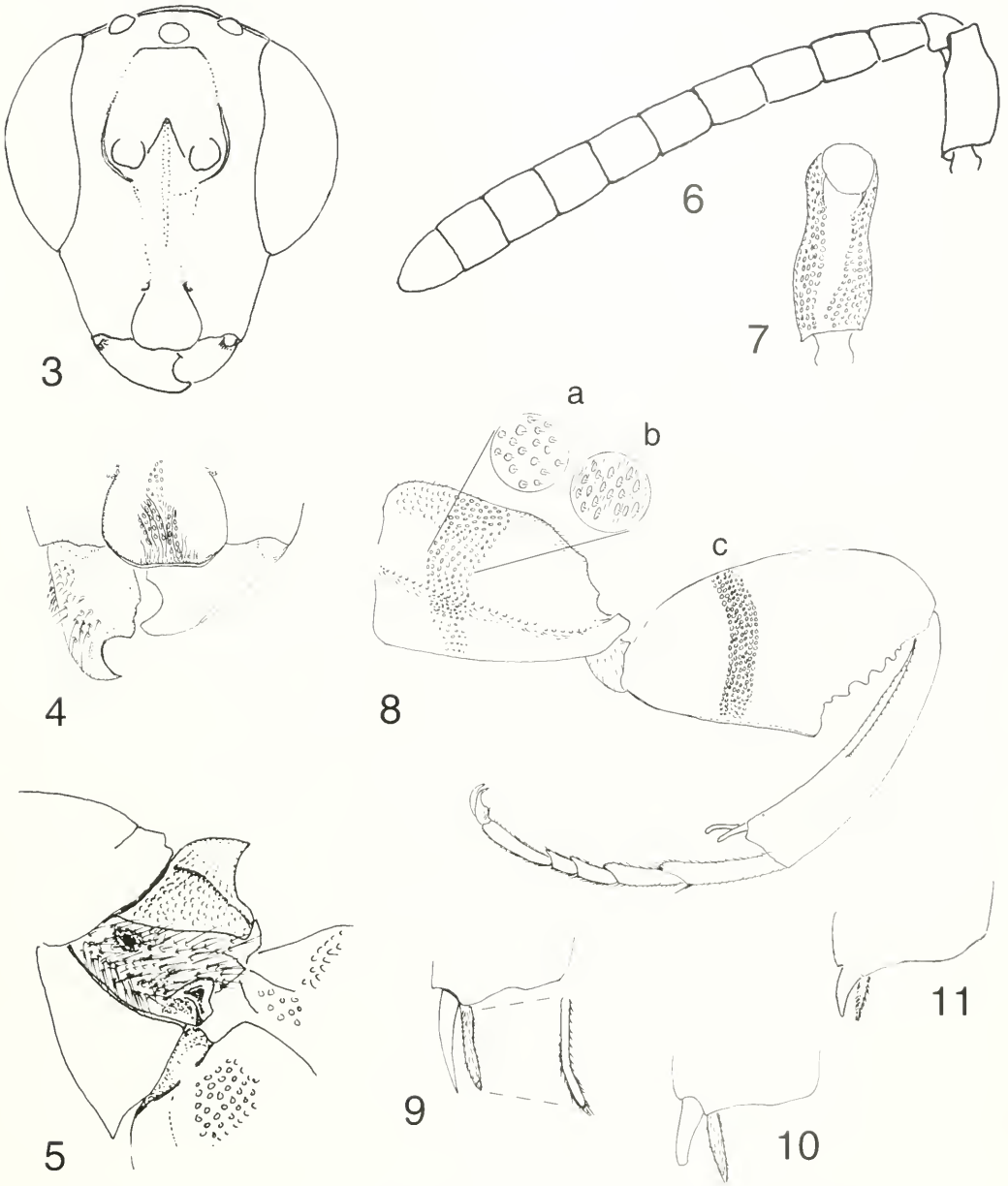

Figs. 3–11. *Leucospis* species, females. 3–8. *Leucospis pinna*. 3, Head. 4, Lower face, clypeus, and mandibles. 5, Propodeum, side view (with partial aspects of scutellum, metanotum, metapleuron, metacoxa, and apical metasoma). 6, Antenna, lateral. 7, Scape, ventral. 8, Metaleg, insets show example of sculpture on coxa and metafemur: a = punctures in lateral view; b = punctures viewed at oblique angle; c = punctures in lateral view; dotted lines on femur denote color pattern. 9–11. Metatibia, apex, outer view. 9, *Leucospis pinna*, inset showing inner spur in side view. 10, *L. cayennensis*. 11, *L. ignota*.

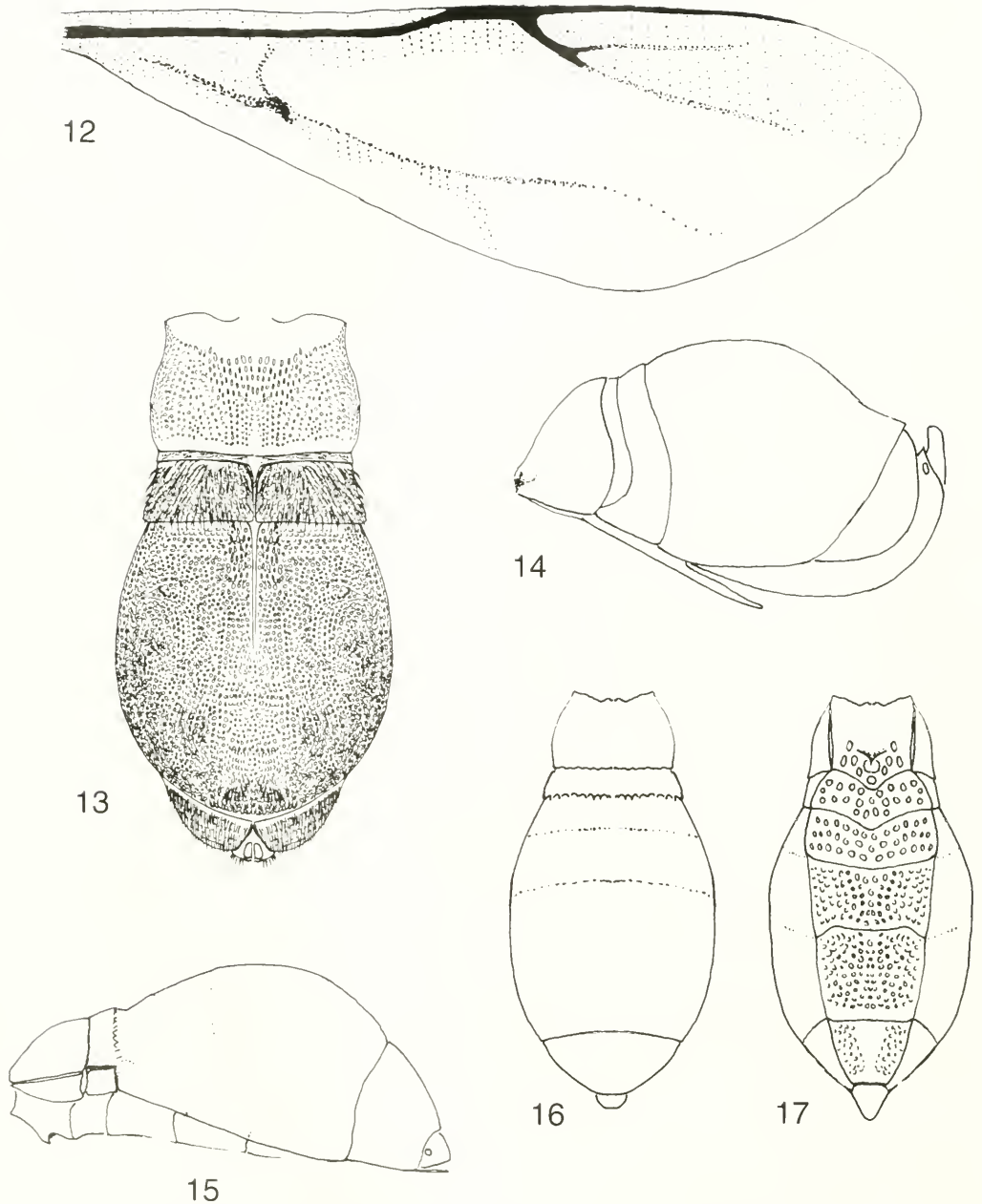

Figs. 12–17. *Leucospis pinna*. 12–14. Female. 12, Wing, dorsal view, stipling denotes color pattern. 13, Metasoma, dorsal view. 14, Metasoma, lateral view. 15–17. Male, metasoma. 15, Lateral view. 16, Dorsal view. 17, Ventral view.

major differences and distinctions of *Leucospis pinna* relative to Bouček's key and other species of the genus.

*Leucospis pinna* does not precisely fit any of the couplets in Bouček (1974) and splits

the first couplet by having the ovipositor sheaths as described for the *texana* species-group (i.e., barely exerted) but the metafemur as described for all the remaining species of *Leucospis*. Ignoring the oviposi-

tor, *Leucospis pinna* then keys directly to the *cayennensis* species-group by virtue of all the characters mentioned above. Within the group, *L. pinna* will key positively only through the first species-group couplet (Bouček 1974a, couplet 6) separating it from *L. cayennensis* Westwood and *L. mexicana* Walker on the basis of the depression of the metacoxa being punctate (polished and smooth in the latter two species). *Leucospis pinna* splits couplet 7 by having a combination of characters. It differs from *L. metatibialis* Bouček in having a heavily setose dorsellum (as in *L. metatibialis*), but it is convex not flat, as in *L. metatibialis*. It differs also in having the metatibia densely punctured (sparsely so in *L. metatibialis*), and the short ovipositor (reaching metasomal tergum 2 in *L. metatibialis*). In couplet 8a (Bouček 1974b) *L. pinna* differs from *L. genalis* Bouček and *L. leptomera* Bouček in the broad metafemur (narrow in *L. genalis* and *L. leptomera*) and in having metasomal tergum 2, in dorsal view, narrower in width than the remainder of the metasoma (subequal in width in *L. genalis* and *L. leptomera*) but agrees in the malar space greater than two-thirds the length of the scape (one-half or less in other species of the *cayennensis* species-group). If *Leucospis pinna* is taken further in the key, it would stop at couplet 9 based on the densely setose and finely punctate propodeum, which it shares with *L. ignota* Walker. It differs from this latter species, however, in the convex dorsellum (flattened and lamellate in *L. ignota*) as well as the barely exerted ovipositor (reaching nearly one-third distance to propodeum in *L. ignota*).

*Leucospis pinna* is well-defined based upon an autapomorphy of the propodeum, namely an expansion of the median carina into an asymmetric, thin, hook-like lamella (Fig. 5). No other member of the *cayennensis* species-group (and apparently no other described species) has such a pronounced median propodeal carina. In a few New World members of the *speifera*

species-group the propodeum has a median, slightly raised keel, which takes the form of a thickened, gradual arch the length of the propodeum.

Another character that aids in the recognition of this species is the structure of the metatibial spurs. In *L. pinna* they are elongate (nearly 0.8× length of tibial apex), with the outer spur distinctly articulated basally, curved, and sharply pointed apically, and the inner spur somewhat flattened, and curved with a tuft of setae at the apex (Fig. 9). Within the *cayennensis* species-group, species have the spurs relatively short and stout (Figs. 10, 11; less than 0.5× tibial apex). The apex of the outer spur may be bluntly chisel-shaped (Fig. 10) or sharp (Fig. 11), and in some cases they may appear to have no basal articulation (Fig. 11).

*Biology.*—*Leucospis pinna* is the ninth species known for the *cayennensis* species-group, within which only *L. cayennensis* has had positive biological associations. These associations have all been exclusively with the genus *Centris* (Hymenoptera: Apinae), including *C. tarsata* Smith (Fritz and Genise 1980, Chandler et al. 1985), *C. bicornuta* Mocsáry, *C. nitida* F. Smith, *C. analis* F., and *C. vittata* Lepeletier (Cooperband et al. 1999, Vieira de Jesus and Garofalo 2000). Bouček (1974a) stated that *L. ignota* (Walker) was collected at adobe walls "presumably at the nesting sites of host bees." Other than these sketchy reports, little is known about the biology of other members of the *cayennensis* species-group.

*Leucospis pinna* was collected from a single nest of *E. meriana*. As described by Cameron and Ramírez (in press), a total of 51 individuals emerged from only 2 cells (28 from one cell, 23 from another). Thus, there is no doubt about the gregarious nature of this species. The sex ratio was highly female-skewed within each cell, with only 6 males emerging from the first cell and 5 from the second, respectively. Further study is required to determine

whether gregarious adult emergence is a derived state or the ancestral condition within Leucospidae.

*Mimicry*.—*Leucospis pinna* resembles *L. egaia* Walker and *L. latifrons* Schletterer at least superficially in both color and size. Both of these are said to mimic *Polybia occidentalis* (Olivier) (Hanson 1995) as might *L. pinna* (Chris Starr, pers. comm.). As has been pointed out by Bouček (1974a), *Leucospis* species appear to mimic taxa having no apparent relationship to the hosts upon which they oviposit.

### ACKNOWLEDGMENTS

We thank Prof. Ayres Menezes (Universidade Estadual de Londrina, Londrina, Brazil) for sharing information from his unpublished revision of Brazilian Leucospidae. Additionally we thank Ron Ochoa, Michael Gates, and Dave Smith for reviewing the manuscript, and Terry Nuhn and Linda Lawrence (all Systematic Entomology Laboratory, Beltsville, MD, and Washington, DC) for preparing Figures 1 and 2. We also thank Chris Starr (University of the West Indies, St. Augustine, Trinidad) for providing information on possible models for mimicry.

### LITERATURE CITED

- Bouček, Z. 1974a. A revision of the Leucospidae (Hymenoptera: Chalcidoidea) of the world. *Bulletin of the British Museum (Natural History) Entomology, Supplement* 23: 1–241.
- Bouček, Z. 1974b. Description of a new *Leucopsis* [sic] (Hymenoptera: Leucospidae) from Bolivia. *Studia Entomologica* 17: 430–432.
- Bouček, Z. and T. C. Narendran. 1981. The *Leucopsis* species of India and adjacent countries (Hymenoptera: Leucospidae). *Oriental Insects* 15: 1–15.
- Cameron, S. A. and S. R. Ramírez. 2001. Nest architecture and nesting ecology of the orchid bee *Eulaema meriana* (Hymenoptera: Apinae: Euglossini). *Journal of the Kansas Entomological Society* 74: 142–165.
- Chandler, L., J. A. F. Barrigossi, and E. B. S. Diaz. 1985. The first definitive host record for *Leucospis cayennensis* Westwood (Hymenoptera: Leucospidae). *Revista Ceres* 32: 170–174.
- Clausen, C. P. 1940. *Entomophagous Insects*. McGraw Hill, New York, NY. 688 pgs.
- Cooperband, M. F., R. A. Wharton, G. W. Frankie, and S. B. Vinson. 1999. New host and distribution records for *Leucospis* (Hymenoptera: Leucospidae) associated primarily with nests of *Centris* (Hymenoptera: Anthophoridae) in the dry forests of Costa Rica. *Journal of Hymenoptera Research* 8: 154–164.
- Engel, M. S. 2002. The first leucospid wasp from the fossil record (Hymenoptera: Leucospidae). *Journal of Natural History* 36: 435–441.
- Fabre, J. H. 1855. Observations sur les mœurs des *Cerceris*. *Annales des Sciences Naturelles (Zoologie et Biologie Animale)* 4: 129–150.
- Fritz, M. A. and J. A. Genise. 1980. Nota sobre nido de barro de Sphecidae (Hymenoptera) constructores, inquilinos, parasitoides, celptoparasitos y detritivoros. *Revista de la Sociedad Entomológica Argentina* 39: 67–81.
- Graenicher, S. 1906. The habits and life-history of *Leucospis affinis* (Say), a parasite of bees. *Bulletin of the Wisconsin Natural History Society* 4: 153–159.
- Habu, A. 1962. *Fauna Japonica. Chalcididae, Leucospidae, and Podagrionidae (Insecta: Hymenoptera)*. Biogeographical Society of Japan, Tokyo, Japan. 232 pgs., + 19 plates.
- Habu, A. 1977. A new *Leucospis* species from the Ryukyus, Japan (Hymenoptera: Leucospidae). *Entomological Review of Japan* 30: 47–51.
- Hanson, P. 1995. Chapter 11.10 Leucospidae. Pages 342–344. In P. H. Hanson and I. D. Gauld (editors), *The Hymenoptera of Costa Rica*. Oxford University Press, Oxford, UK. 893 pgs.
- Malyshev, S. I. 1968. *Genesis of the Hymenoptera, and the Phases of Their Evolution*. Methuen & Co., Ltd., London. (English translation of 1966 edition, Izdatelstvo 'Nauka', Moscow-Leningrad.)
- Naumann, I. D. 1981. A new species and additional records of *Leucospis Fabricius* (Hymenoptera: Leucospidae) from Australia. *Journal of the Australian Entomological Society* 20: 223–228.
- Noyes, J. S. 2001. *Interactive Catalogue of World Chalcidoidea (2001—second edition)*. CDrom. Taxapad and The Natural History Museum, London.
- Vieira de Jesus, B. M. and C. A. Garófalo. 2000. Nesting behaviour of *Centris (Heterocentris) analis* (Fabricius) in southeastern Brazil (Hymenoptera, Apidae, Centridini). *Apidologie* 31: 503–515.

## A Revision of *Bootania* Dalla Torre and Recognition of *Macrodasyceras* Kamijo (Hymenoptera: Torymidae)

E. E. GRISELL AND C. A. DESJARDINS

(EEG) USDA, Agricultural Research Service, PSI, Systematic Entomology Laboratory, c/o National Museum of Natural History, Washington, DC 20560-0168, USA, email: egrissel@sel.barc.usda.gov; (CD) Department of Entomology, University of Maryland, College Park, Maryland, 20742-0001, USA, email: desjar@wam.umd.edu

---

*Abstract.*—The genus *Bootania* Dalla Torre is revised and the genus *Macrodasyceras* Kamijo is removed from synonymy with it and returned to generic rank (revised status). Species included in *Bootania* are: *gigantea* (Girault), *leucospoides* (Walker), *maxima* (Strand), *neocaledonica* (Milliron), *pilicornis* (Cameron), *ruficeps* (Cameron), *solomonensis* (Milliron), and *titanus* (Girault). Species removed from *Bootania* to the genus *Macrodasyceras* are *hirsutum* Kamijo and *japonicus* (Ashmead) (both revised combinations). In this paper, redescriptions are given for the 8 known species of *Bootania*, and 4 new species are described: *orba* Desjardins and Grissell, *moorea* Desjardins and Grissell, *fascia* Grissell and Desjardins, and *xestos* Grissell and Desjardins. A lectotype is designated for *B. gigantea*. The holotype of *B. neocaledonica* is reported missing. An illustrated key is given for all species. Seven of the 12 known species have been reared from seeds of *Pandanus* and 1 was collected on *Pandanus*. Although hosts are unknown for the other 4 species it is likely that they are associated with the same host plant. Species of *Bootania* are Australasian, ranging from Bhutan, Burma, and Sri Lanka in the northwest, eastward to Republic of China and southward through Borneo/Sarawak, the Solomons, Papua New Guinea, New Caledonia, Fiji, Moorea, and northeastern Australia.

---

Species of *Bootania* Dalla Torre are giants among the Chalcidoidea, ranging up to 4.5 cm in length including the greatly exerted ovipositor (Fig. A). Since its recognition in 1862 (as *Metamorphia* Walker), eight species of *Bootania* have been described, four of which are phytophagous in seeds of *Pandanus* S. Parkinson (Pandanaaceae) and four of which have no known host. Currently recognized species include: *gigantea* (Girault), *leucospoides* (Walker), *maxima* (Strand), *neocaledonica* (Milliron), *pilicornis* (Cameron), *ruficeps* (Cameron), *solomonensis* (Milliron), and *titanus* (Girault) (Grissell 1999). These species are Australasian in distribution, ranging from Bhutan, Burma, and Sri Lanka in the northwest, eastward to Republic of China and southward through Borneo/Sarawak, the Solomons, Papua New Guinea,

New Caledonia, Fiji, Moorea, and northeastern Australia.

In this paper we redescribe all valid species of *Bootania*, describe 4 new ones (3 reared from *Pandanus*), provide an illustrated key for their identification, and summarize all known host and distribution data. Two additional species transferred to *Bootania* by Bouček (1988) are reinstated to their original genus, *Macrodasyceras* Kamijo, as explained below.

Seven of the 12 known species of *Bootania* have been reared from *Pandanus*, and it is likely that these wasps are restricted to seeds of this host plant. *Pandanus* has well over 700 described species that are widespread from "Africa to Asia and various archipelagos in the Pacific" (Stone et al. 1998). Several species of *Pandanus*, including the Tahitian screwpine (*Pandanus*

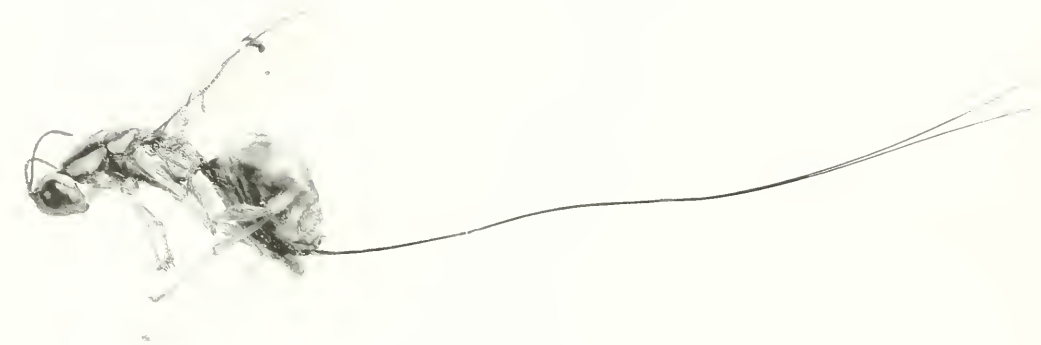

Fig. A. *Bootania maxima*, female, habitus.

*tectorius* Parkinson ex Zucc.), have been introduced into Hawaii and Puerto Rico (USDA, NRCS 1999), and evidence suggests that *Bootania orba* (see below) has been transported as well (specimens from "Malaysia" found at a San Francisco port of entry in 1970). Whether or not any *Bootania* species have been transported and established in other areas is unknown, but it is likely that *Pandanus* has been moved around various Pacific islands for centuries. They are of great economic importance to inhabitants of the region, providing edible leaves, fruits, seeds, spices, and fiber for baskets, roofing materials, and various domestic articles (California Rare Fruit Growers 1989, Stone et al. 1998).

Because there are so many species of *Pandanus*, because they are so widespread, and because each of the 12 known *Bootania* species comes from a widely divergent geographic area within the Australasian realm, it is likely that many species of *Bootania* remain to be discovered. This paper serves as a preliminary step in understanding the morphology, taxonomy, and host range of this group of wasps. No biological details are known for these large, widespread seed-feeders, except for individual host records.

The following abbreviations are used for institutions cited in the text: ANIC—Australian National Insect Collection, Canberra; BMNH—The Museum of Nat-

ural History, London; QM—Queensland Museum, Brisbane; UQ—University of Queensland, Brisbane; USNM—National Museum of Natural History, Washington, DC; ZMB—Zoologisches Museum, Berlin. We use the abbreviations F1, F2, etc. for funicle segment 1, 2, etc. In the descriptions, "body" refers to the mesosoma + metasoma and excludes the head.

### *Bootania* Dalla Torre

*Metamorpha* Walker 1862:346. Type species: *Metamorpha leucospoides* Walker (monotypic).

*Bootania* Dalla Torre 1897:86. Replacement name for *Metamorpha* Walker preoccupied by *Metamorpha* Hübner 1819:43 (Lepidoptera: Nymphalidae).

*Spilomegastignus* Cameron 1905:73–74. Type species: *Spilomegastignus ruficeps* Cameron (monotypic).

*Eutanycornus* Cameron 1909:209–210. Type species: *Eutanycornus pilicornis* Cameron (monotypic).

*Pulvilligera* Strand 1911:59. Type species: *Pulvilligera maxima* Strand (original designation).

Of the above generic names, Dalla Torre (1897) provided a replacement name for *Metamorpha* of Hübner (1819), Bouček (1988:127) synonymized *Spilomegastignus* and *Eutanycornus*, and Riek (in Kamijo 1962:36) synonymized *Pulvilligera*. We have studied the type species of each of these generic names, and agree with their synonymy.

Bouček (1988) synonymized *Macrodasyceras* Kamijo (1962) [type species: *Megastigmus japonicus* Ashmead, USNM, examined] with *Bootania*, but the reasons for doing so were not clear, and in any case we do not agree with this placement. In proposing the synonymy, Bouček first stated that "Kamijo [1962] used the length of the postmarginal vein (longer than marginal) for separation of *Macrodasyceras* from *Megastigmus* (at most as long as marginal)." This is actually the reverse of what Kamijo said for *Macrodasyceras* ("Marginal vein distinctly longer than postmarginal") and *Megastigmus* ("Marginal vein as long as or shorter than postmarginal"). Additionally Bouček stated that "... in Australian species of *Megastigmus* the postmarginal vein is also much longer than the marginal," thus agreeing in principal with Kamijo's characterization of *Megastigmus*. Bouček's argument, in fact, gives no reason to synonymize *Macrodasyceras* with *Bootania*, but rather to separate *Macrodasyceras* from *Megastigmus*.

Bouček (1988) also stated that *Macrodasyceras* and *Megastigmus* "... differ greatly in the male antennae." It is possible that the name *Megastigmus* was a mistake for *Bootania*, and that the point Bouček (1988) was making was that males of *Bootania* + *Macrodasyceras* both have whorled setae on funicle segments 1–7, and thus the latter should be synonymized with the former. Bouček (1988) gave no other reasons for the synonymy.

The recognition of *Macrodasyceras*, *Megastigmus*, and *Bootania* poses a difficult question of generic limits. Kamijo (1962), in his key to Japanese genera of Megastigminae, differentiated his new genus *Macrodasyceras* from *Megastigmus* with the following diagnostic characters: "marginal vein distinctly longer than postmarginal," "antennae inserted much above middle of face," with "scape extending beyond level of medial ocellus," "gaster of female with petiole more or less distinct," "first to fourth tergites deeply incised at apex,"

and funicle of male with "sparse, outstanding hairs which are as long as the funicle segment." We have compared these characters and others for *Macrodasyceras*, *Megastigmus*, and *Bootania*, and conclude that two of the synapomorphies given by Kamijo supports recognition of *Macrodasyceras*: the relatively short postmarginal vein (shorter than marginal), and the petiolate metasoma. These characters are not yet known in *Megastigmus* or *Bootania*. Additionally, *Macrodasyceras* are tiny wasps (less than 0.5 cm) reared from seeds of *Ilex* (Aquifoliaceae), whereas *Bootania* are huge wasps by comparison (2 cm and over) reared from seeds of *Pandanus*. Because of the morphological and biological differences, we remove *Macrodasyceras* from synonymy with *Bootania*, and return it to its original generic position (*revised status*). The only included species are *hirsutum* Kamijo and *japonicus* (Ashmead) (*revised combinations*), both of which are known from Japan (Ashmead 1904, Kamijo 1962, 1981 [key]).

The recognition of *Bootania* is actually more difficult to justify than that of *Macrodasyceras*. At first glance, species of *Bootania* appear distinct based (in part) upon their gigantic size, their exceptionally long postmarginal vein, the well-developed, heavily pigmented basal vein (Figs. 45, 46), and the male antenna with elongate funiculars from which arise erect or semi-erect setae longer than the width of the funicle (Fig. 38♂). Unfortunately all but the last of these morphological characters may also be found in *Megastigmus*, especially large species such as *M. albifrons* (Walker).

In Bouček's (1988) key to Australian genera of Torymidae, he used the following diagnostic characters to separate *Bootania* from *Megastigmus*: scape "slightly to considerably exceeding the vertex level," pronotum of female "dorsally long and flat," and male funicle "with long hairs arranged more or less in 2 whorls on each segment." Because of integration, the

use of the scape either in relation to its placement on the face, its length relative to the eye, or its length relative to the vertex has proven of no diagnostic value when comparing *Bootania* to *Megastigmus*. The longer-than-wide, parallel-sided pronotum appears to be diagnostic for *Bootania* (in *Megastigmus* it is generally wider than long, but in some species it is longer than wide), but we have not examined all known *Megastigmus* to confirm this. We have found in *Bootania* that the metabasitarsis is exceptionally long (generally equaling tarsomeres 2–5 combined),

and this may be diagnostic as well, though, again, this character needs to be compared to all 126 known species of *Megastigmus*. The male antenna is currently the only synapomorphy that clearly defines *Bootania*. Additionally, the unique plant host family (Pandanaeae) implies some degree of isolation from other species of *Megastigmus* (Grissell 1999). It is possible that *Bootania* will be found at most to be a species group of *Megastigmus*, but we retain the generic name until such time as the entire subfamily can be revised.

#### KEY TO SPECIES OF *BOOTANIA* DALLA TORRE

[This key is based largely on characters found in the females; males are unknown for 5 species as indicated below. The female of *pilicornis*, however, is essentially unknown so emphasis must be placed on the male of that species in comparison to others. In all species, dimorphism is expressed in males by the forewing being relatively more setose than in females and generally having the stigma wider and shorter (cf. Figs. 13, 15–17♀♂).]

1. Spiracle (Fig. 31) unique, set deeply within chamber encircled by lamelliform translucent rim (outwardly, rim appears to be enlarged spiracle); scrobal depression (Fig. 25) wider than parascrobal area; body mostly black, with few markings, dorsoventrally compressed, and almost entirely smooth (♂ unknown) ..... 12. *xestos* Grissell and Desjardins, new species
- Spiracle (Fig. 33) normal, set at surface of propodeum; scrobal depression (Figs. 23, 24, 26, 27) narrower than parascrobal area; body entirely yellow to orange brown, if approaching dark brown to black then body patterned (Figs. 4, 5, 6), laterally compressed, and at least scutum transversely carinate ..... 2
2. Propodeum (Fig. 32) with subcircular median area defined by semicircular submedian carinae curving to nucha; encircled area acarinate, either polished or reticulate ..... 3
- Propodeum (Figs. 33–37) without sub-circular median area, submedian carinae either absent, not reaching nucha (Fig. 34) or projecting straight to nucha (Fig. 37); medially irregularly carinate (except *moorea*, Fig. 34) ..... 4
3. Nucha a distinct, parallel sided band (as in Fig. 36); propodeum medially reticulate; basal cell setose (Fig. 45); stigma evenly surrounded by narrow brown stain, cubital and medial setal lines stained brown (Fig. 45) (♂ unknown) ..... 11. *titanus* Girault
- Nucha indistinct (Fig. 32); propodeum medially smooth; basal cell setose medially (Fig. 46); stigma with posteriorly elongated stain (Figs. 22, 46), remainder of wing hyaline (♂ unknown) ..... 9. *ruficeps* Walker
4. Interantennal area a raised lamelliform carina ending less than halfway to mid ocellus (Fig. 27) ..... 5
- Interantennal area a raised lamelliform carina reaching almost to mid ocellus (Fig. 26), though it may be less developed in mid- to upper half (Fig. 28) ..... 8
5. Tarsal claws bifurcate (Fig. 44); ventral margin of stigma concave (Fig. 14); female: stigmal vein shorter than stigmal width (Fig. 14♀) ..... 3. *leucospoides* Walker
- Tarsal claws simple (Fig. 43); ventral margin of stigma convex (Figs. 15–21); female: stigmal vein as long as or longer than stigmal width (Figs. 15–17, 19–22♀) ..... 6
6. Head in dorsal view (Fig. 23) with facial setae longer than greatest midocellus diameter and reaching (or nearly) inner eye margin (i.e., upper face without wide, bare area be-

- tween setae and inner eye margin); stigmal area entirely setose (Fig. 15♀) ..... 10. *solomonensis* Milliron  
 Head in dorsal view (Fig. 24) with facial setae shorter than greatest midocellus diameter and obviously not reaching inner eye margin (i.e., upper face with wide, bare area between setae and inner eye margin); stigmal area partially (Fig. 20) to completely (Fig. 17) bare ..... 7
7. Median carina of propodeum (Fig. 37) bifurcating to form submedian carinae that reach straight to nucha; no transverse carinae medially; stigmal bare in anterior half (Fig. 20) (♂ unknown) ..... 5. *moorea* Desjardins and Grissell, new species  
 Median carina of propodeum (Fig. 34) bifurcating and diverging widely toward postspiracular sulcus, not reaching nucha; several transverse median carinae present; stigmal area completely bare (Fig. 17) ..... 6. *neocaledonica* Milliron
8. Head (Fig. 28) with carinae extending from lower face at most to toruli; scrobal depression without lateral carinae (Fig. 28) ..... 2. *gigantea* (Girault)  
 Head (Fig. 26) with carinae extending from lower face nearly to venter of lateral ocelli; scrobal depression with well-developed lateral carinae that extend to midocellus (Figs. 26, 29, 36) ..... 9
9. Parapsidal line present (Fig. 9, 10); pronotum with transverse carinae nearly as well-developed as on mid lobe of scutum (Fig. 3); nucha a broad, distinct band anteriorly well defined (Figs. 35) ..... 10  
 Parapsidal line absent; pronotum with transverse carinae obscure, less well-developed than on mid lobe of scutum; nucha poorly defined, essentially absent (Fig. 33) ..... 11
10. Propodeum with median carina (Fig. 36); dorsum of head posteriorly with continuous dark band (Fig. 1); uncus at least 3× as long as wide (Fig. 19♀) (♂ unknown) ..... 1. *fascia* Grissell and Desjardins, new species  
 Propodeum without median carina (Fig. 35); dorsum of head posteriorly with 3 distinct dark spots (Fig. 2); uncus about as long as wide (Fig. 16) ..... 4. *maxima* Strand
11. Female and male: frenal line distinct, scutellum anteriorly with effaced longitudinal carinae, apical lamella distinctly pitted (Fig. 11); pronotum evenly faintly transversely carinate; male stigma about as wide as high, surrounded by brown stain (Fig. 13♂) ..... 7. *orba* Desjardins and Grissell, new species  
 Male (female states unknown, presumed same as male): frenal line absent, scutellum entirely polished, apical lamella faintly pitted (Fig. 12); pronotum smooth with few faint apical carinae; stigma as high as wide with no surrounding brown stain (Fig. 18♂) ..... 8. *pilicornis* Walker

**1. *Bootania fascia* Grissell and Desjardins, new species**

Figs. 1, 10, 19, 29, 36

*Female holotype*.—Body length (excluding ovipositor) 11 mm; ovipositor length about 25 mm. *Color*: Yellowish orange with brown markings as follows (Fig. 1): narrow median stripe from clypeus to interantennal area; transverse band through ocelli to eye, transverse band across dorsum of head posterior to lateral ocelli, medially reaching occipital carina; pronotum with median and lateral longitudinal stripes; midlobe of mesoscutum with me-

dian longitudinal stripe; lateral lobe of mesoscutum with median longitudinal stripe; notaulus; scutellum with median longitudinal stripe extending from apical margin to frenal line and narrowly to posterior of frenal area; lateral panel of axilla posteriorly; femoral depression and trans-epimeral sulcus; propodeum medially except for submedian yellow spots; base of metasomal tergum 2 medially and laterally, 3–5 mostly brown with yellow center (other terga not visible). *Head*: Wider than high (8:7); in dorsal view with facial setae longer than greatest midocellus diameter



1. *fascia* ♀



2. *maxima* ♀

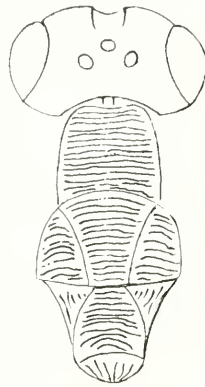

3. *maxima* ♀

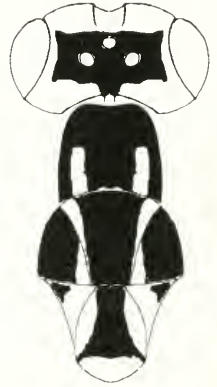

4. *pilicornis* ♂



5. *titanus* ♀



6. *leucospidoides* ♀

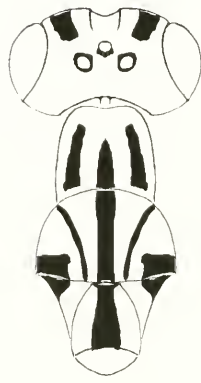

7. *orba* ♀



8. *orba* ♂

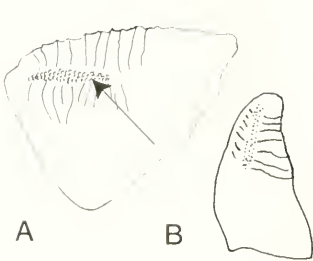

9. *maxima*

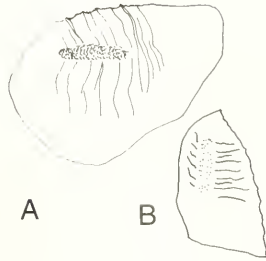

10. *fascia*

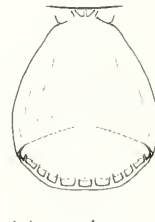

11. *orba*

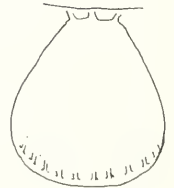

12. *pilicornis*

Figs. 1-12. *Bootania* spp. 1-8, Color pattern, except 3, sculpture pattern (all dorsal view, diagrammatic). 9-10, Lateral lobe of scutum, A = lateral view (arrow points to parapsidal line), B = dorsal view. 11-12, Scutellum (dorsal view).

and reaching (or nearly) inner eye margin (i.e., upper face without wide, bare area between setae and inner eye margin) (as in Fig. 23); upper face bulging slightly; face with carinae extending from lower margin (excluding clypeus) to venter of lateral ocelli; genal and postgenal areas smooth, scrobal depression faintly striate except obviously carinate below median ocellus; scrobal depression narrower than upper face (i.e., distance from lateral margin of depression to eye); scrobal depression laterally with nearly parallel carinae that converge on midocellus ventrally and laterally (Fig. 29); midocellus not distinctly in scrobal depression); malar sulcus complete and obvious; intermalar distance about  $3.0\times$  malar distance; toruli slightly higher than wide, about  $1.5\times$  own diameter above ventral eye margin, separated from each other by  $\frac{1}{2}$  shortest torulus diameter; interantennal area with raised lamelliform carina extending within ocellus diameter of venter of midocellus; scape about  $0.8\times$  eye height, laterally compressed; ratio of scape:pedicel:anellus: F1:F2 as 22:5:1:12:13; anellus wider than long; F1-2 as wide as pedicel, F1 about 43 as long as wide, each segment becoming shorter to F7  $2\times$  as long as wide, covered with appressed, dense, bristles, none longer than width of segment; clava about  $0.9\times$  length of F6+7; ratio of ocellocular: postocellar: mid-to-lateral ocellus distance: lateral ocellus diameter about 16:14: 5:12; frontovertex and transverse area behind ocelli slightly swollen (more pronounced posterolaterally); lateral ocelli slightly elevated medially, sitting in depression between frontovertex and transverse area, posteriorly margined by carina; wide furrow extending from lateral ocellus to eye outlined anteriorly by swollen frontovertex and posteriorly by posterolateral swellings (Fig. 29). *Mesosoma*: Pronotum with strong, transverse carinae, laterally smooth, about as long as wide, in lateral view slightly longer than high; mid- and lateral lobes of mesoscutum

with strong transverse carinae (similar to pronotum); notaulus deeply grooved, meeting transscutal articulation at point outside (laterad) scutoscutellar suture, notaulus with transverse carinae delimiting shallow pits; side lobes with parapsidal line present, finely granulose, not extending almost to apical margin (Fig. 10; separated from apex by length at least longer than own narrowest width), interrupting transverse carinae; apical margin of scutellum essentially contiguous with transscutal articulation except a single median pit present; axillae with diagonally curving carinae; scutellum dorsally flat, weakly transversely carinate anteriorly; frenal line absent but frenal area indicated by colored line and weak, longitudinal carinae; ratio scutellum length: fenum length about 2.5:1; scutellum posteriorly with grooved, pitted lamella; propodeum (Fig. 36) with complete median carina; submedian carina arise from median carina, forming acute angle about  $\frac{1}{3}$  distance from metanotum, posteriorly joining inner margin of spiracular sulcus, area anterior to carina alveolate (resultant area is yellow and may appear as rounded yellow circle); area posterior to carina partially alveolate and partially nearly flat; spiracle about  $0.5\times$  own greatest length from apical edge of propodeum, about  $2\times$  own length from metapleuron, about  $0.25\times$  median length of propodeum; postspiracular sulcus deep and traversed by 4 or 5 strong carinae forming deep pits, inner (upper) edge carinate, forming a distinct ledge in lateral view; callus convex with long whitish setae set in irregular alveolate depressions; nucha a parallel-sided curved strip, with fine, parallel striae; mesepisternum smooth; femoral depression deep, well defined, with longitudinal carinae; transepimeral sulcus strongly defined from middle of epimeron to venter, entire epimeron longitudinally carinate; metapleuron with longitudinal carinae about as well developed as epimeron, posterior margin (abutting propodeum) de-

pressed in lower half with several longitudinal carinae creating deep pits; metatibial spurs (see Variation below); dorsal length (shortest) of metabasitarsus about  $0.8\times$  length of tarsomeres 2–5; all tarsal claws simple (as in Fig. 43); forewing ratio of submarginal vein:basal vein:marginal vein:postmarginal vein about 16:3:5:11; costal cell dorsally without setae on apical anterior edge, ventrally densely setose in apical  $\frac{1}{2}$ , basal cell and cubital vein aseptose; petiolate segment of stigmal vein subequal to stigmal height, stigma height  $1.2\times$  width (Fig. 19), ventral margin convex, uncus 3–5 $\times$  as long as wide. *Metasoma*: Laterally compressed; ratio of mesosoma:metasoma:hypopygium about 11:12:15.

*Male*.—Unknown.

*Types*.—Holotype ♀ with following data: Jesselton, North Borneo [= Kota Kinabalu, Sabah, Malaysia], K. L. Leong, 18 May 1959, "on pandan" (deposited in BMNH); 2 ♀ paratypes, same data as holotype (BMNH, USNM).

*Variation*.—The three females are essentially identical. The holotype has the right leg missing beyond the femur and the right shorter metatibial spur is missing. On the other specimens this spur is about  $0.5\times$  the longer spur.

*Etymology*.—From the Latin "fascia" meaning stripe or band in reference to the stripe on the posterior of the head.

*Distribution*.—Known only from Malaysia (Sabah).

*Host*.—The type specimens were collected on "pandan" (presumably *Pandanus*).

*Discussion*.—This species appears nearly identical to *B. maxima*. It shares the facial carinae reaching or nearly reaching the lateral ocellus, the swollen frontovertex, the median ocellus set within (or nearly) the scrobal depression, the lateral ocelli set in slightly depressed areas which extend to the eye, the presence of distinct parapsidal lines, the strong transverse carinae on the dorsum of the pronotum and mesoscutum, and the relatively small, nearly

circular stigma. It differs in the following respects: the propodeum has a median carina (Fig. 36) (absent in *maxima*, Fig. 35); the sculpturing of the parapsidal line in dorsal view does not reach as far forward towards the anterior margin of the side-lobe (Fig. 10B) (in *maxima* the parapsidal line nearly touches the anterior margin, Fig. 9B); the dorsum of the head has a continuous band of black (or dark brown) extending across its posterior margin (Fig. 1) (in *maxima* there are 3 distinct spots, Fig. 2); the lateral ocelli are slightly raised and are set in a depressed area formed by the swollen frontovertex and posterior dorsum of head, they are outlined posteriorly by a distinct carina, and the furrow to the eye is wide and flat (Fig. 29) (in *maxima* the lateral ocelli are not raised above the surface but are set in a nearly flat plane that reaches to the occipital carina [raised swellings are present posterolaterad but not medially], there is no posterior carina, and the furrow to the eye is narrow, Fig. 30); the lateral carinae of the scrobal depression reach only the base or sides of the midocellus (Fig. 29) (in *maxima* the lateral carinae reach the dorsum of the midocellus, Fig. 30); and the uncus is 3 or more times as long as wide (Fig. 19) (in *maxima* the uncus is scarcely longer than wide, Fig. 16♀).

## 2. *Bootania gigantea* (Girault)

Figs. 28, 40, 43

*Pulvilligera gigantea* Girault 1928:3. Lectotype ♀, herein designated to ensure nomenclatural stability, Townsville, N. Q[ueensland] [G. F. Hill] [Australia] (QM, examined; missing head, left forewing; double-mounted on minuten and marked with E. E. Grissell identification label); 1 ♂ syntype, same data as ♀ (lost according to Dahms 1984).

*Bootania gigantea* (Girault): Transferred by Riek 1970:920.

*Female* (lectotype and specimens from Round Hill Head, see below).—Body length (excluding ovipositor) about 12 to 15 mm; ovipositor length about 20 to 25

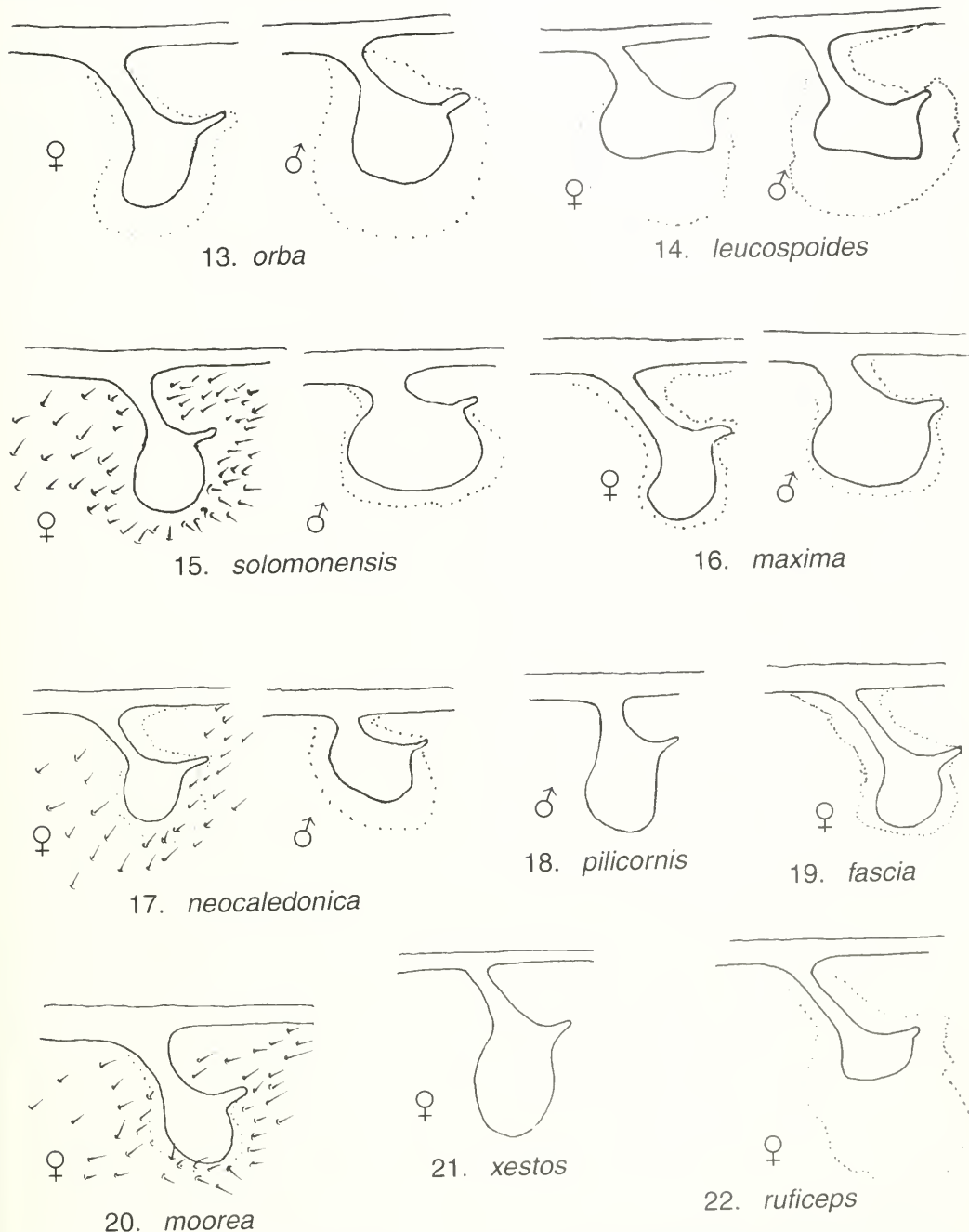

Figs. 13–22. *Bootania* spp. Right forewing, stigmal region, dorsal view (setae not shown except Figs. 15, 17, and 20). Stigmal stain indicated by dotted line.

mm. Color: All yellow to yellow with following areas pale reddish brown: pronotum laterally; lateral lobe of mesoscutum including notaulus; axillae; prepectus;

mesepisternum; metanotum laterad of dorsellum; metapleuron; darker reddish brown areas are: lower margin of face (including gena), propodeum; dark brown

are: funicle + clava, submarginal and stigmal veins, ovipositor sheath. *Head*: Barely wider than high; upper face swollen (Fig. 28); in dorsal view with facial setae shorter than greatest midocellus diameter and obviously not reaching inner eye margin (i.e., upper face with wide, bare area between setae and inner eye margin) (as in Fig. 24); face with carinae radiating from lower margin (excluding clypeus) to venter of toruli; genal area, postgenal area, and upper face smooth to finely reticulate; scrobal depression narrower than upper face (i.e., distance from lateral margin of depression to eye) (Fig. 28); scrobe in ventral half obscurely laterally carinate, carinae absent medially, several obscure carinae converge on midocellus ventrally and dorsally (Fig. 28; it is not clear if midocellus is in scrobal depression or not); malar sulcus present; intermalar distance about  $2.0\times$  malar distance; toruli as high as wide, venter about own diameter above ventral eye margin, separated from each other by about  $\frac{1}{2}$  torulus diameter, interantennal area a rounded lamelliform carina that continues as distinct but barely raised carina to venter of midocellus; scape about  $0.9\times$  eye height, laterally compressed; ratio of scape:pedicel:anellus:F1:F2 about 4:1:0.2:1.5:1.5 (Fig. 40); anellus wider than long; F1-2 scarcely wider than pedicel, F1-5 each about  $2\times$  as long as wide, F6-7 each about  $1.5\times$  as long as wide, covered with appressed, dense bristles, each shorter than width of segment; clava shorter in length than F6+7; ratio of ocellular:postocellar:mid-to-lateral ocellus distance:lateral ocellus diameter about 1.5:1:0.5:0.8. *Mesosoma*: Pronotum dorsally with transverse carinae, laterally smooth, in dorsal view slightly wider than long, in lateral view, slightly longer than high; mid- and lateral lobes of mesoscutum with transverse carinae (much closer together than on pronotum); notaulus deeply grooved, meeting transscutal articulation at point outside (laterad) scutoscuteellar suture, notau-

lus with transverse carinae delimiting shallow pits; parapsidal line barely discernible as depression, transverse carinae somewhat distorted in depression, but not interrupted by granulose sculpture; apical margin of scutellum widely contiguous with transscutal articulation; scutellum smooth, flat; frenal line absent; scutellum posteriorly with narrow lamella with narrow, smooth groove; propodeum apically with median carina that diverges widely posteriorly and reaches postspiracular sulcus (as in Fig. 34), medially with several parallel transverse carinae; spiracle about  $\frac{1}{2}$  own greatest length from apical edge of propodeum, about  $1.5\times$  own length from metapleuron, about  $\frac{1}{4}$  median length of propodeum; postspiracular sulcus deep and traversed by 1 or 2 strong carinae forming deep pits; metanotum posterolaterally lamellate, with longitudinal groove crossed by vertical carinae, deep pit laterad of dorsellum; dorsellum convex, smooth, not projecting; callus with few, long, whitish setae; nucha a narrow band, indicated laterally, indistinct medially; mesepisternum smooth to weakly reticulate, femoral depression shallow weakly sculptured, transepimeral sulcus a weakly developed pit, posterior half of mesepimeron with weak longitudinal carinae; metapleuron with well developed longitudinal carinae about as developed as on lateral margins of propodeum; dorsal length (shortest) of metabasitarsus about  $\frac{1}{2}$  length of tarsomeres 2-5; inner metatibial spur slightly curved, about  $3\times$  as long as outer; tarsal claws simple (Fig. 43); forewing ratio of submarginal vein:basal vein, marginal vein:postmarginal vein as about 7:1.5:2:4; costal cell without setae dorsally, ventrally with several rows of setae at distal  $\frac{1}{5}$ , basal cell and cubital vein asetose; petiolate part of stigmal vein nearly  $1.5\times$  stigmal height, stigma height about  $0.6\times$  width, ventral margin convex, uncus longer than wide. *Metasoma*: Laterally compressed; ratio of mesosoma:metasoma:hyopygium about 1:1:1.

*Male* (from Round Hill Head).—Body length about 10 to 12 mm. Similar in coloration and sculpture to female, except base of metasoma and edges of some terga may be reddish brown. Ratio of scape: pedicel: anellus: F1: F2 about 5:1:0.2:2:2, F1–7, each spindle-shaped, about 3× as long as wide, with 2 to 3 whorls of semi-erect setae as long as funicular segment; clava distinctly wider than funicle, slightly longer than F6+7, covered with short, appressed setae (as in female); petiolate part of stigmal vein about 0.6× stigmal height, stigma about 2× as wide as high; metasoma dorsoventrally compressed.

*Material examined*.—In addition to the lectotype ♀ we have seen the following material: 30 ♀, 29 ♂, Round Hill Head, Queensland, Australia, em. 10 Oct. to 7 Nov. 1997 from *Pandanus* seeds coll. 7 Sept. 1997, M. S. Upton (ANIC); 1 ♀, Eet Hill, vicinity Moa (Banks) Is., Torres Str., N. Qld, July 9–13 1977, G. B. Monteith and D. Cook (QM); 1 ♂, Coolum, 20-4-38, F. A. Perkins [Queensland] (UQ), 1 ♂, same data but 20-11-38 (ANIC); 1 ♀, Witsunday Is., N. Geary, Jan 1934 [Queensland] (QM); 1 ♂, Brisbane, Queensland, 17-3-36, H. Hacker; 1 ♀, Caloundra, Queensland, 30-3-34, H. Hacker (ANIC).

*Distribution*.—This species is known from a few localities in Queensland, Australia. Most are on the eastern coast near Brisbane, but one record is from the extreme northern tip of Queensland.

*Host*.—The species was reared from *Pandanus* seeds.

*Discussion*.—Dahms (1984) discussed the syntypes of which the male is missing. *Bootania gigantea* is easily distinguished from the other 2 known Australian species (i.e., *titanus*, *xestos*) by the all yellow dorsum of the head (mostly black in *titanus*, all black in *xestos*). It differs from *xestos* in a number of additional characters (mostly autapomorphies for *xestos*) as outlined under that species. It is difficult to compare to *titanus* because that species is known only from a badly broken single female

and all the facial and antennal characters are unknown. The prododea of the two differ as described in the key. *Bootania gigantea* differs from non-Australian species in having a combination of a complete lamelliform interantennal area, nearly smooth upper facial swellings, and lower face with carina extending to venter of the toruli (Fig. 28).

### 3. *Bootania leucospoides* (Walker)

Figs. 6, 14, 44

*Metamorphia leucospoides* Walker 1862:347. Lectotype ♀, "Bootan" (BMNH, designated by Boucek 1988:127, examined). [Missing are: left antenna beyond pedicel; right antenna beyond F2; right protarsus; left protarsus beyond tarsomere 2; both metatarsi beyond tarsomere 2.]

*Metamorphia leucospidoidea*: Rye 1874:362, incorrect subsequent spelling.

*Bootania leucospoides*: Transferred by Dalla Torre 1897:86.

*Female lectotype*.—Body length (excluding ovipositor) 10 mm; ovipositor length 21 mm. *Color*: Brownish yellow with following areas black (Fig. 6): upper margin of clypeus, median stripe to toruli narrowing dorsally; scrobe; area around ocelli, line descending into scrobe; stripe from ocellar area to dorsoposterior corner of eye; band extending around ocelli posteriorly to occipital foramen; pronotum in anterior half posteriorly branching into 2 bands along dorsolateral margins and around lateral margins, with median stripe extending to scutum; midlobe of mesoscutum medially; notauli; lateral lobe of mesoscutum with dorsolateral longitudinal band; anteriolateral portion of axillae; scutellum medially branching into stripes that run along anterior margin of frenum, and diffuse medial stripe on frenum; metanotum with spots laterad of dorsellum; propodeum dark reddish brown; femoral depression; venter of mesonotum; mesopleuron; outer surface of metacoxa; metafemur completely; tergum 1 mostly red-brown, terga 2–6 dark brown

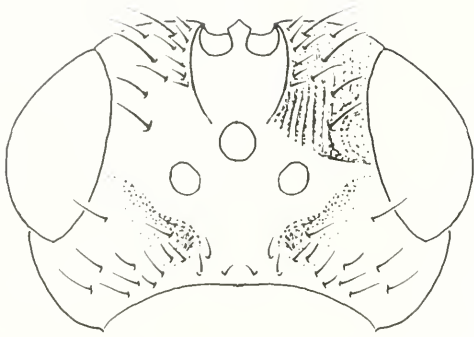

23. *solomonensis*

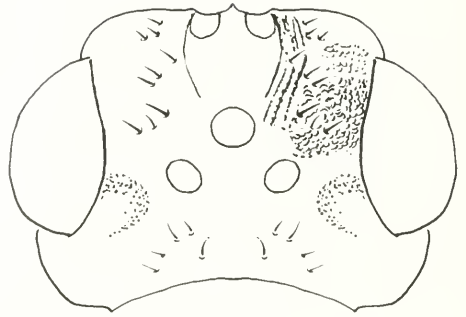

24. *neocaledonica*

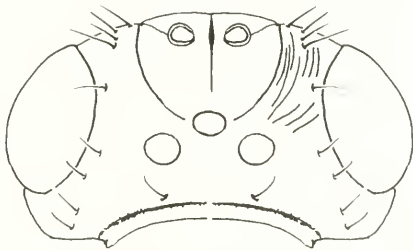

25. *xestos*

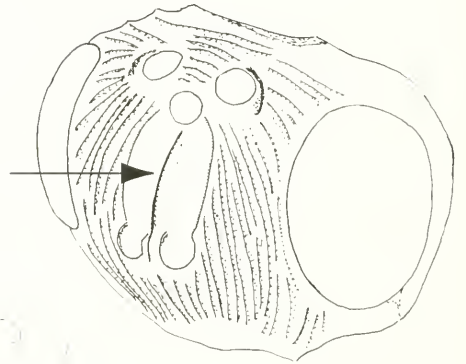

26. *orba*



27. *moorea*

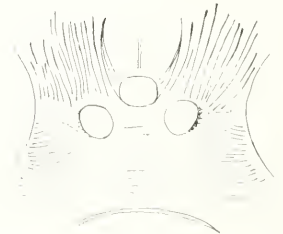

30. *maxima*

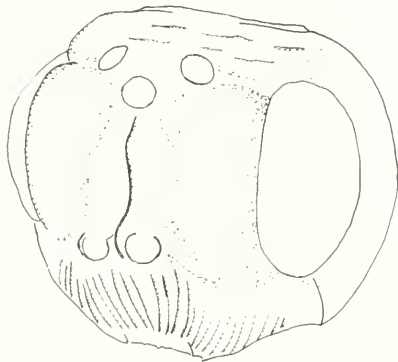

28. *gigantea*



29. *fascia*

Figs. 23-30. *Bootania* spp., heads. 23-25, Dorsal view. 26-28, Three-quarter dorsal view (27 showing interantennal area only). Arrow = interantennal carina. 29-30, Dorsal view, ocellar area only.

to black with off-white vertical band along anterior margin, widening ventrally; wing veins dark brown, stigma surrounded by narrow brown band (Fig. 14 ♀), forewing

with apparent brown stain in basal 1/3, extending along vein track of cubital and medial setal lines to margin of wing. *Head*: Wider than high (4:3.5); upper face swol-



31. *xestos*

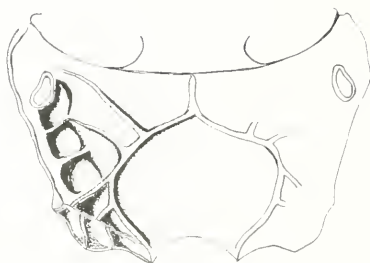

32. *ruficeps*



33. *orba*



34. *neocaledonica*

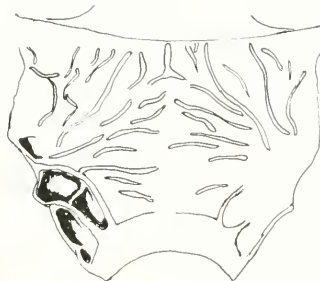

35. *maxima*

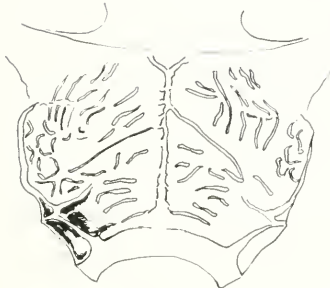

36. *fascia*

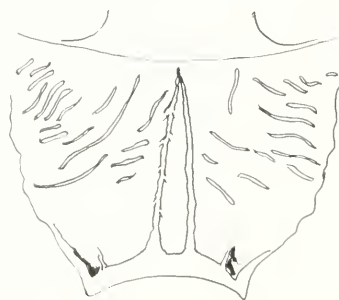

37. *moorea*

Figs. 31–37. *Bootania* spp. Propodeum, dorsal view. 31, 33, Inset, enlargement showing spiracle.

len, finely reticulate; in dorsal view with facial setae shorter than greatest midocellus diameter and obviously not reaching inner eye margin (i.e., upper face with wide, bare area between setae and inner

eye margin) (as in Fig. 24); face with faint carinae radiating from apical part of clypeus to venter of torulus; genal area, postgenal area, and area laterad lateral ocellus smooth; scrobal depression narrower than

upper face (i.e., distance from lateral margin of depression to eye); scrobe carinate laterally, fading dorsally, not extending to midocellus (i.e., midocellus not in scrobal depression); carinae present from upper swelling to venter of lateral ocellus; malar sulcus present; toruli slightly higher than wide, venter about own long diameter above ventral eye margin, separated from each other by  $\frac{1}{2}$  torulus diameter, inter-antennal area a rounded lamelliform carina not extending dorsad of toruli; intermalar distance about  $2.5\times$  malar distance; scape  $0.9\times$  eye height, laterally compressed; ratio of scape:pedicel:anellus: F1:F2 as  $5:1:0.3:3:3$ ; anellus as long as wide, F1, F2 as wide as pedicel [other measurements not taken], with appressed, dense, bristles, each less than width of segment; ratio of ocellocular:postocellar: mid-to-lateral ocellus distance: lateral ocellus diameter as  $5:2:0.8:2$ ; vertex slightly swollen, ocelli in slight depression, weak furrow extending from lateral ocellus to eye. *Mesosoma*: Pronotum dorsally and laterally smooth, without carinae, in dorsal view slightly wider than long, in lateral view, slightly longer than high; mid- and lateral lobes of mesoscutum smooth; notaulus deeply grooved, meeting transscutal articulation at same point as scutoscuteellar suture, notaulus and scutoscuteellar groove with transverse carinae delimiting deep pits; parapsidal line absent; apical edge of scutellum reaching transscutal articulation at median point, narrowly contiguous (i.e., appearing as acute angle) with deep pit on either side; scutellum smooth, flat, frenal line indistinct except at lateral edges (transverse translucent line indicates where frenal line would be if present), ratio scutellum length: frenal line length about  $3:1$ ; scutellum posteriorly with wide lamella rimmed by distinct pits; propodeum with numerous irregular carinae, dorsally with single asymmetric median carina, laterally with irregular carina reaching to nucha and encircling median area of anastomosing ca-

rinae; spiracle about  $0.75\times$  own greatest length from apical edge of propodeum, about  $1.5\times$  own length from metapleuron, about  $0.25\times$  median length of propodeum; postspiracular sulcus deep and traversed by 1 or 2 strong carinae forming deep pits; dorsellum convex, smooth, slightly projecting which creates overhang with flat to slightly depressed surface; callus with moderately dense, long, whitish setae; nucha a distinct raised band; mesepisternum smooth; femoral depression deep with well-delimited transverse carinae; transepimeral sulcus well-developed, indicated by a deep depression with pits created by cross-carinae; mesepimeron and metapleuron with strong longitudinal carinae; metatibial spurs slightly curved, longer spur about  $2\times$  length of shorter spur; all claws bifurcate (Fig. 44); forewing ratio of submarginal vein: basal vein: marginal vein: postmarginal vein as  $6:1:2:6$ ; costal cell without setae dorsally, ventrally with numerous setae along anterior margin and distal  $\frac{1}{2}$ , basal cell with cluster of dorsal setae apically, cubital vein a setose; petiolate segment of stigmal vein about  $0.5\times$  stigmal height, stigma height  $0.5\times$  width (Fig. 14♀), uncus about  $2\times$  as long as wide; venter of stigma concave (Fig. 14♀). *Metasoma*: Laterally compressed; ratio of mesosoma: metasoma: hypopygium about  $1:1:1$ .

*Male* (from Burma).—Body length 10.8 mm. Similar to female except: metacoxa and metafemur yellowish brown; off-white bands on tergites wider; no circles present on lateral margins of pronotum, only dorsolateral stripe; frenum entirely yellowish brown. F1–7 each spindle-shaped, about  $7\times$  as long as wide, with several whorls of semierect setae shorter than length of segment; clava distinctly wider than funicle [length not taken], with dense short appressed setae; metasoma dorsoventrally compressed. Stigma see Fig. 14♂.

*Variation*.—The Burma specimens have setose eyes. This condition is not apparent

on the lectotype in which the setae may have broken off.

*Material examined*.—Lectotype ♀, Bootan (BMNH, designated by Boucek 1988); 1 ♀, 1 ♂, Maymyo, Mandalay Dist., Burma, M. H. Desai Coll., 28.VII.1931 (BMNH, det. Ferriere).

*Distribution*.—Specimens are known only from Bhutan and Burma.

*Host*.—The species has been reared from *Pandanus*.

*Discussion*.—Milliron (1949: 348) discussed the nomenclature of this name and stated that *leucospidioidea* was incorrectly credited to Westwood (1874: 136) by Dalla Torre (1898: 315) when it should have been credited to Rye (1874: 362). Narendran (1994: 34–35, Figs. 26–29) redescribed the lectotype. According to Boucek (1988: 127) the record for this species is questionably Butung Island, southeast of Celebes. Narendran (1994) disagreed with this interpretation and so did Grissell (1999). According to the Harper's Gazetteer of the world (Smith 1855) Bootan (also spelled Bhotan) was the area that now corresponds to Bhutan. According to Boucek (1988: 127) the locality of Assam (India) given by Dalla Torre (1898: 315) is incorrect. This locality was not given by Walker (1862), but Assam borders Bhutan on the south and east, and so should not be dismissed outright.

*Bootania leucospoides* is the only species known to have bifurcate claws (Fig. 44), and in both sexes the stigmal vein is somewhat concave on the ventral margin (Fig. 14). The female is especially distinct in having the stigma much wider than high (Fig. 14♀).

#### 4. *Bootania maxima* (Strand)

Figs. A, 2, 3, 9, 16, 30, 35

*Pulvilligera maxima* Strand 1911:59. 6 ♂ syntypes, Taihanroku, Formosa [Republic of China] [ZMB, 3 examined].

*Bootania maxima*: Transferred by Riek in Kamijo 1962:36.

*Female*.—Body length (excluding ovi-

positor) 8 to 15 mm; ovipositor length 20 to 30 mm. *Color*: Orange to brownish orange (or rarely yellow) with brown to black markings as follows (Fig. 2): narrow median stripe from clypeus to interantennal area; transverse stripe through ocelli to eye, spot posterolateral to lateral ocellus, spot posterior to median ocellus with stripe running to occipital foramen (Fig. 16); irregular spot between eye and oral fossa at malar sulcus; postgenal area; pronotum with median and lateral longitudinal stripes; midlobe of mesoscutum with median dark brown longitudinal stripe; lateral lobe of mesoscutum with median longitudinal stripe ranging from faint indication (limited to median area of lobe) to black (extending from apical to posterior margins); notaulus; scutellum with dark brown longitudinal stripe medially extending from apical margin to frenal line or to posterior of frenal area; lateral panel of axilla with faint longitudinal patch; femoral depression; propodeum medially to nearly entirely except for submedian yellow spots; metasoma ranging from all orange to nearly black with 2 to 4 lateral yellow spots laterally. *Head*: Wider than high (9:8); upper face bulging slightly; in dorsal view with facial setae shorter than greatest midocellus diameter and obviously not reaching inner eye margin (i.e., upper face with wide, bare area between setae and inner eye margin) (as in Fig. 24); face with carinae extending from lower margin (excluding clypeus) to venter of lateral ocelli; genal area, postgenal area, and scrobal depression smooth; scrobal depression narrower than upper face (i.e., distance from lateral margin of depression to eye) (Fig. 30); scrobal depression laterally with multiple carinae that converge on midocellus ventrally and dorsally (Fig. 30); midocellus appears to be in scrobal depression, but if not readily apparent, then at least several carinae converge on it laterally and dorsally); malar sulcus complete and obvious; intermalar distance about 2.5× malar distance; toruli

slightly higher than wide, separated from each other by  $\frac{1}{2}$  shortest torulus diameter; interantennal area a raised lamelliform carina extending within an ocellus diameter of venter of midocellus (though it may be effaced somewhat at its midpoint); scape about  $0.7\times$  eye height, laterally compressed; ratio of scape:pedicel:anellus: F1:F2 as 25:7:2:13:13; anellus wider than long; F1-2 as wide as pedicel, F1-7 each about  $3-3.5\times$  as long as wide, covered with appressed, dense, bristles, none longer than width of segment; clava about  $0.8\times$  length of F6+7; ratio of ocellular: postocellar: mid-to-lateral ocellus distance: lateral ocellus diameter about 10:10: 5:7; vertex with slightly swollen carinate area posterolaterad of lateral ocellus; lateral ocelli sitting in nearly flat plane extending from anterior ocellus to occipital carina (between posterolateral swellings); narrowed furrow extending from lateral ocellus to eye outlined anteriorly by swollen frontovertex and posteriorly by posterolateral swellings (Fig. 30). *Mesosoma*: Pronotum with strong, transverse carinae (Fig. 3, 9), laterally smooth, about as long as wide, in lateral view slightly longer than high; mid- and lateral lobes of mesoscutum with strong transverse carinae (similar to pronotum); notaulus deeply grooved, meeting transscutal articulation at point outside (laterad) scutoscuteellar suture, notaulus with transverse carinae delimiting shallow pits; side lobes with parapsidal line present, finely granulose, extending almost to apical margin (Fig. 9A, B), interrupting transverse carinae; apical margin of scutellum contiguous with transscutal articulation except a single median pit may be present; axillae with diagonally curving carinae; scutellum dorsally flat, weakly transversely carinate anteriorly; frenal line absent but frenal area indicated by colored line and weak, longitudinal carinae (Fig. 2); ratio scutellum length:frenum length as 3:1; scutellum posteriorly with grooved, pitted lamella; propodeum (Fig. 35) without me-

dian carina, several submedian carinae curve toward posterolateral margin of propodeum forming depression in anterior  $\frac{1}{3}$ , area anterior to carina alveolate (resultant area is yellow and may appear as subrounded yellow circles if propodeum is largely black); spiracle about  $0.5\times$  own greatest length from apical edge of propodeum, about  $2\times$  own length from metapleuron, about  $0.20\times$  median length of propodeum; postspiracular sulcus deep and traversed by 3 or 4 strong carinae forming deep pits, inner edge not carinate or forming a distinct ledge in lateral view; callus convex with long whitish setae set in irregular alveolate depressions; nucha a parallel-sided curved strip, with fine, parallel striae; mesepisternum smooth; femoral depression deep, well defined, with longitudinal carinae; transepimeral sulcus strongly defined from middle of epimeron to venter, entire epimeron longitudinally carinate; metapleuron with longitudinal carinae about as well developed as epimeron, posterior margin (abutting propodeum) depressed in lower half with several longitudinal carinae creating deep pits; metatibial spurs straight, longer spur about  $2\times$  length of shorter spur; dorsal length (shortest) of metabasitarsus subequal to length of tarsomeres 2-5; all tarsal claws simple (as in Fig. 43); forewing ratio of submarginal vein:basal vein:marginal vein:postmarginal vein about 5.5:1:2.3:4.5; costal cell dorsally with 1 or 2 setae on apical anterior edge, ventrally densely setose in apical  $\frac{1}{2}$ , basal cell and cubital vein asetose; petiolate segment of stigmal vein about  $0.8\times$  stigmal height, stigma height  $1\times$  width (Fig. 16♀), ventral margin convex, uncus as wide as long. *Metasoma*: Laterally compressed; ratio of mesosoma: metasoma:hypopygium about 7:6:8.

*Male*.—Body length 9 to 12 mm. Similar to female except: median longitudinal black line on pronotum faint on some specimens; ratio of scape:pedicel:anellus: F1:F2 about; F1-7 each spindle-shaped, about  $6\times$  as long as wide, with 2 to 3

whorls of erect setae as long as funicular segment; clava distinctly wider than funicle, slightly longer than F6+7, covered with short, appressed setae (as in female); petiolate segment of stigmal vein about  $0.4\times$  stigmal height, stigma height  $0.7\times$  width (Fig. 16♂), ventral margin convex; metasoma dorsoventrally compressed.

*Material examined.*—In addition to the 3 ♂ syntypes from Republic of China (ZMB), we have also seen the following: 65 ♀, 56 ♂, mouth of Evelyn River, Guadalcanal, 23 August to 9 September, 1944, H. Milliron, ex *Pandanus* seeds (USNM).

*Distribution.*—This species is known from the Republic of China in the north and the Solomon Islands (Guadalcanal) in the south.

*Host.*—The syntypes were not reared. Based on specimens from Guadalcanal (USNM) described by Milliron (1950) this species was reared from seeds of *Pandanus upoluensis* Martelli, but the original labels on the specimens state only *Pandanus*.

*Discussion.*—Milliron (1950) saw no type material. He described the female, redescribed the male, and illustrated the stigmal venation of both sexes (his figs. 2–3) based on specimens from Guadalcanal. We have compared these specimens with 3 syntype males and they are conspecific. We did not designate a lectotype for this species because we saw only part of the series. The species was transferred to *Boontania* by implication (Riek in Kamijo 1962: 36).

The 121 specimens from Guadalcanal and 3 specimens from Republic of China differ little in color pattern, except a few males may have the black areas absent along the lateral margins of the pronotum and most of the ocellar area (at least the lateral brownish spots remain posterior to the lateral ocelli and around the median ocellus).

This is among the largest of chalcidoid wasps, reaching 4.5 cm in length with the exerted ovipositor. The species is most

similar to *B. fascia* and diagnostic characters are discussed under that species.

##### 5. *Boontania moorea* Desjardins and Grissell, new species

Figs. 20, 27, 37, 42

*Female holotype.*—Body length (excluding ovipositor) about 9 mm; ovipositor length about 15 mm. *Color:* Pale yellowish brown with following areas reddish brown: lateral longitudinal stripes on pronotum and lateral lobes of scutellum, eyes, circle directly surrounding ocelli; brown areas are: median longitudinal stripe on posterior half of pronotum which becomes a faint V-shaped ending at posterolateral margins of neck, posterior half of scutum, and scutellum anterior to frenum; anterior margin of propodeum; postspiracular sulcus; dorsal surface of scape and pedicel; stripe connecting lateral ocelli to median ocellus; eyes; dark brown areas are: flagellum; anterodorsal region of first metasomal tergite; ovipositor sheath; wing veins. *Head:* Barely wider than high; upper face swollen; in dorsal view with facial setae shorter than greatest midocellus diameter and obviously not reaching inner eye margin (i.e., upper face with wide, bare area between setae and inner eye margin) (as in Fig. 24); face with minute longitudinal carinae radiating from lower margin (excluding clypeus) to venter of toruli; vertex with minute longitudinal carinae radiating from ocellar triangle; genal area, postgenal area, and scrobal depression smooth; scrobal depression narrower than upper face (i.e., distance from lateral margin of depression to eye); scrobe not carinate laterally (i.e. midocellus not in scrobal depression); malar sulcus complete; intermalar distance about  $2.5\times$  malar distance; toruli slightly higher than wide, venter about  $1.8\times$  own diameter above ventral eye margin, separated from each other by  $\frac{1}{2}$  torulus diameter, interantennal area (Fig. 27) a rounded lamelliform carina that terminates less than  $\frac{1}{2}$  way to midocellus; scape about

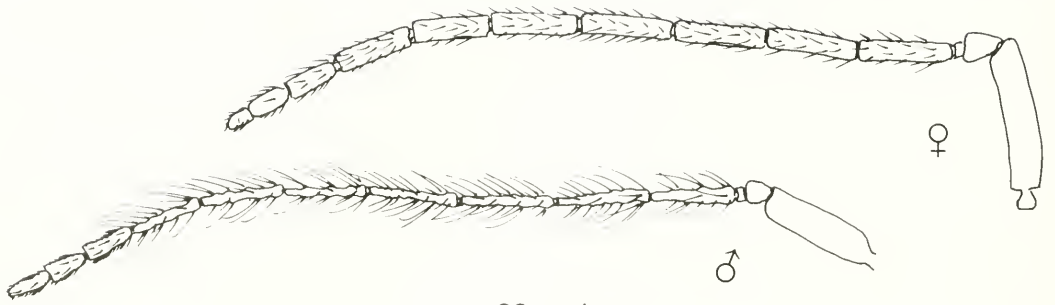

38. *orba*

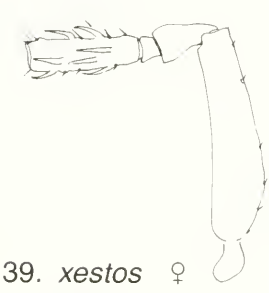

39. *xestos* ♀



40. *gigantea* ♀

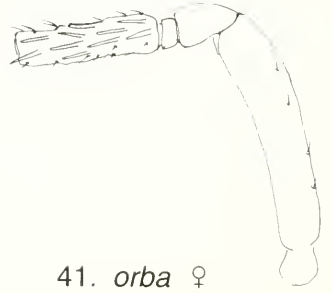

41. *orba* ♀

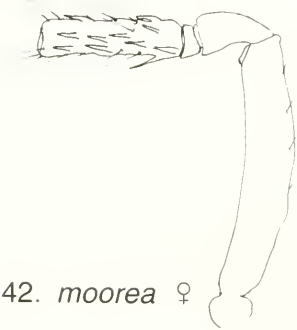

42. *moorea* ♀

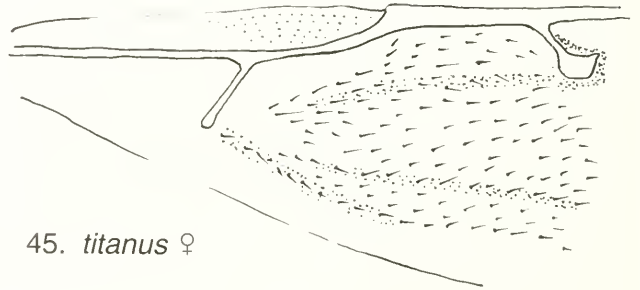

45. *titanus* ♀

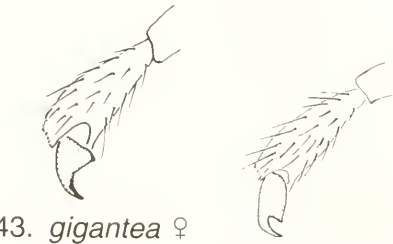

43. *gigantea* ♀

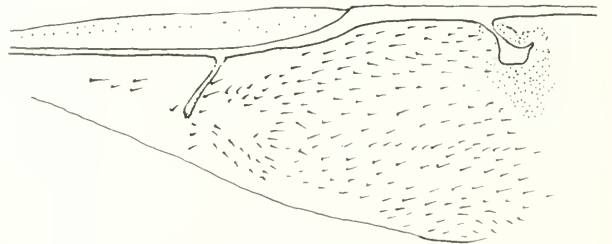

46. *ruficeps* ♀

44. *leucospoides* ♀

Figs. 38-46. *Bootania* spp. 38-42, Antenna, lateral view. 38, Entire. 39-42, Scape, pedicel, anellus, flagellomere 1. 43-44, Apical hindtarsus with claw (empodium not shown). 45-46, Forewing, dorsal view.

0.75× eye height, laterally compressed; ratio of scape:pedicel:anellus:F1:F2 about 3.5:1:0.2:2:2.2; anellus wider than long; F1–2 scarcely wider than pedicel, F1–4 each about 4× as long as wide, antennae broken beyond F4 (but in paratype F1–6 about 4× as long as wide, F7 about 3× as long as wide; clava about 0.8× length of F6+7), covered with appressed, dense bristles, each shorter than width of segment (Fig. 42); ratio of ocellocular:postocellar:mid-to-lateral ocellus distance:lateral ocellus diameter about 0.9:1:0.5:0.5. *Mesosoma*: Pronotum dorsally with faint transverse carinae, laterally smooth, in dorsal view barely longer than wide, in lateral view, slightly longer than high; mid- and lateral lobes of mesoscutum with faint transverse carinae (similar to pronotum); nettles deeply grooved, meeting transscutal articulation at point outside (laterad) scutoscuteellar suture, nettles with transverse carinae delimiting deep pits; parapsidal line absent; apical margin of scutellum contiguous with transscutal articulation; scutellum with minute transverse carinae anterior to frenum; frenal line distinct laterally but indiscernible medially; ratio of scutellum length:frenum length 1.1:1; scutellum posteriorly with narrow lamella and groove with well defined pits; propodeum (Fig. 37) weakly carinate; spiracle about 0.75× own length from apical margin of propodeum, about 1.4× own length from metapleuron, about 0.25× median length of propodeum; postspiracular sulcus deep and traversed by 2 strong carinae forming deep pits; callus as wide as postspiracular sulcus, with effaced transverse carinae and long, wide-spaced setae; dorsellum convex, smooth, not projecting; nucha a broad, well-defined band; mesepisternum smooth, delimited dorsally by strongly carinate ventral margin of femoral depression; femoral depression moderately shallow, well defined, with transverse carinae; transepimeral sulcus strongly developed from dorsal  $\frac{2}{3}$  of epimeron to venter, with

transverse carinae forming shallow pits, epimeron longitudinally; metapleuron with weak transverse carinae, posterior margin (abutting propodeum) deeply depressed with several longitudinal carinae creating deep pits; tarsi broken beyond tarsomere 3; tarsal claws simple (as in Fig. 43); inner metatibial spur slightly curved, about 3× as long as outer spur; forewing ratio of submarginal vein:basal vein:marginal vein:postmarginal vein about 4.7:1:1.8:3; costal cell without setae dorsally, ventrally with 3 to 4 rows of setae at distal  $\frac{1}{2}$ , more tightly spaced anteriorly than ventrally; basal cell with small cluster of setae on dorsal surface anterior to distal  $\frac{1}{2}$  of basal vein, cubital vein bare proximal to basal vein; petiolate segment of stigmal vein about 0.8× stigmal height, stigma about 1.1× as high as wide (Fig. 20), surrounded by narrow translucent brown band, ventral margin convex, uncus about 3× as long as wide. *Metasoma*: Laterally compressed; ratio of mesosoma:metasoma:hypopygium about 1:1:1.1.

*Male*.—Unknown.

*Types*.—Holotype ♀ with following data: [French Polynesia] Moorea, 20-IX-86, emerged from unripe *Pandanus* fruit, coll. M. Lee (deposited in USNM); 1 ♀ paratype, same data as holotype (USNM).

*Etymology*.—Named for the island of Moorea.

*Distribution*.—Known only from the French Polynesia island state of Moorea.

*Host*.—The type specimens were reared from seeds of *Pandanus*.

*Discussion*.—*Bootania moorea* may be distinguished by the propodeum that has two complete submedian carinae (Fig. 37), by the interantennal area not reaching more than half way to the midocellus (Fig. 27), and by the partially setose stigmal area (Fig. 20). Morphologically it is most similar to *neocaledonica*. Both species have a fairly small stigma with relatively asetose area between the uncus and the postmarginal vein (cf. Figs. 17, 20). They can

be separated by characters given in the key.

6. *Bootania neocaledonica* (Milliron)

Figs. 17, 24, 34

*Pulvilligera neo-caledonica* Milliron 1950:350–352.

Holotype ♀, Poindimie, New Caledonia (USNM, lost); 2 ♀, 2 ♂ paratypes same data as holotype (USNM, examined).

*Bootania neocaledonica*: Transferred by Bouček 1988:128.

*Female paratypes*.—Body length (excluding ovipositor) about 9 to 10 mm; ovipositor length about 18 mm. *Color*: Yellowish brown with following areas reddish brown: lateral longitudinal stripes on pronotum and lateral lobes of scutum, vertex, eyes, metasomal tergites; dark brown areas are: median longitudinal stripe on pronotum, scutum, and scutellum just prior to posterior edge; propodeum; anterodorsal region of first metasomal tergite; dorsal surface of scape and pedicel; flagellum; ovipositor sheaths; wing veins. *Head*: Barely wider than high; upper face swollen (as in Fig. 28); in dorsal view with facial setae shorter than greatest midocellus diameter and obviously not reaching inner eye margin (i.e., upper face with wide, bare area between setae and inner eye margin) (Fig. 24); face with obscure longitudinal carinae radiating from lower margin (excluding clypeus) to venter of swollen area, where sculpture varies from obscurely reticulate to obscurely carinate; genal area, postgenal area, and head behind eyes smooth; scrobal depression narrower than upper face (i.e., distance from lateral margin of depression to eye) (Fig. 24); scrobe carinate laterally, extending to dorsum of midocellus (i.e. midocellus in scrobal depression); malar sulcus complete; intermalar distance about 3× malar distance; toruli slightly higher than wide, venter slightly higher than own diameter above ventral eye margin, separated from each other by ½ torulus diameter, interantennal area a rounded lamelliform carina reaching less than ½ way to mido-

cellus (as in Fig. 27); scape about 0.7× eye height, laterally compressed; ratio of scape:pedicel:anellus:F1:F2 about 3.8:1:0.3:2.1:2.1; anellus wider than long; F1–2 as wide as pedicel, F1–5 each about 3× as long as wide, F6–7 about 2× as long as wide, covered with appressed, dense bristles, each shorter than width of segment; clava shorter in length than F6+7; ratio of ocellocular:postocellar:mid-to-lateral ocellus distance:lateral ocellus diameter about 0.9:1:0.4:0.5. *Mesosoma*: Pronotum dorsally with transverse carinae, laterally smooth, in dorsal view slightly longer than wide, in lateral view, longer than high; mid- and lateral lobes of mesoscutum with transverse carinae (similar to pronotum); notaulus deeply grooved, meeting transscutal articulation at point outside (laterad) scutoscutellar suture, notaulus with transverse carinae delimiting deep pits; parapsidal line absent; apical margin of scutellum widely contiguous with transscutal articulation, separated by groove with longitudinal carinae delimiting pits; scutellum smooth, slightly convex; frenal line indiscernible; ratio of scutellum length:frenum length 1.6:1; scutellum posteriorly with marginal rim lamelliform and groove with well defined pits; propodeum (Fig. 34) apically with median carina that branches widely posteriorly with each branch reaching postspiracular sulcus, several complete or incomplete transverse carinae present medially, two longitudinal carinae project ½ to dorsellum; spiracle about 0.6× own length from apical margin of propodeum, about 1.1× own length from metapleuron, about 0.25× median length of propodeum; postspiracular sulcus deep and traversed by 6 or 7 strong carinae forming deep pits; callus slightly wider than postspiracular sulcus anteriorly, but much narrower posteriorly, with effaced transverse carinae and long, widespaced setae; dorsellum convex, smooth, slightly projecting; nucha a broad, well defined band; mesepisternum smooth, delimited dorsally by

strongly carinate ventral margin of femoral depression; femoral depression moderately shallow, well defined, with transverse carinae; transepimeral sulcus strongly developed from dorsal  $\frac{2}{3}$  of epimeron to venter, entire epimeron longitudinally carinate anteriorly to transversely carinate posteriorly; metapleuron with longitudinal carinae, posterior margin (abutting propodeum) deeply depressed with several longitudinal carinae creating deep pits; dorsal length (shortest) of metabasitarsus about  $0.6\times$  length of tarsomeres 2–5; tarsal claws simple; inner metatibial spur straight, about  $2\times$  as long as outer spur; forewing ratio of submarginal vein: basal vein: marginal vein: postmarginal vein about 5.5:1.9:4; costal cell without setae dorsally, ventrally with 2 to 3 rows of setae at distal  $\frac{1}{2}$ ; basal cell with several setae on dorsal surface adjacent to midpoint of basal vein, cubital vein bare; petiolate segment of stigmal vein about  $0.9\times$  stigmal height, stigma about  $1.1\times$  as high as wide (Fig. 17♀), surrounded by narrow translucent brown band, ventral margin convex, uncus about  $4\times$  as long as wide. *Metasoma*: Laterally compressed; ratio of mesosoma: metasoma: hypopygium about 1.1:1:1.

*Male paratypes*.—Body length 9.0 to 10.0 mm. Similar to female except dorsum of metasoma dark brown. Ratio of scape: pedicel: anellus: F1: F2 as 5:1:0.4:4.5:4.8, F1–7 each cylindrical, about 6 to  $7\times$  as long as wide, with 3 to 5 whorls of outstanding setae which are about  $0.8\times$  length of segment; clava barely wider than funicle, about  $0.6\times$  length of F6+7, covered with short appressed setae; pronotum with transverse carinae obvious; costal cell with numerous rows of setae along anterior margin of ventral surface, in addition to many setae in distal half; petiolate section of stigmal vein (Fig. 17♂) about  $0.2\times$  as long as stigmal height, stigma about  $0.8\times$  as high as wide, roundish, surrounded by brown stain extending posteriorly half as far as stigmal height;

uncus about  $3\times$  as long as wide; propodeal nucha a narrow but distinct band, indicated laterally, indistinct medially; metasoma ventrally compressed.

*Material examined*.—The holotype of *neocaledonica* is supposed to be in the USNM (Milliron 1950:351–352). Although the remainder of the type series (2 ♀, 2 ♂ clearly marked as allotype and paratypes) is in the collection, the holotype cannot be found in either the type collection or the main collection. The type catalog lists 5 specimens as having been entered, including the holotype. The holotype, therefore, must now be considered lost.

*Distribution*.—Specimens are known from New Caledonia and perhaps Fiji (see discussion).

*Host*.—According to Milliron (1950) the types were reared from seeds of *Pandanus tectorius* var. *neocaledonicus* Martelli, but the original labels on the specimens state only *Pandanus*.

*Discussion*.—Milliron (1950) stated that he had seen one additional male from Suva, Fiji. The specimen is extant (USNM), and we have seen it but it differs from typical *B. neocaledonica* in having the interantennal area developed as a carina reaching to the midocellus. This single male specimen appears similar to *B. gigantea*, but differs in some aspects of the stigma, interantennal area, and propodeum. At present we cannot place this single, fragmentary specimen from Fiji.

*Bootania neocaledonica* is among the species without a well-developed interantennal area and is morphologically most similar to *moorea*. Both species have a fairly small stigma with relatively asetose area between the uncus and the postmarginal vein (cf. Figs. 17, 20). They differ (as described in the key) in characters found in the stigmal area (cf. Figs. 17 and 20) and on the propodeum (cf. Figs. 34 and 37).

#### 7. *Bootania orba* Desjardins and Grissell, new species

Figs. 7, 8, 11, 13, 26, 33, 38, 41

*Female holotype*.—Body length (excluding ovipositor) 5.4 mm; ovipositor length

10.8 mm. *Color*: Pale yellow to brownish yellow with brown and off-white markings as follows (Fig. 7): brown patch between scrobe and eye, and encompassing ocelli; pronotum with brown median and lateral longitudinal stripes fading out toward anterior and posterior edges (off-white between stripes); midlobe of mesoscutum with median dark brown longitudinal stripe, laterad with off-white area reaching to dark brown notaulus; lateral lobe of mesoscutum with off-white triangular area between posterolateral notaulus and posterolateral brown patch; inner corner of axilla off-white, laterally dark brown; scutellum white with dark brown longitudinal stripe reaching to anterior edge of frenum, lateral panel of axilla dark brown; metanotum brown except dorsellum off-white; propodeum dark brown; wing veins dark brown. *Head*: Distinctly wider than high (5:4); upper face not swollen; in dorsal view with facial setae longer than greatest midocellus diameter and reaching (or nearly) inner eye margin (i.e., upper face without wide, bare area between setae and inner eye margin) (as in Fig. 23); face (Fig. 26) with carinae radiating from lower margin (excluding clypeus) to venter of toruli; genal area, postgenal area, and scrobal depression smooth; scrobal depression narrower than upper face (i.e., distance from lateral margin of depression to eye); scrobe carinate laterally, extending to dorsum of midocellus (i.e., midocellus in scrobal depression); malar sulcus complete but obscure ventrally; intermalar distance  $2.3\times$  malar distance; toruli higher than wide, venter about  $1.5\times$  own diameter above ventral eye margin, separated from each other by about  $\frac{1}{2}$  longest torulus diameter, interantennal area a raised lamelliform carina that continues within an ocellus diameter of venter of midocellus (Fig. 26); scape  $0.9\times$  eye height, laterally compressed; ratio of scape:pedicel:anellus:F1:F2 about 16:3.5:1:9:9 (Fig. 41); anellus wider than long; F1-2 as wide as pedicel, F1-6 each

about  $5\times$  as long as wide, F7 about  $4\times$  as long as wide, covered with appressed, dense, bristles (Fig. 38♀), some longer than width of segment; clava  $0.5\times$  length of F6+7; ratio of ocellocular:postocellar:mid-to-lateral ocellus distance:lateral ocellus diameter about 1:1:0.3:0.7; lateral ocelli with carinae nearly reaching their posterolateral margin (Fig. 26). *Mesosoma*: Pronotum polished dorsally with faint transverse carinae, laterally smooth, in dorsal view slightly wider than long, in lateral view, slightly longer than high; mid- and lateral lobes of mesoscutum with faint transverse carinae (similar to pronotum); notaulus outlined laterally by indistinct carinae, with transverse carinae delimiting deep pits, with meeting transscutal articulation at point outside (laterad) scutoscutellar suture; parapsidal line absent; apical margin of scutellum not contiguous with transscutal articulation, separated by 2 round submedian pits each with indistinct pit laterad (Fig. 11); scutellum flat, smooth, with vague longitudinal carinae anteriorly; frenal line weakly present medially but obvious at lateral margins, ratio scutellum length:frenum length 2.5:1; scutellum posteriorly with narrow lamella and groove with pits (Fig. 11); propodeum strongly irregularly alveolate, most pronounced at margins (Fig. 33); spiracle about  $0.5\times$  own length from apical edge of propodeum, about  $1.8\times$  own length from metapleuron, about 0.25 median length of propodeum; postspiracular sulcus deep and traversed by 3 or 4 strong carinae forming deep pits; callus subequal in width to postspiracular sulcus, with effaced transverse carinae and long, widespaced setae; dorsellum convex, smooth, not projecting; nucha [not visible in female, see male description below]; mesepisternum smooth, delimited dorsally by strongly carinate ventral margin of femoral depression; femoral depression deep, well defined, with longitudinal carinae; transepimeral sulcus strongly developed from middle of epimeron to ven-

ter, entire epimeron longitudinally carinate; metapleuron with longitudinal carinae about as well developed as on epimeron, posterior margin (abutting propodeum) deeply depressed with several longitudinal carinae creating deep pits; dorsal length of metabasitarsus (shortest length) about  $\frac{2}{3}$  length of tarsomeres 2–5; tarsal claws simple (as in Fig. 43); both metatibial spurs curved, longer spur about  $2\times$  length of shorter spur; forewing ratio of submarginal vein:basal vein:marginal vein:postmarginal vein as 6:3:1.3:4; costal cell without setae dorsally, ventrally with 1 row along anterior margin, 2 or 3 rows in distal  $\frac{1}{2}$ ; basal cell with 1 or 2 setae on dorsal surface, cubital vein basally with row of setae on underside (only); forewing surface beyond basal vein almost completely covered with setae except small bare area proximal to parastigma; petiolate segment of stigmal vein subequal to stigmal height, stigma nearly  $2\times$  as high as wide (Fig. 13♀), surrounded by narrow translucent brown band, ventral margin convex, uncus  $2\times$  as long as wide. *Metasoma*: Laterally compressed; ratio of mesosoma:metasoma:hypopygium about 5.5:5.5:6.

*Male*.—Body length 5.4–7.2 mm. Similar to female except corresponding brown areas broader (Fig. 8); dorsum of metasoma brownish. Ratio of scape:pedicel:anellus: F1:F2 as 5:1:0.3:4:4, F1–7 each cylindrical, about 6 to  $7\times$  as long as wide, with 3 to 4 whorls of outstanding setae as long or nearly as long as segment; clava barely wider than funicle, subequal in length to F6+7, covered with short appressed setae (Fig. 38♂); pronotum with transverse carinae obvious; costal cell with numerous rows of setae along anterior margin of ventral surface, in addition to many setae in distal half; petiolate section of stigmal vein (Fig. 13♂)  $0.66\times$  as long as stigmal height, stigma as high as wide, roundish, surrounded by brown stain extending posteriorly half as far as stigmal height; uncus  $2\times$  as long as wide; propodeal nu-

cha a narrow band, indicated laterally, indistinct medially; metasoma ventrolaterally compressed.

*Types*.—Holotype ♀ with following data: "Malaysia, (San Fran[cisco] POE [Port of Entry]), June 10, 1970, Sd [seed] *Pandanus aurantiacus*, Patterson" (deposited in USNM); 2 ♂ paratypes, same data (USNM).

*Etymology*.—The name is derived from the Latin "*orba*" meaning "orphan" in reference to the unknown precise geographic origin of this species.

*Distribution*.—The original area of collection was given only as "Malaysia."

*Host*.—The type specimens were reared from seeds of *Pandanus aurantiacus* Ridl.

*Discussion*.—Males of this species are phenetically similar to the male paralecotype of *pilicornis* in size, coloration, the midocellus within carinate scrobal depression, the lamelliform interantennal carina, the face carinate from the clypeus to the lower margin of the lateral ocelli, and in not having the upper face swollen. Although only the metasoma of female *pilicornis* is known, it is likely that most of the characters cited below will work for females as well. The stigmal shape may be an exception because it is generally dimorphic in *Bootania* (and megastigmines in general). The following characters may be used to separate males: *orba* has the pronotum evenly transversely carinate (*pilicornis* is essentially smooth with a few faint carinae apically); *orba* has a distinct frenal line laterally, apically the scutellum is longitudinally carinate, and posteriorly the apical lamella is evenly pitted (Fig. 11) (in *pilicornis* there is no sign of a frenal line and apically the scutellum is completely smooth, Fig. 12); *orba* has the stigma (Fig. 13♂) wider than high, surrounded by a brown stain, and the stigmal vein arises from the marginal at an angle (*pilicornis* has the stigma higher than wide, no surrounding brown stain, and the stigmal vein is nearly perpendicular to the marginal, Fig. 18); and in *orba* the lateral ocelli

have carinae nearly reaching their posterolateral margin (Fig. 26) (in *pilicornis* the area is slightly depressed and nearly smooth). The only known male of *pilicornis* is missing its antennae, so we cannot compare this feature with *orba*.

Specimens of this species were reared from *Pandanus* fruits imported from Malaysia that were intercepted at the San Francisco Port of Entry. No more specific data are available.

### 8. *Bootania pilicornis* (Cameron)

Figs. 4, 12, 18

*Eutanycornus pilicornis* Cameron 1909:210. Lectotype ♀ [designated by Bouček 1988:127], Kuching, Sarawak, Borneo (BMNH, examined; all that remains is the abdomen with ovipositor pinned to a point by minutin); 1 ♂ ?paralectotype [designated by Bouček 1988:127], Quop, Sarawak (BMNH, on minutin, examined).

*Bootania pilicornis*: Transferred by Bouček 1988:127.

*Female lectotype*. [Because only the metasoma remains of the lectotype, the description that follows cites salient details from Cameron (1909) in quotes with the articles removed; we have seen no additional females of this species.]—Body length “5 mm; ovipositor, 8 mm.” *Color*: “Black, smooth, and shining, sparsely covered with longish black hair, . . . antennal scape and legs rufo-testaceous, . . . mandibles and oral region of a slightly darker rufo-testaceous colour, . . . wings hyaline, nervures blackish, . . . stigmal spot longish oval.” *Head*: Antennae with “third joint [F-1] distinctly longer than . . . fourth [F2];” “flagellum densely pilose;” “transverse furrow at . . . base of . . . scutellum, from either side of which a shorter oblique one runs along the sides.” *Mesosoma*: “Metanotum [?mistake for mesonotum], except the outer edges [?side lobes], transversely rugose;” “metapleurae [metapleuron] smooth above, . . . lower part striated at . . . base, . . . rest coarsely aciculated, . . . middle [?femoral depression] broadly de-

pressed. *Metasoma* (from specimen): Length of gaster 2 mm; laterally compressed, reddish brown, ventral half with pale, whitish yellow stripes on last 4 or 5 terga fading into same color completely ventrally.

*Male paralectotype*. [This specimen is described in detail because the only known female lacks all head and mesosomal characters. The paralectotype male is missing its funiculars, and the data concerning these is cited from Cameron (1909) in quotes.]—Body length 6 mm. *Color* (Fig. 4): Almost entirely yellow (to whitish yellow) except brown are: transverse band on face beginning behind ocelli and extending midway down scrobe; dorsum of pronotum except submedian narrow yellow stripes extending from posterior margin anteriorly  $\frac{2}{3}$  way to anterior margin; outer margin of side lobe, median band extending from anterior of mid lobe to frenal line; median and lateral areas of propodeum; dorsum of metasoma (except submedian yellow spot on metasomal tergum 2). *Head*: Wider than high (5:4); upper face not swollen; in dorsal view with facial setae longer than greatest midocellus diameter and reaching (or nearly) inner eye margin (i.e., upper face without wide, bare area between setae and inner eye margin) (as in Fig. 23); face with carinae extending from lower margin (excluding clypeus) to venter of lateral ocelli; genal area, postgenal area, and scrobal depression smooth; scrobal depression narrower than upper face (i.e., distance from lateral margin of depression to eye); scrobe carinate laterally, extending to dorsum of midocellus (i.e., midocellus in scrobal depression); malar sulcus present but barely indiscernible ventrally; intermalar distance about  $2.5\times$  malar distance; toruli higher than wide, venter about own short diameter above ventral eye margin, separated from each other by about  $\frac{1}{2}$  shortest torulus diameter, interantennal area a raised lamelliform carina that continues to within ocellus diameter of venter of midocellus;

scape about  $0.9\times$  eye height, laterally compressed; "joints of flagellum [F1-7] fringed with longish stiff hair;" "[club] thicker than others, closely shortly pilose"; ratio of ocellular:postocellar:mid-to-lateral ocellus distance:lateral ocellus diameter about 1.4:1:0.3:0.7; area between lateral ocelli depressed, inner margins of ocelli raised above area, distinct circular depressed area on outer margin, about long diameter of ocellus. *Mesosoma*: Flattened, pronotum and propodeum nearly in same plane; pronotum dorsally mostly smooth, polished, with transverse carinae in anterior  $\frac{1}{3}$  and several carinae in posterior  $\frac{1}{3}$ , laterally smooth, in dorsal view slightly longer than wide, in lateral view,  $0.6\times$  as long as high; mesoscutum with obvious transverse carinae [minutin obscures most of area], though somewhat obscure on lateral areas of lateral lobes, remainder of mesosoma dorsally polished except along outer edge of notaulus (i.e., inner margin of lateral lobe); notaulus outlined laterally by indistinct carinae, with transverse carinae delimiting deep pits; notaulus meeting transscutal articulation at point outside (laterad) scutoscuteellar suture; parapsidal line absent; apical margin of scutellum not contiguous with transscutal articulation, separated by ill-defined pitlike depressions (Fig. 12); scutellum smooth, flat; frenal line absent, posteriorly with flat, projecting lamella not delimited by groove (some obscure carinae may be seen perpendicular to lamella) (Fig. 12); propodeum covered with irregular carinae, some forming pits, obscure median triangle indicated by diagonal carinae branching from anterior edge, in dorsal view median area appearing elevated and separated from postspiracular groove by carina; spiracle in dorsal view about  $0.7\times$  own greatest length from apical edge of propodeum, about  $1.3\times$  own length from metapleuron, about  $0.2\times$  median length of propodeum; postspiracular sulcus deep and traversed by 2 strong carinae forming 3 deep pits; callus subequal

in width to postspiracular sulcus, with e-faced transverse carinae and long, wide-spaced setae; dorsellum convex, smooth, not projecting; nucha a wide band with transverse carinae; mesepisternum smooth to weakly reticulate; femoral depression deep, transversely crossed with distinct carinae, transepimeral sulcus a deep pit dorsally, continuing as shallow, pitted groove to mesepisternum; posterior half of mesepimeron strongly carinate; metapleuron medially smooth, with well developed longitudinal carinae around margin; dorsal length (shortest) of metabasitarsus about  $\frac{1}{2}$  length of tarsomeres 2-5; inner metatibial spur straight, about  $2\times$  as long as outer spur; tarsal claws simple (as in Fig. 43); forewing ratio of submarginal vein:basal vein, marginal vein:postmarginal vein as about 6:1.2:1.5:3.6; costal cell dorsally with several setae on apical anterior edge, ventrally entirely setose; basal cell with several setae on ventral surface and 1 dorsally, cubital vein a setose; stigmal vein almost perpendicular to marginal vein, petiolate segment of stigmal vein  $0.3\times$  stigmal height, stigma height  $1.2\times$  width (Fig. 18), ventral margin convex, uncus longer than wide. *Metasoma*: Dorsoventrally compressed.

*Material examined*.—Only the lectotype female (metasoma) and paralectotype male have been seen.

*Distribution*.—This species is known only from Malaysia (Sarawak).

*Discussion*.—Cameron (1909) based generic characters for his new genus *Eutanycornus* primarily on the male, emphasizing both the "densely pilose antennae" and the oblique vein issuing from the submarginal (i.e., the prominent basal vein). He based the species description of *pilicornis*, the only included species, entirely on the female. Bouček (1988:127) discussed the problems involved with selecting a lectotype for this species. He chose the female, which consisted of only the metasoma. It was not clear if the male should be considered a paralectotype of *pilicornis*,

and to confuse the matter even more, the specimen is labeled "Eutanycornus longicollis Cam", which according to Bouček (1988) is a manuscript name. There is not even certainty that the two sexes are correctly associated. Cameron (1909) stated that the female was black, yet the male is mostly yellow.

In the lectotype female, the ovipositor is greater than  $3\times$  the length of the metasoma (100:30), but it is obviously broken off. According to the original description the ovipositor was 8 mm; the metasoma is 2 mm by current measurement, and so the length of the ovipositor should be about  $4\times$  that of the metasoma. The metasoma has 5 indistinct yellow spots laterally, and this may be the primary basis for recognizing the female of this species at the present time.

The single known male of *pilicornis* most closely resembles males of *orba*, and the two are compared extensively under the latter species.

### 9. *Bootania ruficeps* (Cameron)

Figs. 22, 32, 46

*Spilomegastigmus ruficeps* Cameron 1905:74. Lectotype ♀ (designated by Bouček 1988:127), "Kandy, Ceylon" (BMNH, examined). [Missing both antennae beyond pedicel; left hind leg including coxa; abdomen detached, glued to same card.]

*Bootania ruficeps*: Transferred by Bouček 1988: 127.

*Female lectotype*.—Body length 7 mm; ovipositor 17 mm. *Color*: Body reddish orange, except following areas yellow (not well differentiated from body color): apical two-thirds of midlobe of scutum, shoulder of side lobes, axillae, clypeus, malar area, dorsellum, all legs including coxae, five circular spots on sides of metasoma (sixth area may be seen, but weakly developed); dark mahogany brown are forewing veins, stain around stigma, most of metasoma. *Head*: Wider than high (11:9); upper face not swollen; in dorsal view with facial setae longer than greatest mi-

docellus diameter and reaching (or nearly) inner eye margin (i.e., upper face without wide, bare area between setae and inner eye margin) (as in Fig. 23); face with distinct carinae radiating from malar area around clypeus to venter of lateral ocellus; scrobal depression narrower than upper face (i.e., distance from lateral margin of depression to eye); scrobe carinate laterally, disappearing halfway to midocellus (i.e., midocellus not in scrobal depression); malar sulcus present; intermalar distance about  $2.5\times$  malar distance; toruli slightly higher than wide, venter about  $3\times$  own long diameter above venter of eyes, separated from each other by  $\frac{1}{2}$  torulus diameter, carina present between toruli extending less than  $\frac{1}{2}$  torulus diameter upward; scape cylindrical, not reaching vertex; ratio scape to pedicel *ca* 4:1 (remainder of both antennae missing); ratio of ocellocular:postocellar:mid-to-lateral ocellus distance:lateral ocellus diameter as 21:21:9:11. *Mesosoma*: Pronotum smooth, with fine transverse, carinae seen only at some angles of view, in dorsal view wider than long (4:3), in lateral view longer than high (5:4); mid- and lateral lobes of mesoscutum with distinct transverse ridges, in anterior half these ridges curve forward medially; notaulus deeply grooved, meeting transscutal articulation at same point as scutoscutellar suture; parapsidal line absent; apical edge of scutellum flush with transscutal articulation, appearing broadly contiguous; scutellum highly polished with few weak transverse carinae apically; ratio of scutellum length:frenum length 3:1; frenum not physically indicated (i.e., no sulcus), but indicated by line under integument that lacks pigment, thus apparent frenal line; scutellum posteriorly with narrow lamella rimmed by obscure pits; propodeum (Fig. 32) dorsally with single median carina branching posteriorly as submedian carinae which circle around and meet nucha at sides, these carinae delimit essentially flat, polished median area; four carinae (on each side) branch off subme-

dian carina onto lateral areas of propodeum; spiracle about  $\frac{1}{2}$  half its own greatest length from apical edge of propodeum, about  $1.5\times$  own length from metanotum, about  $\frac{1}{4}$  median length of propodeum; postspiracular sulcus indicated by 3 or 4 distinct pits, propodeum with broad lamella at each posterolateral corner; metanotum mostly obscured by glue, dorsellum convex, smooth, unmodified; nucha lamelliform (i.e., not evident as parallel-sided, raised band); femoral depression and side of mesosoma obscured by glue; inner hindtibial spur straight, about  $1.7\times$  length of outer spur; metatarsal claw simple with subapical dorsal seta; forewing (Fig. 46) ratio of submarginal vein:basal vein:marginal vein:postmarginal vein as 11:2:5:8; costal cell without setae dorsally, ventrally with 1 or 2 rows along anterior margin, distal area with 3 or 4 rows, basal cell with a few setae medially, cubital vein aetose; petiolate segment of stigma about  $2\times$  stigmal height, stigma height  $1.5\times$  width (Fig. 22), ventral margin convex, uncus longer than wide. *Metasoma*: Laterally compressed, ratio of mesosoma:metasoma:hypopygium as 7:9:9.

*Male*.—Unknown.

*Material examined*.—We have seen only the lectotype female of this species.

*Distribution*.—Sri Lanka.

*Discussion*.—Narendran (1994) redescribed the lectotype female. In the lectotype, the presence of a frenal area appears to be indicated by a transparent line, but it has no physical groove; additional specimens are required to determine the status of this character.

*Bootania ruficeps* appears distinct based on the nearly smooth, flattened median area of the propodeum (Fig. 32), a character found only in *B. titanus* (though somewhat reticulate rather than smooth). The nucha of *ruficeps* is indistinct (Fig. 32; distinct in *titanus*, as in Fig. 36) and in *ruficeps* the stigma has an elongated stigmal stain (Figs. 22, 46; not elongated in *titanus*, Fig. 45) with the remainder of the fore-

wing hyaline (Fig. 46; some vein tracts stained in *titanus*, Fig. 45).

#### 10. *Bootania solomonensis* (Milliron)

Figs. 15, 23

*Pulvilligera solomonensis* Milliron 1950:352–354 (Figs. 6–7). Holotype ♀, 6 mi. from mouth of Tenaru River, Guadalcanal, Solomon Islands, 13 August 1941, H. E. Milliron, ex seed of *Pandanus* (USNM, examined); 44 ♀, 25 ♂ paratypes same data as holotype (USNM, 44 ♀, 21 ♂ examined; 4 ♂ specimens missing). *Bootania solomonensis*: Transferred by Bouček 1988:128.

*Female paratypes*.—Body length (excluding ovipositor) about 6 to 9 mm; ovipositor length about 10 to 17 mm. *Color*: Yellowish brown with following areas reddish brown: median longitudinal stripe on pronotum, posterior half of scutum, and scutellum anterior to frenum; anterodorsal region of first metasomal tergite; stripe connecting posterior ocelli to anterior ocellus; eyes; dark brown areas are: dorsal surface of scape and pedicel; flagellum; ovipositor sheaths; wing veins. *Head*: Barely wider than high; upper face not swollen; in dorsal view with facial setae longer than greatest midocellus diameter and reaching (or nearly) inner eye margin (i.e., upper face without wide, bare area between setae and inner eye margin) (Fig. 23); face with minute longitudinal carinae radiating from lower margin (excluding clypeus) to venter of ocelli; genal area, postgenal area, and scrobal depression smooth; scrobal depression narrower than upper face (i.e., distance from lateral margin of depression to eye); scrobe carinate laterally, extending to  $\frac{1}{2}$  ocellar diameter below venter of midocellus (i.e., midocellus not in scrobal depression); malar sulcus complete; intermalar distance about  $2.75\times$  malar distance; toruli as high as wide, venter about  $2.8\times$  own diameter above ventral eye margin, separated from each other by slightly less than 1 torulus diameter, interantennal area a rounded lamelliform carina which terminates 1 to

rulus diameter dorsal to toruli; scape about  $0.7\times$  eye height, laterally compressed; ratio of scape:pedicel:anellus: F1:F2 about 3.5:1:0.2:2.1:2.1; anellus wider than long; F1-2 scarcely wider than pedicel, F1-5 each about  $4\times$  as long as wide, F6 about  $3\times$  as long as wide, F7 about  $2\times$  as long as wide, covered with appressed, dense bristles, each shorter than width of segment; clava about  $0.8\times$  length of F6+7; ratio of ocellocular:postocellar:mid-to-lateral ocellus distance:lateral ocellus diameter about 1:1:0.4:0.5. *Mesosoma*: Pronotum dorsally with faint transverse carinae, laterally smooth, in dorsal view barely longer than wide, in lateral view, slightly longer than high; lateral and posterior  $\frac{2}{3}$  of midlobe of mesoscutum with faint transverse carinae (similar to pronotum); nettles deeply grooved, meeting transscutal articulation at point outside (laterad) scutoscuteellar suture, nettles with transverse carinae delimiting deep pits, separated by 4 rounded submedial pits; parapsidal line absent; apical margin of scutellum widely contiguous with transscutal articulation, separated by shallow groove with longitudinal carina delimiting pits; scutellum smooth, flat; frenal line weakly present medially but indiscernible laterally; ratio of scutellum length:frenum length 2.2:1; scutellum posteriorly with marginal rim lamelliform and groove with ill defined pits; propodeum regularly carinate; spiracle about  $0.6\times$  own length from apical margin of propodeum, about  $1.5\times$  own length from metapleuron, about  $0.25\times$  median length of propodeum; postspiracular sulcus deep and traversed by 2 or 3 strong carinae forming deep pits; callus slightly wider than postspiracular sulcus, with effaced transverse carinae and long, widespaced setae; dorsellum convex, smooth, not projecting; nucha a faint, narrow band indistinct medially but discernible laterally; mesepisternum smooth, delimited dorsally by strongly carinate ventral margin of femoral depression; femoral depression moderately shal-

low, well defined, with transverse carinae; transepimeral sulcus weakly developed from middle of epimeron to venter, epimeron longitudinally carinate anteriorly to transversely carinate posteriorly; metapleuron with weak longitudinal carinae, posterior margin (abutting propodeum) deeply depressed with several longitudinal carinae creating deep pits; dorsal length (shortest) of metabasitarsus about  $0.7\times$  length of tarsomeres 2-5; tarsal claws simple; inner metatibial spur slightly curved, about  $3\times$  as long as outer spur; forewing ratio of submarginal vein:basal vein:marginal vein:postmarginal vein about 4.1:1:1.6:3; costal cell without setae dorsally, ventrally with 4 to 5 rows of setae at distal  $\frac{3}{4}$ , more tightly spaced anteriorly than ventrally; basal cell with several setae on dorsal surface adjacent to posterior  $\frac{1}{2}$  of basal vein, cubital vein basally without setae; petiolate segment of stigmal vein about  $0.7\times$  stigmal height, stigma about  $1.5\times$  as high as wide (Fig. 15♀), surrounded by narrow translucent brown band, ventral margin convex, uncus about  $2\times$  as long as wide. *Metasoma*: Laterally compressed; ratio of mesosoma:metasoma:hypopygium about 1:1.2:1.1.

*Male*.—Body length 7 to 8 mm. Similar to female except corresponding brown areas broader; dorsum of metasoma dark brown. Ratio of scape:pedicel:anellus:F1:F2 as 5:1:0.2:3.5:4, F1-7 each cylindrical, about 8 to  $10\times$  as long as wide, with 3 to 5 whorls of outstanding setae about  $0.7\times$  length of segment; clava barely wider than funicle, about  $0.8\times$  length of F6+7, covered with short appressed setae; pronotum with transverse carinae obvious; costal cell with numerous rows of setae along anterior margin of ventral surface, in addition to many setae in distal half; petiolate section of stigmal vein (Fig. 15♂) about  $0.2\times$  as long as stigmal height, stigma about  $0.7\times$  as high as wide, roundish, surrounded by brown stain extending posteriorly about  $0.25\times$  as far as stigmal height; uncus about  $3\times$  as long as wide;

propodeal nucha a very narrow but distinct band; metasoma ventrally compressed.

*Material examined*.—We have seen no specimens other than the types. A large part of the type series (65 of 69 specimens) is in the USNM collection.

*Distribution*.—Specimens are known only from the Solomon Islands (Guadalcanal).

*Host*.—The types were reared from *Pandanus* seed.

*Discussion*.—*Bootania solomonensis* is distinguished by the combination of an undifferentiated median area on the propodeum, the undeveloped interantennal area (as in Fig. 27), the simple tarsal claws (as in Fig. 43), the setose stigmal area (Fig. 15), and the head without a swollen upper face (Fig. 23).

### 11. *Bootania titanus* (Girault)

Figs. 5, 45

*Epimegastigmus titanus* Girault 1938:147–148.

Holotype ♀, "south-east Papua" (QM, examined). [Badly fragmented: thorax on point with right forewing, right foreleg, (missing tarsomere 5), left forecoxa, left leg (missing all tarsi); glued on label are: head (broken and face down in glue), pieces of antenna (as noted below), one midleg, a femur, metasoma (ovipositor sheaths separate).]

*Megastigmus titanus*: Transferred by Milliron 1949:353.

*Bootania titanus*: Transferred by Bouček 1988: 128.

*Female holotype*.—Mesosoma + metasoma about 10 mm (head broken); ovipositor length about 21 mm. *Color* (Fig. 5): Brownish to black with following areas yellow: postgenal area extending from malar area to dorsum of head, dorsally curving onto occipital area almost to foramen; pronotum dorsally with two submedian spots, laterally with ventral spot extending half way to dorsum; lateral lobe of mesoscutum with submedian longitudinal bands from apex to posterior margins; scutellum (except median longitudi-

nal brown strip) and inner portions of axillae; metanotum; callus of propodeum; metapleuron; outer surface of coxae; terga 2, 4, and 6; wing veins dark brown, stigma surrounded by narrow brown stain, brown stain extending along entire vein tracks of cubital and medial setal lines (about  $\frac{1}{5}$  apex of wing missing). *Head* (only posterior half visible; antennae in pieces): Area surrounding ocelli with fine transverse carinae; ratio of anellus:F1:F2 as 1:10:10; F1, F2 as wide as pedicel, anellus as long as wide; funicular segments with semi-erect, dense, bristles, each about equal to width of funicle; F1–5 about 5× longer than wide; ratio of ocellular:postocellar:mid-to-lateral ocellus distance: lateral ocellus diameter as 14:10:5:6. *Mesosoma*: Pronotum dorsally with fine, transverse carinae, laterally smooth, in dorsal view longer than wide; in lateral view, slightly longer than high; mid- and lateral lobes of mesoscutum with fine, transverse carinae (similar to pronotum); notaulus deeply grooved, meeting transscutal articulation at point outside (laterad) scutoscuteellar suture, notaulus with transverse carinae delimiting shallow pits; parapsidal line absent; apical margin of scutellum narrowly contiguous (not meeting at a single point); scutellum smooth, flat, frenal line absent; apical half with median, longitudinal depression; posteroapically with wide lamella with distinct longitudinal carinae delimiting pits; propodeum medially reticulate surrounded by symmetrical submedian carinae from which radiate somewhat irregular carinae; spiracle about  $\frac{1}{3}$  own greatest length from apical edge of propodeum, 1.5× own length from metapleuron, about  $\frac{1}{4}$  median length of propodeum; neither postspiracular sulcus nor callus well defined, area deeply depressed to metapleuron, at least 1 strong posterolateral carina forming deep depression; dorsellum convex, smooth, not projecting; area corresponding to callus without setae; nucha a distinct raised collar; femoral depression

with well-delimited carinae forming pits; transepimeral sulcus distinct, divided into pits by transverse carinae; mesepimeron and metapleuron with transverse carinae; [data on inner metatibial spur not recorded], foreleg and midleg each with simple tarsal claw (as in Fig. 43); forewing (Fig. 45) ratio of submarginal vein:basal vein, marginal vein:postmarginal vein as 8:1.5:2:4; costal cell without setae dorsally, ventrally with several rows of setae at distal  $\frac{1}{2}$ ; basal cell aseptose; cubital vein without setae; petiolate segment of stigmal vein  $0.7\times$  stigmal height, stigma height about  $0.9\times$  width, ventral margin straight, uncus longer than wide. *Metasoma*: Laterally compressed; ratio of mesosoma:metasoma:hypopygium about 1:1:1.2 (hypopygium exceeds metasomal apex, but this may be artifact of drying).

*Male*.—Unknown.

*Material examined*.—We have seen only the holotype female from Papua.

*Distribution*.—Known so far only from Papua New Guinea.

*Discussion*.—The only known specimen is the female type. *Bootania titamus* is morphologically similar to *ruficeps* (also known only from the female) based largely on the medially encircled area of the propodeum (as in Fig. 32). The species differ primarily in the wing in which *titamus* has the stigma evenly surrounded by a narrow brown stain (Fig. 45; *ruficeps* with a posteriorly elongated stain, Fig. 46) and the cubital and medial vein tracks are stained brown (Fig. 45; *ruficeps* with wing vein tracks hyaline, Fig. 46).

## 12. *Bootania xestos* Grissell and Desjardins, new species

Figs. 21, 25, 31, 39

*Female holotype*.—Body length (excluding ovipositor) 6.7 mm (ovipositor length not measurable because it is hair-like and curled). *Color*: Black except the following yellow: face below midpoint of eyes, sides of pronotum, ventral area beneath pronotum, fore- and midlegs (including

coxae), hindleg (excluding coxa), wing veins dark brown. *Head*: Distinctly wider than high (3:2); upper face barely swollen; in dorsal view with facial setae longer than greatest midocellus diameter and reaching (or nearly) inner eye margin (i.e., upper face without wide, bare area between setae and inner eye margin) (Fig. 25); face with faint carinae from dorsal edge of clypeus to midpoint of eyes, absent between upper margin of clypeus and venter of toruli; weak carinae present across band of ocelli and hind margin of head (anterior to occipital carina); scrobal depression (Fig. 25) wider than upper face (i.e., distance from lateral margin of depression to eye), with weak lateral carina extending nearly to venter of midocellus (i.e., midocellus not in scrobal depression); malar sulcus complete; intermalar distance about  $2.5\times$  malar distance; toruli as high as wide, venter about  $1.3\times$  own diameter above ventral eye margin, separated from each other by about 1 torulus diameter; interantennal area with slightly lamelliform carina reaching barely  $\frac{3}{4}$  distance to midocellus; scape subequal to eye height, ventrally flat, dorsally rounded, tapered from base to apex; ratio of scape:pedicel:anellus: F1:F2 as 14:3.5:1:7:7; anellus nearly as wide as long; F1-2 as wide as pedicel, F1  $4\times$  as long as wide, each segment becoming shorter to F7 about  $2\times$  as long as wide, covered with erect bristles all longer than width of segment; clava subequal to length of F6+7; ratio of ocellocular:postocellar:mid-to-lateral ocellus distance:lateral ocellus diameter about 3:3:1:2. *Mesosoma*: Flattened pronotum and propodeum nearly in same plane; pronotum polished dorsally with faint transverse wrinkles anteriorly, laterally smooth, in dorsal view slightly wider than long, in lateral view, slightly longer than high; mid- and lateral lobes of mesoscutum polished, no carinae; notaulus widening gradually from anterior to posterior with transverse carinae delimiting

distinct pits, meeting transscutal articulation at point outside (laterad) scutoscutellar suture; parapsidal line absent (obscure depression may be seen at some angles of view); apical margin of scutellum contiguous with transscutal articulation; scutellum flat, smooth; frenal line absent; scutellum posteriorly with wide lamella and groove with ill-defined pits; scutellum, metanotum, and propodeum in same plane; propodeum with pattern of carinae as shown in Fig. 31; areas between carinae flat, shagreened; in dorsal view median area appearing elevated and separated from postspiracular groove by carina; spiracle (Fig. 31, inset) set within chamber formed by upward projecting cuticular structure encircled by translucent rim (outwardly chamber, itself, appears to be much enlarged spiracle); actual spiracle (not chamber opening) about  $0.75\times$  own length from apical edge of propodeum, about  $1.5\times$  own length from metapleuron, about  $0.25$  median length of propodeum; postspiracular sulcus deep and traversed by several irregular carinae forming deep pits; callus subequal in width to postspiracular sulcus, nearly smooth and without widespaced setae; dorsellum flat, smooth; nucha poorly defined; mesepisternum smooth; femoral depression well defined, with longitudinal carinae; transepimeral sulcus weakly developed from middle of epimeron to venter; metapleuron essentially smooth, posterior margin (abutting propodeum) deeply depressed as sulcus of uniform width throughout; dorsal length of metabasitarsus (shortest length) about  $0.9\times$  length of tarsomeres 2–5; tarsal claws simple; both metatibial spurs straight, longer spur about  $2\times$  length of shorter spur; forewing ratio of submarginal vein: basal vein:marginal vein:postmarginal vein as 9:1.6:3:7; costal cell without setae dorsally, ventrally with 2 or 3 rows in distal  $\frac{1}{2}$ ; basal cell and cubital veins without setae; wing surface beyond basal vein almost completely covered with setae ex-

cept small bare area proximal to parastigma; petiolate segment of stigmal vein about  $0.66\times$  stigmal height, stigma  $1.5\times$  as high as wide (Fig. 21), surrounded by narrow translucent brown band, ventral margin convex, uncus about  $1.5\times$  as long as wide. Metasoma: Laterally compressed; ratio of mesosoma:metasoma:hypopygium as 5:5:4.

*Male*.—Unknown.

*Types*.—Holotype ♀ with following data: Papua New Guinea, Madang Prov., Nokopo, Aug. 1987, 2000 m., D. Sands, ex fruit *Pandanus* (deposited in ANIC); 3 ♀ paratypes, same data as holotype (2 paratypes ANIC, 1 paratype USNM).

*Etymology*.—The name is derived from the Greek “*xestos*” meaning polished, in reference to the mesosoma of this species.

*Distribution*.—Known only from Papua New Guinea.

*Host*.—The type specimens were reared from seeds of *Pandanus*.

*Discussion*.—This species is unique among known *Bootania* based on the following character states: The coloration is entirely black in dorsal aspect (other species are essentially all yellow or patterned mixtures of black, orange, yellow, and/or white); the propodeal spiracle (Fig. 31, inset) is set within an elevated, chamberlike structure encircled by a translucent rim (other species have no such chamber or encircling rim, e.g., Fig. 33, inset); the propodeum (Fig. 31) has a flat, elevated median section with distinct, well-defined carinae separated by flat, shagreened spaces (other species, except *B. pilicornis*, have a poorly defined median section at best, with irregular carinae forming pits, as in Fig. 33), or in some cases a well-defined circular area (Fig. 32); the toruli (Fig. 25) are separated by a distance at least their own short diameter apart (other species have the distance distinctly less than a diameter—generally about half, as in Fig. 23, 26–28); the scrobal basin (Fig. 25) is wider than the upper face between the depression and the inner eye

margin (other species have this distance less than the scrobal depression, as in Fig. 23, 24, 26–28); and females have flagellomeres (Fig. 39) with erect setae that are longer than the width of the segment (other species usually have appressed setae that are shorter than the width of the segment, as in Fig. 40, 41), and the longitudinal sensilla of the flagellomeres are produced as curved, flattened projections (Fig. 39) (other species usually have longitudinal setae that are appressed to the flagellomere as in Figs. 40–42). With respect to the erect setae, females of *B. xestos* are somewhat like males of other known species.

*Boottania xestos* has three character states that are similar to ones found in *B. pilicornis*. In *B. xestos* the mesosoma is essentially smooth and polished with the exception of a few obscure transverse wrinkles on the pronotum (in *B. pilicornis* the mesosoma is smooth but with obscure wrinkles on the pronotum and weak carinae on the mesoscutum). In *B. xestos* and *B. pilicornis* the mesosoma is flattened so that the pronotum is nearly in the same plane as the propodeum. These are the only two species that are pronouncedly flattened. Finally in *B. xestos* and *B. pilicornis* the median area of the propodeum appears elevated and separated from the postspiracular groove by a carina, but the two differ, however, in the spiracle as stated above.

#### ACKNOWLEDGMENTS

We thank the following curators for the loan of material: John Noyes, The Natural History Museum, London; Jo Cardale, CSIRO, Canberra; and Frank Koch, Zoologisches Museum, Humboldt-Universität, Berlin. We also thank Chris Burwell, Queensland Museum, Brisbane, and Jo Cardale, CSIRO, for facilitating the work of EEG at those museums. Additionally, we thank the following for reviewing the manuscript: Michael Gates, David Smith, Manya Stoetzel (all Systematic Entomology Laboratory), and John Noyes, The Natural History Museum; and Terry Nuhn (Systematic Entomology Laboratory) for preparing the habitus figure.

#### LITERATURE CITED

- Ashmead, W. H. 1904. Descriptions of new Hymenoptera from Japan. *Journal of the New York Entomological Society* 12: 65–84.
- Bouček, Z. 1988. *Australasian Chalcidoidea (Hymenoptera): A biosystematic revision of genera of fourteen families, with a reclassification of species*. Wallingford, UK: C.A.B. International, 832 pp.
- California Rare Fruit Growers. 1989. *RFG Publications 1969–1989 Index—P*; <http://crfg.org/fg/\xref/\xref-p.html#pandanus>.
- Cameron, P. 1905. On the phytophagous and parasitic Hymenoptera collected by Mr. E. Ernest Green in Ceylon. *Spolia Zeylanica* 3: 67–97 (First Paper), 98–143 (Second Paper) [Plates A and B precede page 143 on unnumbered pages.]
- Cameron, P. 1909. On two new genera (one representing a new tribe) from Borneo. *Entomologist* 42: 209–211.
- Dahms, E. C. 1984. A checklist of the types of Australian Hymenoptera described by Alexandre Arsené Girault: III. Chalcidoidea species F–M with advisory notes. *Memoirs of the Queensland Museum* 21: 579–842.
- Dalla Torre, C. G. de. 1897. Zur Nomenclatur der Chalcididen-Genera. *Wiener Entomologische Zeitung* 16: 83–88.
- Dalla Torre, C. G. de. 1898. *Catalogus Hymenopterorum hucusque descriptorum systematicus. V. Chalcididae et Proctotrupidae*. Leipzig: 598 pp.
- Girault, A. A. 1928. A prodigious discourse on wild animals. Privately printed. 3 pp.
- Girault, A. A. 1938. A giant from New Guinea. *Verhandlungen VII. Internationaler Kongress für Entomologie* 1: 147–150.
- Grissell, E. E. 1999. An annotated catalog of world Megastigminae (Hymenoptera: Chalcidoidea: Torymidae). *Contributions of the American Entomological Institute* 31 (4): 1–92.
- Hübner, J. 1819 (1816–1826). *Verzeichniß bekannter Schmettlinge*. Augsburg, 431 pp. (+ 81 pg., index).
- Kamijo, K. 1962. A revision of the species of the Megastigminae occurring in Japan (Hymenoptera: Chalcidoidea) (Taxonomic studies on the Torymidae of Japan, I). *Insecta Matsumurana* 25: 18–40.
- Kamijo, K. 1981. Description of the male and other notes on *Macrodasyceras hirsutum* (Hymenoptera: Torymidae). *Akita* 38: 1–4.
- Milliron, H. E. 1949. Taxonomic and biological investigations in the genus *Megastigmus* with particular reference to the taxonomy of the Nearctic species (Hymenoptera: Chalcidoidea: Callimomidae). *American Midland Naturalist* 41: 257–420.
- Milliron, H. E. 1950. Descriptions of some species of the genus *Pulvilligera* Strand from the south and southwest Pacific. *Pacific Science* 4: 346–354.
- Narendran, T. C. 1994. *Torymidae and Eurytomidae of*

- the Indian subcontinent*. Published by the author, 500 pp.
- Riek, E. 1970. Chalcidoidea, pp. 913–924. In CSIRO ed., *The Insects of Australia*. Melbourne University Press, Carlton, Victoria. 1029 pp.
- Rye, E. C. 1874. Insecta. Hymenoptera. *Zoological Record* 11: 343–368.
- Smith, J. C. 1855. *Harper's Statistical Gazetteer of the World*. Harper & Brothers, New York, NY. 1952 pp.
- Stone, B. C., K.-L. Huynh, and H.-H. Poppendieck. 1998. Pandanaceae, pp. 397–404. In, K. Kubitzki, ed. *The families and genera of vascular plants. Vol. III, Flowering Plants*. Springer-Verlag, Berlin, 478 pp.
- Strand, E. 1911. Eine neue Chalcididen-Gattung und Art, die zugleich den Typus einer neuen Tribus bildet. *Entomologische Rundschau* 28: 58–59.
- USDA, NRCS 1999. *The PLANTS database*; <http://plants.usda.gov/plants>.
- Walker, F. 1862. Notes on Chalcidites, and characters of undescribed species. *Transactions of the Royal Entomological Society of London* (3) 1: 345–397.
- Westwood, J. O. 1874. *Thesaurus Entomologicus Oxoniensis*. Oxford: Clarendon Press, 205 pp.

## Phylogeny of the Genera of Ticoplinae (Hymenoptera: Mutillidae)

ANDREW MITCHELL AND DENIS J. BROTHERS

School of Botany and Zoology, University of Natal Pietermaritzburg, Private Bag X01, Scottsville, 3209 South Africa (AM now: School of Molecular and Cellular Biosciences); AM email: mitchella@nu.ac.za DJB email: brothers@nu.ac.za

---

*Abstract.*—The subfamily Ticoplinae Nagy is one of the more basal taxa in Mutillidae. Cladistic analyses using 21 characters have demonstrated that recognition of two tribes is supported. Ticoplini Nagy includes *Nanomutilla* André (= *Ticopla* Nagy *syn. nov.*) and *Arcotilla* Bischoff; Smicromyrmillini Argaman includes *Smicromyrmilla* Suárez (and possibly *Cameronilla* Lelej and Krombein, *Eosmicromyrmilla* Lelej and Krombein, and *Hindustauilla* Lelej and Krombein, should these be considered valid). The subfamily and tribes are reviewed and characterized, a key to tribes and genera is provided, and both sexes of typical members of the three main genera are illustrated. *Nanomutilla nadae* Argaman 1988 is selected as the correct spelling for the species also spelled *N. nada* in its original description, and *Arcotilla ferruginea* Mitchell and Brothers 1998 for the species also spelled *Arcotilla ferruginata* in its original description.

---

Ticoplinae Nagy 1970 is one of the relatively basal subfamilies of Mutillidae, as shown by Brothers (1975, 1999) (Fig. 1) and by Lelej and Nemkov (1997) whose analyses differed from Brothers' in several respects. It was established as a subfamily of Nagy's Heterogynidae (properly Heterogynidae; International Commission on Zoological Nomenclature 1987), to accommodate the genus *Ticopla* Nagy 1970, known only from male specimens. Brothers (1975) transferred Ticoplinae to Mutillidae, and Day (1984) placed *Heterogyn* Nagy in Sphecidae s.l.; it is now considered to comprise a distinct family, Heterogynidae (Brothers 1999, Melo 1999). The genera placed in Ticoplinae by Brothers (1975) were *Arcotilla* Bischoff 1920, *Nanomutilla* André 1900, *Smicromyrmilla* Suárez 1965 and *Ticopla*. Independently, Suárez (1975) proposed a new subfamily, Nanomutillinae, to contain *Nanomutilla*, and placed *Smicromyrmilla* in Myrmillinae but he did not realise that *Ticopla* or *Arcotilla* were of relevance. Brothers' (1975) study settled much of the controversy over the classification of these genera by showing

that they belong in a single subfamily, the valid name of which is Ticoplinae (and would remain so even if *Ticopla* were considered a junior synonym of *Nanomutilla*; International Commission on Zoological Nomenclature 1999: Article 40.1). He also concluded that the relationships amongst the component genera were such as to preclude the recognition of tribal divisions. However, Argaman (1988) proposed such divisions: Ticoplini, including *Ticopla* and *Nanomutilla*, which he considered distinct, and Smicromyrmillini, including *Smicromyrmilla*. He did not examine *Arcotilla*.

The cladistic study presented here elucidates the phylogeny of the genera of Ticoplinae, enabling objective assessment of Argaman's tribal divisions. The morphological terms used are those of Gauld and Bolton (1988). Specimens examined are in the collection of one of the authors (DJB) or were borrowed from numerous institutions (particularly the Natural History Museum (London) and Muséum National d'Histoire Naturelle (Paris)) over many years.

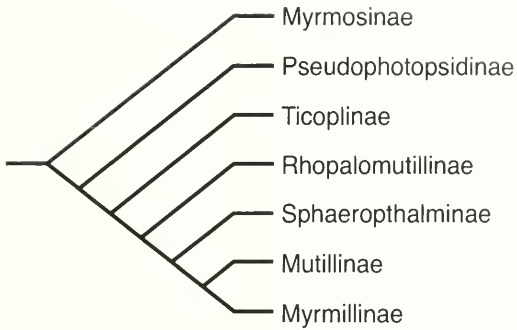

Fig. 1. Phylogeny of subfamilies of Mutillidae (simplified from Brothers 1975, 1999).

## GENERA OF TICOPLINAE

### *Nanomutilla* André

(Figs. 2–9)

*Mutilla* (*Nanomutilla*) André 1900: 130.

Type species: *Mutilla vaucheri* Tournier 1895, Morocco, by subsequent designation of Ashmead (1903).

*Ticopla* Nagy 1970: 85.

Type species: *Ticopla yoca* Nagy 1970, Jordan, by original designation. **Syn. nov.**

The first description of *Nanomutilla* appeared in a key to subgenera of *Mutilla* published in April 1900, without any mention of included species. Later, in the same work, André (1901b: 223) presented a formal description based on a single species known from females only (*Mutilla vaucheri*) but also provided a description of the male in a footnote (p. 224), based on a second species supposedly known from both sexes (*Mutilla microsoma*) which he had recently described; it must thus be concluded that there were two originally-included species, although subsequent authors have considered *Nanomutilla* to have been a monotypic genus at establishment. André (1901a) described both sexes of *Mutilla* (*Nanomutilla*) *microsoma* from South Africa, being under the impression that the male and female specimens had been collected in the same area, Willowmore (“... j’ai trouvé une autre espèce du même sous-genre ... accompagnée d’un mâle rencontré dans les mêmes parages”). This, along

with their similarity in size, convinced him that the two specimens were conspecific, despite the fact that they were not captured *in copula*. We have examined the type series of *M. (N.) microsoma* in the Transvaal Museum and found that the female specimen was actually collected at Bothaville, in the Free State, while the male was collected near Willowmore, in the Eastern Cape, approximately 700 km away. They are not conspecific, nor even congeneric; Nonveiller (1973) concluded that the male really belongs in *Smicromyrmilla*. To add to the confusion, Bischoff (1921) described six new species of *Nanomutilla* without examining the type species; all of his new species would later be recognised as belonging in *Smicromyrmilla* (Nonveiller 1973). Not surprisingly, Arnold (1946, 1960) made the same error in describing another two species. Nonveiller (1973) transferred to *Smicromyrmilla* all species of *Nanomutilla*, except for *N. vaucheri* and the female of *N. microsoma*, and delimited both genera, although he had also not examined the type specimen(s) of *N. microsoma*. We confirm Nonveiller’s conclusions as correct. Argaman (1988) described a third species, *N. nadae* from Spain, again known only from female specimens. (Although the name is mostly spelled “*nada*” in that paper, it is “*nadae*” in the key; there is a statement that the species is named after Mrs Nonveiller, using her nickname [which is Nada, DJB pers. obs.], so the feminine genitive form is preferable, and the commoner spelling is probably an inadvertent error.)

Many statements by other authors referring to *Nanomutilla* have been based on a presumption that they apply to the type species, *N. vaucheri*. It is now clear to us, however, that the specimens identified and illustrated as *N. vaucheri* by Nonveiller (1973), Argaman (1988), and possibly Suárez (1975), were misidentified, although they were also collected in Morocco (the type locality of *N. vaucheri* being Tangier). When compared with the origi-

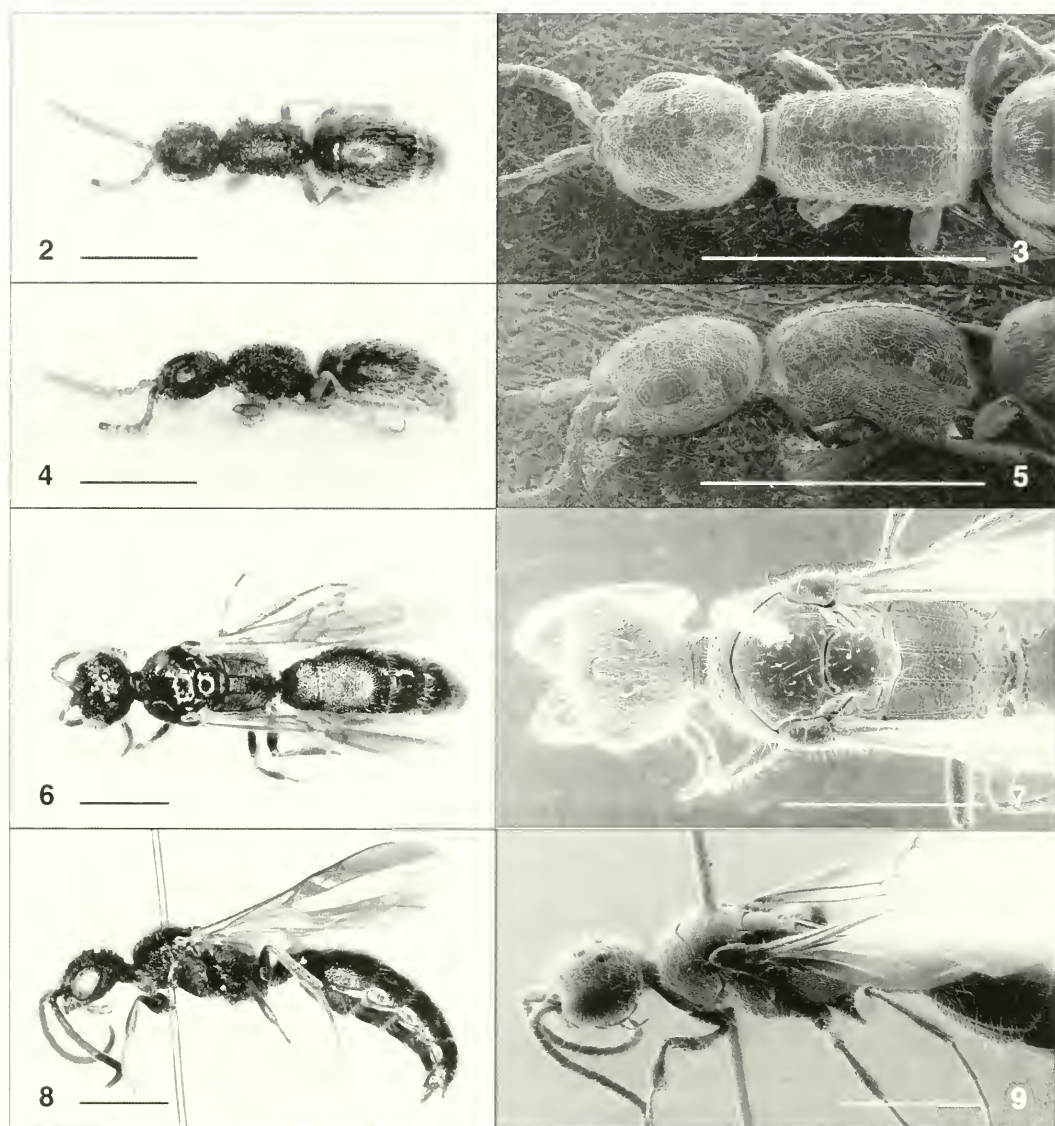

Figs. 2-9. *Nanomutilla* spp., dorsal and lateral views. 2-5, *N. vaucheri* (Tournier), ♀, length = 2.0 mm (Gibraltar, compared with holotype). 6-9, *N. sp.*, ♂, length = 4.4 mm (Zimbabwe). Scales = 1.0 mm.

nal description (Tournier 1895) and the fuller description and illustration by André (1901b), some discrepancies are obvious. Both Tournier and André referred to a median longitudinal carina on the mesosoma (this is shown in André's illustration as ending in a fine tooth posteriorly) and also stated (and illustrated) that the mesosoma was twice as long as wide. The illustrations given by Nonveiller (1973)

and Argaman (1988) show the mesosoma as much less slender, without a complete longitudinal carina and without a median posterior tooth; Suárez (1975) expressed puzzlement at the lack of such a carina in specimens he identified as *N. vaucheri* but provided no illustrations. One of us (DJB) has examined the holotype of *N. vaucheri* (collected at Tangier by Vaucher, with Tournier's determination label referring to

the publication of the name, labelled as from the Tournier Collection and housed in the Geneva Museum). Unfortunately, it has been glued dorsal-side down to a card so that the dorsal surface of the mesosoma is almost entirely obscured. There is, however, a clearly conspecific specimen in the same collection, also collected at Tangier (in 1896), which is essentially identical to the holotype (although with the tibiae very slightly paler); the mesosomal dorsal surface is clearly visible and shows an almost complete very fine median longitudinal carina ending in a very small posterior tubercle, and the mesosoma is relatively more elongate than in the specimens illustrated by Nonveiller (1973) and Argaman (1988). Another specimen, from Gibraltar and housed in the Natural History Museum, London (illustrated here, Figs. 2–5), is also clearly conspecific although the appendages are slightly paler than in the holotype; it has lost the scattered long erect setae on the mesosoma and most of the decumbent pubescence, but shows the carina and tubercle more clearly as a result. The carina is extremely fine and somewhat irregular, normally concealed under fairly dense diagonally oriented decumbent pubescence that gives the appearance of a mid-dorsal line in unworn specimens, and even when visible needs careful illumination; Suárez (1975) may thus have overlooked it, although he did comment on the pubescent line. Both species of *Nanomitilla* illustrated and discussed by Argaman (1988) are different from the true *N. vaucheri* in all of the features listed by him as important in species differentiation, and, since the specimen he considered to be *N. vaucheri* was obtained from Nonveiller, it is clear that Nonveiller (1973) also misidentified the species. (Of four specimens now in the Paris Museum identified as *N. vaucheri* by André, only one (from Gibraltar, obtained from Saunders and thus almost certainly collected at the same time as the specimen in the London Museum) is correctly identified; the

others, one from Algeria and two from Syria, represent two different species.)

*Ticopla* was described for two new species collected in the Jordan region and known only from males (Nagy 1970). Brothers (1975) suggested that one of these may be the male of *N. vaucheri*, supposedly known from the same area but only from females (based on specimens so identified by André, see above). Argaman (= Nagy) (1988) countered this by describing females of both species of *Ticopla*. Nonetheless, he stated that “the resemblance between *Nanomitilla* and *Ticopla* females is so remarkable, and the difference so delicate, [that it is] entirely understandable” that André had identified a specimen from Syria (that Argaman called a *Ticopla*) as *N. vaucheri*; i.e., Argaman (1988) stated that these genera are so similar as to be easily confused.

We have examined five specimens (three females from Syria and two males from Amman, Jordan) that are unquestionably *Ticopla* based on Argaman's (1988) criteria, and find no consistent differences between them and female specimens of 6 further species from Gibraltar and Morocco (*N. vaucheri*) and southern Africa (including *N. microsoma*), and males of 17 species from Kenya and Angola to southern Africa. The differences in the sculpturing of the mesosomal dorsum of both sexes, the main character used by Argaman in distinguishing these two genera, are by no means as distinct as he supposed, since intermediate forms occur. Other differences given by Argaman, such as the shape of the flagellomeres, depend on the angle at which the specimen is viewed. Loss of the second submarginal cell (1S), thought characteristic of *Ticopla* by Brothers (1975), is also not significant since different degrees of reduction in wing venation are evident. We thus have no hesitation in regarding *Nanomitilla* and *Ticopla* as synonymous. Lelej and Krombein (2001) also regarded *Ticopla* as a synonym of *Nanomitilla*, implying that they

were following Argaman (1988) in this (which was incorrect since Argaman clearly stated that he considered them distinct, see above); it is probable that they were really following the suggestion made by Mitchell and Brothers (1998). The genus has an extensive distribution in the Afrotropical and southern Palaearctic (Iberian peninsula, Morocco, Algeria, Levant) Regions, most species being as yet undescribed.

***Arcotilla* Bischoff**  
(Figs. 10–17)

*Arcotilla* Bischoff 1920: 25, 174.

Type species: *Arcotilla arcolata* Bischoff 1920, Transvaal, by original designation.

This genus was based on the type species and *A. marshalli* (André 1903). It is the smallest genus in the subfamily in terms of species numbers, and has been revised by Mitchell and Brothers (1998). It comprises eight species known from males and two known from females, all from southern Africa. (It should be noted that the correct spelling of the name for the new species referred to as *A. ferruginea* (in the text) and *A. ferruginata* (in a figure caption) by Mitchell and Brothers (1998) should be *A. ferruginea*; the *lapsus* is regretted.)

***Smicromyrmilla* Suárez**  
(Figs. 18–25)

*Smicromyrmilla* Suárez 1965: 570.

Type species: *Mutilla ariasi* André 1896, Spain, by original designation.

This genus was described for a single species (and single female specimen), although a second species from Spain, *Smicromyrmilla miranda* Nonveiller and Gros 1996, based on a single male specimen, has since been described; these are the only specimens recorded from that country, and may thus be conspecific. Nevertheless, many other species of *Smicromyrmilla* have been described and even more await description; they were being revised

by Nonveiller (pers. comm.) before his recent death. The genus exhibits considerable morphological variation (it is the only ticolpine genus in which brachypterous and apterous males are known) and is widely distributed throughout the Afrotropical, southern Palaearctic (Spain, North Africa) and Oriental Regions.

After this paper had been accepted for publication, Lelej and Krombein (2001) described three new genera of *Smicromyrmillini* (*Cameronilla*, *Eosmicromyrmilla* and *Hindustanilla*) from the Oriental Region and provided a key for their recognition. For our study we had examined an apterous male of one of these genera (*Hindustanilla*) and considered it to be a *Smicromyrmilla*, although a somewhat anomalous one. We had also examined several Afrotropical species with characteristics different from those Lelej and Krombein considered limited to *Smicromyrmilla*, but again did not consider them as generically distinct. We recognised that *Smicromyrmilla*, as we conceived it, was quite variable, but saw independent variation in several of the characters used by Lelej and Krombein (2001) to distinguish their new genera, with many intermediates making recognition of new putative genera questionable. For this reason, we do not distinguish between *Smicromyrmilla* and the new genera proposed by Lelej and Krombein (2001), but do not wish to synonymise them formally. As far as we can ascertain, those genera agree with *Smicromyrmilla* in all of the characters we have used in this analysis. (We also suspect, however, that *Cameronilla* may not actually be a ticolpine. Lelej and Krombein based their conclusions entirely on the rather inadequate original description and figure of the female of *Mutilla oedipus* Cameron 1897 in placing it in this subfamily, citing the presence of a median and lateral spines on the propodeum. Those characteristics would not preclude its placement in Myrmillinae, however,

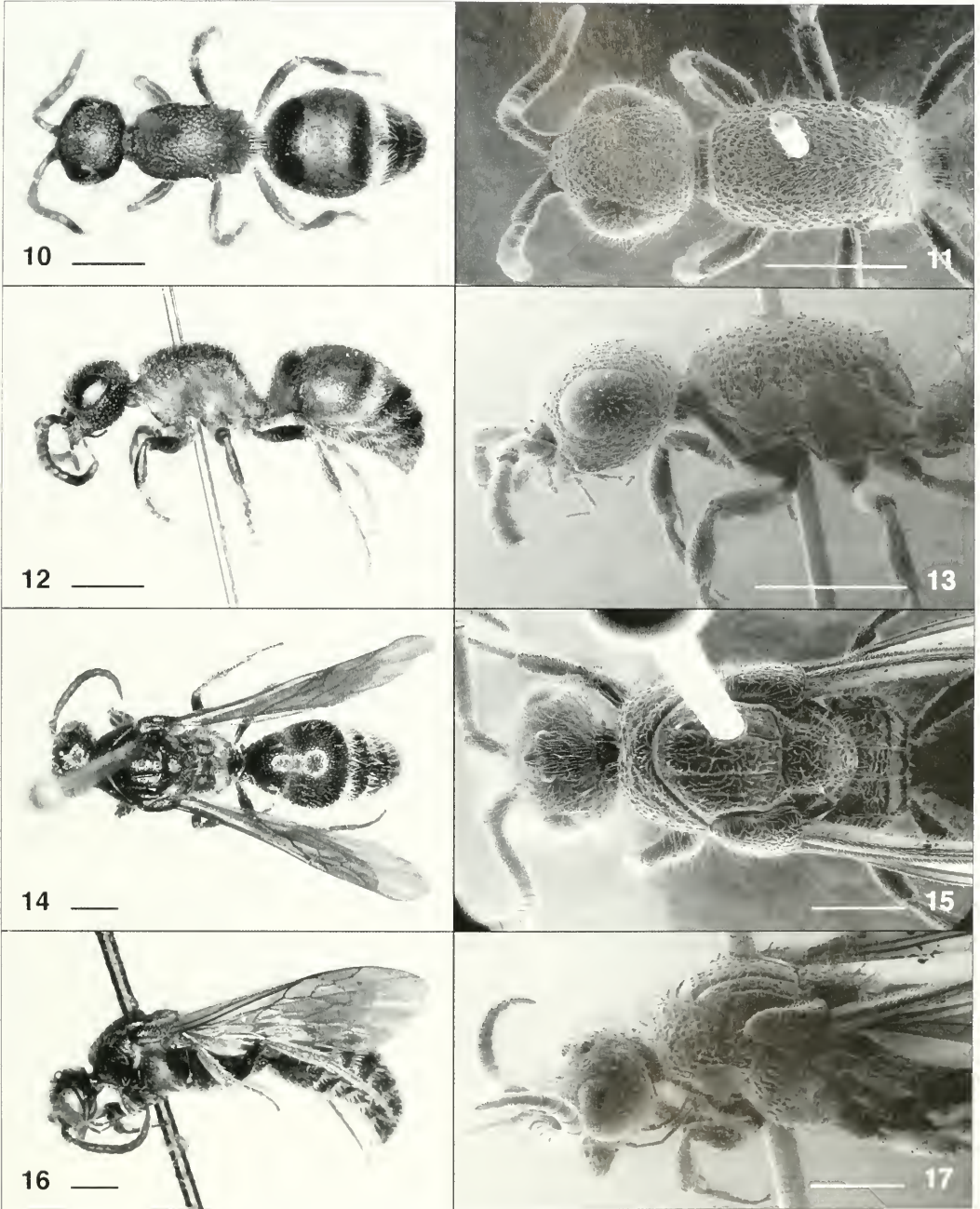

Figs. 10–17. *Acrotilla* spp. 10–13, *A. ferruginea* Mitchell and Brothers, ♀, length = 4.9 mm (paratype, South Africa, KwaZulu-Natal). 14, 16, *A. marshalli* (André), ♂, length = 7.7 mm (holotype, South Africa, Northern Province). 15, 17, *A. vulgaris* Mitchell and Brothers, ♂, length = 8.9 mm (paratype, South Africa, Eastern Cape). Scales = 1.0 mm.

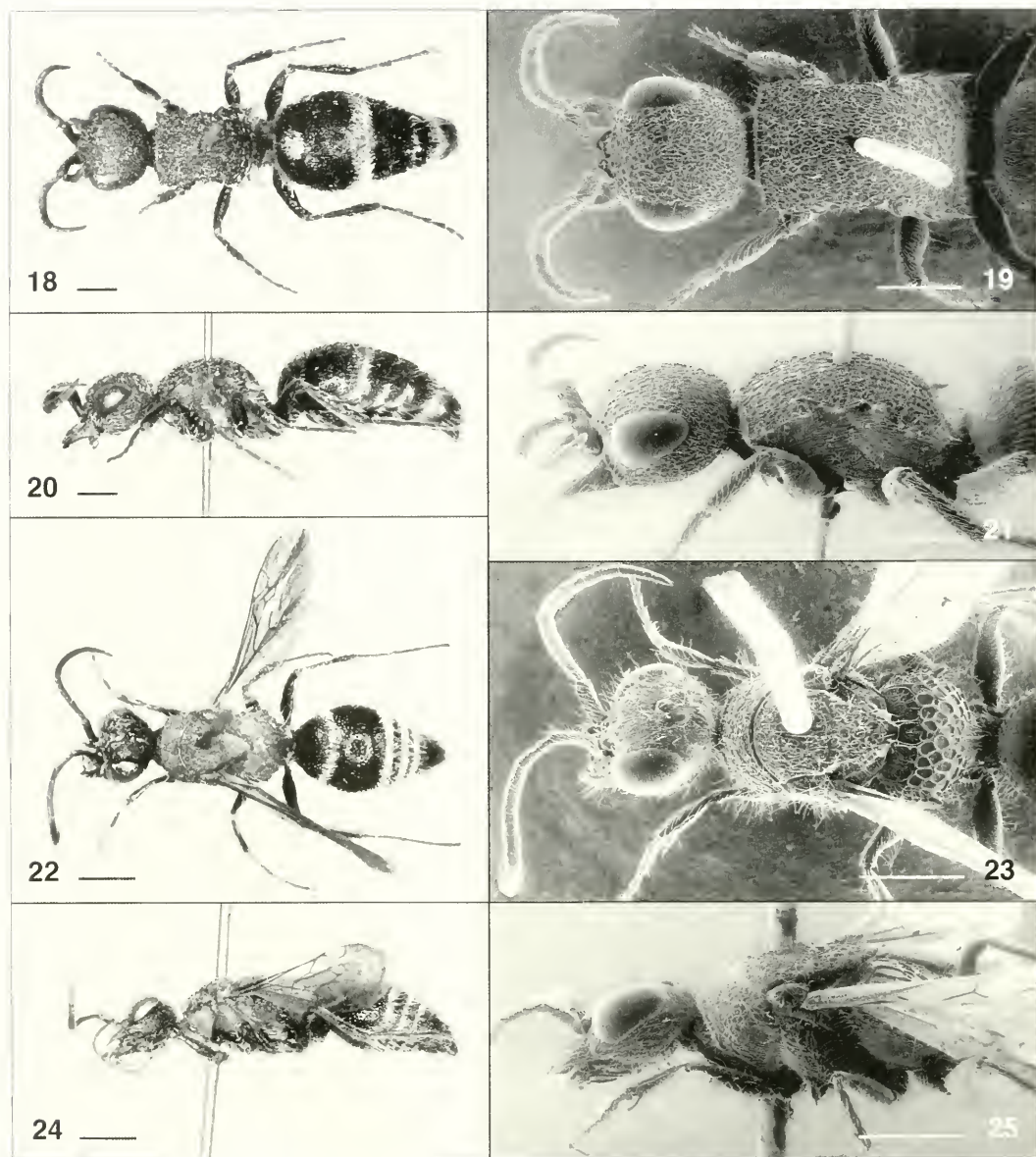

Figs. 18–25. *Smicromyrmylla* spp. 18–21, *S.* sp., ♀, length = 8.4 mm (South Africa, Mpumalanga). 22–25, *S.* sp., ♂, length = 6.5 mm (South Africa, Gauteng). Scales = 1.0 mm.

which placement is also suggested by its enlarged quadrate head.)

#### MATERIALS AND METHODS

Specimens of all available species of Ticoptlinae (*Arcotilla*: 8 species based on males, 2 on females; *Nanomutilla*: 18 on males, 8 on females; *Smicromyrmylla*: 21 on

males, 8 on females) were surveyed. Of the more than 40 morphological characters examined, 21 (Appendix 1) had appropriate levels of variation (i.e. they were found to be variable among but not within genera) and were used in cladistic analyses. Character polarity was established by out-group comparison. When there was vari-

Table 1. Data matrix for analysis of genera of Ticoplinae using 21 characters of Appendix 1.

	1	2	3	4	5	6	7	8	9	10	11	12	13	14	15	16	17	18	19	20	21
Ancestor	0	0	0	0	0	0	0	0	0	0	0	0	0	0	0	0	0	0	0	0	0
<i>Areotilla</i>	0	0	0	1	0	1	1	1	0	1	1	0	1	0	1	1	0	1	1	0	0
<i>Nanomutilla</i>	0	0	0	1	0	0	0	0	0	0	2	1	1	0	1	0	1	1	1	0	0
<i>Smicromyrmilla</i>	1	1	1	0	1	0	1	0	1	1	0	0	0	1	0	1	0	2	0	1	1

ation among out-group taxa, *ad hoc* parsimony analysis was used to determine the plesiomorphic state; this is discussed, where applicable, below. Maximum-parsimony analysis was carried out using the software package Hennig86 version 1.5 (Farris 1988) (command *ie\**), and analysis using implied weights (Goloboff 1993) was done using *Pee-Wee* version 2.1 (Goloboff 1994) (commands *hold\* search=hold/20 mult\*15*). A hypothetical ancestral taxon was included, with all character states coded "0", to root the tree. Trees were analysed using *Clados* version 1.6.1 (Nixon 1994).

Out-group selection presented some difficulties, as the sister group of the Ticoplinae consists of the Rhopalomutillinae, Sphaerophthalminae, Mutillinae and Myrmillinae (see Fig. 1), i.e., most of the diversity of the family. In addition, these subfamilies all tend to show a greater proportion of apomorphic characteristics than does the Ticoplinae, and their usefulness is therefore lessened, particularly in the case of the Rhopalomutillinae, which has a comparatively large proportion of derived characteristics. We expected that

more accurate determination of character polarity would be obtained by including more relatively basal groups in the out group; thus the out group comprised four genera: *Myrmosa* Latreille (about 5 species examined) and *Myrmosula* Bradley (about 2 species) (both Myrmosinae), *Pseudophotopsis* André (about 10 species) (Pseudophotopsidinae) and *Dasylabris* Radoszkowski (about 15 species) (Sphaerophthalminae). The plesiomorphic state is that state found in all four out-group genera, unless otherwise stated. Note that *Pseudophotopsis* also has a large proportion of apomorphic character states and quite often has the derived state of a character when the other three out-group genera have the plesiomorphic state.

## RESULTS

Table 1 shows the distribution of character states among the genera of Ticoplinae. The single most-parsimonious tree found (Fig. 26) has *Areotilla* and *Nanomutilla* as sister groups; the same tree was found using implied weighting. This tree has length = 26 steps, consistency index (CI) = 0.88 and retention index (RI) =

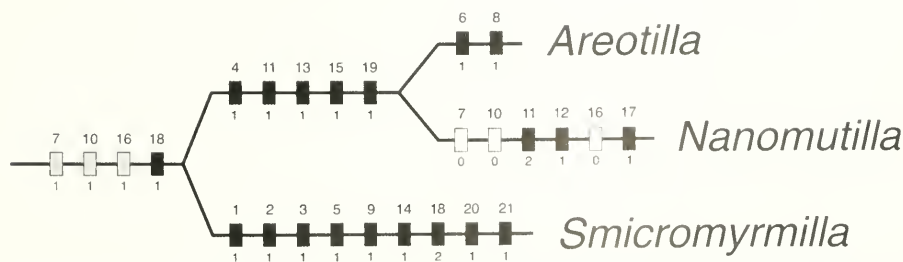

Fig. 26. Single most-parsimonious cladogram of genera of Ticoplinae (length 26, consistency index 0.88, retention index 0.62). Character numbers above, states below hash marks. Hash-mark shading: black = unique derivation, grey = convergent derivation, white = reversal.

0.62. Under fast (accelerated transformation) optimisation, the 23 derived states comprise 14 autapomorphies, 5 unique synapomorphies for *Areotilla* and *Nanomutilla*, 1 unique synapomorphy for all three genera, and 3 homoplasies (characters 7M, 10M and 16M). An alternative tree with *Areotilla* and *Smicromyrmillina* as sister groups (supported by 3 synapomorphies) is two steps longer and has a much lower RI (length = 28, CI = 0.82, RI = 0.37); the other alternative tree with *Nanomutilla* and *Smicromyrmillina* as sister groups is not supported by any synapomorphies and is even longer (length = 31, CI = 0.74, RI = 0.00).

From the results, it is evident that *Areotilla* and *Nanomutilla* are the most closely related cladistically, and are distinct from *Smicromyrmillina* in several respects. The degree of difference seen between the two groups is similar to, if not greater than, that between the tribes of Sphaerophthalminae or Mutillinae (Brothers 1975) or those of Myrmosinae (Brothers 1999). This contrasts with the opinion of Brothers (1975) who had seen far fewer representatives of these genera and who felt that there were no marked groupings between them. We thus consider that recognition of two tribes, as proposed by Argaman (1988), is warranted despite the fact that both contain relatively few species when compared with most other tribes of Mutillidae.

#### CHARACTERISTICS OF SUBFAMILY AND TRIBES

Previous descriptions or diagnoses of the subfamily and tribes, such as those by Brothers (1975, 1993), Suárez (1975) and Argaman (1988), are incomplete or inaccurate, mainly because those authors had access to far fewer species than we were able to examine. The following descriptions are followed by comments indicating differences from previous attempts.

**Ticoplinae** Nagy 1970 (= *Nanomutillinae* Suárez 1975).—No felt line on second

metasomal tergum. Macropterous males with fully articulating meso-metapleural suture (i.e., no ventral bridge-like fusion between meso- and metapleuron), posteriorly convex mesopleural margin, petiolate second submarginal cell in the forewing, and volsella lacking digitus (i.e., only cuspis present). Females and microppterous/apterous males with mesosoma widest posteriorly (seldom with sides more or less parallel) with one or more weak to strong teeth or spines at posterolateral angle, posterolateral margin of pronotum indistinguishably fused with mesopleuron (except in males with pronotum articulating with mesothorax), and distance from humeral angle to pronotal spiracle at least as long as that between pronotal and propodeal spiracles (except in males with articulating pronotum where it may be shorter).

**Ticoplini** Nagy 1970 (= *Nanomutillini* Suárez 1975).—Eye strongly pubescent; antennal tubercles closely approximated basally but separate, not joined by a straight transverse ridge, scarcely protruding; pronotum smoothly and evenly convex over anterior declivity, without a transverse carina; propodeum with disc and declivity distinct; second metasomal sternum without felt line. Males with notauli usually distinct (often faint and sometimes absent in *Nanomutilla*); scutellum not apically produced; propodeum with three or five large fields covering entire surface of disc and defined by well developed carinae; metasomal sternum 2 with a short median longitudinal carina basally; penis valve  $> 0.75\times$  as long as paramere. Females with at most one short spine on posterolateral angle of propodeum at apex of lateral oblique transverse carina; 'auricle' at base of first metasomal tergum merely a small rounded protuberance; no defined pygidial area.

**Smicromyrmillini** Argaman 1988.—Eye pubescence absent although pores and/or very sparse minute setae may be present; antennal tubercles fused basally, joined by

a small straight transverse ridge, distinctly protruding; pronotal dorsum sharply separated from anterior declivity, with junction angular and marked by a transverse carina; propodeum with disc and declivity evenly merging, not distinct; second metasomal sternum with well developed lateral felt line. Macropterous males lacking notauli; scutellum apically produced over metanotum; propodeum with three poorly defined anterior fields and many reticulations forming mini fields over posterior half; metasomal sternum 2 lacking median longitudinal carina; penis valve < 0.60× as long as paramere. Females and microp-terous/apterous males with at least two spines on posterolateral angle of propo-deum, lacking lateral oblique carina to base of spine; ‘auricle’ at base of first me-tasomal tergum forming a strong lamel-late or spinose protuberance; glabrous py-gidial area well defined.

Suárez (1975) included only *Nanomutilla* (females) in his subfamily Nanomutillinae. Various of the features that he high-lighted as being characteristic of the group (as compared with *Smicromyrmilla* which he placed in the Myrmillinae) are thus re-stricted to that genus, and in particular to a species which he considered to be *N. vaucheri*. Non-differentiated pubescence on the body was thought characteristic, as compared with the varied pubescence generally forming patterns in other Mutillidae; although this is particularly true of *Nanomutilla*, it is approached in *Areotilla* but is not particularly significant since it occurs elsewhere in the Mutillidae also. The peculiar ‘bethyloid’ or ‘proctotrupoid’ body form was also highlighted, but this is not true of *Areotilla*.

Argaman (1988) also included only *Nanomutilla* (and ‘*Ticopla*’), but both sexes, in the Ticoplini. He thought that the flagel-lomeres were different in shape and struc-ture from those in *Smicromyrmillini*, that the pronotum (in the female) differed in the number of lateral pits and that the de-gree of production of the apex of the pro-podeum at the articulation with the me-tasoma differed. We have found that fla-gellomere shape varies across both tribes and also according to viewpoint, that the development of pits on the pronotum varies considerably and that the produc-tion of the propodeal lobe also varies and is not significantly different from the con-dition in most other Mutillidae. Argaman remarked on the fact that the second me-tasomal tergum is longer than wide in fe-male Ticoplini, but this is true only of some *Nanomutilla* and not of *Areotilla*. For male Ticoplini, Argaman noted the pre-sence of a single complete ridge on the scape, but this is true of *Nanomutilla* only (see our character 7, below).

Neither Suárez (1975) nor Argaman (1988) mentioned the pubescence of the eye in female Ticoplini, presumably be-cause it is difficult to see in *Nanomutilla* specimens, which are very small. Both au-thors noted the absence of ‘auricles’ (Brothers 1975) at the base of the metasoma, but they are actually present although inconspicuous.

For the *Smicromyrmillini*, Argaman (1988) made much of the carinate anterior margin of the mesoscutum in the male, considering this a unique character in Hy-menoptera; such a carina is certainly pre-sent in some species of *Smicromyrmilla* but many other species have no trace of it.

---

KEY TO TRIBES AND GENERA OF TICOPLINAE

[Note: We consider *Eosmicromyrmilla* and *Hindustanilla* doubtfully distinct from *Smicromyrmilla*; *Cameronilla* is probably misplaced in Ticoplinae, see above, and is therefore omitted from this key.]

- 1 (a) Wings well developed (male) ..... 2
- (b) Wings absent or rudimentary (female, rarely male) ..... 4

- 2 (a) Eye pubescence distinct; scutellum apex not overhanging metanotum; propodeal disc covered by 3 or 5 large fields each surrounded by well developed carinae; metasomal sternum 2 without felt line (Ticoplini) . . . . . 3  
 (b) Eye pubescence absent; scutellum apex produced and overhanging metanotum; propodeum with 3 very weakly defined anterior fields and many reticulations forming mini fields over posterior half; metasomal sternum 2 with well developed lateral felt line (Smicromyrmillini) . . . *Smicromyrmilla* (including *Eosmicromyrmilla* and *Hindustanilla*)
- 3 (a) Tegula elongate and reniform,  $> 0.75\times$  as long as mesoscutum; propodeal disc with 5 fields; paramere apex very strongly curved ventrally . . . . . *Areotilla*  
 (b) Tegula oval,  $< 0.60\times$  as long as mesoscutum; propodeal disc with 3 fields; paramere almost straight . . . . . *Nanomutilla*
- 4 (a) Eye pubescence distinct; metasomal sternum 2 without felt line; propodeum with disc and declivity distinct, separated laterally by an oblique transverse carina ending in a single small posterolateral tooth; no distinct pygidial area (Ticoplini) . . . . . 5  
 (b) Eye pubescence absent; metasomal sternum 2 with lateral felt line; propodeum with disc and declivity smoothly merging, without any lateral transverse carinae and with 2 or more posterolateral teeth or spines; female with distinct glabrous pygidial area (Smicromyrmillini) . . . . . *Smicromyrmilla* (including *Eosmicromyrmilla* and *Hindustanilla*)
- 5 (a) Body length  $> 4$  mm; eye large relative to head (ratio of eye height to head height  $> 0.6$ ); eye with  $> 400$  small ommatidia; second metasomal tergum about  $1.5\times$  as wide as long . . . . . *Areotilla*  
 (b) Body length  $< 3$  mm; eye small relative to head (ratio of eye height to head height  $< 0.5$ ); eye with  $< 100$  large ommatidia; second metasomal tergum about as wide as long . . . . . *Nanomutilla*

## GEOGRAPHICAL DISTRIBUTION

The subfamily occurs in the southern Palaearctic, Afrotropical and Oriental Regions. The tribes differ in distribution only in that Ticoplini have not yet been found in the Oriental Region. Brothers (1975) proposed that the Ticoplinae arose in eastern Central Africa, and from there spread northwards to the Mediterranean region, southwards into southern Africa and eastwards to the Indian plate, while it was still in contact with Africa or very close to it, i.e. at least about 80 million years ago (Smith, Hurley and Briden 1981). However, this does not account for the apparent absence of Ticoplinae from Madagascar, as reflected by at least two recent collecting expeditions there (from the Natural History Museum (London) and the University of Kansas) which have failed to come up with any specimens, despite their emphasis on Hymenoptera.

## ACKNOWLEDGMENTS

This study formed part of a dissertation submitted by AM in partial fulfilment of the requirements for the M.Sc. at the University of Natal. Financial assistance to DJB from the University of Natal Research Committee is gratefully acknowledged. The curators of the many institutions which loaned specimens are thanked for their assistance, as are the technicians at the Electron Microscopy Centre of the University of Natal (Pietermaritzburg).

## LITERATURE CITED

- André, E. 1896. Notes pour servir à la connaissance des Mutillides paléarctiques et description de quelques espèces nouvelles, deuxième partie. *Mémoires de la Société Zoologique de France* 9: 261–277.  
 André, E. 1900. 2me Genre.—Mutilla, Linné. In: André, E. Monographie des Mutillides d'Europe et d'Algérie. *Spécies des Hyménoptères d'Europe et d'Algérie* 8: 125–135.  
 André, E. 1901a. Matériaux pour servir à la connaissance des Mutillides d'Afrique. *Zeitschrift für systematische Hymenopterologie und Dipterologie* 1: 305–352.  
 André, E. 1901b. 6me Sous-Genre.—Nanomutilla nov. subg. In: André, E. Monographie des Mutillides d'Europe et d'Algérie. *Spécies des Hyménoptères d'Europe et d'Algérie* 8: 223–226, pl. X.

- André, E. 1903. Mutillides d'Afrique nouveaux ou imparfaitement connus. *Zeitschrift für systematische Hymenopterologie und Dipterologie* 3: 81–88, 137–144, 232–239.
- Argaman, Q. 1988. Description of the female of *Ticopla*, with biological and taxonomic notes. *Fragmenta Balcanica* 14: 33–46.
- Arnold, G. 1946. New species of African Hymenoptera, No. 6. *Occasional Papers of the National Museum of Southern Rhodesia* 2: 49–55.
- Arnold, G. 1960. New species of African Hymenoptera, No. 15. *Occasional Papers of the National Museum of Southern Rhodesia* 24: 457–461.
- Ashmead, W. H. 1903. Classification of the fossorial, predaceous and parasitic wasps, or the superfamily Vespoidea. *Canadian Entomologist* 35: 323–332.
- Bischoff, H. 1920–1921. Monographie der Mutilliden Afrikas. *Archiv für Naturgeschichte (A)* 86: 1–830.
- Brothers, D. J. 1975. Phylogeny and classification of the aculeate Hymenoptera, with special reference to Mutillidae. *University of Kansas Science Bulletin* 50: 483–648.
- Brothers, D. J. 1993. Family Mutillidae. In: Goulet, H. and Huber, J. T. eds, *Hymenoptera of the World: An Identification Guide to Families*. Agriculture Canada Research Branch, Ottawa. pp. 187–201.
- Brothers, D. J. 1999. Phylogeny and evolution of wasps, ants and bees (Hymenoptera, Chrysidoidea, Vespoidea and Apoidea). *Zoologica Scripta* 28: 233–249.
- Cameron, P. 1897. Hymenoptera Orientalia, or Contributions to a knowledge of the Hymenoptera of the Oriental Zoological Region. Part V. *Manchester Memoirs* 41 (4): 1–144, pl. 3–4.
- Day, M. C. 1984. The enigmatic genus *Heterogyna* Nagy (Hymenoptera: Sphecidae: Heterogyninae). *Systematic Entomology* 9: 293–307.
- Farris, J. S. 1988. *Hennig86*, version 1.5. [Computer software and manual]. Port Jefferson Station, New York.
- Gauld, I. and B. Bolton (eds). 1988. *The Hymenoptera*. Oxford University Press, Oxford.
- Goloboff, P. A. 1993. Estimating character weights during tree search. *Cladistics* 9: 83–91.
- Goloboff, P. A. 1994. *Pec-Wee*, version 2.15. [Computer software and manual]. Tucumán.
- International Commission on Zoological Nomenclature. 1987. Opinion 1445 Heterogynidae Rambur, 1866 (Insecta, Lepidoptera) and Heterogynidae Nagy, 1969 (Insecta, Hymenoptera): a ruling to remove the homonymy. *Bulletin of Zoological Nomenclature* 44: 150–151.
- International Commission on Zoological Nomenclature. 1999. *International Code of Zoological Nomenclature*, 4th edition. International Trust for Zoological Nomenclature, London.
- Lelej, A. S. and K. V. Krombein. 2001. Review of the Oriental mutillid wasps of the subfamily Tico-plinae (Hymenoptera, Mutillidae). *Far Eastern Entomologist* 99: 1–18.
- Lelej, A. S. and P. G. Némkov. 1997. Phylogeny, evolution and classification of Mutillidae (Hymenoptera). *Far Eastern Entomologist* 46: 1–24.
- Melo, G. A. R. 1999. Phylogenetic relationships and classification of the major lineages of Apoidea (Hymenoptera), with emphasis on the crabronid wasps. *Scientific Papers, Natural History Museum, The University of Kansas* 14: 1–55.
- Mitchell, A. and D. J. Brothers. 1998. Revision and cladistic analysis of the Afrotropical genus *Arctotilla* (Hymenoptera: Mutillidae). *African Entomology* 6: 193–214.
- Nagy, C. G. 1970. Further investigations on the heterogynoid wasps. *Entomologische Mitteilungen aus dem Zoologischen Museum Hamburg* 4: 83–86.
- Nixon, K. C. 1994. *Clados*, version 1.6.1. [Computer software and manual]. Ithaca, New York.
- Nonveiller, G. 1973. Recherches sur les Mutillides de l'Afrique (Mutillidae, Hymenoptera). III. Remarques concernant le genre *Nanomutilla* André 1899. *Annales de la Faculté des Sciences au Cameroun* 15–16: 63–73.
- Nonveiller, G. and E. Gros. 1996. Descripción de *Smicromyrmylla miranda* n. sp. (Hymenoptera, Mutillidae) de la Península Ibérica. (Mutillidos paleárticos XII). *Bolletín de la Societat d'Història Natural de les Balears* 39: 59–64.
- Smith, A. G., A. M. Hurley and J. C. Briden. 1981. *Phanerozoic Paleocoontinental World Maps*. Cambridge University Press, Cambridge.
- Suárez, F. J. 1965. Datos preliminares al estudio de los mutillidos ibéricos (Hymenoptera). *Eos* 40: 569–586.
- Suárez, F. J. 1975. Comentarios sobre *Smicromyrmylla* Suárez y *Nanomutilla* André (Hymenoptera, Mutillidae). *Archivos del Instituto de Aclimatación* 20: 109–119.
- Tournier, H. 1895. Sur *Rhinospathus chobauti* Desbr. (Coléoptères) et sur deux Mutilles nouvelles du Maroc (Hyménoptères). *Bulletin de la Société entomologique de France* 1895: 47–49.

## APPENDIX 1

Characters used for cladistic analysis of genera of Tico-plinae. Suffixes: B = applicable to both sexes, F = female only, M = male only. Primitive states coded as 0, derived states as 1 or 2. All characters considered additive.

1B. Eye pubescence. 0 = Present, visible at 20× magnification. 1 = Absent, although pores and/or very sparse short setae may be distinguishable under high magnification. (State 0 is found in most Tiphidae (Brothers 1975), Fedtshenkiinae (Sapygidae), *Myrmosa* and

- Myrmosula*; since almost all Pseudophotopsi-  
dinae and all other mutillids lack eye pubes-  
cence, state 1 has most likely evolved inde-  
pendently within the Ticoplinae.)
- 2B. Antennal tubercles. 0 = Separate although  
closely approximated, not joined by a straight  
transverse ridge, scarcely protruding. 1 =  
Fused medially, joined by a straight trans-  
verse ridge, distinctly protruding.
- 3B. Pronotum, dorsal and anterior faces. 0 =  
Smoothly and evenly merging, without a  
transverse carina. 1 = Sharply separated by a  
distinct transverse carina, at least laterally.  
(Of the out-group genera, *Pseudophotopsis* has  
state 0, *Dasylabris* has state 1, while *Myrmosa*  
and *Myrmosula* appear variable. As none of  
the out-group taxa have state 1 developed as  
strongly as in the in group, this state is con-  
sidered apomorphic.)
- 4B. Propodeum, disc and declivity distinction.  
0 = Smoothly merging, not distinct. 1 = Dis-  
tinct, in different planes.
- 5B. Felt line on metasomal sternum 2. 0 = Ab-  
sent. 1 = Present. (Brothers (1975) stated that  
"... the tendency toward development of  
[tergal] felt lines is considered to have been  
established after the divergence of the Myr-  
mosinae" which have neither tergal nor ster-  
nal felt lines (like the Rhopalomutillinae, in  
which traces of tergal felt lines are present in  
only a few males). Referring to the phylogeny  
of the Mutillidae (Fig. 1) this indicates that  
the actual development of tergal felt lines has  
apparently occurred on two occasions, once  
in *Pseudophotopsis* and again on internode 4-  
5. Similarly, when considering sternal felt  
lines, which are present in *Pseudophotopsis*,  
*Smicromyrmilla* and sporadically within taxa  
derived above Rhopalomutillinae, it is most  
parsimonious to consider felt lines to have  
been developed independently on several oc-  
casions. Thus, absence of felt lines is plesiom-  
orphic for the Ticoplinae.)
- 6M. Eye, inner margin shape. 0 = Shallowly  
emarginate at or below mid height. 1 =  
Strongly notched above mid height.
- 7M. Scape, ventral longitudinal carinae. 0 =  
One (lateral). 1 = Two (mesal and lateral).  
(Primitively, there is only one longitudinal ca-  
rina on the scape, or none. Although *Dasyla-  
bris* has two carinae, this appears to have  
been derived separately in many higher taxa.)
- 8M. Ratio of tegula length to mesoscutum  
length. 0 =  $< 0,60$ . 1 =  $> 0,75$ .
- 9M. Scutellum, posterior margin. 0 = Abutting  
metanotum. 1 = More or less lamellate and  
overhanging metanotum.
- 10M. Scutellum and dorsellum, profile. 0 = On  
essentially the same plane. 1 = On two dis-  
tinct planes. (State 0 is found in all out-group  
taxa except for *Dasylabris*.)
- 11M. Propodeum, fields. 0 = Three small fields  
on anterior half defined by weakly developed  
carinae, many mini fields on posterior half. 1  
= Five large fields defined by very well de-  
veloped carinae. 2 = Three very large fields  
defined by well developed carinae. (This  
character was treated as additive because the  
states are complex, with state 1 appearing to  
be intermediate between 0 and 2.)
- 12M. Propodeum, extent of disc and declivity.  
0 = Disc about as long as declivity height. 1  
= Disc at least  $1.5\times$  as long as declivity  
height.
- 13M. Metasomal sternum 2, short median lon-  
gitudinal basal carina. 0 = Absent. 1 = Pre-  
sent.
- 14M. Hypopygium, apical margin. 0 = Shal-  
lowly emarginate or notched. 1 = With deep  
narrow median split. (State 0 is the more sim-  
ilar to the conditions in all the out-group taxa;  
state 1 is unique in Mutillidae.)
- 15M. Penis valve, relative length. 0 =  $< 0.60\times$   
as long as paramere. 1 =  $> 0.75\times$  as long as  
paramere. (State 0 is found in *Myrmosa* and  
*Pseudophotopsis*, despite the highly derived,  
spinose state of the penis valve in the latter  
subfamily; while *Dasylabris* has state 1, this  
has probably been separately derived.)
- 16M. Paramere curvature. 0 = Straight. 1 =  
Apex strongly curved ventrally.
- 17F. Eye size. 0 = Large (eye height  $> 0.60\times$   
head height) with  $> 400$  small ommatidia. 1  
= Small (eye height  $< 0.50\times$  head height)  
with  $< 100$  large ommatidia.
- 18F. Propodeum, posterolateral spines. 0 =  
None. 1 = One. 2 = At least two. (None of  
the out-group genera has spines on the decliv-  
ity; the development is postulated as pro-  
gressive, the character thus being regarded as  
additive.)
- 19F. Propodeum, lateral carinae. 0 = No dis-  
tinct carinae. 1 = Distinct obliquely trans-  
verse carinae extending posterolaterally.
- 20F. 'Auricle' (Brothers 1975) at base of first me-

tasomal tergum. 0 = Forming slight rounded protuberance. 1 = Forming prominent lamellate or spinose protuberance. (These structures are absent in females of Myrmosinae, fairly well developed in Pseudophotopsidinae and well developed elsewhere although generally not so prominently as in *Smicromyrmylla* females.)

21F. Pygidium. 0 = No defined pygidial area or plate. 1 = Distinct glabrous pygidial area present. (There is no pygidial area in Myrmosinae, but such an area is present in most other Mutillidae, including the other out-group representatives, although it varies considerably in form. The suggested polarity was thus considered the more likely to be correct.)

## Observations of Oviposition Behavior of *Microctonus hyperodae* Loan and *M. aethiopoidea* Loan (Hymenoptera: Braconidae: Euphorinae)

C. B. PHILLIPS

Biocontrol and Biosecurity Group, AgResearch Ltd, PO Box 60, Gerald St,  
Lincoln, New Zealand, email: craig.phillips@agresearch.co.nz

---

*Abstract.*—The oviposition behavior of *Microctonus hyperodae* Loan and *M. aethiopoidea* Loan (Hymenoptera: Braconidae: Euphorinae) was observed in laboratory tests involving two host species, *Listronotus bonariensis* (Kuschel) and *Ireninus aequalis* Broun (both Coleoptera: Curculionidae). The parasitoids exhibited similar behaviors to one another and towards the two hosts, but *M. aethiopoidea* attempted to oviposit more frequently and oviposited less successfully. About 66% of oviposition attempts occurred near the host's anus and 33% occurred near the mouth, of which 8% and 3%, respectively, were successful. On rare occasions, oviposition was attempted near a host's eye, antenna, leg or thorax, but such attempts always failed. Successful oviposition was characterized by insertion of the parasitoid ovipositor followed by tapping of the host with one or both antennae and, in the case of *L. bonariensis*, about 60s of host hyperactivity. Parasitoids were unable to oviposit in motionless hosts, but the hosts did not appear to exploit this as a means of defence. *Microctonus hyperodae* searched segments of ryegrass more often than *M. aethiopoidea*, but neither species appeared attracted to host frass.

---

The genus *Microctonus* (Hymenoptera: Braconidae: Euphorinae) has a cosmopolitan distribution and comprises more than 40 species (Shaw 1985). *Microctonus* species attack adult insects in at least six families of Coleoptera, and several species are of economic significance because they parasitize coleopteran pests (Abu and Ellis 1976, Drea *et al.* 1972, Goldson, McNeill, Proffitt *et al.* 1993).

The life cycle of Euphorinae in general has been summarised by Shaw and Huddleston (1991). *Microctonus* species, like other Euphorinae, have the distinctive habit of attacking hosts by bending the gaster downwards and forwards between the legs, with the ovipositor extended under the thorax and beyond the head towards the target. There are solitary and gregarious *Microctonus* species and, in this genus, the female oviposits in a beetle (usually the adult), whereupon the immature parasitoid develops through five larval instars (Loan and Holdaway 1961a)

within the active, living host. The mature parasitoid larva then emerges from the host to pupate, while the beetle dies.

Many euphorine females have larger eyes than males which suggests vision may be important to oviposition (Shaw 1985). This was supported by research that indicated host shape and color influenced oviposition by *Dinocampus coccinellae* (Schrank) (Richerson and DeLoach 1972, Walker 1961). *Dinocampus coccinellae* also appeared to respond to olfactory cues (Semyanov 1981). Host movement may stimulate oviposition by some species including *Microctonus vittatae* Muesebeck (Smith 1952) and *Microctonus disonychia* Loan (Loan 1967).

Several host species have exhibited defensive behaviors, such as jumping or flying, when being attacked by either *M. vittatae* (Smith 1952, Wylie and Loan 1984), *M. aethiopoidea* Loan (Munro and Post 1948), or *M. elcodis* (McColloch 1918). *Microctonus aethiopoidea* (Loan and Holdaway

1961a) and *M. vittatae* (Smith 1952, Wylie and Loan 1984) were sometimes forced by the host's hard integument to attempt oviposition repeatedly before successfully penetrating into the host's hemocoel. *Microctonus* species have been observed ovipositing in membranous areas of the host near the caudal end of the abdomen (Loan 1960, 1963, 1967, Loan and Holdaway 1961a), in or near the mouth (Wylie 1985, Wylie and Loan 1984) and, in the case of *M. apiophaga* Loan, through the base of an antenna (Freeman 1967, Loan 1974). Females usually deposited a single egg free in the hemocoel of the host (Loan 1960, Smith 1952, Wylie 1985), although an egg was not always laid when the ovipositor was inserted (Loan 1967, Loan and Holdaway 1961a, Wylie 1985). Egg deposition occurred in less than a few seconds (Loan 1960, Smith 1952).

*Microctonus hyperodae* Loan is thelytokous and *M. aethiopoulos* is arrhenotokous. Both are solitary. *M. hyperodae* is native to South America (Loan and Lloyd 1974) and was introduced to New Zealand in 1991 to assist management of *Listronotus bonariensis* (Kuschel) (Coleoptera: Curculionidae) (Goldson, McNeill, Proffitt *et al.* 1993), a major pest of Graminae in New Zealand (Goldson *et al.* 1998). *Microctonus hyperodae* parasitizes several non-target species in the laboratory, particularly the New Zealand native *Irenimus aequalis* (Broun) (Coleoptera: Curculionidae) (Goldson *et al.* 1992), but post-release monitoring has indicated it is restricted to *L. bonariensis* in the field (Barratt *et al.* 1997).

*Microctonus aethiopoulos* is widely distributed in Europe and has also been introduced to North America (van Driesche and Gyrisco 1979), Australia (Aeschlimann 1983) and New Zealand (Goldson, McNeill, Proffitt *et al.* 1993) to assist control of weevils of the genera *Sitona* and *Hypera* which are pests of Fabaceae. New Zealand's *M. aethiopoulos* population is thought to have originated from Morocco

and possibly Greece (Aeschlimann 1983, 1995) and has suppressed its target, *Sitona discoideus* Gyllenhal, which is a pest of lucerne (Goldson *et al.* 1990, Kean and Barlow 2000). *Microctonus aethiopoulos* also attacks 13 non-target species in New Zealand, including *I. aequalis* and *L. bonariensis* (Barratt *et al.* 1997, 2000). Another European strain of *M. aethiopoulos* has recently been imported to New Zealand quarantine where its suitability for use in a biological control programme against a clover pest, *Sitona lepidus* Gyllenhal, is being examined (Goldson *et al.* 2001, Phillips *et al.* 2000).

This paper reports observations of the oviposition behavior of *M. hyperodae* and *M. aethiopoulos*, in two of their host species, *L. bonariensis* and *I. aequalis*. The oviposition behavior of *M. hyperodae* has not previously been reported, while that of *M. aethiopoulos* has only been briefly noted (Loan and Holdaway 1961a, Munro and Post 1948).

## MATERIALS AND METHODS

Insects were contained in plastic arenas (35 × 35 × 8 mm) covered with colorless glass (40 × 40 × 1 mm) and ventilated by pricking 3–5 holes in each side wall with a minuten pin. Arenas were replaced after every test. Two 20 mm long segments of ryegrass leaf (*Lolium multiflorum* Lam. cv. Tama) grown in a greenhouse and not previously exposed to weevils or parasitoids were secured in the arena by cutting one or two slits in the wall of the container with a scalpel and inserting one end of each segment in a slit. This restricted movement of the grass during weevil feeding and minimised possible disruption to parasitoid activity. All observations involved one adult parasitoid female and two conspecific adult weevils. Differences in size and coloration enabled weevil individuals to be distinguished during an observation.

Video equipment was used to create an enlarged image (up to c. 40× magnifica-

tion) of the insects and to make recordings of their behavior. This equipment consisted of a video camera (JVC TK-1280E) equipped with a macro lens (AF Micro-Nikkor 60 mm f/2.8) mounted on a stand with vertical adjustment (Kaiser RS 2 5410), a video monitor (JVC TM-1500PS) and a video recorder (Panasonic NV-FS88 HQ).

A computer program was coded in Turbo Pascal, version 7.0 (Borland International 1992) which enabled a computer to be used as an event recorder. Essentially, this involved assigning computer keyboard buttons to pre-defined behavioral events. When an assigned key was pressed, the time (from the DOS computer clock) and occurrence of the event was recorded in a file and displayed on the computer monitor.

*Behaviors Quantified Using Event Recorder:*

*Abdomen Strike.*—Parasitoid faced the apex of a weevil's abdomen and attempted to insert the ovipositor between the elytra and pygidium. The distal end of the ovipositor appeared to touch, or be within 2 mm of, the weevil.

*Antennation.*—Parasitoid touched the weevil with one or both antennae.

*Head Strike.*—Parasitoid faced either the head or thorax of a weevil, and attempted to insert the ovipositor in parts of the weevil's head other than its mouth, including the anterior margin of the pronotum. The distal end of the ovipositor appeared to touch, or be within 2 mm of, the weevil.

*Mouth Strike.*—Parasitoid faced either the head or the thorax of a weevil, and attempted to insert the ovipositor in or about the weevil's mouth. The distal end of the ovipositor appeared to touch, or be within 2 mm of, the weevil.

*Oviposition Likely.*—Parasitoid ovipositor penetrated the host.

*Parasitoid-weevil encounter.*—A parasitoid appeared to respond to a weevil.

*Searched Ryegrass.*—Parasitoid walked on ryegrass while tapping it with its antennae.

*Stalking Ceased.*—Parasitoid ceased pursuit of a moving weevil, or moved away from a motionless weevil which it had previously been stalking.

*Stalking.*—A parasitoid pursued a moving weevil, or remained within 5 mm of a stationary host and appeared to observe it.

*Thorax Strike.*—Parasitoid faced either the head or thorax of a weevil, and attempted to insert the ovipositor in the weevil's thorax, including the basal margin of the pronotum. The distal end of the ovipositor appeared to touch, or be within 2 mm of, the weevil.

*Data analysis.*—The event count data were analysed using the statistical package Genstat (v. 5.42) with a general linear model and a Poisson error distribution (McCullagh and Nelder 1983). An offset (Genstat 5 Committee 2000) was used to account for the varying durations of the observations. The significances of differences between observations in event counts were tested using log likelihood ratios (McCullagh and Nelder 1983).

*Source of insects.*—Adults of *L. bonariensis* and *I. aequalis* were swept from pasture in Canterbury, New Zealand. *Microctonus aethiopoidea* used in the observations were reared from *L. bonariensis* and *I. aequalis* as described by Goldson, McNeill, Proffitt *et al.* (1993). *Microctonus hyperodae* were obtained from a laboratory culture at Ag-Research, Lincoln (Goldson, McNeill, Proffitt *et al.* 1993).

## RESULTS

The number of observations and the total time spent observing each of the four

Table 1. Number of observations, observation time and frequency data ( $\pm$  SE of mean) for each combination of parasitoid and host species.

	<i>Listronotus bonariensis</i>		<i>Ireninus aequalis</i>	
	<i>Microctonus hyperodae</i>	<i>Microctonus aethioides</i>	<i>Microctonus hyperodae</i>	<i>Microctonus aethioides</i>
Observations (n)	101	10	32	8
Total observation time (hours)	48	5	10.5	3.5
Oviposition attempts (per hour)	9.7 $\pm$ 1	12.7 $\pm$ 3.6	5.2 $\pm$ 1.6	18.0 $\pm$ 5.1
Ovipositor insertions (per hour)	0.7 $\pm$ 0.1	0.4 $\pm$ 0.3	0.2 $\pm$ 0.1	1.5 $\pm$ 0.6
Abdomen strikes (per hour)	6.3 $\pm$ 0.7	8.7 $\pm$ 2.6	1.2 $\pm$ 0.8	13.4 $\pm$ 3.8
Ovipositor insertions via abdomen (per hour)	0.41 $\pm$ 0.1	0.21 $\pm$ 0.2	0.10 $\pm$ 0.1	0.87 $\pm$ 0.4
Ovipositions via abdomen confirmed (n)	12	0	0	2
Thorax strikes (per hour)	0.1 $\pm$ 0.02	0	0.2 $\pm$ 0.06	0
Mouth strikes (per hour)	1.4 $\pm$ 0.2	4.0 $\pm$ 1.3	1.7 $\pm$ 0.6	3.8 $\pm$ 1.5
Ovipositor insertions via mouth (per hour)	0.2 $\pm$ 0.03	0.0 $\pm$ 0.0	0.0 $\pm$ 0.0	0.0 $\pm$ 0.0
Ovipositions via mouth confirmed (n)	6	0	0	1
Returns to weevil to antennate (per hour)	0.23 $\pm$ 0.05	0	0.1 $\pm$ 0.07	0.29 $\pm$ 0.2

combinations of parasitoid and host species is presented in Table 1. The mean temperature during the observations was 22°C (range 16–30°C).

In the following, the word 'parasitoid' is used when describing behaviours observed in both *M. hyperodae* and *M. aethioides*. Similarly, 'weevil' is used when describing behaviours observed in both *L. bonariensis* and *I. aequalis*. Species names are used when describing behaviours that differed between species.

*Host searching.*—*Microctonus hyperodae* searched ryegrass 1.2  $\pm$  0.2 times per hour (TPH), while *M. aethioides* searched it significantly less frequently (0.1  $\pm$  0.2 TPH,  $P = 0.003$ ). *Microctonus hyperodae* searched ryegrass by walking along the leaf segment while tapping it repeatedly with its antennae. Plant material which was damaged either mechanically or by weevil feeding was searched particularly thoroughly. Parasitoids usually paid no attention to frass deposited by weevils in the container. The single exception was a

*M. hyperodae* that investigated fresh *I. aequalis* frass in a manner similar to that observed when *M. hyperodae* searched damaged sections of ryegrass.

A parasitoid often seemed initially to ignore the two weevils confined with it, and sometimes groomed until a host approached it. This is indicated by the mean of 149  $\pm$  19 s which elapsed until the first encounter between a parasitoid and weevil. Encounters occurred a mean of 13.2  $\pm$  0.4 TPH, and weevils initiated these a mean of 3.4  $\pm$  0.2 TPH. Once a parasitoid was within 5 mm of a moving weevil, it seldom disregarded it and usually began to stalk it at least for several seconds and, in some cases, for several hours. Parasitoids occasionally appeared aware of a weevil's presence prior to seeing it, whereupon the parasitoid searched the container while rapidly waving the antennae backwards and forwards and moving the head from side to side.

*Host recognition and acceptance.*—A parasitoid appeared to detect a weevil from

5–15 mm away, whereupon it faced the potential host with its antennae nearly motionless and directed towards the weevil. The parasitoid then approached the weevil in an alert and cautious manner until the two insects were less than the length of a parasitoid antenna apart. Parasitoids approached weevils from all angles, although typically they advanced to the weevil's side and extended one antenna to the weevil's head and the other to its caudal apex.

A parasitoid tapped a weevil with an antenna a mean of  $6.2 \pm 0.3$  TPH. This varied from a single very rapid strike at the weevil with one antenna, to a thorough exploration of its surface with both antennae and, hereafter, is referred to as 'antennation'. In six tests, a parasitoid grasped a beetle's abdomen with its forelegs and antennated the host assiduously (observed with all species-combinations except *M. aethiopoides*/*I. aequalis*). The parasitoid antennated the host then ceased stalking it a mean of  $3.0 \pm 0.2$  TPH.

A motionless weevil usually adopted a crouched position with its ventral surface touching the substrate on which it was resting. The parasitoid did not attempt to oviposit when confronted with a motionless weevil, but often continued to observe it from about 5 mm away while facing the host's head or the apex of its abdomen. Sometimes the parasitoid moved from one position to the other while waiting for an opportunity to oviposit. Any slight movement of the weevil resulted in an immediate response by the parasitoid whereby it adjusted its position slightly and began to bring the ovipositor forward. The parasitoid sometimes groomed as it watched the weevil and occasionally tapped it with an antenna. This attentive monitoring of a stationary weevil lasted for up to three hours. A parasitoid occasionally left a motionless weevil almost immediately, or abandoned a motionless target for a moving one. Parasitoids abandoned one host to pursue another a mean  $4.5 \pm 0.3$  TPH,

and gave up pursuit for no apparent reason a mean of  $7.8 \pm 0.3$  TPH.

A weevil usually showed no response to parasitoid antennation or oviposition attempts. On the three occasions a weevil appeared to defend itself (*I. aequalis* = 2, *L. bouariensis* = 1), it kicked or prodded the parasitoid with a leg, but this did not deter further attempts at parasitism. Once, a *M. hyperodae* appeared to begin to insert its ovipositor in or near the eye of a *L. bouariensis*, whereupon the weevil immediately lowered its head, withdrew it into the thorax as far as possible, and lowered its antennae, thus resisting the oviposition attempt.

*Oviposition.*—The ovipositor often appeared to be used to probe and search the weevil's exterior for an opening. The parasitoid was able to manipulate its abdominal muscles and sheaths to direct the ovipositor very precisely. When directing the ovipositor, the parasitoid's eyes were directed at the part of the host into which it was attempting to oviposit. As the ovipositor was pushed forwards, the antennae moved backwards in a reciprocal manner. Parasitoids only attempted to oviposit in weevils that were active (*i.e.*, walking, grooming, feeding, defecating or initiating mating). Although parasitoids were observed attempting to oviposit as two weevils were initiating mating, no parasitoid inserted its ovipositor into a host that was copulating. Parasitoids appeared undeterred by weevils that had lost a leg segment.

Parasitoids attempted oviposition  $9.7 \pm 0.4$  TPH, but the ovipositor was only inserted  $0.7 \pm 0.1$  TPH. Although *M. hyperodae* attempted oviposition in *L. bouariensis* less often than *M. aethiopoides* (Table 1,  $P = 0.02$ ), it inserted its ovipositor more often (Table 1,  $P = 0.02$ ). *Microctonus aethiopoides* attempted to parasitize *I. aequalis* more frequently than *M. hyperodae* (Table 1,  $P = 0.02$ ), and also inserted its ovipositor into *I. aequalis* more frequently (Table 1,  $P = 0.02$ ).

With both host species, *M. aethiopoidea* made more abdomen strikes than *M. hyperodae* (Table 1,  $P = 0.01$ ), but was more successful at inserting the ovipositor via the abdomen only of *I. aequalis* (Table 1,  $P = 0.04$ ). Oviposition was confirmed after ovipositor insertion had been observed in fourteen of the seventeen cases checked (Table 1; six ovipositions by *M. hyperodae* and one by *M. aethiopoidea* confirmed by maintaining the host until parasitoid emergence, remainder confirmed by dissection of the host). Each larva was found in the host abdomen during dissections.

Abdomen strikes were observed during all forms of weevil activity, particularly when weevils were walking and also shortly after they had stopped walking (e.g., to groom). A parasitoid pursued a walking weevil with the ovipositor either in an egg-laying position, or in a non-ovipositional stance. The parasitoid often appeared unable to force the ovipositor between sternite VI and the apical margin of the weevil elytra. In four tests, the weevil (*L. bonariensis* = 3, *I. aequalis* = 1) drew its elytra down during an ovipositor insertion and the *M. hyperodae* ovipositor appeared to become jammed underneath it. In these cases, the *M. hyperodae* beat its wings while trying to withdraw its ovipositor, and the weevil attempted to move in the opposite direction. The *M. hyperodae* and weevil both seemed agitated for c. 30 s after the ovipositor was withdrawn, but appeared unharmed.

*Microctonus hyperodae*, but not *M. aethiopoidea*, attempted oviposition in the thoracic region of both host species (Table 1,  $P = 0.01$ ). In the clearest case, the ovipositor was directed about the weevil's mesepisternum or prosternum. These attempts usually took the form of one or more rapid thrusts with the ovipositor, rather than the slower probes that were more typical. Some oviposition attempts in the thoracic region occurred while the weevil was walking in which case the *M. hyperodae* crabbed sideways remaining

abreast of the host. No oviposition attempts in the thoracic region resulted in ovipositor insertion. Two *M. hyperodae* tried unsuccessfully to insert the ovipositor between two segments of a *L. bonariensis* leg, at the distal end of a basitarsus.

Parasitoids attempted to oviposit in, or about, the mouth of weevils  $1.7 \pm 0.2$  TPH, and these attempts occurred while hosts were feeding, walking, and grooming. With both host species, *M. aethiopoidea* attempted more mouth strikes than *M. hyperodae* (Table 1,  $P = 0.02$ ). Despite this, *M. aethiopoidea* was less successful than *M. hyperodae* at inserting the ovipositor into the mouth of *L. bonariensis* (Table 1,  $P = 0.001$ ). Ovipositor insertion into the weevil mouth was confirmed by dissection to have resulted in egg deposition in each of the seven cases checked (Table 1). Each *M. hyperodae* larva was found in the *L. bonariensis* abdomen, while the *M. aethiopoidea* larva was found in the *I. aequalis* thorax.

Parasitoids were relatively successful at inserting their ovipositors into the mouths of hosts that were feeding. To achieve this, a parasitoid positioned itself adjacent to either the host head, the pronotum, or the basal end of the abdomen, and then extended its ovipositor underneath the weevil, between and beyond its legs, towards its mouth. While the weevil fed, the parasitoid positioned its ovipositor in the vicinity of the weevil's mouth. As the weevil grazed, it moved its mouth backwards and forwards along the grass surface, and it appeared in some cases that it inadvertently attempted to eat the end of the parasitoid ovipositor. In other cases, the parasitoid thrust its ovipositor forward at the mouth.

A weevil was also at risk from parasitism through the mouth when grooming an antenna. The weevil groomed an antenna by laying it down, stepping on it with a foreleg, then pulling it through the spurs at the tip of the protibia by drawing the head upwards and backwards. This was repeated numerous times during a

grooming session and, as the weevil's head moved up and down, an attendant parasitoid was provided with the opportunity to deposit an egg via the weevil's mouth.

Attempts by parasitoids to oviposit in the mouth of a walking weevil were made by facing the host's head whilst walking backwards ahead of it and making a series of thrusts with the ovipositor. Such efforts appeared rather incidental and did not result in ovipositor insertion. The ovipositor occasionally appeared to be directed more towards either the posterior margin of the weevil's eye, the membrane between the head and pronotum, or the base of an antenna.

When feeding, *L. bonariensis* devoured the upper surface of ryegrass leaf and left the lower epidermis intact which resulted in a characteristic window pane effect in damaged leaves. One *M. hyperodae* attempted repeatedly, but unsuccessfully, to insert its ovipositor through the lower epidermis of the leaf into the weevil's mouth as it was feeding.

When ovipositing, the parasitoid thrust its ovipositor forward, while its abdomen momentarily became distended and the antennae were oriented backwards almost horizontally over the folded wings. The parasitoid shook slightly as if straining to extend its ovipositor to its maximum extension. The ovipositor was inserted for less than a second then withdrawn, whereupon the parasitoid moved its antennae near to and eventually touching the weevil, usually about the dorsal surface of the abdomen. This behavior was particularly striking as the antennae would palpitate rapidly over the weevil as well as often on the ryegrass or plastic on which it was standing. An antenna sometimes touched a host leg, or tarsus, at which the weevil sometimes responded by moving its leg, or walking away. After c. 30 s (range 5–80 s), the parasitoid abruptly finished antennating, then turned away and groomed the ovipositor with the hind

legs, or the antennae with the forelegs. A parasitoid sometimes remained c. 8 mm from the host for c. 60 s (range 0–120 s), before leaving to search or groom elsewhere.

Following 29% of ovipositor insertions ( $n = 45$ ), the parasitoid left the weevil then returned to it at least once (range 1–3 times) to briefly antennate it (Table 1). This behaviour was observed with all insect-combinations except *M. aethioides* and *L. bonariensis* (Table 1). The mean time between leaving the weevil and the subsequent antennation was c. 6 minutes (range 11 s–25 minutes,  $n = 13$ ). After 24% of ovipositor insertions, the parasitoid returned and attempted to oviposit again, although two successful ovipositor insertions in one weevil by the same parasitoid individual never occurred. A parasitoid stalked a new host as little as 60 s after an ovipositor insertion.

*Host response to oviposition.*—Sometimes there was no immediate response to parasitoid ovipositor-insertion, while, on other occasions, the newly parasitized weevil abruptly discontinued an activity (e.g., grooming) and raised its head for several seconds. Of seven confirmed ovipositions via the mouth (Table 1), immediate responses were observed four times (*M. hyperodae* and *L. bonariensis*,  $n = 3$ ; *M. aethioides* and *I. aequalis*,  $n = 1$ ). The weevil stopped eating, the head was raised, the antennae were withdrawn into the scrobes and the head was moved from side to side for 20–45 s.

About 30–60 s after ovipositor insertion, a newly parasitized *L. bonariensis* ( $n = 18$ ) began walking quickly back and forth in a seemingly disoriented fashion, stopping sporadically to groom its antennae and rostrum with its forelegs. This continued for 100–220 s, whereupon it resumed normal pre-ovipositor insertion behavior. *I. aequalis* did not respond in this way after parasitoid ovipositor insertion ( $n = 3$ ).

*Recognition of oviposition.*—Each time parasitoid oviposition was confirmed ( $n =$

21), the following sequence of events occurred. The parasitoid inserted its ovipositor into the host for up to 1 s either near the caudal end of the abdomen or about the mouth, while the antennae were oriented backwards almost horizontally over the folded wings. The ovipositor was then withdrawn and the antennae brought forward very close to the host, eventually touching it. The weevil was always tapped with an antenna at least once, and was often antennated thoroughly. About 45 s after *M. hyperodae* had withdrawn its ovipositor, *L. bonariensis* (n = 18), but not *L. aequalis* (n = 2), became hyperactive for up to 220 s, whereupon the *M. hyperodae* discontinued stalking and turned away. The *M. hyperodae* often returned to antennate or stalk the newly parasitized weevil, but did not usually re-attempt oviposition.

In three out of 24 cases, weevils were maintained after parasitoid ovipositor insertion was observed, but no immature parasitoids were found. Two such 'non-reproductive' ovipositor insertions occurred when the *M. hyperodae* ovipositor appeared jammed in a weevil abdomen (*L. aequalis* = 1, *L. bonariensis* = 1) and once when the *M. hyperodae* ovipositor was inserted into the abdomen of an *L. aequalis* as it was defecating. Parasitoid antennation and *L. bonariensis* hyperactivity did not occur in these cases.

## DISCUSSION

*Microctonus hyperodae* and *M. aethiopoides* appeared to use their eyes and antennae when searching and ovipositing which was consistent with earlier evidence that visual and volatile chemical cues are important in host finding and oviposition by Euphorinae (Semyanov 1981, Walker 1961). Both parasitoid species often encountered stationary weevils and then monitored them attentively, thus suggesting host movement may not be as important to them for host recognition as has been postulated for some other euphorines (Loan 1967, Smith 1952).

*Microctonus hyperodae* and *M. aethiopoides* often touched weevils with one or both antennae upon encountering them. This is similar to the behavior of *D. coccinellae* (Bryden and Bishop 1945, Semyanov 1981, Sluss 1968), but did not seem to constitute an attempt to make the host move as suggested for *D. coccinellae* (Sluss 1968). Stationary weevils touched by a parasitoid antenna never responded, even when they were antennated assiduously. Furthermore, *M. hyperodae* and *M. aethiopoides* almost always touched a weevil with an antenna even if the host was already moving. Antennation, therefore, seemed more likely to be part of the host recognition or host acceptance process.

*Microctonus hyperodae* and *M. aethiopoides* were unable to oviposit in weevils which had adopted their typical resting position. This strongly supported earlier suggestions that motionless hosts are protected from parasitism (Balduf 1926, Fusco and Hower 1973, Richerson and DeLoach 1972). In contrast, weevils seemed most susceptible to parasitism when feeding and grooming. During these activities, the weevil's mouth and the caudal end of its abdomen remained exposed for parasitoid oviposition, while its movements were sufficiently minor to allow a parasitoid to oviposit. A weevil seemed less susceptible to parasitism when walking than when feeding or grooming because its more coarse movements meant that a stalking parasitoid could not insert its ovipositor as readily. A *L. bonariensis* female would probably also be vulnerable to parasitism while preparing to oviposit because it spends c. 200 s chewing a hole in a grass tiller into which to deposit an egg (Pilkington 1987). (In New Zealand, gravid *L. bonariensis* females from the autumn generation are sufficiently long-lived to support the larval development of *M. hyperodae* and *M. aethiopoides* (Goldson *et al.* 1998).)

That *L. bonariensis* is susceptible to parasitism only when it is active suggests

there should be a relationship between parasitism rates and *L. bonariensis* feeding and oviposition. Field data are consistent with this idea because ryegrass infected with the endophytic fungus *Neotyphodium lolii* (Latch, Christensen and Samuels) Glenn, Bacon, Price and Hanlin is resistant to feeding and oviposition by *L. bonariensis* owing to the presence of the alkaloid peramine (Rowan and Gaynor 1985), and the peramine content of ryegrass was found in field trials to have a significant, inverse, linear effect on rates of parasitism of *L. bonariensis* by *M. hyperodae* (Goldson *et al.* 2000). The relationship between parasitism and *L. bonariensis* feeding also suggests that the use of plants should be carefully evaluated both when culturing parasitoids and when designing laboratory experiments for pre-release tests of the efficacy and host range of entomophagous biological control agents (*e.g.*, Barratt *et al.* 1999).

*Listronotus bonariensis* and *I. aequalis* did not exploit the parasitoids' inability to oviposit in motionless weevils as a means of defence. Indeed, with very rare possible exceptions, weevils did not display any defensive behavior at all when threatened by parasitism. (It is reasonable to consider the possibility of *I. aequalis* having a defensive behavior against *Microctonus* species since it coevolved with *M. zealandicus* in New Zealand (Shaw 1993).) This absence of defensive behaviours differs from most other hosts of Euphorinae (Bryden and Bishop 1945, Wylie and Loan 1984), although not *Sitona cylindricollis* Fahraeus (Loan and Holdaway 1961b). In contrast to the results of the present study, however, observations of *L. bonariensis* on upright, potted ryegrass plants showed that the weevils fed less and moved off the foliage towards the soil when *M. hyperodae* was present (Gerard 2000) and that this effect persisted throughout the night (Phillips, unpublished data). Weevils in the vicinity of a parasitoid also exhibited evasive, rapid walking behavior (Gerard

2000). The manifestation of probable defensive behaviours in one test environment, but not another, suggests that a factor as simple as the orientation of plant material in a cage could influence the results of experiments examining parasitoid efficacy and host range, and that considerable preliminary work may be required to design robust experiments.

The response of *L. bonariensis* to parasitoid oviposition whereby it became hyperactive and appeared disoriented has not previously been recorded for hosts of *Microctonus* species, but was consistent with the response of some Coleoptera to oviposition by some other euphorines (Jackson 1928, Sluss 1968). Reasons for such host responses are unknown, but could be associated with compounds injected with the egg to assist in suppression of the host immune system (Stoltz 1986, Vinson 1990, Wharton 1993). *Irenimus aequalis* has also been observed to respond similarly after oviposition by *M. zealandicus* (Phillips, unpublished data).

Antennation of the host shortly after parasitoid oviposition also has not previously been recorded in Euphorinae, but it is known in some other braconid subfamilies such as Rogadinae (Shaw 1983). The parasitoid may be confirming that it has succeeded in ovipositing by detecting some as yet unknown, rapidly occurring, physiological response of the weevil to parasitoid oviposition, or it may be using its antennae to mark the weevil so that it can recognise the host as having been parasitized.

Together, insertion of the parasitoid ovipositor, followed by antennation of the host and host hyperactivity, indicated that a successful oviposition had occurred. This observation should assist in overcoming difficulties in distinguishing between parasitoid oviposition and unsuccessful ovipositor strikes (*e.g.*, Goldson, McNeill and Proffitt 1993).

In laboratory experiments, Goldson, McNeill and Proffitt (1993) recorded sig-

nificantly greater mortality of unparasitised *L. bonariensis* from 3–20 days after exposure to *M. hyperodae* females compared to parasitised *L. bonariensis* and to weevils that had not been exposed to *M. hyperodae*. Furthermore, this unexplained source of *L. bonariensis* mortality associated with *M. hyperodae* appears to be operating in the field (S. L. Goldson, pers. comm., 2002). It was suggested the mortality could be due to weevils suffering multiple parasitoid strikes leading either to loss of haemolymph, disease infection, or to overdoses of *M. hyperodae* venom (Goldson, McNeill and Proffitt 1993). The present study did not support these ideas because parasitoids were either confirmed to have oviposited, or exhibited the behavioral characteristics of having oviposited, whenever the ovipositor was inserted into a host, and there was no evidence that parasitoids inserted the ovipositor for purposes other than oviposition such as host feeding (e.g., Jervis and Kidd 1986). However, the present study observed the interactions between a single parasitoid and two weevils, and it may be that the mechanisms suggested by Goldson, McNeill and Proffitt (1993) only operate when multiple parasitoids are competing for hosts.

*Microctonus hyperodae* and *M. aethiopoidea* approached hosts, pursued them, and attempted to oviposit, in similar ways. However, *M. aethiopoidea* attempted to oviposit more frequently in both weevil species than *M. hyperodae*. This appears consistent with the much more frequent occurrence of *M. aethiopoidea* as a parasite of *I. aequalis* in the field compared to *M. hyperodae* (Barratt *et al.* 1997, Goldson *et al.* 1992). Although *M. aethiopoidea* attempted oviposition more often than *M. hyperodae* in *L. bonariensis*, it was less successful at inserting the ovipositor. The ovipositor of *M. hyperodae* is slightly curved in lateral view, while *M. aethiopoidea*'s is more nearly straight (McNeill *et al.* 1993). Therefore, there may be a degree of physical, rather than behavioral, incompatibility between

*M. aethiopoidea* and *L. bonariensis* which inhibits ovipositor insertion. This could impede the rate of *M. aethiopoidea* oviposition in *L. bonariensis* relative to that of *M. hyperodae*, and may have contributed to the displacement of *M. aethiopoidea* from *L. bonariensis* by *M. hyperodae* that was observed in Canterbury, New Zealand, after the latter parasitoid was introduced in 1991 (J. R. Proffitt, personal communication 1999).

#### ACKNOWLEDGMENTS

The author is grateful for the advice of Dr S. Goldson (AgResearch, Lincoln, NZ), Dr A. Paterson (Lincoln University, NZ), Dr R. Emberson (Lincoln University), Mr J. Proffitt (AgResearch, Lincoln) and Mr M. McNeill (AgResearch, Lincoln). Dr D. Baird (AgResearch, Lincoln) assisted with statistical analyses and Mr I. Laurensen (AgResearch, Lincoln) provided advice on computer programming. An earlier draft of this manuscript was improved by the suggestions of Dr M. Shaw (Royal Museum of Scotland), Dr S. Shaw (University of Wyoming, USA) and an anonymous referee.

#### LITERATURE CITED

- Abu, J. F. and C. R. Ellis. 1976. Biology of *Microctonus aethiopoidea*, a parasite of the alfalfa weevil, *Hypera postica*, in Ontario. *Environmental Entomology* 5(6): 1040–1042.
- Aeschlimann, J.-P. 1983. Sources of importation, establishment and spread in Australia of *Microctonus aethiopoidea* Loeb (Hymenoptera: Braconidae), a parasitoid of *Sitona discoideus* Gyllenhal (Coleoptera: Curculionidae). *Journal of the Australian Entomological Society* 22: 325–331.
- Aeschlimann, J. P. 1995. Lessons from post-release investigations in classical biological control: the case of *Microctonus aethiopoidea* Loeb (Hym., Braconidae) introduced into Australia and New Zealand for the biological control of *Sitona discoideus* Gyllenhal (Col., Curculionidae). In *Biological Control: Benefits and Risks*. Edited by H. M. T. Hokkanen and J. M. Lynch, pp. 75–83, Cambridge University Press, New York.
- Balduf, W. V. 1926. The bionomics of *Dinocampus coccinellae* Schrank. *Annals of the Entomological Society of America* XIX: 465–498.
- Barratt, B. I. P., A. A. Evans, C. M. Ferguson, G. Barker, M. R. McNeill and C. B. Phillips. 1997. Laboratory nontarget host range of the introduced parasitoids *Microctonus aethiopoidea* and *M. hyperodae* (Hymenoptera: Braconidae) compared with

- field parasitism in New Zealand. *Environmental Entomology* 26(3): 694–702.
- Barratt, B. I. P., C. M. Ferguson, E. A. A., M. R. McNeill and P. J. Addison. 2000. Phenology of native weevils (Coleoptera: Curculionidae) in New Zealand pastures and parasitism by the introduced braconid, *Microctonus aethiopoidea* Loan (Hymenoptera: Braconidae). *New Zealand Journal of Zoology* 27: 93–110.
- Barratt, B. I. P., S. L. Goldson, C. M. Ferguson, C. B. Phillips and D. J. Hannah. 1999. Predicting the risk from biological control agent introductions: A New Zealand approach. In *Nontarget effects of biological control*. Edited by P. A. Follett and J. J. Duan, pp. 59–75. Kluwer Academic Publishers, Norwell, Massachusetts.
- Borland International, Inc. 1992. Turbo Pascal Version 7.0 Language Guide: 307p.
- Bryden, J. W. and M. W. H. Bishop. 1945. *Perilitus coccinellae* (Schrank) (Hym., Braconidae) in Cambridgeshire. *The Entomologist's Monthly Magazine* 81: 51–52.
- Drea, J. J., R. J. Dysart, L. W. Coles and C. C. Loan. 1972. *Microctonus stelleri* (Hymenoptera: Braconidae, Euphorinae), a new parasite of the alfalfa weevil introduced into the United States. *The Canadian Entomologist* 104: 1445–1456.
- Freeman, B. E. 1967. The biology of the white clover seed weevil *Apion dichroum* Bedel (Col.: Curculionidae). *Journal of Applied Ecology* 4: 535–552.
- Fusco, R. A. and A. A. Hower. 1973. Host influence on the laboratory production of the parasitoid *Microctonus aethiops* (Nees). *Environmental Entomology* 2(6): 971–975.
- Genstat 5 Committee 2000. *The Guide to Genstat Part 2: Statistics*. VSN International, Oxford. 782p.
- Gerard, P. 2000. Ryegrass endophyte infection affects Argentine stem weevil adult behaviour and susceptibility to parasitism. *New Zealand Plant Protection* 53: 406–409.
- Goldson, S. L., M. R. McNeill, C. B. Phillips and J. R. Proffitt. 1992. Host specificity testing and suitability of the parasitoid *Microctonus hyperodae* (Hym.: Braconidae, Euphorinae) as a biological control agent of *Listronotus bonariensis* (Col.: Curculionidae) in New Zealand. *Entomophaga* 37(3): 483–498.
- Goldson, S. L., M. R. McNeill and J. R. Proffitt. 1993. Unexplained mortality amongst unparasitised *Listronotus bonariensis* in the presence of the parasitoid *Microctonus hyperodae* under caging conditions. *Proceedings of the 6th Australasian Conference on Grassland Invertebrate Ecology*: 355–362.
- Goldson, S. L., M. R. McNeill, J. R. Proffitt, G. M. Barker, P. J. Addison, B. I. P. Barratt and C. M. Ferguson. 1993. Systematic mass rearing and release of *Microctonus hyperodae* (Hym.: Braconidae, Euphorinae), a parasitoid of the Argentine stem weevil *Listronotus bonariensis* (Col.: Curculionidae) and records of its establishment in New Zealand. *Entomophaga* 38 (4): 527–536.
- Goldson, S. L., C. B. Phillips, M. R. McNeill, J. R. Proffitt and R. P. Cane. 2001. Importation to New Zealand quarantine of a candidate biological control agent of clover root weevil. *New Zealand Plant Protection* 54: 147–151.
- Goldson, S. L., J. R. Proffitt and D. B. Baird. 1998. The bionomics of *Listronotus bonariensis* (Coleoptera: Curculionidae) in Canterbury, New Zealand. *Bulletin of Entomological Research* 88: 415–423.
- Goldson, S. L., J. R. Proffitt, L. R. Fletcher and D. B. Baird. 2000. Multitrophic interaction between the ryegrass host plant, *Lolium perenne*, its endophyte *Neotyphodium lolii*, the weevil pest *Listronotus bonariensis* and its parasitoid *Microctonus hyperodae* Loan. *New Zealand Journal of Agricultural Research* 43: 227–233.
- Goldson, S. L., J. R. Proffitt and M. R. McNeill. 1990. Seasonal biology and ecology of *Microctonus aethiopoidea* (Hymenoptera: Braconidae), a parasitoid of *Sitona* spp. (Coleoptera: Curculionidae) with special emphasis on atypical behaviour. *Journal of Applied Ecology* 27: 703–722.
- Jackson, D. J. 1928. The biology of *Diinocampus* (*Perilitus*) *rutilus* Nees a braconid parasite of *Sitona lineata* L.—Part I. *Proceedings of the Zoological Society of London* 2: 597–630.
- Jervis, M. A. and N. A. C. Kidd. 1986. Host feeding strategies in hymenopteran parasitoids. *Biological Reviews* 61: 395–434.
- Kean, J. M. and N. D. Barlow. 2000. Long-term assessment of the biological control of *Sitona discoides* by *Microctonus aethiopoidea* and test of a model. *Biocontrol Science and Technology* 10: 215–221.
- Loan, C. C. 1960. The biology of insect parasitoids of the genus *Sitona* Germar (Coleoptera: Curculionidae). *Unpublished Ph.D. thesis*, University of Minnesota: 170p.
- Loan, C. C. 1963. The bionomics of *Sitona scissifrons* (Coleoptera: Curculionidae) and its parasite *Microctonus sitonae* (Hymenoptera: Braconidae). *Annals of the Entomological Society of America* 56: 600–611.
- Loan, C. C. 1967. Studies on the taxonomy and biology of the Euphorinae (Hymenoptera: Braconidae). II. Host relations of six *Microctonus* species. *Annals of the Entomological Society of America* 60(1): 236–240.
- Loan, C. C. 1974. *Microctonus apiophaga*, new species, (Hymenoptera: Braconidae, Euphorinae) a parasite of adult *Apion* weevils in Britain (Coleoptera: Curculionidae). *Proceedings of the Entomological Society of Washington* 76(2): 186–189.
- Loan, C. C. and F. G. Holdaway. 1961a. *Microctonus aethiops* (Nees) auctt. and *Perilitus rutilus* (Nees)

- (Hymenoptera: Braconidae), European parasites of *Sitona* weevils (Coleoptera: Curculionidae). *The Canadian Entomologist* XCIII(12): 1057–1078.
- Loan, C. C. and F. G. Holdaway. 1961b. *Pygostolus falcatus* (Nees) (Hymenoptera, Braconidae), a parasite of *Sitona* species (Coleoptera, Curculionidae). *Bulletin of Entomological Research* 52(3): 473–488.
- Loan, C. C. and D. C. Lloyd. 1974. Description and field biology of *Microctonus hyperodae* Loan n. sp. (Hymenoptera: Braconidae, Euphorinae) a parasite of *Hyperodes bonariensis* in South America (Coleoptera: Curculionidae). *Entomophaga* 19(1): 7–12.
- McColloch, J. W. 1918. Notes on false wireworms with special reference to *Eleodes tricolorata* Say. *Journal of Economic Entomology* 11: 212–224.
- McCullagh, P. and J. A. Nelder. 1983. *Generalised linear models*. Chapman and Hall, London. 261p.
- McNeill, M. R., C. B. Phillips and S. L. Goldson. 1993. Diagnostic characteristics and biology of three *Microctonus* spp. (Hymenoptera: Braconidae, Euphorinae) parasitoids of weevils (Coleoptera: Curculionidae) in New Zealand pasture and lucerne. *New Zealand Entomologist* 16: 39–44.
- Munro, J. A. and R. L. Post. 1948. Parasites to aid in the control of the Sweet Clover Weevil. *Science* 108: 609.
- Phillips, C. B., S. L. Goldson, L. Reimer and U. Kuhlmann. 2000. Progress in the search for biological control agents of clover root weevil, *Sitona lepidus* Gyllenhal (Coleoptera: Curculionidae). *New Zealand Journal of Agricultural Research* 43(4): 541–548.
- Pilkington, S. 1987. The behavioural biology of Argentine stem weevil in relation to host plant characters. *Unpublished M.Sc. thesis*, Massey University: 162p.
- Richerson, J. V. and C. J. DeLoach. 1972. Some aspects of host selection by *Perilitus coccinellae*. *Annals of the Entomological Society of America* 65(2): 834–839.
- Rowan, D. D. and D. L. Gaynor. 1985. Isolation of feeding deterrents against Argentine stem weevil from ryegrass infected with the endophyte *Acremonium lolii*. *Journal of Chemical Ecology* 12: 647–658.
- Semyanov, V. P. 1981. Behaviour of *Dinocampus* (= *Perilitus*) *coccinellae* (Schrank) (Hymenoptera: Braconidae) during search for and infection of hosts. In *Insect Behavior as a Basis for Developing Control Measures Against Pests of Field Crops and Forests*. Edited by V. N. Belozherov and V. P. Pristavko, pp. 159–163. Oxonian, New Delhi.
- Shaw, M. R. 1983. On[e] evolution of endoparasitism: the biology of some genera of Rogadinae (Braconidae). *Contributions of the American Entomological Institute* 20: 307–328.
- Shaw, M. R. and T. Huddleston. 1991. *Classification and biology of braconid wasps (Hymenoptera: Braconidae)*. Handbooks for the identification of British insects. Vol. 7, Part 11. Royal Entomological Society of London: 126p.
- Shaw, S. R. 1985. A phylogenetic study of the subfamilies Meteorinae and Euphorinae (Hymenoptera: Braconidae). *Entomography* 1: 277–370.
- Shaw, S. R. 1993. Three new *Microctonus* species indigenous to New Zealand (Hymenoptera: Braconidae). *The New Zealand Entomologist* 16: 29–39.
- Sluss, R. 1968. Behavioral and anatomical responses of the convergent lady beetle to parasitism by *Perilitus coccinellae* (Schrank) (Hymenoptera: Braconidae). *Journal of Invertebrate Pathology* 10: 9–27.
- Smith, O. J. 1952. Biology and behaviour of *Microctonus vittatae* Muesebeck (Braconidae), with descriptions of its immature stages. *University of California Publications in Entomology* 9: 315–343.
- Stoltz, D. B. 1986. Interactions between parasitoid-derived products and host insects: an overview. *Journal of Insect Physiology* 32 (4): 347–350.
- van Driesche, R. G. and G. G. Gyrisco. 1979. Field studies of *Microctonus aethioides*, a parasite of the adult alfalfa weevil, *Hypera postica*, in New York. *Environmental Entomology* 8: 238–244.
- Vinson, S. B. 1990. How parasitoids deal with the immune system of their host: An overview. *Archives of Insect Biochemistry and Physiology* 13: 3–27.
- Walker, M. F. 1961. Some observations on the biology of the ladybird parasite *Perilitus coccinellae* (Schrank) (Hym.: Braconidae), with special reference to host selection and recognition. *The Entomologist's Monthly Magazine* 97: 240–244.
- Wharton, R. A. 1993. Bionomics of the Braconidae. *Annual Review of Entomology* 38: 121–143.
- Wylie, H. G. 1985. Posterior dispersal of eggs and larvae of *Microctonus vittatae* (Hymenoptera: Braconidae) in crucifer-infesting flea beetles (Coleoptera: Chrysomelidae). *The Canadian Entomologist* 117: 541–545.
- Wylie, H. G. and C. Loan. 1984. Five nearctic and one introduced euphorine species (Hymenoptera: Braconidae) that parasitize adults of Crucifer-infesting flea beetles (Coleoptera: Chrysomelidae). *The Canadian Entomologist* 116: 235–246.

## Review of *Acrophotopsis* Schuster (Hymenoptera: Mutillidae: Sphaerophthalminae), with Description of a New Species from Baja California

JAMES P. PITTS AND JOSEPH V. MCHUGH

University of Georgia, Department of Entomology, Athens, Georgia 30602, USA,  
JPP email: james.p.pitts@gte.net (Current address: Department of Biology, Utah State University,  
5305 Old Main Hill, Logan UT 84322, USA)

---

*Abstract.*—A new species, *Acrophotopsis mickeli* Pitts, is described based on 102 males collected in Baja California Sur. This raises the number of species of *Acrophotopsis* to four. *Acrophotopsis mickeli* differs from other *Acrophotopsis* species by having the following combination of characters, anterior fourth of the mesopleuron punctate, thin parameres with apices slightly curved dorsally, the cuspis more than eight times as long as wide, the distal third of the middle and hind femora darkened, and the metasoma not concolorous with head and mesosoma. A key is given for the species. Current distributional data and illustrations are given for *A. bergi* Casal, *A. campylognatha* Schuster, and *A. eurygnatha* Schuster.

---

In a study of Mutillidae from the southwestern United States, 102 specimens of an undescribed species of *Acrophotopsis* were found in various collections. Seventy-two specimens were found at the Department of Entomology Collection, University of Arizona, Tucson. These specimens were determined to be *A. campylognatha* by Ferguson in 1961, but our work revealed that they represent an undescribed species. This new species is described, illustrated and discussed below. A key for all species of *Acrophotopsis*, along with current distributional data and illustrations, are also presented. In order to produce this review, however, several other taxonomic issues had to be addressed.

Little published information exists for *Acrophotopsis*. The genus was described by R.M. Schuster (1958) for two new species of Sphaerophthalmini from the Nearctic Region, *A. campylognatha* and *A. eurygnatha*. Males of *Acrophotopsis* are nocturnal and are normally collected with light-traps. They may reside in the leaf litter at the

base of bushes during the day like other nocturnal mutillid males (e.g., *Odontophotopsis* spp.) (Ferguson 1963). Nothing more is known about the biology of *Acrophotopsis*. Females of *Acrophotopsis* remain unknown, but are presumed to be active only at night.

Schuster (1958) included locality data and complete descriptions for the two new species of *Acrophotopsis*. At the time of writing the manuscript, however, he did not label the types for them or for the other 128 newly described species of other genera in the same manuscript. He waited until thirteen years after drafting the manuscript before visiting the various museums housing the material to insert type labels as he saw fit (Ferguson 1967). Due to this oversight, not all of the original specimens were found by Schuster, and some may have been mislabeled.

Several more problems regarding the designation of Schuster's *Acrophotopsis* type material were found during our study. For *A. campylognatha*, sixteen paratypes were found. However, Schuster had

not originally designated any paratypes for this species. Because these specimens were not published in Schuster (1958), they cannot be considered paratypes and have been included here in the material examined section. A similar problem occurs for *A. eurygnatha*. Schuster (1958) designated 16 paratypes for *A. eurygnatha*. Thirteen additional specimens (USNM) are labeled as paratypes, but they are not among the designated paratypes and are not conspecific with *A. eurygnatha*. In actuality, we have identified them as specimens of the new species described here. As with *A. campylognatha*, there may be many more specimens labeled as paratypes of *A. eurygnatha*, and some of them may not be conspecific with *A. eurygnatha*. Without an exhaustive search of all museums, we cannot determine how many other specimens were labeled as paratypes by Schuster after the original description. Schuster did designate holotypes for *A. campylognatha* and *A. eurygnatha*, which have been located and are properly labeled.

Another difficulty with the treatment by Schuster (1958) is that it uses *campylognathus* and *eurygnathus* as the specific epithets of the new species of *Acrophotopsis*. According to Article 30.1.2 of the 4th edition of the Code of Zoological Nomenclature (I.C.Z.N. 1999), names ending in *-opsis* are of feminine gender. Thus, the specific epithets of Schuster's two species of *Acrophotopsis* should be *campylognatha* and *eurygnatha*, rather than *campylognathus* and *eurygnathus*.

Casal (1967) described a third species of *Acrophotopsis*, *A. bergi*, based on a single male specimen from the state of Morelos, Mexico. According to Casal (1967), *A. bergi* differs from the generic characters described by Schuster, but only in the general aspect of genitalic characters. These characters resemble those of *Dilophotopsis*, a genus Schuster (1958) also described. These similarities prompted Casal (1967) to question Schuster establishing *Dilopho-*

*topsis* as a separate genus from *Acrophotopsis* and suggested more work should be done to determine the relationships between them.

Careful examination of specimens of *Acrophotopsis* and *Dilophotopsis* clearly support Casal's concerns. Schuster (1958) noted the following similarities between *Acrophotopsis* and *Dilophotopsis*: 1. hypopygium emarginate distally, 2. mandibles strongly developed, dorsoventrally dilated, 3. parameres strongly flattened, curving mesad, with the apices normally overlapping *in situ*, 4. petiole slender, nodose, 5. second metasomal tergite with small punctures, 6. mesopleuron with anterodorsal region impunctate and the posteroventral region coarsely punctate, 7. tibial spurs 1-2-2, 8. plumose setae distinct, and 9. head in dorsal outline somewhat transversely subrectangular. Wing venation also is similar between *Acrophotopsis* and *Dilophotopsis*. Similarities 1-3 appear to be synapomorphies for a clade including these genera. The wing venation may also support the monophyly of *Dilophotopsis* and *Acrophotopsis*, but a more thorough evaluation of the wing venation in other sphaerophthalmine genera is necessary.

In addition, Schuster (1958) stated that *Acrophotopsis* differs from *Dilophotopsis* by having an unarmed mesosternum, parameres that overlap *in situ*, distinct ventral felt lines and a modified mentum. However, the genitalia of *A. bergi* are similar to those of *Dilophotopsis* spp. in that the parameres do not overlap *in situ* (Casal 1967). Also, the cuspidis of *A. bergi* are elbowed as in *Dilophotopsis*. A further complication of Schuster's comparison of *Acrophotopsis* and *Dilophotopsis* is that some specimens of *D. stenognatha* have distinct sternal felt lines. Thus, with the addition of *A. bergi* and a closer inspection of the two genera, some of Schuster's (1958) diagnostic characters are no longer valid.

The only characters currently separating *Acrophotopsis* and *Dilophotopsis* are the presence of the mesosternal processes in

*Dilophotopsis* and the presence of a triangular carina on the mentum of *Acrophotopsis*. The occurrence of mesosternal processes also varies intergenerically in other Sphaerophthalmini. Many genera of Sphaerophthalmini in the southwestern United States are differentiated by this character in conjunction with other characters. Modification of the mentum into an anterior tubercle or posterior lingulate process has otherwise only been used, in part, to separate the subgenera of *Photomorphus* Viereck.

With the lack of robust generic-level characteristics distinguishing *Acrophotopsis* from *Dilophotopsis*, we believe that these two genera may be synonymous. However, synonymy of these two genera would be premature without a phylogenetic hypothesis of the subtribe Sphaerophthalmina. Although phylogenetic hypotheses for the subfamilies of Mutillidae exist (Brothers 1975, 1999, Lelej and Nemkov 1997), there is no hypothesis available for this subtribe. More informative characters could be added when the females of *Acrophotopsis* are described. For now, existing data and information are used to present the following new and revised diagnoses and keys for *Acrophotopsis*.

#### MATERIALS AND TERMINOLOGY

The following acronyms are used for institutions or collections housing the material discussed in the current study: The Bohart Museum of Entomology, University of California, Davis, California (UCDC); Canadian National Collection of Insects, Ottawa, Canada (CNCI); Cornell University Insect Collection, Department of Entomology, Cornell University, Ithaca, New York (CUIC); Department of Entomology, California Academy of Sciences, San Francisco, California (CASC); Department of Entomology Collection, University of Arizona, Tucson, Arizona (UAIC); Insect Collection, Los Angeles County Museum of Natural History, Los Angeles, California (LACM); James P. Pitts Collection, Athens, Georgia

(JPPC); United States National Museum, Smithsonian Institute, Washington D. C. (USNM); University of Minnesota Insect Collection, Department of Entomology, St. Paul, Minnesota (UMSP); UCR Entomological Teaching and Research Collection, University of California, Riverside, California (UCRC).

We use the following notation for punctures in the order of increasing size, depth, and their proximity: fine, small, moderate, coarse, and reticulate after Ferguson (1967). Fine refers to shallow punctures that have slanted or curved walls and are separated by greater than  $10\times$  their width (Fig. 1). Small refers to punctures that have slanted walls and are separated by  $2\text{--}10\times$  their width. Moderate refers to punctures that are separated by  $0.5\text{--}2\times$  the width of the puncture, with curved to vertical walls and punctures that tend to be circular (Fig. 11, mesonotum medially). Coarse refers to punctures that are closely spaced ( $0.2\text{--}0.5\times$  puncture width) with vertical walls and punctures are usually circular (Fig. 11, pronotum). Reticulate refers to sculpturing that resembles a network of lines with the punctures closely spaced (distance between punctures  $<0.2\times$  puncture width) with vertical walls. The punctures of reticulate sculpturing are not necessarily circular. In some cases (e.g., Fig. 3), punctures are elliptical, not circular, and may not be complete. For these irregularly shaped punctures, measurements are made using the maximum transverse width of the puncture. The term "micropunctate" refers to punctures that are extremely shallow and do not have vertical walls or sharp margins. We use the term "simple setae" for hairs that are smooth and do not have barbed surfaces. "Brachyplumose setae" refers to hairs with barbs that are less than, or equal to, the width of the shaft at the attachment of the barb. The term "plumose setae" is used for hairs that have longer barbs. We follow the terminology suggested by Menke (1993) for the scutum

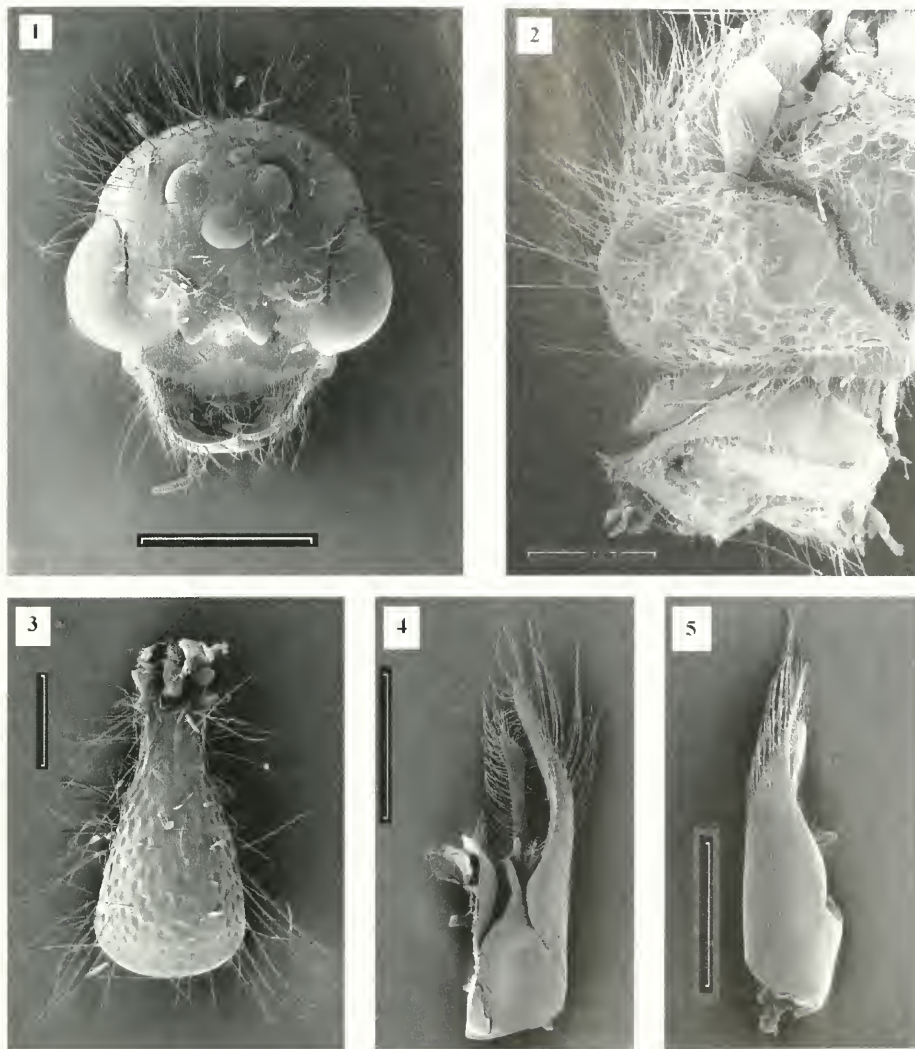

Figs. 1-5. Paratype: *Acrophotopsis mickeli*. 1, Head, anterior view, scale 1.0 mm. 2, Prothorax, lateral view, scale 0.5 mm. 3, Petiole, dorsal view, scale 0.5 mm. 4, Genital capsule, lateral view. 5, Genital capsule, dorsal view, scale 0.5 mm.

rather than that of Schuster (1958). The term "tibial spurs" is used instead of "calcaria." T2, T3, etc., denotes the second, third, etc., metasomal tergites, respectively. Similarly, S2, S3, etc., signifies the second, third, etc., metasomal sternites, respectively.

*Acrophotopsis mickeli* Pitts, new species  
(Figs. 1-5)

*Male holotype*.—Length: 11 mm. *Coloration*: Head and mesosoma reddish-brown,

metasoma darker. Integument reddish-brown under T2 felt line. Ocellular triangle dark brown and integument around and under felt lines of T2 and S2 dark brown. Antenna dark yellow. Frons, vertex, mesosoma, coxa, trochanter, and femur with sparse, white, erect, brachyplumose setae. Mandibles, apical margin of clypeal lobe, tibia, and tarsus with golden, erect, brachyplumose setae. Clypeus with short white brachyplumose setae on lateral margins. Legs yellow, femur dark-

ened apically. Apical margins of tergites and sternites with sparse, white, decumbent, plumose setae. Wings hyaline with golden setae. Pterostigma and veins yellowish brown. *Head*: width 2.2 mm, posterior margin rounded (Fig. 1). Punctures fine, not deep, widely separated (Fig. 1). Compound eyes protruding, maximum diameter 0.9 mm (Fig. 1). Median ocellus 0.4 mm, lateral ocellus 0.3 mm, ocellular distance 0.4 mm, and interocellar distance 0.4 mm; ommatidia apparent (Fig. 1). Malar space very short, 0.1 mm long. Antennal scrobe with inconspicuous carina present dorsally, becoming absent halfway between compound eye and antennal tubercle (Fig. 1). Small tubercles present halfway between compound eye and antennal tubercle, slightly ventral to carina (Fig. 1). Antennal scrobe glabrous (Fig. 1). Antennal tubercles glabrous and impunctate (Fig. 1). Clypeus slightly concave; median lobe projecting, slightly concave distally with a thick up-turned margin (Fig. 1). Clypeus glabrous, except median lobe with fine punctures apically (Fig. 1). Mandible with three apical teeth and one large basal tooth; basal width of mandible 0.4 mm, width of mandible at basal tooth 0.4 mm, width of mandible at preceding sinus 0.3 mm, apical width of mandible 0.5 mm. Scape with ventral carina. Length of scape, pedicel and first three flagellomeres: 0.8, 0.2, 0.3, 0.4 and 0.4 mm, respectively; width of first flagellomere 0.2 mm. *Mesosoma*: Pronotum, scutum and scutellum coarsely punctate (Fig. 2). Pronotal epaulets present (Fig. 2). Parapsidial furrows present on posterior three-fourths of scutum. Propodeum reticulate, reticulations broader anteriorly. Propleuron (Fig. 2) and mesopleuron moderately punctate, punctures of mesopleuron broader than those of propleuron. Metapleuron glabrous and impunctate. Prosternum with fine punctures. Mesosternum unarmed, with moderate punctures. Legs with femora finely punctate. Prothoracic tibia with fine punctures. Meso- and metathoracic tibiae with

small punctures. Tibial comb curving away from leg apically. Internal tibial spur of mesothoracic leg curving toward leg. Wings with pterostigma 0.9 mm long measured along costa. Marginal cell 1.2 mm long. Second submarginal cell pentagonal, 0.9 mm long. *Metasoma*: Petiolate. T1 nodose. Punctures of segment 1 moderate. Punctures of segments 2–6 fine. T7 micropunctate with glabrous, impunctate, margin. S7 broadly emarginate, with fine punctures towards margin. Length of T2 felt line equal to approximately 3× length of S2 felt line. *Genitalia*: Parameres arcuate, stout at base and slightly flattened toward apex, tapering, slightly inwardly and dorsally curved, with long setae present on outer margin (Figs. 4, 5). Cuspis elongate, not reaching to apex of paramere, straight with apical portion slightly dilated, basal portion cylindrical, distal portion and inner margin with long setae, dorsomedial area sparsely and minutely pubescent (Fig. 5). Digitus cylindrical and minutely pubescent (Figs. 4, 5).

*Female*.—Unknown

*Host*.—Unknown

*Type material*.—Holotype ♂, Mexico, Baja California Sur, 6 mi. SW Santiago, 31.VIII.1959, Light Trap, K.W. Radford & F.G. Werner (CASC); Paratypes, 11♂, same data as holotype (UAIC, CASC, JPPC).

*Other material examined*.—MEXICO, Baja California Norte: 1♂, 17 mi S Ensenada, 14.VI.1938, M. Bacher & E. Ross (USNM); Baja California Sur: 1♂, Agua Caliente, Cape Region, Hwy Sur, 18.X.1941, E. Ross & R.M. Bohart (CASC); 1♂, 2 mi N Cabo San Lucas, Hwy Sur, 16.I.1959, H.B. Leech (CASC); 1♂, 20 mi N Comundo, 23.VII.1938, M. Bacher & E. Ross (USNM); 25 mi. W La Paz, 37♂, 30.VIII.1959, 12♂, 4.IX.1959, K.W. Radford & F.G. Werner (UAIC); 1♂, 20 mi NW La Paz, 16.VII.1938, M. Bacher & E. Ross (USNM); 1♂, Las Animas, Sierra Laguna, 18.X.1941, E. Ross & R.M. Bohart (CASC); 1♂, 6 mi S Mirallores, 18.I.1959, H.B. Leech (CASC); 1♂, San Bar-

tolo, 13.VII.1938, Bacher & E. Ross (CASC); 1♂, San Ignacio, 4 mi. W, 26.VIII.1959, K.W. Radford & F.G. Werner (UAIC); 1♂, 15 mi N San Ignacio, 24.VI.1938, M. Bacher & E. Ross (USNM); 4♂, 10 mi. SW San Jose del Cabo, 1.IX.1959, Light Trap, K.W. Radford & F.G. Werner (UAIC); 1♂, 2 km W San Jose del Cabo, 30.VI.1982, W. N. Cross (JPPC); 2♂, 7 mi N Santa Anita, Hwy Sur, 7.I.1959, H.B. Leech (CASC); 2♂, Santiago, 8.VII.1938, M. Bacher & E. Ross (USNM); 3♂, San Venancio, 8.X.1941, E. Ross & R.M. Bohart (CASC); 8♂, Todos Santos, 10.X.1941, E. Ross & R.M. Bohart (CASC); 5♂, 4 mi. N Todos Santos, 2.IX.1959, K.W. Radford & F.G. Werner (UAIC); 6♂, Triunfo, 13.VII.1938, M. Bacher & E. Ross (USNM); 1♂, 6 mi N, 15.VII.1938, M. Bacher & E. Ross (USNM).

*Variation.*—Total body length 8.2–11.5 mm; head width 1.81–2.30 mm; compound eyes, maximum diameter 0.68–0.96 mm; median ocellus 0.25–0.38 mm; lateral ocellus 0.23–0.32 mm; ocellocular distance 0.30–0.42 mm; interocellar distance 0.33–0.41 mm; malar space 0.08–0.12 mm. Color variation exists among some of the specimens in that some have a lighter T2 than the holotype and have the apical third of the middle femur only slightly darkened. However, all have the integument beneath the felt lines darkened and the apical third of the hind femur darkened.

*Etymology.*—Named for one of the most notable students of Mutillidae, Clarence E. Mickel.

*Comments.*—*Acrophotopsis mickeli* differs from *A. campylognatha* by being smaller, having the distal third of the middle, and hind femora darkened and having the metasoma darkened, at least under the felt lines. The anterior half of the mesopleuron of *A. campylognatha* is impunctate and polished, whereas the mesopleuron of *A. mickeli* has punctures that gradually deepen posteriorly and is only impunctate on the anterior fourth. *Acrophotopsis mickeli* differs from *A. eurygnatha* by being slightly larger, having the distal third of middle

and hind femora darkened and having a larger ventral tooth on the mandible (width of mandible at excision approximately equal to depth of excision, not distinctly greater than the depth of excision as in *A. eurygnatha*). The wing venation is similar for all four species (as in Fig. 10).

The genitalia of *A. mickeli* (Figs. 4, 5) most closely resemble those of *A. campylognatha* (Figs. 15, 16). The genitalia of *Acrophotopsis mickeli*, however, differ from those of *A. campylognatha* by having slightly longer cuspidis and thinner parameres.

### *Acrophotopsis bergi* Casal (Figs. 6–9)

*Acrophotopsis bergi* Casal 1967:2, ♂. Type data: Mexico, Morelos, 3 mi N of Alpuyecá, at light, 3.XII.1959, H.E. Evans and D.M. Anderson (CUIC).

*Diagnosis.*—*Acrophotopsis bergi* is highly autapomorphic. It differs from all congeners by having a transverse furrow between epaulets of the pronotum (Fig. 6), and by having the cuspidis elbowed (Figs. 8, 9) and bearing four broad, distally curved spines on the internal boarder, as well as smaller, distally curved, spines, basal to the 4 larger spines (Figs. 8, 9). Also, the parameres of *A. bergi* do not overlap *in situ* as with the other species of *Acrophotopsis* (Casal 1967).

*Other material examined.*—MEXICO, 1♂, Puebla, Izúcar de Matamoros, 1.VIII.1968, F.D. Parker & L.A. Stange (JPPC).

*Distribution.*—From the limited number of known specimens, this species occurs in regions south of Mexico City, Mexico, in the states of Morelos and Puebla.

*Remarks.*—The new specimen does not significantly differ from the holotype.

### *Acrophotopsis campylognatha* Schuster (Figs. 15–16)

*Acrophotopsis campylognathus* Schuster 1958:69, ♂. Type data: Mexico, Baja California, Arroyo Rosarito, 29.III.1935, C.M. Brown (CASC).

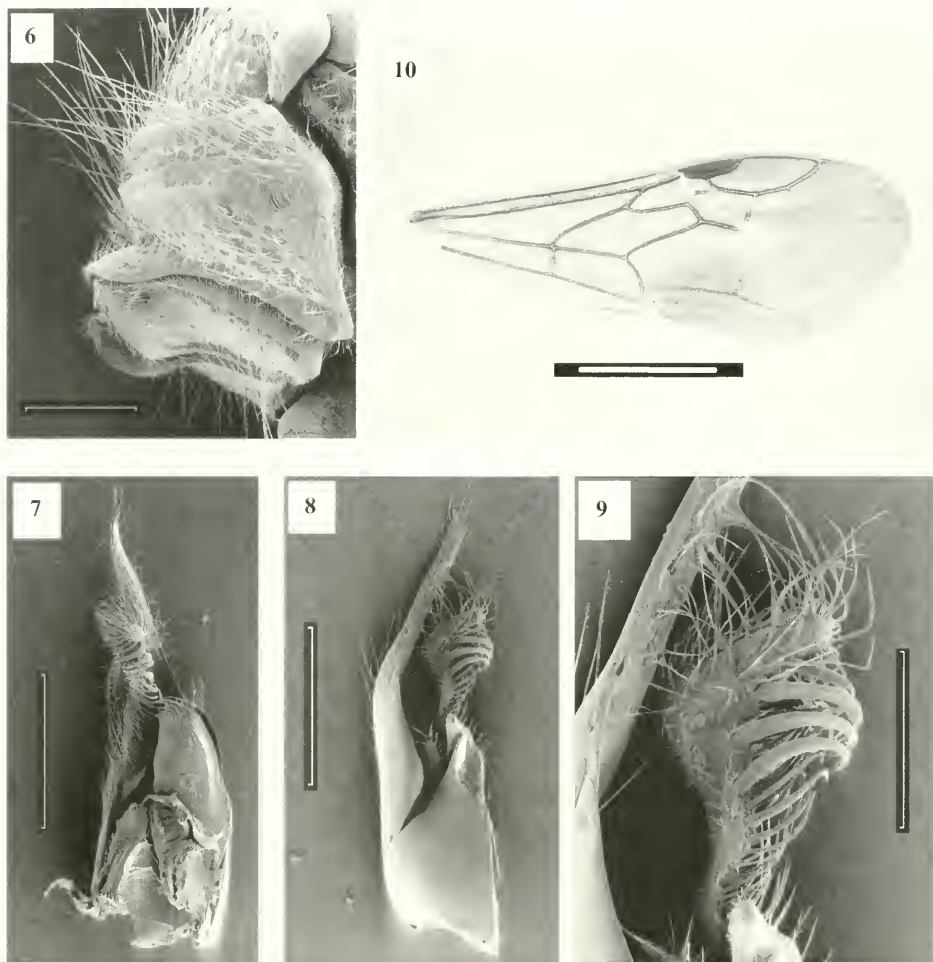

Figs. 6-10. *Acrophotopsis* species. 6-9. *A. bergi*. 6, Prothorax lateral view, scale 0.5 mm. 7, Genital capsule, mesal view. 8, Genital capsule, ventral view; scale 0.5 mm. 9, Cuspis, ventral view, scale 0.2 mm. 10. *A. curygnatha*, wing, scale 2 mm.

*Diagnosis.*—*Acrophotopsis campylognatha* is the largest species of *Acrophotopsis*. The metasoma is concolorous with the head and mesosoma and the integument is not darkened under felt lines. The anterodorsal half of the mesopleuron is glabrous. The genitalia of *Acrophotopsis campylognatha* (Figs. 15, 16) are similar to those of *A. mickeli* (Figs. 4, 5) but differ by having slightly shorter cuspis and thinner parameres that are straight.

*Other material examined.*—USA, California, Riverside Co.: Deep Canyon, 1♂, 2.V.1963, P.M. Estes (UMSP); 1♂,

30.V.1963, 1♂, 13.VI.1963, E.I. Schlinger (UCRC); Palm Springs, 1♂, 23.V.1917 (CASC); 1♂, Tahquitz Canyon, 8.VI.1957, Menke, Stange, & Bromley (LACM). MEXICO, Baja California Norte: 3♂, Arroyo Rosarito, 27.III.1935, C.M. Brown (UMSP); Catarina, 1♂, 114° 40', 29° 45', 3.IV.1935, G.W. Harbinson (UMSP); 5♂, 15 mi. N El Refugio, 4.VII.1938, M. Bacher & E. Ross (CASC); 3♂, Ensenada, Las Animas Cañon, 27.VI.1925, W.S. Wright (UMSP); 7♂, 17 mi S Ensenada, 14.VI.1938, M. Bacher & E. Ross (CASC); 2♂, 15 mi N Punta Prieta, 29.VII.1938, M. Bacher & E. Ross

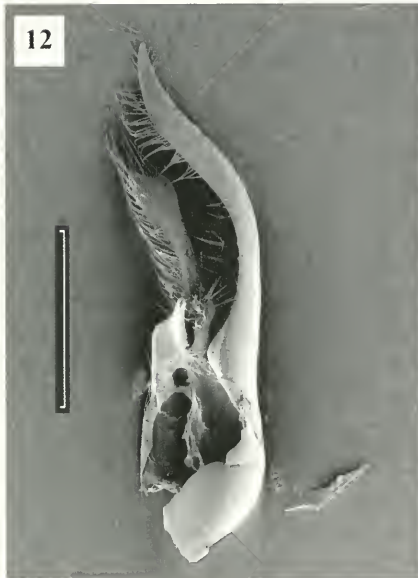
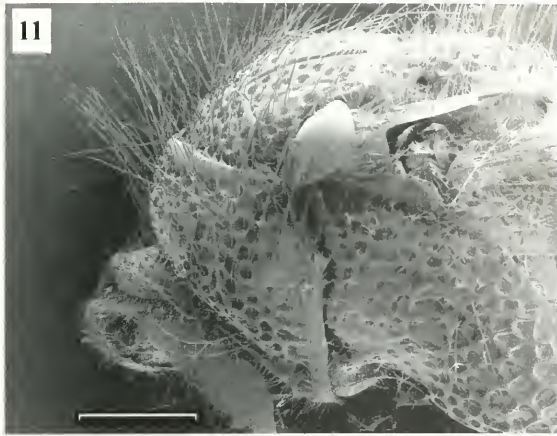

Figs. 11-14. *Acrophotopsis curygnatha*, 11, Prothorax, lateral view, scale 0.5 mm. 12, Genital capsule, ventral view, scale 0.5 mm. 13, Genital capsule, dorsal, scale 0.5 mm. 14, Cuspis, dorsal view, scale 0.2 mm.

(CASC); 1♂, San Vicente, 14.V.1939, C.E. Norland (LACM); 1♂, San Venecio, 8.X.1941, E. Ross & R.M. Bohart (CASC); Baja California Sur: 1♂, 10 mi NE Cabo San Lucas, Hwy Sur, 17.I.1959, H.B. Leech (CASC); 5♂, 10 mi S Catavina, 29.VII.1938, M. Bacher & E. Ross (CASC); 2♂, 1 mi NE El Cien, 31.III.1975, M. Odano (LACM); 4♂, 10 mi E Mesquitil, 23.VI.1938, M.

Bacher & E. Ross (CASC); 2♂, Miraflores, 8.VII.1938, M. Bacher & E. Ross (USNM); 2♂, 19 mi F Rosario, 17.VI.1938, M. Bacher & E. Ross (CASC); 2♂, 10 mi N San Ignacio, 24.VI.1938, M. Bacher & E. Ross (CASC); 2♂, 15 mi N San Ignacio, 24.VI.1938, M. Bacher & E. Ross (USNM); 1♂, 12 mi S Santa Rosalia, 27.VI.1938, M. Bacher & E. Ross (CASC); 1♂, Todos San-

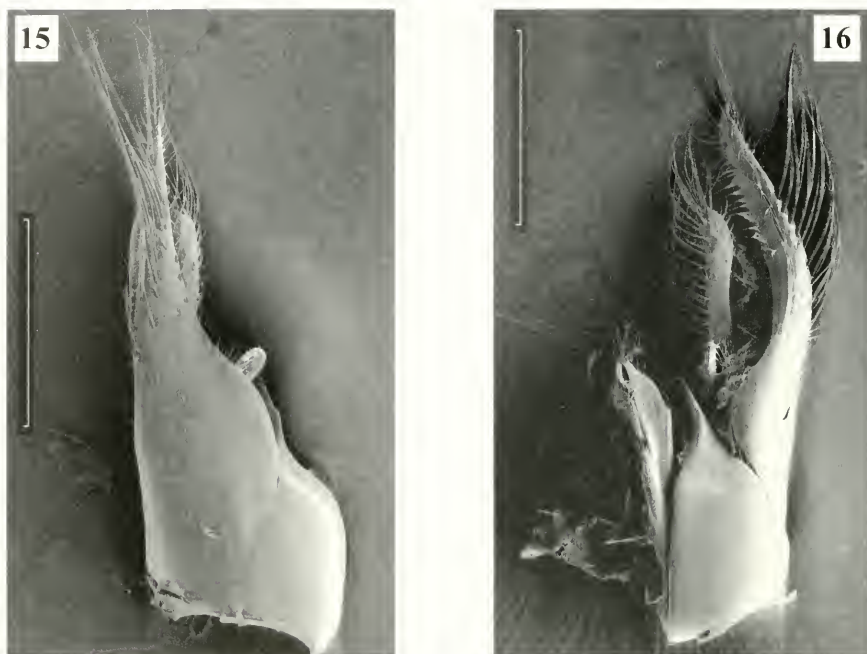

Figs. 15-16. *Acrophotopsis campylognatha*, genital capsule. 15, Lateral view. 16, Dorsal view, scale 0.5 mm.

tos, 10.X.1941, E. Ross & R.M. Bohart (CASC); 2♂, Triunfo, 13.VII.1938, M. Bacher & E. Ross (CASC); Baja California (?), 1♂, Hamilton Ranch, 2.VIII.1938, M. Bacher & E. Ross (USNM); 1♂, El Arco Mine, 14 mi S, 23.VI.1938, M. Bacher & E. Ross (USNM).

*Distribution*.—*Acrophotopsis campylognatha* is present in the southern regions of the Mojave Desert of California and into the Sonoran Desert of Baja California, Mexico.

*Remarks*.—Sixteen specimens were found that were labeled as paratypes by Schuster. Because these specimens were not published in Schuster (1958), they cannot be considered paratypes and have been included here in the material examined.

*Acrophotopsis eurygnatha* Schuster  
(Figs. 10-14)

*Acrophotopsis eurygnathus* Schuster 1958:65, ♂.  
Type data: USA, Arizona, Gila Co., Globe, 8.VII.1949, Werner & Nutting (CASC).

*Diagnosis*.—This species is highly autapomorphic. Its genitalia differs from all congeners by the presence of thick, flattened parameres and stout cuspidis (Figs. 12-14). The apices of the cuspidis are armed with straight, stout spines and the internal boarder of the cuspidis are armed with short, stout, ventrally curving spines, as well as being sparsely clothed with setae (Figs. 13, 14). The punctuation of the mesosoma (Fig. 11) tends to be deeper and denser than the other species (Figs. 2, 6). Also, the metasoma is darker than the head and mesosoma or the integument of the mesosoma is at least darkened under felt lines. The mesopleuron is glabrous anteriorly for approximately  $\frac{1}{4}$  its length.

*Type material*.—Paratypes: USA, Arizona, Pima Co., Quitjotoa, 3♂, 27-28.VIII.1928, J.C. Bradley (CUIC).

*Other material examined*.—USA, Arizona, Gila Co.: 1♂, 6 mi. E. Rte 288, nr. Cherry Creek, at Light, 19.V.1950 (CUIC); Globe, 1♂, 12.V.1934, F.H. Parker (UMSP); 1♂, 9.VI.1936, F.H. Parker (UMSP); 2♂,

13.VI.1938, D.K. Duncan (UMSP); 1♂, 15.VI.1938, D.K. Duncan (UMSP); 2♂, 20.VI.1936, F.H. Parker (UMSP); 1♂, 25.VI.1938, D.K. Duncan (UMSP); 1♂, 30.VI.1937; 1♂, 13.VII.1936; 1♂, 5.VIII.1937; 2♂, 8.VIII.1933; 2♂, 19.VIII.1935; 1♂, 22.VIII.1937; 1♂, 26.VIII.1937, F.H. Parker (UMSP); 2♂, Globe, Parker Ranch, Six-Shooter Cyn., 22.VIII.1952, H.B. Leech & J.W. Green (CASC); Globe, Pinal Creek, 1♂, 6.VI.1953, 2♂, 7.VI.1959, 1♂, 7.VI.1963, A. & H. Dietrich (CUIC); 1♂, Gila Head, 25.VIII.1935, F.H. Parker (UMSP); Cochise Co.: Cochise Stronghold, Dragoon Mts., 1♂, 17–21.V.1970, 1♂, 15–20.VI.1970, R.J. Share (UAIC); 1♂, Huachuaca Mnts, Sierra Vista, 18.III.1963, Sternitsky (CNCI); Portal, 1♂, 22.VIII.1959, 4♂, 5.IX.1959, H.E. Evans (CUIC); 1♂, 1 mile S Portal, 4.VI.1965, Davidson, Davidson, & Cazier (LACM); 1♂, Willcox, 9–10.VIII.1970, S. Kozloski (UAIC); 3♂, Coconino Co., 23.VIII.1940, F.W. Nunenmecher (UMSP); 1♂, Graham Co., Bonita Creek, 17.VIII.1976, D.S. Chandler (UAIC); Maricopa Co.: 1♂, Agua Fria, 26.VIII.1937, D.H. Duncan (UMSP); 1♂, Gila Bend, 25.VIII.1935, F.H. Parker (UMSP); Pima Co.: Baboquivari Mts., 1♂, 27.IV.1947, A.L. Melander (UCRC), 2♂, 7.VI.1924, C.C. Poling (CASC); 4♂, Baboquivari Mts., Baboquivari Cyn., West Side, 25–27.VII.1952, Leech & Green (CASC); Baboquivari Mts., Brown Cyn., 1♂, 7.IX.1958, L. Martin (LACM); 1♂, 29–30.VII.1952, Leech & Green (CASC); 1♂, Continental, 27.VII, W.J. Chamberlin (UMSP); 3♂, 5mi E. Continental, 29.VIII.1959, H.E. Evans (CUIC); Tucson, 1♂, 3.V.1963, C.E. Mickel (LACM), 2♂, 6.V.1963, C.E. Mickel (UMSP), 1♂, 9.V.1962, C.E. Mickel (LACM); 1♂, 1.VI.1933, 1♂, 1.VI.1935, 1♂, VIII, 52♂, 1.VIII.1939, 1♂, 10.IX.1935, 6♂, 20.IX.1935, D. Bryant (UMSP); 1♂, 11.VIII.1924, E.P. Van Duzee (CASC), 1♂, 20.VII.1935, D. Bryant (CASC); 1♂, 24.V.1920, F.X. Williams (CASC); 1♂, 10.VIII.1939, R.H. Crandall (UMSP); 2♂, Catalina foot-hills, N end Campell Ave., 5.VIII.1967, Noller; Saguaro Nat. Mon., 1♂, 8.V.1962, 1♂, 18.V.1960, 1♂, 30.VI.1961, G.

Butler (LACM); 3♂, Santa Catalina Mts., 26.VI.1933, Bryant (UMSP); 22♂, Santa Catalina Mts., west slope Pusch Peak, 17.V.1963, C.E. Mickel (UMSP); 1♂, Sycamore Cyn. nr. Rugby, 22.V.1954, S. Selgimar (LACM); Santa Rita Mts., Madera Cyn., 1♂, 20–27.VII.1940, 1♂, 1.VIII.1947, 1♂, 14.VIII.1949, 1♂, 23.VIII.1948, L. Martin (LACM); 2♂, 30.VII.1955, F.X. Williams (CASC); Pinal Co.: 1♂, Irene Wash, 24.V.1963, C.E. Mickel (UMSP); 1♂, Oracle, 28.VI.1924, J.O. Martin (CASC); 1♂, Picacho Peak, 11.VIII.1965 (UCRC); 1♂, Superstition Mts., 16.VII.1943, R.Q. Flock (UCRC); 1♂, Santa Cruz Co., Tumacacori, 27.VIII.1975 (UAIC); Santa Cruz Co.: 1♂, Patagonia, VII.1937, E. Ross (CASC); Yavapai Co.: 1♂, 9.VIII.1962, F. Werner & J. Bequaert (LACM); 1♂, Congress, 19.VII.1939, N. Stagger (UMSP); 1♂, Skull Valley, 31.VII.1970, J.E. May (UAIC); Yuma Co., 1♂, Yuma, 1907 (UCRC); California, Riverside Co., 10♂, Palm Springs, 6.VI.1932 (UMSP); San Bernardino Co., 1♂, Apple Valley, 2.V.1955, Harwick (CNCI); San Bernardino Co., 3♂, Yermo, 16.V.1919, W.M. Pearce (UMSP). MEXICO: 1♂, Sinoloa, N Rio Fuerte Hwy, 13.VI.1965, E. M. Fisher (LACM); 1♂, Sonora, 16mi NE. Ciudad Obregón, 13–17.V.1961, Howden & Martin (CNCI); 1♂, Islas Tres Marías, Isle María Madre, village, 21.V.1925, H.H. Keifer (CASC).

*Distribution.*—*Acrophotopsis eurygnatha* occurs in the Mojave Desert of Nevada to the Sonoran Desert of Arizona and Mexico. The new locality data from the Isle María Madre in the Islas Tres Marías, provides a considerable range extension. Only one specimen was seen from this region and it did not differ significantly from typical *A. eurygnatha*. However, due to its disjunct distribution from the rest of *A. eurygnatha*, only careful examination of more specimens from this same region can verify whether it is truly *A. eurygnatha* or a undescribed species.

*Remarks.*—Schuster (1958) designated a holotype and 16 paratypes for *A. eurygnatha*. Thirteen additional specimens

(USNM) are labeled as paratypes by Schuster. These specimens are not among the designated paratypes and are not conspecific with *A. eurygnatha*. In actuality, they are *A. mickeli* and have been included in the other material examined for that species. As with *A. campylognatha*, there may be many more specimens labeled as paratypes. Some of them might also be *A. mickeli*.

---

KEY TO SPECIES OF *ACROPHOTOPSIS* (MALES)

- 1 Pronotum with transverse furrow between epaulets (Fig. 6); cuspis elbowed, with four broad, distally curved spines on internal boarder (Figs. 7–9) ..... *bergi* Casal  
 – Pronotum without transverse furrow between epaulets (Figs. 2, 11); cuspis straight with normal setae (Figs. 4, 5, 12–16) ..... 2  
 2 (1) Second metasomal segment brownish-red to dark brown, at least under felt lines, not concolorous with head and mesosoma ..... 3  
 – Entire metasoma concolorous with head and mesosoma, not darkened under felt lines ..... *campylognatha* Schuster  
 3 (2) Cuspis stout, length of visible portion not more than 6× width (Figs. 12, 13); apex of cuspis armed with several straight spines and internal boarder of cuspis armed with row of shorter, curved spines (Figs. 13,14); parameres stout, length of not more than 8× width (Figs. 12, 13); width of mandible at excision distinctly greater than the depth of excision; legs entirely yellowish ..... *eurygnatha* Schuster  
 – Cuspis thin, length of visible portion greater than 8× width (Figs. 4, 5); apex and internal boarder of cuspis not armed with spines, clothed only with setae (Fig. 4); parameres thin, length equal to or more than 10× width (Figs. 4, 5); width of mandible at excision equal to depth of excision; hind femora and usually distal third of middle femora darkened ..... *mickeli* Pitts, n. sp.
- 

ACKNOWLEDGMENTS

We thank E. H. Tilgner (University of Georgia, Athens) and T. L. Pitts-Singer (University of Georgia, Athens) for critically reviewing drafts of this paper; W. Pulawski (CASC), T. R. Schultz (USNM), L. S. Kimsey (UCDC), R. R. Snelling (LACM), J. T. Huber (CNCI), E. R. Hoebeke (CUIC) and C. A. Olson (UAIC) for loans of the specimens; P. J. Clausen (UMSP) for loaning specimens and C. E. Mickel's notes; K. V. Krombein (USNM) and W. Pulawski (CASC) for answering questions concerning this project. We are thankful for the assistance provided by M. A. Farmer and J. A. Shields of the Center of Ultrastructural Studies, University of Georgia. The following institutions provided support to JPP for this study: the CNCI for a CanaColl grant allowing JPP to travel to the CNCI, Ottawa, Canada in 1999 and American Museum of Natural History for the Theodore Roosevelt Memorial Fund for travel to the Southwestern Research Station (SWRS), Portal, Arizona during 2000. We thank Wade Sherbrooke for his hospitality and help during JPP's stay at the SWRS. We are also grateful for the financial support provided by the University of Georgia, Department of Entomology.

LITERATURE CITED

- Brothers, D. J. 1975. Phylogeny and classification of the aculeate Hymenoptera, with special reference to Mutillidae. *University of Kansas Science Bulletin* 50: 483–648.  
 Brothers, D. J. 1999. Phylogeny and evolution of wasps, ants, and bees (Hymenoptera, Chrysidoidea, Vespoidea, and Apoidea). *Zoologica Scripta* 28: 233–249.  
 Casal, O. H. 1967. Comentarios sobre *Acrophotopsis* Schuster, con la descripción de una nueva especie de México (Hymenoptera: Mutillidae). *Physis* 74: 1–4.  
 Ferguson, W. E. 1963. Note on the behavior of male nocturnal mutillid wasps. *Pan-Pacific Entomologist* 39: 65–66.  
 Ferguson, W. E. 1967. Male sphaerophthalmine mutillid wasps of the Nevada Test Site. *Brigham Young University Science Bulletin, Biological Series* 8: 1–26.  
 I.C.Z.N. 1999. *International Code of Zoological Nomenclature*, Fourth Edition, Adopted by the International Union of Biological Sciences. International

- Trust for Zoological Nomenclature, London XXIX +306 pp.
- Lelej, A. S. and P. G. Nemkov. 1997. Phylogeny, evolution and classification of Mutillidae (Hymenoptera). *Far Eastern Entomologist* 46: 1-24.
- Menke, A. S. 1993. Notauli and parapsidial lines: just what are they? *Sphecos* 24: 9-11.
- Schuster, R. M. 1958. A revision of the sphaerophthalmine Mutillidae of America north of Mexico. II. *Entomologica Americana* 37: 1-130.

## RAPD Linkage Map of *Melipona quadrifasciata anthidioides* Lepeletier (Hymenoptera: Apidae: Meliponini)

MARA GARCIA TAVARES, LUCIO ANTONIO DE OLIVEIRA CAMPOS,  
EVERALDO GONÇALVES DE BARROS, AND MARIA TERCILIA VILELA DE AZEREDO OLIVEIRA  
(MGT, LAOC, EGB) Departamento de Biologia Geral, Universidade Federal de Viçosa. Av. PH  
Rolf, s/n, 36.571-000, Viçosa, MG, Brasil, MGT email: mtavares@mail.ufv.br;  
(MTVAO) Departamento de Biologia, Instituto de Biociências, Letras e Ciências Exatas de São  
José do Rio Preto (IBILCE/UNESP).R: Cristovão Colombo, 2265, 15.054-000,  
São José do Rio Preto, SP, Brasil

---

*Abstract.*—We present the first linkage map for a stingless bee—*Melipona quadrifasciata* Lepeletier. The linkage map was constructed on 60 haploid drones from a single queen using 127 RAPD (Randomly Amplified Polymorphic DNA) markers. Eighty-nine of these markers mapped on 22 linkage groups. The remaining 38 markers were unlinked. The 22 linkage groups spanned over 1,416 cM, with an average marker density of  $21.3 \pm 6.9$  cM (mean  $\pm$  SD). Our data demonstrated that the recombination frequency of *M. quadrifasciata* differs significantly from that of *A. mellifera* Linnaeus. Comparisons of the genetic and social structure of *M. quadrifasciata* and *A. mellifera*, however, show that, besides the level of sociality, there are some particular life history traits that could be causing the specific recombination frequencies observed. It is expected that this map will substantially accelerate molecular genetic analysis of *M. quadrifasciata* and help to explain the observed variation in recombination frequency within Hymenoptera.

---

Like most hymenopteran species, sex in stingless bees is determined by haplodiploidy, a genetic system under which ordinary males are haploid and females are diploid. Diploid males, however, have been detected in approximately 40 species of Hymenoptera (Cook 1993, Carvalho et al. 1995, Crozier and Pamilo 1996, Holloway et al. 1999, Noda 2000). Experimental evidence based on the offspring of sibling matings demonstrated that a single locus multiple-allele system of sex determination (CSD) is operating in these species (Whiting 1943, Woyke 1963, Smith and Wallace 1971, Camargo 1979, Ross and Fletcher 1985, Naito and Suzuki 1991, Periquet et al. 1993, Beye and Moritz 1994, Butcher et al. 2000).

Presently, *A. mellifera* Linnaeus is the hymenopteran species best studied for sex determination. Two molecular markers are closely linked to sex locus (locus X) in

this species: a RAPD marker called locus Q (Hunt and Page 1994) and a fingerprinting multilocus marker, locus Z (Beye and Moritz 1994). As predicted by the single locus multiple-allele system (Whiting 1943) these markers are in homozygose in diploid drones and in heterozygose in females, proving that only one locus is involved in the sex determination of *A. mellifera*.

The molecular genetic mechanism that triggers CSD, however, has yet to be identified (Stouthamer et al. 1992, Cook 1993, Beukeboom 1995, Cook and Crozier 1995). Nonetheless, elucidation of the genes responsible for such events requires knowledge of the genetic organization of organisms that exhibit CSD, and their linkage mapping is obviously the initial step.

Genetic linkage maps have been reported for only eight Hymenoptera species: *Nasonia vitripennis* (Walker) (Saul 1993,

Gadua et al. 1999), *Aphelinus asychis* Walker (Kazmer et al. 1995), *Apis mellifera* Linnaeus (Hunt and Page 1995), *Bracon hebetor* Say (Antolin et al. 1996), *Trichogramma brassicae* Bezdenko (Laurent et al. 1998), *Bracon* sp. near *hebetor* (Holloway et al. 2000), *Athalia rosae* Jakovlev (Nishimori et al. 2000) and *Bombus terrestris* Linnaeus (Gadua et al. 2000), of which CSD is found in *A. mellifera*, *A. rosae*, *B. hebetor* and *B. sp.* near *hebetor*.

Despite the ecological and economic importance of bees, *A. mellifera* is the only highly eusocial bee that has been genetically mapped. No genetic maps have yet been built for *Melipona quadrifasciata* Lepelletier, a stingless bee species, popularly known in Brazil as "mandacaia". Like most hymenopteran species, *M. quadrifasciata* exhibits parthenogenesis to generate haploid males from non-fertilized eggs. This reproductive pattern facilitates the development of genetic maps as the analysis of haploid males supplies the information about heterozygous loci present in the parental female. Thus, the present work aims to construct a linkage map for *M. quadrifasciata* using RAPD markers to provide a basis for further research on the genetics of hymenopteran species that exhibit CSD.

## MATERIAL AND METHODS

*Genetic material.*—A virgin queen of *Melipona quadrifasciata* was crossed with a drone that had been previously sterilized by treatment with gamma-ray irradiation (60,000r) emitted by a cobalt-60 pump. The queen was maintained in Petri dishes together with young workers, and after 10 days this queen was introduced into an intermediary colony until she was physogastric and then she was transferred to a colony from which the original queen had been removed. After oviposition, combs with progeny were withdrawn from the colony and progeny were allowed to emerge in an incubator at 28°C. As in colonies of *M. quadrifasciata* some drones can

be the result of eggs laid by unrelated worker bees. The drones that originated from this cross were checked for the presence of non maternal bands, and sixty drones (F1 progeny) that were progeny of this queen were used as the mapping population. Each individual was frozen in liquid nitrogen and immediately separated into two parts—head and metasoma, and mesosoma. The head and metasomas were used for DNA extraction.

*DNA extraction and PCR reactions.*—The genomic DNA was extracted as described by Waldschmidt et al. (1997a). The amplification reaction mixture (25  $\mu$ l) contained 3.5 mM MgCl<sub>2</sub>, 10 mM/50 mM Tris-KCl (pH 8.3), 0.1 mM of each dNTP (dATP, dTTP, dGTP, dCTP), 0.4  $\mu$ M of a decamer primer (Operon Technologies, Alameda, CA, USA), one unit of Taq DNA polymerase and 25 ng of genomic DNA. The mixture was placed in a thermocycler model PTC-100 (MJ Research) programmed for 40 cycles. Each cycle consisted of 15 seconds at 94°C, 30 seconds at 35°C and 1 min at 72°C. After the 40th cycle a final extension step of 7 min at 72°C was performed.

*Gel electrophoresis and scoring.*—The amplification products were resolved in 1.2% agarose gels immersed in TBE (90 mM Tris-borate, 10 mM EDTA), stained with ethidium bromide (10  $\mu$ g/ml), visualized and documented under UV light. Each set of PCR reactions was checked for contamination by the use of a negative control (no DNA). Preliminary tests (not shown) defined 79 primers to be used in the RAPD analyses. These primers produced consistent bands that could be easily scored.

*Linkage analyses.*—The polymorphic bands detected in this population were tested for the 1:1 segregation ratio using Chi-square analysis. Markers presenting a significant deviation ( $p < 0.05$ ) from the expected ratio were not included in the linkage analyses. The analyses were performed with the Mapmaker/EXP 3.0 (Lander et al. 1987), using the backcross settings. Due to the absence of phase in-

formation of each marker the following strategy was used (Dr. Mark J. Daly, personal communication): each polymorphic marker was coded as "H" for band present and "A" for band absent and then the code was altered from "H" to "A" and "A" to "H", respectively. In this way, Mapmaker created two linkage groups for each chromosome. One linkage group from each pair was selected for further analyses.

The linkage groups were determined using the "group" command with a LOD score of 3.0 and a maximum recombination fraction of 0.4. The order of the markers within each linkage group was established through multiple point analysis using the "compare" command. The genetic distances, expressed in cM, were calculated using the Kosambi mapping function (Kosambi 1944).

Genome size estimates were calculated using a method to compare insaturated maps (Gadau et al. 1999), where the linked markers of *M. quadrifasciata* were randomized and linkage maps of 20, 40, 60 and 80 markers were calculated. For every set of markers, the total map size was the size of each linkage group plus an added 40 cM for all unlinked markers.

## RESULTS AND DISCUSSION

The amplification of genomic DNA from haploid drones of *M. quadrifasciata* with 79 selected primers generated 133 polymorphic bands. Six markers that deviated from the expected 1:1 ratio were not considered in subsequent analyses. Therefore, 127 markers were used to generate the linkage map. Eighty-nine of these markers were distributed along 22 linkage groups, ranging from 211.1 to 11.1 cM, and 38 markers were unlinked. The 22 linkage groups spanned over 1,416 cM, with an average marker distance of  $21.3 \pm 6.9$  cM (mean  $\pm$  SD). Seventeen of the 22 linkage groups contained three or more markers, and the other five only two markers each (Fig. 1).

It is clear that the present map underestimates the complete recombinational length of the *M. quadrifasciata* genome because the haploid chromosome number of this species is  $n = 9$  and we found 22 linkage groups. Further analyses, increasing the number of primers and drones (sons of different queens), will be necessary to fill in the gaps allowing the saturation of the present map.

The accuracy of a genetic map is directly related to the coverage of the genome achieved and the reliability of the genetic markers employed. The first issue was only partially attained as our map is still very incomplete. As for the markers used, RAPD markers can be quite reliable. For instance, inheritance studies in *A. mellifera* (Hunt and Page 1992) and in *M. quadrifasciata* (Tavares et al. 2001) using RAPD markers also demonstrated that these markers are reliably inherited and during the construction of the present linkage map, most of the RAPD markers (95.5%) segregated 1:1 in a progeny of haploid drones demonstrating the utility of these markers for linkage analysis.

Most of the linkage maps built for the Hymenoptera species, however, are not saturated. The genetic map of *A. mellifera* ( $n = 16$ ) based on the segregation of 365 RAPD markers, showed 26 linkage groups (Hunt and Page 1995). RAPD-SSCP analyses in *Bracon hebetor* ( $n = 10$ ) positioned 79 RAPD markers in 13 linkage groups and five markers were unlinked (Antolin et al. 1996) and in *B. sp.* near *hebetor*, 71 markers were included in 10 linkage groups, but 9 markers were still unlinked (Holloway et al. 2000). The composite map of *Trichogramma brassicae* ( $n = 5$ ) has 84 RAPD markers organized in five linkage groups and 11 unlinked markers (Laurent et al. 1998). In the interespecific *Nasonia* ( $n = 5$ ) map, 91 markers could be mapped into five linkage groups that spanned over 764.5cM, while 14 markers showed no linkage relationship to any group (Gadau et al. 1999). The *Athalia rosae* ( $n = 8$ ) ge-

nome was also mapped with RAPD markers, generating a linkage map with 16 linkage groups and 10 unlinked loci (Nishimori et al. 2000).

An estimate of the total size of the map, however, is useful to determine the relationship between genetic and physical distances. In an absence of the estimates of actual map sizes, Gadau et al. (1999) proposed a method to compare unsaturated map size based on the number of markers for the different species. According to this method, relative map sizes are constructed with equal number of markers and then their sizes are compared. Such comparisons have shown that the estimated map size of *M. quadrifasciata* (1,355.8 cM/80 markers) lies within the size limits obtained for other Hymenoptera species: *Nasonia* (829cM/80 markers), *T. brassicae* (1,330 cM/84 markers), *B. hebetor* (1,156 cM/79 markers), *Bombus terrestris* (1,091 cM/80 markers) and *A. mellifera* (2,020 cM/80 markers) (Gadau et al. 2000).

As map distances are based on recombination fractions, these comparisons also indicate that the recombination frequency of *M. quadrifasciata* is lower than that of *A. mellifera*, which until now has presented the highest meiotic recombination rate of any higher eukaryote (Hunt and Page 1995). These authors suggested that the extremely high recombination rate of *A. mellifera* was associated with male haploidy in Hymenoptera. But, as stated by Gadau et al. (2000), Hymenoptera contain both very large and very small genome maps which contradict this hypothesis.

This difference in recombination frequency between *M. quadrifasciata* ( $n = 9$ ) and *A. mellifera* ( $n = 16$ ), two eusocial Hymenoptera species, can be explained, in part, by differences in their number of chromosomes. This observation is consistent with results showing that most species have a number of two to three cross-overs per bivalent, regardless of the chromosome size (Hunt and Page 1995). So an increased recombination rate is expected

in species that have greater chromosome number.

This correlation, however, is not found when we compare the map size of *M. quadrifasciata* with that of another eusocial Hymenoptera, *B. terrestris* ( $n = 18$ ), nor with other hymenopteran species. For instance, species so different in relation to chromosome number as *T. brassicae* ( $n = 5$ ), *B. hebetor* ( $n = 10$ ) and *B. terrestris* ( $n = 18$ ) have approximately the same genome size, while species with the same haploid chromosomal number as *Nasonia* and *T. brassicae*, have genetic maps of 829cM and 1,330cM, respectively (Gadau et al. 2000). It seems, therefore, that mechanisms other than variation in chromosome number may be generating different recombination rates in Hymenoptera.

Gadau et al. (2000) proposed that highly eusocial hymenopteran species with large colonies and a clear division of labor should have higher recombination frequencies than their closely related but socially less developed relatives. Our data, however, shows that the recombination frequency of *M. quadrifasciata*, a highly eusocial stingless bee that poses a well defined system of labor division, differs significantly from that of *A. mellifera* and is closer to that of *B. terrestris*, a primitively eusocial bee. Comparisons in the genetic and social structure of *M. quadrifasciata* and *A. mellifera*, however, show that, besides the level of sociality, there are some particular life history traits that could be causing the specific recombination frequencies observed. The *M. quadrifasciata* colonies, for instance, are much smaller than those of *A. mellifera*, ranging from 500 to 1,500 individuals and contrary to *A. mellifera*, its labor division system is not genetically determined (Waldschmidt et al. 1997b), which could contribute to the differences observed. Conclusive comparisons, however, in order to obtain detailed explanations for variation in recombination frequencies within the Hymenoptera, and corroborate Gadau's hypothesis, re-

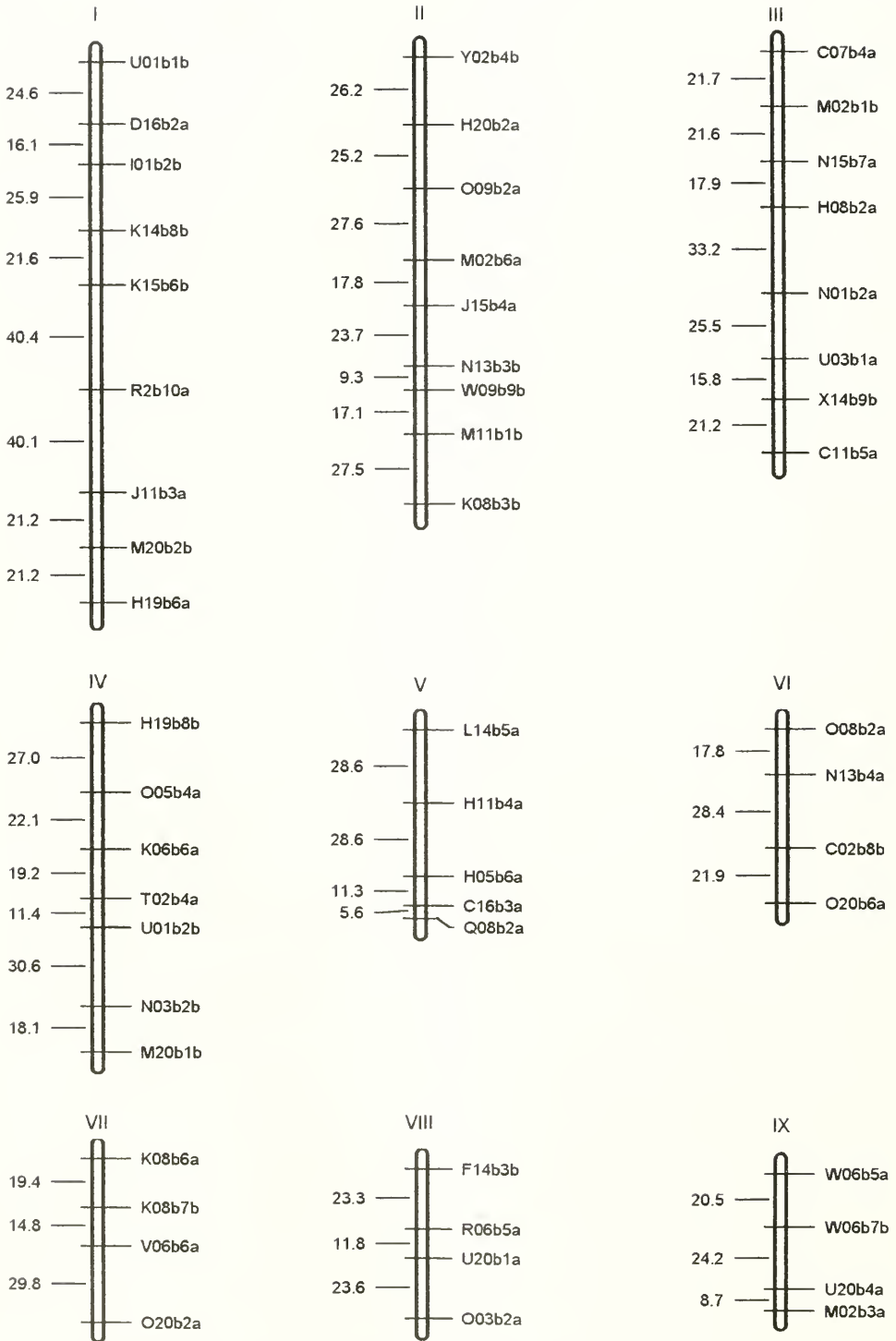

Fig. 1. Genetic linkage map of *Melipona quadrifasciata* based on RAPD markers. Identification of markers is given on the right of the corresponding linkage group. Genetic distances in cM are given on the left side of each linkage group.

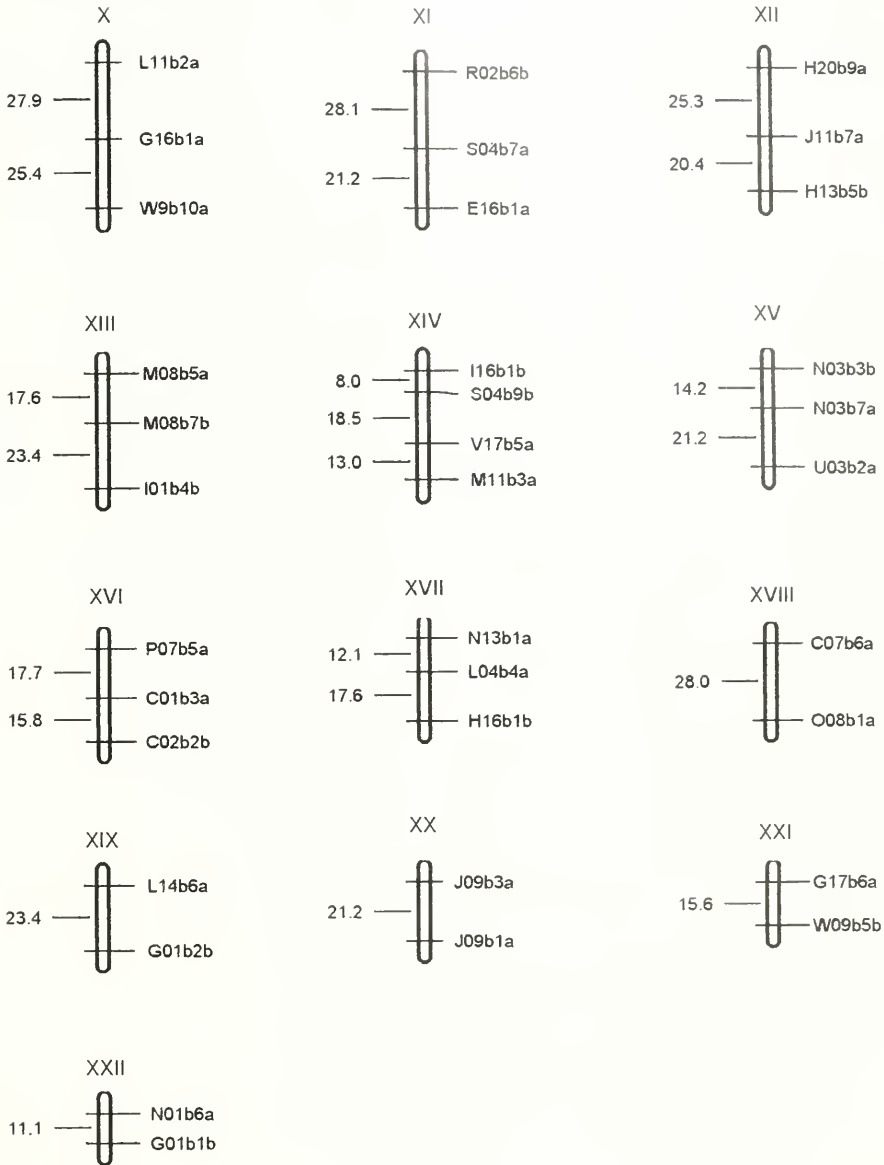

Fig. 1. continued.

quire the study of the genome of a greater number of highly eusocial hymenopteran species.

The present map represents, definitely, an initial step for future genetic analyses of the *M. quadrifasciata* genome. Our efforts are now concentrated on the saturation of the map with RAPDs as well as other types of markers so it can be used

to map characters of interest such as the locus involved with sex determination in *M. quadrifasciata*.

ACKNOWLEDGMENTS

We are grateful to Dr. M. A. Del Lama (Departamento de Genética e Evolução—UFSCar, São Carlos) for suggestions and assistance. The help of Dr. M. J. Daly, (Whitehead Institute for Biomedical Research,

Cambridge, USA), and Dr. R. X. Côrreia (Departamento de Biologia—UESC, Ilhéus), in computer analysis and understanding Mapmaker is gratefully acknowledged. We are also grateful to CNEN/CDTN (Comissão Nacional de Energia Nuclear/Centro de Desenvolvimento da Tecnologia Nuclear) for irradiation support. This research was supported by CNPq (Conselho Nacional de Desenvolvimento Científico e Tecnológico) and FAPEMIG (Fundação de Amparo à Pesquisa de Minas Gerais).

## LITERATURE CITED

- Antolin, M. F., C. F. Bosio, J. Cotton, W. Sweeney, M. R. Strand, and W. C. Black IV. 1996. Intensive linkage mapping in a wasp (*Bracon hebetor*) and a mosquito (*Aedes aegypti*) using single-strand conformation polymorphism analysis of random amplified polymorphic DNA markers. *Genetics* 143: 1727–1738.
- Beukeboom, L. W. 1995. Sex determination in Hymenoptera: a need for genetic and molecular studies. *BioEssays* 17: 813–817.
- Beye, M. and R. F. A. Moritz. 1994. Sex linkage in the honeybee *Apis mellifera* detected by multilocus DNA fingerprinting. *Naturwissenschaften* 81: 460–462.
- Butcher, R. D. J., W. G. F. Whitfield and S. F. Hubbard. 2000. Single-locus complementary sex determination in *Diadegma chrysostictos* (Gmelin) (Hymenoptera: Ichneumonidae). *The Journal of Heredity* 91(2): 104–111.
- Camargo, C. A. 1979. Sex determination in Bees. XI Production of diploid males and sex determination in *Melipona quadrifasciata*. *Journal of Apicultural Research* 18: 77–83.
- Carvalho, G. A., W. E. Kerr and V. A. Nascimento. 1995. Sex determination in bees. XXXIII. Decrease of  $x_0$  heteroalleles in a finite population of *Melipona scutellaris* (Apidae, Meliponini). *Brazilian Journal of Genetics* 18: 13–16.
- Cook, J. M. 1993. Sex determination in the Hymenoptera: a review of models and evidence. *Heredity* 7: 421–435.
- Cook, J. M. and R. H. Crozier. 1995. Sex determination and population biology in the Hymenoptera. *Trends in Ecology and Evolution* 10: 281–286.
- Crozier, R. S. and P. Pamilo. 1996. *Evolution of social insects colonies. Sex allocation and kin selection*. Oxford University Press, New York.
- Gadau, J., R. E. Page Jr. and J. H. Werren. 1999. Mapping of hybrid incompatibility loci in *Nasonia*. *Genetics* 153: 1731–1741.
- Gadau, J., R. E. Page Jr, J. H. Werren and P. Schmid-Hempel. 2000. Genome organization and social evolution in Hymenoptera. *Naturwissenschaften* 87: 87–89.
- Holloway, A. K., G. E. Heimpel, M. R. Strand and M. F. Antolin. 1999. Survival of diploid males in *Bracon* sp. Near *hebetor* (Hymenoptera: Braconidae). *Annals of the Entomological Society of America* 92: 110–116.
- Holloway, A. K., M. R. Strand, W. C. Black IV and M. F. Antolin. 2000. Linkage analysis of sex determination in *Bracon* sp Near *hebetor* (Hymenoptera: Braconidae). *Genetics* 154: 205–212.
- Hunt, G. J. and R. E. Page. 1992. Patterns of inheritance with RAPD molecular markers reveal novel types of polymorphisms in the honey bee. *Theoretical and Applied Genetics* 85: 15–20.
- Hunt, G. J. and R. E. Page. 1994. Linkage analysis of sex determination in the honey bee (*Apis mellifera*). *Molecular Genes and Genetics* 244: 512–518.
- Hunt, G. J. and R. E. Page. 1995. Linkage map of the honey bee, *Apis mellifera*, based on RAPD markers. *Genetics* 139: 1371–1382.
- Kazmer, D. J., K. R. Hopper, D. M. Coutinot, and D. G. Heckel. 1995. Suitability of random amplified polymorphic DNA for genetic markers in the aphid parasitoid, *Aphelinus asychis* Walker. *Biological Control* 5: 503–512.
- Kosambi, D. D. 1944. The estimation of map distances from recombination values. *Annual Eugenics* 12: 172–175.
- Lander, E., P. Green, J. Abrahamson, A. Barlon, M. Daley, S. Lincoln and L. Newburg. 1987. MAP-MAKER: an interactive computer package for constructing primary genetic linkage maps of experimental and natural populations. *Genomics* 1: 174–181.
- Laurent, V., E. Wajnberg, B. Mangin, T. Schiex, C. Gaspin and F. Vanlerberghe-Masutti. 1998. A composite genetic map of the parasitoid wasp *Trichogramma brassicae* based on RAPD markers. *Genetics* 150: 275–282.
- Naito, T. and H. Suzuki. 1991. Sex determination in the sawfly, *Athalia rosae ruficornis* (Hymenoptera): occurrence of triploid males. *The Journal of Heredity* 82: 101–104.
- Nishimori, Y., J. M. Lee, M. Sumitani, M. Hatakeyama and K. Oishi. 2000. A linkage map of the turnip sawfly *Athalia rosae* (Hymenoptera: Symphyta) based on random amplified polymorphic DNAs. *Gene and Genetic Systems* 75: 159–166.
- Noda, T. 2000. Detection of diploid males and estimation of sex determination system in the parasitic wasp *Diadegma semiclausum* (Hellen) (Hymenoptera: Ichneumonidae) using an allozyme as a genetic marker. *Applied Entomological and Zoology* 35: 41–44.
- Periquet, G., M. P. Hedderwick, M. El Agoze and M. Poirié. 1993. Sex determination in the hymenopter *Diadromus pulchellus* (Ichneumonidae): validation of the one-locus multi-allele model. *Heredity* 70: 420–427.
- Ross, K. G. and D. J. Fletcher. 1985. Genetic origin of male diploidy in the fire ant, *Solenopsis invicta*

- (Hymenoptera: Formicidae) and its evolutionary significance. *Evolution* 39: 888–903.
- Saul, G. B. 1993. Gene map of the parasitic wasp *Nasonia vitripennis* (*Mormoniella vitripennis*)  $2n = 10$ . In: *Genetic Maps*, 6th ed. (ed.: S. O'Brien), pp. 3.277–3.280. Cold Spring harbor Laboratory Press, New York.
- Smith, S. G. and D. R. Wallace. 1971. Allelic Sex determination in a lower Hymenopteran, *Neodiprion nigroscutum*. *Cancer Journal of Genetics and Cytology*
- Stouthamer, R., R. F. Luck and J. H. Werren. 1992. Genetics of sex determination and the improvement of biological control using parasitoids. *Environmental Entomology* 21: 427–435.
- Tavares, M. G., E. H. Ribeiro, L. A. O. Campos, E. G. Barros and M. T. V. A. Oliveira. 2001. Inheritance pattern of RAPD markers in *Melipona quadrifasciata* (Hymenoptera: Apidae, Meliponinae). *Journal of Heredity* 92(3): 279–282.
- Waldschmidt A. M., T. M. F. Salomão, E. G. Barros and L. A. O. Campos. 1997a. Extraction of genomic DNA from *Melipona quadrifasciata* (Hymenoptera: Apidae, Meliponinae). *Brazilian Journal of Genetics* 20: 421–423.
- Waldschmidt, A. M., L. A. O. Campos and P. De Marco. 1997b. Genetic variability of behavior in *Melipona quadrifasciata* (Hymenoptera: Meliponinae). *Brazilian Journal of Genetics* 20(4): 595–599.
- Whiting, P. W. 1943. Multiple alleles in complementary sex determination of *Habrobracon*. *Genetics* 28: 365–382.
- Woyke, J. 1963. Drone larvae from fertilized eggs of the honeybee. *Journal of Apicultural Research* 2(1): 19–24.

## Polydnaviruses in the Genus *Mirax* Haliday (Hymenoptera: Braconidae)

R. A. WHARTON AND H. SITTERTZ-BHATKAR

(RAW) Department of Entomology, Texas A&M University, College Station, TX 77843, USA,  
email: rawbaw2@tamu.edu; (HS-B) Microscopy and Imaging Center, Texas A&M University,  
College Station, TX 77843, USA

---

*Abstract.*—Polydnaviruses are reported from the genus *Mirax* Haliday, representing the first record of these viruses from the braconid subfamily Miracinae. The polydnaviruses of *Mirax* replicate in the calyx region of the female reproductive tract, as in the subfamily Microgastrinae. The somewhat rod-shaped virions contain multiple inclusions.

---

The abrogation of the host immune system by endoparasitic Hymenoptera has been the subject of considerable interest in recent decades, largely as a result of the pioneering work by George Salt (1968). Polydnaviruses are key factors in the equation for a select groups of parasitoids, and are now accorded family rank in viral classification (Stoltz et al. 1984). Polydnaviruses replicate in a specialized calyx tissue at the base of the lateral oviduct in female wasps and are expressed in the host following injection during oviposition. Excellent reviews are available, both technical and for general audiences, on their structure and function (Edson et al. 1981, Whitfield 1990, Krell 1991, Fleming 1992, Stoltz 1993, Dib-Hajj et al. 1993, Strand and Pech 1995, Beckage 1997, Webb 1998).

Polydnaviruses have been recorded from a number of species in the families Ichneumonidae and Braconidae but, within these families, their distribution is fairly limited (Stoltz and Whitfield 1992). The species containing polydnaviruses represent derived groups within their respective families. The morphology of the virus differs in the two families and this, together with molecular differences, has led to the designation of ichneumonid polydna-

viruses as ichnoviruses and braconid polydnaviruses as bracoviruses (Fleming 1992). Within the Braconidae, polydnaviruses were initially known only from the subfamilies Microgastrinae, Cardiochilinae, and Cheloninae (Stoltz and Vinson 1979, Krell 1991, Stoltz and Whitfield 1992). Studies by Whitfield (1997) suggest a single origin of the polydnaviruses in braconid wasps, supporting predictions (Stoltz and Whitfield 1992, Wharton 1993) that this group of viruses is common to the microgastroid lineage. Here we report the presence of polydnaviruses in *Mirax* Haliday, a genus usually accorded separate subfamily rank (Miracinae: van Achterberg 1993) and placed near the Microgastrinae (Whitfield and Mason 1994, Whitfield 1997).

### MATERIAL AND METHODS

An apparently undescribed species in the genus *Mirax* was collected with a sweep net in a mixed pine-deciduous woodland in Jones State Forest, Montgomery County, Texas. Live specimens were taken to the laboratory where they were chilled and provisionally identified under a dissecting microscope by the senior author. The reproductive tract was then removed in insect saline and fixed

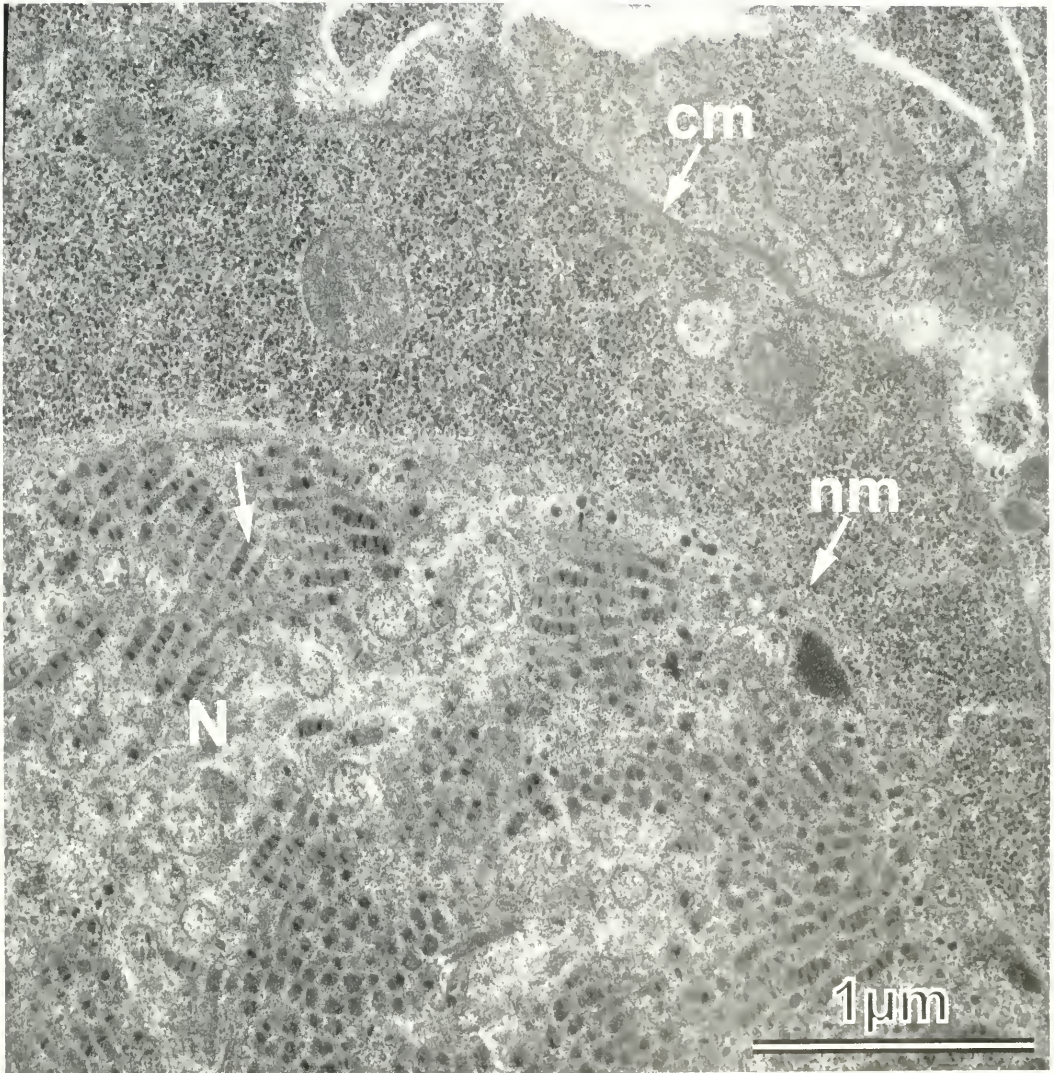
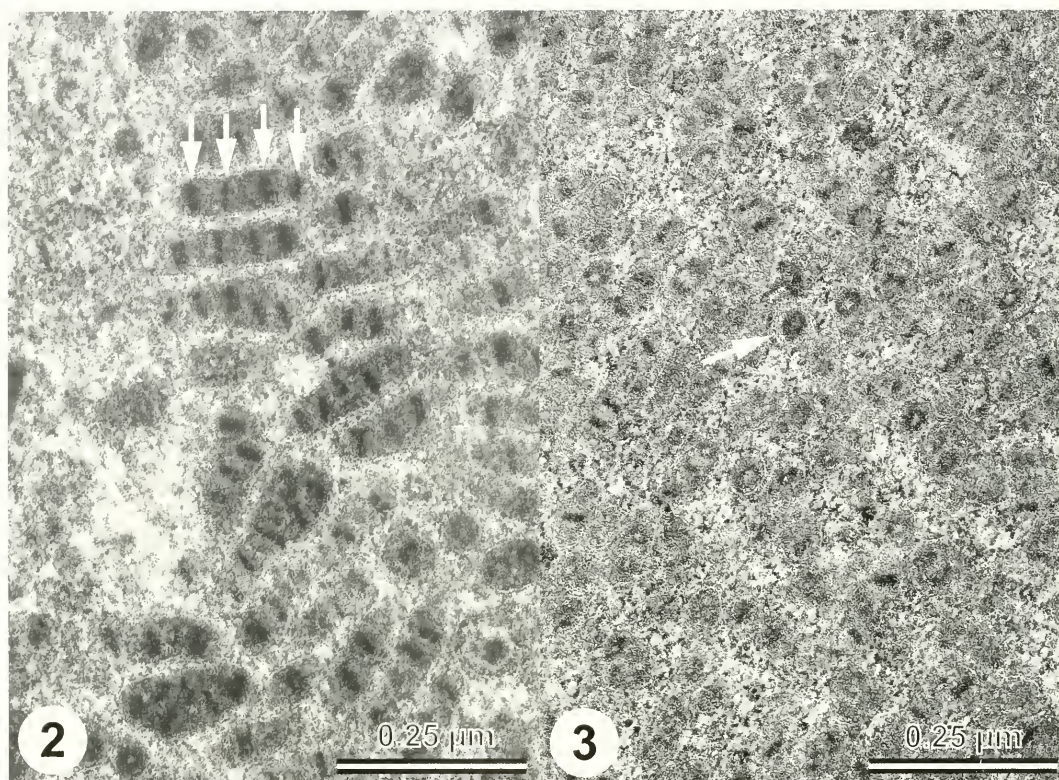

Fig. 1. Cell from calyx region of *Mirax* sp., showing fully formed polydnavirus virions packed into nucleus; N = nucleus, nm = nuclear membrane, cm = cell membrane, arrow = rod-shaped polydnavirus.

for 6 hours at RT in a mixture of 2% glutaraldehyde, 2% paraformaldehyde, 2% acrolein and 1.5% dimethyl sulfoxide (DMSO) in 0.133 M sodium cacodylate (pH 7.4) (modified from Kalt and Tandler 1971). After rinsing in 0.1 M sodium cacodylate, material was post fixed in 1% osmium tetroxide. Following fixation, dehydration and ethanol replacement with propylene oxide, samples were embedded in a mixture of Araldite and Embed

812 (Epon-812) embedding medium (Mollenhauer 1964). Material was sectioned with a diamond knife using an ultramicrotome from LKB (Ultratome type 4802A). Sections 70–90 nm thick were stained with 10% uranylacetate in 30% ethanol for 30 minutes followed by Reynolds' lead citrate for 10 minutes (Reynolds 1963). Sections were examined and photographed using a Zeiss 10C transmission microscope at 80 kV on Kodak



Figs. 2-3. Polydnviruses of *Mirax* sp. 2, Dense clusters of mostly rod-shaped virions showing stacked nature of nucleocapsids within each virion; arrows = 4 nucleocapsids within a single virion, in longitudinal section. 3, Detail of virions in longitudinal and cross sections; arrow = cross section.

Electron Microscope Film 4489 (ESTAR Thick Base).

Voucher specimens representing the wasp from which the ovaries were extracted and a conspecific, intact wasp collected from the same locality are deposited in the Texas A&M University Insect Collection as voucher specimen number 632.

### RESULTS

The reproductive tract in gross dissection is similar to that figured by Stoltz et al. (1976) for *Toxoneuron* (as *Cardiochiles*) *nigriceps* (Viereck): the section of the lateral oviduct adjacent to the compact ovaries is expanded into a distinct calyx. There is a very short, unexpanded distal portion of the lateral oviduct extending between the calyx and the common oviduct, as in *Chelonus insularis* Cresson (= *C.*

*texanus* Cresson) (Stoltz et al. 1976, Fig. 1). Presence of virus in the reproductive tract was suspected based on the bluish reflection observed with magnifications of 60-100 $\times$  under the dissecting microscope. Electron microscopy revealed that the presumptive polydnviruses of *Mirax* are formed in this well-defined calyx region of the oviduct, as they are in the Microgastrinae, Cheloninae, and Cardiochilinae (Stoltz et al. 1976).

Morphologically, the viruses found in *Mirax* are very similar to bracoviruses found in Microgastrinae (Stoltz and Vinson 1977, de Buron and Beckage 1992). As in other bracoviruses, the nucleocapsids are rod-shaped (Fig. 1) and the virion is enclosed in a single membrane (Fig. 3). Virions are somewhat variable in shape (Fig. 2), as in bracoviruses, though they often

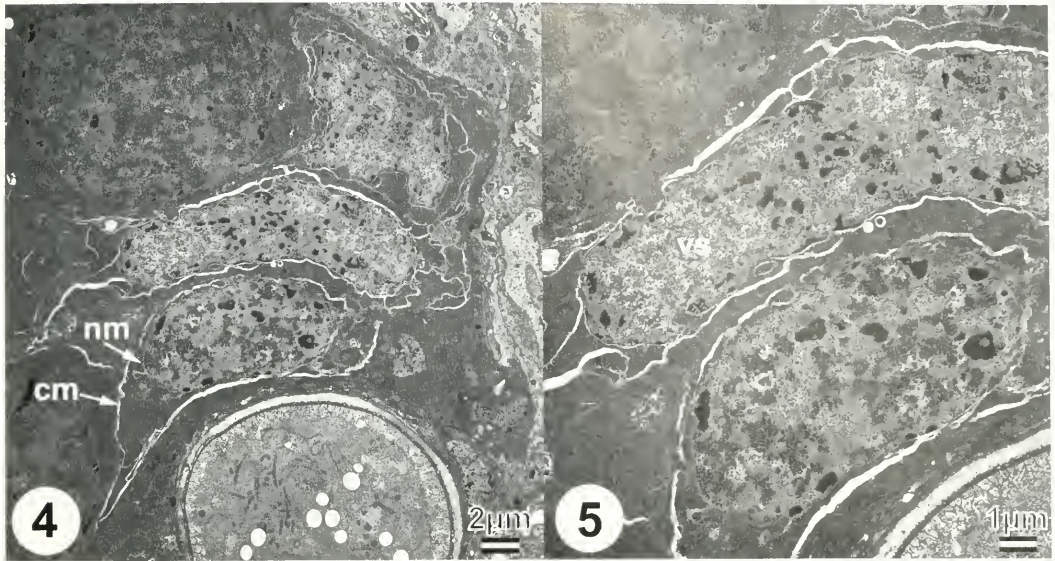

Figs. 4–5. Calyx cells showing early stages of viral infection. 4, Cells with differing amounts of viral stroma and well-formed virions; nm = nuclear membrane, cm = cell membrane. 5, Enlarged to show viral stroma (vs).

appear rod-shaped (approximately  $0.2\text{--}0.3\ \mu\text{m}$  in length  $\times$   $0.07\text{--}0.09\ \mu\text{m}$  in width) at lower magnifications (Fig. 1). Multiple nucleocapsids can be seen within each envelope (Figs. 1–2), a characteristic of some but not all bracoviruses. The nucleocapsids often appear stacked within the virus particles (Figs. 1–2). As is typical of polydnaviruses in general, formation of the viral stroma takes place in the nucleus (Figs. 4, 5), where discrete virions are eventually organized. The nucleus begins to fill with virions, and the nuclear membrane starts to break up (Figs. 6, 7). Long, thin cells full of microtubules are often seen in the vicinity of infected cells (Figs. 8, 9). Viral particles are ultimately emptied into the lumen of the lateral oviduct when the cell walls break and liberate their contents (Figs. 10–12). While we realize that molecular data are desirable for confirmation of the identity of these structures as polydnaviruses, we note that their formation and release from calyx cells (via lysis) is identical to that reported for other bracoviruses, and they replicate in a well-defined calyx region.

## DISCUSSION

Stoltz and Whitfield (1992) listed 29 species of braconid wasps, representing 13 genera and 3 subfamilies, in which polydnaviruses had been found. Several other species of braconids, primarily in the microgastrine genus *Cotesia* Cameron, have subsequently been examined and found to contain polydnaviruses (Whitfield 2000). In general, the viruses in these wasps conform morphologically to those shown here for *Mirax*. Polydnaviruses in braconid wasps have either single or multiple nucleocapsids per virion, with multiple nucleocapsids recorded for species now placed in the genera *Protapanteles* Ashmead, *Glyptapanteles* Ashmead and *Cotesia* (Stoltz and Vinson 1977, de Buron and Beckage 1992). In *Mirax*, the virions are more rod-shaped, and the nucleocapsids have a consistently stacked appearance relative to the generally more rounded virions of the microgastrines, in which the nucleocapsids are more scattered (de Buron and Beckage 1992, Fig. 6; Stoltz and Whitfield 1992, Fig. 1).

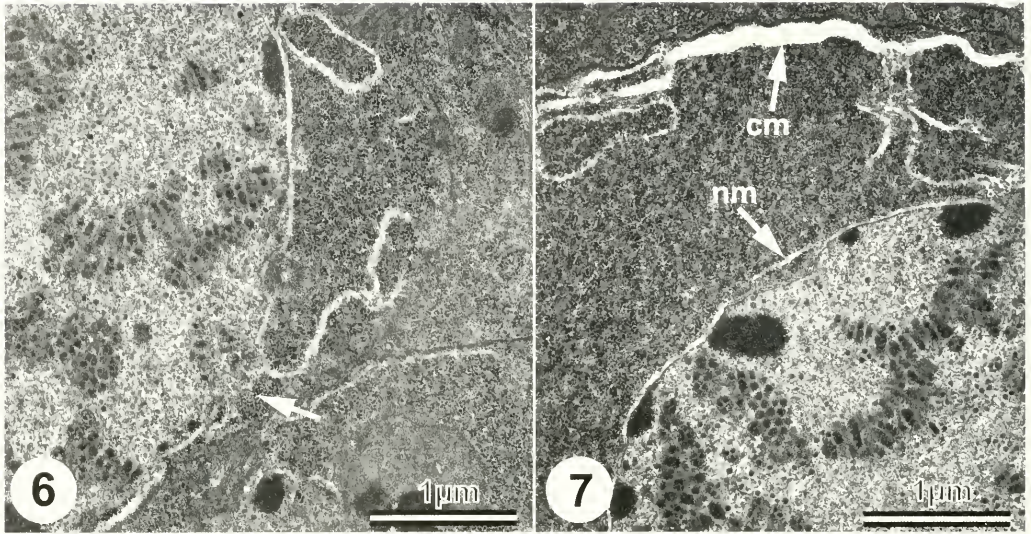

Figs. 6-7. Calyx cells filled with virus. 6, Arrow showing apparent disruption of portions of nuclear membrane. 7, Cell at similar stage of degradation; nm = nuclear membrane, cm = cell membrane.

An earlier report of polydnnaviruses in *Mirax* (Whitfield 1997: Table 1) was based on information provided to Whitfield by RAW for use in that report. The present report is therefore the first documented record of polydnnavirus-like particles in *Mirax*, and the first characterization of their

gross morphology. Predictions that other members of the microgastroid complex should contain polydnnaviruses (Stoltz and Whitfield 1992, Wharton 1993) are now confirmed, at least based on viral morphology and location of replication in the wasp's reproductive tract. This is not sur-

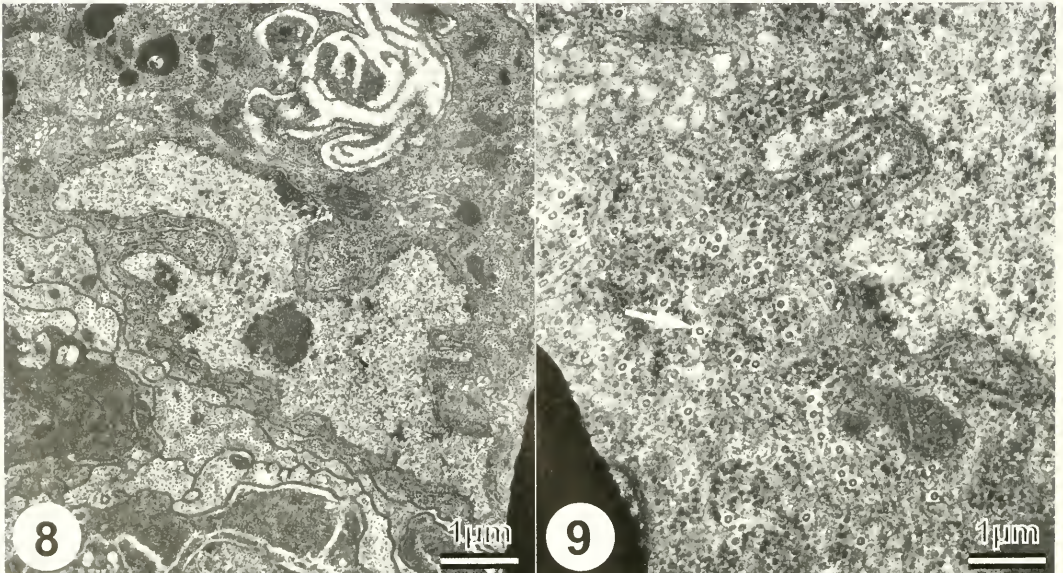

Figs. 8-9. 8, Thin cells filled with microtubules in vicinity of infected cells. 9, Detail, arrow = microtubules in cross section.

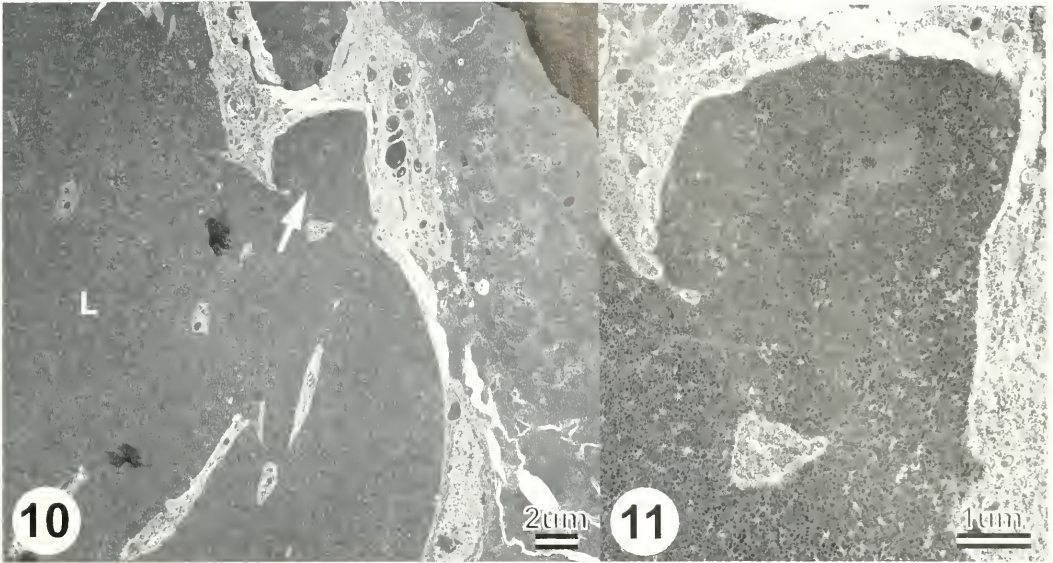

Figs. 10–11. Discharge of virions (and some cell fragments) into lumen of lateral oviduct in region of calyx. 10, Lumen (L) filled with virions and a single cell (arrow) releasing contents. 11, Detail of same cell.

prising given the repeated demonstrations of the close affinity of *Mirax* to the Microgastrinae (Muesebeck 1922, Nixon 1965, Mason 1981, Whitfield and Mason 1994).

Viruses (or virus-like particles) have been discovered in the reproductive tract of several other braconids, including those distinctly outside the microgastroid lineage. Most notable among these are the two

classes of viruses found by Lawrence and Akin (1990) in *Diachasma inorpha* (as *Bios-teres*) *longicaudata* (Ashmead), a member of the subfamily Opiinae, and the more recent report of virus-like particles somewhat resembling polydnnaviruses from the ovaries of *Microctonus aethiopooides* Loan, a member of the Euphorinae (Barratt et al. 1999). A distinct calyx region is absent in the reproductive tract of both of these wasps. Although the role of these other viruses in immunosuppression has not been fully explored, there is sufficient circumstantial evidence to suggest that polydnnaviruses may not be the only family of viruses involved in immune suppression in braconid wasps.

The specimen from which the reproductive tract was extracted for the figures shown here is similar to *Mirax texana* Muesebeck, but does not completely match the description of this species given by Muesebeck (1922). It is quite possible that this represents an undescribed species of *Mirax*, which is not surprising given the poor knowledge of this genus in North America.

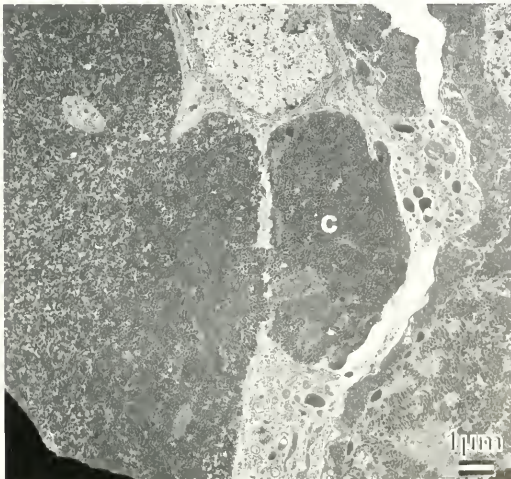

Fig. 12. Detail of a cell (C) beginning to discharge virions into lumen.

## ACKNOWLEDGMENTS

All electron microscopy was performed at the Texas A&M University Microscopy and Imaging Center. The senior author is grateful to Jim Whitfield, Don Stoltz, Mike Strand, Jo-Ann Fleming, and Brad Vinson for helpful comments relative to their own work on polydnnaviruses. The helpful suggestions of two anonymous reviewers are also gratefully acknowledged.

## LITERATURE CITED

- Barratt, B. I. P., A. A. Evans, D. B. Stoltz, S. B. Vinson and R. Easingwood. 1999. Virus-like particles in the ovaries of *Microctonus aethiopoidea* Loeb (Hymenoptera: Braconidae), a parasitoid of adult weevils (Coleoptera: Curculionidae). *Journal of Invertebrate Pathology* 73: 182–188.
- Beckage, N. E. 1997. The parasitic wasp's secret weapon. *Scientific American* Nov. 1997: 82–87.
- De Buron, I. and N. E. Beckage. 1992. Characterization of a polydnnavirus (PDV) and virus-like filamentous particle (VLFP) in the braconid wasp *Cotesia congregata* (Hymenoptera: Braconidae). *Journal of Invertebrate Pathology* 59: 315–327.
- Dib-Hajj, S. D., B. A. Webb and M. D. Summers. 1993. Structure and evolutionary implications of a "cysteine-rich" *Campoletis sonorensis* polydnnavirus gene family. *Proceedings of the National Academy of Sciences* 90: 3765–3769.
- Edson, K. M., S. B. Vinson, D. B. Stoltz and M. D. Summers. 1981. Virus in a parasitoid wasp: Suppression of the cellular immune response in the parasitoid's host. *Science* 211: 582–583.
- Fleming, J. G. W. 1992. Polydnnaviruses: Mutualists and pathogens. *Annual Review of Entomology* 37: 401–425.
- Kalt, M. R. and B. Tandler. 1971. A study of fixation of early amphibian embryos for electron microscopy. *Journal of Ultrastructure Research* 36: 633–645.
- Krell, P. J. 1991. Polydnnaviridae, pp. 321–338. In: Adams, J. R. and J. R. Bonami (eds.), *Atlas of Invertebrate Viruses*. CRC Press, Boca Raton.
- Lawrence, P. O. and D. Akin. 1990. Virus-like particles from the poison glands of the parasitic wasp *Biosteres longicaudatus* (Hymenoptera: Braconidae). *Canadian Journal of Zoology* 68: 539–546.
- Mason, W. R. M. 1981. The polyphyletic nature of *Apanteles* Foerster (Hymenoptera: Braconidae): A phylogeny and reclassification of Microgasterinae. *Memoirs of the Entomological Society of Canada* 115: 1–147.
- Mollenhauer, H. H. 1964. Plastic embedding mixtures for use in electron microscopy. *Stain Technology* 39: 111–114.
- Muesebeck, C. F. W. 1922. A revision of the North American ichneumon-flies belonging to the subfamilies Neoneurinae and Microgasterinae. *Proceedings of the United States National Museum* 61: 1–76.
- Nixon, G. E. J. 1965. A reclassification of the Tribe Microgasterini (Hymenoptera: Braconidae). *Bulletin of the British Museum (Natural History) Entomology Supplement* 2: 1–284.
- Reynolds, E. S. 1963. The use of lead citrate at high pH as an electron-opaque stain in electron microscopy. *Journal of Cell Biology* 17: 208–212.
- Salt, G. 1968. The resistance of insect parasitoids to the defence of their hosts. *Biological Reviews* 43: 200–232.
- Stoltz, D. B. 1993. The polydnnavirus life cycle, pp. 167–187. In: Beckage, N. E., S. N. Thompson and B. A. Federici (eds.), *Parasites and Pathogens of Insects, Vol. 1: Parasites*. Academic Press, San Diego.
- Stoltz, D. B., P. Krell, M. D. Summers and S. B. Vinson. 1984. Polydnnaviridae—a proposed family of insect viruses with segmented, double-stranded, circular DNA genomes. *Intervirology* 21: 1–4.
- Stoltz, D. B. and S. B. Vinson. 1977. Baculovirus-like particles in the reproductive tracts of female parasitoid wasps II: The genus *Apanteles*. *Canadian Journal of Microbiology* 23: 28–37.
- Stoltz, D. B. and S. B. Vinson 1979. Viruses and parasitism in insects. *Advances in Virus Research* 24: 125–171.
- Stoltz, D. B., S. B. Vinson and E. A. MacKinnon. 1976. Baculovirus-like particles in the reproductive tracts of female parasitoid wasps. *Canadian Journal of Microbiology* 22: 1013–1023.
- Stoltz, D. B. and J. B. Whitfield. 1992. Viruses and virus-like entities in the parasitic Hymenoptera. *Journal of Hymenoptera Research* 1: 125–139.
- Strand, M. R. and L. L. Pech. 1995. Immunological basis for compatibility in host-parasitoid relationships. *Annual Review of Entomology* 40: 31–56.
- Van Achterberg, C. 1993. Illustrated key to the subfamilies of the Braconidae (Hymenoptera: Ichneumonoidea). *Zoologische Verhandlungen* 283: 1–189.
- Webb, B. A. 1998. Polydnnavirus biology, genome structure, and evolution. In: Miller, L. K. and L. A. Ball (eds.), *The Insect Viruses*. Plenum Press, New York.
- Wharton, R. A. 1993. Bionomics of the Braconidae. *Annual Review of Entomology* 38: 121–143.
- Whitfield, J. B. 1990. Parasitoids, polydnnaviruses and endosymbiosis. *Parasitology Today* 6: 381–384.
- Whitfield, J. B. 1997. Molecular and morphological data suggest a single origin of the polydnnaviruses among braconid wasps. *Naturwissenschaften* 84: 502–507.
- Whitfield, J. B. 2000. Phylogeny of microgastroid

braconid wasps, and what it tells us about polydnavirus evolution, pp. 97–105. In: Austin, A. D. and M. Dowton (eds.), *Hymenoptera Evolution, Biodiversity and Biological Control*. CSIRO Publishing, Collingwood.

Whitfield, J. B. and W. R. M. Mason. 1994. Mendellinae, a new subfamily of braconid wasps (Hymenoptera, Braconidae) with a review of relationships within the microgastroid assemblage. *Systematic Entomology* 19: 61–76.

## NOTE

### Authorship of the Family-Group Names Palarini and Xenosphecini (Hymenoptera: Apoidea: Crabronidae)

A. S. MENKE AND W. J. PULAWSKI

(ASM) Systematic Entomology Laboratory, PSI, USDA, National Museum of Natural History, Washington D.C. 20560-0168, USA (current mailing address: Ammophila Research Institute, 1429 Franklin St., Bisbee, AZ 85603-6211, USA, asm@theriver.com); (WJP) Dept. of Entomology, California Academy of Sciences, San Francisco, California 94118-4599, USA, wpulawski@calacademy.org

Palarini Schrottky, 1909

In a review of family-group names in apoid wasps, Menke (1997) attributed the name Palarini to Börner (1919). However, the South American entomologist Curt Schrottky used the name Palaridae earlier. The oldest was Schrottky (1909:249) where he simply used "Fam. Palaridae" as a header for a species of *Pisonopsis* and two species of *Tachytes*. Schrottky (1913:230) again used the name Palaridae as a header for the aforementioned genera as well as *Tachysphex*, *Larrada* and *Heliocausus*.

Schrottky did not mention the Old World genus *Palarus* or indicate why he was using the name Palaridae. We have searched the literature of contemporary authors in South America and can find no mention of Palaridae. A perusal of the literature of contemporary European authors that Schrottky may have known such as Handlirsch and André, revealed no use of the name.

The fourth edition of the Code of Zoological Nomenclature makes it clear that Schrottky (1909) gets credit for authorship of the name Palaridae even though he did not mention *Palarus*. Article 11.7.1.1 states "... use of the stem alone in forming the [new family-group] name is accepted as evidence that the author used the generic name as valid in the new family-group taxon unless there is evidence to the contrary".

Palaridae is currently recognized as a tribe in the subfamily Crabroninae (= Larriinae of authors).

We thank Izyaslav M. Kerzhner and F. Christian Thompson for clarifying the nomenclatorial status of Palaridae Schrottky.

Xenosphecini Parker, 1966

Bohart and Menke (1976:51, 437) established the subfamily Xenosphecinae unaware that Frank Parker (1966:195) had proposed the tribal name Xenosphecini for the genus *Xenosphex*. Menke (1997) also overlooked Parker's name. Authorship of Xenosphecini is Parker, 1966. Currently this tribe is placed in the subfamily Melininae (Prentice 1998).

#### LITERATURE CITED

- Bohart, R. M. and A. S. Menke. 1976. *Sphexid Wasps of the World*. Univ. of California Press, Berkeley. ix+695 p.
- Börner, C. 1919. Stammesgeschichte der Hautflügler. *Biologisches Zentralblatt* 39: 145–186.
- Menke, A. S. 1997. Family-Group names in Sphecidae (Hymenoptera: Apoidea). *Journal of Hymenoptera Research* 6: 243–255.
- Parker, F. D. 1966. A review of the genus *Xenosphex* Williams with biological notes. *Pan-Pacific Entomologist* 42: 190–195.
- Prentice, M. A. 1998. *The comparative morphology and phylogeny of apoid wasps (Hymenoptera, Apoidea)*.

- Ph.D. Dissertation, University of California, Berkeley. 1439 p.
- Schrottky, C. 1909. Himenópteros de Catamarca. *Anales de la Sociedad Científica Argentina* 68: 233–272.
- Schrottky, C. 1913. La distribución geográfica de los Himenópteros Argentinos. *Anales de la Sociedad Científica Argentina*. 75: 115–144, 180–224, 225–286.

## NOTE

### *Ascogaster bugabensis* Cameron Belongs in the Helconinae *sensu lato* (Hymenoptera: Braconidae)

SCOTT R. SHAW AND SAMIN DADELAHI

U.W. Insect Museum, Department of Renewable Resources, University of Wyoming,  
Laramie, Wyoming 82071-3354, USA, SRS email: braconid@uwyo.edu

*Ascogaster bugabensis* was described by Cameron (1887) based on a single female specimen from Bugaba, Panama. For more than 100 years this species has remained virtually unstudied. Other than being cited in catalogs (Shenefelt 1973) the species has not been mentioned in literature, and to the best of our knowledge it remains known only by the holotype. Until now it has been classified, according to its original combination, as a member of the braconid subfamily Cheloninae (Shenefelt 1973). During a recent study of Costa Rican Cheloninae (Dadelahi 2001) we examined the holotype of *Ascogaster bugabensis* Cameron and discovered that it does not belong in the genus *Ascogaster* or even within the subfamily Cheloninae. Instead, it clearly belongs in the genus *Urosigalphus* Ashmead, which is currently classified in the tribe Brachistini of the subfamily Helconinae *sensu lato* (Sharkey 1997). Because it was classified in the wrong genus and subfamily, this species was entirely overlooked in the most recent revisions of *Urosigalphus* (Gibson 1972a, 1972b, 1974). Since this discovery is outside the scope of our revisionary studies of Cheloninae, we are presenting this information here as a scientific note.

The holotype of *Ascogaster bugabensis* Cameron is in very poor condition. The specimen is double-mounted with a very large minuten pin directly through the mesosoma. The diameter of this mounting pin is nearly as wide as the mesosoma it-

self, which is severed. The posterior half of the mesosoma, and the metasoma, are glued directly to the polyporous mounting strip with a golden brown substance (possibly Canadian balsam). Except for some basal portions, most of the antennae and legs are broken and missing. Despite this damage, several important characters can be clearly observed. The metasomal terga are fused to form a solid carapace lacking transverse sutures. Although superficially similar to the fused carapace of the Cheloninae, this condition is now known to be a convergent evolutionary trend, which manifests itself in several unrelated braconid groups (Dudarenko 1974). This specimen exhibits a robust carapace form, with coarse punctate sculpture, and long ovipositor, which is not known to occur in any New World *Ascogaster* (Shaw 1983) but is typical of carapaces as seen in the genus *Urosigalphus* (Gibson 1972a, 1972b, Sharkey 1997). Even more definitive is the forewing, which lacks the r-m crossvein (and consequently, lacks a closed second submarginal cell). The r-m crossvein and a closed second submarginal cell are present in all genera of Cheloninae, including *Ascogaster* (Shaw 1997). The forewing venation pattern matches exactly that known for species of *Urosigalphus* (Sharkey 1997, fig. 9). Consequently, on the basis of this evidence, the species is hereby reclassified as follows: *Urosigalphus bugabensis* (Cameron) **NEW COMBINATION.**

Using the key to subgenera provided by Gibson (1972b), *Urosigalphus bugabensis* can be placed in the subgenus *Neurosigalphus* Gibson. This determination is based on the following combination of characters, which can be observed in the holotype: marginal cell closed (= radial cell *sensu* Gibson), ocellar triangle not raised into a pyramidal projection, scutellum not elevated into a point, lower face rounded, and palpi elongate. Placement of the species in Gibson's (1972b) key to Central American species of the subgenus *Neurosigalphus* is difficult because of the broken antennae and legs of the holotype. If we assume that Cameron's description is correct in stating that the antennae are "16-jointed" and the legs are "red," then *U. bugabensis* keys to *U. avocadoae* Gibson (a parasitoid of "Avocado tree borer"). We examined and identified 68 specimens of Costa Rican *Urosigalphus* in the collection of the University of Wyoming Insect Museum. Of these, we found ten specimens that key to *U. avocadoae* but appear morphologically identical to the holotype of *U. bugabensis*. These were from several localities ranging in elevation from 50–1100 m. These specimens exhibit a wide range of leg color variations, from dark reddish brown to bright yellow. Since the holotype of *U. bugabensis* is a female and *U. avocadoae* was described based only on males, it is not possible at present to determine if the species are distinct or merely synonyms. Hopefully, future studies may resolve this issue by rearing both sexes from infested Avocado trees.

#### ACKNOWLEDGMENT

We wish to thank Ms. Suzanne Lewis, Department of Entomology, the Natural History Museum, Lon-

don, for kindly making available for study the holotype of *Ascogaster bugabensis* Cameron.

#### LITERATURE CITED

- Cameron, P. 1887. Family Braconidae. In, *Biologia Centrali-Americana. Insecta*. 1: 312–419.
- Dadelahi, S. D. 2001. A taxonomic study of Costa Rican *Leptodrepana* (Hymenoptera: Braconidae: Cheloniinae). Master's Thesis, Department of Renewable Resources, University of Wyoming, Laramie. 101 pp.
- Dudarenko, G. P. 1974. Formation of the abdominal carapace in braconids (Hymenoptera: Braconidae) and some aspects of the classification of the family. *Entomological Review* 53: 80–90.
- Gibson, L. P. 1972a. Revision of the genus *Urosigalphus* of the United States and Canada (Hymenoptera: Braconidae). *Miscellaneous Publications of the Entomological Society of America* 8: 83–134.
- Gibson, L. P. 1972b. *Urosigalphus* of Mexico and Central America (Hymenoptera: Braconidae). *Miscellaneous Publications of the Entomological Society of America* 8: 135–157.
- Gibson, L. P. 1974. South American *Urosigalphus* (Hymenoptera: Braconidae). *Miscellaneous Publications of the Entomological Society of America* 9: 201–226.
- Sharkey, M. J. 1997. Subfamily Helconinae. Pp. 260–272. In, Wharton, R. A., Marsh, P. M. and M. J. Sharkey (Eds.), *Manual of the New World Genera of the Family Braconidae (Hymenoptera)*. Special Publication of the International Society of Hymenopterists, Number 1.
- Shaw, S. R. 1983. A taxonomic study of Nearctic *Ascogaster* and a description of a new genus *Leptodrepana* (Hymenoptera: Braconidae). *Entomography* 2: 1–54.
- Shaw, S. R. 1997. Subfamily Cheloniinae. Pp. 192–201. In, Wharton, R. A., Marsh, P. M. and M. J. Sharkey (Eds.), *Manual of the New World Genera of the Family Braconidae (Hymenoptera)*. Special Publication of the International Society of Hymenopterists, Number 1.
- Shenefelt, R. D. 1973. Pars 10. Braconidae 6, Cheloniinae. Pp. 813–936. In, Vecht, J. van der and Shenefelt, R. D. (Eds.). *Hymenopterorum Catalogus (novo editio)*, Dr. W. Junk, The Hague.

NOTE

**First Host Record for the Parasitic Wasp Genus *Notiopambolus*  
Achterberg and Quicke (Hymenoptera: Braconidae: Pambolinae)**

ALEJANDRO ZALDIVAR-RIVERÓN AND DONALD L. J. QUICKE

(AZR, DLJQ) Department of Biological Sciences, Imperial College of Science, Technology and Medicine at Silwood Park, Ascot, Berkshire SL5 7PY, UK, AZR email: alejandro.zaldivar-riveron@ic.ac.uk; DLJQ email: d.quicke@ic.ac.uk; (DLJQ) Department of Entomology, The Natural History Museum, London SW7 5BD, UK

During study of the Braconidae accessions collection at The Natural History Museum (London, UK), the junior author discovered an Australian pamboline specimen reared from the larval/pupal case of

a beetle. Determination of this wasp using the key for the Australian Pambolinae species given by Belokobylskij (1992) and comparison with paratype material indicates that it belongs to *Notiopambolus de-*

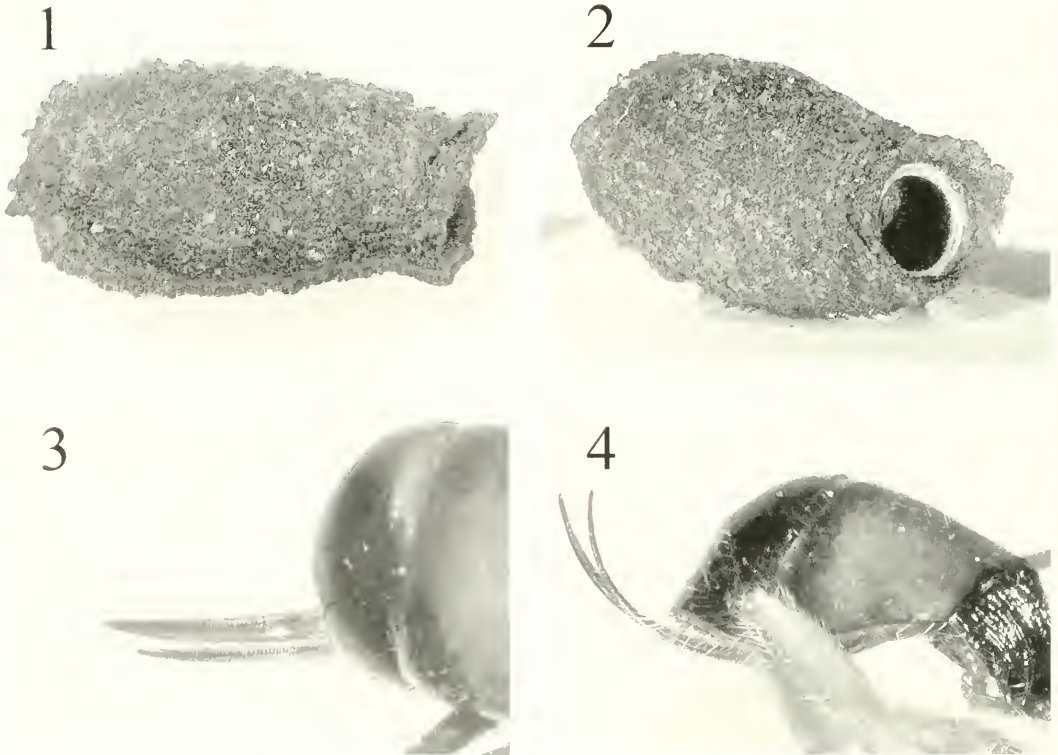

Figs. 1-4. Automontage® photographs of reared specimen of *Notiopambolus depressicaudus* and its associated host remains (Coleoptera: Chrysomelidae: Cryptocephalinae). Dorsal (Fig. 1) and lateral (Fig. 2) view of host remains; length and width of the pupal/larval case = 7 and 3 mm, respectively. Dorsal (Fig. 3) and lateral (Fig. 4) view of the wasp ovipositor showing dorso-ventral compression and curvature.

*pressicauda* Achterberg and Quicke (1990). The data label states that the host was collected in 1958 in Victoria, Australia, by M. F. Leask, and the wasp emerged on January 15, 1958. Since the host remains were kept with the wasp, it was possible to confirm that it belongs to a chrysomelid beetle larva or pupa of the subtribe Cryptocephalina (Cryptocephalinae) (Figs 1, 2). This represents the first host record for the genus *Notiopambolus* Achterberg and Quicke, and also the first confirmed record for any species belonging to the subfamily Pambolinae. The only previous associations for Pambolinae concern some Palaearctic *Pambolus* Haliday species, which have been mentioned in the literature as parasitoids of Buprestidae and Chrysomelidae beetle larvae but without any detailed observations or comments (Leonardi 1926, Belokobylskij 1986, 1987, 1993, Shaw and Huddleston 1991, Whitfield and Wharton 1997). Interestingly, as its name suggests, the ovipositor of *N. depressicauda* (and indeed of all *Notiopambolus* species) is strongly dorsoventrally compressed and up-curved (Figs 3, 4). Given that the host lives in a hard larval/pupal case that would in life be located on its substrate (i.e., dead leaves accumulated on the ground, Lawrence and Britton 1991) with the opening held closely to the surface, it is probable that this wasp attacks its host by inserting its ovipositor between the substrate and the case; but direct observational confirmation is required.

#### ACKNOWLEDGMENT

We want to thank Dr. Chris Reid from the Australian Museum, Sydney, New South Wales, for identifying the host remains via the internet.

#### LITERATURE CITED

- Achterberg, C. van. and D. L. J. Quicke. 1990. A new genus of the tribe Pambolini from Australia (Hymenoptera: Braconidae). *Zoologische Mededelingen* 64: 177-181.
- Belokobylskij, S. A. 1986. A review of the Palaearctic species of the genera *Pambolus* Haliday and *Dimeris* Ruthe (Hymenoptera: Braconidae). *Proceedings of the Zoological Institute, Leningrad* 159: 18-37. (In Russian.)
- Belokobylskij, S. A. 1987. Structure of the male genitalia in braconid subfamily Doryctinae (Hymenoptera Braconidae)—its evolution and significance in classification of the group. *Morphological Foundations for Insect Phylogeny* 69: 209-219. (In Russian.)
- Belokobylskij, S. A. 1992. Braconid wasps of the tribe Pambolini (Hymenoptera, Braconidae) of Australia. *Entomologicheskoe Obozrenie* 71 (1): 179-198. (English translation 1993 *Entomological Review* 72 (2): 46-65.)
- Belokobylskij, S. A. 1993. On the classification and phylogeny of the braconid wasp subfamilies Doryctinae and Exothecinae (Hymenoptera: Braconidae). Part II. On the phylogeny. *Entomologicheskoe Obozrenie* 72 (4): 891-914. (English translation 1994 *Entomological Review* 73 (8): 1-27.)
- Lawrence, J. F. and E. B. Britton. 1991. Chapter 35: Coleoptera. Pp. 687-688. In: Division of Entomology Commonwealth scientific and Industrial Research Organisation (CSIRO) Australia (Eds.). *The Insects of Australia. Volume 2*. Melbourne University Press, Victoria.
- Leonardi, G. 1926. Elenco delle specie di insetti dannosi e loro parassiti ricordati in Italia fino all'anno 1911. Parte II, fasciolo III. Ord. Coleoptera. *Annali del Regio Istituto Superiore Agrario di Portici (Serie Terza)* 1: 148-295.
- Shaw, M. R. and T. Huddleston. 1991. Classification and biology of braconid wasps (Hymenoptera: Braconidae). *Handbooks for the Identification of British Insects* 7 (11): 1-126.
- Whitfield, J. B. and R. A. Wharton. 1997. Subfamily Hormiinae. Pp. 285-301. In: Wharton, R. A., P. M. Marsh and M. J. Sharkey (Eds.). *Manual of the new world genera of the family Braconidae (Hymenoptera)*. *Special Publication of the International Society of Hymenopterists* 1: 1-439.







## INSTRUCTIONS FOR AUTHORS

**General Policy.** The *Journal of Hymenoptera Research* invites papers of high scientific quality reporting comprehensive research on all aspects of Hymenoptera, including biology, behavior, ecology, systematics, taxonomy, genetics, and morphology. Taxonomic papers describing single species are unlikely to be accepted unless a strong case is evident, such as importance in economic entomology or with concurrent biology or ecology. Manuscript length generally should not exceed 50 typed pages; however, no upper limit on length has been set for papers of exceptional quality and importance, including taxonomic monographs at generic or higher level. All papers will be reviewed by at least two referees. The referees will be chosen by the appropriate subject editor. However, it would be helpful if authors would submit the names of two persons who are competent to review the manuscript. The language of publication is English. Summaries in other languages are acceptable.

**The deadline for receipt of manuscripts is 1 September (for the April issue) and 1 March (for the October issue).**

**Format and Preparation.** Three copies of each manuscript, including copies of illustrations, should be submitted on letter size or A4 paper, double spaced, with at least 25 mm margins on all sides. On the upper left of the title page give name, address, telephone and fax numbers, and e-mail address of the author to whom all correspondence is to be sent. The paper should have a concise and informative title, followed by the names and addresses of all authors. The sequence of material should be: title, author(s), abstract, text, acknowledgments, literature cited, appendix, figure legends, figure copies (each numbered and identified), tables (each numbered and with heading). Each of the following should start a new page: (1) title page, (2) abstract, (3) text, (4) literature cited, (5) figure legends, (6) footnotes.

Upon final acceptance of a manuscript, the author should provide the editor with one copy accompanied by either an IBM or Macintosh formatted electronic version. ZIP discs, CD-ROMS, or 3.5 inch floppy discs are acceptable. Final manuscripts and figures may also be sent via email, but because symbols and tables are not always correctly translated it is still best to send a printed copy of the manuscript. Preferred word processing programs are Microsoft Word, WordPerfect, and MacWrite Pro. If possible, all words that must be italicized should be done so, not underscored. Tables may be formatted in a spread sheet program such as MS Works or MS Excel. Text should be double-spaced typing, with 25 mm left and right margins. Tables should be put in a separate file. Diskettes should be accompanied by the name of the software program used (e.g., WordPerfect, Microsoft Word). Authors should keep backup copies of all material sent to the Editor. The Society cannot be responsible for diskettes or text mislaid or destroyed in transit or during editing.

Illustrations should be planned for reduction to the dimension of the printed page (14 × 20.5 cm, column width 6.7 cm) and allow room for legends at the top and bottom. Do not make plates larger than 14 × 18 in. (35.5 × 46 cm). Individual figures should be mounted on a suitable drawing board or similar heavy stock. Photographs should be trimmed, grouped together and abutted when mounted. Figure numbers should be on the plate. Include title, author(s) and address(es), and illustration numbers on back of each plate. Original figures need not be sent until requested by the editor, usually after the manuscript has been accepted. Reference to figures/tables in the text should be in the style "(Fig. 1)" "(Table 1)". Measurements should be in the metric system.

Electronic plates may be submitted on disc or via email. They must be fully composited, labeled, and sized to fit the proportions of the journal page. Line art should be scanned at 1200 dpi (minimum input resolution is 600 dpi). Color or grayscale (halftone) images should have a dpi of 300–350. Color files should be in CMYK and not RGB. Graphics should be submitted as TIFF or EPS files. No PowerPoint or Word/WordPerfect files with images embedded in them are acceptable.

All papers must conform to the *International Code of Zoological Nomenclature*. The first mention of a plant or animal should include the full scientific name including the authority. Genus names should not be abbreviated at the beginning of a sentence. In taxonomic papers type specimens must be clearly designated, type depositories must be clearly indicated, and new taxa must be clearly differentiated from existing taxa by means of keys or differential diagnoses. Authors are required to deposit all type material in internationally recognized institutions (not private collections). Voucher specimens should be designated for specimens used in behavioral or autecological studies, and they should be deposited similarly.

Acceptance of taxonomic papers will not require use of cladistic methods; however, authors using them will be expected to specify the phylogenetic program used (if any), including discussion of program options used. A data matrix should be provided if the subject is complex. Cladograms must be hung with characters and these should include descriptors (not numbers alone) when feasible. The number of parsimonious cladograms generated should be stated and reasons given for the one adopted. Lengths and consistency indices should be provided. Adequate discussions should be given for characters, plesiomorphic conditions, and distributions of characters among outgroups when problematical.

References in the text should be (Smith 1999), without a comma, or Smith (1999). Two articles by a single author should be (Smith 1999a, 1999b) or Smith (1999a, 1999b). For multiple authors, use the word "and," not the symbol "&" (Smith and Jones 1999). For papers in press, use "in press," not the expected publication date. The Literature Cited section should include all papers referred to in the paper. Journal names should be spelled out completely and in italics.

**Charges.** Publication charges are \$10.00 per printed page. At least one author of the paper must be a member of the International Society of Hymenopterists. Reprints are charged to the author and must be ordered when returning the proofs; there are no free reprints. Author's corrections and changes in proof are also charged to the author. Color plates will be billed at full cost to the author.

All manuscripts and correspondence should be sent to:

Dr. E. Eric Grissell  
Systematic Entomology Laboratory, USDA  
Smithsonian Institution  
P.O. Box 37012  
National Museum of Natural History CE 520, MRC168  
Washington, DC 20013-7012

Phone: (202) 382-1781 Fax: (202) 786-9472 E-mail: egrissell@sel.barc.usda.gov

WHARTON, R. A. and H. SITTERTZ-BHATKAR. Polydnaviruses in the genus <i>Mirax</i> Haliday (Hymenoptera: Braconidae) .....	358
--	-----

NOTES:

MENKE, A. S. and W. J. PULAWSKI. Authorship of the family-group names Palarini and Xenospecini (Hymenoptera: Apoidea: Crabronidae) .....	366
SHAW, S. R. and S. DADELAHI. <i>Ascogaster bugabensis</i> Cameron belongs in the Helconinae <i>sensu lato</i> (Hymenoptera: Braconidae) .....	368
ZALDIVAR-RIVERÓN, A. and D. L. J. QUICKE. First host record for the parasitic wasp genus <i>Notiopambolus</i> Achterberg and Quicke (Hymenoptera: Braconidae: Pambolinae) .....	370





**HECKMAN**  
B I N D E R Y . I N C.  
Bound-To-Please®  
**JUNE 03**  
N. MANCHESTER, INDIANA 46962

SMITHSONIAN INSTITUTION LIBRARIES



3 9088 01058 9588

**BHL**