

24

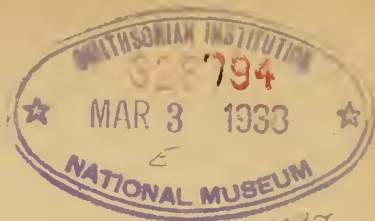

THE

UNIVERSITY STUDIES

OF THE

UNIVERSITY OF NEBRASKA

VOLUME VII

LINCOLN
PUBLISHED BY THE UNIVERSITY
1907

CONTENTS

FRYE—Dryden and the Critical Canons of the Eighteenth Century.....	1
ENGLAND—Statistical Inquiry into the Influence of Credit on the Level of Prices	41
HOLMAN—Fatigue and the Recovery of the Photo-Electric Current....	125
STURDEVANT—Some Variations in <i>Hymenolepis diminuta</i>	135
HALL—A Study of some Gregarines with Especial Reference to <i>Hirmo-</i> <i>cystis rigida</i> f. sp.....	149
BOLTON AND WITHEY—On the Relation of Muscle Sense to Pressure Sense	175
POWERS—Morphological Variation and its Causes in <i>Amblystoma</i> <i>tigrinum</i>	197
BESSEY—A Synopsis of Plant Phyla.....	275

270

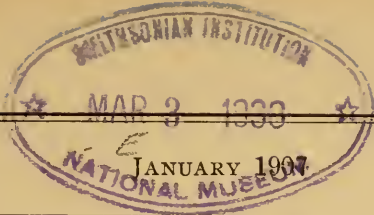

Vol. VII

No. 1

UNIVERSITY STUDIES

Published by the University of Nebraska

COMMITTEE OF PUBLICATION

C. E. BESSEY

H. ALICE HOWELL

T. L. BOLTON

W. K. JEWETT

F. M. FLING

L. A. SHERMAN

W. G. L. TAYLOR

CONTENTS

I	DRYDEN AND THE CRITICAL CANONS OF THE EIGHTEENTH CENTURY	
	<i>Prosser Hall Frye</i>	1
II	STATISTICAL INQUIRY INTO THE INFLUENCE OF CREDIT UPON THE LEVEL OF PRICES	
	<i>Minnie Throop England</i>	41

LINCOLN NEBRASKA

UNIVERSITY STUDIES

VOL. VII

JANUARY 1907

No. 1

I.—*Dryden and the Critical Canons of the Eighteenth Century*

BY PROSSER HALL FRYE

I

Dryden's spirit, like that of the whole age which he determined, was largely, as we look at these matters nowadays, a prose spirit. That is, it was marked by common sense or intelligence more strongly than by fancy or imagination. In general terms he may be defined as a man of parts who applied himself to the business of letters. His lack of creative power is very conspicuous. He never in all his plays made a character. His dramas have no illusion. Even their mechanical construction is rather rickety. His themes are usually suggested, and his materials are frequently furnished in part, either by some other writer, as in *Amphitryon*, which is a clever compilation of Molière and Plautus and in some respects better than either, or else by some current truism or commonplace of the day. For this reason he is at his best poetically in translation or in satire. For even in poetry his chief merit is to say things in a downright manner, to hit the nail on the head and hit it hard. This is no despicable quality, to be sure, but it is on the whole a quality more proper to prose than to poetry.

Indeed, in Dryden's conception and practice poetry is very nearly identical with propriety of thought and expression; that

is, the thought or the sentiment must be just and the language suitable—clear, discursive, without grammatical violence, ellipses, inversions, and the like. He was not the first, as a matter of fact, to make wit and poetry synonymous; but he was the first to give that definition the support of a systematic criticism and the authority of a powerful example. "Wit," he says, is "a propriety of thoughts and words."¹ And again, "a thing well said is wit in any language." If poetry, therefore, is nothing else than wit, poetry must obviously consist in a propriety of thoughts and words or in saying a thing well. And as this was virtually the idea of poetry that was to obtain for nearly a century and a half in English literature under the general canon of correctness, it would be as well to scrutinize it rather closely.

After all, it can not be denied that there is poetic quality in mere neatness of expression. The saying of a thing simply, clearly, and pointedly is poetic in itself. The French have always recognized such a character in aptness of expression; indeed, rhyme aside, much of their poetry differs from prose only in being more nicely expressed. And the French are right as usual in these matters; for such a style is essentially organic. It fills the mind with perfectly clear ideas and images, and dispels the vague, the obscure, and the nebulous. It is this property of exquisite aptitude, of saying a thing plainly and yet fitly, which contributes to make Keats' *Grecian Urn* what it is—classic poetry in the noblest sense.

"What little town by river or sea shore
Or mountain-built with peaceful citadel,
Is emptied of this folk, this pious morn?"

Or to take an example from Dryden himself:

"But Shakespeare's magic could not copied be,
Within that circle none durst walk but he."

Though there is, to be sure, imagination; or at least fancy, in the figure; it is the propriety of the expression as a whole which is mainly responsible for the charm—a propriety which would not be amiss in prose but would be in its degree poetic anywhere.

¹Dryden. *The Author's Apology for Heroic Poetry and Poetic License.*

Of such bare correctness of expression without imaginative gilding or alloy it is Pope, however, who is the great master, as the currency of his phrases testifies. And remarkably enough, such is the capability of the process in its perfection, he has succeeded in imparting to these bald *sententiae* a kind of vague emotional thrill, a sort of sentimental tremulo, as though they were even more than they are.

“E’en copious Dryden wanted, or forgot,
The last and greatest art, the art to blot.”

This is very little, if at all, better than prose; and yet how well it apes the sensibility of poetry!

“The last and greatest art, the art to blot”!

It has quite the romantic quaver.

In order to define this idea of propriety a little more exactly it might be well to compare, with such verses as these of Pope’s and Dryden’s, a poetry like the Elizabethan which neither recognized nor followed any such principle. In *Troilus and Cressida* Shakespeare has an admired passage, which begins as follows:

“But value dwells not in particular will;
It holds his estimate and dignity
As well wherein ’t is precious of itself
As in the prizer: ’t is mad idolatry
To make the service greater than the God.”¹

Here the purpose is the same as Pope’s and Dryden’s—the expression of a general moral truth. The four first lines lack clearness, but the figure is admirable and quite in Pope’s and Dryden’s way. They might either of them have been glad to write it, if they could have done so. But what they never would have done—they would never have concluded the passage as Shakespeare does.

“And the will dotes that is attributive
To what infectiously itself affects
Without some image of the affected merit.”

It was this kind of thing in Shakespeare and his contemporaries which offended so much the taste of the succeeding age.

¹ Shakespeare. *Troilus and Cressida*, II, ü.

And indeed it is not difficult to conceive that to such an age, as to Jonson, Shakespeare should seem to have "wanted art." In his *Defense of the Epilogue* Dryden remarks:

"Malice and partiality set aside, let any man, who understands English, read diligently the works of Shakespeare and Fletcher, and I dare undertake, that he will find in every page either some solecism of speech, or some notorious flaw in sense. . . Poetry was then, if not in its infancy among us, at least not arrived to its vigor and maturity: witness the lameness of their plots; many of which . . . were made up of some ridiculous incoherent story, which in one play many times took up the business of an age. I suppose I need not name *Pericles, Prince of Tyre*, nor the historical plays of Shakespeare: besides many of the rest, as the *Winter's Tale*, *Love's Labour Lost*, *Measure for Measure*, which were either grounded on impossibilities, or at least so meanly written, that the comedy neither caused your mirth, nor the serious part your concernment."

While a little later he speaks of "bombast speeches of Macbeth,"¹ and eventually disposes of Shakespeare pithily in this fashion:

"Shakespeare, who many times has written better than any poet, in any language, is yet so far from writing wit always, or expressing that wit according to the dignity of the subject, that he writes, in many places, below the dullest writer of ours, or any precedent age. Never did any writer precipitate himself from such height of thought to so low expressions, as he often does. He is the very Janus of poets; he wears almost everywhere two faces; and you have scarce begun to admire the one, ere you despise the other."²

Now it must be confessed that these extracts do not represent Dryden's best critical tone. They were written in support of certain arrogances to which he had committed himself, when flown with the insolence of success, in an epilogue to the second part of the *Conquest of Granada*. But at the same time they do represent the tendency of his criticism, and what is more important in this connection, the temper of the time in which they were written. And after all, indiscriminate as the criticism is, it has a kind of general justice. If there is one test by which the work of an artist—for such is the modern equivalent of "wit"—may be known, it is by its evenness, its being all of a piece,—in short,

¹Dryden. *Defense of the Epilogue*.

²*Ibid.*

by its propriety. An artist is particularly distinguished by the adaptation of his means to his end. But for the impartial critic to overlook the inequalities—above all, the extravagance and waste of the Elizabethans, even of Shakespeare himself, is impossible. The amount of genius that Shakespeare frequently squandered on a play is something appalling and is quite enough in itself to justify the distinction that Dryden was attempting.¹ For as a matter of fact this distinction between artist and genius, of which so much has been made within our own memory, is quite in the vein of the eighteenth century and was drawn by them before us. Substantially to the same effect as Dryden, though more temperately, Addison gives to this criticism, in *Spectator* No. 160, what may be called its classical expression:

“Among great genius’s, those few draw the admiration of the world upon them, and stand up as the prodigies of mankind, who by the mere strength of natural parts, and without any assistance of art or learning, have produced works that were the delight of their own times and the wonder of posterity. There appears something nobly wild and extravagant in these great genius’s that is infinitely more beautiful than all the turn and polishing of what the *French* call a *bel esprit*, by which they would express a genius refined by conversation, reflection, and the reading of the most polite authors. . . .

“Many of these great natural genius’s that were never disciplined and broken by the rules of art, are to be found among the ancients, and in particular among those of the more eastern parts of the world. . . . At the same time that we allow a greater and more daring genius to the ancients, we must own that the greatest of them very much failed in, or, if you will, that they were much above the nicety and correctness of the moderns. . . .

“There is another kind of great genius’s which I shall place in a second class, not as I think them inferior to the first, but only for distinction’s sake as they are of a different kind. This second class of great genius’s are those that have formed themselves by rules, and submitted the greatness of their natural talents to the corrections and restraints of art. . . .

“The genius in both these classes of authors may be equally great, but it shews itself after a different manner. In the first it is like a rich soil in a happy climate, that produces a whole wilderness of noble plants rising in a thousand beautiful landskips without any certain order or regularity.

¹“I think there is no folly so great in any part of our age, as the superfluity and waste of wit was in some of our predecessors.” Dryden, *Preface to an Evening’s Love*.

In the other it is the same rich soil under the same happy climate, that has been laid out in walks and parterres, and cut into shape and beauty by the skill of the gardener."

What alone is singular in these statements is Addison's indulgence for the untutored genius, whom he affected rather more than his time, which would hardly have agreed with him in conceding that "both these classes of authors may be equally great." Otherwise the paper is a sufficiently orthodox expression of eighteenth century opinion.

II

But while it is all very well to propose correctness as an attribute of poetry, there is one obvious difficulty. Without some satisfactory definition and standard of correctness the prescription is useless. In a certain limited sense such a standard is supplied by the ordinances of grammar as well as those of rhyme and meter. But such a standard is not very far-reaching. Although as a matter of fact the writers of the century did not always succeed in satisfying these elementary requirements, they had in mind something more than mere mechanical accuracy. The propriety to which they aspired was elegance rather than exactitude. And of such a quality there is evidently no absolute and indisputable standard. The difficulty is insuperable. Beyond a merely mechanic accomplishment to which any one is capable of attaining by study and industry, excellence is altogether a matter of opinion. For the justification of their poetic performance, therefore, they were obliged, in the last resort, to fall back, like any one else, upon the imponderable arbitrament of taste. But taste, while it can not perhaps be argued, may at least be improved and cultivated like any other faculty. Indeed, as the faculty of literary judgment, it depends very largely for its justice upon a knowledge of literature,—not upon a knowledge of this or that author, or this or that period, or even this or that literature, as we seem inclined to believe nowadays, but upon a knowledge of literature as a whole. For Pope and Dryden, however, literature as a whole was represented mainly by Greek and Latin, particularly by the latter; for it is interesting to notice

that modern classicism has always been more Latin than Greek. In their time there existed only one great literary achievement in English, the Elizabethan, comprising two or three poets of considerable magnitude and no such very great number of lesser lights. A man could read through the bulk of it in a few weeks. But this literature was then in discredit by reason of its final extravagances, to say nothing of certain very conspicuous faults even in its greatest writers, faults to which the succeeding age was particularly sensitive without being particularly sympathetic for its stupendous powers. It lay, as a matter of fact, almost wholly outside the tradition of human culture; its parentage and its congenital temper were decidedly medieval;¹ while familiarity and distance had as yet failed to soften its numerous asperities. In the eyes of the humanist who was trying conscientiously to form his taste in accordance with the great tradition of human culture it was thoroughly anomalous and erratic. On the other hand, the literature of contemporary France, which was, besides, in fashion in England for various causes political and social, was just the kind of literature that would appeal to such a critic. It was classical; it was conscious of ancient culture; it was in the great tradition. For these reasons it was likely to encourage him in his distaste of Elizabethanism and to draw his attention to itself and its like away from the literature of his own country. And he was the more confirmed in this error because of the new criticism which was springing up across the channel under the hands of Bossu and Boileau. It has always been one of the fundamental weaknesses of English literature never to know what it wants. And it is, therefore, not astonishing that a criticism such as was produced under Louis XIV. should impose upon a literature like English in making it conscious of its own rather vague aspirations and in supplying it with those definite ideas in which it has always been more or less lacking. As a practical result, what struck the Englishman as good was that which re-

¹"I maintain that our national drama was directly evolved from native antecedents, however indirectly modified through the interest which the Renaissance had awakened in the glories of antiquity." Lewis Campbell. *Tragic Drama in Aeschylus, Sophocles and Shakespeare*.

sembled the French, while he came to look upon Boileau and Rapin—"the latter of which," says Dryden, "is alone sufficient were all other critics lost, to teach anew the rules of writing"¹—very much as the Renaissance had looked upon Aristotle.

"Learn Aristotle's rules by rote,
And at all hazards boldly quote;
Judicious Rymer oft review,
Wise Dennis and profound Bossu."²

Under these circumstances it was inevitable that literature should soon become conventional and imitative. To be sure, every art without exception rests finally upon some convention or other. In this sense, indeed, art is convention. So in drama the action is supposed transparently to take place in a kind of three-sided box, open on the fourth side to the inspection of men and critics. In the same way the ubiquity of reader and author is a necessary postulate of the ordinary novel; while individually the enjoyment of Browning, for instance, depends upon the acceptance of a thoroughly arbitrary dialectic, the so-called dramatic lyric, or lyrical monologue. For this reason, because of some similar convention on which his art necessarily rests, every original genius is likely to strike the unfamiliar reader as strange and unnatural at first. At the same time it is necessary to distinguish. Apparently such a sort of initial convention is by no means inimical to art. Of course its general character and its extent have something to do with the matter. Browning's dramatic lyric is harder to get over than the ordinary dramatic soliloquy. But on the contrary nothing could be more conventional in itself than the English pastoral; and yet Milton's *Lycidas* is a great poem—perhaps his finest if not his greatest. If Pope's Pastorals, therefore, are not good poetry, it is not on this account. It is only when a convention is used, not as a foundation for an effect, but as a substitute for the effect itself, that it becomes a blemish and a source of weakness. Even the unities of time and place, which afford some of the purest examples of con-

¹ Dryden. *The Author's Apology for Heroic Poetry and Poetic License.*

² Swift. *Rhapsody on Poetry.*

vention in literature, are capable in the hands of Racine of the happiest results. But when a convention is nothing more than a symbol, standing for a feeling which it is incapable of expressing, then the writer is no longer a poet but an algebraist. In this way arises the poetic formula, the cant or stock phrase or term, the *cliché*, the circumlocution, which are accepted as poetic regardless what significance they actually possess or whether they possess any significance at all. Such in the eighteenth century was the use of words like "Philomela," "nymph," "urn," the personification of abstractions like "Virtue," the retention of antiquated mythological machinery, the arbitrary distinction between the vocabulary of poetry and prose, the deviousness and indirection of paraphrases like the following:

"With slaughtering guns the unwearied fowler roves
When frosts have whitened all the naked groves;
Where doves in flocks the leafless trees o'ershade,
And lonely woodcocks haunt the watery glade,
He lifts the tube, and levels with his eye:
Straight a short thunder breaks the frozen sky:
Oft, as in airy rings they skim the heath,
The clamorous lapwings feel the leaden death."¹

Even the heroic couplet itself becomes a convention when applied, as it was, to all manner of themes indifferently. By such means as these it is quite possible to write something which will pass for poetry by virtue of rhyme and metre without producing a single genuine poetic effect. And into this sort of thing, it must be confessed that a good deal of the verse of the time resolves.

"A little learning is a dangerous thing!
Drink deep, or taste not the Pierian spring."²

To say nothing of the *cheville*, "Pierian spring" is pure convention; the remainder of these admired lines are plain prose. The illusion of poetry is produced by the nervous agitation of rhyme and measure.

¹ Pope. *Windsor Forest*.

² Pope. *An Essay on Criticism*.

Naturally the use or abuse of such devices is confined to no one particular literary age or group. This is the way in which Shakespeare himself spells poison.

"The leperous distilment, whose effect
Holds such an enmity with blood of man
That swift as quicksilver it courses through
The natural gates and alleys of the body,
And with a sudden vigour it doth posset
And curd, like eager droppings into milk,
The thin and wholesome blood."¹

And even today, when we are still suffocating with righteous indignation against Pope, there is supposed to be some particular virtue resident in words like "fulfill"—

"fulfilled of precious spice,"

and phrasing like

"His eyes were strange and glad and perilous."

Such vices are usually indicative of second-hand inspiration and literary decline. But even so, although they were no more an essential part of the poetic program of the eighteenth century than they are of ours, yet there has probably never been another school so liable to such errors by the very nature of its poetical postulates and theory.

And the same general remark is true also with regard to its character for imitation. The danger of imitation is one that besets every literary movement. After the peculiar conception of art which inspires a particular movement has been thoroughly worked out and brought to all possible perfection, there is nothing left save to repeat the formula indefinitely or else to find a new idea and strike out a new line of development. That is the eternal difficulty of art—its impermanence. After an innovator like Dryden there is still much to be done in carrying out the ideas which he has succeeded in realizing—perhaps recognizing—only partially. After Pope, however, there is nothing for it except imitation or a new school. But this imitation, which is in-

¹ Shakespeare. *Hamlet* I, v.

cidental to the culmination of every art, was rather essential to that of the eighteenth century on account of the character of its fundamental tenets—the dogma of the distinction and fixity of *genres* and the dogma of absolute and permanent literary perfection, survivals both of them of renaissance criticism, for which we have not yet entirely rid ourselves of a certain amount of traditional and superstitious veneration. In accordance with such a faith every after-poet was necessarily a copyist. He could not alter, or he deformed, the *genre*; improvement and modification were alike impossible. At most he could only adapt. Theoretically, therefore, the whole classic movement was an imitation. Practically, however, the English did add something of their own both to the forms and the ideas which they took from others. Their temper was their own, and the conditions which their adaptations had to meet, so that their work has a distinctive tang after all. Their drama, for instance, cramped as it is, is still broader, freer, and bolder than the French, though it is looser, more licentious, and inchoate too. Like most borrowers they were as likely as not to acquire their neighbors' vices without correcting their own. Even their originality is a result of their defects—or at least of their limitations—domestic and foreign, and belongs to their prose rather than to their poetry. In prose, as it happened, they were innovators. But on the whole, consonant as their literary theory was with their mood at the time, they got it, as a conscious possession, from others. Unprompted from without they would probably have never come to literary consciousness at all. At the same time the prompting was opportune and agreeable. In giving shape and solidity to what was floating vaguely in their own minds, it was just the kind of thing to which they were inclined to listen. There is a curious assumption which has worked its way pretty generally into modern criticism, as though the school of Dryden and Pope had been wickedly seduced from their proper allegiance to the Elizabethans by the perfidious misrepresentations of French critics. But as a matter of fact it was the English themselves who helped to raise the prejudice and who threw themselves into the embraces of the stranger because they did not care for Shakespeare and his colleagues. The truth

is that Elizabethanism was on the lees. Its genius had evaporated, leaving its extravagance exposed and impudent. And it was to the example of French literature and the instruction of French criticism that the new age turned for confirmation and support in a reaction whose direction had been fatally determined in that particular sense by internal conditions.

At the same time it must not be forgotten that they borrowed on principle. Only in this way can the extent and bare-facedness of their pilferings be understood or accounted for. It was virtuous to imitate, if not an impeccable antiquity, then those who had appropriated such an antiquity. And in accordance with the same logic by which they had acquired their ideas, they acquired their materials also. What they did not observe was that in doing so they were prolonging, curiously enough, the Elizabethan decadence. It is Fletcher whose name is always in their mouths and in whose footsteps they follow until they finally discover Corneille and Bossu. It may be that their invention was feeble; it was bound to seem so at all events. Even Dryden appears at his best in set exercises, in translation, or in other instances where his theme is given him. "In general," he declares, "the employment of a poet is like that of a curious gunsmith, or watchmaker; the iron or silver is not his own; but they are the least part of that which gives the value: the price lies wholly in the workmanship."¹ And he boldly shoulders the consequences of the theory. His best drama is probably *All for Love*, which is made over from Shakespeare's *Antony and Cleopatra*. With D'Avenant's assistance he applied the same process to the *Tempest*; and with Lee's, to the *Oedipus*, though with less success in both cases. By himself he "accommodated" *Troilus and Cressida*, for the sake of removing "that heap of rubbish under which many excellent thoughts lay wholly buried";² and turned Molière's *l'Etourdi* into *Sir Martin Mar-all*. But his most extraordinary feat was his dramatization of Milton's *Paradise Lost* in heroic couplets under the title of *The State of Innocence and the Fall of*

¹ Dryden. *Preface to an Evening's Love*.

² Dryden. *Preface to Troilus and Cressida*.

Man. To this transmogrification he succeeded in obtaining Milton's consent; but the production was never staged. In addition to all such rehabilitations he translated liberally from Latin, Greek, Italian—and Chaucer. Nor was the case of Pope very different. He inspires himself with Horace and Boileau. A good deal of his best work is a *pastiche* of Latin satire. In the *Essay on Man* he versifies ideas which were furnished him immediately by Bolingbroke and whose significance he did not clearly understand, while most of his pieces seem the result of successive sketches—a various patchwork or mosaic which precludes the notion of original projection. But why multiply examples? When such are the leaders of an age, what can be expected of their followers—of the Crown's and Ravenscroft's, the Gay's and Prior's?¹ Let Addison answer for them all.

“When I have finished any of my speculations, it is my method to consider which of the ancient authors have touched upon the subject that I treat of. By this means I meet with some celebrated thought upon it, or some similitude for the illustration of my subject.”²

In short, the consciousness of the age was what we should now call “literary.” It was haunted by the memory of books, saturated with reminiscences, distracted by the thought of tradition and authority, of rules and models. And even in as far as it succeeded in expressing its own temper, the terms in which it did so were largely second-hand and foreign.

III

But in spite of these sources of weakness and the incidental errors to which they gave rise, or rather on account of the spirit which was liable to such weaknesses—the spirit of order, sobriety, and clearness—it is to this movement that English is indebted for a genuine prose. Of these errors the general character is sufficiently obvious. In their respect for correctness and

¹For examples of imitation on the part of the lesser spirits, see Beljame. *le Public et les hommes de lettres en Angleterre au XVIII^e siècle.* p. 58 ff.

²Addison. *Spectator*, no. 221.

the authority which was supposed to be its sole warrant, the promoters of the movement were apt to become over-anxious and timid; attempting to avoid obscurity and confusion they would run as likely as not into the opposite extreme of obviousness and commonplace; against shallowness and triviality their admiration for precision and lucidity furnished little or no protection; while in their aspiration for elegance and ease they were in danger of completing the mischief by polishing all the freshness and animation out of their work and leaving it insipid and lifeless. And yet, however unfortunate these vices, they were not incompatible with the idea of prose, as were the very virtues of Elizabethanism. In justice to their successors it is only fair to remember that the Elizabethans did not do everything. Dramatic poetry and the shorter, more spontaneous variety of lyric they had brought to an advanced state of perfection. Outside of this field, however, they had done little or nothing. When Ben Jonson attempts to write couplets, the result is lamentable; nor are Shakespeare's own much to brag of, while with prose they had failed signally. As far as their prose had any literary significance at all, it was nothing more or less than de-versified poetry. When Thomas Browne wrote his *Religio Medici*, it was apparently all he could do to refrain from dropping into verse. Rhythm, cadence, the very movement of the language, the mood itself are all poetical—nothing is wanting but metre, and that hardly. Even Milton, who has a prose purpose, is unable to strike the prose note and hold it. Naturally there are one or two exceptions. Thomas Fuller stumbles upon the right track occasionally. Above all, Cowley's essays are thoroughly admirable, though they had no following at the time and have won no appreciation since, probably because his factitious splendor as a poet has eclipsed his genuine merits as a writer of prose. On the whole, however, the predecessors of Dryden lacked a plain prose intention—the sense for a sober, every-day meaning and for a vehicle for its conveyance. And while the need for such a vehicle must have been felt and felt sorely, they seem to have been incapable of distinguishing between the characteristic moods of prose and poetry.¹ With

¹ Matthew Arnold. *The Study of Poetry, Essays in Criticism*, Second Series (Eversley), pp. 37-40.

the poetical qualities of feeling, imagination, and temperament they were generously endowed; of the prose qualities of measure, restraint, precision, and reason they were well-nigh destitute.

Nor is the luster of the achievement diminished by the circumstance that the distinction as once established has been again obliterated. In spite of the havoc and confusion wrought by De Quincey, Ruskin, and Pater, it is the tradition of Addison and Swift which represents, for all their faults, the *genre tranché*, the English prose idea in its integrity. Of this prose, it should be borne in mind, Dryden, however high his deserts, was but the originator. With him prose was very largely a means to end, a matter of business rather than of literature, an instrument for the production of prefaces, dedications, manifestoes, and proclamations of one sort and another incidental to the actual practice of his art in poetry and drama. Had the case been otherwise, had he failed to divest himself of his literary pretension, to begin with, it is doubtful whether his experiments would have turned out very much better than those of his predecessors. As a consequence of his literary *insouciance*, however, his style is naturally very uneven and irregular. He has an official statement to make, a matter of professional business to transact; and he is by no means finical about the manner in which he expresses himself.¹ Nor is it quite fair to expect of him as a beginner that he should thoroughly explore the path upon which he was the first to stumble, or should himself bring his own invention to perfection. For that we must look to a later period, to the period of Swift and Addison.

In the interval, however, though the general conception remains unchanged, the accidental standards have suffered a gradual transformation. Of Dryden's prose the main characteristic is energy. Even at its best it has something of the clumsiness of a bludgeon. In spite of his artlessness and informality it is evident that he still feels written language as something quite different from spoken. By Addison's time, however, conversation has come to be the general standard of prose. For the change the

¹*All for Love*, Preface.

coffee houses, with their assemblage of "wits" and their interminable talk, are in part responsible; but more so, probably, the new comedy, the "comedy of manners," whose dialogue was in reality the only model in existence of a prose at once practicable and literary. But however it happened, the ideals of prose and conversation had become very nearly identical in the minds of Addison and his contemporaries. Not that they wrote exactly as they talked; that was of course impossible. But they aimed to write as they would have liked to talk if they had been able. They tend constantly to obliterate the distinction between the two standards, the literary and the colloquial. Fluency, ease, discursiveness become the *desiderata*. Profundity comes to seem pretentious, even a little absurd. Seriousness itself is in rather bad taste. It is desirable to be suave, agreeable, perspicuous at any price. Such is the false ideal which is mainly accountable for Addison's shallowness and superficiality, for the peculiar listlessness and dejection which are the characteristic effects of his style. His prose is all very pretty, no doubt. One quality of the rarest in English it does at least possess—urbanity. But in the long run it is extremely insipid and cloying.¹

For this reason Swift is to be preferred in many respects to Addison. At his best Swift is neither commonplace nor yet difficult. He is seldom urbane, often very coarse, sometimes very vulgar, occasionally extravagant and fantastical in his pursuit of humor. Above all, he wants balance. With his age and himself he is thoroughly out of tune,—capricious, self-willed, and arrogant. And from his infirmity of temper his style suffers sadly; for as a general thing prose is much more closely affiliated than poetry with character. Vivacity counts for a good deal more in poetry than in prose: about a poetic style there is always something exceptional and factitious; while prose, on the contrary, requires a sustained and regular effort. And yet with all these drawbacks Swift's prose is at its best the best of the period.

Nevertheless, there is this to be said for Addison. It is neither possible nor desirable, perhaps, that a moralist's ideas should be

¹Matthew Arnold. *Literary Influence of Academics; Essays in Criticism*, First Series (Eversley), pp. 64-66.

very new or startling; for his general principles, if not obvious on statement, will carry little or no conviction. His originality will consist in the striking and suggestive application of a small number of universally accepted or acceptable truths. Addison, therefore, is not to be blamed because his ideas are few and familiar. He is to be blamed only as his development of such ideas is otiose or insignificant. When he endeavors, for instance, "to shew how those parts of life which are exercised in study, reading, and the pursuits of knowledge, are long but not tedious, and by that means discover a method of lengthening our lives and at the same time of turning all the parts of them to our advantage,"¹ he starts an interesting and fruitful topic of speculation; while in such illustrations of ordinary moral commonplace as are associated with the names of the *Spectator* and Sir Roger de Coverley, he has laid literature under lasting obligation. But when he spends several pages to prove that a man's acts are not always a sure guide to his character,² then he wastes his own time and abuses his reader's patience.

Half a century later, however, the unrelieved triteness into which this conversational prose finally ran had become thoroughly irksome. By Johnson's day there is a vague suspicion that literature ought, not only to differ from talk, but also to go deeper than talk usually can go. Johnson himself, harking back instinctively to Sir Thomas Browne, attempts more or less deliberately to restore to prose certain of its lost powers by the use of a highly Latinized diction and a highly complicated sentence-structure. In this way he does succeed occasionally in scooping up rather more bottom, and at all events he is always sure of roiling the waters into a passable imitation of profundity. But however clumsy his means, such is undoubtedly the significance of his style. And of this change of opinion nothing can be more indicative than the contrast between his spoken and written language, which is so striking as fairly to justify Macaulay's epigram that when he wrote he did his sentences out of English into

¹ Addison. *Spectator*, no. 94.

² *Ibid.*, no. 257.

Johnsonese. Invariably direct, idiomatic, and incisive in his talk, in his writing he was equally as involved, ponderous, and round-about. "When we were taken upstairs," he writes to Mrs. Thrale in one of his letters from the Hebrides, "a dirty fellow bounced out of the bed in which one of us was to lie." In his published account of the incident as it appears in the *Journey to the Hebrides* the sentence has been transmuted thus: "Out of one of the beds, on which we were to repose, started up at our entrance, a man black as a Cyclops from the forge." Of Buckingham's *Rehearsal* he is said to have remarked that it had not wit enough to keep it sweet, adding after a moment, "It has not vitality enough to preserve it from putrefaction."

In spite of the perplexity which this procedure of his seems to have caused the critics, who are never weary of protesting their amazement that the same man should talk so straight and write so crooked and of fabricating ingenious explanations to account for the mystery, it is perfectly evident what Johnson was driving at. It is perfectly evident in the first place that he drew a very sharp distinction between talk and literary prose. And it is equally evident that he was doing his best to raise that prose from the colloquialism into which it had fallen, and to give it another excellence than that of conversation. In this purpose of enlarging and deepening the content of English prose he was frequently unsuccessful; occasionally, however, he does succeed—at least nearly enough to indicate his intention and suggest the idea to others. And as his contribution to English prose has never been accurately defined or liberally appreciated, it may be worth while to quote at length a significant passage. He is commenting on the remark attributed to Milton that "his vein never happily flowed but from the autumnal equinox to the vernal."

"This dependence of the soul upon the seasons, those temporary and periodical ebbs and flows of intellect, may, I suppose, justly be derided as the fumes of vain imagination. *Sapiens dominabitur astris*. The author that thinks himself weather-bound will find, with a little help from hellebore, that he is only idle or exhausted. But while this notion has possession of the head, it produces the inability which it supposes. Our powers owe much of their energy to our hopes; *possunt quia videntur*. When success seems attainable, diligence is enforced; but when it is admitted

that the faculties are suppressed by a cross wind, or a cloudy sky, the day is given up without resistance; for who can contend with the course of nature?

"From such prepossessions Milton seems not to have been free. There prevailed in his time an opinion that the world was in its decay, and that we have had the misfortune to be produced in the decrepitude of Nature. It was suspected that the whole creation languished, that neither trees nor animals had the height or bulk of their predecessors, and that everything was daily sinking by gradual diminution. Milton appears to suspect that souls partake of the general degeneracy, and is not without some fear that his book is written in *an age too late* for heroic poesy.

"Another opinion wauders about the world, and sometimes finds reception among wise men; an opinion that restrains the operations of the mind to particular regions, and supposes that a luckless mortal may be born in a degree of latitude too high or too low for wisdom or wit. From this fancy, wild as it is, he had not cleared his head, when he feared lest the *climate* of his country might be *too cold* for flights of imagination.

"Into a mind already occupied by such fancies, another not more reasonable might easily find its way. He that could fear lest his genius had fallen upon too old a world, or too chill a climate, might consistently magnify to himself the influence of the seasons, and believe his faculties to be vigorous only half the year.

"His submission to the seasons was at least more reasonable than his dread of decaying Nature, or a frigid zone; for general causes must operate uniformly in a general abatement of mental power; if less could be performed by the writer, less likewise would content the judges of his work. Among this lagging race of frosty grovellers he might still have risen into eminence by producing something which *they should not willingly let die*. However inferior to the heroes that were born in better ages, he might still be great among his contemporaries, with the hope of growing every day greater in the dwindle of posterity. He might still be the giant of the pigmies, the one-eyed monarch of the blind."¹

The passage, though in a sense exceptional, is indicative. It shows Johnson's aim, if not his average achievement. What is extraordinary about it is its chiaroscuro, its evident effort to suggest something more than can be defined and yet to do so without imperilling the common sense and sanity proper to prose. Such echoes as these had not been wakened in English for many a day. "These bursts of light and involutions of darkness; these transient and involuntary excursions and retrocessions of invention"—

¹Johnson. *Lives of the Poets, Milton*.

it is in such terms that he speaks a little later of the intermittent efforts of genius; and the phrasing is presageful of the new order—an order, however, which it was reserved for Burke to establish. And here at last we have the high-water mark of English prose—a prose which is distinct from talk and deeper without being turgid or cumbersome, which is dignified and imposing, and yet flexible and business-like. Faults it has, for English prose always has had and always will have great faults. It is bound to be in extremes of one kind or another; if it is not lacking in spirit, it is subject to *coups de tête*. But at its best Burke's is perhaps the best on the whole that we have in the way of prose as an instrument of thought. It unites the greatest number of powers with the smallest number of failings of any prose in the language. I do not mean to say that Addison's and Swift's are not sometimes better in some respects; but neither of them have the compass of Burke's. Sir Thomas Browne's and DeQuincey's and Ruskin's may have pushed farther in some directions; but they have done so at the expense of their integrity. In short, while this or that author may have excelled or surpassed Burke, acting independently or upon his suggestion, yet he does at least represent in himself the most that prose can do and still remain prose.

IV

While the canon of propriety and correctness, therefore, is not necessarily inimical to poetry, the danger for Dryden and his successors evidently lay in the extremity to which they were likely to push it in the heat of their resentment against what they regarded as the barbaric extravagances of their predecessors. At the same time, however, that, in insisting upon the salutary virtues of moderation and restraint, they would seem to be in equal danger with romanticism of confounding poetry and prose and of reducing all literature, though inversely, to a single standard, the standard of prose, yet as a matter of fact, like every classical coterie, they made a very sharp distinction, perhaps the sharpest that has ever been made in English, between the two—or at least between prose and verse. To be sure, the *differentia* are not very easy to define

and are mostly formal. But it seems clear enough at all events that Dryden still considered poetry to be the more elevated, though he may not have understood very well what poetic elevation really is. Of blank verse he complains that it is less suitable than rhyme for tragedy because it is not sufficiently elevated. "Blank verse is acknowledged to be too low for a poem, nay more for a paper of verses; but if too low for an ordinary sonnet, how much more for tragedy . . . ?"¹ Poetic elevation, then, would seem to depend upon rhyme. Poetry, at all events poetry of a high order, must rhyme. And in conformity with this notion he falls into the habit of calling blank verse prose, "blank verse being," he says, "but measured prose."² "Whether Heroic Verse ought to be admitted into serious plays, is not now to be disputed. . . . All the arguments which are formed against it, can amount to no more than this, that it is not so near conversation as *prose*, and therefore not so natural."

Such was the fatal misconception which resulted in well-nigh shelving blank verse completely for a century and in confirming the general prejudice against Shakespeare as a poet and artist. For if blank verse is no better than prose, what becomes of the poetic pretensions of those who wrote it? And yet, fatuous as the mistake seems to us, it must be remembered in Dryden's excuse, and in that of his contemporaries, that such was the pass to which blank verse had been brought by this time as to make it almost impossible to form a just conception of the measure either in itself or as a basis for an estimate of Shakespeare's versification. For the time being romanticism was thoroughly played out. And although French influence had a good deal to do with the erection of rhyme into an invariable poetic standard, as it had with all the literary positions occupied by English classicism, yet, more important by all odds than any foreign influence was the spirit of opposition that had finally been engendered by the extremity of the age preceding.

Under these circumstances the Heroic Couplet became inevitable, not merely by reason of the encouragement afforded by the

¹Dryden. *An Essay of Dramatic Poesy*.

²*Ibid.*

French Alexandrine, but even more by the very nature of the case. It combined the national line with rhyme; it was the only form of rhyme capable of anything like general application; and especially it suited the kind of subject and effect acceptable to the new poetry. Two lines of ample extent, set off one against the other and yet forming a distinct system in themselves, compact, regular, and symmetrical, capable of antithesis or parallelism—what better vehicle could be imagined for the conveyance of that glorified common sense on which the age prided itself? Nor are its possibilities exhausted by the expression of clear ideas. To do it better justice it is necessary only to think of Professor Santayana's comparison of a Greek colonnade;¹ to recall Thackeray's admiration for the close of the *Dunciad*—lines, he declares, in which Pope "shows himself the equal of all poets of all times";² and to remember that Tennyson had at least one passage of Crabbe by heart:

"Early he rose and looked with many a sigh
 On the red light that filled the eastern sky;
 Oft had he stood before alert and gay,
 To hail the glories of the new-born day:
 But now dejected, languid, listless, low,
 He saw the wind upon the water blow,
 And the cold stream curl'd onward as the gale
 From the pine-hill blew harshly down the dale;
 On the right side the youth a wood survey'd,
 With all its dark intensity of shade;
 Where the rough wind alone was heard to move,
 In this, the pause of nature and of love,
 When now the young are reared, and when the old,
 Lost to the tie, grow negligent and cold—
 Far to the left he saw the haunts of men,
 Half-hid in mist, that hung upon the fen;
 Before him swallows, gathering for the sea,
 Took their short flights and gathered on the lea;
 And near the bean-sheaf stood, the harvest done,
 And slowly blackened in the sickly sun."³

¹Santayana. *Sense of Beauty*, p. 108.

²Thackeray. *English Humourists*.

³Crabbe. *Tales of the Hall*. Book xiii.

Unfortunately, however, in despite of authority or tradition, its defects are not only obvious but are so obnoxious to our present prejudices as to have quite blinded us to its equally obvious merits. It is monotonous, formal, cut and dried, lifeless, wooden, inflexible. Some wit has likened it to the couple of dry sticks which a savage rubs together in hopes of striking a spark. Even its clarity has come to be a reproach. But none the less has our scorn of it cost us a literary *genre* which we can hardly afford to be without. To the expression of a certain kind of wisdom—not altogether unworldly, perhaps, and yet by no means destitute of seriousness and elevation—a composition of pathos, satire, and humor, of the pity and the folly of life, in varying proportions, there is no verse so well adapted. That such a poetry—a poetry of which Pope's *Epistle to Dr. Arbuthnot* is an excellent example—no longer exists in English is probably due to the gradual deformation of the couplet. For just as Dryden misjudged and despised blank verse because he knew it as a living species only in a corrupt and degraded shape, so we, as though in revenge, have mutilated the couplet until its powers are no longer recognizable, and biting off our nose to spite our face, have lost the use of one at least of our literary senses.

“Immersed

In thought so deeply, Father? Sad, perhaps?
For whose sake, hers or mine or his who wraps
—Still plain I seem to see!—about his head
The idle cloak,—about his heart (instead
Of cuirass) some fond hope he may elude
My vengeance in the cloister's solitude?
Hardly † think! As little helped his brow
The cloak then, Father—as your grate helps now!”¹

This is what the heroic couplet has become in our hands. It is nothing but blank verse tagged with rhyme—and poor blank verse at that—a nondescript such as Jonson and Donne wrote, not a distinct measure with its own character and its proper beauty, such as Pope finally brought to perfection. It is the primitive and undifferentiated rudiment from which Dryden began,

¹ Browning. *A Forgiveness*.

and as such it ignores and confounds the labor and the achievement of a century. What wonder that the *genre* for which the couplet was particularly suited should have perished and that poetical satire is dead! The astonishing thing is that now, when men's minds are at last beginning to change, none of our teeming young poets has as yet perceived the possibility of a revival.

But to return to Dryden's conception of poetic excellence. In addition to rhyme poetry must possess mellifluousness. Of all things harshness was most to be reprehended as "Gothic" and barbaric. "Well placing of words for the sweetness of pronunciation," says Dryden, "was not known until Mr. Waller introduced it." His own translation of the first line of the *Iliad* likewise he modestly commends for its smoothness, though it is composed of monosyllables,

"Arms, and the man I sing, who forced by Fate."¹

Without stopping to discuss the quality of this particular verse, we may venture to admit the general contention that poetry ought to be well sounding and that the words ought to be disposed to help the pronunciation and to tickle the ear without injuring the sense, in their natural order withal, and in accordance with the idiom of the language, without violation of grammar or logic. But here it is necessary to make a distinction. The mellifluousness of Dryden and his followers is not to be confounded in the modern manner with melodiousness. There are two kinds of confusion to which modern poetry is particularly liable. On the one hand it is inclined to imitate the illusion of painting by a systematic evocation of visual detail, "vizationalization," so as to produce a sort of verbal or linguistic mirage; on the other hand, that of music by a style of composition in which words are treated rather as notes than ideas.² But for that mellifluousness, that charm of sound proper to language as such, irrespective of purely metrical and musical effects, it has small concern. Not infrequently, indeed, where the musical prepossession is absent, it seems perfectly

¹*Dedication of the Aeneis.*

²Cf. R. L. Stevenson. *Style in Literature: Its Technical Elements*, the latter half.

insensible to cacophony and verbal disorders of every sort, if it does not actually affect them as picturesque or forcible or onomatopoeic in some sense or other.

“Poor vaunt of life indeed,
Were man but formed to feed
On joy, to solely seek and find and feast;
Such feasting ended, then
As sure an end to men;

Irks care the crop-fed bird? Frets doubt the maw-crammed beast?”¹

That is a clatter, a hubbub, a linguistic chaos. In the face of such licentiousness one is bound to believe that art ought to be a little artificial, at all events very artful. And it is upon the legitimate euphony of speech, in contrast with this sort of thing, and not upon musical mimicry, which Dryden insists. Of this property of words he seems, as a matter of fact, to have had some small sense, though to what may be called the intrinsic charm of their associations he is much less responsive. “There is a beauty of sound,” he says, “in some Latin words, which is wholly lost in any modern language”; and he instances “that *mollis amaracus*, on which Venus lays Cupid in the first Aeneid. If I should translate it sweet marjoram, as the word signifies, the reader would think I had mistaken Vergil; for these village words, as I may call them, give us a mean idea of the thing.”²

In the face of this observation it is amusing to find Malone in his edition of Dryden taking the poet to task for just such homely and “village” words as the critic has here been condemning.

“He wrote in general with as much spirit as any man, and in this work, the translation of Vergil, was pressed by other causes to write with yet more rapidity than usual. This must have occasioned several negligences, and among the rest some low expressions and mean lines, sometimes very unworthy of the subject he is treating. Hence he speaks of Bacchus’ honest face and of the jolly Autumn. It is hence that he calls Juno the buxom bride of Jupiter, and Cybele the grandam goddess. It is thus that he speaks of Juno’s sailing on the winds and Apollo’s bestriding the clouds.”

This is turning the tables with a vengeance and out-centuring the century. But the fact is that Dryden had a natural vivacity

¹ Browning. *Rabbi Ben Ezra*.

² Dryden. *Dedication of the Aeneis*.

and exuberance which sometimes carried him beyond his own theories and put his criticism hard to it to follow. For it must be remembered that Dryden had this trait in common with Lessing and other critics who have been writers as well; he criticises from the craftsman's point of view. His criticism is largely a criticism of method. This peculiarity makes it very instructive with regard to the ideas of the time. But naturally enough under the circumstances it is blind to everything outside his own performance, the kind of thing that he was trying to accomplish himself at the moment. In short, he seldom perceives a critical position before he has taken it up poetically. In a sense he furnishes his own data just as he illustrates his own dicta; and all his criticism is self-criticism. Hence his art and his appreciation develop hand in hand. And as he has no hesitation in recording his opinions as fast as they change, his constant development gives his criticism an appearance of inconsistency which is occasionally disconcerting. A poet is expected to grow; he is indulged in half a dozen manners, if necessary. But, unreasonably enough, the critic is expected to form his conclusions once for all and stick to them inflexibly. And yet one of the most praiseworthy, as surprising, things in Dryden's criticism is just this capacity for growth. There is hardly a matter of taste touched in his earlier work with regard to which he has not changed his mind sooner or later for the better, for with regard to his fundamental principles he remains pretty nearly fixed. He comes to have a very much higher opinion of Shakespeare, without relinquishing the original grounds on which he criticised him at first. He reverses his opinion with respect to the relative dramatic merits of the couplet and blank verse without altering his general theory of dramatic poetry, as I shall try to show a little later. And it is very probable that if he had bethought himself he would finally have passed quite another judgment upon "sweet marjoram" and such like "village words" and one more in accord with his own example. But however this may be, it is precisely the fixity of his fundamental principles and the flexibility of his judgment which constitute his merit as a critic.

V

It is obvious from these instances that the school of Dryden and his successors was likely to have scant patience with enthusiasm of any sort. Even in the mouth of Addison, the most liberal, the most open to alien ideas of them all, it is a term of reproach, synonymous with bad taste, license, and extravagance. From their particular point of view poetry was a judicious exercise of the intelligence, not a *rausch* or an intoxication. Substantially it consisted in a neat and epigrammatic way of expressing general truth. And its practitioners probably thought quite as well of their *sententiae* as we do of our "purple patches," and very likely with quite as good reason. In fact, it is difficult to see what other advantage than its modishness Tennyson's *In Memoriam* possesses over Pope's *Essay on Man*, in the eyes of whose contemporaries "reason alone is sufficient to govern a rational creature." In his life of Milton Johnson defines poetry as "the art of uniting pleasure with truth by calling imagination to the aid of reason." And in the same strain he explains genius as "a mind of large general powers accidentally determined to some particular direction."¹ While to like effect Addison laments "the unhappy force of an imagination unguided by the check [*sic*] of reason and judgment." And slight as it is at best, even this apparent concession to imagination is merely nominal, for it must not be forgotten that in the interval the significance of the word has suffered something of a change. In the intention of the eighteenth century, imagination was more nearly identical with what we now think of—if we ever think of it at all—as the constructive faculty, than with that state of ecstatic excitement which is usually signified by the word at present. Whereas the art of writing has finally come of modern times to be associated with the pictorial and the musical arts, it was in those days regarded rather as plastic or structural, while the analogies by which it was illustrated were drawn largely from architecture. Agreeably with this view the literary or poetic imagination was considered to consist mainly in the ability to plan, to conceive a whole through the disposition of

¹ Johnson. *Lives of the Poets*, Cowley.

a number of parts. But this faculty is much more closely allied with intellect, if not identical with it, than is the exaltation of the senses and the emotions upon which vivid pictorial and musical effect depends. In short, ever since the eighteenth century, literature has been becoming less and less intellectual.

Nor, on the other hand, was the eighteenth century familiar with imagination in its older Elizabethan manifestation, which consists at its best, not so much in graphic visualization or seductive melody—though it practices them, too—as in a kind of heightened spiritual perception or penetration which dissolves into its essential unreality the whole world of appearances, together with the very phantasms and eidola by which it succeeds in expressing itself. Compare, for instance, what will undoubtedly be conceded Pope's highest flight, the closing lines of the *Dunciad*:

“She comes! she comes! the sable throne behold
Of night primeval, and of Chaos old!
Before her, fancy's gilded clouds decay,
And all its varying rainbows die away
Thus at her fell approach, and secret might,
Art after art goes out, and all is night.
Nor public flame, nor private dares to shine;
Nor human spark is left, nor glimpse divine!
Lo! thy dread empire, Chaos! is restored;
Light dies before thy uncreating word;
Thy hand, great Anarch! lets the curtain fall,
And universal darkness buries all.”—

compare these lines with the following of Shakespeare's:

“Out, out, brief candle!
Life's but a walking shadow, a poor player
That struts and frets his hour upon the stage
And then is heard no more: it is a tale
Told by an idiot, full of sound and fury,
Signifying nothing.”¹

Such utterances as this were quite out of the way of Pope and his fellows. They are not quite out of our way; there are reverberations of them through the nineteenth century, feeble by com-

¹ Shakespeare. *Macbeth*, V, v.

parison but in the same key. Nothing like them, however, occurs from Dryden to Johnson. The nearest I can think of are things like this:

“Oh had I courage but to meet my fate,
That short dark passage to a future state,
That melancholy riddle of a breath!
That something, or that nothing, after death!”¹

And how remote even this is! The highest flights of the time are, in reality, flights of eloquence rather than of poetry. The close of the *Dunciad* itself is rather eloquent than poetic. And that is the reason, it seems to me, that Dryden has reached points of greater elevation than Pope—because Dryden was naturally eloquent. In some such way as this may be explained the curious similarity of tone as between Dryden and Corneille; for as a general thing eloquence seems to be the noblest modern expression of a strictly classical age or nature.

VI

But though the poetry of the eighteenth century lacked imagination, it possessed one faculty which is sadly to seek at present. It had a very keen sense for ethical ideas. For broad moral generalization, like that of Greek tragedy, it had doubtless little sympathy and still less capacity. There was nothing cosmical about its point of view. But to everything that bore upon the character and the conduct of the individual in society it was very sensitive. And to modern criticism, curiously enough, it is this strong, if limited moral sense which has proved its most disconcerting feature. There is no word more often in the mouths of the writers of the age than the word nature. Nature, they assert, is their standard; it is nature which they pretend to imitate. “First follow nature,” says Pope,² repeating the commonplace of his day. And yet to all appearance, if there is anything in which the century seems deficient, it is a feeling for nature as we understand it.

¹Dryden. *Aureng-Zebe*, v, 1.

²Pope. *Essay on Criticism*, i, 68.

Nor, on the other hand, could anything appear less natural than their language and sentiments. Pope's pastorals, we are told, might have been written by a blind man for all the direct observation they show of the subject; while his vocabulary is about three parts convention and artifice. To account for this apparent discrepancy between profession and practice a great number of explanations have been proposed, some of them ingenious but all more or less unsatisfactory. It has been pointed out that by their own confession nature was nothing but a paraphrase for the imitation of their classics.

"Vos exemplaria Graeca

Nocturna versate manu, versate diurna."¹

"Learn hence for ancient rules a just esteem,
To copy nature is to copy them."²

Or worse, their pretended deference for nature has been treated as an empty formula to which they themselves never thought of attaching any significance, unless it were as a cover for their artificiality. More suggestively, however, Leslie Stephen has observed that the natural, after all, is nothing more or less than the usual.³ What we are used to seems natural, and contrariwise. And in just the same way that it seems natural to an Englishman that a soldier should wear a red coat and unnatural that he should wear any other; so the poetry of Pope, which seems unnatural to us, seemed quite natural to his contemporaries, while our poetry, which seems natural to us, would have seemed unnatural to Pope. And the remark is valuable. On the score of use and wont it disposes of a great part of our charges against the artificiality of the eighteenth century; for I suppose that no one will maintain that Shakespeare's poetry is any more properly a natural product than is Pope's, or that Zola's *Lourdes*, which is the very *decalque* of actuality, is any better literature than Shakespeare's *Midsommer Night's Dream*, which lies outside of the natural altogether. So it is that Dr. Johnson, who is ridiculed for his own artificiality by

¹ Horace. *Ars Poetica*, 268-69.

² Pope. *Essay on Criticisms*, i, 139-40.

³ *English Literature and Society in the Eighteenth Century*.

Lowell,¹ ridicules Cowley on the same score;² while Shakespeare, whom we extol for his naturalness, is denounced for his artificiality by Dryden. In fact, there was never an age that was not artificial to some other and natural to itself. But while this is quite true, Leslie Stephen's suggestion fails to hit the mark. It fails to explain how the poetry of Pope, though it might have seemed natural in this one sense to its *habitués* when once established, should ever have succeeded in recommending itself to any one in the first instance or in justifying its own pretensions as an imitation of nature.

As a matter of fact the difficulty is entirely of our own raising and is due to one of our modern "scientific" confusions. By nature we have come to understand the physical order almost exclusively, the material universe together with the sentient world as far as the latter constitutes a dependency of the former. The natural, therefore, is restricted in our sense to the mechanical and the instinctive or impulsive. Landscape, what was once called "external nature," the animal and the vegetable, are natural still. It is natural apparently to act like a beast; quite unnatural to act like a man. It is in this sense that Renan declares that nature has no regard for chastity—or in other words that chastity is unnatural and hence monstrous.³ As an inevitable consequence it is held almost universally nowadays that such of our institutions and beliefs, moral, social, political, and the like, as can not be accounted for by some purely physical explanation are necessarily idle, illusory, and invalid. Morality must be utilitarian, or it is superstition. And finally it is seriously proposed to apply the methods of "natural" science to the study of society, of history, even of literature and of humanity as a whole, in total forgetfulness apparently that there is another nature than that of natural science. With such notions in our heads it is no wonder if we miss the sense of the eighteenth century. For this conception of nature, in which we have allowed ourselves to become wholly ab-

¹Lowell. *Pope*.

²Johnson. *Lives of the Poets, Cowley*.

³Renan. *Souvenirs d'Enfance et de Jeunesse*. Matthew Arnold. *Discourses in America, Numbers*.

sorbed to the exclusion of any other, the makers of English classicism never possessed at all. The only kind of nature that they knew or cared anything about was human nature. The physical order as such had no particular significance for them. As a subject of literature, and particularly of poetry, it was virtually non-existent. On the one hand they had no scientific turn, and on the other they had no fondness for those vague impressions, those unclear and illimitable suggestions and troubled ideas which we have learned to dote upon in a cloud or a sunset or a hazy mountain prospect. What they were concerned for and what they conceived to be the proper theme of literature, was the human in its characteristic and distinctive manifestations. The dubious affiliations of man with rock, and tree, and stone, the survivals of a remote and bestial parentage, "*la bête humaine*" or *végétale*, the eclipse partial or total of conscience, atavism—all these ambiguous matters that are interesting us so much just at present, they set aside or overlooked altogether. Human nature in its typical aspects, as modified by society and culture, with a well-marked sense for character and conduct, as a moral intelligence, such was their interest and their theme. And on this point the evidence of Dr. Johnson is conclusive.

"But the truth is, that the knowledge of external nature, and the sciences which that knowledge requires or includes, are not the great or the frequent business of the human mind. Whether we provide for action or conversation, whether we wish to be useful or pleasing, the first requisite is the religious and moral knowledge of right and wrong; the next is an acquaintance with the history of mankind, and with those examples which may be said to embody truth, and prove by events the reasonableness of opinions. Prudence and Justice are virtues of all times and of all places; we are perpetually moralists, but we are geometricians only by chance. Our intercourse with intellectual nature is necessary; our speculations upon matter are voluntary and at leisure."¹

Wise and admirable words! The first requisite is the knowledge of right and wrong. Alas! that we should have forgotten it in our lives and have been so eager to substitute in our education such studies exclusively as furnish a knowledge of our material

¹Johnson. *Lives of the Poets, Milton.*

surroundings and a technical dexterity in dealing with them for such as might serve to form the character and control the conduct. And this is the reason that the writings of the eighteenth century would be so salutary for us, if we would only read them. In the prevalence of the industrial idea we have pretty well forgotten that there is such a thing as morality, that life is aught but business or amenable to other than its dingy and dubious standards. To struggle against the current of an entire civilization is impossible; but no less is it wise and wholesome to escape occasionally from an atmosphere of this sort into an age in which every writer was or sought to be a moralist in concerning himself mainly for correct ideas about right living. Dryden, Addison, Swift, Pope—they are all substantially in accord with Dr. Johnson. Of Shakespeare Dryden says: "He needed not the spectacle of books to read nature; he looked inwards and found her there." "The proper study of mankind is man," declares Pope.¹ In this sense every great literature is moral: it is concerned first and foremost for human nature; it is, as Matthew Arnold says, a criticism of life;² and its perusal results in sound ideas about character and conduct. But the literature of the eighteenth century was moral in an even more obvious and didactic sense than this. It was indeed a criticism of life—not in any such metaphorical sense as that in which Matthew Arnold declares Keats' line,

"Forever wilt thou love and she be fair,"

to be a criticism of life,³ but in a very exact and literal sense. They were critical not only in intention but also in method. The poet of the time believed it his duty to analyze and divide, to comment and moralize, to separate the good from the evil and hold them up to contemplation as such, the one to praise and emulation, the other to ridicule and detestation. Hence his poetry was of a strongly disputatious stamp. It was intended to discuss and argue moral questions and was expected to instruct and edify. Even when its purpose is not so patently pedagogical, it is always more or less conscious of some such conception of its poetic function.

¹*Essay on Man*, epistle II.

²*Essays in Criticism*, Wordsworth.

³*Ibid.*

"Since I have raised to myself so great an audience," says Addison, speaking, in this instance as in so many others, for his age in speaking for himself, "I shall spare no pains to make their instruction agreeable, and their diversion useful. For which reasons I shall endeavor to enliven morality with wit, and temper wit with morality, that my readers may, if possible, both ways find their account in the speculation of the day. And to the end that their virtue and discretion may not be short, transient, intermittent starts of thought, I have resolved to refresh their memories from day to day, till I have rescued them out of that desperate state of vice and folly into which the age is fallen."¹

Such is their professed aim with hardly an exception. Even the later novelists lay claim to it. And if the claim is in some cases a pretense, a mere form of words, as it surely is with Fielding and Smollett, even then it shows what a hold the conception had acquired. In fact, it might not be impossible to deduce all the literary forms of the period from this one principle. Even the restoration comedy of manners, from which many of them derive directly or indirectly, though it seems itself to have taken leave of morality entirely, has its roots in the same soil—an interest in the social creature. And if that comedy perished, or rather transmigrated, it did so in part because it had ceased to represent the social being in accordance with the fair sense of the general public regarding him. It would take too long to attempt to trace the affiliations of the various *genres*; but it is easy to observe the moral essay of Addison and the poetic satire assuming certain of the social functions of the comedy of manners as far as that comedy is ideally a criticism of society and transforming them by the admixture of a didactically moral purpose; while it is still easier to detect in Fielding's novel certain other such functions, at the same time that Richardson picks up the Addisonian essay and by a change of proportions, in enlarging the anecdotal and illustrative portions and reducing the critical and discursive, produces *Clarissa Harlowe*. But at all events this one point is clear—the culmination of the movement resulted in a serious confusion of poetical and critical methods. And to this cause is referable in the main the relative inferiority of its poetry.

¹Addison. *Spectator*, no. 10.

Insist upon the imitation of nature as he might, the poet of the eighteenth century never supposed that the imitation of nature, even understanding by nature human or social nature, was the whole story. Such an idea was of much later origin. It has been reserved for naturalism and the late nineteenth century to assert the identity of life and literature. The classical age knew better. Nothing could be clearer than Dryden's recognition of this fundamental distinction; nothing sharper than his discrimination between the foundation and the aim of literature. As for its materials, poetry is to be tried by the closeness of its imitation, that is, by verisimilitude; as for its purpose, that is quite another matter. "It is true that to imitate well is a poet's work; but to affect the soul and to excite the passions; and above all to move admiration, which is the delight of serious plays, a bare imitation will not serve."¹ And it is on this ground exactly, the distinction between life and literature, that he urges the use of the couplet in tragedy. "The converse [conversation] therefore, which 'a poet is to imitate, must be heightened with all the arts and ornaments of poetry; and must be such, as, strictly considered, could never be supposed spoken by any without premeditation."² Upon this point he insists: a tragedy is not life; it is a representation of life from a particular point of view with the aim of producing a particular effect. Accordingly he denies—and the denial is an excellent example of his hard-headed sagacity—he denies explicitly the statement that "a play will be supposed to be a composition of several persons speaking *extempore*."³ On the contrary, he boldly declares, "a play is supposed to be the work of the poet, imitating or representing the conversation of several persons."⁴ Clearly, then, tragedy is not intended to diarize our daily existence, but to "produce," as Goethe says, "the illusion of a higher reality."⁵ What tragedy shall admit, therefore, is to be decided, not by its

¹Dryden. *Defense of an Essay of Dramatic Poesy*.

²*Ibid.*

³Sir Robert Howard. *The Great Favorite or the Duke of Lerma, Preface*.

⁴Dryden. *Defense of an Essay of Dramatic Poesy*.

⁵Goethe. *Wahrheit und Dichtung*, Teil iii, Buch 11.

exact conformity with nature, but by its suitability to the particular purpose. For this reason, because "the plot, the characters, the wit, the passions, the descriptions are all exalted above the level of common converse," Dryden advocates the use in tragedy of the heroic couplet, for, he asks, if "blank verse is acknowledged to be too low for a poem . . . how much more for tragedy?"¹

Such is the position originally taken by Dryden in the great dispute concerning the relative dramatic merits of blank verse and heroic couplets. No doubt his mind was somewhat imposed upon by the example of French tragedy. But it is evident at the same time that his mistaken preference for rhyme is due, not to his misconception of the character of the drama, but to his misconception of the character of blank verse. The question with him always reduced itself to this, that the only possible objection to couplets was their unnaturalness. Where to he replied that tragedy should raise dialogue above the tone of natural conversation, as is perfectly right, and that blank verse was too much like prose to answer the purpose, as was quite wrong. What confirms his general position with reference to tragedy itself is the fact that blank verse has finally been accepted on the very grounds whereon he rejected it, because it is felt as the only measure possessing the requisite loftiness for tragedy. And in fact, as his own understanding of English literature increased and his appreciation of its genius improved, he gave up the couplet himself and took to blank verse more or less successfully. In the beginning, however, it is only fair to remember, he was in reality attempting to produce a kind of illusion quite different from that of Shakespeare and what has turned out to be our traditional poetic drama, and this he succeeded in a sense in doing for a while in the heroic play.

To this extent, then, it seems clear that Dryden and his successors understood what literature is or ought to be. Indeed, one of the most striking characteristics of their period as compared with ours is their strong literary sense. We may have more feeling for "life" and "nature" nowadays, especially for their picturesque

¹Dryden. *An Essay of Dramatic Poesy.*

and panoramic aspects. But as compared with theirs our sense of literature is weak and insecure. At least they read, and they knew the difference between literature and journalism, that close transcription of actuality which forms almost exclusively the present conception of literature. If they imitated anything, it was rather the spectacle of life as it is mirrored in the consciousness of the reflective moral being; and it was the illusion of a moral order so acquired which they tried to reproduce. This illusion—the illusion, in Goethe's words, of a higher reality—is not to be produced by copying our sensations, but by selecting and grouping certain of them into a complete and satisfactory whole in accordance with some idea that the poet has made for himself of their significance and meaning. To be sure, these elements should resemble in some measurable way the materials of experience, though it is a matter of indifference whether they are fact or not. But if he merely reproduce his observations, he will in like manner reproduce only the sensations proper to them, the strained, bewildered sense of actuality; he will produce no illusion at all. His work is valueless; it is true neither in a higher nor a lower sense; it is neither fact nor illusion. A matter is worth saying for either of two reasons: either because it is so or because it is significant. But as the data of a poem are fictitious, the poem itself can not be of value for the former reason. It must, then, depend for its value upon its significance. But it is evident that the only significance which literature can possess must be due to the general conception of life which it embodies; that is, to an idea. Even its verisimilitude, its measurable resemblance to reality, depends rather upon conformity with the idea than upon conformity with fact; "it is a false tendency," says Goethe, "to push the resemblance so far that nothing but a vulgar reality remains."¹ The sense of reality proper to poetry is due mainly to the consistency of the detail with the principle of the poem; that is, it is in part a reflection of the illusion itself and of the general significance of the poem as a whole, for what is intelligible is likely to be mistaken for real. And at the same time and what amounts to much the same thing in the end, it results in part from the self-con-

¹Goethe. *Wahrheit und Dichtung*, Teil iii, Buch 11.

sistency of the detail as it builds up an experience which is again felt as real in as far as it is complete and significant in itself.

Finally, therefore, literature is always a matter of ideas; and since it deals with human life and conduct, a matter consequently of moral ideas. So far it seems perfectly proper with Matthew Arnold to consider poetry a criticism of life. In another aspect, however, the attitude is less satisfactory and is likely to introduce a confusion, the direct contrary of that involved in naturalism or *l'art pour l'art*, but no less serious on that account. For the methods as well as the ultimate aims of poetry and criticism are thoroughly incompatible. The final object of criticism consists in disengaging the idea from the various accidents and circumstances with which it is invested in consciousness and in holding it up to steady contemplation by itself; while the object of poetry, on the contrary, consists in the incorporation of the idea in such a set of accidents and circumstances as will produce a sense of higher or significant reality. In other words, criticism seeks to dispel the illusion which it is the very purpose of poetry to produce. What the latter attempts to embody, the former tries to isolate. And while there is no illusion without an idea to give it significance, there is equally no illusion without some semblance to reality to serve as a foundation. In short, we are poets and romancers by nature, but critics only by profession. While we inform our life with illusion instinctively, our criticism, in a deliberate attempt to see the thing "as in itself it really is," renounces at once illusion and poetry.

Such, however, is the natural consequence of romantic excess. The more irresponsible and sensational a poetry allows itself to become, just so much the more violent is the inevitable classical reaction. Literature is always in extremes. And after a period of dissipation and extravagance, it is only to be expected that Pope and his contemporaries, like Matthew Arnold in our own day, should over-emphasize the critical function of poetry. In recognizing the importance of moral ideas they were doing good service to literature. Their mistake lay in attempting to apply to the treatment of these ideas the methods of criticism rather than those of poetry. In those kinds of poetry which are most nearly

akin to criticism they are accordingly at their best—in the essay and prose generally, which is essentially critical in character, and in the satire and whatever poetry is properly didactic or philosophical. But they seldom produce an illusion, because they fail to give their ideas the form and semblance of reality. Such as they were, however, they corrected our literature of the medievalism which still clung to it, and they established a sound prose tradition for the language in much the same way that Shakespeare may be said to have established our national poetic tradition.

II.—*Statistical Inquiry into the Influence of Credit upon the Level of Prices*¹

BY MINNIE THROOP ENGLAND

Without going into a detailed investigation of the relation between gold and prices, it is assumed that, in the long run, the quantity of gold extant determines the general level of prices. The short-time, violent fluctuations appear to be independent of gold supplies. The task is to determine the relation between credit and these short-time fluctuations. It is the question, "Does business create money, or money create business?" Now it is well known that during every period of prosperity there is a large increase in the amount of credit instruments in use and also an advance in prices; during periods of depression there is a contraction of credit and a fall in prices; but a careful analysis of both credit and prices is necessary in order to determine their causal relations.

The short-time fluctuations which form the familiar crisis cycles of rising then falling prices are, in this discussion, ascribed entirely to changes in the relation of credit to goods. The statistics submitted in the following pages bear out this position. When a rise of prices occurs it is preceded by an expansion of credit as evidenced by the increase in the clearings and loans of the banks. The contraction of credit, either absolute or relative, it is held, causes a fall of prices. This is, apparently, not in harmony with Professor Laughlin's views as set forth in his well-known *Principles of Money*. It is true that he speaks of "the general rise of market prices caused by abnormal credit," yet in

¹The writer wishes to acknowledge the many helpful suggestions and valuable criticisms received from Professor W. G. L. Taylor in the preparation of this article.

another part of his discussion he says that credit exaggerates the movement of market prices, as though there were other forces than credit at work to cause these short-time fluctuations. "The possibility of buying, however, on an enlarged scale by the use of credit, no matter what its perils, exists. It is a means of throwing a vast purchasing power into any one direction; and, as we shall soon see, it is capable of abnormal extension in general. The immediate effect of elation, hopefulness, and prosperity is certain to cause an extension of unsupported or false credit, and to aid in the irregular and extreme movements of market (not normal) prices. Hence the cycles of rising and falling prices are exaggerated by this possible use of credit."¹

It is held with McLeod that prices are determined by the aggregate of money and credit, and that "All credits payable in Gold—whether Bank Notes, Banking Credits, Bills of Exchange, or any others—have identically the same effects on the value of Gold and on Prices as an equal quantity of Gold itself."² At a given moment prices are dependent upon the relation between the quantity of goods on the market and the purchasing power offered for the goods. As far as its effect on prices is concerned, it is maintained that whether this purchasing power consists of coin or credit is a matter of indifference.

To the writer it seems that the major part of the basis for the extension of credit is expected or future production. Professor Laughlin, on the other hand, centers his attention on goods already produced or present goods as the basis. He says: "A typical loan transaction, containing the essentials of all, may be taken by way of illustration. A business firm sells to jobbers on ninety days' time cotton sheetings to the amount of \$10,000. If confined to the actual capital owned by the members of the firm, or company, their operations would be restricted; but if they can borrow of others additional capital, on the strength of the goods they have sold, they can coin the cotton sheetings held by job-

¹Laughlin. *Principles of Money*, 87-88.

²McLeod. *The Theory of Credit*, II, 733. Professor Laughlin says these statements of McLeod's about gold and credit do not seem true. See his *Principles of Money*, 110, footnote.

bers into means of payment, and by purchasing new materials, employ additional labor, and increase their product. The sold goods are used as the basis of a loan at a bank. The bank buys the right to receive \$10,000 ninety days from date; the firm gets the right to draw \$10,000 (less discount) on demand."¹

In harmony with the preceding view of typical credit, Professor Laughlin marks out two funds from which the purchasing power of a country may be derived. These funds are (1) the general wealth in goods and (2) gold and silver. The gold and silver are already in the form of purchasing power, but not all the general wealth in goods, he holds, can be coined into credit, because it is not all bankable property.² No objections can be made to the above except on the ground that the classification is incomplete. There is a third fund of bankable property, viz., goods not yet produced, or future goods. In other words, the total fund from which purchasing power is drawn is not only the general wealth in goods plus the gold and silver, but the goods which are expected to be produced. For example, a new company for mining copper is formed and the shares of the company are placed upon the market. The price of these shares will bear little relation to the amount of wealth in possession of the company, but the price will have direct reference to its expected earning power. The shares represent, therefore, not only present goods but future goods; so when these securities are tendered the bank as collateral for a loan, is it not in reality the goods which are yet to be produced, as well as the goods on hand, that are the basis of the loan?

The use of stock exchange securities as collateral is a very prominent feature of the financial world today, so much so that a loan based upon collateral in the form of securities approaches the typical method of extending credit. The rise of the prices of securities increases the amount of collateral available for loans, and the fall of prices decreases the collateral. The relation between stock exchange prices, credit, and commodity prices—a

¹Laughlin. *Principles of Money*, 79-80.

²*Ibid.*, 112.

phase of the movement of prices which Professor Laughlin has not discussed—is treated at more length in the later discussion.¹

I

THE RISE OF PRICES

Beginning with the lowest point of depression following a crisis, it is found that clearings—a good index of the amount of credit being used in transactions—begin to increase² before commodity prices:

TABLE I
Minimum Point After a Crisis

CRISIS	Clearings Years	Commodity Prices Years
<i>England—</i>		
1866	2	4
1873	3	6
1883	2	4
1890	4	6
Average	2 yrs. 9 mos.	5 yrs.
<i>United States—</i>		
1857	1	3
1873	3	6
1884	1	2
1893	1	4
Average	1 yr. 6 mos.	3 yrs. 9 mos.
<i>Germany—</i>		
1883	1	4

In the United States the average time elapsing after a crisis before clearings improve is 1 year and 6 months, while commodity prices do not begin to rise until 3 years and 9 months.

¹*Cf.* Taylor, W. G. L. *The Influence of Credit on Prices*. Yale Review, August, 1906.

²Obviously, the group which reaches its minimum point at the earliest date is the first to increase. Likewise the group which reaches its maximum first is the first to decrease.

In England the recovery is somewhat slower, 2 years and 9 months for clearings and 5 years for prices. But in the crises here considered, exactly the same time elapses in both countries after the recovery of clearings before prices begin to rise, the average difference being 2 years and 3 months.

Turning to the consideration in more detail of the movement of credit, the bank items for the United States, England, and France are offered:¹

TABLE II
Minimum Point After a Crisis

CRISIS	Note Circulation Years	Deposits Years	Total Circulation and Deposits Years	Loans Years
<i>United States—</i>				
1837.....	6	6	6	6
1848.....	1	1	1	1
1857.....	1	1	1	1
1873.....	4	4	4	5
1884.....	6	0	0	0
1893.....	1	0	0	0
Average.....	3 yrs. 2 mos.	2 yrs.	2 yrs.	2 yrs. 2 mos.
<i>France—</i>				
1804.....	2	1	..	2
1810.....	4	3	3	5
1818.....	..	1	1	2
1825.....	1	4	1	3
1830.....	6	4	6	3
1839.....	2	3	3	5
1847.....	1	0	0	3
1857.....	0	0	0	1
1864.....	0	0	0	4
1873.....	6	0	6	6
Average.....	2 yrs. 5+ mos.	1 yr. 7+ mos.	2 yrs. 2+ mos.	3 yrs. 5- mos.
<i>England—</i>				
1847.....	1	0	0	2
1857.....	0	0	0	1
1866.....	4	3	3	2
Average.....	1 yr. 8 mos.	1 yr.	1 yr.	1 yr. 8 mos.

¹In all the tables *zero* means the crisis year.

Unfortunately the reports for the Bank of England do not give the loans and advances separately after 1875, but include them under the head of "Other Securities." It is quite possible, however, that for the present purpose the amount of securities held is quite as significant as the separate items.¹ For that reason the following table is given, in which it will be noticed that the movement of securities is quite similar after the three crises in which comparisons may be made, to the movements of loans and advances:

TABLE III
Minimum Point After a Crisis.

CRISIS	Note Circulation Years	Private Deposits Years	Total Circulation & Deposits Years	Other Securities Years
<i>England—</i>				
1847.....	1	0	0	2
1857.....	0	0	0	1
1866.....	4	3	3	3
1873.....	..	1	0	3
1883.....	5	-1	4	4
1890.....	4	2	2	4
Average	2yrs.9+mos.	10 mos.	1 yr. 6 mos.	2 yrs. 10 mos.

Comparing the bank items for the three countries, England, France, and the United States, the movement is found to be very similar. Deposits in each case begin to increase before the note circulation. This probably means that hoarded funds are being returned to the bank and that savings are being accumulated. Again, the total credit instruments of the bank, that is, the sum of the circulation and deposits, begin to increase before there is any expansion in loans. This seems to point further to a change from a money to a credit economy; the bank credit in use increases while the transactions of the bank, measured by its loans, are still decreasing.

That during a crisis money, instead of credit, is called for, for the settlement of accounts, is a recognized phenomenon. It is

¹For the composition of "Other Securities," see Palgrave, R. H. I. *Bank Rate and the Money Market*. London, 1903. pp. 27-28.

apparent in the settlement of balances at the clearing houses. The relative amount paid in money increases during crisis times and decreases during good times. The increase is particularly pronounced in the year following the crisis.

TABLE IV
New York Clearing House

CRISIS	Per Cent Paid in Money in Crisis Year	Per Cent Paid in Money in Year after Crisis	Per Cent of Increase
1857	4.4	6.6	50
1873	4.1	5.7	39
1884	4.5	5.1	13

The most familiar manifestation of the demand for money, however, is the falling off of bank reserves during crisis times, but this point need not be gone into for the present purpose.

The next step is to compare the movement of loans and discounts with that of commodity prices. Tables are given for five crises in the United States, six in England, four in France, and one in Germany, making a total of sixteen.

TABLE V
Minimum Point After a Crisis

CRISIS	Loans Years	Commodity Prices Years
<i>United States—</i>		
1848	1	1
1857	1	3
1873	5	6
1884	0	2
1893	0	4
Average	1 yr. 5—mos.	3 yrs. 2+ mos.
<i>France —</i>		
1847	3	0
1857	1	4
1864	4	6
1873	6	6
Average	3 yrs. 6 mos.	4 yrs.
<i>Germany—</i>		
1883	4	4

TABLE V—Continued

CRISIS	Loans Years	Commodity Prices Years
<i>England—</i>		
1847	2	2
1857	1	1
1866	2	4
Average	1 yr. 8 mos.	2 yrs. 4 mos.
<i>England</i> ¹ —		
	Other Securities	
1847	2	2
1857	1	1
1866	3	4
1873	3	6
1883	4	4
1890	4	6
Average	2 yrs. 10 mos.	3 yrs. 10 mos.

The movements again show a striking uniformity. *In each country (except Germany) the loans of the banks increase before a rise in commodity prices occurs.* In every instance except one (France in 1847), loans begin to increase at the same time or earlier than prices. Is it, then, going too far to say that *because* the banks increase their loans, commodity prices begin to rise? Through the extension of loans the purchasing power of the public has been increased; this purchasing power is used to secure commodities, and the enlarged demand for goods causes their prices to rise. *Inflation of prices, then, begins with the increase in the loans of the banks.*

The increase of loans, after a crisis, occurs earliest in the United States, beginning at the expiration of 1 year and 5 months; in England at the end of 2 years and 10 months; in France not until 3 years and 6 months have elapsed. The order is what one would have anticipated: the United States, the most enterprising as well as most speculative, France the most conservative in action, while England occupies the intermediate place.

¹For the same reason as explained concerning tables II and III, two sets of figures are here given for England.

In the United States 1 year and 10 months pass after the extension of loans has begun before commodity prices rise, in England 1 year, while in France commodity prices respond to the extension of loans at the end of 6 months. This difference is probably due to the fact that industry in the United States and England during boom times reaches a stage of much greater activity than it does in France. Overproduction of goods, then, occurs to a greater extent in the former countries, and hence a longer time is required to relieve the overstocked market and create a rise in prices. The difference between France and the other two countries would probably not be so marked if the data for France included the later crises, as, it will be observed, during the earlier period in the United States and England, prices responded more readily to the increase in loans than in the later crises. If the interpretation given be correct, overproduction is, therefore, a more pronounced phenomenon of the later crises.

If inflation takes place through the extension of bank loans and discounts, it is well to ask what are the factors influencing bank expansion. It is, of course, the legitimate business of the bank to furnish a generalized purchasing power to the public, and the bank can prosper financially only in so far as it has that business to do. It, then, is willing to make loans whenever the paper offered it is sound enough, in the estimation of the bank, to warrant it in assuming the position of guarantor. However, it can not, generally speaking, persuade the public to bring paper to the bank for discount, but must wait until the business world sees fit to come of its own accord. After a crisis has been experienced, timidity in all lines of business ventures is the prevailing feature. Business men do not care to give their notes in exchange for goods lest they be unable to meet the obligations when they shall fall due; the holders of goods do not wish to accept notes in payment for goods because they also fear that the obligations will not be met. Exchanges are thus reduced to a minimum, and the deadlock remains until something occurs to inspire business men with a belief that conditions in the future will be such that they will be able to meet newly contracted obligations as they fall due. This stimulus may assume various

forms. It may arise from a good crop; farmers will then have a larger amount of goods to exchange for other kinds of goods, and the factory managers wish to increase their output to meet the new demand. The belief that prosperity is returning may come from the fact that the government has decided to undertake some large enterprise, as canal construction, enlargement of the navy, etc. Whatever the form, any enterprise that calls for increased quantities of goods involves necessarily increased employment for the department of industry that furnishes that particular line of goods.

The belief that the rate of production in the immediate future will be high makes men willing to give their notes in exchange for goods already produced and offered on the market, and it also makes men willing to part with their goods in exchange for such notes. For what is a note but a promise that one will, in the meantime, before the note falls due, produce enough goods to replace with interest the goods which have been advanced by another? Whatever, then, the cause of the belief that times are going to be prosperous, the result is the same: goods begin to change hands, and the exchanges are made possible by the acceptance of the promissory notes. The banks come into use at once by discounting the notes as presented to them, thus giving the holders of the notes an immediate purchasing power. The faith in good times ahead, therefore, is at once evidenced by an increase in the loans and discounts of the banks.

There is, however, another and most important link in the chain of events. It is connected with the stock exchange. Just as soon as the belief arises that business is going to pick up, attention is at once directed to the shares of those companies which it is expected will receive the benefit of the anticipated larger orders or higher prices. The greater earning power of these companies will mean ultimately higher dividends, so that at once the shares of those companies have an increased subjective value. The increased subjective value is immediately registered as a higher market value, because either shares will be held back from the market, or buyers will be more anxious to secure them, and a larger proportion of the purchasing power of the community will be offered for them.

Loans do not usually show an actual increase in amount until after stock exchange prices have risen. In fact, at the time the rise in stock exchange prices occurs, loans are contracting. *However, the absolute amount of loan credit offered for securities at the stock exchange is greater than before, and the loan credit offered for commodities is less in amount, since the total amount of credit in use is the same or less.*¹ Therefore as stock exchange prices rise, commodity prices fall still lower.

The rise in the price of securities is an announcement to the public that men of experience and judgment believe that the earning power of the companies represented in the rise will be increased. This rise has a vital and immediate connection with commodity prices. *Because of the practice of the banks of accepting stock exchange securities as collateral for loans, the rise in the price of securities has immediately and to the amount of the rise increased the power of the community at large to secure loans.* This is rendered the more significant when it is remembered that the rise in the price of securities pertains not only to the shares being actually bought and sold on the stock exchange, but also to securities that are held by investors throughout the entire country.

The extent of the loan inflation which the rise in prices on the stock exchange renders possible is brought out by considering the amount of the rise in security prices during boom times. The following data are suggestive:

¹The importance of the distribution of credit between the securities market (stock exchange) and the commodity market is further shown in the discussion of the fall of prices.

Minnic Throop England

TABLE VI
Rise in Prices of Securities Before a Crisis

CRISIS	Securities	Per cent of Rise
<i>England—</i>		
1866	10 railway shares	46
1873	10 railway shares	60
1890	All leading shares	7
1900	All leading shares	19
<i>United States—</i>		
1884	60 railway stocks	179
1893	60 railway stocks	11
1903	60 railway stocks	109
1903	20 railway stocks	110
1903	12 industrial stocks	74

Inflation is aided, moreover, not only by the rise in the prices of securities, but also in turn by the formation of new companies which offer their securities to the market. The amount of collateral is thereby still further increased. The creation and issuance of capital is, of course, going on all the time, but the rate is greatly accelerated in prosperous periods. Comparing the minimum and maximum years before a crisis, the increase in England and elsewhere of the total amount of capital created and issued was as follows:

TABLE VII
Increase of Capital Applications Before a Crisis

CRISIS	Per cent
1873	530
1883	339
1890	165
1900	236

That the expansion of bank credit is now chiefly due to the practice of the banks advancing credit upon securities is becoming recognized in some small degree. Professor Cleveland says¹ in answer to the question as to what has brought about the remarkable development of bank credit: "The answer must at once come to the mind of any observer of finance that the princi-

¹ Cleveland, F. A. *The Bank and the Treasury*. New York, 1905, pp.6-7.

pal reason for the expansion of deposits (bank credit-accounts) and the accompanying expansion of loans (commercial paper held by banks) is to be found in the great movement which has been the significant feature in financial affairs of the last half dozen years—the movement to aggregate industrial establishments into single great corporate units and to convert the evidence of ownership into corporate securities which have entered actively into the stream of financial operations. Vast amounts of new securities have been created in these half-dozen years, based in a large measure upon properties which were before held as fixed investments by individuals, or, if standing in the form of corporate property, the securities of these corporations were more closely held, and in but small measure entered into the financial operations of the day. This movement—tending to convert evidences of ownership of a great amount of fixed property into a form which has been considered a bank collateral, and which has been made the basis of loans and of corresponding increases or deposits—is undoubtedly the most important single cause for the increase of more than four billion dollars in bank deposits [bank accounts] and bank loans [commercial paper] of the country in the space of three or four years.”

The stock exchange has, therefore, a very immediate connection with commodity prices through increasing the collateral which is available for securing loans. It is no mere coincidence that the rise of stock exchange prices occurs simultaneously with or prior to the increase in loans. The order of improvement for both England and the United States is: (1) stock exchange prices, (2) loans, and (3) commodity prices.

TABLE VIII
Minimum Point After a Crisis

CRISIS	Stock Exchange Prices Years	Loans and Advances Years	Commodity Prices Years
<i>England—</i>			
1857	1	1	1
1866	2	2	4
1883	1	4 ¹	4
1890	3	4 ¹	6
Average	1 yr. 3 mos.	2 yrs. 9 mos.	3 yrs. 9 mos.
<i>United States²—</i>			
1873	4	5	6
1884	0	0	2
1893	0	0	4
Average	1 yr. 4 mos.	1 yr. 8 mos.	4 yrs.

II

THE FALL OF PRICES

What is it, then, that brings the upward movement to a halt? Why do prices not keep on getting higher and higher, *ad infinitum*? The explanation would be comparatively simple if it were found that the order of decline was merely the same as that of the inflation movement, viz., a fall of stock exchange prices and a contraction of loans, followed by a decline of commodity prices. The situation, however, is more complex.

Comparing the movement of commodity prices and clearings, it is found that in some cases commodity prices fall first, and that at other times clearings decrease before prices. In the nine crisis periods presented, prices fell first in four instances, clearings first in four, and both together in the remaining crisis. On the average, the movement of the two approximate each other: in the United States the averages are the same: in England prices fall three months after clearings.

¹Other securities.

²The minimum point of stock exchange prices for the crisis of 1884 is given as the crisis year because the lower points of 1890-91 are clearly connected with the situation preliminary to the crisis of 1893.

TABLE IX¹
Maximum Point Before a Crisis

CRISIS	Commodity Prices Years	Clearings Years
<i>England</i>		
1873	0	0
1883	3	2
1890	-1	0
1900	0	1
Average	6 mos.	9 mos.
<i>United States—</i>		
1857	1	0
1873	1	0
1884	2	3
1893	4	3
1903	0	2
Average	1 yr. 7+ mos.	1 yr. 7+ mos.

In considering the bank items, there appears to be no special significance in the movements of circulation and deposits relative to each other because the one may be substituted for the other. Which shall be used is determined solely by convenience or custom. But in comparing the sum total of the circulation and deposits with the loans, it is found that the former reaches its maximum before the latter. It is in complete harmony with the statement made above in connection with the increase of these bank items that in their relative movements can be traced the transition from a money to a credit economy. In this case, since the circulation and deposits begin to fall off some months before the contraction of loans occurs, the change can be traced from a credit to a money economy. Data for the United States, France, and England are as follows:

¹The minus sign before a number means *after* the crisis.

TABLE X
Maximum Point Before a Crisis

CRISIS	Circulation Years	Deposits Years	Total Circulation and Deposits Years	Loans Years
<i>United States—</i>				
1837.....	0	0	0	0
1848.....	0	0	0	0
1857.....	0	0	0	0
1873.....	0	-1	-1	-2
1884.....	3	2	2	1
1893.....	0	1	1	1
Average....	6 mos.	4 mos.	4 mos.	0
<i>France—</i>				
1804.....	-1	0	..	-1
1810.....	-2	-1	-1	-1
1818.....	..	0	0	0
1825.....	1	0	0	1
1830.....	-2	-1	-1	0
1839.....	-1	1	-1	0
1847.....	1	1	1	0
1857.....	4	5	4	0
1864.....	2	5	2	0
1873.....	0	1	1	0
1882.....	-2	0	0	0
Average....	0	1 yr.	6 mos.	-1+ mo.
<i>England—</i>				
1847.....	2	1	1	0
1857.....	4	4	4	0
1866.....	-2	-2	-2	0
1873.....	..	2	2	1
Average....	1 yr. 4 mos.	1 yr. 3 mos.	1 yr. 3 mos.	3 mos.
<i>England—</i>				
1847.....	2	1	1	Other Securities 0
1857.....	4	4	4	0
1866.....	-2	-2	-2	0
1873.....	..	2	2	0
1883.....	4	4	4	1
1890.....	-3	-1	-1	-1
1900.....	0	4	4	1
Average....	10 mos.	1 yr. 8+ mos.	1 yr. 8+ mos.	1+ mo.

The next and most important step is the comparison of the movement of loans and commodity prices as follows:

TABLE XI
Maximum Point Before a Crisis

CRISIS	Commodity Prices Years	Loans Years
<i>United States—</i>		
1857.....	1	0
1873.....	1	-2
1884.....	2	1
1893.....	4	1
1903.....	0	0
Average.....	1 yr. 7+ mos.	0
<i>France—</i>		
1857.....	1	0
1864.....	0	0
1873.....	1	0
1882.....	2	0
Average.....	1 yr.	0
<i>Germany -</i>		
1883.....	0	2
1891.....	0	1
Average.....	0	1 yr. 6 mos.
<i>England</i>		
1847.....	0	0
1857.....	0	0
1866.....	2	0
1873.....	0	1
Average.....	6 mos.	3 mos.
<i>England—</i>		
1847.....	0	Other Securities 0
1857.....	0	0
1866.....	2	0
1873.....	0	0
1883.....	3	1
1890.....	-1	-1
1900.....	0	1
Average.....	7- mos.	2- mos.

In the United States and France in each case the fall in commodity prices occurs before the contraction of loans; England gives the same average movement, but the crises of 1873 and 1900 in England and 1883 and 1891 in Germany show a reverse order—a contraction of loans and a fall in prices. From these facts the conclusion is reached that *commodity prices frequently fall before the contraction of loans begins, but that the order of*

decline may be reversed. However, before discussing the reason for the order of fall as shown by the above table, it seems best to consider stock exchange prices and their part and place in the downward movement. The following table is offered:

TABLE XII
Maximum Point Before a Crisis

CRISIS	Stock Exchange Prices Years	Commodity Prices Years	Loans and Advances Years
<i>England—</i>			
1857	4	0	0
1866	1	2	0
1890	1	—1	—1 ¹
1900	3	0	1 ¹
Average	2 yrs. 3 mos.	3 mos.	0
<i>United States</i>			
1884	3	2	1
1893	1	4	1
1903	1	0	0
Average	1 yr. 8 mos.	2 yrs.	8 mos.

In table XII there is again an absence of uniform movement, and for this reason the same data are presented in the form of ranks² instead of years, that the movement may be more readily traced.

TABLE XIII
Maximum Point Before a Crisis

CRISIS	Stock Exchange Prices Rank	Commodity Prices Rank	Loans and Advances Rank
<i>England—</i>			
1857	1	2½	2½
1866	2	1	3
1890	1	2½	2½
1900	1	3	2
Total	5	9	10
<i>United States—</i>			
1884	1	2	3
1893	2½	1	2½
1903	1	2½	2½
Total	4½	5½	8

¹ Other securities.

² The class which reaches its maximum point first is designated 1, the next 2, etc. In the crisis of 1857 in England, stock exchange prices

In 1900 in England the decline assumes the simplest form: stock exchange prices begin to decline first; this, as shown above, decreases the amount of possible collateral, and loans are contracted; the contraction of loans decreases the purchasing power available for the commodity market, and the prices of goods fall. This movement is simply the reverse of that which takes place when the transition from depression to boom times occurs. The situation is practically the same in the crises of 1857 and 1890 in England and 1903 in the United States: stock exchange prices fall first and the contraction of loans and commodity prices follows in the same year.

It is of no less interest, however, to inquire what takes place when the above order is not followed as, for example, in the crisis of 1866 in England, when the order of fall is commodity prices, stock exchange prices, and loans. The relation between the fall of stock exchange prices and the contraction of loans is doubtless the same as in the crisis of 1900 already discussed. The remaining question is, Why do prices fall before there is a contraction of loans? The answer that is applicable to this instance will also meet the similar cases presented in table XI. The reason that prices fall at any time is because the supply of goods on the market is relatively greater than the amount of purchasing power offered for the goods. But in boom times, when stock exchange values are high and loans upon this kind of collateral are easily secured, there is no apparent reason why loan extension should not keep pace with or even increase more rapidly than the production of goods so that prices would keep on rising indefinitely. There is theoretically only one limitation to an indefinite expansion of credit, and that is the requirement of guaranty funds in the form of the metals. These, of course, being materialistic, are limited in quantity. But generally, before this natural limitation is reached, the *desire* for goods has been greatly lessened. Many new enterprises have proved disappointing in returns in

reached their highest point first. They therefore receive first rank. Commodity prices and loans reached maximum points during the same year. The remaining ranks 2 and 3 are therefore divided equally between these two classes, giving each a rank of $2\frac{1}{2}$. The same principle is carried out in the later tables where a large number of groups are ranked.

both quantity and price of goods produced. In other words, some industries have failed to produce as many goods as expected, and others have produced as many or more, but it has resulted in overproduction of that particular line of goods with its accompanying low prices. "It is the fact that the great productive organizations have promised more than they can carry out in the way of returns to investment which is the great cause of crises."¹ The decreased subjective value of all goods is at once shown by a *relative* decrease in the demand for credit with which to buy the goods on the market, and their price falls. The principle involved is the same as in the other cases just considered: a contraction of credit and a fall in prices. But in the crisis of 1866, the actual contraction of loans does not take place until prices have fallen. The explanation is as follows:

(1) The number of transactions at a lower price may be so much greater that it may require a larger amount of credit to carry on business than before. The loans of the banks, therefore, continue to increase. This phenomenon occurs frequently on the stock market. There will be a fall in prices, yet a larger sale of shares, so that the total turnover is greater than when prices were higher. In verification of this, the following statistics are offered:

TABLE XIV
New York Stock Exchange

YEAR	Sales of Shares	Average Price
1888.....	65,179,106	62.5
1889.....	72,014,600	61.0
1890.....	71,282,885	60.2
1891.....	69,031,689	57.1
1903.....	161,102,101	73.2
1904.....	187,312,065	69.9

It will be seen that in 1889, 1890, and 1891 as compared with 1888 the sales of shares were larger but the average prices were lower. The same is true of 1904 as compared with 1903.

¹Taylor, W. G. L. *Kinetic Theory of Economic Crises*. Univ. Stud. 4:68, January, 1904.

CHART I

Total Amount of Clearings at London Banker's Clearing House on Stock Exchange Settlement Days and 4th's of the Month



— = 4th's of month
 Figures = Millions of £

- - - - = Stock exchange settlements
 From Statistical Abstract for the United Kingdom

(2) There may have been an absolute decrease in the amount of loan credit offered for commodity goods, even although the loans of the banks were increasing because a growing proportion of the loan credit being given was used, not to purchase goods in the commodity market, but for speculative purposes on the stock exchange.

In support of the second proposition, two charts are offered showing the amount and proportion respectively of clearings at the London Bankers' clearing house on stock exchange settlement days and 4ths of the month. The amount of clearings on stock exchange settlement days is an index of the amount of speculation in progress. The clearings on the 4ths of the month may be taken as representative of business conditions because trade bills are usually made out to fall due the first day of the month, and this, with the custom of adding three days of grace, causes these bills to be cleared on the 4th.¹ The following table is compiled from chart I:

TABLE XV
Maximum Point Before a Crisis

CRISIS	Clearings on 4ths of Month Years	Clearings on Stock Exchange Settlement Days Years
<i>England—</i>		
1873.....	0	-2
1883.....	2	2
1890.....	1	0
1900.....	-1	-1
Average.....	6 mos.	-3 mos.

In each case of the four given, clearings on 4ths of month begin to decrease at the same time with, or prior to, the decline of

¹Beginning with an analysis of chart I, it is found that the general movements of business and speculation (using "business" in the sense of trade bill clearing and "speculation" for stock exchange clearings) are very similar. Both increase during prosperous years and fall off during the years of depression. Stock exchange clearings fluctuate more than the trade bill clearings; *they rise proportionately higher in good times and fall proportionately lower in bad times.* The highest points and lowest points of stock exchange clearings do not always correspond to the highest and lowest points of the trade bill clearings. Following the crisis of

clearings on stock exchange settlement days. On the average, trade bill clearings reach their maximum 6 months before the crisis year, and speculation clearings not until 9 months later. This shows in a striking manner that before a crisis, credit for speculative purposes must form a proportionately larger part of the total credit in use than at other times.

That this point may be brought out still more clearly, the proportion which trade and speculation clearings respectively form of the total clearings is given in chart II. Naturally when the proportion of stock exchange clearings increases, that of trade bills falls off. As has been said, it is significant that trade bill clearings are larger in proportion to the total clearings during the bad years than in the years of "boom" times when the stock exchange clearings mount up enormously in proportion to the total clearings. Thus in the cycle from 1873 to 1883 trade bills reached their highest proportion in 1877, the year the stock exchange clearings were lowest; the highest point of stock exchange clearings was in 1881, the lowest point of trade bills in 1882. During the next cycle, 1883-90, stock exchange clearings formed the largest proportion of the total in 1886, and trade bills the smallest proportion the same year. In the third cycle, 1890-1900, the high point for stock exchange clearings was in 1895, the year of the lowest point in trade bills.

The gist of the matter is this: when loan credit is being used for mere speculative purposes, i. e. for professional buying and selling, so much purchasing power is withheld from the goods market. This is what takes place before each crisis when the gambling spirit comes more and more to the front. In this way the loans of the banks may continually increase, while the actual amount of loan credit offered for goods in the market is decreasing. It is well known that the loans of the banks in New York City are greatly expanded during prosperous times because of

1873, stock exchange clearings reached the lowest point in 1877; after the crisis of 1883, stock exchange clearings touched their lowest point in 1894 and trade bill clearings in 1892, although the latter showed no permanent improvement until 1896—the same year that stock exchange clearings showed a marked increase. We may then say that there is a tendency for stock exchange clearings to begin to increase before trade bill clearings. This lends support to the order of rise of prices as shown in table VIII.

the accommodations given to speculators. The proof of this is strikingly shown at such times by the great increase of clearings in New York City as compared with other sections of the country.

The steps in the fall of prices may be summarized as follows:

(1) The order of decline may be the same as the order of rise. The decline in the subjective value of goods is evidenced by less loan credit being offered for securities. That is, the decline in the subjective value of goods is due to the belief that industries are not going to be as productive as had been expected. If industries are less prosperous smaller dividends will be paid. Since stock exchange prices are based upon expected dividends the prices of securities now fall, thus automatically decreasing the collateral for securing loans. This enforced contraction of loans in turn diminishes the purchasing power offered on the goods market, causing commodity prices to fall. The order of decline in this case is stock exchange prices, loans, commodity prices. (2) The subjective value of goods may have so decreased that although the machinery for securing credit may be intact, i. e. the collateral may be as large in amount as ever through sustained stock prices and the banks may be willing to loan, yet this machinery is not made use of. In this case the order of decline would be a contraction of loans, followed by a fall in stock and commodity prices. By consulting table XIII, it will be seen that in no case does the absolute contraction of loans rank first. Yet this order may conceivably occur. Preceding the reaction of 1900 in the United States, loans reached their maximum point in July, 1899, stock exchange prices in November, 1899, and commodity prices in April, 1900.¹ (3) The third case is similar to the second. The decline in the subjective value of goods decreases the desire to secure loans, but in this case the

¹See *Wholesale Prices 1896 to 1900*, in *Quarterly Bulletin of the Bureau of Economic Research*, October, 1900:38. The stocks used in the preparation of diagram III in the article just cited are twenty-six transportation stocks. It is quite possible that if more comprehensive stock prices were at hand it would be found that stock prices as a whole fell before the contraction of loans, because prices of industrials at this time fell before railroad stocks. Cf. charts 6 and 7 in appendix of the writer's article on *Speculation in Relation to the World's Prosperity 1897-1902*, in *University Studies*, January, 1906.

absolute amount of loan accommodations being given by the banks keeps on increasing. The reason is that the falling off in the demand for credit for the purchase of goods is more than balanced by the demand for credit to be used in speculation. The kind of speculation here referred to makes large demands upon the guaranteeing power of the banks, but creates little demand for goods. For example, the formation of trusts involves large underwriting schemes, but does not necessarily mean enlarged plants or increased production accompanied by a greater demand for raw materials. The order of decline is commodity prices, stock exchange prices, loans.

The fall in prices is, therefore, due first to the decline in the subjective value of goods, shown by a lessened desire to offer credit for goods. This causes a slight and very gradual fall of prices. After the lower subjective value of goods has been registered on the stock exchange by a fall in stock prices, the fall of commodity prices is very greatly accelerated because the *ability* to secure loans, even in the case of those who desire to increase their purchasing power in order to secure goods, has been reduced through the shrinkage of collateral.

III

AN ANALYSIS OF THE MOVEMENT OF COMMODITY PRICES

An investigation of prices would not be complete which did not show just *how* commodity prices as a whole and different classes of commodity prices are affected by the expansion and contraction of credit.

AN ANALYSIS OF GENERAL PRICES

There are many questions that may be asked concerning prices. Is their movement regular? That is, do prices rise continuously until they reach a maximum point and then fall until they reach the minimum? This query is, on the whole, answerable in the affirmative. Any deviations from this rule are apt to be slight and unimportant. The most notable exceptions occur immedi-

CHART II

*Percentage of Total Clearings at London Bankers' Clearing House
Cleared on Stock Exchange Settlement Days and 4th's of the Month*

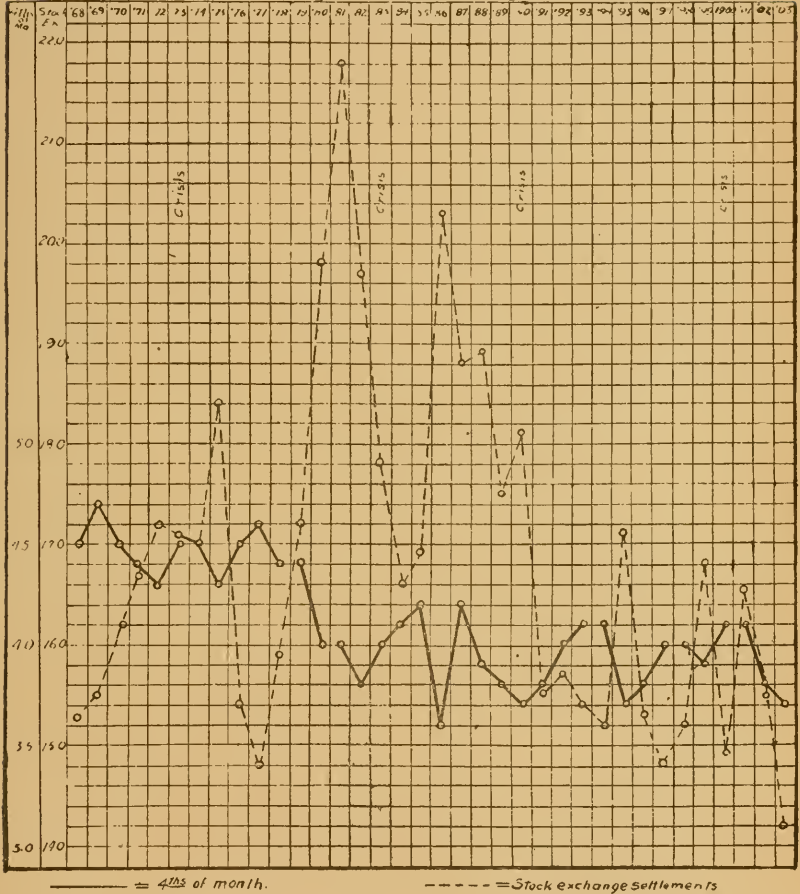

ately following a crisis—in fact, what has been termed a double crisis—that is, an increase in prices followed by a reaction. Prices show less liability to reaction after the later crises than after the earlier ones, as seen in the following table of reactions in prices in England, United States, France, and Germany:

TABLE XVI
Reactions in Prices

CRISIS	England	United States	France	Germany
1847	1851 and 1855-56	1852	1851 and 1854-55	1856
1857	1861	1863 and 1865	1860-61	1861
1864-66	none	none	1870
1873	none	1881	1878-79	1881
1882-84	none	none	none
1890-93	none	1901

Table XVII is designed to give a comprehensive view of the movement of prices in the United States, England, Germany, and France.

The spread of prices¹ is one measure of the severity of the crisis, since the severity is in direct proportion to the amount of speculation going on, and the height to which prices rise is dependent upon the extent of speculation. Naming the countries in the order of the average spread of prices, England has suffered most from crises, France next, followed by the United States and Germany respectively. It is very probable, however, that if the later crises were included in the tables, a different order would be obtained.

The spread of prices at particular crises is important. For the crisis of 1857 the order of greatest spread is England, Germany, the United States, and France. The order for the crisis of 1864-66 is France, England, and Germany. A still different order is obtained for the crisis of 1873: England, the United States, France, and Germany.

Judging from the spread of prices, the crisis of 1873 was much more severe than the crisis of 1857. In the latter case the aver-

¹The spread of prices is obtained by comparing the highest point in prices before the crisis with the lowest point following the crisis.

age spread for the four countries is 12.1 per cent, while for the crisis of 1873 it is 20.6 per cent.

By adding the average time at which prices begin to fall before the crisis, to the average time which elapses after the crisis before prices begin to recover, plus one year for the crisis year, the total period of falling prices is obtained. This depression period is longest in France; the United States is a close second; England comes next in order, and Germany last. For the crisis of 1857 the period of falling prices is 1 year each for England and Germany, 2 years for the United States, and 5 years for France. The crisis of 1864-66 is accompanied by a depression period of 4 years in Germany and 6 years in both England and France. The crisis of 1873 resulted in 6 years of falling prices in England and Germany, and 7 years in the United States and France. The average period of falling prices in the four countries is 6 years and 6 months for the crisis of 1873, and 2 years and 3 months for the crisis of 1857—further evidence that the crisis of 1873 was the more severe one.

In all countries prices are longer in recovering after the later crises than after the earlier ones. In the United States there is also, in the later crises, a tendency for prices to fall earlier than formerly. The period of depression is thus still further lengthened.

TABLE XVII
The Movement of Prices

CRISIS	Maximum Point before Crisis Years	Spread of Prices Per Cent	Minimum Point after Crisis Years
<i>United States—</i>			
1848	1	7.3	1
1857	1	11.6	3
1873	1	24.0	6
1884	2	15.3	2
1893	4	21.2	4
Average	1 yr. 9+ mos.	15.9	3 yrs. 2+ mos.
<i>England—</i>			
1847	0	22.1	2
1857	0	13.3	1
1866	2	8.6	4
1873	0	25.2	6
1883	3	22.7	4
1890	-1	15.2	6
Average	8 mos.	17.8	3 yrs. 10 mos.
<i>Germany—</i>			
1857	0	12.7	1
1866	2	5.7	2
1873	0	15.3	6
1883	0	16.5	4
Average	6 mos.	12.5	3 yrs. 3 mos.
<i>France—</i>			
1857	1	10.8	4
1864	0	19.8	6
1873	1	18.1	6
Average	8 mos	16.2	5 yrs. 4 mos.

AN ANALYSIS OF THE CHIEF CLASSES OF COMMODITIES

Commodities divide themselves into two great classes: raw materials and manufactured goods. One may profitably ask, How are the prices of these classes of goods affected by the speculative extension of credit? Tables XVIII-XIX deal with the order of recovery after a crisis:

TABLE XVIII
Minimum Point in Prices After a Crisis

CRISIS	Manufactures Years	Raw Materials Years
<i>United States</i>		
	Cotton	Cotton
1857.....	1 ³ / ₄	3
1873.....	5 ¹ / ₅	6
1884.....	1 ¹ / ₄	2
1893.....	5	5
Average.....	3 yrs. 3+ mos.	4 yrs.
<hr/>		
	Broadcloth	Wool
1857.....	1	1
1873.....	5	6
Average.....	3 yrs.	3 yrs. 6 mos.
<hr/>		
<i>France—</i>		
	Silk Goods	Silk
1864.....	4	6
1873.....	7	7
1882.....	6	6
Average.....	5 yrs. 8 mos.	6 yrs. 4 mos.
<hr/>		
<i>England—</i>		
	Cotton Cloths	Cotton
1866.....	2	2
1873.....	6	6
1883.....	2	4
Average.....	3 yrs. 4 mos.	4 yrs.

TABLE XIX
Minimum Point in Prices After a Crisis

CRISIS	Raw Materials Years	Half Products of Manufactures Years	Manufactures Years
<i>Germany—</i>			
1873.....	6	6	6

The recovery in the prices of manufactured goods is so uniformly in advance of the recovery in the prices of raw materials that the generalization seems warranted: *after a crisis the prices of manufactures tend to recover before the prices of raw materials.* The increased demand for the finished products, which the rise in prices indicates, is the stimulus for an increase in production, and this causes the rise in the prices of raw materials.

The fall in the prices of these two classes of goods is more irregular than the rise. The expected order would be a falling off in the demand for manufactured goods with its accompanying fall in the price of manufactures, and then the check in production causing the fall in the price of raw materials. This is, as a general rule, what takes place. In the fifteen instances given (tables XX–XXI), there are but four cases in which the prices of raw materials fall first.

TABLE XX
Maximum Point in Prices Before a Crisis

CRISIS	Manufactures Years	Raw Materials Years
<i>United States—</i>		
	Cotton	Cotton
1857.....	0	0
1884.....	3 ² / ₅	3
1893.....	4 ¹ / ₅	3
Average.....	2 yrs. 6+ mos.	2 yrs.
<i>England—</i>		
	Broadcloth	Wool
1857.....	1	¹ / ₂
1884.....	5	4
Average.....	3 yrs.	2 yrs. 3 mos.
<i>England—</i>		
	Cotton Cloths	Cotton
1866.....	2	1
1873.....	3	3
1883.....	2	3
1890.....	0	0
Average.....	1 yr. 9 mos.	1 yr. 9 mos.
<i>France—</i>		
	Silk Goods	Silk
1864.....	-1	-1
1873.....	¹ / ₂	1
1882.....	-1	1
1890.....	0	0
Average.....	-4+ mos.	3 mos.

TABLE XXI
Maximum Point in Prices Before a Crisis

CRISIS	Raw Materials Years	Half Products of Manufactures Years	Manufactures Years
<i>Germany—</i>			
1873.....	0	0	0
1883.....	3	2	0
Average.....	1 yr. 6 mos.	1 yr.	0

The figures for the spread of prices agree that *the prices of manufactured goods are more stable than the prices of raw materials*.¹ The formation of trusts among manufacturers has doubtless had much to do with the steadying of prices in the case of manufactured goods. For example, a uniform price for broadcloth² is maintained from 1884 to 1891 inclusive, but the price of wool fluctuates greatly within that period. It is sometimes said that trusts are able to maintain prices for a time at a higher level than under freer competitive conditions, but that when the fall of the prices of trust commodities does occur, the decline is greater than that of competitive prices. The data here given do not lend support to this view.

In the crisis of 1873 in Germany, it was the half-products of manufactured goods which showed the greatest spread of prices.

TABLE XXII
Spread of Prices

CRISIS	Manufactures	Raw Materials
	Per Cent	Per Cent
<i>United States—</i>	Cotton	Cotton
1857.....	7.0	18.6
1873.....	50.2	50.7
1884.....	23.4	22.8
1893.....	38.6	46.3
Average.....	29.8	34.6
	Broadcloth	Wool
1857.....	15.6	21.9
1873.....	18.7	50.9
1884.....	10.6	35.2
Average.....	15.0	36.0
<i>England—</i>	Cotton Cloths	Cotton
1866.....	60.2	71.9
1873.....	34.3	58.9
1883.....	17.1	29.8
Average.....	37.2	52.2
<i>France—</i>	Silk Goods	Raw Silk
1864.....	2.7	11.1
1873.....	27.9	38.7
1882.....	30.5	25.9
Average.....	20.4	25.2

¹Cf. Giffen, R. *Economic Inquiries and Studies*, London, 1904. 1:81-3.

²See Appendix, table U.

TABLE XXIII
Spread of Prices

CRISIS	Raw Materials Per Cent	Half Products of Manufactures Per Cent	Manufactures Per Cent
<i>Germany—</i> 1873.....	19.6	38.1	19.4

English prices are conveniently summarized under the heads of food and materials. A comparison of these two important classes shows that, on the average, prices of materials both rise and fall before food prices, but that the spread of prices is greatest in the case of food. In considering the crises separately, exceptions to this order will be noted. The early rise and fall of the prices of materials is to be explained by the changes in *demand* for such commodities. There is comparatively little difference in the rate of production between good and bad times. The crisis is essentially a psychic phenomenon. On the other hand, the demand for food is more constant and the fluctuations in food prices are due more to changes in *supply*. The general rise and fall of food prices seems also related to crises chiefly as a causal movement. This point is brought out more fully later in the discussion.

TABLE XXIV
Minimum Point of Prices After a Crisis by Ranks

CRISIS	Total Food	Total Materials
<i>England—</i>		
1847.....	2	1
1857.....	1½	1½
1866.....	2	1
1873.....	1½	1½
1883.....	2	1
1890.....	1	2
Total	10	8
Final Rank.....	2	1

Maximum Point of Prices Before a Crisis by Ranks

1857.....	1½	1½
1866.....	2	1
1873.....	2	1
1883.....	1½	1½
1890.....	1	2
1900.....	1½	1½
Total	9½	8½
Final Rank.....	2	1

Spread of Prices by Ranks

1857.....	1	2
1866.....	2	1
1873.....	2	1
1883.....	1	2
1890.....	1	2
Total	7	8
Final Rank.....	1	2

AN ANALYSIS OF GROUPS OF COMMODITIES

The investigation now deals with the movement of prices in England, Germany, and the United States by groups of commodities.

A. A General Analysis

The recovery of prices is first taken up. The minimum points of prices are given in years; then, that the order of recovery may stand out more clearly, the same facts are also presented in the form of ranks. It seems best to present the data for the rise, fall, and spread of prices before the interpretation of these facts

is attempted. The movement of the one throws light upon the others.

TABLE XXV
Minimum Point of Prices After a Crisis

CRISIS	Vegetable Food Years	Animal Food Years	Sugar Tea & Coffee Years	Total Food Years	Minerals Years	Textiles Years	Sundry Materials Years	Total Materials Years
<i>England—</i>								
1847.....	4	3	1	4	4	1	2	1
1857.....	7	1	4	1	4	1	8	1
1866.....	4	2	0	4	2	5	4	2
1873.....	6	6	6	6	6	6	6	6
1883.....	4	4	3	4	2	3	4	3
1890.....	6	6	8	6	5	7	7	7

TABLE XXVI
Minimum Point of Prices After a Crisis

CRISIS	Food Years	Clothing Years	Fuel and Lighting Years	Metals & Implements Years	Lumber and Building Materials Years	Drugs and Chemicals Years	House Furnishing Goods Years	Miscellaneous Years
<i>United States—</i>								
1848.....	1	1	4	2	3	5	4	4
1857.....	6	4	6	8	8	3	8	6
1873.....	6	6	5	6	6	3	6	3
1884.....	1	1	2	5	1	3	3	3
1893.....	3	4	1	5	4	2	4	3

TABLE XXVII
Minimum Point of Prices After a Crisis

CRISIS	Agricultural Products Years	Animal Products Years	Tropical Etc. Years	East India Goods Etc. Years	Minerals and Metals Years	Textile Materials Years	Divers Years	British Exports Years
<i>Germany—</i>								
1857.....	7	6	7	1	5	1	1	1
1866.....	4	1	3	1	2	5	3	5
1873.....	5	6	3	3	6	7	6	8
1883.....	4	5	1	3	3	4	5	5

TABLE XXVIII
Minimum Point of Prices After a Crisis by Ranks

CRISIS	Vegetable Food	Animal Food	Sugar Tea and Coffee	Minerals	Textiles	Sundry Materials
<i>England—</i>						
1847.....	5½	4	1½	5½	1½	3
1857.....	5	1½	3½	3½	1½	6
1866.....	4½	2½	1	2½	6	4½
1873.....	3½	3½	3½	3½	3½	3½
1883.....	5	5	2½	1	2½	5
1890.....	2½	2½	6	1	4½	4½
Total.....	26	19	18	17	19½	26½
Final Rank..	5	3	2	1	4	6

TABLE XXIX
Minimum Point of Prices After a Crisis by Ranks

CRISIS	Food	Clothing	Fuel and Lighting	Metals & Implements	Lumber and Building Materials	Drugs and Chemicals	House Furnishing Goods	Miscellaneous
<i>United States—</i>								
1848.....	1½	1½	6	3	4	8	6	6
1857.....	4	2	4	7	7	1	7	4
1873.....	6	6	3	6	6	1½	6	1½
1884.....	2	2	4	8	2	6	6	6
1893.....	3½	6	1	8	6	2	6	3½
Total.....	17	17½	18	32	25	18½	31	21
Final Rank..	1	2	3	8	6	4	7	5

TABLE XXX
Minimum Point of Prices After a Crisis by Ranks

CRISIS	Agricultural Products	Animal Products	Tropical Etc.	East India Goods Etc.	Minerals and Metals	Textile Materials	Divers	British Exports
<i>Germany—</i>								
1857.....	7½	6	7½	2½	5	2½	2½	2½
1866.....	6	1½	4½	1½	3	7½	4½	7½
1873.....	3	5	1½	1½	5	7	5	8
1883.....	4½	7	1	2½	2½	4½	7	7
Total.....	21	19½	14½	8	15½	21½	19	25
Final Rank..	6	5	2	1	3	7	4	8

To summarize, the order of rise of prices in England is minerals, sugar, tea and coffee, animal food, textiles, vegetable food,

and sundry materials. In the United States food is first to rise, followed in order by clothing, fuel and lighting, drugs, miscellaneous, building materials, house furnishing goods, and lastly metals and implements. The order in Germany is East India goods, tropical products, minerals and metals, divers, animal products, agricultural products, textiles, and British exports.

The fact that commodities in the three countries are not grouped the same makes comparison difficult. Yet this much is evident, that the order of rise is different for each country and for each crisis. There are, however, three of the most important groups in each country which approximate the groupings of the other countries and can for that reason be compared. For example, the "minerals" of England correspond to the "metals and implements" of the United States, and the "minerals and metals" of Germany. The other two groups are foods and textiles.

TABLE XXXI

Minimum Point of Prices of Three Classes of Commodities by Ranks

CRISIS	Vegetable Food	Minerals	Textiles
<i>England—</i>			
1847.....	2½	2½	1
1857.....	3	2	1
1866.....	2	1	3
1873.....	2	2	2
1883.....	3	1	2
1890.....	2	1	3
Total	14½	9½	12
Final Rank.....	3	1	2
<i>United States—</i>			
1848.....	1½	3	1½
1857.....	2	3	1
1873.....	2	2	2
1884.....	1½	3	1½
1893.....	1	3	2
Total	8	14	8
Final Rank.....	1½	3	1½
<i>Germany—</i>			
1857.....	3	2	1
1866.....	2	1	3
1873.....	1	2	3
1883.....	2½	1	2½
Total	8½	6	9½
Final Rank.....	2	1	3

The fall of prices, given first by years and then by ranks, takes place as follows:

TABLE XXXII
Maximum Point of Prices Before a Crisis

CRISIS	Vegetable Food Years	Animal Food Years	Sugar Tea & Coffee Years	Total Food Years	Minerals Years	Textiles Years	Sundry Materials Years	Total Materials Years
<i>England—</i>								
1857.....	2	0	0	0	3	0	0	0
1866.....	-1	1	2	-1	2	2	-2	2
1873.....	0	0	0	0	0	.1	1	1
1883.....	3	1	3	3	1	3	3	3
1890.....	2	1	1	1	0	1	-1	0
1900.....	2	-2	0	0	0	0	-2	0

TABLE XXXIII
Maximum Point of Prices Before a Crisis

CRISIS	Food Years	Clothing Years	Fuel and Lighting Years	Metals and Implements Years	Lumber & Building Materials Years	Drugs and Chemicals Years	House Furnishing Goods Years	Miscellaneous Years
<i>United States—</i>								
1848.....	1	4	3	1	1	2	0	0
1857.....	0	0	1	3	3	1	2	1
1873.....	2	1	1	1	1	-1	2	2
1884.....	1	4	1	4	2	7	4	1
1893.....	4	7	4	2	7	4	2	2
1903.....	1	3	0	3	0	3	0	1

TABLE XXXIV
Maximum Point of Prices Before a Crisis

CRISIS	Agricultural Products Years	Animal Products Years	Tropical Etc. Years	East India Goods Etc. Years	Minerals and Metals Years	Textile Materials Years	Divers Years	British Exports Years
<i>Germany—</i>								
1857.....	2	0	0	0	0	0	3	0
1866.....	-1	0	-1	2	2	2	2	2
1873.....	-1	-2	-1	-1	0	1	1	1
1883.....	0	0	3	6	3	1	1	0
1891.....	0	0	0	1	0	2	1	2

TABLE XXXV
Maximum Point of Prices Before a Crisis by Ranks

CRISIS	Vegetable Food	Animal Food	Sugar Tea and Coffee	Minerals	Textiles	Sundry Materials
<i>England—</i>						
1857.....	2	4½	4½	1	4½	4½
1866.....	5	4	2	2	2	6
1873.....	4½	4½	4½	4½	1½	1½
1883.....	2½	5½	2½	5½	2½	2½
1890.....	1	3	3	5	3	6
1900.....	1	5½	3	3	3	5½
Total.....	16	27	19½	21	16½	26
Final Rank	1	6	3	4	2	5

TABLE XXXVI
Maximum Point of Prices Before a Crisis by Ranks

CRISIS	Food	Clothing	Fuel and Lighting	Metals and Implements	Lumber & Building Materials	Drugs and Chemicals	House Furnishing Goods	Miscellaneous
<i>United States—</i>								
1848.....	5	1	2	5	5	3	7½	7½
1857.....	7½	7½	5	1½	1½	5	3	5
1873.....	2	5½	5½	5½	5½	8	2	2
1884.....	7	3	7	3	5	1	3	7
1893.....	4	1½	4	7	1½	4	7	7
1903.....	4½	2	7	2	7	2	7	4½
Total.....	30	20½	30½	24	25½	23	29½	33
Final Rank	6	1	7	3	4	2	5	8

TABLE XXXVII
Maximum Point of Prices Before a Crisis by Ranks

CRISIS	Agricultural Products	Animal Products	Tropical Etc.	East India Goods Etc.	Minerals and Metals	Textile Materials	Divers	British Exports
<i>Germany—</i>								
1857.....	2	5½	5½	5½	5½	5½	1	5½
1866.....	7½	6	7½	3	3	3	3	3
1873.....	6	8	6	6	4	2	2	2
1883.....	7	7	2½	1	2½	4½	4½	7
1891.....	6½	6½	6½	3½	6½	1½	3½	1½
Total.....	29	33	28	19	21½	16½	14	19
Final Rank	7	8	6	3½	5	2	1	3½

The order of price decline in England takes the form, vegetable food, textiles, sugar, tea and coffee, minerals, sundries and animal food. Clothing, in the United States, is first to fall, then drugs, metals, building materials, house furnishing goods, food, fuel, and miscellaneous articles. In Germany divers articles fall first, then textiles (the three countries agree in an early fall of textiles), East India goods and British exports fall together, followed in turn by minerals, tropical products, agricultural products, and lastly animal products.

Here again in the fall of prices, it seems impossible to detect any characteristic order. It is the continued fall of the general level of prices and not the fall of any group of commodities which is prophetic of the approach of a crisis.

TABLE XXXVIII
Maximum Point of Prices of Three Groups of Commodities by Ranks

CRISIS	Vegetable Food	Minerals	Textiles
<i>England—</i>			
1857.....	2	1	3
1866.....	3	1½	1½
1873.....	2½	2½	1
1883.....	1½	3	1½
1890.....	1	3	2
1900.....	1	2½	2½
Total.....	11	13½	11½
Final Rank.....	1	3	2
<i>United States—</i>			
1848.....	2½	2½	1
1857.....	2½	1	2½
1873.....	1	2½	2½
1884.....	3	1½	1½
1893.....	2	3	1
1903.....	3	1½	1½
Total.....	14	12	10
Final Rank.....	3	2	1
<i>Germany—</i>			
1857.....	1	2½	2½
1866.....	3	1½	1½
1873.....	3	2	1
1883.....	3	1	2
1891.....	2½	2½	1
Total.....	12½	9½	8
Final Rank.....	3	2	1

In the fall of the leading groups common to the three countries, the United States and Germany show the same order of decline. In England, however, food prices fall first instead of last as in the former countries.

The greatest interest attaches to the spread of prices, for the direction which speculation has taken is here revealed to a great extent. Both percentages and ranks are given.

TABLE XXXIX
Spread of Prices

CRISIS	Vegetable Food Per ct.	Animal Food Per ct.	Sugar Tea & Coffee Per ct.	Total Food Per ct.	Minerals Per ct.	Textiles Per ct.	Sundry Materials Per ct.	Total Materials Per ct.
<i>England—</i>								
1857.....	34.2	6.8	19.3	13.7	20.9	8.7	18.5	12.1
1866.....	23.5	9.3	11.3	7.9	11.5	36.4	2.9	16.8
1873.....	17.9	13.8	17.9	15.9	48.3	35.1	21.3	32.2
1883.....	28.1	24.0	31.8	25.5	16.4	22.2	24.7	20.2
1890.....	20.9	15.1	32.0	17.3	22.5	27.1	10.1	16.9

TABLE XL
Spread of Prices

CRISIS	Food Per ct.	Clothing Per ct.	Fuel and Lighting Per ct.	Metals & Implements Per ct.	Lumber and Building Materials Per ct.	Drugs and Chemicals Per ct.	House Furnishing Goods Per ct.	Miscellaneous Per ct.
<i>United States—</i>								
1848.....	16.6	22.4	61.0	4.8	10.2	13.6	8.0	20.0
1857.....	22.0	10.5	41.6	29.5	26.2	26.2	30.9	26.8
1873.....	36.2	30.5	33.0	24.6	24.8	18.1	40.9	24.6
1884.....	16.9	18.8	24.5	24.3	7.9	27.4	22.1	24.5
1893.....	30.7	21.7	18.0	22.7	19.8	17.6	18.5	18.3

TABLE XLI
Spread of Prices

CRISIS	Agricultural Products Per ct.	Animal Products Per ct.	Tropical Etc. Per ct.	East India Goods Etc. Per ct.	Minerals and Metals Per ct.	Textile Materials Per ct.	Divers Per ct.	British Exports Per ct.
<i>Germany—</i>								
1857....	25.8	11.4	35.4	19.7	18.2	7.6	16.5	.3
1866....	10.3	2.2	8.6	9.0	12.3	17.5	39.7	16.3
1873....	12.2	13.2	11.3	5.1	40.0	22.8	29.8	20.8
1883....	32.6	17.5	22.3	11.4	20.2	23.2	25.0	9.4

Minnie Throop England

TABLE XLII
Spread of Prices by Ranks

CRISIS	Vegetable Food	Animal Food	Sugar Tea and Coffee	Minerals	Textiles	Sundry Materials
<i>England—</i>						
1857.....	1	6	3	2	5	4
1866.....	2	5	4	3	1	6
1873.....	4½	6	4½	1	2	3
1883.....	2	4	1	6	5	3
1890.....	4	5	1	3	2	6
Total.....	13½	26	13½	15	15	22
Final Rank	1½	6	1½	3½	3½	5

TABLE XLIII
Spread of Prices by Ranks

CRISIS	Food	Clothing	Fuel and Lighting	Metals & Implements	Lumber and Building Materials	Drugs and Chemicals	House Furnishing Goods	Miscellaneous
<i>United States—</i>								
1848.....	4	2	1	8	6	5	7	3
1857.....	7	8	1	3	5½	5½	2	4
1873.....	2	4	3	6½	5	8	1	6½
1884.....	7	6	2½	4	8	1	5	2½
1893.....	1	3	7	2	4	8	5	6
Total.....	21	23	14½	23½	28½	27½	20	22
Final Rank	3	5	1	6	8	7	2	4

TABLE XLIV
Spread of Prices by Ranks

CRISIS	Agricultural Products	Animal Products	Tropical Etc.	East India Goods Etc.	Minerals and Metals	Textile Materials	Divers	British Exports
<i>Germany—</i>								
1857....	2	6	1	3	4	7	5	8
1866....	5	8	7	6	4	2	1	3
1873....	6	5	7	8	1	3	2	4
1883....	1	6	4	7	5	3	2	8
Total.....	14	25	19	24	14	15	10	23
Final Rank	2½	8	5	7	2½	4	1	6

Arranging the commodity groups in order according to the spread of prices, those of greatest spread coming first, and so on,

the following ranking is obtained: In England vegetable food and sugar, tea and coffee come first with the same rank, minerals and textiles come next with equal ranks, then sundries, and lastly animal food. In the United States the order is fuel and lighting, house furnishings, food, miscellaneous articles, clothing, metals, drugs, and building materials. Germany observes the order, divers, next metals and agricultural products with equal rank, then textiles, tropical products, British exports, East India goods, and animal products.

In the spread of prices, the three great groups, food, minerals, and textiles come uniformly to the front. These are clearly the commodities which, under this test, are affected most by crises. It is easy to understand why this should be the case. Minerals and metals are basic products. There are few or no enterprises which do not make some demands upon them. "Iron being wanted for almost every industry is the one of them upon which the misfortunes of all other industries ultimately fall. If the cotton trade is bad, the cotton spinners require less machinery. If the mineral trade is bad, the railroads require a smaller amount of accommodation; fewer rails are required and less rolling stock. And the same observation applies with regard to ships."¹

The tendency for the prices of textiles to spread greatly shows the extent of speculation in that line. It is possible also that overproduction takes place in the textile industries more readily than in others. In other words, when a financial pressure is being experienced the most drastic economies take place in expenditures for clothing. These industries would also be apt to suffer from wrong estimates of consumption because they come into intimate contact with all the caprices of fads and fashions. In addition, the raw materials used in manufacturing textiles are, like food products, dependent very directly upon the seasons. This would increase the tendency to price fluctuations.

The spread in the prices of food products, as stated above, must be regarded as an occasion of crises. Food products do not enter into schemes of promotion, but they are objects of increas-

¹Testimony of Sir Lowthian Bell, in *Second Report of Royal Commission on Depression of Trade*, Q. 1924.

ing speculation in the goods market. In any case a slump in that market due to a change in the relation of supply and demand must occasion a general crisis that was already prepared in the securities market. This is most in evidence in agricultural countries like the United States where a crop failure frequently causes a break in a situation already under great tension. Likewise, it is well known that the rise in the price of food products in the United States because of an increased foreign demand is not infrequently the stimulus which sets a "boom" in motion. "A good or bad wheat harvest probably makes more difference with the general prosperity of the country than all the tariff legislation put together."¹

The spread of prices of the three common groups relative to each other is shown by the following tables:

TABLE XLV
Spread of Prices of Three Groups of Commodities by Ranks

CRISIS	Food	Minerals and Metals	Textiles
<i>England—</i>			
1857.....	1	2	3
1866.....	2	3	1
1873.....	3	1	2
1883.....	1	3	2
1890.....	3	2	1
Total	10	11	9
Final Rank.....	2	3	1
<i>United States—</i>			
1847.....	2	3	1
1857.....	2	1	3
1873.....	1	3	2
1884.....	3	1	2
1893.....	1	2	3
Total	9	10	11
Final Rank.....	1	2	3
<i>Germany—</i>			
1857.....	1	2	3
1866.....	3	2	1
1873.....	3	1	2
1883.....	1	3	2
Total	8	8	8
Final Rank.....	2	2	2

¹Ed. *Yale Review*. 1:233, November, 1892.

Summarizing the data for the three groups of commodities for the three countries, England, Germany, and the United States, it is found that on the average minerals and metals are the first to rise in price; the decline begins with textiles; the greatest spread of prices is in food products.

TABLE XLVI
Minimum Points of Prices by Ranks

COUNTRY	Food	Minerals and Metals	Textiles
England	3	1	2
Germany	2	1	3
United States	1½	3	1½
Total	6½	5	6½
Rank	2½	1	2½

Maximum Points of Prices

England	1	3	2
Germany	3	2	1
United States	3	2	1
Total	7	7	4
Rank	2½	2½	1

Spread of Prices

England	2	3	1
Germany	2	2	2
United States	1	2	3
Total	5	7	6
Rank	1	3	2

The general impression made by these figures is that food prices are a cause rather than an effect of crises; and that promotion of a line of production, such as textiles, tends to cause prices in that line to *fall earlier than other prices and to recover again only after other prices have recovered*; and again that *the prices that fluctuate most are not those that fall last and rise first, but, on the contrary, those that fall first and rise last*. On the whole, textiles show this tendency more than minerals.

B. A Detailed Analysis

Tables XLVII–XLIX are designed to furnish a comprehensive view of the movement of group prices during each crisis. The fall and recovery of prices of the groups having the greatest spread of prices are given by classes. Six groups of commodities are given for England and the first three to fall, for example, belong to class 1, the remaining three to class 2. If several groups should fall at the same time so that it is impossible to tell to which class they belong, the fall is termed E, meaning either. The same method is employed in classifying the recovery of the prices of the different groups. Since eight groups of commodities are given for the United States and Germany, each class consists of four.

TABLE XLVII
England

Groups Having Greatest Spread of Prices	Fall by Classes	Recovery by Classes
<i>Crisis of 1857—</i>		
Vegetable food	1	2
Minerals	1	E
Sugar, tea, and coffee	E	E
<i>Crisis of 1866—</i>		
Textiles	1	2
Vegetable food	2	2
Minerals	1	1
<i>Crisis of 1873—</i>		
Minerals	E	E
Textiles	1	E
Sundry materials	1	E
<i>Crisis of 1883—</i>		
Sugar, tea, and coffee	E	1
Vegetable food	E	2
Sundry materials	E	2
<i>Crisis of 1890—</i>		
Sugar, tea, and coffee	E	2
Textiles	E	2
Minerals	2	1
<i>Average of Five Crises—</i>		
{ Vegetable food	1	2
{ Sugar, tea, and coffee	1	1
{ Textiles	1	2
{ Minerals	2	1
Sundry materials	2	2
Animal food	2	1

In the crisis of 1857 in England, prices of minerals fell early and rose late. This tendency is less pronounced in the later crises. In fact, in the crisis of 1890, minerals fell late and rose early. The average result for the five crises also gives a late fall and early rise. In the earlier period, promotion in minerals was extensive, but in the later years foreign competition was greater in textiles.¹ From the crisis of 1866 on, the textiles became prominent and on the average fell early and rose late.

TABLE XLVIII
United States

Groups Having Greatest Spread of Prices	Fall by Classes	Recovery by Classes
<i>Crisis of 1848—</i>		
Fuel and lighting	1	2
Clothing	1	1
Miscellaneous	2	2
Food	E	1
<i>Crisis of 1857—</i>		
Fuel and lighting	E	E
House furnishing goods	1	2
Metals and implements	1	2
Miscellaneous	E	E
<i>Crisis of 1873—</i>		
House furnishing goods	1	E
Food	1	E
Fuel and lighting	E	1
Clothing	E	E
<i>Crisis of 1884—</i>		
Drugs and chemicals	1	2
{ Fuel and lighting	2	1
{ Miscellaneous	2	2
Metals and implements	1	2
<i>Crisis of 1893—</i>		
Food	E	1
Metals and implements	2	2
Clothing	1	2
Lumber and building materials	1	2
<i>Average of Five Crises—</i>		
Fuel and lighting	2	1
House furnishing goods	2	2
Food	2	1
Miscellaneous	2	2
Clothing	1	1
Metals and implements	1	2
Drugs and chemicals	1	1
Lumber and building materials	1	2

¹It is very probable that metals will be found to have played a more important part than usual in England in the crisis of 1900.

In the United States fuel and lighting in the early crises showed a tendency to fall first and rise last—the sign of overproduction. In the later crises the reverse tendency is seen, due, probably, to a greater power of contracting business and adapting supply to demand. Clothing shows a uniform tendency in the direction of an early fall. In the earlier crises the recovery was also early, but later on recovery became slower, more like the movement of textile prices in England. Either the textile trade is more speculative than formerly, or the raw materials fluctuate more because of foreign markets and tariffs. It is well known that the tariff fight is especially about textiles. The prices of raw materials (see table XXII) have shown a greater spread in the later crises than in the crisis of 1857.

TABLE XLIX
Germany

Groups Having Greatest Spread of Prices	Fall by Classes	Recovery by Classes
<i>Crisis of 1857—</i>		
Tropical, etc.	E	2
Agricultural products	1	2
East India goods, etc.	E	1
Minerals and metals	E	2
<i>Crisis of 1866—</i>		
Divers	E	E
Textile materials	E	2
British exports	E	2
Minerals and metals	E	1
<i>Crisis of 1873—</i>		
Minerals and metals	1	E
Divers	1	E
Textile materials	1	2
British exports	1	2
<i>Crisis of 1883</i>		
Agricultural products	2	E
Divers	E	2
Textiles	E	E
Tropical, etc.	1	1
<i>Average of Four Crises—</i>		
Divers	1	1
{ Minerals and metals	1	1
{ Agricultural products	2	2
Textiles	1	2
Tropical, etc.	2	1
British exports	2	2
East India goods, etc.	1	1
Animal products	2	2

Minerals and metals in Germany occupy an intermediate place between the ones belonging to that group of commodities in England and the United States. There is least speculation in minerals in England, shown by a late fall and early rise. There is most speculation in this group of commodities in the United States, as evidenced by an early fall and a late rise. Now in Germany, minerals and metals fall early but they also rise early. This latter fact may be accounted for, not so much by lack of speculation, as by an early disposition in Germany to form cartels and restrict production. Indeed the Germans are the pathfinders in the matter of pools and combines.

Food prices in Germany in the crisis of 1857 agree with the action of food prices in England during that crisis: the fall is early and the rise late. England maintains this order in the later crises, but Germany shows a tendency to defer the fall of agricultural products. These show on the average a late fall and a late rise. The keeping up of food prices, notwithstanding the complaints of the agriculturists, is probably due to the fact that the tariffs of Germany are more effectual than is popularly supposed.

In the interpretation of these tables the inference has been drawn, as stated above, that the commodities which are hardest hit by crises are those which not only experience the heaviest fall in price, but those which in addition suffer the longest period of depression, i.e. fall first and rise last. The groups of commodities which meet these three conditions—a large spread of prices, an early fall, and a late rise—have been selected out for each country with very satisfactory results:

TABLE L
Groups of Commodities Most Affected by Crises

CRISIS	Commodities
<i>England—</i>	
1857.....	Vegetable food Minerals Sugar, tea, and coffee
1866.....	Textiles
1873.....	Minerals Textiles Sundry materials
1883.....	Vegetable food Sundry materials
1890.....	Sugar, tea, and coffee Textiles
<i>United States—</i>	
1848.....	Fuel and lighting
1857.....	Fuel and lighting House furnishing goods Metals and implements Miscellaneous
1873.....	House furnishing goods Food Clothing
1884.....	Drugs and chemicals Metals and implements
1893.....	Clothing Lumber and building materials
<i>Germany—</i>	
1857.....	Tropical, etc. Agricultural products Minerals and metals
1866.....	Divers Textiles
1873.....	British exports Minerals and metals Divers Textile materials
1883.....	British exports Divers Textiles

It will be noticed first of all that, as a rule, the more severe the crisis the greater the number of groups which are severely affected, the crises of 1857 and 1873 standing first in this regard. On the other hand, the crisis of 1848 in the United States and 1866 in England, both of which were comparatively mild, show but one group each.

The group common to the three countries in the crisis of 1857 is minerals and metals. This points to the rapid extension of railways which took place prior to this crisis, especially in the United States. In the latter country alone the number of miles of railway increased from 5,996 in 1848 to 28,789 in 1859.¹ The disturbance in food prices in England and Germany during this same crisis is doubtless connected with the changes in and rapid extension of crop areas. England, it will be remembered, had shortly before (1846-49) abolished the corn laws, and her wheat production was decreasing in importance. Her declining position as an agricultural nation is shown by the following figures giving the percentage of population engaged in the different occupations:²

OCCUPATION	1851	1861
Agriculture.....	20.9	18.0
Fishing.....	0.2	0.2
Mining.....	4.0	4.5
Building.....	5.5	5.8
Manufactures.....	32.7	33.0
Transportation.....	4.1	4.6

The textiles suffered in the crisis of 1866. This fact is adequately explained by the enormous check in cotton production in the United States owing to the Civil war, and the speculation in cotton which followed as a result.

The crisis of 1873 was a very general crisis as well as a very severe one. "The promotions for all the world for the year 1872 were estimated at 12.6 billions of francs, of which the largest part naturally went to France on account of the war loans. Outside of France, the largest investments were in America, England, Germany, Austria-Hungary, Turkey, Russia, and Italy, in the order mentioned. The two years 1871 and 1872 absorbed 20 billions of francs. In 1871, however, four-fifths of the investments were in state loans, while in 1872, in spite of the French

¹Ryner. *On the Crises of 1837, 1847, and 1857, in England, France, and the United States.* In Univ. Stud. (Univ. of Neb.), 5:156, April, 1905.

²*Ibid.*, 154.

government loans, the majority of the investments were in private industry, especially in railroads and manufacturing."¹ This harmonizes with the data for this crisis as given by the preceding tables, which show the disturbance to have been chiefly in textiles and minerals.

England experienced a "protectionist" crisis in 1883. Vegetable food is the chief sufferer. The lack of protection in England and the protection of food in other countries, conjoined with increasing American competition in agricultural production, wrought the ruin of English agriculture. The fall in the price of vegetable food is best shown by comparing its index number at different periods: in 1873 it stood at 106, in 1883 at 82, in 1893 at 59, and in 1903 at 62.²

The crisis of 1884 in the United States was, as is well known, a railroad crisis. Speculation centered, therefore, in metals and implements.

Textiles, in the crisis of 1890-93, suffered in all countries. So slow was their recovery after the crisis that all other lines of business were well under headway again toward boom conditions before the textile industries began to improve.³

In conclusion, table LI is given, showing which groups of commodities, according to the threefold test, on the average suffer most from crises. England and Germany agree in giving textiles a prominent place. The depression of English agriculture due to competition with new lands accounts for the sensitiveness of vegetable food. In this case, as heretofore, it seems best to consider the great changes in food prices as a *cause* rather than an *effect* of crises. The extremely rapid industrial development of the United States has caused speculation to center in those enterprises which make heavy demands upon metals and implements. The industries of the United States more than England work with raw materials; hence metals are more fundamental in this country and more influenced by general speculation. In the

¹Taylor. *Promotion before the Trusts*. In *Jour. of Pol. Econ.*, 12:386.

²See Appendix, table C.

³See the writer's article, *Speculation in Relation to the World's Prosperity 1897-1902*. In *Univ. Stud. (Univ. of Neb.)*, 6:88-89, January, 1906.

spread of prices, however, metals and implements in the United States fall in the second group, i.e. among those of the smaller spread. But by consulting tables XL and XLIII it will be seen that the price spread of metals and implements is, on the average, only slightly less than that of textiles which come within the first group.

TABLE LI

Groups of Commodities Which on the Average Are Most Affected by Crises

COUNTRY	Commodity
England	Vegetable food and textiles
United States	Metals and implements
Germany	Textiles

BOOKS AND ARTICLES CITED

- Bankers' Magazine*, London.
- Cannon, James G. *Clearing-Houses*. New York, 1900.
- Cleveland, Frederick A. *The Bank and the Treasury*. London, 1905.
- Commercial and Financial Chronicle*. Washington.
- England, Minnie T. *Speculation in Relation to the World's Prosperity, 1897-1902*. In Univ. Stud. (Univ. of Neb.), January, 1906.
- Giffen, Sir Robert. *Economic Inquiries and Studies*. vol. 1, London, 1904.
- History of Banking in All the Leading Nations* (compiled by thirteen authors). vols. 1-4, New York, 1896.
- Journal of the Royal Statistical Society*. London.
- Juglar, Clément. *Des crises commerciales et de retour périodique en France, en Angleterre et aux États-Unis*. Paris, 1889.
- Laughlin, J. Laurence. *Principles of Money*. New York, 1903.
- Palgrave, Robert H. I. *Bank Rate and the Money Market in England, France, Germany, Holland, and Belgium, 1844-1900*. London, 1903.
- Ryner, Ira. *On the Crises of 1837, 1847, and 1857, in England, France, and the United States*. In Univ. Stud. (Univ. of Neb.), April, 1905.
- Statistical Abstract for the United Kingdom. London.
- Taylor, W. G. Langworthy. *Promotion before the Trusts*. In Jour. of Pol. Econ., 12:382.
- *The Kinetic Theory of Economic Crises*. In Univ. Stud. (Univ. of Neb.), January, 1904.
- Tribune Almanac. New York.
- United States—Congress. Public documents, serial nos. 3074 (3 vols.), 4530, 4668.
- United States—Treasury Dept. *Annual Report of the Secretary of the Treasury on the State of the Finances*. Washington, 1886.
- World Almanac and Encyclopedia. New York.

APPENDIX

CONSTRUCTION OF TABLES

Tables in the Text	Compiled from Tables in the Appendix and Text.
I.....	V and C; W and A; I and D
II.....	F, H, and G
III.....	G
IV.....	P
V.....	F and A; H and E; I and D; G and C
VI.....	W and N; J and K
VII.....	O
VIII.....	M, N, G, and C; J, L, F, and I
IX.....	L and C; M and A
X.....	F, H, and G
XI.....	A and F; E and H; D and I; C and G
XII.....	M, N, C, and G; J, L, A, and F
XIII.....	XII
XIV.....	L
XV.....	Chart I
XVI.....	C, A, E, and D
XVII.....	A, C, D, and E
XVIII.....	Q, U, S, and R
XIX.....	T
XX.....	Q, U, S, and R
XXI.....	T
XXII.....	Q, U, S, and R
XXIII.....	T
XXIV.....	XXV, XXXII, and XXXIX
XXV.....	C
XXVI.....	A
XXVII.....	D
XXVIII.....	XXV
XXIX.....	XXVI
XXX.....	XXVII
XXXI.....	XXV, XXVI, and XXVII
XXXII.....	C
XXXIII.....	A
XXXIV.....	D
XXXV.....	XXXII
XXXVI.....	XXXIII
XXXVII.....	XXXIV
XXXVIII.....	XXXII, XXXIII, and XXXIV
XXXIX.....	C
XL.....	A
XLI.....	D
XLII.....	XXXIX
XLIII.....	XL
XLIV.....	XLI
XLV.....	XXXIX, XL, and XLI
XLVI.....	XXXI, XXXVIII, and XLV
XLVII.....	XXVIII, XXXV, and XLII
XLVIII.....	XXIX, XXXVI, and XLIII
XLIX.....	XXX, XXXVII, and XLIV
L.....	XLVII, XLVIII, and XLIX
LI.....	XLVII, XLVIII, and XLIX

In the appended tables the maximum points before crises are indicated by two stars; the minimum points by one. In determining the rise of prices, the increase of loans, etc., it was found that in rare instances the same low point was reached in two different years. The earlier one of the two was taken as the minimum point. Where the same high point was reached in different years, the later one was taken as the maximum.

TABLE A

The Aldrich report on the course of relative prices in the United States covers the years from 1840 to 1891 inclusive. This table may be found in U. S. Public Documents, no. 3074, vol. 3; 91; in the Monthly Summary of Commerce and Finance, June, 1904; 4698 (U. S. Public Documents, no. 4668); in Laughlin's *Principles of Money*, 215-16. The data for 1892 to 1903 are obtained from the Bureau of Labor report on the course of relative prices, by transposing the latter to the same basis as the figures of the Aldrich report (1860=100). To simplify the work of transposition, the first column of the Bureau of Labor report was omitted, leaving nine columns which correspond to the nine columns of the Aldrich report. To illustrate the method of transposition: according to the Bureau of Labor report, food prices in 1892 fell 10.4 per cent; therefore the Aldrich index number for food in 1891 was reduced 10.4 per cent, or from 106.9 to 95.8, and so on for all commodities.

YEAR	Food	Clothing	Fuel and Lighting	Metals and Imple-ments	Lumber and Building Materials	Drugs and Chemi-als	House Furnish-ing Goods	Miscel-laneous	All Articles
1840.....	96.6	110.7	395.8	123.5	110.0	145.8	116.4	147.1	116.8
1841.....	94.4	113.4	208.9	123.7	111.8	141.3	116.4	147.1	115.8
1842.....	82.9	100.9	202.0	118.7	108.8	131.6	116.4	170.6	107.8
1843.....	79.3*	99.9*	187.5	114.7	105.4	121.4	100.3*	123.5	101.5*
1844.....	81.6	105.0**	119.7*	133.3	103.0*	119.7*	102.3	129.5	101.9
1845.....	87.3	97.1	239.6**	110.8*	106.7	121.0	102.3	114.8	102.8
1846.....	94.6	95.3	143.8	116.9	106.2	123.9**	111.0	111.0*	106.4
1847.....	94.7**	97.6	110.7	120.6**	108.2**	112.5	120.3	121.7	106.5**
1848.....	83.5	87.5	106.1	119.7	105.3	113.0	121.7**	125.6**	101.4
1849.....	79.0*	82.2*	100.0	124.9	97.6	111.0	120.5	109.8	98.7*
1850.....	85.5	91.3	102.6	114.8*	102.2	123.6	125.6	107.7	102.3
1851.....	90.6	94.7	97.3	119.2	97.2*	125.8	120.0	102.7	105.9
1852.....	88.7	88.7	93.5*	117.7	100.4	111.8	111.9*	100.5*	102.7
1853.....	101.2	98.6	101.6	122.8	103.2	107.0*	118.7	109.2	109.1
1854.....	105.9	97.4	106.8	125.6**	114.1**	110.7	121.2	108.4	112.9
1855.....	111.8	94.7	121.1	117.8	103.4	129.2	121.2**	115.2	113.1
1856.....	110.4	100.6	126.4**	115.3	102.8	135.5**	115.5	121.6**	113.2**
1857.....	117.5**	106.0**	113.3	110.4	105.0	126.8	116.8	110.0	112.5

TABLE A—Continued

YEAR	Food	Clothing	Fuel and Lighting	Metals and Imple-ments	Lumber and Building Materials	Drugs and Chemi-cals	House Furnish-ing Goods	Miscel-laneous	All Articles
1858.....	94.6	98.0	111.4	101.3	103.8	116.0	108.7	97.1	101.8
1859.....	98.8	101.1	98.8	100.1	98.7	104.2	103.2	100.8	100.2
1860.....	100.0	100.0	100.0	100.0	100.0	100.0*	100.0	100.0	100.0*
1861.....	95.8	94.9*	103.5	102.5	108.9	101.3	96.8	100.7	100.6
1862.....	107.7	121.1	94.8	114.3	145.6	113.6	87.3	101.2	114.9
1863.....	91.7*	132.0	73.8*	96.5	122.1	101.0	84.8	89.0*	102.4
1864.....	106.6	167.7	115.9	115.6	142.3	109.5	105.9	99.3	122.5
1865.....	100.1	138.4	110.0	88.5*	84.2*	125.6	83.8*	93.8	100.3
1866.....	124.1	161.7	200.2	122.1	133.4	164.3	132.3	122.1	130.3
1867.....	121.8	133.7	145.8	119.8	132.8	156.9	118.2	119.9	127.9
1868.....	118.6	106.0	157.9	108.7	125.8	128.4	97.4	118.5	115.9
1869.....	120.1	108.8	152.5	104.2	122.3	118.7	89.0	119.7	113.2
1870.....	126.8	114.9	162.0	105.4	122.3	123.3	100.2	122.6	117.3
1871.....	152.9**	120.4	130.2	110.4	136.8	125.9	116.1**	134.4**	122.9
1872.....	122.2	131.1**	136.8**	117.3**	153.0**	122.8	112.9	121.6	127.2**
1873.....	115.2	121.5	119.4	115.2	152.5	125.6	96.8	117.5	122.0
1874.....	118.0	114.8	134.3	108.7	139.0	131.8**	98.3	116.5	119.4
1875.....	116.0	106.8	139.1	104.4	127.7	128.2	84.4	109.2	113.4
1876.....	109.1	95.3	128.2	96.1	121.7	108.0*	77.3	101.2*	104.8
1877.....	113.3	95.9	101.7	94.2	118.5	115.2**	74.4	111.3	104.4
1878.....	105.5	91.9	91.7*	90.8	115.2	112.6	73.3	110.2	99.9
1879.....	97.6*	91.1*	95.3	88.4*	115.1*	110.9	68.6*	102.1	96.6*
1880.....	107.6	104.5**	100.2	96.3**	130.9	113.1	85.2**	109.8	106.9
1881.....	110.9	99.9	113.7	91.1	131.3	110.4	77.6	108.8	105.7
1882.....	118.8	98.7	110.1	137.5**	107.6	107.6	78.1	114.6	108.5**
1883.....	118.8**	94.8	114.2**	87.5	134.3	98.1	77.5	117.3**	106.0
1884.....	108.9	88.9	102.4	81.0	129.5	95.7	76.3	111.9	99.4

1885.....	98.7*	84.8*	89.6	77.4	126.6*	86.9	70.1	97.5	93.0
1886.....	99.5	85.1**	86.2*	75.8	128.5**	83.9	68.4	91.3	91.9*
1887.....	104.2	84.7	88.6	74.9	126.5	83.6*	66.4*	88.6*	92.6
1888.....	109.4	84.7	94.9	74.9	124.8	86.0	66.9	89.3	94.2
1889.....	111.9**	83.6	95.3**	72.9*	124.0	88.8**	70.0	88.8	94.2**
1890.....	104.6	82.4	92.5	73.2	123.7	87.9	69.5	89.7	92.3
1891.....	106.9	81.1	91.0	74.9**	122.3	86.3	70.1**	95.1**	92.2
1892.....	95.8	79.4	85.4	71.1	116.1	85.7	67.8	92.3	87.6
1893.....	101.8	78.1	84.5	67.6	116.0	83.7	66.8	90.0	87.2
1894.....	92.3	70.1	78.1*	60.9	109.6	74.8	63.7	84.8	79.4
1895.....	87.5	67.7	82.9	61.7	107.1	73.2*	61.4	80.3	77.4
1896.....	77.5*	66.7	88.1	62.8	106.4	77.1	59.8	77.7*	74.8
1897.....	81.0	66.6*	81.5	58.0	103.0*	78.6	57.1*	78.2	74.2*
1898.....	87.4	68.2	80.6	57.9*	109.2	88.7	58.5	78.3	77.2
1899.....	90.8	70.6	88.7	86.8	120.5	92.6	60.5	82.7	84.0
1900.....	100.2	77.9**	100.6	91.2**	131.7	96.3**	70.4	92.9	91.2
1901.....	101.8	73.7	99.5	84.7	132.9	95.9	73.6	90.9	89.6
1902.....	107.0**	74.4	111.8	88.7	135.3	95.2	74.5	97.3**	93.2
1903.....	103.1	77.7	124.3**	89.0	138.3**	93.9	75.0**	96.9	93.8**

TABLE B
Bureau of Labor Report on the Course of Relative Prices
 (Average price for 1890-1903=100)
 Given in the Monthly Summary of Commerce and Finance, June, 1904: 4699 (U. S. Public Documents, no. 4668)

YEAR	Food	Cloths and Clothing	Fuel and Lighting	Metals and Imple-ments	Lumber and Building Materials	Drugs and Chemicals	House Furnish- ing Goods	Miscel- laneous	All Articles
1890.....	112.4	113.5	104.7	119.2	111.8	110.2	111.1	110.3	112.9
1891.....	115.7	111.3	102.7	111.7	108.4	103.6	110.2	109.4	111.7
1892.....	103.6	109.0	101.1	106.0	102.8	102.9	106.5	106.2	106.1
1893.....	110.2	107.2	100.0	100.7	101.9	100.5	104.9	105.9	105.6
1894.....	99.8	96.1	92.4	90.7	96.3	89.8	100.1	99.8	96.1
1895.....	94.6	92.7	98.1	92.0	94.1	87.9	96.5	94.5	93.6
1896.....	83.8	91.3	104.3	93.7	93.4	92.6	94.0	91.4	90.4
1897.....	87.7	91.1	96.4	86.6	90.4	94.4	89.8	92.1	89.7
1898.....	94.4	93.4	95.4	86.4	95.8	106.6	92.0	92.4	93.4
1899.....	98.3	96.7	105.0	114.7	105.8	111.3	95.1	97.7	101.7
1900.....	104.2	106.8	120.9	120.5	115.7	115.7	106.1	109.8	110.5
1901.....	105.9	101.0	119.5	111.9	116.7	115.2	110.9	107.4	108.5
1902.....	111.3	102.0	134.3	117.2	118.8	114.2	112.2	114.1	112.9
1903.....	107.1	106.6	149.3	117.6	121.4	112.6	113.0	113.6	113.6

TABLE C

Sauerbeck's relative prices in England are found (1846-1891) in U. S. Public Documents, no. 3074, vol. 1: 247; (1878-1903) in U. S. Public Documents, no. 4668: 4679.

(Average 1867 to 1877=100)

YEAR	Vegetable Food	Animal Food	Sugar Coffee and Tea	Total Food	Minerals	Textiles	Sundry Materials	Total Materials	Grand Total
1846.....	106	81	98	95	92	77	86	85	89
1847.....	129	88	87	105	94	78	86	86	95**
1848.....	92	83	69*	84	78	64*	77	73*	78
1849.....	79	71	77	76	77	67	75*	73	74*
1850.....	74	67*	87	75	77	78	80	78	77
1851.....	73*	68	84	74*	75*	75	79	76	75
1852.....	80	69	75	75	80	78	84	81	78
1853.....	100	82	87	91	105	87	101	97	95
1854.....	120	87	85	101	115**	88	109	104	102
1855.....	120**	87	89	101	109	84	109	101	101
1856.....	109	88	97	99	110	89	109	102	101
1857.....	105	89**	119**	102**	108	92**	119**	107**	105**
1858.....	87	83*	97	88*	96	84*	102	94*	91*
1859.....	85	85	102	89	98	88	107	98	94
1860.....	99	91	107	98	97	90	111	100	99
1861.....	102	91	96*	97	91*	92	109	99	98
1862.....	98	86	98	94	91	123	106	107	101
1863.....	87	85	99	89	93	149	101	115	103
1864.....	79*	89	106**	88	96**	162**	98	119**	105**
1865.....	84	97**	97	91	91	134	97*	108	101
1866.....	95	96	94*	95	91	130	99	107	102

TABLE C—Continued

YEAR	Vegetable Food	Animal Food	Sugar Coffee and Tea	Total Food	Minerals	Textiles	Sundry Materials	Total Materials	Grand Total
1867	115**	89	94	101**	87	110	100	100	100
1868	113	88*	96	100	85*	106	102**	99*	99
1869	91	96	98	94	89	109	100	100	98
1870	88*	98	95	93*	89	106	99*	99	96*
1871	94	100	100	98	93	103*	105	101	100
1872	101	101	104	102	127	114**	108**	115**	109
1873	106**	109**	106**	107**	141**	103	106	114	111**
1874	105	103	105	104	116	42	96	100	102
1875	93	108	100	100	101	88	92	93	96
1876	92	108	98	99	90	85	95	91	95
1877	100	101	103	101	84	85	94	89	94
1878	95	101	90	96	74	78	88	81	87
1879	87*	94*	87*	90*	73*	74*	85*	78*	83*
1880	89**	101	88**	94**	79	81**	89**	84**	89**
1881	84	101	84	91	77	77	86	80	85
1882	84	104**	76	89	79**	73	85	80	84
1883	82	103	77	89	76	70	84	77	82
1884	71	97	63	79	68	68	81	73	76
1885	68	88	63	74	66*	65	76	70	72
1886	65	87	60*	72	67	63*	69	67*	69
1887	64*	79*	67	70*	69	65	67*	67	68*
1888	67**	82	65	72	78	64	67	69	70
1889	65	86**	75**	75**	75	70**	68	70	72
1890	65	82	70	73	80**	66	69	71**	72

1891.....	75	81	71	77	76	59	69**	68	72**
1892.....	65	84	69	73	71	57	67	65	68
1893.....	59	85	75	72	68	59	68	65	68
1894.....	55	80	65	66	64	53	64	60	63
1895.....	54	78	62	64	62*	52	65	60	62
1896.....	53*	73*	59	62*	63	54	63	60	61*
1897.....	60	79	52	65	66	51*	62*	59*	62
1898.....	67**	77	51*	68	70	51	63	61	64
1899.....	60	79	53	65	92	58	65	70	68
1900.....	62	85	54**	69**	108**	66**	71	80**	75**
1901.....	62	85	46	67	89	60	71	72	70
1902.....	63	87**	41	67	82	61	71**	71	69
1903.....	62	84	41	66	82	66	69	72	69

TABLE D
 Soetheer's Relative Prices in Hamburg (1851-1891) are found in U. S. Public Documents, no. 3074, vol. 1: 295;
 and in Laughlin's *Principles of Money*, 203.
 (1860=100)

YEAR	Agricultural Products	Animal Products	Tropical, etc.	East India Goods, etc.	Minerals and Metals	Textile Materials	Divers	British Exports	Total Articles (114)
1851.....	74.0	82.5	74.8	83.1	88.1	96.0	89.0	92.8	82.8
1852.....	82.8	79.8	79.2	83.1	88.1	96.6	81.4	90.9	84.1
1853.....	95.8	85.9	103.7	95.8	100.5	93.3	90.0	95.3	94.0
1854.....	112.5	90.6	93.8	98.2	106.7	102.7	102.2**	94.3	100.2
1855.....	118.7**	92.4	118.0	100.6	109.6	95.3	93.8	93.1	102.7
1856.....	111.4	95.4	129.6	103.1	107.4	92.0	86.0	93.3	101.9
1857.....	103.3	104.8**	140.7**	116.7**	114.7**	103.2**	92.5	95.9**	107.5**
1858.....	89.7	95.0	100.3	93.7*	100.3	95.3*	85.3*	95.6*	93.8*
1859.....	89.3	97.7	94.2	96.2	99.9	96.3	98.9	100.2	96.2
1860.....	100.0	100.0	100.0	100.0	100.0	100.0	100.0	100.0	100.0
1861.....	98.3	93.3	101.4	97.4	94.2	101.9	102.4	100.2	97.6
1862.....	94.8	95.1*	94.7	97.5	93.8*	114.3	134.4	108.2	101.4
1863.....	89.8	92.8*	95.5	97.2	94.7	139.6	138.1	126.4	103.7
1864.....	88.1*	96.6	90.9*	104.5**	96.2**	141.9**	139.2**	138.8**	106.9**
1865.....	94.6	101.1	94.7	96.5	91.0	108.3	103.6	130.5	101.4
1866.....	102.9	101.4**	104.9	98.0	88.8	124.1	95.3	132.9	104.0
1867.....	109.4**	99.2*	105.1**	95.1*	85.8	119.8	92.6	126.8	102.9
1868.....	105.9	99.8	100.3	97.1	84.4*	117.0	86.7	120.8	100.8*
1869.....	99.0	107.1	96.0*	101.5	88.7	120.0	84.0*	121.4	102.0
1870.....	98.1*	104.2	98.5	100.2	91.7	113.0	95.2	116.2	101.6
1871.....	108.2	107.8	102.2	100.0	93.7	109.6*	100.6	116.1*	105.0
1872.....	107.8	116.5	104.2	108.3	111.9	112.9**	110.0**	123.2**	112.1
1873.....	109.3	117.2	109.8	111.7	129.4**	110.0	102.0	121.7	114.3**

1874	112.9**	118.0	120.5**	113.7**	107.4	103.7	96.0	119.4	112.6
1875	103.3	118.6**	109.1	109.8	98.9	102.5	84.5	118.3	107.3
1876	105.5	116.5	106.9*	107.9*	97.8	97.1	87.1	112.9	106.1
1877	108.7	114.0	116.8	108.3**	91.0	99.6	85.4	108.0	105.6
1878	99.1*	105.8	111.6	104.4	86.6	94.1	83.2	105.1	99.7
1879	99.4	102.9*	115.6	102.5	77.6*	90.8	77.2*	100.3	96.8*
1880	103.3	110.1	128.5**	102.2	81.3**	88.9*	81.5	102.4	100.8
1881	102.8	113.1	121.8	101.9	78.1	91.3	81.2	97.6*	100.1
1882	103.5	116.0	115.7	101.8	80.1	97.5**	84.8**	99.2	101.0
1883	107.2**	116.9**	118.3	99.9	76.3	88.2	81.6	99.2**	101.0**
1884	92.6	112.3	99.8*	98.0	72.4	89.2	72.6	97.9	94.4
1885	82.8	105.0	102.8	96.8	68.3	88.2	69.6	95.2	89.9
1886	75.7	99.8	101.7	96.0*	64.9*	82.5	67.4	91.9	86.0
1887	72.0*	97.1	101.2	96.9	60.7	74.9*	66.2	90.9	84.3*
1888	73.4	96.4*	99.8	96.8	69.5	75.6	63.6*	89.9*	84.3
1889	76.3	97.9	106.0	98.8	72.3	81.9**	74.0	91.5**	87.7
1890	80.4	97.1	115.2	99.2**	76.9	75.3	78.5**	89.9	89.4
1891	89.6**	98.4**	116.3**	94.4	78.0**	73.9	72.8	90.1	90.3**

TABLE E

The statistics for French prices are found in Laughlin's *Principles of Money*, 208-9. The first column is DeFoville's export prices, the second is Palgrave's.

YEAR	(1)	(2)	YEAR	(1)	(2)
1827	96	1865	97	106
1847	78*	1866	91	108
			1867	87	97
1848	80	1868	83	96
1849	87	1869	82	93
1850	91	1870	81*	91
1851	90	1871	81	102
1852	98	1872	83**	105
1853	109	1873	80	105
1854	108			
1855	104	1874	76	97
1856	111**	1875	73	95
1857	110	1876	73	95
			1877	72	96
1858	102	1878	68*	91
1859	109	1879	70	87*
1860	105	1880	71	88**
1861	99*	1881	86
1862	100	1882	84
1863	100			
1864	101**	1883	80

TABLE F

The banking statistics of the United States for 1830-62 are given in the *History of Banking in All Nations*, 1: 456. From 1865 to 1903 the statistics are for the national banks, as given in U. S. Public Documents, no. 4658: 153-5. The amounts are in millions of dollars.

JANUARY	Circulation	Deposits	Total Circulation and Deposits	Loans
1830	51	58	272
1831	57	62	285
1832	62	67	301
1833	68	71	316
1834	94	75	324
1835	103	83	365
1836	140	115	457
1837	149**	127**	525**
1838	116	84	485
1839	135	90	492
1840	107	75	462
1841	107	64	386
1842	83	62	323
1843	58*	56*	254*
1844	75	84	264
1845	89	88	288
1846	105	96	312
1847	105	91	310
1848	128**	103**	344**
1849	114*	91*	332*
1850	131	109	364
1851	155	128	413
1852	156	189	527
1853	146	145	408
1854	204	188	557
1855	187	190	576
1856	195	212	634
1857	214**	230**	684**
1858	155*	185*	583*
1859	193	259	657
1860	207	253	691
1861	202	257	696
1862	183	297	647
1863	238	393

Minnie Throop England

TABLE F—Continued

National Banks

About Oct. 1	Circulation	Deposits	Total Circulation and Deposits	Loans
1865	171	549	720	487
1866	290	598	888	603
1867	297	568	865	609
1868	298	603	901	657
1869	296	523	819	682
1870	293	512	805	715
1871	317	631	948	831
1872	335	628	963	877
1873	340**	640	980	944
1874	334	683**	1,017**	954
1875	319	679	998	984**
1876	292	666	958	931
1877	291*	630*	921*	891
1878	301	668	969	834*
1879	313	736	1,049	878
1880	317	887	1,204	1,041
1881	320**	1,083	1,403	1,173
1882	315	1,134**	1,449**	1,243
1883	310	1,063	1,373	1,309**
1884	289	993*	1,282*	1,245*
1885	269	1,116	1,385	1,306
1886	228	1,189	1,417	1,451
1887	167	1,274	1,441	1,587
1888	151	1,406	1,557	1,684
1889	128	1,522	1,650	1,817
1890	123*	1,594	1,727	1,986
1891	131	1,608	1,739	2,005
1892	143	1,779**	1,922**	2,171**
1893	183**	1,465*	1,648*	1,843*
1894	172*	1,742	1,914	2,007
1895	182	1,715	1,897	2,059
1896	209	1,613	1,822	1,893
1897	198	1,869	2,067	2,066
1898	194	2,106	2,300	2,172
1899	200	2,529	2,729	2,516
1900	283	2,602	2,885	2,709
1901	323	3,044	3,367	3,051
1902	318	3,333**	3,651	3,314
1903	375**	3,305	3,680**	3,508**

TABLE G

The statistics (annual averages) for the Bank of England (1844-1900) are found in Palgrave's *Bank Rate and the Money Market*, 12-15. Loans and advances as here given are the sum of columns 30 and 33. The amounts are in millions of pounds sterling.

YEARS	Private Deposits	Note Circulation	Total Circulation and Deposits	Loans and Advances	Other Securities
1844.....	8.0	20.2	28.2	4.0	9.4
1845.....	9.6	20.6**	30.2	6.4	12.2
1846.....	13.0**	20.2	33.2**	10.8	16.6
1847.....	8.6*	19.1	27.7*	11.4**	17.2**
1848.....	9.8	18.0*	27.8	5.7	11.9
1849.....	10.0	18.4	28.4	3.5*	10.2*
1850.....	9.8	19.4	29.2	4.5	11.0
1851.....	9.3	19.4	28.7	4.6	12.6
1852.....	12.8	21.9	34.7	3.6	11.3
1853.....	13.4**	22.6**	36.0**	7.0	15.0
1854.....	11.0	20.6	31.6	6.7	14.7
1855.....	11.7	19.8	31.5	6.6	15.3
1856.....	11.1	19.6	31.7	8.5	17.0
1857.....	10.6*	19.4*	30.0*	11.3**	20.3**
1858.....	14.1	20.2	34.3	5.2*	16.3*
1859.....	14.3	21.3	35.6	6.5	18.1
1860.....	13.5	21.2	34.7	9.4	20.5
1861.....	12.5	19.9	32.4	7.5	18.7
1862.....	14.6	20.8	35.4	7.7	18.9
1863.....	13.9	20.6	34.5	9.6	20.1
1864.....	13.1	20.6	33.7	10.5	20.2
1865.....	14.0	21.1	35.1	11.0	20.5
1866.....	16.7	23.1	39.8	13.1**	22.9**
1867.....	18.7	23.4	42.1	7.6	18.2
1868.....	20.1**	23.9**	44.0**	6.8*	17.6
1869.....	18.0*	23.4	41.4*	7.6	16.8*
1870.....	18.1	23.3*	41.4	10.1	18.6
1871.....	21.3**	24.4	45.7**	9.2	18.8
1872.....	19.9	25.5	45.4	10.8**	21.4
1873.....	19.0	25.6	44.6*	10.6	21.6**
1874.....	18.8*	26.2	45.0	7.4	18.4
1875.....	21.1	27.3	48.4	7.7	19.1
1876.....	23.4	27.7	51.1	17.5*
1877.....	22.5	27.8	50.3	18.8
1878.....	23.2	28.0	51.2	20.4
1879.....	30.6**	29.2**	59.8**	20.8
1880.....	26.1	26.9	53.0	19.1
1881.....	25.2	26.3	51.5	22.1
1882.....	23.6*	25.9	49.5	22.9**
1883.....	23.6	25.5	49.1	22.1

TABLE G—*Continued*

YEARS	Private Deposits	Note Circulation	Total Circulation and Deposits	Loans and Advances	Other Securities
1884.....	23.9	25.3	49.2	22.5
1885.....	26.6	24.6	51.2	21.1
1886.....	24.0	24.6	48.6	20.7
1887.....	24.0	24.3	48.3*	19.5*
1888.....	24.5	24.2*	48.7	19.9
1889.....	25.3	24.3	49.6	21.5
1890.....	27.5	24.5	51.0	23.4
1891.....	31.4**	25.1	56.5**	29.6**
1892.....	30.2*	25.8	56.0*	26.2
1893.....	30.3	25.8**	56.1	25.5
1894.....	33.6	25.2*	58.8	21.3*
1895.....	40.5	25.8	66.3	22.1
1896.....	49.3**	26.4	75.7**	29.2
1897.....	39.8	27.1	66.9	29.4
1898.....	39.2	27.4	66.6	31.8
1899.....	39.5	27.8	67.3	32.7**
1900.....	40.6	29.3**	69.9	29.4

TABLE H

The data for the items (1800-1887) of the Bank of France are found in Juglar's *Crises Commerciales*, 400. In each case the annual maximum figures are given. The amounts are in millions of francs.

YEAR	Circulation	Deposits	Total Circulation and Deposits	Discounts
1800	22	6	28	24
1801	25	9	34	45
1802	45	16	61	83
1803	57	21	78	88
1804	69	22**	91	119
1805	79**	18*	97	121**
1806	74*	37	111	80*
1807	107	51	158	104
1808	108	60	168	142
1809	104	31	135	144
1810	117	59	176	187
1811	120	59**	179**	189**
1812	133**	43	176	128
1813	94	24*	118*	142
1814	65*	55	120	90
1815	71	50	121	74*
1816	79	55	134	79
1817	101	40	141	101
1818	126	88**	214**	145**
1819	135	60*	195*	119
1820	171	77	248	67*
1821	195	80	275	81
1822	216	88	304	101
1823	212	111	323	151
1824	251**	94	345	186**
1825	243	117**	360**	154
1826	198*	70	268*	177
1827	204	64	268	127
1828	214	70	284	116*
1829	214	60*	274	119
1830	238	87	325	196**
1831	238	106**	344**	172
1832	258**	84	342	68
1833	228	69	297	65*
1834	222	61*	283	88
1835	241	72	313	98
1836	216*	63	279*	149
1837	220	90	310	157
1838	230	93**	323	176
1839	237	68	305	228**

TABLE H—Continued

YEAR	Circulation	Deposits	Total Circulation and Deposits	Discounts
1840	255**	90	345**	211
1841	252*	63	315	190
1842	253	47*	300*	192
1843	255	48	303	194
1844	277	59	336	170*
1845	296	119	415	264
1846	309**	119**	428**	285
1847	298	69*	367*	320**
1848	432*	113	545	302
1849	448	139	587	168
1850	515	127	642	145*
1851	583	155	748	154
1852	687	218**	905	282
1853	704**	205	909**	401
1854	669	212	881	433
1855	684	198	882	530
1856	666	202	868	575
1857	646*	168*	814*	628**
1858	732	205	937	548*
1859	772	341**	1,113	572
1860	805	255	1,060	582
1861	802	206	1,008	633
1862	869**	323	1,192**	682
1863	864	215	1,079	681
1864	839*	181*	1,020*	791**
1865	924	221	1,145	698
1866	1,029	422	1,451	781
1867	1,195	430	1,625	775
1868	1,326	539	1,865	580*
1869	1,439	599	2,038	697
1870	1,814	625	2,439	1,380
1871	2,353	735	3,088	1,945
1872	2,678	752**	3,430**	2,552
1873	3,071**	271*	3,342	2,578**
1874	2,916	294	3,210	2,430
1875	2,702	580	3,282	1,667
1876	2,617	523	3,140	1,239
1877	2,725	695	3,420	920
1878	2,547	514	3,061	1,050
1879	2,328*	536	2,864*	861*
1880	2,481	482	2,963	1,011
1881	2,825	765	3,590	1,524
1882	2,953	1,004**	3,957**	1,724**
1883	3,097	580	3,677	1,248
1884	3,162**	476	3,638	1,351
1885	3,063	507	3,570	1,116
1886	2,973	1,461	4,434	1,125
1887	2,929	556	3,485	792

TABLE I

The data for the annual transactions of the Reichsbank is found in the *History of Banking in All Nations*, 4: 48-49. The sums are given in millions of marks.

YEAR	Loan on Securities	Transactions of Clearing Houses Connected with the Imperial Bank
1876	467.21
1877	492.83
1878	525.75
1879	628.40
1880	839.70
1881	1,046.57**
1882	900.87
1883	704.20*
1884	765.20	12,130.19*
1885	740.00	12,544.44
1886	775.84	13,350.48
1887	690.34	14,207.19
1888	709.58	15,514.56
1889	1,045.46	18,048.96**
1890	1,315.18**	17,091.30
1891	1,208.14	17,663.27
1892	907.01	16,762.79*
1893	1,054.39	18,272.93
1894	825.03*	18,398.04

Minnie Throop England

TABLE J

The average quotations of sixty active railway stocks on the New York stock exchange are given by the *Tribune Almanac*, 1903-4: 374. (Compiled from daily averages by *Dun's Review*.)

YEAR	Maximum	Minimum	YEAR	Maximum	Minimum
.....	1885	63.47	43.45
.....	1886	71.99	55.28
.....	1887	72.35	59.03
.....	1888	65.09	55.71
.....	1889	66.29	59.55
.....	1890	69.93	53.61
1872	76.57	57.57	1891	66.78	55.29
1873	69.61	40.83	1892	68.49	62.32
.....	1893	66.31	41.71
1874	58.79	41.79
1875	53.50	36.14	1894	52.49	47.37
1876	47.28	27.58	1895	56.07	44.49
1877	36.33*	20.58*	1896	50.76*	40.71*
1878	37.77	25.51	1897	59.99	45.64
1879	67.86	33.85	1898	67.04	52.55
1880	87.04	51.74	1899	76.29	66.72
1881	101.54**	69.93**	1900	84.87	68.49
1882	94.85	63.77	1901	103.98	84.36
1883	79.86	57.58	1902	116.27**	101.03**
1884	66.28	38.68	1903	109.10	82.62

TABLE K

The following average stock prices were given in the *Brooklyn Daily Eagle*, December 31, 1905: 4.

YEAR	TWENTY RAILWAY STOCKS		TWELVE INDUSTRIAL SHARES	
	Highest	Lowest	Highest	Lowest
1896	56.68*	41.82*	44.90*	28.48*
1897	67.28	48.12	55.82	38.49
1898	70.16	56.08	60.97	42.00
1899	87.04	72.48	77.61	58.27
1900	88.88	72.99	69.07	53.68
1901	117.86	103.37	78.26**	61.61**
1902	129.36**	113.08**	68.44	59.57
1903	121.28	88.80	67.70	42.15
1904	119.46	91.31	73.23	46.41
1905	133.80	114.52	96.74	68.76

TABLE L

The *Commercial and Financial Chronicle* (2d issue in January) gives the following data on the sales of shares and their average prices at the New York stock exchange.

YEAR	Sales of Shares	Average Price	YEAR	Sales of Shares	Average Price
1882	116,307,271	66.1	1894.....	49,075,032	64.2
1883	97,049,909	64.5	1895.....	66,583,232	60.3
1884	96,154,971	61.7*	1896.....	54,654,096	65.2
			1897.....	77,324,172	67.0
1885	92,538,947	64.1	1898.....	112,699,957	72.7
1886	100,802,050	65.6	1899.....	176,121,135	78.6
1887	84,914,616	61.1	1900.....	138,380,184	69.2
1888	65,179,106	62.5	1901.....	265,944,659	79.0
1889	72,014,600	61.0	1902.....	188,503,403	79.9**
1890	71,282,885	60.2	1903.....	161,102,101	73.2
1891	69,031,689	57.1			
1892	85,875,092	63.5**	1904.....	187,312,065	69.9
1893	80,977,839	60.3*

TABLE M

The prices of ten railway shares were computed from the quotations given by the *Journal of the Royal Statistical Society of London*, vols. 14-35. The stocks chosen were the Caledonian, Eastern Counties, Great Northern, London and North-Western, Midland, North Staffordshire, South-Eastern, York Newcastle and Berwick, and York and North Midland. Due notice was taken of change in name, etc. The sums are given in pounds sterling.

1st of January	Total Prices of 10 Railway Shares	1st of January	Total Prices of 10 Railway Shares	1st of January	Total Prices of 10 Railway Shares
.....	1858	827.5	1867	883.6
1850	304.7	1859	846.7	1868	763.5*
1851	355.2	1860	858.2	1869	814.0
1852	356.0	1861	919.0	1870	884.2
1853	695.2**	1862	880.5	1871	944.5
1854	572.2	1863	915.5	1872	1,232.5
1855	616.2	1864	965.2
1856	572.8*	1865	1,024.0**
1857	702.0	1866	944.5

TABLE N

The market value of securities at the Stock Exchange of London is given by the *Banker's Magazine*, London. The closing figures of the year are taken. The values are expressed in thousands of pounds.

YEAR	Market Value of Securities	YEAR	Market Value of Securities	YEAR	Market Value of Securities
.....	1891.....	2,820	1901.....	3,063
.....	1892.....	2,819	1902.....	3,083
.....	1893.....	2,752*	1903.....	2,994
1884.....	2,667*	1894.....	2,881
1885.....	2,695	1895.....	2,951
1886.....	2,748	1896.....	3,198
1887.....	2,772	1897.....	3,275**
1888.....	2,800	1898.....	3,241
1889.....	2,873**	1899.....	3,121
1890.....	2,835	1900.....	3,101

TABLE O

The total capital created and issued "in England" and "in England and elsewhere" for each year, is given for 1870-1888 by Juglar in *Les crises commerciales*, 512. The issues for the remaining years are found in the *Journal of the Royal Statistical Society*. The sums are given in millions of pounds

YEAR	Issues of Securities	YEAR	Issues of Securities
.....	1884.....	109.0
.....	1885.....	77.9*
.....	1886.....	101.8
.....	1887.....	111.2
.....	1888.....	160.2
1867.....	43.1*	1889.....	207.0**
1868.....	74.0	1890.....	142.5
1869.....
1870.....	92.2	1891.....	104.5
1871.....	209.7	1892.....	81.1
1872.....	271.0**	1893.....	49.1
1873.....	154.6	1894.....	91.8
.....	1895.....	104.6
1874.....	114.1	1896.....	152.6
1875.....	62.6	1897.....	157.2
1876.....	43.1*	1898.....	150.1
1877.....	51.5	1899.....	133.1
1878.....	59.2	1900.....	165.4**
1879.....	56.4
1880.....	122.2	1901.....	159.3
1881.....	189.4**	1902.....	153.8
1882.....	145.5	1903.....	108.4
1883.....	81.1

TABLE P

The per cent of the balances of the New York clearing house paid in money is found in the *Report of the Secretary of Treasury* (U. S.) in 1886, 1:525.

YEAR	Per cent	YEAR	Per cent
1854.....	5.2	1874.....	5.7
1855.....	5.4	1875.....	5.6
1856.....	4.8	1876.....	5.9
1857.....	4.4	1877.....	5.9
		1878.....	5.8
1858.....	6.6	1879.....	5.6
1859.....	5.6	1880.....	4.1
1860.....	5.3	1881.....	3.5
1861.....	6.0	1882.....	3.4
1862.....	6.0	1883.....	3.9
1863.....	4.6	1884.....	4.5
1864.....	3.7		
1865.....	4.0	1885.....	5.1
1866.....	3.7	1886.....	4.5
1867.....	4.0
1868.....	4.0
1869.....	3.0
1870.....	3.7
1871.....	4.1
1872.....	4.2
1873.....	4.1

TABLE Q

The following average prices in the New York market are found in U. S. Public Documents, no. 4530: 460.

YEAR	(1) Standard Sheetings per yard	(2) Standard Drillings per yard	(3) N. Y. Mills Bleached Shirtings per yard	(4) Standard Prints per yard	(5) 64 x 64 Printing Cloths per yard	(6) Middling Cotton per pound
	Cents	Cents	Cents	Cents	Cents	Cents
1855.....	7.64	7.77	15.00	9.80	5.11	10.39
1856.....	7.50	8.10	15.00	9.50	5.36	10.30
1857.....	8.90**	9.04**	15.00	10.10**	5.98**	13.51**
1858.....	8.25*	8.70*	15.00	9.50*	5.60	12.23
1859.....	8.50	8.82	15.42	9.50	5.67	12.08
1860.....	8.73	8.92	15.50	9.50	5.44	11.00*
1861.....	10.00	9.58	15.33	9.71	5.33*	13.01
1862.....	18.55	18.94	21.00	14.40	9.81	31.29
1863.....	36.04	33.41	35.33	21.24	15.20	67.21
1864.....	52.07	53.02	48.35	33.25	23.42	101.50
1865.....	38.04	37.33	49.58	29.00	20.24	83.38
1866.....	24.31	25.14	45.90	21.15	14.13	43.20
1867.....	18.28	18.79	35.21	16.58	9.12	31.59
1868.....	16.79	16.49	26.65	13.83	8.18	24.85
1869.....	16.19	16.49	24.79	14.00	8.30	29.01
1870.....	14.58	14.98	22.50	12.41	7.14	23.98
1871.....	13.00	13.64	20.83	11.62	7.41	16.95
1872.....	14.27**	15.14**	20.66	12.00**	7.88**	22.19**
1873.....	13.31	14.13	19.41	11.37	6.69	20.14
1874.....	11.42	11.75	18.04	9.75	5.57	17.95
1875.....	10.41	11.12	15.12	8.71	5.33	15.46
1876.....	8.85	8.71	13.58	7.06	4.10	12.98
1877.....	8.46	8.46	12.46	6.77	4.38	11.82
1878.....	7.80*	7.65	11.00*	6.09*	3.44*	11.22
1879.....	7.97	7.57*	11.62	6.25	3.93	10.84*
1880.....	8.51	8.51**	12.74	7.41**	4.51**	11.51
1881.....	8.51**	8.06	12.74	7.00	3.95	12.03**
1882.....	8.45	8.25	12.95**	6.50	3.76	11.56
1883.....	8.32	7.11	12.93	6.00*	3.60	11.88
1884.....	7.28	6.86	10.46	6.00	3.36	10.88
1885.....	6.75*	6.36	10.37*	6.00	3.12*	10.45
1886.....	6.75	6.25*	10.65	6.00	3.31	9.28*
1887.....	7.15	6.58	10.88	6.00	3.33	10.21
1888.....	7.25**	6.75	10.94**	6.50	3.81	10.03
1889.....	7.00	6.75	10.50	6.50**	3.81**	10.65
1890.....	7.00	6.75**	10.90	6.00	3.34	11.07**
1891.....	6.83	6.41	10.64	6.00	2.95	8.60
1892.....	6.50	5.60	10.25	6.25	3.39	7.71
1893.....	5.90	5.72	9.75	5.25	3.30	8.56

TABLE Q—Continued

YEAR	(1) Standard Sheetings per yard	(2) Standard Drillings per yard	(3) N.Y. Mills Bleached Shirtings per yard	(4) Standard Prints per yard	(5) 64 x 64 Printing Cloths per yard	(6) Middling Cotton per pound
	Cents	Cents	Cents	Cents	Cents	Cents
1894.....	5.11	5.07	9.50	4.90	2.75	6.94
1895.....	5.74	5.69	9.85	5.25	2.86	7.44
1896.....	5.45	5.48	9.50	4.66	2.60	7.93
1897.....	4.73	4.75	9.25	4.70	2.48	7.00
1898.....	4.20*	4.10*	8.00*	3.96*	2.06*	5.94*
1899.....	5.28	5.13	9.50	4.25	2.69	6.88
1900.....	6.05	5.95	10.75	5.00	3.21	9.25
1901.....	5.54	5.48	10.25	4.62	2.84	8.75
1902.....	5.48	5.52	10.50	5.00	3.11	9.00

TABLE R

The following table is taken from U. S. Public Documents, no. 3074, vol. 1: 226.

England

RELATIVE PRICES					
YEAR	Cotton	Cotton Cloths	YEAR	Cotton	Cotton Cloths
1860	100.0	100.0	1884.....	92.9	69.1
1861	116.3	100.8	1885.....	94.8	66.4*
1862	184.7	103.8	1886.....	82.0	69.0
1863	378.3	177.5	1887.....	80.3*	68.2
1864	415.4	224.9**	1888.....	87.2	69.1
1865	422.7**	200.7	1889.....	89.9	70.1
1866	348.6	181.0	1890.....	93.5**	71.9**
1867	252.3	141.5	1891.....	81.5	70.9
1868	118.8*	89.6*	1892.....	70.5	67.1
1869	178.5	103.3	1893.....	82.6	68.7
1870	187.9**	105.6**
1871	132.9	92.9
1872	140.8	98.9
1873	138.4	99.9
1874	122.1	90.8
1875	111.7	91.3
1876	114.1	87.9
1877	97.4	90.4
1878	95.7	79.7
1879	77.2*	69.3*
1880	114.5**	73.9
1881	109.5	80.1**
1882	104.0	79.0
1883	90.6	72.5

TABLE S

The following data are from U. S. Public Documents, no. 3074, vol. 1: 321-22. Columns 28, 32, and 33 are the ones here compared.

France

EXPORT PRICES OF COMMODITIES			
YEAR	Silk Unbleached Raw Per pound	Silk Goods Pure Figured Per pound	Silk Goods Mixed Per pound
	\$	\$	\$
1861	4.85	11.81	6.65
1862	5.16	11.64	6.12
1863	4.94	11.11	6.56
1864	5.73	11.81	6.82
1865	6.69**	12.95**	7.52**
1866	6.65	12.86*	7.35
1867	7.13	13.21	7.26
1868	7.35	13.56	7.44
1869	6.30	14.88	7.52
1870	5.95*	14.09	7.17*
1871	7.00	14.44	7.39
1872	7.00**	15.05**	8.22
1873	5.95	14.35	8.75**
1874	4.72	12.86	7.17
1875	4.50	13.48	7.17
1876	5.99	12.95	7.00
1877	4.99	12.78	6.30
1878	4.37	11.29	4.90
1879	4.55	10.94	4.29
1880	4.29*	10.85*	4.20
1881	4.55**	11.20	4.20
1882	4.37	12.08	3.93
1883	4.11	12.60**	4.02
1884	3.85	10.50	3.76
1885	3.58	8.93	3.23
1886	3.58	9.10	3.32
1887	3.45	8.84	3.15
1888	3.37*	8.75*	2.88*
1889	3.63	9.10**	2.97
1890	3.76**	8.57	3.06
1891	3.06	8.57	3.23**

TABLE T

The relative prices for Germany are found in U. S. Public Documents, no. 3074, vol. 1: 296.

Germany

RELATIVE PRICES FOR GROUPS OF ARTICLES			
YEAR	Raw Materials	Half Products of Manufactures	Manufactures
1871	100.0	100.0	160.0
1872	110.3	119.6	107.6
1873	113.2**	125.8**	116.6**
1874	108.9	109.0	110.0
1875	107.1	103.0	112.0
1876	102.9	94.4	108.6
1877	97.9	88.0	100.6
1878	95.1	86.1	96.8
1879	91.0*	77.9*	94.6*
1880	94.7**	78.2	99.2
1881	92.7	78.8**	96.1
1882	94.5	77.6	98.1
1883	92.6	77.7	101.7**
1884	88.5	78.6	96.9

TABLE U

The data for wool and broadcloth are taken from U. S. Public Documents, no. 3074, vol. I: 36, 38.

YEAR	Broadcloth		Wool	
	First quality, black, 54-inch, XXX Wool	Second quality, black, 54-in., XX Wool	Wool, Ohio, medium fleece, scoured	Wool, Ohio, fine fleece, scoured
1850.....	111.2	124.0	81.0	81.2
1851.....	127.9	128.7	87.3	83.4
1852.....	122.3	124.0	79.9	79.8
1853.....	133.5	124.0	113.0	104.4
1854.....	111.2	102.0	91.5	89.0
1855.....	111.2	102.0	79.6	83.7
1856.....	122.3**	116.7**	96.1	102.2**
1857.....	111.2	100.0*	102.5**	99.5
1858.....	111.2	109.3	79.2*	80.5*
1859.....	100.0*	102.0	100.4	106.6
1860.....	100.0	100.0	100.0	100.0
1861.....	100.0	102.0	81.7	80.7
1862.....	111.2	131.3	107.7	91.7
1863.....	130.5	156.7	166.9	147.8
1864.....	223.4	253.3	195.8	172.7
1865.....	174.1	200.0	180.6	162.0
1866.....	162.9	200.0	138.7	128.0
1867.....	141.6	146.0	112.3	110.5
1868.....	140.1	153.3	99.6	86.6
1869.....	123.4	142.7	104.6	88.3
1870.....	123.4	142.7	97.9	87.6
1871.....	122.3	142.7	115.5	104.1
1872.....	122.3	142.7	155.3**	152.9**
1873.....	128.4	142.7	120.4	116.8
1874.....	128.4	142.7	117.6	112.4
1875.....	128.4	142.7	112.3	102.0
1876.....	128.4	142.7	95.4	84.9
1877.....	110.7	138.0	94.0	88.8
1878.....	99.0*	122.0*	88.7	72.9
1879.....	111.2**	131.3**	81.3*	70.0*
1880.....	108.6	128.7	118.0**	100.2**
1881.....	108.6	128.7	102.5	93.2
1882.....	106.6	128.7	101.4	88.3
1883.....	102.0	122.7	95.4	83.9
1884.....	100.0	116.7	83.1	78.5
1885.....	100.0	116.7	74.6*	69.5
1886.....	100.0	116.7	80.3	72.2
1887.....	100.0	116.7	85.9	71.5
1888.....	100.0	116.7	77.1	66.3*
1889.....	100.0	116.7	85.9	71.7
1890.....	100.0	116.7	83.5	71.5
1891.....	100.0	116.7	81.7	69.0

TABLE V

The following statistics of the total clearings at the London Bankers' Clearing House are given in millions of pounds sterling and are taken from the *Statistical Abstract for the United Kingdom*, 30:154, 45: 242, 51:246.

YEAR	Clearings	YEAR	Clearings	YEAR *	Clearings
1868	3,466*	1884	5,799	1895	7,595
1869	3,602	1885	5,511*	1896	7,575
1870	3,905	1886	5,902	1897	7,491
1871	4,787	1887	6,077	1898	8,097
1872	5,893	1888	6,942	1899	9,150**
1873	6,182**	1889	7,619	1900	8,960
		1890	7,801**		
1874	5,916			1901	9,561
1875	5,647	1891	6,848	1902	10,029
1876	4,959*	1892	6,482	1903	10,120
1877	5,018	1893	6,478
1878	5,007	1894	6,337*
1879	4,959
1880	5,718
1881	6,335**
1882	6,235
1883	5,929

TABLE W

The figures for clearings at the New York clearing house, 1854-1899, are from Cannon's *Clearing Houses*, 203. The remainder are taken from the *World Almanac and Encyclopedia*, 1906: 167. The sums are in millions of dollars.

Fiscal Year Ending Sept. 30	Clearings	Fiscal Year Ending Sept. 30	Clearings	Fiscal Year Ending Sept. 30	Clearings
.....	1874.....	22.8	1894.....	24.2*
1854.....	5.7	1875.....	25.1	1895.....	28.2
1855.....	5.4	1876.....	21.6*	1896.....	29.3
1856.....	6.9	1877.....	23.3	1897.....	31.3
1857.....	8.3**	1878.....	22.5	1898.....	39.8
.....	1879.....	25.2	1899.....	57.4
1858.....	4.7*	1880.....	37.9	1900.....	52.0
1859.....	6.4	1881.....	48.6**	1901.....	77.0**
1860.....	7.2	1882.....	46.5	1902.....	74.8
1861.....	5.9	1883.....	40.3	1903.....	70.8
1862.....	6.9	1884.....	34.1
1863.....	14.9
1864.....	24.1	1885.....	25.2*
1865.....	26.0	1886.....	33.4
1866.....	28.7	1887.....	34.9
1867.....	26.7	1888.....	30.9
1868.....	28.5	1889.....	34.8
1869.....	37.4	1890.....	37.7**
1870.....	27.8	1891.....	34.0
1871.....	29.3	1892.....	36.3
1872.....	33.8	1893.....	34.4
1873.....	35.5**

Volumes I, II, III, IV, V, and VI, of UNIVERSITY STUDIES are each complete in four numbers.

Index and title-page for each volume are published separately.

A list of the papers printed in the first two volumes may be had on application.

Single numbers (excepting vol. II, no. 3) may be had for \$1.00 each.

A few copies of volumes I, II, III, IV, V, and VI, complete in numbers, are still to be had.

All communications regarding purchase or exchange should be addressed to

THE UNIVERSITY OF NEBRASKA LIBRARY

LINCOLN, NEB., U. S. A.

2N3

AS 36.N2

VOL. VII

April 1907

No. 2

UNIVERSITY STUDIES

Published by the University of Nebraska

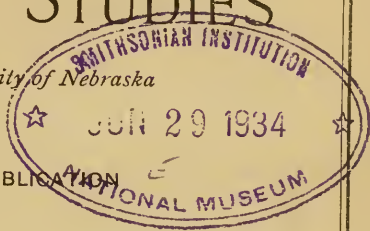

COMMITTEE OF PUBLICATION

C. E. BESSEY
 T. L. BOLTON
 F. M. FLING

H. ALICE HOWELL
 W. K. JEWETT
 L. A. SHERMAN

W. G. L. TAYLOR

CONTENTS

I	FATIGUE AND THE RECOVERY OF THE PHOTO-ELECTRIC CURRENT <i>W. F. Holman</i>	125
II	SOME VARIATIONS IN HYMENOLEPIS DIMINUTA <i>Lazelle B. Sturdevant</i>	135
III	A STUDY OF SOME GREGARINES WITH ESPECIAL REFERENCE TO HIRMOCYSTIS RIGIDA F. SP. <i>Maurice Crowther Hall</i>	149
IV	ON THE RELATION OF MUSCLE SENSE TO PRESSURE SENSE <i>T. L. Bolton and Donna L. Withey</i>	175

LINCOLN NEBRASKA

UNIVERSITY STUDIES

VOL. VII

APRIL 1907.

No 2

I.—*Fatigue and Recovery of the Photo-Electric Current*¹

BY W. F. HOLMAN

The experiments of H. A. Wilson² showing that the escape of negative electricity from incandescent platinum disappears when the metal is freed from absorbed hydrogen, and those of Skinner,³ that in the glow current through rarefied gases hydrogen atoms serve as carriers of negative electricity from metallic cathodes to the gas, suggest the possibility of the absorbed gas playing a part in the escape of negative electricity from a metal subjected to ultra-violet radiations. In fact, the experiments of Wulf⁴ indicate that the presence of absorbed hydrogen increases the photo-electric current from platinum, in that after the platinum has been allowed to stand in an atmosphere of hydrogen for some time there is a marked increase of the current over that obtained in air, and again a decrease as the metal supposedly loses its charge of hydrogen.

This photo-electric current depends on two principal factors, first that arising from the escape of negative carriers from the

¹Read in part before the joint meeting of the American Physical Society and section B of the American Association for the Advancement of Science, Ithaca, June, 1906.

²*Phil. Trans.*, 202, p. 243. 1903.

³*Phys. Rev.*, XI, p. 1. 1905.

⁴*Ann. d. Physik*, 9, p. 946. 1902.

metal, and, secondly, that from the ionization of the gas by these carriers. Thus the experiments of Stoletow,¹ Lenard,² and Varley³ show that as the gas pressure is reduced indefinitely the photo-electric current drops to a definite minimum value, which thereafter remains practically constant for all values of the electric field. This is considered as that arising solely from the carriers escaping from the metal. On the other hand, when the discharge takes place in an atmosphere of appreciable density the current may be produced largely by the second factor, the ionization of the gas by the motion of these escaping carriers. For instance, Kreussler⁴ found that in air at atmospheric pressure the current increases very rapidly with the electric intensity, if the latter approaches that required to produce a spark discharge.

The present investigation was undertaken, therefore, with the intention of studying the current arising from the escaping carriers alone, as it is affected by changing the store of hydrogen in the surface of the metal. The results were such as to include a study of certain phases of the so-called *fatigue* and *recovery* of the metal under the conditions of operation.

The plan which suggested itself as most likely to yield conclusive results was based on the discovery of Skinner that as cathode in a glow current the metal gives off hydrogen, while as anode it absorbs it. In case, therefore, these conditions can be brought about without otherwise affecting the surface of the metal, this plan furnishes a simple scheme for making a test of the effect of changing the quantity of hydrogen in the metal. As will be seen, however, this condition was attained without question only in one series of experiments.

¹*Jour. de Phys.*, 9, p. 468. 1890.

²*Ann. d. Physik*, 2, p. 359. 1900.

³*Phil. Trans.*, 202. 1903.

⁴*Ann. d. Physik*, 6, p. 398. 1901.

EXPERIMENTAL ARRANGEMENT

Figure 1 presents a diagram of the system used. An electric arc, *A*, operated in parallel with a capacity, *K*, by an induction coil fed by a fifty-volt alternating current, served as source of light. This arc was focused by a quartz lens, *L*, through a window, *Q*, of same material on the cathode, *E*, charged from a battery, *B*.

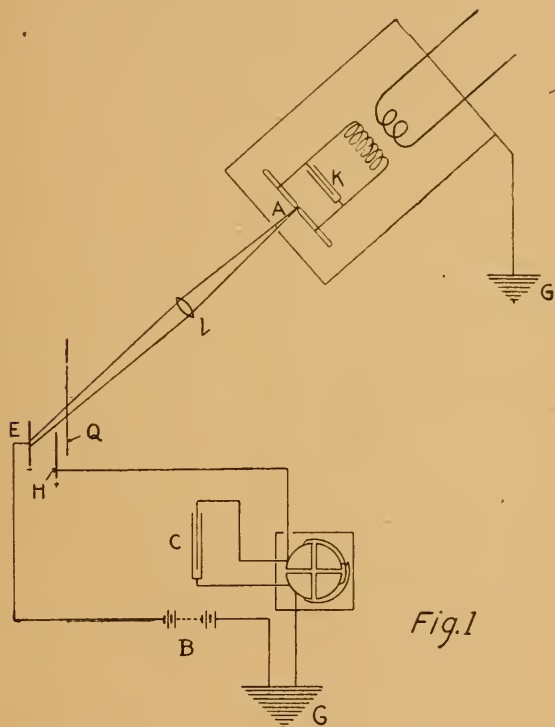
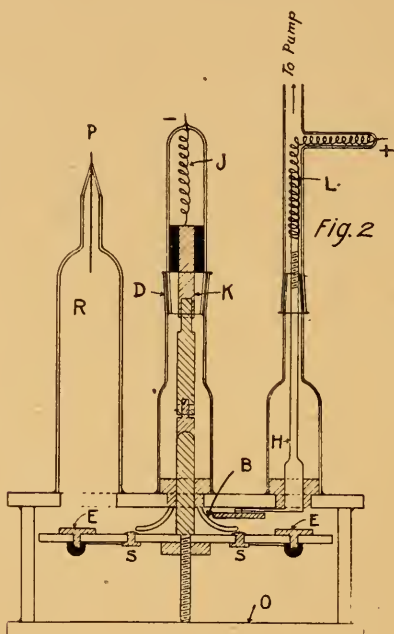

Fig.1

The current of negative electricity from *E* to the anode, *H*, placed opposite, was determined by measuring the rate with which a definite capacity, *C*, connected to the latter, was charged. For this purpose a Thomson quadrant electrometer was employed in the customary manner. The positive pole of the battery and the

other terminal of the condenser, *C*, were connected to earth. Both the electrometer and the arc system were enclosed in grounded metal cases. Spurious effects were corrected for in all cases by taking observations with the electrode simply screened from the light, other conditions remaining the same.

The electrode chamber is shown in vertical section and plan in figures 2 and 3. It was designed for testing several metals successively. These were in form of disks, *E*, mounted on the face of



a circular glass plate which could be rotated at will about a supporting axis of brass by means of the ground joint, *D*, and key, *K*. The electrical connections were made through *J*, the supporting axis, and the spring brush, *B*, to the contact, *S*, connected by tin-foil strips (placed under the plate) to the cathode, *E*. The connection with the fixed aluminium anode was made through its supporting arm, *H*, and the wire, *L*. In order to use the metals, *E*,

as electrodes with a glow discharge, a tube, R , with an additional electrode, P , was attached to the chamber as indicated. For this purpose a second spring brush similar to B served as connection. The arrangement was such as to insulate all electrodes except the one in action. All fixed joints which could not be fused were sealed with de Khotinsky's laboratory cement. The chamber proved to be perfectly air-tight. The electrodes could be renewed by removing the base plate, O , which permitted the plate carrying them to be taken out.

In the vacuum system all stop-cocks and ground joints were lubricated with a mixture recommended by Travers as free of hydrocarbons. Evacuation was produced by a Rapps automatic

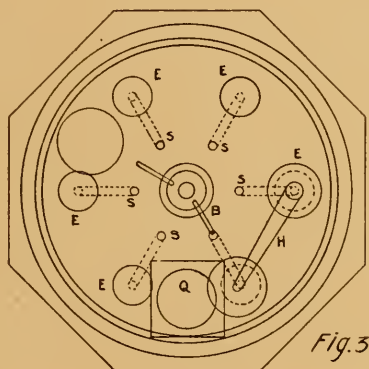

Fig. 5

pump. A McLeod gage, multiplying the pressure about ten thousand times, served as pressure indicator. P_2O_5 was used as dryer. A battery of small accumulators served as source of potential.

For an electric arc that found by Varley to be most satisfactory, namely steel electrodes in a slow stream of hydrogen, was used. It proved to be much more constant than other sources tried.

The capacity, C , consisted of an air condenser of tin-foil mounted on plane glass plates insulated with quartz.

EXPERIMENTS

Zinc, carefully polished and cleaned, was tested first. This was mounted in the electrode chamber, which was immediately evacuated and left at an indefinitely low pressure in connection with the drying chamber for several hours.

With a gas pressure of .001 mm., a P. D. of about 500 volts,¹ and a capacity, *C*, of about 1,400 cm., the photo-electric current produced in ten seconds the following series of deflections of the electrometer (8.5 scale divisions=one volt). The arc was stopped after each reading and started anew for the next.

TABLE I

33.4	32.5	32.6
34.4	32.7	31.5
32.9	33.4	30.0
27.0	33.5	30.5
		32.0
	Mean.....	32.0

This value is equivalent to 6×10^{-10} amperes. After admitting hydrogen at a pressure of 1.5 mm., a glow current was then sent from the zinc as cathode for about fifteen minutes, and the chamber again evacuated to a pressure less than .001 mm. The photo-electric current observed at this point gave the following successive values:

TABLE II

20.2	20.2	20.4
20.5	16.1	19.8
20.2	19.5	20.6
20.2	20.6	21.1
		20.0
	Mean.....	20.0

representing a current of 3.8×10^{-10} amperes, which is a marked decrease compared with the fresh metal.

¹At the pressures used the photo-electric current proved in all cases wholly independent of the magnitude of the P. D. between the electrodes.

After standing then twelve hours, the following series of observations was taken under the same conditions as before :

TABLE III

21.3	20.9	21.7
21.5	21.8	22.7
21.3	21.9	22.5
17.7	22.7	22.3
		Mean.....21.5

representing 4.1×10^{-10} amperes. This shows only a comparatively slight increase over the values obtained twelve hours before. Following this, hydrogen was again admitted and the metal used in this case as *anode* during a period of about seven minutes, after which the chamber was evacuated to less than .001 mm. and the following series of values obtained for the photo electric current.

TABLE IV

27.5	31.4	32.0
28.0	33.0	32.5
30.1	32.7	32.2
31.5	32.2	..
		Mean.....31.2

or a current of about 5.9×10^{-10} amperes which is strikingly close to the first values as given in table I.

The above results are readily explained in the light of Skinner's experiments if we assume that hydrogen may also serve as carrier of negative electricity in the photo-electric current. With the unused metal the photo-electric current was 6×10^{-10} amperes. By use as cathode with a glow current the quantity of hydrogen present was undoubtedly considerably reduced. The photo-electric current in this condition was also reduced to about two-thirds its original value, 3.8×10^{-10} amperes. Left at rest for several hours the metal indicated practically no change from this last value, but after use as anode in hydrogen—which charges the metal with this gas—the photo-electric current re-

turned to its original magnitude. The same explanation, however, may be given by assuming a migration of electrons with the negative current, and the possibility of appreciably changing their available number in the metal in the same way as the quantity of hydrogen is changed.

A repetition of the above experiments with several different metals brought to light an entirely different set of influences. With electrodes freshly polished the electrode chamber was left at extreme vacuum in connection with the dryer for several hours, after which the photo-electric current was tested as before in an atmosphere of less than .001 mm. pressure. The mean results of a number of tests, in which the individual observations revealed about the same fluctuation in value as those in the previous experiments, are given in table V. In this series the capacity, *C*, was about 2,800 cm., other conditions as before.

TABLE V

	PHOTO-ELECTRIC CURRENT (10^{-10} AMPERES)				
	Zinc	Copper	Silver	Aluminium	Iron
After using as cathode with glow current in hydrogen	16.0	11.6	6.4	0.6	0.6
After standing 12 hours in hydrogen	8.8	1.8	0.6	0.0	0.0
After again using as cathode	41.0	16.0	14.0	5.0	4.5
After using as anode in hydrogen	7.0	15.0	6.0	1.3	1.4
After using as cathode again	36.0	16.5	25.0	2.7	5.0
After standing in hydrogen several hours	28.0	9.3	16.0	2.5	3.2

A striking feature in these results is the exceptionally large value of the photo-electric current of zinc as compared with the previous tests—the magnitude in one case being as much as seven times as high as the largest values before, and in no case dropping as low as the maximum value previously obtained. In these experiments it is to be noted that after use as cathode the current is greatest, and after standing in hydrogen or used as anode it is generally considerably smaller, the different metals

being affected in different degrees. The probable explanation is, that use as anode or even contact with the gas (possibly not entirely pure) tarnished the surface of the metal, and this reduced, as is known, the photo-electric action. By use as cathode with the glow discharge the metal surface in these tests was probably cleaned of tarnish but not sufficiently depleted of its negative carriers to reduce the photo-electric current.

It was thought possible to obtain less complicated results by operating with the glow discharge in argon instead of hydrogen, since, according to Skinner, use as cathode in this gas serves to deplete the store of hydrogen, while use as anode has no appreciable effect. The results obtained are recorded in table VI. For these experiments, the capacity, *C*, was again reduced to 1.400 cm.

TABLE VI

	PHOTO-ELECTRIC CURRENT (10^{-10} AMPERES)				
	Zinc	Copper	Silver	Aluminium	Iron
After standing in vacuo.....	1.2	0.5	0.9	1.2	0.2
After use as anode with glow current in argon	1.2	13.0	5.0	0.4	0.7
After use as cathode in argon..	19.0	11.6	6.3	1.4	0.7
After standing in hydrogen for several hours	2.4	9.0	1.0	0.5	1.2

The results here are very similar to those recorded in table V, with the exception that the use of copper and silver as anode with a glow current in argon appears to clean the metal of its tarnish, in that it increases its photo-electric current. It should be remarked that in no case did a *visible* tarnish appear when argon was used.

Although the results given in tables I-IV could not be duplicated, they are so definite that it seems probable that the desired state of depletion of the metal by use as cathode was not reached in the later experiments. Unfortunately further prosecution of the investigation was impossible.

II.—*Some Variations in Hymenolepis diminuta*

BY LAZELLE B. STURDEVANT

The work on this paper was begun in September, 1903, and was nearly completed, when there was published by Ransom (1904), "*An Account of the Tapeworms of the Genus Hymenolepis Parasitic in Man.*" This paper is a review of all that is known concerning the three species of the genus *Hymenolepis* which have been found in the human subject. Of these *H. nana* is fairly common, *H. diminuta* is very rare, and *H. lanccolata* has been recorded but once as a parasite in man. Ransom's paper contains a full discussion of the literature, with translated abstracts from the earlier and from the more important later works on these forms. It also includes an anatomical description, an account of development and life history, abstracts of all known cases of human infection, with an analysis of these and discussion of symptoms, together with the diagnosis, treatment, and prophylaxis for each of these parasites. The paper contains a great number of figures, almost all of which are copied from various authors. A complete bibliography concludes this valuable contribution to medical science, to which the reader is referred for a review of the literature.

Ransom's work has also anticipated much that I had worked out. Of importance are, however, my data on the degree of infection and on some variations in the species *H. diminuta*, which are recorded in this paper. My specimens of this parasite were obtained from the small intestine of the common brown or Norway rat (*Mus decumanus* Pallas). They were fixed in a killing mixture for cestodes, consisting of equal parts of saturated aque-

¹Studies from the Zoological Laboratory, The University of Nebraska, under the direction of Henry B. Ward, No. 76.

ous solution of corrosive sublimate and 70 per cent alcohol with a trace of glacial acetic acid. For catching the hosts of this worm I have found the genuine Marty trap an absolute necessity. I have, where possible, killed and examined the animals on the same day that they were captured.

This paper was prepared under the direction of Dr. Henry B. Ward, to whom I here express my sincere thanks for innumerable suggestions and valuable assistance. I am indebted to Mr. I. J. Clark for a portion of my collection data.

DEGREE OF INFECTION OF RATS EXAMINED

Of the 103 rats examined 27 (26 per cent) were free from internal macroscopic parasites. Of these 7 were infested with ectoparasites and 2 others harbored a trypanosome in the blood.

The stomach was infected with nematodes in three cases (2.9 per cent); from one to six worms were present in each case with an average of three. They were free in the contents of the stomach in two cases, but attached to the wall in a third. In these three rats from 7 to 100 cestodes were present in each case. Two nematodes were found in the small intestine in one of these cases and in this rat two acephalic cestodes were also found in the stomach along with the nematodes mentioned above. This last condition is to be explained by reversed peristalsis, since the animal was not examined until several hours after death, and serves to emphasize the necessity of immediate examination. One of these hosts harbored a cysticercus in the liver, while one contained a cyst in that organ. Ectoparasites were found in one case and trypanosomes in the blood of this same host.

Including the three cases just discussed, 67 rats (65 per cent) harbored a total of 1,695 cestodes by actual count, except in one case where an estimation of 100 was made. The minimum infection was 1 cestode, the maximum 137, the average 25. From September to December inclusive the minimum percentage of rats harboring cestodes was 62.5 in September, the maximum 67.8 in November. The average number of cestodes found in each case varied from a minimum of 9 in September to 28 in No-

ember. The male hosts captured from month to month always outnumbered the females by a few individuals. Nematodes in the bladder were not found during September and October but were abundant in December, when I found 9 rats infected with 42 worms, while the nematodes were present in small numbers (1 to 5) during the other months.

The blood of the rats was examined for trypanosomes, beginning with host No. 44 and extending to the end of the series. Thirteen were found to be infected, eight abundantly and five less so. Seven rats infected with trypanosomes in December are closely seconded by five in November with one case in January following. Examinations for this parasite were not made until November 24. In all, this makes 13 cases in 46 rats (28.2 per cent); among these rats nematodes were found in the small intestine in five cases, one or two worms in each, in all seven. One case was found in September, three in October, one in November, and none during December, January, and February.

But one cysticercus was found in each case infected, the organ concerned being the liver. Four cases in September were followed by three in October and one in November, after which none were found. From October to December inclusive ripe proglottides of *Hymenolepis* were occasionally found in the large intestine, in three cases even one or two cestodes, which, however, were minute, except one specimen of about five centimeters in length and without a scolex. These would soon have passed to the outside.

While keeping the rats for examination, I have usually fed them with shelled corn, and fearing lest this should aid in expelling the cestodes from the intestine, I have recorded the length of time the animals have been kept before being killed, for the purpose of comparison. In those animals which were killed on the day when caught, I obtained an average infection of 26 cestodes, in those kept alive for 1 day an average of 2, for 2 days an average of 14, for 3 days 31, for 5 days 49, for 6 days 41, for 7 days 55, and for 11 days 137. There is thus nothing to justify the suspicion. Corn may then be regarded as one of the very best foods for rats captured alive and retained a while before exam-

ination. Aside from its convenience, it can easily be cleaned, and it replaces the fibrous contents of the intestine so that the worms need but little washing to make them clean.

In one of the thirteen rats infected with trypanosomes in the blood the bladder harbored two nematodes; in another three. Nearly all of the thirteen were kept alive for several days (3-5), but it is hardly possible that infection may have taken place in this laboratory. Ectoparasites were absent in most cases. Of those examined for sex, eight were male and two were female. Three cases showed small cysts in the liver. Ten harbored cestodes varying in number from 1 to 93; all were caught during November, December, and early January. All but two were from one restaurant, the other two being captured but ten or twenty yards distant from this. One rat was infected with six nematodes in the stomach. Only one was full grown, while eight were half grown or smaller.

The five rats which harbored nematodes in the small intestines were of all sizes, came from a variety of places, and all harbored cestodes, from 1 to 100 in each case. They were all caught during September, October, and November. Three were males and one female. One had two nematodes in the stomach. Ectoparasites were present in one case. No case was infected with trypanosomes or with nematodes in the bladder. *Hymenolepis murina* was found in one case. Twenty-one rats (20.4 per cent) harbored nematodes in the bladder. Sixteen of these were full grown, but one was less than two-thirds grown. They came from a great variety of places. Sixteen contained cestodes in the small intestine, from 1 to 50 in number. In six, small cysts were noted in the liver. Eight were males and four were females. Ectoparasites were observed in a third of the cases. Most of them were killed on the day captured. Two cases showed trypanosomes in the blood. In twenty cases, sixty-six nematodes were found, an average infection of three worms, but varying from 1 to 17. In the twenty-first case the nematodes were too numerous and too badly tangled to be accurately counted. One worm among these was red, but lost its color after lying in alcohol for a time.

Of the hosts examined for sex forty-two were males and twenty-six were females. This difference probably represents a greater number of males present in nature rather than any special factor which leads the female to avoid traps. All sizes, all places, and all months were about proportionately represented in both sexes. Males and females were about equally infected with cestodes. But one cysticercus was found among the males as compared with four among the females. Both sexes were infected frequently with ectoparasites, with nematodes in the bladder and with trypanosomes in the blood. With regard to the last the males showed eight cases of infection, the females two.

The size of the host does not seem to be a very important factor except with regard to infection of the blood with trypanosomes and nematodes in the bladder. The full-grown rats came from a great variety of places, and were caught during all the months. The same is true of the smaller animals. Size is independent of sex also. Nematodes in the bladder are rather characteristic of the full-grown and trypanosomes in the blood of the half-grown rats. Of the full-grown animals 73 per cent are infected with cestodes as compared with 61.5 per cent of those half-grown. As a rule a smaller number of worms is found in a cestode infection of a full-grown rat, 11.9 on the average, than of a half-grown specimen, averaging 27.8.

The effect of place where the rat was captured had very little to do with the infection by parasites. It has apparently no effect on size or sex of the animals. Eleven of the thirteen cases of trypanosome infection were from a single restaurant. The rats were obtained from eighteen different places, 46, the largest number, coming from a single place, the restaurant just mentioned. One animal from each of several places was secured. The number from each place thus varies too greatly and is too small in many cases to indicate valuable results.

DESCRIPTION OF AN UNUSUAL SPECIMEN OF *H. diminuta*

This specimen was taken from the small intestine of a full-grown brown or Norway rat (*Mus decumanus* Pallas).

The length of *Hymenolepis diminuta* is given as from 10 to 60 cm., but this specimen measures 99 cm., and if the length of the loose portion of ripe proglottides found in the large intestines and coming from this worm be added, the total length reaches one meter. This is certainly phenomenal, as the next longest worm in my collection coming from specimens of the rat is but 40.2 cm. long. This longest specimen was attached to the wall of the small intestine within less than a centimeter of the pylorus and extended throughout the length of the small intestine to within 1 cm. of the opening into the large intestine. It was thus in life about equal to the length of the small intestine of the full-grown rat in which it was found, and that is about 1.5 m. in length. In the fixing fluid it contracted to about two-thirds of its original length, though even then the proglottides remained longer than is usual in this species.

The width of this specimen at 20 cm. from the head is 1.8 mm. and gradually increases to 2.8 mm. at 40 cm. At 60 cm. it is 3.1 mm., at about 80 cm. it reaches its maximum width, 3.3 mm., gradually decreasing from here to the end, where the width measures 2.5 mm. The maximum width is given as 4 mm., the figure given by Packard (7 mm.) for his specimen from the human subject being regarded as doubtful. The scolex is subject to great variation in regard to size and shape. Some of the more usual shapes it assumes in the fixing fluid are shown in figures 1, 2, 11, and 12, the last showing the form of the scolex of the long specimen. In life the head is constantly changing in form as the musculature of that region acts. The suckers or rostellum or both may be extended or retracted in a great variety of ways, as well as the scolex as a whole. In general the scolex is more or less truncated or globular but flattened somewhat dorsoventrally. The width of the head is given as 200 to 600 μ ; in the specimen under consideration it is 190 μ between the suckers with a dorsoventral measurement of 151 μ . The four suckers, spherical in

form, are placed more or less anteriorly and measure from 80 to 160 μ in diameter, in this specimen only 86 μ , close to the minimum. A small rostellum without hooks is found at the anterior point of the scolex. It is slightly retractile and may be withdrawn inward, leaving a shallow pocket or hollow at the anterior tip. On the other hand, it may be protruded, giving the head a bluntly pointed appearance. The rostellum is a pyriform muscular sac with an outer layer of longitudinal and an internal of circular fibers. The large end is anteriorly; it is surrounded by the parenchyma of the scolex. According to Ransom, when retracted the anterior portion is invaginated, forming a tube-like cavity extending inward from the anterior surface of the scolex into the middle of the rostellum and lined with cuticula continuous with that of the external surface of the parasite. This is best seen in the living worm. In this long specimen the rostellum shows nothing more than a shallow depression anteriorly. The excretory vessels within the rostellum described by Ransom as consisting of two loops here have the appearance of an irregular network or system of lacunae.

The shape of the rostellum is not strictly pyriform in this specimen, since there are four somewhat concave surfaces corresponding to the proximity of the four spherical suckers. It measures 39 μ in width at about 30 μ from the anterior end, and runs throughout the eleven sections of 10 μ each. The thickness in this case is apparently greater, due probably to a slightly oblique section. These measurements were made from sections. In almost all of my scolices mounted in toto the rostellum has a length of 93 μ with a width usually of 53 μ , in the lowest case 40 μ . The neck is always short, as Grassi gives it at 0.5 mm. It may equal or exceed in width the scolex, as is shown in figures 2 and 11, but is generally not so wide (figs. 1, 12).

The greatest number of proglottides yet given for this form is 1,300 by Magalhães. My specimen by actual count possesses over 2,850. The youngest proglottides are 23 μ by 270 μ , eleven times as wide as long. Twenty cm. from the scolex in toto mounts they measure 240 μ by 1,650 μ or nearly seven times as wide as long. At 40 cm. from the scolex they measure 300 μ by

3,000 μ , or ten times as broad as long. At 60 cm. from the scolex they are 450 μ by 2,820 μ , or six times as broad as long. At 80 cm. from the scolex 900 μ by 2,910 μ , or three times as broad as long. At the end of the strobila they are 660 μ by 2,760 μ , or four times wider than long. This shows that disproportionate contraction has occurred throughout the strobila.

Figure 9 shows a few proglottides from this specimen at 20 cm. from the scolex. To what extreme the longitudinal contraction may be carried in the process of fixing is shown in figure 5 from another one of my specimens, where, at one-fifth of the total length of the strobila from the head, the proglottides measure 100 μ by 2,280 μ or nearly twenty-three times as broad as long. These measurements are taken midway between anterior and posterior borders. The serration throughout the strobila is not so striking, since the posterior border of each proglottid only slightly exceeds in length the anterior border of the proglottid following. The lateral margin of each proglottid usually shows a slightly convex outline, while the postero-lateral angle is rather blunt. Ripe proglottides are usually given off from the end of the worm in groups of from two or three up to fifteen in each. The decrease in width and the concavo-convex outline of the proglottides increasing toward either end of the group are rather characteristic. One group coming from my longest specimen contains fifteen proglottides.

The genital pores are regularly unilateral and on the left side at the junction of the anterior and middle thirds of the proglottid. Occasionally a proglottid may be found where the genital pore is on the right side. My specimen is not new in that regard. I have not observed calcareous bodies in my specimen, since there was a trace of acetic acid in the fixing fluid and the worm was destained in acid (HCl) alcohol. Ransom describes them as oval, measuring 8 to 13 by 4 to 6 μ . They are usually rare in this species. The nervous system in this species has been described by Zschokke. Throughout the strobila may be found two large longitudinal nerves, one near either border of the worm. Just above and below each of these (dorsad and ventrad) may be found an accessory longitudinal nerve; hence two on either side,

or four altogether. In the anterior and also in the posterior regions of each proglottid is found a ganglionic enlargement from which arise two nerves, one running inward in the cortical portion and one in the central portion of the parenchyma. In the scolex the nerve trunks unite behind the rostellum in a commissure richly supplied with nerve cells. From here arise four nerves running forward on as many sides of the rostellum and containing nervous elements. These main structures are all I have made out in my specimen.

The subcuticular musculature consists here, as is usual in cestodes, of an outer layer of circularly running fibers and an inner layer just internal, of longitudinal fibers. These are united into minute bundles, between which the processes of the subcuticular cells pass upward, to become continuous with the cuticula.

The body musculature consists of longitudinal, transverse, and dorsoventral fibers. The longitudinal are united into small bundles of 8 to 15 fibers each. The bundles are arranged in two layers: the outer, just beneath the subcuticular cells, and arising from subcuticular longitudinal bundles in the scolex and neck, are the more numerous by far; the inner are attached in the scolex to the suckers and rostellum. In the worm under consideration these two layers are so close together that they might readily be mistaken for one, due to unusual muscular contraction of the dorsoventral fibers. The transverse and dorsoventral fibers are alike few in number, especially in the middle region of each proglottid; the latter are perhaps the more common.

The two ventral canals are the most important of the excretory system and run throughout the length of the strobila to the inner side of the longitudinal nerves, sometimes with a lateral curve in each proglottid. They are connected with each other by a transverse canal having a slightly undulating course and somewhat smaller diameter near the posterior margin in each proglottid. Just above each of them is the corresponding dorsal canal, very much smaller in diameter and only equal in size near the scolex, where the ventral canal is found to be much smaller. The four canals terminate in the vascular ring behind the rostellum in the scolex. From this ring run forward four vessels, those on either

the right or left side of the rostellum uniting to form a dorsoventral loop. Two similar dorsoventral loops within the rostellum have also been described by Ransom, but are hard to demonstrate in my specimen. These canals are all circular in cross-section, but in the specimen at hand the ventral and dorsal canals appear to be greatly compressed in the dorsoventral direction, giving the large or ventral canals a spindle-shaped cross-section. This is caused by the unusual contraction of the dorsoventral muscular fibers, already mentioned. The appearance of the transverse canals in figure 6 is due to their undulating course, which hence occasionally gives them a dumb-bell outline in section.

The male organs of reproduction consist of testes, vasa efferentia, vas deferens, seminal vesicle, cirrus pouch, and cirrus. The testes are regularly three in number, occasionally two (fig. 4) or four (figs. 3, 8), oval or discoidal or even globular in shape, depending on the proportionate contraction of longitudinal, transverse, and dorsoventral muscular fibers. In toto mounts the testes most frequently measure 93μ long and 120μ wide, although they are occasionally found 107μ long by 93μ wide. The usual position of the testes is in a row across the proglottid (figs. 3-9), one being on the left side of the ovary, the other two being on the right. When but two testes are present they are found one on either side of the ovary (fig. 4). When four are present one is found to the left, the other three to the right (figs. 3, 8). An unusual arrangement which Grassi has figured, where two testes are found to the left and one to the right of the ovary I have shown in figure 7. Another very exceptional arrangement of the three testes shows them all on the right side of the ovary (fig. 9). In one proglottid in figure 4, the testes are not found in a row, but two to the right of the ovary are one behind the other almost in a longitudinal axis.

From the dorsal side of the testes, arise the vasa efferentia, one from each, and converge toward the median axis of the worm, where they unite to form the vas deferens, which proceeds toward the left margin of the proglottid lying close to its anterior border. After the vas deferens has passed the isolated testis, it

forms a large dilatation, the seminal vesicle, from which it continues as a canal to the cirrus pouch, which it enters and traverses, becoming muscular and finally forming the slender cirrus shown partly in longitudinal section in figure 10. The cirrus pouch is a muscular sac-like structure with circular and longitudinal fibers best developed, although oblique fibers may be frequently observed.

The cirrus pouch opens externally at the genital pore. The position of the genital pore is on the left border of the proglottid, as it is usually stated, at the junction of the anterior and middle thirds. From an extensive series of measurements I have concluded that the position of this pore is not so constant and may vary somewhat in different specimens and even in different proglottides of the same strobila. In making these measurements I have taken the distance from the genital pore to the posterior border of the proglottid as compared with the distance from the pore to the posterior border of the proglottid preceding. The former distance in one proglottid at 20 cm. from the scolex in my long specimen was 93 μ , the latter distance was 133 μ . In the next proglottid following, as also in the third, these distances were 107 and 147 μ respectively; in the fourth and fifth proglottides they were 107 and 133 μ ; in the sixth 93 and 133 μ ; in the seventh 80 and 133 μ ; in the eighth 93 and 120 μ ; in the ninth 93 and 107 μ ; in the tenth 93 and 120 μ . The genital pore is hence a little more than half way down on the left border of the proglottid. This is partly due to the slight degree of contraction in the longitudinal direction. Among the female organs variations are less prominent. The female apparatus consists of vagina, seminal receptacle, the seminal canal, the ovary, oviduct, shell gland, yolk gland or vitellarium, yolk duct, and lastly the uterus, which has no external opening.

The vagina is a rather straight, narrow, muscular tube running inward from the genital pore and ventrally to the cirrus pouch. At a third to one-half the distance inward it gradually enlarges to form the dilatation which continues almost to the median line and is known as the seminal receptacle, a clavate muscular sac which contains the sperm from the male system. The

seminal receptacle is the last of the genital organs to assume any considerable size, and persists almost to the end of the strobila in each proglottid. This organ was the "yellow spot" of Weinland's description. From the large rounded termination of the seminal receptacle, a small short duct, the seminal duct, proceeds to join the oviduct, which is a slender canal, coming forward from the isthmus of the ovary. After receiving the seminal duct, the oviduct changes its direction, running downward and backward to the small shell gland lying in the median line. Here it is joined by the yolk or vitelline duct from the gland of the same name and lying also in the median line but close to the posterior border of the proglottid. From the shell gland the oviduct proceeds anteriorly to the uterus, which lies along the anterior border of the proglottid and dorsally to the ovary.

The uterus in the earlier stage is merely a transverse strand of cells, which later becomes hollow and grows to the right and left. On reaching the right margin of the proglottid, as it continues to receive eggs, it forms a loop by growing around the testes and developing along the posterior border of the proglottid until the left margin is here reached. Further development of these two main tubes is by outpocketings until the entire proglottid is filled by the structure, while the other organs in the meantime gradually become smaller and at last disappear. Cross tubes between these main portions are frequently present. These relations were first worked out by Zschokke. The nuclei of the parenchyma usually persist longest so that on the walls of the uterus are frequently found minute knobs, where the parenchyma has not yet given way to the development of the uterus and which stain very deeply. My longest specimen shows no peculiar differences in the case of this organ.

The ovary is bilobed, the two portions being connected by an isthmus which is short and thick or sometimes longer and more slender. Each lobe is made up of lobules, which may be short and thick as in my specimen and as Grassi (1888) figured, or long and slender as shown by Zschokke (1888). In one of Grassi's figures the ovary has a distinctly rosette-like appearance. The yolk gland has a general lenticular shape and is made up of

a few thick, rounded lobes. The anterior margin of this gland is constantly very convex, while the posterior may show two, three, or four lobes projecting backward.

Ransom has given measurements for the egg of this form from both the rat and man. The outer shell varied from 64 to 80 μ ; the inner, 24 by 20 μ to 36 by 28 μ ; the hooks, 14 to 16 μ . A few smaller eggs with thicker shell measured 40 by 40 μ to 40 by 48 μ . (Ransom, 1904). All my measurements have easily fallen within these limits except a very few of the largest, where the external shell measured 84 μ , a figure exceeded by Grassi's maximum of 86 μ . I have found "sterile" proglottides quite frequently, but in the specimen I have described they do not seem to be so common.

LITERATURE CITED

Grassi, B.

1888. *Taenia flavopunctata* Weinland, *Taenia leptoccephala* Creplin, *Taenia diminuta* Rudolphi. Atti. R. Accad. d. sc. Torino., 23:492-501; 1 tav.

Magalhães, P. S. de.

1896. Ein zweiter Fall von *Hymenolepis diminuta* Rudolphi (*Taenia flavopunctata* Weinland) als Menschlicher Parasit in Brasilien beobachtet. Centr. Bakt. u. Par., 1 Abt., 20:673-74.

Packard, F. A.

1900. *T. flavopunctata* with the description of a new specimen. Jour. Amer. Med. Assn., 35:1551.

Ransom, B. H.

1904. An account of the Tapeworms of the Genus *Hymenolepis* Parasitic in Man, including reports of several new cases of the dwarf tapeworm (*H. nana*) in the United States. Bull. 18, Hyg. Lab., Washington, 138 pp.; 130 figs.

Weinland, D. F.

1858. Human Cestoides. An essay of the Tapeworms of Man. Cambridge, Mass.

Zschokke, Fr.

1888. Recherches sur la structure anatomique et histologique des cestodes. Mem. Inst. nat. Genève, 17.

EXPLANATION OF PLATES

All figures outlined with camera lucida and all represent specimens of *Hymenolepis diminuta*.

ABBREVIATIONS

<i>ci.</i>	cirrus	<i>s.</i>	sucker
<i>cp.</i>	cirrus pouch	<i>t.</i>	testis
<i>dc.</i>	dorsal excretory canal	<i>tec.</i>	transverse excretory canal
<i>gp.</i>	genital pore	<i>tm.</i>	transverse muscles
<i>im.</i>	inner longitudinal muscles	<i>ut.</i>	uterus
<i>ln.</i>	main lateral nerve	<i>vc.</i>	ventral excretory canal
<i>om.</i>	outer longitudinal muscles	<i>vd.</i>	vas deferens
<i>ov.</i>	ovary	<i>ve.</i>	vas efferens
<i>rm.</i>	muscular layer of rostellum	<i>vg.</i>	vagina
<i>ros.</i>	rostellum	<i>vs.</i>	seminal vesicle
<i>sr.</i>	seminal receptacle	<i>v.</i>	vitellarium

PLATE I

- Fig. 1. Scolex, neck, and first proglottides, showing the rostellum. $\times 61$.
 Fig. 2. Scolex and neck of a fourth specimen of *H. diminuta*. $\times 61$.
 Fig. 3. Proglottides showing four testes in one. Acid carmine. $\times 27$.
 Fig. 4. Specimen showing two testes in one proglottid and an unusual arrangement of three in another. Acid carmine. $\times 27$.
 Fig. 5. Some proglottides at one-fifth the length of the strobila from the scolex. They are greatly contracted in the longitudinal direction. Acid carmine. $\times 27$.
 Fig. 6. Longitudinal section of the long specimen at 20 cm. from the scolex, stained with alcoholic borax carmine. $\times 61$.

PLATE II

- Fig. 7. Unusual arrangement of testes. Acid carmine. $\times 27$.
 Fig. 8. A different arrangement of the four testes. $\times 27$.
 Fig. 9. Some proglottides of the long specimen at 20 cm. from the scolex, showing an irregular arrangement of the testes in one. Borax carmine. $\times 27$.
 Fig. 10. Cross-section of the long specimen at 20 cm. from the scolex stained with alcoholic borax carmine. $\times 61$.
 Fig. 11. Scolex, neck, and first proglottides of third specimen. $\times 61$.
 Fig. 12. Scolex of the same type as that of my long specimen, too deeply stained to show the rostellum. Toto mount. $\times 61$.

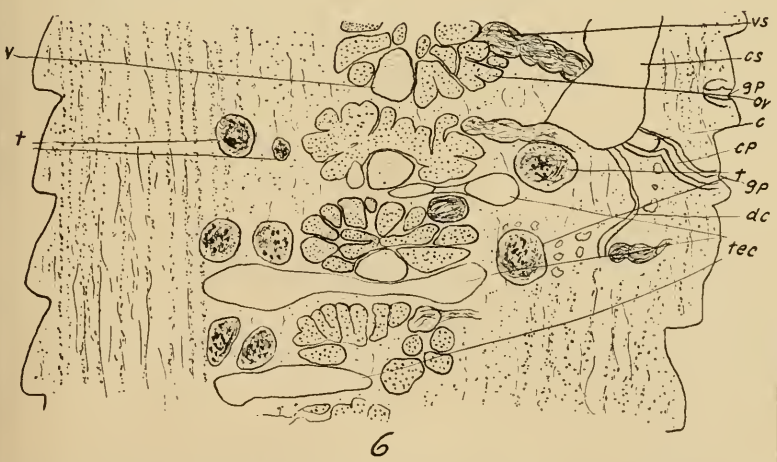
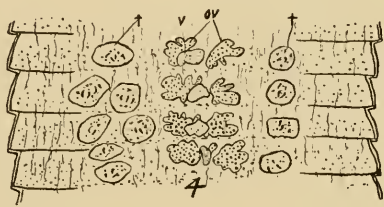
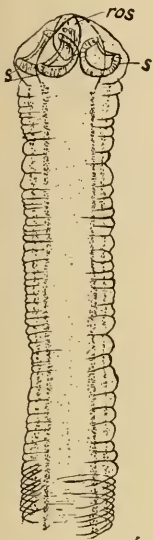



7

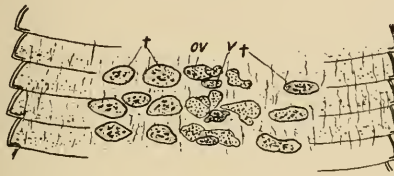

8

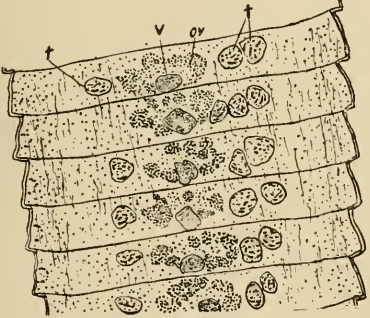

9

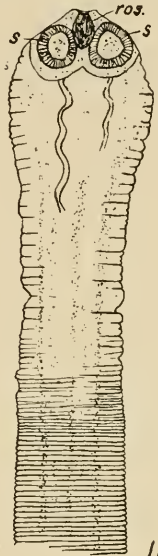

11.

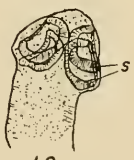

12.

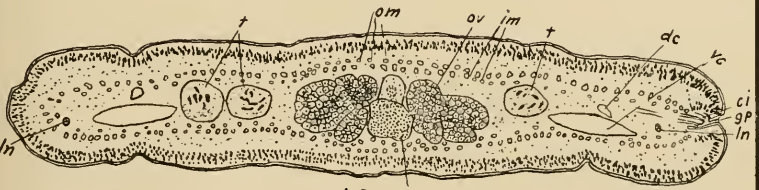

10

III.—*A Study of Some Gregarines with Especial Reference to*
*Hirmocystis rigida n. sp.*¹

BY MAURICE CROWTHER HALL.

A study of some of the gregarines found in the vicinity of Lincoln, Nebraska, was begun about the first of October, 1905. Gregarines were found in *Periplaneta americana*, in *Julus* sp., and in three genera of the Acridoidea, representing three sub-families, as follows: the Acridiinae, represented by *Melanoplus differentialis*, *M. femur-rubrum*, and *M. atlantis*; the Oedopodinae, represented by *Chimarocephalus viridifasciata* and *C. viridifasciata* var. *infusata*; and the Truxalinae, represented by *Eritettix* sp.

The gregarine from *Periplaneta* was found to be *Gregarina blattarum* Sieb. 1839; that from *Julus* is the form listed by Crawley as *Stenophora julipusilli* Leidy 1853; while those from the remaining forms are from new hosts and are apparently undescribed species. The old forms were studied in connection with the new to give a basis for morphological and physiological comparison, and require little special note aside from the record of their occurrence in this locality.

Gregarina blattarum was fairly common in *Periplaneta*, but for some reason was not found in *Blatta (Ectobia) germanica* from the same neighborhood. A single cyst ripened in water for thirty-six days with an air temperature of 18°C. was sectioned and showed the sporocysts with their nuclear content in various stages of development, a notable delay beyond the normal ripening period of less than a week given for this form by Bütschli (1881) and Magalhães (1900).

¹Studies from the Zoological Laboratory, The University of Nebraska, under the direction of Henry B. Ward, No. 77.

Remarkable conjugations are not uncommon in this gregarine, and in one instance I observed a case where the satellite occupied a deep concavity in the posterior part of the deutomerite of the primate. The satellite was of course very small, the primate being 400 μ long.

Stenophora julipusilli displays the characteristic movements attributed to it by Leidy (1851) and Crawley (1902-5), and to *S. juli* by Lühe (1904), constantly withdrawing the protomerite into the deutomerite, moving the protomerite from side to side, and assuming contorted positions from which it recovers with an elastic rebound.

Hirmocystis rigida n. sp.

An extensive and careful examination of *Melanoplus* during the fall of 1905 from October 1 to November 30 showed an infection with two species of gregarines, a yellow form, commonly in conjugates attached by the unlike extremities, and a larger solitary white form. The yellow gregarine I have designated as *Hirmocystis rigida* owing to the rigidity of its structure. Infection with this form was practically universal, about 200 specimens being found infected and only ten or fifteen not showing infection on casual inspection. Specimens of *Melanoplus* were obtained from the country around Lincoln and also from Scribner, eighty miles northwest of Lincoln. Gregarines were found in all localities investigated and usually in large numbers, as high as 400 to 500 in a single host.

A matter of especial importance in connection with this gregarine is the site of infection. In examining specimens of *Melanoplus* the method employed was that commonly used for this purpose, to cut off the head and the last two or three abdominal segments and then draw out the straight enteric tract with a pair of forceps. Gregarines could usually be found on the external surface of an intestine so treated, and often in large numbers. On one occasion I washed off about 300 gregarines that were in the body cavity and attached to or lying on the outside of the intestine. Other similar gregarines were usually visible on the inside of the intestine.

The only references I have been able to find regarding a similar occurrence of polycystid intestinal gregarines in the body cavity are as follows:

(1) Leidy (1851) writes, "*Gregarina achactae abbreviatae* . . . Habitation.—Proventriculus of *Achaeta abbreviata*. The same species I have observed in two instances on the exterior of the ventriculus, free within the abdominal cavity. . . .

"*Gregarina blattae orientalis*. Habitation.—Within the intestine and without, closely applied to its parieties, in *Blatta orientalis*."

(2) Magalhães (1900), in referring to his proposed *Gregarina serpentula* from *Periplaneta americana*, notes that he finds it "dans sa cavité viscerale, au niveau de l'origine des tubes de Malpighi."

I have found the same thing in *Gregarina blattarum* (Leidy's *G. blattae orientalis*) and in a gregarine from *Eritettix*, so I am inclined to regard the phenomenon as more common than the literature on gregarines would indicate. In *Melanoplus*, it is so common as to constitute the body cavity a secondary site of infection.

In the case mentioned where so many gregarines were found in the body cavity, I noted an incident which throws some light on the possible method of infection. In this case, the caeca, a common site of infection, were filled with gregarines, and while making a sketch of one of these, the tip of the caecum ruptured and the line of gregarines which had been packed in there with the protomerites pointing toward the tip rapidly made their way out. There were sixteen gregarines, of which twelve were in pairs. This at once suggests that the intestinal forms may at times force their way through the loose tissue at the tip of the caecum, and in fact this would seem to be the logical outcome of packing this organ full of gregarines. And inasmuch as gregarines of all sizes were found in the body cavity, it seems probable that an opening once formed is afterward used to a greater or less extent by other gregarines which may travel up the caecum.

Some idea of the extent of the infection may be drawn from the fact that on one occasion a single fecal discharge yielded 102 gregarines, perhaps a result of the partial sloughing of the intestine which Léger and Duboscq (1902) have studied in connection with the gregarines. What the effect on the host of such extensive parasitism with the accompanying rupture of the intestinal wall may be is uncertain, and as writers on this subject have pointed out, our knowledge of invertebrate pathology is too limited to judge this point. Rössler (1882), however, in his study of *Actinocephalus fissidens* and *Stylorhynchus caudatus*, parasitic in the Phalangidae, and Johansen (1894) regarding the new species, *Actinocephalus goronowitschi*, which he found often packed together in the caeca of *Phalangium opilio*, both state that these forms occur at times in such numbers as to cause the death of the host.

Hirmocystis rigida is a fair-sized gregarine, the typical specimen being about 700 μ long, of which the protomerite is about 185 μ and the deutomerite 615 μ . The size is, of course, variable, some specimens exceeding the total length given by 50 or 100 μ . The breadth of the deutomerite for the typical specimen is about 300 μ , the protomerite being slightly less than this.

Young specimens are clear, finely granular, and transparent. Later they become opaque and take on a color varying from sulphur-yellow to orange-red. It is commonly stated, as by Rolleston (1888) and Wasielewski (1896), that the color of gregarines is due to the nature of the intestinal content of the host, and the fact that practically all the gregarines of one locality were orange-red and those from other localities yellow would seem to indicate that the color follows directly from the food of the host, but the presence of a white gregarine of a different species in the same host with the yellow gregarines would seem to indicate that gregarines of a given species exercise a selective affinity for certain kinds of food material.

The sporont is notably polymorphic. This is not due to the constant flexion so common in such relatively soft-bodied forms as *Gregarina blattarum*, but to a more or less permanent variation in shape of the rigid body. The typical form has a subspherical

protomerite flattened at its union with the cylindrical deutomerite, the latter rounding off rather abruptly at the posterior end (fig. 8).

This gregarine is quite active, especially as regards locomotion. Gregarines lying motionless in the intestinal fluids on a slide, if brought into the light of the Abbé condenser, would remain quiet for a few moments and then glide away, displaying a pronounced negative heliotropism under what seemed an irritating stimulus. An interesting variation of this occurred when a young and transparent specimen was brought over the condenser and remained quiet; the entocyte, however, rapidly clouded up, finally becoming quite opaque. Gregarines would occasionally travel away from the body content, but usually turned back from the pure salt solution farther out, as though under chemotactic or physical stimulus.

A gregarine with the protomerite partly withdrawn into the deutomerite,—a condition common in *Stenophora julipusilli*, but rare in this gregarine,—was on one occasion observed traveling backwards against a diffusion current by a sort of jerking movement of the entire body. Jerking movements have been noted as occurring under certain circumstances by Crawley (1905), and in the same paper he notes a gregarine which even advances by leaps.

Change of shape, both by flexion and by symmetrical variations of body outline, is quite common, though the flexion is more deliberate than that of *Gregarina blattarum* and never carried to the same extent. In change of body outline I have seen specimens with a pronouncedly convex deutomerite outline gradually bring in the walls of the body until the outline was concave.

Although the shape of the gregarine is that previously stated, with the protomerite subglobular and body cylindrical, it should be said that when the animal is on a hard surface, such as a glass slide, the portion of the protomerite and deutomerite which is in contact with this surface flattens out, and specimens killed under such conditions will frequently retain the flattening, which can be seen as the gregarines float about in the fluid reagents. So far as I can judge, any part of the body surface will serve as a

ventral surface. Crawley (1902) has observed the gregarine rotating on its long axis. One would expect any part of the body to serve as the ventral when the animal is in the intestinal fluids of its host. Sections of the host intestine show that there is no flattening of the gregarines in it, contrary to the statements of Delage and Herouard (1896). Crawley (1902) has also criticised this opinion.

As a rule, no epimerite is present, even in very young forms. When it is present it occurs as a small papilla (figs. 17, 19).

In a rather odd form the protomerite and deutomerite were continuous externally and with only the septum, which in this case was convex anteriorly, to indicate the line of separation. Anterior to the protomerite, the sarcocyte curved forward and enclosed a small mass of entocyte. The epimerite of gregarines in general may be ectoplasmic or have an endoplasmic content beside, but the latter form in this specimen is probably aberrant. There is, of course, no reason to suppose that so-called "sports" may not occur among gregarines as elsewhere. The absence of an epimerite even in very small specimens is probably correlated with the very general early conjugation, as various writers, Lühe (1904) et al. have suggested.

While the shape of the protomerite is quite constant for larger specimens, there is considerable variation in the younger and smaller ones which are excessively polymorphic. This variation is largely due to variations of external outline so that the protomerite may be globular, hemispherical, subconical, short or long cylindrical, and at times be surrounded anteriorly by an indented circle (figs. 14-20).

Quite commonly specimens show a small indentation anteriorly, extending about half way through the sarcocyte (figs. 9, 11). Leidy (1851) describes a similar feature, and Crawley (1903) refers to Leidy's observations in his description of *Stenophora juli* as follows: "His figure 17 is especially good in showing the apparent orifice through the thickened epicyte of the anterior part of the protomerite."

In *Gregarina blattarum*, Marshall (1893) regards a similar structure as probably of use in conjugation. The fact that I find

it in primites seems to argue against this view. It occurs quite commonly in the reduced epimerite of this gregarine and hence is not of the same nature as the scarification commonly following the loss of more elaborate epimerites (*vide* Lühe 1904). It might perhaps serve this form, on occasion, as an aid in temporary attachment to the intestinal wall of its host, and in fact I have occasionally found small gregarines in contact with the intestinal wall, in sections, with the tip of the protomerite or epimerite.

The deutomerite, aside from flexion, is less variable in shape than the protomerite, but may vary from cylindrical to truncate conical and obovate, or, rarely, show a biconcave outline due to a shallow median annular depression medianally. Changes of shape due to flexion involve the deutomerite rather than the protomerite from the very nature of the case.

The epicyte in this gregarine is notably clear and distinct. The longitudinal striations first described by Leidy (1849) are very pronounced, more so than in *Gregarina blatterum* or *Stenophora juli*. These are especially clear after crushing the gregarine to remove the endoplasm (fig. 7), and I have even found them printed on a glass slide where a gregarine had been killed and had fallen off in mounting. Thin sections show that the epicyte has a set of fine parallel lamellae similar to those of *Lophocephalus insignis* and belonging in the general category of longitudinal ribbings possessed by most gregarines (fig. 7). These lamellae do not converge in curves at the posterior end of the deutomerite as Schewiakoff (1894) described them for *Gregarina (Clepsidrina) munieri* and Wasielewski (1896) has stated as a general truth, but converge instead at an acute angle (fig. 6).

The nature of the longitudinal striation commonly visible in gregarines has been the subject of much discussion since it was first noticed. Quite commonly it is referred to the longitudinal ribbings for its cause (Wasielewski, 1896). Lankester (1872) expressed the opinion that the striation might be in the cuticle, or in the cortical substance (sarcocyte) as permanent fibrillae, or on the inner surface of the cortex as temporary folds, and is inclined to regard the latter as the cause of the longitudinal striation. Bütschli (1882) regards the longitudinal striation as due to

the longitudinal cuticular ribbing and also to the folding of the ectosarc. Van Beneden (1872) regarded Leidy's longitudinal striation as accidental, and adopted the view of Lankester and Leuckart, that the striae originate in a folding of the cortical layer.

Observations on the gregarine from *Melanoplus* indicate that the longitudinal striation is due primarily to the cuticular ribbing, but does not correspond to it to the extent that the number of striae visible is identical with the number of ribbings on the surface under observation. The distance between the cuticular lamellae is fairly constant and very slight, about 0.5μ . On the other hand, the distance between the visible striae is very variable and much in excess of the figures given for that between lamellae, ranging from 2μ to 10μ . Magalhães (1900) similarly records those of *Gregarina blattarum* as 7μ apart. Moreover, the lamellae are continuous from end to end of the animal, whereas the striae are quite uniformly shorter than this and usually lap ends in the region of the septum. The striation which is due to the true cuticular lamellae arises from light rays striking these ridges at such an angle as to be refracted to the ocular where they become visible. In a young gregarine from *Eritettix* I have found that changing the position of the eyes would shift the striae from side to side. In dealing with a curved surface, such as the gregarine body, it would naturally be expected that the light refraction would be visible at intervals varying in different individuals and in different parts of the same individual, and that even these light areas would probably become discontinuous at intervals and especially at the ends of the body and in the neighborhood of the septum where a new factor of curvature is introduced.

Aside from the above, other factors enter in from the folding of the cuticle or the entire ectosarc, such as is shown in cross-section (fig. 1) and in the view of a specimen treated in toto with gold chloride (fig. 21). Such foldings complicate the light refraction of the cuticular lamellae and also add new striations to which the cuticular lamellae have a minimum of causal relation. It would naturally be expected that folding in a longitudinal plane would occur in a surface in which a set of relatively stiff longitudinal ribs already existed to give direction to the folding.

The sarcocyte is well developed and especially thick and distinct over the anterior part of the protomerite. In figure 11 the anterior sarcocyte is 23μ thick and the lateral 6μ . This thickening of the anterior portion of the protomerite is a common feature in gregarines and perhaps has a protective function, especially in forms with a host like *Melanoplus* where the food consists of grass, stubble, and other harsh substances through which the advancing gregarine must make its way. Cross-sections usually show the sarcocyte to be of uniform thickness for a given transverse plane, but at times one quadrant appears thicker than the others. This is probably due to body contraction. I have noticed a distinct thickening of the sarcocyte on the inner side of a curved gregarine from *Eritettix*; Crawley (1905) has made a related observation.

Thin cross-sections show circular fibers running through the sarcocyte, especially the inner half, and the same fibers are cut in cross-sections in gregarines sectioned longitudinally (figs. 1, 3, 5). Lankester (1872) notes that in *Monocystis sipunculi* the thickened anterior cortex has a set of fibers running longitudinally. He states that this anterior cortex is eminently mobile and regards the cortex as the seat of muscular activity. Léger and Duboscq (1902) write similarly regarding *Pteroccephalus nobilis*. The fibers in *Hirmocystis rigida* run circularly in the tip of the protomerite as elsewhere and are quite abundant (fig. 4). I have occasionally noticed a twisting of the protomerite striation, showing that the protomerite tip is capable of a slight rotation with reference to the part near the septum; this is more apt to be seen in forms where the rudimentary epimerite is present. Léger and Duboscq (1902) have noted in *Pyrrinia* occasional spiral striae instead of straight striae on the epimerite, "sans doute a la suite d'une torsion."

The seat of muscular activity has been variously located by different writers. Leidy (1851) thought he had found it in the longitudinal striations; v. Beneden (1872) located the first described set of transverse fibers in *Porospora gigantea* just under the cuticle, giving the coats in this order, a "central column, . . . cortical parenchyma, and a very thin subcuticular . . .

muscular coating." He notes that the muscular sheet "between the cuticle and cortical parenchym is inflected to constitute the transverse partition"; Lankester (1872), as previously noted, regarded the cortex as the seat of muscular activity; Bütschli (1882) regarded the ectoplasm as contractile and the myocyte as doubtfully so.

The common view of the myocyte is that stated by Crawley (1905), "a layer of fibrils," and contrary to the position in which it was found by v. Beneden (1872), it usually occurs on the border between the ectocyte and entocyte. In mounts of young specimens of *Hirmocystis rigida* I find between the sarcocyte and entocyte the row of dots which is classic as indicative of the myocyte fibrils in cross-section, but in mature specimens the myocyte appears to be represented by the fibers in the sarcocyte, while the border between the sarcocyte and entocyte has a structure which I have not seen specifically described elsewhere. This structure (fig. 2) shows near the septum in longitudinal sections as a row of dots or short lines in the protomerite and deutomerite, merging into a solid line, which forms the septum. In very young specimens the ectocyte, as such, seems to form the septum, which may take any position between the presentation of a strongly convex surface to the protomerite, and the reverse of this. Bütschli (1882) has noted that the septum may form from the cuticle itself in young gregarines, and this may be the case here. He also records v. Beneden's statement that in forms without a sarcocyte the cuticle may form the septum permanently. It is commonly held that the sarcocyte forms the septum and it is probable that here the inner sheet limiting the sarcocyte and occupying the usual position of the myocyte is merely a sarcocyte differentiation. It is also held, as Wasielewski (1896) states, that the myocyte "fehlt in Niveau des Septems," but in the gregarine from *Melanophus* I am inclined to regard the septum as of a contractile nature, since mere peripheral constrictions of the fibrous sarcocyte seem inadequate for the production of the elaborate symmetrical folding over a circular surface necessary to account for the forms shown (figs. 16-20). Still the explanation of this

may lie in the presence of circular concentric areas of varying rigidity in the septum.

In a mounted specimen I have seen what appear to be two distinct septa, and Bütschli (1882) records a similar observation. This again is probably a mutant.

The movements of gregarines have been the subject of considerable discussion. It seems fairly certain, as Crawley (1905) has observed, that since there is considerable variation in structure in different gregarines, a corresponding variation in the cause of movements may be expected, and it may be that the myocyte is contractile without being the only contractile element.

Probably the most noteworthy feature of gregarine movement is that of bodily progression or translation. This even, gliding motion, unaccompanied by any seeming adequate manifestations of energy, has called forth several theories of more or less prominence and likelihood. These theories are briefly as follows: (1) Lankester (1872) referred the movement of *Monocystis sipunculi* to an "undulation of their lateral margins"; (2) Plate (1886) thought that the gregarine took in part of the surrounding fluid at one point and diffused it out ventrally, the diffusion forcing the gregarine forward; (3) Frenzel (1891) regarded it as due to a chemotactic attraction between the gregarine and intestinal food masses, similar to molecular attraction or gravity; (4) Schewiakoff (1894) believed that movement was due to an extruded gelatinous thread which flowed posteriorly and, hardening, pushed the gregarine ahead; (5) Porter (1897) suggested that it was "probably caused by a very slight undulatory motion of the under side of the animal"; (6) Magalhães (1900) suggested the following, "Le mécanisme de cette locomotion . . . chez les Gregarines, je serais tenté de l'attribuer à une fonction propre, contractile, des fibres existant dans toute la longueur du corps de l'animal, fibres rendues bien apparentes et bien révélées par la striation régulière longitudinale du corps"; (7) Crawley (1902-5) attributes it to the action of the myonemes, though his first statement was not very clear.

Most of the theories quoted seem to me to have been adequately answered by writers on gregarines, and some of them are ob-

viously far afield. I believe Crawley has taken a logical position in relating progression to the probable cause,—muscular activity,—and his statement of the *modus operandi* appears to me as the most logical yet presented. In his second paper on this subject (1905) he states his case thus: "In the gregarine, the oscillation of the protomerite is the conspicuous manifestation of muscular activity, and under ordinary conditions of observations, the only one which is seen. But it is always accompanied by the wave on the surface of the deutomerite. The result is that a given point on the gregarine's surface pushes backward and transversely upon whatever may be in contact with it. This brings about a movement of the entire animal in an opposite direction. The movement will be rectilinear or zig-zag, dependent on the greater or less extent of the transverse movement."

The idea that I have arrived at in regard to gregarine progression accords with the above idea as I understand it. That the contractile element, presumably fibers of some sort, in any case, should be responsible for ordinary movement of any sort would seem highly probable. It seems equally probable that when a gregarine is progressing over a hard surface, the inner muscular impulse which brings about that progression should be transmitted to that surface at the point of contact; and one might reasonably expect to find some movement of the gregarine body over its contact surface. Since the gregarine commonly moves in a straight line with the peculiar gliding motion, unaccompanied by apparent muscular activity, which has called forth so much speculation and such remarkable theories, it is naturally to be expected that the actual movement by which the muscular activity within is converted into a forward movement would be very slight. And after all, this is quite in accord with another fact, namely, that gregarines move with exceeding slowness. Schewiakoff (1894) found that *Gregarina munieri*, the fastest gregarine he had under observation, traveled 1 mm. in three minutes, and I have noted an equal speed for *H. rigida*, while the white gregarine from *Melanoplus* would on occasion travel 1 mm. in one minute and fifty seconds. But when one stops to consider that *H. rigida* requires over seventy-five seconds to travel a dis-

tance equal to its own length, that *G. municri* or *H. rigida* require half an hour to travel 1 cm., and that the faster white gregarine can only make it in a little over eighteen minutes, it seems evident that one need not ask for violent muscular displays to explain this.

The method by which I believe muscular activity to be transmitted to a surface is practically stated in this sentence from Crawley (1905), "A given point on the gregarine's surface pushes backward and transversely upon whatever may be in contact with it." In other words, the gregarine "sculls" in the same manner that a skater does, converting the transverse impulses of the myocyte fibers into a rectilinear movement. And where the transverse impulse of the skater is resolved through two skate blades, the gregarine impulse is resolved through the surfaces of the numerous cuticular lamellae or ribbings; where the sharp skate blade cuts into the ice for its leverage, the cuticular ribbings get a leverage from the sticky substance which Schewiakoff (1894) regards as secreted by all gregarines (though some certainly lack not only a "Gallertschicht" but a sarcocyte as well), and Crawley regards it as at times secreted by the gregarine and in other cases derived from the broken-up host tissue.

In the case of the exceptional gregarine forms with a tuberculate cuticle some suitable modification of the sculling movement probably occurs. That the cuticular markings should be associated with progression is not at all remarkable. There are many things pointing to the ciliates as the ancestors of the gregarines (*vide* Calkins, 1901) and some reason to suppose that the cuticular markings are homologous to the cilia and perhaps derived from them.

The entocyte is regularly clear and transparent in young specimens and shows a fine to slightly coarse granulation. In older specimens it becomes opaque, a common thing in gregarines, owing to the storage of reserve food particles, and takes on a yellow color. Occasional specimens show yellow drops of varying size in a clear peripheral area where the oil reserve, normally distributed somewhat evenly, has broken up and permitted the oil to collect in drops. The larger granulations of the entocyte may

likewise be uniformly distributed or may collect in a peripheral hollow cylinder or a central solid cylinder or be irregularly distributed. Inclusions, at times globular and at times irregular, are occasionally present. They do not stain in the same way that the nucleus does.

The entocyte of the protomerite is commonly more finely granular than that of the deutomerite and often manifests a slight difference in its affinity for stains. This same difference in staining reaction has been noted by Léger and Duboseq (1904). Johansen (1894) records that in *Actinocephalus goronowitschi* the protomerite is uniformly granular, while the deutomerite is irregularly so with clear spots. These things naturally suggest some speculation in regard to the question which Lühe (1904) raises regarding the nutrition of gregarines. There is no reasonable question as to the nature of this nutrition and the method by which it is taken in by the gregarine, but whether the absorption from the intestinal content takes place uniformly over the entire body surface or preponderantly over a restricted area is not known. Bütschli (1882) notes the quite evident fact that substances pass in solution through the ectocyte and then precipitate out in the entocyte to form the reserve granules. Of the possible hypotheses in regard to the exact location of the osmotic action I think the facts in hand point to one as the more probable. The presence of a septum makes it quite natural to ask, Is osmosis about equal over the entire body surface, or does it predominate in the protomerite or deutomerite, the dominant member in the latter case supplying the other by osmosis through the septum? I am inclined to think that the method of feeding in infusoria, where a thin place in the ectosarc is utilized for the ingestion of food, gives a basis for believing that osmosis would occur most readily where the ectosarc was thinnest. Consequently, in forms where there is a thickening of the sarcocyte over the greater part of the protomerite and the posterior part of the deutomerite, as in *Hirmocystis rigida*, it seems probable that osmotic imbibition from the exterior is most active in the deutomerite between the septum and the posterior thickening. This seems to fit very well with the finer granulation of the entocyte in the protomerite, a

phenomenon readily explicable on the ground that food substances are imbibed in this region, the coarser granulations precipitating in the deutomerite and the part with the finer material in solution transfusing through the septum to the protomerite to be precipitated in this region as a finer granulation. Between forms with anterior and posterior thickenings and those with a thin, more or less uniform ectocyte it is likely that there is a corresponding variation as to the extent and location of absorption. In *Stenophora julipusilli* I find a nearly uniform ectocyte and a correspondingly uniform granulation.

In the case of a transparent gregarine clouding up on being brought over the Abbé condenser light, I was unable to detect any contraction of the body which might have accounted for the opaque condition. It is just possible that light may influence the physical condition of cytoplasm used to darkness and influence it sufficiently to be observed.

In young specimens the nucleus shows readily as a clear glassy sphere lying in the entocyte and surrounded by a clear fluid. In some nuclei, the so-called nucleoli are readily visible. In full-grown specimens the nucleus may be faintly indicated in the entocyte or wholly obscured. Sections of mature gregarines show the nuclear structure which Grüber (1884) gives for gregarines in general: a vesicular build, a membrane enclosing a clear nuclear fluid with the contained nucleoli. The nucleoli are very numerous and arranged in involved loops.

Delage and Herouard (1896) give the position of the nucleus as slightly below the middle line of the deutomerite. While this is the common position it may occur anywhere from near the region of the septum to the extreme posterior portion of the deutomerite and either centrally or peripherally within the limits of the entocyte, a fact indicative of the loose structure of the entoplasm. Rolleston (1888) also notes the shifting of the nucleus. Lühe (1904) has noted that the nucleus may occur abnormally in the protomerite. It can be readily forced out of the body under pressure and found intact in the extruded body content.

This gregarine occurs typically in pairs of "head to tail" conjugates, the conjugates ranging from very small to those of full-

grown gregarines. Quite commonly the satellite is smaller than the primitive, but I have never found the reverse true. Lines of individuals may be readily resolved into the separate pairs of conjugates.

I occasionally find a gregarine in which the protomerite shows an anterior peripheral circlet. On breaking up a recently formed conjugation I have found that the protomerite of the satellite showed the same thing, indicating that the circlet in gregarines is probably due to the breaking up of a conjugation. Bütschli (1882) refers a similar observation to the same cause. Whether conjugations are broken up in nature or are broken in teasing the host intestine is not certain. In a solidly-formed conjugation the protomerite of the satellite undergoes a great reduction and at times shows only as a thickened band (fig. 7).

An interesting thing is the fact that often there is seen in a newly-formed conjugation a highly colored orange or orange-red spot at the point of contact either in the deutomerite of the primitive or the protomerite of the satellite. This may be an indication of a substance of assistance in forming the fusion.

Cysts may be obtained from the intestine or the caeca or from the feces. In encystment gregarine conjugates bend at the point of contact, as Bütschli (1881) first noted, so that the two come to lie side by side, the protomerite of one opposite the end of the deutomerite of the other and in contact with it. The surfaces in contact flatten out, the conjugation assuming a shape varying from spherical to a much elongated oblate-spheroidal, of which each individual forms a symmetrical half. I have not observed the rotation during cyst formation noted by Bütschli (1881) and Crawley (1905). Conjugations of individuals of different size, so far as I have observed, do not show as solid, final affairs as do those where the individuals are of approximately equal size, and I am inclined to think with Marshall (1893) that they do not lead to successful encystment, at least while the size remains different.

That conjugations, where the individuals are both small or both large, may successfully encyst is shown by the variation in size of the resultant cysts. The cyst usually shows outside the limit-

ing zone of the gregarines proper a clear refractive area, sharply defined, and outside of this a broad, gelatinous zone. The absolute and relative dimensions of these coatings vary greatly; the inner coat may appear to be lacking or occasionally a cyst is without any coating. Bütschli (1882) has noted the same occasional lack of outer membranes. They are perhaps developed and subsequently lost.

Cyst envelopes are quite commonly regarded as secondary or derived structures, which they obviously are, as there is nothing in the normal gregarine comparable with the thick gelatinous cyst covers. Presumably these originate in a condensation of the body-mass of the gregarine and the consequent secretion of the hygroscopic material making up the cyst coverings. As might be expected from their mode of origin, these coverings show a concentric and radial striation, the former being the more apparent in toto observations. Sections often show an apparent vacuolization of the cyst coverings where circular areas fail for some reason to take a haemotoxylin stain.

Some cyst dimensions are as follows:

Diameter without envelopes	552 μ	envelope thickness	1828 μ
Diameter without envelopes	368 μ	envelope thickness	110 μ
Diameter without envelopes	460 μ	envelope thickness	230 μ
Diameter without envelopes	166 μ	envelope thickness	46 μ
Diameter without envelopes	240 μ	envelope thickness	26 μ

The average diameter is 300–400 μ ; thickness of envelopes when present 50–75 μ .

The cysts are usually yellow, rarely orange-red, the color following directly from that of the component conjugates. On one occasion four dark yellow cysts were found embedded in a slightly yellow gelatinous mass, perhaps the result of conjugations encysting in approximation. About the edge of the mucilaginous mass were about fifty small gregarines; Magalhães (1900) has a somewhat similar observation.

On crushing some cysts, the contents appear rather granular and not notably different from the usual entocyte; in others the cyst content shows under high magnification many small bodies,

of which the smaller, clavate forms are in active motion and the larger oval forms are stationary. My observations were not sufficiently followed up to determine whether these were reserve granules of the entocyte with the smaller displaying the Brownian movement, or whether I had under observation a phase of sexual multiplication such as the work of Léger (1901-4) has led us to expect in gregarines.

Cysts ripened for varying periods in water usually take on a pink to red color. Occasionally tubercles appear on the surface, due, as sections show, to the formation of large vacuolated areas in the peripheral plasm of the cyst. I was unable to provoke spontaneous dehiscence of the cysts by ripening in water, though my most extended observation on this point covered cysts that had ripened dry for sixty days and then been left in water for forty-seven days. After being left dry for twenty-seven more days, one cyst out of five was full of uniformly developed sporocysts, as determined by sectioning. Of seven cysts which had ripened dry for 208 days, three showed the sporocysts on sectioning, though the cyst had refused to open in water. Two other cysts opened. These latter cysts showed a light yellow color with a dry, shiny, slightly roughened surface and no cyst membranes. On the addition of water, a mucilaginous cyst membrane started to form, and inside of a minute had increased to a thickness equal to the cyst diameter. Simultaneously an air-bubble formed at one point on the cyst, followed by an eruption of a coherent mass of white material together with numerous other air bubbles. Sections of these cysts showed no spore formation, the cyst content being slightly granular and staining uniformly with iron haematoxylin.

In the expectation of dehiscence, I allowed the cysts to ripen some time without sectioning. The earliest sporocyst formation that I observed was after a period of ninety-six days, in one case in a cyst ripened dry and in another in a cyst that had been in water the last four days out of the ninety-six.

In a set of fifty-two cyst sections, covering a ripening period of from 80 to 208 days, eleven are achromatic at a period when it certainly indicates degeneration, three have a persistent septum

with signs of degeneration, and eight, while showing the chromatin, have the cytoplasm so broken up that degeneration is evident. Allowing for two duplicates in this list, the total number of degenerates is twenty, a percentage of almost 39; eleven showed the sporocysts, so that 21 per cent certainly ripened. The remaining 40 per cent showed the chromatin in such normal appearing cysts that it seems probable that the ripening process was going on, though slowly. The ripening was in a room with a temperature of about 18°C.

The time required for ripening here is unusually long. Bütschli (1881) found cysts of *Gregarina blattarum* ripening at summer temperature in about five days; Magalhães (1900) found the same form requiring from four days to a week; Wasielewski (1896) gives fourteen days as a common ripening period and states that some need over a month; Crawley (1905) finds that ripening occurs in periods varying in different forms from one to thirty days. It is probable that gregarine cysts from the fall species of *Melanoplus* ripen very slowly at the low temperatures of winter, perhaps not completing the process before the return of *M. junensis*, the probable spring host. This would make the winter ripening period something like five or six months.

Sections show that the sarcocyte has degenerated or condensed. Its constituent parts may take some part in the formation of the cyst covers. In recently formed cysts the partition between the two individuals separates readily along its opposed surfaces under the impact of the microtome knife, but in older cysts the partition shows a distinct lenticular thickening in the middle. The line of separation between the two individuals usually persists externally for a long time.

Chromatin occurs diffused or as the foci of a network, as Marshall (1893) found it in *Gregarina blattarum*, for most sections. Three sections show clean-cut nucleoli. In one of these, a cyst ripened dry for fifty-five days and in water for twenty-five, no partition is present, the single nucleus is somewhat "flamed" and contains the nucleoli. This is evidently an encystment of an individual gregarine. In another case the partition separates two vacuolated areas, one clear and the other granular. The nuclei.

which stain pink with Heidenhain's haemotoxylin, are in two or three local areas and in the granular area or its border. There is a suggestion of individual gregarine encystment here, the clear area being perhaps the protomerite and the partition the septum. The third section shows the cyst content to be vacuolated, the nuclei occurring in local peripheral areas and along the region of the degenerating partition.

Vacuolization of the cyst content occurs in 13 per cent of the cysts. Besides these 19 per cent show the spores or chromatin arranged in a crescentic outline, the tips of the crescent enclosing a space that may be empty or have a slight, apparently degenerate content. This may be a modification of the vacuolization, and as it occurs in yellow as well as white cysts, of which I find a few, it seems to be a mere incidental feature of the cyst ripening of *Hirmocystis rigida*.

An interesting case is that of a cyst which was ripened for 141 days and on sectioning showed two gregarines intact with the septa of both individuals complete. No nucleus was present in either, and the body content of both stained evenly.

The spores are oval, about $5\ \mu$ long and $2.5\ \mu$ in diameter. The chromatin first shows as a thick central cylinder, later aggregated as two dense spheres at the poles and then as four short parallel rods at each end of the sporocyst, the long axis of the rods parallel to the long axis of the spore. Six cysts ripened up to a period of 153 days show the spores to be fairly uniform as regards chromatin and development. Four out of five cysts ripened over this time show a few sporocysts with a dense chromatin content and many that appear to have no chromatin. This may indicate sporocyst degeneration. My failure to get the cysts to dehisce has prevented any observations on the sporozoites.

The cyst structure with its relatively thin walls enclosing a solid mass of spores shows that no sporoducts are present and that dehiscence is by simple rupture.

The characters of the gregarine may be briefly stated as follows: epimerite,—very small, regular and simple, is reduced to level of protomerite in early growth; gregarines commonly in association and with septum in primite and satellite; cysts,—de-

hiscing by rupture of the wall; sporulation,—complete to partly complete; sporocysts,—oval. These characters place the gregarine from *Melanoplus* in the family Gregarinidae. Further than this the gregarine does not seem to be exactly conformable, but since it comes nearest to the genus *Hirmocystis*, it may be placed in that genus for the present at least.

The most careful search for an intracellular stage of this gregarine shows nothing that can be called such. There are numerous cellular inclusions, but these are undoubtedly the hyaline and chromatin waste and degeneration products which have been so well studied by Léger and Duboscq (1902-4) and which for years had deceived such workers as Bütschli, Aimé Schneider et al.

The measurements of some of the gregarines which I find free in the intestines and caeca are as follows, 103 μ , 120 μ , 91 μ , and 73 μ . So that the gregarine 73 μ long is not intracellular, though the intestinal cells of the host range from 80 μ to 170 μ in height and might readily hold a gregarine of that length. To determine the nature of the sporozoite development and its relation to the intestinal epithelium will probably require some artificial infection experiments.

The gregarines from *Chimarocephalus* and *Eritettix* have not yet been studied sufficiently to permit of a satisfactory description at this time though the writer hopes to complete a study of these forms in the near future. Figure 12 shows a view of a permanent mount of the gregarine from *Chimarocephalus*. It will be noticed that the nucleoli are visible in loops, as Wasielewski (1896) gives for *Lophocephalus insignis*.

Search was made for *Hirmocystis rigida* in the vicinity of Colorado Springs, Colorado, and at St. Peters, about fifteen miles from Colorado Springs, but of the numerous specimens of *Melanoplus* that were examined none were infected. At Canon City, Colorado, the infection was extensive, at least half of the specimens of *Melanoplus* being infected with from two or three to several hundred parasites. The common species of *Melanoplus* at Canon City are *bivittatus*, *differentialis*, and *angustipennis*. In these locusts the gregarines were never found outside of the intestine in the body cavity, but were sometimes on the outside of

the intestinal content and next to the intestinal wall, occasionally showing as yellow patches. All the hosts were from the same field, and of the parasites found a small number were orange-colored.

At St. Peters a mountain cricket showed an occasional slight infection with a white gregarine, but no study was made of this form.

The author's thanks are due to Dr. Henry B. Ward of the University of Nebraska for the suggestion of a line of work which is so full of interest and for the discipline and training which have accompanied the work under him. Thanks are also due to Prof. Lawrence Bruner of the University for aid in identifying the insect hosts of parasites.

BIBLIOGRAPHY

van Beneden, Ed.

1872. Remarks on the Structure of the Gregarines. *Quar. Jour. Mic. Sci.*, n. s., 12:211-18; 1 pl.

Bütschli, O.

1881. Kleine Beiträge zur Kenntnis der Gregarinen. *Zeit. f. wiss. Zool.*, 35:384-409; 2 pl.
 1882. Protozoa. Bronn's Klassen und Ordnen des Tierreichs, 1:479-589.

Calkins, Gary N.

1901. The Protozoa. *Columbia Univ. Biol. Ser.*, vol. 6, New York.

Doflein, F.

1901. Die Protozoen als Parasiten und Krankheitserreger nach biologischen Gesichtspunkten dargestellt. *Jena*, pp. 160-75, figs. 118-36.

Crawley, Howard.

1902. The Progressive Movements of Gregarines. Proc. Acad. Nat. Sci., Phila., 54:4-20; 1 pl.
1903. List of the Polycystid Gregarines of the United States. Proc. Acad. Nat. Sci., Phila., 55:41-58.
1905. The Movements of Gregarines. Proc. Acad. Nat. Sci., Phila., 57:89-99.

Delage, Yves et Herouard, Ed.

1896. Traité de Zoologie concrète. I. La cellule et les Protozoaires. Paris.

Frenzel, Joh.

1891. Über die primitiven Ortsbewegungen der Organismen. Biol. Zentralb., 11:464-74.

Grüber, Aug.

1884. Über Kern und Kernteilung bei den Protozoen. - Zeit. f. wiss. Zool., 40:136-37.

Johansen, Herm.

1894. *Actinocephalus goronowitschi*, eine anschienend neue Gregarinenform. Zool. Anz., 17:140-45, 4 figs.

Lankester, E. Ray.

1872. Remarks on the Structure of the Gregarinae and on the Development of *Gregarina (Monocystis) Sipunculi* Köll. Quar. Jour. Mic. Sci., n. s., 12:342-51; 1 pl.

Léger, Louis.

1901. Sur la morphologie des elements sexuels chez les Gregarines Stylohrynchides. Compt. Rend. Acad. Sci., Paris, 23:1431-33, 4 figs.
1904. La reproduction sexuée chez les Stylohrynchus. Arch. f. Protist., 3:303-57; 2 pl., 8 text figs.

Léger, L. et Duboscq, O.

1902. Les Gregarines et l'épithélium intestinal chez les Tracheates. *Arch. de Parasitol.*, 6:377-473; 5 pl., 18 text figs.
1904. Nouvelles recherches sur les Gregarines et l'épithélium intestinal des Tracheates. *Arch. f. Protist.*, 4:335-83; 2 pl., 11 text figs.

Leidy, Jos.

1849. Observations on Gregarina, Dufour, with description of a new species. *Proc. Acad. Nat. Sci., Phila.*, 4:226-33.
1851. On the Organization of the Genus Gregarina of Dufour. *Trans. Amer. Philos. Soc., n. s.*, 10:233-40.

Lühe, M.

1904. Bau und Entwicklung der Gregarinen. I. Theil: Die Sporozoiten, die Wachstumsperiode und die ausgebildeten Gregarinen. *Arch. f. Protist.*, 4:89-198.

Magalhães, P. S.

1900. Notes d'helminthologie brésilienne. Matériaux pour servir à l'histoire de la *Periplaneta americana* Fabricius. *Arch. d. Parasitol.*, 3:38-45; 4 figs.

Marshall, Wm. S.

1893. Beiträge zur Kenntniss der Gregarinen. *Arch. f. Naturg.*, Jahrg. 59, 1:25-44; 1 pl.

Plate, L.

1886. Untersuchungen einiger an den Kiemenblättern des *Gammarus pulex* lebenden Ektoparasiten. *Zeit. f. wiss. Zool.*, 43:235-38.

Porter, J. F.

1897. Two New Gregarinida. *Jour. Morph.*, 14:1-20; 3 pl.

Rolleston, Geo. and Jackson, W. H.

1888. *Forms of Animal Life*. Oxford; pp. 857-65.

Rössler, Rich.

1882. Beiträge zur Anatomie der Phalangiden. Appendix.
Über zwei neue Gregarinenformen. *Zeit. f. wiss. Zool.*,
36:700; 1 pl., 2 figs.

Schewiakoff, W.

1894. Über die Ursache der fortschreitenden Bewegung der
Gregarinen. *Zeit. f. wiss. Zool.*, 58:340-54; 2 pl.

von Wasielewski.

1896. *Sporozoenkunde*. Jena, 162 pp., III text figs.

EXPLANATION OF PLATE

FIGS. 1-6. VIEWS OF SECTIONS OF GREGARINES

Fig. 1. Cross-section of *Hirmocystis rigida* showing external folding of the sarcocyte and the fibers in the sarcocyte. $\times 500$. Section 3μ thick.

Fig. 2. Longitudinal section of *H. rigida* in the region of the septum, showing the formation of the septum. $\times 1600$. Section 3μ thick.

Fig. 3. Longitudinal section of *H. rigida* showing the fibers of the sarcocyte cut in cross-section. $\times 1600$. Section 2μ thick.

Fig. 4. Longitudinal section through the protomerite of *H. rigida* showing the fibers of the sarcocyte. Highly magnified. Section 2μ thick.

Fig. 5. Cross-section of *H. rigida*, showing the cuticular lamellae and the fibers of the sarcocyte. Highly magnified. Section 1μ thick.

Fig. 6. View of the cuticular lamellae at the posterior end of the deutomerite of *H. rigida*. Highly magnified. Section 2μ thick.

FIGS. 7-21. VIEWS OF TOTO MOUNTS.

Fig. 7. Conjugates of *H. rigida* crushed and stained with saffranin to show longitudinal striation. $\times 133$.

Fig. 8. Type specimen of *H. rigida*. $\times 105$.

Fig. 9. View of young gregarine showing median depression in epimerite. $\times 500$.

Fig. 10. View of young gregarine showing reduced epimerite. Highly magnified.

Fig. 11. Protomerite of *H. rigida* showing anterior thickening of the sarcocyte and its median depression. $\times 165$.

Fig. 12. Gregarine conjugation from *Chimaroccephalus viridifasciata*. $\times 110$.

Fig. 13. Solitary white gregarine from *Melanoplus*. $\times 113$.

Figs. 14-20. Views showing variations of septum and protomerite in young gregarines. Highly magnified.

Fig. 21. *H. rigida* impregnated with gold to show folding of sarcocyte. $\times 113$.

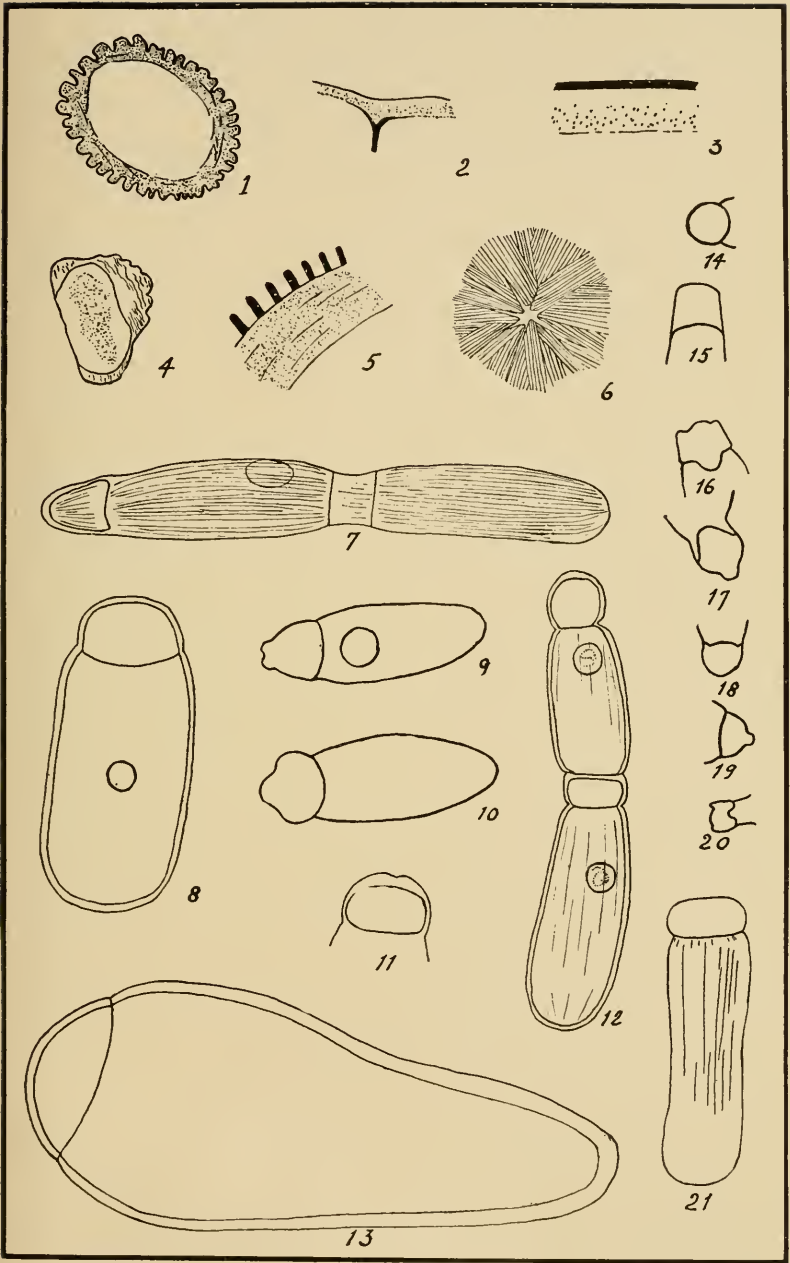

IV.—*On the Relation of Muscle Sense to Pressure Sense*

BY T. L. BOLTON AND DONNA L. WITHEY

In the following pages are reported the results of some experiments instituted with the purpose of studying more critically than yet has been done the relations between muscle sense and pressure sense, and furthermore of examining, incidentally at least, both the physiological and psychological processes of perceiving weight in general and the factors involved in discriminating differences between two weights. Various aspects of the perception of weight and of the discriminative process have been most carefully studied by Müller and Shuman,¹ Martin and Müller² and others, but so far as we are able to find there has been no study of the particular way in which muscle sense affects discriminations by pressure, and no one has pointed out the physiological processes involved in the perception of a weight and in the process of discriminating one weight from another.

How, then, do free lifting movements and the participation of muscular reactions affect pressure discriminations of weight? The difference threshold for pressure discriminations of weight as determined by E. H. Weber, based upon a given probability of correct judgments, and since confirmed by Fechner and others, is about one-third of the stimulus; and the same threshold for weights lifted with free arm movements has been variously stated as one-tenth to one-fortieth. The ratio of 15:16 for just observably different weights by the free or natural mode of lifting

¹Müller and Schuman. *Über die Psychologischen Grundlagen der Vergleichung gehobenen gewichte*, Pflüger's Archiv. f. d. ges. Physiologie, 1889, Band 45, S. 37 ff.

²Martin und Müller. *Zur Analyse der Unterscherds Empfindlichkeit*. Leipzig, 1899. See also E. A. Hayden, *Memory for Lifted Weights*. Amer. Jour. Psych., vol. 17, pp. 495-521.

would probably be about the average for all observers. It depends very much upon the method and purposes of the experiments what threshold is got. The chief difficulty in discriminating weight by pressure sense alone is to exclude muscular reactions and so make the discrimination depend solely upon pressure sense. The problem has not been solved with complete satisfaction. Professor Jastrow's¹ apparatus, which is a small scale so arranged that when weights are laid upon the scale pan the end of the scale beam presses the tip of the forefinger from below, is probably the best, and yet it is not entirely satisfactory. One can not be sure that the finger does not react downward against the scale beam. When weights are lifted pressure is always present in one form or another, so that in practice, even under experimental conditions, these two senses are not separate or fully separable. The distinction between pressure sense and muscle sense is, then, one of theory rather than of fact. The first problem set for us was to show how pressure discriminations of weight were affected by different amounts of participation of muscular reactions in the act of discrimination.

For this purpose a form of pressure balance, new in some respects, was constructed. The points held in mind in planning the balance were first to apply the pressure to the palm of the hand, second to permit the hand to rest in the most comfortable position and to fix it so as to shut out as far as possible muscular reactions, third to permit of different degrees of hand reaction against the pressure stimulus and to make the application of the pressure to exactly the same area of the palm, fourth to attain rapidity in the exchange of weights for different pressures, and to avoid the use of so many weights.

The arm is laid upon a table with the palm, thumb upward, against two upright pieces two inches apart set into a base board that rests upon the table. Against the back of the hand a support is brought which can be adjusted to any prismatic form as well as to any thickness of the hand. The balance consists of two

¹*Amer. Jour. Psych.*, vol. III, p. 54 ff. See also Sanford, *Experimental Psychology*, pp. 417-18.

strips of oak 600 and 300 mm. in length, 50 mm. wide, and 15 mm. thick. These are set together at right angles to one another, forming a cross. At their intersection a rod, three inches long and drawn down to a point at either end, is passed through the oak strips. This forms the pivot of the balance and is supported at either end by conical depressions in set screws, and these screws rest upon the tops of the two vertical pieces spoken of before. The longer oak strip swings horizontally and the other hangs vertically. The lower end of the later strip swinging between the uprights bears a cork which is brought into contact with the palm when the balance tips in one direction. The scale beam on the opposite side to the cork is graduated to five millimeter divisions and so adjusted that when a 200-milligram weight is laid upon the outer end it turns easily and decidedly. In operation a lead weight weighing 165 grams was set upon the scale beam at different graduations to give different pressures through the cork upon the palm. This weight was cast with a flat end and a sharp edge so that it might be readily and accurately adjusted to different graduations. The balance was operated by an eccentric cam by which the pressure might be brought upon the palm gradually and as gradually removed. In the experiments the standard weight chosen was the pressure exerted upon the palm when the weight was placed at 150 millimeters from the pivot of the balance. As this was about the same distance as the cork from the pivot the pressure was about equal to 165 grams. With care the weight can be readily adjusted to any graduation upon the balance beam within a half millimeter, so that the error arising from this source can not exceed at the outside .3 of one per cent of the standard used in these experiments.

The experiment began with an attempt to find the threshold for passive pressure upon the palm. Here the hand was firmly clamped in the position described above so as to shut out as far as possible all muscular reactions. It is not possible to prevent all contractions. In fact, when the hand is clamped in whatever manner one soon feels twitchings and tensions begin first in one locality and then in another; these grow more and more intense until a kind of cramp ensues, which is most painful. Care was

always taken not to press the hand too closely, and the reagent was urged to indicate any discomfort that might arise from overpressure or too long continuance of the experiment. Even where the hand is not confined, and small pressure is exerted upon any skin area, there is an almost irresistible tendency for reflex muscular contractions to begin. This relation of muscular contraction to stimulation is important and fundamental and will receive consideration later. Sometimes the hand was padded with view to equalizing the pressure over the back, but it was not done all the time and finally discontinued as it seemed to be of no especial advantage; the hand appeared to be no more comfortable and it was no aid to clear discrimination. In fact, it seemed at times to be disturbing or distracting, from the fact the padding always gave way under the pressure and this drew the attention from the contact on the palm and made the discrimination depend upon different degrees of recession upon the part of the padding.

The method employed was a modified form of the gradation method or the method of minimal change. The standard pressure was that represented by a weight of 165 grams set at a distance of 150 mm. from the pivot of the balance. As the stimulus magnitudes were always proportional to the distances the weight was set from the pivot, the actual weight can be dispensed with and the stimulus magnitudes represented by the graduations upon the scale beam. They were then 150 (standard), 170, 190, 210, 230, and 250. The procedure was to present these magnitudes in pairs, the standard and a compared weight in close succession. The standard came first in all cases. The compared weights were presented, each with the standard, generally in the order here given or in the reverse order. Variations were sometimes introduced to guard against the reagent taking cue, and to break up as far as possible the expectation of a difference or a no-difference, and hence avoid a declaration of a difference or a no-difference when none was really felt. Expectation is bound to enter and exercise some influence upon judgments even after the reagent should have become habituated to the mode of conducting the experiment and so looking upon it with entire indifference as to the outcome.

Observations were taken upon two experienced reagents who knew the apparatus and its mode of operation and upon thirteen naïve students who were quite unaware of what was expected of them. They were required only to say whether the two weights presented in close succession were the "same" or whether the second was "heavier" than the first. The answers of the experienced reagents might be "same," "doubtfully same," "doubtfully heavier," and "heavier." In practice the doubtful judgments were very few, and it will be seen that they have been of no particular significance for the results. The results are presented as so many series. A series consists of the judgments upon six pairs of stimulus magnitudes taken either in the ascending direction from the standard to the heaviest weight or in the reverse order from the heaviest to the standard. From four to eight series, usually four series, were taken at a sitting, and the experiments were made four or five times a week for more than two months. As our purpose did not include an accurate determination of the threshold or a study of the various influences that might affect the run of the judgments themselves, we have thought it worth while to conduct the experiments without view to eliminating the effects of space and time location which have been so carefully examined by Müller¹ and Schuman and Martin and Müller. As a matter of fact, the apparatus eliminates the errors that might arise from differences in space location, since the arm always occupies the same position and the weights are brought to it. Our purpose was rather to find a threshold by a given method and then to study the effects of muscular contractions upon the threshold determined by the same method.

The first set of experiments will be known as passive palm pressure. The second set of experiments was instituted shortly after the first began, and from that time forth sittings under the second were made to alternate with sittings under the first set. In this set the support back of the hand was slid back and the hand allowed freedom to react against the pressing cork. When the cork was brought into contact with the hand the reagent was required

¹Loc. cit.

to press the hand forward against the cork; this was done by straightening out the hand. The scale beam bearing the weight was then raised and lowered. The amount of movement allowed the hand was from one-half to three-quarters of an inch. This will be known as the palm pressure with hand reaction. After taking thirty-six series of observations, it was thought the steps between the stimulus magnitudes were too large for the hand reaction, and accordingly they were reduced from twenty to ten. The series in the second set of palm pressure with hand reaction presented the stimulus magnitudes represented by 150, 160, 170, 180, 190, 200, and 210.

In the third set of experiments the support for the back of the hand was taken away entirely and the pressure was allowed to rest against the tip of the third finger. The finger and arm were then made to react against the cork, raising the scale beam up and down. This set will be known as finger pressure with arm reaction. Observations were not taken upon the naïve reagents in this set. Again, the steps between the successive stimulus magnitudes were reduced and so were represented by 150, 155, 160, 165, 170, 180, and 190.

In the following tables are presented the results of each set of experiments:

TABLE I. PASSIVE PALM PRESSURE

S. M. means stimulus magnitudes. To the right of each stimulus magnitude the designations S. means "same," D. S. means "doubtfully same," D. H. means "doubtfully heavier," and H. means "heavier." The figures represent the actual number of judgments rendered. The number of series for reagent W. was 36 and for reagent B. 41.

REAGENT W.					REAGENT B.			
S. M.	S.	D. S.	D. H.	H.	S.	D. S.	D. H.	H.
150	27	1	5	3	33	3	3	1
170	22	1	4	8	21	4	4	8
190	16	0	7	13	15	3	3	20
210	5	1	3	27	5	1	4	31
230	3	0	2	31	4	0	1	36
250	2	0	1	33	2	0	1	38

By placing D. S. judgments with S. judgments and D. H. judgments with H. judgments, and adding 91 series for 13 naïve reagents, the following table is made. Percentages of S. judgments of the whole number of judgments are added:

REAGENT W.				REAGENT B.			13 NAIVE REAGENTS		
S. M.	S.	H.	%	S.	H.	%	S.	H.	%
150	28	8	77.7	36	8	87.8	73	18	80.5
170	23	13	63.8	25	16	61.0	53	38	58.0
190	16	20	44.2	18	23	44.0	34	57	37.0
210	6	30	16.6	6	35	14.5	14	77	15.0
230	3	33	8.0	4	37	9.5	7	84	7.5
250	2	34	5.0	2	39	4.5	1	90	1.0

TABLE II. *First Part.* PALM PRESSURE WITH HAND REACTION

The terms in this table mean the same as in table I. The number of series for reagent W. was 36 and for reagent B. 31. Eight naïve reagents took 42 series. Their judgments were either "same" or "heavier."

REAGENT W.					REAGENT B			
S. M.	S.	D. S.	D. H.	H.	S.	D. S.	D. H.	H.
150	31	2	2	1	24	2	2	3
170	17	1	13	5	11	4	3	13
190	3	7	6	20	4	1	1	25
210	0	2	2	32	0	0	2	29
230	0	0	0	36	0	0	1	30
250	0	0	0	36	0	0	0	31

By placing D. S. judgments with S. judgments and D. H. judgments with H. judgments and adding the percentages of S. judgments to the number of series, the following table is obtained:

REAGENT W.				REAGENT B.			NAIVE REAGENTS		
S. M.	S.	H.	%	S.	H.	%	S.	H.	%
150	33	3	89.0	26	5	84.0	33	9	73.0
170	18	18	50.0	15	16	48.5	14	28	32.0
190	10	26	27.8	5	26	17.0	8	34	16.7
210	2	34	5.5	0	31	0.0	4	38	8.7
230	0	36	0.0	0	31	0.0	0	42	0.0
250	0	36	0.0	0	31	0.0	0	36	0.0

TABLE II. *Second Part.* PALM PRESSURE WITH HAND REACTION

A second set of experiments was made upon palm pressure with hand reaction. These were the same as in the first set except that the steps between the stimulus magnitudes were made 10 instead of 20 as in the first set; 44 series were taken upon both experienced reagents.

REAGENT W.					REAGENT B.			
S. M.	S.	D. S.	D. H.	H.	S.	D. S.	D. H.	H.
150	37	2	1	4	36	3	1	4
160	30	0	4	10	29	1	4	10
170	20	0	3	21	13	2	6	23
180	7	1	4	32	5	3	4	32
190	5	0	8	31	4	2	0	38
200	1	1	2	40	1	2	2	39
210	0	0	0	44	0	0	0	44

By placing D. S. judgments with S. judgments and D. H. judgments with H. judgments and adding the percentages of S. judgments to number of series, the following table is obtained:

REAGENT W.				REAGENT B.		
S. M.	S.	H.	%	S.	H.	%
150	39	5	89.0	39	5	89.0
160	31	13	70.1	30	14	68.5
170	21	23	48.0	15	29	34.2
180	8	36	18.1	8	36	18.1
190	6	38	13.6	8	36	18.1
200	2	42	4.6	3	41	6.8
210	0	44	0.0	0	44	0.0

TABLE III. FINGER PRESSURE WITH ARM REACTION

The terms mean the same as in table I. The steps between the successive stimulus magnitudes have again been reduced from 10 to 5 except for the last two. Forty-eight series were taken upon both the experienced reagents.

REAGENT W.					REAGENT B.			
S. M.	S.	D. S.	D. H.	H.	S.	D. S.	D. H.	H.
150	38	0	7	3	39	1	9	1
155	30	0	6	12	32	0	6	10
160	22	0	5	21	16	3	10	19
165	15	0	8	25	11	0	7	30
170	4	0	3	41	9	3	3	36
180	0	0	0	48	2	0	0	46
190	0	0	0	48	1	0	0	47

On the Relation of Muscle Sense to Pressure Sense 9

By placing the D. S. judgments with the S. judgments and the D. H. judgments with the H. judgments and adding the percentages of S. judgments to the number of series, the following table is obtained; no naïve records were taken:

REAGENT W.				REAGENT B.		
S. M.	S.	H.	%	S.	H.	%
150	38	10	79.1	40	8	83.2
155	30	18	62.5	32	16	66.7
160	22	26	45.8	19	29	39.5
165	15	33	31.3	11	37	22.9
170	4	44	8.3	3	39	18.9
180	0	48	0.0	2	46	4.2
190	0	48	0.0	1	47	2.1

TABLE IV

In this table are presented the percentages of "same" judgments under all stimulus magnitudes for all sets of experiments.

S. M.		150	155	160	165	170	180	190	200	210	230	250
Passive Palm Pressure	W.	77.7	63.8	44.2	16.6	8.0	5.0
	B.	87.8	61.0	44.0	14.5	9.5	4.5
	N. R.	80.5	58.0	37.0	15.0	7.5	1.0
Part I Active Palm Pressure	W.	89.0	50.0	27.8	5.5	0.0	0.0
	B.	84.0	48.5	17.0	0.0	0.0	0.0
	N. R.	73.0	32.0	16.7	8.7	0.0	0.0
Part II Active Palm Pressure	W.	89.0	70.1	48.0	18.1	13.6	4.6	0.0
	B.	89.0	68.5	34.2	18.1	18.1	6.8	0.0
Finger Pressure Arm Reaction	W.	79.0	62.5	45.8	31.3	8.3	0.0	0.0
	B.	83.2	66.5	39.5	18.9	18.9	4.2	2.1

From this table one may be able to observe the reduction in the threshold that has taken place as the result of the introduction of movement into the process of discrimination. However, it may be more easily seen in the following tabular statement. Under passive palm pressure 170, 190, and 210 bear about the same relation to the standard as 160, 170, and 190 do to the standard

under active palm pressure, and 155, 160, and 170 do to the standard under finger pressure with arm reaction:

Passive palm pressure.....	(150)82.7	(170)62.4	(190)44.1	(210)15.5
Active palm pressure.....	(150)89.0	(160)69.3	(170)41.1	(190)18.1
Pressure with arm reaction...	(150)81.1	(155)64.6	(160)41.75	(170)13.6

The percentages of correct judgments under the standard are fairly constant throughout all the sets of experiments, the average being 83.2 per cent. The perception of sameness is a very definite thing and hence difficult to make. From these experiments it would seem that there is a strong probability that, when the heaviest stimulus magnitude is easily discernible from the standard, and there is, between the heaviest and standard, a series of stimulus magnitudes differing by equal steps, the standard will be judged the same something more than 80 per cent of the time. Even the experienced reagents who know the conditions under which the observations are taken must find themselves sorely pressed by the fact that between the double pressures five out of six times the second is actually heavier. The various influences that combine to fix the number of correct judgments under the standard and the compared pressures will come up again for discussion. Our table here shows what stimulus magnitudes are alike for judgment or sensation.

After the conclusion of the third set of experiments some observations were taken upon passive palm pressure to discover whether any perceptible effect had been made in practice increase. Eighteen series of observations were taken upon both the experienced reagents. The percentages of S. judgments to the number of series are given in the following tabular statement:

S. M.	REAGENT W.	REAGENT B.
150	76.2	83.3
170	61.0	61.0
190	22.3	27.8
210	16.6	16.6
230	00.0	11.5

Only under the stimulus magnitude 190 does there seem to be any change in the direction of practice effect. Here the reduction is about 18 per cent. The irregularities are too great to make this reduction certainly due to practice effect or other sim-

ilar influence. It may be remarked that both reagents had taken, before the beginning of these experiments, numberless unrecorded series of observation in the general work of the laboratory. Furthermore, when a comparison is made between the records of the experienced and naïve reagents, there does not seem to be difference enough to warrant a conclusion that practice has any demonstrable effect upon the power to discriminate pressure upon the passive palm. A new reagent seems to show some uncertainty at first, but that passes off after the first three or four sittings, and afterwards the reagent does about as good work as the most experienced.

Certain individual differences are with some assurance demonstrable. These concern the native power to discriminate and the personal attitude which the reagents assume toward the experiment. Reagent W. shows a tendency to use H. and D. H. judgments more frequently in cases of uncertainty than reagent B. Such a tendency results in giving a lower percentage of correct judgments under the standard and a higher percentage under the compared pressures. In the following tabular statement the percentages of S. judgments in all sets of experiments for both reagents under the stimulus magnitudes that admit of comparison are given:

S. M.	REAGENT W. *	REAGENT B. *	DIFFERENCE
150	82.2	85.4	3.2
160	58.0	53.0	-5.0
170	44.5	40.6	-3.9
190	28.6	26.4	-2.2

The differences here show what would be expected from the predisposition in cases of doubt to render one kind of judgments rather than the other. This individual difference comes out again in the use which the two reagents make of D. S. and D. H. judgments. Of such judgments reagent W. uses 115 and reagent B. 112. Reagent W. gives 19 D. S. judgments and 96 D. H. judgments. Reagent B. gives 38 D. S. judgments and 74 D. H. judgments. They both use about the same number of doubtful judgments, but show a difference in distribution of the two kinds, which favors the predisposition here mentioned. In some obser-

vations taken by the method of right and wrong cases this same individual difference is to be seen. Reagent W. took 398 observations and used the judgment "same" 187 times and the judgment "heavier" 211 times. This gives a difference of 24 in favor of H. judgments. Reagent B. took 352 observations and used the judgment "same" 190 times and the judgment "heavier" 162 times. This gives a difference of 28 in favor of S. judgments. An individual difference, similar in the respect that some reagents were disposed to render H. judgments rather than others, came out in the experiments of Martin and Müller.¹ As their method differed from ours the results are not entirely comparable. They attribute their findings to differences in muscular vigor and strength of reagents. While this suggestion may be applicable to the present experiments, as the less muscular feminine reagent has given results that accord with the suggestion, an empirical study of the two reagents and their modes of judging would by no means support the view that the tendency to render one kind of judgment rather than the other had anything whatever to do with the muscular endowment or the bodily vigor of the reagents. It appears like a subjective attitude entirely to say one thing rather than another in cases of doubt. The reagents know that five out of six times the second is heavier and they may incline toward saying "heavier" on account of the stronger probability of being correct. One reagent may then take more chances than another. The difficult thing is to be able to detect the presence of the same weight following the standard, and both reagents always had it in mind to keep the percentage of errors here down as low as possible.

The point of departure for our work was found in the observation that when the hand is held in a fixed position and a pressure allowed to rest upon any skin area—in these experiments, upon the skin of the palm—the feeling does not remain in any one place, and in successive applications of the pressure it does not return to the same definitely localized area of the skin. Furthermore, when one lifts a weight, with whatever care to do it in

¹Loc. cit.

the same way, he will not feel the weight in the same way or in the same place. The strains brought out by the weight will shift from place to place, and in successive liftings they will appear in differently localizable parts of the lifting member. Fechner called attention to what he has termed the natural mode of making discriminations, which is through a combination of what has been called since Weber's time pressure and muscle senses. This distinction has been uncritically accepted and retained. Our problem has been to show that they differ only in the greater freedom of movement in the so-called muscle sense. Pressures and movements are found in both only in different proportions.

'Introspective study, oft and carefully repeated, has failed to reveal anything that can with much propriety be called pressure sense. If one allows a pressure to rest upon the hand for more than a few moments, unless the amount be equal to a pound's weight or more, the pressure will scarcely produce any effect at all. Unless some slight muscular twitchings arise now and then to increase or decrease the pressure for a moment, the effect will soon disappear and remain unobservable. If, however, one studies the effect of the pressure exerted by the cork used in these experiments from the moment it is applied, he will discover that the pressure is felt now in the skin beneath the cork, now in the increased area of contact of the hand's back with the support through the recession of the hand from the pressing cork. Again, on the skin there will be no pressure at all, but a stretching of the skin, first in one radius and then in another, running out from the cork as a center. Furthermore, although every care has been taken to make the cork set upon the skin with perfect evenness, the contact is felt now in one part of the cork's circumference and now in another. In addition to all these differences one will feel, first here and then there, a twitching of the muscles in the palm. One muscle vibrates, another contracts, another is strained, and another is relaxing. First one of these factors and then another is the object of attentive action. The twitching or increased tension of one muscle from one application to another may shift the tension or the place of pressure in the skin, and so change the locations of the stimulations. If, now, one will care-

fully introspect and observe the happenings in the palm during a number of successive comparisons of the standard and the compared pressures, he will find that the heavier—the case is the same whether a heavier or a lighter pressure is used—pressure may force the skin down deeper and so excite new points among the internal tissues. Perhaps the skin is depressed against the bone or against a tendon and so displaces it. Now, knowing that this is a heavier pressure or that a heavier pressure is likely to be given, this change in the location of the stimulation will be attributed to the presence of the heavier pressure. Again, one observes that a greater recession of the hand has taken place because new local points on the hand's back are excited by its being brought into closer contact with the support. The irradiations of the tension in the skin from around the cork may extend to points on the skin that are felt to have been unstimulated, while the standard pressure was upon the palm. Other muscular contractions than those before mentioned as being due to the presence of the standard may be discerned because of their differences in location; the strains may reach farther out or spread in other directions. If these observations be correct, and they are easily verified, it will be seen that a heavier pressure is different from the standard by the fact that different local signs are excited by the heavier pressure. Let one, however, not be misled by this shifting of the point of stimulation and these changes in muscular tension and confine his attention as closely as possible upon the cork and its point of contact with the skin, and try to find out what are the differences in stimulations which two pressures of greatly and easily discernibly different weights excite, is there then anything of greater, that is, more intense, stimulation by the one and less stimulation by the other? Does not one arrive at the judgment of difference through the fact that one excites certain local signs that the other has left unexcited? These local signs may attach themselves first to the different points in the skin's surface that are depressed by the cork; the heavier pressure depresses a greater area and this is determined by the local signs of the parts so depressed. Or these local signs may attach themselves to the different layers of tissues between the

palm's front and back sides. Local stimulations in the deeply lying tissues or in widely separated areas are interpreted to be the results of heavier pressures. The judgment is based, for the most part, upon the discovery that there is some new local sign excited which had not been affected by the previous stimulus. This interpretation will throw some light upon the fact that the standard pressure does not always appear to be of the same weight.¹ The reason is that the local stimulations produced by the standard pressure change from application to application. Sometimes, then, a new local sign will come out with startling effect and cause a judgment of heavier to be rendered. Furthermore, when heavier pressures approach the standard, they are very likely not to excite any local signs, except those that have come out some time with the standard, and hence the heavier pressure is judged to be the same, since there are no local sign differences that may not be due to the stimulations of the standard. The stimulations that are produced by a pressure, however carefully applied and removed, are many and variable, and it is a practical impossibility for a reagent to take account always of the same group of local signs or for the same group of local signs so to fuse every time the standard is presented, that the group may be always recognized or that it can be known as different from that which a heavier pressure will excite. A difference, sometimes discriminated and sometimes not, will be due to just this fact, that the local stimulations of the same pressures will now be different, and of different pressures will now be the same.

When one compares the stimulations produced by a pressure that rests upon a stationary part of the skin with those that come out when the member is made to move and the skin area is brought against the pressure, he will find many of the same kinds of phenomena. Before speaking of these it might be well to mention the fact that there are likely to be accompanying visual images. Sometimes the balance operates in the same way as lift-

¹The illusion of larger weights of equal heft with smaller of the same external appearance being the lighter is to be explained by the fact that the smaller forces the skin down upon locally different tissues within the hand that have not been affected by the larger weight.

ing with free-arm movements and so gives the impression of a heavier weight by the fact that the cork gives way before the reacting hand less rapidly and the impression of a lighter weight by giving way more rapidly. When a heavier pressure is applied, sometimes the arm seems to be moving through a heavy fluid, sometimes the cork seems to stick fast and refuse to start immediately, and again the balance is apparently impelled on its return by an extraneous force that acts just as the balance is reaching its resting place. These different forms of imagery come up at different times and sometimes one will persist during several sittings in successions. However, we should be inclined to think that the visual imagery of the moving balance is not so important or decisive for discrimination as it is with free-arm lifting.¹ But if one gives attention to the stimulations which occur in the arm, he will find the lifting movement brings out tensions, strains, and stresses, first in one locality and then in another. The stimulations of the movement shift from one locality to another just as in passive pressure; they do not appear constantly in any one area. The lifting movement is accomplished now with one muscle or group of muscles and now with another muscle or group of muscles. This happens in spite of all the efforts and precautions one may take to carry out the lifting movement in precisely the same manner. It can not be done with any certainty or regularity. One can come nearer doing this with the balance than with free-arm movements. In the case of lifting movements the stimulations are distributed over a much wider area than in passive pressure, and hence they are more numerous and variable. They affect more tendons, joints, skin areas, and muscles. A given change of stimulus will cause a wider irradiation of these stim-

¹The theory, developed by Müller and Schuman, that differences in weight are discriminated by the rapidity with which one weight rises and the slowness with which another rises only shifts the point upon which the explanation of discrimination must turn. Upon *a priori* grounds there is no valid reason for thinking that perceptions of rate of movement are more accurate or fundamental than perceptions of resistance to movement. As we shall suggest, all discrimination rests upon getting one combination of peripheral effects from one object and another combination from another object. One combination means one thing and another combination means another.

ulations in the lifting member than the same change of stimulus in passive pressure. The heavier pressure will arouse local signs in more widely separated areas of the member, that is, they will irradiate out farther from the point of contact with the cork and so they will be recognized as coming from different localities. As the whole hand and arm are active, the irradiations due to the increased pressure, where they tend to increase, must take place in a single direction up the arm or arrange themselves in something like a serial order. The errors of judgment upon the standard are about the same as in passive pressure, but the chances that new stimulations will arise by which a heavier pressure may be inferred are greater, and thus follows the decrease in threshold of discrimination. When the changes occur in a locally serial order rather than first along one radius and then along another, each change will be more likely to affect a local sign that has been unaffected by a different, that is, a lighter pressure, and so give a basis for the judgment of heavier. When, however, the pressures approach one another, there will be the same tendency for different pressures to invade the same areas with their stimulations and thus give a realm of uncertainty in which the judgments may fall either way, depending upon the probability that the stimulations arouse local signs that are not stimulated by other pressures.

These occasionally excited local signs may be looked upon as being included for passive pressure within a circular area surrounding that within which lie the local signs most frequently excited by the standard. The occasionally excited local signs may then vary by extending out upon any radius from a center which is the point of application for the pressure. For active pressure these occasionally excited local signs lie along several radii that extend out from the point of application on a single side; the possible directions in which they may vary are less than for passive pressure. Could we now find a muscle group which in making discriminations varied only in a single direction, the discriminations must become more certain in proportion as the muscle is possessed of a high degree of nervous control. Such muscle groups are found about the eyes. The contractions taking

place in convergence, in lateral deviations, or in accommodation of the eyes present a single serial order of change rather than diverse orders. The contractions—the different degrees of contraction—may be looked upon as giving something more of the same kind or as taking place in the same direction. In the movements of raising the arm or bending the finger, each step in further contraction may involve the excitation of other muscles and the stimulation of other tendons, joints, and skin areas. In the eye movements the changes are due entirely to the excitation of the muscle sheaths, increased tendinal strain, and the folding and stretching of the skin and other sensitive tissues. But eye movements give only space discriminations. Still greater and less movements must change the strains and stresses about the eye in a way that is not very different from the changes that are induced in the arm muscles by lifting larger and smaller weights. Certain combinations of stimulations mean different amounts of excursion, and other combinations mean different amounts of resistance overcome. Discrimination doubtless reduces itself at bottom to one and the same process.

Discrimination must be looked upon as a functional process, a part of life activity. It is the process by which we make accurate adjustment to our environments; by which we come to know one thing from another. Elementary discrimination is to be found in the instincts. Every instinct is an inchoate discrimination of the object that excites it. When these instinct performances become conscious, as they do for the most part in men, they form perceptions, and each perception implies making a distinction between its object and all other objects taken together. Such discriminations are perforce qualitative. When two objects are reacted to differently and the reactions are felt, the objects are felt to be different. No object, then, is known until it has awakened some form of reaction. The development of choices between objects belonging to the same class—those that have heretofore invited the same reactions—shows the beginning of what subsequently becomes quantitative discrimination. The earliest form of this is found in such instincts as the mating of birds and other monogamous animals. In most of these cases the animals are so

much alike that it requires considerable search to find a difference, and when such a difference is found it is not a something more of the same kind, but a new and entirely different fact. Now try, for example, to make a discrimination between two male English sparrows. That distinction will rest upon the fact that one has a crooked toe or a ruffled tail feather. Such points are new facts. A chicken will give a different peck for objects lying at different distances or in different directions. Large and small jumps mean for a dog different things. Such responses seem to follow along one line in their changes or they change in the same direction, which gives to them the suggestion of being quantitative in character. That, however, belongs to our reflection upon the matter. The scale of values is to be found in our representation and not in the things. The dog makes one spring in catching a mouse and a very different one for catching a ground hog, and in this way he has made a distinction between the two. Reflection places one beside the other as larger. Primitive discrimination took the form of measuring objects by laying them over a part of the body or of laying the body against the objects. One object is greater than another or more extensive than another, or a group is more numerous than another, by the fact that one excites a local sign that the other has not affected. This local sign means another thing, something that the other has not. An object is represented as a thing that will excite a local sign upon the toe at the same time that it excites another local sign on the heel, and it is then a foot—long. Another object will excite simultaneously a local sign upon the shoulder and the tip of the forefinger; it is then a yard—long. All these local signs have been given an orderly arrangement—they have been put into a system which means our body. But each local sign is something in itself every time it is excited. The local sign is to be looked upon as a functional process, a stimulus evoking an adaptive movement. The local sign thus becomes the unit of composition in mental life; it is a unit of conduct or adaptive movement. Counting and numbering began by matching different parts of the body, as the fingers, with different parts of the object or of different objects; each thing or part of a thing calls for a move-

ment. Discrimination is bound up very closely with movement—different movements meaning different things. One object is different from another because it has something that the other has not and this something invites another or a different movement. This is about the point to which we brought our discriminations of pressure—one pressure is different from another because it excites something that the other has left unaffected.

The difference between pressure sense and muscle sense is not one of kind at all. The two are essentially only different aspects of one and the same process, and that is the process of knowing the differences between objects of the world. It is not, then, a question whether these objects affect the skin surface, the tendons, the joints or muscles, and so bring out the reactions upon which the differences between things must finally rest. The point is whether one object affects one sensitive part to bring out one reaction and another object affects another part or the same part in a different manner that will bring out a different reaction. Our local signs are just so many points which, when affected, do bring out different reactions or tendencies to reaction. If one object affects a certain group and another object affects the same group with some additions we say that these two differ intensively. When movement is eliminated from the act of discriminating weight, the stimulations which the weight sets up change in different directions and shift from one direction to another in successive trials. As movement is introduced, the stimulations are more likely to vary in a single direction and are greater and more constant in this direction for given amounts of difference in stimuli. Each increased stimulus magnitude seems to add some more of the same kind as that already there—a new point on the scale. When the changes are confined to a single order, finer discriminations may be made.

The movement of lifting is initiated by a complex mental state which is the result of the peripheral effects of a previous movement that has accomplished the lift. When one is about to make a lifting movement, the members that are to do the lifting are adjusted to the positions which they have occupied in previous liftings of weights whose indications are the same as the present

weight. Whatever stimulations may have been felt in former liftings of the weight are now present in the mental state exciting the adjustments. Should these be felt or made to tally with the representations that have brought out the adjustment, the present weight is adjudged to be the same. Should the felt series not correspond with the represented series, that is, should some of the represented series fail to appear, the weight is adjudged to be lighter, but should others than those represented appear, requiring further movements of adjustment, the weight is judged to be heavier. The main difference between what has been called muscle sense and pressure sense is the prominence of this representation of the movement which is about to take place. In pressure the representation of the hand undergoing certain stimulations is there and a considerable part of those representations is of muscle strains and tensions. They are weak and pale by comparison, for they are confused and almost blotted out by the stimulations to which the hand is subjected by the apparatus used to exclude more obvious movements. If we attempt to exclude movement by imposing a voluntary rigidity, the feelings of this adjustment are equally confusing and distracting. The various strains, stresses, tensions, etc., which come out with any kind of movements, whether of rate or against resistance, present themselves in some simple form of imagery such as we have mentioned above. In ordinary daily life light weights appear to us generally to move up rapidly and heavy ones more slowly. The discrimination of rate is no more easy or fundamental than the discrimination of resistance. Judgments of same and heavier are inferences from certain facts and these facts are the excitations of areas in the one case that remain unaffected in another. It might be added also that the basis of the judgment that one thing is more than another may not be a more intense stimulation or a more intense sensation. Perceptions of greater do not necessarily rest upon greater perceptions, and a sensation of intensity is not an intense sensation.

LINCOLN, NEB., U. S. A.

THE UNIVERSITY OF NEBRASKA LIBRARY

All communications regarding purchase or exchange should be addressed to

still to be had.

A few copies of volumes I, II, III, IV, V, and VI, complete in numbers, are

Single numbers (excepting vol. II, no. 3) may be had for \$1.00 each.

A list of the papers printed in the first two volumes may be had on application.

Index and title-page for each volume are published separately.

plete in four numbers.

Volumes I, II, III, IV, V, and VI, of UNIVERSITY STUDIES are each com-

UNIVERSITY STUDIES

Published by the University of Nebraska

COMMITTEE OF PUBLICATION

C. E. BESSEY

T. L. BOLTON

F. M. FLING

H. ALICE HOWELL

W. K. JEWETT

L. A. SHERMAN

W. G. L. TAYLOR

CONTENTS

I	MORPHOLOGICAL VARIATION AND ITS CAUSES IN <i>AMBLYSTOMA TIGRINUM</i>	✓
	<i>J. H. Powers</i>	197

LINCOLN NEBRASKA

UNIVERSITY STUDIES

VOL. VII

JULY 1907

No. 3

I.—*Morphological Variation and Its Causes in Amblystoma Tigrinum*¹

BY J. H. POWERS

In the *American Naturalist* for June, 1903, the writer published an article which dealt with the causes of variation in the time of metamorphosis in *Amblystoma tigrinum*. During the observations and experiments which led to this article, and still more during a long series of experiments subsequent to its publication, occasion was offered to note the great variation in this species in its specific and even generic characters. A record of these observations was begun, as well as a collection of specimens, which latter has been supplemented during the last two seasons by an extended series of photographs.

To record these variations is an easy matter, but at the same time, in the writer's opinion, a matter of secondary importance. The extreme variability of the species has long been known and has been fairly well recorded, though still inadequately, by Baird and Cope. To ascertain the nature and the causes of these variations, however, is at once a more important and a more difficult task.

Baird and Cope have, it is true, themselves pronounced very decided opinions upon the causes of many of the variations in

¹Studies from the Zoological Laboratory, The University of Nebraska, under the direction of Henry B. Ward, No. 71.

question. But here I found, almost from the start, that, whatever the true causes might be, my observations were negating or greatly modifying their conclusions. And it was first as a consequence of this that I began systematically to collect facts and verify apparent conclusions. In this paper I shall present a statement of some of those results, together with such illustrations as space will permit, deferring to some future opportunity the arrangement of my material in more detailed, complete, and statistical form.

It will be interesting to begin by stating the general view of Baird and Cope as expressed in Cope's work on the *Batrachia of North America*. The general view there expressed, as to the nature of nearly all the individual variations in *A. tigrinum*, is that they are the result of variations in the time and the degree of, i. e. the completeness of, metamorphosis. No experimental evidence is adduced, but the assumption seemed to the writers to agree well with the character of the variations themselves. Sometimes it is made with reference to the conditions of the whole individual animal; more frequently it is invoked to explain some single or a few eccentric features. Thus differences in general body proportions, in the length and form of the tail, in the width and form of the muzzle, the development of the tongue and the palatal teeth are all ascribed, in one way or another, to varying degrees of "embryonic tendency," i. e. to the partial retention of one or more larval characters.

As the external cause of these variations Cope assigns differences in season and temperature, varying with varying geographical habitats. "Specimens from New Jersey are almost always more fully developed than those from western regions; the former is a warmer district than the latter." He adds, however, that "of two specimens from New Orleans only one exhibits the dental characters of the New Jersey individuals."

A second group of variations, such as the depression of the digits, compression of the tail, etc., are assigned by the above writers to the direct influence of the environment; in the cases of the organs mentioned, to the persistence of the aquatic habit in adults.

The inadequacy of these general assumptions first became evident when, within the narrow radius of six or eight miles, I began to collect many of Cope's most important geographical types. At the present time, indeed, judging as best I may from Cope's written descriptions, it would seem that I have found nearly if not the entire gamut of recorded variation in this species. Some of these varieties have occurred rarely except under experimental conditions. But considerable differences in temperature have not been found necessary in producing them, and continued search within the same narrow area has added yearly to the number of peculiar types found in nature, until the amount of natural variation equals, I think, if it does not exceed that recorded by Cope from the extensive collections of the National Museum and the museum of the Philadelphia Academy. Varying geographical habitat is, then, not a necessary factor in the production of these variations.

As to the persistence of larval characters through partial, interrupted, or asynchronous metamorphosis, I find this, although not correlated strongly with differences of temperature as a cause, to be a real, though only a minor, factor of variability. Variations in the development of the tongue, which may yield adults in every condition, from those with thick tongues filling nearly the whole floor of the mouth to those which show (rarely) quite tongueless larval mouths, are plainly of the nature which Cope assigns. And in the case of this character more than of any other I have had instances in which a retarded development seemed to be due to metamorphosis at low temperatures. Curiously, too, other instances have occurred of fine adults without tongue development in which the retardation was due to the retardation and interruption of metamorphosis by high feeding at high temperatures (30° C.). Variations in the character and the curve of the palatal teeth, which I may say in passing are much greater than recorded by Cope, are also in part, though in part only, interpretable in terms of departure from or retention of the typical larval arch of teeth.

But, aside from these features which do conform in part to the principles laid down by Cope, I find little else among the whole range of the variations of the species in harmony with them; or

if a harmony exists, it is a harmony with the general principles only, requiring quite new applications. Cope had indeed, in common with many others, a thoroughly wrong idea of metamorphosis itself. He viewed the process as one, not only initiated by external conditions, but controlled throughout by them; external conditions might initiate, accelerate, retard, and even reverse metamorphosis. At least Cope embodies in his work approvingly the observations and interpretations of Schufeldt, which go as far as this. Moreover, Cope and Baird seem to assume that metamorphosis may be interrupted or arrested, not only as a whole, but with regard to almost any single character or group of characters. Sexually mature adults may thus result, showing the most varying degrees of larval relationship. I find such a view strongly opposed to the facts. Variable as is the species as a whole, and variable as are the age and the size at which metamorphosis may take place, the process as such is relatively uniform; it is, so to speak, a violent one, initiated, as I have shown in the article above referred to, usually by a check in food supply, but when it once begins, it runs its course well-nigh regardless of external conditions. Its rate may be retarded considerably by lowered temperature and by certain other conditions, but, barring extremely rare exceptions and such as can hardly occur in nature, the animal issues from its period of change, be this rapid or slow, having undergone about the same degree of transformation. The transference of larvae from a warm pond in August to the darkness and low temperature of a deep covered cistern has often yielded me adults almost indistinguishable from those that metamorphosed simultaneously in the pond. If color patterns were frequently modified, structures were usually not affected.

Indeed, so far are my observations from sustaining Cope's view of varying metamorphosis as the source of adult variations, that I find the very opposite to be the general rule: metamorphosis is a leveling process, tending to produce uniformity, not diversity.

The larva may, in perhaps something more than a figurative sense, be said to be the parent of the adult. Metamorphosis is a kind of rebirth and redevelopment, and during its accomplishment

many of the special, acquired characters of the more plastic larva (which is, however, in this species, so much like an adult animal) are lost. The resulting adult reverts back, as it were, to the commoner characters of the specific type. Without stopping to defend my comparison of metamorphosis to reproduction, I will say that it may be taken as nothing more than an emphasis upon the fact which I have so often observed, viz., that an unusual, eccentric larva is transformed during metamorphosis into a less unusual, less eccentric adult. Metamorphosis is primarily a leveling process, accordingly, and in much lesser degree a process productive of variation.

Nevertheless, although metamorphosis obliterates many variations of the larva in part or in whole, it fails to obliterate many in part or in whole. This brings me to the core of my conclusion, which, for clearness sake, I will state here at the outset: the variations of *A. tigrinum* are acquired variations of the larva. They are due, not, as Cope thought, to partial metamorphosis failing to obliterate typical larval characters, but to the fact that complete and perfectly normal metamorphosis obliterates but a portion of the many acquired characters of the larvae. The study of variation in this species thus becomes chiefly the study of the larva; and the study of the causes of variation becomes the study of the special conditions of larval life as well as the special life activities which bring about the variations.

Without attempting completeness, and avoiding, in the main, minor characters, I will discuss the following points: first, variations in elongation of the general body form, or the ratio of transverse to longitudinal dimensions, including in this, in a general way, both the head and the tail; second, variations and causes of variation in the special form of the tail; third, some of the many marked alterations in the shape of the head; fourth, variations in the posterior feet and limbs. Finally, I shall discuss at some length the remarkable modifications in many organs of the body which result from the special habit of cannibalism. This last will constitute the most striking instance of acquired characters which I have to record, and, indeed, one of the most striking, I think, which has ever been recorded as occurring in a natural species.

VARIATIONS IN GENERAL BODY FORM

These are very considerable in the species; very slender as well as very robust individuals are frequent, while now and then occur forms of surprisingly extreme proportions. This variation is, moreover, quite independent of the plumpness or fatness of the animal. The most massive specimen may be gaunt and lean, while the slenderest specimens occur in the highest condition. In judging the robustness of body form it is necessary completely to ignore transverse diameters in the midbody region; they are wholly worthless. In the feeding season, after breeding has taken place, many males of the species linger in richly stocked feeding grounds for weeks and often eat themselves out of all semblance to normal proportions. Not only the digestive tract, but the body walls distend more and more, becoming loose and flabby unless the animal is gorged with food. Artificial feeding may frequently produce still more distention. Such animals have at times a curiously unsalamandrine and even pathological appearance. They are perfectly healthy, however. But this distention of body has nothing to do with permanent body form such as I consider as variation in this paper. These highly fed animals never maintain their condition for more than a few weeks, the feeding impulse always tending to rhythm or irregularity, especially when the food supply is abundant. However constant this latter may be, the animals suddenly, without loss of health, lose their appetites entirely. Following this the body walls suddenly undergo a marked contraction, even while the animal is still in the water. The soft-bodied, greedy meat-eater, of walrus-like proportions, that reveled in aquatic life, becomes in a day or two slender-bodied, wiry, restless, and absolutely bent upon shifting its abode from the best of aquatic feeding grounds to even the most undesirable of terrestrial conditions.

It is necessary, then, wholly to discard transverse body measurements in the middle region. There remain the possibilities of transverse measurements in the pelvic or the pectoral regions or of the head. None of these is satisfactory, the former two because they vary most with the animal's condition; the latter be-

cause it is, as will be shown, subject to the most independent and extreme variations. All in all, however, the width of the head is the most available dimension to use as a measure of the animal's robustness. It is easily measured, and, despite notable deviations, there is a more or less general correlation between its width and that of the hipgirdle, etc.

Taking, then, as a most general expression of bodily proportion, the ratio of the width of the head to the total length of the animal, we find a general variability in the species that is very great. Cope records measurements for the species, showing the width of the head entering the total length from 7.88 times to 10.78 times. This no doubt includes sex differentiation (the mature males being, as I shall show later, proportionately longer tailed than the females) as well as ordinary variation. My own measurements of adults show a still greater variation, the width of the head entering the total length from 6.42 times to 11 times, although allowance for a little exaggeration must here be made, in that some of these measurements were from formalin specimens while others were from chloretoned living animals. Formalin decreases the length out of proportion to the breadth. Still, as great variation as that indicated by these figures undoubtedly exists. I have made no experiments especially intended for the production of extreme forms, and my records of extreme types have nearly all been made during a single season only. I have preferred to work for the causes of a variation that was perfectly obvious, rather than merely to accumulate figures. It is, however, of interest to point out that this degree of variation in general body proportions is equal or in excess of that pointed out by Cope for the entire genus *Amblystoma*, in which he recognized twelve American species. Complete measurements for all the species are not given; but such measurements are given for nine species, showing a range of variation from 8.06 to 10.79, and such partial measurements as are given for the remaining species indicate that their complete measurements, if given, would extend these limits little if at all.

Now this great variation, which Cope assigns to irregularities in metamorphosis or to the age of the adults, I find to be largely

performed in the larva, and to be due to conditions affecting larval development. I have measured non-mutilated larvae of so surprising proportions that the width of the head entered the total length little more than 4.5 times, while in very slender larvae the width of the head may enter the total length nearly eight times. This range of larval variation probably approaches nearer the limits of the species than does that given above for adults. I have handled more larvae and have collected more extreme types. Yet still more slender larvae than the limit mentioned above probably exist or might be produced experimentally.

This range of larval variation as given above is the more remarkable in that it does not to any great degree include sex differentiation, as do the measurements given for adults. Most of the larvae I have mentioned have been too young to admit easily of sex determination. When kept until sexual maturity is reached, some time after metamorphosis, it turns out that the more robust (not larger) larvae become more frequently females; the more slender (longer and on the whole larger) become males. Yet this does not hold for larvae grown under certain exceptional conditions, nor for all larvae grown under normal conditions. In my last season's catch I secured beautiful larvae grown under typical conditions among which undeveloped males showed a breadth of head entering the total length but 5.86 times; while a slender female larva now in my aquarium shows a width of head entering total length 7.85 times. Variation in the general body form, then, is not primarily or chiefly a matter of sex. Reference may here be made to plates I and II and also to plates VII, VIII, and IX. These figures were not chosen with especial reference to illustrating this part of the text, but are useful in this connection: figure 1, plate I, shows a very robust form; also figures 1, 2, and 3 on plate II; figures 2 and 3 on plate I are typical specimens, especially 3; figure 4, plate II, is a slender type. The later plates show mainly more extreme animals developed under less typical conditions.

Turning now to the causes of these general variations, I find, by field study as well as by observations upon developing animals in my experiments upon metamorphosis and coloration, that they

comprise four sets of factors, viz., diversities in nutrition, diversities in habitual locomotion, diversity in the age at which metamorphosis occurs, and, in case of sexually mature larvae or ordinary adults, diversity of sex. I have repeatedly observed the operation of each one of these factors singly; and extreme types of body form are always due, in my experience, to special combinations of appropriate factors from these classes. Thus the most elongate forms of *Amblystoma*, speaking generally, are due first to slow growth, second to the free-swimming habit, third to the prolongation of larval life, and finally to the assumption of sexual maturity as males, this last occurring in either the branchiate (larval?) or the non-branchiate condition.

The influence of a slow rate of growth is very marked indeed; although I ought, perhaps, to say an intermediate rate of growth; for if nutrition is checked to the point of approximate starvation or to that where the animal merely holds its own, the results are again quite different. I will not discuss these here. The rate of growth to which I refer is, for an intermediate sized larva of twelve to twenty centimeters, approximately a centimeter per month.¹ A rapidly growing summer specimen may more than quadruple this amount. The easiest method of inducing this moderate or slow growth is by winter feeding. Larvae which have slipped through the late summer without metamorphosis pass into a curious condition of low metabolism, or relative quiescence. It is not hibernation by any means, but yet, as it were, an approach to hibernation. The change is but partially, if at all, due to temperature, and it is only very slowly and partially overcome by temperature. Metamorphosis is almost impossible during the early winter months, no matter to what conditions the larvae are subjected. Such larvae, if kept at living-room temperatures, readily take meat and thrive, although they will not eat more than once or twice a week, whereas summer larvae under like conditions require daily feeding to prevent immediate metamorphosis. These slowly grown winter larvae invariably show a marked change in form, the body, tail, and even the head increasing in length, but hardly at all in width. The tail increases in length more rapidly than the body. This change of form, although more

marked in some larvae than in others, is independent of the type of larva upon which the experiment is made; robust individuals become elongate, slender ones still more so.

Winter growth, however, although the easiest, is by no means the only means by which this elongation of the animal may be induced. A temperature of 15° C., provided the animals are inured to it before they have reached the size at which metamorphosis is possible, produces similar though less marked results, growth under such circumstances easily becoming too slow. Figure 4, plate II, shows such a larva, one-third of whose growth had taken place in a cistern. Again, among any large number of summer larvae, a very few will be found which are by nature very light feeders, or which have formed some special habit inconsistent with heavy feeding. These individuals always show the results of their light nutrition, frequently becoming beautifully elongated and graceful types. In nature they frequently become very large, approaching in length the limits of the species; this is because the slow growth prevents metamorphosis until complete maturity has been reached.

As to the nature of this elongation it should be especially noted that these animals owe none of their slenderness to emaciation. The very contrary is true; they are unusually rounded in contour, and indeed not infrequently are excessively fat. I was struck with this curious fact the first time that I ever had occasion to contrast an extremely massive with a slender larva. While netting 10 cm. specimens for experimental purposes, a chance stroke of my dip-net brought me an astonishing specimen: a perfect larva, of but 18 cm. length, yet with a head 4 cm. in width. Its feet and limbs, too, were well-nigh proportionately massive. Yet despite these prodigious lateral dimensions the specimen was the leanest larva I had ever seen, gaunt and cadaverous.

Seeking immediately for a living specimen of its own length with which to compare it, I found my largest laboratory larva to be 17.7 cm. in length. Although its body seemed loaded with tissue at every point, its head measured but 2.2 cm. in breadth, and limbs, tail, etc., all with the slenderness of the type. It had been

a regular but light feeder and had attained its slender and graceful proportions by slow but prolonged growth.

The effects of a continued free-swimming habit, as opposed to quiescence at the bottom, are, when the contrast can be well observed and the habit is prolonged, hardly less marked than the effects of slow growth. Specimens raised in the same aquarium or in similar aquaria side by side, with all conditions as uniform as it is possible to make them, seldom fail to furnish striking examples of broad-headed, short-bodied, and short-tailed types which are habitually found at the bottom, while others, slender and elongated, are free swimmers and maintain themselves in almost as continual suspension and motion as does a gold fish. Figure 1, plate IV, shows a young adult from such a larva, greatly shrunken by preservation, it having measured, when chloroformed, 19.7 cm. in length and but 1.8 cm. in width of head. It was the last to metamorphose out of several hundred specimens which I fed with meat in a small enclosure in a pond. Together with several other specimens of the same type, it maintained the free-swimming habit all summer in its narrow quarters, while the majority of the specimens, lying lazily at the bottom, metamorphosed much earlier, as short-tailed, robust individuals. Out of this same series the three most slender larvae did not metamorphose at all. In some instances this type of differentiation may be found working on the wholesale in nature. Thus two summers since I had occasion to follow closely the development of larvae from April to September in a small pond. A few specimens were netted almost daily and again returned to the pond. Food (daphnids and chironomous larvae) was very abundant; the number of larvae was limited, and growth of all was very rapid. Yet despite the uniformity of these favorable conditions, the larvae soon began to split up into two noticeably distinct groups, the one of unusually compact proportions, the other of uniform intermediate build, such as is most commonly met with. Figure 1, plate I, and figure 2, plate II, show side and dorsal views of the robust type, the adults from the same larvae being shown on plates III and IV. Figure 3, plate I, shows a side view of a free-swimming larva. It is but moderately slender, or rather

of typical build, being the result of the free-swimming habit with abundant food. Figure 2 of the same plate represents a corresponding larva, a little more slender, from another pond where food was less abundant. It will be noticed that the tail fins of the two compact larvae are much mutilated, while the more slender specimen from the same pond has but a single mutilation. This contrasting condition was invariable with the two types, save that many of the free swimmers showed no mutilation. This condition was due to the numerous crayfish which lay in wait for the larvae at the bottom but which could not reach the others. Other proofs of their differing life habits might be given. In regard to these special larvae I shall recur to one such proof in speaking of variation in the case of the posterior limbs. I may say, however, that as to the existence and persistence of the types I have had abundant opportunity for observation under conditions that permitted of no doubt. Even in aquaria the differences in habit as well as structure become very marked. The lazy, heavy-bodied animal, wanting oxygen, will raise the head and start slightly upward, relapse again into quiescence, again start forward, and yet even a third time, before it finally raises itself unwillingly to the surface, to take in, when it finally gets there, an enormous gulp of air. On the other hand, the swimmer never waits for a second impulse when its respiratory period (the animals usually rise at regular intervals) is completed, and not infrequently comes close to the surface as if for oxygen when no real need has yet arrived.

I have made considerable effort to ascertain what the causes might be which lead the animals thus to differentiate their habits of locomotion, feeding, etc. Sufficiently precise observations are not possible in the field. And in aquaria often no cause whatever can be assigned. The animals somehow seem different. I have a little evidence that hereditary predisposition is sometimes at the basis of the incipient differences, which rapidly gain in force as habit becomes fixed.

In other instances, however, a perfectly evident cause does exist for the assumption of divergent locomotor habits, these latter being, it would seem, forced upon the animal by a sudden and rapid change in the form of its development. A weak-limbed,

long-bodied, and long-tailed animal becomes well-nigh perforce an undulatory swimmer; while the strong-limbed, short-tailed, heavy-bodied specimen, when these characteristics are rapidly forced upon it, is, under certain circumstances, just as forcibly induced to become a crawler. In such instances, where the development plainly at first conditions the action, the cause is again purely nutritive. I will mention a single instance of two larvae which in the course of a few weeks assumed such different modes of locomotion that, with their equally contrasting appearances, they never failed to call out a burst of laughter when displayed to a laboratory visitor. In my experiments upon metamorphosis I placed, at intervals of a few weeks, a number of larvae, under 10 cm. in length, in a flat pan, two feet in diameter, with but an inch of water, and the whole so tilted that the larvae were well out of water on the shallow side although covered at the deeper side. Most larvae, though not all, are checked in their feeding for a time by this treatment, and some become very light eaters. Such animals soon take on a very slender form, and are as rounded and graceful in outline as they are slender. In the experiment alluded to one larva especially became thus modified, growing slowly but steadily, and retaining its larval condition longer than any other fed larva among the hundreds of my laboratory specimens. It resembled figure 4, plate II, save that the head was still narrower and the general outlines more slender and evenly cylindrical, with gills and limbs still shorter. Despite the shallow water which, according to all common theories, should have stimulated the animal to a systematic use of its limbs, it used these members less and less, until finally the posterior limbs were never used at all, the soles remaining vertical when the animal was at rest, and the whole limb being appressed to the side the moment that locomotion began. And very regularly did this individual take its exercise, circling round and round its narrow quarters, vigorously ascending the shallow side by means of strong serpentine movements. So striking were these movements and so much did they exaggerate the effect of the extremely slender form that one seemed to see in this animal a variation which might indeed lead to a Siren or an Amphiuma.

In astonishing contrast to the form assumed by this animal, and still more accentuating its peculiarities by the effect of contrast was the form assumed by another larva introduced into the same pan a few weeks later. It was one of the few whose appetite was in no wise checked by the change in surroundings; on the contrary, the stimulus of the new food (chopped liver) brought about a period of prodigious feeding. A hypertrophied development of a type which, in greater or less degree, invariably results from such eating followed. The animal developed in all its lateral dimensions, save perhaps breadth of mouth; the head became almost triangular in outline; the gills, with thick, heavy rami and luxuriant fimbriae, carried out the lines of the head by growing backward, cape-like, two-thirds of the distance to the posterior limbs. The body became daily heavier and more distended, until almost the semblance of salamandrine proportions was lost. The more so in that the back, frequently out of water, became devoid almost of fin and perfectly smooth, and the tail, although still quite larval, remained narrow and extremely short. The limbs were strong and were used upon the slightest provocation. It was this latter fact that accentuated to the last degree the apparent unlikeness of these two animals which, at six centimeters in length, had resembled each other as closely as if members of one brood. Stimulate the two by jarring the pan, and while the slender larva swept about, even in the shallowest water, with its graceful, limbless, serpentine curves, the other, disdaining entirely the use of its body and well-nigh entirely of its tail, struck out with limb movements so vigorous and so rapid, although it could not travel through the shallowest water, that one observer exclaimed: "It looks for the world like a mouse in a wash bowl." This instance, though extreme, is none the less typical of a number which I have closely watched, in which distinct habits of locomotion have obviously been imposed upon the animal as the result of its nutrition. Once started, these habits of locomotion again react upon the structure. But it seemed of interest to establish the fact that initial differences in appetite alone may finally result in the production of individuals differing from one another quite

as much as do distinct species. Our discussion of the results of cannibalism will enforce this.

Regarding the third factor which I have mentioned as a cause for variation in general body proportions, viz., the age at which the animal metamorphoses, little need be said. The facts are simple. Indeed, considering the enormous variation in the size at which *A. tigrinum* may undergo metamorphosis, it is surprising that the resulting adults do not vary much more from this cause than proves to be the case. I have had hundreds of larvae, in ponds as well as in aquaria, which metamorphosed at ten centimeters in length, or even considerably less. The resulting adults, sometimes weighing but three or four grams, are tiny things compared to the giant larvae which may grow in one summer to weigh 180 grams. My largest larva, three years old, has now broken all records with a length of something more than 33 cm. This larva will probably never metamorphose; but other giants, which exceeded the size hitherto recorded for adults, after breeding at the customary time in the spring, promptly defied the tradition as to the perfect axolotl, by metamorphosing; and this in spite of the cold running water and the darkness in which they were kept. As already stated, these great variations in metamorphosis are of rather minor morphological consequence. Indeed, in certain organs, noticeably the palatal teeth, I find that the extremes of precocity and of delay in metamorphosis produce well-nigh invariably the same type, and a type not frequently found among the intermediate conditions. In general body proportions, however, this is not the case, the small adult resulting from early metamorphosis being larger headed and shorter tailed than the larger adult resulting from later metamorphosis. Even this difference, however, so far as it relates to the tail, is little more than a special case under the general law of slow and rapid growth. The small larva (if it is capable of metamorphosis) has grown rapidly; the larger larva has grown more slowly, at least during the later portion of its development.

The fourth factor which I have indicated as influencing the general form is the factor of sex and sexual maturity. As I have said, there is probably a certain average sex dimorphism even

before sexual development as such begins. I have not ascertained this by measurements because of the difficulty of determining the sex of immature specimens. The difference, however, is not great, and not only do exceptional individuals occur, very slender larvae becoming females and robust individuals males, but under certain special conditions of development the general law is set aside altogether, excessively robust larvae producing, in the rule, males and not females. This general-exception will be explained under cannibalism.

The chief point to be noted, however, under the relation of sex to general bodily form is that, with the advent of maturity, a marked sexual dimorphism appears. The tails of the males undergo a considerable change in form and most noticeably an increase in length. This secondary sexual character seems to be invariably acquired simultaneously with the development of enlarged cloacal lips and of the testes. The only exceptions are cases of extremely poor sexual development due to under-nutrition. A few such animals become sexually mature males without the customary lengthening of the tail. Measurements were made of thirty young males, after metamorphosis but before attainment of sexual maturity, and again, early the following season, after the attainment of sexual maturity. These showed a lengthening of the tail in all but three cases of extremely meager or pseudo-development. That this change was not due to simple growth is shown by the fact that the length of the head and body had increased in but two of the most highly fed individuals, while in at least four it had actually decreased, at times by as much as 5 mm. Moreover, measurements of twenty-eight young females from the same lots and kept under same conditions showed an actual shrinkage in entire length in eighteen individuals, this being chiefly due, in most cases, to a shortening of the tail. Of the six individual females that showed growth one only showed a special extension of tail of 2 mm. This lengthening of the tails of the young males with the approach of sexual maturity, though general, is, like many secondary characters, extremely variable. In four of the above instances it equaled or exceeded 2 cm.; its average was a little over one centimeter. The increase is entirely by

growth at the tip, as evidenced by its extreme thinness and lack of pigment; spots of color which showed in the immature animal at or near the tip being, after the elongation, removed by the same amount from its extremity. So thin are these tail tips during the first season of their development that the extension of the spinal column shows on either side as a strong convex ridge along its middle. Only very gradually does this secondary growth take on the character of the original portion, and it always remains relatively thin.

A further question occurs, viz., whether this caudal elongation which accompanies the first advent of sexual maturity is followed by subsequent elongation with each recurring cycle of sexual development. Cope thought that animals with very long tails were very old; and if, with each yearly period of sexual development, the tail increased in length disproportionately to the body, his assumption would be borne out. As a general rule, however, I do not find this to be the case. Besides, I find that very slowly grown larvae may produce males that equal, in their first season's sexual maturity, Cope's extremest measurements, i. e. forms in which the tail equals or even exceeds the length of head and body. Nevertheless, I do find that this sexual character is capable of repeated expansion, in case the animals are very highly fed during the summer. The tail does not grow disproportionately during the period of feeding. Rather the reverse seems to be the case. But when the animals are taken from the earth the following spring another increment of the tail is evident, rendering this member still more disproportionate. Even several old males, after excessive feeding had been induced, showed this power of renewed tail-growth. I hope thus, by repeated feeding, to produce excessively long-tailed animals, suggestive of some related types. In nature, however, this repeated extension of the tail certainly takes place but rarely. The average *Amblystoma* does not get sufficient food, it would seem, after metamorphosis, for even moderate growth.

By careful study a number of means may be discovered of judging or estimating the age of animals taken in nature: yearlings can be certainly told by the form of the tail, and two-year-

olds by the same means; older animals are not only different in these respects, but become much scratched and worn by burrowing. The skin about head and jaws becomes loose and wrinkled; both the character of the pigment and the color patterns become altered; while the most definite, if the most trivial, means of estimating age is by the number of notches in the dorsum of the tail, due to the bites of rodents. Young animals never show many bites, while those that are much worn, etc., show the dorsum of the tail completely serrated. Such animals can hardly be less than ten to fifteen years old and are very probably more. Judging of age by these means, the forms of very old specimens do not prove to be peculiar, and there is no evidence of continual elongation of the tail save in very rare instances.

Finally, it is of interest to note that this same sudden elongation of the tail accompanies the assumption of sexual maturity by the male amblystoma in the branchiate (so called larval) condition. I have not been able to observe directly the development, because I have not been able, despite repeated trials, to develop sexually mature male aquatics in aquaria. But larvae placed by me in a reservoir have attained a superb sexual development, even so soon as at the close of their first summer; and by comparing the males among these specimens with the females, with ordinary larvae, and with immature males from the same source, it was quite evident that the peculiar elongation of the tail had taken place just as it would have done had metamorphosis preceded the assumption of the breeding condition. The largest of these males measured 29 cm. in length, and over half of this length was comprised by the tail. These specimens had grown slowly for the first half of the season, consequently assumed the slender form, and the sexual maturity of the males had brought the tails up to almost the extreme length.

A certain special interest attaches to this assumption by the so-called larval, or axolotl form of this secondary sexual character. Whether or not it actually is assumed by the Mexican axolotl I have been unable to ascertain. But the development of this character by our sexually mature aquatic amblystoma shows (together with many other features, such as size, coloration, etc.)

how natural the aquatic life is to the species, provided that the perfect conditions therefor are present. My former impression was that the permanent aquatic type was produced only by continuous nutrition at low levels. I have produced them thus in cisterns, and I am now experimenting with such animals taken from the lakes of high altitude in Colorado. They are undoubtedly of the species *tigrinum*, but are a dwarfed and stunted race, though perfectly mature sexually. Such animals as these may perhaps be spoken of as "larvae," which have been retarded in development as the result of a "hemmung." But such amblystomas as I have described above are animals of the most superb development, despite the fact that under proper conditions they may undoubtedly remain perfectly and permanently aquatic. They outgrow all ordinary adults; they breed naturally, females depositing over a thousand eggs at the first spawning. And, as I have indicated, they show delicate morphological as well as color characters which classify them as perfect adult animals. It is true they are subject, even after breeding, to the accident, the fatality, of metamorphosis; but neither this nor their analogy to other larval forms makes them in any true sense of the word "larvae." In many if not in all respects they are the most highly developed adults that the species is capable of producing. Much less is there any scientific reason for designating, as has been proposed, these sexually mature branchiate amblystomas as axolotls, in distinction from the sexually immature branchiate, for which the term "larva" is to be reserved. The popular term axolotl has no scientific value, nor is it applied solely to sexually mature individuals of the species in its Mexican habitat. And again I may add that there is no gain, but much loss, in seeking to explain or even to classify these phenomena by the use of the term "neoteny." The use of this word "neoteny" merely stereotypes with a high sounding title a partial knowledge and a thoroughly false interpretation of the facts. The only scientific mode of expressing the facts would be to speak of *A. tigrinum* as a dimorphic species, possessing an aquatic as well as a terrestrial form. The fact that the latter is developed only by passing through the for-

mer does not rob the former of its natural and complete independence under appropriate conditions.

Herewith I have spoken of the chief factors which control the general bodily form, although I have dwelt chiefly upon the factors which produce elongated rather than shortened forms. The production of the one is the reverse of the production of the other.

SPECIAL VARIATIONS IN THE FORM OF THE TAIL

A glance at the tail contours on plates III and V, although the forms figured illustrate by no means all of the phenomena, will show that there is much to be explained. There are long tails that are broad, and long tails that are narrow, and short tails broad and narrow; there are tails that are thick and fleshy, and tails that are thin; there are (at least in animals out of my experiments) tails almost round and tapering to short, sharp tips. And with all these there is a host of minor though not unimportant variations. I shall discuss only a part of them.

Length having been already explained, I will next speak of the matter of breadth. Fairly extreme cases of varying tail breadth are shown on plate III, figures 1 and 2. The explanation of such differences offered by Baird and approved by Cope is that they are caused by the varying degrees of aquatic habit of the adults. Thus Baird is quoted by Cope as saying: "A more persistent residence in water is shown by the broader and more depressed digits, *higher and more compressed tail*, and more or less decided ridge (sometimes even membranous). I have no doubt that an animal while possessing these features in marked degree when in water would lose them to a measurable extent after a lengthened residence on land. This aquatic habit is generally greatest during the breeding season." I am glad to be able to confirm in some degree these assumptions, and I have been to the trouble of keeping several lots of adult amblystomas for fully two years in water of different depths, besides feeding a great many other adults, both young and old, in water for varying lengths of time up to four months. I have also taken pains to ascertain as care-

fully as possible how aquatic the species naturally is in my own vicinity. To sum up in a few words the results I have reached, Baird's assumption is true in so far that it proves possible to develop broad, compressed tails in some adults by high feeding in water. The variation thus induced even becomes in a few cases quite remarkable,—see figures 1, 2, and 3, plate V. And again, life in a burrow for even a single winter may considerably reduce the breadth of the tail, while old females, kept for several years in moist earth, without access to water, show tails that are almost cylindrical at the base. Rapidly growing summer larvae, too, when forcibly induced to undergo metamorphosis out of the water, develop into adults with tails very unlike those of the species. They are short, cylindrical, and taper rapidly to a sharp point. They resemble the tails of *A. opacum* rather than of *A. tigrinum*.

Striking as the above facts are, however, and confirmatory of a considerable measure of truth in Cope's and Baird's hypothesis, they are not a sufficient explanation of even the major part of the phenomena of tail variation. This is shown by the following considerations: *first*, young adult amblystomas, taken immediately after metamorphosis and kept for three years under the same conditions as to food, temperature, aquatic and terrestrial conditions, do not develop like forms of tails. *Second*, most adult individuals, despite such fluctuations as I have mentioned above, maintain a fairly constant type of tail from year to year, provided they are kept under approximately normal conditions. *Third*, the broadening of the tails by enforced aquatic life of the adult is, of all the varied modifications that may be produced under experiment, the most erratic and uncertain. In a few young specimens, just after metamorphosis, it may take place in a few weeks; others under the same conditions show no effects after months or even years, while now and then an individual that has shown no change during a year of aquatic life will suddenly show an eccentric caudal development. *Fourth*, under experiment the tails of females seem, on the whole, more easily modifiable than those of males, and the modification may become very marked,—see figure 1, plate V. In nature I have never found a female showing more

than a very moderate degree of compression. *Fifth*, the form of tail produced, both in the male and in the female, is more or less unique and is unlike anything seen in wild specimens. In the female, the tail, though broad and compressed as in figure II, plate V, is thick and fleshy to the tip and even on its dorsal ridge. In the males it becomes much thinner, especially at the tip (most of all after attainment of sexual maturity); seldom is there a very slight membranous dorsal border. In nearly all males, however, the whole dorsum is so much thrown into folds that the dorsal ridge becomes quite ruffle-like. Even the thick tails of the females show something of this transverse corrugation of the dorsal moiety due to the hypertrophy of this portion. *Sixth*, the maximum breadth of tail in wild individuals is not only confined to the male sex but is a seasonal character present only in the breeding season. I can fully confirm Baird's statement that the animals are most aquatic at the breeding season, with the further addition that the males are very much more aquatic than the females, lingering in the water, provided that food and shelter from light are present, for weeks after breeding is past and the females have left. These facts look as if the aquatic life of the male produced the caudal swimming organ; and possibly, if we are sufficiently Lamarckian in tendency, we may suppose that in the long run such has been the case. But further observations show that it is not, at present, an annual adaptation. It takes place before the animals enter the water in the spring. This I have observed both in wild adults caught en route to their breeding places early in March, and in many adults which I have wintered in boxes of earth in cellars. That it should occur, however, requires that the animals should have passed the winter at a suitable temperature and that they shall have been sufficiently well fed the preceding season. *Seventh*, the whole matter of tail-form, aside from the minor sexual difference, proves to be chiefly a matter of nutrition. The tail is about the first organ to show the results of undernutrition, and the occasional excessive expansions of the organ in water never take place, so far as my experience goes, save as a result of continued high feeding. I have found no means of feeding amblystomas to the maximum which does not

involve keeping them for a good portion of the time in water. Last season, however, I was able so to situate thirty adults in their third summer that they ate prodigiously and yet were out of the water, in a fairly moist atmosphere, for the greater proportion of the time, and when in the water they practically never swam, but only crawled lazily about. The tails of many became twisted permanently to one side under these circumstances. But this did not prevent the customary hypertrophy of a number of specimens which showed broad and thick, or corrugated thin tails according to sex. The broad tail thus need not be a highly functional swimming organ. *Eighth*, and finally, the chief point which I wish to emphasize in regard to this organ is that, however much it may be modified in the adult (and by artificial means this modification may become prodigious), its customary variations are not due to this means, but, like all the chief variations in this species, are preformed in the larva. Not only the tail fin of the larva, but the tail as well, varies very greatly in width. A glance at plates I and II will show something of this, although no slender-tailed types are there shown from the side. A comparison of figure 1, plate I, with figure 2, plate III, will also show to what extent the tail of the adult resembles that of the larva minus the finfold. A slight reduction in the robustness of the tail does take place, differing in different individuals according to the state of nutrition and the circumstances of the metamorphosis, but these changes are unimportant and relatively uniform compared with the very considerable variations in form of the organ due to the accumulated influences of larval life. I have been unable to figure any extremely long and slender tailed adults for want of space. But a comparison of figures 1 and 2 in plate III is interesting, especially when the history of the two animals is known. Both specimens owe their peculiar tail-form to larval development, and not to changes subsequent to metamorphosis. The short, broad-tailed adult (which is, I may say, a more extreme animal than the other) was photographed a few weeks after the completion of metamorphosis. Moreover, it proved to be very constant in form, showing surprisingly little change after seven months' terrestrial life in a rather warm basement, or again after a summer's heavy

feeding in water. Further, it is interesting that this breadth of tail was not due, as I have said in speaking of the larva, to the swimming habit, but to the very opposite cause, viz., to rapid development at the bottom, with excessive nutrition. The slender-tailed adult is the result of slower growth, mostly in a cistern, where the specimen metamorphosed after about a year and a half of slow growth. It is therefore an example of form produced by slow growth, and to some extent of the free-swimming habit. The larva from which this specimen resulted was similar to figure 4 on plate II. This specimen was not photographed until several months after metamorphosis, and in order to test the permanence of these slender-tailed adults, this individual and several like it were kept in water and fed to the utmost, alternately on meat and on daphnids, for an entire season. The specimens became very fat, to judge by external appearance, but none underwent significant tail expansion, this being one out of many instances in which I have observed the tendency of rather extreme forms to remain permanent, or even to increase their variation rather than develop toward a supposed norm.

I may now add a word of explanation concerning the broad tails of figures 2 and 3 on plate V. Figure 3 represents a rather slender adult, not unlike figure 1, plate III, at the time of its metamorphosis. After being kept in water for nearly a year subsequent to metamorphosis, the tail underwent, rather suddenly, this expansion, the impulse being plainly due to a period of heavy feeding. The special form of this tail is rather unlike most of those among my water specimens. Figure 2 is unfortunately photographed from a preserved specimen which has shrunken somewhat. But it shows my most aquatic adult, after about two years of life in a large battery jar where it had several companions. It will be noticed that the tail is very long, somewhat more than equaling the length of head and body. It is also very high and thin, though scarcely finned. In life the extremity of the tail, aside from the notochordal axis, was as thin as a leaf and the tip was pointed like that of the average larva. Some larvae even have rounded tail tips, like figure 2 on plate I, while most end in a pointed tip like figure 3 on plate I. The shape of the tail in this

specimen is due to a combination of causes. In the first place the specimen was taken in September, as a rather slowly grown, slender larva. It was fed in the laboratory until it metamorphosed in mid-winter, during which time it became a long-tailed larva. After metamorphosis the adult was kept continuously in water for nearly two years. It was a restless, active swimmer, and the tail underwent a gradual expansion until the second autumn, when the animal became sexually mature. Following this another rapid increase occurred in the tail, both in breadth and length. It was at this time that the tail became sharp-pointed and thin at the tip, this being a modification and exaggeration of the change which I have described as occurring in all males upon the assumption of sexual maturity. As stated, this tail tip simulated almost exactly the tail of a rapidly grown, free-swimming larva. I have seen only two others that were at all like it. The character, though a trifling one, is interesting as an example of the very considerable number of unique and definite characters which may be produced in this species by special combinations of life habit and external conditions.

Of other features of the tail I will mention a few merely. The thickness, laterally, is as variable as any other dimension. Of all features, it varies the most during the life of the adult. It varies immensely with the condition of the animals, and much more in females than in males. In the female the heavy dorsum of the tail seems to be as much a store of nutriment, to be accumulated and drawn upon, as is the corpus adiposum. The older animals, however, are apt to have the thickness of the tail absorbed without being able to restore it save under very unusual conditions. Young animals of both sexes are always thick-tailed, sometimes to a surprising degree, and the dorsum of the tail is frequently as thick as the ventral portion; the cross-section thus shows an even oval, which is never the case in old adults. Hardly any variation modifies the appearance of the animal more than this transformation, which is purely a matter of age. In the males, sexual maturity again complicates this change. Not only is the tail lengthened at the tip and greatly thinned at the base, but it is also much lowered at the base, at a point just over the cloacal lips; it

thus appears as if partially disjointed from the body, instead of constituting an evenly tapering prolongation of it. Even this gross thickening of the larval tail, which remains so conspicuous in the young adult, proves to have a perfectly definite and recognizable cause. It is again one of nutrition and activity. When larvae which have reached a considerable size have their nutrition slowly checked there results an equally gradual shrinking of the back and tail fins. The area of this swimming organ may be easily reduced to less than half its former size before metamorphosis really intervenes. This always happens with wintered larvae. When nutrition is again increased the fin surface may reexpand or it may not. Seldom does it reexpand to its former proportions, although the animal may grow meanwhile to twice its former bulk. With every vicissitude in nutrition, therefore, the swimming surface of the tail tends to be more or less permanently reduced relatively to the weight of the animal. If, now, the larva with reduced tail surface is obliged to swim from habit or necessity, there results a very marked increase in the development of the posterior portion of the body, including the tail. The narrow-finned larva makes up in strength what it lacks in surface. I have often verified these results, in aquaria as well as in nature.

VARIATIONS SHOWN BY THE HEAD

Here we find at first a bewildering number of types and individual differences. Of the extent of variation in the breadth of the head relative to the length of the animal I have already spoken. But its other dimensions are no less variable; its length, its thickness, its contour, the rounded, tapering, or truncated muzzle, the development of the so called parotid glands, the distance between the orbits and the nares, and especially the gape of the mouth,—all these are quite as variable as is the width of the head.

To disentangle the factors which might produce these forms seemed at first hopeless. But in the course of over a hundred separate experiments in raising larvae to and beyond the period of metamorphosis, although these experiments were made with other ends in view, yet as conditions were controlled and varied

in different ways, it became evident that certain forms of head were correlated, with partial if not entire regularity, with certain conditions of development. And finally, after three seasons' work and observation, the causes of all the more familiar characters were, I think, worked out with fairly demonstrative completeness.

Omitting for the present the most singular and extreme modifications of the head, due, as we shall see later, to cannibalism, I will speak of some of the chief variations and of the larval habits and environing circumstances which produce them.

To begin with, a small and slender head is usually produced by the same influences which produce a slender body and tail, although, as we shall see, this need by no means be wholly the case. But under normal conditions it is so. Light nutrition and a free-swimming habit tend to produce at least narrow muzzles and usually narrow heads. Figure 4, on plate II, shows this to a moderate degree (some heads and muzzles are, however, much narrower than this) when contrasted with the other two larvae on the same plate, figure 2 representing a very rapidly grown specimen (photographed in August; eggs deposited probably in April), while figure 1 shows a specimen in which moderate growth had been followed by excessively heavy feeding on daphnids and chironomid larvae. The form of the head depends chiefly upon the configuration of the skull itself, but secondarily upon that of the so called parotid glands. These latter are subject to the greatest variations, not only among adults but, as plate II shows, among larvae. And I find that, from the larvae they are transmitted directly to the adult, in which they are, on the whole, permanent under ordinary conditions. The partial exceptions to this permanence are: first, that metamorphosis reduces them to some extent, as may be seen by comparing figure 2, plate II, with the same animal after metamorphosis, shown in figure 2, plate IV; second, severe starvation reduces the parotids to a considerable extent, especially in the young, and conversely, excessive feeding may restore them or even now and then develop them beyond their original size. Nevertheless, these structures tend to be as permanent in the adult as are most other external characters, and with them as with so many other organs it is during the larval life

that they show an extreme plasticity and variation in development. The parotids in figure 1, plate II, are really much thicker than they seem, making up a considerable proportion of the width of the head. In figure 2, plate II, it is rather the sideward extension of the large branchial apparatus that broadens the head, although the parotids are here, too, heavy. Excessively protruding parotids like those in figure 1 are essentially phenomena of overnutrition. Out of hundreds of larvae taken during the same season from the same pond not a specimen showed the protruding cheeks during the summer. But after the great multiplication of daphnids in the early fall, a few weeks sufficed to transform many of the larvae in the pond into the likeness of figure 1. They were feeding very heavily in nearly clear water and were resting mainly upon the bottom. I have observed the same thing over and over again.

Low nutrition, on the contrary, or starvation at certain periods of larval life so reduces these parotid regions that, unless the gape of mouth is very narrow, the sides of the head become nearly or sometimes quite parallel. I have produced a great many such larvae experimentally, and have found nearly similar specimens in nature under appropriate conditions. Specimens from the Seven Lakes, Colorado, where the species is said not to metamorphose, and where sexual maturity is attained at a very small size, show this same parallel-sided head, together with many other signs of the lowest nutrition.

Another result of low nutrition, and especially of periods of sheer starvation, consists in the great flattening of the head. The starvation of large, normal larvae in the fall, the only period at which this can be easily done without producing metamorphosis, often has very striking results of this nature. Such results are erratic, not affecting equally all similar specimens exposed to the same treatment; but some respond to it quickly, and, like so many other effects of transient nutritive causes, this result of starvation is frequently quite permanent. It does not succumb to later periods of full feeding, and is fully transmitted to the adult. This variation is not well shown on the plates, although figures 4 and 5 on plate II, taken from the same animal, show something of it;

and figure 5, had it been taken at the proper angle, would have shown more. In adults, figure 3 on plate III shows a head in which this depression is very marked, while figures 4 and 5 show contrasting heads, larval and adult, of an extreme opposite type. I will explain these latter in connection with the next feature, the gape of the mouth.

Perhaps nothing varies so much as does the gape of the mouth, and with its variation is correlated, directly or indirectly, nearly every other variation in the form of the head. To discover the causes of many of these features was for a long time utterly impossible. Such variations as those already described were obviously due to the causes ascribed. One had but to observe the rate of growth and the resulting forms, together with certain general habits of the larva, and the connection became plain. Season after season similar results followed from similar conditions, and vice versa. Certain cases, however, were much more puzzling, and even offered, in some instances, results that seemed to contradict the principles above laid down. To illustrate by a typical instance: larvae 1 and 3 on plate I and larva 2 on plate II are from the same season's catch in the same pond; adult 2 on plate III and adult 2 on plate IV show two of these same specimens after metamorphosis. It will be observed that they had very large heads, both broad and long; the gape of their mouths was no less striking. Perhaps more striking still, though not shown on the plates, were adults resulting from the more slender larvae, like figure 3 on plate I. The heads here were almost equally large and obviously out of proportion to the bodies. Now during this same summer I raised from the egg a number of specimens in the laboratory, feeding them, in very large battery jars, on the same food—daphnids and chironomous larvæ—which the aforesaid larvae were eating in the pond. This food I netted daily from the pond and supplied to them in unlimited quantities. However, despite the same food, the laboratory specimens soon diverged widely from either the bottom-crawlers or the free-swimmers in the pond. They thrived excellently, though, despite the concentration of their food supply, they grew more slowly. This was accounted for by their constant movement; they were ex-

posed to the light, and with the exception of a single lazy lubber (which grew much larger and more robust) they were in almost ceaseless movement. Still, I could not account for the full difference in their forms and more especially in their heads. One of the adults from these laboratory specimens is figured as figure 1 on plate VI. It will be seen to be rather slender in outline and especially narrow-headed. Yet the whole animal was very rounded and plump, much more so than the pond adults with heads of twice the bulk. The difference, too, seemed to be entirely in the build of the animal, not in accessory structures like the parotids. Finally, the most astounding difference proved to be in the gape of the mouths. Those from the laboratory were much smaller than I had ever seen in *A. tigrinum* before. When chlorotoned and completely relaxed, I could still scarcely open the mouth wide enough to see the palatine teeth. The explanation of this marked contrast was at first not evident, as all these animals had developed on the same food from the beginning. Finally, it occurred to me that the constantly increasing differences might be correlated with differences in the *manner* of feeding. The water of the pond was so muddy that the animals were in nearly total darkness, and their prey, though abundant, was not massed. How did the animals under such circumstances manage its capture?

I placed a number of the pond larvae in a large tank in a basement without windows and supplied this tank moderately with daphnids. By cautiously raising a dim light above the margin of the tank I was able to catch the animals feeding in apparently their characteristic manner. The daphnids were evenly distributed throughout the water, and the larva, opening the mouth and expanding the whole buccal cavity to the utmost, lunged violently forward, trusting evidently to the chance catch of as many daphnids as the large mouthful of water might contain. The straining of the whole buccal and branchial apparatus was very noticeable, and the whole process seemed to be repeated as rhythmically as are the swimming movements of a medusa.

Repairing now to my laboratory jars, I observed the feeding of my larvae in the light upon their much more concentrated food

supply. The contrast was surprising. These larvae were feeding by sight. A single daphnid was seized at a time, and this only when it chanced to come into exactly the appropriate position: the mouth was opened so slightly and the prey seized so deftly that the whole movement was inconspicuous and trifling. Here there was suggested a possible explanation of the different forms of head. The straining of the gape to the utmost, the expansion of the whole buccal apparatus, and the continued repetition of the process might well be the cause of the head expansion in the pond larvae, while the gingerly nabbing of single daphnids by the scarcely opened jaws of the specimens kept in the light might give the narrow head and insignificant mouths of the others. Additional confirmation was necessary, however, and the following spring I introduced young larvae into aquaria kept in the dark. I supplied these again with daphnids, although in but moderate quantity, in order to stimulate the animals to as continuous feeding and as much mouth expansion as possible. The result was the rapid development of larger mouths and broader heads than I had ever produced by ordinary feeding, even when this had been excessive and had resulted in very robust types. In general, too, I had always been surprised that my laboratory larvae, fed on abundant and highly nutritious food, should develop narrower heads than nearly all of those from surrounding ponds. The explanation now became clear. And, moreover, the investigation of a number of ponds in August showed a surprising correlation of broader and broader heads with muddier and muddier water. The broadest headed daphnid-feeders I obtained were developed in a prairie cattle-wallow where the water was kept continuously agitated until it was black with mud. All of the other ponds admitted some light during at least the longer intervals between rains.

This principle, that the head is broadened by random feeding in the dark and narrowed by easy feeding under conditions that allow of the use of the sense of sight, is of course complicated more or less by the results of slow or rapid growth and of free-swimming or bottom-crawling habits, for these latter affect the

head as well as the general form. But it is not difficult in many cases to trace the results of the separate factors.

On plate III are shown, in figures 4 and 5, the heads of a larva and an adult which present proportions very unlike the heads of ordinary specimens, at least as the species occurs in the West. It will be noticed that these heads are excessively high or thick; that they are as short as they are high, and that the gape is so short as to render the mouth very small. Such heads exaggerate the type which Cope has figured as the eastern variety of the species. Could I have figured the entire animals, it would have been observed that, viewed dorsally, these heads seem positively diminutive for *A. tigrinum*. Several adults that I now possess are even smaller-headed still, and had they been obtained from a less known habitat few systematists would, I think, have classified them as *A. tigrinum*, more especially as their colors are as unusual as is their type of form. It may be interesting in passing to contrast these extremely short, thick, small-mouthed heads with an opposite type which I have figured on the same plate. I will explain this head, with its enormous gape of mouth later. I will here note only that the entire length of this animal was (in formalin) but 22.3 cm., while the short-headed adult was 23.2 cm. long, and the larva 25.4 cm., the last two being measurements from living animals.

As to the cause of development in the case of these small, yet thick heads, I have never been able to produce them by laboratory experiments; but have secured nearly two score of them by placing animals in a reservoir where they developed for a full year under conditions that I could fairly well observe. The smallest heads have been produced only in years when the food supply was very light for at least the first half of the season. The water was relatively clear, allowing the animals to feed by sight.¹ No daphnids and few other small, free-swimming organisms were present for food until late in the season, when water-boatmen became abundant. The food consisted of insect larvae, especially of dragon fly larvae, which became in the latter part of the season

¹The size of the eyes varied, but in some specimens it was noticeably greater than in animals of equal size grown in muddy ponds.

very abundant. The general small size of the head and of the gape of the mouth is thus readily explained by these conditions; but the high arch of the profile is not obviously so explained, and I am forced in regard to it partially into conjecture. A partial explanation lies in the fact that whatever tends to broaden the head also tends to flatten it, to reduce its height. These heads were not flattened by any special influence, and consequently assumed a form that, in cross-section, more nearly bears out the lines of the body, which is cylindrical. However, it is probable that a special method of feeding actually tended to shorten the head and to arch the profiles. As I watched the animals when the reservoir was clear they were almost continually seeking food on the bottom. To do this the animal flexes the head sharply downward (the very opposite of the flexure when the animal is seining, so to speak, for daphnids), roots with the muzzle among the ooze at the bottom, and seizes by an occasional jab anything that is seen or felt to move. This method of feeding is extremely natural and is resorted to by the species whenever there are no free-swimming organisms to draw the attention upward. Under such circumstances the mouth is used but seldom and is not widely opened; the downward flexure of the head, sharp as one can flex the first joint of an extended finger, is the dominant feature of the process, and it would seem that this might have something to do with the development of these very convex profiles.

As already indicated, these high-profiled, but small-headed adults simulate and even exaggerate Cope's "Eastern variety." This he thought resulted from the fuller development and more nearly complete metamorphosis due to a warmer climate (New Jersey); whereas the "Western form," with broader, flatter head, was an instance of less nearly complete metamorphosis or "larval tendency" resulting from a colder climate (Minnesota). The specimens just discussed illustrate well the inadequacy of Cope's assumptions. They exaggerate the Eastern form; yet they grew as larvae in the relatively cool water of nearly eight feet in depth. As to metamorphosis, I placed a dozen of the larvae (several of them already sexually mature), in a dark, cold basement, or in a very large, cool cistern. Either of these situations ought to equal

in coolness the Minnesota summer. Yet the metamorphosis ran its course with full completeness, leaving no obvious trace of "larval tendency," and producing adults corresponding to those which Cope deemed had undergone the maximum degree of metamorphic development. Thus the key to the special problems which this polymorphic species offers is not to be sought in the broad differences of general climatic conditions, but in the special peculiarities of purely local habitats.

There remains but a single character in the head of the larva of which I wish to speak at present. This is the form of the muzzle. In all ordinary larvae, larvae during their first summer, the muzzle is rounded in contour. It is narrower or broader according to various circumstances that modify the shape of the head, the width of the gape, etc., but in all such cases it presents a smooth, continuous curve. I have handled thousands of individuals and have never yet seen an exception. The adults, too, in all save the rarest instances, present a rounded muzzle. Figures 1 and 2, plate II, show broad but otherwise typical muzzles of larvae; so do figures 2 and 6 on plate VIII. Figures 2, 4, and 5, on plate IV, show normal muzzles, although the first two are unusually pointed muzzles of adults. Figure 5 is a thoroughly typical wild specimen, while with these may be compared the exceptionally broad, though still rounded muzzles, larval and adult, in figures 1 and 2 on plate IX. Considering how universal is this character, it is surprising to find it readily and regularly modifiable by appropriately changed conditions of the simplest nature. The modification consists in the transformation of the rounded into a sharply truncated muzzle (see fig. 3, plate VI). The conditions which produce it are the prolongation of larval life by very low nutrition, followed by periods of at least moderately rapid growth. Mere neoteny, or wintering, of ordinary larvae does not usually produce the truncation, although it does in some few cases, evidently those where the fall nutrition is also light. Nearly all of my cistern specimens which have undergone periods of more or less intermittent feeding develop this character by the second season, and all of them do so if kept under such conditions for several years. Laboratory specimens, too, have usually developed

the same peculiarity when, by light feeding during late summer and fall, I have induced them to pass through the winter without metamorphosis. I should add that here again, as in the case of slender bodies and long tails, extremely low nutrition, producing a minimum of growth, does not develop the character.

Morphologically, this delicate character is not due to a modification of the skeletal structures of the muzzle. This does not seem to be usually the case with amphibians which show similar muzzles. It consists, in *A. tigrinum*, almost entirely in a growth of the tissues about, and especially above, the external nostril. A kind of supranasal fold develops, forming a somewhat funnel-shaped opening to the nostril, which latter seems also to be enlarged. The cause of this trifling, yet unique, development is by no means plain. Yet there are certain facts, which are interesting for themselves, which throw some light upon it. As to the increase in the size of the nostril, this seems to be, frequently at least, a direct result of starvation or of development under very low nutrition. The same effect may take place during metamorphosis. It is plainly an instance of tissue-absorption, just as are many other changes about the head, e. g. the reduction of the membranes about the mouth, leading to a great increase in the gape.

The development of the projection about and above the nostril is, however, plainly of an opposite character. I deem it to be due to an increase in the use of the nostril for the passage of water in the function of pharyngeal respiration. Pharyngeal respiration has not, to my knowledge, been recorded as occurring in branchiate amphibia, but I find it present, despite their spectacular gills, and it may be easily demonstrated.¹ Moreover, in these

¹I may here add a note on the matter of pharyngeal respiration in *A. tigrinum* both larval and adult. The fact of the former is surprising and adds one more to the already bizarre array of facts on amphibian respiration.

In the *American Naturalist* for July, 1889, O. P. Hay notes, in an article "On Some Habits of Some Amblystomas," the fact of pharyngeal respiration in the adults of three species of amblystoma, *A. microstomum*, *A. punctatum*, and *A. tigrinum*. I have confirmed his observations on *A. tigrinum* with, however, certain differences. Thus I find the period of these respirations to be very close to ten seconds when the animals are quiet;

larvae with truncated muzzles this mode of respiration is probably increased at the same time that branchiate respiration is decreased. This latter is inevitably brought about by low nutrition which,

considerable movement accelerates it. The regularity, however, surprised me, not only in the same specimen from time to time, but in diverse animals under somewhat different conditions. I tested a number of wild adults just taken in water, during the breeding season; also a very large wild adult which had shared an ordinary fish globe throughout the winter with a mammoth larva. Besides these I tested a number of my specimens kept permanently in jars since the time of their metamorphosis. The movements were strikingly similar in all, even in the case of specimens kept in water but just deep enough to cover the bodies. A mere lift of the head was here sufficient to take in air in the ordinary fashion, and the nares could be easily raised, and often were raised, above the water for hours of air breathing. Yet, when the heads were under the respiratory movements did not differ from those of the specimens in deeper water where the indolent animals seemed so loath to rise to the top for air. Instead of ten seconds, Hay gives five or six seconds as the period for *A. tigrinum*. For *A. microstomum*, however, he gives the period as eight to twelve seconds. Another point of difference is that Hay describes the expulsion of the water as by the mouth, whereas, by the use of colored fluids, I observed that it was, in all cases, at least partially by the nostrils, and often entirely so, the mouth not being opened at all.

It was while observing these movements that I chanced to observe that identical movements took place periodically in the throat of the large larva (the one whose head is shown in figure 3, plate VI), and the same movements were verified immediately in all the larvae I had at hand, a dozen or more. The large specimen was the only one sufficiently quiet to enable me to time them; they were regular but much slower than in the adult, averaging very close to one in twenty seconds. I was surprised to find that, in the larva as well as the adult the nostril was employed for the expiration as well as the inspiration, although the former is by the gill clefts as well. By pressing a large globule of magenta solution from a pipette in such a manner that it remained cleanly suspended just in front of the nares, the whole process could be perfectly observed. The globule becomes slowly drawn out into a fine point, which, approaching the nostril, is drawn in continuously, as a fine stream, during the whole interval until the moment of sudden contraction by the buccal floor. This movement sends strong jets of the colored fluid out again through the nostril, and at the same time small clouds of fluid are expelled from the gill openings. I have since tested many larvae, down to ten centimeters in length, and I find the process common to all, though differing noticeably in the force and size of the streams. For in some the nostrils are very fine. I was interested to note further the independence of this process from any connection with branchial respiration. For when watched from below, or from the side, it becomes quite plain that the clouds of colored fluid expelled do not touch, by a long way, the gills, not even when these chance to be dependent rather than arching upward, etc. The entire mass of colored fluid is always shot strongly downward as well as backward, passing usually exactly under the fore leg. I may add that this buccal respiration is very probably common to all branchiate Urodela. I find the same phenomena in *Necturus*.

as I find by repeated experiment, always greatly reduces the size of the gills (see fig. 3, pl. VI).

The question remains, although the answer has already been partially indicated, as to how far these special forms of larval head are transmitted to the adult. The general reply is that they are all retained to a greater or less extent, in so far at least that the young adults, after metamorphosis, show in a partial if reduced degree the form of head acquired by the larva. Even the delicate character of the truncated muzzle is by no means obliterated. Some features are obliterated more, however, than others, e. g. extra width of head is lost more than is extra length. Moreover, the nature of the circumstances of the metamorphosis also conditions the result. Slow metamorphosis at low temperatures absorbs more of the larval tissues, especially if, as is usually the case under such circumstances, no food is taken during the process. Rapid metamorphosis at higher temperatures usually absorbs less, and especially if, as I find to be frequently the case, the animal does not entirely discontinue feeding for more than one or two days of the metamorphic period. Thus slow and forced metamorphosis reduces the width of the larval head more than does rapid metamorphosis or metamorphosis plus some feeding. Or again, and this proves a striking point, slow and sheer starvation-metamorphosis produces an adult with a much wider gape of the mouth than does metamorphosis of an opposite or at least less extreme nature.

Both of these results happen to be exactly the opposite from what we should have expected from Cope's assumptions. As another example, I may mention that metamorphosis out of water has most peculiar results, although these pertain less to the head than to other parts of the animal. And, finally, there is one interesting character, never to my knowledge possessed by the larva, and very rare among adults, that is produced entirely, in my experience, by difficult or retarded metamorphosis. This is the prolonged or protruding lower jaw. It is a chief character in the diagnosis of one of Cope's one-specimen species, viz., *A. xiphias*. I do not recall ever having seen this feature in an adult resulting from metamorphosis during the period from early to late sum-

mer, the time when metamorphosis is most easy. Neotenic larvae metamorphose usually without developing it. Yet a number of large, old larvae, metamorphosing, with resistance, so to speak, in the fall, have shown projecting lower jaws, quite equal to Cope's *A. xiphias*. Out of about a dozen ordinary larvae which I was wintering, and finally induced to metamorphose in midwinter, several developed and permanently retained this same feature despite their later growth to twice the size.

As to the permanence of special types of head in the adult during its life subsequent to the time of metamorphosis something must also be said. For if the various types of head in this species should turn out to be due to nothing more than the varying conditions of the individual as such, fatness, leanness, etc., their importance as variations is much reduced. At first I thought this would prove to be largely the case, that the amblystoma with prodigiously bulging parotids was simply an individual very highly fed, whether during larval or adult life. This supposition was, however, borne out only in part by the facts. I have kept many adults, young and old, for three and even four years, and have subjected them to very varying conditions of nutrition, temperature, etc., and by means of photographs I have compared the appearance of many during successive seasons. Starvation does, of course, produce a marked effect on many organs and upon the animal's whole appearance, save color. More important is the fact that young adults, particularly males, often undergo considerable changes in the size and shape of the head during their first winter, especially if they have developed from very full fed larvae. Heads of good sized specimens may, in extreme cases, lose two to three mm. in width, and this makes a great difference in the proportions of the animal. Probably the change would never be so great as this if the animals were not wintered at too high a temperature. All in all, however, it turns out that sexually mature adults show a nearly constant form of head, so long as they are kept under approximately natural conditions. And even very old adults, although they become much worn and wrinkled about the head, yet show no marked deviation from younger animals of similar general types.

The modification of the form of the head in adults by certain artificial conditions is interesting. For example, I should class permanent aquatic life for this species as artificial, because of, among other reasons, the modification in the species which it produces, especially if the animals are taken when young and highly fed. Certain characters of the head dating from larval life are not obliterated by even this treatment; long heads remain long and short heads short. But other characters are developed which modify the appearance of the animal very greatly and which, coupled with equally conspicuous color changes,¹ render the animals well-nigh unrecognizable as *A. tigrinum*. Zoologists to whom I have displayed such animals have never been willing to hazard a guess as to their species. Notwithstanding variations in degree and some variety in result, these changes are always in the same general direction: the head is broadened and flattened, and something of the same truncation usually appears that was shown to occur in the larva under similar conditions. As to the broadening of the head, a fine typical example is shown in figure 3, plate IV, an animal that had been kept continually in shallow water for over a year. When the experiment began the specimen was an ordinary small-sized young adult, having little resemblance to the figure. It will be noticed that this head is even broader in proportion to length than that of the unusually large-headed adult beside it, which owed its form directly to the conditions of its larval existence. This broadening of the head by life in water does not necessarily imply a robust animal; not a few instances occur of the opposite combination. Figure 6, plate V, shows a dorsal view of the head of the animal in figure 2 of the same plate, although this view of the head was taken before the animal was sexually mature or had reached the length shown in figure 2. The animal was, however, extremely slender in both body and tail, while the head as shown became almost round in outline. The most extreme instance of this lateral de-

¹The writer has in preparation a monograph on the color variation of *A. tigrinum*, which will explain, not only such peculiarities as are shown in the plates of this article, but many others, including several apparently new types. It will also fully explain the differences in coloration on the different portions of the animal's body.

velopment of the head, out of about a score of animals employed in the experiment, is shown in figure 2, plate VI. The head of this animal looks abnormal, yet it developed from an ordinary small adult and showed no signs of pathology. It was not an excessive feeder.

The flattening of the head, although conspicuously present in enforced aquatics, is not well shown in my figures, most of the side views being either of individuals which showed this character but moderately, or else the profiles are not taken at the proper angle to show the character fully. Figure 4, plate V, however, shows it well considering that the specimen is an excessively full fed and robust individual. It had doubled or probably trebled its size during its year or more of aquatic life as an adult. A comparison of this head with the profile outlines given for the different species of the genus by Cope in his *Batrachia of North America* will show how unlike these aquatic profiles are to those of any of the species described by him, with the possible exceptions of *A. copcanum* and *A. xiphias*. Both of these aberrant types are species founded, it would seem, upon single specimens only, and present, I think, no character that I can not duplicate from *A. tigrinum*, either wild or modified by experimental conditions.¹ These characters of depressed and broadened head suggest at once certain lower and more aquatic genera; the truncated muzzle does the same, although this is of more general occurrence in several families. This latter character is chiefly interesting as showing that the adult and the larva (so called) in this species are subject to parallel variations. Figure 3, plate IV, and figure 2, plate VI, both show this slight truncation of the head, induced by the life of the adult in water. In order, however, to avoid the possibility that this delicate character has been augmented or reduced by the process of preparation of the plates, which involved cutting out the photographs, I have added two adult heads merely blocked out—figures 4 and 5 on plate VI.

¹The writer does not wish this statement to be construed as a final judgment in rejection of the species in question. Such a judgment should be pronounced only after a study of the type specimens themselves. It seems probable, however, that a fuller knowledge of the variation of *A. tigrinum* will degrade not only these two species, but at least two others as well.

With these may be compared also figure 6, plate V. Figure 5 is typical; figure 4 shows the character in an unusual degree, and yet it had, in this case, been wholly assumed in one summer's heavy feeding, after a period of severe starvation out of the water. Figure 6, plate V, shows but a trace of the peculiarity, owing to the unusual roundness of the head, and yet the position of the nostrils is still marked by slight angular projections. Figure 5, plate V, shows the head of the adult figured in profile just above it, figure 3, plate V. In this instance the very marked truncation is the result of the assumption of the character by the larva, and later of its reaccentuation by the aquatic life of the adult after metamorphosis.

VARIATIONS IN THE POSTERIOR LIMBS

The posterior limbs are much more variable than are the anterior, and I have, in the main, confined my attention to them. Moreover, I shall limit myself still further to certain special variations which I have studied, viz., first, to the robustness or slenderness of the limb; second, to the habitual posture and manner of use of the limb; and third, to the foot and toes, their roundness or depression with bordering skin-folds, and lastly their basal webbing. I may in passing also mention the variations of the posterior limb in length; they are very great and but partially correlated with other bodily features. Such observations as I have made indicate that their rationale will also be found in different rates of growth together with different modes of function. But my observations as yet lack completeness and definiteness upon this point.

On the matter of the robustness of the limb, however, I have made sufficient observations to reach, I think, conclusive results. The amount of variation in it, too, is very great. Compare figures 6 and 7, on plate IV, with figure 9 of the same plate. The first two figures show but parts of the limb, and the view is not the same as in the last. But a glance shows that these limbs as well as the feet differ prodigiously in the degree of their massiveness. Yet this difference is due neither to age, size, nor sex. All are

from animals shortly after metamorphosis and all were, I believe, males. Figure 7 is from an animal 19 cm. long, figure 8, 21.5 cm., and figure 10, 20 cm. Moreover, figures 7 and 10 are from animals taken the same season, at about the same time, and from ponds where the conditions, though different, were thoroughly normal. Careful observation of animals in aquaria and under different conditions of feeding show the cause to be, here again, one of nutrition, supplemented by the factor, decidedly secondary in importance, of use or disuse. The differences that may result thus with larvae of the same age, of about the same length, and similarly situated in every way, save as to amount of food or habit of eating, are very great. Corresponding specimens may show limbs varying in diameter from three to five mm. respectively, and thus varying in bulk nearly as five to one. My first observations led me to consider this rapid strengthening of the limbs as a change preparatory for metamorphosis; for such larvae, however beautiful their branchiae, proved usually on the verge of change. However, further study showed that many, if not the majority, metamorphosed with very little of this hypertrophy of the posterior limb, and that finally the connection of the sudden limb development with metamorphosis was indirect and not direct, the sudden limb development being due to a sudden excess of nutrition and growth, and the metamorphosis to the corresponding retardation which is so certain to follow the acceleration.

We next come to variation in the feet, and especially the toes. Few characters are more interesting, and nowhere have the results of my observations been more surprising to myself. The amount of variation is again very great, as a glance at the plates, especially plate II and plate IV will show. Baird and Cope described these variations, and, conformant to their usual principles, ascribed them unhesitatingly to varying degrees of aquatic or terrestrial habit in the adult. Nothing seems more reasonable—before we study the facts. Then contradiction arises immediately. I secured old adults whose finely and closely scratched skins, together with numerous other features, showed them to have just emerged from long periods of burrowing life; still they showed

"aquatic" feet of the most extreme type, the toes being much depressed and heavily bordered with folds of skin quite to the tips. On the other hand, a score of large adults that had lingered unusually long after the breeding season—until the 9th of May—in an extra good feeding ground under six to eight feet of water, showed feet of diverse but perfectly usual types, broad toes and narrow toes without sign of adaptive modification. The habits, too, of these animals when in the water are not such as to lead to the development of a swimming foot. At the breeding season the males are nervously active in the water, courting each other as well as the females, and performing astonishing feats of jugglery, carrying a female—or a friendly male who consents for the nonce to the substitution—for yards upon the upraised tip of the snout. But in these movements, which I have watched for hours, they remain almost exclusively upon the bottom, undulating the long tail and even the body from side to side, the feet meanwhile making enormous strides, touching the bottom by the tips of the toes only. The movements of food-seeking, etc., which often alternate with those of courtship, are still more of the nature of walking, unless swarms of daphnids are present nearer the surface; then adults may frequently be seen swimming slowly with an unsteady sidewise rolling motion. The feet, however, play almost no part in the propulsion. And when the animals do swim vigorously, as in rising out of deep water for air, the limbs are pressed tightly to the sides. On the whole, similar statements may be made for the larvae, although the larva seems to me to use the foot more than does the adult in swimming; its use is, however, mainly confined to making sudden turns to the right or left. Very marked variations in this respect also occur, and in the larvae certainly to a greater extent than in the adult.

What, then, is the cause of these varying types of feet, which at first sight do suggest so irresistibly the idea of adaptations to differing degrees of aquatic life? I regret that I must again answer so nearly in the vein in which I have spoken before. But these different types of feet, especially the broad or narrow toes, are again nutrition phenomena. They are developments, in the main, during the life of the larva, not of the adult; and they result,

not from varying degrees of the swimming habit, but from varying degrees of nutrition. The broad foot, with broad depressed toes, oval or even triangular in outline, is a product of what I should call overgrowth, of excessive anabolism; whereas the longer and much more slender toe is the well-nigh invariable result of prolonged, slow, or moderate growth. Compare figures 8 and 9, on plate II. The former shows the hind legs of a robust twenty-centimeter larva out of the same lot as are figure 1, plate I, and figure 2, plate II. Its life had been passed as a bottom crawler, not as a swimmer, and it had attained its massive size by the middle of August, the eggs having, in this case, probably been deposited in April. Figure 9 shows the posterior limb and foot of a slender larva, 27 cm. long, which had grown slowly and continuously for about eighteen months. Such examples are thoroughly characteristic. Figure 7, plate II, shows another slender-toed foot of a slender, slowly grown larva which I had raised. Figure 6 shows a characteristic foot of a slender pond larva of slower growth, the larva being but a trifle shorter than that from which figure 8 was taken and showing an equal preparation for metamorphosis. Figure 10 shows the posterior foot of a mammoth sexually mature larva, one year old, and 27 cm. in length. It had outgrown all its companions by a centimeter or more in length, this superiority being, however, much less relatively than its excess of growth in peripheral parts, viz., in parotid glands, gills, and breadth of toe.

But are these depressed toes with bordering skin folds retained by the adult? Weismann includes the cutaneous margins among the larval organs which are lost during metamorphosis. Observation of many instances shows that this may or may not be the case; frequently there is a little absorption, less frequently there is a good deal, or none at all. Moreover, in cases of this character, metamorphosis accentuates rather than reduces the larval variation, but, curiously enough, in a manner exactly opposite to the general principles of Cope's assumptions, in that slow metamorphosis at low temperatures reduces the larval foot and produces very slender round toes, and this is especially accentuated if the larva was already a slender-toed example grown at the low

temperatures. On the other hand, a broad-toed specimen, overloaded with tissue at every point, undergoes, in suitable environment, an easy metamorphosis in which the destructive metabolism does not attack the feet at all. Figures 11 and 12, on plate II, show the foot of a rapidly grown specimen, photographed in nearly the same position, one before and the other after metamorphosis; they will be seen to differ very little in breadth of the toes. On plate IV, I have again blocked out the feet of several characteristic adults. Figure 6 shows the foot of a slender adult nearly 19 cm. in length. Although not from the same specimen, it corresponds closely to the larval foot, figure 6, plate II. Figures 7 and 8, of plate IV, show the very slender-toed feet of two individuals (21 and 19 cm. respectively) which had been fed for about nine months in a cool basement, and which metamorphosed there as well. The slenderness of these toes is very evident, especially in figure 8, which shows the limb of what was originally a very short, robust specimen. A little more rapid growth followed by metamorphosis in its first season would have turned out a foot like figure 9. This latter is the foot of a rapidly grown specimen just after metamorphosis from a larva much like those from which figures 8, 11, and 12 of plate II were taken. Contrast this foot, figure 9, with that in figure 7, bearing in mind that both animals were photographed at about the same time after metamorphosis, that both are males as yet not sexually mature, and both healthy animals attaining full sexual maturity at about the same time thereafter; the possessor of the foot in figure 7 was nearly 22 cm. in length and that in figure 9 but 20 cm. Another illustration of the slender toe is shown in figure 10, plate IV. It is from an adult wild male nearly 28 cm. in length, all the lines of the body and head showing it to be the result of very slow larval growth.

In speaking of the feet, I have thus far considered only the depression of the toes and the presence or absence of the cutaneous borders at their sides. It may seem like excessive attention to detail to separate from this latter character the matter of the webbing of the toes at their bases. None the less, I find that the two characters are not necessarily correlated and are not pro-

duced by wholly the same conditions. And as in the study of variation the important thing is not the impressiveness of a character but the success with which we can trace it to its causes, I shall devote a word to this delicate peculiarity separately. First, I may say that the webbing at the base of the toes is now and then present, to a surprising degree, in old animals, and, like the broad and depressed toes, it is, as I know by experiment, by no means necessarily reduced by periods of burrowing as opposed to aquatic life. Moreover, like previously described characters, it is developed wholly during larval life. I find it decidedly more resistant to metamorphosis, starvation, etc., than are most other plastic and variable structures. Figure 8, plate IV, shows considerable webs between bases of the toes, despite the narrowness of these and the actual reduction which they have undergone. In fact, I have found it possible to reduce the toes in some instances until they were almost claw-like, with very delicate, cylindrical and tapering tips, without detracting at all from a considerable membrane at their bases. As to the cause of the development of this feature during larval life, my observations are less complete than I could wish. The character is more frequently determined early in the larval life, at a time when I have had less chance for observation. But such observations as I have made indicate a purely Lamarckian origin. It develops, usually at least, about in proportion as the young larvae use the feet to walk with. In one instance, even in a large larva, I accidentally hit upon conditions that very noticeably developed this "aquatic foot." A large, slowly grown larva over 20 cm. in length, with slender toes, was carefully slipped through its first summer without metamorphosis. It was then placed in an ordinary fish globe kept on my table throughout the winter. Here it grew slowly but continuously until much too large for its quarters. Unable to expand fully, and unwilling to lie coiled upon the disagreeable convex base of the globe, it finally hit upon the fixed attitude of resting upon the curved tail and the two outspread posterior feet which were expanded to the uttermost. The body, raised thus to a semierect position, threw much weight upon the posterior extremities, which became very strong; while the feet, though the toes re-

mained of the type shown in figure 9, plate II, became more fully webbed than in any specimen which I had previously seen. I have repeated this experiment with more or less success upon several larvae, wintering one specimen, which became over 20 cm. long, in a one-quart Mason jar. This individual adopted a similar attitude and with similar results in the posterior feet. But the development was eventually checked when the captive adopted, very successfully, the reverse habit of standing, for the most part, upon its head. I am able, then, to substantiate Cope's assumptions as to this character, in principle if not in fact. The difference is that the plasticity, assumed by Cope for the adult, exists only in the larva, and, in case of this character, mainly (aside from exceptional stimulus) at an early age. Then, too, the stimulus is not from swimming, which Cope, though he does not state as much, doubtless has in mind, but from walking under water.

I may now make a final statement which will, I hope, seem less controversial at this point, about the actual effect of aquatic life upon the feet of adults. As before stated, I have kept a number of adults in water of varying depths for over two years after metamorphosis, and many others for lesser periods of time. These animals have been kept in glass jars or other small aquaria and have been fed upon cut liver. They have, therefore, not been so situated as to use the limbs to a great extent in moving about in search of food or the like. To some extent the results may be due to this. Yet it is significant, none the less, that these aquatic amblystomas showed noticeable degeneration of, or at least disproportionately weak development of the limbs and feet, the toes becoming rounder, more pointed at tips, etc. Even the webbing at their bases seemed to be slowly reduced under these circumstances. An examination of figures on plate V will show this, although the toes are not well shown upon all of the figures. Figure 1 still shows a very broad toe, though reduction had begun near the tips. The breadth of toe had been previously acquired by the larva, a very rapidly grown anabolic specimen. Figure 2 shows toes that were almost awl-shaped at the tips, this form having been slowly assumed at the same time that this, the

most aquatic of all my adults, was assuming its great breadth and length of tail. The posterior limbs of this same specimen, when it had reached about 19 cm. in length and had lived about six months in water, are shown in figure 7. The toes will be seen to be very short and narrow. The posterior limbs of a stronger-limbed and very typical aquatic adult are shown in figure 8. It will be noticed that the toes have here become very narrow, sharp, and cylindrical with unusually little webbing at their bases. Permanent aquatic life, then, would, in all probability, reduce, rather than develop the limbs of this species; certainly it would not develop a swimming foot. A comparison of the limbs and feet of the more aquatic or the wholly aquatic forms among the Urodela as a whole obviously substantiates this view.

As I have watched the development and modification of the limbs of this plastic species, the thought has occurred to me again and again that the phenomena were suggestive of important factors which may have cooperated, not only in the modification, degeneration, etc., of the vertebrate limb, but quite possibly in its earlier stages of formation. Of course the improbability of transmission reduces the importance of the otherwise suggestive results of use and disuse. But not so with the equally striking results of overgrowth. Excessive nutrition with these larvae seems, as it were, to overflow into all peripheral parts, quite regardless of function. It looks as if the tissues forming the central axis of the body were incapable of growing at more than a certain fixed rate, with the consequences that nutrition in excess finds lodgment where it may, in hypertrophied gills or limbs, regardless of any necessity laid upon them by function. How easily might some preamphibian, Protopterus-like ancestor, overglutted with food in some fresh-water habitat, have thus developed a fin-like appendage into the bulk if not the build of a limb. And when we add to this the fact that these same conditions of excessive feeding and overnutrition are the conditions which make metamorphosis inevitable, and that metamorphosis is essentially a random process, reducing weight and destroying the less resistant tissues of the body while tending strongly toward ossification of cartilaginous structures, it seems as if we had

the first conditions of limb-building brought very close to us. I have said that these effects of overnutrition are not to be classed with those of use and disuse as regards transmission. The reason is that they result essentially from the single primitive factor of appetite, and, surprising as it may perhaps seem, I have considerable evidence that this is hereditary.

Before leaving the posterior limb I must speak of one more variation which is, in its way, as interesting as any I have mentioned, but which is, it would seem, almost purely a phenomenon of habit, of adaptive functioning. I refer to the different manners in which the limb is used in locomotion, as well as to the different positions in which it is held when at rest. Even in breeding adults, taken at the same time and place, the contrast is most striking, especially if the animals are placed under suitable conditions, e. g. in a large vessel with very shallow water which admits of free and natural movements. Some animals extend the posterior limbs, when at rest, straight outward, at right angles to the body and with the soles of the feet nearly or quite vertical. Such positions are partially shown in figure 2, plate IV, and figure 1, plate VI, although neither of these shows the foot sufficiently vertical, the effort in the photography having been to show as much of the foot as possible. Such animals as these use the limbs in nearly this position of extension when walking; in bringing the foot forward, the knee is flexed but little, and in the backward stroke the limb is used almost like a straight lever, the foot moving through a segment of a circle. In walking on land or overcoming strong resistance the joints are flexed more and the soles are more completely planted on the substratum, but the tendency toward this awkward, straight limb is always manifest. Omitting intermediate types, which of course occur, one occasionally finds large adults which attract attention at once by an opposite use of the limbs and feet. Such specimens stand on their feet, even when at rest in the water, or at least they frequently do so, and the feet are even planted close to the body, all of the joints—hip, knee, and ankle—being very sharply flexed. The knees of such animals are, indeed, thrust upward in a most lizard-like attitude, and the attitude is quite habitual. In

walking, too, such individuals do not use the limb after the fashion of the half swimming stroke, described above, but the foot is carried almost directly forward, parallel to the body, and in the back stroke the inner toes even pass under the side of the body and of the hip girdle. The inference is natural that this more perfect use of the limb is a question of age in the adult, the adaptation being to terrestrial rather than to aquatic life, more especially an adaptation of the posterior limbs to vigorous action within a narrow burrow. This may be, to some extent, the case, for I find that the limbs of the adult are capable of fairly marked modifications of this nature after metamorphosis has taken place, provided that their situations are sufficiently peculiar, are uniform for the individual, are sufficiently prolonged, and that the animal is so fed that growth (the chief and first condition of all modification) takes place. In many cases, however, no such modification during adult life occurs. At the present writing, I am photographing a number of animals, known to me as larvae three years ago, and it is surprising to what extent even delicate features of larval limb-habit have been retained. In any case, the modifications are most striking during larval life. This is true whether we take single instances of extreme attitudinal and functional difference, or whether we notice the regular recurrence of minor differences in the case of whole groups of larvae developed under closely related yet somewhat different conditions.

As an instance of the latter I may cite again the case of the two groups of larvae, developing during the same season, in the same pond, upon the same food, but the larger number of which maintained the free-swimming habit while a considerable but smaller number rested upon or crawled about the bottom. A series of both of these types was photographed by placing the chloretoned animals on a glass plate under water. When the limbs were thrown forward they would sweep back to a natural position at about a right angle to the body, and as it happened with perfect regularity the feet of the more slender, free-swimming larvae would remain almost vertical, refusing to take any other position save as the result of much manipulation, while the feet of the robust bottom-crawlers would naturally rest at an

angle of less than 45° to the substratum. Even minor degrees of difference in body form and other characters which showed the development in greater or less measure of one or the other habit proved to be correlated, with surprising delicacy, with the special angle at which the sole of the posterior foot naturally rested on the bottom. It should not be supposed that such a rule would hold for larvae taken at random from various sources, and it does not so hold. But in the case cited the differentiating factor between these two groups had been solely their relation to the bottom. As to more conspicuous contrasts, involving, besides the angle of the foot, the flexure of all the joints of the limb, they are not usually to be found in young larvae of the first summer. But among neotenic specimens occasionally the strongest differences appear. Some individuals will show the strong "one-jointed" leg described above, others will vary from this to more and more slender limbs, held in more or less useless attitudes, sometimes actually trailing behind, not only when the animal swims freely but when it is undulating slowly along the bottom; and, finally, many of the neotenic larvae will show limbs fully adapted to walking by the strong flexure of all of the joints and the natural plantation of the soles. Such extremes as this last described occur only in larvae that have lived a long time on the bottom. I have observed the development of these different limb-habits to a considerable extent in larvae grown under my observation, but not to the fullest extent in the case of the walking limb. In the other direction, however, I have even seen the posterior limbs of a beautiful larva reduced in size and become utterly useless from no other cause than that the specimen, quite normal at first, was rapidly grown in a tall glass jar where a still stronger companion allowed it absolutely no space at all for limb exercise on the bottom. These extreme differences in the larval limbs are also not obliterated or even reduced by metamorphosis.

I have now spoken of variation and causes of variation as I have found them present and operative in the case of several external characters of the species. These variations, or some of them, are sufficiently striking in amount, although my chief in-

terest has been in tracing them to their causes, which prove to be so simple and uniform in character.

VARIATIONS CAUSED BY CANNIBALISM

I now wish to speak of an instance of variation in this species which affects not one organ only, but many, if not all the organs of the body, and which would be interesting for its amount alone, even if its cause were unknown. I am able, however, after much search and experiment, to demonstrate its cause, and thus to confirm and cast much light upon the variations discussed hitherto. I have already referred in some sense to this variation, in that I included it in the general estimates of total variation at the beginning of the paper, and in that the adult profile in figure 3, plate III, is to be classed partially with animals now to be discussed. But the type now to be spoken of has not previously been considered. I will again introduce it, not by measurements and statistics, but by a direct reference to plates VII, VIII, and IX. Figures 1 and 2, plate VII, show profile and dorsal views of a remarkable larva (unfortunately not very well preserved, having been rolled in a cloth), which I secured several years ago. Twelve other specimens secured from the same source in the same season resembled this specimen in varying degree, two or three being nearly identical. I had no idea at that time of the rarity of such specimens; but since then I have tried in vain to duplicate them in all points of peculiarity. A glance at the figures will show the remarkable character of the specimen, especially when compared with figure 3, which represents a typical larva of the same length and somewhat similar preservation. I need hardly call attention to the prodigious width of the head, or to the distance between the orbits of the eyes (still greater, proportionately, in some other specimens than in the one figured), or to the length of the head, one-half greater than that of many normal larvae of the same total length. It is more necessary to point out the fact that the deviation here from the normal type of *amblystoma* is in reality greater than a casual glance would indicate, the skeletal proportions being modified much more than the

external appearance. Thus the width of the head is not due, as in most broad-headed specimens, to the development of the parotid glands; on the contrary, in this type of larva these structures are non-developed, the width being due to an enormous extension of the whole buccal and branchial apparatus. The width of the gape essentially equals the width of the head. How singular this distortion of proportions is becomes clear when we estimate what the width of head in figure 2 would be were the parotids and posterior portion of the head developed laterally until they exceeded the gape of the mouth proportionately as much as they do in certain small-mouthed but wide-headed individuals of the type of figure 1, plate II. The width of the head in this hypothetical case would equal one-fourth the entire length of the animal. Not that I would suggest any such carrying out of proportion as possible; it is not, as the analysis of the development of the form will show. But such comparisons serve to show, better than simple dimensions, how extremely aberrant the type is. Most obvious and striking of all the peculiar external characters, at least to one familiar with the species or even the family, is the singular profile. It is not exaggerated nor distorted in figure 1, and it is also neither accidental nor pathological. Yet one may handle hundreds or even thousands of the larvae of *A. tigrinum* without even the suggestion of such a type. Comparison should be made with the normal profiles on plate I, also figure 3, plate II, and figure 5, plate III. The profiles of the adults on plate III are also instructive, figure 3 only being related strongly to the larval type we are discussing. A comparison with the outline profiles given by Cope for nearly the whole genus is also instructive. Only in the case of the one-specimen species, *A. copeanum* (which for one who understands *tigrinum* is almost certainly a variety, and may obviously be related to the type which I am describing) shows a profile resembling, in some degree, the one I figure. In the closely related genus, *Chondrotus*, only the one species, *C. tenebrosus* (like *tigrinum*, very large) seems, according to Cope's figures of both larva and adult, to possess a dished profile. Otherwise such profiles are very uncommon throughout the entire Urodela. Only some of the lower and permanently aquatic gen-

era, like *Cryptobranchus* and *Necturus*, display somewhat similar outlines.

It was partially this resemblance of the profile, and indeed of the whole head, to some of the lower types, together with such peculiarities as extreme resistance to metamorphosis, which led me in my article on metamorphosis into the convenient and classic error of ascribing this variation to reversion. Such larvae seemed to me to represent a more primitive and perhaps perenibranchiate ancestor. Had I, at that time, worked out the causes of such other morphological developments as I have recorded in this paper, I might soon perhaps have gathered a clue to the secret of this special form. As it was I found it slow work to do so.

Gradually, however, I accumulated a few data. *First*, the variation was decidedly uncommon. *Second*, when present, it was not by itself, but only in small numbers among a great many other ordinary individuals. So few were the specimens that it seemed the form could hardly be strongly hereditary. A single female deposits from six or seven hundred to at least fourteen hundred eggs. The whole stock of larvae in an ordinary pond represents but a few such depositions. If hereditary, therefore, one should find every third, fifth, or tenth individual, say, of this type. *Third*, the type existed not only in its extreme development, but showed combination with certain other characters as well as transition forms. Most of the scattered specimens secured through several years were of this nature, one of which is shown in figure 1, plate IX. *Fourth*, the individuals showed very variable, yet always singular habits. Many absolutely refused to eat liver or raw meat, something which no healthy and hungry larva had persisted in before. Others would swallow meat in pieces of prodigious size. Nearly all of the specimens secured were very indolent and tame, yet one foiled my best attempts at measurement, because no sooner did I approach its head with compass point or other instrument, than it snapped at the same most viciously, while out of hundreds of common larvae so approached not one ever offered such a response. *Fifth*, so far as I could judge, the larvae of this type were only present in rather clear water, not in the muddy ponds which were the commoner

breeding places of the species in my vicinity. *Sixth*, among hundreds of larvae raised by me this type never appeared, with the possible exception of a single cistern-grown specimen. This individual did show many of the characters of the broad-heads and was equally vicious, laying hold of a stick with which I gently touched its tail to see if it were dead—so long did it remain unmoved upon the bottom—with a violence utterly unamblystoma-like. *Seventh*, specimens of this type and even transitional forms approaching it only were always larger than the other larvae of the same year accompanying them, sometimes very much larger. *Eighth*, despite this rapid growth many of these specimens, especially the more extreme ones, showed unmistakable signs of undernutrition. Several, indeed, were more emaciated than any other larvae I had ever taken under natural conditions. Not only were the bodies shrunken, but the back-fins had the form indicating semistarvation, and the very small gills were, as my experiments at this time were demonstrating conclusively, also the products of undernutrition. Only among the transition types did certain individuals appear well nourished, large gilled, etc., such as figure 1, plate IX. Even these were in the decided minority.

These last facts, rapid growth and large size, together with all the signs of undernutrition and even starvation, would have seemed too impossible for belief had not the age, etc., of the specimens been positively known to me. They offered, however, no clue to explanation. Certain of the other facts, however, did suggest to me the possibility that the form was due to some special habit of feeding, possibly to the habit of cannibalism. I tried the effect of feeding certain larvae upon very large pieces of meat, but the larvae either refused the food or killed themselves in swallowing it, or, more frequently, were thrown into early metamorphosis by the irregular nutrition.

Not until June, 1903, did I secure more adequate material and further evidence as to the nature of the variation. At the early cleaning of the reservoir, on the 15th of June, I discovered that the number of young amblystomas present was several-fold the usual content of the place, probably five thousand were present, and among the fifteen hundred which I secured of the largest

there were about fifty superb young broad-heads, such as those shown in figures 1, 3, 4, and 5, plate VIII. About one hundred of the remainder were of similar type, though of smaller size, or represented transitions between the common larva and the broad-heads. Some of these transition specimens are shown in figures 6, 7, and 8, plate IX. The entire remainder of the larvae, although varying in size from 5 to 11 or 12 cm., were very uniform in type. The muzzles were rather broad, but the head of only normal width. All of the specimens had evidently lived upon the bottom, feeding upon insect larvae. One of the largest of the normal larvae is shown in figure 6, plate VIII; with this should be compared, not only the broad-heads, but figure 2 of the same plate, which represents a free-swimming and somewhat better fed specimen from an adjoining pond. The proportions of these broad-heads were sufficiently remarkable, especially for larvae which could hardly be more than eight weeks old; and the circumstances of their development, together with observations made at the time of their capture or soon afterward, established almost beyond a doubt the cause of their singular development, viz., cannibalism. The overstocking of the reservoir, the lack of the ordinary and adequate food supply, leaving the animals crowded together upon the bottom, the clear water allowing them to see and thus more readily attack each other, were obviously favoring circumstances. Then, too, in the course of an hour's observation after the reservoir was sufficiently emptied to permit of it, I observed three cases in which a broad-head was holding or swallowing another good sized larva. Even within the pails, to which these larvae were transferred from the net, a number of broad-heads seized their companions immediately, killing themselves as well as their prey in several instances, because, swallowing being a slow process, they could not rise for air in the deoxygenated water of the pail. My aquaria, too, showed interesting results at once. Every flat-head proved a cannibal, while the ordinary larvae, as is usually the case, did not, with very rare exceptions, attack each other in the least. Ordinary larvae 10 cm. in length may, indeed, be starved to death, or more frequently into metamorphosis, without their

attacking each other, except the strong stimulus of food is introduced (earthworms, meat), when they become violently aggressive, biting each other or anything that comes to hand. Only smaller larvae, or larvae from quite different locations, or, still more, larvae differing much in size, are incompatible as companions. But not so these broad-mouths. Among other dispositions, I placed in each of four small aquaria, four larvae of equal length. Two in each aquarium were normal, two were broad-mouths. I thought, by unlimited feeding upon the most luscious of liver, to reform the cannibals, and to be able to watch the development and metamorphosis of the two types. My hopes were soon dissipated, however, for within a few days but one of the eight cannibals was left, and several of the others had been killed.

It was curious that in every instance where two or more of the cannibals were placed at close quarters, even though other larvae were present, the result was the destruction of one or both of the cannibals, while the others frequently remained unharmed. This result is not due to the natural enmity of competitors or to a wise foresight with regard to a limited food supply, but purely to the strongly modified reactions of the cannibals themselves. While an ordinary larva instinctively avoids close contact with another, and beats the most precipitate retreat at the merest touch of cannibalistic jaws, the possessors of these weapons themselves are apparently wholly divested of this innate fear. Unless decidedly hungry they lie sluggishly at the bottom, either ignoring the chance contacts of other specimens or savagely nabbing the intruder. The violence and instantaneousness of their occasional movements contrast strongly with their sluggish inactivity between whiles. Even complete satiety does not usually check their savage attacks, provided that the proper stimulus is offered; the prey is then seized and held some time or half swallowed, to be then as quickly rejected by a sudden jerk much like the one by which it was seized. Thus it is that cannibals in close proximity almost invariably prove each other's undoing, the swallower frequently succumbing as well as the swallowed. Even when taken in the reservoir, not a few of the broad-heads were sadly bitten

or abraded, some having been, it would seem, nearly swallowed before meeting with the resistance, no doubt, of some friend who had just gone before. The ordinary specimens were mutilated much less frequently. Such facts as these give added reason why large larvae of this special type are never numerous. They also established a fair presumption as to the cause of the form: all of the broad-heads were cannibals, and of most heroic type, while even the transition specimens showed the same habit. Others did not.

Nevertheless, cannibalism might still possibly be a result, rather than the cause, of the form. I attempted to raise a number of the cannibals and semicannibals in order to see whether they would prove subject to still further modification. Although I had reared many hundreds of ordinary specimens, the broad-heads proved a wholly new problem. They killed or injured each other; they suffered at once in a way very probably due to change in depth of water, the animal losing its power of equilibrium and control of its hydrostatic apparatus, and worse still, many could not endure either running water or the sudden daily transfer from aquarium to fresh tap water. Rapidly grown larvae with delicate skins are frequently killed by this, the transfer to fresh water causing a rapid blistering of the epidermis about the gills, head, and even tail fin, until portions of the surface may look like coarsely beaten white of egg. Lastly, specimen after specimen succumbed to a disease, evidently bacterial, which has often given me great trouble, but to which the cannibals were quite unusually susceptible. So delicate, indeed, did these specimens prove that, despite my utmost efforts, all died save one. This specimen proved interesting. It was in a starvation experiment to test the susceptibility of the type to metamorphosis. Confined with another of its own type and two ordinary larvae of its own length, it killed its companion, but could not catch either of the others, both of which became extremely wary. Within ten days starvation induced metamorphosis in both of the latter, and six days later they had practically completed the process, the cannibal meanwhile showing no sign of transformation. It then consented to eat liver and become a moderate feeder.

Three weeks later it had grown from 11 to 15 cm. in length, and had decidedly begun to lose its peculiar characteristics. It changed in form more rapidly than in disposition, sluggishness and violence characterizing it up to and even after metamorphosis. But after three weeks of liver feeding the head, though still broad, was noticeably less disproportionate, and the sides had begun to slope toward the muzzle. Sixteen days later still, when metamorphosis began, at a length of 18.5 cm., the form of the head, though broad and heavy, had nearly approached that of other liver-fed larvae grown from the ordinary type. In other characters, posterior limbs, body, and tail, the specimen plainly retained results of its early specialization. This instance, which I observed with all possible care, and which I have since paralleled with a number of other cases, served to show the plasticity of the larva. The characters had been lost in about the same length of time which it had taken to develop them.

The following two seasons I exerted myself to produce the cannibalistic form experimentally. I succeeded but partially, although my success was quite sufficient to add anything that was lacking to the proof regarding the cause of the type. My most extreme results resembled closely figure 3, plate VIII, although body and tail were longer and the general cadaverous appearance greater, owing to the fact that the animals had been induced to swim much more. My experiments, however, proved interesting, the failures as well as the partial successes throwing much light on the process. The lack of success, partial or complete, was always due to one of three causes—disease, failure in inducing or maintaining cannibalism, or failure in keeping a supply of food animals of suitable size.

I first placed several hundred young larvae within an enclosure, twelve feet square, situated in the middle of a pond, with three to five feet of water. The larvae when placed in the enclosure were from 3 to 8 cm. in length. They were sparingly fed on daphnids and Chironomid larvae. Unfortunately the water in the enclosure was muddy and dark, and despite the close confinement little cannibalism followed. Now and then, however, an animal would acquire the habit, take a sudden leap forward in growth,

and show the beginnings of cannibalistic development. But relapse was almost certain to follow, a relapse not into slow growth again, but into metamorphosis. The mere beginnings of cannibalism do not, as does its fuller development, predispose the animal to the retention of the branchiate type. One of these results of perhaps a week of cannibalism is shown as figure 4, plate IX, figure 5 showing the form and the maximum size of the ordinary larvae from which figure 4 was produced. It will be noticed that the anterior part of the head has undergone a considerable lateral expansion. Just such larvae as figure 4 frequently occur among ordinary larvae in ponds, and, although not surprising, are instantly recognizable. They are undoubtedly due to the same causes which produced them in my experiment.

Another trial in the same pond enclosure showed much greater results; but in this I began with young larvae (hardly more than 6 cm. in length) taken from clear water, which already showed marked beginnings in the cannibalistic habit, as well as partial assumption of the form. With the young amblystomas were also introduced in this case several hundred equally large tadpoles of *Rana*. Thus launched, the results were varied. The majority of the young cannibals were slowly, and evidently with the utmost reluctance, starved out of their practice, returning to normal feeding and normal form. A very few developed into transitional types, becoming several times larger than the ordinary run but evidently carrying on the cannibalistic mode of life in a desultory fashion. The head of one of these is shown in figure 3, plate IX. Only a half dozen of the incipient broad-heads stanchly maintained their mode of life despite the muddy water. Their development was remarkable. Their growth was astonishingly rapid; in a few weeks they were double the length and many-fold the bulk of their mates, which were of equal size when the experiment began. Their heads assumed nearly, though not quite the extreme of type. Most interesting of all was their steadily developing appearance of leanness, well-nigh of emaciation, with gills diminutive and back fins very low, conditions which, as I have said, indicate semistarvation in ordinary larvae. By the time, however, that the largest of these cannibals had

reached 18 cm. in length, a change began to appear. They continued to feed as before, and had, indeed, learned to haunt the corners of the large box for the few remaining frog tadpoles, now grown very large; both these and the other amblystomas were taken. But from this point on, the whole development changed and progressed again toward the normal type. The body grew more and the head less; the parotids expanded and the heads became full-cheeked; and, strangest of all, though the food had not changed, save that it was now much more scarce, the animals soon became excessively full bodied, large gilled, and fat. The results of early cannibalism were not lost entirely; even after metamorphosis, the adults were conspicuous for heavier lower jaws and broader heads than any others of the season's development. The loss of the early acquired characters was, however, very rapid and very conspicuous. Watching the process from day to day, too, the cause became perfectly clear. The peculiar cannibal type developed progressively just so long as the food animals were disproportionately large and great difficulty occurred in the swallowing. I had thought that possibly the nature of the food (flesh of same species or of other Amphibia) might be a contributing cause. This experiment and others still more conclusive showed that it is not. The cause of the general leanness, too, of the reduction of the parotids, and, as we shall see, of other parts of the body, seems solely due to the struggle between the organs of the body, much nourishment being drafted away to produce the hypertrophy of buccal and branchial apparatus as well as body length, digestive tract, etc., that other organs are, of necessity, greatly reduced. So soon as the excessive labor of swallowing ceases, assimilation rapidly tends to a more normal distribution, and the ordinary type tends to be partially restored. Such observations as these explain fully such types of larvae as figure 1 on plate IX. This is a neotenic larva, undoubtedly a cannibal during its first season. During its second season, it fed upon small larvae or a mixed diet, and thus lost a portion of its peculiar characters, acquiring its large gills, etc. I have tested this explanation by examining stomachs of such specimens. First-year larvae usually live on a remarkably uni-

form diet, frequently upon a single food organism. Only little by little do older individuals acquire more varied habits, their stomachs, in rare instances, yielding various Entomostraca, insect larvae from *Chironomus* up to the dragon fly, adult water insects, and fair-sized younger larvae of their own species.

Of all the points in the foregoing description, the most doubtful one may appear to be the assumption that young amblystomas, which normally feed upon organisms no larger than daphnids, should so readily take up the practice of swallowing animals nearly as large as themselves. The readiness with which they do so does seem to vary very much with different individuals showing no other differences than slight variations in aggressiveness of disposition. I tried many single specimens, isolated in small aquaria in the laboratory, beginning with them at 6 to 8 cm. in length and using either smaller larvae of their own species or frog and toad tadpoles to induce them to change their diet. Some refused entirely; some enjoyed a cannibalistic meal or two, only to relapse into starvation rather than attempt another; some made splendid attempts, but failing at first, forever lost their courage. Only a few possessed the true heroic fire, dauntless, no matter how great the difficulties or how frequent the failure. I have seen such a larva return continuously, aside from brief periods of rest, to the task of swallowing a tadpole nearly as large as itself, for twenty-four hours, working away for a few minutes to an hour or more at each attempt. If the tadpole was killed before being swallowed, no further notice was taken of it; but as soon as another was supplied it was attacked with as much spirit as before. Such observations supply the full rationale of the variation. One can fairly see the head-expansion within a single day; and no wonder, when the whole masticatory and respiratory framework is stretched as if it were rubber and held in this position for the utmost time that the animal can endure, and then, after recuperation, the whole thing is repeated again and again. With so plastic an animal as this larva, adaptive development follows inevitably under such circumstances, and the whole bulk of nutrition is drained off to the head and adjoining parts. The meaning, too, of the starved or even emaciated con-

dition of these larvae becomes clear. So much energy is absorbed in the heroic efforts of ingestion, so much matter is required for the building up of the anterior part of the body and of the trunk, which, to a degree, must keep pace with it, that every accessory organ is reduced and all the organs are as lean as possible.

The starvation affects mostly the gills and the limbs. Perhaps actual weight constitutes the best test of these relations, and I have weighed the limbs and different portions of the body upon delicate balances to ascertain just what the proportions might be. Thus the total weight of the four limbs of an 11 cm. cannibal (preserved in formalin) is but 0.20 gr., while the limbs of a delicate daphnid-feeder of same length weigh 0.58 gr. These figures are not extreme, for by seeking among a small number of specimens for a stronger limbed individual of equal length (also a daphnid feeder) I readily find one whose limbs weigh 0.90 gr. Nor is this reduction of the limbs of the cannibal merely a matter of general emaciation, as is shown by the ratio of the weight of the limbs to the entire weight of the animal. The weight of the limbs of the above young cannibal constituted a little less than one sixty-fourth of its entire weight, while with the second specimen they constituted one twenty-first, and in the third somewhat less than one-sixteenth. Even more striking would have been the discrepant relations had I chosen the posterior limbs alone for comparison. In all ordinary larvae the posterior limbs are larger and heavier than are the anterior. Not so with these young cannibals. So strongly is the development shifted to the anterior end in these animals that the relative sizes of the limbs are quite reversed; the anterior limbs, though very slender, remain about normal in length, while the posterior are reduced in both length and girth. To illustrate thus these more extreme contrasts: the weight of the posterior limbs of the above young cannibal (0.09 gr.) was contained in the total weight nearly one hundred and forty-three times, while in the heavier-limbed pond larvae of the same length, the weight of the posterior limbs (0.50 gr.) entered into the total weight a little over twenty-nine times.

Functionally, too, these contrasting developments become evident, and even absurdly so, when the animals are placed side by side out of water. Unless glutted with food, the ordinary larva can crawl considerably, but not so the cannibal. When I dipped such animals out of their aquaria with a concave sieve to display their contrasting developments, their ludicrously different achievements in locomotion never failed of effect. The ordinary larvae could crawl about considerably in the sieve, and, if strong-limbed or starved a little to reduce weight of the body, would sometimes crawl quite out. But the most desperate efforts of the cannibal could never raise the anterior end of its body well from the support, and it soon found itself pinned down, as it were, with its head in the lowest part of the sieve, all efforts at locomotion serving but to move the posterior portion of the body round and round the stationary head.

I have spoken of the fact that incipient cannibals may be induced to return to ordinary feeding. It is interesting to note, however, that this is, in many instances, extremely difficult, even with larvae no more than 6 cm. long. I have taken such larvae from clear water and found them obstinately feeding upon their companions, even though the water of their aquaria was alive with daphnids, which constitute the most natural food of the species at all ages. In no other single instance have I found amblystomas of any age refusing daphnids as food, even when they were several years old and had never before seen an entomostracan. During two seasons I placed a large number of very young larvae in a pond, well stocked with ordinary food organisms, but in which the conditions were not favorable to cannibalism. Yet even here a few of the larvae which showed but a trace of the broad-headed type when liberated persisted in their development, and were taken from time to time during the summer in the most deplorable state of cannibalistic emaciation, so delicate withal that I could scarcely keep them alive for twenty-four hours.

Not less surprising than this persistence is the obvious psychic or nervous change that takes place almost from the start in the young larvae which has become well launched on its career. Or-

dinary larvae are rather slow in taking food from the bottom—earthworms, meat, or insect larvae. They react mainly to tactile stimuli, although strong odor (taste?) sets them to slowly backing up and rooting about with the muzzle, finally snapping in case a moving object touches the jaws. About their manner of taking free-swimming prey, daphnids, water-boatmen, etc., there is also nothing striking except under such circumstances as I have described. The organisms are snapped up either when they touch the jaws or when they come into suitable range of vision. Larvae fed from the forceps do frequently learn to see the meat coming, and rise a little distance for it. Some of them even recognize the approach of a person several feet away. But with baby cannibals the capture of living food has evidently been a much more stimulating experience, and the sight of moving prey at a distance of several inches excites them strongly. I placed several young cannibals, hardly more than 6 cm. long, in large battery jars of clear water. One at a time I introduced some nearly grown tadpoles of *Chorophilus*. These latter are especially active, and even when not swimming are incessantly vibrating their tails. Such tail-wagglings were more than the calmest young broad-head could stand. Some started in immediate pursuit, though approaching cautiously for the final grab. Others, however, when a *Chorophilus* chanced within their distant range of vision, across the bottom of the jar, went through the most astonishing mimicry of the behavior of a larger carnivore. First, the animal rose slightly on its limbs, swaying forward; then a forward stride or two, then a pause, followed by another slow forward movement. If at this stage the *Chorophilus* again vibrated its tail, as it was most likely to do, an actual tremor could plainly be seen to pass over the body of the cannibal, and it again slid forward more rapidly. So closely did this whole process simulate the movements of a cat stalking a bird, it seemed impossible to believe the movements observed were but the result of an incipient, acquired habit of but a few weeks' duration, and not really natural to the species or to many of its congeners. Moreover, most of the stealthy stalking movements ended in failure. The actual captures resulted far more fre-

quently from chance head-on collisions, resulting from the *Chorophilus*' own movements.

Last of all, before leaving this type of variation, I will add that the modifications in external characters of which I have spoken and which are shown in the plates are no more important than are other and inner modifications. Reserving for a fuller presentation the details of most modifications, I will state a few of them simply. That muscles are elongated and otherwise modified is obvious. Most of them are not proportionately developed in breadth. The lower jaw becomes disproportionately heavy. The gill arches are not only greatly elongated but the gill rakers become separated by nearly twice the interval which separates those of the ordinary larva. Even the brain, easily visible through the soft palate, which is especially transparent in the cannibals, is modified. Instead of growing with the growth of the head, it is noticeably smaller, not only relatively but absolutely, and of a less compact and more piscine type. Its position, too, with regard to certain portions of the skull, is surprisingly changed, the change being apparently due to the development of the anterior part of the skull itself. Thus in a normal larva of about 10 cm. the brain reaches to within 5 mm. of the snout, while in a cannibal of the same length the distance may be increased to nearly or quite 8 mm. And if, in place of this absolute displacement we observe the displacement relative to certain other organs the modification becomes much more conspicuous, e. g. the cerebral hemispheres in the normal larva extend well forward between the lateral combs of the palatine teeth. If the head were sectioned just posterior to the palatine teeth, the line of section would pass almost or exactly between the bases of the cerebral hemispheres and the optic lobes. On the other hand, in a cannibal the brain does not extend between the palatine teeth at all, and a section removing the anterior portion of the head might include all of the palatine teeth and something more without touching the brain. This relative displacement is, as I have indicated, due to a modification of all the parts and not to a modification and displacement of any one.

This brings me to a brief discussion of the most significant bit of variation which I have found in the species, viz., the modification of the teeth, more especially of the palatine teeth. It is due, as I have demonstrated, solely to this habit of the capture of large prey. I regret not being able at the present time to publish drawings sufficiently accurate to show the exact amount and nature of the variation. But the best judges to whom I have shown the specimens pronounce the variation to be at least of generic value. And I question whether, in the entire family Amblystomidae, a more aberrant and remarkable dentition can be found. Cope speaks of the teeth of the normal larva as constituting the "larval arch," and this describes fairly well the naked-eye appearance of the delicate series of almost indistinguishable points forming little more than a white line, a little removed from, and running parallel to the series of the teeth in the upper jaw. A closer scrutiny, however, reveals more than this. In all larvae that I have examined the arch proves to be divided, or at least constricted, at three points, at its apex and laterally at two points nearly opposite the inner nares. These divisions, although hardly noticeable in young larvae are, I think, always visible under a lens. They divide the palatal teeth into four combs. A good lens, moreover, shows that these combs differ in width, the posterior being composed of a single series of teeth, although not always arranged in a perfect line; while the anterior combs, of about the same length, are composed of more irregularly set teeth, the number making up the breadth of the comb varying from one to three. As already indicated, the size of these teeth is very small, they being hardly, if at all, visible to the naked eye; and to this should be added the fact that the palatal ridges upon which they are situated are also very slight. The entire structure projects but little from the soft palate itself, and, in looking straight into the mouth is, of course, wholly concealed by the downward projection of the upper lip and jaw.

In the young cannibal, even of but 10 cm., all these features are changed. An hypertrophy and specialization have taken place that are prodigious. The teeth no longer even suggest the word "arch," for the separation of the four areas is complete, a

considerable interval often intervening, especially between the two anterior groups. The teeth can no longer be described as forming "combs," but are now in broad ovate "*brushes*." Even the posterior groups which in the normal larva were arranged in an almost perfect series of but one tooth in width, are now arranged in a brush in such a manner that straight rows of teeth run diagonally across the brush; and the middle rows show four teeth each, and wide apart. In the anterior brushes the teeth are also arranged in regular diagonal rows and show at least six teeth to some of the rows. Most conspicuous of all is the extent to which the two anterior groups of these palatine teeth, and especially the structures which bear them, come to project downward into the mouth. The posterior brushes remain more nearly at their old level, but the anterior brushes project downward—not only the teeth, but the supporting structure—until there is actually a constriction about the bases of the entire structure as if it were being separated off from the palate upon which it is borne. So great is this hypertrophy of teeth and tooth-bearing structure that in looking straight into the animal's mouth—the line of vision passing the upper jaw straight to the throat—not only the teeth but even the pad which bears them projects visibly below the upper jaw, and bears on each side a formidable array of lance-pointed teeth. As one looks into the mouth, six or seven such teeth show on each side. As to the actual change in the size of the teeth, measurements are difficult, but a fair idea is gained by the following: before me, as I write, lie the upper jaws of two 10 cm. larvae, a daphnid-feeder and a cannibal. In the former I can not see the separate teeth, even under water, with the naked eye. With a Hastings lens of fifteen diameters I can see most of them on one side; to count the exact number is difficult; I require to turn the head, and to light each side very favorably before I can see even the majority of them. In the cannibal head I can see many of the separate teeth with the naked eye at a distance of two feet, and all of them, so far as they project outwardly in plain view, by closer scrutiny. I judge, then, that these teeth are, in size and free projection, not less than thirty times as large as the others.

All that I have said applies to the teeth of larvae like the cannibals on plate VIII, or several centimeters smaller. I have not been able adequately to follow all the phases of later development, but some further facts are interesting. Often no further development takes place, but even a retrogression begins. What becomes of these cannibal teeth when the habit is finally quite given up I have not fully determined. I think they are probably shed entirely. In several older cannibalistic individuals, including the one on plate VII, and the large transition type on plate IX, a curious change has taken place. The heavy downward projecting ridges or pads that bore these teeth remain very prominent; but they are quite destitute of teeth, except along their inner borders, where a few very large teeth point almost directly toward the throat. Possibly this loss may be connected with a temporary assumption of some other habit of feeding. Some of the specimens had fed, at least partially, upon snails. So far as I have examined adults resulting from cannibals or semicannibals, I find the palatine teeth are shed entirely. The ridges which bore them are also reduced, although remaining many times more prominent than in ordinary adults. In larvae which are full cannibals but which have reached a size somewhat greater than those on plate VIII, there seems to be no further hypertrophy in the actual size of the teeth, but differentiation and adaptation continue in other ways. Thus the anterior brushes come to exceed still more the posterior, rendering these latter sometimes relatively insignificant. And at the same time they change their angle of projection; the brush comes to face, not directly downward, but downward and backward, so that nearly all of the palatine teeth point more or less toward the throat.

It seems to me very interesting to note these rapid, progressive variations of so strikingly adaptive a nature. And it is still more interesting because the species shows so many other variations which are but partially or not at all adaptive. Contrast for a moment these adaptive variations in form and habit with variations in the time of metamorphosis. It is true that metamorphosis has been supposed to be the very quintessence of adaptation. But my study of it in this species shows it to be here of the

most opposite nature,—an accident rather than an adaptation. It is subject to the widest fluctuations, yet with but a minimum of advantage resulting therefrom either to the individual or to the species. Evidently the power of adaptive response along one line in a species in no way implies such a power along other lines. Adaptive and arbitrary features coexist side by side.

Before leaving the discussion of the cannibalistic type, I will add a few more facts concerning it. First, I may state that while there is little hypertrophy in the teeth of the upper jaw proper, those of the lower jaw, including those of the splenials, are very greatly enlarged, although the change does not equal that in the palatines. Second, it is interesting to note that, so far as my observation has yet gone, it seems that these cannibalistic individuals develop almost exclusively into males. Among the specimens that I have metamorphosed there has occurred but a single female. And among perhaps a half score of wild adults that I have seen, which appeared to me certainly to have resulted from cannibals or semicannibals, not one has been a female. More observations are, however, necessary, especially when the further fact is taken into consideration that, in the writer's vicinity at least, males seem to preponderate as to both numbers and size. Among the sexually mature adults that I have collected, every one of nearly a score of animals which have approached or exceeded the limit recorded for adults of the species (11 inches) has been a male. They outweigh as well as outmeasure the females.

Finally, I will add that there may possibly be found similar facts of dental variation, due to the same cause, in another species of salamander. At least the careful examination of its habits and teeth in the larval stage would be highly interesting. I refer to *Chondrotus tenebrosus*, a giant of its genus, parallel in this respect to *A. tigrinum*. Cope records some interesting facts of the larvae of this species. Among others, "The teeth of the larva are stronger than in the adult. They are compressed, double-edged, and acute, having thus a dagger-shape. They can inflict a severe bite. . . I took from the stomach of one of them a larva of its own species of one-third its size." Cope does not seem to have

examined a great number of larvae. Did he by chance hit upon larvae which had acquired a cannibal-dentition? Or is such a dentition really universal in this species, coincident with the habit, or instinct, of feeding upon large prey? In either case, the facts will prove very suggestive when compared with the instance of the acquired character in *A. tigrinum*.

SUMMARY AND CONCLUSION

From the foregoing presentation certain generalizations become almost obvious, yet are worth restating. The first and chief is the one with which we started, viz., the variations of *A. tigrinum* are, primarily, acquired variations of the larva. By acquired, we mean that they are the direct or indirect result of environment during the larval lifetime, or, more properly speaking, during the growing period of the branchiate form. The only exceptions are certain sexual differences, which are not strongly marked in this species, together with a few other modifications of adult structure during later life. These latter are not unimportant, but are mainly due to conditions that are extreme or positively unnatural to the species. The capacity for variation of the young growing branchiate, however, is eminently natural, being called into play by changes in environment such as the species readily and instinctively accepts.

A second general fact, strongly apparent, is the preponderant rôle played by nutrition in the production of variations. Seldom, indeed, is this factor negligible. The more intimate one becomes through experiment and observation with the life of the species, the more varied and unique become the results which are seen to come from even slight nutritive differences. Even characters which seem strongly adaptive and suggestive of some peculiar or excessive mode of functioning, such as flattened and bordered toes, excessively robust limbs, and very large gills, prove to have, not only as a necessary condition but as a chief or almost exclusive cause, an excess of nutrition. Moreover, a sudden excess or deficiency of nutrition may easily determine, in several different ways, the whole course of development of the animal, modifying

both its general form and the details of its structure, directly and indirectly, as by some new type of locomotion which is forced upon the animal.

A third general fact of hardly less prominence is the frequency, the variety, and the extent of functional variations. Use and disuse, in varying modes, degrees, and successions, play strange pranks with this species. Although the direct effects of nutrition are, on the whole, more obvious and perhaps more general as sources of modification, yet such extreme results as "cannibalistic teeth" might lead one to consider functional variation as the chief cause of the polymorphism of the species. I am unacquainted with any instance in which such variation is carried farther than in the larvae of this species. Here in this general principle it is evident that one of the two chief assumptions of Baird and Cope is, in principle, fully justified, although it is a curious comment on the habit of easy *a priori* interpretation to find that scarcely one of their applications of the principle holds good.

A fourth point worthy of special emphasis is this: specific characters, in species which vary as *A. tigrinum* varies, are, after all, strongly determined by environing conditions. There is nothing new in this. But the study of this species seems to me to lend it new weight and confirmation. If the broad head and large teeth of the cannibal are acquired characters—and they conform to the definition of such—what are the narrow head and smaller teeth of the customary daphnid-feeder? Are these specific and congenital characters? They are more frequent, more "typical" in the species; but I am forced to conclude that they are so chiefly because daphnids are numerous and constitute a convenient and stimulating food. And the same may be said of nearly all specific characters: so readily are they modified by a changed environment that we must conclude they are, in reality, equally determined even by an unchanged environment. Congenital tendencies in such species are not definitely specific, but only indefinitely specific. In this species, indeed, they are not always even definitely generic.

Lastly, the foregoing presentation raises the general question: What is the significance for evolution of such variations as *A. tigrinum* shows us? Are such variations the stuff of which species are made? This may well be doubted. Not all species, assuredly, arise thus. Did they do so, they would be as temporary as the temporary local conditions of environment that produced them. They would vary much more than they do; and instead of the broad facts of geographical variation we should find, in the most limited ranges, a chaos now of minor, now of major differences, all determined by the most purely local conditions. It is, indeed, evident that, with forms as plastic as *A. tigrinum*, the formation of a new species, in the ordinary sense of the word, must imply a cessation of variation rather than its continuance. Otherwise the new form will be as plastic as the old and will be reduced by the environment to a common level, or a common chaos, with it. The only way that such variation as that shown by the species here discussed could be productive in species formation would be through the control of environment itself. Thoroughgoing, broad, and general differences in environment would readily stamp the individuals produced under them with a sufficiently peculiar character. The result would be an "ontogenetic" species. That such species exist, both in nature and in our catalogues, seems almost certain. But to discover them and test their character fully will require experimental studies along lines which I hope this article may, to some extent, suggest. If botanists are discovering that the only test of a species is in the transplanting, it seems not improbable that the zoologist must soon admit that the final test of many species must lie at least in the rearing, and that, too, under controlled conditions.

But even the discovery and proper classification of ontogenetic forms is of less importance than the tracing of their relationship to forms that are incipiently phylogenetic. The genus *Amblystoma* is rich in material for such study, both within as well as without the species *A. tigrinum*.

In closing, I wish to thank Dr. H. L. Shantz and Messrs. R. M. Ragle and M. G. Hall for the service they have rendered me in securing very valuable material from Colorado. And finally, I

wish to express the fullest measure of thanks to Dean Henry B. Ward who, both before and since my connection with his department, has not only rendered me every assistance possible, but whose appreciative encouragement has been the necessary stimulus without which this work might never have been completed.

EXPLANATION OF PLATES

All figures are from photographs, $\frac{2}{3}$ natural size. All are from living animals anesthetized with chlorotone, unless otherwise stated. Color patterns (to be treated elsewhere) are nearly true to the originals.

PLATE I

Fig. 1. Side view of very compact larva; form due to rapid growth with little swimming.

Fig. 2. Side view of larva shortly before metamorphosis; form due to less rapid growth.

Fig. 3. Side view of larva of typical form, due to free-swimming habit and rapid growth.

PLATE II

Fig. 1. From formalin specimen. Shows excessive development of parotid glands due to brief period of maximum nutrition. The special visibility of glandular pores due partially to state of preservation.

Fig. 2. Dorsal view of larva from same lot as fig. 1 of pl. I. Shows the short form due to growth with little locomotion, and wide head due to expansion of head by feeding on daphnids in the dark, and to moderate development of parotids.

Fig. 3. Side view of head of fig. 2.

Fig. 4. Dorsal view of slender larva, result of slow growth with swimming habit.

Fig. 5. Partial side view of fig. 4.

Fig. 6. Posterior foot of a medium to slowly-grown larva about 20 cm. in length.

Fig. 7. Posterior foot of a 25 cm. larva, very slowly grown.

Fig. 8. Posterior feet and limbs of a 20 cm. larva, very rapidly grown.

Fig. 9. Posterior foot and limb of a 27 cm. larva slowly grown.

Fig. 10. Posterior foot of 27 cm. sexually mature larva of robust and rapid growth.

Figs. 11, 12. Posterior foot of rapidly grown specimen photographed before and after metamorphosis, showing full retention of form and flattened digits.

PLATE III

Fig. 1. Slender, narrow-tailed adult resulting from a slowly grown larva.

Fig. 2. Short, broad-tailed adult resulting from rapid growth. Same as larva, fig. 1, pl. I.

Fig. 3. Long, depressed head, with great gape of mouth, resulting from cannibalism, followed by long starvation in larva. Length of entire specimen (in formalin), 23.3 cm.

Fig. 4. Very short, high-arched head of adult 23.2 cm. long.

Fig. 5. Head of larva of corresponding type, 25.4 cm. long.

PLATE IV

Fig. 1. Dorsal view of slender adult (formalin preservation) resulting from slow growth and free-swimming habit of larva. Length of specimen in life 19.7 cm.

Fig. 2. Dorsal view of adult resulting from larva on pl. II, fig. 2.

Fig. 3. Dorsal view of adult modified by continuous high feeding in water.

Fig. 4. Head showing exceptionally pointed muzzle. Result of excessive free-swimming life and daphnid feeding.

Fig. 5. Head normal, of wild adult.

Fig. 6. Posterior foot of slender adult nearly 19 cm. in length, result of rather slow growth.

Fig. 7. Posterior foot, with very slender toes, of 21 cm. adult, result of growth and metamorphosis at low temperature.

Fig. 8. Posterior foot of a robust, 19 cm. adult. Toes rendered slender by same process as with fig. 7.

Fig. 9. Posterior limb and foot of rapidly grown animal 20 cm. long.

Fig. 10. Posterior limbs and feet of a very slender adult male, 28 cm. long.

PLATE V

Fig. 1. Adult female showing broad, thick tail due to heavy feeding in water.

Fig. 2. Adult male showing broad, thin, and elongated tail due to slow growth of larva, aquatic life, and sexual maturity of adult. Formalin.

Fig. 3. Slender adult, originally with slender tail, which latter finally expanded as result of heavy feeding in water.

Fig. 4. Anterior portion of robust adult showing depression of head after long life in water.

Fig. 5. Head of same animal as fig. 3. Shows extremely truncated muzzle acquired during larval life and accentuated by aquatic life of adult.

Fig. 6. Head of same animal as fig. 2, though photographed at an earlier age. Shows the broadening of the head due to aquatic life of adult despite extremely slender body and tail.

Fig. 7. Posterior limbs and feet of same animal as fig. 2, though photographed at an earlier age. Toes small and narrow as result of aquatic life.

Fig. 8. Posterior limbs (very typical) of another adult kept long in water; toes have become narrow and cylindrical.

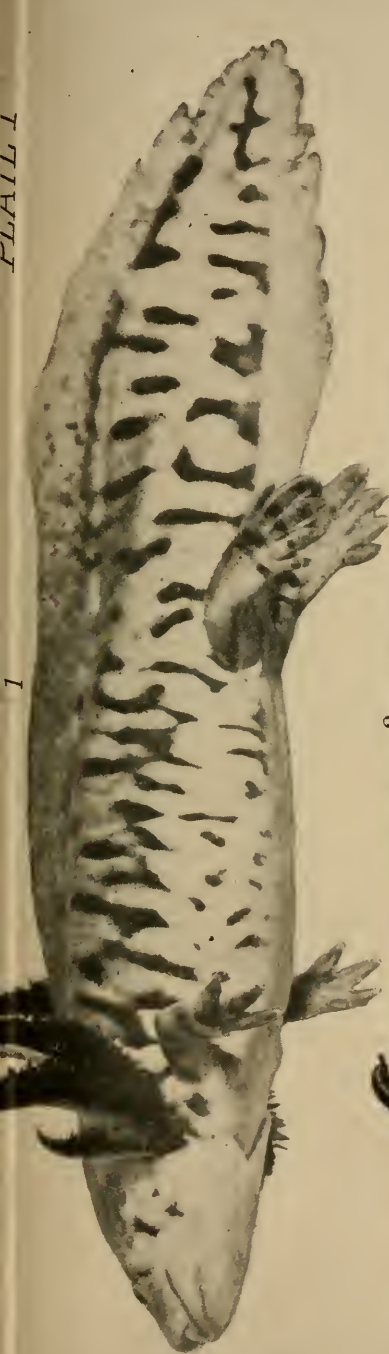

2



3







2



3



4



5

PLATE IV





PLATE VI

1

2

4

5

3



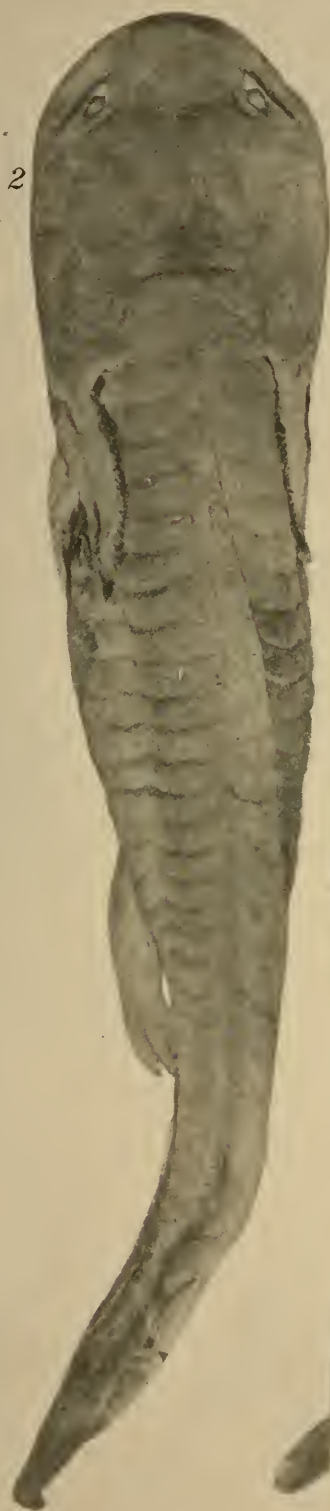

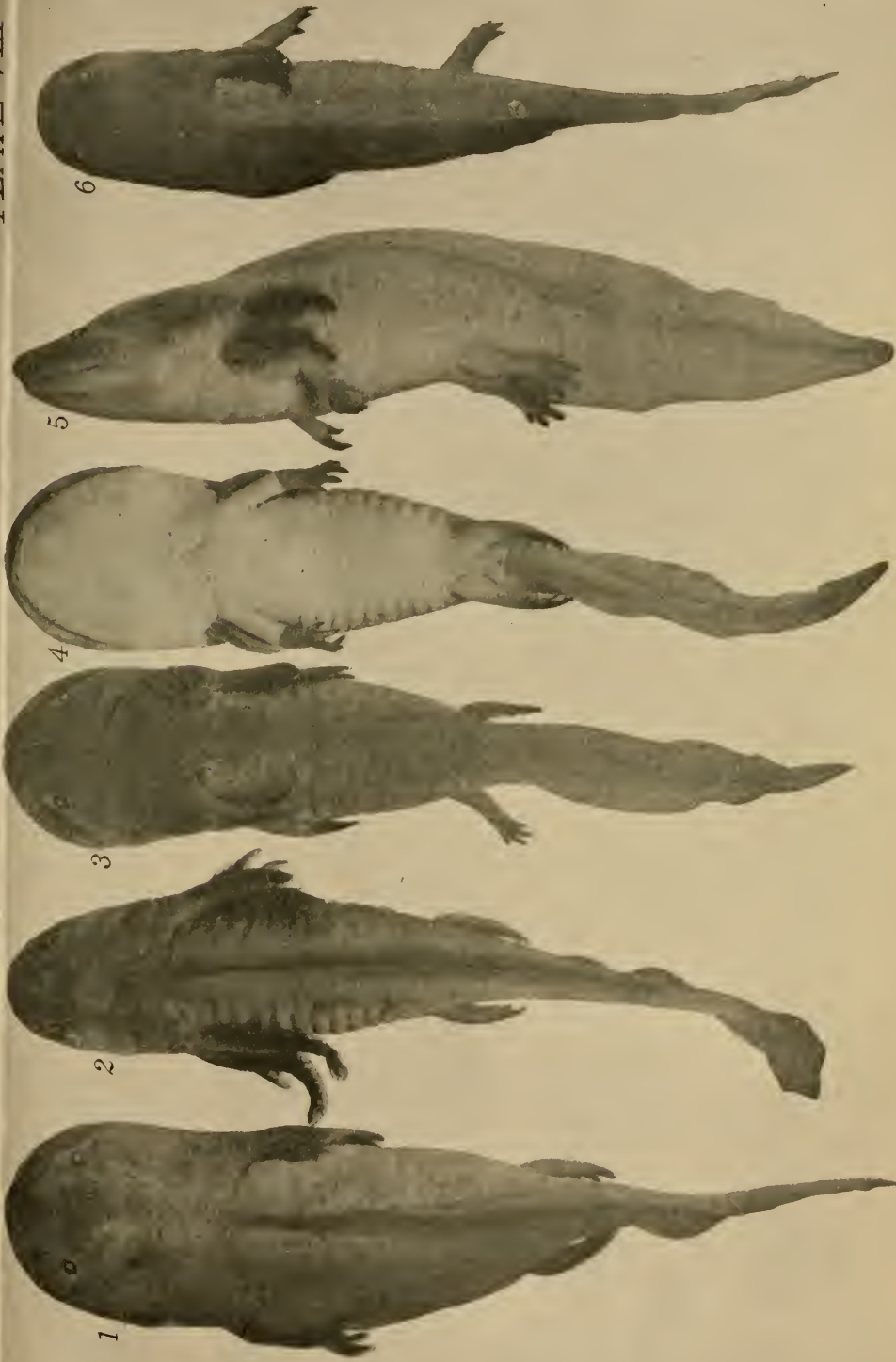

6

5

4

3

2

1

PLATE IX



PLATE VI

Fig. 1. Slender headed adult with extremely small gape of mouth. Result of larva fed excessively on daphnids, in clear water, with continuous free-swimming habit.

Fig. 2. Adult showing maximum broadening of head by aquatic life. Also corrugated dorsum of tail.

Fig. 3. Head of large larva showing truncated muzzle.

Figs. 4, 5. Heads of adults showing truncated muzzles developed during aquatic life of adults.

PLATE VII

Figs. 1, 2. Profile and dorsal views of large cannibal larva. Preserved specimen.

Fig. 3. Dorsal view of normal larva of nearly same length as the cannibal. Preserved specimen.

Fig. 4. Dorsal view of head of adult (compare profile, fig. 3, pl. III) resulting from a semicannibal. Formalin preservation.

PLATE VIII

Fig. 1. Young cannibal after full meal. Formalin.

Fig. 2. Typical larva—daphnid-feeder. Formalin.

Fig. 3. Typical young cannibal, dorsal view. Formalin.

Fig. 4. Typical young cannibal, ventral view. Formalin.

Fig. 5. Typical young cannibal, side view. Formalin.

Fig. 6. Normal larva, typical of the ordinary specimens among which the cannibals were found.

PLATE IX

Fig. 1. Broad-headed larva of transition type, i. e. a partially reformed cannibal. Formalin.

Fig. 2. Head of large wild adult assumed to result from larva like fig. 1. Formalin.

Fig. 3. Head of transition type due to partial cannibalism.

Fig. 4. Larva showing slight modification in form of head, due to brief assumption of cannibalistic habits.

Fig. 5. Slender larva of type from which fig. 4 was produced.

Fig. 6. Young cannibal showing condition of emaciation in which this type is frequently found. Formalin.

Fig. 7. Somewhat aberrant type of young cannibal. Formalin.

Fig. 8. A young transition type or semicannibal due to double habits of feeding. Formalin.



Volumes I, II, III, IV, V, and VI of UNIVERSITY STUDIES are each complete in four numbers.

Index and title-page for each volume are published separately.

A list of the papers printed in the first two volumes may be had on application.

Single numbers (excepting vol. II, no. 3) may be had for \$1.00 each.

A few copies of volumes I, II, III, IV, V, and VI, complete in numbers, are still to be had.

All communications regarding purchase or exchange should be addressed to

THE UNIVERSITY OF NEBRASKA LIBRARY

LINCOLN, NEB., U. S. A.

NJ

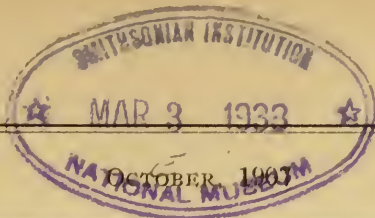

VOL. VII

No. 4

UNIVERSITY STUDIES

Published by the University of Nebraska

COMMITTEE OF PUBLICATION

- | | |
|----------------------|------------------------|
| SAMUEL AVERY | W. K. JEWETT |
| C. E. BESSEY | ALVIN SAUNDERS JOHNSON |
| F. M. FLING | L. A. SHERMAN |
| H. ALICE HOWELL | W. G. L. TAYLOR |
| T. L. BOLTON, EDITOR | |

CONTENTS

I A SYNOPSIS OF PLANT PHYLA	
<i>Charles E. Bessey</i>	275

LINCOLN NEBRASKA

UNIVERSITY STUDIES

VOL. VII

OCTOBER, 1907

No. 4

I.—*A Synopsis of Plant Phyla*

BY CHARLES E. BESSEY

This paper embodies an attempt to arrange the natural groups of plants in accordance with a theory of the evolution of the Vegetable Kingdom. It is here assumed that that theory includes the following dicta:

1. In general the lower plants came into existence first.
2. In general the higher plants sprang from the lower.
3. Higher plants are more complex than the lower.
4. Structures with many similar parts (homogeneous) are lower, those with fewer and dissimilar parts (heterogeneous) are higher.
5. Evolution is not always upward, but often it involves degradation and degeneration.
6. Evolution does not necessarily involve all organs of the plant equally in any particular period.
7. One organ of a plant may be advancing while another is retrograding.
8. Upward development is sometimes through an increase in complexity, and sometimes by a simplification of an organ or a set of organs.
9. In some cases particular structures become more simple, while the plants themselves become more complex.

10. Evolution has generally been consistent, and when a particular progression or retrogression has set in, it is persisted in to the end of the phylum.
11. Retrogression once set in usually persists, and is not followed by a progression.
12. Hysterophytic degeneration is persistent, and the hysterophytic phylum never becomes holophytic.
13. In the first stages in the development of any organ, whether upward or downward, the new structures are not as fixed as they become later, and in these earlier conditions there may be reversions to the ancestral structures, while later such reversions do not occur.
14. All plant relationships are genetic.
15. Plants are related *up and down* the genetic lines, and the system of plants to be quite natural must recognize these phyla.

Accordingly, the Vegetable Kingdom is here regarded as consisting of fourteen or fifteen well-marked great phyla, of the rank of "Branches" or "Divisions" of earlier synopses. Their general relationship to each other is crudely indicated in the chart (Plate I). Each of these phyla might be similarly divided to show the relationships of the smaller phyla (classes, orders, etc.), but that is deemed unnecessary in this case, since the multiplicity of lines and names would be confusing, rather than helpful. In this chart the areas assigned to the phyla are approximately proportional to the number of species in each, and their points of origin, also, are indicated approximately. The dotted line which comes off from the PROTOPHYCEAE in the region of the PROTOCOCCOIDEAE, indicates the probable line of connection with the Animal Kingdom. The theory maintained here is that the Vegetable Kingdom originated independently, and that the first plants were as simple as the lower MYXOPHYCEAE (if not simpler) in which the cell is of very primitive structure. From the higher MYXOPHYCEAE, with their better developed cells, the step is not a long one to the single-celled PROTOCOCCOIDEAE, and from these, by way of the *Volvocaccae*, the passage is rather easy to some of the flagellate animals. In this paper it is held that animals came from plants, following the path indicated by the dotted line, contrary to the

opinion more commonly held that plants came from animals over practically the same pathway.

In the preparation of this Synopsis the limitations of families as given in Engler and Prantl's "Natürlichen Pflanzenfamilien" have been followed in general, especially in the higher phyla. The departures from this rule occur chiefly in the ZYGOPHYCEAE where the "tribes" of desmids and diatoms have been raised to the rank of families. To the writer the added clearness and ease of comprehension of these groups of plants have proved valid reasons for these innovations. In all cases the brief descriptions which accompany the names of classes, orders and families, are intended to be suggestive of relationship, rather than differential diagnoses. The genera cited in each family are intended to help the reader more easily to recognize the type represented by the family. The citation of the "Pflanzenfamilien" (Pf.) with volume, part (abteilung), and page are for the purpose of making that great work more quickly accessible where a reference to it is desirable. In a very few cases the fifth edition of Engler's "Syllabus der Pflanzenfamilien" is cited, where new families have been proposed since the appearance of the larger work.

In this paper the whole number of families included is 636, disposed as follows:

Phylum Myxophyceae	9	Phylum Pteridophyta	13
" Protophyceae	17	" Calamophyta	4
" Zygoephyceae	21	" Lepidophyta	7
" Siphonophyceae	18	" Cycadophyta	9
" Phaeophyceae	23	" Gnetales	1
" Carpophyceae	26	" Strobilophyta	9
" Carpomyceteae	145	" Anthophyta	280
" Bryophyta	54		

It remains only to say that while the phyla are taken up in their proper sequence, as here understood, and that under these the classes and orders are arranged in accordance with the underlying theory, it has not been possible in all cases to carry out this plan in the arrangement of the families in the orders. In the great majority of orders those families which appear to be more primitive are placed at or near the beginning of the group,

while those that appear to be derivatives from these primitive families are arranged toward the end of the order. In many instances the sequence has been worked out to the author's satisfaction; in other cases, however, it has not yet been possible to make such a satisfactory disposition of the families, and here no doubt some considerable changes in the sequence will have to be made in a later edition of this Synopsis. In the meanwhile it is hoped that this prodrome may prove useful to students of systematic Botany, in directing their attention to the possibilities of the phyletic classification of plants.

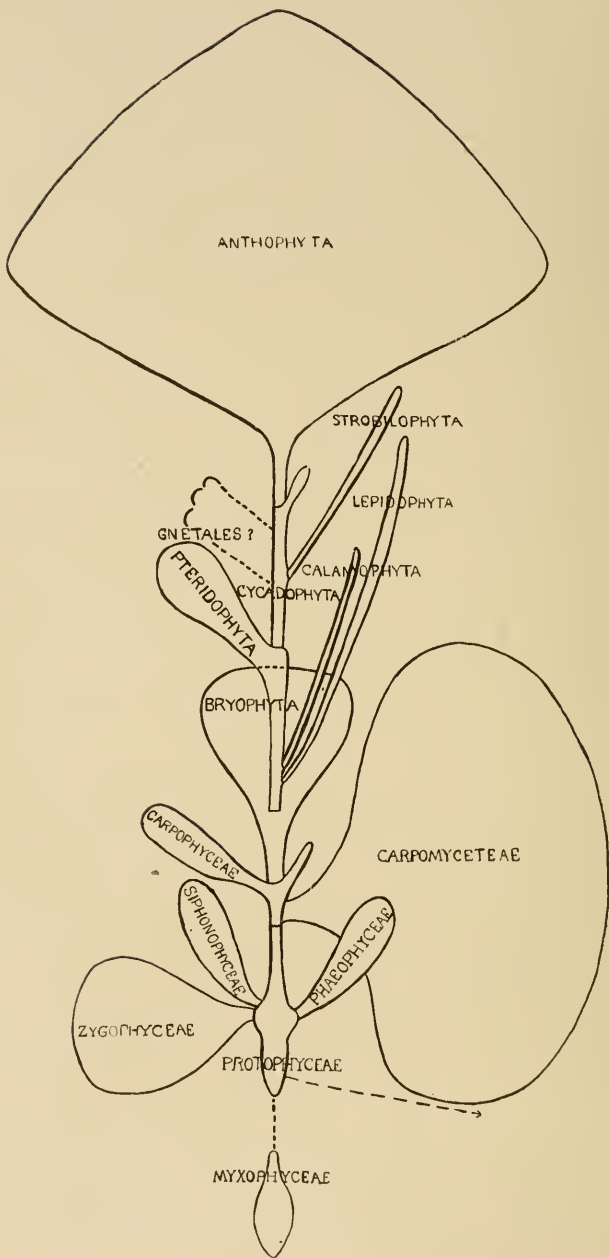

PLATE I DIAGRAM SHOWING RELATIONSHIP OF THE PHYLA.

Phylum I. **MYXOPHYCEAE.** The Slime Algae.

Single cells or threads of cells; reproducing by fission and gonidia; blue-green, brown-green, or fuliginous (with phycocyanin); cell walls usually soft and forming a gelatinous matrix by fusion. Typically freshwater plants, often occurring in warm and hot springs.

Class. 1. **ARCHIPLASTIDEAE.** Nucleus without a membrane, and not definitely outlined; no definite chromatophores.

Order **COCCOGONALES.** Plants unicellular or in colonies, commonly embedded in a gelatinous matrix, less often free floating.

Family 1. **Chroococcaceae.** Cells rounded, undifferentiated, in a matrix, or free floating; propagation by fission, rarely by gonidia. *Chroococcus*, *Glococapsa*, and *Merismopedia*. (Pf. I, 1a, 50.) One genus, *Sarcina*, contains "bacteria."

Family 2. **Chamaesiphoniaceae.** Cells more or less elongated, differentiated into base and apex, epiphytic; propagation by gonidia. *Chamaesiphon*. (Pf. I, 1a, 57.)

Order **HORMOGONALES.** Plants filamentous, simple or branched, usually enclosed in a sheath.

Family 3. **Oscillatoriaceae.** Cells in a single row, cylindrical, uniform, no heterocysts. *Oscillatoria*, *Lyngbya*, *Microcoleus*. (Pf. I, 1a, 61.) Many genera, e.g. *Beggiatoa*, *Bacillus*, *Vibrio*, etc., are colorless "bacteria."

Family 4. **Nostocaceae.** Cells in a single row, moniliform, heterocysts present. *Nostoc*, *Anabaena*, *Cylindrospermum*. (Pf. I, 1a, 70.) A few genera, e.g. *Leuconostoc*, *Micrococcus*, etc., are "bacteria."

Family 5. **Scytonemataceae.** Cells in a single row, cylindrical, heterocysts present. *Scytonema*, *Tolypothrix*. (Pf. I, 1a, 76.)

Family 6. **Rivulariaceae.** Cells in a single row, tapering, heterocysts basal; trichomes tapering from base to apex. *Calothrix*, *Rivularia*. (Pf. I, 1a, 84.)

Family 7. **Camptotrichaceae.** Cells in a single row, tapering, no heterocysts; trichomes tapering from the middle towards each end. *Camptothrix*. (Pf. I, 1a, 90.)

Family 8. **Stigonemataceae**. Cells in more than one row, heterocysts present; trichomes present. *Stigonema*, *Haplosiphon*. (Pf. I, 1a, 80.)

Class 2. HOLOPLASTIDEAE. Nucleus with a membrane, definitely outlined; chromatophores differentiated.

Order GLAUCOCYSTALES. Plants unicellular or in colonies, dividing in one plane only.

Family 9. **Glaucocystaceae**. With the characters of the order. *Glaucocystis*. (De Toni, V, 693.)

Phylum II. **PROTOPHYCEAE**. The Simple Algae.

Single cells or threads of cells, rarely a plate of cells; reproducing asexually (propagation) by fission and gonidia, and sexually (generation) by the union of gametes, which are commonly free-swimming; nucleus with a membrane; chromatophores differentiated, and containing chlorophyll. Typically freshwater plants.

Class 3. PROTOCOCCOIDEAE. Plants all unicellular, sometimes aggregated into colonies.

Order PALMELLALES. Cells not in true colonies.

Family 1. **Pleurococcaceae**. No zoospores; chlorophyll present. *Pleurococcus*, *Ankistrodesmus*. (Pf. I, 2, 54.)

Family 2. **Protococcaceae**. With zoospores; chlorophyll present. *Protococcus*, *Tetraspora*, *Chlorochytrium*. (Pf. I, 2, 43, 60.)

Family 3. **Synchytriaceae**. With zoospores; no chlorophyll; colorless parasitic hysterothytes. *Olpidium*, *Synchytrium*. (Pf. I, 1, 71.)

Order COENOBIALES. Cells in true colonies.

Family 4. **Hydrodictyaceae**. With zoospores; chlorophyll present; cells aggregated into floating colonies. *Pediastrum*, *Scenedesmus*, *Hydrodictyon*. (Pf. I, 2, 70.)

Family 5. **Volvocaceae**. Vegetative cells ciliated; zoospores present; chlorophyll present; cells single or aggregated into motile colonies. *Gonium*, *Pandorina*, *Volvox*. (Pf. I, 2, 29.) On

the extreme frontier of the Vegetable Kingdom, and probably to be relegated to the Animal Kingdom.

Class 4. CONFERVOIDEAE. Plants filamentous, simple or branched, or a sheet of cells.

Order MICROSPORALES. Filaments unbranched; chromatophore one, large, parietal, reticulated, or band-like, without pyrenoids; propagation by hypnospores or biciliated or quadriciliated zoospores; generation unknown.

Family 6. **Microsporaceae**. With the characters of the order. Freshwater algae. *Microspora*. (Pf. I, 2, 84.)

Order SCHIZOGONIALES. Filaments unbranched, often fused laterally into broad parenchymatous sheets; chromatophore one, central, stellate, containing one pyrenoid; propagation by non-ciliated spores (akinetes and tetraspores); generation unknown.

Family 7. **Prasiolaceae**. With the characters of the order. Freshwater and marine algae. *Prasiola*. (Pf. I, 2, 79.)

Order ULVALES. Plant a sheet or tube of one or two layers of cells, attached below; chromatophore one, parietal, containing one pyrenoid; propagation by biciliated or quadriciliated zoospores; generation by biciliated isogametes.

Family 8. **Ulvaceae**. With the characters of the order. Mostly marine plants; a few in fresh waters. *Ulva*, *Enteromorpha*. (Pf. I, 2, 74.)

Order CHAETOPHORALES. Filaments usually branched; chromatophore parietal, usually one, and usually with one or more pyrenoids; propagation by biciliated or quadriciliated zoospores, or by akinetes; generation by isogametes or heterogametes.

Family 9. **Ulotrichaceae**. Filaments unbranched; chromatophore a single parietal plate, containing one to many pyrenoids; propagation by biciliated or quadriciliated zoospores; generation isogamic, the gametes biciliated. *Ulothrix*, *Uronema*. (Pf. I, 2, 79.)

Family 10. **Chaetophoraceae**. Filaments with attenuated multicellular branches, which terminate in multicellular hairs; chromatophore a single parietal plate, containing one or more pyrenoids; propagation by biciliated or quadriciliated zoospores;

generation isogamic, the gametes biciliated. *Draparnaldia*, *Chaetophora*. (Pf. I, 2, 86.)

Family 11. **Microthamniaceae**. Filaments with scarcely attenuated multicellular branches without hairs; chromatophore a single parietal plate containing one or more pyrenoids; propagation by biciliated or quadriciliated zoospores; generation isogamic, the gametes biciliated. *Microthamnion*. (Pf. I, 2, 97.)

Family 12. **Trentopohliaceae**. Filaments with scarcely attenuated multicellular branches, without hairs; chromatophores several, parietal, disc-like, without pyrenoids; propagation by biciliated zoospores; generation isogamic, the gametes biciliated; both zoospores and gametes are produced in special lateral cells. *Trentopohlia*. (Pf. I, 2, 99.)

Family 13. **Herposteiraceae**. Filaments with scarcely attenuated multicellular branches, bearing lateral unicellular hairs; chromatophore a single parietal plate containing a pyrenoid; propagation by quadriciliated zoospores; generation heterogamic, the gametes quadriciliated and free swimming. *Herposteiron*. (Pf. I, 2, 94.)

Family 14. **Cylindrocapsaceae**. Filaments unbranched; chromatophore a single parietal plate with a pyrenoid; propagation by biciliated zoospores; generation heterogamic, the sperms biciliated, the egg non-ciliated remaining in the oogone. *Cylindrocapsa*. (Pf. I, 2, 106.)

Family 15. **Oedogoniaceae**. Filaments simple or branched, sometimes bristle-bearing, chromatophore a single parietal plate with one or more pyrenoids; propagation by multiciliated zoospores; generation heterogamic, the sperms multiciliated, the egg non-ciliated and remaining in the oogone. *Oedogonium*, *Bulbochacta*. (Pf. I, 2, 108.)

Family 16. **Monoblepharidaceae**. Filaments simple or branched, septate above, tubular below, colorless; propagation by unciliated zoospores; generation heterogamic, the sperms unciliated, the eggs non-ciliated, and remaining in the oogone. Small, saprophytic aquatic fungi. *Monoblepharis*. (Pf. I, 1, 106.)

Order COLEOCHAETALES. Filaments branched, usually fusing laterally into rounded or irregular discs; chromatophore one,

large, parietal, with one pyrenoid; propagation by biciliated zoospores; generation by heterogametes, and the production of a fruit.

Family 17. **Coleochaetaceae**, with the characters of the order. Minute freshwater plants. *Coleochaete*. (Pf. I, 2, 111.)

Phylum III. **ZYGOPHYCEAE**. The Conjugate Algae.

Plants microscopic, consisting typically of simple unbranched rows of cells, often separating early into isolated cells; green, with lamelliform, taeniform (ribbon-like), or granular chromatophores (in one class yellowish by the addition of phycoxanthin); propagation by cell-fission; generation by the union of the protoplasm of pairs of cells ("conjugation," or aplanatic isogamy).

Class 5. CONJUGATAE. Chlorophyll-green plants with un-silicified cell walls. Typically freshwater plants.

Order ZYGNEMALES. Plants filamentous, unbranched and cylindrical. Pond scums, floating in quiet fresh waters.

Family 1. **Spirogyraceae**. Chromatophores one to nine, taeniform, parietal, spiral. *Spirogyra*, *Sirogonium*. (Pf. I, 2, 16.)

Family 2. **Zygnemataceae**. Chromatophores two, rounded or stellate, axial. *Zygnema*, *Zygogonium*. (Pf. I, 2, 16.)

Family 3. **Mesocarpaceae**. Chromatophore a single long axial plate. *Mougeotia*, *Gonatonema*. (Pf. I, 2, 21.)

Order DESMIDIALES. Plants typically filamentous, but usually separating early into single cells, mostly flattened. Desmids, mostly in fresh water.

Family 4. **Desmidiaceae**. Cells in unbranched filaments. *Genticularia*, *Hyalotheca*, *Desmidium*. (Pf. I, 2, 1.)

Family 5. **Closteriaceae**. Cells solitary, elongated, not at all or but moderately constricted. *Penium*, *Closterium*. (Pf. I, 2, 1.)

Family 6. **Cosmariaceae**. Cells solitary, broad, deeply constricted. *Cosmarium*, *Micrasterias*. (Pf. I, 2, 1.)

Class 6. BACILLARIOIDEAE. Brownish-green plants containing phycoxanthin in addition to chlorophyll; walls usually silicified. Typically marine plants.

Order EUPODISCALES. Cells in transection cylindrical, less commonly polygonal, elliptical, or irregular; typically in filaments, but more commonly isolated by fragmentation; ends of cells marked concentrically or radially by dots, areolations, lines, or ribs; cells often with spines, processes, or horns. "Round Diatoms," mostly marine.

Family 7. **Coscinodiscaceae**. Cells short, often in filaments, transection circular, not divided into sectors by ribs. *Lysigonium*, *Coscinodiscus*. (Pf. I, 1b, 58.)

Family 8. **Actinodiscaceae**. Cells short, transection circular, divided into sectors by ribs, without "eyes." *Arachnoidiscus*, *Actinodiscus*, *Asterolampra*. (Pf. I, 1b, 68.)

Family 9. **Eupodiscaceae**. Cells short, transection circular, with radial undulations, with "eyes." *Actinocyclus*, *Eupodiscus*. (Pf. I, 1b, 76.)

Family 10. **Soleniaceae**. Cells long, often in filaments, transection circular. *Rhizosolenia*. (Pf. I, 1b, 82.)

Family 11. **Chaetoceraceae**. Cells short, usually in filaments, transection circular to elliptical, with horns longer than the cells. *Chaetoceras*. (Pf. I, 1b, 85.)

Family 12. **Biddulphiaceae**. Cells short, often in filaments, or loose chains, transection circular, polygonal, or commonly elliptical, with horns shorter than the cells. *Triceratium*, *Isthmia*, *Biddulphia*. (Pf. I, 1b, 87.)

Family 13. **Euodiaceae**. Cells short, transection lunate without transverse septa. *Hemidiscus*. (Pf. I, 1b, 99.)

Family 14. **Anauliaceae**. Cells short, transection not lunate, with transverse septa, without spines. *Anaulus*, *Terpsinoc*. (Pf. I, 1b, 97.)

Family 15. **Rutilariaceae**. Cells short, transection not lunate, without transverse septa, with a marginal row of spines. *Rutilaria*. (Pf. I, 1b, 100.)

Order NAVICULALES. Cells in transection narrowly elliptical to linear, less commonly broadly elliptical, lunate, cuneate, or irregular, typically in filaments, but more commonly isolated by fragmentation; ends of cells marked pinnately or transversely by dots,

areolations, lines, or ribs; cells usually without spines, processes, or hairs. "Long Diatoms," mostly in fresh waters.

Family 16. **Tabellariaceae**. Rachis a narrow unmarked strip, no slit; cells usually little shorter than broad, or longer; mostly in filaments. *Grammatophora*, *Rhabdonema*. (Pf. I, 1b, 101.)

Family 17. **Meridionaceae**. Rachis a narrow unmarked strip, no slit; cells generally much shorter than broad; often in filaments, cuneate in girdle view. *Meridion*. (Pf. I, 1b, 107.)

Family 18. **Fragilariaceae**. Rachis a narrow unmarked strip, no slit; cells generally much shorter than broad; often in filaments, generally rectangular in girdle view. *Fragilaria*, *Synedra*. (Pf. I, 1b, 110.)

Family 19. **Naviculaceae**. Rachis containing a median, elongated slit. *Navicula*, *Amphipectura*, *Cymbella*. (Pf. I, 1b, 122.)

Family 20. **Bacillariaceae**. Rachis containing a lateral elongated slit (not plainly visible), *Bacillaria*. (Pf. I, 1b, 142.)

Family 21. **Surirellaceae**. Rachis a narrow unmarked strip; valve with two lateral wing-keels each enclosing a slit. *Surirella*, *Campylodiscus*. (Pf. I, 1b, 145.)

Phylum IV. **SIPHONOPHYCEAE**. The Tube Algae.

Plants coenocytic, filamentous, or saccate, often much branched, and usually basally attached by rhizoids, from septate (consisting of rows of coenocytes) to non-septate, the filaments single or aggregated into a plant body of definite form; chromatophores discoid or reticulated, parietal; propagation by (1) the internal division of the protoplasm of a part (sporangium), or of the whole plant into spores,—in water into zoospores,—in the air into walled spores; or by (2) the contraction of definite masses of protoplasm into agamic resting-spores (aplanospores or chlamyospores); generation by the union of (1) ciliated isogametes, (2) ciliated heterogametes, or (3) spermatozoids with non-ciliated gynogametes (eggs), or of (4) antherid nuclei (non-ciliated) with eggs, in all cases producing zygotes. Typically freshwater and marine algae (holophytes), from which many filamentous fungi (heterophytes) have been derived.

Class 7. VAUCHERIOIDEAE. Plants filamentous, septate or tubular.

Order CLADOPHORALES. Filaments septate, the segments coenocytic.

Family 1. **Cladophoraceae**. Filaments simple or branched, basally attached; isogamic. *Rhizoclonium*, *Cladophora*, *Pithophora*. (Pf. I, 2, 114.)

Family 2. **Sphaeropleaceae**. Filaments simple, unattached, heterogamic. *Sphaeroplea*. (Pf. I, 2, 121.)

Order SIPHONALES. Filaments tubular, irregularly branched; chlorophyllose holophytes.

Family 3. **Phyllosiphonaceae**. Endophytic and parasitic in the tissues of higher plants. *Phyllosiphon*. (Pf. I, 2, 125.)

Family 4. **Codiaceae**. Filaments compacted into a large plant body; isogamic; marine. *Codium*, *Penicillus*, *Udotea*, *Halimeda*. (Pf. I, 2, 138.)

Family 5. **Vaucheriaceae**. Filaments single, free; heterogamic; in fresh or brackish waters, or on wet earth. *Vaucheria*. (Pf. I, 2, 131.)

Order SIPHONOMYCETAE. Filaments tubular, irregularly branched; chlorophyll-less hysterochytes.

Family 6. **Saprolegniaceae**. Aquatic, well-developed, free, parasitic or saprophytic filaments, attached by endogenous rhizoids. *Saprolegnia*, *Achlya*. (Pf. I, 1, 93.)

Family 7. **Cladochytriaceae**. Aquatic, endogenous, branched parasitic filaments, with no rhizoids. *Cladochytrium*. (Pf. I, 1, 80.)

Family 8. **Ancylistaceae**. Aquatic, endogenous, simple, few celled parasitic filaments with no rhizoids. *Lagenidium*, *Rhizomyxa*. (Pf. I, 1, 89.)

Family 9. **Peronosporaceae**. Parasites in the tissues of higher plants, usually not aquatic. *Albugo*, *Phytophthora*, *Peronospora*. (Pf. I, 1, 108.)

Family 10. **Mucoraceae**. Mostly saprophytic on various substances, or parasitic on other fungi. *Mucor*, *Hydrogera*, *Piptocephalis*. (Pf. I, 1, 119.)

Family 11. **Entomophthoraceae**. Mostly parasites in the bodies of insects, less commonly in plants, or saprophytes. *Entomophthora*. (Pf. I, 1, 134.)

Class 8. BRYOPSIDOIDEAE. Plants globular to stipitate, or dendroid, septate or continuous.

Order VALONIALES. Globular, mostly terrestrial coenocytes, to compound septate marine plants.

Family 12. **Botrydiaceae**. Minute globular or ovoid, mostly terrestrial plants chlorophyll-bearing. *Botrydium*, *Protosiphon*. (Pf. I, 2, 123.)

Family 13. **Chytridiaceae**. Minute globular or ovoid colorless plants, mostly epiphytic. *Rhizidium*, *Chytridium*. (Pf. I, 1, 64.)

Family 14. **Valoniaceae**. Plants filamentous and non-septate when young, basally attached by rhizoids, usually becoming septate and branched, and often compound when mature, the segments coenocytic. *Valonia*, *Struvea*, *Halicystis*. (Pf. I, 2, 145.)

Order DASYCLADALES. Non-septate, regularly branched marine plants.

Family 15. **Derbesiaceae**. Plants filamentous, sparingly dichotomous, erect, with basal rhizoids, zoospores multiciliated. *Derbesia*. (Pf. I, 2, 129.)

Family 16. **Bryopsidaceae**. Plants pinnately branched, erect, with basal rhizoids; gametes biciliated. *Bryopsis*. (Pf. I, 2, 127.)

Family 17. **Caulerpacae**. Plants large, branched, creeping, with lateral rhizoids and bearing erect, usually pinnate "leaves." *Caulerpa*. (Pf. I, 2, 134.)

Family 18. **Dasycladaceae**. Plants erect, regularly branched in whorls, with basal rhizoids. *Acctabularia*. (Pf. I, 2, 152.)

Phylum V. PHAEOPHYCEAE. The Brown Algae.

Plants truly cellular, from filamentous and few-celled to massive organisms differentiated into roots, stems, and leaves; brown-green, the cells containing phycoxanthin in addition to chlorophyll; propagation by zoospores and tetraspores; generation by isogametes and heterogametes. Typically marine plants.

This phylum probably originated in the vicinity of the *Ulotrichaceae* in the Protophyceae. The addition of phycophaein is probably related in some way to the marine habitat of the plants.

Class 9. PHAEOSPOREAE. Reproductive organs external, on the surface, or upon special branches; propagation usually by zoospores produced in unilocular sporangia, and generation by isogametes or heterogametes, produced in multilocular sporangia.

Order ECTOCARPALES (ISOAGONICAE). Reproductive cells (zoospores and isogametes) similar and motile.

Family 1. **Ectocarpaceae**. Plants mostly filamentous, simple or branched; both unilocular and multilocular sporangia present. *Ectocarpus*, *Streblonema*. (Pf. I, 2, 182.)

Family 2. **Myriotrichiaceae**. Plants filamentous, densely clothed with short branches; both unilocular and multilocular sporangia present. *Myriotrichia*. (Pf. I, 2, 214.)

Family 3. **Choristocarpaceae**. Plants filamentous, unbranched; both unilocular and multilocular sporangia present. *Pleurocladia*, *Choristocarpus*. (Pf. I, 2, 190.)

Family 4. **Sphacelariaceae**. Plants erect, branched, usually massive, rarely a simple row of cells; both unilocular and multilocular sporangia present. *Sphacclaria*, *Halopeltis*, *Stypocaulon*. (Pf. I, 2, 192.)

Family 5. **Ralfsiaceae**. Plants consisting of leathery layers of cells on rocks, etc.; both unilocular and multilocular sporangia are present. *Ralfsia*. (Pf. I, 2, 240.)

Family 6. **Encoeliaceae**. Plants from filamentous to club-shaped, globular, and reticulated; both unilocular and multilocular sporangia are present. *Punctaria*, *Phyllitis*, *Soranthera*. (Pf. I, 2, 197.)

Family 7. **Striariaceae**. Plants parenchymatous, variously branched, growing by a subterminal meristematic region; both unilocular and multilocular sporangia are present. *Phloespora*, *Striaria*. (Pf. I, 2, 204.)

Family 8. **Arthrocladiaceae**. Plants filamentous above, parenchymatous below, with a subterminal meristematic region, copiously branched. The multilocular sporangia arise above the growing region. *Arthrocladia*. (Pf. I, 2, 209.)

Family 9. **Desmarestiaceae.** Plants filamentous above, parenchymatous below, with a subterminal meristematic region, copiously branched. The unilocular sporangia arise below the growing region. *Desmarestia*. (Pf. I, 2, 209.)

Family 10. **Dictyosiphonaceae.** Plants parenchymatous, of two layers of cells, branched, growing by an apical cell, and attached below by a dense mass of rhizoids. Only unilocular sporangia are known. *Dictyosiphon*. (Pf. I, 2, 212.)

Family 11. **Elachistaceae.** Plants minute, filamentous or pulvinate, mostly epiphytic; both unilocular and multilocular sporangia are present. *Elachista*, *Halothrix*. (Pf. I, 2, 216.)

Family 12. **Chordariaceae.** Plants mostly minute, pulvinate or filamentous, slimy, growing region subterminal; both unilocular and multilocular sporangia are present. *Myrionema*, *Chordaria*. (Pf. I, 2, 221.)

Family 13. **Stilophoraceae.** Plants filiform, consisting of a central row of cells surrounded by a mantle of parenchymatous cells; both unilocular and multilocular sporangia are present. *Stilophora*. (Pf. I, 2, 230.)

Family 14. **Spermatochneaceae.** Plants filiform, consisting of a central strand of cells surrounded by a mantle of parenchymatous cells. Only unilocular sporangia are known. *Spermatochneus*. (Pf. I, 2, 233.)

Family 15. **Sporochneaceae.** Plants medium sized, branched, composed of united filaments, the branches terminating in tufts of hairs, at whose bases are the growing regions. *Sporochneus*. (Pf. I, 2, 236.)

Family 16. **Laminariaceae.** Plants large, massive, usually consisting of a stalk, rooted below and bearing one or more leaves above; unilocular sporangia only are known; these are borne superficially in sori on the leaves. *Chorda*, *Alaria*, *Laminaria*, *Costaria*, *Lessonia*, *Postelsia*, *Nercecystis*, *Macrocystis*. (Pf. I, 2, 242.)

Order CUTLERIALES (GYNOCRATAE). Reproductive cells unlike; zoospores medium sized, sperms small, eggs large, all biciliated and motile.

Family 17. **Cutleriaceae**. Plants medium to large, flat, branched or orbicular, attached by rhizoids. *Cutleria*, *Zanardinia*. (Pf. I, 2, 262.)

Order TILOPTERIDALES (ACINETAE). Reproductive cells unlike; zoospores medium sized, biciliated; sperms small, biciliated; eggs large, non-ciliated.

Family 18. **Tilopteridaceae**. Plants consisting of tufted, more or less branched, filaments attached below by rhizoids. *Tilopteris*. (Pf. I, 2, 265.)

Class 10. TETRASPOREAE. Reproductive organs external on the surface, or on special plants; propagation by tetraspores (non-ciliated); generation by non-ciliated heterogametes.

Order DICTYOTALES. Plants erect, flat, leaf-like, often zoned, attached below by rhizoids.

Family 19. **Dictyotaceae**. With the characters of the order. *Zonaria*, *Padina*, *Dictyota*. (Pf. I, 2, 291.)

Class 11. CYCLOSPOREAE. Reproductive organs sunken in "conceptacles"; propagation by simple fragmentation, no zoospores; sperms small, biciliated; eggs large, non-ciliated.

Order FUCALES. Plants from medium to large, usually flattish, branched, attached below by rhizoids.

Family 20. **Durvillaeaceae**. Conceptacles on the vegetative portions of the plant, no differentiation of reproductive and vegetative branches. *Durvillaea*, *Splachnidium*. (Pf. I, 2, 268, 278, 279, 289.)

Family 21. **Himanthaliaceae**. Conceptacles on long, dichotomous fertile branches which spring from a cup-shaped vegetative base; oogones one-spored. *Himantalia*. (Pf. I, 2, 268, 278, 279.)

Family 22. **Fucaceae**. Conceptacles on the specialized ends of the vegetative branches, sometimes on the whole plant; oogones with two to eight spores. *Myriodesma*, *Fucus*, *Ascophyllum*. (Pf. I, 2, 268.)

Family 23. **Sargassaceae**. Conceptacles on small lateral branches; oogones one-spored. *Sargassum*, *Halidrys*, *Cystoscira*. (Pf. I, 2, 268, 279, 281.)

Phylum VI. **CARPOPHYCEAE.** The Higher Algae.

Plants aquatic, from filamentous to erect, well differentiated stems, which are rooted below and sometimes bear flat, leaf-like structures; propagation by non-motile tetraspores, or by simple fragmentation of the plant body; generation by heterogametes, the fertilized egg developing into one or more (often many) spores, which are enclosed in a sterile tissue, the whole constituting a primitive fruit. In addition to chlorophyll most plants of this phylum, nearly all of which are marine, contain phycoerythrin in their cells. This is not the case, however, with the plants of the class Charoideae, which are mostly inhabitants of fresh waters, and are of a bright green color.

Class 12. **BANGIOIDEAE.** Antherids and oogones developed from ordinary cells of the plant body by a slight enlargement, the former producing non-ciliated sperms, and the latter scarcely differentiated single eggs; no trichogyne. Red or purple plants.

Order **BANGIALES.** Plants filamentous or stratose; propagation by monospores (undivided tetraspores); chromatophore one in each cell, stellate.

Family 1. **Bangiaceae.** Composed of a few genera, and from forty to fifty species, including the edible "laver" (species of *Porphyra*). (Pf. I, 2, 307.)

Order **RHODOCHAETALES.** Plants filamentous, erect, branched; propagation by monospores; chromatophores several to many in each cell.

Family 2. **Rhodochaetaceae.** Filaments not corticated. But one genus, *Rhodochaete*, containing a single marine species. (Pf. I, 2, 316.)

Family 3. **Campsopogonaceae.** Filaments corticated. But one genus, *Campsopogon*, containing a few freshwater species. (Pf. I, 2, 318.)

Class 13. **FLORIDEAE.** Antherids composed of definite groups of cells, superficial or on branches, producing non-ciliated sperms; oogone a single cell prolonged above into a long fine hair, the trichogyne, and containing a definite egg in its base. Red or purple plants.

Order NEMALIONALES. The fertilized oogone gives rise directly to the erect or more or less spreading, tufted sporophores ("gonimoblasts"), which are naked, or enclosed in a protective envelope.

Family 4. **Lemaneaceae.** Plants consisting of delicate branching threads, living in freshwater. *Lemanea*. (Pf. I, 2, 324.)

Family 5. **Helminthocladiaceae.** Plants filamentous, simple or parenchymatous, variously branched, usually slimy and sometimes encrusted with lime; mostly marine. *Batrachospermum* (in fresh water), *Nemalion*, *Liagora*. (Pf. I, 2, 327.)

Family 6. **Thoreaceae.** Plants erect, filamentous, simple or branched, covered with parallel hairs, living in fresh water. *Thorea* is the only genus. (Pf. I, 2, 321.)

Family 7. **Chaetangiaceae.** Plants varying from dichotomously branching, rounded stems to more or less flattened, massive, leaf-like structures; all marine. *Chaetangium*. (Pf. I, 2, 325.)

Family 8. **Gelidiaceae.** Plants ranging from minute epiphytes to slender and gracefully branched forms, and stout branched parenchymatous masses, all marine, and a few species (of *Choreocolax*) parasitic and colorless. *Wrangelia*, *Gelidium*. (Pf. I, 2, 340.)

Order GIGARTINALES. The fertilized oogone conjugates with its nearby auxiliary cell; the latter then gives rise to the sporophores, which branch copiously in the surrounding tissue of the plant body.

Family 9. **Acrotylaceae.** Plants parenchymatous, erect, branching, flattish; tetraspores zonate. *Acrotylus*. (Pf. I, 2, 350.)

Family 10. **Gigartinaceae.** Plants parenchymatous, erect or spreading, branching, cylindrical, flattened, or leaf-like; tetraspores cruciate. *Chondrus*, *Iridaca*, *Gigartina*, *Callophyllis*, *Calymenia*. (Pf. I, 2, 352.)

Family 11. **Rhodophyllidaceae.** Plants parenchymatous, erect or spreading, branching, flattened, or less commonly leaf-like; tetraspores zonate. *Rhodophyllis*, *Rhabdonia*. (Pf. I, 2, 366.)

Order RHODYMENIALES. The fertilized oogone conjugates with

its nearby auxiliary cell; the latter then gives rise to the sporophores which grow outward in the plant body.

Family 12. **Sphaerococcaceae**. Plants not foliaceous, much branched, often robust and of dense texture. *Gracilaria*, *Hypnea*. (Pf. I, 2, 382.)

Family 13. **Rhodymeniaceae**. Plants from filiform to cylindrical-branched, flattened, and foliaceous. *Rhodymenia*, *Champia*, *Plocamium*. (Pf. I, 2, 396.)

Family 14. **Delessariaceae**. Plants foliaceous, often with midribs, and regular netted patterns. Here are some of the most beautiful of the red seaweeds. *Nitophyllum*, *Crinellia*, *Delessaria*. (Pf. I, 2, 406.)

Family 15. **Bonnemaisoniaceae**. Plants consisting of long, slender main stems covered with filamentous branches. *Bonnemaisonia*. (Pf. I, 2, 417.)

Family 16. **Rhodomelaceae**. Plants cylindrical or flattened, mostly much branched, often foliaceous; structure mostly parenchymatous and polysiphonous. *Polysiphonia*, *Rhodomela*, *Dasya*. (Pf. I, 2, 421.)

Family 17. **Ceramiales**. Plants filiform, sometimes corticated, mostly laterally branched, complanate. *Lejolisia*, *Callithamnion*, *Ptilota*, *Ceramium*. (Pf. I, 2, 481.)

Order CRYPTONEMIALES. Oogones and auxiliary cells separated; the fertilized egg conjugates with the remote auxiliary celi by means of its long branching filament ("ooblastema"); the auxiliary cell then gives rise to the sporophores.

Family 18. **Gloiosiphoniaceae**. Plants terete or complanate, forked or laterally branched, more or less filamentous internally. *Gloiosiphonia*, *Gloiopeltis*. (Pf. I, 2, 505.)

Family 19. **Grateloupiaceae**. Plants terete or angled, complanate or foliaceous, variously forked, or more commonly laterally branched, more or less filamentous internally. *Halymenia*, *Grateloupia*, *Cryptonemia*. (Pf. I, 2, 508.)

Family 20. **Dumontiaceae**. Plants terete, complanate, or foliaceous, forked or laterally branched, more or less tubular internally. *Dumontia*, *Dudresnaya*. (Pf. I, 2, 515.)

Family 21. **Nemastomaceae**. Plants terete, complanate, or fo-

liaceous, variously forked or laterally branched, more or less filamentous internally. *Schizymeria*, *Nemastoma*. (Pf. I, 2, 521.)

Family 22. **Rhizophyllidaceae**. Plants terete or compressed, sometimes articulate-constricted, sometimes creeping; structure mostly filamentous. *Chondrococcus*, *Rhizophyllis*. (Pf. I, 2, 527.)

Family 23. **Squamariaceae**. Plants usually minute, foliaceous, or crustiform, attached by rhizoids on their lower surface, usually encrusted with lime. *Peyssonellia*. (Pf. I, 2, 532.)

Family 24. **Corallinaceae**. Plants from filamentous, more or less branched (and then jointed) to foliaceous or crustaceous, always encrusted with lime. *Corallina*, *Mclobesia*. (Pf. I, 2, 537.)

Class 14. CHAROIDEAE. Antheridial branches compounded into a globular structure containing many sperm-bearing filaments, the true antherids; sperms biciliated; oogone rounded, covered with a twisted layer of protective cells; no trichogyne. Green plants.

Order CHARALES. Plants consisting of erect, branching stems, bearing whorled branches. Stems and branches composed of large, long cells which are often covered (corticated) with smaller cells.

Family 25. **Nitellaceae**. Crown of oogone composed of ten cells. *Nitella*, *TolyPELLA*. (Pf. I, 2, 172.)

Family 26. **Characeae**. Crown of oogone composed of five cells. *Chara*, *Tolyptopsis*, *Lamprothamnus*, *Lychnothamnus*. (Pf. I, 2, 174.)

Phylum VII. **CARPOMYCETEAE**. The Higher Fungi.

Plants terrestrial or aerial, filamentous, sometimes compacted into a definite plant body, always destitute of chlorophyll, and so parasitic or saprophytic; propagation by the separation of special cells (conidia), and the production of thick walled cells (chlamydospores) in the plant body; generation (where known) by the union of the protoplasm of an antherid with the protoplasm (egg) of an oogone, and the production of a fruit-body (spore-fruit, or sporocarp) consisting of sporogenous and sterile tissues.

Terrestrial or epiphytic plants for the most part, a few being aquatic, or epizoid.

Class 15. ASCOSPORA. Spore-fruits spherical, cup-shaped, or irregular, simple or compound, always including one or more spore-sacs (asci) containing spores (ascospores).

Order LABOULBENIALES. Plants minute, few-celled, erect, attached below, and bearing one or more antherids and oogones, which produce one or more simple, ascigerous fruits.

Family 1. **Laboulbeniaceae**. Plants parasitic upon insects (mostly upon beetles) or at least attached to them. Twenty-eight genera, and more than one hundred and fifty species are known. *Laboulbenia*, *Ceratomyces*. (Pf. I, 1, 491.)

Order PERISPORIALES. Plants filamentous, producing minute, simple, mostly spherical spore fruits, consisting of one to many asci enclosed in a hard, cellular shell (perithecium).

Family 2. **Erysiphaceae**. Superficial parasites upon higher plants, the filaments white with abundant, simple, vertical conidophores, the blackish, spherical spore fruits with radiating, usually forked appendages. *Erysiphe*, *Microsphaera*. (Pf. I, 1, 328.)

Family 3. **Perisporiaceae**. Mostly saprophytes with the yellow or black fruits usually without appendages. *Parodiella*, *Perisporium*. (Pf. I, 1, 333.)

Family 4. **Microthyriaceae**. Minute superficial parasites upon higher plants, the filaments dark colored; spore fruits flattish, unappendaged, containing 8-spored asci. *Microthyrium*, *Asterina*. (Pf. I, 1, 338.)

Order PYRENOZYCEALES. Plants filamentous (in many "lichens" compacted into a thallus), producing spheroidal, simple or mostly compound spore-fruits, consisting of a hard cellular mass (stroma) in whose surface the perithecia are partially embedded.

Family 5. **Hypocreaceae**. Simple or compound; perithecia mostly reddish or yellowish, subcarose or waxy-membranaceous. *Nectria*, *Epichloe*, *Cordyceps*, *Claviceps*. (Pf. I, 1, 342.)

Family 6. **Dothideaceae**. Compound; perithecia black, coriaceous or carbonaceous, confluent with the stroma. *Ploewrightia*, *Dothidea*, *Phyllachora*. (Pf. I, 1, 373.)

Family 7. **Sordariaceae.** Simple; perithecia soft, brown or black, with or without a stroma; mostly coprophilous. *Sordaria*, *Sporormia*. (Pf. I, 1, 390.)

Family 8. **Chaetomiaceae.** Simple; perithecia superficial, free, brown, and fragile, generally bristly, on a superficial mycelium. *Chaetomium*. (Pf. I, 1, 387.)

Family 9. **Sphaeriaceae.** Simple, perithecia superficial, free, or more or less sunken in the stroma, globular or flattish. *Trichosphaeria*, *Lasiosphaeria*, *Chaetosphaeria*. (Pf. I, 1, 394.)

Family 10. **Ceratostomataceae.** Simple; the perithecia more or less prolonged into a tubular ostiole. *Ceratostomella*, *Ceratostoma*. (Pf. I, 1, 405.)

Family 11. **Cucurbitariaceae.** Perithecia clustered, sometimes united into a compound ascigeious mass, hard, woody or leathery, black or brown. *Nitschkia*, *Cucurbitaria*. (Pf. I, 1, 408.)

Family 12. **Amphisphaeriaceae.** Perithecia, either closely adnate, or somewhat sunken into the matrix; generally hard and carbonaceous, ostiole papilliform. *Amphisphaeria*, *Strickeria*. (Pf. I, 1, 413.)

Family 13. **Lophiostomataceae.** Perithecia scattered, generally more or less buried in the matrix, carbonaceous or subcoriaceous; ostiole an elongated slit. *Lophiostoma*. (Pf. I, 1, 417.)

Family 14. **Mycosphaerellaceae.** Perithecia at first subepidermal, spherical minute. *Guignardia*, *Mycosphaerella*. Pf. I, 1, 421.)

Family 15. **Pleosporaceae.** Perithecia buried in the matrix with only the papiliform ostiole projecting, membranaceous. *Physalospora*, *Venturia*, *Didymella*, *Didymosphaeria*, *Metasphaeria*, *Pleospora*. (Pf. I, 1, 428.)

Family 16. **Massariaceae.** Perithecia for the most part permanently covered by the epidermis with only the papilliform ostiole projecting, coriaceous. *Massaria*. (Pf. I, 1, 444.)

Family 17. **Gnomoniaceae.** Perithecia at first subepidermal, later erumpent, with an elongulated tubular ostiole, membranaceous. *Hendersonia*, *Gnomonia*. (Pf. I, 1, 447.)

Family 18. **Valsaceae.** Perithecia permanently enclosed in a stroma (compound), black. *Anthostoma*, *Valsa*, *Diaporthe*. (Pf. I, 1, 454.)

Family 19. **Melanconidiaceae.** Perithecia buried more or less deeply in the cushion-like stroma; saprophytes. *Melanconis*. (Pf. I, 1, 468.)

Family 20. **Diatrypaceae.** Perithecia immersed in the stroma in one or more series, elongated into neck-like projections; saprophytes. *Calosphaeria*, *Diatrype*. (Pf. I, 1, 472.)

Family 21. **Melogrammataceae.** Perithecia immersed in the stroma (hemispherical) forming under the periderm, then breaking through, pointed or elongated into neck-like projections; saprophytes. *Botryosphaeria*, *Melogramma*. (Pf. I, 1, 477.)

Family 22. **Xylariaceae.** Perithecia peripheral in the massive stroma, which is often hemispherical or clavate, black, or brown, woody or carbonaceous. *Hypoxylon*, *Xylaria*. (Pf. I, 1, 480.)

Order PYRENOLICHENES. Lichen-forming fungi allied to the preceding families, with which they may eventually be merged. Perithecia spherical or hemispherical, weak, with an apical pore or fissure.

Family 23. **Moriolaceae.** Crustaceous lichens, with *Cystococcus* gonidia, which are enclosed in capsular colonies. *Moriola*. (Pf. I, 1*, 52.)

Family 24. **Epigloeaceae.** Gelatinous lichens with *Palmella* gonidia; perithecia spherical, erect. *Epigloea*. (Pf. I, 1*, 53.)

Family 25. **Verrucariaceae.** Crustaceous lichens with *Pleurococcus* or *Palmella* gonidia; perithecia erect, single. *Verrucaria*, *Thelidium*. (Pf. I, 1*, 53.)

Family 26. **Dermatocarpaceae.** Foliaceous or somewhat crustaceous lichens, with *Palmella* gonidia; perithecia erect, single, with minute ostiole. *Dermatocarpon*, *Endocarpon*. (Pf. I, 1*, 58.)

Family 27. **Pyrenothamniaceae.** Fruticose, branching lichens, with *Pleurococcus* gonidia; perithecia erect, single. *Pyrenothamnia*. (Pf. I, 1*, 61.)

Family 28. **Pyrenulaceae.** Crustaceous lichens with *Chroolepus* gonidia; perithecia erect, single, or clustered. *Microthelia*, *Arthropyrenia*, *Porinia*, *Pyrenula*. (Pf. I, 1*, 62.)

Family 29. **Phyllopyreniaceae.** Foliaceous lichens with *Chroolepus* gonidia; perithecia single, sunken. *Lepolichen*. (Pf. I, 1*, 68.)

Family 30. **Trypetheliaceae.** Crustaceous lichens, with *Chroolepus* gonidia; perithecia clustered, erect, sunken. *Trypethelium*. (Pf. I, 1*, 69.)

Family 31. **Paratheliaceae.** Crustaceous lichens, with *Chroolepus* gonidia; perithecia single, with narrow, tubular ostiole. *Parathelium*. (Pf. I, 1*, 71.)

Family 32. **Astrotheliaceae.** Crustaceous lichens, with *Chroolepus* gonidia; perithecia clustered more or less radially. *Astrothelium*, *Parmentaria*. (Pf. I, 1*, 72.)

Family 33. **Strigulaceae.** Crustaceous lichens, with *Cephaleurus* or *Phyllactidium* gonidia; perithecia single, erect. *Phylloporinia*, *Strigula*. (Pf. I, 1*, 74.)

Family 34. **Pyrenidiaceae.** Crustaceous to scaly, and foliaceous lichens with *Nostoc*, *Scytonema*, or *Sirosiphon* gonidia; perithecia single, erect. *Pyrenidium*. (Pf. I, 1*, 76.)

Family 35. **Mycoporaceae.** Crustaceous lichens with *Palmella* or *Chroolepus* gonidia; perithecia flattened, more or less subdivided. *Mycoporum*. (Pf. I, 1*, 77.)

Order PHACIDIALES. True fungi, mostly saprophytic, but sometimes parasitic, with a branching septate mycelium, which bears the mostly open spore fruits (apothecia).

Family 36. **Stictidaceae.** Apothecia fleshy, yellow, not black. *Propolis*, *Stictis*. (Pf. I, 1, 245.)

Family 37. **Tryblidiaceae.** Apothecia leathery or carbonaceous, black, at first sunken in the substratum but later erumpent. *Tryblidium*, *Scleroderris*. (Pf. I, 1, 253.)

Family 38. **Phacidiaceae.** Apothecia leathery or carbonaceous, black, sunken in the substratum. *Phacidium*, *Rhytisma*. (Pf. I, 1, 256.)

Order GRAPHIDALES. Lichen-forming fungi, allied to the preceding, and some of the succeeding families. Apothecia usually elongated, opening by a slit.

Family 39. **Arthoniaceae.** Crustaceous lichens with *Palmella*, *Chroolepus*, or *Phyllactidium* gonidia; apothecia not margined, roundish to oval. *Arthonia*, *Arthothelium*. (Pf. I, 1*, 89.) Compare Family 53. *Celidiaceae*.

Family 40. **Graphidaceae.** Crustaceous lichens with *Palmella* or *Chroolepus* gonidia; apothecia single, margined, oval or roundish. *Opegrapha*, *Graphis*, *Graphina*. (Pf. I, 1*, 92.)

Family 41. **Chiodectonaceae.** Crustaceous lichens with *Chroolepus* or *Phycopeltis* gonidia; apothecia round or elongated, sunken in the stroma. *Sarcographa*, *Chiodecton*. (Pf. I, 1*, 102.)

Family 42. **Dirinaceae.** Crustaceous lichens with *Chroolepus* gonidia; apothecia round or elongated, superficial. *Dirina*. (Pf. I, 1*, 105.)

Family 43. **Roccellaceae.** Fruticose, erect lichens with *Chroolepus* gonidia; apothecia round or elongated, sunken or superficial. *Roccella*. (Pf. I, 1*, 106.)

Order CALICIALES. True fungi, and lichen-forming fungi; apothecia spheroidal, sessile or stalked, the asci and paraphyses breaking up into a pulverulent mass.

Family 44. **Protocaliciaceae.** True fungi; apothecia sessile or stalked; saprophytes *Mycocalicium*. (Syllabus 30.)

Family 45. **Caliciaceae.** Crustaceous lichens with *Protococcus*, *Pleurococcus*, or *Stichococcus* gonidia; apothecia usually long-stalked. *Calicium*. (Pf. I, 1*, 80.)

Family 46. **Cypheliaceae.** Crustaceous lichens with *Pleurococcus*, *Protococcus*, or *Chroolepus* gonidia; apothecia sessile. *Cyphelium*, *Tylophoron*. (Pf. I, 1*, 83.)

Family 47. **Sphaerophoraceae.** Foliose or fruticose lichens, with *Protococcus* gonidia; apothecia sessile or nearly so. *Sphaerophorus*. (Pf. I, 1*, 85.)

Order PEZIZALES. True fungi, saprophytic or parasitic, with a branching filamentous mycelium; apothecia at first usually spherical and closed, later opening, cup-shaped, fleshy, or more or less leathery.

Family 48. **Pyronemataceae.** Apothecia fleshy, open from the first, convex. *Pyronema*. (Pf. I, 1, 178.)

Family 49. **Pezizaceae.** Apothecia fleshy, at first spherical and closed, later open, concave, sessile, or stalked. *Lachnea*, *Peziza*. (Pf. I, 1, 178.)

Family 50. **Ascobolaceae.** Apothecia fleshy, at first spherical and closed, later open, concave; asci opening by a lid, when ripe escaping from the apothecium. *Ascobolus*. (Pf. I, 1, 188.)

Family 51. **Helotiaceae.** Apothecia fleshy, mostly open from the first, usually stalked; asci not opening by a lid. *Sarcoscypha*, *Sclerotinia*, *Dasyscypha*, *Helotium*. (Pf. I, 1, 193.)

Family 52. **Mollisiaceae.** Apothecia fleshy, open from the first, sessile, asci not opening by a lid. *Mollisia*, *Pyrenopeziza*. Pf. I, 1, 210.)

Family 53. **Celidiaceae.** Apothecia leathery, dusky or light colored, roundish, without a peridium. *Lecidiopsis*, *Celidium*. (Pf. I, 1, 218.) Some of the species are very closely related to such lichen-forming fungi as *Arthonia*.

Family 54. **Patellariaceae.** Apothecia leathery or corneous, free from the first, usually dark colored, hemispherical or elongated, cup-shaped or plate-shaped, with a peridium. *Patellaria*, *Biatorella*. (Pf. I, 1, 221.)

Family 55. **Cenangiaceae.** Apothecia leathery or carbonaceous, at first sunken, usually dark colored, at first round and closed, later open, cup-shaped with a peridium. *Cenangium*, *Dermatea*, *Bulgaria*. (Pf. I, 1, 231.)

Family 56. **Cordieritidaceae.** Apothecia on the ends of a branched, carbonaceous, brittle stroma; saprophytes. *Cordicrites*. (Pf. I, 1, 241.)

Family 57. **Cyttariaceae.** Apothecia sunken in the surface of a bulbous, stalked, hard stroma, which eventually is gelatinous; parasites. *Cyttaria*. (Pf. I, 1, 241.)

Order DISCOLICHENES. Lichen-forming fungi, allied to the preceding families, with which they may eventually be merged. Apothecia circular, typically cup-shaped or plate-shaped.

Family 58. **Lecanactidaceae.** Crustaceous lichens with *Chroolepus* gonidia; apothecia sessile or sunken. *Lecanactis*. (Pf. I, 1*, 114.)

Family 59. **Pilocarpaceae.** Crustaceous lichens with *Protococcus* gonidia; apothecia at first sunken, later emergent. *Pilocarpon*. (Pf. I, 1*, 116.)

Family 60. **Chrysothricaceae**. Spongy lichens with *Palmella* gonidia; apothecia sunken disk-form, with a margin. *Chrysothrix*. (Pf. I, 1*, 117.)

Family 61. **Thelotremataceae**. Crustaceous lichens with *Chroolepus* gonidia; apothecia sunken, surrounded by a thalline margin. *Orcellularia*, *Thelotrema*. (Pf. I, 1*, 118.)

Family 62. **Diploschistaceae**. Crustaceous, stratified lichens with *Protococcus* gonidia; apothecia sunken or erumpent, margined. *Diploschistes*. (Pf. I, 1*, 121.)

Family 63. **Ectolechiaceae**. Crustaceous lichens with *Protococcus* gonidia; apothecia sunken to sessile, small, not margined. *Sporopodium*. (Pf. I, 1*, 122.) Growing on leaves.

Family 64. **Gyalectaceae**. Crustaceous lichens with *Chroolepus*, *Phyllactidium*, or rarely *Scytonema* gonidia; apothecia simple, sunken, to sessile, margin weak, bright-colored to carbonaceous. *Gyalecta*. (Pf. I, 1*, 124.)

Family 65. **Coenogoniaceae**. Spongy lichens with *Chroolepus* or *Cladophora* gonidia; apothecia margined, sessile or short-stalked. *Coenogonium*. (Pf. I, 1*, 127.)

Family 66. **Lecidiaceae**. Crustaceous lichens with *Glococapsa*-like, or *Protococcus* gonidia; apothecia sessile, less commonly sunken, or short-stalked. *Lecidia*, *Bacidia*, *Toninia*. (Pf. I, 1*, 129.)

Family 67. **Phylloporaceae**. Scaly to foliose lichens with *Pleurococcus* gonidia; apothecia sessile, with a bright colored or dark margin. *Phyllopsora*. (Pf. I, 1*, 138.)

Family 68. **Cladoniaceae**. Crustaceous to scaly to foliose lichens with *Pleurococcus* gonidia (rarely with *Cyanophyceae* gonidia); apothecia mostly convex, terminal or lateral on vertical stalks (podetia). *Bcomyces*, *Cladonia*, *Stereocaulon*. (Pf. I, 1*, 139.)

Family 69. **Gyrophoraceae**. Foliose, coriaceous lichens attached at a single point, with *Pleurococcus* gonidia; apothecia flat, sessile or stalked, margined. *Gyrophora*, *Umbilicaria*. (Pf. I, 1*, 147.)

Family 70. **Acarosporaceae**. Crustaceous, scaly to foliose lichens with *Pleurococcus* or *Protococcus* gonidia; the thallus

poorly developed in most cases; apothecia in thalline warts in which they are sunken. *Thelocarpon*, *Acarospora*, *Biatorella*. (Pf. I, 1*, 150.)

Family 71. **Ephebaceae**. Dwarf-fruticose or filiform-branched, crustaceous to scaly lichens with *Scytonema* or *Stigonema* gonidia; apothecia small, sunken or superficial. *Spilonema*, *Ephebe*. (Pf. I, 1*, 154.)

Family 72. **Pyrenopsidaceae**. Crustaceous, foliose to fruticose lichens, with *Gloeocapsa*, *Chroococcus*, or *Xanthocapsa* gonidia; apothecia small, closed at first. *Pyrenopsis*, *Synalissa*, *Thyrea*. (Pf. I, 1*, 158.)

Family 73. **Lichinaceae**. Crustaceous to scaly or fruticose-branched lichens, with *Rivularia* gonidia; apothecia spheroidal, closed, sunken, with a bright-colored margin. *Pterygium*, *Lichina*. (Pf. I, 1*, 164.)

Family 74. **Collemataceae**. Gelatinous to crustaceous, scaly, foliose or fruticose lichens, with *Nostoc* gonidia; apothecia closed or open, sunken or sessile, not margined. *Physma*, *Collema*, *Lep-togium*. (Pf. I, 1*, 168.)

Family 75. **Heppiaceae**. Scaly, foliose, irregular or fruticose lichens with *Scytonema* gonidia; apothecia sunken, not margined. *Heppia*. (Pf. I, 1*, 176.)

Family 76. **Pannariaceae**. Crustaceous-corneous, to scaly and foliose lichens (not gelatinous), with *Nostoc* or *Scytonema* gonidia, rarely with *Pleurococcus* gonidia; apothecia superficial or marginal. *Pannaria*, *Psoroma*, *Coccocarpia*. (Pf. I, 1*, 178.)

Family 77. **Stictaceae**. Foliose lichens with *Palmella* or *Nostoc* gonidia; apothecia superficial or marginal, sessile or shield-shaped. *Lobaria*, *Sticta*. (Pf. I, 1*, 185.)

Family 78. **Peltigeraceae**. Foliose lichens with *Palmella* or *Nostoc* gonidia; apothecia flat, large, submarginal, dark colored. *Peltigera*. (Pf. I, 1*, 190.)

Family 79. **Pertusariaceae**. Crustaceous lichens with *Protococcus* gonidia; apothecia mostly punctiform, single or clustered in thalline warts. *Pertusaria*. (Pf. I, 1*, —.)

Family 80. **Lecanoraceae**. Crustaceous lichens with *Protococcus* gonidia; apothecia sunken, not margined. *Lecanora*. (Pf. I, 1*, —.)

Family 81. **Parmeliaceae.** Foliose lichens with *Protococcus* gonidia; apothecia scutellaeform, margined, sunken. *Parmelia*. (Pf. I, 1*, —.)

Family 82. **Usneaceae.** Fruticose lichens, often long and much branched, with *Protococcus* gonidia; apothecia terminal or marginal, scutellaeform, often large. *Usnea*, *Ramalina*. (Pf. I, 1*, —.)

Family 83. **Theloschistaceae.** Foliose to fruticose lichens with *Protococcus* gonidia; apothecia at first sunken, later erumpent, spores colorless. *Theloschistes*. (Pf. I, 1*, —.)

Family 84. **Caloplacaceae.** Crustaceous lichens with *Protococcus* gonidia; apothecia at first sunken, later erumpent, spores colorless. *Caloplaca*. (Pf. I, 1*, —.)

Family 85. **Physciaceae.** Foliose or fruticose lichens with *Protococcus* gonidia; apothecia at first sunken, later erumpent, spores brown. *Physcia*. (Pf. I, 1*, —.)

Family 86. **Buelliaceae.** Crustaceous lichens with *Protococcus* gonidia; apothecia at first sunken, later erumpent, spores brown. *Buellia*. (Pf. I, 1*, —.)

Order HELVELLALES. True fungi, saprophytic, with a branching filamentous mycelium; apothecia open from the first, sessile or more commonly stalked, often convex, fleshy or gelatinous.

Family 87. **Rhizinaceae.** Apothecia fleshy, expanded, sessile *Rhizina*. (Pf. I, 1, 171.)

Family 88. **Geoglossaceae.** Apothecia fleshy, capitate, stalked; asci opening by a slit. *Mitrula*, *Geoglossum*. (Pf. I, 1, 163.)

Family 89. **Helvellaceae.** Apothecia fleshy, capitate, stalked; asci opening by a lid. *Morchella*, *Vcrpa*, *Helvella*. (Pf. I, 1, 167.)

Order HYSTERIALES. True fungi, saprophytic or parasitic, with a branching mycelium, often forming a stroma; apothecia sessile, or at first sunken and later erumpent, usually elongated, dark colored, leathery or carbonaceous, with a narrow slit.

Family 90. **Hypodermataceae.** Apothecia sunken, leathery, round or elongated, black; saprophytes. *Hypoderma*, *Lophiodermium*. (Pf. I, 1, 267.)

Family 91. **Dichaenaceae.** Apothecia at first sunken, later erumpent, leathery, black, elongated, or round; bark-saprophytes. *Diachena*. (Pf. I, 1, 270.)

Family 92. **Ostropaceae.** Apothecia at first deeply sunken, later somewhat erumpent, leathery, black, roundish; saprophytes. *Ostropa*. (Pf. I, 1, 271.)

Family 93. **Hysteriaceae.** Apothecia sessile, narrowly elongated to broad, and even lobed, black, carbonaceous or leathery; saprophytes. *Hysterium*, *Hysterographium*. (Pf. I, 1, 272.)

Family 94. **Acrospermaceae.** Apothecia sessile, erect clavate, corneous, brown, spores very long, filamentous; saprophytes. *Acrospermum*. (Pf. I, 1, 277.)

Order TUBERALES. True fungi, saprophytic, with a branching filamentous, generally subterranean mycelium; spore-fruits tuberous, subterranean, fleshy, containing asci in definite cavities or layers.

Family 95. **Tuberaceae.** Spore-fruits with spore-bearing cavities open to the exterior by rifts or slits in the tissue and rind. *Tuber*. (Pf. I, 1, 281.)

Family 96. **Balsamiaceae.** Spore-fruits with spore-bearing cavities not open to the exterior. *Balsamia*. (Pf. I, 1, 288.)

Order ASPERGILLALES. True fungi, saprophytic, with an abundant branching mycelium which grows superficially, or penetrates the substratum, and eventually bears the small, mostly spherical, fleshy spore-fruits.

Family 97. **Gymnoascaceae.** Spore-fruits usually mere loose masses of hyphae with asci in the center. *Gymnoascus*. (Pf. I, 1, 293.)

Family 98. **Aspergillaceae.** Spore-fruits spheroidal, parenchymatous, with a definite peridium, sessile, not subterranean, opening irregularly. *Aspergillus*, *Penicillium*, *Meliola*. (Pf. I, 1, 297.)

Family 99. **Onygenaceae.** Spore-fruits spheroidal, parenchymatous, with a definite peridium, stalked, not subterranean. *Onygena*. (Pf. I, 1, 309.)

Family 100. **Trichocomataceae.** Spore-fruits cylindrical, erect, with a peridium, sessile, not subterranean. *Trichocoma*. (Pf. I, 1, 310.)

Family 101. **Elaphomycetaceae.** Spore-fruits subterranean, opening irregularly, pulverulent when ripe. *Elaphomyces*. (Pf. I, 1, 311.)

Family 102. **Terfeziaceae.** Spore-fruits subterranean, opening irregularly, not pulverulent when ripe. *Terfezia*. (Pf. I, 1, 312.)

Order EXOASCALES. True fungi, typically parasitic, much reduced and simplified, the branching mycelium bearing single or clustered asci, not forming genuine apothecia.

Family 103. **Exoascaceae.** Parasitic in the tissues of higher plants, producing crowded asci which break through the epidermis. *Exoascus*, *Taphrina*. (Pf. I, 1, 158.)

Family 104. **Ascocorticiaceae.** Saprophytic, the asci forming a cushion on the abundant mycelium. *Ascocorticium*. (Pf. I, 1, 161.)

Family 105. **Endomycetaceae.** Parasitic or saprophytic, the asci single, not clustered in masses or cushions. *Eremascus*, *Endomyces*. (Pf. I, 1, 154.)

Order HEMIASCALES. True fungi mostly saprophytic, much reduced and simplified, the branched mycelium bearing the single few- to many-spored asci.

Family 106. **Ascoideaceae.** Asci much elongated, not corticated. *Ascoidea*. (Pf. I, 1, 145.)

Family 107. **Protomycetaceae.** Asci ellipsoid or spherical, not corticated. *Protomyces* (parasitic), *Endogone*. (Pf. I, 1, 147.)

Family 108. **Monascaceae.** Asci spherical, terminal, corticated. *Monascus*. (Pf. I, 1, 148.)

Family 109. **Saccharomycetaceae.** Asci early isolated from the few-celled mycelium, which itself early breaks up into short segments; saprophytic. *Saccharomyces*. (Pf. I, 1, 153.)

Class 16. TELIOSPOREAE. Parasitic fungi, much reduced and degraded, with a mycelium which penetrates the tissues of the host and produces erumpent spore-clusters (sori) but no definite spore-fruits; conidia single-celled, usually of one or two kinds; asci ("telioasci") reduced, containing one, two, or several ascospores ("teliospores").

Order UREDINALES. Typically producing five kinds of spores, viz., (1) thin-walled sporidia, (2) smooth-walled pycniospores, (3) aeciospores, (4) urediniospores, (5) teliospores.

Family 110. **Aecidiaceae.** Telioasci free or fascicled, usually erumpent; sporidia, pycniospores, aeciospores, urediniospores, and teliospores typically present; walls of spores usually firm. *Uropyxis*, *Phragmidium*, *Accidium*, *Nigredo*, *Uromyces*, *Dicaeoma* ("Puccinia"). (Pf. I, 1**, 48.)

Family 111. **Uredinaceae.** Telioasci compacted into a crust or column, subcuticular or erumpent, walls of spores firm. *Uredo* ("Melampsora"), *Cronartium*. (Pf. I, 1**, 38.)

Family 112. **Coleosporiaceae.** Telioasci compacted laterally into waxy layers; walls of spores weakly gelatinous. *Colcosporium*. (Pf. I, 1**, 42.)

Order USTILAGINALES. Typically producing two kinds of spores, viz., (1) thin-walled sporidia, (2) teliospores, which are here regarded as homologous with the teliospores of the preceding order.

Family 113. **Ustilaginaceae.** Germinating teliospore producing a septated promycelium. *Ustilago*, *Sphacelotheca*. (Pf. I, 1**, 6.)

Family 114. **Tilletiaceae.** Germinating teliospore producing a tubular promycelium. *Tilletia*, *Entyloma*. (Pf. I, 1**, 15.)

Class 17. BASIDIOSPOREAE. True fungi, mostly saprophytes, consisting of septated mycelium which bears the spore-fruits; spores ("basidiospores") borne externally upon special cells ("basidia"), which are usually massed in a hymenium. The basidia are here regarded as the homologues of the asci of the *Ascosporeae*.

Order HYMENOGASTRALES. Spore-fruit fleshy, closed, subterranean wholly, or at first internally filled with irregular cavities which are lined with a hymenium; no capillitium.

Family 115. **Hymenogastraceae.** With the characters of the order. *Secotium*, *Hysterangium*, *Hymenogaster*, *Octaviana*. (Pf. I, 1**, 296.)

Order PHALLALES. Spore-fruit fleshy, when young closed, subterranean at first, internally containing a circular spore-bearing

cavity, later developing a stalk which ruptures the peridium, exposing the spores; no capillitium.

Family 116. **Phallaceae**. Spore-bearing stalk cylindraceous, hollow, capped by the spore mass. *Mutinus*, *Ithyphallus*, *Dictyophora*. (Pf. I, 1**, 289.)

Family 117. **Clathraceae**. Spore-bearing stalk ovoid and reticulated, or cylindrical and branched above; spore mass capitate or between the branches. *Clathrus*, *Simblum*, *Aseroc*. (Pf. I, 1**, 280.)

Order LYCOPERDALES. Spore-fruit fleshy when young, closed, subterranean at first, later superficial, internally filled with irregular spore-bearing canals, or a spore-bearing tissue; capillitium present.

Family 118. **Lycoperdaceae**. Spore-fruit sessile or short-stalked, filled with spore-bearing canals. *Lycoperdon*, *Bovista*, *Gcaster*. (Pf. I, 1**, 315.)

Family 119. **Tylostomataceae**. Spore-fruit long-stalked, when young filled with spore-bearing tissue. *Tylostoma*, *Battarca*. (Pf. I, 1**, 342.)

Order NIDULARIALES. Spore-fruit spherical, top-shaped, or cylindrical, leathery, containing spore-bearing cavities, which by deliquescence of the surrounding tissues become peridioles ("sporangioles").

Family 120. **Nidulariaceae**. Spore-fruits small, sessile upon the ground. *Nidularia*, *Crucibulum*, *Cyathus*. (Pf. I, 1**, 326.)

Order SCLERODEMATALES. Spore-fruit roundish, containing groups of clustered basidia, bearing terminal spores; no capillitium.

Family 121. **Sclerodermataceae**. Spore-fruit often with a stalk-like base. *Podaxon*, *Scleroderma*, *Pisolithus*. (Pf. I, 1**, 329.)

Family 122. **Sphaerobolaceae**. Spore-fruit spherical, the globular spore-mass ejected at maturity. *Sphaerobolus*. (Pf. I, 1**, 346.)

Order HYMENOMYCETALES. Spore-fruit when mature from umbrella-shaped to bracket-shaped, branched, fruticose, foliose, and

vaguely expanded, developing a hymenium on surfaces which are eventually external.

Family 123. **Agaricaceae.** Spore-fruits usually fleshy, typically umbrella-shaped, with hymenium on lamellae on the under side of the cap. *Coprinus*, *Russula*, *Psalliota*, *Agaricus*, *Amanita*. (Pf. I, 1**, 198.)

Family 124. **Polyporaceae.** Spore-fruit fleshy, leathery or woody, from umbrella-shaped to bracket-shaped, and resupinate and expanded; the hymenium lining pits or pores. *Fomes*, *Polyporus*, *Polystictus*, *Boletus*. (Pf. I, 1**, 152.)

Family 125. **Hydnaceae.** Spore-fruit fleshy or leathery, from umbrella-shaped to bracket-shaped, fruticose or resupinate-expanded, the hymenium covering the surface of warts or prickles. *Hydnum*, *Irpe.x.* (Pf. I, 1**, 139.)

Family 126. **Clavariaceae.** Spore-fruits fleshy to leathery, cylindrical to clavate and fruticose, the hymenium covering the outer surface. *Pistillaria*, *Clavaria*. (Pf. I, 1**, 130.)

Family 127. **Thelephoraceae.** Spore-fruits cuticular or leathery, flat, shell-shaped, capitate or branched, the hymenium smooth and covering the surface. *Corticium*, *Stereum*, *Thelephora*. (Pf. I, 1**, 117.)

Family 128. **Hypochnaceae.** Basidia developed upon the flocculent mycelium, forming vague superficial spore-fruits. *Hypochnus*, *Tomentella*. (Pf. I, 1**, 114.)

Order EXOBASIDIALES. Reduced and degraded *Basidiosporae*, related to the preceding families; basidia undivided, more or less rounded.

Family 129. **Exobasidiaceae.** Parasites in the tissues of higher plants, the basidia crowded into a loose hymenium; spores borne on sterigmata. *Exobasidium*. (Pf. I, 1**, 103.)

Family 130. **Tulasnellaceae.** Saprophytes; basidia rounded, without sterigmata. *Tulasnella*. (Syllabus 40.)

Family 131. **Dacryomycetaceae.** Saprophytes; basidia long-clavate, branched in or on gelatinous explanate, cup-shaped fruticose or capitate spore-fruits. *Dacryomyces*, *Guepinia*, *Calocera*. (Pf. I, 1**, 96.)

Order AURICULARIALES. Reduced and degraded *Basidiosporae*, related to the families of the *Hymenomycetales*; basidia divided by transverse partitions.

Family 132. **Auriculariaceae.** Hymenium exposed; spore-fruits from irregular foliose to loose and vague aggregations of basidia; more or less gelatinous. *Platyglora*, *Auricularia*. (Pf. I, 1**, 83.)

Family 133. **Pilacraceae.** Spore-fruits capitate, stalked, closed, filled with basidia. *Pilacre*, *Pilacrella*. (Pf. I, 1**, 86.)

Order TREMELLALES. Reduced and degraded *Basidiosporae* related to the families of the *Hymenomycetales*; basidia divided by vertical partitions.

Family 134. **Sirobasidiaceae.** Spore-fruits gelatinous, open, the basidia in serial rows, spores sessile. *Sirobasidium*. (Pf. I, 1**, 89.)

Family 135. **Tremellaceae.** Spore-fruits gelatinous, open, expanded to foliose and cup-shaped; basidia collateral, elongated. *Exidia*, *Tremella*. (Pf. I, 1**, 90.)

Family 136. **Hyaloriaceae.** Spore-fruits capitate, stalked, closed, the basidia developed in a circular subterminal zone. *Hyaloria*. (Pf. I, 1**, 95.)

FUNGI IMPERFECTI. Here are collected from 10,000 to 12,000 species of fungi with regard to which our knowledge is quite imperfect. We do not know their ascigerous states, if indeed they have any, but it is generally assumed that they are the conidial states of *Ascosporae*, and that possibly in some cases they have lost all else through excessive degeneration. For the present they must be grouped here, and treated as though they were autonomous. They are mostly parasitic.

Order SPHAEROPSIDALES. Conidia developed in pycnidia, i. e. perithecium-like "fruits."

Family 137. **Sphaerioidaceae.** Pycnidia more or less spherical, cuticular, leathery or carbonaceous, black. *Phyllosticta*, *Phoma*, *Sphaeropsis*, *Ascochyta*, *Darlucra*, *Diplodia*, *Scptoria*. (Pf. I, 1**, 349.)

Family 138. **Nectrioidaceae.** Pycnidia more or less spherical, fleshy or waxy, bright colored; spores hyaline. *Zythia*, *Sphaeronomella*, *Aschersonia* (Pf. I, 1**, 382.)

Family 139. **Leptostromataceae.** Pycnidia shield-shaped, cuticular or carbonaceous, black. *Leptothyrium*, *Leptostroma*, *Leptostromella*. (Pf. I, 1**, 386.)

Family 140. **Excipulaceae.** Pycnidia more or less dish-shaped, round or elongated; cuticular or carbonaceous, black. *Excipula*, *Amerosporium*, *Discella*. (Pf. I, 1**, 392.)

Order MELANCONIALES. Conidia developed upon a stroma which eventually breaks through the epidermis.

Family 141. **Melanconiaceae.** Stroma sometimes feebly developed but more often firm and black. *Glocosporium*, *Collectotrichum*, *Melanconium*, *Coryncum*, *Pestalozzia*, *Cylindrosporium*. (Pf. I, 1**, 398.)

Order HYPHOMYCETALES. Conidia developed upon separate conidiophores which do not form a stroma, but penetrate the epidermis or the stomata singly or in clusters.

Family 142. **Mucedinaceae.** Conidiophores hyaline, always separate. *Oospora*, *Monilia*, *Oidium*, *Sterigmatocystis*, *Ovularia*, *Sporotrichium*, *Botrytis*, *Verticillium*, *Ramularia*. (Pf. I, 1**, 416.)

Family 143. **Dematiaceae.** Conidiophores dark or black, always separate. *Torula*, *Trichosporium*, *Dematium*, *Fusicladium*, *Cladosporium*, *Helminthosporium*, *Macrosporium*, *Cercospora*. (Pf. I, 1**, 454.)

Family 144. **Stilbaceae.** Conidiophores united into an erect compound, spore-bearing body. *Isaria*, *Graphium*, *Stysanus*. (Pf. I, 1**, 488.)

Family 145. **Tuberculariaceae.** Conidiophores united into a cushion-like spore-bearing body. *Tuberculina*, *Fusarium*, *Epicoccum*. (Pf. I, 1**, 498.)

Phylum VIII. **BRYOPHYTA.** The Mossworts.

Chlorophyll-green plants exhibiting two generations in each life cycle, viz., (1) the sexual (gametophyte), which bears the

antherids and archegones, and (2) the asexual (sporophyte), which bears spores: gametophyte foliose, rooted, longer-lived; sporophyte neither expanded nor rooted (supported by the gametophyte) and shorter-lived. Typically land plants.

Class 18. HEPATICAE. Liverworts. Mostly bilateral, thalloid, creeping plants, usually with splitting spore-fruits, and having elaters.

Order MARCHANTIALES. Spore-fruits indehiscent with or without elaters; plant thallose.

Family 1. **Ricciaceae**. Small, mostly radiate, thallose plants; spore-fruits sessile in the upper surface of the gametophyte; no elaters. *Riccia*, *Ricciocarpus*. (Pf. I, 3, 8.)

Family 2. **Marchantiaceae**. Branching, thallose plants; spore-fruits mostly clustered, and generally in stalked heads, with elaters. *Grimmaldia*, *Conocephalus*, *Lunularia*, *Marchantia*. (Pf. I, 3, 16.)

Order ANTHOCEROTALES. Spore-fruits with a columella, dehiscent, two-valved, with elaters; plant a thallus.

Family 3. **Anthocerotaceae**. Small terrestrial plants with an expanded thallus, and one or more slender spore-fruits. *Notothylas*, *Anthoceros*. (Pf. I, 3, 135.)

Order JUNGERMANNIALES. Spore-fruits stalked, four-valved, with elaters; plants mostly leafy-stemmed.

Family 4. **Metzgeriaceae**. Apical cell of the thallus never producing an archegone; plants mostly thallose. *Metzgeria*, *Pellia*, *Fossombronia*. (Pf. I, 3, 38.)

Family 5. **Jungermanniaceae**. Apical cell of the thallus eventually producing an archegone; plants with stems and leaves. *Lophosia*, *Plagiochila*, *Lophocolca*, *Bazzania*, *Lepidosia*, *Scapania*, *Frullania*. (Pf. I, 3, 61.)

Class 19. MUSCI. Mosses. Leafy stems, mostly erect, with spore-fruits usually opening by a lid, and having no elaters.

Order ANDREAEALES. Small plants with leaves composed of similar cells; spore-fruit on a pseudopodium, dehiscing by four to six longitudinal slits.

Family 6. **Andreaeaceae**. Rock-loving mosses of a single genus, *Andreaea*. (Pf. I, 3, 262.)

Order SPHAGNALES. Large plants with thick leaves composed of two kinds of cells; spore-fruit on a pseudopodium, dehiscing by a circular lid; no peristome.

Family 7. **Sphagnaceae**. Bog-mosses of considerable size, whose spongy leaves retain moisture for a long time, hence used for moist packing. *Sphagnum*. (Pf. I, 3, 244.)

Order BRYALES. Small to large plants with mostly thin leaves of similar cells; spore-fruits mostly long-stalked, generally opening by a circular lid; peristome usually present.

Suborder ACROCARPI. Spore-fruits terminal upon the main axis.

Family 8. **Archidiaceae**. Small mosses, with sessile thin-walled, indehiscent spore-fruits. *Archidium*. (Pf. I, 3, 288.)

Family 9. **Dicranaceae**. Large to very small, mostly turf-forming mosses; spore capsule with operculum; peristome single, with 16 teeth, rarely absent. *Ditrichum*, *Ceratodon*, *Leucoloma*, *Dicranum*. (Pf. I, 3, 289.)

Family 8. **Leucobryaceae**. Medium-sized, spongy mosses with many-ranked, thick leaves; peristome single, of 16 or 8 teeth. *Leucobryum*, *Leucophanes*. (Pf. I, 3, 342.)

Family 9. **Fissidentaceae**. Medium sized mosses with distichous, winged and equitant leaves; peristome single of 16 mostly divided teeth. *Fissidens*. (Pf. I, 3, 351.)

Family 10. **Calymperaceae**. Medium or small tropical mosses, growing on trees; with a single peristome of 16 teeth. *Syrhodon*, *Calymperes*. (Pf. I, 3, 363.)

Family 11. **Pottiaceae**. Small to medium sized, much branched mosses; leaves hyaline at base; capsule erect, narrowly oval, to cylindrical; peristome single of 16, usually deeply divided, teeth (or wanting, and capsule indehiscent). *Astomum*, *Weisia*, *Didymodon*, *Barbula*, *Phascum*, *Pottia*, *Tortula*, *Encalypta*. (Pf. I, 3, 380.)

Family 12. **Grimmiaceae**. Tufted or pulvinate mosses with short, solid leaves, and capsule regular, on a straight or curved pedicel; peristome single of 16 teeth. *Grimmia*, *Rhacomitrium*. (Pf. I, 3, 439.)

Family 13. **Orthotrichaceae.** Tufted, mostly erect mosses, with solid leaves; capsule erect; peristome simple or double (rarely absent), each whorl of 8 or 16 teeth. *Zygodon*, *Orthotrichum*, *Ulota*, *Macomitrium*. (Pf. I, 3, 456.)

Family 14. **Oedipodiaceae.** Small fleshy mosses; capsule with a long hypophysis and without a peristome. *Oedipodium*. (Pf. I, 3, 508.)

Family 15. **Splachnaceae.** Mosses of soft, loose texture; capsule stalked, generally with an enlarged hypophysis, which is sometimes large and umbrella-shaped. *Splachnum*. (Pf. I, 3, 498.)

Family 16. **Disceliaceae.** Small earth-mosses with a persistent protonema; capsule long-stalked; peristome single, with 16 teeth. *Discelium*. (Pf. I, 3, 508.)

Family 17. **Funariaceae.** Mostly annual or biennial mosses; capsule from erect and regular to drooping and curved or oblique; peristome none or single or double, of 16 teeth in each whorl. *Ephemerum*, *Physcomitrium*, *Funaria*. (Pf. I, 3, 509.)

Family 18. **Schizostegiaceae.** Annual mosses, with distichous, vertical leaves, which are confluent below; capsule small, without peristome. *Schizostegia*. (Pf. I, 3, 529.)

Family 19. **Drepanophyllaceae.** Small tropical mosses with distichous, equitant leaves, capsule erect, with a single peristome. *Drepanophyllum*. (Pf. I, 3, 530.)

Family 20. **Mitteniaceae.** Small Australian mosses, with thin-walled, cylindrical capsules having a double peristome of 16 teeth in each whorl. *Mittonia*. (Pf. I, 3, 532.)

Family 21. **Bryaceae.** Plants from small to large, with costate leaves; capsule pear-shaped, long-stalked, usually with a double peristome, the outer whorl of 16 teeth. *Pohlia*, *Webera*, *Brachymenium*, *Bryum*. (Pf. I, 3, 532.)

Family 22. **Leptostomataceae.** Small tropical mosses, with crowded leaves, and a rudimentary peristome. *Leptostomum*. (Pf. I, 3, 601.)

Family 23. **Mniaceae.** Rather large mosses with well-developed leaves; capsule regular, ovoid to cylindrical, mostly pendent;

peristome usually double, the outer whorl of 16 teeth. (*Mnium*, *Rhizogonium*. (Pf. I, 3, 603.)

Family 24. **Meeseaceae**. Small mosses with 3- to 8-ranked leaves; capsule long-stalked, drooping; peristome double, each whorl of 16 teeth. *Meesca*. (Pf. I, 3, 626.)

Family 25. **Aulacomniaceae**. Medium-sized mosses with drooping, oblong capsules, with a double peristome, the outer whorl of 16 teeth. *Aulacomnium*. (Pf. I, 3, 623.)

Family 26. **Bartramiaceae**. Medium-sized to large mosses, with papillose leaves; capsule spherical, drooping; peristome usually double, with 16 teeth in each whorl. *Bartramia*, *Philonotis*, *Brentelia*, *Catascopium*. (Pf. I, 3, 631.)

Family 27. **Timmiaceae**. Rather large mosses, with crowded leaves, and long-stalked capsules; peristome double, the outer whorl of 16 teeth, the inner split into 64. *Timmia*. (Pf. I, 3, 660.)

Family 28. **Polytrichaceae**. Large mosses with thick, costate leaves; capsule long-stalked, erect or drooping, cylindrical or angular; peristome single, of 32 or 64 teeth. *Catharina*, *Pogonatum*, *Polytrichum*. (Pf. I, 3, 669.)

Family 29. **Georgiaceae**. Small mosses, with erect capsules, and four-toothed peristomes. *Georgia*, *Tetradontium*. (Pf. I, 3, 667.)

Family 30. **Buxbaumiaceae**. Small, thick-leaved mosses with large, oblique capsules; peristome double, the outer rudimentary, the inner of 16 or 32 teeth. *Buxbaumia*. (Pf. I, 3, 664.)

Suborder PLEUROCARPI. Spore-fruits terminal upon short lateral axes.

Family 31. **Erpodiaceae**. Mostly slender mosses of warm climates, with upright regular capsules; peristome mostly wanting. *Erpodium*. (Pf. I, 3, 706.)

Family 32. **Hedwigiaceae**. Mostly strong-growing mosses, with many-ranked leaves; capsule erect, regular; peristome none. *Hedwigia*, *Braunia*. (Pf. I, 3, 712.)

Family 33. **Fontinalaceae**. From slender to vigorous, mostly aquatic mosses, with 3- to 5-ranked leaves; capsule erect, regular;

peristome double, single, or wanting, with 16 teeth in each whorl. *Fontinalis*, *Dichelyma*. (Pf. I, 3, 722.)

Family 34. **Climaciaceae**. Large, dendroid mosses, with erect leafy stems, from a horizontal running stem; capsule elliptical, erect or recurved; peristome double, the outer teeth united below. *Climacium*, *Girgensohnia*. (Pf. I, 3, 733.)

Family 35. **Cryphaeaceae**. From slender to vigorous mosses, mostly growing on trees with closely set leaves, and erect leaf-covered capsules; peristome mostly double, with 16 outer teeth. *Cryphaea*. (Pf. I, 3, 736.)

Family 36. **Leucodontaceae**. Mostly vigorous, rigid mosses, with erect leafy stems from a horizontal running stem; capsule erect, regular; peristome double. *Leucodon*, *Forsstroemia*. (Pf. I, 3, 747.)

Family 37. **Prionodontaceae**. Vigorous, long-leafed tropical mosses, with ovate short-stemmed capsules; peristome double, the whorls alike. *Prionodon*. (Pf. I, 3, 763.)

Family 38. **Spiridentaceae**. More or less vigorous, rigid, Australasian mosses, with erect, ovoid long-stemmed capsules; peristome mostly double. *Spiridens*. (Pf. I, 3, 765.)

Family 39. **Lepyrodontaceae**. More or less vigorous, many-leaved mosses of the southern hemisphere, with elongated, erect capsules; peristome single, of weak teeth. *Lepyrodon*. (Pf. I, 3, 771.)

Family 40. **Pleurophascaceae**. Vigorous Tasmanian ground-mosses, with crowded leaves; capsule erect, large, spheroidal; peristome none; spores large. *Pleurophascum*. (Pf. I, 3, 774.)

Family 41. **Neckeraceae**. Slender or vigorous, more or less rigid mosses, with crowded leaves; capsule erect, regular, sunken in the perichaetium; peristome single or double, rarely absent. *Pterobryella*, *Leptodon*, *Neckera*, *Forotrichum*. (Pf. I, 3, 775.)

Family 42. **Lembophyllaceae**. Slender to vigorous mosses, with crowded, many-ranked leaves; capsule ovoid, erect or cernuous, long-stalked; peristome double. *Camptochacte*, *Lembophyllum*. (Pf. I, 3, 863.)

Family 43. **Entodontaceae.** Slender to somewhat vigorous mosses, with crowded leaves; and erect, regular capsules; peristome double, rarely single. *Entodon*, *Pylaisia*. (Pf. I, 3, 870.)

Family 44. **Fabroniaceae.** Slender mosses, with mostly crowded leaves, and erect, oval or cylindrical capsules; peristome single or double. *Fabronia*. (Pf. I, 3, 899.)

Family 45. **Pilotrichaceae.** Slender to more or less vigorous mosses, with crowded leaves; capsule mostly erect, regular, sometimes surrounded by the perichaetium; peristome double. *Pilotrichum*. (Pf. I, 3, 912.)

Family 46. **Nematoceae.** Small alga-like mosses, almost leafless, with erect, short-stalked capsules; peristome double with 16 teeth in each whorl. *Ephemeroopsis*. (Pf. I, 3, 916.)

Family 47. **Hookeriaceae.** Mostly small and slender to vigorous mosses, with crowded, usually large leaves, and mostly regular, horizontal capsules; peristome double. *Hookeria*, *Pterygophyllum*. (Pf. I, 3, 918.)

Family 48. **Hypopterygiaceae.** Much-branched tropical mosses, with 2-ranked leaves; peristome double. *Hypopterygium*. (Pf. I, 3, —.)

Family 49. **Leskeaceae.** Cushion-forming mosses with crowded, many-ranked leaves; capsule symmetrical, erect or curved; peristome double. *Leskea*, *Anomodon*, *Thuidium*. (Pf. I, 3, —.)

Family 50. **Pterogoniaceae.** Cushion-forming mosses, with symmetrical capsules, and double peristomes. *Pterogonium*. (Pf. I, 3, —.)

Family 51. **Sematophyllaceae.** Tropical mosses with very small capsules; usually included in *Hypnaceae*. *Sematophyllum*. (Pf. I, 3, —.)

Family 52. **Stereodontaceae.** Non-American mosses usually included in *Hypnaceae*, but with proportionately large capsules. *Stereodon*. (Pf. I, 3, —.)

Family 53. **Hypnodendraceae.** Non-American mosses with creeping stems, which bear vertical, leafy, dendroid-branched stems, usually included in the next family. *Hypnodendron*. (Pf. I, 3, —.)

Family 54. **Hypnaceae**. Mosses of variable size and habit, with costate or ecostate leaves, which are in two or many rows; capsule long-stalked, horizontal or nodding; peristome double, of 16 outer, and as many inner teeth. *Hypnum*, *Amblystegium*, (Pf. I, 3, —.)

Phylum IX. **PTERIDOPHYTA**. The Ferns.

Chlorophyll-green, mostly terrestrial plants, exhibiting two generations in each life cycle, viz., (1) the gametophyte, which is small and short lived, and (2) the sporophyte, which is large, with roots, stems, and leaves, and long-lived. Stems of the sporophyte solid, erect or creeping; leaves usually relatively large, with broadly expanded blades and elongated petioles. The name PTERIDOPHYTA is here restricted to the ferns, alone (FILICINAE), the horsetails and lycopods having been removed to separate phyla.

Class 20. EUSPORANGIATAE. Sporangia developed from internal cells.

Order OPHIOGLOSSALES. Gametophyte tuberous, chlorophyll-less, subterranean; sporophyte with large, often compound sporophylls (leaves), certain branches of which are spore bearing.

Family 1. **Ophioglossaceae**. Stems short, erect, bearing one or few leaves. *Ophioglossum*, *Botrychium*. (Pf. I, 4, 449.)

Order MARATTIALES. Gametophyte flat, chlorophyllose, attached with rhizoids; sporophyte with large, compound sporophylls borne upon a mostly upright stem, which is rooted below; sporangia hypophyllous.

Family 2. **Marattiaceae**. Large, tropical ferns of a type now nearly extinct. *Angiopteris*, *Marattia*, *Danacia*. (Pf. I, 4, 422.)

Order ISOETALES. Gametophytes dioecious, the male rudimentary, one-celled, very small; the female larger, many-celled, but little larger than the megaspore. Sporophyte with an erect stem bearing many crowded, narrow sporophylls; sporangia epiphyllous.

Family 3. **Isoetaceae**. Medium-sized to small aquatic plants with a rush-like aspect, the sporangia sunken in the upper tissues of the leaf-bases. *Isoetes*. (Pf. I, 4, 756.)

Class 21. LEPTOSPORANGIATAE. Sporangia developed from superficial cells.

Order FILICALES. Spores of one kind; sporangia mostly with an annulus (ring); gametophytes monoecious, foliose.

Family 4. **Osmundaceae**. Sporangia globose, mostly stalked, with but a trace of a ring, splitting vertically. *Osmunda*. (Pf. I, 4, 372.)

Family 5. **Schizaeaceae**. Sporangia ovate or subglobose, sessile, with an apical horizontal ring, splitting vertically. *Schizaea*, *Lygodium*. (Pf. I, 4, 356.)

Family 6. **Gleicheniaceae**. Sporangia globose, sessile, with a horizontal ring, splitting vertically. *Gleichenia*. (Pf. I, 4, 350.)

Family 7. **Matoniaceae**. Sporangia compressed, sessile, or short-stalked, with an oblique ring, splitting obliquely. *Matonia*. (Pf. I, 4, 343.)

Family 8. **Parkeriaceae**. Sporangia globose, sessile with a vertical ring; splitting transversely. Aquatic ferns natives of the tropics. *Ceratopteris*. (Pf. I, 4, 339.)

Family 9. **Cyatheaceae**. Sporangia compressed, sessile on a low involucrate receptacle on the leaf surface; ring vertical or oblique, splitting transversely. *Dicksonia*, *Cyathea*, *Alsophila*. (Pf. I, 4, 113.)

Family 10. **Hymenophyllaceae**. Sporangia compressed, sessile upon an elongated involucrate, marginal receptacle; ring horizontal or oblique, splitting vertically. *Hymenophyllum*, *Trichomanes*. (Pf. I, 4, 91.)

Family 11. **Polypodiaceae**. Sporangia compressed, mostly stalked, collected into sori, which are often covered or surrounded by an involucre (indusium); ring vertical, splitting transversely. *Polypodium*, *Asplenium*, *Nephrodium*, *Adiantum*, *Pteridium*. (Pf. I, 4, 139.)

Order HYDROPTERIDALES. Spores of two kinds, microspores and megaspores; sporangia without an annulus, male gametophytes one-celled, minute; female gametophytes larger, many-celled, but little larger than the megaspore.

Family 12. **Marsiliaceae**. Perennial plants rooted in the mud

with creeping stems which bear filiform or long petioles and 4-parted leaves. *Marsilia, Pilularia*. (Pf. I, 4, 403.)

Family 13. **Salviniaceae**. Very small, floating, annual plants, with horizontal stems which bear minute distichous leaves. *Azolla, Salvinia*. (Pf. I, 4, 383.)

Phylum X. **CALAMOPHYTA**. The Hórsetails.

Chlorophyll-green, terrestrial plants, exhibiting two generations in each life cycle, viz., (1) the gametophyte, which is small, and short-lived, and (2) the sporophyte, which is large, with roots, stems, and leaves, and long-lived. Stems of the sporophyte solid or hollow, jointed, erect or creeping; leaves whorled, relatively small. This phylum has almost become extinct, being represented today by but a single genus of 24 species.

Class 22. SPHENOPHYLLINEAE. Palaeozoic plants of tree-like aspect and dimensions, long since extinct. Stems solid, jointed, with a central triarch, fibrovascular bundle, and bearing relatively small, wedge-shaped leaves. Sporophylls in cones, each sporophyll with one or two isosporous sporangia.

Order SPHENOPHYLLALES. With the characters of the class.

Family 1. **Sphenophyllaceae**. Known only from fossil specimens. *Sphenophyllum*. (Pf. I, 4, 515.)

Class 23. EQUISETINEAE. Palaeozoic to recent plants, mostly extinct. Stems hollow, jointed, with a circular row of collateral fibro-vascular bundles; leaves very small, narrow, and united into a sheath (in recent forms, larger in Mesozoic forms). Sporophylls peltate, in close terminal cones, each sporophyll with several pendent, isosporous sporangia.

Order EQUISETALES. With the characters of the class.

Family 2. **Equisetaceae**. Including but one living genus, *Equisetum*, which has survived from the Carboniferous period, and several extinct genera, *Equisetites, Phyllothecca*, and others. (Pf. I, 4, 520.)

Class 24. CALAMARINEAE. Palaeozoic plants, often of tree-like aspect and dimensions, long since extinct. Stems hollow, jointed with a circular row of collateral fibrovascular bun-

dles, increasing in diameter by a cambial zone. Leaves mostly narrow, distinct. Sporophylls in cones, each sporophyll with one or more heterosporous sporangia.

Order CALAMARIALES. With the characters of the class.

Family 3. **Protocalamariaceae.** Leaves large, forked. *Asterocalamites*. (Pf. I, 4, 588.)

Family 4. **Calamariaceae.** Leaves narrow, entire. *Calamodendron*, *Eucalamites*, *Calamostachys*, *Huttonia*. (Pf. I, 4, 551.)

Phylum XI. **LEPIDOPHYTA.** The Lycopods.

Chlorophyll-green, terrestrial plants, exhibiting two generations in each life cycle, viz., (1) the gametophyte, which is small and short-lived, and (2) the sporophyte, which is large, with roots, stems, and leaves, and long-lived. Stems of the sporophyte solid, not jointed, erect or creeping; leaves relatively small, scattered or crowded upon the stem.

Class 25. **ELIGULATAE.** Leaves without ligules; spores uniform (isosporous).

Order LYCOPODIALES. Gametophyte much larger than the spore; sporophyte with a central fibrovascular bundle.

Family 1. **Lycopodiaceae.** Sporophylls undivided; sporangia single; leafy, branching evergreen plants. *Lycopodium*, *Phylloglossum*. (Pf. I, 4, 563.)

Family 2. **Psilotaceae.** Sporophylls bifid; sporangia 2 or 3; pale saprophytes or parasites with leafy, or almost leafless stems. *Tmesipteris*, *Psilotum*. (Pf. I, 4, 606.)

Class 26. **LIGULATAE.** Leaves with ligules; spores of two kinds (heterosporous).

Order SELAGINELLALES. Sporophyte stem with a central fibrovascular bundle, incapable of thickening.

Family 3. **Selaginellaceae.** Moss-like plants with slender dichotomously branched stems, and the sporophylls in more or less well-defined terminal cones. *Selaginella*. (Pf. I, 4, 621.)

Order LEPIDOPHYTALES. Sporophyte stem with a central fibrovascular bundle, and thickening by a cortical meristem. Palaeozoic and Mesozoic trees, long since extinct.

Family 4. **Lepidodendraceae.** Leaf-scars large, rhomboidal, crowded together. *Lepidodendron*, *Lepidophlois*. (Pf. I, 4, 717.)

Family 5. **Bothrodendraceae.** Leaf-scars small, ovate, widely separated. *Bothrodendron*. (Pf. I, 4, 739.)

Family 6. **Sigillariaceae.** Leaf-scars medium-sized, ovate-angled, less widely separated, but not in contact. *Sigillaria*. (Pf. I, 4, 740.)

Family 7. **Pleuromoiaceae.** Leaf-scars medium-sized, regularly ovate, or much elongated, less widely separated, but not in contact. *Pleuromoia*. (Pf. I, 4, 754.)

Phylum XII. **CYCADOPHYTA.** The Cycads.

Chlorophyll-green terrestrial plants in which the alternation of generations is obscured by the reduction of the gametophyte to a condition of dependence upon the long-lived, leafy-stemmed sporophyte. Spores of two kinds (heterosporous), borne on sporophylls which occur in strobili, the microspores set free, the megaspores retained in their sporangia, where they develop gametophytes and archegones; after fecundation of the egg by the motile spermatozooids, the embryo sporophyte surrounded by the gametophyte tissue embedded in the 1- or 2-coated sporangium constitutes the "seed."

Class 27. **CYCADOFILICES** (*Pteridospermae*). Palaeozoic plants, long extinct, related to the ferns on the one hand, and the following classes on the other. Stems short and erect, increasing in thickness, bearing pinnate leaves.

Family 1. **Lyginopterideae.** With stems which seem to have had the power of increasing in diameter by the growth of their collateral bundles. *Lyginopteris*, *Megaloxylon*, *Calamopitys*. (Pf. I, 4, 783.)

Family 2. **Medulloseae**, related to the preceding. *Medullosa*, *Steloxylon*. (Pf. I, 4, 788.)

Family 3. **Cladoxyleae**, including *Cladoxylon* and *Trochelia*. (Pf. I, 4, 782.)

Family 4. **Protopyteae**, including *Protopytis*. (Pf. I, 4, 794.)

Family 5. **Araucarioxyleae**, including *Araucarioxylon*. (Pf. I, 4, 795.)

Class 28. **CORDAITINEAE**. Palaeozoic plants, long extinct, related to the modern cycads, and probably also to the conifers, of which indeed they may have been the ancestors. Branching trees, bearing large parallel-veined leaves; seeds with two integuments.

Family 6. **Cordaitaceae**. Tall trees (20–30 m. high) bearing subterminal clusters of thick, spirally-arranged, leathery leaves, sometimes as much as 1 m. long, and 2 dm. wide. *Cordaites*, *Dadoxylon*, *Artisia*. (Pf. II, 1, 26.)

Class 29. **BENNETTITINEAE**. Mesozoic plants, long extinct, related on the one hand to the ancient cycads, and on the other to the flowering plants, of which they are thought by some, with very good reasons, to have been the ancestors. Stems simple, erect, increasing in thickness by annular growth of fibrovascular tissue; leaves pinnate; sporophylls in terminal amphisporengiate strobili.

Family 7. **Bennettitaceae**. Short-stemmed plants with the main axis terminated by a strobilus of sporophylls, the lower sterile and long, the next bearing many microsporangia, and the uppermost megasporangia. *Bennettites*. (Wieland, American Fossil Cycads; Engler's Syllabus, 73.)

Class 30. **CYCADINEAE**. Plants with erect, woody, little-branched stems, bearing terminal clusters of pinnate leaves. The collateral fibrovascular bundles are arranged concentrically in the stem; these increase the thickness of the stem by development of their cambium, and also by the formation of new bundles in the cortical meristem. Sporophylls in dioecious strobili. Many cycads which existed in Mesozoic times have become extinct, leaving only a few genera and species in the present.

Family 8. **Cycadaceae**. Mostly tropical trees of the present time, with a fern-like or palm-like aspect. *Cycas*, *Dioon*, *Encephalartos*, *Macrozamia*, *Zamia*, *Ccratozamia*. (Pf. II, 1, 6.)

Class 31. **GINKGOINEAE**. Plants with erect, woody, freely-branched stems, bearing fan-shaped, parallel-veined leaves; the

collateral fibrovascular bundles are arranged concentrically in the stem, and these increase its thickness by the development of their cambium; sporophylls in dioecious strobili.

Family 9. **Ginkgoaceae**. Represented today by a single species of *Ginkgo*, a large Chinese and Japanese tree, but in the Tertiary there were many species of this genus, and of other now wholly extinct genera. (Pf. II, 1, 108.)

?Phylum XIII. **GNETALES?** The Joint-Firs.

Chlorophyll-green terrestrial plants, shrubby in size and structure, with a branched or simple stem, undivided leaves, monoecious sporophylls, and naked seeds. They are related to the Cycads, and possibly should be included in that phylum.

Class 32. **GNETINEAE**. With the characters of the phylum. Three genera, little if at all related, compose this phylum, if indeed it be a phylum. They are usually referred to a common family, *Gnetaceae*, with no good reason. The species of *Ephedra* (about 20) are low evergreen shrubs, bearing opposite, reduced leaves, and axillary clusters of simple, diclinous flowers. *Tumboa* (1 species) is a genus of thick-stemmed woody plants, with two long strap-shaped, opposite leaves, and bearing their simple flowers in very regular, scaly cones. *Gnetum* contains about fifteen species of shrubs, bearing opposite, large, elliptical leaves, and loose terminal scaleless cones. (Pf. II, 1, 116.)

Phylum XIV. **STROBILOPHYTA**. The Conifers.

Chlorophyll-green terrestrial, woody plants, usually trees of large size, in which the alternation of generations is obscured by the reduction of the gametophyte to a condition of dependence upon the long-lived, leafy-stemmed sporophyte. Spores of two kinds (heterosporous), borne on sporophylls which occur in strobili, the microspores set free (as "pollen"), the megaspores retained in their sporangia, where they develop gametophytes and archegones. After fecundation of the egg by non-motile spermatozoids (male nuclei) the embryo sporophyte, surrounded by the

gametophyte tissue (endosperm), embedded in the 1- or 2-coated sporangium, constitutes the seed. Sporophyte stems with collateral fibrovascular bundles in a circular row, and increasing in diameter by a cambial zone.

In this phylum the primitive seed-bearing strobilus of the *Taxodiaceae* became more complex in the line of development through *Araucariaceae* to *Abietaceae*, while it became simpler and smaller in the line through *Cupressaceae*, to *Podocarpaceae* and *Taxaceae*.

Class 33. PINOIDEAE. With the characters of the phylum.

Order CONIFERALES. Both microsporophylls and megasporophylls in strobili, usually monoecious.

Family 1. **Taxodiaceae.** Large to very large trees, mostly evergreen; each microsporophyll with 2 to 8 sporangia; each megasporophyll eventually woody, with 2 to 8 axillary and erect sporangia (seeds), or superficial and inverted; trees, monoecious. *Sequoia*, *Arthrotaxis*, *Taxodium*. (Pf. II, 1, 84.) This is a very old family, most living genera having fossil representatives, which in some cases lived as long ago as the Coal Period. In addition to these, many genera which formerly existed have become wholly extinct.

Family 2. **Araucariaceae.** Large trees of the southern hemisphere, all evergreen; each microsporophyll with 5 to 15 sporangia; each megasporophyll, eventually woody, with one inverted sporangium (seed); "seed scale" rudimentary or wanting; trees mostly dioecious. *Agathis*, *Araucaria*. (Pf. II, 1, 66.) Many fossil species of the two living genera are known, and in addition some fossils have been referred to genera now extinct.

Family 3. **Abietaceae.** Large trees of both hemispheres, mostly evergreen; each microsporophyll with two sporangia; each megasporophyll develops a woody "seed scale" which bears two inverted sporangia (seeds); trees monoecious. *Pinus*, *Larix*, *Picea*, *Abies*. (Pf. II, 1, 69.) Many fossil species of most of the living genera are known from the later geological periods.

Family 4. **Cupressaceae.** Large evergreen trees of the northern hemisphere; each microsporophyll with 4 to 8 sporangia; each megasporophyll shield-shaped, woody, bearing one to many sporangia (seeds); no "seed scale"; trees, monoecious. *Cupres-*

sus, *Chamaccyparis*. (Pf. II, 1, 99.) Fossil species of living and extinct genera of this family are known from the later geological periods.

Family 5. **Thuyopsidaceae**. Large evergreen trees of both hemispheres, with mostly scale-like leaves; microsporophylls with 3 to 5 sporangia; megasporophylls scale-shaped, woody, each with one to many sporangia (seeds); no "seed scale." *Callitris*, *Libocedrus*, *Thuja*. (Pf. II, 1, 92, and 95.) A few fossil species of living and extinct genera of this family are known from the later geological periods.

Family 6. **Juniperaceae**. Evergreen trees or shrubs of the northern hemisphere, with scale-like or spreading leaves; microsporophylls each with 4 to 8 sporangia; megasporophylls scale-shaped, eventually fleshy and adherent into a berry-like strobilus, each sporophyll bearing one to two seeds. *Juniperus*. (Pf. II, 1, 101.) Fossil species from the later geological periods have been referred to this genus.

Order TAXALES. Microsporophylls in strobili but the megasporophylls mostly single.

Family 7. **Podocarpaceae**. Evergreen trees, mostly of the southern hemisphere, bearing their 2-sporangiate microsporophylls in strobili; megasporophylls in small strobili, or solitary, each bearing one, usually inverted, sporangium (seed). *Podocarpus*, *Dacrydium*. (Pf. II, 1, 103.)

Family 8. **Phyllocladaceae**. Evergreen trees of the southern hemisphere, bearing their 2-sporangiate microsporophylls in strobili; megasporophylls solitary, or loosely clustered, not in strobili, each circularly enclosing the single erect sporangium (seed). *Phyllocladus*. (Pf. II, 1, 108.)

Family 9. **Taxaceae**. Evergreen trees or shrubs of both hemispheres, bearing their 3- to 5-sporangiate microsporophylls in strobili; megasporophylls solitary, each circularly enclosing one or two erect sporangia (seeds). *Cephalotaxus*, *Torreya*, *Taxus*. (Pf. II, 1, 107.)

Phylum XV. **ANTHOPHYTA.** The Flowering Plants.

Typically chlorophyll-green plants (a few colorless hystero-phytes), ranging from small or even minute plants to great trees a hundred or more meters in height; alternation of generations obscured by the extreme reduction of the gametophyte to a condition of dependence upon the long-lived, leafy-stemmed sporophyte. Spores of two kinds (heterosporous), produced on sporophylls which are borne in modified, often much reduced strobili (flowers); microsporophylls (stamens) normally with two sporangia (pollen sacs); the microspores being set free (as "pollen") when mature; megasporophylls folded lengthwise (constituting the "pistil"), enclosing the sporangia (ovules) in, which the megaspores remain and develop the minute gametophyte; archegones very much reduced, including little more than the egg, which is fecundated by the non-motile spermatozoids (male nuclei), resulting in the formation of an embryo sporophyte; megasporangia surrounded by one or two enveloping coats (seed coats); mature seed with or without endosperm (gametophyte tissue).

The Flowering Plants are here held to have sprung from strobiliferous ancestors probably of the type of the *Bennettitaceae*, and as a consequence those Anthophyta are considered to be primitive in which the sporophylls are many and distinct. Symphyllly and syncarpy are later structural conditions than apophyly and apocarpy. So also, fewer sporophylls in the anthostrobilus is a later condition derived from the earlier polyphyllous structure. The symphysis of sporophylls is a mode of evolution, and so is their aphanisis.

Class 33. **MONOCOTYLEDONEAE.** Leaves of young sporophore alternate; leaves of mature sporophore usually parallel-veined; fibro-vascular bundles of the stem scattered, usually not arranged in rings.

Order **ALISMALES.** Pistils separate, superior to all other parts of the flower.

Family 1. **Alismataceae.** Aquatic or paludose herbs with mostly radical, often large leaves; flowers small to large; peri-

anth in two whorls of three leaves each (calyx and corolla). *Alisma*, *Sagittaria*. (Pf. II, 1, 227.)

Family 2. **Butomaceae**. Aquatic or paludose herbs, bearing narrow or broad leaves, with convergent veins; perianth in two whorls, of three leaves each (calyx and corolla). *Butomus*, *Limnocharis*. (Pf. II, 1, 232.)

Family 3. **Triuridaceae**. Very small, pale, leafless plants growing in wet places in tropical countries. *Triuris*. (Pf. II, 1, 235.)

Family 4. **Scheuchzeriaceae**. Aquatic or paludose herbs with rush-like leaves, and small flowers, with a two-whorled perianth, each 4 to 6 parted. *Triglochin*, *Scheuchzeria*. (Pf. II, 1, 222.)

Family 5. **Aponogetonaceae**. Aquatic plants with petioled, oblong, translucent leaves, with convergent veins; flowers small, spicate. *Aponogeton*. (Pf. II, 1, 218.)

Family 6. **Naiadaceae**. Slender, branching wholly submerged aquatics, with sheathing, mostly opposite leaves, and monoecious or dioecious flowers. *Najas*. (Pf. II, 1, 214.)

Family 7. **Potamogetonaceae**. Aquatic or paludose herbs with mostly alternate stem-leaves; flowers mostly small and inconspicuous; perianth none, or of 1 to 6 leaves in 1 or 2 whorls. *Potamogeton*, *Zostera*, *Zannichellia*. (Pf. II, 1, 194.)

Order LILIALES. Pistils united (usually 3), forming a compound pistil, superior; flower leaves (usually 6, in two whorls) delicate and corolla-like.

Family 8. **Liliaceae**. Pistil mostly 3-celled; stamens 6; perianth of two similar whorls, each of three similar leaves. *Lilium*, *Erythronium*, *Tulipa*, *Yucca*, *Asparagus*, *Allium*. (Pf. II, 5, 10.)

Family 9. **Stemonaceae**. Pistil 1-celled; stamens 4; perianth of two similar whorls, each of two similar leaves. *Stemona*, *Croonia*. (Pf. II, 5, 8.)

Family 10. **Pontederiaceae**. Aquatic herbs with 3- or 1-celled pistil; stamens 6 or 3; perianth of two similar whorls, each of three similar or dissimilar leaves. *Pontederia*, *Heteranthera*. (Pf. II, 4, 70.)

Family 11. **Cyanastraceae.** Tropical African rhizomatous plants. *Cyanastrum*. (Syllabus, 96.)

Family 12. **Philydraceae.** Pistil 3-celled; stamen 1; perianth of two similar whorls, each of two dissimilar leaves. *Philydrium*. (Pf. II, 4, 75.)

Family 13. **Xyridaceae.** Rush-like plants with a 1-celled or incompletely 3-celled pistil; stamens 3; perianth of two dissimilar whorls each of three similar leaves. *Xyris*. (Pf. II, 4, 14.)

Family 14. **Mayaceae.** Slender, creeping, moss-like plants with 1-celled pistil; stamens 3; perianth of two dissimilar whorls, each of three similar leaves. *Mayaca*. (Pf. II, 4, 16.)

Family 15. **Commelinaceae.** Succulent herbs with 3- or 2-celled pistil; stamens 6; perianth of two dissimilar whorls of three similar leaves. *Commelina*, *Tradescantia*. (Pf. II, 4, 60.)

Family 16. **Rapateaceae.** Tall, sedge-like marsh herbs with 3-celled pistil; stamens 6, in pairs; perianth of two dissimilar whorls, each of three similar leaves. *Rapatea*. (Pf. II, 4, 28.)

Family 17. **Juncaceae.** Herbs with narrow leaves; pistil 1- to 3-celled; ovules solitary or many; fruit a dry 3-valved pod. *Juncus*, *Luzula*. (Pf. II, 5, 1.)

Family 18. **Eriocaulonaceae.** Rush-like herbs with flowers in close heads; perianth segments 6 or less, small; pistil 3- or 2-celled; ovules orthotropous, pendulous. *Eriocaulon*. (Pf. II, 4, 21.)

Family 19. **Thurniaceae.** South American herbs, with small, 1-nerved leaves, and small axillary flowers. *Thurnia*. (Syllabus, 94.)

Family 20. **Flagellariaceae.** Erect or climbing herbs with long narrow leaves; pistil 3-celled; ovules solitary; fruit a 1- to 2-seeded berry. *Flagellaria*. (Pf. II, 4, 1.)

Order ARALES. Compound pistil, mostly tricarpeal, superior; ovules more than one; flower-leaves reduced to scales or entirely wanting.

Family 21. **Pandanaceae.** Shrubs or trees with spirally crowded, narrow, stiff leaves on the ends of the branches; pistil 1-celled; ovules one or many. *Pandanus*. (Pf. II, 1, 186.)

Family 22. **Cyclanthaceae**. Mostly herbaceous plants with broad, petioled leaves having parallel venation; pistil 1-celled; ovules many, on four parietal placentae. *Cyclanthus*. (Pf. II, 3, 93.)

Family 23. **Araceae**. Mostly herbaceous plants with broad, petioled leaves, having reticulate venation; pistil 1- to 4-celled; ovules 1 or more. *Anthurium*, *Acorus*, *Monstera*, *Symplocarpus*, *Calla*, *Philodendron*, *Calocasia*, *Caladium*, *Arum*, *Arisaema*. (Pf. II, 3, 102.)

Family 24. **Sparganiaceae**. Aquatic or paludose plants with creeping rootstocks and erect stems, bearing linear leaves; flowers monoecious in dense globose heads. *Sparganium*. (Pf. II, 1, 192.)

Family 25. **Typhaceae**. Aquatic or paludose herbs, with linear, sheathing leaves; pistil 1-celled; ovule 1. *Typha*. (Pf. II, 1, 183.)

Family 26. **Lemnaceae**. Very small, floating, aquatic herbs; pistil 1-celled; ovules 1 or more. *Lemna*, *Spirodela*. (Pf. II, 3, 154.)

Order PALMALES. Compound pistil mostly tricarpellary, superior; ovules usually one; flower-leaves reduced to rigid or herbaceous scales.

Family 27. **Palmaceae**. Trees or shrubs with compound leaves; pistil 1- to 3-celled; fruit a 1-seeded berry or drupe (rarely 2- to 3-seeded). *Phoenix*, *Chamacrops*, *Calamus*, *Oreodoxa*, *Cocos*. (Pf. II, 3, 1.)

Order GRAMINALES. Compound pistil reduced to 2 or 3 carpels; ovule solitary; perianth reduced to small scales or entirely wanting.

Family 28. **Centrolepidiaceae**. Small rush-like herbs with flowers in spikes or heads; perianth none; pistil 1- to 3-celled; ovules orthotropous, pendulous. *Centrolepis*. (Pf. II, 4, 11.)

Family 29. **Restionaceae**. Rush-like herbs or undershrubs, with spiked, racemed, or paniced flowers; perianth segments 6 or less, chaffy; pistil 1- to 3-celled; ovules orthotropous, pendulous. *Restio*. (Pf. II, 4, 3.)

Family 30. **Cyperaceae**. Grass-like herbs with 3-ranked leaves; perianth segments bristly or none; pistil 1-celled; ovules anatropous, erect. *Cyperus*, *Scirpus*, *Fimbristylis*, *Rhynchospora*, *Carex*. (Pf. II, 2, 98.)

Family 31. **Gramineae**. Mostly erect herbs with hollow, jointed stems, and 2-ranked leaves; perianth segments of 2 to 6 thin scales or none; pistil 1-celled; ovules anatropous, ascending. *Bambusa*, *Bromus*, *Triticum*, *Bouteloua*, *Avena*, *Agrostis*, *Phalaris*, *Oryza*, *Panicum*, *Andropogon*, *Zea*. (Pf. II, 2, 1.)

Order HYDRALES. Compound tricarpellary pistil, inferior to all other parts of the flower; flower-leaves in each whorl alike in shape (flower regular); seeds without endosperm.

Family 32. **Hydrocharitaceae**. Small aquatic herbs mostly inhabiting the fresh waters of temperate climates. *Vallisneria*, *Hydrocharis*, *Elodea*. (Pf. II, 1, 238.)

Order IRIDALES. Compound tricarpellary pistil, inferior; flower-leaves in each whorl mostly alike in shape (flower regular); seeds with endosperm.

Family 33. **Amaryllidaceae**. Leaves narrow, or the blade broad, with longitudinal veins; pistil 3-celled; ovules many; stamens 6 or 3. *Amaryllis*, *Crinum*, *Narcissus*, *Agave*, *Hypoxis*. (Pf. II, 5, 97.)

Family 34. **Haemodoraceae**. Leaves sword-shaped; pistil 3-celled; ovules 1 to many; stamens 6. *Haemodorum*. (Pf. II, 5, 92.)

Family 35. **Iridaceae**. Leaves sword-shaped; pistil 3-celled; ovules many; stamens 3. *Crocus*, *Iris*, *Tigridia*, *Sisyrinchium*, *Ixia*, *Tritonia*, *Gladiolus*, *Freesia*. (Pf. II, 5, 137.)

Family 36. **Velloziaceae**. Woody-stemmed leafy plants, with a 3-celled pistil containing many ovules, stamens 6 or more. *Vellozia*. (Pf. II, 5, 125.)

Family 37. **Taccaceae**. Stemless herbs, with broad pinnately parallel veined leaves; pistil 1-celled; ovules many; stamens 6. *Tacca*. (Pf. II, 5, 127.)

Family 38. **Dioscoreaceae**. Mostly twining herbs with broad, petioled, longitudinally-veined leaves; pistil 3-celled; ovules 2 in each cell; stamens 6. *Dioscorea*, *Testudinaria*. (Pf. II, 5, 130.)

Family 39. **Bromeliaceae.** Leaves mostly rosulate: external perianth whorl calycine; pistil 3-celled; ovules many; stamens 6. *Tillandsia, Dendropogon, Ananas.* (Pf. II, 4, 32.)

Family 40. **Musaceae.** Large herbs, the stem often composed of the sheathing leaf-bases; perianth petaloid of 6, often dissimilar segments; stamens 6; pistil 3-celled; ovules 1 to very many. *Strelitzia, Musa.* (Pf. II, 6, 1.)

Family 41. **Zingiberaceae.** Perennial, medium sized herbs, with creeping or tuberous rootstocks; perianth irregular; stamen 1, anther 2-celled, with several "staminodes"; pistil 3-celled; ovules 1 or more in each cell. *Curcuma, Zingiber, Amomum.* (Pf. II, 6, 10.)

Family 42. **Cannaceae.** Perennial herbs of medium size, with simple pinnately-veined leaves; perianth irregular; stamen 1, anther 1-celled, with several "staminodes"; pistil 3-celled; ovules 1 to many. *Canna.* (Pf. II, 6, 30.)

Family 43. **Marantaceae.** Perennial herbs of variable habit, leaves parallel or pinnately-veined; perianth irregular: functional stamen 1, with several "staminodes"; pistil 3-celled; ovules 1 in each cell. *Calathca, Maranta.* (Pf. II, 6, 33.)

Order ORCHIDALES. Compound tricarpellary pistil, inferior; flower-leaves in each whorl mostly unlike in shape (flower irregular); seeds without endosperm.

Family 44. **Burmanniaceae.** Flowers irregular; stamens 3 or 6. *Burmannia.* (Pf. II, 6, 44.)

Family 45. **Orchidaceae.** Flowers irregular; stamens 1 or 2. *Cypripedium, Orchis, Platanthera, Vanilla, Spiranthes.* (Pf. II, 6, 52.)

Class 34. DICOTYLEDONEAE. The Dicotyledons. Leaves of young sporophore opposite; leaves of mature sporophore usually reticulate-veined; fibro-vascular bundles of the stems in one or more rings.

Subclass THALAMIFLORAE. Outer whorl (calyx) usually of separate leaves (sepals), and with the other parts of the flower inserted on the flower-axis (thalamus). This subclass has much in common with the Alismales, and also with the Calyciflorae. In

fact, these three groups appear to diverge from a common point of origin.

Order RANALES. Pistils 1 to many, monocarpellary (or rarely united); stamens generally indefinite; embryo mostly small, in copious endosperm.

Family 46. **Ranunculaceae**. Petals present, in one whorl, or absent; sepals deciduous; mostly herbs with alternate leaves. *Myosurus*, *Ranunculus*, *Anemone*, *Clematis*. (Pf. III, 2, 43.)

Family 47. **Lardizabalaceae**. Petals and sepals 6 each; stamens 6; twining or erect shrubs, with alternate leaves. *Akebia*, *Lardisabala*. (Pf. III, 2, 67.)

Family 48. **Berberidaceae**. Petals usually present, in 1 to 3 whorls; pistil 1 (rarely more), with many ovules; mostly shrubs with alternate leaves and perfect flowers. *Podophyllum*, *Berberis*. (Pf. III, 2, 70.)

Family 49. **Menispermaceae**. Petals present, in 2 whorls; twining shrubs with alternate leaves and small declivous flowers. *Menispermum*, *Cocculus*. (Pf. III, 2, 78.)

Family 50. **Magnoliaceae**. Petals present, in one to many whorls; receptacle usually elongated; shrubs and trees with alternate leaves and usually large flowers. *Magnolia*, *Liriodendron*. (Pf. III, 2, 12.)

Family 51. **Nymphaeaceae**. Petals present, in 1 to many whorls; pistils several or united; aquatic herbs with floating leaves. *Victoria*, *Castalia*, *Nymphaca*, *Nelumbo*. (Pf. III, 2, 1.)

Family 52. **Ceratophyllaceae**. Aquatic herbs with verticillate, divided leaves; flowers dioecious; perianth 0; pistil 1-celled, 1-ovuled; endosperm 0. *Ceratophyllum*. (Pf. III, 2, 10.)

Family 53. **Trochodendraceae**. Trees and shrubs with naked flowers, many stamens, and a single whorl of 2 to many partly inferior pistils. *Trochodendron*. (Pf. III, 2, 21.)

Family 54. **Cercidiphyllaceae**. Trees with naked flowers, many stamens, and a single whorl of superior pistils. *Cercidiphyllum*. (Pf. III, 2, 21.)

Family 55. **Calycanthaceae**. Petals present, in many whorls; seeds without endosperm; shrubs with opposite leaves. *Calycanthus*. (Pf. III, 2, 92.)

Family 56. **Lactoridaceae.** Much-branched shrubs of the South Pacific Islands, with alternate leaves, and apetalous flowers. *Lactoris*. (Pf. III, 2, 19.)

Family 57. **Anonaceae.** Petals present, in two whorls of 3 each; endosperm ruminated; trees or shrubs with alternate leaves. *Asimina*, *Anona*. (Pf. III, 2, 23.)

Family 58. **Myristicaceae.** Petals absent; pistil 1 (or a second rudiment), 1-seeded; endosperm ruminated; trees or shrubs with alternate leaves and small, inconspicuous, dioecious flowers. *Myristica*. (Pf. III, 2, 40.)

Family 59. **Gomortegaceae.** Large trees of South America, with opposite evergreen leaves, and acyclic flowers; pistils 2-3, each with 1 ovule. *Gomortega*. (Pf. Nach. 172.)

Family 60. **Monimiaceae.** Petals absent; pistils many, 1-ovuled embedded in the receptacle; trees and shrubs with opposite or whorled leaves, and dichinous flowers. *Kibara*, *Monimia*, *Siparuna*. (Pf. III, 2, 94.)

Family 61. **Lauraceae.** Aromatic trees and shrubs with alternate simple leaves; disk 0; petals 0; ovule 1, pendulous; endosperm 0. *Cinnamomum*, *Persea*, *Ocotea*, *Umbellularia*, *Sassafras*, *Litsea*, *Laurus*. (Pf. III, 2, 106.)

Family 62. **Leitneriaceae.** Shrubs with alternate leaves and dioecious flowers in catkins; perianth minute or 0; pistil 1-celled, 1-ovuled; endosperm minute. *Leitneria*. (Pf. III, 1, 28.)

The following families contain plants which are to be regarded as representing reduced types of the Order *Ranales*:

Family 63. **Saururaceae.** Rhizomatous, marsh herbs, with alternate leaves; perianth none; pistil of 3 to 5 carpels, more or less united. *Saururus*. (Pf. III, 1, 1.)

Family 64. **Piperaceae.** Herbs, shrubs, and trees with alternate (or opposite) leaves; flowers perfect or dichinous, mostly spicate; perianth 0; pistil 1-celled, 1-ovuled; endosperm present. *Piper*, *Macropiper*. (Pf. III, 1, 3.)

Family 65. **Chloranthaceae.** No perianth whatever; pistil 1, with 1 ovule; mostly trees and shrubs, with opposite leaves, and small flowers. *Chloranthus*. (Pf. III, 1, 12.)

Family 66. **Lacistemaceae.** Shrubs and trees with alternate leaves; perianth 0; stamen 1; pistil 3- or 2-carpellary. *Lacistema*. (Pf. III, 1, 14.)

Order RHOEADALES. Pistil of 2 or more united carpels, mostly 1-celled, with parietal placentae; stamens indefinite or definite; endosperm none or copious.

Family 67. **Papaveraceae.** Mostly milky-juiced plants, with alternate leaves; sepals 2-3; petals 4 or more (or 0); stamens indefinite; pistil many-carpellary. *Eschscholtzia*, *Sanguinaria*, *Argemone*, *Papaver*, *Bicuculla*, *Fumaria*. (Pf. III, 2, 130.)

Family 68. **Capparidaceae.** Herbs, shrubs, and trees with alternate or opposite leaves; sepals 4; petals 4 (or 0); stamens 4 (or many); pistil 2- to 6-carpellary. *Cleome*, *Capparis*. (Pf. III, 2, 209.)

Family 69. **Cruciferae.** Herbs, rarely shrubs, with alternate (or opposite) leaves; sepals 4; petals 4; stamens 6 or 4; pistil 2-carpellary. *Sinapis*, *Brassica*, *Raphanus*, *Bursa*, *Alyssum*. (Pf. III, 2, 145.)

Family 70. **Tovariaceae.** Annual herbs of the tropics, with alternate leaves; 8-merous flowers. *Tovaria*. (Pf. III, 2, 207.)

Family 71. **Resedaceae.** Herbs and shrubs with scattered leaves; sepals 4-8 (or 2 or 0); stamens 3-40; pistil 2- to 6-carpellary. *Reseda*. (Pf. III, 2, 237.)

Family 72. **Moringaceae.** Trees of the tropics, with compound leaves and pentamerous flowers, and producing bean-like pods. *Moringa*. (Pf. III, 2, 242.)

Order SARRACENIALES. Pistil of 3 to 5 carpels united; placentae parietal or central; seeds indefinite; herbs with "insectivorous" leaves.

Family 73. **Sarraceniaceae.** Herbs with pitcher-shaped leaves; sepals 4-5; petals 5-0; stamens indefinite; pistil 3-5-carpellary. *Sarracenia*, *Darlingtonia*. (Pf. III, 2, 244.)

Family 74. **Nepenthaceae.** Tropical undershrubs with pitcher-shaped leaves; sepals 4 or 3; petals 0; stamens 4-16; pistil 4- to 3-carpellary. *Nepenthes*. (Pf. III, 2, 253.)

Family 75. **Droseraceae.** Gland-bearing marsh herbs; stamens mostly definite; pistil syncarpous, 1- to 3-celled, superior;

ovules many, on basal, axile, or parietal placentae. *Drosera*, *Dionaea*. (Pf. III, 2, 261.)

Order CARYOPHYLLALES. Pistil usually of 3. or more united carpels, mostly 1-celled, with a free central placentae, and many ovules (sometimes reduced to a one-celled, one-ovuled ovary); stamens as many or twice as many as the petals; seeds endospermous, usually with a curved embryo.

Family 76. **Caryophyllaceae**. Herbs (and shrubs) with opposite leaves; petals 3-5, stalked or not; ovules many on a central placenta. *Silene*, *Lychnis*, *Dianthus*, *Alsine*, *Paronychia*, *Illecebrum*. (Pf. III, 1b, 61.)

Family 77. **Elatinaceae**. Small marsh herbs or undershrubs, with small, opposite or whorled leaves; inflorescence axillary; petals imbricated; stamens 4-10. *Elatine*. (Pf. III, 6, 277.)

Family 78. **Frankeniaceae**. Herbs and undershrubs with opposite leaves; petals 4-5, long-stalked; ovules many, on 2-4 parietal placentae. *Frankenia*. (Pf. III, 6, 283.)

Family 79. **Tamaricaceae**. Shrubs and herbs with minute, alternate, deciduous leaves; petals 5; ovules many on central or parietal placentae. *Tamarix*. (Pf. III, 6, 289.)

Family 80. **Fouquieriaceae**. Shrubs with small thorn-like leaves, and paniceled tubular flowers. *Fouquieria*. (Pf. III, 6, 298.)

Family 81. **Salicaceae**. Shrubs and trees with alternate leaves; perianth 0; ovules many on 2-4 parietal placentae. Here regarded as reduced, dioecious, apetalous, *Tamricaccac*. *Salix*, *Populus*. (Pf. III, 1, 29.)

Family 82. **Portulacaceae**. Herbs, or somewhat woody plants, usually somewhat succulent; sepals usually 2; petals 4-5; seeds many. *Claytonia*, *Portulaca*. (Pf. III, 1b, 51.)

Family 83. **Basellaceae**. Herbaceous, or shrubby plants, with mostly alternate leaves; calyx pentamerous; corolla none; stamens 5; ovary 1-celled, with one ovule. *Basella*, *Boussingaultia*. (Pf. III, 1a, 124.)

Family 84. **Aizoaceae**. Herbaceous or shrubby plants with mostly opposite or verticillate leaves; calyx tetramerous or pentamerous; corolla often wanting; ovary 3- to 5-celled with nu-

merous ovules in each cell. *Mollugo*, *Sesuvium*, *Mesembriaanthemum*. (Pf. III, 1b, 33.)

Family 85. **Podostemonaceae**. Small aquatic, sometimes thallose, plants; flowers perfect or diclinous; perianth 0; pistil 1- to 3-celled; ovules many; endosperm 0. *Podostemon*. (Pf. III, 2a, 1.)

Family 86. **Hydrostachydaceae**. Large tuber-forming Madagascar plants, with naked, dioecious flowers, and numerous ovules. *Hydrostachys*. (Pf. III, 2a, 22.)

Family 87. **Phytolaccaceae**. Herbs, shrubs, and trees with usually alternate leaves; petals 0 (or 4-5); carpels several, distinct or nearly so, 1-ovuled. *Phytolacca*. (Pf. III, 1b, 1.)

Family 88. **Nyctaginaceae**. Herbs and shrubs with opposite leaves; petals 0; sepals petaloid; ovule 1, erect. *Mirabilis*, *Bougainvillea*, *Allionia*. (Pf. III, 1b, 14.)

Family 89. **Cynocrambaceae**. Annual, succulent herbs, with petioled leaves, opposite below, alternate above; flower monoecious, apetalous, small, axillary. *Cynocrambe*. (Pf. III, 1a, 121.)

Family 90. **Amaranthaceae**. Herbs, shrubs (and trees), with opposite leaves; petals 0; ovules 1 or more, basal, campylotropous. *Celosia*, *Amaranthus*, *Froelichia*. (Pf. III, 1a, 91.)

Family 91. **Chenopodiaceae**. Herbs, shrubs (and trees) with mostly alternate leaves; petals 0; ovule 1, basal, campylotropous. *Beta*, *Chenopodium*, *Spinacia*, *Atriplex*, *Sarcobatus*, *Salsola*. (Pf. III, 1a, 36.)

Family 92. **Polygonaceae**. Herbs, shrubs, and trees with alternate leaves; petals 0; ovule 1, erect, orthotropous. *Eriogonum*, *Rumex*, *Rheum*, *Polygonum*, *Fagopyrum*, *Coccoloba*. (Pf. III, 1a, 1.)

Family 93. **Batidaceae**. Shrubs with opposite leaves; petals 0; ovary 4-celled; ovule solitary; erect. Very doubtfully placed here. *Batis*. (Pf. III, 1a, 118.)

Order GERANIALES. Receptacle usually with an annular or glandular disk; pistil of several carpels; ovules 1 to 2 (or many), mostly pendulous.

Family 94. **Geraniaceae**. Herbs, shrubs, and trees, with opposite or alternate (compound or simple) leaves; torus clon-

gated; pistil lobed, 3- to 5-celled; endosperm sparse or o. *Geranium*, *Pelargonium*, *Erodium*. (Pf. III, 4, 1.)

Family 95. **Oxalidaceae**. Herbs, rarely shrubs, the juice sour; leaves mostly 3-foliolate; flowers pentamerous. *Oxalis*. (Pf. III, 4, 15.)

Family 96. **Tropaeolaceae**. Succulent, prostrate or climbing herbs, with alternate, peltate leaves, and irregular long-peduncled, spurred flowers; stamens 8; ovary tricarpeillary. *Tropaeolum*. (Pf. III, 4, 23.)

Family 97. **Balsaminaceae**. Succulent herbs, mostly erect, with alternate leaves, and irregular, spurred axillary flowers; stamens 5; ovary pentacarpellary. *Impatiens*. (Pf. III, 5, 383.)

Family 98. **Limnanthaceae**. Succulent marsh herbs, with alternate, pinnate leaves; flowers pentamerous; stamens 10; carpels 5. *Limnanthes*. (Pf. III, 5, 136.)

Family 99. **Linaceae**. Herbs and shrubs, with alternate simple leaves; pistil 3- to 5-celled; endosperm fleshy or o. *Linum*. (Pf. III, 4, 27.)

Family 100. **Humiriaceae**. Trees with alternate simple leaves; pistil 5- to 7-celled; endosperm copious. *Humiria*, *Saccoglottis*. (Pf. III, 4, 35.)

Family 101. **Erythroxylaceae**. Shrubs and trees, with mostly alternate, simple leaves; flowers pentamerous; stamens 10; ovary 2- to 3-carpellary. *Erythroxylon*. (Pf. III, 4, 37.)

Family 102. **Zygophyllaceae**. Herbs and shrubs with usually opposite, compound leaves; pistil lobed, 4- to 5-celled; endosperm copious or o. *Zygophyllum*, *Guaiacum*, *Larrea*. (Pf. III, 4, 74.)

Family 103. **Cneoraceae**. Shrubs with alternate entire leaves, trimerous or tetramerous flowers; pistil 3- or 4-celled, each cell with one ovule. *Cneorum*. (Pf. III, 4, 93.)

Family 104. **Rutaceae**. Herbs, shrubs, and trees with glandular-dotted, opposite, simple, or compound leaves; pistil lobed, 4- to 5-celled; endosperm fleshy or o. *Xanthoxylum*, *Ruta*, *Dictamnus*, *Ptelea*, *Limonia*, *Citrus*. (Pf. III, 4, 95.)

Family 105. **Simarubaceae**. Trees and shrubs with generally alternate, non-glandular, simple, or compound leaves; pistil lobed,

1- to 5-celled; endosperm fleshy or o. *Simaruba*, *Quassia*, *Hoicantha*, *Ailanthus*. (Pf. III, 4, 202.)

Family 106. **Burseraceae**. Balsamic trees and shrubs with alternate compound leaves; pistil 2- to 5-celled; endosperm o. *Protium*, *Canarium*, *Bursera*. (Pf. III, 4, 231.)

Family 107. **Meliaceae**. Trees and shrubs with alternate compound leaves; pistil 3- to 5-celled; endosperm present or o. *Swietenia*, *Melia*. (Pf. III, 4, 258.)

Family 108. **Malpighiaceae**. Trees and shrubs with usually opposite, simple or lobed leaves; pistil tricarpeal; endosperm o. *Stigmatophyllon*, *Malpighia*, *Byrsonima*. (Pf. III, 4, 41.)

Family 109. **Trigoniaceae**. Trees and shrubs with opposite simple leaves, and irregular flowers; pistil tricarpeal. *Trigonina*. (Pf. III, 4, 309.)

Family 110. **Vochysiaceae**. Shrubs and trees with opposite or whorled leaves; sepals 5; petals 1, 3, or 5; stamens several, usually but one fertile. *Vochysia*, *Qualca*. (Pf. III, 4, 312.)

Family 111. **Tremandraceae**. Small shrubs with alternate, opposite, or whorled leaves; sepals and petals 3, 4, or 5 each; stamens twice as many. *Tremandra*, *Tetratheca*. (Pf. III, 4, 320.)

Family 112. **Polygalaceae**. Herbs, shrubs, and trees with alternate leaves; sepals 5; petals 3-5; stamens usually 8. *Polygala*, *Xanthophyllum*. (Pf. III, 4, 323.)

Family 113. **Dichapetalaceae**. Trees and shrubs with alternate simple leaves; pistil 2- to 3-celled; endosperm o. *Dichapetalum*, *Tapura*. (Pf. III, 4, 345.)

Family 114. **Euphorbiaceae**. Herbs, shrubs, and trees, mostly with a milky juice and alternate or opposite leaves; flowers declinous, with a perianth of 1 or 2 whorls, or wanting; stamens 2-celled, free or united; pistil usually 3-celled; endosperm copious. *Euphorbia*, *Pedilanthus*, *Phyllanthus*, *Croton*, *Mallotus*, *Acalypha*, *Ricinus*, *Jatropha*, *Manihot*, *Stillingia*. (Pf. III, 5, 1.)

Family 115. **Callitrichaceae**. Floating herbs with opposite sessile leaves; flowers sessile in the leaf-axils; perianth none; stamens 1 or 2; ovary 2-celled. *Callitriche*. (Pf. III, 5, 120.)

Order GUTTIFERALES. Pistil mostly of 2 or more carpels, 2-celled, with axile placentae; stamens usually indefinite; endosperm usually wanting.

Family 116. **Dilleniaceae.** Petals present, in one whorl; sepals persistent; mostly shrubs and trees with alternate leaves. *Dillenia*, *Actinidia*. (Pf. III, 6, 100.)

Family 117. **Eucryphiaceae.** Evergreen trees of the southern hemisphere, with opposite leaves; flowers large, tetramerous; stamens many; pistil many-celled. *Eucryphia*. (Pf. III, 6, 129.)

Family 118. **Ochnaceae.** Shrubs and trees with alternate, coriaceous, simple leaves; pistil lobed, 1- to 10-celled; endosperm fleshy or o. *Ochna*. (Pf. III, 6, 131.)

Family 119. **Caryocaraceae.** Tropical trees and shrubs, with alternate trifoliate leaves, large showy flowers, and many long stamens. *Caryocar*. (Pf. III, 6, 153.)

Family 120. **Marcgraviaceae.** Tropical trees and shrubs, with alternate, simple leaves; sepals 2-6; petals as many; stamens as many or more; ovary 3-5 celled. *Marcgravia*. (Pf. III, 6, 157.)

Family 121. **Quinaceae.** South American trees and shrubs, with opposite or whorled simple leaves; sepals 4-5; petals 4-5; stamens 15-30. *Quina*. (Pf. III, 6, 165.)

Family 122. **Theaceae.** Trees and shrubs usually with alternate leaves; inflorescence various; petals imbricated. *Thea*, *Sturtia*. (Pf. III, 6, 175.)

Family 123. **Guttiferae.** Trees, shrubs, and herbs, with opposite or whorled, glandular-dotted leaves; inflorescence often trichotomous; petals imbricated or contorted. *Hypericum*, *Mamea*, *Clusia*, *Garcinia*. (Pf. III, 6, 194.)

Family 124. **Dipterocarpaceae.** Trees and shrubs with alternate leaves; inflorescence paniced; petals contorted; fruiting calyx enlarged, and wing-like. *Dipterocarpus*. (Pf. III, 6, 243.)

Family 125. **Cistaceae.** Herbs and shrubs with opposite (or alternate) leaves; sepals 3-5; petals 5; stamens many; pistil 3- to 5-carpellary. *Cistus*, *Helianthemum*, *Hudsonia*. (Pf. III, 6, 299.)

Family 126. **Bixaceae.** Shrubs with alternate leaves; sepals 3 to 7; petals large; stamens indefinite; pistil bicarpellary. *Bixa*. (Pf. III, 6, 307.)

Family 127. **Cochlospermaceae.** Trees and shrubs with alternate lobed or compound leaves; petals large, stamens indefinite; pistil 3- to 5-carpellary. *Cochlospermum*. (Pf. III, 6, 312, and Nach. 251.)

Family 128. **Koeberliniaceae.** Leafless, thorny Texan and Mexican shrubs, with tetramerous flowers; pistil bicarpellary. *Koeberlinia*. (Pf. III, 6, 319.)

Family 129. **Winteranaceae.** Aromatic trees with alternate leaves; sepals 4-5; petals 4-5 (or 0); stamens 20-30; pistil 2- to 5-carpellary. *Winterana*, *Cinnamodendron*. (Pf. III, 6, 314.)

Family 130. **Violaceae.** Herbs and shrubs with alternate (or opposite) leaves; sepals and petals 5, irregular; stamens 5; pistil 3-carpellary. *Rinorea*, *Hybanthus*, *Viola*. (Pf. III, 6, 322.)

Family 131. **Flacourtiaceae.** Trees and shrubs of the tropics, with alternate leaves; sepals 2-15; petals 10-0; stamens indefinite; carpels 2-10. *Pangium*, *Flacourtia*, *Samyda*. (Pf. III, 6a, 1.)

Family 132. **Stachyuraceae.** Asiatic shrubs and trees with alternate leaves; sepals 4; petals 4; stamens 8. *Stachyurus*. (Pf. III, 6, 192.)

Family 133. **Turneraceae.** Herbs and shrubs with alternate leaves; flowers perfect; sepals and petals dissimilar; stamens definite; ovary free; endosperm copious. *Turnera*. (Pf. III, 6a, 57.)

Family 134. **Malesherbiaceae.** South American branching herbs or undershrubs, with pentamerous flowers. *Malesherbia*. (Pf. III, 6a, 65.)

Family 135. **Passifloraceae.** Climbing herbs and shrubs (a few trees) with alternate leaves; flowers perfect; sepals and petals similar, distinct; stamens definite; ovary free; endosperm fleshy. *Adenia*, *Passiflora*. (Pf. III, 6a, 69.)

Family 136. **Achariaceae.** South African herbs and undershrubs, related to the *Passifloraceae*; but with the petals united. *Acharia*. (Pf. III, 6a, 92.)

Family 137. **Caricaceae.** Succulent-stemmed tropical trees, mostly with palmate leaves; flowers pentamerous; fruit a many seeded berry. *Carica*. (Pf. III, 6a, 94.)

Order MALVALES. Pistil usually of 3 to many carpels, with as many cells (sometimes greatly reduced); ovules few; stamens indefinite, monadelphous, branched, or by reduction separate and few; endosperm present or absent.

Family 138. **Tiliaceae**. Trees, shrubs (and herbs) with mostly alternate leaves; flowers mostly perfect, with petals; stamens free, 2-celled; pistil 2- to 10-celled; endosperm present or o. *Corchorus*, *Tilia*, *Grewia*. (Pf. III, 6, 8.)

Family 139. **Gonystylaceae**. East Indian trees with leathery, evergreen leaves, pentamerous flowers, and a berry-like fruit. *Gonystylus*. (Pf. Nach. 231.)

Family 140. **Sterculiaceae**. Trees and shrubs with alternate leaves; flowers perfect or diclinous, with or without petals; stamens mon- or polyadelphous, 2-celled; pistil 4- to many-celled; endosperm present or o. *Theobroma*, *Sterculia*. (Pf. III, 6, 69.)

Family 141. **Malvaceae**. Herbs, shrubs, and trees with alternate leaves; flowers perfect, with petals; stamens monadelphous, 1-celled; pistil 5- to many-celled; endosperm little or o. *Abutilon*, *Althaea*, *Malva*, *Hibiscus*, *Gossypium*. (Pf. III, 6, 30.)

Family 142. **Bombaceae**. Tropical trees with alternate, palmate leaves; sepals and petals present; staminal column 5-8 cleft. *Adansonia*, *Bombax*. (Pf. III, 6, 53.)

Family 143. **Elaeocarpaceae**. Tropical trees and shrubs, with alternate or opposite simple leaves; sepals and petals present; stamens distinct, many; pistil of 2-several carpels. *Elaeocarpus*, *Aristotelia*. (Pf. III, 6, 1.)

Family 144. **Chlaenaceae**. Madagascar trees and shrubs with alternate leaves; inflorescence dichotomous; petals contorted. *Rhodochlaena*, *Leptochlaena*. (Pf. III, 6, 168.)

Family 145. **Scytopetalaceae**. Trees of the southern hemisphere, with alternate leathery leaves; sepals small; petals much larger, valvate; stamens many. *Scytopetalum*. (Pf. Nach. 242.)

Family 146. **Ulmaceae**. Trees and shrubs with alternate, simple leaves, small apetalous flowers, a 1-celled (rarely 2-celled) ovary, which develops into a samara, drupe or nut. *Ulmus*, *Celtis*, *Zelkova*, *Planera*. (Pf. III, 1, 59.)

Family 147. **Moraceae.** Trees, shrubs, and herbs, mostly with a milky juice, and alternate or opposite leaves; flowers apetalous, monoecious or dioecious; ovary 1-celled, 1-ovuled. *Morus*, *Taxylon*, (*Maclura*), *Broussonetia*, *Dorstenia*, *Artocarpus*, *Castilloa*, *Antiaris*, *Ficus*, *Humulus*, *Cannabis*. (Pf. III, 1, 66.)

Family 148. **Urticaceae.** Herbs, shrubs, and trees with alternate or opposite leaves; flowers mostly declinous, without petals; stamens few, 2-celled; pistil monocarpellary, 1-celled, mostly 1-seeded; endosperm none. *Urtica*, *Bochmeria*. (Pf. III, 1, 98.)

Family 149. **Balanopsidaceae.** Australian trees and shrubs with alternate leaves; flowers dioecious, apetalous, the staminate in catkins, the pistillate solitary, producing acorn-like, 2-celled, 2-seeded fruits; seeds endospermous. This family is doubtfully given place here, and it may be that it should be placed near the *Fagaceae*, as is done by Baillon. *Balanops*. (Pf. Nach. 114.)

Subclass HETEROMERAE. Flowers usually gamopetalous; pistil of 3 or more united carpels, its ovary generally superior; ovules usually with but one coat; stamens as many or twice as many as the corolla-lobes. This is a transition group between the Thalamiflorae, and the Bicarpellatae.

Order PRIMULALES. Flowers regular, mostly perfect; stamens mostly opposite to the corolla-lobes; ovary pluricarpellary, mostly 1-celled, with a free central placenta.

Family 150. **Primulaceae.** Herbs with alternate or opposite, sometimes clustered, leaves; stamens opposite the petals; ovules many; fruit a capsule dehiscing longitudinally from the apex, or circumscissily. *Primula*, *Androsace*, *Lysimachia*, *Cyclamen*, *Dodecatheon*. (Pf. IV, 1, 98.)

Family 151. **Plumbaginaceae.** Herbs with alternate or clustered leaves; stamens opposite the petals; ovule 1, basal, anatropous; fruit capsular; dehiscence valvate or irregular. *Plumbago*, *Armeria*. (Pf. IV, 1, 116.)

Family 152. **Myrsinaceae.** Trees and shrubs with alternate (or opposite) leaves; stamens opposite the petals; ovules usually few; fruit a drupe or berry. *Myrsine*, *Ardisia*. (Pf. IV, 1, 84.)

Family 153. **Theophrastaceae**. Tropical trees and shrubs closely related to the preceding family, and usually included in it. *Theophrasta*, *Jacquinia*. (Pf. IV, 1, 88.)

Family 154. **Plantaginaceae**. Herbs with alternate or clustered leaves; stamens alternate with the petals; ovary mostly 2-celled; ovules many; placenta axile; fruit a capsule dehiscent circumscissily. *Plantago*. (Pf. IV, 3b, 363.)

Order ERICALES. Flowers regular, perfect; stamens alternate with the corolla-lobes; cells of the ovary, or placentae 2 to many; seeds minute.

Family 155. **Ericaceae**. Shrubs and small trees with mostly evergreen leaves; ovary typically superior, 2- to 10-celled; anthers usually dehiscent by an apical pore. *Rhododendron*, *Kalmia*, *Gaultheria*, *Arctostaphylos*, *Gaylussacia*, *Vaccinium*, *Calluna*, *Erica*. (Pf. IV, 1, 15.)

Family 156. **Epacridaceae**. Shrubs and small trees with mostly alternate evergreen leaves; ovary superior, mostly 2- to 10-celled; fruit capsular or drupaceous; anthers dehiscent by a slit. *Epacris*. (Pf. IV, 1, 66.)

Family 157. **Diapensiaceae**. Low undershrubs, with alternate evergreen leaves; ovary superior, 3-celled; fruit a capsule; anthers dehiscent by a slit. *Diapensia*, *Shortia*. (Pf. IV, 1, 80.)

Family 158. **Clethraceae**. Shrubs and trees of warm climates, with alternate deciduous leaves; stamens 10; pistil tricarpeled. *Clethra*. (Pf. IV, 1, 1.)

Family 159. **Pirolaceae**. Low evergreen, or chlorophyllous herbs, with pentamerous or tetramerous (rarely hexamerous) flowers; stamens twice as many as the petals; ovary 4- to 6-celled. *Pirola*, *Chimaphila*, *Monotropa*. (Pf. IV, 1, 3.)

Family 160. **Lennoaceae**. Parasitic, leafless herbs; ovary superior, 10- to 14-carpellary, 20- to 28-celled; ovules solitary; anthers dehiscent by a slit. *Lennoa*. (Pf. IV, 1, 12.)

Order EBENALES. Flowers regular, perfect, or diclinous; stamens opposite to the corolla-lobes; ovary 2- to many-celled; seeds mostly solitary or few, usually large.

Family 161. **Sapotaceae**. Tropical trees and shrubs with mostly alternate leaves; flowers mostly perfect; stamens at-

tached to the corolla; ovary superior. *Achras*, *Sideroxylon*, *Chrysophyllum*, *Minusops*. (Pf. IV, 1, 126.)

Family 162. **Ebenaceae**. Tropical and subtropical trees and shrubs, with very hard wood, and mostly alternate leaves; flowers mostly dioecious; stamens usually free from the corolla; ovary superior. *Diospyros*, *Maba*. (Pf. IV, 1, 153.)

Family 163. **Symplocaceae**. Tropical and subtropical trees and shrubs, with mostly perfect flowers; stamens many. *Symplocos*. (Pf. IV, 1, 165.)

Family 164. **Styracaceae**. Trees and shrubs with alternate leaves; flowers mostly perfect; stamens attached to the corolla; ovary usually inferior. *Halesia*, *Styrax*. (Pf. IV, 1, 172.)

Subclass BICARPELLATAE. Flowers gamopetalous; pistil usually of two united carpels, its ovary generally superior; stamens as many as the corolla-lobes or less.

Order POLEMONIALES. Corolla regular; stamens alternate with the corolla-lobes, and of the same number; leaves mostly alternate.

Family 165. **Polemoniaceae**. Herbs (and shrubs) with alternate or opposite leaves; corolla-lobes contorted; ovary tricarpellary, 3-celled; ovules 2 or more. *Cobaea*, *Phlox*, *Gilia*, *Polemonium*. (Pf. IV, 3a, 40.)

Family 166. **Convolvulaceae**. Herbs, shrubs (and trees) with alternate leaves; corolla-limb more or less plicate (rarely imbricated); ovary 2- (3- to 5-) celled; ovules few. *Evolvulus*, *Quamoclit*, *Ipomoea*, *Convolvulus*, *Cuscuta* (parasitic). (Pf. IV, 3a, 1.)

Family 167. **Hydrophyllaceae**. Herbs with radical or alternate (rarely opposite) leaves; corolla-lobes imbricated (or contorted); ovary 1- or incompletely 2-celled; ovules 2 or more. *Hydrophyllum*, *Phacelia*, *Nama*. (Pf. IV, 3a, 54.)

Family 168. **Borraginaceae**. Herbs, shrubs, and trees with alternate leaves; corolla-lobes imbricated (or contorted); ovary bicarpellary, 4-celled, 4-lobed; ovules solitary. *Heliotropium*, *Cynoglossum*, *Orocarya*, *Borrago*, *Myosotis*, *Mertensia*, *Lithospermum*. (Pf. IV, 3a, 71.)

Family 169. **Nolanaceae**. Herbaceous or suffrutescent prostrate plants, with alternate, entire leaves; calyx 5-parted; corolla long funnel-shaped; stamens 5, inserted on the corolla; pistils 5 or united. *Nolana*. (Pf. IV, 3b, 1.)

Family 170. **Solanaceae**. Herbs, shrubs (and trees) with alternate leaves; corolla-limb more or less plicate (rarely imbricated); ovary mostly 2-celled; ovules many. *Lycium*, *Atropa*, *Hyoscyamus*, *Physalis*, *Capsicum*, *Solanum*, *Datura*, *Nicotiana*, *Pectunia*. (Pf. IV, 3b, 4.)

Order GENTIANALES. Corolla regular; stamens alternate with the corolla-lobes, and usually of the same number; leaves opposite (rarely alternate).

Family 171. **Oleaceae**. Shrubs and trees (rarely herbs) with mostly opposite leaves; corolla-lobes valvate or 0; stamens 2 (or 4); ovary 2-celled; ovules 1 to 3. *Syringa*, *Olca*, *Jasminum*, *Fraxinus*. (Pf. IV, 2, 1.)

Family 172. **Salvadoraceae**. Shrubs and trees with opposite undivided leaves; corolla-lobes imbricated; stamens 4; ovary 2-celled; ovules 2. *Salvadora*. (Pf. IV, 2, 17.)

Family 173. **Loganiaceae**. Herbs, shrubs, and trees with mostly opposite simple leaves; corolla-lobes imbricated or contorted; stamens 4 to 5 (or indefinite); ovary 2- to 4-celled; ovules 1 to many. *Gelsemium*, *Logania*, *Spigelia*, *Strychnos*. (Pf. IV, 2, 19.)

Family 174. **Gentianaceae**. Mostly herbs with usually opposite undivided leaves; corolla-lobes contorted, valvate, or induplicate; stamens 4 to 5 (or indefinite); ovary usually 1-celled; ovules many. *Erythraea*, *Gentiana*, *Eustoma*, *Menyanthes*. (Pf. IV, 2, 50.)

Family 175. **Apocynaceae**. Milky-juiced trees, shrubs, and herbs, with opposite, simple leaves; corolla-lobes contorted or valvate; stamens 5 with granular pollen; ovary 2-celled or the carpels separating; ovules many. *Vinca*, *Apocynum*, *Nerium*. (Pf. IV, 2, 109.)

Family 176. **Asclepiadaceae**. Milky-juiced herbs and shrubs, with opposite (or alternate) leaves; corolla-lobes contorted; stamens 5, with agglutinated pollen; ovary of two separated car-

pels; ovules many. *Asclepias*, *Enslenia*, *Ceropegia*, *Stapelia*, *Hoya*. (Pf. IV, 2, 189.)

Order SCROPHULARIALES. Corolla mostly irregular or oblique; stamens fewer than the corolla-lobes, usually 4 or 2; ovules numerous; fruit mostly capsular.

Family 177. **Scrophulariaceae**. Herbs (or shrubs and small trees) with alternate, opposite, or whorled leaves; ovary 2-celled with an axile placenta; seeds with endosperm. *Verbascum*, *Linaria*, *Antirrhinum*, *Maurandia*, *Collinsia*, *Scrophularia*, *Mimulus*, *Veronica*, *Digitalis*, *Gerardia*, *Castilleia*, *Pedicularis*. (Pf. IV, 3b, 39.)

Family 178. **Bignoniaceae**. Trees, shrubs (and herbs) with opposite or whorled leaves; ovary 1- or 2-celled with parietal or axile placentae, seeds numerous without endosperm. *Bignonia*, *Catalpa*, *Tecoma*. (Pf. IV, 3b, 189.)

Family 179. **Pedaliaceae**. Herbs with mostly opposite leaves; ovary 1-, 2-, or 4-celled with axile placentae; seeds 1 to many, with but little endosperm. *Pedaliium*, *Sesamam*. (Pf. IV, 3b, 253.)

Family 180. **Martyniaceae**. Herbs with mostly opposite leaves, and perfect, irregular flowers; ovary with parietal placentae. *Martynia*. (Pf. IV, 3b, 265.)

Family 181. **Orobanchaceae**. Leafless parasitic herbs, ovary 1-celled; placentae parietal; ovules minute, numerous. *Orobanche*, *Thalesia*, *Conopholis*. (Pf. IV, 3b, 123.)

Family 182. **Gesneraceae**. Tropical and subtropical herbs, shrubs (and trees) with usually opposite leaves; ovary 1-celled, with 2 parietal placentae; seeds numerous; endosperm scanty or 0. *Streptocarpus*, *Gesnera*, *Gloxinia*. (Pf. IV, 3b, 133.)

Family 183. **Columelliaceae**. South America trees and shrubs with opposite, evergreen leaves; ovary 2-celled, with an axile placenta. *Columellia*. (Pf. IV, 3b, 186.)

Family 184. **Lentibulariaceae**. Aquatic or marsh herbs with radical or alternate leaves; ovary 1-celled with a globose basilar placenta. *Pinguicula*, *Utricularia*. (Pf. IV, 3b, 108.)

Family 185. **Globulariaceae**. Shrubs and undershrubs or evergreen herbs, with alternate leaves, and a terminal capitate cluster

of small flowers; ovary 1-celled, with a single ovule. *Globularia*. (Pf. IV, 3b, 270.)

Family 186. **Acanthaceae**. Herbs (shrubs and trees) with opposite leaves; ovary 2-celled; placentae axile; seeds 2 to many without endosperm. *Thubergia*, *Ruellia*, *Acanthus*, *Justicia*. (Pf. IV, 3b, 274.)

Order LAMIALES. Corolla mostly irregular or oblique; stamens fewer than the corolla-lobes, usually 4 or 2; ovules mostly solitary; fruit indehiscent.

Family 187. **Myoporaceae**. Shrubs and trees, with usually alternate leaves; flowers axillary. *Myoporum*. (Pf. IV, 3b, 354.)

Family 188. **Phrymaceae**. Erect, perennial herbs, with opposite leaves, and small spicate flowers; calyx and corolla cylindrical, 2-lipped; stamens 4; ovary 1-celled, 1-ovuled. *Phryma*. (Pf. IV, 3b, 361.)

Family 189. **Verbenaceae**. Herbs, shrubs, and trees, with usually opposite leaves; stigma usually undivided. *Verbena*, *Lantana*, *Lippia*, *Tectona*, *Vitex*. (Pf. IV, 3a, 132.)

Family 190. **Labiatae**. Mostly aromatic herbs, shrubs (and trees) with opposite or whorled leaves; stigma usually bifid. *Lavendula*, *Nepeta*, *Stachys*, *Salvia*, *Thymus*, *Mentha*, *Coleus*. (Pf. IV, 3a, 183.)

Subclass CALYCIFLORAE. Calyx usually of united sepals; petals separate, and with the stamens inserted on the calyx or the adherent disk; ovary superior in the lower, and inferior in the higher, families. This subclass originates near the beginning of the Thalamiflorae, and indeed the orders Ranales and Rosales are unquestionably closely related.

Order ROSALES. Flowers usually perfect, regular or irregular; pistils separate or more or less united, sometimes united with the calyx-tube; styles usually distinct.

Family 191. **Rosaceae**. Herbs, shrubs, and trees with mostly alternate leaves; stamens usually indefinite; pistils 1 to many, free (or coalesced and inferior); ovules usually 2, anatropous. *Potentilla*, *Fragaria*, *Spiraea*, *Rosa*, *Pirus*, *Malus*, *Prunus*. (Pf. III, 3, 1.)

Family 192. **Crossosomataceae.** Southwest North American shrubs, with small leaves and a bitter bark; sepals and petals 5 each; stamens 20 or more; carpels 3-5. *Crossosoma*. (Pf. Nach. 185.)

Family 193. **Connaraceae.** Trees and shrubs with alternate compound leaves; stamens definite: pistils 1 to 5, free; ovules 2, ascending, orthotropous. *Connarus*, *Cnestis*. (Pf. III, 3, 61.)

Family 194. **Leguminosae.** Trees, shrubs, and herbs, with alternate, simple, or more commonly, compound leaves, with actinomorphic or zygomorphic flowers; pistil single, monocarpellary, developing into a legume. Usually separated into three subfamilies or families,—*Mimosaccae*, *Caesalpinaceae*, and *Papilionaceae*. One of the largest of plant families (7,000 sp.) distributed throughout all parts of the earth. *Acacia*, *Mimosa*, *Cassia*, *Caesalpinia*, *Gleditsia*, *Gymnocladus*, *Lupinus*, *Medicago*, *Trifolium*, *Robinia*, *Astragalus*, *Arachis*, *Vicia*, *Pisum*, *Phaseolus*. (Pf. III, 3, 70.)

Family 195. **Saxifragaceae.** Herbs, shrubs, and trees with alternate or opposite leaves; stamens mostly definite; pistils usually compound, ovules indefinite. *Sullivantia*, *Saxifraga*, *Heuchera*, *Parnassia*, *Philadelphus*, *Hydrangea*, *Ribes*. (Pf. III, 2a, 41.)

Family 196. **Crassulaceae.** Mostly fleshy herbs, with opposite or alternate leaves; stamens definite; pistils several, free or little united, ovules indefinite. *Sedum*, *Cotyledon*, *Crassula*, *Penthorum*. (Pf. III, 2a, 23.)

Family 197. **Cephalotaceae.** Perennial Australian herbs with a whorl of pipe-shaped radical leaves, and an erect, spicate flowering stem. *Cephalotus*. (Pf. III, 2a, 39.)

Family 198. **Pittosporaceae.** Trees and shrubs of the southern hemisphere, with alternate leaves; sepals, petals, and stamens 5 each. *Pittosporum*, *Marianthus*. (Pf. III, 2a, 106.)

Family 199. **Brunelliaceae.** South American trees, with opposite or whorled leaves; sepals and petals 4 to 5 or 7 each; stamens twice as many; carpels usually 4 to 5, free. *Brunellia*. (Pf. Nach. 182.)

Family 200. **Cunoniaceae**. Shrubs and trees, mostly of the southern hemisphere, with opposite or whorled leaves; sepals and petals 4 to 6 each; stamens twice as many; carpels 2 to 5, united. *Belangeria*, *Cunonia*. (Pf. III, 2a, 94.)

Family 201. **Myrothamnaceae**. Small, rigid, balsamic South African and Madagascar shrubs, with opposite leaves, and dioecious, achlamydeous flowers. *Myrothamnus*. (Pf. III, 2a, 103.)

Family 202. **Bruniaceae**. Heath-like shrubs of the southern hemisphere, with small leaves; stamens definite; pistil mostly 3-celled, inferior or superior; ovules 1 to many, pendulous. *Brunia*. (Pf. III, 2a, 131.)

Family 203. **Hamamelidaceae**. Shrubs and trees with mostly alternate leaves; stamens few or many; pistil bicarpellary, its ovary inferior; ovules solitary or many. *Liquidambar*, *Altingia*, *Hamamelis*. (Pf. III, 2a, 115.)

Family 204. **Casuarinaceae**. Shrubs and trees with striate stems bearing whorls of reduced scale-like leaves; disk 0; petals 0; pistil 1-celled; ovules 2, lateral, half anatropous; endosperm 0. *Casuarina*. (Pf. III, 1, 16.) This family which has puzzled botanists from the first, is doubtfully placed here, on the theory that these plants are leafless relatives of the *Hamamelidaceae*.

Family 205. **Eucommiaceae**. Chinese trees, with alternate leaves, and achlamydeous flowers; stamens 6-10; pistil one-celled, two-seeded. *Eucommia*. (Pf. Nach. 159.)

Family 206. **Platanaceae**. Trees with alternate leaves, and monoecious flowers in globular heads; perianth 0; pistils 1-celled, 1-ovuled; endosperm minute. *Platanus*. (Pf. III, 2a, 137.)

Order MYRTALES. Flowers regular or nearly so, usually perfect; pistil of united carpels, usually inferior; placentae axile or apical (rarely basal); style 1 (rarely several); leaves simple, usually entire.

Family 207. **Lythraceae**. Herbs, shrubs, and trees usually with opposite leaves and 4-angled branches; stamens definite or indefinite; pistil 2- to 6-celled, free; ovules numerous, on axile placentae. *Lythrum*, *Cuphea*, *Lagerstroemia*. (Pf. III, 7, 1.)

Family 208. **Sonneratiaceae**. Tropical trees with opposite leaves; ovary sunken in the calyx-cup, many celled; stamens many. *Sonneratia*. (Pf. III, 7, 16.)

Family 209. **Punicaceae.** Small tropical and subtropical trees with opposite leaves; ovary inferior, 4- to 15-celled, producing a pulpy, many-seeded fruit. *Punica*. (Pf. III, 7, 22.)

Family 210. **Lecythidaceae.** Tropical trees, with alternate opposite or whorled leaves; ovary inferior, 2-6-celled; stamens very many. *Barringtonia*, *Napoleona*, *Lecythis*, *Bertholletia*. (Pf. III, 7, 26.)

Family 211. **Melastomaceae.** Mostly tropical herbs, shrubs, and trees with generally opposite leaves; stamens usually double the number of petals; pistil 2- to many-celled, free or adherent to the calyx-tube; ovules minute, numerous, on axile or parietal placentae. *Melastoma*, *Osbeckia*, *Rhexia*, *Tamonea*. (Pf. III, 7, 130.)

Family 212. **Myrtaceae.** Trees and shrubs with opposite or alternate leaves; stamens indefinite; pistil 2- to many-celled, inferior; ovules 2 to many; placentae basal or axile. *Myrtus*, *Pimenta*, *Eugenia*, *Jambosa*, *Eucalyptus*, *Maldaleuca*. (Pf. III, 7, 57.)

Family 213. **Combretaceae.** Trees and shrubs with opposite or alternate leaves; stamens usually definite; pistil 1-celled, inferior; ovules 2 to 6 or solitary, pendulous. *Terminalia*, *Combretum*, *Laguncularia*. (Pf. III, 7, 106.)

Family 214. **Rhizophoraceae.** Trees and shrubs with mostly opposite leaves; stamens 2 to 4 times the number of petals; pistil 2- to 6-celled, usually inferior; ovules 2, pendulous. *Rhizophora*, *Carallia*. (Pf. III, 7, 42.)

Family 215. **Oenotheraceae.** Herbs (shrubs and trees) with opposite or alternate leaves; stamens 1 to 8, rarely more; pistil usually 4-celled, inferior; ovules 1 to many on axile placentae. *Epilobium*, *Onagra*, *Oenothera*, *Meriolix*, *Gaura*, *Fuchsia*, *Circaea*. (Pf. III, 7, 199.)

Family 216. **Halorrhagidaceae.** Aquatic or terrestrial herbs with mostly alternate leaves; pistil 1- to 4-celled, inferior; ovules solitary, pendulous. *Halorrhagis*, *Myriophyllum*. (Pf. III, 7, 226.)

Family 217. **Hippuridaceae.** Aquatic perennial erect herbs, with whorled leaves, and small, reduced, axillary apetalous flowers. *Hippuris*. (Pf. III, 7, 237.)

Family 218. **Cynomoriaceae.** Parasitic rhizomatous fleshy plants with spicate, small, apetalous flowers. *Cynomorium*. (Pf. III, 1, 250.)

Family 219. **Aristolochiaceae.** Herbaceous or shrubby plants, with alternate leaves; petals absent; stamens 6, rarely more; pistil 4- or 6-celled, inferior; ovules numerous, on axile (or protruding parietal) placentae. *Asarum*, *Aristolochia*. (Pf. III, 1, 264.)

Family 220. **Rafflesiaceae.** Fleshy, parasitic herbs, leafless or nearly so; petals 4 or 0; stamens 8 to many; pistil 1-celled or imperfectly many-celled, inferior; ovules minute, very numerous, on parietal or pendulous, folded placentae. *Rafflesia*, *Cytinus*. (Pf. III, 1, 274.)

Family 221. **Hydnoraceae.** Parasitic, succulent, tropical herbs; perianth single, valvate; stamens numerous, seeds very numerous. *Hydnora*. (Pf. III, 1, 282.)

Order CACTALES. Flowers regular or nearly so, perfect; pistil syncarpous, 1-celled, with parietal placentae, its ovary inferior; style divided at the apex; endosperm present or 0; embryo curved; fleshy-stemmed, mostly leafless, plants.

Family 222. **Cactaceae.** With the characters of the order. *Peireskia*, *Opuntia*, *Cereus*, *Melocactus*, *Cactus*, *Rhipsalis*. (Pf. III, 6a, 156.)

Order LOASALES. Flowers usually regular, perfect or diclinous; pistil syncarpous, 1-celled, its ovary usually inferior; placentae parietal; styles free or connate; leaves ample, entire, lobed, or dissected.

Family 223. **Loasaceae.** Herbs with opposite or alternate leaves; flowers perfect, sepals and petals dissimilar; stamens indefinite; ovary inferior; endosperm fleshy or 0. *Mentzelia*, *Loasa*. (Pf. III, 6a, 100.)

Family 224. **Cucurbitaceae.** Mostly climbing or prostrate herbs and undershrubs, with alternate leaves; flowers diclinous; stamens definite (usually 3); ovary inferior; endosperm 0. *Melothria*, *Momordica*, *Luffa*, *Citrullus*, *Cucumis*, *Lagenaria*, *Cucurbita*. (Pf. IV, 5, 1.)

Family 225. **Begoniaceae.** Mostly herbs with alternate leaves; flowers diclinous; stamens indefinite; ovary inferior, usually 3-angular; endosperm little or 0. *Begonia*. (Pf. III, 6a, 121.)

Family 226. **Datisceae**. Herbs or trees, with alternate leaves; flowers mostly dichinous; stamens 4 to many; ovary inferior, usually gaping at the top; endosperm scanty. *Datisca*. (Pf. III, 6a, 150.)

Family 227. **Ancistrocladaceae**. Climbing plants of tropical Asia, with 5 petals, 5-10 stamens and a 1-celled, many-seeded inferior ovary. *Ancistrocladus*. (Pf. III, 6, 274.)

Order CELASTRALES. Receptacle developing a glandular, annular or turgid disk, which is sometimes adnate to the calyx-tube or the pistil (sometimes the disk is rudimentary or wanting); pistil 1- to many-celled (rarely apocarpous); ovules 1 to 3, pendulous or erect; endosperm present or 0.

Family 228. **Rhamnaceae**. Trees and shrubs, with usually alternate, simple leaves; disk adnate to the calyx; petals present; pistil 2- to 4-celled; ovules 1 or 2, erect; endosperm fleshy. *Zisypus*, *Rhamnus*, *Ceanothus*, *Phyllica*, *Colletia*. (Pf. III, 5, 393.)

Family 229. **Vitaceae**. Climbing shrubs, and trees, with alternate, simple or compound leaves; disk adnate to the calyx; petals coherent, valvate; pistil 2-celled, 2-ovuled (or 3-6-celled, 1-ovuled); endosperm often ruminant. *Vitis*, *Parthenocissus*, *Cissus*. (Pf. III, 5, 427.)

Family 230. **Celastraceae**. Shrubs and trees, with usually alternate, simple leaves; disk fleshy; petals present; pistil 2- to 5-celled; ovules usually 2, erect or pendulous; endosperm fleshy. *Euonymus*, *Celastrus*, *Cassine*. (Pf. III, 5, 189.)

Family 231. **Buxaceae**. Evergreen shrubs and trees, with alternate or opposite leaves, and usually monoecious, small, apetalous flowers; stamens 4; pistil tricarpeal. *Pachysandra*, *Buxus*. (Pf. III, 5, 130.)

Family 232. **Aquifoliaceae**. Trees and shrubs, with alternate or opposite, simple leaves; disk obsolete; pistil 3- to many-celled; ovule 1, pendulous; endosperm fleshy. *Ilex*, *Nemopanthes*. (Pf. III, 5, 183.)

Family 233. **Cyrillaceae**. Evergreen shrubs or small trees, with alternate leaves; sepals 5; petals 5; stamens 10; carpels 2-5, united superior. *Cyrilla*. (Pf. III, 5, 179.)

Family 234. **Pentaphylaceae.** Chinese trees, with alternate, leathery leaves; sepals 5; petals 5; stamens 5; pistil superior, of 5 carpels. *Pentaphylax*. (Pf. Nach, 214.)

Family 235. **Corynocarpaceae.** New Zealand trees, with alternate, fleshy, leathery leaves; sepals 3-5; petals 3-6; stamens 5; pistil superior of 1 or 2 carpels. *Corynocarpus*. (Pf. Nach, 215.)

Family 236. **Hippocrateaceae.** Tropical trailing and climbing woody plants; sepals 5; petals 5; stamens 3 or 2 or 5; pistil of 3 carpels, sessile on the disk. *Hippocratea*, *Salacia*. (Pf. III, 5, 222.)

Family 237. **Stackhousiaceae.** Australian herbs with simple alternate leaves; disk thin, on the base of the calyx; petals present; ovary 2- to 5-celled; ovule 1, erect; endosperm fleshy. *Stackhousia*. (Pf. III, 5, 231.)

Family 238. **Staphyleaceae.** Shrubs and trees, with opposite, compound leaves; sepals 5; petals 5; stamens 5; pistil of 3 carpels, sessile on the disk. *Staphylea*, *Turpinia*. (Pf. III, 5, 258.)

Family 239. **Geissolomataceae.** South African evergreen shrubs, with closely crowded, sessile leaves; sepals 4; petals none; stamens 8; pistil superior, of 4 carpels. *Geissoloma*. (Pf. III, 6a, 205.)

Family 240. **Penaeeaceae.** South African evergreen heath-like shrubs, with small, opposite leaves; disk 0; petals 0; pistil 4-celled; ovules 2, erect; endosperm 0. *Penaea*. (Pf. III, 6a, 208.)

Family 241. **Oliniaceae.** African shrubs and trees, with thick, leathery, opposite leaves; sepals 4-5, large; petals 4-5, very small; stamens 4-5; pistil inferior of 3-5 carpels. *Olinia*. (Pf. III, 6a, 213.)

Family 242. **Thymelaeaceae.** Shrubs, small trees (and herbs), with scattered or opposite, usually coriaceous, simple leaves; disk 0; petals 0; pistil 1-celled; ovule 1, pendulous; endosperm fleshy, copious, sparse, or 0. *Guidia*, *Thymelaea*, *Daphne*, *Dirca*. (Pf. III, 6a, 215.)

Family 243. **Hernandiaceae.** Tropical trees and shrubs, with alternate leaves; flowers monoecious; sepals 4-10; petals none; stamens 3; pistil 1-celled, included in the calyx-tube. *Hernandia*. (Pf. III, 2, 126.)

Family 244. **Elaeagnaceae.** White- or brown-scurfy trees and shrubs, with alternate or opposite, simple leaves; disk lining the perianth-tube; petals 0; pistil 1-celled; ovule 1, ascending; endosperm 0 or scanty. *Elacagnus*, *Lepargyraca*. (Pf. III, 6a, 246.)

Family 245. **Myzodendraceae.** South American parasitic shrubs, with alternate, rather small leaves; flowers dioecious, apetalous; stamens 2-3; pistil 1-celled. *Myzodendron*. (Pf. III, 1, 198.)

Family 246. **Santalaceae.** Parasitic herbs, shrubs, and trees, with alternate or opposite, simple leaves; disk epigynous; petals 0; pistil 1-celled; ovules 2 to 5, pendulous; endosperm present. *Santalum*, *Comandra*, *Thesium*. (Pf. III, 1, 202.)

Family 247. **Opiliaceae.** Small trees and shrubs of tropical climates, with alternate leaves, and perfect flowers; sepals, petals and stamens 4-5 each; pistil superior. *Opilia*. (Pf. Nach. 142.)

Family 248. **Grubbiaceae.** South African shrubs with opposite or whorled leaves, and epigynous, apetalous flowers. *Grubbia*. (Pf. III, 1, 282.)

Family 249. **Olacaceae.** Trees and shrubs, mostly tropical, with usually alternate, simple leaves; disk free or adnate to the calyx; petals present; pistil 1- to 3-celled; ovules 2 to 3, pendulous; endosperm fleshy. *Olax*. (Pf. III, 1, 231.)

Family 250. **Loranthaceae.** Parasitic herbs or shrubs, with opposite or alternate leaves, often reduced to bracts; disk epigynous; petals 0; pistil 1-celled, inferior; ovules 1, erect; endosperm present. *Loranthus*, *Viscum*, *Phoradendron*, *Razoumowskia*. (Pf. III, 1, 156.)

Family 251. **Balanophoraceae.** Parasitic, leafless herbs, all tropical, monoecious or dioecious; disk 0; petals 0; pistil 1-celled, inferior; ovule 1, erect; endosperm present. *Balanophora*. (Pf. III, 1, 243.)

Order SAPINDALES. Disk tumid, adnate to the calyx, lining its tube or rudimentary, or entirely wanting; pistil 1- to several-celled; ovules 1 to 2, erect, ascending, or pendulous; endosperm mostly 0.

Family 252. **Sapindaceae.** Trees and shrubs, mostly tropical, with alternate (or opposite), mostly compound leaves; disk pres-

ent or 0; petals 3 to 5 or 0; pistil 1- to 4-celled; ovules 1 or 2, ascending; endosperm usually 0. *Paullinia*, *Sapindus*, *Talisia*, *Litchi*, *Koelreuteria*, *Dodonaea*. (Pf. III, 5, 277.)

Family 253. **Hippocastanaceae**. Trees and shrubs, with opposite, palmately compound leaves; flowers irregular; sepals 5; petals 5; stamens 8-5; pistil superior, tricarPELLARY. *Asculus*. (Pf. III, 5, 273.)

Family 254. **Aceraceae**. Trees and shrubs, with opposite, simple or compound leaves; sepals mostly 5; petals 5 or none; pistil superior, bicarPELLARY, winged in fruit. *Acer*. (Pf. III, 5, 258.)

Family 255. **Sabiaceae**. Trees and shrubs of the tropics, with alternate, simple or compound leaves; disk small; petals present; pistil 2- to 3-celled; ovules 1 or 2, horizontal or pendulous; endosperm 0. *Sabia*, *Meliosma*. (Pf. III, 5, 367.)

Family 256. **Icacinaceae**. Tropical trees and shrubs, with alternate or opposite leaves; sepals 5-4; petals 5-4; stamens 5-4; pistil superior, of 5 or 3 carpels. *Icacina*. (Pf. III, 5, 233.)

Family 257. **Melanthaceae**. Tropical trees and shrubs, with alternate leaves, and pentamerous, zygomorphic flowers. *Melanthus*. (Pf. III, 5, 374.)

Family 258. **Empetraceae**. Heath-like shrubs, with small leaves; flowers small, mostly dioecious, solitary or in heads; petals present; stamens 2-3, 2- to 3-celled; pistil 2- to many-celled; seeds solitary, endospermous. *Corema*, *Empetrum*. (Pf. III, 5, 123.)

Family 259. **Coriariaceae**. Shrubs with opposite, sessile leaves; 5 sepals; 5 petals; 10 stamens; 5 to 10 carpels, slightly united. *Coriaria*. (Pf. III, 5, 128.)

Family 260. **Anacardiaceae**. Trees and shrubs, mostly tropical, with alternate, usually compound leaves; disk usually annular; petals 3 to 7 or 0; pistil 1- to 5-celled; ovules solitary, pendulous (or erect); endosperm scanty or 0. *Mangifera*, *Anacardium*, *Schinus*, *Cotinus*, *Metopium*, *Rhus*. (Pf. III, 5, 138.)

Family 261. **Juglandaceae**. Trees and shrubs with alternate, compound leaves; disk forming a capsule; pistil 1-celled, inferior; ovule 1, erect, orthotropous; endosperm 0. *Engelhardtia*, *Juglans*, *Hicoria*. (Pf. III, 1, 19.)

Family 263. **Betulaceae.** Trees and shrubs, with alternate, simple leaves, and monoecious or dioecious flowers, which are in aments; petals none; calyx small or none; stamens 2-10; pistil 1-2-celled. *Carpinus*, *Ostrya*, *Corylus*, *Betula*, *Alnus*. (Pf. III, 1, 38.)

Family 264. **Fagaceae.** Trees and shrubs with alternate, simple leaves; disk 0; petals 0; pistil 2- to 6-celled, inferior; ovules 2, erect or pendulous; endosperm 0. *Fagus*, *Castanea*, *Pasania*, *Quercus*. (Pf. III, 1, 47.)

Family 265. **Myricaceae.** Shrubs and trees, with alternate, simple leaves; disk 0; petals 0; pistil free, 1-celled; ovule 1, erect, orthotropous; endosperm 0. *Myrica*. (Pf. III, 1, 26.)

Family 266. **Julianaceae.** Dioecious, tropical trees, with leaves clustered at the ends of the twigs; flowers small, apetalous, dioecious; stamens 4-8; pistil of 3-5 carpels. *Juliana*. (Pf. Nach. 335, and Syllabus III.) This family is given place here very doubtfully.

Family 267. **Proteaceae.** Shrubs, trees (and herbs) of the southern hemisphere, with scattered, simple, usually coriaceous leaves; disk 0; petals 0; pistil 1-celled; ovule 1, erect or pendulous; endosperm little or none. *Protea*, *Leucadendron*, *Grevillea*, *Hakea*, *Banksia*. (Pf. III, 1, 118.) This puzzling family is given place here very doubtfully.

Order UMBELLALES. Flowers, regular, usually perfect; stamens usually definite; pistil syncarpous, 1- to many-celled, its ovary inferior; ovules solitary, pendulous; styles free or united at the base; endosperm copious; embryo usually minute.

Family 268. **Araliaceae.** Trees, shrubs (and herbs), mostly tropical, with alternate leaves; flowers in umbels, heads, or panicles; ovary 2- to 15-celled; fruit a berry with a fleshy or dry exocarp. *Hedera*, *Aralia*, *Panax*. (Pf. III, 8, 1.)

Family 269. **Umbelliferae.** Herbs (shrubs and trees), with alternate leaves; flowers small, mostly umbellate; ovary 2-celled; fruit splitting into two dry indehiscent mericarps. *Hydrocotyle*, *Sanicula*, *Eryngium*, *Coriandrum*, *Conium*, *Apium*, *Cicuta*, *Carum*, *Foeniculum*, *Angelica*, *Ferula*, *Heracleum*, *Daucus*. (Pf. III, 8, 63.)

Family 270. **Cornaceae.** Shrubs and trees (rarely herbs), with usually opposite leaves; flowers umbellate, capitate, or corymbose; ovary 2- to 4-celled; fruit drupaceous. *Garrya*, *Nyssa*, *Cornus*, *Aucuba*. (Pf. III, 8, 250.)

Subclass INFERRAE. Pistil of two or more carpels, united, its ovary inferior; stamens usually as many as the corolla-lobes; mostly attached to the corolla.

Order RUBIALES. Flowers regular or irregular; stamens attached to the corolla; ovary 2- to 8-celled; ovules 2 to many.

Family 271. **Rubiaceae.** Trees, shrubs and herbs, mostly tropical, with opposite or whorled leaves; flowers usually regular, with valvate, contorted, or imbricate corolla-lobes; style simple bifid, or multifid; fruit a capsule, berry, or drupe. *Houstonia*, *Cinchona*, *Bouvardia*, *Cephalanthus*, *Randia*, *Coffea*, *Mitchella*, *Galium*, *Rubia*. (Pf. IV, 4, 1.)

Family 272. **Caprifoliaceae.** Flowers usually irregular, with imbricate corolla-lobes; style usually with a capitate undivided stigma; fruit a berry. *Sambucus*, *Viburnum*, *Linnaea*, *Lonicera*. (Pf. IV, 4, 156.)

Family 273. **Adoxaceae.** Slender, herbs with scaly rootstocks, bearing ternately compound leaves; flowers small, greenish, in heads; stamens 10; fruit drupaceous. *Adoxa*. (Pf. IV, 4, 170.)

Family 274. **Valerianaceae.** Herbs (and shrubs) with opposite leaves; flowers cymose, corymbose, or solitary; anthers free; ovules pendulous. *Valerianella*, *Fedia*, *Valeriana*. (Pf. IV, 4, 172.)

Family 275. **Dipsaceae.** Herbs (and shrubs) with opposite or whorled leaves; flowers in involucrate heads; anthers free; ovule pendulous. *Cephalaria*, *Dipsacus*, *Scabiosa*. (Pf. IV, 4, 182.)

Order CAMPANULALES. Flowers regular or irregular; stamens mostly attached to the corolla, their anthers mostly connate; ovary 1- to several-celled; ovules 1-8.

Family 276. **Campanulaceae.** Mostly milky-juiced herbs (shrubs and small trees), with alternate (or opposite) leaves; flowers regular or irregular; stamens usually 5, free from the style. *Campanula*, *Lobelia*. (Pf. IV, 5, 40.)

Family 277. **Goodeniaceae.** Mostly Australian herbs and shrubs, with alternate (or opposite) leaves; flowers usually irregular; stamens 5, free from the style. *Goodenia*, *Scacvola*, *Brunonia*. (Pf. IV, 5, 70.)

Family 278. **Stylidiaceae.** Australian herbs, with tufted, radical, or scattered and sometimes crowded stem-leaves; flowers usually irregular; stamens 2; connate with the style. *Stylidium*, *Levenhookia*. (Pf. IV, 5, 79.)

Family 279. **Calyceraceae.** South American herbs, with alternate leaves; flowers in involucrate heads; anthers connate; ovule pendulous. *Boopis*, *Calycera*. (Pf. IV, 5, 84.)

Family 280. **Compositae.** Herbs, shrubs (and trees), with opposite or alternate leaves; flowers in involucrate heads; anthers connate; ovule erect. *Helianthus*, *Zinnia*, *Rudbeckia*, *Bidens*, *Inula*, *Antennaria*, *Aster*, *Solidago*, *Eupatorium*, *Vernonia*, *Ambrosia*, *Helenium*, *Anthemis*, *Artemisia*, *Senecio*, *Arnica*, *Calendula*, *Arctotis*, *Cynara*, *Carduus*, *Cnicus*, *Mutisia*, *Cichorium*, *Lactuca*, *Taraxacum*. (Pf. IV, 5, 87.) This immense family, of from 11,000 to 12,000 species, is now quite generally broken up into the families *Compositae* (proper), *Ambrosiaceae*, and *Cichoriaceae*. When treated as a single family the genera (more than 800) are sorted into thirteen tribes. These are of very different values, and need revision and rearrangement, and when this is done they may be raised to the rank of families.

November 26, 1907.

INDEX.

- Abies, 50
 Abietaceae, 50
 Abutilon, 67
 Acacia, 74
 Acalypha, 64
 Acanthaceae, 73
 Acanthus, 73
 Acarospora, 28
 Acarosporaceae, 27
 Acer, 81
 Aceraceae, 81
 Acetabularia, 13
 Acharia, 66
 Achariaceae, 66
 Achlya, 12
 Achras, 70
 Acinetæ, 16
 Acorus, 55
 Acrocarpi, 38
 Acrospermaceae, 30
 Acrosperrnum, 30
 Acrotylaceae, 18
 Acrotylus, 18
 Actinidia, 65
 Actinocyclus, 10
 Actinodiscaceae, 10
 Actinodiscus, 10
 Adansonia, 67
 Adenia, 66
 Adiantum, 44
 Adoxa, 83
 Adoxaceae, 83
 Aecidiaceae, 32
 Aecidium, 32
 Aesculus, 81
 Agaricaceae, 34
 Agaricus, 34
 Agathis, 50
 Agave, 56
 Agrostis, 56
 Ailanthus, 64
 Aizoaceae, 61
 Alaria, 15
 Albugo, 12
 Algae, Brown, 13.
 Algae, Conjugate, 9.
 Algae, Higher, 17.
 Algae, Simple, 6.
 Algae, Slime, 5.
 Algae, Tube, 11.
 Alisma, 53
 Alismales, 52
 Alismataceae, 52
 Allionia, 62
 Allium, 53
 Alnus, 82
 Alsine, 61
 Alsophila, 44
 Althæa, 67
 Alyssum, 60
 Amanita, 34
 Amaranthaceae, 62
 Amaranthus, 62
 Amaryllidaceae, 56
 Amaryllis, 56
 Amblystegium, 43
 Ambrosia, 84
 Ambrosiaceae, 84
 Amerosporium, 36
 Amomum, 57
 Amphipleura, 11
 Amphisphaeria, 22
 Amphisphaeriaceae, 22
 Anabaena, 5
 Anacardiaceae, 81
 Anacardium, 81
 Ananas, 57
 Anauliaceae, 10
 Anaulus, 10
 Ancistrocladaceae, 78
 Ancistrocladus, 78
 Ancylistaceae, 12
 Andreaea, 37
 Andreaeaceae, 37
 Andreaeales, 37
 Andropogon, 56
 Androsace, 68
 Anemone, 58
 Angelica, 82
 Angiopteris, 43
 Ankistrodesmus, 6
 Anomodon, 42
 Anona, 59
 Anonaceae, 59
 Antennaria, 84
 Anthemis, 84
 Anthoceros, 37
 Anthocerotaceae, 37
 Anthocerotales, 37
 Anthophyta, 52
 Anthostoma, 22
 Anthurium, 55
 Antiaris, 68
 Antirrhinum, 72
 Apium, 82
 Apocynaceae, 71
 Apocynum, 71
 Aponogeton, 53
 Aponogetonaceae, 53
 Aquifoliaceae, 78
 Araceae, 55
 Arachis, 74
 Arachnoidiscus, 10
 Arales, 54
 Aralia, 82
 Araliaceae, 82
 Araucaria, 50
 Araucariaceae, 50
 Araucarioxyleae, 48
 Araucarioxylon, 48
 Archidiaceae, 38
 Archidium, 38
 Archiplastideae, 5
 Arctostaphylos, 69
 Arctotis, 84
 Ardisia, 68
 Argemone, 60
 Arisaema, 55
 Aristolochia, 77
 Aristolochiaceae, 77
 Aristotelia, 67
 Arneria, 68
 Arnica, 84
 Artemisia, 84
 Arthonia, 24, 26
 Arthoniaceae, 24
 Arthotelium, 24
 Arthrocladia, 14
 Arthrocladiaceae, 14
 Arthropropyrenia, 23
 Arthrotaxis, 50
 Artisia, 47
 Artocarpus, 68
 Arum, 55
 Asarum, 77
 Aschersonia, 36
 Asclepiadaceae, 71
 Asclepias, 72
 Ascobolaceae, 26
 Ascobolus, 26
 Ascochyta, 35
 Ascocorticaceae, 31
 Ascocorticium, 31

- Ascoidea, 31
 Ascoideaceae, 31
 Ascophyllum, 16
 Ascosporeae, 21
 Aseroc, 33
 Asimina, 59
 Asparagus, 53
 Aspergillaceae, 30
 Aspergillales, 30
 Aspergillus, 30
 Asplenium, 44
 Aster, 84
 Asterina, 21
 Asterolampra, 10
 Astomum, 38
 Astragalus, 74
 Astrotheliaceae, 24
 Astrothelium, 24
 Atriplex, 62
 Atropa, 71
 Aucuba, 83
 Aulocomniaceae, 40
 Aulocomnium, 40
 Auricularia, 35
 Auriculariaceae, 35
 Auriculariales, 35
 Avena, 56
 Azolla, 45

 Bacidia, 27
 Bacteria, 5
 Bacillaria, 11
 Bacillariaceae, 11
 Bacillarioideae, 9
 Bacillus, 5
 Balanophora, 80
 Balanophoraceae, 80
 Balanops, 68
 Balanopsidaceae, 68
 Balsamia, 30
 Balsamiaceae, 30
 Balsaminaceae, 63
 Bambusa, 56
 Bangiaceae, 17
 Bangiales, 17
 Bangioideae, 17
 Banksia, 82
 Barbula, 38
 Barringtonia, 76
 Bartramia, 40
 Bartramiaceae, 40
 Basella, 61
 Basellaceae, 61
 Basidiosporeae, 32
 Batideae, 62

 Batis, 62
 Batrachospermum, 18
 Battarea, 33
 Bazzania, 37
 Beggiatoa, 5
 Begonia, 77
 Begoniaceae, 77
 Belangera, 75
 Bennettitaceae, 48, 52
 Bennettites, 48
 Bennettitineae, 48
 Beomyces, 27
 Berberidaceae, 58
 Berberis, 58
 Bertholletia, 76
 Beta, 62
 Betula, 82
 Betulaceae, 82
 Biatorella, 26, 28
 Bicarpellatae, 70
 Bicuculla, 60
 Biddulphia, 10
 Biddulphiaceae, 10
 Bidens, 84
 Bignonia, 72
 Bignoniaceae, 72
 Bixa, 65
 Bixaceae, 65
 Boehmeria, 68
 Boletus, 34
 Bombaceae, 67
 Bombax, 67
 Bonnemaïsonia, 19
 Bonnemaïsoniaceae, 19
 Boopis, 84
 Borriginaceae, 70
 Borrigo, 70
 Bothrodendraceae, 47
 Bothrodendron, 47
 Botrychium, 43
 Botrydiaceae, 13
 Botrydium, 13
 Botryosphaeria, 23
 Botrytis, 36
 Bougainvillea, 62
 Boussingaultia, 61
 Bouteloua, 56
 Bouvardia, 83
 Bovista, 33
 Brachymerium, 39
 Brassica, 60
 Braunia, 40
 Brentelia, 40
 Bromeliaceae, 57
 Bromus, 56

 Broussonetia, 68
 Brown Algae, 13
 Brunellia, 74
 Brunelliaceae, 74
 Brunia, 75
 Bruniaceae, 75
 Brunonia, 84
 Bryaceae, 39
 Bryales, 38
 Bryophyta, 36
 Bryopsidaceae, 13
 Bryopsidoideae, 13
 Bryopsis, 13
 Bryum, 39
 Buellia, 29
 Buelliaceae, 29
 Bulbochaete, 8
 Bulgaria, 26
 Burmannia, 57
 Burmanniaceae, 57
 Bursa, 60
 Bursera, 64
 Burseraceae, 64
 Butomaceae, 53
 Butomus, 53
 Buxaceae, 78
 Buxbaumia, 40
 Buxbaumiaceae, 40
 Buxus, 78
 Byrsonima, 64

 Cactaceae, 77
 Cactales, 77
 Cactus, 77
 Caesalpinia, 74
 Caesalpinaceae, 74
 Caladium, 55
 Calamariaceae, 46
 Calamariales, 46
 Calamarineae, 45
 Calamodendron, 46
 Calamophyta, 45
 Calamopitys, 47
 Calamostachys, 46
 Calamus, 55
 Calathea, 57
 Calandula, 84
 Caliciaceae, 25
 Caliciales, 25
 Calicium, 25
 Calla, 55
 Callithamnion, 19
 Callitrichaceae, 64
 Callitriche, 64
 Callitris, 51

- Callophyllis, 18
 Calluna, 69
 Calocasia, 55
 Calocera, 34
 Caloplaca, 29
 Caloplacaceae, 29
 Calosphaeria, 23
 Calothrix, 5
 Calycanthaceae, 58
 Calycanthus, 58
 Calycera, 84
 Calyceraceae, 84
 Calyciflorae, 73
 Calymenia, 18
 Calymperaceae, 38
 Calymperes, 38
 Campanula, 83
 Campanulaceae, 83
 Campanulales, 83
 Campopogon, 17
 Campopogonaceae, 17
 Campochaete, 41
 Campothrix, 5
 Campotrichaceae, 5
 Campylodiscus, 11
 Canarium, 64
 Canna, 57
 Cannaceae, 57
 Cannabis, 68
 Capparidaceae, 60
 Capparis, 60
 Caprifoliaceae, 83
 Capsicum, 71
 Carallia, 76
 Carduus, 84
 Carex, 56
 Carica, 66
 Caricaceae, 66
 Carpinus, 82
 Carpomyceteae, 20
 Carpophyceae, 17
 Carum, 82
 Caryocar, 65
 Caryocaraceae, 65
 Caryophyllaceae, 61
 Caryophyllales, 61
 Cassia, 74
 Cassine, 78
 Castalia, 58
 Castanea, 82
 Castilleja, 72
 Castilloa, 68
 Casuarina, 75
 Casuarinaceae, 75
 Catalpa, 72
 Catascopium, 40
 Catharina, 40
 Caulerpa, 13
 Caulerpaceae, 13
 Ceanothus, 78
 Celastraceae, 78
 Celastrales, 78
 Celastrus, 78
 Celidiacae, 24, 26
 Celidium, 26
 Celosia, 62
 Celtis, 67
 Cenangiaceae, 26
 Cenangium, 26
 Centrolepidiaceae, 55
 Centrolepis, 55
 Cephalanthus, 83
 Cephalaria, 83
 Cephaleurus, 24
 Cephalotaceae, 74
 Cephalotaxus, 51
 Cephalotus, 74
 Ceramiaceae, 19
 Ceramium, 19
 Ceratodon, 38
 Ceratomyces, 21
 Ceratophyllaceae, 58
 Ceratophyllum, 58
 Ceratopteris, 44
 Ceratostoma, 22
 Ceratostomataceae, 22
 Ceratostomella, 22
 Ceratozamia, 48
 Cercidiphyllaceae, 58
 Cercidiphyllum, 58
 Cercospora, 36
 Cereus, 77
 Ceropogia, 72
 Chaetangiaceae, 18
 Chaetangium, 18
 Chaetoceraceae, 10
 Chaetoceras, 10
 Chaetomiaceae, 22
 Chaetomium, 22
 Chaetophora, 8
 Chaetophoraceae, 7
 Chaetophorales, 7
 Chaetosphaeria, 22
 Chamaecyparis, 51
 Chamaerops, 55
 Chamaesiphon, 5
 Chamaesiphonaceae, 5
 Champia, 19
 Chara, 20
 Characeae, 20
 Charales, 20
 Charoideae, 17, 20
 Chenopodiaceae, 62
 Chenopodium, 62
 Chimaphila, 69
 Chiodecton, 25
 Chiodectonaceae, 25
 Chlaenaceae, 67
 Chloranthaceae, 59
 Chloranthus, 59
 Chlorochytrium, 6
 Chondrococcus, 20
 Chondrus, 18
 Chorda, 15
 Chordaria, 15
 Chordariaceae, 15
 Choristocarpaceae, 14
 Choristocarpus, 14
 Chroococcaceae, 5
 Chroococcus, 5, 28
 Chroolepus, 23, 24, 25, 26, 27
 Chrysophyllum, 70
 Chrysothricaceae, 27
 Chrysothrix, 27
 Chytridiaceae, 13
 Chytridium, 13
 Cichoriaceae, 84
 Cichorium, 84
 Cicuta, 82
 Cinchona, 83
 Cinnamodendron, 66
 Cinnamomum, 59
 Circaea, 76
 Cissus, 78
 Cistaceae, 65
 Cistus, 65
 Citrullus, 77
 Citrus, 63
 Cladochytriaceae, 12
 Cladochytrium, 12
 Cladonia, 27
 Cladoniaceae, 27
 Cladophora, 12, 27
 Cladophoraceae, 12
 Cladophorales, 12
 Cladosporium, 36
 Cladoxyleae, 47
 Cladoxylon, 47
 Clathraceae, 33
 Clathrus, 33
 Clavaria, 34
 Clavariaceae, 34
 Claviceps, 21
 Claytonia, 61

- Clematis, 58
 Cleome, 60
 Clethra, 69
 Clethraceae, 69
 Climaciaceae, 41
 Climacium, 41
 Closteriaceae, 9
 Closterium, 9
 Clusia, 65
 Cneoraceae, 63
 Cneorum, 63
 Cnestis, 74
 Cnicus, 84
 Cobaea, 70
 Coccocarpia, 28
 Coccogonales, 5
 Cocoloba, 62
 Cocculus, 58
 Cochlospermaceae, 66
 Cochlospermum, 66
 Cocos, 55
 Codiaceae, 12
 Codium, 12
 Coenobiales, 6
 Coenogoniaceae, 27
 Coenogonium, 27
 Coffea, 83
 Coleochaetaceae, 9
 Coleochaetales, 8
 Coleochaete, 9
 Coleosporaceae, 32
 Coleosporium, 32
 Coleus, 73
 Collema, 28
 Collemataceae, 28
 Colletia, 78
 Colletotrichum, 36
 Collinsia, 72
 Columellia, 72
 Columelliaceae, 72
 Comandra, 80
 Combretaceae, 76
 Combretum, 76
 Commelina, 54
 Commelinaceae, 54
 Compositae, 84
 Confervoideae, 7
 Coniferales, 50
 Conifers, 49
 Conium, 82
 Conjugatae, 9
 Conjugate Algae, 9
 Connaraceae, 74
 Connarus, 74
 Conocephalus, 37
 Conopholis, 72
 Convolvulaceae, 70
 Convolvulus, 70
 Coprinus, 34
 Corallina, 20
 Corallinaceae, 20
 Corchorus, 67
 Cordaitaceae, 48
 Cordaites, 47
 Cordaitineae, 48
 Cordierites, 26
 Cordieritidaceae, 26
 Cordyceps, 21
 Corema, 81
 Coriandrum, 82
 Coriaria, 81
 Coriariaceae, 81
 Cornaceae, 83
 Cornus, 83
 Corticium, 34
 Corylus, 82
 Coryneum, 36
 Corynocarpaceae, 79
 Corynocarpus, 79
 Coscinodisaceae, 10
 Coscinodiscus, 10
 Cosmariaceae, 9
 Cosmarium, 9
 Costaria, 15
 Cotinus, 81
 Cotyledon, 74
 Crassula, 74
 Crassulaceae, 74
 Crinum, 56
 Crocus, 56
 Cronartium, 32
 Croomia, 53
 Crossosoma, 74
 Crossosomataceae, 74
 Croton, 64
 Crucibulum, 33
 Cruciferae, 60
 Cryphaea, 41
 Cryphaeaceae, 41
 Cryptonemia, 19
 Cryptonemiales, 19
 Cucumis, 77
 Cunonia, 75
 Cunoniaceae, 75
 Cuphea, 75
 Cupressaceae, 50
 Cupressus, 50
 Curcuma, 57
 Cucurbita, 77
 Cucurbitaceae, 77
 Curcubitaria, 22
 Curcubitariaceae, 22
 Cuscuta, 70
 Cutleria, 16
 Cutleriaceae, 16
 Cutleriales, 15
 Cyanastraceae, 54
 Cyanastrum, 54
 Cyanophyceae, 27
 Cyathea, 44
 Cyatheaceae, 44
 Cyathus, 33
 Cycadaceae, 48
 Cycadineae, 48
 Cycadofilices, 47
 Cycadophyta, 47
 Cycads, 47
 Cycas, 48
 Cyclamen, 68
 Cyclanthaceae, 55
 Cyclanthus, 55
 Cyclosporeae, 16
 Cyliandrocapsa, 8
 Cyliandrocapsaceae, 8
 CyliandrospERMUM, 5
 Cyliandrosporium, 36
 Cymbella, 11
 Cynara, 84
 Cynocrambaceae, 62
 Cynocrambe, 62
 Cynoglossum, 70
 Cynomoriaceae, 77
 Cynomorium, 77
 Cyperaceae, 56
 Cyperus, 56
 Cypheliaceae, 25
 Cyphelium, 25
 Cyripedium, 57
 Cyrilla, 78
 Cyrillaceae, 78
 Cystococcus, 23
 Cystoseira, 16
 Cytinus, 77
 Cyttaria, 26
 Cyttariaceae, 26
 Dacrydium, 51
 Dacryomyces, 34
 Dacryomycetaceae, 34
 Dadoxylon, 48
 Danaea, 43
 Daphne, 79
 Darlingtonia, 60
 Darluca, 35
 Dasya, 19

- Dasycladaceae, 13
 Dasycladales, 13
 Dasyscypha, 26
 Datisca, 78
 Datisceae, 78
 Datura, 71
 Daucus, 82
 Delessaria, 19
 Delessariaceae, 19
 Dematiaceae, 36
 Dematium, 36
 Dendropogon, 57
 Derbesia, 13
 Derbesiaceae, 13
 Dermatea, 26
 Dermatocarpaceae, 23
 Dermatocarpon, 23
 Desmarestia, 15
 Desmarestiaceae, 15
 Desmidiaceae, 9
 Desmidiales, 9
 Desmidium, 9
 Dianthus, 61
 Diapensia, 69
 Diapensiaceae, 69
 Diaporthe, 22
 Diatrypaceae, 23
 Diatrype, 23
 Dicaeoma, 32
 Dichaena, 30
 Dichaenaceae, 30
 Dichapetalaceae, 64
 Dichapetalum, 64
 Dichelyma, 41
 Dicksonia, 44
 Dicotyledonae, 57
 Dicranaceae, 38
 Dicranum, 38
 Dictamnus, 63
 Dictyophora, 33
 Dictyosiphon, 15
 Dictyosiphonaceae, 15
 Dictyota, 16
 Dictyotaceae, 16
 Dictyotales, 16
 Didymella, 22
 Didymodon, 38
 Didymosphaerella, 22
 Digitalis, 72
 Dillenia, 65
 Dilleniaceae, 65
 Dionaea, 60
 Dioon, 48
 Dioscorea, 56
 Dioscoreaceae, 56
 Diospyros, 70
 Diplocladia, 35
 Diploschistaceae, 27
 Diploschistes, 27
 Dipsaceae, 83
 Dipsacus, 83
 Dipterocarpaceae, 65
 Dipterocarpus, 65
 Dirca, 79
 Dirina, 25
 Dirinaceae, 25
 Disceliaceae, 39
 Discelium, 39
 Discella, 36
 Discolichenes, 26
 Ditrichum, 38
 Dodecatheon, 68
 Dodonaea, 81
 Dorstenia, 68
 Dothidea, 21
 Dothideaceae, 21
 Draparnaldia, 8
 Drepanophyllaceae, 39
 Drepanophyllum, 39
 Drosera, 60
 Droseraceae, 60
 Dudresnaya, 19
 Dumontia, 19
 Dumontiaceae, 19
 Durvillaea, 16
 Durvillaeaceae, 16
 Ebenaceae, 70
 Ebenales, 69
 Ectocarpaceae, 14
 Ectocarpales, 14
 Ectocarpus, 14
 Ectolechiaceae, 27
 Elachista, 15
 Elachistaceae, 15
 Elaeagnaceae, 80
 Elaeagnus, 80
 Elaeocarpaceae, 67
 Elaeocarpus, 67
 Elaphomyces, 31
 Elaphomycetaceae, 31
 Elatinaceae, 61
 Elatine, 61
 Eligulatae, 46
 Elodea, 56
 Empetraceae, 81
 Empetrum, 81
 Encalypta, 38
 Encephalartos, 48
 Encoeliaceae, 14
 Endocarpon, 23
 Endogone, 31
 Endomyces, 31
 Endomycetaceae, 31
 Engelhardtia, 81
 Enslenia, 72
 Enteromorpha, 7
 Entodon, 42
 Entodontaceae, 42
 Entomophthora, 13
 Entomophthoraceae, 13
 Entyloina, 32
 Epacridaceae, 69
 Epacris, 69
 Ephebaseae, 28
 Ephebe, 28
 Ephedra, 49
 Ephemeropsis, 42
 Ephemerum, 39
 Epichloe, 21
 Epicoccum, 36
 Epigloea, 23
 Epigloaceae, 23
 Epilobium, 76
 Equisetaceae, 45
 Equisetales, 45
 Equisetaceae, 45
 Equisetites, 45
 Equisetum, 45
 Eremascus, 31
 Erica, 69
 Ericaceae, 69
 Ericales, 69
 Eriocaulon, 54
 Eriocaulonaceae, 54
 Eriogonum, 62
 Erodium, 63
 Erpodiaceae, 40
 Erpodium, 40
 Eryngium, 82
 Erysiphaceae, 21
 Erysiphe, 21
 Erythraea, 71
 Erythronium, 53
 Erythroxyloaceae, 63
 Erythroxylo, 63
 Eschscholtzia, 60
 Eucalamites, 46
 Eucalyptus, 76
 Eucommia, 75
 Eucommiaceae, 75
 Eucryphia, 65
 Eucryphiaceae, 65
 Eugenia, 76
 Euodiaceae, 10

- Euonymus, 78
 Eupatorium, 84
 Euphorbia, 64
 Euphorbiaceae, 64
 Eupodisceae, 10
 Eupodiscales, 10
 Eupodiscus, 10
 Eusporangiatae, 43
 Eustoma, 71
 Evolvulus, 70
 Excipula, 36
 Excipulaceae, 36
 Exidia, 35
 Exoascaceae, 31
 Exoascales, 31
 Exoascus, 31
 Exobasidiaceae, 34
 Exobasidiales, 34
 Exobasidium, 34

 Fabronia, 42
 Fabroniaceae, 42
 Fagaceae, 82
 Fagopyrum, 62
 Fagus, 82
 Fedia, 83
 Ferns, 43
 Ferula, 82
 Ficus, 68
 Filicales, 44
 Fimbristylis, 56
 Firs, Joint, 49
 Fissidens, 38
 Fissidentaceae, 38
 Flacourtia, 66
 Flacourtiaceae, 66
 Flagellaria, 54
 Flagellariaceae, 54
 Florideae, 17
 Flowering Plants, 52
 Foeniculum, 82
 Fomes, 34
 Fontinalaceae, 40
 Fontinalis, 41
 Forsstroemia, 41
 Fossombronina, 37
 Fouquieriaceae, 61
 Fouquieria, 61
 Fragaria, 73
 Fragilaria, 11
 Fragilariaceae, 11
 Frankenia, 61
 Frankeniaceae, 61
 Fraxinus, 71
 Freesia, 56

 Froelichia, 62
 Frullania, 37
 Fucaceae, 16
 Fucales, 16
 Fuchsia, 76
 Fucus, 16
 Fumaria, 60
 Funaria, 39
 Funariaceae, 39
 Fungi, Higher, 20
 Fungi Imperfecti, 35
 Fusarium, 36
 Fusicladium, 36

 Galium, 83
 Garcinia, 65
 Garrya, 83
 Gaultheria, 69
 Gaura, 76
 Gaylussacia, 69
 Geaster, 33
 Geissoloma, 79
 Geissolomataceae, 79
 Gelidiaceae, 18
 Gelidium, 18
 Gelsemium, 71
 Genicularia, 9
 Gentiana, 71
 Gentianaceae, 71
 Gentianales, 71
 Geoglossaceae, 29
 Geoglossum, 29
 Georgia, 40
 Georgiaceae, 40
 Geraniaceae, 62
 Geraniales, 62
 Geranium, 63
 Gerardia, 72
 Gesnera, 72
 Gesneraceae, 72
 Gigartina, 18
 Gigartinaceae, 18
 Gigartinales, 18
 Gilia, 70
 Ginkgo, 49
 Ginkgoaceae, 49
 Ginkgoineae, 48
 Girgensohnia, 41
 Gladiolus, 56
 Glaucocystaceae, 6
 Glaucocystales, 6
 Glaucocystis, 6
 Gleditsia, 74
 Gleichenia, 44
 Gleicheniaceae, 44

 Globularia, 73
 Globulariaceae, 72
 Gloeocapsa, 5, 27, 28
 Gloeosporium, 36
 Gloiopeltis, 19
 Gloiosiphon, 19
 Gloiosiphoniaceae, 19
 Gloxina, 72
 Gnetaceae, 49
 Gnetales, 49
 Gnetineae, 49
 Gnetum, 49
 Gnidia, 79
 Gnomonia, 22
 Gnomoniaceae, 22
 Gomortega, 59
 Gomortegaceae, 59
 Gonatonema, 9
 Gonium, 6
 Gonystylus, 67
 Gonystylaceae, 67
 Goodenia, 84
 Gnomoniaceae, 84
 Gossypium, 67
 Gracilaria, 19
 Graminales, 55
 Gramineae, 56
 Grammatophora, 11
 Graphidaceae, 25
 Graphidales, 24
 Graphina, 25
 Graphis, 25
 Graphium, 36
 Grateloupia, 19
 Grateloupiaceae, 19
 Grevillea, 82
 Grewia, 67
 Grimmia, 38
 Grimmiaceae, 38
 Grimmaldia, 37
 Grinnellia, 19
 Grubbia, 80
 Grubbiaceae, 80
 Guaiacum, 63
 Guepinia, 34
 Guignardia, 22
 Guttiferae, 65
 Guttiferales, 64
 Gyalecta, 27
 Gyalectaceae, 27
 Gymnoascaceae, 30
 Gymnoascus, 30
 Gymnocladus, 74
 Gymnocratae, 15
 Gyrophora, 27

- Gyrophoraceae, 27
 Haemodoraceae, 56
 Haemodorum, 56
 Hakea, 82
 Halesia, 70
 Halicystis, 13
 Halidrys, 16
 Halimeda, 12
 Halopeltis, 14
 Halorrhagidaceae, 76
 Halorrhagis, 76
 Halothrix, 15
 Halymenia, 19
 Hamamelidaceae, 75
 Hamamelis, 75
 Haplospiphon, 6
 Hedera, 82
 Hedwigia, 40
 Hedwigiaceae, 40
 Helenium, 84
 Helianthemum, 65
 Helianthus, 84
 Heliotropium, 70
 Helminthocladiaceae, 18
 Helminthosporium, 36
 Helotiaceae, 26
 Helotium, 26
 Helvella, 29
 Helvellaceae, 29
 Helvellales, 29
 Hemiascales, 31
 Hemidiscus, 10
 Hendersonia, 22
 Hepaticae, 36
 Heppia, 28
 Heppiaceae, 28
 Heracleum, 82
 Hernandia, 79
 Hernandiaceae, 79
 Herposteiraceae, 8
 Herposteirion, 8
 Heteranthera, 53
 Heteromerae, 68
 Heuchera, 74
 Hibiscus, 67
 Hicoria, 81
 Higher Algae, 17
 Higher Fungi, 20
 Himanthalia, 16
 Himanthaliaceae, 16
 Hippocastanaceae, 81
 Hippocratea, 79
 Hippocrateaceae, 79
 Hippuridaceae, 76
 Hippuris, 76
 Holacantha, 64
 Holoplastideae, 6
 Hookeria, 42
 Hookeriaceae, 42
 Hormogonales, 5
 Horsetails, 45
 Houstonia, 83
 Hoya, 72
 Hudsonia, 65
 Humiria, 63
 Humiriaceae, 63
 Humulus, 68
 Huttonia, 46
 Hyaloria, 35
 Hyaloriaceae, 35
 Hyalotheca, 9
 Hybanthus, 66
 Hydnaceae, 34
 Hydnora, 77
 Hydnoraceae, 77
 Hydnum, 34
 Hydrales, 56
 Hydrangea, 74
 Hydrocharis, 56
 Hydrocharitaceae, 56
 Hydrocotyle, 82
 Hydrodictyaceae, 6
 Hydrodictyon, 6
 Hydrogera, 12
 Hydrophyllaceae, 70
 Hydrophyllum, 70
 Hydropteridales, 44
 Hydrostachys, 62
 Hydrostachydaceae, 62
 Hymenophyllaceae, 44
 Hymenophyllum, 44
 Hymenogaster, 32
 Hymenogastraceae, 32
 Hymenogastres, 32
 Hymenomycetales, 33
 Hyoscyamus, 71
 Hypericum, 65
 Hyphomycetales, 36
 Hypnaceae, 43
 Hypnea, 19
 Hypnodendraceae, 42
 Hypnodendron, 42
 Hypnum, 43
 Hypochnaceae, 34
 Hypochnus, 34
 Hypocreaceae, 21
 Hypoderma, 29
 Hypodermataceae, 29
 Hypopterygiaceae, 42
 Hypopterygium, 42
 Hypoxis, 56
 Hypoxylon, 23
 Hysterangium, 32
 Hysteriaceae, 30
 Hysteriales, 29
 Hysterium, 30
 Hysterographium, 30
 Icacina, 81
 Icacinaceae, 81
 Ilex, 78
 Illecebrum, 61
 Impatiens, 63
 Inferae, 83
 Inula, 84
 Ipomoea, 70
 Iridaceae, 56
 Iridaea, 18
 Iridales, 56
 Iris, 56
 Irpex, 34
 Isaria, 36
 Isoetaceae, 43
 Isoetales, 43
 Isoetes, 43
 Isogoniceae, 14
 Isthmia, 10
 Ithyphallus, 33
 Ixia, 56
 Jacquinia, 69
 Jambosa, 76
 Jasminum, 71
 Jatropha, 64
 Joint-Firs, 49
 Juncaceae, 54
 Juncus, 54
 Jungermanniaceae, 37
 Jungermanniales, 37
 Juglandaceae, 81
 Juglans, 81
 Juliana, 82
 Julianaceae, 82
 Juniperaceae, 51
 Juniperus, 51
 Justicia, 73
 Kalmia, 69
 Kibara, 59
 Koeberlinia, 66
 Koeberliniaceae, 66
 Koelreuteria, 81
 Labiatae, 73
 Laboulbenia, 21

- Laboulbeniaceae, 21
 Laboulbeniales, 21
 Lachnea, 25
 Lacistema, 60
 Lacistemaceae, 60
 Lactoridaceae, 59
 Lactoris, 59
 Lactuca, 84
 Lagenaria, 77
 Lagenidium, 12
 Lagerstroemia, 75
 Laguncularia, 76
 Lamiales, 73
 Laminaria, 15
 Laminariaceae, 15
 Lamprothamnium, 20
 Lantana, 73
 Lardizabala, 58
 Lardizabalaceae, 58
 Larix, 50
 Larrea, 63
 Lasiosphaeria, 22
 Lauraceae, 59
 Laurus, 59
 Lavandula, 73
 Lecanactidaceae, 26
 Lecanactis, 26
 Lecanora, 28
 Lecanoraceae, 28
 Lecidia, 27
 Lecidiaceae, 27
 Lecidiopsis, 26
 Lecythidaceae, 76
 Lecythis, 76
 Leguminosae, 74
 Leitneria, 59
 Leitneriaceae, 59
 Lejolisia, 19
 Lemanea, 18
 Lemnaceae, 18
 Lembophyllaceae, 41
 Lembophyllum, 41
 Lemna, 55
 Lemnaceae, 55
 Lennoa, 69
 Lennoaceae, 69
 Lentibulariaceae, 72
 Lepargyrea, 80
 Lepidodendraceae, 47
 Lepidodendron, 47
 Lepidophlois, 47
 Lepidophyta, 46
 Lepidophytales, 46
 Lepidozia, 37
 Leptochlaena, 67
 Leptodon, 41
 Leptogium, 28
 Leptolichen, 23
 Leptosporangiatae, 44
 Leptostomataceae, 39
 Leptostomum, 39
 Leptostroma, 36
 Leptostromataceae, 36
 Leptostromella, 36
 Leptothyrium, 36
 Lepyrodon, 41
 Lepyrodonaceae, 41
 Leskea, 42
 Leskeaceae, 42
 Lessonia, 15
 Leucadendron, 82
 Leucobryaceae, 38
 Leucobryum, 38
 Leucodon, 41
 Leucodontaceae, 41
 Leucoloma, 38
 Leuconostoc, 5
 Leucophanes, 38
 Levenhookia, 84
 Liagora, 18
 Libocedrus, 51
 Lichina, 28
 Lichinaceae, 28
 Ligulatae, 46
 Liliaceae, 53
 Liliales, 53
 Lilium, 53
 Limnanthaceae, 63
 Limnanthes, 63
 Limnocharis, 53
 Limonia, 63
 Linaceae, 63
 Linaria, 72
 Linnaea, 83
 Linum, 63
 Lippia, 73
 Liriodendron, 58
 Litchi, 81
 Lithospermum, 70
 Litsea, 59
 Liverworts, 36
 Loasa, 77
 Loasaceae, 77
 Loasales, 77
 Lobaria, 28
 Lobelia, 83
 Logania, 71
 Loganiaceae, 71
 Lonicera, 83
 Lophodermium, 29
 Lophiostoma, 22
 Lophiostomataceae, 22
 Lophocolea, 37
 Lophosia, 37
 Loranthaceae, 80
 Loranthus, 80
 Luffa, 77
 Lunularia, 37
 Lupinus, 74
 Luzula, 54
 Lychnis, 61
 Lychnothamnium, 20
 Lycium, 71
 Lycoperdaceae, 33
 Lycopodales, 33
 Lycoperdon, 33
 Lycopodiaceae, 46
 Lycopodiales, 46
 Lycopodium, 46
 Lycopods, 46
 Lyginopterideae, 47
 Lyginopteris, 47
 Lygodium, 44
 Lyngbya, 5
 Lysigonium, 10
 Lysimachia, 68
 Lythraceae, 75
 Lythrum, 75
 Maba, 70
 Maclura, 68
 Macomitrium, 39
 Macrocystis, 15
 Macropiper, 59
 Macrosporium, 36
 Macrozamia, 48
 Magnolia, 58
 Magnoliaceae, 58
 Malaleuca, 76
 Malesherbia, 66
 Malesherbiaceae, 66
 Mallotus, 64
 Malpighia, 64
 Malpighiaceae, 64
 Malus, 73
 Malva, 67
 Malvaceae, 67
 Malvales, 67
 Mammea, 65
 Mangifera, 81
 Manihot, 64
 Maranta, 57
 Marantaceae, 57
 Marattia, 43
 Marattiaceae, 43

- Marattiales, 43
 Marcgravia, 65
 Marcgraviaceae, 65
 Marchantia, 37
 Marchantiaceae, 37
 Marchantiales, 36
 Marianthus, 74
 Marsilia, 45
 Marsiliaceae, 44
 Martynia, 72
 Martyniaceae, 72
 Massaria, 22
 Massariaceae, 22
 Matonia, 44
 Matoniaceae, 44
 Maurandia, 72
 Mayaca, 54
 Mayaceae, 54
 Medicago, 74
 Medullosa, 47
 Medulloseae, 47
 Meesea, 40
 Meeseaceae, 40
 Megaloxylon, 47
 Melampsora, 32
 Melanconiaceae, 36
 Melanconiales, 36
 Melanconiaceae, 23
 Melanconis, 23
 Melanconium, 36
 Melastoma, 76
 Melastomaceae, 76
 Melia, 64
 Meliaceae, 64
 Melianthaceae, 81
 Melianthus, 81
 Meliola, 30
 Meliosma, 81
 Melobesia, 20
 Melocactus, 77
 Melogramma, 23
 Melogrammataceae, 23
 Melothria, 77
 Menispermaceae, 58
 Menispermum, 58
 Mentha, 73
 Mentzelia, 77
 Menyanthes, 71
 Meridion, 11
 Meridionaceae, 11
 Meriolix, 76
 Merismopedia, 5
 Mertensia, 70
 Mesembrianthemum, 62
 Mesocarpaceae, 9
 Metasphaeria, 22
 Metopium, 81
 Metzgeria, 37
 Metzgeriaceae, 37
 Micrasterias, 9
 Micrococcus, 5
 Microcoleus, 5
 Microsphaera, 21
 Microspora, 7
 Microsporaceae, 7
 Microsporales, 7
 Microthamniaceae, 8
 Microthamnion, 8
 Microthelia, 23
 Microthyriaceae, 21
 Microthyrium, 21
 Mimosa, 74
 Mimosaceae, 74
 Mimulus, 72
 Mimusops, 70
 Mirabilis, 62
 Mitchellia, 83
 Mitrula, 29
 Mittenia, 39
 Mitteniaceae, 39
 Mniaceae, 39
 Mnium, 40
 Mollisia, 26
 Mollisiaceae, 26
 Mollugo, 62
 Momordica, 77
 Monascaceae, 31
 Monascus, 31
 Monilia, 36
 Monimia, 59
 Monimiaceae, 59
 Monoblepharidaceae, 8
 Monoblepharis, 8
 Monocotyledoneae, 52
 Monotropa, 69
 Monstera, 55
 Moraceae, 68
 Morchella, 29
 Moringa, 60
 Moringaceae, 60
 Moriola, 23
 Moriolaceae, 23
 Morus, 68
 Mosses, 37
 Mosswords, 36
 Mougeotia, 9
 Mucedinaceae, 36
 Mucor, 12
 Mucoraceae, 12
 Musa, 57
 Musaceae, 57
 Musci, 37
 Mutinus, 33
 Mutisia, 84
 Mycocalicium, 25
 Mycoporaceae, 24
 Mycoporum, 24
 Mycosphaerella, 22
 Mycosphaerellaceae, 22
 Myoporaceae, 73
 Myoporum, 73
 Myosotis, 70
 Myosurus, 58
 Myrica, 82
 Myricaceae, 82
 Myriodesma, 16
 Myrionema, 15
 Myriophyllum, 76
 Myriotrichia, 14
 Myriotrichiaceae, 14
 Myristica, 59
 Myristicaceae, 59
 Myrothamnaceae, 75
 Myrothamnus, 75
 Myrsinaceae, 68
 Myrsine, 68
 Myrtaceae, 76
 Myrtales, 75
 Myrtus, 76
 Myxophyceae, 5
 Myzodendraceae, 80
 Myzodendron, 80
 Naiadaceae, 53
 Naias, 53
 Nama, 70
 Napoleona, 76
 Narcissus, 56
 Navicula, 11
 Naviculaceae, 11
 Naviculales, 10
 Neckera, 41
 Neckeraceae, 41
 Nectria, 21
 Nectrioidaceae, 36
 Nelumbo, 58
 Nematium, 18
 Nematiales, 18
 Nemastoma, 20
 Nemastomaceae, 19
 Nematoccae, 42
 Nemopanthes, 78
 Nepenthaceae, 60
 Nepenthes, 60
 Nepeta, 73

- Nephrodium, 44
 Nereocystis, 15
 Nerium, 71
 Nicotiana, 71
 Nidularia, 33
 Nidulariaceae, 33
 Nidulariales, 33
 Nigredo, 32
 Nitella, 20
 Nitellaceae, 20
 Nitophyllum, 19
 Nitschkia, 22
 Nolana, 71
 Nolanaceae, 71
 Nostoc, 5, 24, 28
 Nostocaceae, 5
 Notothylas, 37
 Nyctaginaceae, 62
 Nymphaea, 58
 Nymphaeaceae, 58
 Nyssa, 83

 Ochna, 65
 Ochmaceae, 65
 Ocotea, 59
 Octavinia, 32
 Oedipodiaceae, 39
 Oedipodium, 39
 Oedogoniaceae, 8
 Oedogonium, 8
 Oenothera, 76
 Oenotheraceae, 76
 Oidium, 36
 Olacaceae, 80
 Olax, 80
 Olea, 71
 Oleaceae, 71
 Olinia, 79
 Oliniaceae, 79
 Olpidium, 6
 Onagra, 76
 Onygena, 30
 Onygenaceae, 30
 Oospora, 36
 Opegrapha, 25
 Ophioglossaceae, 43
 Ophioglossales, 43
 Ophioglossum, 43
 Opilia, 80
 Opiliaceae, 80
 Opuntia, 77
 Orcellularia, 27
 Orchidaceae, 57
 Orchidales, 57
 Orchis, 57

 Oreocarya, 70
 Oreodoxa, 55
 Orobanchaceae, 72
 Orobanche, 72
 Orthotrichaceae, 39
 Orthotrichum, 39
 Oryza, 56
 Osbeckia, 76
 Oscillatoria, 5
 Oscillatoriaceae, 5
 Osmunda, 44
 Osmundaceae, 44
 Ostropa, 30
 Ostropaceae, 30
 Ostrya, 82
 Ovularia, 36
 Oxalidaceae, 63
 Oxalis, 63

 Pachysandra, 78
 Padinia, 16
 Palmaceae, 55
 Palmales, 55
 Palmella, 23, 24, 25, 27, 28
 Palmellales, 6
 Panax, 82
 Pandanaceae, 54
 Pandanus, 54
 Pandorina, 6
 Pangium, 66
 Panicum, 56
 Pannaria, 28
 Pannariaceae, 28
 Papaver, 60
 Papaveraceae, 60
 Papilionaceae, 74
 Paratheliaceae, 24
 Parathelium, 24
 Parediella, 21
 Parkeriaceae, 44
 Parmelia, 29
 Parmeliaceae, 29
 Parmentaria, 24
 Parnassia, 74
 Paronychia, 61
 Parthenocissus, 78
 Pasania, 82
 Passiflora, 66
 Passifloraceae, 66
 Patellaria, 26
 Patellariaceae, 26
 Paullinia, 81
 Pedaliaceae, 72
 Pedalium, 72

 Pedicellaria, 6
 Pedicularis, 72
 Pedilanthus, 64
 Peireskia, 77
 Pelargonium, 63
 Peltia, 37
 Peltigera, 28
 Peltigeraceae, 28
 Penaea, 79
 Penaeaceae, 79
 Penicillium, 30
 Penicillus, 12
 Penium, 9
 Pentaphragmataceae, 79
 Pentaphragma, 79
 Penthorum, 74
 Perisporiaceae, 21
 Perisporiales, 21
 Perisporium, 21
 Peronospora, 12
 Peronosporaceae, 12
 Persea, 59
 Pertusaria, 28
 Pertusariaceae, 28
 Pestalozzia, 36
 Petunia, 71
 Peyssonellia, 20
 Peziza, 25
 Pezizaceae, 25
 Pezizales, 25
 Phacelia, 70
 Phaceliaceae, 24
 Phacidiales, 24
 Phacidium, 24
 Phaeophyceae, 13
 Phaeosporaeae, 14
 Phalaris, 56
 Phallaceae, 33
 Phallales, 32
 Phascum, 38
 Phaseolus, 74
 Philadelphus, 74
 Philodendron, 55
 Philonotis, 40
 Philydraceae, 54
 Phloespora, 14
 Phlox, 70
 Phoenix, 55
 Phoma, 35
 Phoradendron, 80
 Phragmidium, 32
 Phryma, 73
 Phrymaceae, 73
 Phycopeltis, 25
 Phyllica, 78

- Phyllachora, 21
 Phyllactidium, 24, 27
 Phyllanthus, 64
 Phyllitis, 14
 Phyllocladaceae, 51
 Phyllocladus, 51
 Phylloglossum, 46
 Phyllopsora, 27
 Phyllopsoraceae, 27
 Phylloporina, 24
 Phyllopyreniaceae, 23
 Phyllosiphon, 12
 Phyllosiphonaceae, 12
 Phyllosticta, 35
 Phyllosticta, 35
 Phyllosticta, 35
 Physalis, 71
 Physalospora, 22
 Physcia, 29
 Physciaceae, 29
 Physcomitrium, 39
 Physma, 28
 Phytolacca, 62
 Phytolaccaceae, 62
 Phytophthora, 12
 Picea, 50
 Pilacraceae, 35
 Pilacre, 35
 Pilacrella, 35
 Pilocarpaceae, 26
 Pilocarpon, 26
 Pilotrichaceae, 42
 Pilotrichum, 42
 Pilularia, 45
 Pimenta, 76
 Pinguicula, 72
 Pinoideae, 50
 Pinus, 50
 Piper, 59
 Piperaceae, 59
 Piptocephalis, 12
 Pirola, 69
 Pirolaceae, 69
 Pirus, 73
 Pisolithus, 33
 Pistillaria, 34
 Pisum, 74
 Pithophora, 12
 Pittosporaceae, 74
 Pittosporum, 74
 Plagiochila, 37
 Planera, 67
 Plantaginaceae, 69
 Plantago, 69
 Plants, Flowering, 52
 Platanaceae, 75
 Platanthera, 57
 Platanus, 75
 Platygloea, 35
 Pleospora, 22
 Pleosporaceae, 22
 Pleurocarpi, 40
 Pleurocladia, 14
 Pleurococcaceae, 6
 Pleurococcus, 23, 25,
 27, 28
 Pleuromoiia, 47
 Pleuromoiaceae, 47
 Pleurophascaceae, 41
 Pleurophascum, 41
 Plocanium, 19
 Plowrightia, 21
 Plumbaginaceae, 68
 Plumbago, 68
 Podaxon, 33
 Podocarpaceae, 51
 Podocarpus, 51
 Podophyllum, 58
 Podostemaceae, 62
 Podostemon, 62
 Pogonatum, 40
 Pohlia, 39
 Polemoniaceae, 70
 Polemoniales, 70
 Polemonium, 70
 Polygala, 64
 Polygalaceae, 64
 Polygonaceae, 62
 Polygonum, 62
 Polypodiaceae, 44
 Polypodium, 44
 Polyporaceae, 34
 Polyporus, 34
 Polysiphonia, 19
 Polystictus, 34
 Polytrichaceae, 40
 Polytrichum, 40
 Pontederia, 53
 Pontederiaceae, 53
 Populus, 61
 Porinia, 23
 Porotrichum, 41
 Porphyra, 17
 Portulaca, 61
 Portulacaceae, 61
 Postelsia, 15
 Potamogeton, 53
 Potamogetonaceae, 53
 Potentilla, 73
 Pottia, 38
 Pottiaceae, 38
 Prasiola, 7
 Prasiolaceae, 7
 Primula, 68
 Primulaceae, 68
 Primulales, 68
 Prionodon, 41
 Prionodontaceae, 41
 Propolis, 24
 Protea, 82
 Proteaceae, 82
 Protium, 64
 Protocaliciaceae, 25
 Protococcaceae, 6
 Protococcoideae, 6
 Protococcus, 6, 25, 26,
 27, 28, 29
 Protocalamariaceae, 46
 Protomyces, 31
 Protomycetaceae, 31
 Protopythaceae, 6
 Protopythaeae, 48
 Protopythys, 48
 Protosiphon, 13
 Prunus, 73
 Psalliota, 34
 Psilotaceae, 46
 Psilotum, 46
 Psoroma, 28
 Ptelea, 63
 Pteridium, 44
 Pteridophyta, 43
 Pteridospermeae, 47
 Pterobryella, 41
 Pterogoniaceae, 42
 Pterogonium, 42
 Pterygium, 28
 Pterygophyllum, 42
 Ptilota, 19
 Puccinia, 32
 Punica, 76
 Punicaceae, 76
 Punctaria, 14
 Pyralis, 42
 Pyrenopeziza, 26
 Pyrenopsis, 28
 Pyrenothamnna, 23
 Pyrenothamnniaceae, 23
 Pyrenidiaceae, 24
 Pyrenidium, 24
 Pyrenolichenes, 23
 Pyrenomycetales, 21
 Pyrenopsidaceae, 28
 Pyrenula, 23
 Pyrenulaceae, 23
 Pyronema, 25

- Pyrenomataceae, 25
 Qualea, 64
 Quamoclit, 70
 Quassia, 64
 Quercus, 82
 Quina, 65
 Quinaceae, 65
 Rafflesia, 77
 Rafflesiaceae, 77
 Ralfsia, 14
 Ralfsiaceae, 14
 Ramalina, 29
 Ramularia, 36
 Ranales, 58
 Randia, 83
 Ranunculaceae, 58
 Ranunculus, 58
 Rapatea, 54
 Rapateaceae, 54
 Raphanus, 60
 Razounowskia, 80
 Reseda, 60
 Resedaceae, 60
 Restio, 55
 Restionaceae, 55
 Rhabdonema, 11
 Rhabdonia, 18
 Rhacomitrium, 38
 Rhamnaceae, 78
 Rhamnus, 78
 Rheum, 62
 Rhexia, 76
 Rhipsalis, 77
 Rhizidium, 13
 Rhizina, 29
 Rhizinaceae, 29
 Rhizoclonium, 12
 Rhizogonium, 40
 Rhizomyxa, 12
 Rhizophyllidaceae, 20
 Rhizophyllis, 20
 Rhizophora, 76
 Rhizophoraceae, 76
 Rhizosolenia, 10
 Rhodochaetaceae, 17
 Rhodochaetales, 17
 Rhodochaete, 17
 Rhodochlaena, 67
 Rhododendron, 69
 Rhodomela, 19
 Rhodomelaceae, 19
 Rhodophyllidaceae, 18
 Rhodophyllis, 18
 Rhodymenia, 19
 Rhodymeniaceae, 19
 Rhodymeniales, 18
 Rhodiales, 60
 Rhus, 81
 Rhynchospora, 56
 Rhytisma, 24
 Ribes, 74
 Riccia, 37
 Ricciaceae, 37
 Ricciocarpus, 37
 Ricinus, 64
 Rinorea, 66
 Rivularia, 5, 28
 Rivulariaceae, 5
 Robinia, 74
 Roccella, 25
 Roccellaceae, 25
 Rosa, 73
 Rosaceae, 73
 Rosales, 73
 Rubia, 83
 Rubiaceae, 83
 Rubiales, 83
 Rudbeckia, 84
 Ruellia, 73
 Rumex, 62
 Russula, 34
 Ruta, 63
 Rutaceae, 63
 Rutilaria, 10
 Rutilariaceae, 10
 Sabia, 81
 Sabiaceae, 81
 Saccharomyces, 31
 Saccharomycetaceae, 31
 Saccoglottis, 63
 Sagittaria, 53
 Salacia, 79
 Salicaceae, 61
 Salix, 61
 Salsola, 62
 Salvadora, 71
 Salvadoraceae, 71
 Salvia, 73
 Salvinia, 45
 Salviniaceae, 45
 Sambucus, 83
 Samyda, 66
 Sanguinaria, 60
 Sanicula, 82
 Santalaceae, 80
 Santalum, 80
 Sapindaceae, 80
 Sapindales, 80
 Sapindus, 81
 Sapotaceae, 69
 Saprolegnia, 12
 Saprolegniaceae, 12
 Sarcina, 5
 Sarcobatus, 62
 Sarcographa, 25
 Sarcoscypha, 26
 Sargassaceae, 16
 Sargassum, 16
 Sarracenia, 60
 Sarraceniaceae, 60
 Sarraceniales, 60
 Sassafras, 59
 Sauraceae, 59
 Saururus, 59
 Saxifraga, 74
 Saxifragaceae, 74
 Scabiosa, 83
 Scaevola, 84
 Scapania, 37
 Scenedesmus, 6
 Scheuchzeria, 53
 Scheuchzeriaceae, 53
 Schinus, 81
 Schizaea, 44
 Schizaeaceae, 44
 Schizogoniales, 7
 Schizostegia, 39
 Schizostegiaceae, 39
 Schizymeria, 20
 Scirpus, 56
 Scirpoderma, 33
 Sclerodermataceae, 33
 Sclerodermatales, 33
 Scleroderris, 24
 Sclerotinia, 26
 Scrophularia, 72
 Scrophulariaceae, 72
 Scrophulariales, 72
 Scytonema, 5, 24, 27, 28
 Scytonemataceae, 5
 Scytopetalaceae, 67
 Scytopetalum, 67
 Secotium, 32
 Sedum, 74
 Selaginella, 46
 Selaginellaceae, 46
 Selaginellales, 46
 Sematophyllaceae, 42
 Sematophyllum, 42
 Senecio, 84
 Septoria, 35
 Sequoia, 50

- Sesamum, 72
 Sesuvium, 62
 Shortia, 69
 Sideroxylon, 70
 Sigillaria, 47
 Sigillariaceae, 47
 Silene, 61
 Simaruba, 64
 Simarubaceae, 63
 Simblum, 33
 Simple Algae, 6
 Sinapis, 60
 Siparuna, 59
 Siphonales, 12
 Siphonomycetaceae, 12
 Siphonophyceae, 11
 Sirobasidiaceae, 35
 Sirobasidium, 35
 Sirogonium, 9
 Sirosiphon, 34
 Sisyrinchium, 56
 Slime Algae, 5
 Solanaceae, 71
 Solanum, 71
 Soleniaceae, 10
 Solidago, 84
 Sonneratia, 75
 Sonneratiaceae, 75
 Soranthera, 14
 Sordaria, 22
 Sordariaceae, 22
 Sparganiaceae, 55
 Sparganium, 55
 Spermatochnaceae, 15
 Spermatochnus, 15
 Sphacelaria, 14
 Sphacelariaceae, 14
 Sphacelotheca, 32
 Sphaeriaceae, 22
 Sphaeroidaceae, 35
 Sphaerobolaceae, 33
 Sphaerobolus, 33
 Sphaerococcaceae, 19
 Sphaeronemella, 36
 Sphaerophoraceae, 25
 Sphaerophorus, 25
 Sphaeroplea, 12
 Sphaeropleaceae, 12
 Sphaeropsidales, 35
 Sphaeropsis, 35
 Sphagnaceae, 38
 Sphagnales, 38
 Sphagnum, 38
 Sphenophyllaceae, 45
 Sphenophyllales, 45
 Sphenophyllineae, 45
 Sphenophyllum, 45
 Spigelia, 71
 Spilonema, 28
 Spinacia, 62
 Spiraea, 73
 Spiranthus, 57
 Spiridentaceae, 41
 Spirodela, 55
 Spirogyra, 9
 Spirogyraceae, 9
 Splanchnaceae, 39
 Splanchnidium, 16
 Splanchnum, 39
 Sporochneaceae, 15
 Sporochneus, 15
 Sporopodium, 27
 Sporormia, 22
 Sporotrichum, 36
 Squamariaceae, 20
 Stachys, 73
 Stachyuraceae, 66
 Stachyurus, 66
 Stackhousia, 79
 Stackhousiaceae, 79
 Stapelia, 72
 Staphylea, 79
 Staphyleaceae, 79
 Steloxylon, 47
 Stemona, 53
 Stemonaceae, 53
 Sterculia, 67
 Sterculiaceae, 67
 Stereocaulon, 27
 Stereodon, 42
 Stereodontaceae, 42
 Stereum, 34
 Sterigmatocystis, 36
 Stichococcus, 25
 Sticta, 28
 Stictaceae, 28
 Stictidaceae, 24
 Stictis, 24
 Stigmatophyllum, 64
 Stigonema, 6, 28
 Stigonemataceae, 6
 Stilbaceae, 36
 Stillingia, 64
 Stilophora, 15
 Stilophoraceae, 15
 Streblonema, 14
 Strelitzia, 57
 Streptocarpus, 72
 Striaria, 14
 Striariaceae, 14
 Strickeria, 22
 Strigula, 24
 Strigulaceae, 24
 Strobilophyta, 49
 Struvea, 13
 Strychnos, 71
 Stuartia, 65
 Styliidiaceae, 84
 Styliidium, 84
 Stypocaulon, 14
 Styrcaceae, 70
 Styrax, 70
 Stysanus, 36
 Sullivantia, 74
 Surirella, 11
 Surirellaceae, 11
 Swietenia, 64
 Symplocaceae, 70
 Symplocarpus, 55
 Symplocos, 70
 Synalissa, 28
 Synchytriaceae, 6
 Synchytrium, 6
 Synedra, 11
 Syringa, 71
 Syrrhopodon, 38
 Tabellariaceae, 11
 Tacca, 56
 Taccaceae, 56
 Talisia, 81
 Tamaricaceae, 61
 Tamarix, 61
 Tamonea, 76
 Taphrina, 31
 Tapura, 64
 Taraxacum, 84
 Taxaceae, 51
 Taxales, 51
 Taxodiaceae, 50
 Taxodium, 50
 Taxus, 51
 Tecoma, 72
 Tectona, 73
 Teliosporeae, 31
 Terfezia, 31
 Terfeziaceae, 31
 Terminalia, 76
 Terpsinoe, 10
 Testudinaria, 56
 Tetradontium, 40
 Tetraspora, 6
 Tetrasporae, 16
 Tetratheca, 64
 Thalamiflorae, 57

- Thalesia, 72
 Thea, 65
 Theaceae, 65
 Thelephora, 34
 Thelephoraceae, 34
 Thelidium, 23
 Thelocarpon, 28
 Theloschistaceae, 29
 Theloschistes, 29
 Thelotrema, 27
 Thelotremataceae, 27
 Theobroma, 67
 Theophrasta, 69
 Theophrastaceae, 69
 Thesium, 80
 Thorea, 18
 Thoreaceae, 18
 Thuidium, 42
 Thunbergia, 73
 Thurnia, 54
 Thurniaceae, 54
 Thuya, 51
 Thuyopsidaceae, 51
 Thymelaea, 79
 Thymelaeaceae, 79
 Thymus, 73
 Thyrea, 28
 Tigridia, 56
 Tilia, 67
 Tiliaceae, 67
 Tillandsia, 57
 Tilletia, 32
 Tilletiaceae, 32
 Tilopteridaceae, 16
 Tilopteridales, 16
 Tilopteris, 16
 Timmia, 40
 Timmiaceae, 40
 Tmesipteris, 46
 Tolypella, 20
 Tolypelopsis, 20
 Tolypothrix, 5
 Tomentella, 34
 Toninia, 27
 Torreya, 51
 Tortula, 38
 Torula, 36
 Tovaria, 60
 Tovariaceae, 60
 Toxylon, 68
 Tradescantia, 54
 Tremandra, 64
 Tremandraceae, 64
 Tremella, 35
 Tremellaceae, 35
 Tremellales, 35
 Trentopohlia, 8
 Trentopohliaceae, 8
 Triceratium, 10
 Trichocoma, 30
 Trichocomataceae, 30
 Trichomanes, 44
 Trichosphaeria, 22
 Trichosporium, 36
 Trifolium, 74
 Triglochis, 53
 Trigonia, 64
 Trigoniaceae, 64
 Triticum, 56
 Tritonia, 56
 Triuridaceae, 53
 Triuris, 53
 Trochodendraceae, 58
 Trochodendron, 58
 Tropaeolaceae, 63
 Tropacolum, 63
 Tryblidiaceae, 24
 Tryblidium, 24
 Trypetheliaceae, 24
 Trypethelium, 24
 Tube Algae, 11
 Tuber, 30
 Tuberales, 30
 Tuberculariaceae, 36
 Tuberculina, 36
 Tulasnella, 34
 Tulasnellaceae, 34
 Tulipa, 53
 Tumboa, 49
 Turnera, 66
 Turneraceae, 66
 Turpinia, 79
 Tylophoron, 25
 Tylostoma, 33
 Tylostomataceae, 33
 Typha, 55
 Typhaceae, 55
 Udotea, 12
 Ulmaceae, 67
 Ulmus, 67
 Ulota, 39
 Ulothrix, 7
 Ulotrichaceae, 7, 14
 Ulva, 7
 Ulvaceae, 7
 Ulvales, 7
 Umbellales, 82
 Umbelliferae, 82
 Umbellularia, 59
 Umbilicaria, 27
 Uredinaceae, 32
 Uredinales, 32
 Uredo, 32
 Uromyces, 32
 Uronema, 7
 Uropyxis, 32
 Urtica, 68
 Urticaceae, 68
 Usnea, 29
 Usneaceae, 29
 Ustilaginaceae, 32
 Ustilaginales, 32
 Ustilago, 32
 Utricularia, 72
 Vaccinium, 69
 Valeriana, 83
 Valerianaceae, 83
 Valerianella, 83
 Vallisneria, 56
 Valonia, 13
 Valoniaceae, 13
 Valoniales, 13
 Valsa, 22
 Valsaceae, 22
 Vanilla, 57
 Vaucheria, 12
 Vaucheriaceae, 12
 Vaucherioideae, 12
 Vellozia, 56
 Velloziaceae, 56
 Venturia, 22
 Verbascum, 72
 Verbena, 73
 Verbenaceae, 73
 Vernonia, 84
 Veronica, 72
 Verpa, 29
 Verrucaria, 23
 Verrucariaceae, 23
 Verticillium, 36
 Vibrio, 5
 Viburnum, 83
 Vicia, 74
 Victoria, 58
 Vinca, 71
 Viola, 66
 Violaceae, 66
 Viscum, 80
 Vitaceae, 78
 Vitex, 73
 Vitis, 78
 Vochysia, 64

- Vochysiaceae, 64
Voelkelia, 47
Volvocaceae, 6
Volvox, 6
Webera, 39
Weisia, 38
Winterana, 66
Winteranaceae, 66
Wrangelia, 18
Xanthocapsa, 28
Xanthophyllum, 64
Xanthoxylum, 63
Xyridaceae, 54
Xylaria, 23
Xylariaceae, 23
Xyris, 54
Yucca, 53
Zamia, 48
Zanerdingia, 16
Zannichellia, 53
Zea, 56
Zelkova, 67
Zingiber, 57
Zingiberaceae, 57
Zinnia, 84
Zizyphus, 78
Zonaria, 16
Zostera, 53
Zygnema, 9
Zygnemales, 9
Zygnemataceae, 9
Zygodon, 39
Zygogonium, 9
Zygophyceae, 9
Zygophyllaceae, 63
Zygophyllum, 63
Zythia, 36

Volumes I, II, III, IV, V, and VI of UNIVERSITY STUDIES are each complete in four numbers.

Index and title-page for each volume are published separately.

A list of the papers printed in the first two volumes may be had on application.

Single numbers (excepting vol. II, no. 3) may be had for \$1.00 each.

A few copies of volumes I, II, III, IV, V, VI, and VII, complete in numbers, are still to be had.

All communications regarding purchase or exchange should be addressed to

THE UNIVERSITY OF NEBRASKA LIBRARY

LINCOLN, NEB., U. S. A.

SMITHSONIAN INSTITUTION LIBRARIES

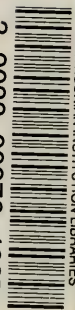

3 9088 00876 4037