

58M

1015

Bulletin of the British Museum (Natural History)

BRITISH MUSEUM
(NATURAL HISTORY)
25 OCT 1984
PRESENTED
GENERAL LIBRARY

Entomology series Vol 48 1984

British Museum (Natural History)
London 1984

Dates of publication of the parts

No 1	26 January 1984
No 2	23 February 1984
No 3	28 June 1984

ISSN 0524-6431

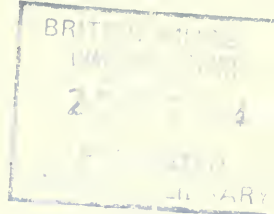

Contents
Entomology Volume 48

No 1	Gelechiid moths of the genus <i>Mirificarma</i> By Linda M. Pitkin	1
No 2	Macronematine caddisflies of the genus <i>Amphipsyche</i> (Trichoptera: Hydropsychidae) By P. C. Barnard	71
No 3	A review of the genera of Indo-Pacific Encyrtidae (Hymenoptera: Chalcidoidea) By John S. Noyes & M. Hayat	131

Bulletin of the British Museum (Natural History)

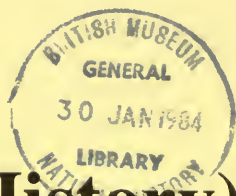

Gelechiid moths of the genus *Mirificarma*

Linda M. Pitkin

Entomology series

Vol 48 No 1

26 January 1984

The *Bulletin of the British Museum (Natural History)*, instituted in 1949, is issued in four scientific series, Botany, Entomology, Geology (incorporating Mineralogy) and Zoology, and an Historical series.

Papers in the *Bulletin* are primarily the results of research carried out on the unique and ever-growing collections of the Museum, both by the scientific staff of the Museum and by specialists from elsewhere who make use of the Museum's resources. Many of the papers are works of reference that will remain indispensable for years to come.

Parts are published at irregular intervals as they become ready, each is complete in itself, available separately, and individually priced. Volumes contain about 300 pages and several volumes may appear within a calendar year. Subscriptions may be placed for one or more of the series on either an Annual or Per Volume basis. Prices vary according to the contents of the individual parts. Orders and enquiries should be sent to:

Publications Sales,
British Museum (Natural History),
Cromwell Road,
London SW7 5BD,
England.

World List abbreviation: *Bull. Br. Mus. nat. Hist.* (Ent.)

© Trustees of the British Museum (Natural History), 1984

The Entomology series is produced under the general editorship of the
Keeper of Entomology: Laurence A. Mound
Assistant Editor: W. Gerald Tremewan

ISBN 0 565 06000 7
ISSN 0524-6431

British Museum (Natural History)
Cromwell Road
London SW7 5BD

Entomology series
Vol 48 No 1 pp 1-70

Issued 26 January 1984

Gelechiid moths of the genus *Mirificarma*

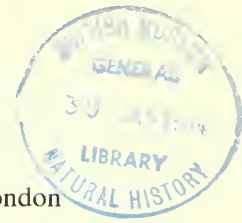

Linda M. Pitkin

Department of Entomology, British Museum (Natural History), Cromwell Road, London SW7 5BD

Contents

Synopsis.....	1
Introduction.....	1
Methods.....	2
Abbreviations of institutions.....	3
Acknowledgements.....	3
Host-plant relationships within <i>Mirificarma</i>	3
The systematic position of <i>Mirificarma</i>	5
Classification of <i>Mirificarma</i> species.....	6
The structure of the filament of the male genitalia.....	12
<i>Mirificarma</i> Gozmány.....	13
Key to the species of <i>Mirificarma</i>	16
Males.....	16
Females.....	17
The <i>montivaga</i> -group.....	18
The <i>maculatella</i> -group.....	19
The <i>interruptella</i> -group.....	29
References.....	45
Index.....	70

Synopsis

The Palaearctic genus *Mirificarma* is revised and three new species are described. Twenty-one species are recognized and four synonyms are newly established; seven new generic combinations are included. Keys to the species, and figures of the external features and genitalia of all the species are given. The systematic position of *Mirificarma* is discussed and a provisional classification of the species based on a cladistic analysis is provided, together with an account of the filament, a unique structure of the male genitalia of *Mirificarma*. Biological data, as far as known, are given for all the species, and the host-plant relationships within the genus are discussed.

Introduction

The genus *Mirificarma* consists of 21 species of Microlepidoptera from Europe and the Mediterranean region, with one species introduced to the U.S.A. The moths are of average size for Gelechiidae, with a wingspan usually between one and two centimetres. They vary in wing pattern; some species have the fore wing with yellowish zig-zag markings, others have spots, a median longitudinal stripe, or are almost uniform in colour. The larvae feed on Leguminosae.

Mirificarma cannot be defined readily on external characters and, since early microlepidopterists relied on such characters, many species have been misplaced in other genera. Hitherto, no comprehensive account of the genus has been given, although a partial revision by Sattler (1960: 41–45) covered aspects of eight species.

The purpose of this study is to describe three new species, to include seven previously misplaced species and to provide a key by which all the species can be identified. In addition, this study examines the host-plant relationships within *Mirificarma*, describes the structure of the filament, a character of the male genitalia unique to the genus, investigates the systematic position of the genus within the Gelechiidae and proposes a classification of the species within *Mirificarma*.

This study aims to resolve the confusion over the interpretation of the filament and its

BRU 90823

associated structures. Moreover, examination of these structures has helped to indicate the relationships of *Mirificarma* within the Gelechiidae.

Photographs of the wings of every species are reproduced but should only be used as a rough guide for identification. The wing patterns of some species are very similar and, in a few cases, considerable variation within species can make identification very difficult. However, there are abundant distinct genitalic differences between *Mirificarma* species and, to enable accurate determination, the key is based mainly on these.

The leguminous host-plants are of particular interest since they provide evidence to corroborate the division of the genus into species-groups. Two species, *flavella* and *eburnella*, feed on plants grown as fodder-crops but neither is recorded as an agricultural pest in Europe. However, *eburnella* has been introduced to the U.S.A. where it has caused severe damage to clover and vetch crops (see p. 28).

Methods

The measurements given at the beginning of each description are the range in fore wing length of the specimens examined, to the nearest half millimetre. Measurements which are far outside the normal range for a species are given in parentheses, in addition to the range for the other specimens examined of the species. The length of the apophysis anterior in the female genitalia was measured from the apex of the apophysis to the level at which it joins the antrum. Since the apophyses anteriores are sometimes of unequal length, the range in length given is derived from the mean of the pair. The number of specimens examined is given in parentheses after this measurement.

Standard methods of genitalia preparation were followed except that where sufficient material was available, the vinculum was separated from the tegumen on one side of the male genitalia and laid out flat beside the tegumen, in order that the complex structures should be more clearly displayed in the photographs. This has also facilitated the examination of the structures. For staining, mercurochrome was used. The terminology of the genitalia follows that of Klots (1956) and Sattler (1979). The descriptions of the sacculus refer to the posterior portion of this which is free from the vinculum.

The specimens examined are deposited in the British Museum (Natural History) unless otherwise stated. Records from Mr E. Jäckh, Bidingen are based on photographs of genitalia preparations only. The data of type-material are given in full and sometimes include information from the original description, additional to that from the specimen label; data from sources other than these are given in square brackets. Data of specimens other than types are abbreviated by omitting collectors' names and dates other than months. For widespread and well-documented species localities are summarized under country, with province or region where appropriate. The spelling of locality names follows *The Times Atlas of the World* (Comprehensive Edn), 1968, as far as possible. The distribution records are based on material examined unless otherwise stated.

Most of the specimens examined in this study bear my determination labels dated '1982' or earlier. Any specimens with subsequent determination labels are not included.

Lectotype designations are made where necessary, in some cases for species which were based on an unspecified number of specimens, even where only one original specimen is currently known. Lectotypes are also designated for species described by Walsingham where he referred to a 'type ♂' and a 'type ♀' but did not specify a single 'type' or holotype. In these cases the specimen selected is that listed first by Walsingham, usually the male. These lectotype designations follow the practice discussed by Sattler (1976: 89).

Some of the photographs of the wings have been reversed.

The botanical nomenclature and classification follow Polhill & Raven (1981); European plant names not included in that work follow Tutin *et alii* (1964–1980).

Abbreviations of institutions

BMNH	British Museum (Natural History), London.
LN	Landessammlungen für Naturkunde, Karlsruhe.
MINGA	Muzeul de Istorie Naturală 'Grigore Antipa', Bucharest.
MNHN	Muséum National d'Histoire Naturelle, Paris.
MNHU	Museum für Naturkunde der Humboldt-Universität, Berlin.
NM	Naturhistorisches Museum, Vienna.
TM	Természettudományi Múzeum, Budapest.
ZM	Zoologisk Museum, Copenhagen.

Acknowledgements

I am most grateful to the following specialists for loan and donation of material, and for helpful information: Mr L. Aarvik, Ås, Norway; Rev. D. Agassiz, Grays, Essex; Mr E. Arenberger, Vienna; Mr K. Burmann, Innsbruck; Dr L. Gozmány, TM; Dr H. J. Hannemann, MNHU; Dr R. W. Hodges, U.S.D.A./National Museum of Natural History, Washington, D.C.; Mr E. Jäckh, Bidingen, West Germany; Mr O. Karsholt, ZM; Dr F. Kasy, NM; Dr J. Klimesch, Linz; Dr J. Langmaid, Portsmouth, Hampshire; Dr E. S. Nielsen, ZM; Dr T. Peet, Guernsey; Dr A. Popescu-Gorj, MINGA; Dr J. Powell, University of California, Berkeley; Dr R. U. Roesler, LN; Dr P. Viette, MNHN.

The photographs were produced by the Photographic Unit, BMNH.

Host-plant relationships within *Mirificarma*

Gelechiid genera are often associated with particular host-plant groups, for example, *Ornativalva* Gozmány – *Tamarix*, *Caryocolum* Gregor & Povolný – Caryophyllaceae. The known host-plants of *Mirificarma* larvae are all Leguminosae. It is sometimes difficult to verify host-plant records since the plant or the moth may have been misidentified; for example, an erroneous record of *eburnella* on *Populus* is based on a misidentification of the moth, which was probably *Schiffermuelleria formosella* ([Denis & Schiffermüller]). Additionally, changes in botanical nomenclature can cause problems, such as the following examples. *Cytisus scoparius* L. was known as *Spartium scoparium* by some authors and records of *Spartium* probably refer to this plant and not to species currently in *Spartium*. *Trifolium* has been used broadly to cover plants in other genera of the Trifolieae such as *Medicago*. Some 'host-plant' records are not based on moths bred from larvae on the plant, but merely on the circumstantial evidence of the presence of the moths around the plant, and may be erroneous. Such errors are often compounded by one author copying another without providing confirmatory data or citing the source of information.

The choice of host-plant does not seem to reflect the systematic relationships of *Mirificarma* within the Gelechiidae. Leguminosae are utilized as larval host-plants by species in several unrelated groups of the Gelechiidae, for example, *Xystophora* Heinemann (Aristoteliinae), *Syncopacma* Meyrick (Anacampsinae), *Dichomeris* Hübner (Dichomerinae) and *Anarsia* Zeller (Chelariinae). In the Gelechiinae, Leguminosae are known as host-plants of several unrelated species in the tribe Gelechiini, including *Lita solutella* (Zeller), *Chionodes lugubrella* (Fabricius) and *Aroga aristotelis* Millièrè. Species of *Gelechia* Hübner, the apparent close relative of *Mirificarma*, utilize a diverse range of host-plants, predominantly Salicaceae, *Juniperus* and Rosaceae.

The host-plants of 11 species of *Mirificarma* are known and are all in the subfamily Papilionoideae. The systematics of the Leguminosae are taken from Polhill & Raven (1981). The Papilionoideae are divided into several groupings of tribes including the epulvinate series, which comprises the temperate herbaceous tribes, which have lost the basal pulvinus of the leaf, and the genistoid alliance, which includes the tribe Genisteae. Four species of *Mirificarma* have, as yet, been recorded from only one host-plant, but seven species have been bred from two or more plant species and *eburnella* and *mulinella* are each known from seven.

Three species-groups are here recognized in *Mirificarma* based on a number of morphological

Table 1 Checklist of the species and subspecies of *Mirificarma*, with host-plant data.

Species and subspecies of <i>Mirificarma</i>	Host-plants of <i>Mirificarma</i> larvae Leguminosae: Papilionoideae	tribes of the epulvinate series	tribe Genisteae
MIRIFICARMA Gozmány, 1955			
<i>Helina</i> Guenée, 1849 [junior homonym]			
<i>montivaga</i> -group			
<i>montivaga</i> (Walsingham, 1904) comb. n.			
<i>pulverosella</i> (Zerny, 1936) syn. n.			
<i>maculatella</i> -group			
<i>scissella</i> (Chrétien, 1915) comb. n.			
<i>rhodoptera</i> (Mann, 1866)			
<i>denotata</i> sp. n.			
<i>maculatella</i> (Hübner, 1796)		Galegeae: <i>Astragalus</i>	
<i>pallidipulchra</i> (Walsingham, 1904) comb. n.		Coronilleae: <i>Coronilla</i>	
<i>striolella</i> (Turati, 1924) syn. n.			
<i>aflavella</i> (Amsel, 1935) stat. n.			
<i>flavella</i> (Duponchel, [1844])			
<i>segetella</i> (Zeller, 1847)			
<i>eburnella</i> ([Denis & Schiffermüller], 1775) comb. n.			
<i>formosella</i> (Hübner, 1796) [junior homonym]			
<i>flammella</i> (Hübner, [1825])			
<i>rufeoformosella</i> (Bruand d'Uzelle, 1859)			
<i>interruptella</i> -group			
<i>ocellinella</i> (Chrétien, 1915) comb. n.			<i>Retama</i>
<i>aurantiella</i> (Chrétien, 1915) syn. n.			
<i>retamaeocellinella</i> (Dumont, 1931) syn. n.			
<i>fasciata</i> sp. n.			
<i>lentiginosella</i> (Zeller, 1839)			<i>Genista</i> , <i>Laburnum</i>
<i>constricta</i> sp. n.			
<i>cytisella</i> <i>cytisella</i> (Treitschke, 1833)			<i>Cytisus</i> , <i>Genista</i> , <i>Calicotome</i> , <i>Laburnum</i>
<i>cytisella leonella</i> Amsel, 1959			
<i>monticolella</i> (Rebel, 1931) comb. n., stat. n.			
<i>interruptella</i> (Hübner, 1793)			<i>Cytisus</i> , <i>Genista</i>
<i>flavonigrella</i> (Chrétien, 1915) comb. n.			
<i>burdonella</i> (Rebel, 1930)			
<i>cabezella</i> (Chrétien, 1925)			<i>Adenocarpus</i>
<i>ulicinella</i> (Staudinger, 1859)			<i>Ulex</i>
<i>mulinella</i> (Zeller, 1839)			<i>Ulex</i> , <i>Cytisus</i> , <i>Genista</i> , <i>Calicotome</i> , <i>Lupinus</i>
<i>camunariella</i> (Fuchs, 1902)			
<i>nigraesilvae</i> (Amsel, 1950)			

characters. The division of the two major species-groups is corroborated by host-plant differences. Host-plants of the *montivaga*-group are unknown. The host-plants of the *maculatella*-group are all in the epulvinate series, in the tribes Loteae, Coronilleae, Trifolieae, Viciae and Galegeae, while the *interruptella*-group has Genisteae host-plants (see Table 1).

One species in the *interruptella*-group, *cytisella*, has *Ononis* as a host-plant, in addition to several species of Genisteae. Although *Ononis* is a member of the Trifolieae, it has some Genisteae-like morphological characters and it has been linked with the Genisteae by early authors (see the discussion of the taxonomic history of *Ononis* by Kupicha, 1977: 134). *Ononis* also has biochemical affinities with the Genisteae, to which it has similar isoflavenoids (see Gomes *et alii*, 1981: 472, 473). It is possible that these characteristics make the plant acceptable to the moth which otherwise selects Genisteae. In addition the host-plant must be acceptable to the larva.

Although *Mirificarma* species within a species-group share host-plants of the same tribe or group of tribes, there is little evidence that the close relationship of species is reflected in the close relationship of their host-plants. In the *maculatella*-group, *eburnella* and *flavella* both occur mainly on Trifolieae, including *Trifolium*. However, *eburnella* also occurs on Coronilleae, the host-plant tribe of *maculatella*, a species to which *eburnella* is less closely related. *M. maculatella* and its sister-species *denotata* use plants of different tribes, Coronilleae and Galegeae respectively.

In the *interruptella*-group, the closely related *mulinella* and *ulicinella* both occur on *Ulex*, although on different species, but *mulinella* shares *Cytisus nigricans*, *Calicotome spinosa* and *Genista* with *cytisella*; *Genista germanica* and *G. tinctoria* with *lentiginosella*, and *Cytisus scoparius* with *interruptella*. *M. mulinella* and *ulicinella* form a close group with *cabezella* which differs considerably from these two in its host-plant *Adenocarpus*, an outlier in the Genisteae.

The distribution of a host-plant has not always restricted the distribution of the moth, which may have adapted to different plants in different parts of its range. For example, *cytisella* was described from specimens bred on *Cytisus nigricans* in Germany, and has subsequently been bred on this, for example, by Klimesch (1961: 651) in Austria. *C. nigricans* does not occur in France (Tutin *et alii*, 1968: 86) and *cytisella* has been recorded there on *Calicotome* and *Ononis*. The ability of some *Mirificarma* species to utilize a range of host-plant genera suggests that they have adapted to different hosts rather than that they have evolved in conjunction with their hosts.

The systematic position of *Mirificarma*

Many species currently in *Mirificarma* were originally described in *Gelechia*, and subsequently listed in this genus by Gaede (1937). However, *Gelechia* has been widely used to include many unrelated species and has been referred to as the microlepidopterist's 'waste-paper box' (Chambers, 1872: 147, and subsequent authors). *Mirificarma* is clearly separated from *Gelechia* (sensu Sattler, 1960) by the presence of a filament on the male genitalia, as well as other characters (see also remarks, p. 15).

Following the original placing of *flavella* in *Acompsia* Hübner, the related species *eburnella* (as *formosella* Hübner) and *pallidipulchra* were also listed in this genus by Meyrick (1925: 142) and Gaede (1937), possibly because *Acompsia* and *Mirificarma* have similar wing venation. *Acompsia* and *Mirificarma* differ, however, in many characters including the male eighth tergite and sternite which are laterally fused in the former but separated in the latter. The three species have also been placed in *Rhinosia* Treitschke, either in the original descriptions or by subsequent authors including Meess (*in* Spuler, 1910: 344), apparently because of a strong superficial similarity to species then in *Rhinosia* but now transferred to *Orophia* Hübner (Oecophoridae). *Orophia ferrugella* ([Denis & Schiffermüller]), formerly in *Rhinosia*, has sometimes been misidentified as *flavella* (see p. 27).

In the original description, *Mirificarma* was placed between *Neofaculta* Gozmány and *Lita* Treitschke, both currently in the subfamily Gelechiinae, without indication as to whether its position was deliberate or arbitrary. Sattler (1960: 41) also placed it among genera currently in the Gelechiinae although its placement between *Lita* and *Aroga* Busck was arbitrary.

The subfamilies of Gelechiidae are mostly poorly defined and the relationships of the genera still require much investigation. However, *Mirificarma* does appear to share some characters with certain other genera within the Gelechiidae. The eighth abdominal tergite and sternite of the male are separated into free flaps in *Mirificarma*. This is usual in the Gelechiinae (tribes Gelechiini, Teleiodini and Gnorimoschemini) whereas the tergite and sternite are normally fused laterally in the rest of the Gelechiidae. The long narrow scales of the coremata of the eighth tergite of *Mirificarma* are similarly placed to those occurring in many Gelechiinae, attached closely to the tergite. Coremata occur in a few genera outside the Gelechiinae, and are probably homologous in some cases, such as in *Deltophora* Janse in the Aristoteliinae, although in this genus the coremata are usually loosely attached to the tergite. The coremata of the male eighth sternite of *Mirificarma*, on the dorsal membrane, consist of enlarged scales with a rounded, often inflated structure. Some Gelechiinae have scales similarly situated, as seen in *Gelechia scotinella* Herrich-Schäffer, *G. hippophaella* (Schrank), *G. nigra* (Haworth) and *Teleiodes myricariella* (Frey), in which the scales are large and sometimes long although not inflated. The scales are deciduous, consequently fresh preparations need to be made to assess how widespread they might be in the Gelechiinae and whether they might occur outside the Gelechiinae. The scales are most similar to those of *Mirificarma* in *Psoricoptera gibbosella* (Zeller), currently in the Hypatiminae although with a number of similarities to *Gelechia* near which it might be better placed.

In common with many Gelechiinae, the posterior apophyses of the female genitalia are often long in *Mirificarma*, although this character is not restricted to this subfamily.

Within the Gelechiinae, *Mirificarma* does not appear to be closely related to the Gnorimoschemini, in which the signum of the female genitalia is a strong hook-like structure. The signum of *Mirificarma* varies interspecifically but is never of this form. *M. montivaga*, which has the least apomorphies of the genus, has a signum similar to that frequently seen in *Gelechia* and the Teleiodini. This type of signum is also found in *Neofriseria* Sattler, currently placed in the Gelechiini although not in close relationship with *Gelechia*, and *Psoricoptera gibbosella*, currently in the Hypatiminae although, as mentioned above, probably more closely related to *Gelechia*. *Mirificarma* does not show evidence of a close relationship with the Teleiodini, in which the male genitalia have frequent modifications not shared by *Mirificarma*, such as a narrow, elongate uncus. The male eighth segment varies in shape in the Teleiodini and usually differs from that of *Mirificarma*. The gnathos is absent in some Teleiodini and if present, usually also differs from that of *Mirificarma*.

The possession of a filament on the male genitalia distinguishes *Mirificarma* from all other Gelechiidae. However, the pair of sclerites which support the filament in *Mirificarma*, extending anteriorly from the base of the sacculus and valva and lying between the vinculum and tegumen, appear to be homologous with similar structures in species of *Gelechia*, particularly *G. sabinella* Zeller, *G. nigra*, *G. rhombella* ([Denis & Schiffermüller]) and *G. senticetella* Staudinger. The sclerites in these species are fused anteriorly, at the region from which the filament would arise in *Mirificarma*. This region is usually membraneous in *Gelechia*, and never a well-sclerotized swelling as in *montivaga* which has the least-developed filament of *Mirificarma*. A membraneous sac is present around the filament and supporting sclerites of *Mirificarma* and this is sometimes also present around the sclerites of *Gelechia*. Slight sclerotized extensions from the base of the sacculus or valva may occur in other genera, such as *Chionodes* Hübner, but it is the development of these into the long sclerites that appears to be a synapomorphy of *Mirificarma* and *Gelechia*.

Thus I consider *Mirificarma* to belong in the Gelechiinae, as delimited above, on account of the structure of the male eighth abdominal segment. Within this subfamily I consider it to be close to *Gelechia*, with which it shares the presence of the sclerites described above.

Classification of *Mirificarma* species

The cladogram (Fig. 2) is based on the list of characters (Table 2) of *Mirificarma* and its presumed close relative *Gelechia*. Further material of *Mirificarma* and related genera would be

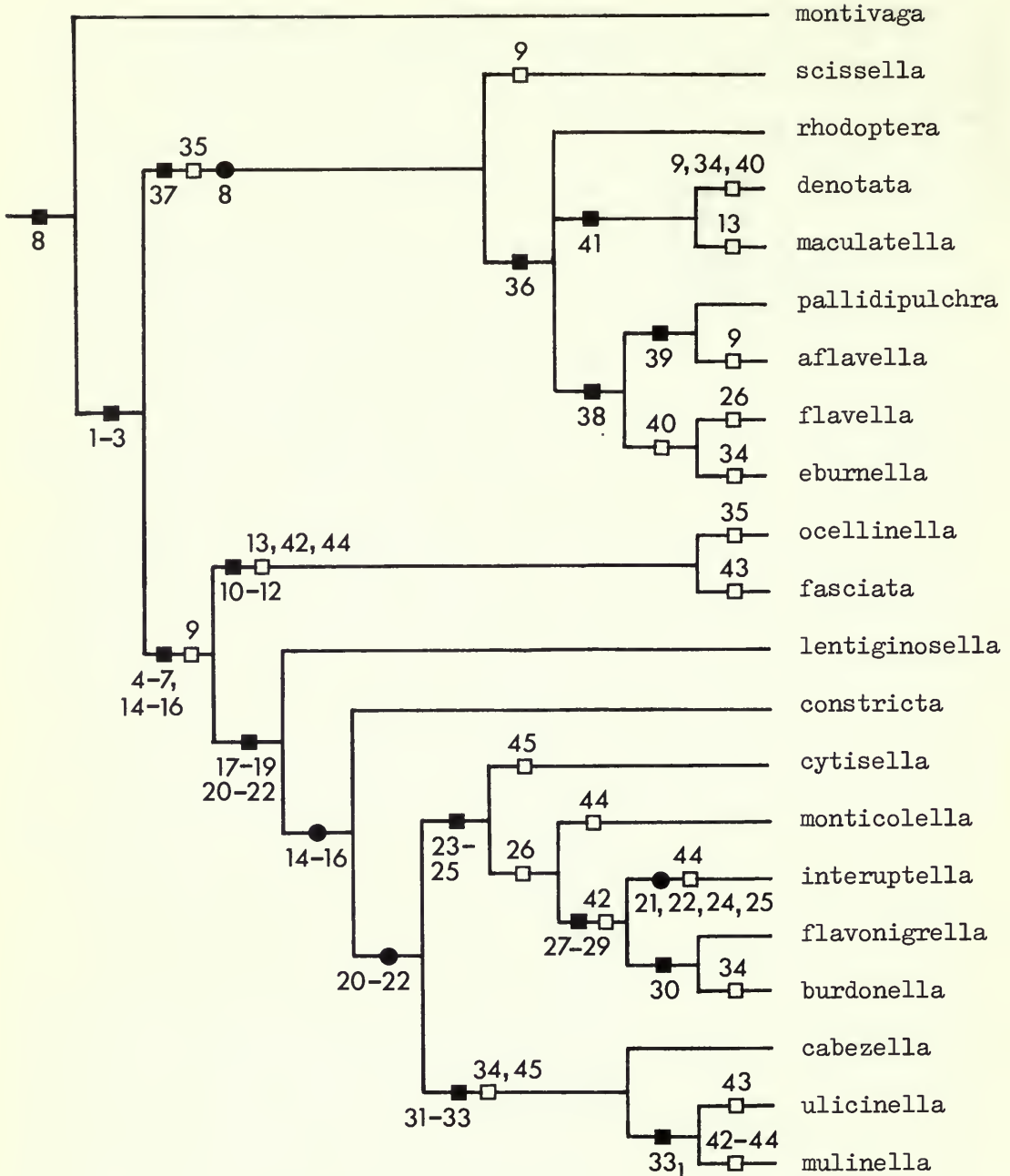

Fig. 2 Cladogram derived from the character matrix for the species of *Mirificarma*. Numbers refer to characters listed in Table 2. Black squares (with numbers below) denote presumed apomorphies, open squares (with numbers above) denote presumed convergences, black circles (with numbers below) denote presumed character-reversals.

required to resolve fully the relationships within *Mirificarma*. Autapomorphies of individual species are not included except where they are presumed to involve character-reversal or convergence. The females of four species are unknown. Intermediate states are scored as apomorphies, with the exception of those discussed in the additional comments on characters 39 and 45. Apparent convergences occur in characters 9, 13, 14, 21, 22, 26, 34, 35, 40, 42–45.

Polarities of characters have been estimated by comparison with the out-group (*Gelechia* and other Gelechiinae), but this has not always been possible and therefore the polarities of some character states are dubious.

From the analysis of the characters examined (Figs 1, 2) *montivaga* has the least apomorphies of the genus, since it is plesiomorphic in characters 1–3, whereas these are apomorphic in all other species of *Mirificarma*. These other species can be divided into two groups, the *maculatella*-group and the *interruptella*-group. The *interruptella*-group is defined by the apomorphic states of characters 4–7 and 14–16, although the last three characters are reversed in some species (see Figs 1, 2). The *maculatella*-group is defined by the apomorphy of character 37 and the reversal of 8. The division of the two species-groups is corroborated by their host-plant relationships (see p. 5).

Within the *maculatella*-group, the relationships of *rhodoptera* are not fully resolved, hence the trichotomy in Fig. 2. In order to resolve the relationships within the *interruptella*-group, reversal of characters 14–16, 20–22, 24 and 25 has been presumed.

The 'Remarks' on each species that follow (p. 19 onwards) reflect the primary concern of this paper, namely species diagnosis and therefore stress similarities and differences between species but do not necessarily indicate their relationships.

Table 2 Characters used in the construction of a cladogram for *Mirificarma*.

Character	State	
	Plesiomorphic	Apomorphic
1 Male filament	very weakly developed	well developed
2 Ductus bursae	extremely long	comparatively short
3 Aedeagus	bulbous in basal half	uniformly slender
4 Vinculum	without sclerites extending from saccus, although sometimes with short faint sclerites extending from anterior margin of vinculum (sclerites of <i>montivaga</i> are more similar to this than to the apomorphic state)	with pair of sclerites or single sclerite extending from saccus towards hind edge of vinculum
5 Uncus	large, slightly narrower than tegumen	small, usually considerably narrower than tegumen (small but narrowing evenly from tegumen in <i>monticolella</i>)
6 Tegumen lateral margins	with pair of small rounded processes (often weak in <i>montivaga</i>)	comparatively even
7 Membrane between papillae anales and eighth abdominal segment of female	with two invaginations	with single invagination
8 Hind edge of vinculum	broadly projecting but without distinctly demarcated median projection	with distinctly demarcated median projection, usually comparatively narrow, or hind edge a narrow projection
9 Hind wing veins R_s and M_1	separate	on common stalk
10 Sacculus	broad, at least basally [this character has four apomorphic states – see also 20, 26, 33]	moderately slender, straight or slightly curved, with one or more small irregular projections at apex

Table 2 – Continued

Character	State	
	Plesiomorphic	Apomorphic
11 Median projection of hind edge of vinculum	not sharply rectangular	sharply rectangular, scarcely emarginate, membranous
12 Projection near apex of aedeagus	relatively broad [this character has three apomorphic states – see also 32, 37]	slight, very narrow, distinctly sclerotized
13 Pair of membranous sacs between apophyses anteriores and antrum	absent	present
14 Antrum	comparatively short	extremely long
15 Saccus	short or moderately long	extremely long
16 Aedeagus/tegumen length ratio	low (at most 1.3)	high (1.7–1.8)
17 Apophyses anteriores	long (at least 0.6 mm)	short (less than 0.6 mm)
18 Female eighth abdominal segment	slightly sclerotized	well sclerotized (either uniformly, or with patches of very strong sclerotization)
19 Filament extent	far beyond hind edge of vinculum	at most a comparatively short distance beyond hind edge of vinculum
20 Sacculus	broad, at least basally [this character has four apomorphic states – see also 10, 26, 33]	slender, moderately curved, with even apex
21 Uncus	not or scarcely constricted at base	constricted at base (more so in <i>constricta</i> than in <i>lentiginosella</i>)
22 Filament	gently curved, slightly helical or straight [this character has two apomorphic states – see also 30]	with apical half kinked, basal half straight
23 Patch of sclerotization at posterior margin of female seventh abdominal segment	faint, diffuse, merging with median longitudinal band or absent	well defined
24 Gnathos	a large hook, or complex	small simple hook-shape
25 Uncus	broad or not narrowing from base towards apex	small and narrowing from base towards apex
26 Sacculus	not stouter apically [this character has four apomorphic states – see also 10, 20, 33]	stouter towards apex (club-shaped or slender and spatulate)
27 Aedeagus apex	not cylindrical	almost cylindrical
28 Apophyses anteriores	rod-like	lobe-like
29 Female eighth sternite	without strongly contrasting areas of sclerotization	strongly sclerotized laterally, contrasting with weakly sclerotized median area
30 Filament	narrowing evenly towards apex [this character has two apomorphic states – see also 22]	with basal half dorsoventrally expanded and laterally compressed

31	Posterior margin of female seventh abdominal segment	with, at most, diffuse band of scales	with distinct, dense band of scales
32	Projection near apex of aedeagus	small, sclerotized, evenly tapering [this character has three apomorphic states – see also 12, 37]	weakly sclerotized, rounded
33	Sacculus	broad, at least basally [this character has four apomorphic states – see also 10, 20, 26]	evenly slender, straight and smooth (the particularly slender sacculus of <i>mulinella</i> and <i>ulicinella</i> represents a further development – 33 ₁)
34	Signum	present	absent
35	Signum	with very many small spines or without spines	with large spines (small spines sometimes also present)
36	Filament-supporting sclerites	not twisted	twisted (weakly twisted in <i>flavella</i>)
37	Projection near apex of aedeagus	small, evenly tapering [this character has three apomorphic states – see also 12, 32]	large, angular, hooked, narrowing to a point
38	Fore wing pattern	small spots or uniform [this character has three apomorphic states – see also 41, 42]	zig-zag yellowish markings
39	Median longitudinal band of sclerotization of female seventh abdominal segment	if present, not or slightly constricted	strongly constricted
40	Antrum	curved or constricted towards apex	straight and not constricted towards apex
41	Fore wing pattern	small spots or uniform [this character has three apomorphic states – see also 38, 42]	large spots
42	Fore wing pattern	small spots or uniform [this character has three apomorphic states – see also 38, 41]	median longitudinal stripe (broken or unbroken)
43	Gnathos	curved	almost straight (short in <i>ulicinella</i> , long in <i>fasciata</i>)
44	Saccus	broad, at least basally	relatively slender
45	Female frenulum	three setae	usually two setae

Additional comments on the characters listed in Table 2

- 5 *M. ocellinella* and *fasciata* are intermediate, more similar to the plesiomorphic than to the apomorphic state.
- 8 *M. montivaga* is classed as intermediate since the hind edge of the vinculum sometimes approaches the apomorphic state.
- 9 This character is not very reliable since both states are found in some species, although one state is always greatly predominant.
- 16 Aedeagus/tegumen length ratio is intermediate in *lentiginosella* (1.4–1.5).
- 18 This character is difficult to observe (since the sclerotization is more obvious in well-stained specimens) but trends of difference between species can be observed. *M. montivaga* has the

- least sclerotization. *M. lentiginosella* and *cytisella* have larger areas of sclerotization than in species with the plesiomorphic state but smaller areas or weaker sclerotization than in the other species with the apomorphic state.
- 19 The species with the longest filaments of the apomorphic state, in relation to tegumen length, are marked as intermediate.
- 21 *M. interruptella* is intermediate between the two states, with the base of the uncus constricted, usually slightly, in a minority of specimens.
- 22 *M. interruptella* is marked as intermediate since the filament is kinked throughout its length.
- 26 The saccus of *flavella* is occasionally stouter apically but is usually more uniformly stout than in the apomorphic state.
- 35 It is impossible to assess this character in *denotata* and the other species in which the signum is absent, or in *eburnella* which has a barely discernible signum.
- 37 The aedeagus projection of *montivaga* (plesiomorphic state) is always small in relation to aedeagus width. *M. rhodoptera* and *eburnella* are intermediate with an aedeagus projection of the derived shape but small. *M. scissella* is intermediate with a more rounded projection than the derived state.
- 39 The derived state is not to be confused with the slight constriction of the band of sclerotization in the several species marked as intermediate and not scored on the cladogram.
- 40 *M. denotata* is classed as intermediate since its antrum narrows towards the apex more than that of *flavella* and *eburnella*. It is not appropriate to score this character in species with an extremely short antrum.
- 42 In the species marked as intermediate both states are present in different specimens.
- 45 Too few specimens have been examined to be certain of the character state of every species, since this character is sometimes very variable intraspecifically. As this character is unstable, only the species which usually have two setae are scored as apomorphic. Species with an equal occurrence of two and three setae or with a tendency towards three setae are classed as intermediate and are not scored on the cladogram. This character seems to show a trend towards a relationship between *mulinella*, *ulicinella* and *cabezella*, which have the apomorphic state, although this is also shared by *cytisella*.

The structure of the filament of the male genitalia

In his original description of *Mirificarma*, Gozmány referred to the filament as 'a very long filamental prong' accompanying the aedeagus. It is orientated longitudinally and is near to the aedeagus in the undissected genitalia, but it has no physical connection with the aedeagus. The aedeagus lies between the ventral surface and the dorsal membrane of the vinculum, whereas the filament is more dorsal, lying between the dorsal membrane of the vinculum and the tegumen. Sattler (1960: 41) compared the filament of *Mirificarma* with processes of the transtilla in *Bryotropha* Heinemann and *Filatima* Busck, but these structures are not homologous with the filament.

The filament is very weakly developed in *montivaga*, in which it is merely a slight sclerotized swelling where the supporting sclerites meet. In all other *Mirificarma* species it is a long, well-sclerotized tube, usually cylindrical, although narrowing gradually, posteriorly, and usually very narrow at the posterior end; usually gently curved or, if very long, sometimes slightly helical. Occasionally the filament is straight, as in *ocellinella*, or modified in shape, for example with a strong kink near the apex in *lentiginosella* and with a projecting lobe in *constricta* and *ulicinella*. The filament varies in length between species, being shortest in relation to tegumen length in *flavonigrella* and *ulicinella*. In the latter, the filament does not usually reach the anterior of the tegumen and extends posteriorly only as far as the hind edge of the vinculum. The filament is longest in relation to tegumen length in *pallidipulchra*, in which it extends very far beyond the anterior of the tegumen and extends posteriorly beyond the uncus.

The filament is open anteriorly and has a small opening near the posterior end. This opening is almost terminal in *flavella* and *ocellinella* whereas it is situated further from the posterior in

maculatella and *cabezella*. In *scissella* a second tiny posterior opening is present. In *ocellinella* and *denotata* a tiny projection occurs from the posterior opening of the filament. In *maculatella* a similar projection is situated more posteriorly. The filament surface of all species appears smooth except for occasional minute spines.

The filament arises from a pair of lateral sclerotized strips, referred to here as filament-supporting sclerites. These extend from the base of the sacculus and, to a less extent, the valva, and meet anteriorly, at which point they fuse to form the filament. The filament is attached only at its anterior, and the length of the sclerites thus varies with the anterior extent of the filament. In many species the filament-supporting sclerites appear to be a smooth continuation of the sacculus. The sclerites are usually parallel-sided over much of their length, at least in the species in which they are long, but they are widened, often considerably and irregularly, towards the sacculus and valva. This expanded area of the sclerite is often faintly rugose and may represent an area of muscle attachment. This feature is not confined to *Mirificarma* since similarly placed, although even fainter, rugose patches are present in *Gelechia nigra*. The filament-supporting sclerites of *Mirificarma* are widened anteriorly, where they meet.

The filament and supporting sclerites are covered ventrally by a membraneous sac which is attached to the sclerites and the anterior end of the filament. The sclerites are spiralled round each other in some species and in these the membrane is similarly twisted. A membraneous sac is usually also present dorsally, from the tegumen. These membranes are flimsy and the dorsal membrane in particular tends to disintegrate during the preparation of genitalia slides. The dorsal membrane is relatively well developed in *cabezella* and *mulinella*, for example, but it is most obvious in *ulicinella*.

The function of the filament is unknown. There is some correlation between its length and that of the female apophyses anteriores. There appears to be no correlation between the length of the filament and that of the aedeagus such as the correlation discussed between the saccus and the aedeagus (see p. 15).

MIRIFICARMA Gozmány

Helina Guenée, 1849: 411. Type-species: *Carcina flammella* Hübner, [1825], by monotypy. [Junior homonym of *Helina* Robineau-Desvoidy, 1830 (Diptera).]

Mirificarma Gozmány, 1955: 308, 309 [keys], 313. Type-species: *Tinea maculatella* Hübner, 1796, by original designation.

♂, ♀. (4.5) 5.0–11.0 mm. Head without frontal modifications. Ocellus present. Proboscis well developed; squamose, particularly at base. Maxillary palpus with four segments. Labial palpus recurved, first segment much shorter than second; third segment approximately same length as second or, rarely, slightly shorter; second segment without brush below or, rarely, with slight to moderate brush. Antenna without pecten on scape. Metascutum with paired group of narrow hair-like scales. Fore wing sometimes with zig-zag pattern of yellowish markings; sometimes with large or small dark spot across fold and another at end of cell; sometimes with dark, median, longitudinal, broken or unbroken stripe; a few species without any of these patterns. Fore wing with veins R_4 and R_5 on long common stalk (Fig. 3); distance R_1 – R_2 slightly greater than, to four times R_2 – R_3 ; M_3 and Cu_1 separate. Hind wing with veins R_s and M_1 on common stalk or separate (Figs 3, 4). Frenulum of female with three or sometimes two long setae.

GENITALIA ♂. Eighth tergite and sternite separated into free flaps. Eighth tergite with pair of coremata consisting of dense brushes of long, thin, hair-like scales, inserted laterally at anterior of tergite and attached to ventral membrane of tergite. Dorsal membrane of sternite with coremata consisting of two groups of large, rounded, often inflated, grape-like scales covering most of sternite. Genitalia withdrawn inside eighth segment. Uncus rounded, often large. Gnathos well-sclerotized, usually simple hook. Gnathos base with small membraneous area densely covered with microtrichia. Tegumen with or without lateral pair of rounded processes. Anterior margin of tegumen with deep V- or occasionally U-shaped emargination. Valva long, usually reaching uncus, slender, simple, slightly swollen at rounded apex. Sacculus clearly separated from valva. Long pair of sclerotized strips present, extending from base of valva and sacculus and meeting anteriorly. Long sclerotized tube (filament) present, arising from where pair of sclerotized strips join; extending posteriorly. In *montivaga*, filament extremely small; merely slight swelling of sclerotization. Hind edge of vinculum usually with medially emarginate median projection. Vinculum extends far posteriorly, hind edge reaching anterior of gnathos in a few species. Vinculum with

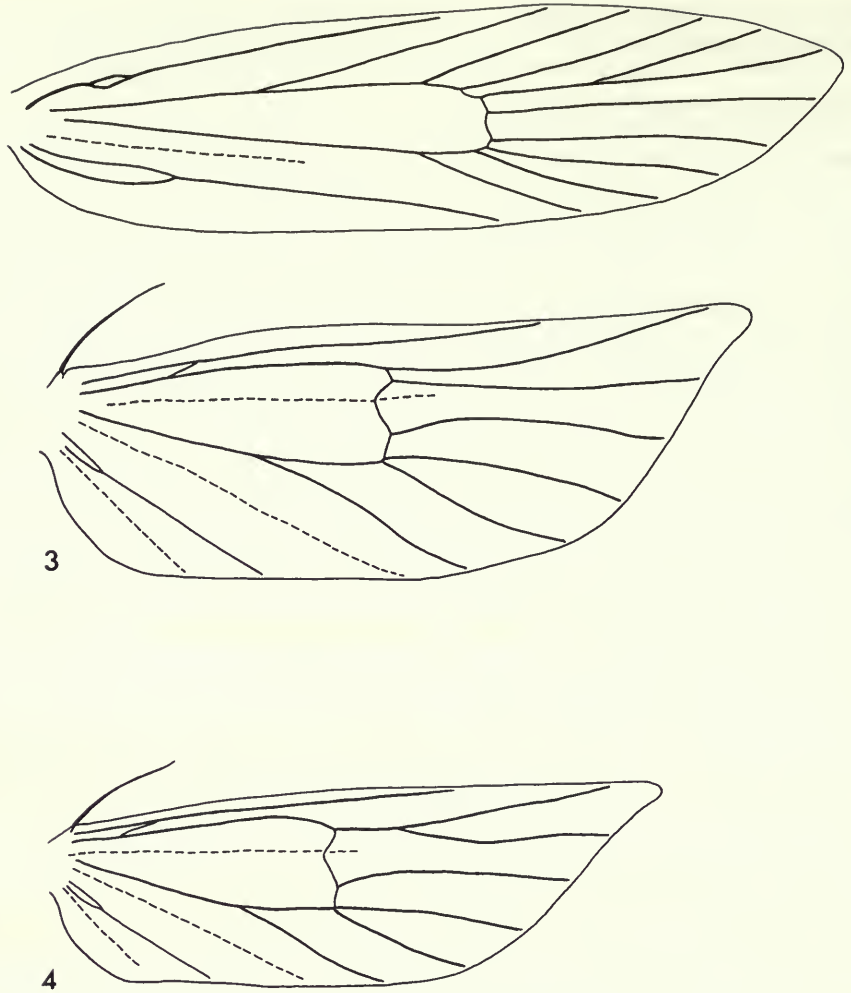

Figs 3, 4 Wing venation of *Mirificarma* species, ♂. 3, *M. maculatella* (Hübner). 4, hind wing of *M. interruptella* (Hübner).

or without pair of narrow sclerites or, exceptionally, single narrow sclerite, extending from saccus towards hind edge of vinculum. Saccus ranging from very slight projection to extremely long. Aedeagus usually cylindrical, slender; occasionally inflated basally; without cornuti. Projection near apex of aedeagus ranging from scarcely discernible to large, hook-like. Anterior part of ductus ejaculatorius often with sclerotized lamina.

GENITALIA. ♀. Dorsal and ventral abdominal surfaces sometimes form broad, median, longitudinal sclerotized band. Posterior margin of seventh segment sometimes with more strongly sclerotized patches. Anterior margin of seventh sternite usually unmodified but in one species (*pallidipulchra*) with pair of sclerites and membraneous sac. Papilla analis usually longer than broad. Invagination of membrane between eighth tergite and papillae anales usually present, immediately opposite invagination, sometimes present, of membrane between sternite and papillae anales. Eighth segment with predominantly lateral areas of sclerotization; occasionally almost completely sclerotized. Apophysis anterior usually rod-like, occasionally short, broad lobe; length 0.2–1.3 mm; apophysis posterior two to six times length of apophysis anterior in each species. Sclerotized antrum present, usually long, nearly as long as apophysis anterior to much longer; occasionally extremely short. Ductus bursae often much shorter than corpus bursae, sometimes longer, exceptionally six times length of corpus bursae. Ductus seminalis arises from posterior part of ductus bursae, usually very near antrum. Corpus bursae with minute spines on inner surface

sometimes sparse, sometimes extending into ductus bursae. Corpus bursae with or without signum. Signum, if present, usually oval or round, usually spinose; spines, if present, directed inside corpus bursae; signum sometimes curved inwards, never hook-like.

REMARKS. The fore wing venation of *Mirificarma* has been checked in nine specimens and is similar to that of many Gelechiidae but appears to differ from that of many *Gelechia* species. In *Mirificarma* the fore wing veins M_3 and Cu_1 are separate whereas these are frequently on a common stalk in *Gelechia*.

The coremata of the male eighth abdominal segment of *Mirificarma* are readily lost during the preparation of genitalia slides although the scale bases can still be seen. The membranous area of the base of the gnathos is much smaller in *Mirificarma* than in *Gelechia* and the Gnorimoschemini in both of which it is an extensive sac. This structure is seen in some genera outside the Gelechiinae, for example *Dichomeris* Hübner and *Acompsia*. The strongly sclerotized hook-shaped gnathos usual in *Mirificarma* occurs in various Gelechiidae but not in *Gelechia*. *Mirificarma* is distinguished by the presence of the filament of the male genitalia (see also the discussions on pp. 5, 6).

The narrow sclerites of the vinculum which extend from the saccus towards the hind edge of the vinculum in the *interruptella*-group of *Mirificarma* are not usually present in the Gelechiidae, although they occur in *Psoricoptera gibbosella* which may be related to *Gelechia* and *Mirificarma* (see p. 6). In the *maculatella*-group the sclerotized anterior margin of the vinculum is occasionally continued towards the median across the posterior of the saccus as a pair of very faint short sclerites. Similar, though longer and very distinct, sclerites occur in the Gnorimoschemini. These sclerites, unlike those of the *interruptella*-group, do not appear to arise from the saccus itself. The vinculum in *Mirificarma* is longest in *interruptella*, sometimes almost reaching the gnathos base of this species.

The aedeagus is usually more slender than in *Gelechia*. There appears to be some correlation between the length of the saccus and the aedeagus in *Mirificarma*. In relation to the tegumen length, these structures are both exceptionally long in *ocellinella* and *fasciata*; in *lentiginosella* they are slightly shorter, although still longer than in the remaining *Mirificarma* species. The saccus is shortest in *rhodoptera* and in this species the aedeagus is also the shortest. In the species with the longest saccus the aedeagus exceeds 1.5 times the length of the tegumen and the sclerotized saccus may serve to support the aedeagus where it extends beyond the tegumen anteriorly. The aedeagus is attached to the anterior of the saccus by retractor muscles in the representative of the Gelechiidae examined by Kuznetsov & Stekol'nikov (1978: 131) and there is a similarly attached muscle in *Mirificarma fasciata*.

Sattler (1976: 93) mentions an apparent correlation between the length of the ductus ejaculatorius of the male and the ductus bursae of the female in the species of *Ornativulva* Gozmány, currently in the Gelechiini, in which these structures are exceptionally long. Likewise, in *Mirificarma*, the ductus ejaculatorius and the ductus bursae are both considerably longer in *montivaga* than in the rest of the genus. There is no obvious correlation in the other *Mirificarma* species, in which both structures are shorter.

Mirificarma species with slight sclerotization of the female eighth sternite often have membranous areas between the apophyses anteriores and the antrum, although the apophyses anteriores and the lateral margins of the antrum are usually continued into the sternite as narrow sclerites, reaching the sclerotized areas of the sternite. In *montivaga* there is little sclerotization of the sternite other than the continuation of the apophyses anteriores. The longitudinal band of the female abdomen in some species of *Mirificarma* is faint and is best observed in well-stained, freshly prepared specimens. I have included this feature in the species diagnoses only when it is characteristic. The band is also present in the male but is less useful as a character for species diagnosis.

The sclerotized antrum of *Mirificarma* is usually long, whereas it is usually very short if present in *Gelechia*. Most *Mirificarma* species have a rounded, spinose signum. Only *montivaga* has a signum of the type common in *Gelechia*, diamond-shaped with a pair of serrated-edged ridges.

BIOLOGY. The known host-plants of *Mirificarma* are all Leguminosae and are discussed under each species and in the section on host-plant relationships. Although most of the species of *Mirificarma* are not known to have any economic significance, *eburnella* has been reported as an agricultural pest in the U.S.A., where it damages clover crops (see p. 28).

The egg stage and site of egg deposition on the host-plant are unknown. The larva makes a spinning amongst the leaves of the host-plant or feeds in the shoots. In plants with small leaves, such as *Ulex*, the larva usually feeds in the flowers. Where details are known, pupation usually takes place in a slight cocoon amongst fallen leaves on the ground, although *eburnella* is recorded as pupating between the leaves on the host-plant. There are few records of the number of generations per year; two species are reputed to have only one generation but two are recorded for *eburnella*. Species may breed continuously where climatic conditions permit as is suggested by the wide range of dates on which *ocellinella* has been collected.

DISTRIBUTION. *Mirificarma* species are distributed in the Palaearctic region between 55° N and 30° S, extending east to c.45°. One species, *eburnella*, also occurs in the U.S.A., where it has been introduced.

Key to the species of *Mirificarma*

Males

- | | | |
|----|---|-------------------------------|
| 1 | Fore wing with large dark spots (Figs 9, 10) | 2 |
| – | Fore wing with small dark spots or different markings | 3 |
| 2 | Fore wing with large dark spot across fold narrowing gradually from middle towards costa; spot at end of cell comparatively distinct from patch at costa (Fig. 10). Portion of aedeagus apical to hook large (Fig. 65) | <i>maculatella</i> (p. 23) |
| – | Fore wing with large dark spot across fold narrowing sharply from middle towards costa; spot at end of cell merging with patch at costa (Fig. 9). Portion of aedeagus apical to hook small (Fig. 64) | <i>denotata</i> (p. 22) |
| 3 | Filament scarcely discernible (Fig. 60) | <i>montivaga</i> (p. 18) |
| – | Filament well developed (Figs 61, 62, 64–82) | 4 |
| 4 | Uncus large, occasionally constricted at base but otherwise only slightly narrower than tegumen (Figs 61, 62, 66–72). Tegumen with pair of rounded lateral processes as in Fig. 31, or if absent, saccus extends far beyond tegumen anteriorly (Figs 70–72) | 5 |
| – | Uncus small, and usually considerably narrower than tegumen; tegumen without rounded lateral processes; saccus extends a comparatively short distance beyond tegumen anteriorly (as in Figs 76, 79–82) | 13 |
| 5 | Tegumen without rounded lateral processes; saccus extends far beyond tegumen anteriorly (Figs 70–72) | 6 |
| – | Tegumen with pair of rounded lateral processes as in Fig. 31; saccus extends at most a short distance beyond tegumen anteriorly (Figs 61, 62, 66–69) | 8 |
| 6 | Filament strongly kinked near apex (Fig. 72) | <i>lentiginosella</i> (p. 32) |
| – | Filament straight (Figs 70, 71) | 7 |
| 7 | Saccus of uniform width; basal half of gnathos increasingly very broad then narrowing sharply to hook-shaped apical half (Figs 46, 71) | <i>ocellinella</i> (p. 29) |
| – | Saccus spatulate, apex approximately twice width of base; gnathos slightly curved, basal half unmodified (Figs 47, 70) | <i>fasciata</i> (p. 31) |
| 8 | Filament not extending beyond apex of valva (Figs 61, 68, 69) | 9 |
| – | Filament extends beyond apex of valva (Figs 62, 66, 67) | 11 |
| 9 | Fore wing with zig-zag pattern of yellowish markings (Figs 11–14). Hind wing with veins <i>Rs</i> and <i>M</i> ₁ separate, as in Fig. 3 | 10 |
| – | Fore wing without yellowish zig-zag markings. Hind wing with veins <i>Rs</i> and <i>M</i> ₁ on common stalk, as in Fig. 4 | <i>scissella</i> (p. 20) |
| 10 | Sacculus with rounded, moderately broad apex (Fig. 68) | <i>flavella</i> (p. 26) |
| – | Sacculus with pointed, moderately slender apex (Fig. 69) | <i>eburnella</i> (p. 27) |
| 11 | Fore wing without zig-zag pattern of yellowish markings. Saccus extremely short and very broad (Figs 35, 36, 62) | <i>rhodoptera</i> (p. 20) |
| – | Fore wing with zig-zag pattern of yellowish markings (Figs 11, 12). Saccus moderately short and broad (Figs 39, 40, 66, 67) | 12 |

- 12 Filament extends far beyond apex of valva posteriorly, and very far beyond tegumen anteriorly (Fig. 66) **pallidipulchra** (p. 24)
 – Filament extends short distance beyond apex of valva posteriorly, and moderately beyond tegumen anteriorly (Fig. 67) **afflavella** (p. 25)
- 13 Sacculus uniformly slender (Figs 73, 80–82) 14
 – Sacculus broad, or broader apically than basally, club-shaped or spatulate; otherwise very small, hook-shaped (Figs 57, 59, 74–79) 17
- 14 Uncus distinctly constricted at base; filament helical in apical half; sacculus gently S-curved (Fig. 73) **constricta** (p. 33)
 – Uncus scarcely constricted at base; filament almost straight or curved dorsoventrally, not helical; sacculus almost straight (Figs 80–82) 15
- 15 Gnathos almost straight; sacculus does not reach gnathos arms (Fig. 81) **ulicinella** (p. 42)
 – Gnathos distinctly curved; sacculus reaches or extends beyond gnathos arms (Figs 80, 82) 16
- 16 Filament stout, particularly basally, laterally compressed apically; median projection of hind edge of vinculum high (Fig. 82) **mulinella** (p. 43)
 – Filament very slender; median projection of hind edge of vinculum low (Fig. 80) **cabezella** (p. 41)
- 17 Sacculus stoutly club-shaped (Figs 57, 76, 78, 79) 18
 – Sacculus slender and spatulate (Fig. 77) or small and hook-shaped (Figs 74, 75) 20
- 18 Gnathos extremely short; saccus very slender; filament extends to hind edge of vinculum or just beyond (Figs 49, 76) **monticolella** (p. 37)
 – Gnathos developed normally; saccus comparatively broad; filament does not reach hind edge of vinculum (Figs 51, 52, 78, 79) 19
- 19 Sacculus scarcely extends beyond median projection of hind edge of vinculum (Fig. 79) **burdonella** (p. 40)
 – Sacculus extends far beyond median projection of hind edge of vinculum (Fig. 59) **flavonigrella** (p. 39)
- 20 Gnathos very large, without median spine; sacculus long, slender, spatulate (Fig. 77) **interruptella** (p. 38)
 – Gnathos small, with median, sometimes minute, spine; sacculus small, hook-shaped (Figs 74, 75) **cytisella** (p. 34)

Females

Note. The females of *scissella*, *monticolella* and *flavonigrella* are unknown; *constricta* is also omitted since the female genitalia are unknown.

- 1 Fore wing with large dark spots (Figs 9, 10) 2
 – Fore wing with small dark spots or different markings 3
- 2 Fore wing with large dark spot across fold narrowing gradually from middle towards costa; spot at end of cell comparatively distinct from patch at costa (Fig. 10). Signum present; antrum curved towards anterior, without indented anterior (Fig. 89) **maculatella** (p. 23)
 – Fore wing with large dark spot across fold narrowing sharply from middle towards costa; spot at end of cell merging with patch at costa (Fig. 9). Signum absent or scarcely discernible; antrum straight, with indented anterior (Fig. 88) **denotata** (p. 22)
- 3 Antrum same length as apophysis anterior or shorter (Figs 85–87, 90–92, 98) 4
 – Antrum extends beyond apophysis anterior (Figs 94, 96–103) 10
- 4 Antrum extremely short (Figs 85, 98) 5
 – Antrum comparatively long (Figs 86, 87, 90–92) 6
- 5 Signum a narrow ridge with faint surround (Fig. 98). Ductus bursae slightly longer than corpus bursae or of similar length **cytisella** (p. 34)
 – Signum elongate-oval to diamond-shaped with serrated edge (Fig. 85). Ductus bursae approximately four to six times length of corpus bursae **montivaga** (p. 18)
- 6 Antrum almost straight, narrowing evenly towards anterior (Figs 92, 93). Fore wing with zig-zag pattern of yellowish markings (Figs 13, 14) 7
 – Antrum curved or constricted towards anterior (Figs 86, 90, 91); if not curved and only very slightly constricted (Fig. 87), forewing without zig-zag pattern of yellowish markings 8
- 7 Antrum with rounded or scarcely indented anterior; abdomen with distinct, longitudinal, median band (Figs 93, 109) **eburnella** (p. 27)
 – Antrum with strongly indented anterior (Fig. 92); abdomen with, at most, very faint band **flavella** (p. 26)
- 8 Abdomen with pair of sclerites and membraneous sac at anterior margin of seventh segment (Fig. 107) **pallidipulchra** (p. 24)

- Abdomen with unmodified anterior margin of seventh segment 9
- 9 Signum with approximately three or four large spines projecting from one side, otherwise smooth; seventh abdominal segment comparatively broad (Figs 91, 108) *aflavella* (p. 25)
- Signum covered with numerous spines of various sizes; seventh abdominal segment narrow (Figs 86, 87, 105, 106) *rhodoptera* (p. 20)
- 10 Antrum very long, coiled or strongly curved (Figs 94, 96, 97) 11
- Antrum moderately long, not coiled or strongly curved (Figs 98–103) 13
- 11 Apophyses anteriores parallel, long; pair of membranous sacs from sternite, between apophyses anteriores and antrum (Figs 94, 96) 12
- Apophyses anteriores diverging, short; without sacs between apophyses anteriores and antrum (Fig. 97) *lentiginosella* (p. 32)
- 12 Apophysis posterior three to four times length of apophysis anterior. Unsclerotized median area of eighth sternite at least as wide as each lateral sclerotized area (Fig. 94) *ocellinella* (p. 29)
- Apophysis posterior twice length of apophysis anterior. Unsclerotized median area of eighth sternite narrower than each lateral sclerotized area (Fig. 96) *fasciata* (p. 31)
- 13 Apophysis anterior lobe-shaped; eighth sternite strongly sclerotized laterally, contrasting with weak sclerotization of median area (Figs 99, 100) 14
- Apophysis anterior rod-like (Figs 93, 101–103); eighth sternite slightly more sclerotized laterally than medially 15
- 14 Signum present; median area of eighth sternite without horizontal striations (Fig. 99) *interruptella* (p. 38)
- Signum not discernible; median area of sternite with horizontal striations (Fig. 100) *burdonella* (p. 40)
- 15 Antrum straight, narrowing evenly towards anterior; abdomen with median longitudinal band, very distinct in seventh segment (Figs 93, 109) *eburnella* (p. 27)
- Antrum curved and constricted towards anterior (Figs 101–103); seventh abdominal segment without median longitudinal band 16
- 16 Base of apophysis anterior with separate rounded lobe towards antrum (Fig. 101) *cabezella* (p. 41)
- Base of apophysis anterior without separate lobe (Figs 102, 103) 17
- 17 Eighth tergite with pair of curved sclerotized lobes overlapping median longitudinal area (Fig. 102) *ulicinella* (p. 42)
- Eighth tergite without lobes (Fig. 103) *mulinella* (p. 43)

The *montivaga*-group

Characters as described under *montivaga*.

Mirificarma montivaga (Walsingham) **comb. n.**

(Figs 1, 2, 6, 32, 33, 60, 85, 104)

Gelechia montivaga Walsingham, 1904: 221. LECTOTYPE ♂, ALGERIA (BMNH), here designated [examined].

Gelechia pulverosella Zerny, 1936: 137, pl. 2, fig. 44. LECTOTYPE ♂, MOROCCO (NM), here designated [examined]. **Syn. n.**

♂, 7.5–8.5 mm. ♀, 7.0–7.5 mm. Head cream. Labial palpus cream mottled with brown on outer surface. Thorax, tegula and fore wing (Fig. 6) cream to light brown mottled with brown. Hind wing with veins *Rs* and *M*₁ separate as in Fig. 3.

GENITALIA ♂ (Figs 32, 33, 60). Uncus large, only slightly narrower than tegumen. Gnathos a moderately large simple hook. Tegumen with pair of rounded lateral processes, sometimes very slight. Actual margin of tegumen slightly less emarginate than sclerotized margin anteriorly; sclerotized margin distinctly X-shaped medially. Sacculus moderately broad. Filament scarcely discernible; filament-supporting sclerites not twisted around each other. Hind edge of vinculum a broad projection, scarcely emarginate medially. Vinculum short, with pair of very short faint sclerites converging from anterior edge. Saccus narrowing slightly towards rounded apex, extending short to moderate distance beyond tegumen anteriorly. Aedeagus same length as tegumen plus uncus or slightly shorter. Aedeagus with bulbous basal half, small to moderate projection near apex, and long ductus ejaculatorius.

GENITALIA ♀ (Figs 85, 104). Posterior margin of seventh abdominal segment with faint dorsal patch of sclerotization and pair of narrow longitudinal stripes ventrally. Very flimsy, broad, rounded invagination

of membrane between eighth tergite and papillae anales, directly opposite less flimsy, long, narrow invagination of membrane between sternite and papillae anales. Eighth segment with very weak sclerotization, longitudinally wrinkled, minutely spined anteriorly. Apophysis anterior rod-like, length 0.8–0.9 mm (2); apophysis posterior approximately three times length of apophysis anterior. Antrum slightly indented at anterior and extremely short. Ductus bursae gently coiled, narrow; coiled extent approximately four to six times length of oval or round corpus bursae. Signum very large, elongate oval to diamond shape, with deep longitudinal indentation edged with pair of serrated-edged projecting ridges.

REMARKS. The frenulum was examined in the four females and consists of three setae in three of these and two setae in one, on both wings. The X-shaped anterior margin of the tegumen is particularly distinct in *montivaga*, although it occurs to a less degree in *constricta* and is very weak in several other *Mirificarma* species.

M. montivaga is the only species of the genus in which the fore wing has no pattern other than the mottling of the ground colour, although the markings are extremely small in *monticolella*, *lentiginosella* and a few specimens of *ocellinella*. The ground colour is much darker in *lentiginosella*. *M. montivaga* differs from the rest of the genus in genital characters including the scarcely discernible male filament which is merely represented by a slight swelling between the supporting sclerites, the shape of the signum and the extremely long ductus bursae of the female. The long ductus bursae approaches that of *rhodoptera*, but this species has a much longer antrum than *montivaga*.

M. montivaga was described from 3 ♂, 3 ♀ from Algeria: El Kantara, all of which I have examined. I designate the specimen bearing Walsingham's number 96484 as the lectotype. This is referred to as the 'Type ♂' on the specimen label and in the original description in which the date of capture is given as 3.v.1903; however, 1 ♂, 1 ♀, bearing Walsingham's paratype labels, are labelled 9.v.1903.

G. pulverosella was described from 8 ♂, 5 ♀ from Morocco, of which I have examined 3 ♂, 1 ♀. Of these 1 ♂, 1 ♀ bear the labels 'Type ♂' and 'Type ♀' respectively and I designate the male as the lectotype. The 5 ♂, 4 ♀ syntypes which I have not examined are from Tachdirt, middle and end vii (*Zerny*).

BIOLOGY. Host-plant unknown. Moths have been found from May to July.

DISTRIBUTION. Morocco and Algeria.

MATERIAL EXAMINED (including 6 ♂, 3 ♀ genitalia preparations)

Lectotype ♂ (*montivaga*), **Algeria**: [Constantine province,] El Kantara, 3.v.1903 (*Walsingham*) (genitalia slide no. 7124). Lectotype ♂ (*pulverosella*), **Morocco**: Haut ('Grosser') Atlas, c. 17 km SE. of Asni, in highest Iminene Valley, Tachdirt, 2200–2900 m, 11–19.vii.1933 (*Zerny*) (genitalia slide no. 11223; NM).

Morocco: 1 ♂ (*pulverosella* paralectotype), Haut Atlas, c. 70 km SW. of Marrakech, Goundafa area, 3 km above Kasbah Goundafa, at junction of Agoundi Valley in Fis Valley, 'n Zala, above Ijjoukak, 1500–1800 m, 21–29.vi.1933 (*Zerny*) (NM); 1 ♂, Haut Atlas, Oukaïmedene, 2500–2900 m, vii (coll. Burmann, Innsbruck); 1 ♂, 1 ♀ (*pulverosella* paralectotypes), Haut Atlas, Tachdirt, 2200–2900 m, 11–19.vii.1933 (*Zerny*) (NM); 1 ♂, Moyen Atlas, Val d'Ifrane, 1600–1700 m, vi (coll. Burmann, Innsbruck). **Algeria**: 2 ♂, 3 ♀ (*montivaga* paralectotypes), El Kantara, 3, 9.v.1903 (*Walsingham*).

The maculatella-group

♂, ♀. Fore wing sometimes with zig-zag pattern of yellowish markings; without median longitudinal stripe. Hind wing with veins *Rs* and *M*₁ separate or on common stalk.

GENITALIA ♂. Uncus large, only slightly narrower than tegumen. Gnathos a large simple hook. Tegumen with pair of rounded lateral processes. Filament-supporting sclerites usually crossed or spiralled round each other. Hind edge of vinculum a low, broad, sclerotized projection, usually with broad emargination, but without distinctly demarcated median projection. Vinculum without sclerites which extend from saccus and approach hind edge of vinculum. Projection near aedeagus apex usually large, angular and narrowing to point.

GENITALIA ♀. Invagination of flimsy membrane between eighth tergite and papillae anales present, immediately opposite invagination of slightly less flimsy membrane between sternite and papillae anales. Eighth segment weakly sclerotized. Apophysis anterior rod-like, long. Signum, if well developed, with large spines; small spines sometimes also present.

REMARKS. The filament-supporting sclerites of the male genitalia are more strongly spiralled round each other in the species in which they are long, particularly *maculatella* and *rhodoptera*. Although the vinculum does not have sclerites extending from the saccus and approaching the hind edge of the vinculum, in a few species the anterior margin of the vinculum is continued towards the median as faint, narrow, short sclerites on either side of the saccus. This is seen in *rhodoptera* and *pallidipulchra* and, even more faintly, in one specimen of *aflavella*; in *scissella* the anterior margin of the vinculum is sometimes continuous across the saccus posterior as a narrow sclerite. The sclerotization of the eighth segment is uniformly weak or limited to smaller areas than in most of the *interruptella*-group, but is always greater than in *montivaga*.

BIOLOGY. Host-plants: Trifolieae (other than *Ononis*); Loteae; Coronilleae; Galegeae; Viciae.

***Mirificarma scissella* (Chrétien) comb. n.**

(Figs 1, 2, 7, 34, 61)

Gelechia scissella Chrétien, 1915: 319. LECTOTYPE ♂, ALGERIA (MNHN), here designated [examined].

♂, 7.0–7.5 mm. Head whitish cream. Labial palpus cream, mottled with brown at base. Thorax and tegula cream mottled with brown. Fore wing (Fig. 7) cream to pale brown, mottled with brown; slightly darker at extreme base and at costa in four-fifths. Dark brown spot across fold at one-third with trace at dorsal margin. Small dark brown spot at end of cell. Hind wing with veins *R*_s and *M*₁ on common stalk as in Fig. 4.

GENITALIA ♂ (Figs 34, 61). Actual margin of tegumen less emarginate than sclerotized margin anteriorly. Sacculus broad at base, slightly wrinkled at narrower apex. Filament very slightly curved, slender, not reaching apex of valva posteriorly, extending short to moderate distance beyond tegumen anteriorly. Filament-supporting sclerites not or scarcely twisted. Hind edge of vinculum with shallow U- or V-shaped emargination of sclerotization. Saccus usually moderately broad, scarcely narrower towards rounded apex, extending short distance beyond tegumen anteriorly. Aedeagus approximately same length as tegumen plus uncus, slender; apical projection moderately large, not distinctly pointed.

GENITALIA ♀. UNKNOWN.

REMARKS. This species bears a superficial resemblance to *rhodoptera*, *constricta* and *cabezella*, although the head is paler and the spot in the fold of the fore wing scarcely extends to the dorsal margin; however, the only specimens known of *scissella* are in poor condition externally. It differs from *rhodoptera* in the hind wing venation, and the shorter filament and longer saccus of the male genitalia. It differs from *constricta* and *cabezella* in some genitalic characters, including the presence of a pair of rounded processes on the male tegumen, since these last two species are in the *interruptella*-group.

M. scissella was described from an unspecified number of specimens of which I designate as lectotype the single type-specimen examined. The coating of debris on this specimen renders it almost unrecognizable externally. One of the rounded processes of the tegumen is absent in the lectotype.

BIOLOGY. Host-plant unknown. Moths have been found in April and May.

DISTRIBUTION. Algeria.

MATERIAL EXAMINED (including 2 ♂ genitalia preparations)

Lectotype ♂, Algeria: [Constantine province,] Biskra, 7.v.1907 (genitalia slide no. 43, LMP; MNHN).

Algeria: 1 ♂, M'zab ('Uzab') country, Oued Nsa ('Nza'), iv; 1 ♂, Hamman-es-Salahine, iv.

***Mirificarma rhodoptera* (Mann)**

(Figs 1, 2, 8, 35, 36, 62, 63, 86, 87, 105, 106)

Gelechia rhodoptera Mann, 1866: 353, pl. 1 (B), fig. 10. Holotype ♂, RUMANIA ('Turkey') (NM) [examined].

♂, 5.0–7.5 mm, ♀, 5.5–7.0 mm. (Typical form. ♂, 6.5–7.5. ♀, 6.0–7.0. Small form. ♂, 5.0–6.5 mm. ♀, 5.5–6.0 mm.) Both forms. Head mid brown. Labial palpus mottled cream and brown; darker on outer surface. Thorax and tegula mottled mid brown. Fore wing (Fig. 8) mottled light brown, very faintly

pink-tinged, and dark brown; darker at base and in apical third; ochreous tinge near base. Small cream patch at costa at two-thirds extending diffusely to dorsal margin. Narrow, transverse dark brown spot across fold at one-third extending to dorsal margin. Smaller dark brown spot at end of cell, constricted medially, occasionally bisected. Both spots with ochreous cream surround. Very small diffuse dark brown spot in fold at one-fifth. Hind wing with veins *Rs* and M_1 separate as in Fig. 3.

GENITALIA ♂ (Figs 35, 36, 62, 63). Actual margin of tegumen less emarginate than sclerotized margin anteriorly. Sacculus short, moderately broad, wrinkled. Filament slightly helical, slender, extending posteriorly moderately beyond apex of valva, and very far beyond tegumen anteriorly. Hind edge of vinculum with broad, shallow U- or V-shaped emargination of sclerotization. Saccus very broad, usually with very shallow emargination at apex; extremely short, never reaching anterior margin of tegumen. Aedeagus approximately three-quarters length of tegumen plus uncus, basal half very slightly swollen; apical projection small.

GENITALIA ♀ (Figs 86, 87, 105, 106). Posterior margin of seventh abdominal segment with area of weak sclerotization merging with progressively faint median longitudinal band. Seventh abdominal segment comparatively narrow, anterior margin unmodified. Invagination of membrane between eighth sternite and papillae anales indistinct, extremely long and narrow. Eighth sternite with lateral pair of weakly sclerotized strips. Tergite and rest of sternite very weakly sclerotized, with minute spines mainly on sternite extending into posterior of antrum. Apophysis anterior length in typical form 1.2–1.3 mm (3); small form 0.6–0.7 mm (3); apophysis posterior twice length of apophysis anterior in each form. Antrum scarcely curved; anterior sometimes slightly indented, particularly in small form. Antrum of typical form very broad posteriorly, constricted strongly to narrow anterior half; shorter than apophysis anterior. Antrum of small form moderately broad posteriorly, constricted comparatively slightly for short distance at anterior; almost as long as apophysis anterior. Ductus bursae approximately two to four times length of oval corpus bursae. Signum covered with large and small spines; signum of typical form large, elongate kidney-shape, strongly curved inwards; signum of small form comparatively small, oval to broad kidney-shape, scarcely curved inwards.

REMARKS. One specimen has veins *Rs* and M_1 on a very short common stalk in one hind wing. The frenulum, examined in seven females, consists of three setae in three of these, two setae in one of these, and in three it consists of three setae on one wing and two on the other.

The specimens examined from Lakonia in Greece are smaller, on average, than the typical form, particularly in the genitalia. The small form is typical externally except that the fore wing markings tend to be relatively slightly smaller. Apart from the size, the female genitalia show some consistent differences in structure from the typical form. The eighth sternite has slightly longer, narrower sclerotized strips than in the typical form, the narrow anterior part of the antrum is considerably shorter and the signum differs in shape. The saccus is variable in length but tends to be more pronounced in the small form. It is possible that the Lakonia specimens may prove to be a distinct species; however, the differences are comparatively slight for the genus. There is insufficient material to determine whether the Lakonia population represents a distinct subspecies of *rhodoptera*. The few specimens I have seen from other Greek localities are of the typical form. A difference in the genitalia of one sex within a species is also discussed for *cytisella* (see p. 34).

M. rhodoptera bears a superficial resemblance to *scissella*, *constricta* and *cabezella*. It differs from all these in the hind wing venation, and the very long filament and very short saccus of the male genitalia, and in addition differs from *constricta* and *cabezella* in many genitalic characters since these two species are in the *interuptella*-group.

BIOLOGY. Host-plant unknown. Moths of the typical form have been found in June and July, those of the small form in May and June.

DISTRIBUTION. Rumania, Greece, Turkey, Lebanon.

MATERIAL EXAMINED

Typical form (including 4 ♂, 4 ♀ genitalia preparations)

Holotype ♂, **Rumania** ('Turkey'): Dobrogea ('Dobrudscha'), far outside Tulcea ('Tultscha'), middle vi.1865 (*Mann*) (genitalia slide no. 11225; NM).

Greece: 1 ♀, Parnass[ós] Mts, vii (MNHU); 1 ♂, 3 ♀, Pelop[ónnisos], near Kalav[rita], Zakhlorou, vi

(Coll. Klimesch, Linz). **Turkey:** 1 ♀, Maraş ('Marasch'), vii (MNHU). **Lebanon:** 2 ♂, N., Bcharre ('Becharré'), 1400 m, vi, vii (NM).

Small form (including 3 ♂, 4 ♀ genitalia preparations)

Greece: 1 ♀, Lakonía, 7 km SW. of Monemvasía, v; 4 ♂, 5 ♀, Lakonía, 5 km S. of Monemvasía, v, vi; 1 ♂, Lakonía, Mt Taygetos, 1000 m, vi (all ZM).

***Mirificarma denotata* sp. n.**

(Figs 1, 2, 9, 37, 64, 88)

♂, 7.5–8.5 mm. ♀, 7.0–8.0 mm. Head light or occasionally mid brown. Labial palpus first and third segments dark brown and cream; second segment predominantly cream. Thorax and tegula brown; tegula base usually darker. Fore wing (Fig. 9) mottled brown and light pink-grey, ochreous tinge near base; apical quarter to third predominantly dark brown, edged with diffuse, basal, transverse pink and cream streak pronounced at costa; moderately dark brown patches slightly basal to streak at costa and dorsal margin, and at base. Large transverse dark brown spot across fold at one-third extending to dorsal margin, narrowing sharply from middle towards costa; dark brown spot at end of cell merging with patch at costa, comparatively distinct from patch at dorsal margin. Both spots with narrow yellow-ochre surround. Hind wing with veins *Rs* and M_1 on common stalk as in Fig. 4.

GENITALIA ♂ (Figs 37, 64). Actual margin of tegumen less emarginate than sclerotized margin anteriorly. Saccus short, moderately broad, flattened, slightly wrinkled at apex. Filament slightly helical, slender, extending posteriorly short distance beyond valva, and well beyond tegumen anteriorly. Hind edge of vinculum with moderately shallow U- or V-shaped emargination of sclerotization. Saccus broad basally, narrow apically, extending slightly beyond tegumen anteriorly. Aedeagus approximately same length as tegumen plus uncus. Aedeagus portion apical to hook small; apical hook moderately large.

GENITALIA ♀ (Fig. 88). Posterior margin of seventh abdominal segment with area of weak sclerotization mainly on tergite. Invagination of membrane between eighth sternite and papillae anales indistinct, long narrow tube without sac. Flimsy membrane between eighth tergite and papillae anales invaginated to broad rounded pouch. Eighth sternite with lateral pair of narrow, longitudinal sclerotized strips. Tergite and rest of sternite very weakly sclerotized, with faint longitudinal wrinkles. Apophysis anterior length 0.9–1.1 mm (2); apophysis posterior approximately three times length of apophysis anterior. Antrum almost straight, narrowing considerably towards indented anterior; approximately same length as apophysis anterior. Antrum with minute spines mainly in posterior half. Ductus bursae approximately twice length of oval corpus bursae. Signum absent or scarcely discernible.

REMARKS. One specimen has the veins *Rs* and M_1 just separate in one hind wing. The frenulum was examined in one female and consists of three setae. During the preparation of the male genitalia, a tiny narrow projection was seen near the apex of the filament of one specimen, similar to that visible in *maculatella* and *ocellinella*, although not obviously tubular as in the latter.

M. denotata is very similar to *maculatella* in the fore wing pattern, but differs very slightly in the form of the two large fore wing spots. The hind wing venation of *denotata* usually differs from that of *maculatella*. The male genitalia are very similar to those of *maculatella* although the shape of the extreme apex of the aedeagus differs; the female genitalia differ from those of *maculatella* in characters including the shape of the antrum and the absence of a signum.

BIOLOGY. Host-plant: Galegeae: *Astragalus lusitanicus* Lamarck (type-specimens bred by Walsingham). The moths emerged in late April and May.

DISTRIBUTION. MOROCCO.

MATERIAL EXAMINED (including 3 ♂, 2 ♀ genitalia preparations)

Holotype ♂, **Morocco:** [SE. of Tanger], El Fendek ('Fondak'), larva 28.iv.1902, on *Astragalus lusitanicus*, moth emerged 27.v.1902 (*Walsingham*) (genitalia slide no. 22027).

Paratypes. 4 ♂, 2 ♀, same data as holotype, moths emerged 22–30.v.1902.

Mirificarma maculatella (Hübner)

(Figs 1–3, 10, 38, 65, 89)

Tinea maculatella Hübner, 1796: 60, pl. 24, fig. 162 [legends to figs 161 and 162 are transposed].

LECTOTYPE ♂, EUROPE (NM), here designated [examined].

Gelechia maculatella (Hübner) Stainton, 1865: 228, pl. 7, fig. 3.[*Gelechia vicinella* Douglas; Bruand d'Uzelle, 1858: 481; Disqué, 1908: 65. Misidentifications.]

♂, 7.0–9.5 mm. ♀, 7.5–9.0 mm. Head mottled mid brown. Labial palpus mottled cream or light brown, and dark brown. Thorax and tegula mottled mid brown. Fore wing (Fig. 10) mottled brown and light pink-grey; ochreous tinge near base; apical quarter to third predominantly dark brown, edged with diffuse, basal, transverse pink and cream streak pronounced at costa; moderately dark brown patches slightly basal to streak at costa and dorsal margin, and at base. Large transverse dark brown spot across fold at one-third extending to dorsal margin, narrowing gradually from middle towards costa; dark brown spot at end of cell comparatively distinct from patch at costa, usually merging with patch at dorsal margin. Both spots with narrow ochreous surround. Hind wing with veins *Rs* and *M*₁ separate (Fig. 3).

GENITALIA ♂ (Figs 38, 65). Actual margin of tegumen less emarginate than sclerotized margin anteriorly. Saccus short, broad, slightly flattened, strongly wrinkled at apex and inner edge. Filament slightly helical, slender, extending posteriorly well beyond apex of valva, and anteriorly, beyond tegumen. Hind edge of vinculum with broad, moderately shallow U- or V-shaped emargination of sclerotization. Saccus broad basally, narrow apically, extending a short distance beyond tegumen anteriorly. Aedeagus slightly longer than tegumen plus uncus. Aedeagus portion apical to hook large; apical hook large.

GENITALIA ♀ (Fig. 89). Posterior margin of seventh abdominal segment with small area of weak sclerotization mainly on tergite. Invagination of membrane between eighth sternite and papillae anales very long narrow tube ending in pronounced, large oval sac. Eighth sternite with lateral pair of broad, moderately short sclerotized strips. Tergite and rest of sternite very weakly sclerotized; tergite with faint longitudinal wrinkles. Apophysis anterior length 0.9–1.0 mm (6); apophysis posterior approximately twice length of apophysis anterior. Membranous area between antrum and each apophysis anterior produced into slight lobe, covered in minute spines. Antrum curved and narrower towards anterior; anterior not indented; approximately 1.5 times to less than twice length of apophysis anterior. Antrum with minute spines mainly in posterior half and extending into median area of sternite. Ductus bursae shorter than or of similar length to round corpus bursae. Signum moderately large, round or oval; with spines, large around edge.

REMARKS. In approximately 7 per cent of the specimens examined the veins *Rs* and *M*₁ are on a common stalk in one or both hind wings. The frenulum of five out of six females examined consists of three setae; in the remaining female it consists of three setae on one wing and two on the other. During the preparation of the male genitalia, a tiny narrow projection was seen near the apex of the filament, similar to those in *denotata* and *ocellinella*, although not obviously tubular as in the latter.

The fore wing pattern of *maculatella* clearly distinguishes it from all other species except *denotata* to which it is very similar. For differences from *denotata* see p. 22.

M. maculatella was described from an unspecified number of specimens. In the NM there is one specimen from Mazzola's collection, here designated as lectotype, already labelled 'lectotype' by Sattler.

BIOLOGY. Host-plants: Coronilleae: *Coronilla varia* L. (moths bred by Mühlig, W. Germany; Stainton, 1865: 228). *C. emerus* L. (Bruand d'Uzelle, 1858: 482, as *Gelechia vicinella* Douglas; also subsequent authors).

The larva occurs in May and June feeding in two opposite leaflets spun together. It pupates in a slight cocoon on the ground (Stainton, 1865: 228). Stainton records only one generation per year. Pröse (1957: 111) records the larva in July. Moths have been collected from June to August.

DISTRIBUTION. France; Germany; Austria; Czechoslovakia; Yugoslavia; Turkey; Syria.

Additional records. Switzerland (Müller-Rutz, 1914: 489); Italy (Hartig, 1964: 27); Poland (Schille, 1931: 179); Hungary (Gozmány, 1958: 227); Albania (Rebel, 1931: 146); U.S.S.R.: Ukraine (Piskunov, 1981: 674).

MATERIAL EXAMINED (including 8 ♂, 6 ♀ genitalia preparations)

Lectotype ♂, **Europe** (*Mazzola*) (genitalia slide no. 11221; NM).

France: 1 ♂, 1 ♀, Paris; 1 ♂, Basses-Alpes, viii. **Germany:** 1 ♂, —; 1 ♂, 1 ♀, 'N. Germany'. **Germany (West):** 1 ♂, 4 ♀, Hessen, vii; 1 ♂, 2 ♀, Bayern. **Germany (East):** 8 ♂, 11 ♀, Gera. **Austria:** 1 ♂, Nieder-Österreich, vii. **Czechoslovakia:** 1 ♂, Bohemia (NM). **Yugoslavia:** 1 ♂, Croatia (NM); 1 ♀, Dalmatia (NM); vi. **Turkey:** 1 ♂, Konya, vii (NM); 1 ♂, Amasya (MNHU). **Syria:** 1 ♀, NW., vi (NM). No locality data: 15 ex.

***Mirificarma pallidipulchra* (Walsingham) comb. n.**

(Figs 1, 2, 11, 39, 66, 90, 107)

Rhinosia pallidipulchra Walsingham, 1904: 269. LECTOTYPE ♂, ALGERIA (BMNH), here designated [examined].

Rhinosia striolella Turati, 1924: 166, pl. 6, fig. 11. LECTOTYPE ♂, LIBYA (BMNH), here designated [examined]. **Syn. n.**

♂, 6.5–8.5 mm. ♀, 6.5–8.0 mm. Head cream to moderately light brown. Labial palpus cream frequently tinged with brown ventrally. Thorax and tegula as head. Fore wing (Fig. 11) with alternating transverse indistinct zig-zag patches of cream and ochre or occasionally deep yellowish brown; darker markings usually narrow. Several very narrow yellowish or brown striations radiating from wing base towards apex. Fore wing markings mostly weakly or moderately, occasionally strongly, contrasting. Hind wing with veins *Rs* and *M*₁, separate as in Fig. 3.

GENITALIA ♂ (Figs 39, 66). Actual margin of tegumen usually coincides with sclerotized margin anteriorly. Saccus moderately slender in apical half; apex wrinkled. Filament slightly helical, slender, extending posteriorly well beyond valva, and very far beyond tegumen anteriorly. Hind edge of vinculum with V-shaped emargination of sclerotization. Saccus moderately broad, apex truncate or very slightly emarginate; short, not quite reaching anterior of tegumen. Aedeagus approximately same length as tegumen plus uncus; basal half very slightly swollen, with moderately large apical hook.

GENITALIA ♀ (Figs 90, 107). Abdomen with patchy, broad, median, longitudinal band constricted at anterior margin of sixth sternite. Seventh abdominal sternite with pair of sclerites and membraneous sac at anterior margin. Invagination of membrane between eighth sternite and papillae anales long, narrow, funnel-shaped. Eighth sternite with lateral pair of weakly sclerotized, broad strips. Tergite and rest of sternite very weakly sclerotized. Apophysis anterior length 0.9–1.0 mm (6); apophysis posterior approximately three times length of apophysis anterior. Antrum curved or constricted towards anterior, slightly shorter than or of similar length to apophysis anterior. Antrum with a few minute spines around posterior; anterior sometimes very slightly indented. Ductus bursae shorter than oval or pear-shaped corpus bursae. Signum large, spinose, particularly around edge, strongly curved inwards.

REMARKS. In approximately 7 per cent of the specimens examined the veins *Rs* and *M*₁ are on a short common stalk in one hind wing. The frenulum was examined in five females and consists of three setae. In the male genitalia the sclerotized anterior margin of the vinculum does not coincide with the actual margin of the vinculum, although both are often indistinct. This occurs in a few other *Mirificarma* species but in these one of the margins is much more distinct than the other, whereas in *pallidipulchra* both margins appear equally faint. The constriction of the female abdominal band of this species and *aflavella* is seen to a much less degree in some other species (*montivaga*, *rhodoptera*, *flavella*, *ocellinella* and *fasciata*).

M. pallidipulchra closely resembles *eburnella*, *aflavella* and *flavella* in the fore wing pattern, although its darker markings tend to be narrower, but it is distinguished from these species by the very long filament of the male genitalia and the pair of sclerites with the membraneous sac of the female abdomen. This last character is unique within the genus.

M. pallidipulchra was described from 23 specimens from Algeria: Hamman-es-Salahine, 18.iv, and El Kantara. I have examined 9 ♂, 9 ♀ from El Kantara and designate as lectotype the specimen bearing Walsingham's number 96479. This is referred to as the 'Type ♂' on the specimen label and in the original description. 1 ♂, 1 ♀ of the remaining syntypes which I have not examined are in the NM.

R. striolella was described from 4 ♂ from Libya, all of which I have examined. The specimen I

designate as lectotype, which bears Turati's 'Typus' label, was already labelled 'lectotype' by Sattler.

BIOLOGY. Host-plant unknown. According to Walsingham (1904: 270) the moths are always found among stems and root-crowns of *Teucrium (polium L. ?)* (Labiatae), but it seems very unlikely that this is the host-plant. Moths have been found in March to May and July.

DISTRIBUTION. Algeria, Tunisia, Libya.

A record of this species from Egypt (Rebel, 1914: 268) is a misidentification of *eburnella*.

MATERIAL EXAMINED (including 9 ♂, 6 ♀ genitalia preparations)

Lectotype ♂ (*pallidipulchra*), **Algeria**: [Constantine province,] El Kantara, 5.v.1903 (Walsingham) (genitalia slide no. 22491). Lectotype ♂ (*striolella*), **Libya**: Cyrenaica, Benghazi, 20.iii.1922 (Krüger) (genitalia slide no. 22490).

Algeria: 1 ♀, Oran, Aflou, vii; 1 ♂, 1 ♀, Hassi Bahbah, v (NM); 8 ♂, 9 ♀ (*pallidipulchra* paralectotypes), El Kantara, 24.iv, 4, 5, 11.v.1903 (Walsingham); 1 ♀, Constantine, Khenchela, v ? **Tunisia**: 1 ♀, Tozeur, iv (MNHN); 1 ♀, Hammamet, v (NM). **Libya**: 1 ♂, 4 ♀, Tripolitania, Gharyān ('Garian'), 700 m, iii, iv; 5 ♀, Tripolitania, Tarhūnah, 200 m, iv; 1 ♂, 1 ♀, Tripolitania, Banī Walīd ('Beni Ulid'), 300 m, iv; 5 ♂, 1 ♀, Tripolitania, Al Khums ('Homs'), 10 m, iv; 2 ♂ (*striolella* paralectotypes), Cyrenaica, Benghazi, 18, 20.iii.1922 (Krüger); 1 ♂ (*striolella* paralectotype), Cyrenaica, Benghazi, 'Merg', 9.iv (Krüger).

Mirificarma aflavella (Amsel) stat. n.

(Figs 1, 2, 12, 40, 67, 91, 108)

Rhinosia flavella aflavella Amsel, 1935: 275. LECTOTYPE ♂, ISRAEL (LN), here designated [examined].

♂, 7.5–9.5 mm. ♀, 7.5–9.5 mm. Head moderately light golden-brown. Labial palpus mostly cream dorsally, golden-brown ventrally. Thorax and tegula as head. Fore wing (Fig. 12) with alternating transverse zig-zag patches of light golden-brown and mid brown, weakly contrasting. Hind wing with veins *Rs* and *M*₁ usually on common stalk as in Fig. 4.

GENITALIA ♂ (Figs 40, 67). Actual margin of tegumen slightly less emarginate than sclerotized margin anteriorly. Sacculus moderately broad, apex wrinkled. Filament gently curved; moderately stout in basal half, tapering apically; extending posteriorly short distance beyond valva, and moderately far beyond tegumen anteriorly. Hind edge of vinculum with V-shaped emargination of sclerotization. Saccus moderately broad, narrowing slightly towards rounded apex; short, approximately reaching anterior of tegumen. Aedeagus almost as long as tegumen plus uncus; with moderately large apical hook.

GENITALIA ♀ (Figs 91, 108). Abdomen with diffuse, broad, median, longitudinal band, slightly more distinct at posterior margin of seventh segment, strongly constricted at anterior margin of sixth sternite. Seventh abdominal segment comparatively broad, anterior margin unmodified. Invagination of membrane between eighth sternite and papillae anales long, narrow, funnel-shaped. Eighth sternite with lateral pair of broad sclerotized strips. Tergite and rest of sternite very weakly sclerotized. Apophysis anterior length 0.7–0.9 mm (5); apophysis posterior three times length of apophysis anterior. Antrum curved or constricted anteriorly, of similar length to apophysis anterior; with minute spines posteriorly, extending into median area of sternite. Antrum anterior sometimes very slightly indented. Ductus bursae one-quarter to slightly more than one-third length of elongate pear-shaped corpus bursae. Signum with approximately three or four large spines arising from sclerotized ridge on one side, otherwise smooth.

REMARKS. In approximately 25 per cent of the specimens examined the veins *Rs* and *M*₁ are separate in one or both hind wings. The frenulum consists of three setae (five females examined). In the female genitalia the ductus bursae merges gradually with the corpus bursae and is distinguished only by its paler appearance in stained preparations.

This species resembles *pallidipulchra*, *flavella* and *eburnella* in fore wing pattern. It is particularly close to *flavella* in this respect although the fore wing pattern is slightly less contrasted. *M. aflavella* differs from these three species in the male genitalia, in which the filament extends a short distance beyond the apex of the valva, and in the form of the signum of the female genitalia.

M. aflavella was originally described as a subspecies of *flavella*, with which it is allopatric. However, I consider that the genitalic differences between them are sufficient to separate them

as distinct species; moreover, *aflavella* appears to have even more features in common with *pallidipulchra* than with *flavella*.

M. aflavella was described from a series collected by Amsel in Palestine, 1930: Tabgha, 12.iii; Jordan, Salt, 7.iv, and Waldheim (c. 15 km E. of Haifa), 9.v (Amsel, 1935: 265). I have examined 8 ♂, 4 ♀, from Tabgha, all of which probably belong to the type-series although some lack Amsel's type-labels and are dated 15.iii instead of 12.iii. The specimen I designate as lectotype, which bears Amsel's label 'Typus', was already labelled 'lectotype' by Sattler.

BIOLOGY. Host-plant unknown. Moths have been found from March to May.

DISTRIBUTION. Greece (Ródhos), Turkey, Israel (including Jordan west bank territories).

MATERIAL EXAMINED (including 4 ♂, 5 ♀ genitalia preparations)

Lectotype ♂, **Israel:** ('Palästina'), 10 km N. of Tiberias, En Sheva ('Tabgha'), 12.iii.1930 (*Amsel*) (genitalia slide no. 17, LMP.; LN).

Greece: 1 ♀, Ródhos ('Rhodes'), Miramare [Hotel], iv. **Turkey:** 1 ♀, Gâvur Dağlari ('Amanus'), 'Schechle', v (NM); 1 ♂, Gâvur Dağlari, 'Tarib', v (NM); 3 ♂, 1 ♀, Haleb, Shar Deresy ('Shar Devesy'). **Israel:** 1 ♂, 3 ♀, ('Palestine'), Haifa, iii-v; 3 ♂, 3 ♀ (paralectotypes), ('Palästina'), Tiberias, En Sheva ('Tabgha'), iii.1930 (*Amsel*) (BMNH and LN); 4 ♂, 1 ♀ (paralectotypes?), Tiberias (including 3 ♂, 1 ♀, 'See Genezareth'), En Sheva ('Tabgha'), iii, 15.iii.1930 (*Amsel*) (NM); 2 ♀, Palestine, plains of Jordan.

Mirificarma flavella (Duponchel)

(Figs 1, 2, 13, 41, 42, 68, 92)

Acompsia flavella Duponchel, [1844]: 512, pl. 89, fig. 7. Type(s), FRANCE: Bondy Forest, end of vi (*Bégrand*) [not traced].

Gelechia segetella Zeller, 1847: 847. LECTOTYPE ♂, SICILY (BMNH), here designated [examined]. [Synonymized by Wocke, 1861: 115.]

♂, 7.0–9.0 mm. ♀, 7.5–9.0 mm. Head yellowish. Labial palpus cream to yellowish, sometimes tinged with brown ventrally. Thorax yellowish, occasionally with faint brown median longitudinal stripe; tegula yellow-ochre to golden-brown. Fore wing (Fig. 13) with alternating transverse zig-zag patches of yellowish colour and deep yellow-tinged brown; moderately strongly contrasting. Hind wing with veins *Rs* and *M*₁ separate as in Fig. 3.

GENITALIA ♂ (Figs 41, 42, 68). Actual margin of tegumen variable but usually slightly less emarginate than sclerotized margin anteriorly. Sacculus with rounded, moderately broad apex. Filament moderately stout at base, tapering and slightly curved towards apex; almost reaching apex of valva posteriorly, extending slightly or scarcely beyond tegumen anteriorly. Hind edge of vinculum with median U- or V-shaped emargination of sclerotization. Saccus broad to very broad, sometimes narrower at rounded apex, reaching or extending slightly beyond tegumen anteriorly. Aedeagus same length as tegumen plus uncus or slightly longer; with moderately large apical hook.

GENITALIA ♀ (Fig. 92). Abdomen with at most faint median, longitudinal band. Eighth sternite and tergite very weakly sclerotized; sternite with faint lateral areas of sclerotization. Apophysis anterior length 0.8–1.0 mm (8); apophysis posterior approximately three times length of apophysis anterior. Antrum almost straight, tapering, usually slightly, towards strongly indented anterior; slightly shorter than apophysis anterior; without minute spines. Ductus bursae slightly shorter to longer than oval or round corpus bursae. Signum small to medium-sized; spinose, particularly around edge.

REMARKS. The fore wing pattern varies from predominantly yellowish to predominantly brown. The frenulum consists of three setae (five females examined). The sacculus of the male genitalia tends to be longer than that in *eburnella* or *aflavella*. The saccus is usually relatively broader than in *eburnella* although it is variable in both species.

M. flavella resembles *eburnella*, *aflavella* and *pallidipulchra* in the fore wing pattern, particularly *aflavella*, although the fore wing pattern of *flavella* is usually more contrasted than in *aflavella*. The male genitalia of *flavella* differ from those of *eburnella* by the rounded apex of the sacculus, and from the other two species by the relatively short filament. The female genitalia differ in having a straight antrum together with an indented apex.

M. flavella was described from an unspecified number of specimens from France: Bondy

Forest (near Paris). The type-specimens have not been traced and are not in the MNHN (Viette, pers. comm.).

G. segetella was described from an unspecified number of specimens from Sicily: Siracusa. I have examined 1 ♂, 1 ♀ syntypes and designate as lectotype the male already labelled 'lectotype' by Sattler.

BIOLOGY. Host-plants: Trifolieae: *Trifolium pratense* L. (moth bred by Frey, France). '*T. minus* Rehl. = *procumbens* G.G.' (the identity of this *Trifolium* species is not clear since *minus* is currently a synonym of *T. dubium* Sibthorp and *procumbens* is a synonym of *T. campestre* Schreber). Loteae: *Lotus corniculatus* L.

These host-plants are referred to by Lhomme ([1948–1949]: 653), who states that the larva has been found in May and June. Moths have been collected from April to July.

G. segetella was described from moths collected on the edges of wheatfields and on chrysanthemum-like flowers (Compositae); however, there is no reason to suppose that the latter could be its host-plant.

DISTRIBUTION. France, Corsica, Italy, Sardinia, Sicily, Greece, Crete, Cyprus, Algeria, Tunisia.

Additional records. Spain (Agenjo, 1968: [4]); Belgium (Lhomme, [1948–1949]: 652); Greece: Attiki (Staudinger, 1871: 255).

The following records should probably be referred to *aflavella*. Israel: Jerusalem (Caradja, 1920: 112); 'Palestine'; Turkey ('Kleinasien') (Wocke, 1871: 300); Turkey ('Asia Minor'); Syria (Rebel, 1901: 158; Meess (*in* Spuler, 1910: 344); Meyrick, 1925: 142); Turkey ('Asia Minor') (Rebel, 1903: 332).

A record of the species from Bulgaria: Rilo (Rebel, 1903: 332) is based on a misidentification of *Orophia ferrugella* ([Denis & Schiffermüller]) (Oecophoridae). A record of *flavella* from Yugoslavia: Dalmatia (Rebel, 1903: 332) may also be a misidentification of *O. ferrugella*.

MATERIAL EXAMINED (including 5 ♂, 8 ♀ genitalia preparations)

Lectotype ♂ (*segetella*), **Sicily**: Siracusa, v. (*Zeller*) (genitalia slide no. 7135).

France: 1 ♀, —; 1 ♂, Ille et Vilaine; 1 ♂, Mayenne (MNHN); 1 ♂, Calvados (MNHN); 1 ♀, Sarthe (MNHN); 1 ♂, Essonne (MNHN); 2 ♂, 5 ♀, Paris; 4 ♂, 1 ♀, Alpes-Maritimes; vi, vii. **Corsica**: 7 ♂, vi. **Italy**: 3 ♂, 3 ♀, Toscana, vi, vii. **Sardinia**: 1 ♀, vi? (NM). **Sicily**: 1 ♀ (*segetella* paralectotype), Siracusa, v. **Crete**: 2 ♀, v, vi (NM). **Cyprus**: 7 ♂, 8 ♀, iv, v. **Algeria**: 2 ♂, Algiers province (MNHN); 2 ♀, Constantine province, vi. **Tunisia**: 1 ♀. No locality data: 23 ex.

Mirificarma eburnella ([Denis & Schiffermüller]) **comb. n.**

(Figs 1, 2, 14, 43, 69, 93, 109)

Tinea eburnella [Denis & Schiffermüller], 1775: 140. Syntypes, AUSTRIA: Wien area (lost). NEOTYPE ♂, AUSTRIA (NM), here designated [examined].

Tinea formosella Hübner, 1796: 62, pl. 23, fig. 160. Syntypes, SWITZERLAND: Genf ('Genève') [not traced].

[Junior primary homonym of *Tinea formosella* [Denis & Schiffermüller], 1775: 140 (Oecophoridae).]

Carcina flammella Hübner, [1825]: 410. [Objective replacement name for *Tinea formosella* Hübner.]

[Synonymized by Zeller, 1847: 848.]

Gelechia rufesformosella Bruand d'Uzelle, 1859: 652. [Objective replacement name for *Tinea formosella*

Hübner.]

[*Rhinosia palidipulchra* Walsingham; Rebel, 1914: 268. Incorrect subsequent spelling of *pallidipulchra*

Walsingham. Misidentification.]

Mirificarma formosella (Hübner) Căpușe, 1964: 17, figs 7, 8.

♂, 5.0–7.5 mm. ♀, 5.5–7.5 mm. Head cream. Labial palpus cream, frequently tinged with brown ventrally. Thorax cream with faint, narrow, median, longitudinal, yellow-ochre stripe; tegula yellow-ochre. Fore wing (Fig. 14) with alternating transverse zig-zag patches of cream and yellowish to ochre, strongly contrasting. A few very narrow ochre striations radiating from wing base towards apex. Hind wing with veins *Rs* and *M*₁ separate as in Fig. 3.

GENITALIA ♂ (Figs 43, 69). Actual margin of tegumen considerably less emarginate than sclerotized margin anteriorly. Sacculus with pointed, moderately slender apex. Filament moderately slender, almost straight, almost reaching apex of valva posteriorly, extending short to moderate distance beyond tegumen

anteriorly. Hind edge of vinculum with U- or V-shaped emargination of sclerotization. Saccus broad, slightly narrower at rounded apex, extending short distance beyond tegumen anteriorly. Aedeagus same length as tegumen plus uncus or slightly longer; apical hook usually moderately large.

GENITALIA ♀ (Figs 93, 109). Abdomen with distinct broad, median, longitudinal band, most prominent in seventh segment. Eighth sternite and tergite very weakly sclerotized; sternite with faint lateral areas of sclerotization. Apophysis anterior length 0.6–0.9 mm (10); apophysis posterior three to four times length of apophysis anterior. Antrum almost straight, tapering, usually slightly, towards rounded or scarcely indented anterior; of similar length to apophysis anterior or slightly longer; without minute spines. Ductus bursae usually merging indistinguishably with elongate corpus bursae. Signum extremely small, sometimes apparently absent.

REMARKS. In less than 2 per cent of the specimens examined the veins *Rs* and *M*₁ are on a short common stalk in one or both hind wings. The frenulum consists of three setae (five females examined). In the male genitalia, the uncus and tegumen posterior tend to be narrower than in *flavella*. The corpus bursae of the female genitalia is extremely flimsy and sometimes very small.

M. eburnella closely resembles *flavella*, *aflavella* and *pallidipulchra* in the wing pattern, although it is usually slightly more contrasted in *eburnella*. It differs from these in the pointed apex of the sacculus together with the relatively short filament of the male genitalia, and the straight antrum without an indented apex in the female genitalia.

M. eburnella was described from an unspecified number of specimens. Zeller (1847: 848) refers to two specimens of this species in the Schiffermüller collection, which is now lost. I designate a male neotype from the type-locality, Austria: Wien area.

BIOLOGY. Host-plants: Trifolieae: *Medicago sativa* L., *M. lupulina* L. (Lhomme, [1948–1949]: 652); *M. polymorpha* L. (Bur clover), *Trifolium repens* L. (variety – Ladino clover), *T. hirtum* Hall (Rose clover); Viciae: *Vicia americana* Muhlenberg (Purple vetch) (California Department of Agriculture unpublished report); Coronilleae: *Hippocrepis comosa* L. (Lhomme, [1948–1949]: 652).

The records of the California Department of Agriculture refer to the species in U.S.A.; the other records are European. I have seen a Walsingham specimen bred from '*Trifolium*'; however, this name has been used broadly and may refer to *Medicago*. A record of the species on *Populus* (Salicaceae) (Hofmann, 1875: 118) is erroneous since it is based on a misidentification of the moth which was probably *Schiffermuelleria formosella* [Denis & Schiffermüller] (Chrétien in Lhomme, [1948–1949]: 652).

The larva has been found in April and May, both in Europe (Lhomme, [1948–1949]: 652) and in U.S.A. (California Department of Agriculture unpublished report). This species has caused severe damage to clover in California, U.S.A., where the larva 'semiskeletonizes' leaves and lightly spins two leaves together, pupating inside the folded leaves (Anonymous, 1969: 69).

Moths have been collected from March to July (also in August according to Piskunov, 1981: 674); in May and June in U.S.A. Hartig (1964: 51) states that there are two generations in Italy, with the moths in June and August.

DISTRIBUTION. *M. eburnella* occurs in western, central and southern Europe south of c. 50° N. and extends to North Africa, the Middle East and U.S.S.R.: Armeniya. It is also found in U.S.A.: California where it is presumed to have been introduced.

According to the literature it has also been found in the following countries. Portugal (Zerkowitz, 1946: 132); Belgium (Lhomme, [1948–1949]: 652); Netherlands (Lempke, 1976: 27); Sardinia (Hartig & Amsel, 1951: 86); Poland (Schille, 1931: 199); Czechoslovakia (Hrubý, 1964: 293); Bulgaria (Rebel, 1903: 332); Crete (specimen in NM, Sattler, pers. comm.); U.S.S.R.: European part (Piskunov, 1981: 674).

MATERIAL EXAMINED (including 7 ♂, 10 ♀ genitalia preparations)

Neotype ♂ (*eburnella*), Austria: Nieder-Österreich ('Austr. inf.'), [near Wien.] Klosterneuburg, 2.vi.1918 ('Freiberg') genitalia slide no. 11230; NM).

Spain: 6 ♂, Granada; 1 ♂, Mallorca; iv–vi. France: 1 ♂, 1 ♀, Sarthe (MNHN); 1 ♂, SW.; vii. Germany: 3 ♂. Switzerland: 2 ♂, 3 ♀, Valais. Corsica: 19 ♂, 7 ♀, v–vii. Italy: 2 ♂, 1 ♀, Toscana; 1 ♂, Lazio; 1 ♂, Campania; iv–vi. Sicily: 5 ♂, 4 ♀, 5 ex., iii–v. Austria: 1 ♂, 2 ♀, —; 1 ♂, Wien area (NM); vi. Yugoslavia:

1 ♂, 1 ♀, Slovenia; 3 ♂, 1 ♀, Croatia; 1 ♂, 1 ♀, Dalmatia; 2 ♂, Bosna i Hercegovina; vi, vii. **Hungary:** 4 ♂, —. **Rumania:** 6 ♂, Timiș, vi (BMNH; NM); 1 ♂, Caras-Severin, vi? (NM). **Albania:** 2 ♂, vii. **Greece:** 1 ♀, Levkás, vi (NM); 1 ♂, Lakonia, iv (ZM); 1 ♂, 1 ♀, Ródhos I., iv. **Cyprus:** 4 ♂, 3 ♀, 1 ex., iv, v. **Turkey:** 1 ♀, Bursa (NM); 1 ♂, Toros Dağlari. **Malta:** 1 ♂, 1 ♀, iv. **Morocco:** 2 ♂, 1 ♀, iv, v. **Algeria:** 7 ♂, 3 ♀, Oran province; 2 ♀, Algiers province (BMNH; MNHN); 13 ♂, 6 ♀, Constantine province; v, vi. **Tunisia:** 3 ♂, 3 ♀, iv, v. **Egypt:** 2 ♂, —; 1 ♀, Cairo area, iv (NM) (Rebel, 1914: 268, as *Rhinosia palidipulchra* Walsingham). **Israel** [including Jordan west bank territories]: 4 ♂, 5 ♀, 'Palestine'; iv, v. **Lebanon:** 4 ♂, v. **Syria:** 2 ♀, N.; 2 ♂, 2 ♀, NW. **U.S.S.R.:** 1 ♀, Armeniya, vii (NM). **U.S.A.:** 6 ♂, 4 ♀, California, v, vi. No locality data: 37 ex.

The *interruptella*-group

♂, ♀. Fore wing without zig-zag pattern of yellowish markings; sometimes with median longitudinal stripe. Hind wing with veins *Rs* and *M*₁ on common stalk as in Fig. 4.

GENITALIA ♂. Uncus usually small or constricted at base; occasionally large. Gnathos a large or small simple hook or modified in shape. Tegumen without pair of lateral processes. Filament-supporting sclerites not crossed or spiralled round each other. Hind edge of vinculum a narrow projection or with distinctly demarcated, usually narrow, median projection. Vinculum with pair of sclerites or single sclerite extending from saccus and approaching hind edge of vinculum.

GENITALIA ♀. One invagination of membrane between eighth segment and papillae anales present, comparatively sturdy, usually between tergite and papillae anales (between sternite and papillae anales in *interruptella*). Eighth segment usually moderately to strongly sclerotized. Apophysis anterior rod-like or very short, broad lobe; usually short. Signum, if present, with many small spines or without spines.

REMARKS. In some species occasional specimens have the veins *Rs* and *M*₁ separate in one or both hind wings. In *mulinella* the lateral edge of the male tegumen is sometimes wavy, producing slight projections but not the distinct rounded processes of the *maculatella*-group. The sclerotization of the female eighth segment is limited to small areas in *fasciata* and, particularly, *ocellinella*; the degree of sclerotization is greater in *lentiginosella* and *cytisella* but still slightly less than in the rest of the *interruptella*-group. The species in this group are more diverse in genitalia structure than those of the *maculatella*-group.

BIOLOGY. Host-plants: Genisteae (*cytisella* also on Trifoliae: *Ononis*).

Mirificarma ocellinella (Chrétien) comb. n.

(Figs 1, 2, 15, 16, 46, 71, 83, 94, 95)

Gelechia ocellinella Chrétien, 1915: 317. LECTOTYPE ♀, TUNISIA (MNHN), here designated [examined].

Gelechia aurantiella Chrétien, 1915: 317. LECTOTYPE ♀, TUNISIA (MNHN), here designated [examined]. **Syn. n.**

Gelechia retamaefoliella Dumont, 1931: 148. LECTOTYPE ♀, TUNISIA (MNHN), here designated [examined]. **Syn. n.**

♂, 9.0–11.0 mm. ♀, 8.5–10.5 mm. Head cream to light brown. Labial palpus cream mottled with brown, sometimes dark brown, particularly on outer surface; second segment with slight to moderate brush below. Thorax and tegula cream to mid brown; tegula sometimes darker at base. Fore wing (Figs 15, 16) cream to light brown, sometimes mottled with darker brown; usually with narrow longitudinal dark brown stripes radiating to apical wing margin. Median stripe sometimes overlaid with broader median longitudinal band, occasionally very dark. Tiny spot sometimes present at one-third to half, on costal edge of cell, and occasionally at or near end of cell.

GENITALIA ♂ (Figs 46, 71). Uncus large, two-thirds to nearly three-quarters width of tegumen. Gnathos basal half increasingly very broad then narrowing sharply to hook-shaped apical half. Actual margin of tegumen slightly less emarginate than sclerotized margin anteriorly. Sacculus very slightly S-curved, usually moderately slender, apex slightly wrinkled and with small irregular projections. Filament very moderately stout, almost straight; extending beyond apex of valva posteriorly, and very far beyond tegumen anteriorly. Tiny tube projecting from opening near filament apex. Hind edge of vinculum with sharply rectangular weakly sclerotized, scarcely emarginate, median projection. Vinculum short, with pair

of almost parallel sclerites. Saccus parallel-sided, moderately slender, apex not or scarcely wider than base; extremely long but not reaching anterior of filament. Aedeagus slightly less than twice length of tegumen plus uncus; apex with very narrow, distinctly sclerotized, slightly projecting structure.

GENITALIA ♀ (Figs 94, 95). Abdomen with at most faint median longitudinal band, scarcely more distinct at posterior margin of seventh segment. Invagination of membrane between eighth tergite and papillae anales funnel-shaped. Eighth sternite with lateral pair of relatively narrow longitudinal sclerotized strips; tergite and rest of sternite weakly sclerotized and faintly wrinkled longitudinally. Unsclerotized median area of sternite at least as wide as each sclerotized area. Apophyses anteriores parallel, rod-like, length 1.0–1.3 mm (7); apophysis posterior three to four times length of apophysis anterior. Pair of membranous sacs from sternite between apophyses anteriores and antrum, densely covered in minute spines. Antrum gently coiled, anterior not indented; extremely long, coiled length approximately twice length of apophysis anterior. Ductus bursae less than half length of oval or round corpus bursae. Signum strongly curved inwards, elongate-oval, distinctly covered with tiny spinules; with spiny-edged plate, usually medially indented, projecting obliquely inside bursa.

REMARKS. The fore wing pattern of *ocellinella* varies by degrees from strongly contrasted markings to the comparatively uniform fore wing of the type-specimens of *retamaefoliella*, which lacks stripes. The frenulum of six out of seven females examined consists of three setae; in the remaining female it consists of two setae. In the male genitalia the tiny tube near the apex of the filament was not visible in two specimens; however, it is easily lost during the preparation of the genitalia. The specimens examined show a wide but gradual range both in wing length and in the female sternite sclerotization. The lectotype of *G. retamaefoliella* is the smallest specimen of *ocellinella* and has the shortest strips of sternite sclerotization. The signum of this specimen is more elongated than others examined and the projection of the signum has no median indentation.

M. ocellinella is the largest species of the genus. It closely resembles *fasciata* in the male and female genitalia, but differs in the shape of the male gnathos and saccus, and to a less extent in the female sternite sclerotization and signum.

M. ocellinella was described from an unspecified number of specimens from Tunisia. I designate the single type-specimen I have examined as the lectotype. The collector is likely to have been Chrétien but may have been Oberthür or Lucas (Chrétien, 1915: 289).

G. aurantiella was also described from an unspecified number of specimens from Tunisia. I have examined a single specimen labelled 'TYPE' [by Viette], '*Gelechia aurantiella*'. It bears the locality label 'Mansour', not 'Gafsa' as cited in the original description; however, there is a locality of this name near Gafsa. Despite this discrepancy, I consider it to be a type-specimen and designate it as the lectotype.

G. retamaefoliella was described from a pair of specimens from Tunisia, both of which I have examined. They are labelled 'Coll. D. Lucas, 1952' and in Lucas's handwriting: '*Gelechia retamaefoliella* Dumont' on the female and '*Gelechia acupediella* Frey' on the male. The specimens are conspecific and the label on the male is incorrect. According to Dr P. Viette (pers. comm.) the type-specimens, which are in the MNHN, belong to the Dumont Collection, not the Lucas Collection, and Lucas may have replaced their original labels. I designate the female as the lectotype.

The type-specimens of *retamaefoliella* represent the small, poorly-marked form of *ocellinella*.

BIOLOGY. Host-plant: Genisteae: *Retama raetam* (Forskål) Webb & Berthelot (*R. 'retem* Webb') (type-series of *G. retamaefoliella*). The larva remains in a long silk tube at the base of the food-plant during the day and comes out to feed on the leafy branches at night (Dumont, 1931: 149). It is fully grown at the beginning of March and the adults Dumont reared emerged in September and October. Moths have been found in January, March to May and September to November. A few females have been collected at light.

DISTRIBUTION. Morocco, Algeria, Tunisia, Libya, Jordan.

MATERIAL EXAMINED (including 7 ♂, 7 ♀ genitalia preparations)

Lectotype ♀ (*ocellinella*), Tunisia: Tozeur, 31.x.1904 (genitalia slide no. 28, LMP.; MNHN). Lectotype

♀ (*aurantiella*), **Tunisia**: [Gafsa], Mansour, 11.xi.1908 (genitalia slide no. 29, LMP; MNHN). Lectotype ♀ (*retamaefoliella*), **Tunisia**: Metlaoui, larva on *Retama* 'retem Webb', moth emerged 9.x.1921 (*Dumonti*) (genitalia slide no. 39, LMP; MNHN).

Morocco: 1 ♂, Agadir, 'Rocksir', xi (NM). **Algeria**: 1 ♂, S. Oran, Aflou region, x; 3 ♂, Lambèse, x. **Tunisia**: 1 ♂ (*retamaefoliella* paralectotype), Metlaoui, on *Retama* 'retem Webb' (MNHN); 1 ♀, Kasserine to Thélepte road, iv (MNHN); 1 ♂, 1 ♀, 1 ex., Bū Hadmah ('Bou Hedma'), iii, x, (MNHN); 6 ♂, 4 ♀, Maknassy, x, xi (MNHN). **Libya**: 1 ♀, W. ('occ.') Sirtica, Sawfajjin ('Sofeggin'), v; 1 ♂, W. ('occ.') Sirtica, Al Qaddāḥiyah ('Gheddahia'), ix. **Jordan**: 1 ♀, Jordan Valley, Zarqa ('Zerqa') R. Colony, c. 100 m below sea level, i.

Mirificarma fasciata sp. n.

(Figs 1, 2, 17, 47, 70, 96)

♂, ♀, 8.5 mm. Head white mottled with grey. Labial palpus white mottled with grey; mainly grey on outer surface. Thorax mottled grey and white; tegula grey. Fore wing (Fig. 17) white and ochreous cream, mottled with dark brown scales mainly near wing margins; very faintly and diffusely forming longitudinal narrow stripes radiating from base towards apex. Brown median longitudinal band, very dark brown on costal side. Very narrow, broken, dark brown stripe along fold to dorsal margin.

GENITALIA ♂ (Figs 47, 70). Uncus large, approximately two-thirds width of tegumen. Gnathos long and only slightly curved; basal half unmodified, extreme apex a very slight hook-shape. Actual margin of tegumen slightly less emarginate than sclerotized margin anteriorly. Saccus straight, slender; extreme apex with small irregular projection. Filament straight, very moderately stout; reaching apex of valva posteriorly, extending far beyond tegumen anteriorly. Hind edge of vinculum with sharply rectangular, weakly sclerotized, scarcely emarginate median projection. Vinculum short, with pair of parallel sclerites. Saccus slender, parallel-sided except apex which is twice width of base; extremely long, extending beyond filament anteriorly. Aedeagus slightly less than twice length of tegumen plus uncus; apex with very narrow, distinctly sclerotized, slightly projecting structure.

GENITALIA ♀ (Fig. 96). Posterior margin of seventh abdominal segment with area of weak dorsal sclerotization and pair of faint ventral patches merging with extremely faint median longitudinal band. Invagination of membrane between eighth tergite and papillae anales conical. Eighth sternite with lateral pair of broad longitudinal sclerotized strips; tergite and rest of sternite weakly sclerotized and very slightly wrinkled longitudinally. Less sclerotized median area of sternite narrower than each sclerotized area. Apophyses anteriores parallel, rod-like, length 0.7 mm (1); apophysis posterior twice length of apophysis anterior. Small pair of membranous sacs from sternite between apophyses anteriores and antrum, densely covered in minute spines. Antrum coiled; anterior not indented; extremely long, actual length approximately three to four times length of apophysis anterior. Ductus bursae less than half length of oval corpus bursae. Signum moderately elongate-oval, with irregular surround and small inwards projection which is medially indented; covered with tiny spinules.

REMARKS. The frenulum of the single female examined consists of two setae on one wing and three on the other. The longitudinal fore wing stripe of this species gives it a superficial resemblance to *interuptella* although the stripe is more diffuse than in the latter. However, it differs considerably in the genitalia, particularly in the shape of the male filament, saccus and sacculus, and in the female apophysis anterior and antrum. *M. fasciata* is also similar externally to specimens of *ocellinella* with a fore wing stripe and the two species appear to be closely related. It differs from *ocellinella* in the shape of the male gnathos and saccus and in the female, to a lesser degree, in the sternite sclerotization and the signum shape.

BIOLOGY. Host-plant unknown. Moths have been found in December.

DISTRIBUTION. Spain.

MATERIAL EXAMINED (including 1 ♂, 1 ♀ genitalia preparations)

Holotype ♂, **Spain**: [Malaga,] San Pedro de Alcántara, xii.1972 (*Ffennell*) (genitalia slide no. 22083).

Paratype. 1 ♀, same data as holotype.

Mirificarma lentiginosella (Zeller)

(Figs 1, 2, 18, 44, 72, 97)

[*Haemylis obscurella* Hübner; Treitschke, 1832: 240–241 (larva only). Misidentification.]*Gelechia lentiginosella* Zeller, 1839: 198; Stainton, 1865: 64, pl. 2, fig. 3. LECTOTYPE ♀, GERMANY (EAST) (BMNH), here designated [examined].

♂, 6.5–8.5 mm. ♀, 6.0–8.0 mm. Head mid to dark brown. Labial palpus dark brown with scattered cream scales; paler on dorsal or inner surface and at segment apices. Thorax and tegula mid to dark brown. Fore wing (Fig. 18) dark brown with scattered pinkish buff scales; small pinkish spot at costa, at two-thirds to three-quarters, sometimes extended to basal margin. Very small darker brown spots with ochreous surround; one in fold, one in cell, both approximately at one-third; one at end of cell. All spots indistinct.

GENITALIA ♂ (Figs 44, 72). Uncus large, slightly constricted at base, at this point half to two-thirds width of tegumen, otherwise slightly narrower than tegumen. Gnathos a large simple hook. Actual margin of tegumen slightly less emarginate than sclerotized margin anteriorly. Sacculus moderately curved inwards, with evenly rounded apex; slender. Filament almost straight basally, without median lobe, with strong kink at apex, very moderately stout; extending posteriorly to hind edge of vinculum or slightly beyond; extending well beyond tegumen anteriorly. Hind edge of vinculum with low, weakly sclerotized median projection not emarginate ventrally. Vinculum with pair of sclerites, parallel or converging and undulating from saccus, almost reaching hind edge of vinculum. Saccus parallel-sided or broader at rounded apex, very long, extending far beyond tegumen anteriorly. Aedeagus approximately 1.5 times length of tegumen plus uncus, with moderately small apical projection.

GENITALIA ♀ (Fig. 97). Abdomen with at most faint, patchy, median longitudinal band scarcely more distinct at posterior margin of seventh segment. Invagination of membrane between eighth tergite and papillae anales long and narrow. Eighth segment not usually strongly sclerotized. Sternite with lateral pair of very broad, longitudinal sclerotized areas; median area of sternite less sclerotized, usually slightly, and narrower than each lateral area of sternite. Tergite with medially expanded sclerotized area at anterior and pair of tiny lateral patches at posterior. Apophyses anteriores diverging, rod-like, length 0.4–0.5 mm (8); apophysis posterior four to five times length of apophysis anterior; without sacs between apophyses anteriores and antrum. Antrum gently coiled or strongly curved, anterior not indented; extremely long, coiled extent two to four times length of apophysis anterior. Ductus bursae usually not more than half length of round corpus bursae. Signum small, oval, weakly sclerotized, slightly curved inwards, covered with tiny spinules.

REMARKS. In six females examined, the frenulum consists of three setae, except for one female in which it consists of four on one wing.

M. lentiginosella differs in the fore wing pattern of very small indistinct spots on a dark background, although this is very occasionally approached by extremely dark specimens of the externally variable *mulinella*. *M. lentiginosella* can be distinguished by the shape of the male filament, which is straight basally, kinked apically and without a lobe, and by the very long antrum together with the diverging apophyses anteriores in the female. This species appears to be close to *constricta* with which it has some common features of the uncus, filament and sacculus. However, the uncus and filament shape are similar in *interuptella*, although to a lesser degree.

M. lentiginosella was described from a series of 25 specimens of which I designate as lectotype the single specimen I have examined, which was already labelled 'lectotype' by Sattler. The type-locality is neither stated in the original description nor on the lectotype label. The original description attributes the species name to Tischer, and I have seen a record, in Tischer's handwriting, of the species collected in Dresden (East Germany). It seems most likely that the specimens from Dresden referred to in Tischer's record were sent to Zeller and that Zeller based his description on these.

BIOLOGY. Host-plants: Genisteae: *Genista tinctoria* L. (larvae and moths bred by Banks and Ford, Great Britain; Stainton, 1865: 64); *G. anglica* L. (moths bred by Nielsen, Denmark; Sorhagen, 1886: 186); *G. germanica* L., *G. sagittalis* L. (Sorhagen, 1886: 186); *Laburnum anagyroides* Medicus (= *Cytisus laburnum* L.) (Müller-Rutz, 1913–1914: 485).

Records of *Centaurium erythraea erythraea* Rafn (= *Erythraea centaurium* Persoon) (Gen-

tianaceae) (Lhomme, [1946–1948]: 607, 'according to certain authors') and *Salix repens* L. ? (Salicaceae) (Sorhagen, 1886: 187) are extremely dubious as host-plants of this species. Sorhagen attributes his record to Hartm[ann] but I have not been able to trace the reference.

The larva occurs in May and June, spinning together the young terminal shoots of the plant; it pupates in a cocoon amongst leaves on the ground (Stainton, 1865: 64), from June to July (Bradford, [1979]: 123). Moths have been collected from June to August (also in May according to Mariani, 1943: 167).

DISTRIBUTION. Great Britain, France, Denmark, Central Europe, Italy, Rumania.

Additional records. Spain (Agenjo, 1968: [4]); Netherlands (Lempke, 1976: 26); Sweden (Krogerus *et alii*, 1971: 21); Poland (Schille, 1931: 176); Czechoslovakia (Nickerl, 1908: 20); Yugoslavia (Mariani, 1943: 167); Hungary (Gozmány, 1958: 227); Turkey (Klimesch, 1961: 648); U.S.S.R.: European part (Piskunov, 1981: 672); U.S.S.R.: Armeniya (Rebel, 1901: 14).

MATERIAL EXAMINED (including 8 ♂, 8 ♀ genitalia preparations)

Lectotype ♀, [Germany (East): Dresden], larva on *Genista tinctoria*, ex viii (genitalia slide no. 22492).

Great Britain (England): 67 ex., —; 2 ex., Worcester: 15 ♂, 13 ♀, 3 ex., Dorset: 1 ex., New Forest; 12 ex., Isle of Wight; 52 ex., Sussex; 8 ex., Kent; 7 ex., Essex; vii–viii. **France:** 1 ♂, Basses Alpes; 1 ♀, Alpes-Maritimes, viii. **Denmark:** 3 ♂, 1 ♀, Jylland, vi (BMNH; ZM). **Germany (West):** 4 ♂, 1 ♀, Niedersachsen; 1 ♂, Bayern, viii. **Germany (East):** 6 ♂, 3 ♀, 1 ex., Gera. **Switzerland:** 1 ♂, Zurich. **Italy:** 1 ♀, Toscana, viii. **Austria:** 2 ♂, 1 ♀, Wien, viii (NM). **Rumania:** 1 ♂, 1 ♀, Cluj, viii (MINGA). No locality data: 34 ex.

Mirificarma constricta sp. n.

(Figs 1, 2, 19, 45, 73)

♂, 5.5–6.0 mm. Head mid brown. Labial palpus mottled cream and brown. Thorax and tegula mid brown. Fore wing (Fig. 19) mottled mid brown, slightly darker at base. Dark brown spot across fold at one-third extending to dorsal margin. Small dark brown spot at end of cell.

GENITALIA ♂ (Figs 45, 73). Uncus small, slightly more than half width of tegumen, strongly constricted at base. Gnathos large, only moderately curved; extreme apex a very slight hook-shape. Actual margin of tegumen slightly less emarginate than sclerotized margin anteriorly; sclerotized margin X-shaped medially. Saccus moderately S-curved; with evenly pointed apex, moderately slender. Filament basal half straight, very broad dorsoventrally and compressed laterally; median lobe projecting ventrally; apical half more slender, kinked; extending beyond hind edge of vinculum posteriorly, and moderately beyond tegumen anteriorly. Median projection of hind edge of vinculum with ventral V-shaped emargination; dorsally deeply U-emarginate. Vinculum with pair of sclerites converging from saccus, almost reaching hind edge of vinculum. Saccus moderately broad, parallel-sided or slightly bow-sided, with rounded apex; extending slightly beyond tegumen anteriorly. Aedeagus same length as tegumen plus uncus or slightly shorter; projection near apex slight.

GENITALIA ♀. Unknown.

REMARKS. *M. constricta* is very similar in fore wing pattern to *cabezella* and, to a less extent, *scissella* and *rhodoptera* but differs in the constricted uncus and the shape of the filament. *M. constricta* resembles *lentiginosella* in these male genitalic characters; however, the single known female of *constricta* lacks the abdomen and it is impossible to be certain of its relationships.

BIOLOGY. Host-plant unknown. Moths have been found in August and October.

DISTRIBUTION. Northern Morocco.

MATERIAL EXAMINED (including 2 ♂ genitalia preparations)

Holotype ♂, **Morocco:** Tanger, 45 m, 30.x.1934 (*Querci*) (genitalia slide no. 7477).

Paratypes. **Morocco:** 1 ♂, 1 ♀, Tanger, 45 m, 30.viii, 24.x.1934 (*Querci*).

Mirificarma cytisella (Treitschke)

(Figs 1, 2, 5, 20, 21, 48, 74, 75, 98, 110)

Lita cytisella Treitschke, 1833: 99.

♂, 6.0–8.0 mm. ♀, 6.0–7.5 mm. Head white to cream, eye socket edged with dark brown anteriorly. Labial palpus white to cream, with dark brown predominantly on outer surface of first segment and outer, basal two-thirds of second segment. Thorax and tegula white to cream with scattered brown scales. Fore wing (Figs 20, 21) white to cream, mottled, sometimes sparsely, with brown scales, usually slightly darker in apical fifth. Costa darker at base. Indistinct, narrow, transverse cream streak basal to apical fifth. Brown wedge-shaped spot, usually dark, across fold at one-third extending to dorsal margin. Smaller dark brown spot, sometimes bisected, at end of cell. Dark spots often with narrow ochreous surround.

GENITALIA ♂ (Figs 48, 74, 75). Uncus small, narrowing progressively from tegumen, with tiny, pointed median projection at apex. Gnathos small, hook-shaped, with median spine on anterior surface. Actual margin of tegumen coincides with or slightly less emarginate than sclerotized margin anteriorly. Sacculus very small, hook-shaped. Filament slightly, sometimes irregularly, curved; moderately slender, gradually broader at base; almost reaching hind edge of vinculum or extending moderately short distance beyond, posteriorly; extending short distance beyond tegumen anteriorly. Hind edge of vinculum projecting slightly, medially; projection with truncate or irregular apex ventrally, slightly emarginate dorsally. Vinculum with pair of sclerites parallel or slightly diverging from saccus. Saccus almost parallel-sided, usually with truncate apex; almost reaching anterior of tegumen. Aedeagus of similar length to tegumen plus uncus; projection near apex small.

GENITALIA ♀ (Figs 98, 110). Posterior margin of seventh abdominal tergite with well-defined crescent of sclerotization. Invagination of membrane between eighth tergite and papillae anales funnel-shaped. Eighth sternite sclerotized laterally; median area with sclerotization often weaker and patchy. Tergite very weakly sclerotized. Apophysis anterior rod-like, length 0.4 mm (7); apophysis posterior approximately three times length of apophysis anterior. Antrum extremely short. Ductus bursae usually of similar length to, or slightly longer than, pear-shaped or oval corpus bursae. Signum a narrow, inwards-projecting ridge, with faint surrounding area of sclerotization.

REMARKS. The frenulum of five out of seven females examined consists of two setae; in the remaining two it consists of three setae on one wing and two on the other.

Specimens from Portugal, the extreme west of the range, differ in fore wing pattern from specimens from France eastwards and were described as subspecies *leonella*. Examination of material from intermediate localities, particularly in Spain, is necessary to decide whether subspecific status is justified.

M. cytisella has two forms of male genitalia. In the typical form of *c. cytisella*, the filament extends distinctly beyond the hind edge of the vinculum and is usually gently and evenly curved, or almost straight excluding the base. In other specimens of *cytisella*, including *c. leonella*, the filament scarcely extends beyond the hind edge of the vinculum and is usually more irregularly curved. The spine on the gnathos is usually shorter in the typical form than in the other specimens of *c. cytisella*, which I am referring to as the small form, or in *leonella*. The small form of *c. cytisella*, and *leonella*, have smaller male genitalia than the typical form of *c. cytisella*. In the female genitalia, the signum varies from small to large but without apparent correlation with the two forms of male genitalia. I have assigned the females to each form of *c. cytisella* on the basis of geographic association with the males.

It is possible that the small form of *c. cytisella* could be a separate subspecies from the typical form, and might be more closely allied to *leonella* since the small form and *leonella* are similar in genitalia structure. However, the small form has a widely disjunct distribution, populations occurring both west and east of the typical form, thus it seems unsatisfactory to consider it a distinct subspecies.

The fore wing spots of *cytisella*, other than in *leonella*, are usually more distinct than in the other species of *Mirificarma*, except *maculatella* and *denotata* which have larger spots. *M. cytisella* can be distinguished from the other species of the genus by the small hook-shaped sacculus, the spine of the gnathos, and the form of the signum.

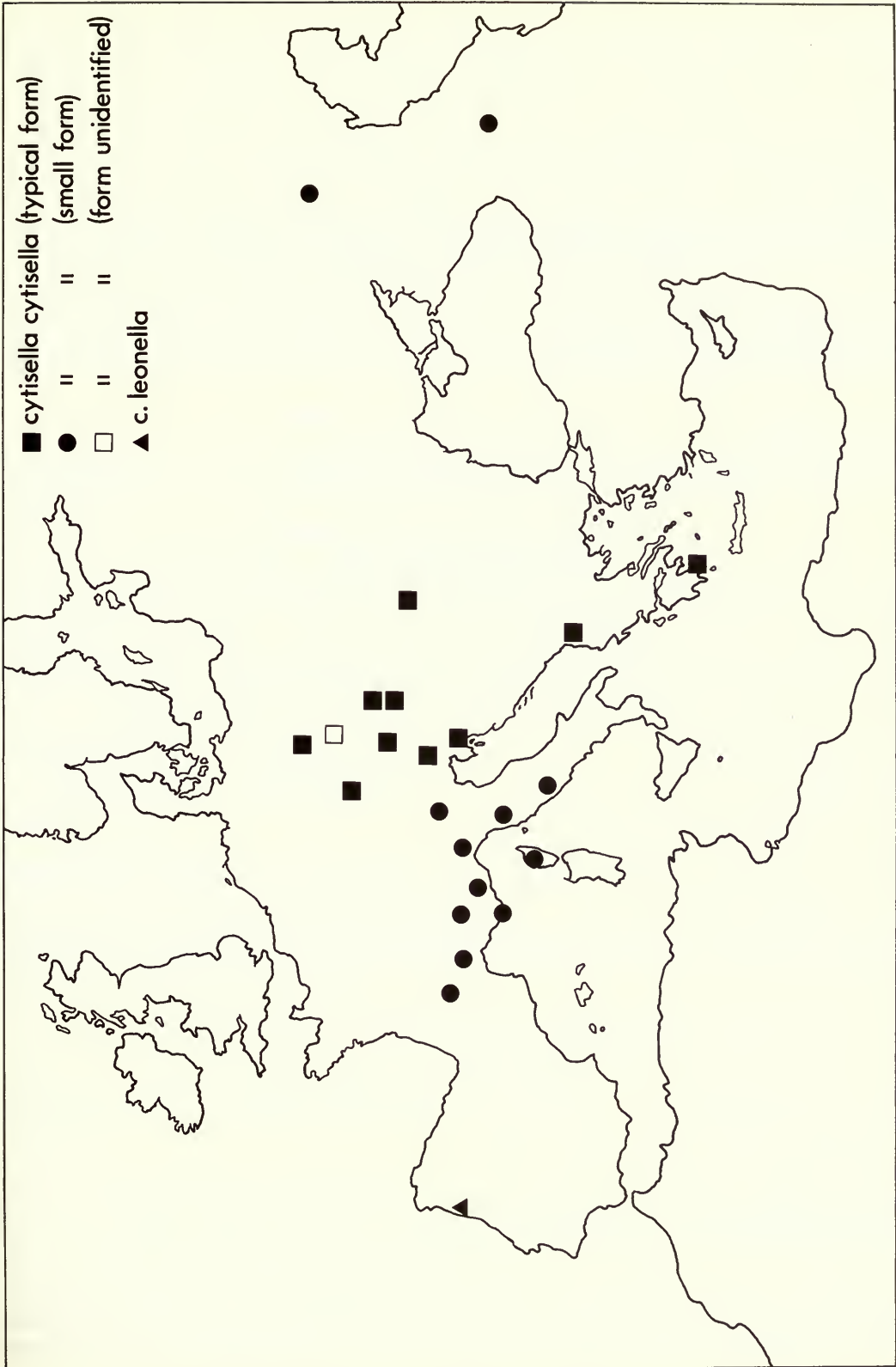

Fig. 5 Distribution map of the subspecies and forms of *Mirificarma cytisella* (Treitschke).

BIOLOGY. Host-plants: Genisteae: *Cytisus nigricans* L. (Treitschke, 1833: 100); *Genista* (Schütze, 1931: 120 attributes this to an untraced record by Disqué); *Laburnum anagyroides* Medicus (= *Cytisus laburnum* L.), *Calicotome spinosa* (L.) Link and Trifolieae: *Ononis spinosa spinosa* L. (= *campestris* Koch & Ziz) (Lhomme, [1946–1948]: 592; the record of *L. anagyroides* is based on the proximity of the moths to the plant and requires the confirmation of bred specimens).

A record of *Daphne* (Thymelaeaceae) (Mariani, 1943: 168) as a host-plant is probably erroneous.

The larva occurs in June, September and October within two or three spun leaves and the pupal stage is from October to April (Treitschke, 1833: 100; Lhomme, [1946–1948]: 592; Eckstein, 1933: 134). Moths have been collected from April to September.

DISTRIBUTION (Fig. 5). France, Germany, Corsica, Italy, Austria, Yugoslavia, Czechoslovakia, Hungary, Albania, Greece, U.S.S.R.

Additional records from the literature: Spain (Agenjo, 1968: [4]); Switzerland (Müller-Rutz, 1914: 489); Poland (Schille, 1931: 179).

Key to the subspecies

- 1 Spot across fold of fore wing dark, strongly contrasting with background *c. cytisella* (p. 36)
 – Spot across fold of fore wing not strongly contrasting with background *c. leonella* (p. 37)

Mirificarma cytisella cytisella (Treitschke)

(Figs 5, 20, 48, 75, 98, 110)

Lita cytisella Treitschke, 1833: 99. LECTOTYPE ♀, GERMANY (EAST) (TM), here designated [examined].
Gelechia cytisella Treitschke ab. *roseella* Hauder, 1918: 102. [Unavailable, infrasubspecific name.]

♂, 6.0–8.0 mm. ♀, 6.0–7.5 mm. Fore wing (Fig. 20) with mottled brown darker at costa in four-fifths. Wedge-shaped spot across fold dark brown, strongly contrasting with background, usually unbroken.

GENITALIA ♂ (Figs 48, 75). Filament almost reaches or extends beyond hind edge of vinculum.

	Typical form	Small form
Tegumen plus uncus length	1.2–1.3 mm (14)	1.0–1.1 mm (10)
Filament length	1.2–1.3 mm (14)	0.8–0.9 mm (10)
Filament length/tegumen plus uncus length	1.0 mm (14)	0.7–0.9 mm (12)

GENITALIA ♀ (Figs 98, 110). As described on p. 34.

REMARKS. The nominate subspecies differs from *c. leonella* in the more strongly contrasting fore wing pattern of the former.

M. c. cytisella was described from an unspecified number of specimens. I designate as lectotype the single type-specimen I have examined, which was already labelled 'lectotype' by Karsholt.

BIOLOGY. Host-plants as described on p. 36. Moths of the typical form have been found from April to August; those of the small form have been found from May to September.

DISTRIBUTION (see Fig. 5). Typical form: Germany, Austria, Yugoslavia, Hungary, Albania, Greece. A pair of specimens from the Meyrick Collection, bearing the data 'France: Ardèche', may have been mislabelled.

Small form: France, Corsica, Italy, U.S.S.R.

Form unidentified: Czechoslovakia.

MATERIAL EXAMINED

Typical form (including 14 ♂, 5 ♀ genitalia preparations)

Lectotype ♀ (*cytisella*), **Germany (East)**: Meissen, highlands, larva on *Cytisus nigricans*, ix, ex iv (von Tischer) (TM).

France: 1 ♂, 1 ♀, Ardèche. **Germany**: 3 ♂, 1 ♀, S. **Germany (West)**: 1 ♀, Regensburg ('Ratisbon'); 2 ♂, Bavaria. **Austria**: 1 ♂, [Kärnten,] Ofen; 2 ♂, 1 ♀, Ober-Österreich, Linz area, iii ?, vii (LN; NM); 2 ♀, Nieder-Österreich, Wiener Wald, Leopoldsberg, vi (NM); 1 ♂, Mödling; 1 ♀, Nieder-Österreich,

Klosterneuburg, iv (NM); 1 ♂, Nieder-Österreich, Falkenstein, vi. **Yugoslavia:** 1 ♂, Rijeka ('Fiume') (NM); 1 ♀, Istra ('Istria'), 'Sin', iv (NM); 2 ♀, Zadar ('Zara'), viii (NM). **Hungary:** 1 ♂, near Debrecen, Ermihalyfalva, v (NM) (Rothschild, 1913: 80). **Albania:** 1 ♂, [NE], Kula Ljums, vi (NM) (Rebel, 1931: 146). **Greece:** 1 ♂, Lakonia, 5 km S. of Monemvasia, iv (ZM).

Small form (including 13 ♂, 4 ♀ genitalia preparations)

France: 1 ♂, Lot, Douelle, vii (MNHN); 1 ♂, Ste Croix-Vallée-Française, vii (MNHN); 1 ♂, Hautes-Alpes, St Julien-en-B[eauchène], vii; 1 ♂, Hyères; 1 ♀, Hyères, v (MNHN); 1 ♂, 1 ♀, Alpes-Maritimes, St Martin, 1500 m, vi. **Corsica:** 3 ♂, 1 ♀, Evisa, 850 m, viii, ix (NM). **Italy:** 1 ♂, Piemonte, 'Valle di Poggio di' Casasco, v; 1 ♀, Piemonte, Monferato, Cardona, v; 1 ♂, Trentino-Alto Adige, Pietramurata, 250 m, viii; 1 ♀, Trentino-Alto Adige, Val Sarca, Pietramurata, 250 m, vii (all coll. Jäckh, Bidingen); 1 ♂, Toscana, Fiesole, vii; 1 ♂, Rome (MNHU). **U.S.S.R.:** 4 ♂, [S. of Volgograd,] Krasnoarmeysk ('Sarepta'), viii; 1 ♂, Bol'shoy Kavkaz ('Caucasus'), Tbilisi ('Tiflis'), v.

Form unidentified (including 1 ♀ genitalia preparation)

France: 1 ♀, Le Rozier, vii (MNHN); 1 ♀, Hérault, 'St Guilhem-le-Dt' (MNHN). **Italy:** 2 ♀, [Friuli Venezia], Raibl (NM). **Czechoslovakia:** 2 ♀, Bohemia; 1 ♀, Praha ('Prag') (MNHU). No locality data: 4 ♂, 6 ♀.

Mirificarma cytisella leonella Amsel

(Figs 5, 21, 74)

Mirificarma [Gelechia] cytisella leonella Amsel, 1959: 156, 164, pl. 1, fig. 3. Holotype ♂, PORTUGAL (LN) [examined].

♂, 6.5–7.5 mm. Fore wing (Fig. 21) with mottled brown slightly darker in four-fifths. Wedge-shaped spot across fold not strongly contrasting with background, usually broken.

GENITALIA ♂ (Fig. 74). Filament does not extend beyond hind edge of vinculum.

Tegumen plus uncus length	0.9–1.0 mm (3)
Filament length	0.7–0.8 mm (3)
Filament length/tegumen plus uncus length	0.8–0.9 mm (3)

GENITALIA ♀. Not examined.

REMARKS. *M. c. leonella* differs from the nominate subspecies in the less strongly contrasting fore wing pattern of the former.

BIOLOGY. Host-plant unknown. Moths have been found in June (also in August according to Amsel, 1959: 157).

DISTRIBUTION. Portugal.

MATERIAL EXAMINED (including 3 ♂ genitalia preparations)

Holotype ♂, Portugal: [40 km N. of Porto,] Singeverga, vi.1953 (*Monteiro*) (only genitalia slide, no. 323c, Sattler, examined; LN) (labelled 'spp. lusitaniella Ams.').

Portugal: 3 ♂ (paratypes), Singeverga, vi.1953 (*Monteiro*) (LN); 1 ♂ (paratype), Montalegre (*Monteiro*) (LN) (only genitalia slide examined).

Mirificarma monticolella (Rebel) comb. n., stat. n.

(Figs 1, 2, 22, 49, 57, 58, 76)

Lita acuminatella f. *monticolella* Rebel, 1931: 147, 160. LECTOTYPE ♂, ALBANIA (NM), here designated [examined].

♂, 6.5–7.0 mm. Head cream. Labial palpus third segment and apex of second segment cream, otherwise mid brown mottled with cream on inner surface. Thorax and tegula cream mottled with brown. Fore wing (Fig. 22) cream mottled with brown, predominantly cream in central area of wing; apex edged with small dark brown spots. Small dark brown spots, sometimes indistinct: spot or streak in fold near base, spot in fold at one-third, two on costal edge of cell and one at end of cell.

GENITALIA ♂ (Figs 49, 57, 58, 76). Uncus small, narrowing progressively from tegumen, without apical projection. Gnathos extremely short, without median spine. Actual margin of tegumen coincides with sclerotized margin anteriorly. Sacculus broad, particularly towards apex, club-shaped. Filament gently

curved, very moderately stout; posteriorly extending to hind edge of vinculum or just beyond, scarcely extending beyond tegumen anteriorly. Hind edge of vinculum projecting medially with broad U-shaped emargination of sclerotization. Vinculum with pair of sclerites. Saccus very slender, wider at base than at pointed apex; not quite reaching anterior of tegumen. Aedeagus almost as long as tegumen plus uncus; projection near apex minute.

GENITALIA ♀. Unknown.

REMARKS. The small dark spots at the apex of the fore wing are also present in many other species but they are particularly distinct in *monticolella* and *interruptella* in which they contrast with the light ground colour. In the male genitalia, the sclerites of the vinculum appear faint, perhaps because the preparations are not stained.

This species bears a superficial resemblance to *montivaga* and some specimens of *ocellinella* which also have a pale fore wing with sparse dark markings. However, *monticolella* is smaller than *ocellinella* and *montivaga* has no fore wing markings other than the mottled ground colour. *M. monticolella* has many genitalic differences from both species, including the size of the male filament. *M. monticolella* can be distinguished from all other *Mirificarma* species by the extremely short gnathos and the very slender, short saccus.

M. monticolella was described from 2 ♂, both of which I have examined.

BIOLOGY. Host-plant unknown. Moths have been found in May or June.

DISTRIBUTION. Northern Albania.

MATERIAL EXAMINED (including 2 ♂ genitalia preparations)

Lectotype ♂, **Albania**: 15 km NNE. of Kula e Lumës, Bështriq ('Pashtriq'), 1896 m, 29.v.–4.vi.1918 (*Penther, Predota & Zerny*) (genitalia slide no. 1491; NM).

Albania: 1 ♂ (paralectotype), same data as lectotype (NM).

Mirificarma interruptella (Hübner)

(Figs 1, 2, 4, 23, 50, 77, 84, 99, 111)

Ph[alae]na Tin[ea] interruptella Hübner, 1793: 14, pl. 88. Type(s) [not traced].

Tinea interruptella Hübner; Hübner, 1822: 72. [Incorrect subsequent spelling of *interruptella* Hübner.]

Anacampsis interrupta Curtis, 1827: no. 189, folio [2]. [Unjustified emendation of *interruptella* Hübner.]

♂, ♀, 7.0–8.5 mm. Head white to cream. Labial palpus with dark apex; second segment with brown areas, particularly externolaterally, sometimes dark, apex cream. Thorax white to cream, occasionally with thin, median, longitudinal dark brown stripe. Tegula dark brown, sometimes with scattered cream scales. Fore wing (Fig. 23) cream tinged with pale yellow; with scattered brown scales. Dark brown, median, longitudinal band present, continuous but usually darker in fold and on costal edge of band from one-third to apex. Fore wing apex distinctly edged with small dark brown spots.

GENITALIA ♂ (Figs 50, 77). Uncus small, half to two-thirds width of tegumen; sometimes slightly constricted at base. Gnathos a large strongly-angled hook, without median spine. Actual margin of tegumen slightly less emarginate than sclerotized margin anteriorly. Saccus long, slender with spatulate apex. Filament helical, very moderately stout; not extending posteriorly far beyond hind edge of vinculum, scarcely extending beyond tegumen anteriorly. Hind edge of vinculum far-projecting, narrowing to median V-shaped emargination. Vinculum with single sclerite. Saccus very slender, slightly deflected to left in ventral view, extending slightly beyond tegumen anteriorly. Aedeagus slightly longer than tegumen plus uncus; apex cylindrical with tiny projection.

GENITALIA ♀ (Figs 99, 111). Posterior margin of seventh abdominal segment with area of well-defined sclerotization on tergite and pair of adjoining patches on sternite. Very slight, flimsy invagination of membrane between eighth sternite and papillae anales. Eighth sternite strongly sclerotized laterally; asymmetrical, with lobe projecting over median area from left side in ventral view; lateral areas distinctly contrasting with membranous median area. Median area of sternite without striations. Tergite consisting of lateral longitudinal strips connected by narrow posterior horizontal strip, all strongly sclerotized; otherwise absent. Apophyses anteriores diverging lobes, length approximately 0.3–0.4 mm (8), left shorter than right in ventral view; apophysis posterior approximately three to four times length of apophysis anterior. Antrum almost straight, sometimes deflected to one side, narrowing towards anterior; anterior not indented; moderately long, extending beyond apophyses anteriores. Ductus bursae of similar length to oval or round corpus bursae. Signum oval, curved inwards, covered with tiny spinules.

REMARKS. The small dark spots at the apex of the fore wing are also present in many other species; as the spots contrast with the light ground colour of the wing in *interruptella*, they are particularly pronounced. The frenulum in five females examined consists of three setae. The genitalia are more asymmetrical than those of other *Mirificarma* species, particularly the male saccus and the eighth sternite and apophyses anteriores of the female.

This species bears a superficial resemblance to *fasciata* and to specimens of *mulinella* in which the fore wing ground colour is pale and the stripe is unbroken, although the dark fore wing stripe of *interruptella* contrasts more strongly with the cream ground colour. *M. interruptella* is clearly distinguished from both species by the form of the male filament, the slender sacculus with a spatulate apex which is unique within the genus, and the apophysis anterior of the female.

M. interruptella appears to have some affinities to *burdonella* and *flavonigrella*, with which it shares the aedeagus apex shape; in the female, the lobe-shaped apophysis anterior and the degree of sclerotization of the eighth sternite resemble those of *burdonella*. *M. interruptella* is distinguished from both species by characters including the sacculus shape and the large gnathos, and from *burdonella* by the presence of the signum. The female of *flavonigrella* is unknown.

Subsequent to Hübner's original description, many authors have misspelt *interruptella* as '*interruptella*' including Koçak (1982: 106) who incorrectly cites '*interruptella* Hübner, 1793' as a junior primary homonym of *interruptella* de Villers (1789: 520) and proposes *albicosta* Haworth as the replacement name. *Coleophora albicosta* Haworth is currently a valid species of Coleophoridae (Bradley, 1966: 132). The identity of *Phalaena (Tinea) interruptella* de Villers is unknown.

BIOLOGY. Host-plants: Genisteae: *Cytisus scoparius* (L.) Link (as *Spartium scoparium*) (Disqué, 1908: 129); *C. purgans* (L.) Boissier, formerly in *Genista* (Lhomme, [1946–1948]: 594); *Genista (tinctoria* L., *pilosa* L., *germanica* L., or *sagittalis* L.) (Disqué, 1908: 79).

The larva probably lives in the flowers (Lhomme, [1946–1948]: 594, attributes this information to Peyerimhoff) although Schütze (1931: 121) records it in August under leaves spun to the twig (on *C. scoparius*). Sorhagen (1886: 187) records the larva in May. Moths have been collected from March to July (also in August according to Sorhagen, 1886: 187).

DISTRIBUTION. Spain, France, central Europe, Czechoslovakia, Poland, North Africa.

Additional records. Portugal (Zerkowitz, 1946: 133); Belgium (Lhomme, [1946–1948]: 594); Netherlands (Lempke, 1976: 26); Italy (Mariani, 1943: 167). Records of *interruptella* from Great Britain are misidentifications of *mulinella* (see p. 43).

MATERIAL EXAMINED (including 11 ♂, 10 ♀ genitalia preparations)

Spain: 1 ♂, Avila (NM); 1 ♂, 1 ♀, Teruel (NM); v–vii; 1 ♂, 1 ♀, Granada (NM). **France:** 2 ♂, 1 ♀, Essonne; 1 ♂, Lot; 2 ♀, Pyrénées-Orientales; 2 ♂, 1 ♀, Basses Alpes; 6 ♂, 11 ♀, Var; iv–vi. **Germany:** 1 ♂, 2 ♀, —; 1 ♂, N. **Germany (West):** 1 ex., Baden-Württemberg; 1 ♀, Niedersachsen, v (coll. Jäckh, Bidingen); 1 ♂, Hamburg, vi (coll. Jäckh, Bidingen). **Germany (East):** 1 ♀, Potsdam, vii (NM). **Switzerland:** 1 ♂ (NM). **Austria:** 1 ♂, 1 ♀, Wien (NM). **Czechoslovakia:** 1 ♀, Plzeň, v ? (NM). **Poland:** 5 ♂, 5 ♀, Szczecin; 1 ♂, Zielona Góra; v, vi ? **Morocco:** 2 ♂, iii. **Algeria:** 1 ♂, 1 ♀, Constantine province, v ? **Tunisia:** 1 ♂, iv. No locality data: 33 ex.

Mirificarma flavonigrella (Chrétien) comb. n.

(Figs 1, 2, 24, 51, 59, 78)

Gelechia flavonigrella Chrétien, 1915: 318. LECTOTYPE ♂, ALGERIA (MNHN), here designated [examined].

♂, 6.0 mm. Head cream. Labial palpus cream, mottled with dark brown mostly confined to outer surface of first and second segments. Thorax cream; tegula dark brown. Fore wing (Fig. 24) mottled light brown and cream, darker in apical fifth; costal margin brown, dark at base; with dark brown stripe along fold separated by pale area from longitudinal, median, more diffuse brown stripe which extends from half to near apex. Faint yellowish tinge scattered on fore wing.

GENITALIA ♂ (Figs 51, 59, 78). Uncus small, narrowing towards apex, approximately half width of tegumen. Gnathos a small simple hook. Actual margin of tegumen coincides with sclerotized margin anteriorly. Sacculus long, extending far beyond median projection of hind edge of vinculum; broad apically, club-shaped, with inner edge slightly rugose towards apex. Filament curved although apical half almost straight; basal half expanded dorsoventrally and compressed laterally, smooth; apical half moderately, uniformly, slender. Filament not reaching hind edge of vinculum posteriorly, extending beyond tegumen anteriorly. Median projection of hind edge of vinculum with shallow V-shaped emargination. Vinculum with pair of sclerites converging near hind edge of vinculum. Saccus moderately broad, parallel-sided with rounded apex, barely extending beyond tegumen. Aedeagus slightly longer than tegumen plus uncus; apex almost cylindrical with minute projection.

GENITALIA ♀. Unknown.

REMARKS. This species bears a very close superficial resemblance to some *mulinella* specimens in which the fore wing has a light background and a broken stripe, but it can be distinguished from *mulinella* by the club-shaped sacculus of the male genitalia. *M. flavonigrella* is very similar to *burdonella* in external appearance and genitalia, and might prove to be no more than a subspecies if further material becomes available. They are allopatric but this may not be significant as both species are known from so little material. *M. flavonigrella* differs from *burdonella* in the fore wing pattern since the two stripes are slightly less widely separated by a pale area. The male genitalia differ from those of *burdonella*, mainly in the sacculus extending far beyond the median projection of the hind edge of the vinculum, and in the shallower emargination of this projection.

M. flavonigrella was described from an unspecified number of specimens of which I designate as lectotype the single type-specimen examined, which was already labelled 'lectotype' by Sattler.

BIOLOGY. Host-plant unknown. The moth has been found in May.

DISTRIBUTION. Algeria (Oran area).

MATERIAL EXAMINED (including 1 ♂ genitalia preparation)

Lectotype ♂, **Algeria**: near Oran, Frenda, v.1911 (genitalia slide no. 471b, Sattler; MNHN).

Mirificarma burdonella (Rebel)

(Figs 1, 2, 25, 52, 79, 100, 112)

Gelechia burdonella Rebel, 1930: 25. LECTOTYPE ♂, CORSICA (NM), here designated [examined].
Gelechia bardonella Rebel; Gaede, 1937: 148. [Incorrect subsequent spelling.]

♂, 5.5–6.5 mm. ♀, 5.5–6.0 mm. Head cream to light brown. Labial palpus cream, mottled with dark brown mostly confined to outer surface of first segment and basal part of second segment; apex dark brown. Thorax cream to light brown, sometimes with scattered brown scales. Tegula usually brown in basal half, pale apically. Fore wing (Fig. 25) mottled light brown and cream, usually darker in apical fifth and at costal margin, with irregular dark brown stripe along fold. This stripe usually well separated by pale area from longitudinal, irregular, dark brown stripe which is median or slightly costad, extending from almost half to three-quarters or near apex, continuous, or, infrequently, broken. Faint longitudinal yellowish streak sometimes present in costal half and fold line.

GENITALIA ♂ (Figs 52, 79). Uncus small, narrowing towards apex, slightly more than half to two-thirds tegumen width. Gnathos a small simple hook. Actual margin of tegumen almost coincides with sclerotized margin anteriorly. Sacculus scarcely extending beyond median projection of hind edge of vinculum; broad, club-shaped, with inner edge slightly rugose. Filament slightly curved although apical half almost straight; basal half expanded dorsoventrally, laterally compressed and wrinkled; apical half moderately, uniformly, slender. Filament not reaching hind edge of vinculum posteriorly, extending a short distance beyond tegumen anteriorly. Median projection of hind edge of vinculum with deep, narrow U- or V-shaped emargination. Vinculum with pair of sclerites converging near hind edge of vinculum. Saccus moderately broad, parallel-sided or narrowing slightly towards rounded apex, extending slightly beyond tegumen anteriorly. Aedeagus slightly longer than tegumen plus uncus, slightly S-shaped; apex almost cylindrical with tiny projection.

GENITALIA ♀ (Figs 100, 112). Posterior margin of seventh abdominal segment with area of well-defined sclerotization on tergite, pair of patches sometimes present on sternite. Invagination of membrane between eighth tergite and papillae anales long and narrow. Eighth sternite strongly sclerotized laterally, wrinkled, distinctly contrasting with weakly sclerotized, horizontally striated median area bordered by pair of narrow longitudinal sclerites. Tergite with pair of very small, lateral, sclerotized areas extending from sternite, otherwise weakly sclerotized. Apophyses anteriores diverging lobes, length 0.2 mm (3); apophysis posterior approximately six times length of apophysis anterior. Antrum slightly curved and constricted towards anterior; anterior not indented; moderately long, approximately two to three times length of apophysis anterior. Ductus bursae at most one-third length of oval corpus bursae. Signum not discernible.

REMARKS. The frenulum of two out of the three females examined consists of three setae; in the remaining female it consists of three setae on one wing and two on the other.

Externally this species strongly resembles *flavonigrella* and some specimens of *mulinella* in which the fore wing pattern has a pale background and a broken stripe, although in *burdonella* the two stripes are slightly more widely separated. *M. burdonella* is clearly distinguished from *mulinella* by the club-shaped sacculus, the lobe-shaped apophysis anterior and the degree of sclerotization of the female eighth sternite. *M. burdonella* appears to be most closely related to *flavonigrella* from which it can be distinguished by the extent of the sacculus.

M. burdonella was described from an unspecified number of syntypes from Corsica: Col de Vergio and Evisa. I have examined 2 ♂ syntypes from Col de Vergio and 1 ♀ syntype from Evisa and I designate a male as lectotype. All three specimens bear the label 'Type'.

BIOLOGY. Host-plant unknown. Moths have been found in August and September.

DISTRIBUTION. Corsica and Sardinia.

MATERIAL EXAMINED (including 6 ♂, 3 ♀ genitalia preparations)

Lectotype ♂, **Corsica**: Col de Vergio, 1460 m, at light ('Lichtfang'), 31.viii.1929 (*Reisser*) (genitalia slide no. 11227; NM).

Corsica: 1 ♂ (paralectotype), Col de Vergio, 1460 m, 3.ix.1929 (*Reisser*) (NM); 3 ♂, 3 ♀, Col de Vergio, 1450, 1460 m, viii, ix (BMNH; NM); 1 ♀ (paralectotype), Evisa, 850 m, 4.ix.1929 (*Reisser*) (NM); 1 ♀, Col de Sevi, 1000 m, ix. **Sardinia**: 1 ♂, centr[al], valley ? ('vl.') Brunco Spina, 1750 m, viii; 1 ♂, S. ('merid. '), 'Musei', 120 m, ix.

Mirificarma cabezella (Chrétien)

(Figs 1, 2, 26, 53, 54, 80, 101)

Gelechia maculatella f. *cabezella* Chrétien, 1925: 245. Lectotype ♂, SPAIN (MNHN), designated by Sattler (1961: 86) [examined].

Mirificarma cabezella (Chrétien) Sattler, 1960: 42; Agenjo, 1962: 159, pl. 2, fig. 7, pl. 3, fig. 8 [legends to figs 7 and 8 are transposed on pl. 3].

♂, 6.5–7.5 mm. ♀, 6.5–7.0 mm. Head mid brown, occasionally ochreous brown. Labial palpus mottled dark brown and cream, usually predominantly cream on inner surface. Thorax and tegula as head. Fore wing (Fig. 26) mottled brown, darker in apical half; small area of dark brown at base; ochreous tinge near base. Faint cream spot at costa at three-quarters extending diffusely to dorsal margin, usually crossed medially by faint longitudinal ochreous dash. Dark brown spot across fold at one-third, extending diffusely to dorsal margin; another at end of cell, usually constricted or bisected, frequently merging with dark background. Both spots sometimes diffuse; with narrow ochreous surround. Very small, indistinct dark brown spot in fold near base.

GENITALIA ♂ (Figs 53, 54, 80). Uncus small, nearly half width of tegumen; scarcely constricted at base; apex without projection. Gnathos a moderately large, distinctly curved, simple hook. Actual margin of tegumen slightly less emarginate than sclerotized margin anteriorly. Sacculus very long, extending beyond gnathos arms, almost straight, uniformly moderately slender, smooth. Filament almost straight, very slender; extending posteriorly approximately to hind edge of vinculum; extending a short distance beyond tegumen anteriorly. Median projection of hind edge of vinculum low with indistinct dorsal V-shaped emargination; very slight median ventral emargination. Vinculum with slightly bowed pair of sclerites from saccus. Saccus usually slightly narrower towards truncate or irregular apex, extending slightly beyond

tegumen anteriorly. Aedeagus same length as tegumen plus uncus; projection near apex moderately large, weakly sclerotized, rounded.

GENITALIA ♀ (Fig. 101). Posterior margin of seventh abdominal segment without sclerotized area but with distinct dense band of scales. Invagination of membrane between eighth tergite and papillae anales funnel-shaped. Most of eighth segment sclerotized. Median longitudinal areas of sternite and tergite slightly less sclerotized than surrounding areas, slightly sunken. Tergite median longitudinal area bordered by pair of faint, narrow sclerites. Apophysis anterior rod-like, with separate, large, rounded lobe at base towards antrum; length 0.3–0.4 mm (4); apophysis posterior three to four times length of apophysis anterior. Antrum slightly curved and constricted towards anterior; anterior not indented; moderately long, longer than but less than 1.5 times length of apophysis anterior. Posterior half of antrum less sclerotized than anterior half. Ductus bursae not more than half length of oval corpus bursae. Signum not discernible.

REMARKS. The female frenulum consists of three setae. The band of scales at the posterior margin of the female abdomen, distinct in this species and in *ulicinella* and *mulinella*, is also present, although more diffuse, in some other species. The weaker sclerotization of the posterior half of the antrum is distinct in *cabezella*, although it also occurs, less noticeably, in other species including *mulinella*, *ulicinella* and *burdonella*.

The Moroccan male differs slightly in genitalia from Spanish males. The filament is slightly shorter, particularly the part apical to the tiny opening near the apex, and the saccus is almost parallel-sided, whereas it narrows slightly, towards the apex, in the Spanish specimens.

This species bears a superficial resemblance to *rhodoptera*, *scissella* and, particularly, to *constricta*. It differs from *rhodoptera* and *scissella* in many genitalic characters since these two species are in the *maculatella*-group, and from *constricta* in the shape of the uncus, saccus and filament. *M. cabezella* appears to be closely related to *mulinella* and *ulicinella*. They share the uniformly slender, straight saccus of the male, and the distinct, dense band of scales of the posterior margin of the female abdomen. *M. cabezella* differs in wing pattern and by the very slender filament of the male genitalia and the presence of the lobe at the base of the apophysis anterior of the female.

BIOLOGY. Host-plant: Genisteae: *Adenocarpus hispanicus* (Lamarck) (type-series bred by Chrétien).

Chrétien (1925: 245) found the larvae in the shoots in June; the moths emerged in September. Moths have been collected in August and October.

DISTRIBUTION. Spain and Morocco.

MATERIAL EXAMINED (including 4 ♂, 4 ♀ genitalia preparations)

Lectotype ♂, Spain: [Segovia,] La Granja ('San Ildefonso'), larva on *Adenocarpus hispanicus*, vi.1902, ex. ix. 1902 (Chrétien & Dumont) (genitalia slide no. 3562, Viette; MNHN).

Spain: 3 ♂, 2 ♀ (paralectotypes), data as lectotype, ex viii, ix.1902 (Chrétien & Dumont) (MNHN; LN); 1 ♀, —, viii (MNHN). Morocco: 1 ♂ 1 ♀, Moyen Atlas, Val d'Ifrane, 1500–1600 m, x (coll. Burmann, Innsbruck).

Mirificarma ulicinella (Staudinger)

(Figs 1, 2, 27, 55, 81, 102)

Gelechia ulicinella Staudinger, 1859: 240; Millière, 1863: 325, pl. 38, figs 8–10. LECTOTYPE ♂, SPAIN (MNHU), here designated [examined].

♂, 5.5–6.5 mm. ♀, (4.5) 5.0–6.0 mm. Head ochreous cream. Labial palpus cream mottled with brown on outer surface, usually predominantly brown towards base; predominantly cream on inner surface; apex brown. Thorax and tegula ochreous cream slightly mottled with brown; tegula usually very dark brown at base. Fore wing (Fig. 27) mottled dark and light brown; with paler yellow-ochre areas situated as follows: dorsal margin at base; along fold; median longitudinal stripe from one-third to three-quarters or near apex, adjoining fold, irregular, constricted or broken, crossed by indistinct transverse stripe or blotch at two-thirds or nearer apex; longitudinal stripe near costa from base to one-third. Two small dark brown spots on median stripe at one-third and one-half, sometimes indistinct.

GENITALIA ♂ (Figs 55, 81). Uncus small, less than one-third to less than half-width of tegumen; scarcely constricted at base; apex with tiny, pointed, median projection. Gnathos short, only slightly curved, extreme apex a small hook-shape. Actual margin of tegumen coincides with sclerotized margin anteriorly. Sacculus not reaching gnathos arms, straight, uniformly very slender, smooth. Filament curved, not spiralled; extremely stout basally, laterally compressed and dorsoventrally expanded in apical half, narrowing towards apex; extending posteriorly almost to hind edge of vinculum or slightly beyond; not usually reaching anterior of tegumen. Median projection of hind edge of vinculum with heart-shaped dorsal emargination, not emarginate ventrally. Vinculum with strongly bowed pair of sclerites from saccus. Saccus broad at base, narrowing towards truncate apex; reaching anterior of tegumen. Aedeagus same length as tegumen plus uncus or slightly shorter; projection near apex moderately large, weakly sclerotized, rounded.

GENITALIA ♀ (Fig. 102). Posterior margin of seventh abdominal segment without sclerotized area but with distinct dense band of scales. Invagination of membrane between eighth tergite and papillae anales broad, almost truncate. Most of eighth segment sclerotized; median longitudinal areas of sternite and tergite slightly less sclerotized than surrounding areas. Tergite strongly sclerotized, with pair of gently curved lobes overlapping narrow median longitudinal area. Apophysis anterior rod-like, enlarged at base towards antrum, but without separate lobe; length 0.3–0.4 mm (5); apophysis posterior three times length of apophysis anterior. Antrum slightly curved and constricted towards anterior; anterior not indented; moderately long, approximately 1.5 times length of apophysis anterior. Ductus bursae considerably shorter than oval corpus bursae. Signum not discernible.

REMARKS. The frenulum was examined in five females and consists of two setae. This species appears to be closely related to *mulinella* and *cabezella* with which it shares genitalic characters including the sacculus shape and the distinct band of scales at the posterior margin of the female abdomen. It differs in its slightly curved gnathos and shorter sacculus of the male and in the form of the eighth tergite of the female. The fore wing of *ulicinella*, with yellow-ochre areas not in a transverse zig-zag pattern, differs from all other *Mirificarma* species.

M. ulicinella was described from four specimens from Spain: Granada. I have examined 1 ♂, 1 ♀ and designate as lectotype the male which was already labelled 'lectotype' by Sattler.

BIOLOGY. Host-plant: Genisteae: *Ulex parviflorus* Pourret (= *australis* Clemente; = *provincialis* Loisel) (type-series bred by Staudinger).

The larva has been recorded from October to April in the flowers; it pupates at the base of the plant in a shell of dried leaves, the adult emerging in August; there is only one generation per year (Millière, 1863: 326; Lhomme, [1946–1948]: 566, Staudinger, 1859: 241). Moths have been collected at light and bred in September (also in May and June according to Lhomme, [1946–1948]: 566).

DISTRIBUTION. Spain and France.

Additional record. Italy: Liguria (Mariani, 1943: 166).

MATERIAL EXAMINED (including 7 ♂, 5 ♀ genitalia preparations)

Lectotype ♂, **Spain**: Granada, iv, larva on *Ulex australis*, moth emerged ix (Staudinger) (genitalia slide no. 476d, Sattler; MNHU).

Spain: 1 ♀ (paralectotype), same data as lectotype (MNHU); 23 ♂, 7 ♀, Granada province, Sierra de Alfajar, 1500 m, ix. **France**: 1 ♂, Provence. No locality data: 1 ♂.

Mirificarma mulinella (Zeller)

(Figs 1, 2, 28–30, 56, 82, 103)

Gelechia mulinella Zeller, 1839: 199; Stainton, 1865: 96, pl. 3, fig. 3. LECTOTYPE ♀, GERMANY (EAST) (BMNH), here designated [examined].

[*Anacampsis interrupta* Curtis, 1827: no. 189, folio [2]. Unjustified emendation of *interruptella* Hübner. Misidentification.]

[*Anacampsis interruptella* (Hübner) ?; Stephens, 1829: 197; Curtis, 1829 [–1831]: [91]. Incorrect subsequent spelling of *interruptella* Hübner. Misidentifications.]

[*Anacampsis interruptella* (Hübner); Stephens, 1834: 215; Westwood, 1845: 191, pl. 107, fig. 3. Incorrect subsequent spelling of *interruptella* Hübner. Misidentifications.]

Gelechia caminariella Fuchs, 1902: 323. Holotype ♀. GERMANY (WEST): [Rheinland-Pfalz,] Rheingau,

near Bornich, Rheinberge, Rieslingberg, around *Sarothamnus*, viii. 1878 (Fuchs) [not traced]. [Synonymized by Rebel, 1930: 25.]

Gelechia carminariella Fuchs; Eckstein, 1933: 134. [Incorrect subsequent spelling of *caminariella* Fuchs.]
Gelechia nigraesilvae Amsel, 1950: 27, figs 1, 2. Holotype ♂, GERMANY (WEST) (LN) [examined].
 [Synonymized by Karsholt & Nielsen, 1976: 33.]

♂, 6.0–7.5 mm. ♀ (4.5) 5.5–7.5 mm. Head cream to light brown. Labial palpus mottled brown and cream; apex dark brown; apex second segment usually mostly cream. Thorax and tegula light to mid brown often mottled with dark brown. Tegula slightly darker brown towards base. Fore wing (Figs 28–30) mottled brown, mixed with cream or light brown in apical third and occasionally also in posterior third. Dark brown spot usually present, at end of cell. Small dark brown spots sometimes present, at one-third, one in fold, one in cell. Dark brown, median, longitudinal stripe sometimes present, from one-third to apex, another in fold line. These stripes merge to form single diffuse band, or slightly separated by pale area.

GENITALIA ♂ (Figs 56, 82). Uncus small, half to almost two-thirds width of tegumen; scarcely constricted at base; apex without projection. Gnathos a moderately large, distinctly curved, simple hook; extreme apex usually a very slight hook-shape. Actual margin of tegumen coincides with sclerotized margin anteriorly. Sacculus long, reaching or extending beyond gnathos arms, straight, uniformly very slender, smooth. Filament straight or gently curved, not spiralled; stout, particularly basally, laterally compressed in apical half; not reaching hind edge of vinculum posteriorly, extending a short distance beyond tegumen anteriorly. Median projection of hind edge of vinculum high with shallow, ventral U- or V-shaped emargination. Vinculum with pair of sclerites slightly bowed or diverging from saccus. Saccus slender, almost parallel-sided with rounded or irregularly truncate apex; extending moderately well beyond tegumen anteriorly. Aedeagus slightly longer than tegumen plus uncus; projection near apex moderately large, weakly sclerotized, rounded.

GENITALIA ♀ (Fig. 103). Posterior margin of seventh abdominal segment without sclerotized area but with distinct dense band of scales. Invagination of membrane between eighth tergite and papillae anales small, broadly conical or funnel-shaped. Most of eighth segment sclerotized; median longitudinal areas of sternite and tergite slightly less sclerotized than surrounding areas; median longitudinal area of sternite slightly sunken. Tergite without pair of curved lobes. Apophysis anterior rod-like, without separate lobe at base towards antrum, slightly constricted near apex; length 0.3–0.5 mm (9); apophysis posterior three to four times length of apophysis anterior. Antrum slightly curved and constricted towards anterior; anterior not indented; moderately long, usually 1.5 times to twice length of apophysis anterior. Ductus bursae usually one-quarter to less than half length of oval or round corpus bursae. Signum not discernible.

REMARKS. The frenulum of *mulinella* consists of two setae, or two setae on one wing and three on the other. In the male genitalia, the filament basal half varies in stoutness. The fore wing pattern of this species varies by degrees from almost uniform to a pale background contrasting with a dark broken or unbroken stripe. The contrasted form tends to occur particularly in southern France and southern England. The specimens with an unbroken stripe bear a strong superficial resemblance to *interruptella* although the contrast of pale and dark areas is never as great in *mulinella* as it is in *interruptella*. Specimens with a broken stripe on a pale background sometimes closely resemble *flavonigrella* and *burdonella*, although the more apical stripe is slightly longer than in *burdonella*.

M. mulinella can be distinguished from these by its uniformly slender sacculus and its rod-like apophysis anterior. It appears to be closely related to *ulicinella* and *cabezella*, since the genitalia are similar, although the fore wing pattern differs. The male genitalia differ from those of *ulicinella* in the shape of the gnathos, and from *cabezella* in the shape of the filament and the median projection of the hind edge of the vinculum. In the female genitalia, *mulinella* can be distinguished from *ulicinella* by the form of the eighth tergite and from *cabezella* by the absence of lobes at the base of the apophysis anterior.

M. mulinella was described from 2 ♂, 4 ♀ from East Germany: Dresden and Poland: Głogów ('Glogau'). I designate as lectotype the single type-specimen examined, from Dresden, which was already labelled 'lectotype' by Sattler.

BIOLOGY. Host-plants: Genisteae: *Ulex europaeus* L. (Stainton, 1865: 228); *Cytisus scoparius* (L.) Link (formerly in *Sarothamnus*) (specimens bred by Pitkin and Sattler, England; Stainton, 1865: 228); *C. nigricans* L. (Hartig, 1964: 27); *Genista germanica* L. (Sorhagen, 1886: 187); *Calicotome spinosa* (L.) Link (Lhomme, [1946–1948]: 593).

In Great Britain, the only published host-plant records for *mulinella* are *Ulex* and *C. scoparius*; however, I have seen specimens bred by Agassiz from a cultivar of *Genista tinctoria* L. This plant is the host of the only other species of *Mirificarma* in Great Britain, *lentiginosella*. Specimens of *mulinella* have also been bred by Langmaid (pers. comm.) from *Lupinus arboreus* Sims in Great Britain (Hampshire).

Outside Great Britain, *Spartium* has been recorded as a host-plant by Mariani (1943: 167); however, this should probably be referred to *C. scoparius*, known as *Spartium scoparium* by some authors including Stainton (1867: 26). A record of *Bartsia aspera* (Brotero) Lange (Scrophulariaceae) (Zerkowitz, 1946: 133) as a host-plant of *mulinella* is very dubious.

The larva occurs from April to early May; on *Ulex* and *C. scoparius* it makes a small hole in a bud that is not fully open and feeds on the interior of the flower, before repeating the process in another flower. It pupates on the ground in a slight cocoon amongst leaves (Stainton, 1865: 96). The larva is found on the leaves instead of the flowers on *L. arboreus*, which, unlike *Ulex* and *C. scoparius*, does not have reduced leaves (Langmaid, pers. comm.).

The larva is also found in June (Sorhagen, 1886: 187). The pupal stage is in May and June (Bradford, [1979]: 123). Moths have been collected from July to November, also in February in North Africa.

DISTRIBUTION. Europe west of 20°E, north to Denmark, extending south to North Africa (Algeria, Tunisia). The published distribution extends further north, to Orkney Is. (Wolff, 1971: 161) and Norway (Opheim, 1978: 27). This widespread species is found further north than any other *Mirificarma* species.

Additional records. Portugal (Zerkowitz, 1946: 133); E. Ireland (Meyrick, 1895: 603); Channel Is.: Jersey (Sattler, pers. comm.); Belgium (Lhomme, [1946–1948]: 593); Netherlands (Lempke, 1976: 26); Sweden (Krogerus *et alii*, 1971: 21); Switzerland (Müller-Rutz, 1914: 486); U.S.S.R.: European part (Piskunov, 1981: 674).

MATERIAL EXAMINED (including 13 ♂, 11 ♀ genitalia preparations)

Lectotype ♀ (*mulinella*), **Germany (East)**: Dresden ('mis. Tischer') (genitalia slide no. 22493). Holotype ♂ (*nigraesilvae*), **Germany (West)**: Baden-Württemberg, Schwarzwald, Villengen district, Buchenberg, 22.vii.1947 (*Amsel*) (genitalia slide no. 827; LN).

Great Britain (England): 77 ex., —; 3 ex., Cheshire; 1 ♀, Salop; 2 ♂, 1 ♀, Wiltshire; 7 ♂, 3 ♀, Hampshire; 1 ♀, 3 ex., Sussex; 6 ♂, 5 ♀, London; 1 ♀, Lincolnshire; 1 ♂, Norfolk; 33 ex., Kent; vii–ix. **Channel Is.**: 1 ex., Guernsey (coll. Peet, Guernsey). **Spain**: 1 ♂, 1 ♀, Gerona, ix. **France**: 1 ♀, Basses-Pyrénées; 1 ♀, Pyrénées-Orientales; 1 ♀, Alpes-Maritimes; viii, ix ? **Denmark**: 1 ♂, NE. Jylland (ZM); 1 ♀, Sjaelland (ZM); viii. **Germany**: 1 ♂, 1 ♀, —; 3 ♂, Berlin, vi, vii. **Germany (West)**: 1 ♂, 1 ♀, Hamburg (coll. Jäckh, Bidingen); 1 ♂, Nordrhein-Westfalen (coll. Jäckh, Bidingen); 1 ♂, Hessen ?; viii. **Italy**: 2 ♂, 1 ♀, Liguria, ix (coll. Jäckh, Bidingen). **Sardinia**: 2 ♀, ix. **Sicily**: 1 ♂. **Austria**: 1 ♂ (NM). **Poland**: 1 ♀, Szczecin (NM); 1 ♂, 2 ♀, Wrocław (BMNH; NM). **Yugoslavia**: 2 ♂, 3 ♀, Dalmatia; ix–xi (NM). **Algeria**: 1 ♀, Constantine province, x. **Tunisia**: 1 ♂, 1 ♀, ii, x (NM). No locality data: 70 ex.

References

- Agenjo, R.** 1962. Resultados científicos de una Pensión de Estudios en el 'Muséum National d'Histoire Naturelle' de Paris, con la descripción de un género y otra especie nuevos de lepidópteros españoles, dedicados al Excmo. Sr. D. Jesús Rubio y García-Mina, Ministro de Educación Nacional. *Eos. Revista Española de Entomología* 38: 147–189, figs 1–6, pls 2–6.
- 1968. Catálogo ordenador de los Lepidópteros en España. Vigésimo novena familia bis. Gelechiidae. *Graellsia* 23, Appendix: [1]–[8].
- Amsel, H. G.** 1935. Weitere Mitteilungen über palästinensische Lepidopteren. *Veröffentlichungen aus dem Deutschen Kolonial- und Übersee-Museum in Bremen* 1: 223–277.
- 1950. Kleinschmetterlinge aus dem badischen Schwarzwald. *Beiträge zur naturkundlichen Forschung in Südwestdeutschland* 9: 26–28, figs 1–2.
- 1959. Portugiesische Kleinschmetterlinge gesammelt von Teodoro Monteiro, O.S.B. *Anais da Faculdade de Ciências do Porto* 41: 1–20, pls 1–2.
- Anonymous** 1969. European clover leaf tier. *Plant Protection Bulletin*. F.A.O. 17: 69.
- Bradford, E. S.** [1979]. Gelechiidae. In Emmet, A. M. (Ed.), *A field guide to the smaller British Lepidoptera* pp. 115–132. London.

- Bradley, J. D.** 1966. Type specimens of Microlepidoptera in the University Museum, Oxford, described by Haworth. *Entomologist's Gazette* **17**: 129–140.
- Bruand d'Uzelle, C. T.** 1859. Observations entomologiques faites en 1858, relativement aux *Plogophora scita*, *Sericornis astrana* et *Gelechia vicinella*. *Annales de la Société Entomologique de France* (1858) (3) **6**: 477–483.
- Căpușe, I.** 1964. Über drei Arten paläarktischer Gelechiidae: *Carpatolechia dimitrescui* n. g., n. sp. *Approaerema aureliana* n. sp. und *Mirificarma formosella* (Hb.) n. comb. (Lepidoptera: Gelechiidae). *Entomologisk Tidskrift* **85**: 12–19.
- Caradja, A.** 1920. Beitrag zur Kenntnis der geographischen Verbreitung der Mikrolepidopteren des palaearktischen Faunengebietes nebst Beschreibung neuer Formen. III Teil. *Deutsche Entomologische Zeitschrift, Iris* **34**: 75–179.
- Chambers, V. T.** 1872. Micro-lepidoptera [continued]. *Canadian Entomologist* **4**: 146–150.
- Chrétien, P.** 1915. Contribution à la connaissance des Lépidoptères du nord de l'Afrique. *Annales de la Société Entomologique de France* **84**: 289–374, figs 1–11.
- 1925. La légende de *Graëllsia isabellae*. Appendice. *Amateur de Papillons* **2**: 241–247, 257–263.
- Curtis, J.** 1827. *British Entomology; being illustrations and descriptions of the genera of insects found in Great Britain and Ireland: containing coloured figures from nature of the most rare and beautiful species, and in many instances of the plants upon which they are found.* **4**, nos 147–194, pls 147–194. London.
- 1829 [–1831]. *A guide to an arrangement of British insects; being a catalogue of all the named species hitherto discovered in Great Britain and Ireland.* vi + [128] pp. London.
- [**Denis, M. & Schiffermüller, I.**] 1775. *Ankündigung eines systematischen Werkes von den Schmetterlingen der Wienergegend.* 323 pp., 3 pls. Wien.
- Disqué, H.** 1908. Versuch einer microlepidopterologischen Botanik. *Deutsche Entomologische Zeitschrift, Iris* **21**: 34–80, 81–147.
- Dumont, C.** 1931. Contribution à l'étude des Lépidoptères du nord de l'Afrique (suite). Description et éthologie de trois espèces nouvelles. *Bulletin de la Société Entomologique de France* **1931**: 148–153, figs 1–2.
- Duponchel, P.-A.-J.** 1842–[1844]. Nocturnes, supplement aux tomes quatrième et suivants. In Godart, J.-B., *Histoire naturelle des Lépidoptères ou papillons de France.* Supplement 4. 534 pp., pls 51–90. Paris.
- Eckstein, K.** 1933. *Die Schmetterlinge Deutschlands mit besonderer Berücksichtigung ihrer Biologie und wirtschaftlichen Bedeutung.* **5.** Die Kleinschmetterlinge Deutschlands. 223 pp., 32 pls. Stuttgart.
- Fuchs, A.** 1902. Neue Geometriden und Kleinfalter des europäischen Faunengebiets. *Stettiner Entomologische Zeitung* **63**: 317–330.
- Gaede, M.** 1937. Gelechiidae. *Lepidopterorum Catalogus* **79**, 630 pp.
- Gomes, C. M. R., Gottlieb, O. R., Gottlieb, R. G. & Salatino, A.** 1981. Phytochemistry in perspective: chemosystematics of the Papilionoideae. In Polhill, R. M. & Raven, P. H. (Eds), *Advances in legume systematics.* Part 2: pp. i–v + 427–1094. Kew.
- Gozmány, L. A.** 1955. Notes on some Hungarian Gelechioidea and Coleophoridae. *Annales Historico-Naturales Musei Nationalis Hungarici* (S.N.) **6**: 307–320, figs 1–24.
- 1958. Microlepidoptera IV. *Fauna Hungariae* **40**: 1–295, 1–8 [index], figs 1–145.
- Guenée, A.** 1849. In Lucas, H., *Exploration scientifique de l'Algérie pendant les Années 1840, 1841, 1842.* Zoologie. Histoire naturelle des animaux articulés **3**, 527 pp. *Ibid.* **4**, Lépidoptères, pls 1–4. Paris.
- Hartig, F.** 1964. Microlepidotteri della Venezia Tridentina e delle regioni adiacenti. Parte III. (Fam. Gelechiidae-Micropterygidae). *Studi Trentini di Scienze Naturali* **41** (3–4): 1–292.
- Hartig, F. & Amsel, H. G.** 1951. Lepidoptera Sardinica. *Fragmenta Entomologica* **1**: 3–152.
- Hauder, F.** 1918. Einige Kleinschmetterlings-Aberrationen. *Entomologische Zeitschrift* **31**: 97–98, 102–103.
- Hofmann, E.** 1875. *Die Kleinschmetterlingsraupen – Microlepidoptera – in systematischer Reihenfolge nach dem Cataloge von Dr. Staudinger & Dr. Wocke 1871. Zugleich als Ergänzung von S. v. Praun's Microlepidoptera.* iv + 221 pp., 10 pls. Nürnberg.
- Hrubý, K.** 1964. *Prodromus Lepidopter Slovenska.* 962 pp., 14 maps. Bratislava.
- Hübner, J.** 1793. *Sammlung auserlesener Vögel und Schmetterlinge, mit ihren Namen.* 16 pp., 100 pls. Augsburg.
- 1796–[1836]. *Sammlung europäischer Schmetterlinge* **8**, 78 pp. (1796), 71 pls (1796–[1836]). Augsburg.
- 1816–[1825]. *Verzeichniss bekannter Schmettlinge.* 431 pp. Augsburg.
- 1822. *Systematisch-alphabetisches Verzeichniss aller bisher bey den Fürbildungen zur Sammlung*

- europäischer Schmetterlinge angegebenen Gattungsbenennungen; mit Vormerkung auch augsburgischer Gattungen.* vi + 81 pp. Augsburg.
- Humphreys, H. N. & Westwood, J. O.** [1843–]1845. *British moths and their transformations*. 2. xix + 268 pp., pls 57–124. London.
- Karsholt, O. & Nielsen, E. S.** 1976. *Systematisk fortegnelse over Danmarks sommerfugle*. 128 pp. Klampenborg, Denmark.
- Klimesch, J.** 1961. Ordnung Lepidoptera. I. Teil: Pyralidina, Tortricina, Tineina, Eriocraniina und Micropterygina. In Franz, H., *Die Nordost-Alpen im Spiegel ihrer Landtierwelt*. 2: 481–789.
- Klots, A. B.** 1956. Lepidoptera. In Tuxen, S. L. (Ed.), *Taxonomist's glossary of genitalia in insects*. Pp. 97–111, figs. 121–132. Copenhagen.
- Koçak, A. Ö.** 1982. Additions and corrections to the names published in 'Systematic and Synonymic List of the Lepidoptera of France, Belgium and Corsica' by Leraut, 1980. *Priamus* 2: 97–133.
- Krogerus, H., Opheim, M., Schantz, M. von, Svensson, I & Wolff, N. L.** 1971. *Catalogus Lepidopterorum Fenniae et Scandinaviae. Microlepidoptera*. 40 pp. Helsinki.
- Kupicha, F. K.** 1977. The delimitation of the tribe Viciae (Leguminosae) and the relationships of *Cicer* L. *Botanical Journal of the Linnean Society of London* 74: 131–162.
- Kuznetsov, V. I. & Stekol'nikov, A. A.** 1978. Systematic position and phylogenetic relationships of the superfamily Coleophoroidea (Lepidoptera: Oecophoridae, Coleophoridae, Ethmiidae) treated on the base of functional morphology of the male genitalia. *Entomologičesko Obozrenie* 57: 131–149, figs 1–11. [In Russian.]
- 1979. The systematic position and phylogenetic relationships of the superfamily Coleophoroidea (Lepidoptera: Oecophoridae, Coleophoridae, Ethmiidae) as revealed by the functional morphology of the male genitalia. *Entomological Review* (1978) 57: 91–103, figs 1–11. [English translation of Kuznetsov & Stekol'nikov, 1978.]
- Lempke, B. J.** 1976. *Naamlijst van de Nederlandse Lepidoptera*. 100 pp. [Amsterdam.]
- Lhomme, L.** [1946–1948]. *Catalogue des Lépidoptères de France et de Belgique*. 2 (4): 489–648. Douelle (Lot).
- [1948–1949]. *Catalogue des Lépidoptères de France et de Belgique*. 2 (5): 649–808.
- Mann, J.** 1866. Aufzählung der im Jahre 1865 in der Dobrudscha gesammelten Schmetterlinge. *Verhandlungen der Zoologisch-Botanischen Gesellschaft in Wien* 16: 321–360.
- Mariani, M.** 1941, 1943. Fauna Lepidopterorum Italiae. Parte 1 – Catalogo ragionato dei Lepidotteri d'Italia. *Giornale di Scienze Naturali ed Economiche di Palermo* 42 (3): 1–79 (1941), 81–237 (1943), 1 pl.
- Meess, A.** 1910. See Spuler, A. 1903–1910.
- Meyrick, E.** 1895. *A handbook of British Lepidoptera*. [vi] + 843 pp. London.
- 1925. Lepidoptera Heterocera. Fam. Gelechiidae. *Genera Insectorum* 184: 1–290, pls 1–5.
- Millière, P.** 1859–1864. *Iconographie et description de chenilles et Lépidoptères inédits* 1, 424 pp., 50 pls. Paris.
- Müller-Rutz, J.** 1913–1914. xxxiv. Gelechiidae. Pp. 453–500. In Vorbrod, K. & Müller-Rutz, J., *Die Schmetterlinge der Schweiz* 2: 727 pp., 2 tables. Bern.
- Nickerl, O.** 1908. *Beiträge zur Insekten-Fauna Böhmens*. 6. Die Motten Böhmens (Tineen). [viii] + 161 pp. Prag.
- Opheim, M.** 1978. *The Lepidoptera of Norway, check-list*. Part III Gelechioidea (first part). 30 pp. Trondheim.
- Piskunov, V. I.** 1981. 50. Gelechiidae. In Zagulaev, A. K. et alii, [Key to insects in the European part of the U.S.S.R. 4: Lepidoptera, pt 2]. Pp. 649–748, figs 608–675. Leningrad. [In Russian.]
- Polhill, R. M. & Raven, P. H.** (Eds) 1981. *Advances in legume systematics*. Part 1. xvi + 425 + xxi pp. Kew.
- Pröse, H.** 1957. II. Spezieller Teil: Systematische Liste. B. Microlepidoptera. In Daniel, F. & Wolfsberger, J., *Die Föhrenheidegebiete des Alpenraumes als Refugien wärmeliebender Insekten. II. Der Sonnenberghang bei Naturns im Vintschgau (Südtirol)*. *Mitteilungen der Münchener Entomologischen Gesellschaft* 47: 21–121, 2 maps.
- Rebel, H.** 1901. Famil. Pyralidae – Micropterygidae. In Staudinger, O. & Rebel, H., *Catalog der Lepidopteren des palaearctischen Faunengebietes* 2, 368 pp. Berlin.
- 1903. Studien über die Lepidopterenfauna der Balkenländer. I. Teil. Bulgarien und Ostrumelien. *Annalen des (K.K.) Naturhistorischen (Hof) Museums* 18: 123–347, pl. 3.
- 1914. Zweiter Beitrag zur Lepidopterenfauna Unter-Aegyptens. *Deutsche Entomologische Zeitschrift, Iris* 28: 258–270, pl. 4; figs 1–8.
- 1930. Zwei neue Gelechiidae aus Korsika. *Zeitschrift des Österreichischen Entomologen-Vereines, Wien* 15: 25–26.
- 1931. In Rebel, H. & Zerny, H., *Die Lepidopterenfauna Albaniens (mit Berücksichtigung der*

- Nachbargebiete). *Denkschriften der Kaiserlichen Akademie der Wissenschaften* **103**: 37–161, figs 1–10, pl. 1, map. [Dated 1931 on wrapper of reprint.]
- Rothschild, N. C.** 1913. Adatok Magyarországi lepkefaunájához (Beiträge zur Lepidopterenfauna Ungarns). *Rovartani Lapok* **20**: 66–91, pl. 2.
- Sattler, K.** 1960. Generische Gruppierung der europäischen Arten der Sammelgattung *Gelechia* (Lepidoptera, Gelechiidae). *Deutsche Entomologische Zeitschrift* (N.F.) **7**: 10–118, figs 1–138.
- 1961. Über *Mirificarma cabezella* (Chrét., 1925). *Zeitschrift der Wiener Entomologischen Gesellschaft* **46**: 86–88, figs 1–4.
- 1976. A taxonomic revision of the genus *Ornathalva* Gozmány, 1955 (Lepidoptera: Gelechiidae). *Bulletin of the British Museum (Natural History)* (Entomology) **34**: 87–152, 27 pls, 27 figs.
- 1979. A taxonomic revision of the genus *Deltophora* Janse, 1950 (Lepidoptera: Gelechiidae). *Bulletin of the British Museum (Natural History)* (Entomology) **38**: 263–322, 112 figs.
- Schille, F.** 1931. Fauna motyli Polski. 2. *Prace Monograficzne Komisji Fizjograficznej* **7**: 1–358.
- Schütze, K. T.** 1931. *Die Biologie der Kleinschmetterlinge unter besonderer Berücksichtigung ihrer Nährpflanzen und Erscheinungszeiten*. 235 pp. Frankfurt.
- Sorhagen, L.** 1886. *Die Kleinschmetterlinge der Mark Brandenburg und einiger angrenzenden Landschaften mit besonderer Berücksichtigung der Berliner Arten*. x + 368 pp. Berlin.
- Spuler, A.** 1903–1910. *Die Schmetterlinge Europas*. 2: [vi] + 523 pp, figs 1–151, 27–239, 21 pls. Stuttgart.
- Stainton, H. T.** 1865. *The natural history of the Tineina* **9**, [vii] + 276 pp., pls 1–8. London, Paris, Berlin.
- 1867. *The natural history of the Tineina* **10**, xi + 304 pp., pls 10–16. London, Paris, Berlin.
- Staudinger, O.** 1859. Diagnosen nebst kurzen Beschreibungen neuer andalusischer Lepidopteren. *Stettiner Entomologische Zeitung* **20**: 211–259.
- 1871. Beitrag zur Lepidopterenfauna Griechenlands. *Horae Societatis Entomologicae Rossicae* **7**: 3–304, pls 1–3.
- Stephens, J. F.** 1829. *A systematic catalogue of British insects, etc.* 2. Insecta Haustellata. 388 pp. London.
- 1834–1835. *Illustrations of British entomology, etc.* Haustellata **4**. 436 pp., pls 33–41. London.
- Treitschke, F.** 1832. *Die Schmetterlinge von Europa* **9** (1), viii + 262 pp. Leipzig.
- 1833. *Die Schmetterlinge von Europa* **9** (2), 294 pp. Leipzig.
- Turati, E.** 1924. Spedizione Lepidotterologica in Cirenaica 1921–1922. *Atti della Società Italiana di Scienze Naturali e del Museo Civico di Storia Naturale* **63**: 21–191, figs 1–7, pls 1–6.
- Tutin, T. G., Heywood, V. H., Burges, N. A., Moore, D. M., Valentine, D. H., Walters, S. M. & Webb, D. A.** (Eds), 1964–1980. *Flora Europaea*. 5 vols. Cambridge.
- Villers, C. de** 1789. *Caroli Linnaei Entomologia Faunae Suecicae descriptionibus aucta* **2**: xvi + 656 pp., pls 4–6. Lugduni.
- Walsingham, Lord** 1904. Algerian Microlepidoptera. *Entomologist's Monthly Magazine* **40**: 214–223, 265–273.
- Wocke, M.** 1861. II. Microlepidoptera. In Staudinger, O. & Wocke, M., *Catalog der Lepidopteren Europa's und der angrenzenden Länder*. xvi + 192 pp. Dresden.
- 1871. II. Microlepidoptera. In Staudinger, O. & Wocke, M., *Catalog der Lepidopteren des europaischen Faunengebiets*. xxxviii + 426 pp. Dresden.
- Wolff, N. L.** 1971. Lepidoptera. *Zoology of Iceland* **3** (45): 193 pp., figs 1–33, pls 1–15.
- Zeller, P. C.** 1839. Versuch einer naturgemässen Eintheilung der Schaben. *Isis von Oken* **1839**: 167–220.
- 1847. Bemerkungen über die auf einer Reise nach Italien und Sicilien beobachteten Schmetterlingsarten. IX. *Isis von Oken* **1847**: 801–859.
- Zerkowitz, A.** 1946. The Lepidoptera of Portugal. *Journal of the New York Entomological Society* **54**: 51–87, 115–165, 211–261.
- Zerny, H.** 1936. Die Lepidopterenfauna des Grossen Atlas in Marokko und seiner Randgebiete. *Mémoires de la Société des Sciences Naturelles (et Physiques) du Maroc* **42**: 1–163, figs 1–4, pls 1, 2.



6



7



8



9



10



11

Figs 6–11 Wings of *Mirificarma* species. 6, *M. montivaga* (Walsingham). 7, *M. scissella* (Chrétien). 8, *M. rhodoptera* (Mann). 9, *M. denotata* sp. n. 10, *M. maculatella* (Hübner). 11, *M. pallidipulchra* (Walsingham).



12



13



14



15



16



17

Figs 12–17 Wings of *Mirificarma* species. 12, *M. aflavella* (Amsel). 13, *M. flavella* (Duponchel). 14, *M. eburnella* ([Denis & Schiffermüller]). 15, 16, variation in *M. ocellinella* (Chrétien). 17, *M. fasciata* sp. n.



18



19



20



21



22

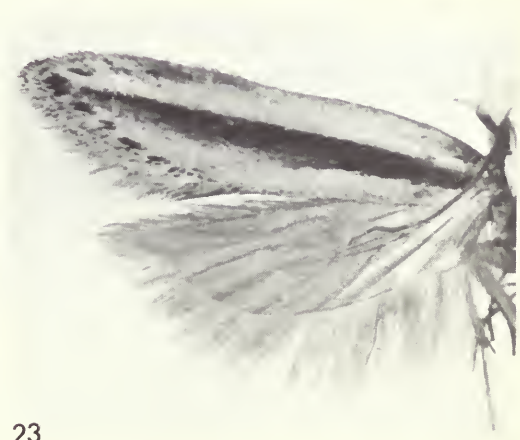

23

Figs. 18–23 Wings of *Mirificarma* species. 18, *M. lentiginosella* (Zeller). 19, *M. constricta* sp. n. 20, *M. cytisella cytisella* (Treitschke). 21, *M. cytisella leonella* Amsel. 22, *M. monticolella* (Rebel). 23, *M. interruptella* (Hübner).



24

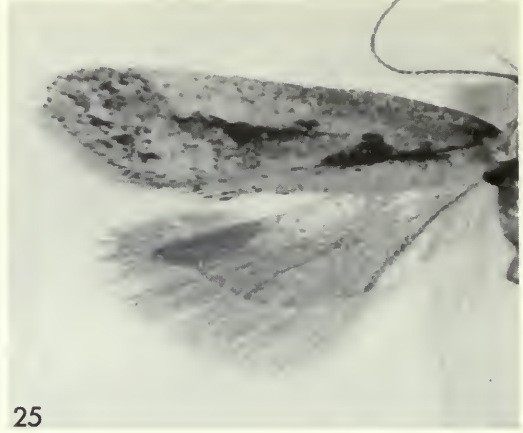

25



26



27

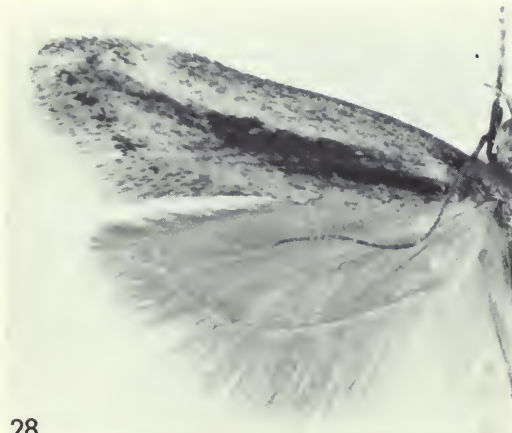

28



29

Figs 24–29 Wings of *Mirificarma* species. 24, *M. flavonigrella* (Chrétien). 25, *M. burdonella* (Rebel). 26, *M. cabezella* (Chrétien). 27, *M. ulicinella* (Staudinger). 28, 29, variation in *M. mulinella* (Zeller).



Fig. 30 Wings of *Mirificarma mulinella* (Zeller).

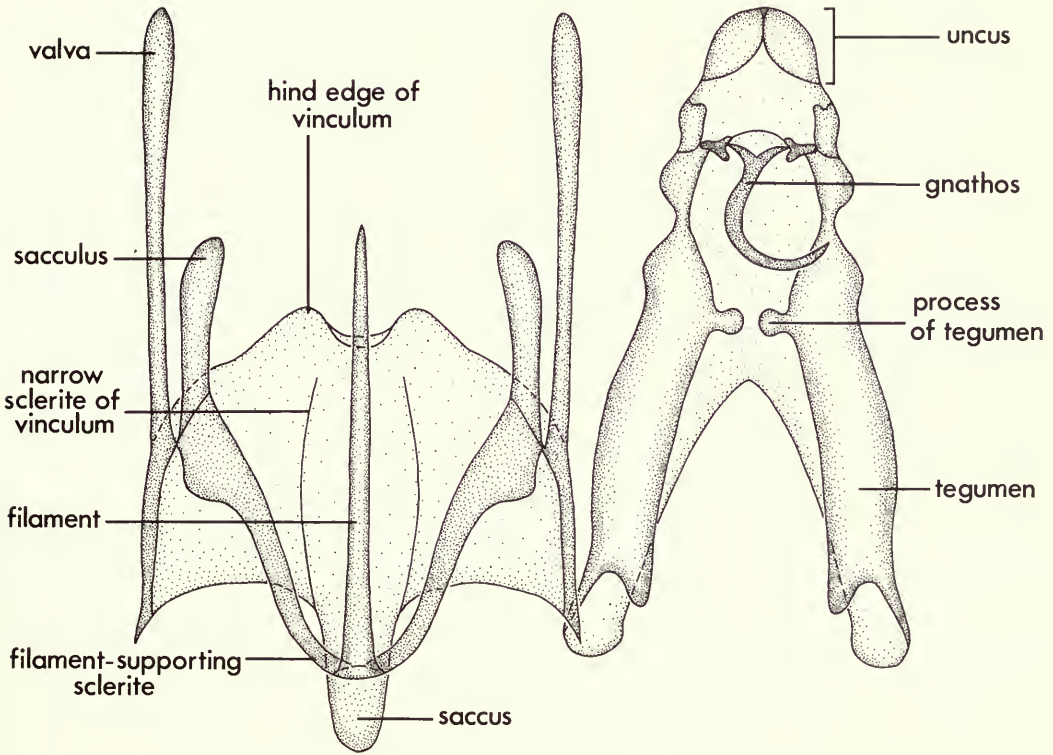
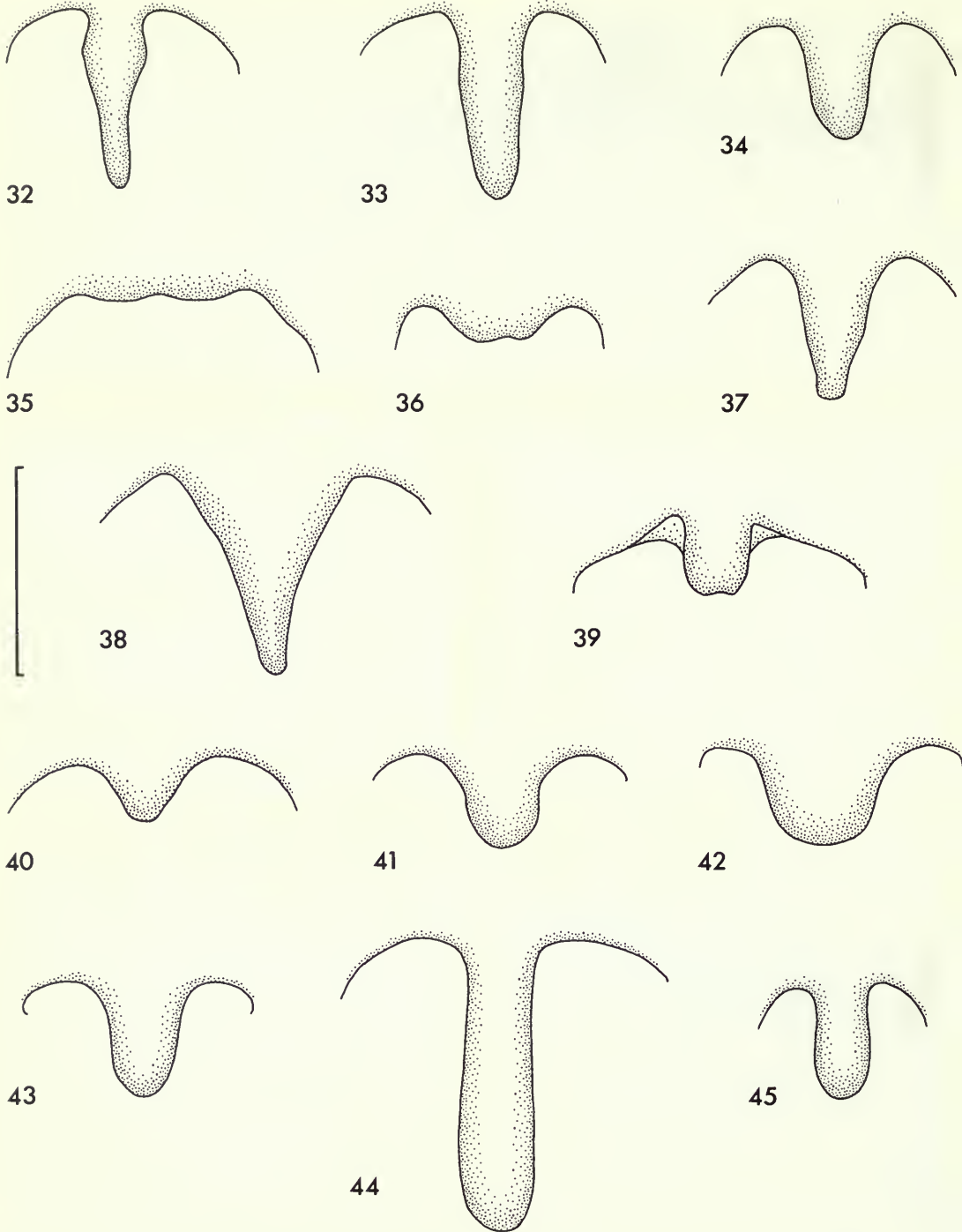
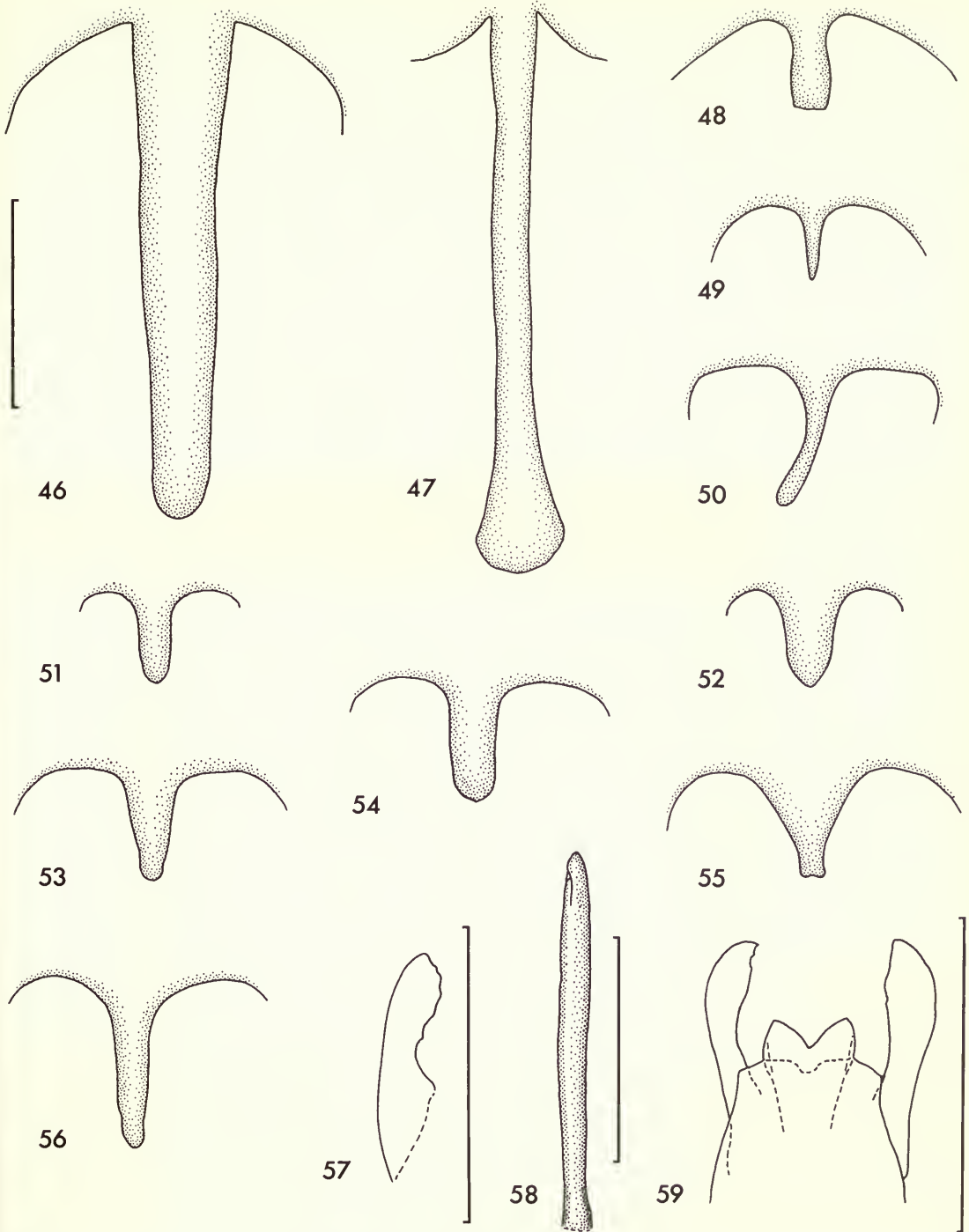

Fig. 31 Schematic diagram of the ♂ genitalia of *Mirificarma* combining some features of the different species-groups.



Figs 32–45 Saccus of *Mirificarma* species. 32, 33, variation in *M. montivaga* (Walsingham). 34, *M. scissella* (Chrétien). 35, *M. rhodoptera* (Mann), typical form. 36, *M. rhodoptera* (Mann), small form. 37, *M. denotata* sp. n. 38, *M. maculatella* (Hübner). 39, *M. pallidipulchra* (Walsingham). 40, *M. aflavella* (Amsel). 41, 42, variation in *M. flavella* (Duponchel). 43, *M. eburnella* ([Denis & Schiffermüller]). 44, *M. lentiginosella* (Zeller). 45, *M. constricta* sp. n. Scale = 0.25 mm.



Figs 46-59 *Mirificarma* species. 46-56, saccus, scale = 0.25 mm. (46) *M. ocellinella* (Chrétien); the specimen figured is shorter than average. (47) *M. fasciata* sp. n. (48) *M. cytisella cytisella* (Treitschke). (49) *M. monticolella* (Rebel). (50) *M. interruptella* (Hübner). (51) *M. flavonigrella* (Chrétien). (52) *M. burdonella* (Rebel). (53) *M. cabezella* (Chrétien), Spain. (54) *M. cabezella* (Chrétien), Morocco. (55) *M. ulicinella* (Staudinger). (56) *M. mulinella* (Zeller). 57-59, scale = 0.25 mm. (57) left sacculus of *M. monticolella* (Rebel). (58) aedeagus of *M. monticolella* (Rebel). (59) sacculi and hind edge of vinculum of *M. flavonigrella* (Chrétien).



60

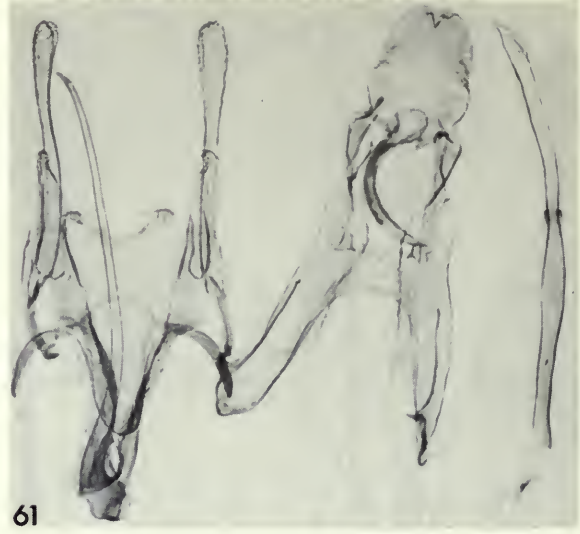

61



62



63

Figs 60–63 Genitalia of *Mirificarma* ♂. 60, *M. montivaga* (Walsingham). 61, *M. scissella* (Chrétien). 62, *M. rhodoptera* (Mann), typical form. 63, aedeagus of *M. rhodoptera* (Mann), small form.



64



65



66

Figs 64-66 Genitalia of *Mirificarma* ♂. 64, *M. denotata* sp. n. 65, *M. maculatella* (Hübner). 66, *M. pallidipulchra* (Walsingham).



67



68



69

Figs 67–69 Genitalia of *Mirificarma* ♂. 67, *M. aflavella* (Amsel). 68, *M. flavella* (Duponchel). 69, *M. eburnella* ([Denis & Schiffermüller]).

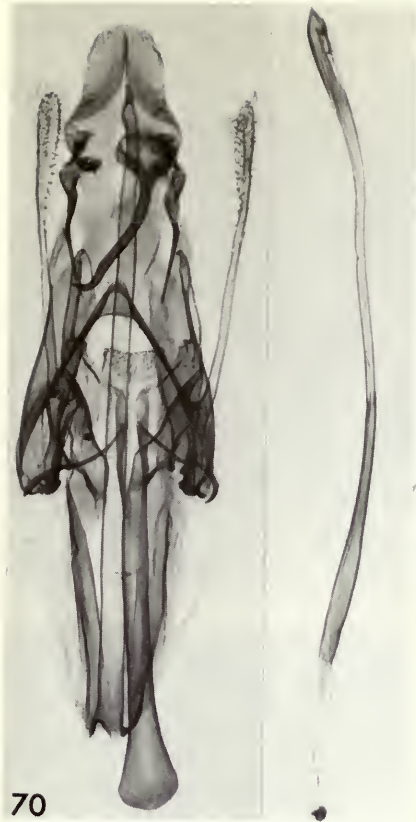

70



71



72

Figs 70–72 Genitalia of *Mirificarma* ♂. 70, *M. fasciata* sp. n. 71, *M. ocellinella* (Chrétien). 72. *M. lentiginosella* (Zeller); the uncus of the figured specimen is broader than average.



73



74



75



76

Figs 73–76 Genitalia of *Mirificarma* ♂. 73, *M. constricta* sp. n. 74, *M. cytisella leonella* Amsel. 75, *M. cytisella cytisella* (Treitschke), typical form. The major difference between Figs 74 and 75 is indicated by arrows. 76, *M. monticolella* (Rebel); some features which were indistinct in this photograph have been outlined.



77



78



79

Figs 77-79 Genitalia of *Mirificarma* ♂. 77, *M. interruptella* (Hübner). 78, *M. flavonigrella* (Chrétien). 79, *M. burdonella* (Rebel).

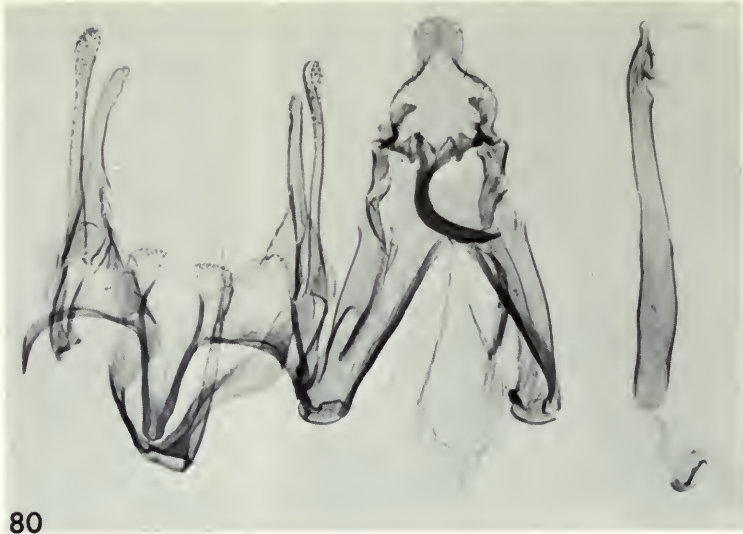

80



81

Figs 80, 81 Genitalia of *Mirificarma* ♂. 80, *M. cabezella* (Chrétien). 81, *M. ulicinella* (Staudinger).



82



83



84

Figs 82–84 *Mirificarma* ♂. 82, genitalia of *M. mulinella* (Zeller). 83, 84, eighth abdominal segment with coremata. (83) *M. ocellinella* (Chrétien). (84) *M. interruptella* (Hübner).



85



86



87



88

Figs 85–88 Genitalia of *Mirificarma* ♀. 85, *M. montivaga* (Walsingham). 86, *M. rhodoptera* (Mann), typical form. 87, *M. rhodoptera* (Mann), small form. 88, *M. denotata* sp. n. Scale = 0.1 mm and applies to signa only.



89

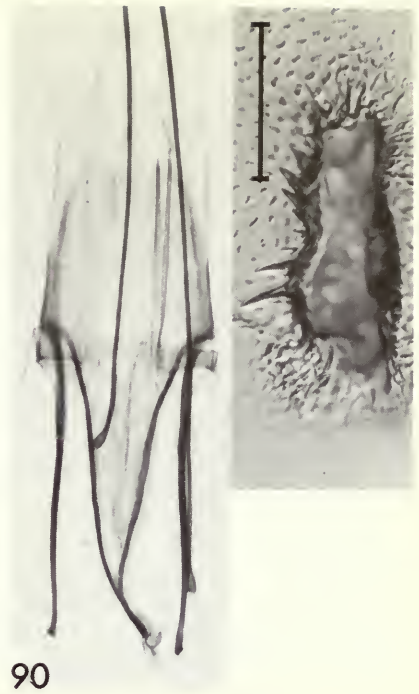

90

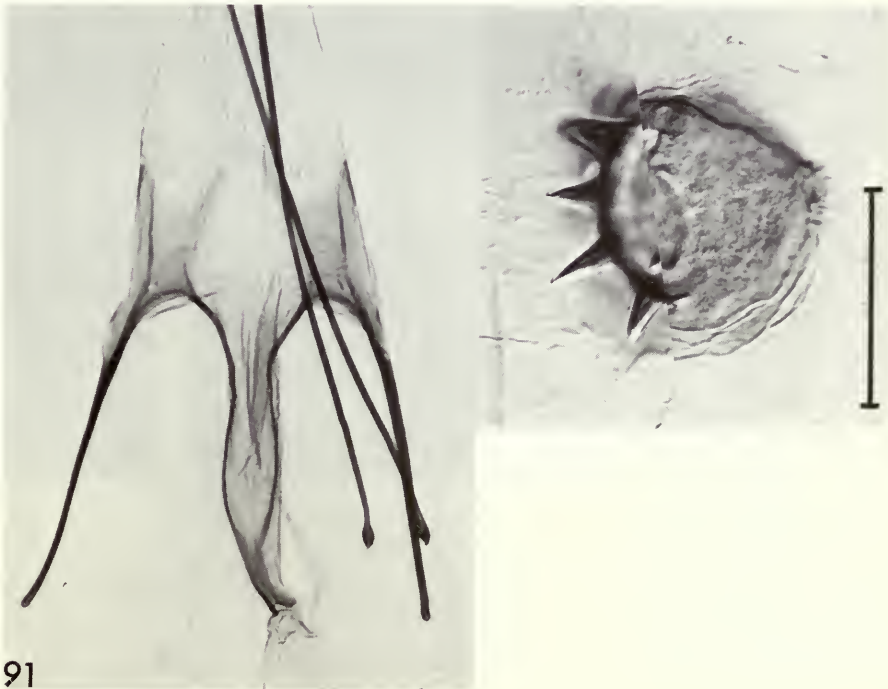

91

Figs 89-91 Genitalia of *Mirificarma* ♀. 89, *M. maculatella* (Hübner). 90, *M. pallidipulchra* (Walsingham). 91, *M. aflavella* (Amsel). Scale = 0.1 mm and applies to signa only.

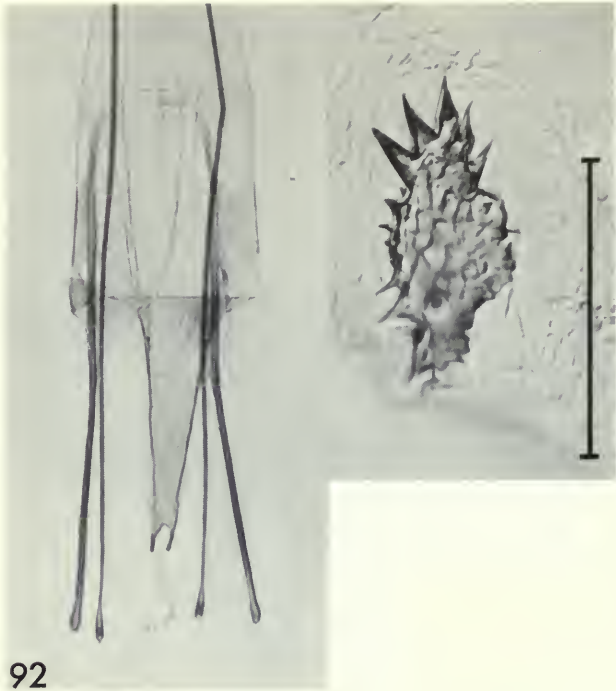

92



93



94

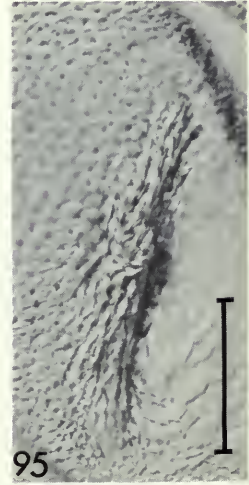
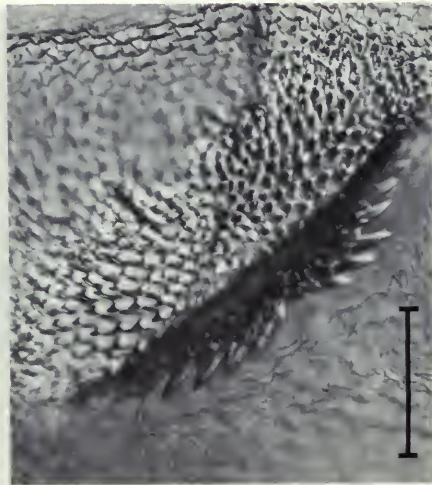

95

Figs 92-95 Genitalia of *Mirificarma* ♀. 92, *M. flavella* (Duponchel). 93, *M. eburnella* ([Denis & Schiffmüller]). 94, 95, *M. ocellinella* (Chrétien) and variation in the signum. Scale = 0.1 mm and applies to signa only.

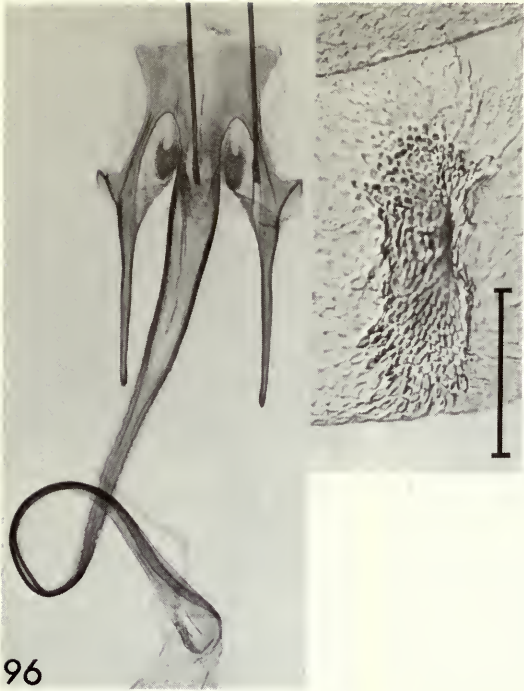

96

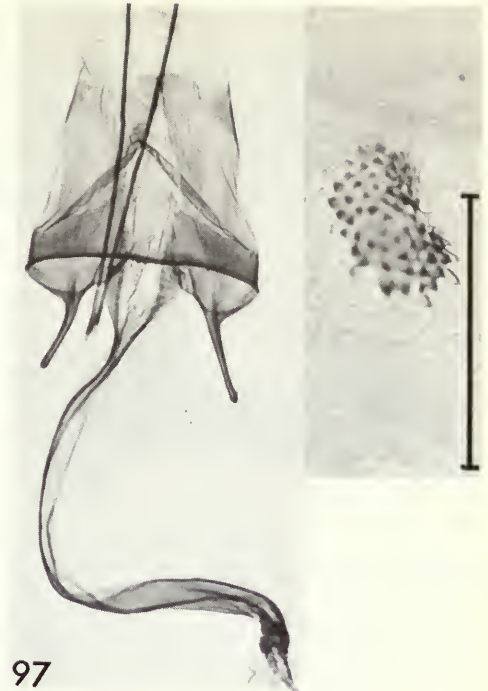

97



98

Figs 96–98 Genitalia of *Mirificarma* ♀. 96, *M. fasciata* sp. n. 97, *M. lentiginosella* (Zeller). 98, *M. cytisella cytisella* (Treitschke). Scale = 0.1 mm and applies to signa only.

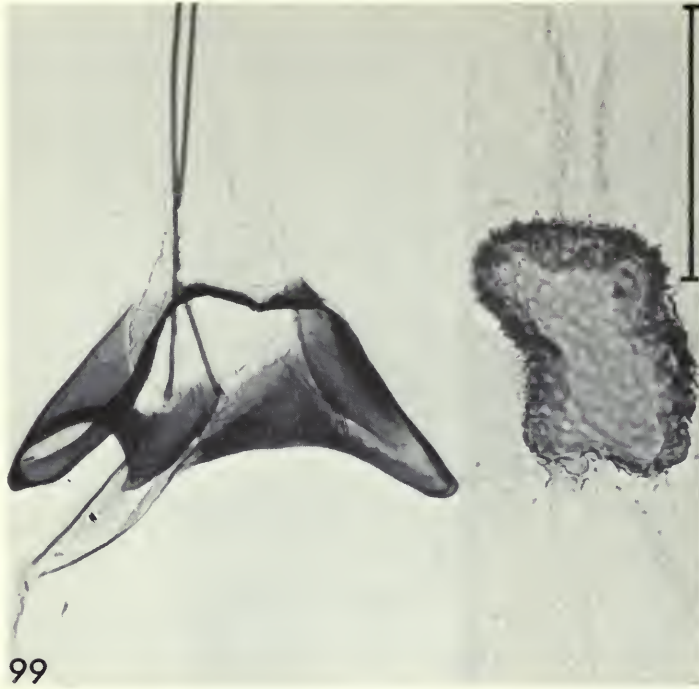

99



100



101



102



103

Figs 99–103 Genitalia of *Mirificarma* ♀. 99, *M. interruptella* (Hübner). 100, *M. burdonella* (Rebel). 101, *M. cabezella* (Chrétien). 102, *M. ulicinella* (Staudinger). 103, *M. mulinella* (Zeller). Scale = 0.1 mm and applies to signa only.

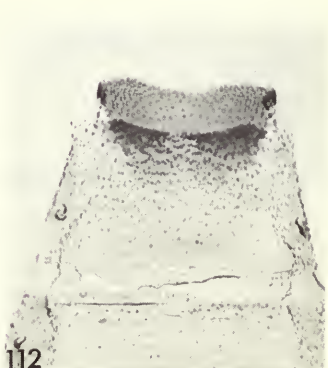
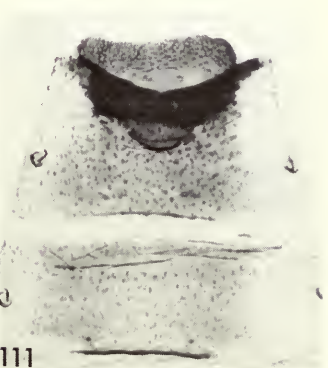
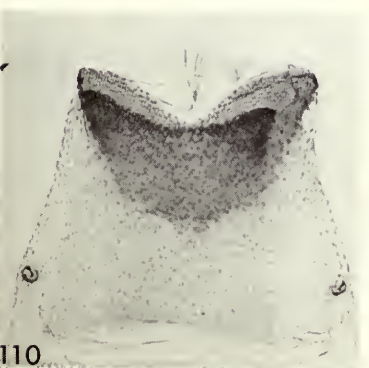
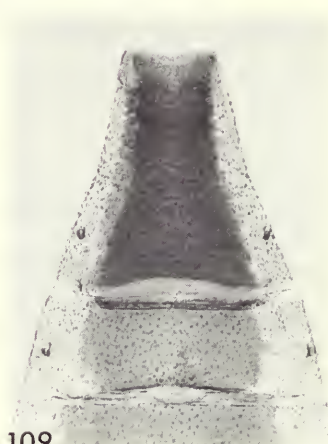
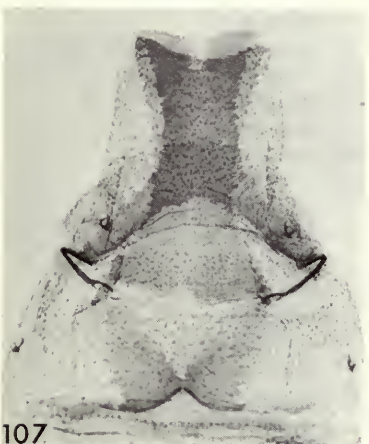

Figs 104–112 Posterior abdominal segments of *Mirificarma* ♀. 104, *M. montivaga* (Walsingham). 105, *M. rhodoptera* (Mann), typical form. 106, *M. rhodoptera* (Mann), small form. 107, *M. pallidipulchra* (Walsingham). 108, *M. aflavella* (Amsel). 109, *M. eburnella* ([Denis & Schiffermüller]). 110, *M. cytisella* (Treitschke). 111, *M. interruptella* (Hübner). 112, *M. burdonella* (Rebel).

Index

Principal references are in **bold**; invalid names are in *italics*.

- Acompsia 5, 15
 affavella 17, 18, 20, 24, **25**,
 26–28
 albicosta 39
 Anacampsinae 3
 Anarsia 3
 Aristoteliinae 3, 6
 aristotelis 3
 Aroga 3, 5
aurantiella 29, 30
- Bryotropha 12
 burdonella 17, 18, 39, **40**, 41,
 42, 44
- cabezella 5, 12, 13, 17, 18, 20,
 21, 33, **41**, 42–44
caminariella 43, 44
 Caryocolum 3
 Chelariinae 3
 Chionodes 3, 6
 Coleophoridae 39
 constricta 12, 17, 19, 20, 21, 32,
33, 42
 cytisella 5, 12, 17, 21, 29, **34**, **36**
- Deltophora 6
 denotata 5, 12, 13, 16, 17, **22**,
 23, 34
 Dichomeriinae 3
 Dichomeris 3, 15
- eburnella 3, 5, 12, 16–18,
 24–26, **27**, 28
- fasciata 11, 15, 16, 18, 24, 29,
 30, **31**, 39
 ferrugella 5, 27
 Filatima 12
flammella 13, 27
 flavella 5, 12, 16, 17, 24, 25, **26**,
 27, 28
- flavonigrella 12, 17, **39**, 40, 41,
 44
 formosella [Denis &
 Schiffermüller] 3, 27, 28
formosella Hübner 5, 27
- Gelechia 3, 5, 6, 9, 13, 15
 Gelechiidae 3, 6, 15
 Gelechiinae 3, 5, 6, 9, 15
 Gelechiini 3, 6, 15
 gibbosella 6, 15
 Gnorimoschemini 6, 15
- Helina* Guenée 13
 Helina Robineau-Desvoidy 13
 hippophaella 6
 Hypatiminae 6
- interrupta* 38, 43
 interruptella 5, 9, 12, 15, 17, 18,
 20, 21, **29**, 31, 32, 38, 39, 43, 44
- lentiginosella 5, 11, 12, 15, 16,
 18, 19, 29, **32**, 33, 45
 leonella 34, 36, **37**
 Lita 3, 5
 lugubrella 3
- maculatella 5, 9, 13, 15–17, **19**,
 20, 22, **23**, 29, 34
 Mirificarma 3, 5, 6, 8, 9, 12, **13**,
 15, 16
 monticolella 17, 19, **37**, 38
 montivaga 5, 6, 9, 11–13,
 15–17, **18**, 19, 20, 24, 38
 mulinella 3, 5, 12, 13, 17, 18, 29,
 32, 39–42, **43**, 44, 45
 myricariella 6
- Neofaculta 5
 Neofriseria 6
 nigra 6, 13
- nigraesilvae* 44
- obscura 32
 ocellinella 11–13, 15, 16, 18, 19,
 22–24, **29**, 30, 31, 38
 Oecophoridae 5, 27
 Ornativalva 3, 15
 Orophia 5, 27
- pallidipulchra 5, 12, 14, 17, 20,
24, 25–28
 Psoricoptera 6, 15
pulverosella 18, 19
- retamaeofoliella* 29, 30
Rhinosia 5
 rhodoptera 9, 12, 15, 16, 18, 19,
 20, 21, 24, 33, 42
 rhombella 6
 roseella 36
rufeiformosella 27
- sabinella 6
 Schiffermuelleria 3, 28
 scissella 12, 13, 16, 17, **20**, 21,
 33, 42
 scotinella 6
segetella 26, 27
 senticetella 6
 solutella 3
strioella 24
 Syncopacma 3
- Teleiodes 6
 Teleiodini 6
- ulicinella 5, 12, 13, 17, 18, **42**,
 43, 44
- vicinella 23
- Xystophora 3

British Museum (Natural History)

Milkweed butterflies: their cladistics and biology

P. R. Ackery & R. I. Vane-Wright

The Danainae, a subfamily of the Nymphalidae, contains only some 150 species, yet aspects of their biology have stimulated far more attention than can be justified by species numbers alone. In recent years, an expansive literature has grown, considering aspects of their courtship and pre-courtship behaviour, migration, larval hostplant associations, mimicry and genetics. The popularity of danaines among biologists can certainly be attributed to this combination, within one small group, of so many of the factors that make butterflies such an interesting group to study. The obvious need to place this wealth of biological data within an acceptable systematic framework provided the impetus for this volume.

Started eight years ago within the conventions of evolution by natural selection, and Hennig's phylogenetic systematics, the book is now largely about natural history (what the insects have and do, where they live and how they develop) and natural groups – as revealed by a form of analysis approaching that practised by the new school of 'transformed cladistics'. The authors have prepared a handbook that will appeal to a wide range of biologists, from museum taxonomists to field ecologists.

1984, 448 pp (approx.), 12 pp colour, 73 b/w plates, line and graphic illustrations, maps, extensive bibliography. ISBN 0 565 00893 5

Titles to be published in Volume 48

Gelechiid moths of the genus *Mirificarma*.

By Linda M. Pitkin.

Macronematine caddisflies of the genus *Amphipsyche* (Trichoptera: Hydropsychidae)

By P. C. Barnard.

A review of the genera of Indo-Pacific Encyrtidae (Hymenoptera: Chalcidoidea).

By John S. Noyes & M. Hayat

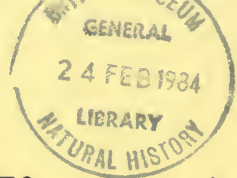

Bulletin of the British Museum (Natural History)

Macronematine caddisflies of the genus
Amphipsyche (Trichoptera:
Hydropsychidae)

P. C. Barnard

Entomology series

Vol 48 No 2

23 February 1984

The *Bulletin of the British Museum (Natural History)*, instituted in 1949, is issued in four scientific series, Botany, Entomology, Geology (incorporating Mineralogy) and Zoology, and an Historical series.

Papers in the *Bulletin* are primarily the results of research carried out on the unique and ever-growing collections of the Museum, both by the scientific staff of the Museum and by specialists from elsewhere who make use of the Museum's resources. Many of the papers are works of reference that will remain indispensable for years to come.

Parts are published at irregular intervals as they become ready, each is complete in itself, available separately, and individually priced. Volumes contain about 300 pages and several volumes may appear within a calendar year. Subscriptions may be placed for one or more of the series on either an Annual or Per Volume basis. Prices vary according to the contents of the individual parts. Orders and enquiries should be sent to:

Publications Sales,
British Museum (Natural History),
Cromwell Road,
London SW7 5BD,
England.

World List abbreviation: *Bull. Br. Mus. nat. Hist.* (Ent.)



© Trustees of the British Museum (Natural History), 1984

The Entomology series is produced under the general editorship of the
Keeper of Entomology: Laurence A. Mound
Assistant Editor: W. Gerald Tremewan

ISBN 0 565 06001 5
ISSN 0524-6431

British Museum (Natural History)
Cromwell Road
London SW7 5BD

Entomology series
Vol 48 No 2 pp 71-130

Issued 23 February 1984

Macronematine caddisflies of the genus *Amphipsyche* (Trichoptera: Hydropsychidae)



P. C. Barnard

Department of Entomology, British Museum (Natural History), Cromwell Road, London SW7 5BD

Contents

Synopsis.....	71
Introduction	71
Abbreviations of depositories	73
Acknowledgements	73
Taxonomic method.....	73
Classification of the Macronematini	74
Key to Old World genera of Macronematini.....	74
<i>Amphipsyche</i> McLachlan	76
Geographical distribution	78
Biology.....	78
Cladistic analysis	80
Check-list of <i>Amphipsyche</i> species	85
Key to species of <i>Amphipsyche</i>	85
The <i>proluta</i> -group	86
The <i>apicalis</i> -group	94
The <i>meridiana</i> -group	101
References	127
Index.....	130

Synopsis

In this revision of the genus *Amphipsyche* McLachlan 22 species are recognized, of which two are described as new. One new generic and ten new specific synonyms are established, and one species is transferred to *Amphipsyche* from *Protomacronema* Ulmer. Eight lectotypes are designated. Keys are given to the Old World genera of the tribe Macronematini and to the species of *Amphipsyche*. The classification of the species is based on a cladistic analysis, and some of the evolutionary and zoogeographical implications of the analysis are discussed.

Introduction

Amphipsyche McLachlan is an Old World genus of caddisflies having net-spinning larvae that are frequently found in fast freshwater streams throughout the Afrotropical and Oriental regions. Some species have figured prominently in recent freshwater pollution and impoundment studies, and at least one species is a predator on larvae of *Simulium* Latreille (Diptera).

Many of the recent ecological studies on tropical freshwater habitats are the result of the pressing need for knowledge of the effects of man's activities, the most obvious of which is direct pollution of the water by chemical or other agents. Although most Trichoptera are very sensitive to such pollutants and tend to disappear even at low levels of contamination, there is a selective response shown by different species of caddis. Resh & Unzicker (1975) have stressed that it is important to be able to identify the organisms at the specific level for this kind of study. Another important influence of man is the damming of rivers for hydroelectric or irrigation schemes. Although the ecology of such impounded water is usually studied, the effects on the regulated river itself are less well known and the few existing reports suggest that the natural watercourse may be altered for a considerable distance downstream of the impoundment. The release of

water rich in zooplankton from these dams leads to large populations of filter-feeding organisms such as Hydropsychidae, and among these *Amphipsyche* has often been reported as reaching pest proportions. However, it should be noted that the discharge of cold hypolimnial water from dams can suppress the populations of such organisms immediately below the impoundment (Stanford & Ward, 1981). *Simulium*, another filter-feeder, can also occur in large numbers in such habitats, and various insecticides such as DDT have been used to control populations of the *S. damnosum* complex, the vector of onchocerciasis. The effects of these control agents on non-target organisms is always monitored, and because *Amphipsyche* occurs at similar sites it has often figured prominently in such studies (Corbet, 1958a; Statzner, 1981). *Amphipsyche scottae* is also known to be a predator of *Simulium* (Chutter, 1968).

The identification of the organisms collected in all such freshwater studies, especially in the tropics, is always a major problem. Scott (1975) stated that the larval stages of less than 15 per cent of the African Trichoptera were known, and the corresponding figure for Asia must be considerably lower. Such identification relies on the correct association of larvae and adults, which often depends on long-term collecting programmes and rearing in the field; equally important is the provision of reliable keys for the identification of adults. The net-spinning larvae of the Hydropsychidae are often one of the most abundant groups of macro-invertebrates in running water, and as part of a continuing study of the subfamily Macronematinae this paper deals with the adults of the genus *Amphipsyche*, in the tribe Macronematini. The species in this genus are superficially very similar to each other, and they also resemble species of *Aethaloptera* Brauer, in the Polymorphanisini (Barnard, 1980); I have frequently found these two genera confused in collections. Ulmer's (1907) monograph of the subfamily is still useful for some genera such as *Macronema* Pictet, but not for *Amphipsyche*; of the 22 species currently recognized only two were known to Ulmer. Kimmins (1962; 1963) described several African species, but new characters have been discovered in some of these.

The keys here provided to the Old World genera of Macronematini, and to the species of *Amphipsyche*, are based on external characters as far as possible, but several species are known only from males and critical examination of the genitalia is often necessary. Using a cladistic analysis of the species of *Amphipsyche* the genus is divided into three main species-groups. Some of the evolutionary and zoogeographical implications of this classification are discussed, and it is intended to apply this approach to other genera of the Macronematinae and ultimately to test the current generic and tribal groupings within the whole subfamily.

The methods of preparation and drawing of specimens are virtually the same as in the revision of the Polymorphanisini (Barnard, 1980). Temporary glycerine preparations of male and female genitalia were used for examination, and denuded wings were drawn from dry-mounted slide preparations wherever possible.

The scale lines on the figures represent the following lengths: wings 1.0 mm; maxillary palps 0.25 mm; legs 0.5 mm; genitalia 0.25 mm. All other features illustrated have their scale indicated on the figure. The arrows on some figures indicate features referred to in the keys or in the species descriptions.

The nomenclature of wing veins and genitalia components follows Schmid's (1980) broadly based study. This means that some of the names previously used in the Polymorphanisini revision are now changed. Thus the aedeagus is here termed the phallosheca, and the gonopods are now called the inferior appendages. The wing venation terminology is unchanged, except that the apical forks are labelled I to V. Thus fork R_2 is now fork I, fork R_4 is fork II, fork M_1 is fork III, fork M_3 is fork IV, and fork Cu_{1a} is fork V. These forks are the same in both the fore and hind wing (except that fork IV never occurs in the hind wing of Trichoptera).

No attempt has been made to homologize the endotheal spines of *Amphipsyche* males with those seen in some other genera. They are thus given the arbitrary names of dorsal, mid and ventral spines, according to their level of insertion on the apex of the phallosheca. The phallocrypt pocket may be homologous with the similar structure seen in some other families of Trichoptera (Nielsen, 1957), but its ontogeny is unknown.

Under the heading 'Material examined' for each species are listed only the total numbers of

each sex, the countries of collection and institutions holding the material. Full collection data are given only for type-specimens. Where there is further information on the distribution of a species which is not apparent from the list of material examined, this is noted in the corresponding 'Remarks' section.

Abbreviations of depositories

BMNH	British Museum (Natural History), London, U.K.
IP	Institut für Pflanzenschutzforschung, Eberswalde, D.D.R.
IRSNB	Institut Royal des Sciences Naturelles de Belgique, Brussels, Belgium
MCZ	Museum of Comparative Zoology, Harvard University, U.S.A.
MNHN	Muséum National d'Histoire Naturelle, Paris, France
MNHU	Museum für Naturkunde der Humboldt-Universität, Berlin, D.D.R.
MRAC	Musée Royal de l'Afrique Centrale, Tervuren, Belgium
NAC	Nanjing Agricultural College, Nanjing, China
NM	Naturhistorisches Museum, Vienna, Austria
RNH	Rijksmuseum van Natuurlijke Historie, Leiden, The Netherlands
RSM	Royal Scottish Museum, Edinburgh, U.K.
USNM	National Museum of Natural History, Smithsonian Institution, Washington D.C., U.S.A.
ZI	Zoological Institute, Lund, Sweden
ZM	Zoologisches Museum, Hamburg, B.R.D.
ZSI	Zoological Survey of India, Calcutta, India

Acknowledgements

I am very grateful to the following for the loan of specimens: Mr R. Danielsson, ZI; Dr J. Decelle, MRAC; Dr O. S. Flint, Jr, USNM; Dr D. C. Geijskes and Dr P. H. van Doesburg, RNH; Dr A. Kaltenbach, NM; Dr J. Legrand, MNHN; Dr G. Marlier, IRSNB; Mr A. F. Newton, MCZ; Prof. Dr H. Strümpel, ZM; Prof. Tian Li-xin, NAC; Frau H. Wendt, MNHU. I also thank the following for information: Dr S. K. Ghosh, ZSI; Åke Lilliestam, Kungliga Biblioteket, Stockholm; Dr Bo Tjeder, ZI; the Director, IP. Dr K. M. F. Scott kindly sent me the manuscript of the *Amphipsyche* section of her paper on the Hydropsychidae of southern Africa.

Taxonomic method

Although the cladistic method of classification is often taken to be equivalent to Hennig's (1966) phylogenetic systematics, Platnick (1979) has pointed out that there is no necessary connection between cladistics and the process of evolution: a cladogram can be constructed simply by studying the pattern of the distribution of characters in a group of organisms. Although this 'transformed' cladistic approach has been criticized by several authors (e.g. Beatty, 1982) on the grounds that the claimed evolutionary neutrality is actually counter-productive, Platnick argued that cladistic methods are simply attempts to discover natural groups by analysing their characters, which is surely the aim of taxonomy in general.

One of the difficulties with Hennig's phylogenetic method is that the taxonomist has to make *a priori* decisions about the polarity of character states, and to sort them into apomorphies and plesiomorphies on the basis of outgroup comparisons. This is a crucial step in the construction of a phylogeny, because groups can be recognized only on the basis of synapomorphies. Inevitably, some of these decisions on the polarity of character states are very hard to make, because the taxonomist has to assume at least some of the evolutionary history of the group before he starts. There is thus an element of circularity in the process, because one cannot make such assumptions about characters used to produce a phylogeny, and then use that phylogeny to draw independent conclusions about the evolution of the group. Platnick (1979) argued that the 'plesiomorphic' state of a character is really the more general one, in that it is found in more

groups than the 'apomorphic', or less general, state. The group possessing the more specialized character state is therefore contained within the group showing the more general state, and this gives rise to the nested sets and subsets which form the hierarchical classification. This is an important concept, in that it avoids the idea that plesiomorphic and apomorphic states are alternatives: it also clearly shows why a group based on plesiomorphies alone cannot be a natural one because it would be recognized only by the absence of characters. Thus the production of a cladogram does not depend on the reconstruction of the evolutionary history of the group, but on the differentiation of more general characters from less general ones. The hierarchical structure of the cladogram is therefore a result of the inter-nested sets of unique characters, each delimiting a natural group.

The test of whether the taxonomist has correctly identified the level of generality of a character is whether or not it is congruent with other characters at higher and lower levels. Instead of making decisions about the polarity of character states, one has only to distinguish the presence of a character from its absence, the latter being hypothesized as the more general condition. This highlights the problem of using the loss of a character to delimit a group. Phylogeneticists would decide that a loss character may be apomorphic by *a priori* outgroup reasoning, whereas transformed cladists would discover the level of generality of the 'loss' by its congruence with all the other characters examined. In practice, however, it is preferable to use presence characters to recognize groups, because without ontogenetic data it is hard to distinguish the secondary loss of a character from its absence at a more general level, unless there is a high degree of congruence.

Having produced a cladistic classification without any assumptions of evolutionary history or speciation mechanisms, the taxonomist is then free to use the cladogram to infer something about the evolution of the group being studied, by hypothesizing a phylogenetic tree. Following the cladistic analysis of *Amphipsyche* I therefore discuss some of the phylogenetic and zoogeographic implications of the cladogram. The use of the transformed cladistic method and its application in biogeography are discussed in detail by Nelson & Platnick (1981).

Classification of the Macronematini

The current classification of the subfamily Macronematinae was discussed in a previous paper (Barnard, 1980). Of the two constituent tribes, the Polymorphanisini is almost certainly monophyletic, despite being delimited by loss characters. The adults are recognized by the loss of the mouthparts, and the larvae by the loss of the stridulatory organs on the head and fore legs (Scott, 1975). However, the tribe Macronematini lacks any diagnostic characters and is probably not monophyletic, although certain generic groups can be distinguished within it. For example, *Macrostemum* Kolenati, *Amphipsyche* and *Protomacronema* Ulmer can be grouped on both adult and larval characters (Scott, 1975), the most noticeable larval character being the raised carina on the head. The Neotropical genus *Blepharopus* Kolenati probably belongs here too (Flint & Wallace, 1980) although the carina is only poorly developed. On the other hand, the larvae of *Leptonema* Guérin-Ménéville and *Macronema* s.str. (Flint & Bueno Soria, 1982) have no carina, but *Leptonema* and *Macrostemum* adults are often very similar superficially. More study is needed to clarify the validity of this tribe, but the group is retained here for convenience.

Key to Old World genera of Macronematini

- | | | |
|-------|---|-----------------------------------|
| 1 | Discoidal cell present in fore wing, but sometimes very small (Fig. 1) | 2 |
| - | Discoidal cell absent in fore wing (Fig. 3) | 5 |
| 2 (1) | R_1 in hind wing ends on R_{2+3} , joined to <i>Sc</i> by short cross-vein (Fig. 9) | 3 |
| - | R_1 in hind wing fuses with <i>Sc</i> (Fig. 8) | 4 |
| 3 (2) | In fore wing, base of <i>Rs</i> entire (Fig. 1) | PSEUDOLEPTONEMA Mosely |
| - | In fore wing, base of <i>Rs</i> obsolete, joined to R_1 by cross-vein (Fig. 2) | TRICHOMACRONEMA Schmid |
| 4 (2) | Maxillary palp with second segment longer than third (Fig. 4) | LEPTONEMA Guérin-Ménéville |

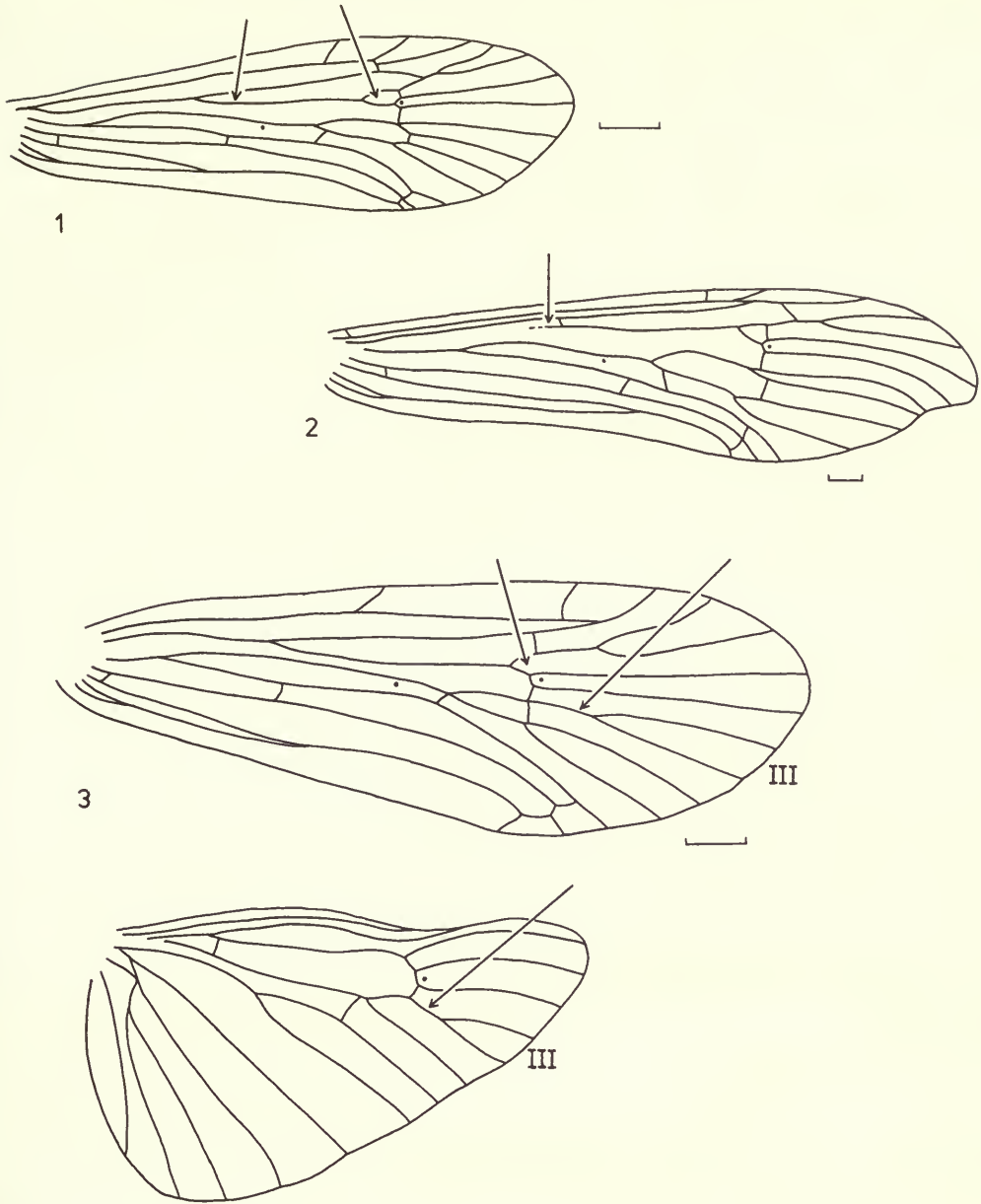

Figs 1-3 1, *Pseudoleptonema* sp. ♂, fore wing; 2, *Trichomacronema* sp. ♂, fore wing; 3, *Leptopsyche gracilis* McLachlan ♂, fore and hind wings.

- Maxillary palp with third segment longer than second (Fig. 5)..... **MACROSTEMUM** Kolenati
- 5 (1) Fork III in both wings with stalk (Fig. 3) **LEPTOPSYCHE** McLachlan
- Fork III in both wings sessile (Figs 6, 7) 6
- 6 (5) ♂: anal area of fore wing strongly dilated (Fig. 12); ♀: Sc in hind wing ends on costal margin (Fig. 18) **AMPHIPSYCHE** McLachlan
- ♂: anal area of fore wing not dilated (Fig. 6); ♀: Sc in hind wing fuses with R₁ to end on R₂₊₃ (Fig. 7) **PROTOMACRONEMA** Ulmer

AMPHIPSYCHE McLachlan

Amphipsyche McLachlan, 1872: 68. Type-species: *Amphipsyche proluta* McLachlan, by monotypy.
Phanostoma Brauer, 1875: 69. Type-species: *Phanostoma senegalense* Brauer, by monotypy. [Synonymized by Martynov, 1935: 201.]
Amphipsychella Martynov, 1935: 201. Type-species: *Amphipsychella extrema* Martynov, by original designation and monotypy. **Syn. n.**

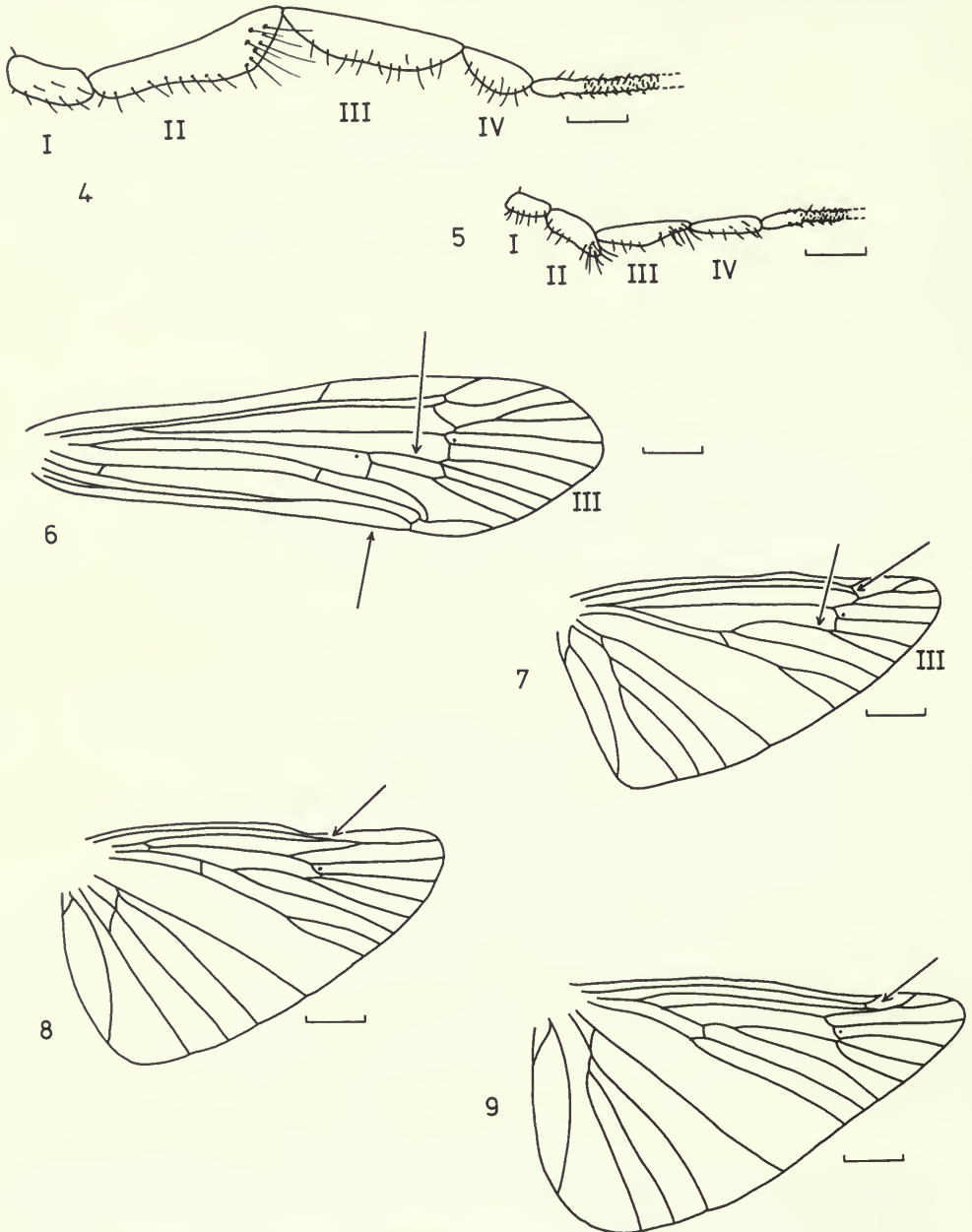

Figs 4-9 4, *Leptonema* sp., maxillary palp; 5, *Macrostemum* sp., maxillary palp; 6, *Protomacronema* sp. ♂, fore wing; 7, *Protomacronema* sp. ♀, hind wing; 8, *Macrostemum* sp. ♂, hind wing; 9, *Pseudoleptonema* sp. ♂, hind wing.

Small to medium sized species, wing length ♂ 8–20 mm, ♀ 6–15 mm, yellowish or brownish in colour, rarely with markings on head or thorax. Antenna up to three and a half times wing length in ♂, up to twice wing length in ♀; flagellar segments numerous (75–100 in ♂, 45–70 in ♀), always elongate. Head with two pairs of setigerous warts in ♂, hind pair indistinct, only one pair in ♀; genae in *apicalis*-group flat, with silverish pubescence. Maxillary palp with fifth segment usually very long and secondarily articulated, but sometimes reduced or even entirely fused with fourth segment. Spur formula basically 1.4.4, but often reduced to 0.4.4, 0.4.3, 0.4.2, 0.3.2 or 0.2.2. Tibia and tarsus of mid leg broad and flat in ♀. Wing-coupling mechanism consists of single row of curved macrotrichia on costal margin of hind wing, engaging on anal fold of fore wing (Fig. 10). Discoidal cell absent in fore and hind wings ('false' discoidal cell formed by secondary fusion of R_4 and R_5 in fore wing of *apicalis*); median cell present in fore wing, usually absent in hind wing (present in *magna*). In fore wing R_1 and R_s often sinuous near anastomosis; fork I always stalked, fork II usually sessile, but stalked in *apicalis*-group. *Sc* in hind wing ends on costal margin, joined to R_1 by cross-vein. ♂ fore wing with strong dilated anal area.

♂ genitalia with elongate two-segmented inferior appendages; phallocrypt pocket, associated with base of inferior appendages, and pre-anal appendages present in *proluta*-group only. Phallosome usually with broad base, narrow stem and bulbous apex, with up to three pairs of endothelial spines. ♀ eighth sternite partially divided into two sclerites.

REMARKS. Within the Macronematini, *Amphipsyche* seems most closely related to the African genus *Protomacronema*. Both genera have a very similar wing venation, although *Protomacronema* males do not have the dilated anal margin of the fore wing seen in *Amphipsyche*, and in the female hind wing *Sc* fuses with R_1 to end on R_{2+3} , instead of ending on the costal margin. The male genitalia are also superficially similar, *Protomacronema* having a pair of endothelial spines similar to those in the African species of *Amphipsyche*, but a detailed study of *Protomacronema* is needed in order to clarify the relationships of these two genera.

Amphipsyche and *Phanostoma* Brauer have always been considered as being closely related, and have usually been separated on the spur formula. Martynov (1935: 201) synonymized them on the grounds that the species within *Amphipsyche* showed such variation in the number of spurs that the two genera were essentially the same. This was not accepted by all later authors (e.g. Ulmer, 1951) but eventually Kimmins (1962) showed that the spur formula of *A. senegalensis* (the type-species of *Phanostoma*) had been wrongly described, and that the distinction between the genera could no longer be maintained. *Phanostoma* is available as a subgeneric name for the *meridiana*-group recognized in the current study, but such a formal subdivision of the genus does not seem necessary. Kimmins also suspected that *Amphipsychella* Martynov was a synonym of *Amphipsyche*, and although I have seen no specimens of *A. extrema*, I am confident that this synonymy is correct.

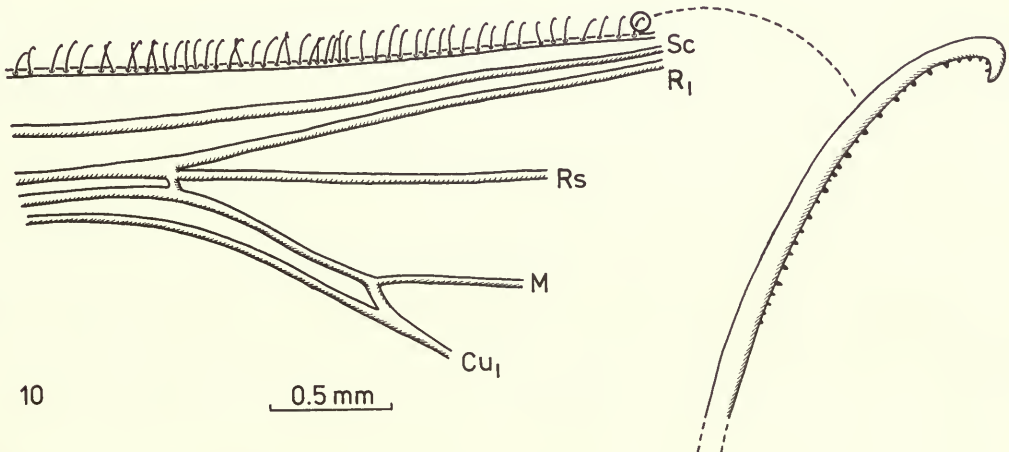

Fig. 10 *Amphipsyche bernerii* ♂, wing coupling mechanism on costa of hind wing.

Geographical distribution

Most species of *Amphipsyche* are restricted to the Old World tropics. The *meridiana*-group has representatives throughout the Afrotropical region, Madagascar, India and Sri Lanka, and through mainland South East Asia to Java, Borneo and the Philippines. The *apicalis*-group is restricted to S. India, Burma, Thailand, Vietnam, West Malaysia, Sumatra and Borneo, and the *proluta*-group occurs only in India, China and the Amur region of the U.S.S.R. Some zoogeographical implications of these distributions are discussed below (p. 84).

A. senegalensis is the most widespread African species, being found throughout almost the whole of the Afrotropical region, whereas the other African species have very restricted distributions (Fig. 119). Similarly, *meridiana* is a very widespread species throughout India, Sri Lanka and South East Asia as far east as Java, although this distribution is apparently disjunct (Fig. 104). Most of the other species in the *meridiana*-group, and in the other groups, have more restricted distributions. The unique occurrence of *proluta* in central and northern China northwards to the Amur region of the U.S.S.R. shows an interesting parallel with *Aethaloptera evanescens* (McLachlan) in the Polymorphansini (Barnard, 1980). There is a third species in the Macronematinae, *Macrostemum radiatum* (McLachlan), with a similar distribution, although this species extends into Siberia (like *A. evanescens*) and also occurs in Japan.

Biology

The first account of the immature stages of a species of *Amphipsyche* was by Hafiz (1937), who described the larva and pupa of *meridiana* (as *indica*) from material collected near Calcutta. Ulmer (1957) gave detailed descriptions of Javan and Sumatran larvae and pupae of *meridiana*, but these vary in some features from Hafiz' account. Hafiz described the larval head as being uniformly dark brown, whereas Ulmer described (and figured) a pair of yellow flecks extending from the eyes onto the frontoclypeus. I have examined larvae recently collected from Java and they match Ulmer's figures of the head markings, so this feature may represent a genuine difference between the populations in India and Indonesia. The two descriptions also vary in the gill formula (allowing for the fact that the two authors used slightly different terminology for some gills) but here the recently collected Javan material matched exactly Hafiz' description of Indian specimens. Further information is needed to determine whether this species is polymorphic or whether the two populations are perhaps subspecifically distinct.

The larva of *A. proluta* was described by Lepneva (1947: redescribed, 1970). Despite the two species being in different species-groups it is apparent that the larvae of *meridiana* and *proluta* resemble each other very closely, the main difference being that in *proluta* the yellow head markings fuse to form a continuous transverse band. The gill formula of *proluta* matches that of the recently collected specimens of *meridiana* from Java.

The larva of the African species *senegalensis* was first described from Ugandan material by Hickin (1955). Jacquemart (1957) gave a further detailed account of this species from Lake Edward (Zaire), but it should be noted that in his description the legends (and numbers) of the figures of the prothorax and mesothorax have been transposed, and the metathorax is figured upside-down. Ulmer (1963) described his Egyptian larval material as *curvinerve*, here considered a synonym of *senegalensis*. Ulmer's description seems to differ slightly from those of Hickin and Jacquemart, but he made no direct comparisons with these earlier accounts, and without seeing material from these different areas one cannot draw any conclusions. Ulmer gave the gill formula for his 'curvinerve' specimens, which is quite different from those of *meridiana* and *proluta*, but as neither Hickin nor Jacquemart described the gills of *senegalensis*, further comparison is impossible. Moreover, Ulmer's specimens may have represented *ulmeri* Kimmins, and not 'curvinerve'. The pupa of *senegalensis* was first figured and briefly described by Gibbs (1973), with a detailed description by Marlier (1978). Several aspects of the biology of *A. scottae* have been described in papers by Chutter and Scott (see below) and a full description of the larva appears in Scott (in press).

Although the larvae of only these few species have been described in any detail, there is sufficient in common between them to recognize some generic characters. This has been done by

Lepneva (1970), Gibbs (1973) and Scott (1975; in press), all of whom give characters sufficient to distinguish *Amphipsyche* larvae from those of other macronematine genera, especially *Macrosotemum* (as *Macronema*), *Leptonema* and *Protomacronema*. Scott (1975) has demonstrated that the larvae of *Protomacronema* and *Amphipsyche* seem to show a close relationship between these two genera, thus confirming the evidence suggested by the adult characters (see 'Remarks' p. 77).

Ulmer (1957) separated the larvae of *Amphipsyche* and *Phanostoma* on the form of the hind tarsal claw. This was described as half the length of the tarsus and pointed in *Amphipsyche meridiana*, and only one-third the tarsal length and blunt in *Phanostoma*. This character was later figured in '*Phanostoma curvinerve*' (Ulmer, 1963). However, if Hickin's (1955) and Jacquemart's (1957) figures of *senegalensis* are accurate, the claw is also half the tarsal length and pointed in this species. It is possible that the short, blunt claw in Ulmer's specimens is due to excessive abrasion on a rocky substrate (which is known to affect both the anal and tarsal claws in other species of Trichoptera).

Habitats

Larvae of *Amphipsyche* are generally found in fast-flowing rivers on a stony substrate. Hickin (1955) also recorded *A. senegalensis* in Lake Victoria, but the larvae were near the outfall of the Nile and were therefore still in fast water. Scott (1970) found the same species in Lake Kariba, in a deep bay at the mouth of a stream, and Seshadri (1955) described the mass occurrence of *A. meridiana* in the very rapid water near the sluice gates of a reservoir.

Chutter (1963) described the ecological requirements of *A. scottae* in some detail. The species was found on the Vaal River in South Africa, immediately below the man-made Vaal Barrage. Here the larval population dropped in winter and built up again in September–November, presumably in direct response to the increase in zooplankton populations, although some larvae were present all the year round. Further down the same river Chutter (1968) found that most adults of this species were caught in January, when the larval populations were again low. The gut contents of some larvae showed that they are apparently omnivorous, feeding on algae as well as on insects such as *Simulium* larvae.

Boon (1979) discovered populations of *A. meridiana* below the artificial Lake Rawapening on the River Tuntang in central Java. Many organisms have difficulty in living in such a regulated river which is subject to sudden large changes in both water level and current speed. Parts of the substrate of this river are formed from vesicular volcanic lava, and large numbers of *meridiana* larvae live in the vesicles in the rock. Boon has suggested four advantages of this habitat: (1) the spacing of the vesicles enforces the spacing of the larvae, both within the same species and between the other two hydropsychid species in the same river, thus preventing overcrowding; (2) the fairly deep vesicles give protection against predation; (3) the larvae are protected from being dislodged during high water levels; (4) they are protected from desiccation during low water levels. Moreover, *meridiana* larvae also construct very tough feeding nets, which are more resistant to damage than those of most Hydropsychidae and also do not collapse in low current speeds or even when exposed at low water. Boon also showed that larvae apparently co-operate in building large communal nets, which is unusual in this family. It therefore seems that *meridiana* is a particularly adaptable species, and this may be linked to its widespread distribution through India, South East Asia and Indonesia. The fact that *senegalensis* has been found in both rivers and lakes (albeit always in fast water) suggests that it too may be an adaptable species, possibly accounting for its widespread Afrotropical distribution.

Corbet (1958a) studied the fauna of the Victoria Nile below the Owen Falls Dam, subsequent to the use of DDT to eliminate populations of the *Simulium damnosum* complex in an effort to control onchocerciasis. Trichoptera in general are very sensitive to DDT, and the previously large populations of *A. senegalensis* disappeared entirely from the treated stretch of river immediately after the addition of the insecticide. Over a year later the populations of *senegalensis* were still very small, despite the chance of recolonization from unaffected popula-

tions immediately upstream. Corbet showed that this kind of insecticidal treatment can have long-term effects on many such macroinvertebrates as well as on the fish which rely on them for food.

'Pest' species

Where *Amphipsyche* larvae have colonized the fast, zooplankton-rich water immediately below man-made reservoirs and impoundments, either the larvae or the adults have sometimes reached 'pest' proportions. Seshadri (1955) gave an account of *meridiana* larvae occurring below the sluice gates of a reservoir in India. Here the adults were the problem, flying in enormous numbers every night between September and November, swarming around the street-lights and causing a great nuisance to people living nearby. Seshadri vividly describes how 'By about 8 P.M. it was a remarkable sight to see these insects in their millions dashing against lamps, and dropping to the ground so as to cause considerable annoyance to passers-by and vehicles. This went on throughout the night and every morning, to the Town Sanitary Staff fell the task of cleaning up the streets and removing basket loads of dead insects, especially from under the fluorescent lamps, where they formed shallow heaps several inches thick and many square feet in extent.' The larval nets were found encrusting the rocks for a few hundred yards downstream of the sluice gates and at times of low water the decaying stranded larvae were 'emanating a foul stench all over the entire locality'. Hickin (1955) described the 'peculiar sickly odour' of the dead bodies of vast numbers of adults of *senegalensis* which, together with a species of *Cheumatopsyche* Wallengren, had been swarming around a light at the Ripon Falls, Lake Victoria. Adults of *senegalensis*, together with a mayfly, were the main insect nuisance at the lights of the Owen Falls Dam (Uganda) according to Corbet (1958a), and he also (1958b) reported that larvae of *senegalensis* and two *Cheumatopsyche* species occasionally occurred in such numbers as to obstruct filters in the same dam.

Flight activity

The flight period of *Amphipsyche* species, like that of most Trichoptera, is virtually continuous in the tropics, but more noticeably seasonal in the more temperate regions. For example, *A. meridiana* adults are found in virtually every month of the year, whereas *scottae* adults, in South Africa, have been captured mainly from December to March.

Corbet & Tjønneland (1955) studied the flight activity of different species of Trichoptera throughout the night. The general pattern was of two peaks, one at dusk and one at dawn, although not every species exhibited both peaks of activity. *A. senegalensis* was exceptional in flying throughout the night, with no recognizable peaks; this species also flies in daylight. Only females of *senegalensis* were caught, which led Corbet (1966) to postulate that this species may be parthenogenetic. However, light-trap catches often show abnormal sex ratios because of differential attraction to light, and the material examined in the present study contains appreciable numbers of males of this species, many caught at light. Corbet's claim therefore seems unjustified, although facultative parthenogenesis cannot be ruled out.

Cladistic analysis

The list of characters used in the analysis is given below, grouped under broad morphological divisions. They are all 'presence' characters (see p. 74) and the state of the absence of the character is given in parentheses after each one. In the data matrix (Table 1) their presence is indicated by a plus sign and their absence by a dash, and the order of characters is re-arranged to show how the groupings were constructed to produce the cladogram (Fig. 11). Two apomorphic loss characters could have been used in this analysis, but are unnecessary. The *meridiana*-group can be recognized by the loss of the fore tibial spurs and by the hind spurs being reduced to two or three. The spur formula of 1.4.4 in the *proluta*- and *apicalis*-groups is demonstrably plesiomorphic for the genus (by outgroup comparison with the other genera in the tribe) but the presence of character 21 is sufficient to distinguish the *meridiana*-group, making such phylogenetic reasoning unnecessary. The list of characters used is as follows.

Head

- 1 Vertex with dark brown markings (no markings)
- 2 Genae flat with silverish pubescence (rounded with no pubescence)
- 3 Fifth segment of maxillary palp simple (annulated)
- 4 Fourth and fifth segments of maxillary palp fused (separate)

Thorax

- 5 Mesoscutellum with pair of dark markings (no markings)

Fore wing

- 6 Anal margin dilated in male (margin straight)
- 7 Fork II stalked (sessile)
- 8 'False' discoidal cell present (absent)
- 9 Fork I with dark marking (no marking)
- 10 Series of dark spots at wing apex (no spots at apex)
- 11 Sc-R₁ cross-vein with dark marking (no marking)
- 12 Diagonal marking proximal to anastomosis (no marking)

Hind wing

- 13 M₃₊₄-Cu_{1a} cross-vein present (absent)

Male genitalia

- 14 Ninth segment with lateral row of setae (only dorsal row present)
- 15 Phallocrypt pocket present (absent)
- 16 Basal segment of inferior appendage broad distally (narrow distally)
- 17 Basal segment of inferior appendage entirely broad (entirely narrow)
- 18 Inferior appendage with median setigerous projection on inner side (no setigerous projection)
- 19 Ventral apex of phallosome produced (apex rounded)
- 20 Ventral apex of phallosome pointed (apex rounded)
- 21 Phallosome with ventral median groove meeting gonopore (no groove)
- 22 Eversible endosoma present (no endosoma)
- 23 Base of phallosome flattened dorso-ventrally (base rounded)
- 24 Base of phallosome extended into two pointed lobes (base rounded)
- 25 Base of phallosome broadly triangular (base rounded)
- 26 Stem of phallosome thickened in lateral view (stem narrow)
- 27 Ventral endosomal spines present (absent)
- 28 Mid endosomal spines present (absent)
- 29 Dorsal endosomal spines present (absent)
- 30 Dorsal leaf-like lobes on phallosome (lobes absent)
- 31 Mid endosomal spines blunt, rod-like (spines pointed)
- 32 Mid endosomal spines very long and thickened (spines short and narrow)
- 33 Mid endosomal spines fused (spines paired)
- 34 Mid endosomal spines sharply up-turned (spines straight or only slightly curved)

Three species were not included in the cladistic analysis. *A. bengalensis* and *extrema* were omitted because I was unable to examine material, and *delicata* because males of this species are unknown (male genitalic characters constitute over half the characters used in the analysis). *A. bengalensis* and *extrema* belong to the *meridiana*-group on the basis of their spur formulae (that of *bengalensis* probably being wrongly quoted – see p. 112). The male genitalia of *bengalensis*, which seem to have only the mid endosomal spines present, modified into blunt rods, also place the species in this group, presumably near to *sinhala*. Little can be surmised about *extrema* as it is known only from Martynov's figures of the female, but the highly reduced spur formula and shortened maxillary palps would suggest that it may also be closely related to *sinhala*. Although specimens of *delicata* have been examined, the affinities of the species are doubtful as it possesses none of the non-genitalic characters used in the analysis; it also has the intermediate spur formula of 0.4.4. I suspect that it belongs in the *proluta*-group; it cannot belong in the *apicalis*-group because it lacks characters 2, 7 and 9, and its Chinese distribution makes its inclusion in the *meridiana*-group unlikely, though not impossible.

Incongruencies in the cladogram

Although the cladogram shown is the most parsimonious one that can be constructed from the available data, there are a number of apparent incongruencies in the data matrix (Table 1) to which attention is drawn. Character 11 delimits a distinct group of African species (Fig. 11) but this wing-marking also occurs in *senegalensis* and *exsiliens*. However, its appearance in *senegalensis* is not consistent, and in *exsiliens* it is part of the broader stripe across the anastomosis. Character 19, the produced ventral apex of the phallosome, delimits a large section of the *meridiana*-group, and also occurs in *apicalis*, but the phallosome of this species is different in all other respects. Character 30, the presence of leaf-like lobes on the phallosome, occurs in both *meridiana* and *gratiosa*, but each lobe in *gratiosa* is distinctive in bearing a spine at its tip. Thus each of these apparent incongruencies probably arises from the non-homology of the character, and no real doubt is cast on the validity of the groups suggested by the cladogram.

Character 13, the $M_{3+4}-Cu_{1a}$ cross-vein in the hind wing, occurs independently in *instabilis* and *proluta*, and can thus be considered convergent for these two species.

The remaining three incongruencies are of more interest in that they may highlight some real difficulties. Character 14, the presence of a row of lateral setae on the ninth abdominal segment of the male, is used to combine the *proluta*- and *apicalis*-groups. However, the character is absent in *gratiosa* and *distincta*, yet it occurs independently in *pellucida* of the *meridiana*-group. Only the discovery of further characters at the same level of generality can test the validity of this

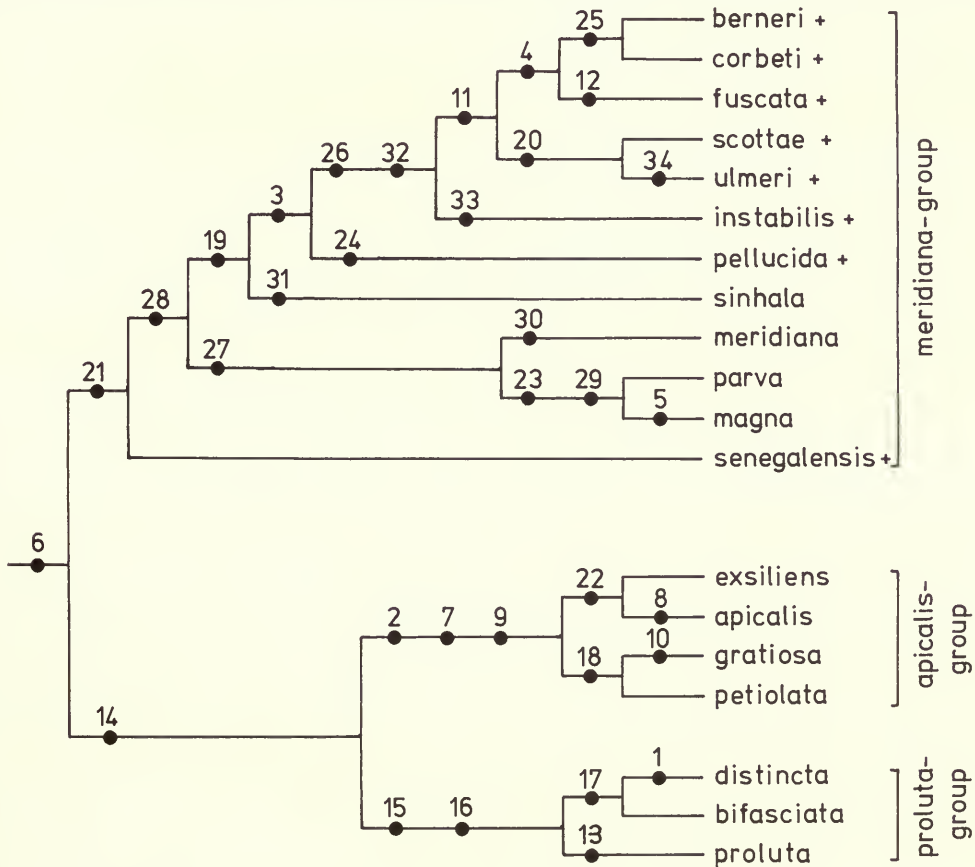

11

+ African spp.

Fig. 11 Cladogram of *Amphipsyche* species.

group. Character 4, the fusion of the 4th and 5th segments of the maxillary palp, delimits the *berneri*-*corbeti*-*fuscata* subgroup, yet this character is also seen in *instabilis*. Similarly, character 3, the lack of secondary articulation on the 5th segment of the maxillary palp, appears to delimit the 'African' subgroup of the *meridiana*-group (excluding *senegalensis*); however, this character does not occur in *ulmeri* but is seen in *magna*. Again, these incongruencies may indicate incorrect groupings in the cladogram, or else possible homoplasy; it seems reasonable to suggest that character 4 in *instabilis* and character 3 in *magna* have each arisen independently, as this tendency for simplification and reduction of the maxillary palps is well known in other genera of the Macronematinae.

Thus there is still scope for further testing of the groups hypothesized in the cladogram, and the discovery of more characters, perhaps in the larvae, is needed to confirm or modify these groupings. Such extra data will show whether the incongruencies arise from non-homology of a character, from the usage of the character at the wrong level of generality, or whether homoplasy can be demonstrated in this genus.

It will be noted that several of the individual species do not have autapomorphies indicated on the cladogram. All of these species are easily recognized, as is demonstrated in the key to species, but they do not have easily described unique features which will differentiate them from all other species in the genus rather than merely from their nearest neighbour. Thus *berneri* and *corbeti* can be distinguished from each other by the lobes of the male tenth segment, which are broad and divergent in *berneri* but narrow and sub-parallel in *corbeti*. Neither of these character states would distinguish one or other species from all others in the genus, and their use would generate confusion and repetition in the cladogram.

Evolutionary and zoogeographical considerations

The geographical distributions of the main species-groups and some of their components have been outlined earlier (p. 78). In brief, the three species-groups have noticeably different distributions, although all three overlap to some degree. It is interesting to try and deduce something of the evolutionary history of the genus from these data, coupled with the information from the cladogram (Fig. 11). For these purposes the cladogram can be considered as a phylogram, showing degrees of common ancestry (Nelson & Platnick, 1981: 171), although branching points do not denote actual speciation events or real ancestors.

The current distribution of the genus in Africa, Madagascar, India and South East Asia suggests that it arose when the African, Malagasy and Indian land-masses were still closely associated, namely before the end of the Cretaceous (Smith, Hurley & Briden, 1981). Each of these three components carried its own fragmented group of species, and the further dispersal and evolution of the genus would have occurred when India became linked with South East Asia (Late Eocene/Oligocene).

This kind of model seems more useful than postulating the origin of the genus in one of the three main areas of its distribution (Africa, India, South East Asia) with subsequent long-range dispersal to the other two. Several other macronematine genera have similar widespread distributions, such as *Polymorphanisus* Walker, *Aethaloptera* and *Macrostemum* (the latter also occurring in the New World), and their long-range dispersal seems similarly unlikely in view of their relatively limited powers of flight and their restriction to certain freshwater habitats. Some other genera of the subfamily are restricted to one continent; *Protomacronema*, which may be the sister-group of *Amphipsyche* is found only in Africa, and future studies on these genera should indicate whether or not this model is satisfactory.

The *meridiana*-group of *Amphipsyche* has representatives in Africa, Madagascar, India and South East Asia, but it is important to note that not all the African species form a monophyletic group. *A. senegalensis* was apparently an early coloniser of Africa, where it is now the most widespread species (Fig. 119), but all the other African species (including *pellucida* from Madagascar) form a monophyletic group with allopatric distributions. Each member of this sub-group is individually sympatric with *senegalensis*, which tends to confirm their more distant relationship with that species (Nelson & Platnick, 1981: 384). The *apicalis*- and *proluta*-groups

have no African representatives but both occur in India and South East Asia. It thus seems likely that both arose from a common Indian ancestral species, and that each group later dispersed and speciated throughout South East Asia, along with some members of the *meridiana*-group.

Check-list of *Amphipsyche* species

Although most of the species in this list are arranged according to the relationships suggested by the cladistic analysis (Fig. 11), they are not phyletically sequenced (Wiley, 1981: 211). This is partly because three species, *bengalensis*, *delicata* and *extrema*, were omitted from the cladogram owing to lack of suitable material; these species would be *sedis mutabilis* sensu Wiley. Moreover, the cladogram is not of the simple asymmetrical 'pectinate' type which lends itself to this sequencing convention without the proliferation of formal subgroup names.

AMPHIPSYCHE McLachlan

- Phanostoma* Brauer
- Amphipsychella* Martynov **syn. n.**
- proluta*-group
- proluta* McLachlan
- paraprolyta* Hwang **syn. n.**
- bifasciata* Navás
- distincta* Martynov
- delicata* Banks
- apicalis*-group
- apicalis* Banks
- exsiliens* **sp. n.**
- gratiosa* Navás
- petiolata* Ulmer
- minima* Banks **syn. n.**
- pubescens* Kimmins **syn. n.**
- meridiana*-group
- senegalensis* (Brauer)
- curvinerve* (Navás) **syn. n.**
- magna* Banks

parva Banks

- meridiana* Ulmer
- nirvana* Banks **syn. n.**
- vedana* Banks **syn. n.**
- propinqua* Ulmer **syn. n.**
- indica* Martynov **syn. n.**
- tricalcarata* Martynov
- sigmosa* Navás **syn. n.**
- sinhala* **sp. n.**
- bengalensis* Martynov
- extrema* (Martynov) **comb. n.**
- pellucida* (Navás) **comb. n.**
- instabilis* Kimmins
- plicata* (Jacquemart) **syn. n.**
- ulmeri* Kimmins
- scottae* Kimmins
- fuscata* Kimmins
- corbeti* Kimmins
- berneri* Kimmins

Key to species of *Amphipsyche*

Of necessity this key is based largely on features of the male genitalia, which are often the only reliable way of distinguishing species in this genus; moreover, the females of nine of the species are unknown. However, geographical distribution and external characters such as wing venation and spur formulae are used where feasible, so that isolated female specimens can be identified as far as possible.

1	Spur on fore tibia absent	2
-	Spur on fore tibia present	16
2	(1) Four spurs on hind tibia; ♀; R_1 in fore wing ends on Sc (Fig. 39) (♂ unknown) <i>delicata</i> (p. 93)	
-	Two or three spurs on hind tibia; R_1 in fore wing ends on wing margin	3
3	(2) ♂: phallosome with three pairs of endothecal spines (Fig. 82)	4
-	♂: phallosome with only two pairs of endothecal spines or less	5
4	(3) Very large species, fore wing 15–20 mm; pair of round markings on mesoscutellum (Fig. 87) (Philippines)	<i>magna</i> (p. 102)
-	Small species, fore wing 8 mm; no markings on mesoscutellum (♀ unknown) (Borneo)	<i>parva</i> (p. 105)
5	(3) Indian or Sri Lankan species	6
-	African or Malagasy species	9
6	(5) ♀: maxillary palps very short (Fig. 116); only one or two spurs on mid tibia (♂ unknown)	<i>extrema</i> (p. 112)
-	Maxillary palps unmodified; four spurs on mid tibia	7
7	(6) Spurs 0.4.2	8
-	Spurs 0.4.3 or 0.4.4	<i>meridiana</i> (p. 106)

- 8 (7) ♂: endothecal spines rod-like, longer than breadth of phallosome stem (Fig. 117) (♀ unknown) (India) *bengalensis* (p. 111)
 - ♂: endothecal spines much shorter than breadth of phallosome stem (Fig. 98) (Sri Lanka) *sinhala* (p. 105)
- 9 (5) Hind tibia with three spurs; ♂: base of phallosome extended into two pointed lobes (Fig. 134) (Malagasy species) *pellucida* (p. 115)
 - Hind tibia with two spurs; ♂: phallosome of other shape (Afrotropical species) 10
- 10 (9) ♂: endothecal spines absent (Fig. 124) *senegalensis* (p. 112)
 - ♂: at least one endothecal spine present 11
- 11 (10) Cross-vein present between M_{3+4} and Cu_{1a} in hind wing (Figs 140, 147); ♂: mid endothecal spines fused into single structure (Fig. 145) *instabilis* (p. 117)
 - No such cross-vein in hind wing; ♂: mid endothecal spines paired 12
- 12 (11) ♂: fifth segment of maxillary palp fused with fourth (line of fusion visible in *fusca*, Fig. 167); apex of phallosome rounded (Fig. 175) 13
 - ♂: fifth segment of maxillary palp distinct (sometimes reduced in length); apex of phallosome pointed (Fig. 159) 15
- 13 (12) ♂: diagonal fuscous marking on fore wing (Fig. 165); base of phallosome narrow (Fig. 169) (♀ unknown) *fusca* (p. 123)
 - ♂: no diagonal wing marking; base of phallosome broadly triangular (Fig. 175) 14
- 14 (13) ♂: lobes of tenth segment broad and divergent in dorso-ventral view (Fig. 180) (♀ unknown) (Ghana) *berneri* (p. 127)
 - ♂: lobes of tenth segment narrow, subparallel in dorso-ventral view (Fig. 176) (♀ unknown) (Uganda) *corbeti* (p. 125)
- 15 (12) ♂: mid endothecal spines gently curved dorsally (Fig. 159) (South Africa) .. *scottae* (p. 121)
 - ♂: mid endothecal spines turned abruptly dorsally (Fig. 154) (♀ unknown) (Sudan) *ulmeri* (p. 120)
- 16 (1) Genae flat with silverish pubescence; fork II stalked in fore wing (Fig. 54) 17
 - Genae rounded with no pubescence; fork II sessile in fore wing (Fig. 12) 20
- 17 (16) 'False' discoidal cell in fore wing (enclosing corneous spot) (Fig. 43) (India) ... *apicalis* (p. 94)
 - No 'false' discoidal cell 18
- 18 (17) ♂: phallosome with eversible endotheca (Figs 59, 60) (♀ unknown) (Burma) *exsiliens* (p. 96)
 - ♂: phallosome without eversible endotheca 19
- 19 (18) Fore wing with striking pattern of five dark brown spots with other paler brown markings (Fig. 61); ♂: phallosome with large dorsal leaf-like lobes (Fig. 65) (♀ unknown) *gratiosa* (p. 98)
 - Fore wing with only one dark brown spot in fork I (Fig. 68); ♂: phallosome with no dorsal lobes (Fig. 72) *petiolata* (p. 99)
- 20 (16) Cross-vein present between M_{3+4} and Cu_{1a} in hind wing (Fig. 12) *proluta* (p. 86)
 - No such cross-vein in hind wing 21
- 21 (20) Vertex of head, antennal scape and pedicel with dark brown markings (Fig. 30) *distincta* (p. 89)
 - No markings on head (♀ unknown) *bifasciata* (p. 89)

The *proluta*-group

Genae rounded, with no pubescence. Fork II sessile in fore wing. Spurs usually 1.4.4 but subject to reduction. Fifth segment of maxillary palp long and secondarily annulated. ♂ interior appendages with basal segment broad, at least distally; phallosome pocket present; pre-anal appendages present though small (absent in *distincta*). Phallosome lacking endothecal spines. Ninth segment with two rows of setae (dorsal and lateral) in lateral view.

India, China and U.S.S.R. (Amur region).

Amphipsyche proluta McLachlan

(Figs 12–21)

Amphipsyche proluta McLachlan, 1872: 70. Lectotype ♂, U.S.S.R. (BMNH), designated by Kimmins, 1957b: 105 [examined].

Amphipsyche paraprolyta Hwang, 1957: 387. Holotype ♂, CHINA: Jiangsu Prov., Nanjing, 15.viii.1956 (*Hwang*) (NAC) [not examined]. **Syn. n.**

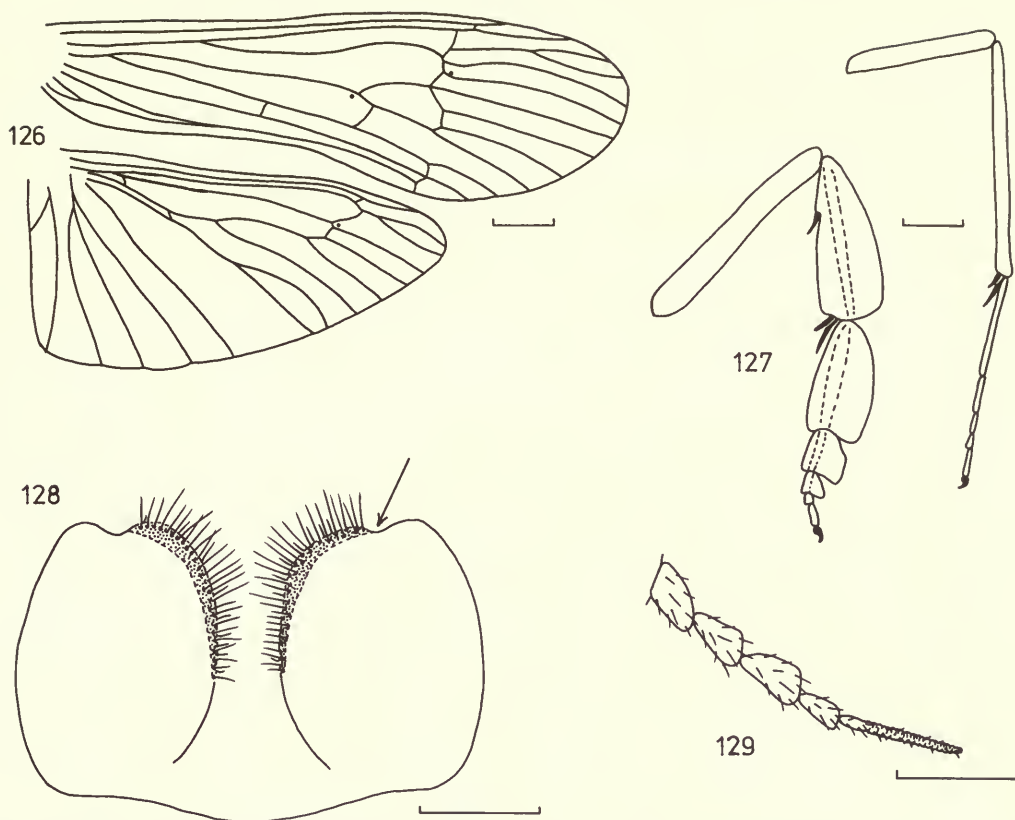

Figs 126–129 *Amphipsyche senegalensis* ♀. 126, wing venation; 127, mid and hind legs; 128, eighth sternites; 129, maxillary palp.

and Ulmer (1963) (as *curvinerve*); the pupa was described by Gibbs (1973) and Marlier (1978).

In addition to the distribution records below, Navás (1923) also recorded this species from Madagascar, but this is unconfirmed.

MATERIAL EXAMINED

Lectotype ♂ of *senegalensis*, Senegal: 1869 (*Steindachner*) (NM). Lectotype ♀ of *curvinerve*, Egypt: Cairo, 20.vii.1916 (*Alfieri*) (USNM).

79 ♂, 194 ♀, 3 larvae, 3 pupae, Chad, Sudan, Ethiopia, Ghana, Nigeria, Cameroun, Zaire, Uganda, Tanzania, Zambia, Malawi, Zimbabwe, South Africa (Transvaal) (BMNH, IRSNB, MRAC, RSM, USNM, ZI).

Amphipsyche pellucida (Navás) comb. n.

(Figs 130–139; distribution, Fig. 119)

Protomacronema pellucidum Navás, 1923: 26. Holotype ♀, MADAGASCAR (MNHN) [examined].

♂. Antenna 45 mm, with c. 80 segments. Fore wing 15–16 mm. Body yellowish brown; basal antennal segments annulated with dark brown, apical segments fuscous. Fore wing very pale yellow, with faint darker stripe from R_1 to M in line with $M-Cu_1$ cross-vein. Venation as in Fig. 130. Spurs 0.4.3 (Fig. 131). Maxillary palp 5-segmented, 5th segment not secondarily annulated, shorter than segments 1–3 combined (Fig. 132).

♀. Antenna 15 mm, with c. 60 segments. Fore wing 11–13 mm. Coloration as in ♂. Fore wing with no markings, venation as in Fig. 136. Spurs 0.4.3 (Fig. 137). Maxillary palp similar to that of ♂ (Fig. 139).

GENITALIA ♂ (Figs 133–135). Ninth segment broadly rounded laterally. Base of phallosome narrow, with

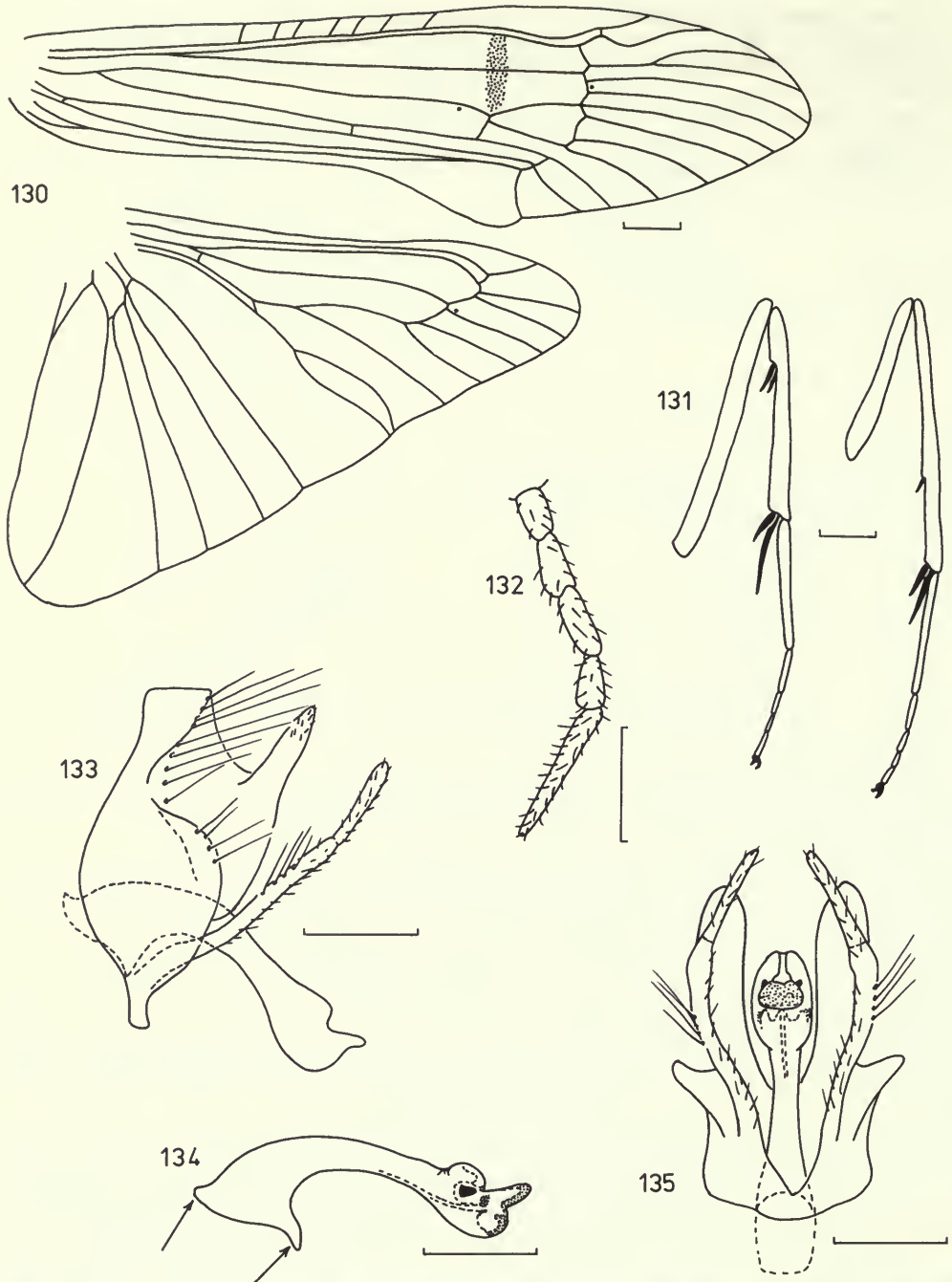

Figs 130–135 *Amphipsyche pellucida* ♂. 130, wing venation; 131, mid and hind legs; 132, maxillary palp; 133, genitalia, lateral view; 134, phallosome, lateral view; 135, genitalia, ventral view.

basal corners produced into pointed lobes. Stem of phallosome narrow, apex produced into an elongate lobe. Only mid endothelial spines present, very short and blunt. Inferior appendage slender and sinuous, terminal segment clearly differentiated.

GENITALIA ♀ (Fig. 138). Eighth sternites oval, each sclerite almost symmetrical, with all corners rounded.

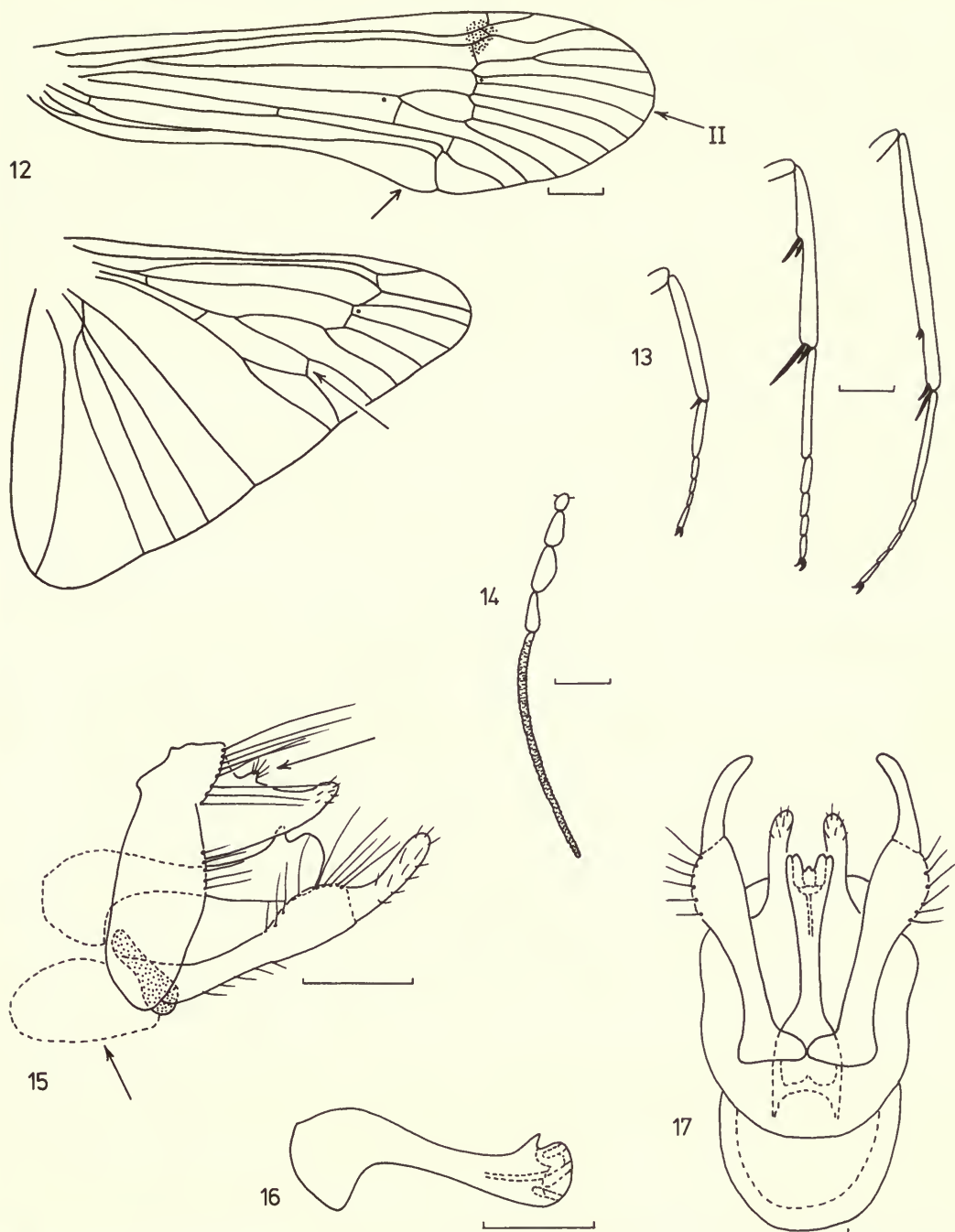

Figs 12–17 *Amphipsyche proluta* ♂. 12, wing venation; 13, legs; 14, maxillary palp; 15, genitalia, lateral view; 16, phallosome, lateral view; 17, genitalia, ventral view.

♂. Antenna c. 30 mm, with c. 80 segments. Fore wing 11–14 mm. Body pale yellowish brown, antenna pale yellow, narrowly annulated with brown, becoming more fuscous towards antennal apex. Fore wing very pale yellow, with slightly darker marking around $Sc-R_1$ cross-vein, sometimes extending further onto anastomosis. Venation as in Fig. 12; cross-vein present between M_{3+4} and Cu_{1a} in hind wing. Spurs 1.4.4;

pre-apical spurs on hind tibia very short (Fig. 13). Maxillary palp 5-segmented, 5th segment secondarily annulated, over 1.5 times length of segments 1-4 combined (Fig. 14).

♀. Antenna c. 12 mm, with c. 50 segments. Fore wing 8-10 mm. General coloration as in ♂, fore wing with no dark markings. Venation as in Fig. 18; $M_{3+4}-Cu_{1a}$ cross-vein in hind wing, as in ♂. Spurs 1.4.4 (Fig. 19). Maxillary palp similar to that of ♂, but 5th segment approximately same length as segments 1-4 combined (Fig. 21).

GENITALIA ♂ (Figs 15-17). Ninth segment narrow laterally, pre-anal appendages present as small setigerous projections on tenth segment (Fig. 15). Phallocrypt pocket relatively broad and rounded (Fig. 15). Basal segment of inferior appendage broad apically only, terminal segment partly differentiated. Phallosome slender with narrow base; apex truncate, with slightly pointed lobe dorsally.

GENITALIA ♀ (Fig. 20). Eighth sternites broad, squarish; thickened inner margins wide, extending far down inner edges.

REMARKS. Although easily identified by the male genitalia, both sexes of this species can be distinguished from the rest of the *proluta*-group by the $M_{3+4}-Cu_{1a}$ cross-vein in the hind wing. The only other species to show this character is *instabilis*, in the *meridiana*-group.

Hwang (1957) described *paraprolyta* as differing from *prolyta* in the male genitalia. However, it seems that he had only McLachlan's original description on which to base his comparison, and both McLachlan's description and figure of *prolyta* are very poor. McLachlan saw only dried material, and the pointed valves, which he thought were the intermediate appendages, are apparently the tenth segment. McLachlan's (1878: 352) redescription of the species was rather better, with a clearer figure; here he noted the setigerous pre-anal appendage as 'a distinct tooth'. McLachlan's type-series of three males and two females is extant in the BMNH, although Kimmins (1957b) did not mention this in his lectotype designation.

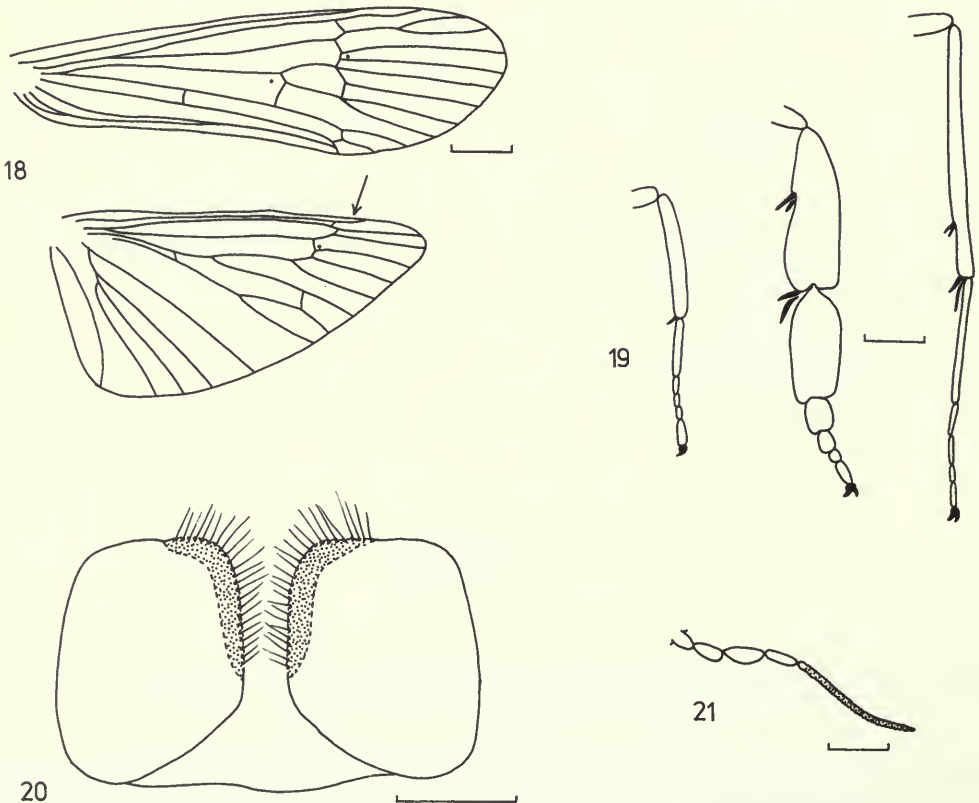

Figs 18-21 *Amphipsyche proluta* ♀. 18, wing venation; 19, legs; 20, eighth sternites; 21, maxillary palp.

Although Hwang's (1957) description was apparently based on one male holotype, I was lent a male specimen from NAC labelled as paratype, which had identical data to the type. Whether or not this specimen has any type-status, it is an important 'topotypic' specimen, and examination of it confirmed the synonymy of *paraproluta* with *proluta*.

Three specimens examined (MNHN, MCZ) are labelled 'Hanléon', apparently from China, according to Navás (1914). However, this is an impossible combination of letters for a Chinese place-name, and the label data must have been mis-copied from another, presumably handwritten, source. I tentatively suggest that the 'ls' is a misreading of the single (handwritten) letter 'k', and the final 'n' a misreading of 'u'. This would give the more plausible transliteration of 'Hankéou', the French spelling of Han-kow, for material collected by the Frenchman, de Guerne.

The larva of *proluta* was described by Lepneva (1947; 1970).

MATERIAL EXAMINED

Lectotype ♂ of *proluta*, U.S.S.R.: 'Amur Land' (*Maack*) (BMNH).

19 ♂, 8 ♀, U.S.S.R.: Amurskaya (2 ♂, 2 ♀ paralectotypes of *proluta*), China (1 ♂ 'paratype' of *paraproluta*) (BMNH, MCZ, MNHN, NAC).

Amphipsyche bifasciata Navás

(Figs 22–27)

Amphipsyche bifasciata Navás, 1931a: 7. Holotype ♂, CHINA: 'méridionale' (*Bris*) (lost).

[*Amphipsyche proluta* McLachlan; Banks, 1940: 207; Mosely, 1942: 361. Misidentifications.]

♂. Antennal length unknown (both specimens damaged). Fore wing 10–15 mm. Antennal segments pale yellow, with golden brown annulations. Head, thorax and abdomen yellowish brown. Fore wing pale yellow, shaded pale brown at apex and with darker brown stripe across anastomosis. Venation as in Fig. 22; fork I in fore wing approximately equal in length to its stalk. Spurs 1.4.4 (Fig. 24). Maxillary palp 5-segmented, 5th segment secondarily annulated, longer than segments 1–4 combined (Fig. 23).

♀. Unknown.

GENITALIA ♂ (Figs 25–27). Ninth segment relatively narrow laterally; pre-anal appendages present as small setigerous projections on tenth segment. Phallocrypt pocket elongate and sac-like in lateral view, shield-shaped in ventral view (Fig. 27). Basal segment of inferior appendage very broad, viewed laterally and ventrally; terminal segment clearly differentiated. Phallosome slender, apex truncate, with pair of pointed unsclerotized lobes (superficially resembling endothelial spines); dorsally a single pointed lobe.

REMARKS. Well-marked examples of this species are easily recognized by the wing markings, but the single male examined from Szechwan has lost virtually all these markings, and is easily confused with *proluta*, hence Banks's (1940) misidentification.

According to the original description the holotype of *bifasciata* should be in Navás's collection, now in Barcelona, but when this was examined in 1979 the type was apparently missing (T. R. New, pers. comm.). However, Navás's illustration of the wing is sufficient to identify the species; it is obvious from his figure that the type is a male, although Navás does not mention this.

MATERIAL EXAMINED

2 ♂, China (BMNH, USNM).

Amphipsyche distincta Martynov

(Figs 28–38)

Amphipsyche distincta Martynov, 1935: 196. 6 ♂ syntypes, INDIA: Madhya Pradesh, river at Mandla, Nerbudda Survey (*Pruthi*) (lost from ZSI).

♂. Antenna up to 25mm, with c. 80 segments. Fore wing 8–10 mm. Body pale yellowish brown; setigerous warts on vertex of head dark greyish brown; antennal scape and pedicel with dark brown longitudinal stripe on dorsal surface (Fig. 30); front femur dark brown. Fore wing pale yellow, no dark markings. Venation as in Fig. 28; in fore wing fork IV with short stalk; in hind wing 5c not reaching wing

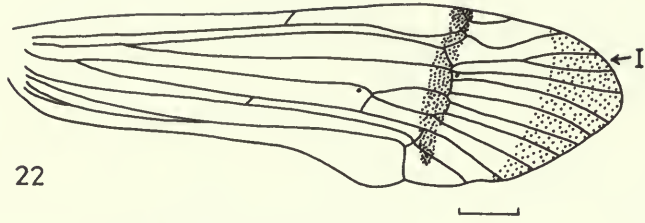

22

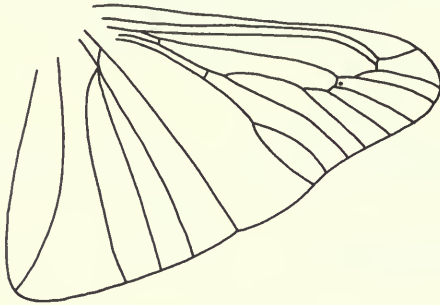

23

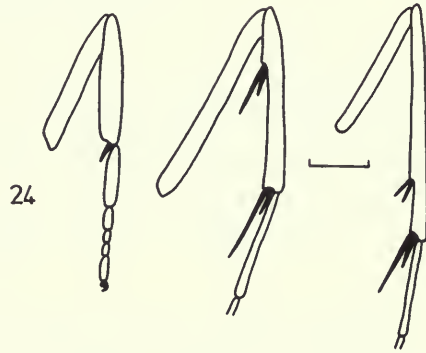

24

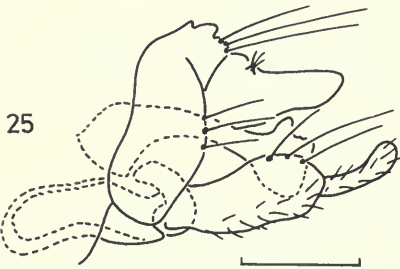

25



26

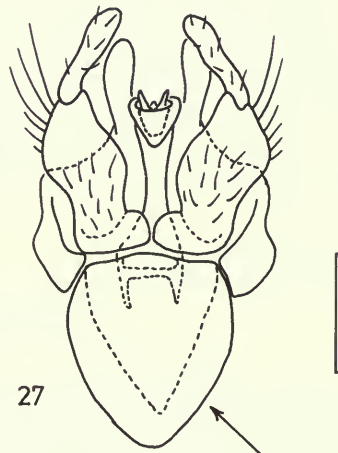

27

Figs 22–27 *Amphipsyche bifasciata* ♂. 22, wing venation; 23, maxillary palp; 24, legs; 25, genitalia, lateral view; 26, phallosome, lateral view; 27, genitalia, ventral view.

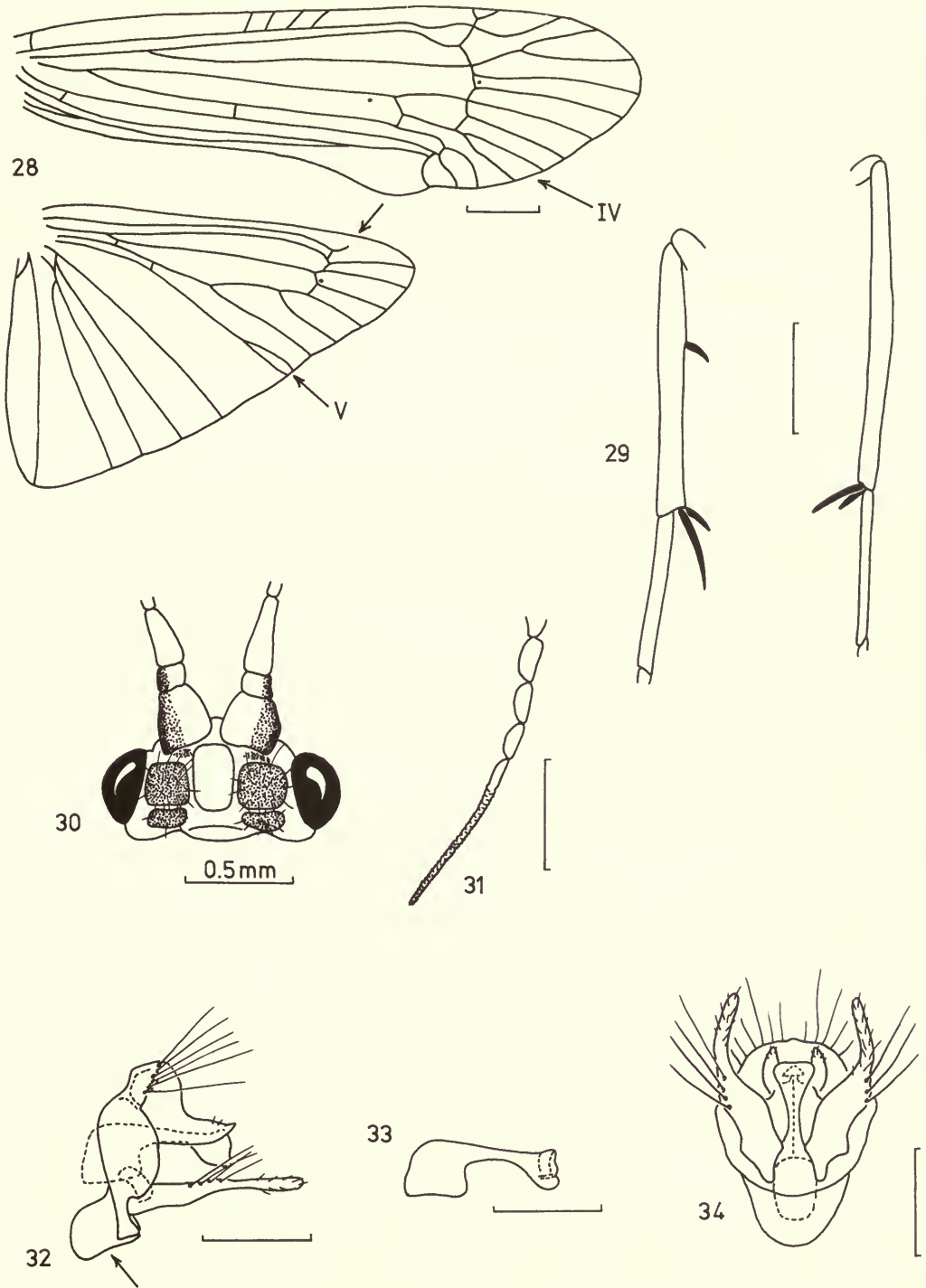

Figs 28–34 *Amphipsyche distincta* ♂. 28, wing venation; 29, mid and hind tibiae; 30, head, dorsal view; 31, maxillary palp; 32, genitalia, lateral view; 33, phallosome, lateral view; 34, genitalia, ventral view.

margin, fork V very narrow. Spurs 0.3.2 (Fig. 29). Maxillary palp 5-segmented, 5th segment secondarily annulated, longer than segments 1-4 combined (Fig. 31).

♀. Antenna up to 10 mm, with c. 50 segments. Fore wing 6-8 mm. Coloration as in ♂. Venation as in Fig. 35; in fore wing R_1 ends on Sc , fork IV sessile. In hind wing Cu_1 not forked, 2A absent. Spurs (Fig. 36) and maxillary palp (Fig. 37) as in ♂.

GENITALIA ♂ (Figs 32-34). Ninth segment broad laterally, pre-anal appendages absent. Phallocrypt pocket rounded in lateral view (Fig. 32), broadly triangular in ventral view. Inferior appendage broad and sinuous in ventral view, terminal segment not differentiated. Phallosome broad basally, with narrow stem; apex triangular with no obvious appendages or lobes.

GENITALIA ♀ (Fig. 38). Eighth sternites broad, with squarish corners; thickened inner margins extending barely half length of sclerites.

REMARKS. This aptly named species is so distinctive that it is easily recognized; no other species has markings on the head and antennae (the only other species with any body markings is *magna*, with a pair of spots on the mesoscutellum).

Banks (1939) redescribed *distincta*, drawing attention to the dark front femur in both sexes. Martynov had described all the legs as being pale, but since all six syntypes are apparently lost (Ghosh, *in litt.*) this character cannot be checked on Martynov's material. Banks also stated that fresh specimens were 'plainly greenish'.

Martynov listed as the syntypes '4 ♂' followed by '2 ♂' with identical data; one of these may

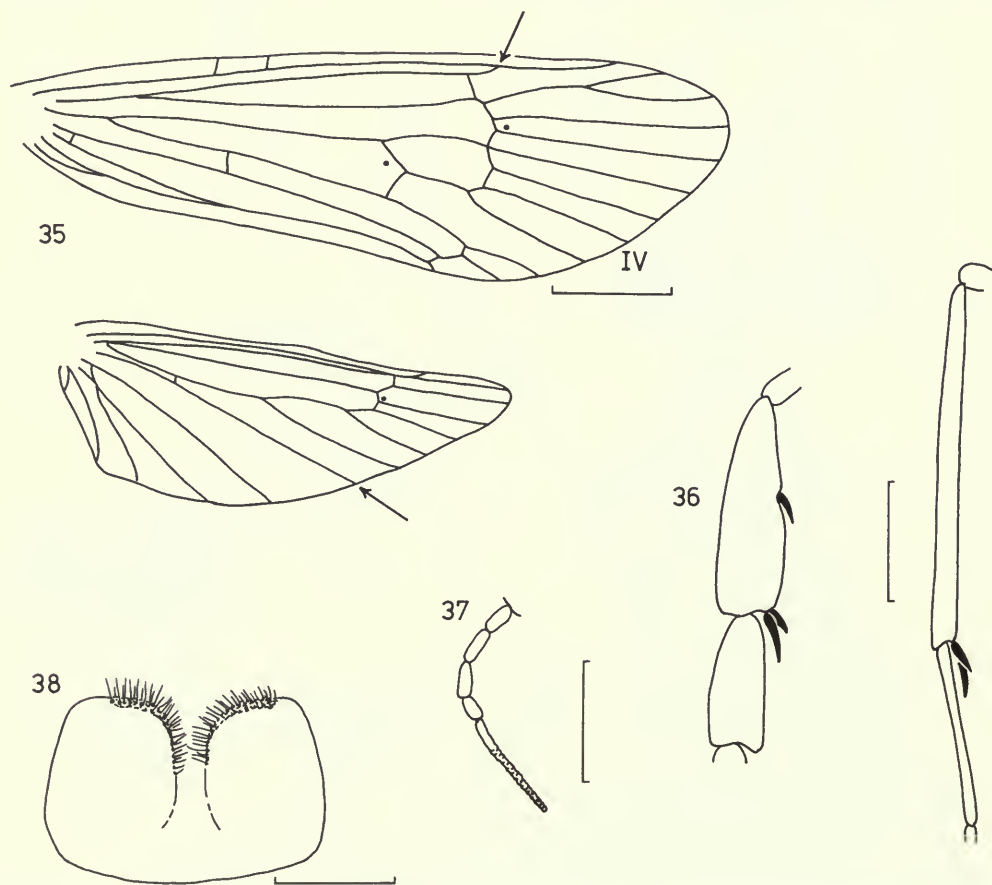

Figs 35-38 *Amphipsyche distincta* ♀. 35, wing venation; 36, mid and hind tibiae; 37, maxillary palp; 38, eighth sternites.

be an error for '♀'. No descriptions of the female are given in his text, but this is also true of his description of *indica* (= *meridiana*), where both males and females make up the type-series.

A neotype designation does not seem necessary for such an easily recognizable species.

MATERIAL EXAMINED

19 ♂, 28 ♀, India (MCZ, USNM).

Amphipsyche delicata Banks

(Figs 39–42)

Amphipsyche delicata Banks, 1939: 58. LECTOTYPE ♀, CHINA (MCZ), here designated [examined].

♂. Unknown.

♀. Antenna over 12 mm, with more than 50 segments (all specimens damaged). Fore wing 6–8 mm. Antennal segments pale yellow, slightly annulated with brown. Head, thorax and abdomen yellowish brown. Fore wing very pale yellow with no markings, venation as in Fig. 39. R_1 in fore wing ends on *Sc*. Spurs 0.4–4 (Fig. 40). Maxillary palp 5-segmented, 5th segment secondarily annulated, longer than segments 1–4 combined (Fig. 41).

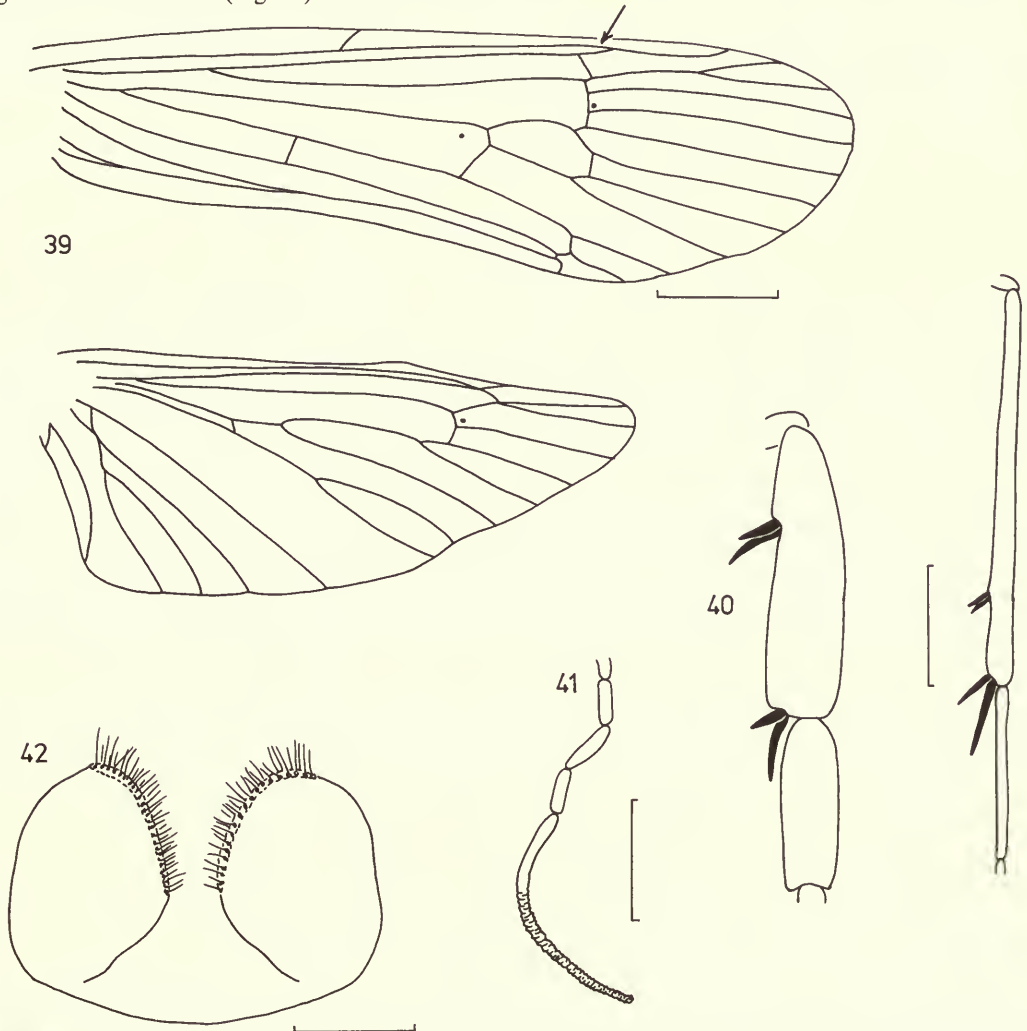

Figs 39–42 *Amphipsyche delicata* ♀. 39, wing venation; 40, mid and hind tibiae; 41, maxillary palp; 42, eighth sternites.

GENITALIA ♀ (Fig. 42). Eighth sternites rounded, bluntly pointed posteriorly; thickened inner edge relatively narrow.

REMARKS. The relationships of this species are in some doubt, mainly because no males have yet been discovered. Banks (1939) compared it with *minima* (= *petiolata*), from which it differs in venation, and with *distincta*, which he distinguished by the dark fore femora. It seems to be most closely related to *distincta*, with which it shares the venational feature of R_1 ending on Sc in the fore wing; this may be a synapomorphy for this pair of species. However, the placing of this species in the *proluta*-group is complicated by its unique spur formula of 0.4.4. It cannot belong in the *apicalis*-group because of the sessile fork II in the fore wing, and its Chinese distribution and unmodified maxillary palps make its inclusion in the *meridiana*-group unlikely.

The specimen here designated as lectotype was labelled 'type' by Banks, but not so published.

MATERIAL EXAMINED

Lectotype ♀, China: Hainan Tao I., Chung Kon, 18.vii.1935 (*Gressitt*) (type no. 23470, MCZ).
6 ♀ (paralectotypes), China (MCZ).

The *apicalis*-group

Genae flat, with silverish pubescence. Fore wing with fork II stalked, dark marking in fork I. Spurs always 1.4.4. Fifth segment of maxillary palp long and secondarily annulated (except ♀ *apicalis*). ♂ inferior appendages slender; phallocrypt pocket and pre-anal appendages absent. Phallosome lacking endothelial spines. Ninth segment with two rows of setae as in *proluta*-group.

India, Burma, Thailand, Vietnam, West Malaysia, Sumatra and Borneo (Sarawak).

Amphipsyche apicalis Banks

(Figs 43–53)

Amphipsyche apicalis Banks, 1939: 56. LECTOTYPE ♂, INDIA (MCZ), here designated [examined].

♂. Antenna over 20 mm, with more than 50 segments (broken in both specimens examined). Fore wing 12–13 mm. Antennal segments pale golden brown, becoming more fuscous towards apex, slightly annulated with brown. Head, thorax and abdomen yellowish brown. Fore wing golden yellow, with dark brown spot in fork I, glabrous brown streaks at wing apex proximal to dark spot and across anastomosis (Fig. 43). In fore wing 'false' discoidal cell enclosing corneous spot at base of R_{4+5} , fork I with short stalk. R_{2+3} fused in hind wing. Spurs 1.4.4, pre-apical spurs on hind tibia short (Fig. 44). Maxillary palp 5-segmented, 5th segment secondarily annulated, longer than segments 1–4 combined (Fig. 45).

♀. Antenna over 12 mm, with more than 50 segments (broken in both specimens examined). Fore wing 9–10 mm. Body coloration as in ♂. Fore wing yellowish brown with pale brown spot on wing margin in fork I and another at anterior end of anastomosis (Fig. 50). Fore wing with 'false' discoidal cell as in ♂, but not so clearly defined. Spurs 1.4.4, one pre-apical spur on hind tibia very small (Fig. 51). Maxillary palp 5-segmented, 5th segment not annulated, approximately equal in length to segments 1 and 2 combined (Fig. 52).

GENITALIA ♂ (Figs. 46–49). Ninth segment with enlarged rounded side-pieces. Phallosome with slender stem, enlarged apically to form two ventrally directed subtriangular processes; apical process with fine teeth at ventral apex, and hingeing dorsally to form a simple eversible endotheca (Figs 48, 49). Inferior appendage with pronounced setigerous projection mid-dorsally; terminal segment not clearly differentiated.

GENITALIA ♀ (Fig. 53). Eighth sternites with sharp indentation in posterior edge.

REMARKS. Superficially this species is very similar to *exsiliens* and *petiolata*, but is easily distinguished by the characteristic shape of the male phallosome (Fig. 48).

Banks (1939) was unsure whether the two females from Coimbatore belonged to this species, but after examination of his material there seems little doubt that they are correctly placed here. Banks apparently overlooked the 'false' discoidal cell in the females (which is admittedly less obvious than in the males), and he also did not notice the very small pre-apical spur on the hind tibia. The faint wing markings in the female are a reduced form of the pronounced male pattern;

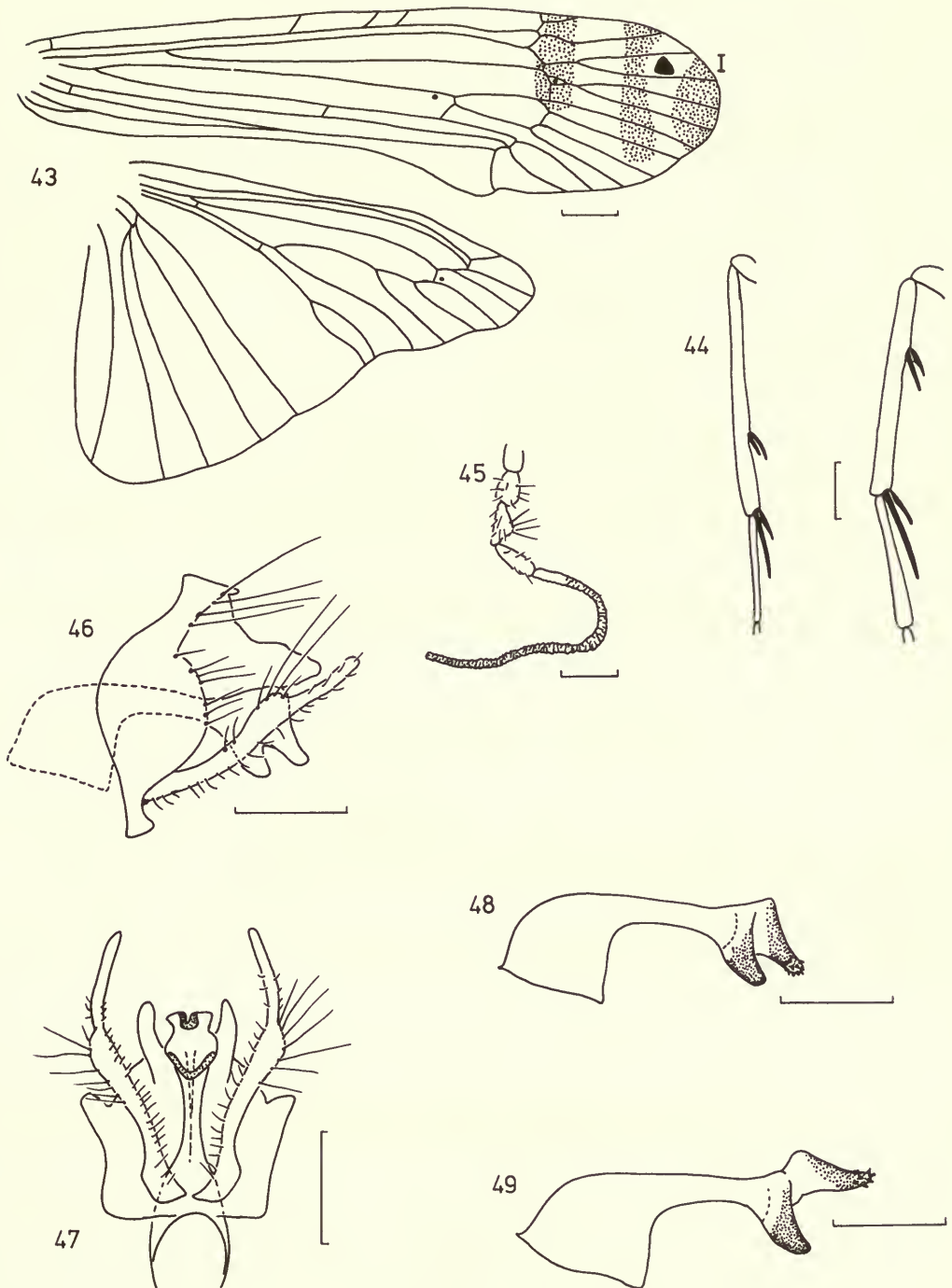

Figs 43–49 *Amphipsyche apicalis* ♂. 43, wing venation; 44, mid and hind tibiae; 45, maxillary palp; 46, genitalia, lateral view; 47, genitalia, ventral view; 48, phallosome, lateral view; 49, phallosome with endothena everted.

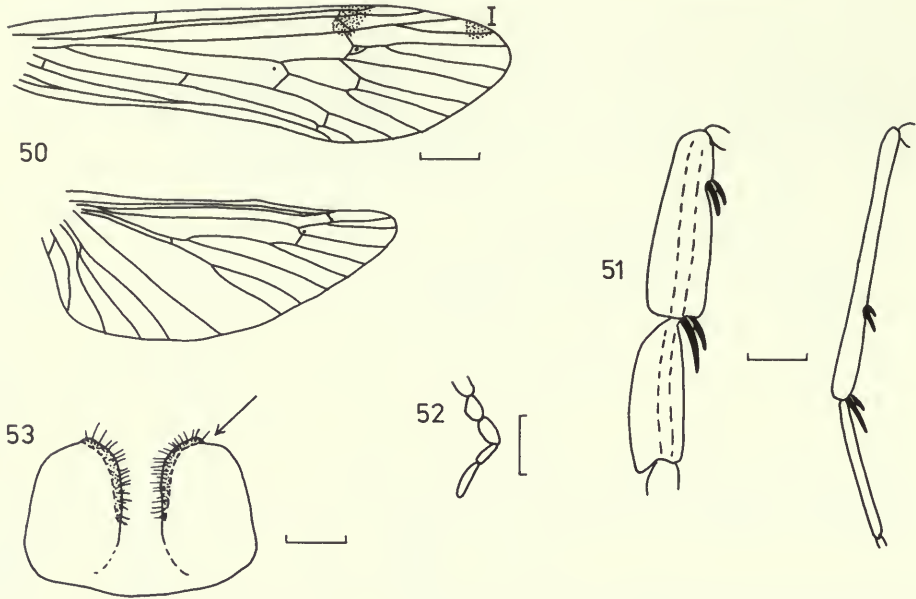

Figs 50–53 *Amphipsyche apicalis* ♀. 50, wing venation; 51, mid and hind tibiae; 52, maxillary palp; 53, eighth sternites.

this is also seen in *petiolata*, and probably also in the closely related *gratiosa* and *exsiliens*, but the females of the last two species have yet to be discovered.

The specimen designated as lectotype was labelled 'type' by Banks, but not so published.

MATERIAL EXAMINED

Lectotype ♂, **India**: Mysore, Shimoga, R. Tunga, 1865' [560 m], at light, 10.vi. [not iv as stated by Banks] [year unknown] (*Nathan*) (type no. 22677, MCZ).

1 ♂ (paralectotype), 2 ♀, **India** (MCZ).

Amphipsyche exsiliens sp. n.

(Figs 54–60)

♂. Antennal length unknown (broken in all specimens). Fore wing 12–14 mm. Body yellowish brown, back of head and dorsal surface of thorax brown; antennal segments pale yellow, narrowly annulated with brown. Fore wing pale yellow with brown spot in fork I and another centred on *Sc-R*₁ cross-vein; pale brown stripe across anastomosis and very pale shading at wing apex. Venation as in Fig. 54. Spurs 1.4.4 (Fig. 55). Maxillary palp 5-segmented, 5th segment secondarily annulated, longer than segments 1–4 combined (Fig. 56).

♀. Unknown.

GENITALIA ♂ (Figs 57–60). Ninth segment broad laterally. Base of phallosome broadly triangular, stem slender with triangular apex. Eversible sac-like endothesa present, connective membrane bearing many small spines (Fig. 60). Inferior appendage slender, terminal segment scarcely differentiated.

REMARKS. This species is easily distinguished from the other members of the *apicalis*-group by the rounded sac-like endothesa, which is more mobile than that of *apicalis*. In the latter species it hinges through only a few degrees, but in *exsiliens* it can be invaginated almost entirely inside the phallosome apex, or hinged through almost 180° to lie dorsal to the apex (Figs 59, 60).

MATERIAL EXAMINED

Holotype ♂, **Burma**: Tenasserim Valley (*Doherty*) (BMNH).

Paratypes. 2 ♂, data as holotype (BMNH).

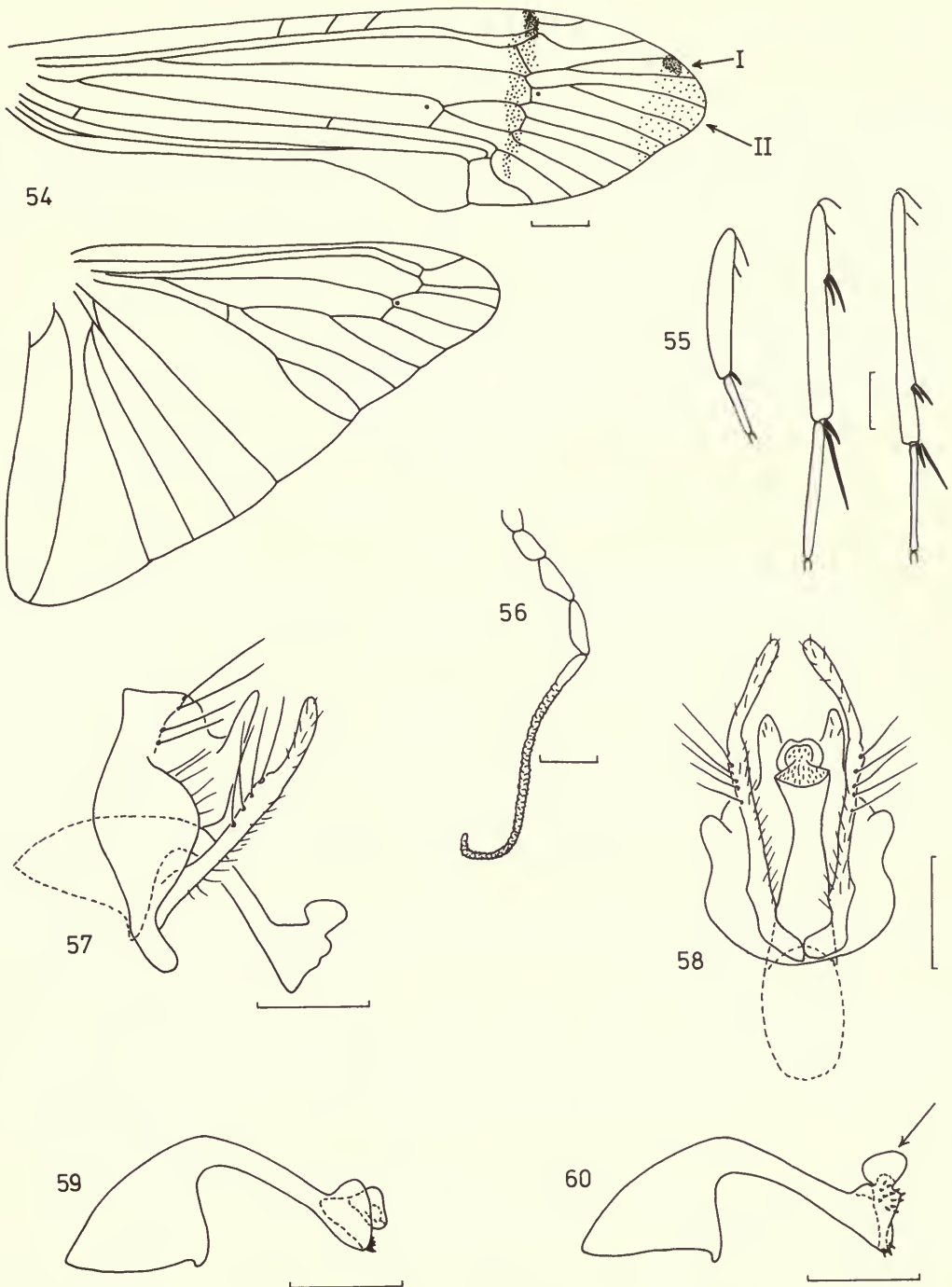

Figs 54–60 *Amphipsyche exsiliens* ♂. 54, wing venation; 55, legs; 56, maxillary palp; 57, genitalia, lateral view; 58, genitalia, ventral view; 59, phallosome, lateral view; 60, phallosome with endotheca everted.

Amphipsyche gratiosa Navás

(Figs 61–67)

Amphipsyche gratiosa Navás, 1922: 62. Holotype ♂, VIETNAM: Tonkin, Hag Song, vii.1918 (lost).

♂. Antenna 25 mm, with c. 85 segments. Fore wing 10–12 mm. Body yellowish brown, antennal segments narrowly annulated with brown. Fore wing pale yellow with striking pattern; pale brown streak across whole width of wing proximal to anastomosis; five dark brown spots in apical area, partially linked to pale brown areas in apical forks; venation as in Fig. 61. Spurs 1.4.4 (Fig. 62). Maxillary palp 5-segmented, 5th segment secondarily annulated, much longer than segments 1–4 combined (Fig. 63).

♀. Unknown.

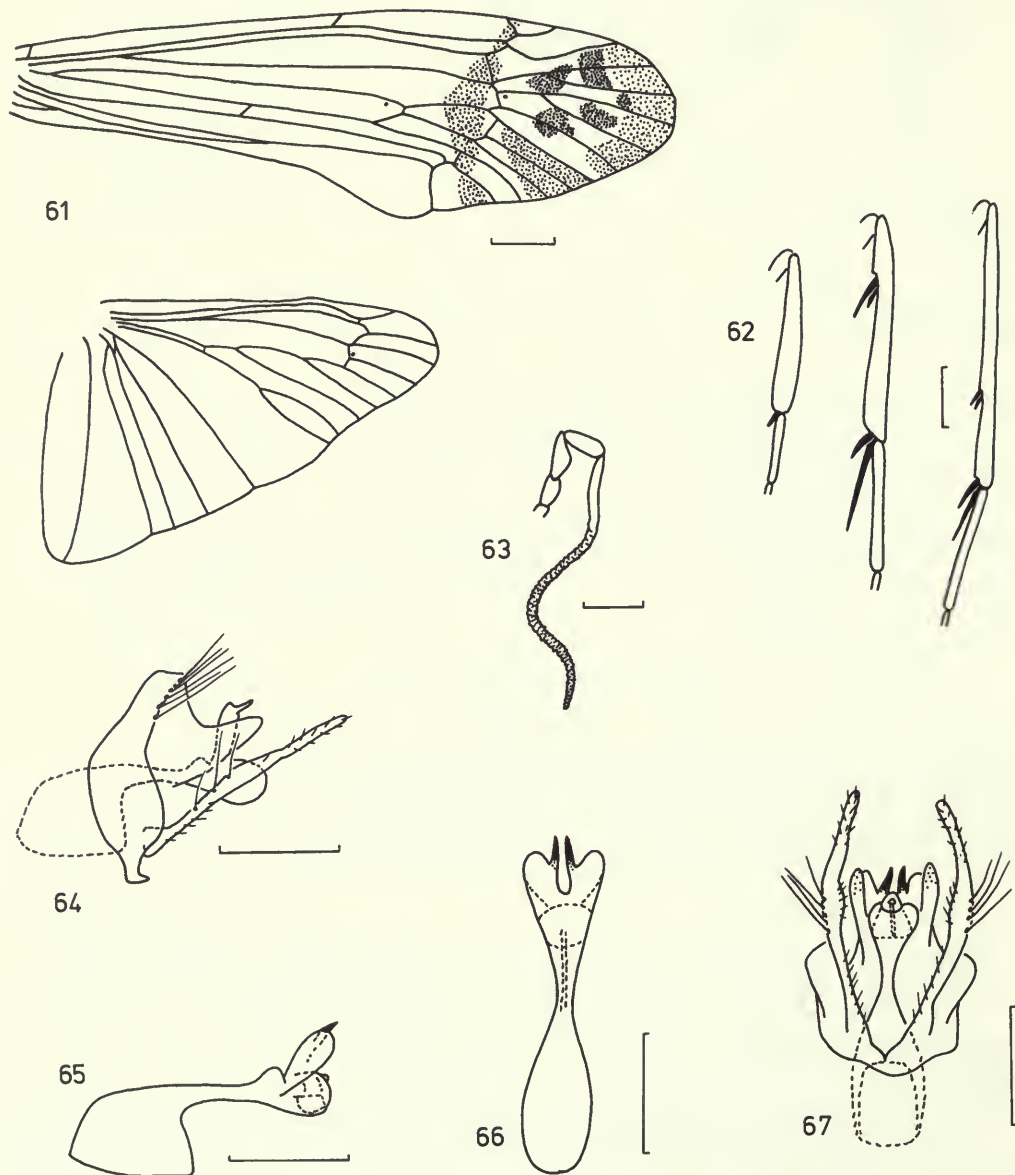

Figs 61–67 *Amphipsyche gratiosa* ♂. 61, wing venation; 62, legs; 63, maxillary palp; 64, genitalia, lateral view; 65, phallosome, lateral view; 66, phallosome, dorsal view; 67, genitalia, ventral view.

GENITALIA ♂ (Figs 64–67). Ninth segment relatively narrow laterally. Base of phallosome elongate, flattened; stem narrow; apex with pair of leaf-like lobes, each bearing single spine on inner surface; pointed dorsal lobe proximal to these apical lobes. Inferior appendage slender; setigerous projection midway on inner surface in ventral view; terminal segment not differentiated.

REMARKS. This species is easily recognized by its prominent wing pattern. The unusual genitalia are also diagnostic, and suggest no close affinities with the other species in the *apicalis*-group. I have assumed that the dorsal lobes are not modified endothelial spines, despite their superficial similarity to those structures, because no other species in the genus has spines with lobate bases. There is certainly a close superficial similarity between the phallosome of this species and that of *meridiana* for example, although all other critical characters of this species definitely place it in the *apicalis*-group. One male examined has a 'false' discoidal cell in the left fore wing only, a character otherwise seen only in *apicalis*.

The type of this species should be in the Navás collection (now in Barcelona) but is apparently missing (T. R. New, pers. comm.); however the species is easily recognizable from Navás's figure. In addition to the distribution records below, the type was collected in Vietnam.

MATERIAL EXAMINED

4 ♂, **Burma, Thailand** (BMNH).

Amphipsyche petiolata Ulmer

(Figs 68–77)

[*Amphipsyche proluta* McLachlan; Ulmer, 1910: 55; 1913: 79. Misidentifications.]

Amphipsyche petiolata Ulmer, 1930: 434. Lectotype ♀ [listed as 'holotype' by Weidner, 1964: 67], JAVA (ZM), designated by Ulmer, 1951: 197 [examined].

Amphipsyche minima Banks, 1931: 395. LECTOTYPE ♀, WEST MALAYSIA (BMNH), here designated [examined]. **Syn. n.**

Amphipsyche pubescens Kimmins, 1955: 387. Holotype ♂, BORNEO (BMNH) [examined]. **Syn. n.**

♂. Antenna c. 35 mm, with c. 80 segments. Fore wing 9–11 mm. Body yellowish brown; posterior part of vertex and dorsal surface of mesothorax brown. Antenna pale yellow, annulated with brown, segments becoming more fuscous towards apex. Fore wing pale golden yellow, with pale brown apex, brownish stripe across anastomosis and dark brown spot in fork I; venation as in Fig. 68. Spurs 1.4.4 (Fig. 69). Maxillary palp 5-segmented, 5th segment secondarily annulated, about three times length of segments 1–4 combined (Fig. 70).

♀. Antenna 10 mm, with c. 45 segments. Fore wing 7–8 mm. General coloration as in ♂. Fore wing very pale yellow, pale brown stripe across anastomosis, sometimes slight brown marking in fork I; venation as in Fig. 74. Spurs 1.4.4 (Fig. 75). Maxillary palp 5-segmented, 5th segment secondarily annulated, about twice length of segments 1–4 combined (Fig. 77).

GENITALIA ♂ (Figs 71–73). Ninth segment broadly rounded laterally. Base of phallosome narrow, rectangular, narrow stem abruptly right-angled. Tip of phallosome globose with bifurcate membranous process arising from apical depression, abruptly up-turned at apex (Fig. 72). Inferior appendage narrow with setigerous median projection on inner surface, terminal segment not differentiated.

GENITALIA ♀ (Fig. 76). Eighth sternites narrow, inner thickened edges slightly incurved; posterior margin produced as rounded point.

REMARKS. The male of this species can be distinguished from others in the *apicalis*-group by the form of the phallosome. The apical rod-like process superficially resembles an endothelial spine but it is a membranous median structure. Within this species-group the only other known female is that of *apicalis*, which has differently shaped eighth sternites and a short apical segment of the maxillary palp.

I have taken Ulmer's subsequent (1951) listing of the Javan syntype as 'type' as a lectotype designation. Weidner (1964) listed this specimen as the holotype, but this is incorrect as Ulmer's original description was based on three syntypes.

It is not clear from Banks's (1931) description of *minima* how many specimens constituted the type-series. Of the two extant syntypes (with identical data, and both labelled 'type' by Banks)

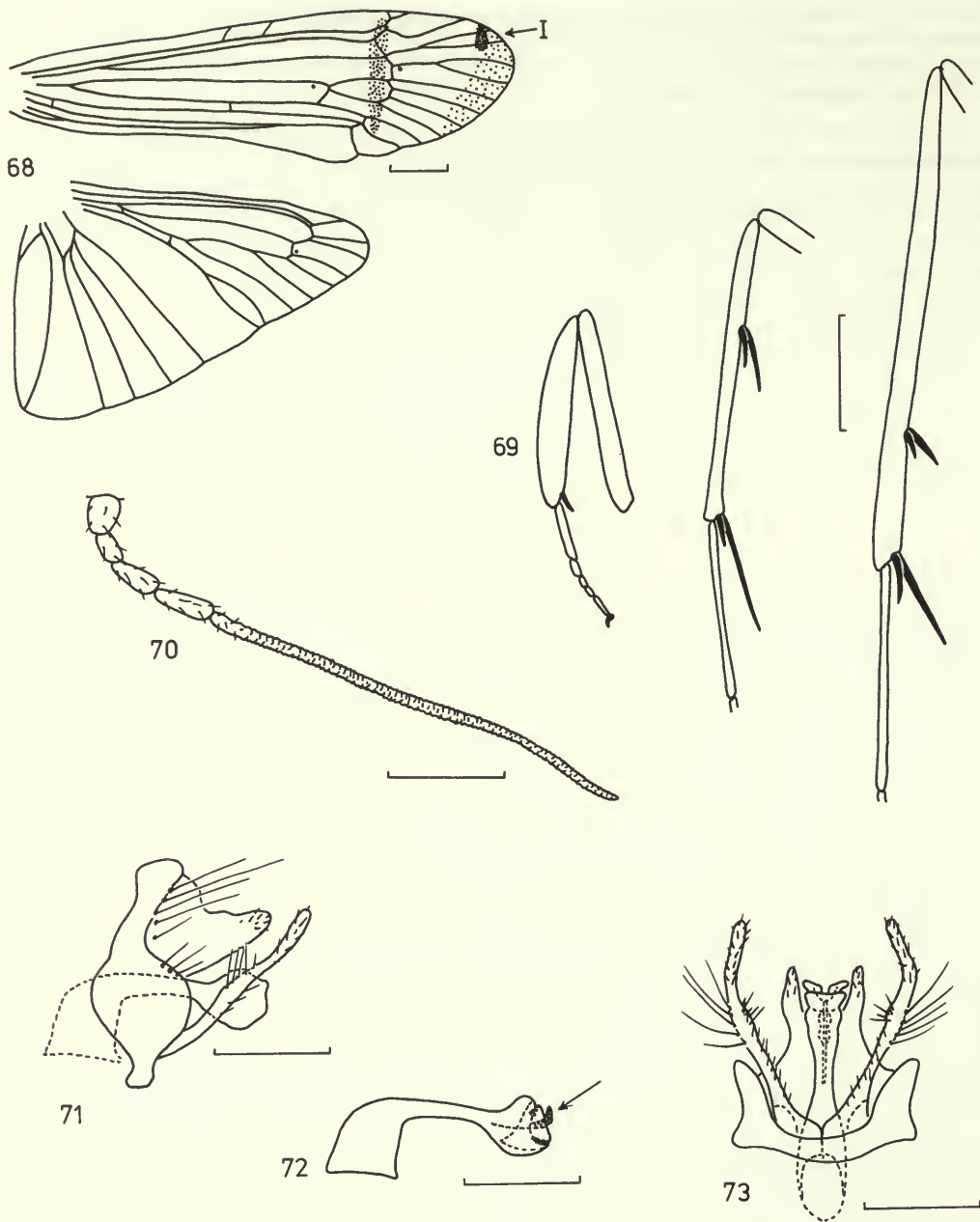

Figs 68–73 *Amphipsyche petiolata* ♂. 68, wing venation; 69, legs; 70, maxillary palp; 71, genitalia, lateral view; 72, phallosome, lateral view; 73, genitalia, ventral view.

the MCZ specimen was labelled 'paratype' by H. H. Ross in 1965. I have therefore designated the BMNH syntype as lectotype. Ulmer (1951) remarked on the similarity of *minima* to *petiolata*.

Mosely identified the type-material of *pubescens* as *petiolata*, but Kimmins decided that it represented a distinct species on the grounds that Ulmer had not mentioned an apical wing spot

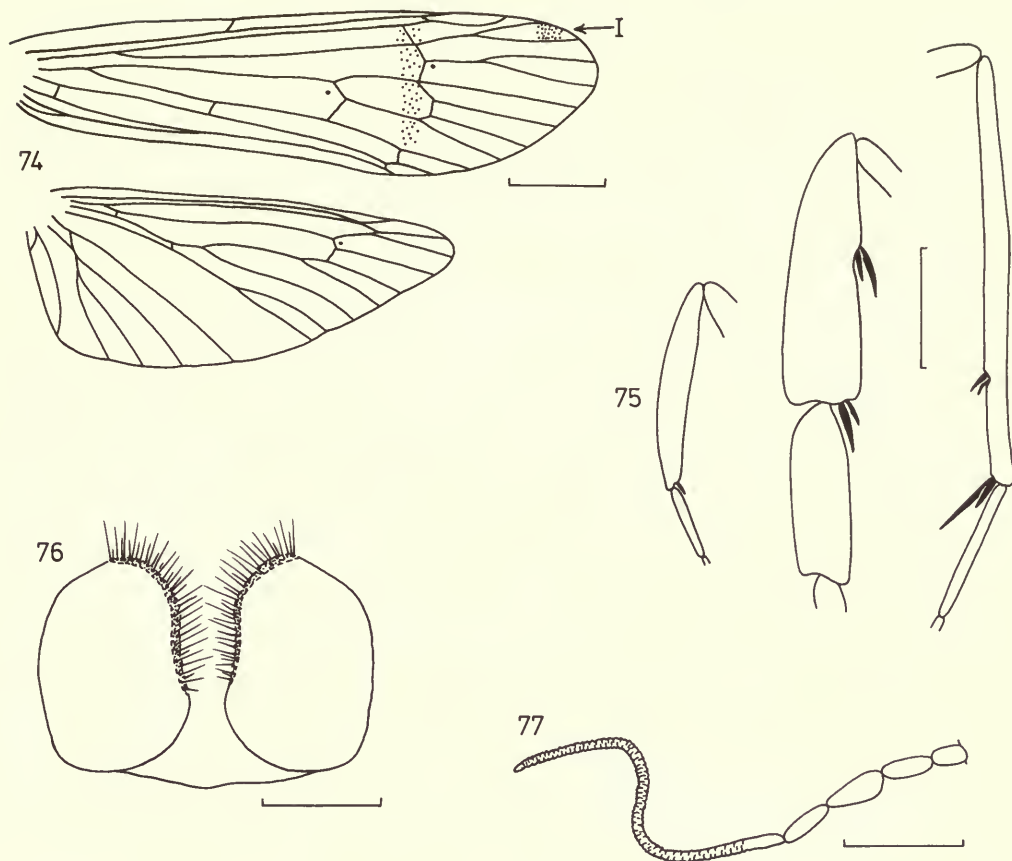

Figs 74–77 *Amphipsyche petiolata* ♀. 74. wing venation; 75, legs; 76, eighth sternites; 77, maxillary palp.

in the description of *petiolata*. However, Ulmer's species was described from females only, and the wing markings are very faint in this sex.

In addition to the distribution records below, Ulmer (1930) also recorded this species from Sumatra.

MATERIAL EXAMINED

Lectotype ♀ of *petiolata*, **Java**: Wonosobo, iv.1909 (*Jacobson*) (ZM). Lectotype ♀ of *minima*, **West Malaysia**: Kedah, nr Jitra, catchment area, 9.iv.1928 (*Pendlebury*) (BMNH). Holotype ♂ of *pubescens*, **Borneo**: Sarawak, foot of Mt Dulit, junction of Rivers Tinjar and Lejok, 20.viii.1932 (*Hobby & Moore*) (BMNH).

3 ♂, 5 ♀, **West Malaysia** (1 ♀ paralectotype of *minima*); **Borneo**: Sarawak (1 ♂, 2 ♀ paratypes of *pubescens*) (BMNH, MCZ).

The *meridiana*-group

Genae rounded, with no pubescence. Fork II sessile in fore wing. 0 spurs on fore leg; mid spurs sometimes reduced to 3 or 2; hind spurs always reduced to 3 or 2. Fifth segment of maxillary palp often reduced, or fused with 4th segment. ♂ inferior appendages slender; phallocrypt pocket and pre-anal appendages absent. Phallosome with up to three pairs of endotheal spines. Ninth segment with single (dorsal) row of setae in lateral view.

Africa, Madagascar, India, Sri Lanka, Nepal, Cambodia, West Malaysia, Sumatra, Java, Borneo, Philippines.

Amphipsyche magna Banks

(Figs 78–88)

Amphipsyche magna Banks, 1939: 58. Holotype ♂, PHILIPPINES (MCZ) [examined].

♂ (holotype only). Antennae missing, described by Banks (1939) as 'pale, tips of joints dark'. Fore wing 20mm. Head, thorax and abdomen pale yellowish brown, mesoscutellum with two round dark brown

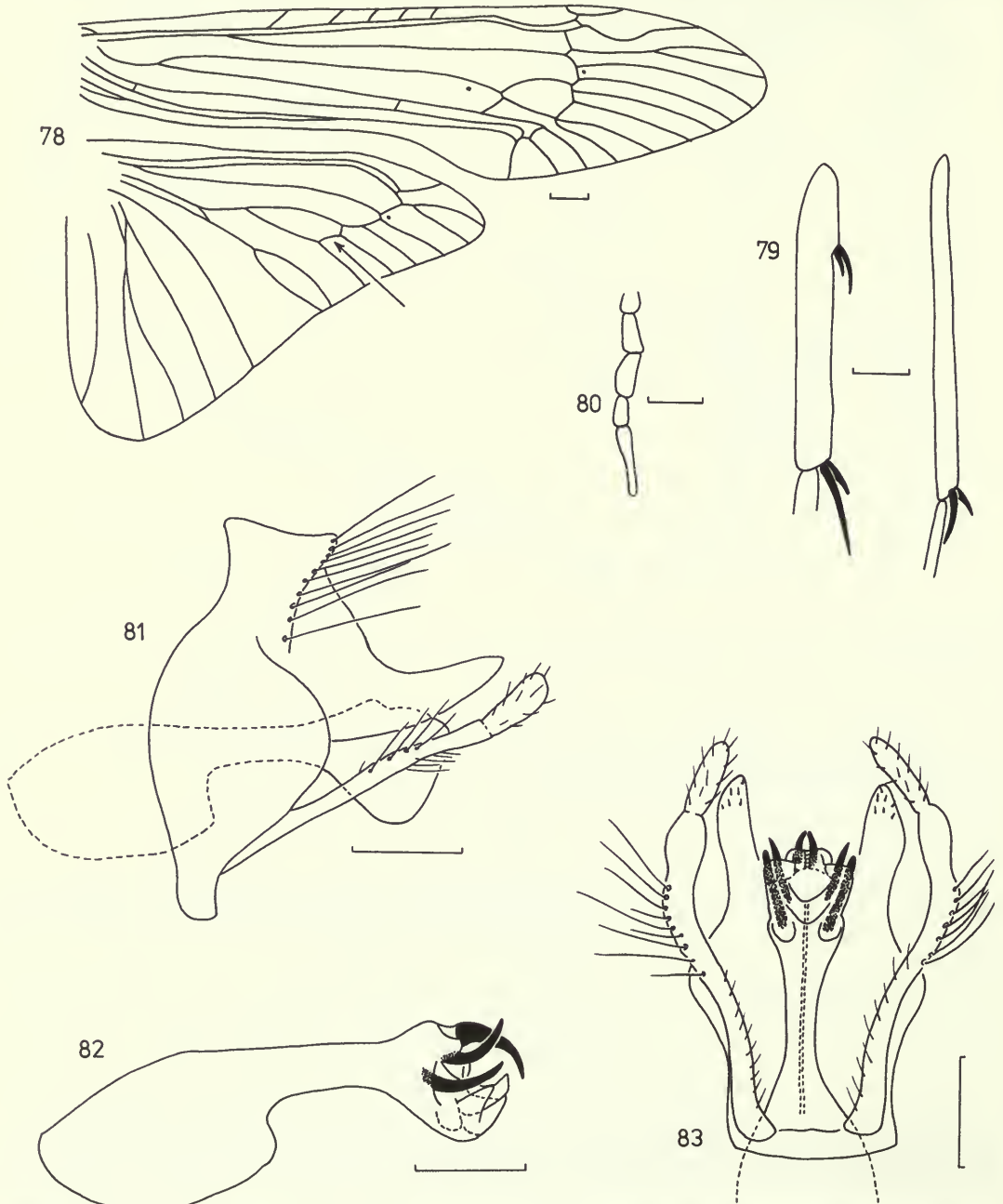

Figs 78–83 *Amphipsyche magna* ♂. 78, wing venation; 79, mid and hind tibiae; 80, maxillary palp; 81, genitalia, lateral view; 82, phallosome, lateral view; 83, genitalia, ventral view.

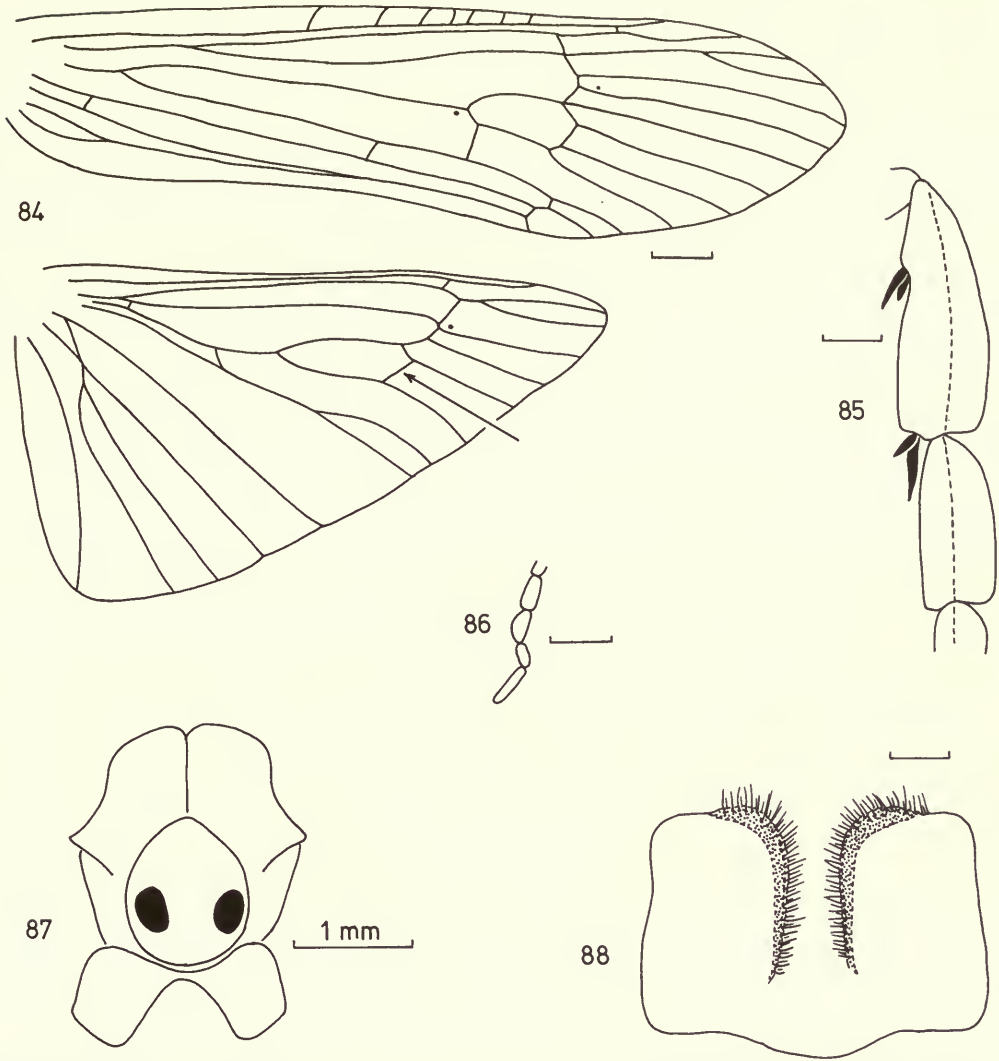

Figs 84–88 *Amphipsyche magna*. 84. ♀ wing venation; 85, ♀ mid tibia, 86, ♀ maxillary palp; 87, ♂ thorax, dorsal view; 88, ♀ eighth sternites.

markings (Fig. 87). Fore wing elongate, yellowish brown with no markings. Venation as in Fig. 78; closed median cell in hind wing formed by M_2 – M_{3+4} cross-vein. Spurs 0.4.2 (Fig. 79), not 1.4.2 as stated by Banks. Maxillary palp 5-segmented, 5th segment short, not secondarily annulated (Fig. 80).

♀ (single example). Antennal length unknown (specimen damaged). Fore wing 15 mm. Coloration as in ♂, with similar round markings on mesoscutellum. Basal antennal segments pale yellow, narrowly annulated with brown. Venation as in Fig. 84; closed median cell in hind wing as in ♂. Spurs 0.4. [? 2] (hind legs missing) (Fig. 85). Maxillary palp 5-segmented, 5th segment shorter than in ♂ (Fig. 86).

GENITALIA ♂ (Figs 81–83). Ninth segment broadly rounded laterally. Base of phallosome strongly flattened dorso-ventrally, apex rounded. Three pairs of endothelial spines present; dorsal pair directed ventrally, mid and ventral pairs curved dorsally. Inferior appendage thin and strongly sinuous; terminal segment moderately clearly differentiated.

GENITALIA ♀ (Fig. 88). Eighth sternites subrectangular, much longer than broad; inner thickened margins broad.

REMARKS. Despite the unlikely sounding combination of names, it seems that *magna*, the largest species in the genus, and *parva*, one of the smallest, are sister species. They are, of course, easily separable by the great disparity in size, and *magna* is particularly easy to recognize by the mesoscutellar markings and hind wing median cell in both sexes. Both *magna* and *parva* have the full complement of three pairs of endothecal spines and both have the unusually shaped phallosomal base, which is elongate and strongly flattened in lateral view.

This is the first description of the female of *magna*. The two striking external characters of the species, the mesoscutellar markings and the hind wing median cell, are the same in each sex, as is the reduced condition of the maxillary palps.

MATERIAL EXAMINED

Holotype ♂, **Philippines**: Luzon, Del Carmen, 15.xi.1927 (*Uichanco*) (type no. 23471, MCZ).

1 ♀, **Philippines**: Luzon (USNM).

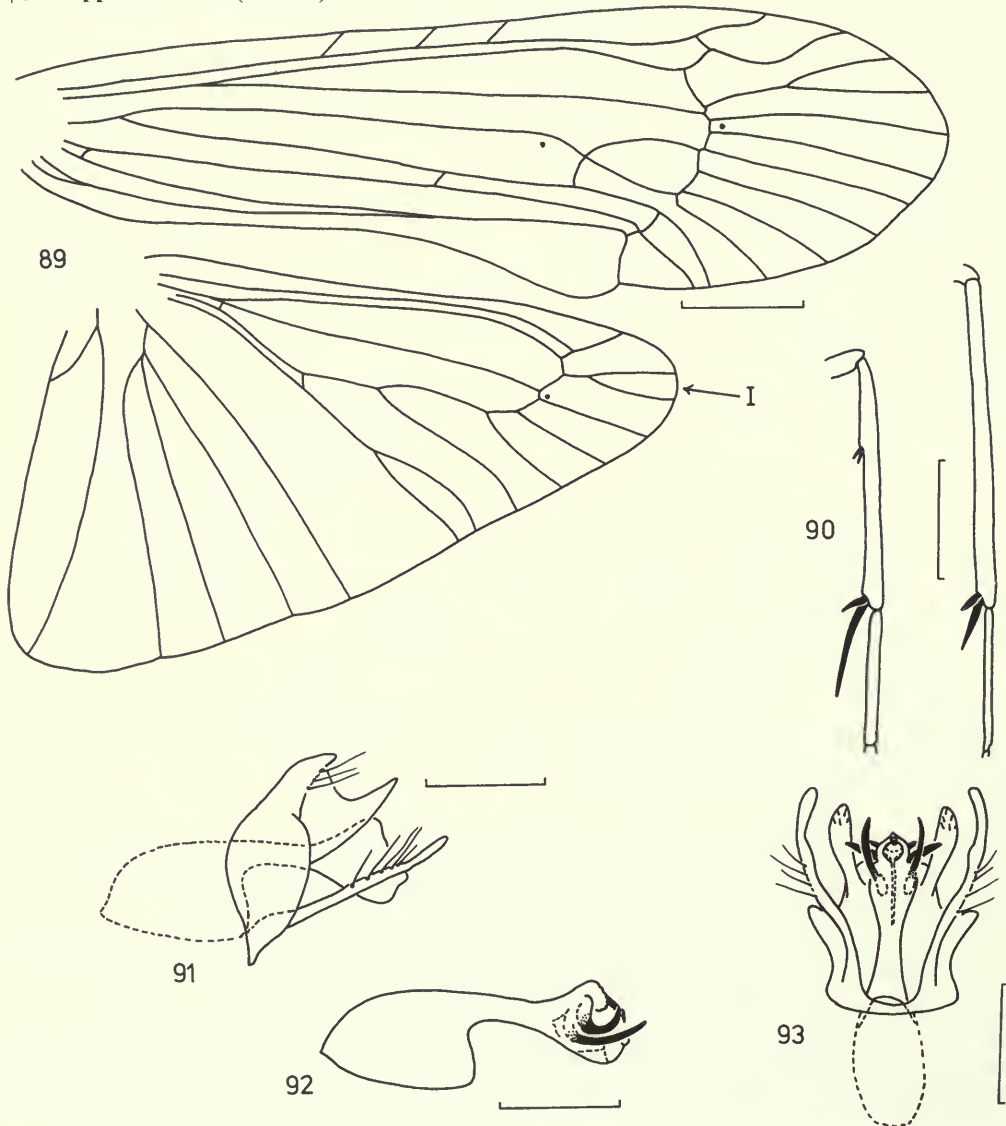

Figs 89–93 *Amphipsyche parva* ♂. 89, wing venation; 90, mid and hind tibiae; 91, genitalia, lateral view; 92, phallosome, lateral view; 93, genitalia, ventral view.

***Amphipsyche parva* Banks**

(Figs 89–93)

Amphipsyche parva Banks, 1920: 354. Holotype ♂, BORNEO (MCZ) [examined].

♂ (holotype only). Antenna *c.* 25 mm with *c.* 80 segments. Fore wing 8 mm. Antennal segments pale yellow, slightly annulated with brown. Head, thorax and abdomen yellowish brown. Fore wing very pale yellow, almost colourless, with no markings. Venation as in Fig. 89; R_1 in fore wing strongly sinuous, fork I in hind wing clearly stalked. Spurs 0.4.2 (Fig. 90). Maxillary palps missing.

♀. Unknown.

GENITALIA ♂ (Figs 91–93). Ninth segment only slightly broadened laterally. Base of phallosome strongly flattened dorso-ventrally, apex rounded. Three pairs of endothelial spines present; dorsal pair short, curved latero-ventrally; mid pair strongly curved dorsally; ventral pair long and almost straight, slightly directed dorsally. Inferior appendage thin and sinuous, terminal segment scarcely differentiated.

REMARKS. *A. parva* and *magna* are the only two species in the genus to possess three pairs of endothelial spines. *A. parva* is easily distinguished from *magna* (its sister species) by its small size and lack of thoracic markings. Little can be surmised about the maxillary palps of this species (which are missing in the holotype): although these are often reduced in the *meridiana*-group, this is not invariably the case, and the shortened apical segment in the sister species *magna* may be a unique character within this species-pair.

MATERIAL EXAMINED

Holotype ♂, **Borneo**: Mindai, vi.1882 (*Grabowsky*) (type no. 10886, MCZ).

***Amphipsyche sinhala* sp. n.**

(Figs 94–103)

♂. Antenna *c.* 35 mm, with *c.* 85 segments. Fore wing 10–12 mm. Body pale yellowish brown; basal antennal segments narrowly annulated with pale brown, apical segments fuscous. Fore wing very pale yellow with no markings; venation as in Fig. 94. Spurs 0.4.2 (Fig. 95). Maxillary palp 5-segmented; 5th segment secondarily annulated, approximately equal in length to segments 1–4 combined (Fig. 96).

♀. Antenna *c.* 14 mm, with *c.* 65 segments. Fore wing 7–8 mm. Coloration as in ♂. Venation as in Fig. 100. Spurs 0.4.2 (Fig. 101). Maxillary palp as in ♂, but 5th segment slightly shorter than segments 1–4 combined (Fig. 103).

GENITALIA ♂ (Figs 97–99). Ninth segment broad laterally. Phallosome with moderately narrow stem, broadly truncate at apex. Mid endothelial spines very short, rod-like (Fig. 98); dorsal and ventral endothelial spines absent. Inferior appendage moderately narrow, slightly sinuous; terminal segment clearly differentiated.

GENITALIA ♀ (Fig. 102). Eighth sternites narrow, outer borders strongly sloping, posterior border broadly pointed.

REMARKS. *A. sinhala* is apparently restricted to Sri Lanka, and the only other species reported from that country is *meridiana*. They can be separated easily on genitalic differences in both sexes, as well as on the spur formula; *meridiana* always has at least three spurs on the hind tibia in both sexes. Moreover, there is little overlap in size, *sinhala* being a noticeably small species. *A. sinhala* also resembles *bengalensis*, but is distinguished by the much shorter endothelial spines.

MATERIAL EXAMINED

Holotype ♂, **Sri Lanka**: Panamure, 15–21.x.1970 (*Flint*) (USNM).

Paratypes. **Sri Lanka**: 16 ♂, 36 ♀, data as holotype (all in USNM except 2 ♂, 2 ♀ in BMNH); 2 ♂, 18 ♀, Sella Kataragama, Menik Ganga, 24.x.1970 (*Flint*) (USNM).

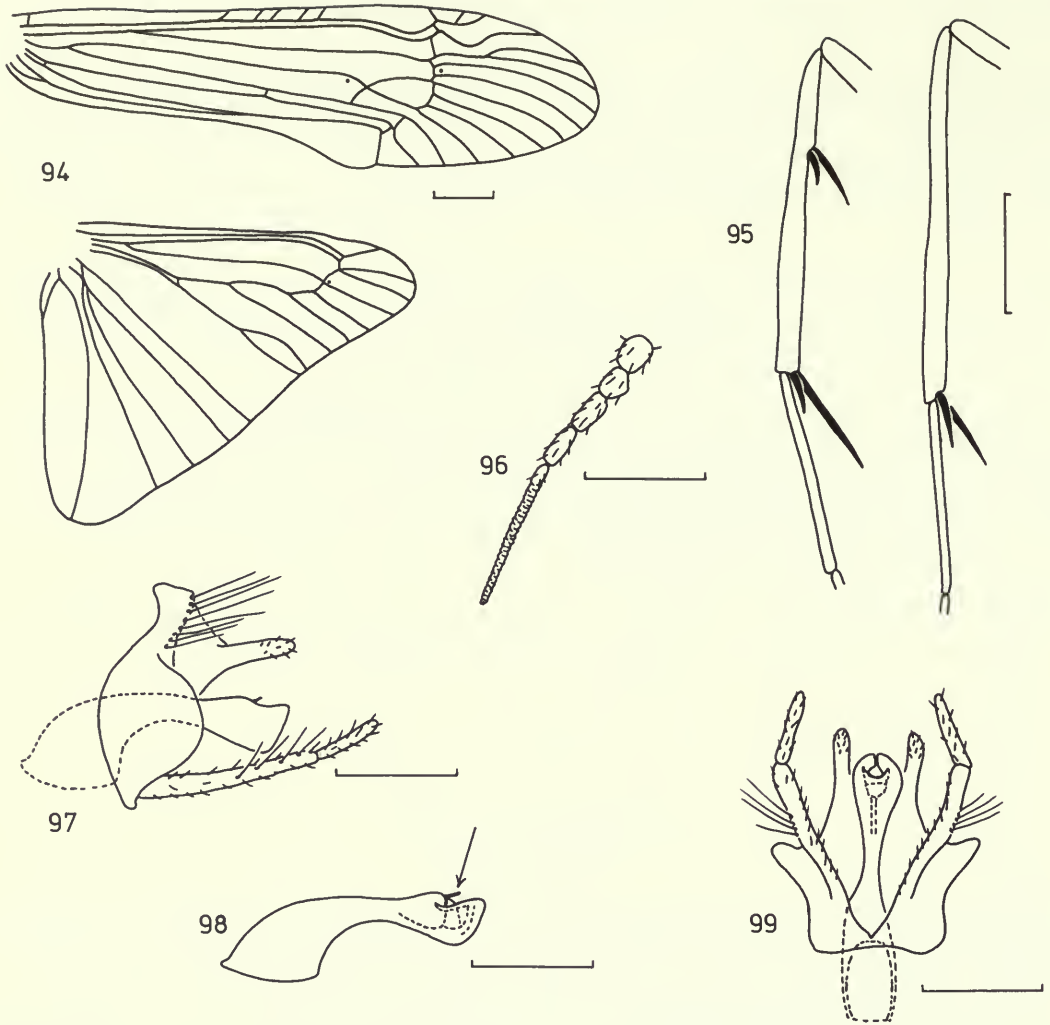

Figs 94–99 *Amphipsyche sinhala* ♂. 94, wing venation; 95, mid and hind tibiae; 96, maxillary palp; 97, genitalia, lateral view; 98, phallosome, lateral view; 99, genitalia, ventral view.

Amphipsyche meridiana Ulmer

(Figs 104–114)

Amphipsyche meridiana Ulmer, 1909: 134. LECTOTYPE ♀, JAVA (RNH), here designated [examined]. [*Phanostoma* sp. Betten, 1909: 234.]

Amphipsyche nirvana Banks, 1913: 236. Holotype ♂, INDIA (MCZ) [examined]. **Syn. n.**

Amphipsyche vedana Banks, 1913: 235. Holotype ♀, INDIA (MCZ) [examined]. **Syn. n.**

Amphipsyche [sic] *propinqua* Ulmer, 1927: 177. LECTOTYPE ♂, CAMBODIA (MNHU), here designated [examined]. **Syn. n.**

[*Amphipsyche prolata* McLachlan; Navás, 1931b: 91; 1934: 227. Misidentifications.]

Amphipsyche indica Martynov, 1935: 199. 8 syntypes, INDIA: 1 ♂, Bihar, Mokameh, at light; 1 ♂, Bihar, Dinapore, at light (*Annandale*); 2 ♂, 2 ♀, Bihar, Pusa, 5–10.xi.1915 (*Gravely*); 2 ♂, E. Bengal, Damukdia Ghat, at light on board steamer, 30.vi.1908 (2 syntypes in ZSI, the other 6 lost) [not examined]. **Syn. n.**

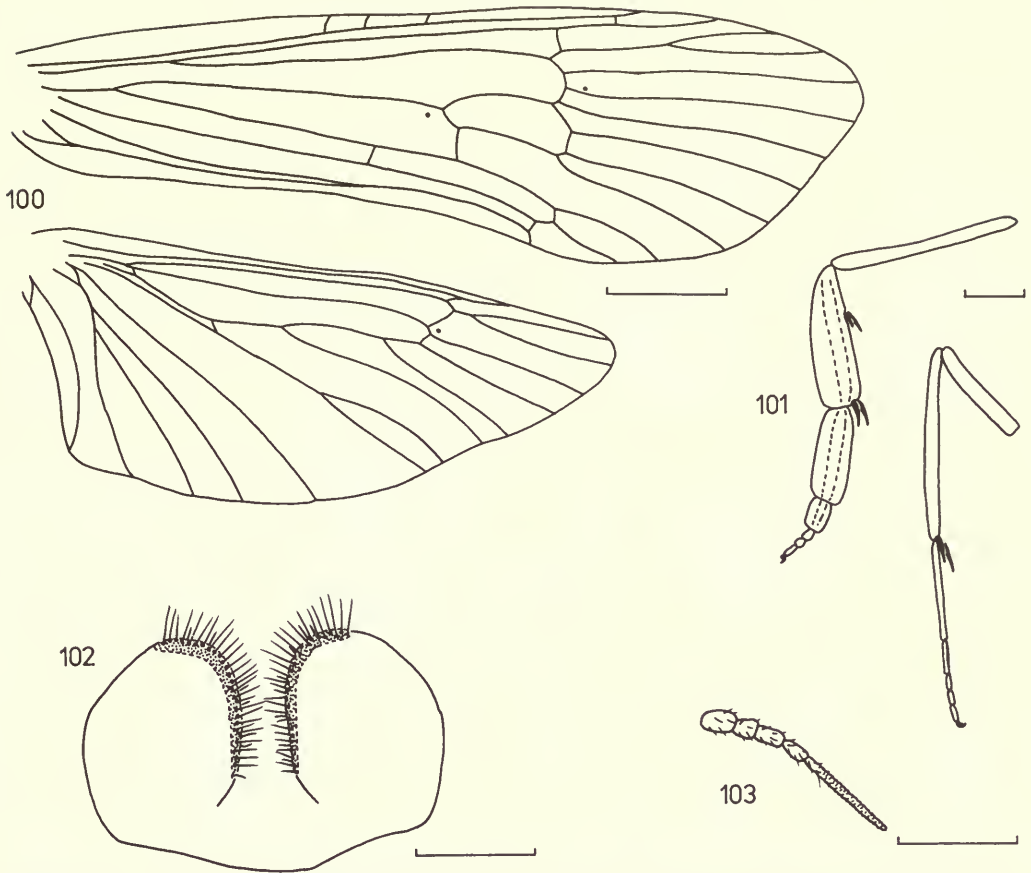

Figs 100–103 *Amphipsyche sinhala* ♀. 100, wing venation; 101, mid and hind legs; 102, eighth sternites; 103, maxillary palp.

Amphipsyche tricalcarata Martynov, 1935: 197. Holotype ♀, INDIA: Orissa, Puri district, Bhubaneswar, 4–6.xi.1912 (*Gravely*) (lost from ZSI). [Synonymized with *indica* by Schmid, 1958: 107.]

Amphipsyche sigmosa Navás, 1935: 105. LECTOTYPE ♂, INDIA (MNHN), here designated [examined].
Syn. n.

♂. Antenna *c.* 40 mm with up to 100 segments. Fore wing 13–15 mm. Body pale yellowish brown, antennal segments pale golden brown. Fore wing pale golden yellow, sometimes with pale brown marking behind R_1 – R_s cross-vein. Venation as in Fig. 105; R_1 in fore wing strongly sinuous both proximal and distal to anastomosis. Spurs 0.4.3 or 0.4.4 (pre-apical spurs on hind tibia always very small) (Fig. 106). Maxillary palp 5-segmented, 5th segment secondarily annulated, approximately equal in length to segments 1–4 combined (Fig. 107).

♀. Antenna *c.* 18 mm, with *c.* 70 segments. Fore wing 8–12 mm. Coloration as in ♂; dark marking on fore wing always absent. Venation as in Fig. 111; fork IV in fore wing occasionally stalked. Spurs (Fig. 112) and maxillary palp (Fig. 114) as in ♂.

GENITALIA ♂ (Figs 104, 108–109). Ninth segment moderately broad laterally. Phallosome elongate, with narrow stem. Dorsal endothelial spines absent, in their place a pair of semi-membranous leaf-like lobes, variable in shape (Fig. 109). Mid and ventral endothelial spines short, varying in relative length; ventral pair occasionally lost. Inferior appendage narrow and sinuous, terminal segment moderately well differentiated.

GENITALIA ♀ (Fig. 113). Eighth sternites broad and squarish with broadly rounded corners.

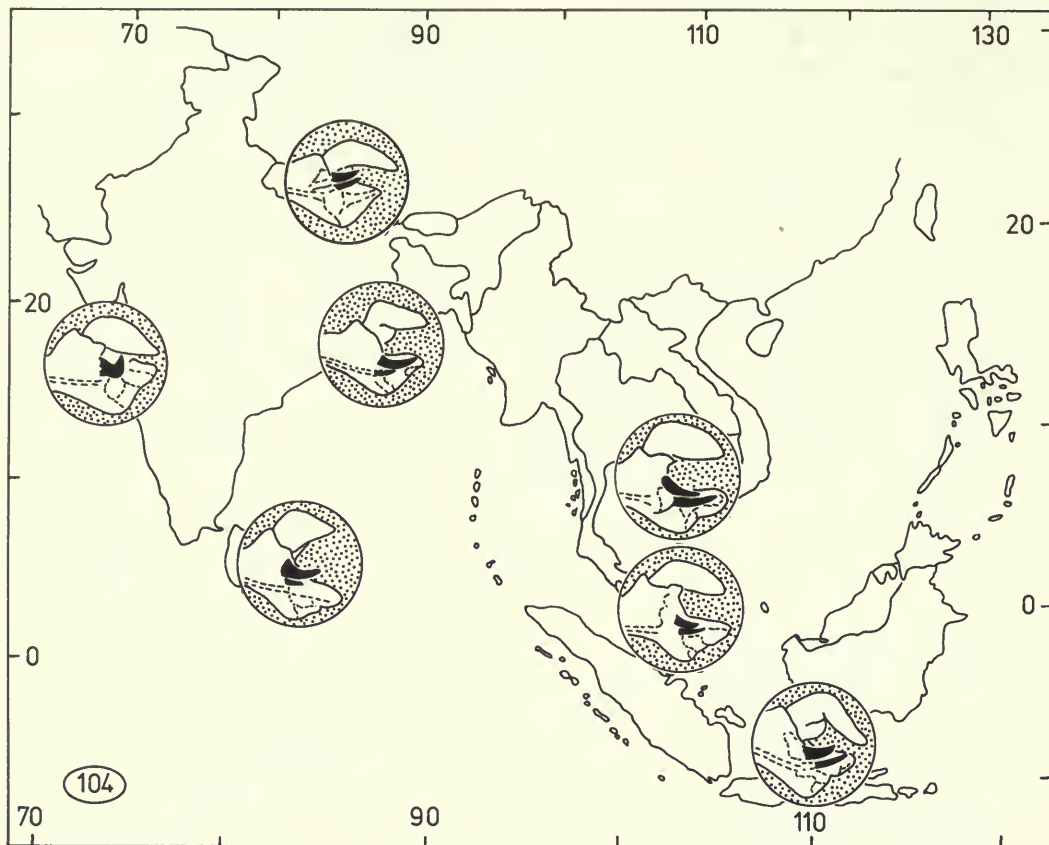
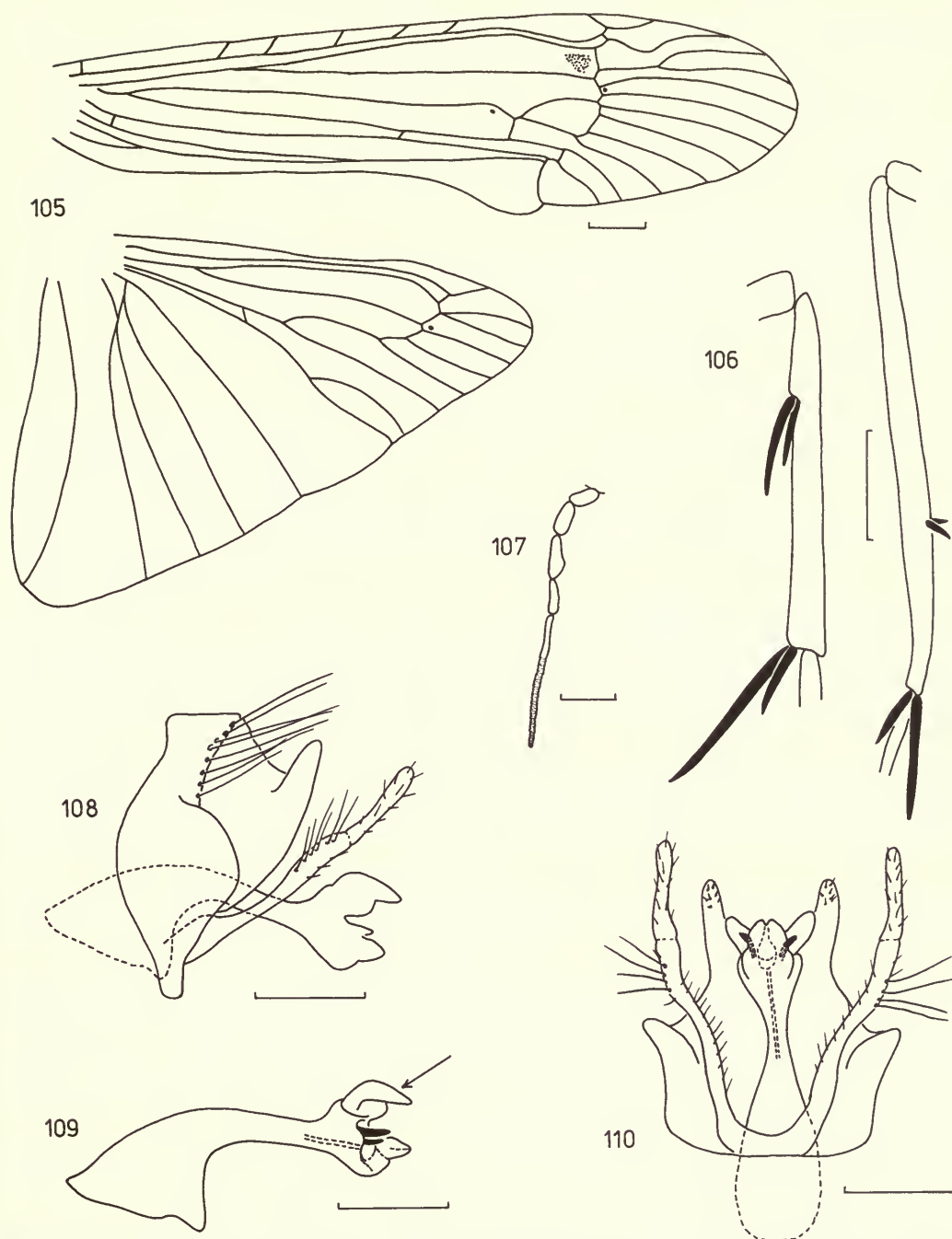

Fig. 104 Variation in ♂ genitalia of *Amphipsyche meridiana* throughout its range.

REMARKS. *A. meridiana* is the most common and widespread of the Asian species in the genus. The male is easily recognized by the dorsal leaf-like lobes on the phallosome, but the female may be confused with *sinhala* unless it is examined closely; the hind pre-apical spurs are always extremely small, thus the spur formula may be taken erroneously as 0.4.2.

The large number of synonyms of this species is partly a result of its morphological variability over a wide geographical range. Banks (1913) said that Betten's (1909) '*Phanostoma* sp.' was the same as, or very similar to, *nirvana*, and Martynov (1935) said that it was identical with his new species *indica*. Banks (1939) apparently regarded *indica* as a synonym of *nirvana*, as he placed the name *indica* in parentheses after *nirvana*. Meanwhile, Ulmer (1927) had compared *propinqua* with *nirvana* (but not with his own species *meridiana*) but later (1951) noted that *nirvana*, *propinqua* and *meridiana* were all very similar. Thus the Indian species were long considered as being synonymous, but the synonymy with *meridiana* was not suspected, partly because of the geographical separation (*meridiana* being described from Java) and partly because the male of *meridiana* was not described until 1951.

The extent of variation in the male phallosome is shown semi-diagrammatically in Fig. 104. The mid endothelial spines are moderately consistent in size and form throughout the whole range, although in the single known male from Bombay they are very short and broad, and bent abruptly upwards. However, the ventral endothelial spines vary greatly, and there seems to be a correlation with distribution, such that in the most eastern specimens they are much longer than the mid spines, whereas in the western (Indian) populations they are usually much shorter, and even lost in specimens from west India (and also occasionally Sri Lanka). There is in fact a discontinuity in the distribution of this species, with no specimens known from countries



Figs 105–110 *Amphipsyche meridiana* ♂. 105, wing venation; 106, mid and hind tibiae; 107, maxillary palp; 108, genitalia, lateral view; 109, phallosome, lateral view; 110, genitalia, ventral view.

between India and Cambodia. There may be justification for considering the two populations as subspecifically distinct, in which case the Indian subspecies would have to be named *meridiana nirvana*, with the nominate subspecies in South East Asia, but I do not propose such a formal division at present.

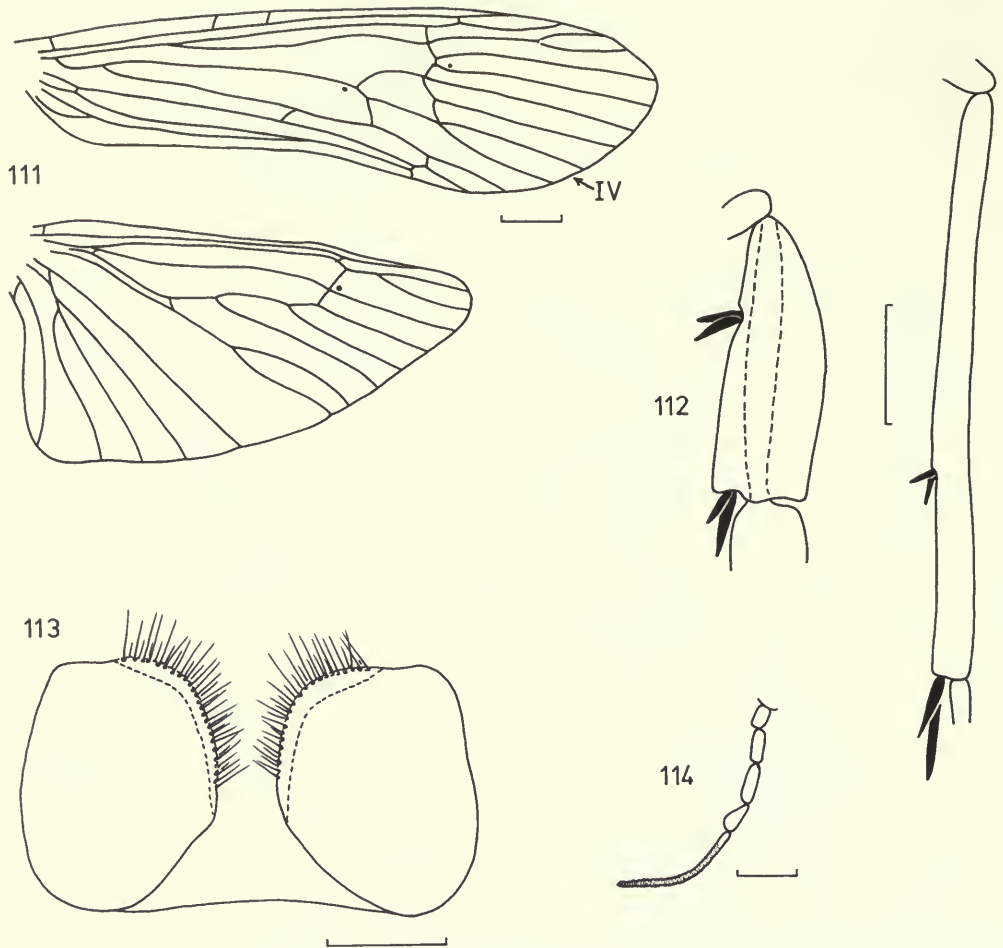

Figs 111–114 *Amphipsyche meridiana* ♀. 111, wing venation; 112, mid and hind tibiae; 113, eighth sternites; 114, maxillary palp.

I do not believe that the 'paratype' of *meridiana* mentioned by Weidner (1964) has any type-status. Although from the type-locality, it bears a printed label with the date 'Dec. 1908'. A 'Paratype' label has also been attached, bearing the hand-written date '8.1907', not in Ulmer's hand, to conform to the published type-data. However, the other labels do not match those on the two remaining syntypes in Leiden; of the original three syntypes mentioned by Ulmer in the RNH, one has apparently been lost (Geijskes, *in litt.*).

Of the three syntypes of *propinqua* described by Ulmer (1927) I have examined the two males in MNHU and designate as lectotype the one labelled 'type' by Ulmer. The third male syntype, now a paralectotype (IP, not examined), lacks its abdomen (Director, IP, *in litt.*).

I was informed by Ghosh (*in litt.*) of the apparent loss of six syntypes of *indica*, and of the holotype of *tricalcarata* from the ZSI. The female syntypes of *sigmosa* (from Khandala) are also apparently lost, so the sole remaining male syntype in the MNHN is here designated as lectotype.

The larva of this species was described by Hafiz (1937, as *indica*), and by Ulmer (1957). There are some differences between these two descriptions, both in the gill formulae and in the head markings. Specimens from Java that I have examined differ slightly in gill counts from Ulmer's description, even though his material was also from Java (and Sumatra). Some aspects of the life

history are described by Seshadri (1955) and Boon (1979) – see p. 79. Some specimens in the BMNH, received via the Commonwealth Institute of Entomology, were captured on paddy-fields in India, but any economic significance of this is unknown.

MATERIAL EXAMINED

Lectotype ♀ of *meridiana*, **Java**: Batavia, viii.1907 (*Jacobson*) (RNH). Holotype ♂ of *nirvana*, **India**: Bengal, Pusa, at light, 23.iii.1908 (type no. 11755, MCZ). Holotype ♀ of *vedana*, **India**: Bengal, Pusa, 15.ix.1907 (type no. 11757, MCZ). Lectotype ♂ of *propinqua*, **Cambodia**: Mekong, Pnom-Pech, i.1914 (*Friederichs*) (MNHU). Lectotype ♂ of *sigmosa*, **India**: Bombay, Lonawla [= Lonavla, = Lonauli], 9.x.1934 (*Benavent*) (MNHN).

229 ♂, 332 ♀, c. 75 larvae, 2 pupae, **India, Sri Lanka, Nepal, Cambodia** (1 ♂ paralectotype of *propinqua*), **West Malaysia, Sumatra, Java** (1 ♀ paralectotype and 1 ♀ as 'paratype' of *meridiana*; see 'Remarks' above) (BMNH, MCZ, MNHU, RNH, USNM, ZM).

Amphipsyche bengalensis Martynov

(Figs 117, 118)

Amphipsyche bengalensis Martynov, 1935: 201. 2 ♂ syntypes, **INDIA**: Bengal, Calcutta, at light, 19.vi.1907 (*Hodgart*) (ZSI) [not examined].

♂ (from Martynov, 1935). 'Body pale yellow. Antennae yellow, with narrow dark annulations. Anterior wings pale. R[R₁] curved in its apical portion even more strongly than in *A. indicum* [= *meridiana*]. . . . In posterior wings first (apparently false) fork sessile, not pedicellate; . . . formula of spurs 1.4.2 [probably 0.4.2]. Length of body 6 mm.'

♀. Unknown.

GENITALIA ♂ (Figs 117, 118) (from Martynov, 1935). '10th [9th] segment as in [*meridiana*], but its side-lobes appear to be somewhat broader. Lower end-lobe of the penis [phallosome] broader, distinctly excised in the middle and curved upwards (if seen from side); upper leaf-like lobes lacking, in their place is an oval elevation, behind which are situated two stick-shaped appendages [mid endothelial spines]; underside of the penis thickened before its lower end-lobe.'

REMARKS. This species seems to be most closely related to *sinhala*, but the male genitalia are different, assuming Martynov's figures to be accurate. Although Martynov gave no wing-length for *bengalensis*, this would also seem to be a larger species than *sinhala*, whose body length is

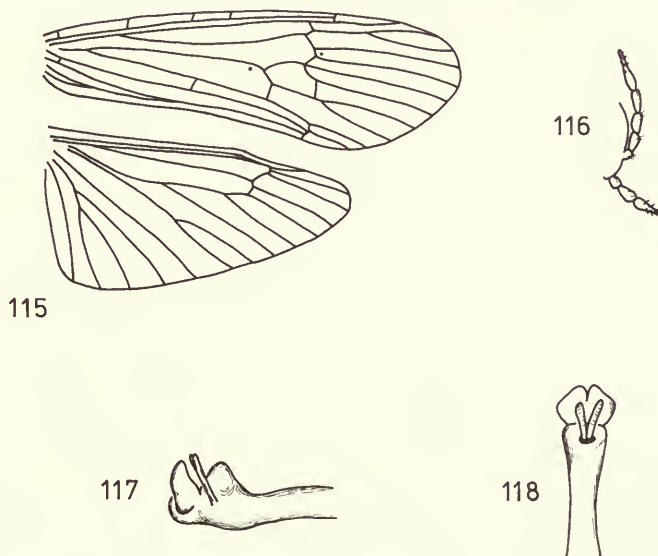

Figs 115–118 115, 116, *Amphipsyche extrema* ♀, (115) wing venation; (116) palps. 117, 118, *Amphipsyche bengalensis* ♂, (117) phallosome, lateral view; (118), phallosome, dorsal view. (After Martynov.)

only 4–5 mm. The 6 mm body length of *bengalensis* suggests that it is of a similar size to *meridiana*. The spur formula of this species should almost certainly be 0.4.2; Martynov probably mistook an apical seta on the fore tibia for a spur.

The two syntypes in the ZSI are damaged (Ghosh, *in litt.*) and I was unable to examine them. The species is known only from these two specimens from Bengal.

***Amphipsyche extrema* (Martynov) comb. n.**

(Figs 115, 116)

Amphipsychella extrema Martynov, 1935: 202. 2 syntypes, INDIA: 1 ♀, Bengal, Calcutta, Eden Garden, at light, 26.v.1912 (*Gravelly*); 1 ♀, Bengal, Calcutta, v.1915 (*Gravelly*) (both lost from ZSI).

♂. Unknown.

♀ (from Martynov, 1935). 'Pale yellow. Antennae very slender, yellowish, with narrow darker annulations. Maxillary palpi very short, not reaching eyes; 2–4 joints subequal; 5th joint shorter than 3rd and 4th combined, its distal half slender and but very indistinctly annulated; labial palpi also very short [Fig. 116] . . . In anterior wings [Fig.115] three false veinlets are seen between C and Sc; 1st apical fork a little longer than its pedicel and somewhat approximated to R [R_1]; R long, slightly arcuate; . . . 4th apical fork with a short pedicel. RS_{1+2} in posterior wings simple, not united at its base with RS_3 . Abdomen pale. Length of body 5.5 mm.' [From generic diagnosis of *Amphipsychella*] 'Spurs 0.2(1).2, the outer spur on the median legs reduced, indistinct.'

REMARKS. It is difficult to comment on the relationships of this species, as it is known only from the female which I have not examined; apparently both syntypes are lost from the ZSI (Ghosh, *in litt.*). However, the highly reduced spur formula, and the shortened maxillary palp place it in the *meridiana*-group. It would seem most closely related to *bengalensis*, *meridiana* and *sinhala*, but can be distinguished from these other Indian species by the spur formula and the maxillary palp.

***Amphipsyche senegalensis* (Brauer)**

(Figs 120–129; distribution, Fig. 119)

Phanostoma senegalense Brauer, 1875: 71. Lectotype ♂, SENEGAL (NM), designated by Kimmins, 1962: 86 [examined].

Phanostoma curvinerve Navás, 1927: 214. LECTOTYPE ♀, EGYPT (USNM), here designated [examined].

Syn. n.

Amphipsyche senegalensis (Brauer) Kimmins, 1962: 85.

♂. Antenna *c.* 40 mm, with *c.* 75 segments. Fore wing 11–17 mm. Body pale yellowish brown, antenna narrowly annulated with brown. Fore wing pale yellow, often with brownish wedge-shaped pterostigmal marking; venation as in Fig. 120. Spurs 0.4.2 (Fig. 121). Maxillary palp 5-segmented; 5th segment secondarily annulated, slightly longer than segments 1 and 2 combined (Fig. 122).

♀. Antenna *c.* 15 mm, with *c.* 65 segments. Fore wing 9–12 mm. General coloration as in ♂. Fore wing usually unmarked, rarely with pale brown pterostigmal marking; venation as in Fig. 126; *Rs* in fore wing strongly sinuous. Spurs 0.2.2, 0.3.2 (Fig. 127) or 0.4.2. Maxillary palp similar to that of ♂; 5th segment approximately equal to 1 and 2 combined (Fig. 129).

GENITALIA ♂ (Figs 123–125). Ninth segment broadly rounded laterally. Base and stem of phallosome narrow, apex bluntly rounded; no endothecal spines present. Inferior appendage slender; terminal segment moderately well differentiated.

GENITALIA ♀ (Fig. 128). Eighth sternites broadly rounded; slight indentation in middle of posterior edge, and outer posterior corners produced.

REMARKS. This species is easily distinguished from the other African species by the complete absence of endothecal spines in the male. The female can probably be distinguished by the very sinuous *Rs* in the fore wing, but this cannot be confirmed until the females of all the African species have been discovered. *A. senegalensis* has a very wide distribution, being found in virtually every country in the Afrotropical region except in the south-west and along the east

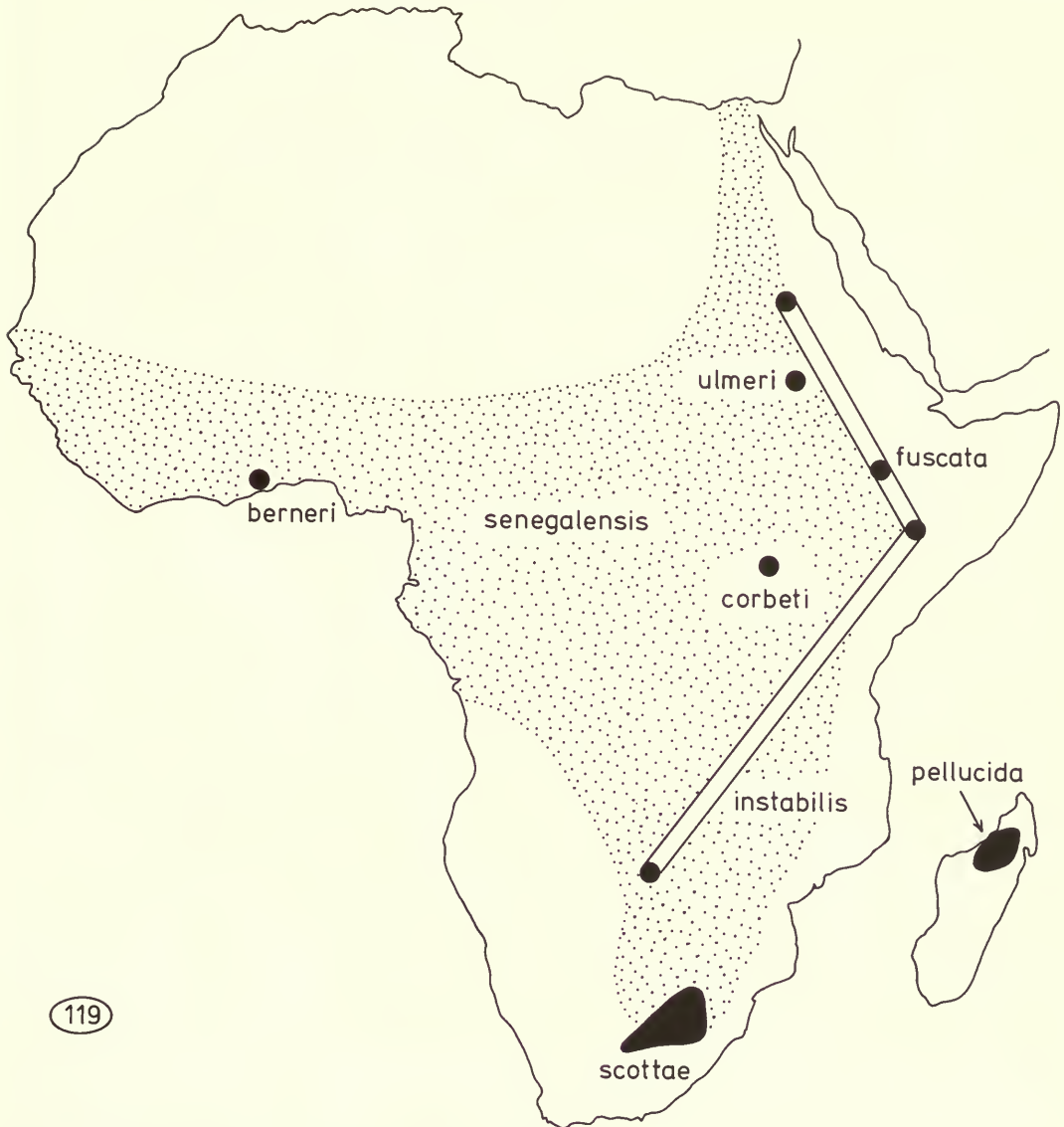

119

Fig. 119 Distribution of the African species of *Amphipsyche*.

coast (Fig. 119); this distribution coincides closely with the distribution of permanent waters in Africa (Gourou, 1970). The species is often caught in very large numbers, especially at light.

The synonymy of *curvinerve* with *senegalensis* was suspected by Kimmins (1962); the only remaining syntype of *curvinerve*, from the Alfieri collection, now in the USNM, has genitalia indistinguishable from those of typical *senegalensis*. Ulmer (1963) retained the name *curvinerve* when describing the larva of this species, but he admitted that he could not separate the two species. Ulmer had seen no females from West Africa to compare with his Egyptian examples, and he rightly suspected that his Sudanese specimens represented a different species: this was described as *ulmeri* by Kimmins (1962).

The female figured by Savigny (1813) from Egypt is certainly this species, though not named; this was the first published figure of a species of *Amphipsyche*.

The larva of *senegalensis* was described by Hickin (1955), Jacquemart (1957), Marlier (1962)

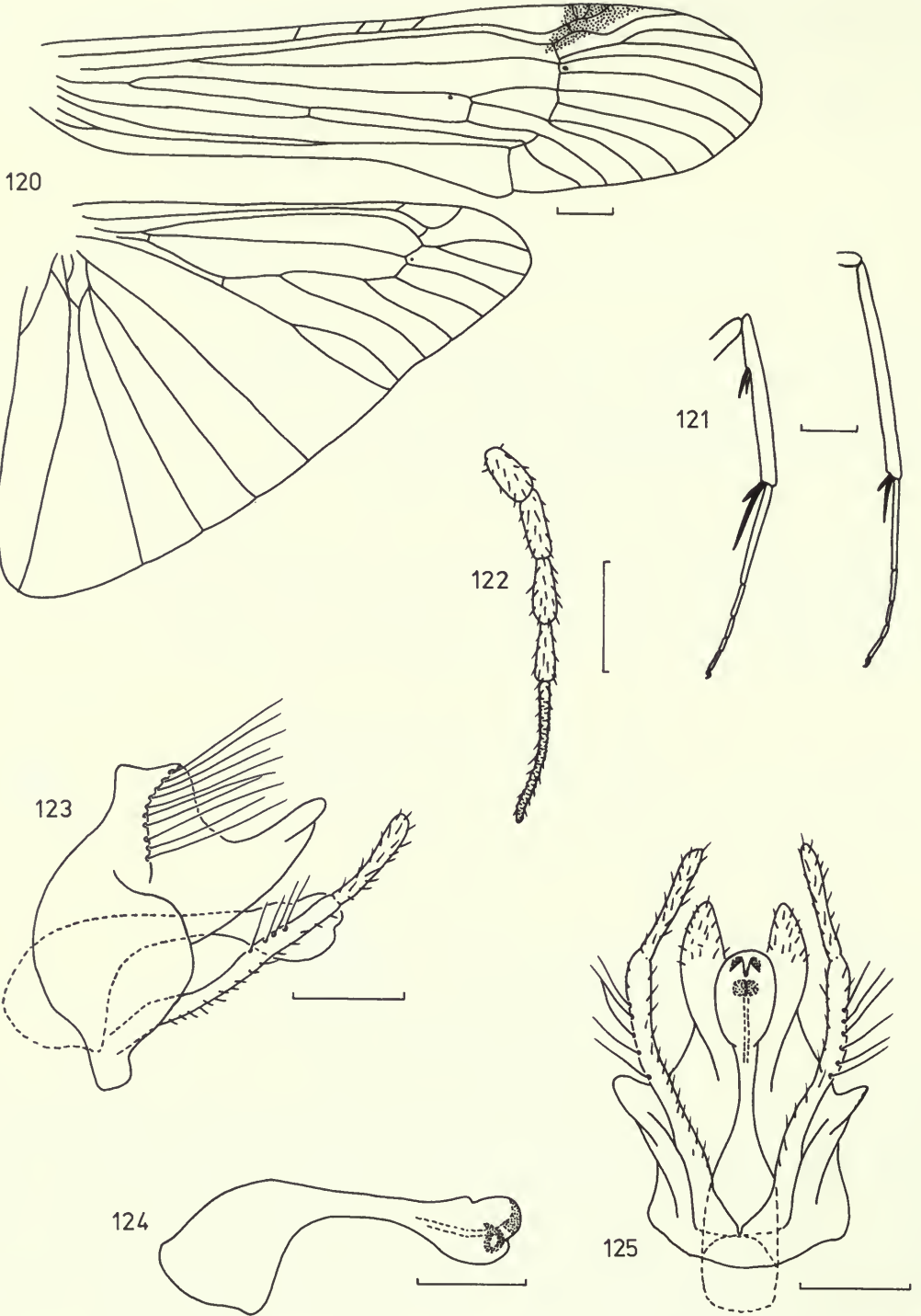

Figs 120–125 *Amphipsyche senegalensis* ♂. 120, wing venation; 121, mid and hind legs; 122, maxillary palp; 123, genitalia, lateral view; 124, phallosome, lateral view; 125, genitalia, dorsal view.

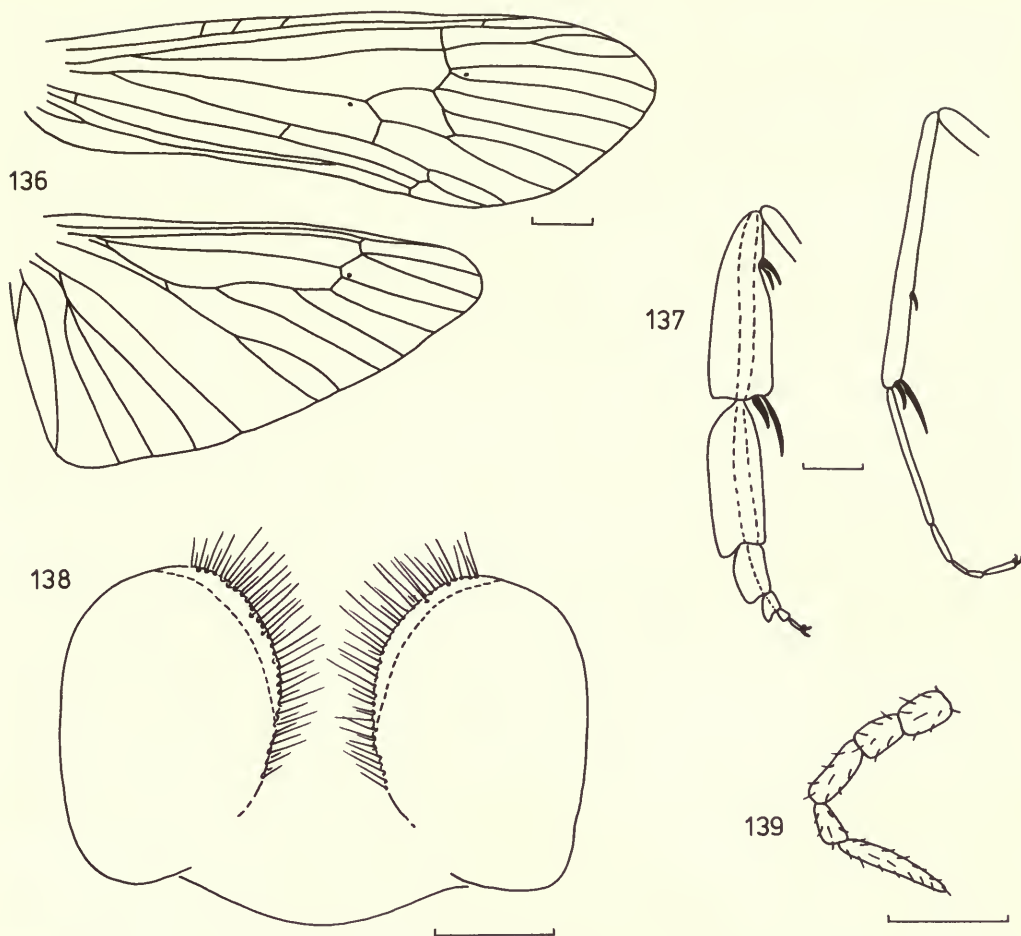

Figs 136–139 *Amphipsyche pellucida* ♀. 136, wing venation; 137, mid and hind legs; 138, eighth sternites; 139, maxillary palp.

REMARKS. Although this species clearly belongs in the ‘African’ section of the *meridiana*-group, it has no close affinities with any other species. It is the only species found in Madagascar, and morphologically the form of the phallosome renders it easily identifiable. This is the first time that the male has been described.

Navás (1923) mis-read the type-locality of *pellucida* as ‘Maeratanana’; this also applies to other species described in the same paper.

MATERIAL EXAMINED

Holotype ♀, **Madagascar**: Maevatanana [no further data] (MNHN).

3 ♂, 13 ♀. **Madagascar** (BMNH, USNM).

***Amphipsyche instabilis* Kimmins**

(Figs 140–150; distribution, Fig. 119)

Amphipsyche instabilis Kimmins, 1963: 126. Holotype ♂, ETHIOPIA (BMNH) [examined].

Phanostoma plicata Jacquemart, 1963: 363. LECTOTYPE ♂, ZIMBABWE (ZI), here designated [examined]. **Syn. n.**

♂. Antenna up to 33 mm, with c. 90 segments. Fore wing 11–14 mm. Body pale yellowish brown, antennal

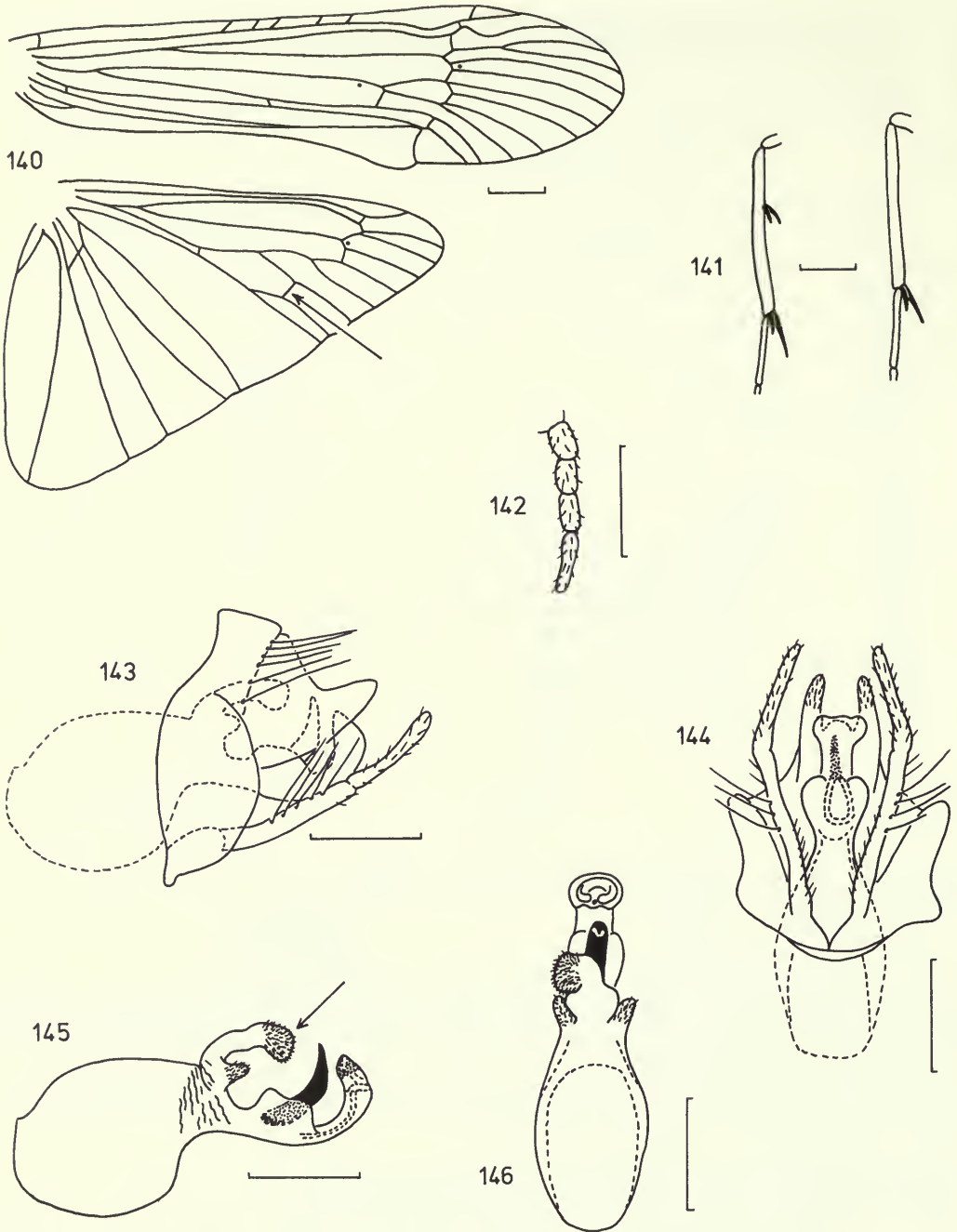

Figs 140–146 *Amphipsyche instabilis* ♂. 140, wing venation; 141, mid and hind tibiae; 142, maxillary palp; 143, genitalia, lateral view; 144, genitalia, ventral view; 145, phallosome, lateral view; 146, phallosome, dorsal view.

segments becoming gradually more fuscous towards apex, narrowly annulated with brown. Fore wing pale yellow with no markings; venation as in Fig. 140; cross-vein present between M_{3+4} and Cu_{1a} in hind wing. Apical venation often irregular in both fore and hind wings. Spurs 0.4.2 (Fig. 141). Maxillary palp 4-segmented, apical segment short and not secondarily annulated (Fig. 142).

♀ (allotype only). Antennal length unknown (specimen damaged). Fore wing 9 mm. Coloration as in ♂, venation as in Fig. 147; cross-vein between M_{3+4} and Cu_{1a} in hind wing as in ♂. Spurs 0.2.2 (Fig. 148). Maxillary palp 4-segmented (Fig. 149), similar to that of ♂.

GENITALIA ♂ (Figs 143–146). Ninth segment only moderately broad laterally. Base of phallosome very large and rounded, stem short and greatly thickened; dorsal clavate process present, with curved stem, apex covered with fine spines (Fig. 145); on either side of process a similarly spinose triangular lobe. Mid endothelial spines fused to form single median spine, very thick and curved dorsally. Lower apex of phallosome elongate, curved dorsally, extreme apex globular. Inferior appendage narrow, slightly sinuate; terminal segment moderately well differentiated.

GENITALIA ♀ (Fig. 150). Eighth sternites broad and squarish, with rounded indentation in posterior edge; inner thickened edges narrow.

REMARKS. Although this species is closely related to the other African species of the genus, it is easily recognized. Externally, both sexes are easily identified by the extra cross-vein between M_{3+4} and Cu_{1a} in the hind wing which is unique amongst the African species, though paralleled in *proluta*, the type-species of the genus. The male genitalia are highly distinctive; the elongate dorsal process and single median endothelial spine are not found in any other species. The only known female closely resembles the female of *senegalensis*, which is found in the same locality, but apart from the venational character already mentioned, it can easily be distinguished by the 4-segmented maxillary palp and the squarish eighth sternites.

The specimen here designated as lectotype of *plicata* was labelled 'type' by Jacquemart, and the paralectotypes as 'paratypes', but these designations were not published.

Although the descriptions of *instabilis* and *plicata* were published in the same year, there is no doubt that Kimmins's appeared first. His paper was officially published on 20th February 1963 and, according to data in the BMNH Entomology Department Library, it was definitely available before the end of that month. The book in which Jacquemart's paper appeared has no exact date of publication, but the copy in the BMNH Zoology Department Library was received

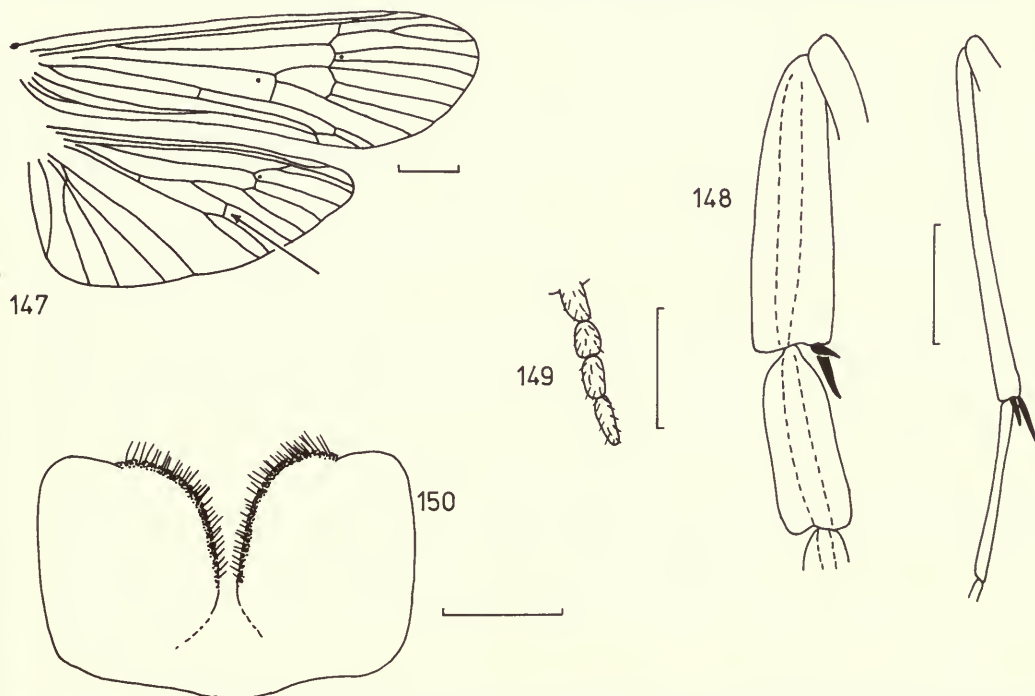

Figs 147–150 *Amphipsyche instabilis* ♀. 147, wing venation; 148, mid and hind tibiae; 149, maxillary palp; 150, eighth sternites.

on 11th October 1963. Further enquiries to the ZI revealed that their copy was received on 25th November 1963 (Tjeder, *in litt.*), and the copy in the Kungliga Biblioteket, Stockholm (the Swedish copyright library) was not received until February 27th 1964 (Lilliestam, *in litt.*). It seems certain, therefore, that the description of *plicata* was not published until at least October 1963, and that the name *instabilis* has priority.

MATERIAL EXAMINED

Holotype ♂ of *instabilis*, **Ethiopia**: Dawa River, 12 km N. of Hudat, 12.iv.1961 (*Tjønneland*) (slide preparation, BMNH). Lectotype ♂ of *plicata*, **Zimbabwe**: Victoria Falls, 16.v.1951 (slide preparation, ZI).

38 ♂, 1 ♀, **Ethiopia** (18 ♂ paratypes of *instabilis* and 1 ♀ allotype inadvertently labelled as '♂ paratype' by Kimmins), **Zimbabwe** (5 ♂ paralectotypes of *plicata*), **Zambia** (BMNH, IRSNB, USNM, ZI).

Amphipsyche ulmeri Kimmins

(Figs 151–154; distribution, Fig. 119)

[*Phanostoma senegalense* Brauer; Ulmer, 1923: 19 (*partim* – specimens from Sennar only); 1924: 2. Misidentifications.]

Amphipsyche ulmeri Kimmins, 1962: 89. Holotype ♂, SUDAN (NM) [examined].

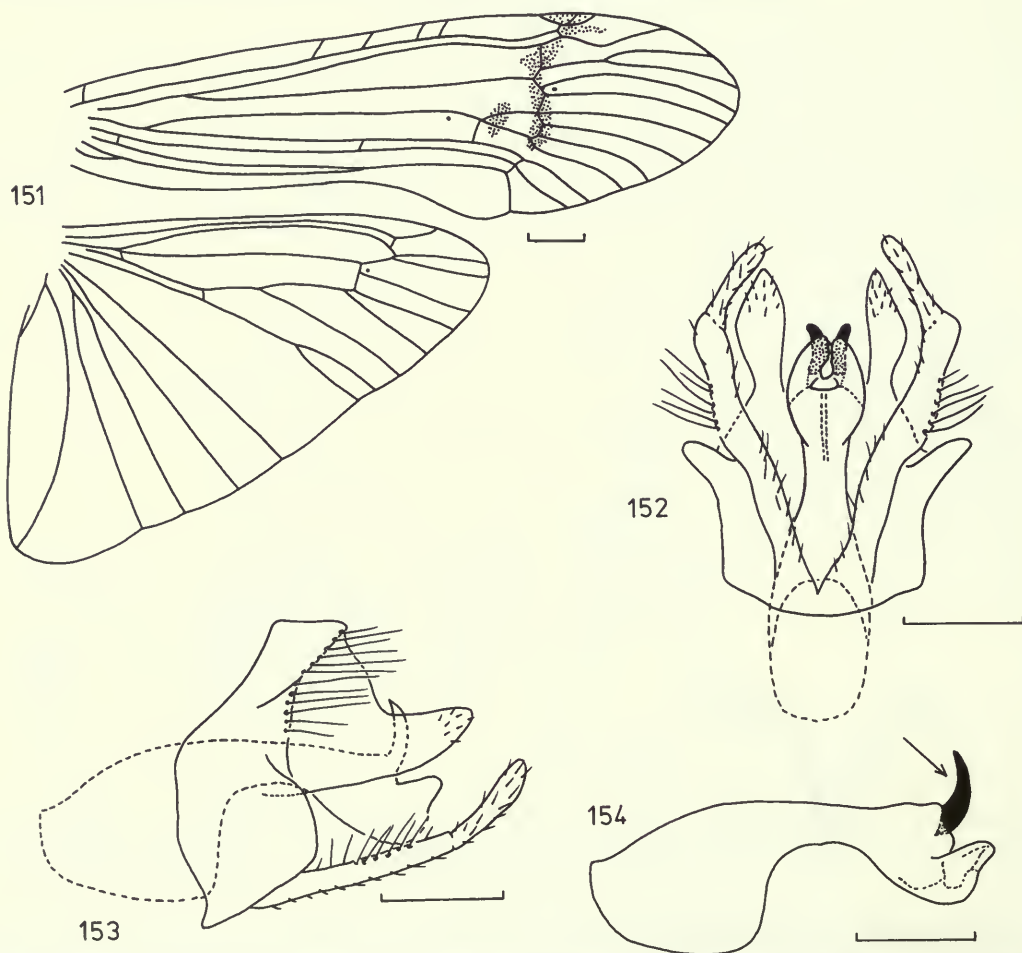

Figs 151–154 *Amphipsyche ulmeri* ♂. 151, wing venation; 152, genitalia, ventral view; 153, genitalia, lateral view; 154, phallosome, lateral view.

♂ (holotype only). Antenna 32 mm, with c. 70 segments. Fore wing 14 mm. Antennal segments pale golden brown, annulated with dark brown. Head, thorax and abdomen yellowish brown. Fore wing pale yellow with indistinct brownish shading across anastomosis; venation as in Fig. 151. Spurs 0.4.2. Maxillary palp as in *senegalensis* (cf. Fig. 122).

♀. No specimens seen, but see 'Remarks' below.

GENITALIA ♂ (Figs 152–154). Lateral part of ninth segment broad and squarish. Base of phallosome broad, extreme apex bluntly pointed; mid endothelial spines long and stout, curved abruptly dorsally (Fig. 154). Inferior appendage strongly sinuous in ventral view, terminal segment moderately well differentiated.

REMARKS. *A. ulmeri* and *scottae* are closely related, despite their widely separate distributions (Fig. 119), both species having very similar male genitalia. However, *ulmeri* can be distinguished by the sharply up-turned mid endothelial spines.

Kimmins (1962) mentioned the existence of females from the type-locality, Sennar, in Ulmer's collection. Subsequently Ulmer (1963) described these females as being distinguishable from Egyptian females of *curvinerve* (= *senegalensis*) by the less sinuous *Rs* in the fore wing and the spur formula of 0.3.2. It is quite probable that these are females of *ulmeri*, but the spur formula is not significant, as Kimmins (1963) showed that there is great variation in the spurs of female *senegalensis*, 0.3.2 occurring in that species also.

MATERIAL EXAMINED

Holotype ♂, Sudan: Sennar, 18–27.ii.1914 (Ebner) (NM).

Amphipsyche scottae Kimmins

(Figs 155–164; distribution, Fig. 119)

Amphipsyche scottae Kimmins, 1962: 93. Holotype ♂, SOUTH AFRICA (BMNH) [examined].

♂. Antenna c. 45 mm, with c. 95 segments. Fore wing 16–19 mm. Body yellowish brown, antenna narrowly annulated with brown, segments becoming more fuscous towards apex. Fore wing pale yellow, with slightly darker area along costa and near *Sc-R*₁ cross-vein, often indistinct. Venation as in Fig. 155. Spurs 0.4.2 (Fig. 156). Maxillary palp 5-segmented, 5th segment approximately equal in length to segments 1 and 2 combined, not secondarily annulated (Fig. 157).

♀. Antenna c. 20 mm, with c. 70 segments. Fore wing 14–15 mm. General coloration as in ♂; fore wing with no darker markings. Venation as in Fig. 161. Spurs 0.4.2 (Fig. 162). Maxillary palp similar to that of ♂, but 5th segment shorter (Fig. 164).

GENITALIA ♂ (Figs 158–160). Ninth segment broadly rounded laterally. Base of phallosome broadly triangular, with pronounced corner on dorsal side. Ventral apex forming pair of rounded lobes; extreme apex bluntly pointed (Fig. 159). Mid endothelial spines long, curved dorsally. Inferior appendage slender, terminal segment moderately well differentiated.

GENITALIA ♀ (Fig. 163). Eighth sternites broad and squarish, with slight indentation in middle of posterior edge. Inner thickened margin extending far towards anterior edge.

REMARKS. *A. scottae* most closely resembles *ulmeri* in that the males of both species have the tip of the phallosome bluntly pointed in lateral view, but *scottae* can be distinguished by the gently curved mid endothelial spines, which are sharply up-turned in *ulmeri*.

The larva of this species was described by Scott (in press), and some aspects of its biology are mentioned by Chutter (1963; 1968); see p. 79.

MATERIAL EXAMINED

Holotype ♂, South Africa: Natal, Wilge R., 5 miles [8 km] below Harrismith, 10.ii.1959 (slide preparation, BMNH).

12 ♂, 2 ♀, South Africa (12 ♂, 1 ♀ paratypes) (BMNH).

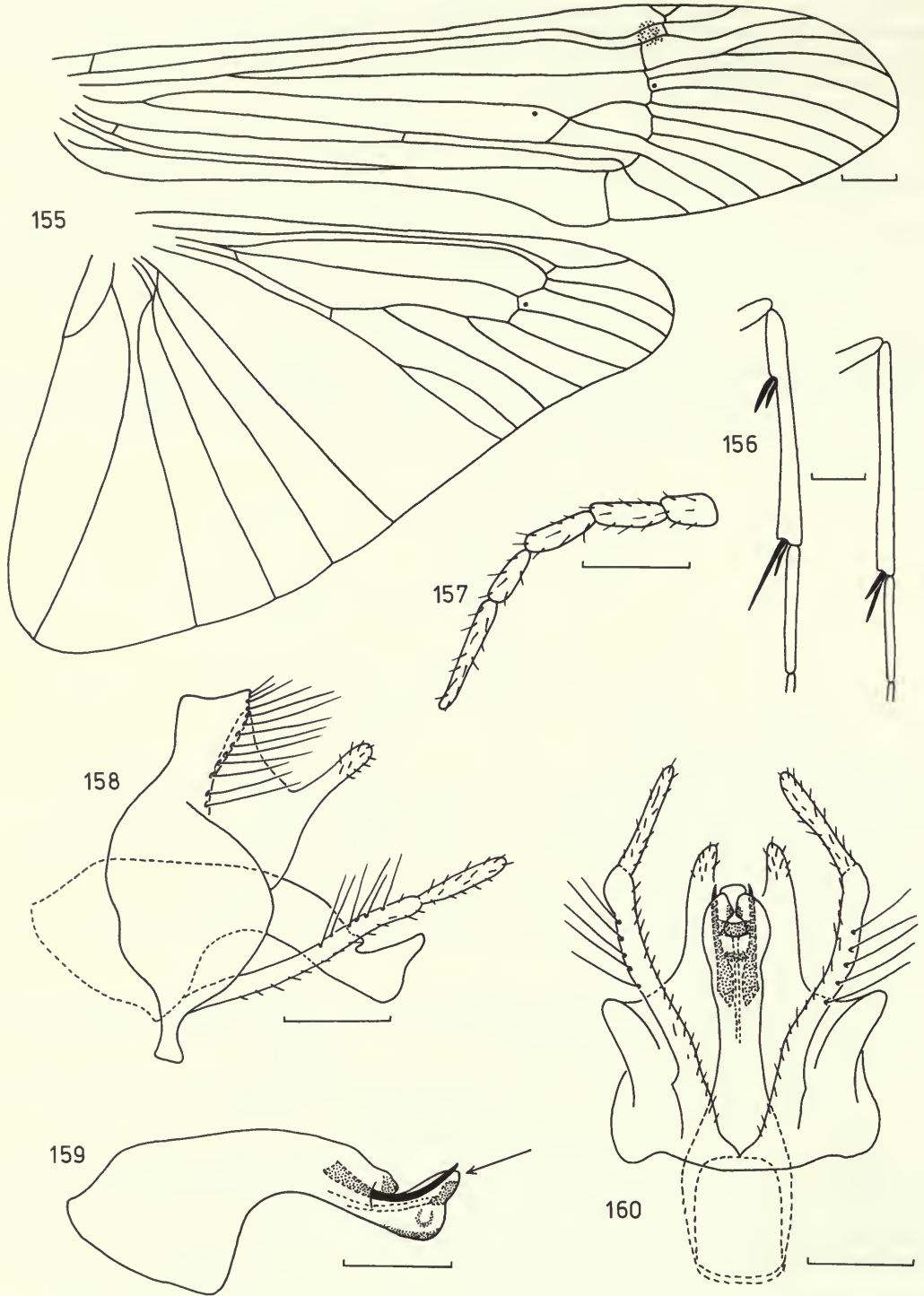

Figs 155–160 *Amphipsyche scottae* ♂. 155, wing venation; 156, mid and hind tibiae; 157, maxillary palp; 158, genitalia, lateral view; 159, phallosome, lateral view; 160, genitalia, ventral view.

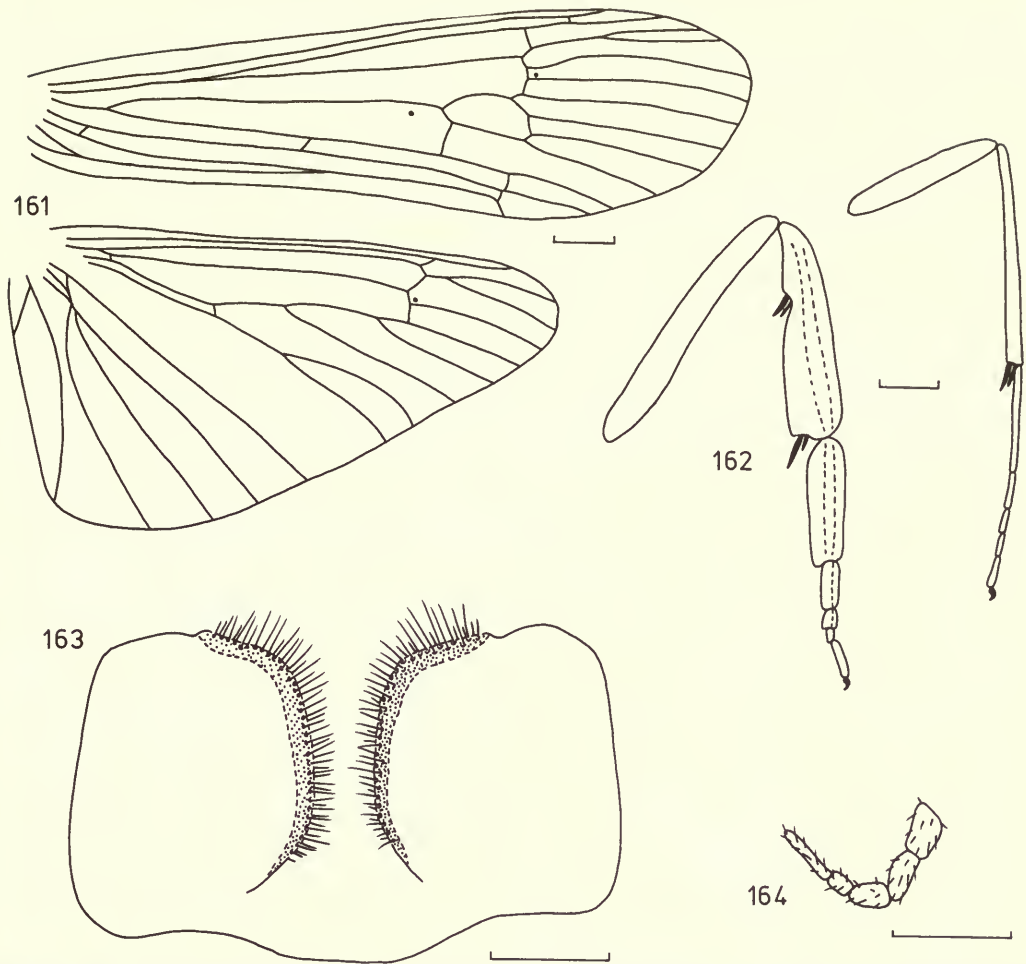

Figs 161–164 *Amphipsyche scottae* ♀. 161, wing venation; 162, mid and hind legs; 163, eighth sternites; 164, maxillary palp.

***Amphipsyche fuscata* Kimmins**

(Figs 165–170; distribution, Fig. 119)

Amphipsyche fuscata Kimmins, 1963: 128. Holotype ♂, ETHIOPIA (BMNH) [examined].

♂. Antenna up to 35 mm, with *c.* 85 segments. Fore wing 12–17 mm. Body pale yellowish brown; basal 12–15 segments of antenna yellowish brown, remainder of flagellum fuscous. Fore wing pale yellow, with fuscous streak running obliquely from costal margin proximal to anastomosis; hind margin fuscous (these markings may be very faint). Venation as in Fig. 165. Spurs 0.4.2 (Fig. 166). Maxillary palp fuscous (these markings may be very faint). Venation as in Fig. 165. Spurs 0.4.2 (Fig. 166). Maxillary palp short, 4th and 5th segments imperfectly separated, 5th segment narrow apically, not secondarily annulated (Fig. 167).

♀. Unknown.

GENITALIA ♂ (Figs 168–170). Lateral lobe of ninth segment somewhat squarish. Base of phallosome narrow and rounded, apex elongate, produced into a bifid lobe. Mid endothelial spines long, curved upwards.

REMARKS. Well-marked specimens of this species can be recognized by the oblique wing-marking, but identification of specimens with faint markings depends on the male genitalia, and here the close similarity with several other African species is apparent. However, *fuscata* differs

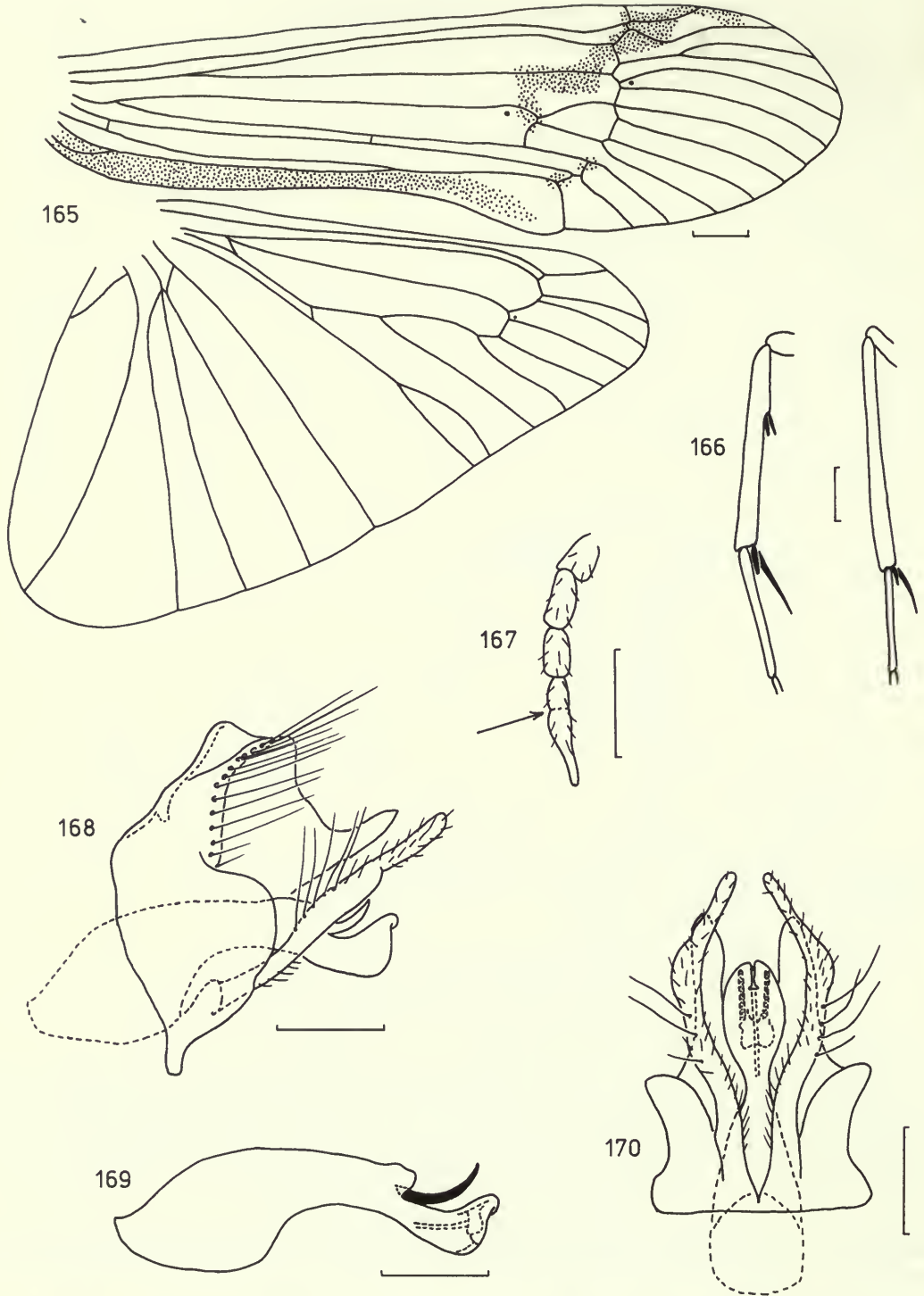

Figs 165–170 *Amphipsyche fuscata* ♂. 165, wing venation; 166, mid and hind tibiae; 167, maxillary palp; 168, genitalia, lateral view; 169, phallosome, lateral view; 170, genitalia, ventral view.

from *scottae* and *ulmeri* in having the apex of the phallosheca rounded, not pointed, and from *berneri* and *corbeti* in having a narrow base to the phallosheca. *A. fuscata* is further distinguished by the unique maxillary palps, with the 4th and 5th segments only partly fused. Kimmins (1963) noted the colour of the palps, but did not notice their unusual form.

MATERIAL EXAMINED

Holotype ♂, **Ethiopia**: Koka Dam, 29.iii.1964 (*Tjønneland*) (slide preparation, BMNH).
62 ♂, **Ethiopia** (60 ♂ paratypes), **Sudan** (BMNH).

Amphipsyche corbeti Kimmins

(Figs 171–176; distribution, Fig. 119)

Amphipsyche corbeti Kimmins, 1962: 89. Holotype ♂, UGANDA (BMNH) [examined].

♂. Antenna up to 30 mm, with c. 85 segments. Fore wing 11–12 mm. Body pale yellowish brown, thorax pale brown dorsally, antenna pale greyish brown. Fore wing pale yellowish brown, usually with pale brown shading around R_1 – R_s cross-vein. Venation as in Fig. 171. Spurs 0.4.2 (Fig. 172). Maxillary palp 4-segmented, terminal segment narrow and slightly elongate, but not secondarily annulated (Fig. 173).

♀. Unknown.

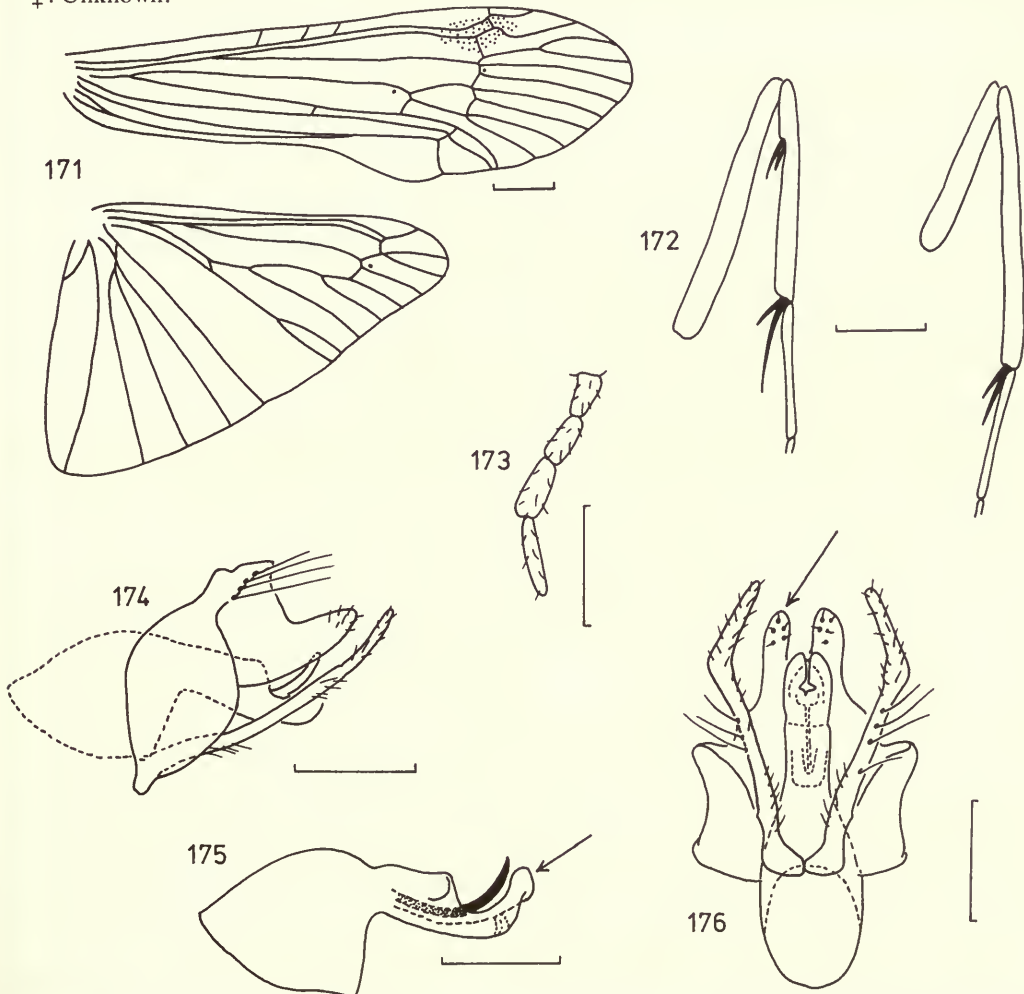

Figs 171–176 *Amphipsyche corbeti* ♂. 171, wing venation; 172, mid and hind tibiae; 173, maxillary palp; 174, genitalia, lateral view; 175, phallosheca, lateral view; 176, genitalia, ventral view.

GENITALIA ♂ (Figs 174–176). Base of phallosome broadly triangular, stem thickened, apex forming pair of lobes ventrally; mid endothelial spines long, curved dorsally. Inferior appendage slender, terminal segment scarcely differentiated.

REMARKS. This species closely resembles *berneri* and, to a lesser extent, *ulmeri*. It differs from *ulmeri* in the thicker stem of the phallosome and the longer endothelial spines, and from *berneri* in the lobes of the tenth segment. These lobes are narrower in dorsal view in *corbeti*, and do not diverge. There are also slight differences in the apex of the phallosome, best seen in ventral view.

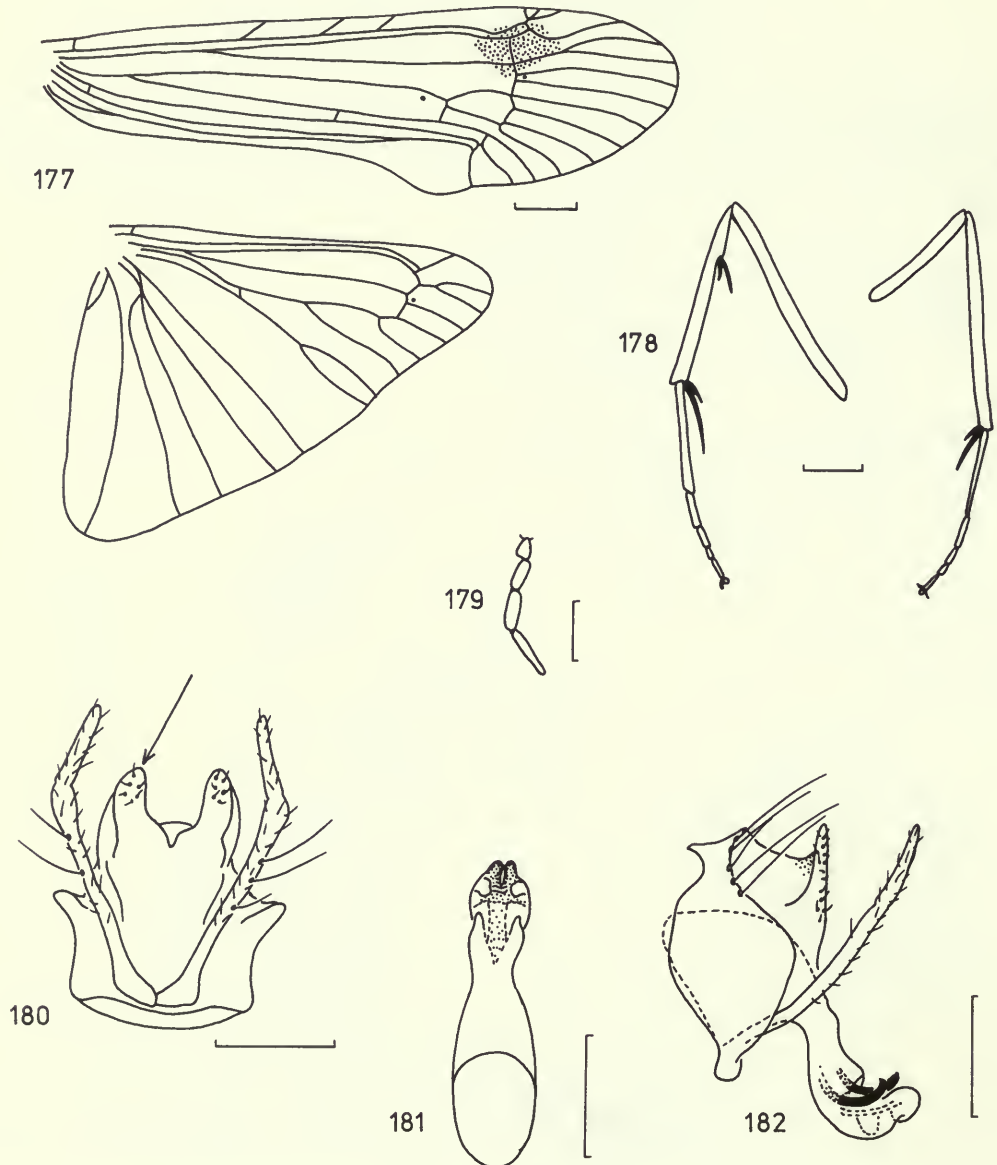

Figs 177–182 *Amphipsyche berneris* ♂. 177, wing venation; 178, mid and hind legs; 179, maxillary palp; 180, genitalia, ventral view; 181, phallosome, ventral view; 182, genitalia, lateral view.

MATERIAL EXAMINED

Holotype ♂, **Uganda**: Northern Province, Victoria Nile, Karuma Falls [no date] (*Corbet*) (slide preparation, BMNH).

33 ♂ paratypes, **Uganda** (BMNH).

Amphipsyche berneri Kimmins

(Figs 177–182; distribution, Fig. 119)

[*Phanostoma senegalense* Brauer; Kimmins, 1957a: 13 (*partim* – specimens from Gold Coast [Ghana] only). Misidentification.]

Amphipsyche berneri Kimmins, 1962: 91. Holotype ♂, GHANA (BMNH) [examined].

♂. Antenna c. 25 mm, with c. 85 segments. Fore wing 11–12 mm. Body coloration uncertain (both specimens originally preserved in alcohol). Fore wing yellowish brown, with darker marking centred on R_1 – R_s cross-vein; venation as in Fig. 177. Spurs 0.4.2 (Fig. 178). Maxillary palp 4-segmented, terminal segment scarcely longer than 3rd (Fig. 179), not secondarily annulated.

♀. Unknown.

GENITALIA ♂ (Figs. 180–182). Base of phallosome broadly triangular; ventral apex forming pair of lobes; mid endothelial spines long and curved dorsally. Inferior appendage slender, terminal segment not clearly differentiated.

REMARKS. This species is very similar to *corbeti*, both externally and in the form of the genitalia. It can be distinguished by slight differences in the shape of the apex of the phallosome and by the lobes of the tenth segment. These are broader and more divergent in dorsal view in *berneri*, although it should be noted that in the paratype (figured here) the lobes are less divergent than in the holotype figured by Kimmins (1962: 91, fig. 26). The holotype is now mounted laterally as a permanent slide preparation.

Kimmins did not comment on the 4-segmented maxillary palps, although these are clearly visible in his slide preparation of the holotype.

MATERIAL EXAMINED

Holotype ♂, **Ghana**: Volta R., Senchi, 1.viii.1950 (*Berner*) (slide preparation, BMNH).

1 ♂ paratype, **Ghana** (BMNH).

References

- Banks, N.** 1913. Synopses and descriptions of exotic Neuroptera. *Transactions of the American Entomological Society* **39**: 201–242.
- 1920. New neuropteroid insects. *Bulletin of the Museum of Comparative Zoology, Harvard* **64**: 299–362.
- 1931. Some neuropteroid insects from the Malay peninsula. *Journal of the Federated Malay States Museums* **16**: 377–409.
- 1939. Notes and descriptions of Oriental Oestropsychinae (Trichoptera). *Psyche, Cambridge* **46**: 52–61.
- 1940. Report on certain groups of neuropteroid insects from Szechwan, China. *Proceedings of the United States National Museum* **88**: 173–220.
- Barnard, P. C.** 1980. A revision of the Old World Polymorphanisini (Trichoptera: Hydropsychidae). *Bulletin of the British Museum (Natural History) (Entomology)* **41**: 59–106.
- Beatty, J.** 1982. Classes and cladists. *Systematic Zoology* **31**: 25–34.
- Betten, C.** 1909. Notes on the Trichoptera in the collection of the Indian Museum. *Records of the Indian Museum* **3**: 233–242, 5 pls.
- Boon, P. J.** 1979. Adaptive strategies of *Amphipsyche* larvae (Trichoptera: Hydropsychidae) downstream of a tropical impoundment. In Ward, J. V. & Stanford, J. A. (Eds), *The ecology of regulated streams*, pp. 237–255. New York.
- Brauer, F.** 1875. Beschreibung neuer und ungenügend bekannter Phryganiden und Oestriden. *Verhandlungen der Zoologisch-Botanischen Gesellschaft in Wien* **25**: 69–78.
- Chutter, F. M.** 1963. Hydrobiological studies on the Vaal River in the Vereeniging area. Part I.

- Introduction, water chemistry and biological studies on the fauna of habitats other than muddy bottom sediments. *Hydrobiologia* **21**: 1–89.
- 1968. On the ecology of the fauna of stones in the current in a South African river supporting a very large *Simulium* (Diptera) population. *Journal of Applied Ecology* **5**: 531–561.
- Corbet, P. S.** 1958a. Some effects of DDT on the fauna of the Victoria Nile. *Revue de Zoologie et de Botanique Africaines* **57**: 73–95.
- 1958b. Larvae of certain East African Trichoptera. *Revue de Zoologie et de Botanique Africaines* **58**: 203–213.
- 1966. Parthenogenesis in caddisflies (Trichoptera). *Canadian Journal of Zoology* **44**: 981–982.
- Corbet, P. S. & Tjønneland, A.** 1955. The flight activity of East African Trichoptera. *Universitet i Bergen Arbok* **1955**: 1–49.
- Flint, O. S. & Bueno Soria, J.** 1982. Studies of neotropical caddisflies, XXXII: the immature stages of *Macronema variipenne* Flint & Bueno, with the division of *Macronema* by the resurrection of *Macrostemum* (Trichoptera: Hydropsychidae). *Proceedings of the Biological Society of Washington* **95**: 358–370.
- Flint, O. S. & Wallace, J. B.** 1980. Studies of neotropical caddisflies XXV: the immature stages of *Blepharopus diaphanus* and *Leptonema columbianum* (Trichoptera: Hydropsychidae). *Proceedings of the Biological Society of Washington* **93**: 178–193.
- Gibbs, D. G.** 1973. The Trichoptera of Ghana. *Deutsche Entomologische Zeitschrift* (N.F.) **20**: 363–424.
- Gourou, P.** 1970. *L'Afrique*. 88 pp. Paris.
- Hafiz, H. A.** 1937. Notes on the larva and pupa of *Amphipsyche indica* Martynov (Insecta: Trichoptera). *Records of the Indian Museum* **39**: 113–116.
- Hennig, W.** 1966. *Phylogenetic systematics*. 263 pp. Urbana.
- Hickin, N. E.** 1955. Larvae of some East African Trichoptera. *Proceedings of the Royal Entomological Society of London* (A) **30**: 155–163.
- Hwang Chi-ling** 1957. Descriptions of Chinese caddis flies (Trichoptera). [In Chinese, with brief English summary.] *Acta Entomologica Sinica* **7**: 373–404.
- Jacquemart, S.** 1957. Trichoptera des Lacs Kivu et Édouard. *Exploration Hydrobiologique des Lacs Kivu, Édouard et Albert (1952–1954), Résultats Scientifiques* **3** (2): 67–129, 2 pls.
- 1963. Trichoptera. *South African Animal Life* **11**: 337–415.
- Kimmins, D. E.** 1955. Results of the Oxford University expedition to Sarawak, 1932. Order Trichoptera. *Sarawak Museum Journal* **6**: 374–442.
- 1957a. New and little-known species of African Trichoptera. *Bulletin of the British Museum (Natural History)* (Entomology) **6**: 1–37.
- 1957b. Lectotypes of Trichoptera from the McLachlan collection now in the British Museum (Natural History). *Bulletin of the British Museum (Natural History)* (Entomology) **6**: 91–126.
- 1962. New African caddis-flies (Order Trichoptera). *Bulletin of the British Museum (Natural History)* (Entomology) **12**: 81–121.
- 1963. On the Trichoptera of Ethiopia. *Bulletin of the British Museum (Natural History)* (Entomology) **13**: 117–170.
- Lepneva, S. G.** 1947. The larvae of caddisflies of the subfamily Macronematinae (Trichoptera, Hydropsychidae) in the U.S.S.R. [In Russian.] *Entomologicheskoe Obozrenie* **29**: 139–151.
- 1970. Trichoptera. II (1). Larvae and pupae of Annulipalpia. *Fauna SSSR* **88**: iv+638 pp.
- Marlier, G.** 1962. Genera des Trichoptères de l'Afrique. *Annales du Musée Royal de l'Afrique Centrale* (Série 8°, Sciences Zoologiques) **109**: 1–263.
- 1978. Sur une collection de Trichoptères de l'Afrique occidentale. *Revue de Zoologie Africaine* **92**: 283–302.
- Martynov, A. V.** 1935. On a collection of Trichoptera from the Indian Museum. Part I. Annulipalpia. *Records of the Indian Museum* **37**: 93–209.
- 1936. On a collection of Trichoptera from the Indian Museum. Part II. Integripalpia. *Records of the Indian Museum* **38**: 239–306.
- McLachlan, R.** 1872. Non-odonates (pp. 47–71). In Sélys-Longchamps, M. E. & McLachlan, R., *Matériaux pour une faune névroptérologique de l'Asie septentrionale*. Seconde partie. *Annales de la Société Entomologique de Belgique* **15**: 25–77.
- 1878. *A monographic revision and synopsis of the Trichoptera of the European fauna*. Part VII, pp. 349–428. London.
- Mosely, M. E.** 1942. Chinese Trichoptera: a collection made by Mr. M. S. Yang in Foochow. *Transactions of the Royal Entomological Society of London* **92**: 343–362.

- Navás, L. 1914. Les insectes de l'Orient recueillis par M. le baron J. de Guerne. *Entomologicheskoe Obozrenie* **14**: 319–322.
- 1922. Insectos exóticos. *Broteria* (Série Zoologia) **20**: 49–63.
- 1923. Insecta nova. *Memorie dell'Accademia Pontifica dei Nuovi Lincei* (2) **6**: 19–27.
- 1927. Névroptères d'Égypte et de Palestine. *Bulletin. Société Entomologique d'Égypte* **19** (1926): 192–216.
- 1931a. Névroptères et insectes voisins – Chine et pays environnants. Deuxième série (1). *Notes d'Entomologie Chinoise* **1** (7): 1–10.
- 1931b. Insectos de la India. *Revista de la Academia de Ciencias Exactas, Físico-Químicas y Naturales de Zaragoza* **14** (1930): 74–92.
- 1934. Insecta orientalia XIII. *Memorie dell'Accademia Pontifica dei Nuovi Lincei* (3) **1**: 217–228.
- 1935. Décados de insectos nuevos. 27. *Broteria* (Série trimestral) **4** (31): 97–107.
- Nelson, G. & Platnick, N. I. 1981. *Systematics and biogeography: cladistics and vicariance*. xiii+567 pp. New York.
- Nielsen, A. 1957. A comparative study of the genital segments and their appendages in male Trichoptera. *Biologiske Skrifter, Danske Videnskabernes Selskab* **8** (5): 1–159.
- Platnick, N. I. 1979. Philosophy and the transformation of cladistics. *Systematic Zoology* **28**: 537–546.
- Resh, V. H. & Unzicker, J. D. 1975. Water quality monitoring and aquatic organisms: the importance of species identification. *Journal of the Water Pollution Control Federation* **47**: 9–16.
- Savigny, M. J. C. L. de 1813. *Description de l'Égypte*. Histoire Naturelle, vol. 2 (Névroptères, pl. 3, fig. 18). Paris.
- Schmid, F. 1958. Trichoptères de Ceylan. *Archiv für Hydrobiologie* **54**: 1–173.
- 1980. Genera des Trichoptères du Canada et des États adjacents. *Les Insectes et Arachnides du Canada* **7**: 1–296.
- Scott, K. M. F. 1970. Some notes on the Trichoptera of standing waters in Africa, mainly south of the Zambezi. *Hydrobiologia* **35**: 177–195.
- 1975. The value of larval stages in systematic studies of the Trichoptera, with particular reference to the Hydropsychidae from Africa south of the Sahara. *Proceedings of the 1st Congress of the Entomological Society of South Africa* **1975**: 41–52.
- (in press). On the Hydropsychidae (Trichoptera) of southern Africa with keys to African genera of imagos, larvae and pupae and species lists. *Annals of the Cape Provincial Museums (Natural History)* **14** (8).
- Seshadri, A. R. 1955. An extraordinary outbreak of 'caddice flies' (Trichoptera) in the Mettur-Dam township area in Salem District, South India. *Indian Journal of Entomology* **17**: 337–340.
- Smith, A. G., Hurley, A. M. & Briden, J. C. 1981. *Phanerozoic palaeocontinental world maps*. vi+102 pp. Cambridge.
- Stanford, J. A. & Ward, J. V. 1981. Preliminary interpretations of the distribution of Hydropsychidae in a regulated river. *Proceedings of the 3rd International Symposium on Trichoptera, 1980*, pp. 323–328.
- Statzner, B. 1981. A progress report on Hydropsychidae from the Ivory Coast: characters for the specific identification of larvae and population dynamics of four abundant species. *Proceedings of the 3rd International Symposium on Trichoptera, 1980*, pp. 329–335.
- Ulmer, G. 1907. Trichopteren. Monographie der Macronematinae. *Collections Zoologiques du Baron Edm. de Selys Longchamps* **6** (2): 1–121. Brussels.
- 1909. Einige neue exotische Trichopteren. *Notes from the Leyden Museum* **31**: 125–142.
- 1910. Über einige von Herrn E. Jacobson auf Java gesammelte Trichopteren. *Notes from the Leyden Museum* **32**: 47–66.
- 1913. Über einige von Edw. Jacobson auf Java gesammelte Trichopteren. *Notes from the Leyden Museum* **35**: 78–101.
- 1923. Trichopteren aus dem ägyptischen Sudan und aus Kamerun. *Mitteilungen der Münchener Entomologischen Gesellschaft* **13**: 9–20.
- 1924. Wissenschaftliche Ergebnisse der mit Unterstützung der Akademie der Wissenschaften in Wien aus der Erbschaft Treitl von F. Werner unternommenen zoologischen Expedition nach dem Anglo-Ägyptischen Sudan (Kordofan) 1914. XII. Trichopteren und Ephemeropteren. *Denkschriften der Akademie der Wissenschaften, Wien* **99**: 1–9.
- 1927. Einige neue Trichopteren aus Asien. *Entomologische Mitteilungen* **16**: 172–182.
- 1930. Trichopteren von den Philippinen und von den Sunda-Inseln. *Treubia* **11**: 373–498.
- 1951. Köcherfliegen (Trichopteren) von den Sunda-Inseln (Teil I). *Archiv für Hydrobiologie, Supplement* **19**: 1–528.

- 1957. Köcherfliegen (Trichopteren) von den Sunda-Inseln (Teil III). *Archiv für Hydrobiologie*, Supplement 23: 109–470.
- 1963. Trichopteren (Köcherfliegen) aus Ägypten. *Archiv für Hydrobiologie* **59**: 257–271.
- Weidner, H. 1964. Die entomologischen Sammlungen des Zoologischen Staatsinstituts und Zoologischen Museums Hamburg. *Mitteilungen aus dem Hamburgischen Zoologischen Museum und Institut* **62**: 55–100.
- Wiley, E. O. 1981. *Phylogenetics: the theory and practice of phylogenetic systematics*. xvi+439 pp. New York.

Index

Synonyms are in *italics*; principal references are in **bold**. References to Table 1 (p. 82), the cladogram (p. 83) and the check-list (p. 85) are not included.

- Aethaloptera 72, 78, 84
 Amphipsyche 71, 75, **76**
Amphipsyche 76, 77, 112
 apicalis 77, 83, **94**, 96, 99
 apicalis-group 77, 78, 80, 81, 83, 84, **94**, 96, 99
- bengalensis 81, 105, **111**, 112
 berneri 77, 84, 125, 126, **127**
 bifasciata 89
 Blepharopus 74
- Cheumatopsyche 80
 corbeti 84, **125**, 127
curvinerve 78, 79, **112**, 113, 115, 121
- delicata 81, **93**
 distincta 83, 86, **89**, 94
- exsiliens 83, 94, **96**
 extrema 76, 81, **112**
- fuscata 84, **123**
- gratiosa 83, 96, **98**
- indica* 78, 93, **106**, 108, 110, 111
 instabilis 83, 84, 88, **117**
- Leptonema 74, 79
 Leptopsyche 75
- Macronema 72, 74, 79
 Macronematinae 72, 74
 Macronematini 72, 74
 Macrostemum 74, 75, 78, 79, 84
 magna 77, 84, 92, **102**
 meridiana 78, 79, 80, 83, 93, 99, 105, **106**, 111, 112
 meridiana-group 77, 78, 80, 81, 83, 84, 85, 88, 94, **101**, 105, 112, 117
minima 94, **99**
- nirvana* **106**, 108, 109
- paraproluta* **86**, 88
 parva 104, **105**
 pellucida 84, **115**
 petiolata 94, 96, **99**
Phanostoma **76**, 77, 79, 108
plicata **117**, 119, 120
- Polymorphanisini 72, 74
 Polymorphanisus 84
 proluta 76, 78, 83, **86**, 89, 99, 106, 119
 proluta-group 77, 78, 80, 81, 83, 84, **86**, 88, 94
propinqua **106**, 108, 110
 Protomacronema 74, 75, 77, 79, 84
 Pseudoleptonema 74
pubescens **99**, 100
- scottae* 72, 79, 80, **121**, 125
 senegalensis 76, 78, 79, 80, 83, 84, **112**, 119, 121
sigmosa **107**, 110
 Simulium 71, 72, 79
 sinhala 81, **105**, 108, 111, 112
- tricalcarata* **107**, 110
 Trichomacronema 74
- ulmeri 78, 84, 113, **120**, 121, 125, 126
- vedana* 106

British Museum (Natural History)

Blue Butterflies of the *Lycaenopsis*-group

J. N. Eliot and A. Kawazoé

The most wide-spread member of the *Lycaenopsis*-group is known and loved in Britain as the Holly Blue, in North America as the Spring Azure and in Japan as Ruri Shijimi (the Small Lapis Lazuli). In appearance and behaviour it is typical of the group, which attains its maximum diversity and abundance in the mountains of South East Asia and New Guinea. Hitherto the systematics of the group have been in a state of confusion. In this work 112 species are recognised divided among 21 genera. These are defined mainly on characters of the genitalia, which are figured for the males of each, and the females of most, species. There are keys to, and descriptions of, the genera, subgenera, species and subspecies, including 8 new genera and 27 new species. The new species and those not previously figured are illustrated in the plates at the rear of the book, and references are given to published figures of the remaining species. Finally, there is a complete bibliography, enabling the original descriptions of all the taxa to be traced.

John Eliot is the author of many papers of a taxonomic nature and was the reviser of the third edition of Corbet & Pendlebury's classic work "The Butterflies of the Malay Peninsula" first published half a century ago. His contribution to zoology has been recognised by the presentation of the Stamford Raffles Award of the Zoological Society of London and the J. H. Bloomer Award of the Linnean Society of London.

Akito Kawazoé has published many taxonomic papers, mainly in Japanese journals, and is best known in Europe as the senior author of "Coloured Illustrations of the Butterflies of Japan", a work notable not only for its superb coloured plates but also for numerous black and white drawings illustrating structural characters. His skill as artist and microscopist is again demonstrated in this book by more than two hundred figures of genitalia which will prove indispensable to a proper understanding of the *Lycaenopsis*-group.

Blue butterflies of the *Lycaenopsis*-group. J. N. Eliot & A. Kawazoé
1983, 296pp, 18 plates include 6 in colour, 560 text figures. (0 565 00860 9)
£28.00

Titles to be published in Volume 48

Gelechiid moths of the genus *Mirificarma*.

By Linda M. Pitkin.

Macronematine caddisflies of the genus *Amphipsyche* (Trichoptera: Hydropsychidae)

By P. C. Barnard.

A review of the genera of Indo-Pacific Encyrtidae (Hymenoptera: Chalcidoidea).

By John S. Noyes and M. Hayat

BRITISH MUSEUM
INSTITUTION
29 JUN 1984
GEOL

Bulletin of the British Museum (Natural History)

A review of the genera
of Indo-Pacific Encyrtidae
(Hymenoptera: Chalcidoidea)

John S. Noyes & M. Hayat

Entomology series
Vol 48 No 3

28 June 1984

The *Bulletin of the British Museum (Natural History)*, instituted in 1949, is issued in four scientific series, Botany, Entomology, Geology (incorporating Mineralogy) and Zoology, and an Historical series.

Papers in the *Bulletin* are primarily the results of research carried out on the unique and ever-growing collections of the Museum, both by the scientific staff of the Museum and by specialists from elsewhere who make use of the Museum's resources. Many of the papers are works of reference that will remain indispensable for years to come.

Parts are published at irregular intervals as they become ready, each is complete in itself, available separately, and individually priced. Volumes contain about 300 pages and several volumes may appear within a calendar year. Subscriptions may be placed for one or more of the series on either an Annual or Per Volume basis. Prices vary according to the contents of the individual parts. Orders and enquiries should be sent to:



Publications Sales,
British Museum (Natural History),
Cromwell Road,
London SW7 5BD,
England.

World List abbreviation: *Bull. Br. Mus. nat. Hist.* (Ent.)

© Trustees of the British Museum (Natural History), 1984

The Entomology series is produced under the general editorship of the
Keeper of Entomology: Laurence A. Mound
Assistant Editor: W. Gerald Tremewan

ISBN 0 565 06002 3
ISSN 0524-6431

British Museum (Natural History)
Cromwell Road
London SW7 5BD

Entomology series
Vol 48 No 3 pp 131-395

Issued 28 June 1984

work is required. Conversely, where we agree it should give workers a greater degree of confidence in any proposed taxonomic changes. There will thus also be a measure of duplication between our two works, but hopefully this has been kept to a minimum.

Contributions to knowledge of the fauna of other areas of the Indo-Pacific region have included papers by several authors, e.g. Ashmead (1905*a,b*), Girault (1919*a,b*; 1920*c*), Gahan (1927*b*), Ferrière (1931), Eady (1960*a,b*), Kerrich (1963; 1967; 1978) also Subba Rao (1970; 1973; 1978) and Trjapitzin (1965) on the fauna of South East Asia, whilst Perkins (1910), Swezey (1946), Fullaway (1946), Timberlake (1920; 1924; 1941) and Beardsley (1969; 1976) contributed papers on the fauna of the Hawaiian Islands and other Pacific islands.

The present study recognises 263 described genera and 977 described species of Encyrtidae as occurring in the Indo-Pacific region. The types, or reliably determined specimens of virtually all of the described species known from the area, have been examined by either one or both of us. This includes examination (by JSN) of nearly all of the types of the species described by Girault from South East Asia and Australia. We have also examined a great deal of unidentified material collected from all over the region.

The relationship between faunas of the various component areas of the Indo-Pacific region and other zoogeographical areas in terms of distribution of the genera is summarised in Tables 1 and 2. Here the relationship between these areas is indicated by the number of genera with distributions which are restricted to a particular type. For example, five genera are distributed from the Indian subcontinent to Australasia excluding Australia (Table 1; line 3 column 4, or, line 4 column 3), but nine from the Indian subcontinent to Australia (Table 1; line 2, column 4, or, line 4, column 2); similarly six genera are distributed from Australasia (excluding Australia) to Africa and Europe (Table 2; line 3, column 3), but four are restricted to India and the Palearctic and Afrotropical regions (Table 2, line 7, column 4). As might be expected, the Australian fauna has a strong relationship with that of the Oriental region, there being at least 11 genera known only from Australia, through India to the Afrotropical region and at least a further 30 genera found in South East Asia and Australia only. Sixteen genera have been found only in India and 60 only in Australia, but this probably reflects the activities of collectors rather than actual distribution. It is apparent that the relationship between the Australian and Neotropical faunas is not as strong as suggested previously (Noyes, 1980), although there are some genera known only from the Australasian and Neotropical regions, e.g. *Austroencyrtus*, and from the Oriental, Australasian and Neotropical regions, e.g. *Meniscocephalus*.

Table 1 The relationships between the encyrtid faunas of the component areas of the Indo-Pacific region (given in numbers of genera).

Geographical region	Pacific	Australia	Australasia (excluding Australia)	Indian subcontinent
Continuous distribution to Pacific only	5	1	1	4
Continuous distribution to Australia only	1	60	10	9
Continuous distribution to Australasia only (excluding Australia)	1	10	16	5
Continuous distribution to the Indian subcontinent	4	9	5	16

Keys to genera found in other zoogeographical regions have been published by Trjapitzin (1971*a*) for the Palearctic region, Trjapitzin & Gordh (1978*a,b*) for the Nearctic region, Prinsloo & Annecke (1979) for the Afrotropical region, and Noyes (1980) for the Neotropical region.

Table 2 The relationships between the encyrtid faunas of the component areas of the Indo-Pacific region (given in numbers of genera) and other zoogeographical areas.

Geographical region	Pacific	Australia	Australasia (excluding Australia)	Oriental
Continuous distribution to Europe and Africa	—	11	—	—
Continuous distribution to Europe excluding Africa	—	1	1	3
Continuous distribution to Africa excluding Europe	2	11	6	7
Stated region plus Palaearctic only	—	3	—	—
Stated region plus Neotropics only	—	1	5	—
Stated region plus New World only	—	—	—	6
Stated region, Palaearctic, and Africa only	—	—	—	4

Cosmopolitan genera 50, introduced or probably introduced genera 10, other distribution patterns 15

Notes on generic review

Classification

Currently there are two basic systems of classification of the Encyrtidae in use. Most previous authors (Erdős & Novicky, 1955; Hoffer, 1955; Compere & Annecke, 1960; Tachikawa, 1963; Kerrich, 1967) have divided the family into three subfamilies: Arrhenophaginae, Antheminae and Encyrtinae, the last mentioned containing almost all known genera. In the present work we follow Trjapitzin (1973*a,b*) who recognises only two subfamilies, the Tetracneminae and the Encyrtinae, which can be separated as follows.

Tetracneminae. Paratergites present or at least represented by a membranous strip which connects the outer plates of the ovipositor to the sides of the last gastral tergite, either along its length or at the base near the cercal plates only. Linea calva of forewing with undifferentiated margins and filum spinosum almost always absent. Hypopygium triangular and always reaching apex of gaster. Mandibles with all teeth apically acute (except *Doliphoceras siccus* Prinsloo & Annecke from southern Africa).

Encyrtinae. Paratergites almost always absent (present in some *Trechnites* and *Cercobelus*). Linea calva of forewing generally with setae on proximal side longer and stronger than those on distal side. Filum spinosum almost always present. Hypopygium often short and subrectangular (not reaching more than half way along gaster) but often triangular and reaching apex of gaster. Mandibles sometimes with a broadly truncate edge or tooth.

Trjapitzin divides the Tetracneminae into 12 tribes and the Encyrtinae into 36 tribes. We feel that many of these tribes are unnecessary and occasionally they are even placed by Trjapitzin in the wrong subfamily, e.g. Mirini, Neodiscodini, Rhinoencyrtini. Even so his study is the most detailed to date (although it is based mainly on the Palaearctic Fauna whilst encyrtids are a predominantly tropical group), therefore we have attempted to place, as far as possible, the Indo-Pacific genera according to his proposed classification. At the same time we have commented on several tribes and subtribes which require some modification. A new system of tribal classification is not proposed here since this is beyond the scope of the present work; the genera are arranged alphabetically, although a summary of their possible systematic positions in relation to Trjapitzin's classification is given on p. 353.

Taxonomic changes

Unless otherwise stated, the new generic and specific synonymies and the new combinations have resulted from the examination of relevant type-material. Generally, if genera are here

synonymised without comment, the relevant type-species are so close morphologically as to be difficult to separate even at specific level. This usually applies only to genera described by Girault from Australia. For new combinations, comments are limited to those species where we feel that this is necessary, since to discuss each proposed new combination would greatly and unnecessarily increase the length of the text.

Notes on key

The encyrtid genera are not easily keyed into distinct groups such as subfamilies, tribes etc., therefore the key deals with all genera together and may thus prove very daunting to the user because of its length. We have tried to overcome this by dividing the key into groups of not more than 27 couplets. Each group is entered from one of the first 44 couplets and is delimited by couplet numbers in bold type. The genera in each group are not necessarily related. Thus, to arrive at a generic name, it should not be necessary to run any specimen through more than 29 couplets and generally fewer than that.

Some of the characters used to separate groups of genera, e.g. relative widths of scape, position of apex of hypopygium, relative length of funicle segments, forewing hyaline or infusate etc., can be rather weak or ambiguous. For instance, it is not always easy to be certain whether a wing is truly hyaline or slightly infusate; however, in several such instances, a species has been keyed out to the relevant genus via both alternatives. Some of the couplets are complex. It is therefore possible for the user to make a wrong decision and go hopelessly wrong unless both alternatives of a couplet have been carefully read and understood before a decision is made to go one way or the other. The key is almost entirely artificial, therefore it must be stressed that all determinations should be confirmed by comparison of the relevant material with a reliable generic description. It must also be remembered that a specimen does not necessarily belong to an undescribed genus if it does not run easily through the key or if it runs directly to a genus to which the user knows that it cannot belong. Even if the key is used correctly it is likely that only a small majority of species will run to the correct genus. This is because it is doubtful whether the present review covers more than a very small fraction of the species which actually occur in the region and which can be placed in already recognised genera.

It is inevitable that there has to be some degree of simplification in a work with as large a coverage as this, and which deals with many poorly worked genera; this is particularly so with regard to the separation of some of the genera within taxonomically difficult groups, e.g. Anagyrini, Cheiloneurini, Habrolepidini and Microteriyini (subtribe Syrphophagina) (see comments under relevant genera). Such simplification has been necessary in order to complete the key and to avoid making it difficult to use.

Finally, the males are not keyed to genera because those of a very large number of Indo-Pacific genera are not known; also our experience has shown that most entomologists do not attempt to place unknown males to genus.

Notes on terms and measurements

Unless otherwise stated in the captions, the figures were drawn directly from slide-mounted material using a drawing tube attachment on a compound microscope, therefore relative measurements can be taken directly from these figures. However, such measurements must not be made where the points of reference for these were not equidistant from the objective of the microscope when these drawings were made, e.g. relative width of scape (since the scape is rarely absolutely flat on a slide mounted specimen), relative distance of antennal toruli from mouth margin, relative length of malar space to eye length, POL to OOL, etc. These measurements are only reliable if taken from a dry, card-mounted specimen.

Head (Figs 1–4)

Antennal clava. Composed of one to three segments. If more than one segment then these are separated by partial or complete sutures and are not as clearly separated as the funicle segments.

The apex of the clava has a sensory part which is indicated by an area of micropilosity and/or microtubules and/or a sieve-plate structure (these are individually only visible on a good slide preparation examined at high magnification). This sensory part is easily seen on dry-mounted material, is usually flattened and may either be transverse, oblique or a narrow horizontal strip. If it is large it gives the clava a truncate appearance, thus the clava may appear transversely or obliquely truncate as opposed to apically rounded. Often a slide-mounted antenna which is apically obliquely truncate will appear to be apically rounded; this may either result from the clava not being correctly orientated or the sensory part having been inflated during clearing. Therefore when using the following key it is best to determine the presence or absence of an oblique truncation using dry-mounted material.

Antennal funicle. This does not include the anellus (or false ring-joint of Timberlake, 1922b: 168, 172), which may be present or absent but is almost always hidden by the pedicel and invisible in dry-mounted material. In the Encyrtidae the anellus never bears setae, whereas the funicle segments always bear setae (although sometimes very short). The relative length of the setae to the diameter of the segments can be taken directly from the text-figures.

Eye. The measurements of length and breadth are the maximum and minimum diameters respectively; the points from which the measurements are taken should be equidistant from the objective of the microscope (i.e. both in focus simultaneously).

Frontoververtex width. The measurements are taken either at the level of the anterior ocellus or at the point where the frontoververtex is narrowest, as stated in text.

Head width. The maximum width of the head either in frontal view (as in Fig. 3) or side view (as in Fig. 4), as stated in text.

Malar space. The minimum distance between eye and mouth margin. The measurement is taken as for eye (above).

Malar sulcus. The sulcus joining the lower margin of the eye and mouth margin (see Figs 3, 4), sometimes absent but usually indicated by a slight change of sculpture.

Mandibles. The dentition can vary as follows: without teeth (Fig. 218), with one long curved tooth (Fig. 129), one tooth and a broad truncation (Figs 14, 121, 189, 229, 271), two teeth, two teeth and a truncation (Figs 75, 122, 225, 347, 381), two teeth and a rudimentary third tooth, three teeth (Figs 76, 123, 136, 144, 178, 221, 397, 435, 443) or four teeth (Figs 116, 188, 293, 294). However, this is not always clear since the distinction between two teeth and a truncation and three teeth is often not very great (see Figs 76, 123, 347). Similarly for the difference between one tooth and a truncation and two teeth and a truncation (see Figs 74, 115, 319), between three teeth and four teeth (see Fig. 188) and occasionally also between two teeth and a truncation and four teeth.

OOL. The minimum distance *between* the eye margin and the nearest posterior ocellus (see Fig. 2).

POL. The minimum distance *between* the posterior ocelli (see Fig. 2).

Thorax (Figs 5–7)

Forewing (Fig. 5).

Filum spinosum: a series of peg-like setae on distal margin of linea calva which are clearly stouter than adjacent setae.

Length of forewing: measured from most proximal part of costal cell to apex of wing.

Linea calva (or speculum of some authors): an oblique hairless line extending from just below marginal and stigmal veins to posterior margin of forewing.

Marginal vein: measured from where the submarginal vein reaches the anterior margin of wing (as shown in Fig. 5), or from where the anterior edge of the venation at the junction of the submarginal vein is abruptly angled and not from the subapical hyaline break of the submarginal vein.

Parastigma: a very slight to strong swelling of the apical one-third of the submarginal vein.

Postmarginal vein: measured as shown in Fig. 5, its apex usually indicated by a single, relatively long, suberect seta.

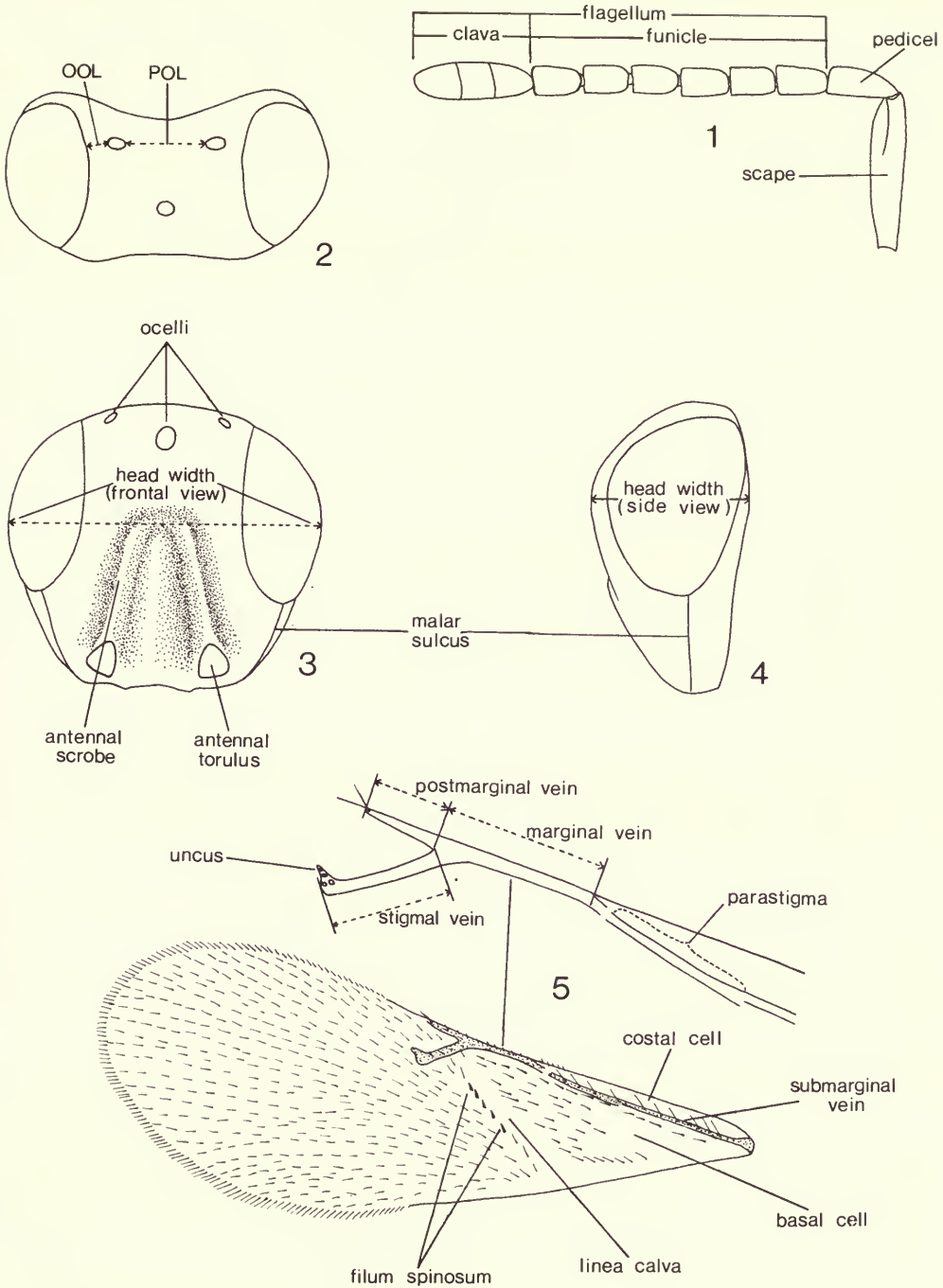

Figs 1-5 1, generalized encyrtid ♀ antenna, left, outer aspect; 2, generalized encyrtid ♀ head, dorsal aspect; 3, generalized encyrtid ♀ head, frontal aspect; 4, generalized encyrtid ♀ head, aspect from left side; 5, generalized encyrtid forewing, upper surface.

Stigmal vein (or radial vein of some authors): measured as shown in Fig. 5. There are usually four (sometimes fewer) circular sensillae at its apex. The relative position and number of these sensillae are occasionally very useful in separating generic groups.

Uncus: beak-like process often arising from apex of stigmal vein.

Notaular lines (or parapsidal lines of some authors) (Fig. 6). These are occasionally difficult to see in dry-mounted material unless viewed under correct light conditions.

Propodeum. The length is measured along the mid-line.

Scutellum. The length is measured along the mid-line; the breadth excludes the axillae.

Gaster (Fig. 8)

Cerci (or pygostyles of some authors). The relative position is measured in dry-mounted material; if it is measured in material which has been in alcohol or slide-mounted, the gaster may be distended and the cerci will be positioned relatively nearer the apex of the gaster.

Gonostylus. The third valvula, or ovipositor sheath, as seen in slide-mounted material.

Hypopygium (or subgenital plate of some authors). The relative position of the apex is measured in dry-mounted material. Care must be taken to take this measurement from specimens in which the ovipositor has not dropped down into the laying position, particularly in the Encyrtinae. Here the hypopygium is usually retracted during oviposition and thus a hypopygium which normally reaches the apex of the gaster will often appear to reach only half to two-thirds of the way along the gaster.

Last tergite (syntergum or epipygium of some authors). Its length is measured from its apex to the centre of an imaginary line connecting the cercal plates.

Ovipositor. The length of the exerted part is measured from the apex of the last gastral tergite (never hypopygium) in dry-mounted material. If material has been in alcohol the gaster may be distorted and the ovipositor may appear to be relatively more exerted; in this case it would be better to use the relative lengths of the exerted parts of the gonostyli (ovipositor sheaths).

Ovipositor sheath. The gonostylus as seen in dry-mounted material.

Abbreviations

- AMNH American Museum of Natural History, New York, USA.
 ANIC Australian National Insect Collection, Division of Entomology CSIRO, Canberra, Australia.
 BMNH British Museum (Natural History), London, UK.
 BPBM Bernice P. Bishop Museum, Honolulu, Hawaii.
 CNC Canadian National Collection, Biosystematics Research Institute, Ottawa, Canada.
 DSIR Division of Entomology, Department of Scientific and Industrial Research, Auckland, New Zealand.
 GC Gijwijt collection, c/o M. J. Giswijt, PO Box 4, 1243 ZG, 'S-Graveland, Netherlands.
 HC Hayat collection, c/o M. Hayat, Department of Zoology, Aligarh Muslim University, Aligarh, India.
 HDOU Hope Museum, Oxford University, Oxford, England.
 HNHM Hungarian Natural History Museum, Budapest, Hungary.
 IPK Institute für Pflanzenschutzforschung, Eberswalde, DDR.
 MCSN Museo Civico di Storia Naturale, Genova, Italy.
 PPRI Plant Protection Research Institute, Pretoria, South Africa.
 QM Queensland Museum, Brisbane, Australia.
 UCR University of California, Riverside, California, USA.
 USNM National Museum of Natural History, Washington DC, USA.
 RMNH Rijksmuseum van Natuurlijke Historie, Leiden, Netherlands.
 SAM South Australian Museum, Adelaide, Australia.
 ZI Zoological Institute, Academy of Sciences, Leningrad, USSR.
 ZMCU Zoological Museum, Cambridge University, Cambridge, England.

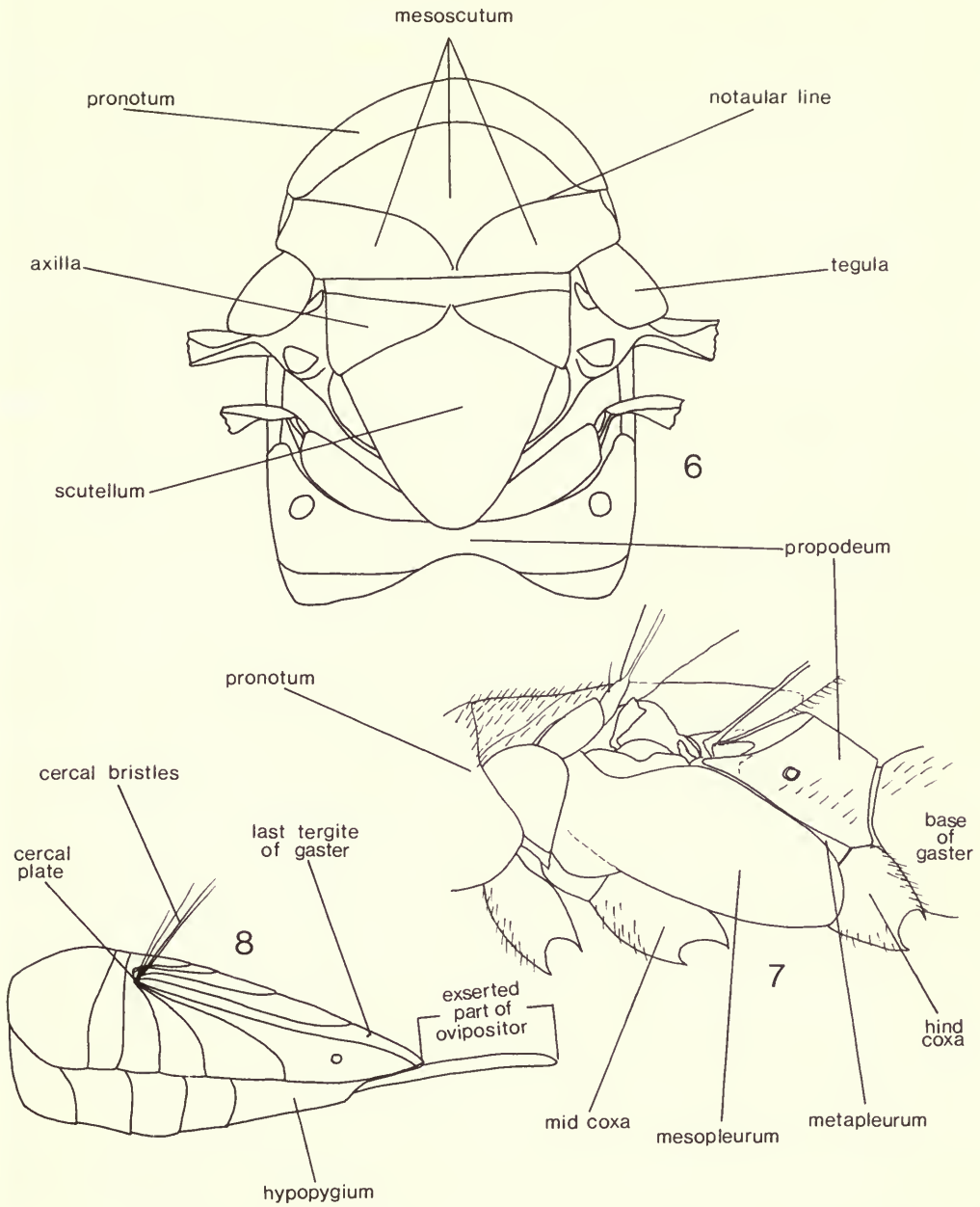

Figs 6-8 6, *Homalotylus flaminius* (Dalman) ♀, thorax, dorsal aspect; 7, *Charitopus* sp. ♀, thorax, aspect from left side; 8, generalized encyrtid ♀ gaster, aspect from left side.

Key to genera (females)

1	Tarsi four-segmented	45 (p. 143)
–	Tarsi five-segmented	2
2 (1)	Funicle with fewer than six segments	3
–	Funicle with at least six segments	4
3 (2)	Funicle three- or four-segmented	46 (p. 143)
–	Funicle five-segmented	55 (p. 143)
4 (2)	Forewing shortened, clearly not reaching apex of gaster	5
–	Forewing normal, at least very nearly reaching apex of gaster	6
5 (4)	Hypopygium reaching or very nearly reaching apex of gaster (at least four-fifths along gaster)	73 (p. 144)
–	Hypopygium not reaching more than two-thirds along gaster	85 (p. 146)
6 (4)	Scutellum either with a group of coarse, long, dark setae arranged in a more or less compact tuft or bundle (Fig. 47), or with two or more scale-like setae (Figs 44, 48)	95 (p. 148)
–	Scutellum without a distinct tuft or bundle of setae or scale-like setae	7
7 (6)	Scape not more than three times as long as broad	8
–	Scape more than three times as long as broad	15
8 (7)	Flagellum broadened and flattened, at most only first funicle segment not transverse (Figs 51–54, 56, 57, 302)	104 (p. 150)
–	Flagellum not flattened, more or less cylindrical to broadly oval in cross-section, or if appearing flattened then at least first two segments longer than broad	9
9 (8)	Forewing infusate or with a very distinct pattern of dark and pale setae and thus appearing infusate (excluding those species with a very indistinct suffusion of yellow or pale brown or with a very small spot beneath marginal vein which does not or hardly extends past apex of stigmal vein)	10
–	Forewing hyaline (including those species with a very indistinct suffusion of yellow or pale brown, or with a small spot beneath marginal vein which does not or hardly extends past apex of stigmal vein)	12
10 (9)	Clava strongly apically obliquely truncate, the truncate part clearly longer than remaining portion of ventral surface of clava (Figs 60, 62, 65, 67, 69, 239, 318); pattern of forewing not composed of well-defined stripes and fuscous fasciae	120 (p. 154)
–	Clava more or less apically rounded or transversely truncate, or if sutures of clava are oblique and clava thus appears to be obliquely truncate then either truncate part is shorter than remaining portion of ventral surface of clava or forewing has a strong pattern of well-defined stripes and fasciae	11
11 (10)	Hypopygium with apex not reaching more than two-thirds of way along gaster	134 (p. 156)
–	Hypopygium reaching apex of gaster	143 (p. 158)
12 (9)	Mesoscutum or scutellum or both at least partly yellow, orange or pale orange-brown	159 (p. 160)
–	Mesoscutum and scutellum completely dark, not yellow, orange or pale brown	13
13 (12)	Face with a pair of longitudinal membranous lines joined below anterior ocellus by a short transverse membranous line (Fig. 105) (these occasionally obscure in dry-mounted material because the head collapses inwards; best seen in slide-mounted specimens)	182 (p. 164)
–	Face without membranous lines	14
14 (13)	Hypopygium with apex not more than four-fifths along gaster, or if more then exerted part of ovipositor is more than one-third as long as gaster	183 (p. 164)
–	Hypopygium with apex more or less reaching apex of gaster; ovipositor not or hardly exerted	205 (p. 168)
15 (7)	Malar space very short, not more than one-fifth as long as eye, eye very nearly reaching base of mandible; body metallic green and often with distinct punctate sculpture although this may be relatively shallow; notaular lines absent	PARABLASTOTHRIX (p. 314)
–	Malar space longer, at least one-quarter as long as eye, or if shorter then body not metallic green, sculpture not punctate or notaular lines present and complete	16
16 (15)	All funicle segments longer than broad	17

-	Not all funicle segments longer than broad, at least one segment quadrate or transverse	27
17 (16)	Forewing infusate (excluding those species with only a pattern of dark and light setae, or with an indistinct suffusion of yellow or pale brown, or with a small spot beneath marginal vein which does not or hardly extends past apex of stigmal vein)	18
-	Forewing hyaline (including those species with only a pattern of dark and light setae, or with an indistinct suffusion of yellow or pale brown, or with a small spot beneath marginal vein which does not or hardly extends past apex of stigmal vein)	20
18 (17)	Antennal toruli situated relatively high on head and close together so that they are separated from mouth margin by at least one and one-half times the minimum distance between them (Fig. 128)	222 (p. 172)
-	Antennal toruli separated from mouth margin by much less than one and one-half times the minimum distance between them	19
19 (18)	First funicle segment longer than pedicel	225 (p. 172)
-	First funicle segment not longer than pedicel	238 (p. 176)
20 (17)	Either forewing with linea calva not interrupted on dorsal surface <i>or</i> filum spinosum present <i>or</i> antennal toruli high on head, nearly twice their own lengths from mouth margin	21
-	Forewing with linea calva interrupted or closed on dorsal surface of wing by more than one line of setae <i>and</i> filum spinosum absent <i>and</i> antennal toruli not more than their own lengths from mouth margin	23
21 (20)	Body distinctly dorso-ventrally flattened; pronotum longitudinally divided in middle (as in Fig. 38); ovipositor not or hardly exerted; mandible bidentate	266 (p. 180)
-	Either body not dorso-ventrally flattened, or ovipositor exerted and exerted part at least about half as long as gaster; mandible not bidentate; pronotum entire	22
22 (21)	Either notaular lines present or forewing with submarginal vein having a strongly swollen parastigma (Figs 148, 150, 151); hypopygium always reaching apex of gaster; paratergites usually evident	23
-	Notaular lines absent; forewing with parastigma not or hardly swollen (Figs 132, 152-154, 156-158, 238) or if conspicuously swollen then hypopygium does not reach more than half way along gaster; hypopygium sometimes reaching apex of gaster; paratergites almost always absent	24
23 (20,22)	Notaular lines present in at least anterior part of mesoscutum; linea calva of forewing not interrupted, although occasionally closed on dorsal surface of wing; parastigma clearly swollen (Figs 148, 150, 151)	262 (p. 180)
-	Notaular lines completely absent; linea calva almost always interrupted or widely closed on dorsal surface of wing; parastigma rarely swollen, usually not or hardly wider than proximal part of submarginal vein (Figs 91, 95, 159, 414)	266 (p. 180)
24 (22)	Marginal vein of forewing punctiform or absent	278 (p. 182)
-	Marginal vein of forewing longer than broad	25
25 (24)	Either exerted part of ovipositor at least one-third as long as gaster or propodeum medially more than one-fifth as long as scutellum	290 (p. 186)
-	Neither ovipositor with exerted part as long as one-third length of gaster nor propodeum medially longer than one-fifth length of scutellum	26
26 (25)	Either mesoscutum or scutellum (including axillae) at least partly orange, yellow or orange-brown	307 (p. 188)
-	Both mesoscutum and scutellum (including axillae) dark, not partly orange, yellow or orange-brown	317 (p. 190)
27 (16)	Exserted part of ovipositor (measured from apex of last tergite of gaster to apex of ovipositor) at least as long as one-third length of gaster	28
-	Ovipositor not exerted, or if exerted then exerted part not longer than one-quarter length of gaster	29
28 (27)	Hypopygium not extending more than three-quarters along gaster	344 (p. 196)
-	Hypopygium reaching or very nearly reaching apex of gaster	352 (p. 196)
29 (27)	Either mesoscutum, axillae or scutellum at least partly yellow, orange or orange-brown	30

-	Mesoscutum, axillae and scutellum completely dark, not partly yellow, orange or orange-brown	32
30 (29)	Either notaular lines present in at least anterior part of mesoscutum, or forewing infusate (excluding those species with only a pattern of dark and light setae, or with an indistinct suffusion of yellow or pale brown, or with a small spot beneath marginal vein which does not or hardly extends past apex of stigmal vein)	370 (p. 200)
-	Notaular lines completely absent; forewing hyaline (including those species with a pattern of dark and light setae only, or with an indistinct suffusion of yellow or pale brown, or with a small spot beneath marginal vein which does not or hardly extends past apex of stigmal vein)	31
31 (30)	Head completely dark, not yellow, orange or orange-brown and usually metallic	391 (p. 204)
-	Head at least partly yellow, orange or orange-brown, not metallic	400 (p. 206)
32 (29)	Submarginal vein of forewing with a subapical triangular expansion (usually indicated by a single, long, semi-erect seta) (Figs 107, 109, 207)	415 (p. 208)
-	Submarginal vein of forewing without a subapical triangular expansion	33
33 (32)	First funicle segment longer than broad	34
-	First funicle segment not longer than broad	40
34 (33)	Mesoscutum with complete notaular lines (Fig. 6) <i>HOMALOTYLUS</i> (p. 287)	
-	Mesoscutum without notaular lines	35
35 (34)	Marginal vein of forewing punctiform or absent	418 (p. 208)
-	Marginal vein of forewing longer than broad	36
36 (35)	Hind tibia foliaceously flattened and expanded, not more than two and one-half times as long as broad (Fig. 213) <i>NEOCLADIA</i> (p. 306)	
-	Hind tibia not expanded and flattened, or if slightly so then at least three times as long as broad	37
37 (36)	Linea calva completely obliterated on both dorsal and ventral surfaces of forewing by short, dense setae so that forewing is densely and evenly hairy from base to apex (Fig. 214) <i>NATHISMUSIA</i> (p. 302)	
-	Forewing with linea calva not obliterated	38
38 (37)	Forewing infusate (excluding those species with an indistinct suffusion of yellow or pale brown, or with a small spot beneath marginal vein which does not or hardly extends past apex of stigmal vein)	39
-	Forewing hyaline (including those species with an indistinct suffusion of yellow or pale brown, or with a small spot beneath marginal vein which does not or hardly extends past apex of stigmal vein)	434 (p. 212)
39 (38)	First funicle segment at least as long as pedicel	457 (p. 214)
-	First funicle segment shorter than pedicel	464 (p. 214)
40 (33)	Frontovertex with distinct piliferous punctures which give a thimble-like appearance, if punctures shallow then generally separated by not more than their own diameters	475 (p. 215)
-	Frontovertex without deep and distinct piliferous punctures, and not with appearance of surface of a thimble	41
41 (40)	Forewing infusate (excluding those species with an indistinct suffusion of yellow or pale brown, or with a small spot beneath marginal vein which does not or hardly extends past apex of stigmal vein)	481 (p. 215)
-	Forewing hyaline (including those species with an indistinct suffusion of yellow or pale brown, or with a small spot beneath marginal vein which does not or hardly extends past apex of stigmal vein)	42
42 (41)	Scutellum very convex with fine reticulate or reticulate-striate sculpture of a matt or silky appearance; all funicle segments transverse except occasionally the sixth (Figs 390, 395) <i>PARABLATTICIDA</i> (p. 314)	
-	Scutellum either not convex or without a reticulate-striate sculpture of silky appearance; if appearing slightly convex and with silky appearance then only first funicle segment is not longer than broad	43
43 (42)	Marginal vein of forewing punctiform	490 (p. 216)
-	Marginal vein of forewing longer than broad	44
44 (43)	Hypopygium more or less reaching apex of gaster	499 (p. 217)

- Hypopygium not reaching more than four-fifths along gaster 510 (p. 218)
- 45 (1) Antenna with two to four anelliform segments that are adpressed with clava, clava large, at least as long as remainder of antenna (Fig. 9); forewing broad, at most two and one-quarter times as long as broad, with marginal fringe much shorter than maximum wing width (Fig. 10); mandible with a single pointed tooth **ARRHENOPHAGUS** (p. 235)
- Antenna with five or six funicle segments that are clearly separated from clava, clava at most as long as funicle and pedicel combined (Fig. 13); forewing narrow, not less than three and one-half times as long as wide, with marginal fringe at least as long as wing width (Fig. 12); mandible with apex broadly truncate or serrate (Fig. 14) **ANTHEMUS** (p. 233)
- 46 (3) Forewing hyaline 47
- Forewing infusate 52
- 47 (46) Funicle three-segmented 48
- Funicle four-segmented 49
- 48 (47) Frontoververtex with a transverse membranous line between anterior ocellus and antennal toruli, this joined to antennal toruli, or nearly so, by longitudinal membranous lines (Fig. 16); funicle segments strongly transverse and closely adpressed together, clava solid, apically obliquely truncate and much longer than pedicel and funicle together (Fig. 15) **ARRHENOPHAGOIDEA** (p. 235)
- Frontoververtex without any membranous lines; funicle segments clearly separated and each quadrate or slightly longer than broad, clava three-segmented, not obliquely truncate and slightly shorter than pedicel and funicle together
MARXELLA (p. 295)
- 49 (47) Funicle segments all longer than broad (Fig. 17); forewing with marginal vein shorter than stigmal (Fig. 18); hypopygium reaching apex of gaster or beyond
CERCOBELUS (p. 247)
- Not all funicle segments longer than broad, usually broader than long or quadrate; forewing with marginal vein as long as or longer than stigmal; hypopygium not extending to apex of gaster 50
- 50 (49) Clava two-segmented; mandibles with three acute teeth **NASSAUIA** (p. 302)
- Clava three-segmented; mandibles with one or two teeth and a truncation or four teeth 51
- 51 (50) First funicle segment longer than broad and at least a little longer than the fourth
COCCIDIENCYRTUS (p. 253)
- First funicle segment clearly shorter than fourth and transverse **PLAGIOMERUS** (p. 325)
- 52 (46) Forewing more or less uniformly infusate, without sharply delimited rays, bands or spots; hypopygium extending to apex of gaster **BRACHYPLATYCERUS** (p. 243)
- Forewing either with infusate rays or bands, or infusate with hyaline patches 53
- 53 (52) All antennal segments flattened, clava obscurely two-segmented (Fig. 19); scutellum without any apical lamelliform setae.
Forewing as in Fig. 20 **SPANIOPTERUS** (p. 338)
- At most only scape flattened with flagellar segments cylindrical, clava three-segmented; apex of scutellum with at least one pair of lamelliform setae 54
- 54 (53) All funicle segments longer than broad **HOMALOPODA** (p. 287)
- Not all funicle segments longer than broad, at least first two segments transverse
CAENOHOMALOPODA (p. 243)
- 55 (3) Antennal flagellum flattened; forewing with an infusate band **ANARHOPUS** (p. 231)
- Flagellum more or less cylindrical, not flattened; forewing hyaline or lightly infusate, without a distinct band 56
- 56 (55) Body dorso-ventrally flattened; pronotum longitudinally divided **NEORHOPUS** (p. 307)
- Body robust, not dorso-ventrally flattened but if so then pronotum entire 57
- 57 (56) Wings shortened, not reaching apex of gaster; clava three-segmented 58
- Either wings fully developed and reaching apex of gaster, or clava entire 59
- 58 (57) Body entirely yellow **ZEALANDENCYRTUS** (p. 350)
- Body at least partly dark and metallic **TETRACNEMOIDEA** (p. 341)
- 59 (57) Forewing with area immediately below venation from proximal part of parastigma to apex of stigmal vein completely naked and continuous with the

- relatively wide linea calva which is conspicuously broader than length of marginal vein (Fig. 22); mandible bidentate.
- ♂ antenna branched (Fig. 21) **TETRACNEMOIDEA** (p. 341)
- Forewing with area immediately below distal one-third of venation with several setae and not naked, linea calva not or hardly broader than length of marginal vein; mandible with three teeth or one or two teeth and a truncation 60
- 60 (59) Head or thorax at least partly yellow or orange 61
- Head and thorax dark, often shiny and metallic 67
- 61 (60) Clava solid (Fig. 23) 62
- Clava two- or three-segmented 63
- 62 (61) Body dorso-ventrally flattened; head prognathous; pronotum more than half as long as mesoscutum (Fig. 24) **INDAPHYCUS** (p. 289)
- Body not dorso-ventrally flattened; head hypognathous; pronotum much shorter than one-third length of mesoscutum **ACEROPHAGUS** (p. 220)
- 63 (61) Clava two-segmented (Fig. 28) **PSEUDECTROMA** (p. 329)
- Clava three-segmented 64
- 64 (63) Notaular lines present in anterior one-third of mesoscutum; ovipositor not exerted; hypopygium not quite reaching apex of gaster **BEETHOVENA** (p. 241)
- Notaular lines absent; exerted part of ovipositor at least as long as one-fifth length of gaster; hypopygium reaching apex of gaster 65
- 65 (64) Head and thorax clothed with conspicuous dark setae; scape not longer than minimum width of frontoververtex; antennal toruli separated from mouth margin by about their own lengths; forewing with postmarginal vein about as long as stigmal; mandible with two teeth and a truncation **MOZARTELLA** (p. 300)
- Head and thorax clothed with pale or silvery white setae, or if setae dark then scape is longer than minimum width of frontoververtex, antennal toruli are nearly at mouth margin being separated from it by much less than their own lengths (Fig. 25) and forewing with postmarginal vein clearly shorter than stigmal; mandible with three acute teeth 66
- 66 (65) Antenna unicolorous, yellow or orange **ACEROPHAGUS** (p. 220)
- Clava at least partly white contrasting with brown or yellowish brown segments of funicle (Fig. 26)
- Forewing as in Fig. 27 **PSEUDAPHYCUS** (p. 328)
- 67 (60) Forewing with postmarginal vein at least about twice as long as stigmal
- HOLCOTHORAX** (p. 287)
- Forewing with postmarginal vein not or hardly longer than stigmal 68
- 68 (67) Clava transversely or obliquely truncate; notaular lines completely absent; forewing with sensillae at apex of stigmal vein arranged symmetrically in a square 69
- Either clava apically rounded or notaular lines present; forewing with sensillae at apex of stigmal vein arranged asymmetrically, not in a square 70
- 69 (68) Clava entire with apex strongly obliquely truncate, (Fig. 29)
- Base of forewing as in Fig. 30 **COPIDOSOMOPSIS** (p. 258)
- Clava three-segmented with apex more or less transversely truncate . **RAFFAELLIA** (p. 332)
- 70 (68) Notaular lines absent; exerted part of ovipositor at least one-fifth as long as gaster 71
- Notaular lines present; ovipositor not or hardly exerted 72
- 71 (70) Mandible with three acute teeth; forewing with postmarginal vein a little shorter than stigmal **PARARHOPELLA** (p. 318)
- Mandible with one or two teeth and a truncation; forewing with post marginal vein slightly longer than stigmal **MESORHOPELLA** (p. 297)
- 72 (70) Forewing with marginal vein more or less absent, venation not quite touching anterior margin of wing, submarginal vein with parastigma not conspicuously swollen (Fig. 31); scutellum always lustrous blue or green **TRECHNITES** (p. 345)
- Forewing with venation touching anterior margin of wing and marginal vein more or less quadrate, submarginal vein with parastigma conspicuously swollen (Fig. 32); scutellum dull **COCCIDAPHYCUS** (p. 253)
- 73 (5) Propodeum medially at least one-third as long as scutellum (Fig. 33) 74



A review of the genera of Indo-Pacific Encyrtidae (Hymenoptera: Chalcidoidea)

John S. Noyes

Department of Entomology, British Museum (Natural History), Cromwell Road, London SW7 5BD

M. Hayat

Department of Zoology, Aligarh Muslim University, Aligarh, Uttar Pradesh 202 001, India

Contents

Synopsis	131
Introduction	131
Notes on generic review	134
Notes on key	135
Notes on terms and measurements	135
Abbreviations	138
Key to genera (females)	140
Notes on genera	220
Incertae sedis	352
Systematic relationships of Indo-Pacific encyrtid genera	353
Host index	355
Proposed new synonymies	357
Proposed new combinations	359
Proposed new status	365
Replacement names	365
Lectotype designations	365
Acknowledgements	366
References	366
Index	383

Synopsis

A key to females of the 263 described genera of Encyrtidae recognised from the Indo-Pacific region is provided. Notes on each genus are included and give information on known world distribution, number of described species, distribution of each genus within the area under review, a list of species known from the region, references to original descriptions, redescriptions, revisions or other useful papers, biology, and systematic placement of the genus. Lectotypes are designated for 44 species; 23 genera and 18 species are described as new; one subtribe and one subspecies are raised to tribe and species level respectively; one tribal, one subtribal, 107 generic and 41 specific synonymies, 358 combinations and three replacement names for junior specific homonyms are newly proposed.

Introduction

The importance of the Hymenoptera Parasitica in biological control programmes is unquestionable. Clausen (1978) reviews a large amount of literature dealing with the introduction of natural enemies to control weeds and pest species of arthropods. A brief scan through this review soon reveals that the majority of insect species introduced to control pests are parasitic Hymenoptera, and that the most important of these are the Chalcidoidea. Perhaps an indicator of the importance of the Chalcidoidea in the field of biological control is *Biocontrol News and*

Information (published by Commonwealth Agricultural Bureaux, Slough, England), a review of literature relevant to all forms of biological control. Of all the papers reviewed, no fewer than 16 per cent contain references to chalcids. Within the Chalcidoidea, the most important families in this context are the Aphelinidae, Encyrtidae and Trichogrammatidae, species of which are most commonly used to control lepidopterous and hemipterous pests. Of the seven major, successful biological control projects listed by Bosch *et al.* (1982) for California, three have utilised species of Encyrtidae as the controlling agent. That is not to say that species of Encyrtidae are the main controlling agent for 40 per cent of all successful biological control projects, but merely to illustrate that they are, economically, a very important group.

It is essential to be able to identify species accurately in order to convey information about useful or potentially useful species. An important step facilitating the accurate identification of species is a stable classification at the generic and possibly tribal level. Thus, the present review has three aims. Firstly, to attempt to arrange the many poorly understood Australian species and genera of Encyrtidae into some general pattern which agrees as closely as possible with Trjapitzin's (1973*a,b*) classification of the group. Secondly, to bring together all relevant taxonomic information available on the Encyrtidae of the Indo-Pacific region. Thirdly, to facilitate the identification of material collected in this region.

The Indo-Pacific region is defined here as the area south of a line drawn from the northernmost tip of Pakistan to the Hawaiian Islands (also north to Midway Island). This therefore excludes Japan and Korea, but includes southern China, the Pacific islands, Australia and New Zealand. Keys to the genera of the region have been published previously by Girault (1915*a*) for Australia, Beardsley (1976) for the Hawaiian Islands, Hayat *et al.* (1975), Shafee *et al.* (1975) and Alam & Shafee (1982) for India. Unfortunately most of these keys are now obsolete or very incomplete.

The fauna of the Indian subcontinent is probably the best known of any within the region, except perhaps that of Australia. Even so, despite the work of earlier authors, e.g. Howard (*in* Howard & Ashmead, 1896), Gahan (1914), Ayyar & Margabandhu (1934*a,b*) and Mani (1935; 1939; 1941), only 30 genera and 50 species had been recorded from there by the middle of the present century. Later work by other authors, e.g. Subba Rao (1957; 1967), Agarwal (1965), Mani *et al.* (1973; 1974), Hayat *et al.* (1975), Shafee *et al.* (1975), added many more species and genera. Several papers have since been published to clarify the systematic position of many Indian genera and species, notably those of Subba Rao (1976) and Hayat (1979*b*; 1981*a,b*). More recently Hayat & Subba Rao (1981) listed 117 genera and 276 species from the Indian subcontinent.

In contrast, largely as a result of the work of A. A. Girault (1911–1941), the number of genera and species 'known' from Australia is much greater. Girault alone described some 150 genera and 347 species of Encyrtidae from that continent. Further species have been described by other authors, e.g. Walker (1839), Howard (1898*b*), Dodd (1917), Timberlake (1929), Compere (1940) and Ferrière (1947). However, until recently, most of Girault's taxa have remained unrecognised, mainly because of his inadequate descriptions and poor treatment of material, and the inaccessibility of his type-material to taxonomists outside Australia. Fortunately the work of E. C. Dahms at the Queensland Museum, Brisbane has now enabled a number of specialists to study the Girault Australian type-material, e.g. Bouček (all families except Encyrtidae, Aphelinidae and Mymaridae), De Bach & Rosen, Hayat (Aphelinidae), New (Mymaridae), and Gordh & Dahms (Encyrtidae). The work of Gordh (UCR) & Dahms (QM) overlaps with the present review since it includes detailed, illustrated, redescriptions of all encyrtid genera described by Girault from Australia. Unfortunately it is not yet available but should be published shortly after the present review. Therefore we are unable to include comment on their opinions concerning these genera and many of the species included in them by Girault. However, in discussion with both Gordh and Dahms it is apparent that there is a large measure of agreement between us concerning the status of many of Girault's genera and the placement of most species, but at the same time there is also some disagreement. The latter is inevitable considering the state of many of Girault's types, but at least it may show where future

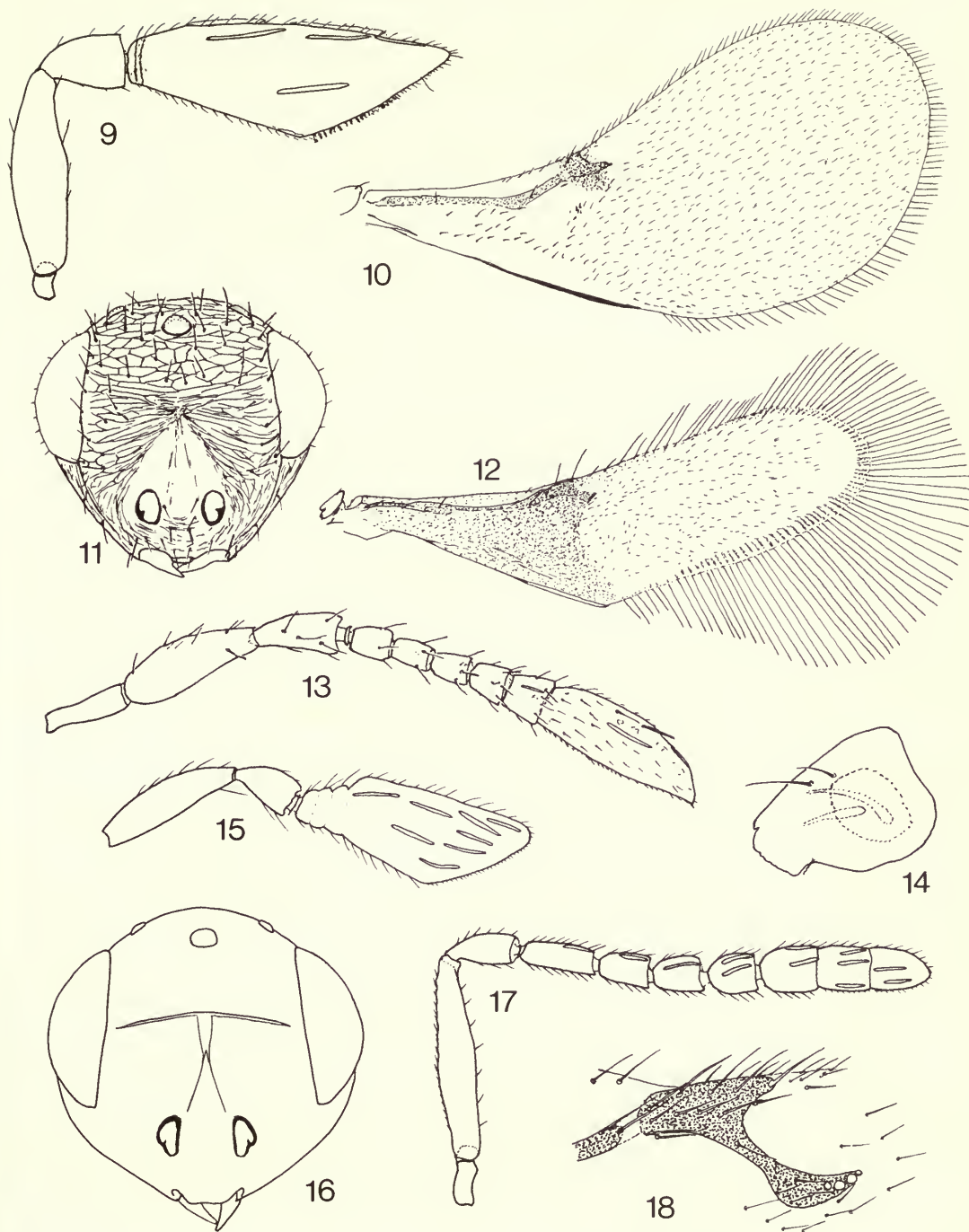

Figs 9-18 9-11, *Arrhenophagus* sp., (9) right antenna, outer aspect, ♀, (10) right forewing, upper surface, ♀, (11) head, frontal aspect, ♀; 12-14, *Anthemus maculatus* Subba Rao, (12) right forewing, upper surface, ♀, (13) right antenna, outer aspect, ♀ (14) right mandible, ♀; 15, 16, *Arrhenophagoidea bicoloripes* Girault, (15) right antenna, outer aspect, ♀, (16) head, frontal aspect, ♀; 17, 18, *Cercobelus jugaeus* (Walker) (extra-limital species), (17) left antenna, inner aspect, ♀, (18) apex of right forewing venation, upper surface, ♀.

–	Propodeum medially not more than one-fifth as long as scutellum (Figs 34, 35)	77
74 (73)	Antenna with scape broadened and flattened, not more than three times as long as broad	75
–	Antenna with scape not strongly flattened, at least five times as long as broad	76
75 (74)	Clava solid; scutellum concave with a line of scale-like setae at apex	
	COELASPIDIA (p. 225)	
–	Clava three-segmented, scutellum flat or convex without an apical line of scale-like setae	XENANUSIA (p. 347)
76 (74)	Pronotum long, medially clearly much longer than mesoscutum, mandible bidentate	SCHILLERIELLA (p. 338)
–	Pronotum medially shorter than mesoscutum (Fig. 33); mandible with three teeth	SAKENCYRTUS (p. 336)
77 (73)	Antenna with all segments broadened and flattened	MIRA (p. 299)
–	Antenna with pedicel and flagellum more or less cylindrical, scape occasionally broadened and flattened	78
78 (77)	All funicle segments longer than pedicel (Fig. 37); either funicle seven-segmented and clava two-segmented, or flagellum not differentiated into funicle and clava	ANOMALICORNIA (p. 232)
	Not all funicle segments longer than pedicel; funicle six-segmented and clava two- or three-segmented	79
79 (78)	Visible part of mesoscutum at least three times as broad as long (Fig. 34) or mesoscutum completely hidden by pronotum	80
–	Visible part of mesoscutum not more than two and one-half times as broad as long	81
80 (79)	Wings moderately long and capable of meeting at apex of scutellum; fronto-vertex at narrowest point not more than one and one-half times as broad as length of scape; mandible with three teeth	AUSTROCHOREIA (p. 237)
–	Wings very short, clearly not capable of meeting at mid-line; frontovertex at narrowest point twice as wide as length of scape; mandible bidentate	
	NEODUSMETIA (p. 306)	
81 (79)	Antennal toruli very high on head, separated from mouth margin by more than their own lengths; head and thorax covered with very conspicuous dark setae; mandible with one or two teeth and a truncation	HUNTERELLUS (p. 288)
–	Antennal toruli separated from mouth margin by less than their own lengths; head and thorax not conspicuously hairy; mandible bidentate	82
82 (81)	Body not dorso-ventrally flattened; pronotum entire (Fig. 35)	83
–	Body dorso-ventrally flattened; pronotum longitudinally divided in middle (Fig. 38)	84
83 (82)	Antennal flagellum with brown and white segments (Fig. 36); posterior margin of eye straight or slightly convex	CREMESINA (p. 260)
–	Antennal flagellum unicolorous, dark brown; posterior margin of eye concave so that eye has a kidney-shaped appearance	PARECTROMOIDELLA (p. 319)
84 (82)	Eye larger, longer than malar space (Fig. 40)	RHOPUS (p. 332)
–	Eye smaller, at least a little shorter than malar space (Fig. 39)	HAMUSENCYRTUS (p. 283)
85 (5)	Antenna with all segments distinctly broadened and flattened (Fig. 41)	
	CERAPTEROCERUS (p. 245)	
–	Antenna with pedicel and flagellum more or less cylindrical, scape occasionally broadened and flattened	86

Figs 19–30 19, 20, *Spaniopterus crucifer* Gahan, (19) right antenna, outer aspect, ♀, (20) left forewing, upper surface, ♀; 21, 22, *Tetracnemoidea indica* (Ayyar), (21) left antenna, outer aspect, ♂, (22) base of left forewing, upper surface, ♀; 23, *Acerophagus solidus* Hayat, left antenna, inner aspect, ♀; 24, *Indaphycus planus* Hayat, pronotum, mesoscutum and scutellum, dorsal aspect, ♀; 25, *Pseudaphycus utilis* Timberlake, head, frontal aspect, ♀; 26, 27, *Pseudaphycus orientalis* Ferrière, (26) right antenna, outer aspect, ♀, (27) base of right forewing, upper surface, ♀; 28, *Pseudectroma* sp., right antenna, inner aspect (clava slightly collapsed), ♀; 29, 30, *Copidosomopsis nacoleiae* (Eady), (29) right antenna, outer aspect showing truncate sensory surface at apex of clava, ♀, (30) base of left forewing, upper surface, ♀.

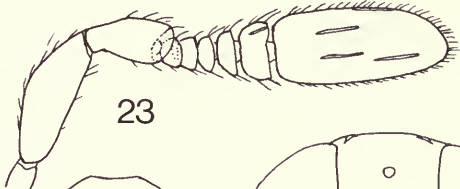
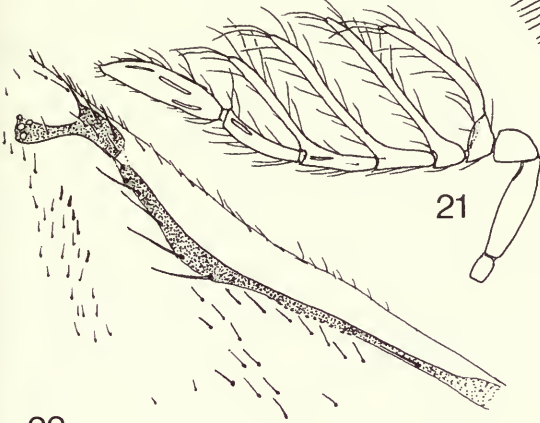
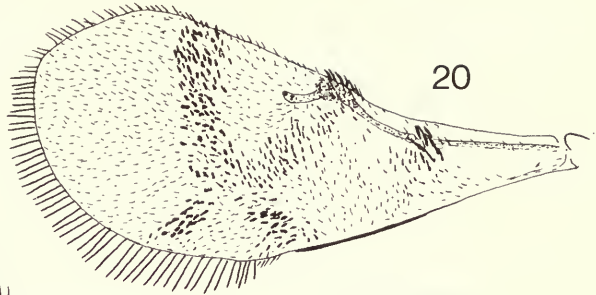

22

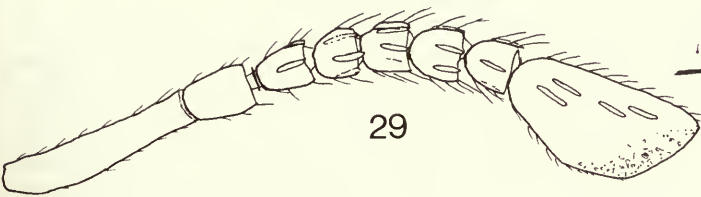
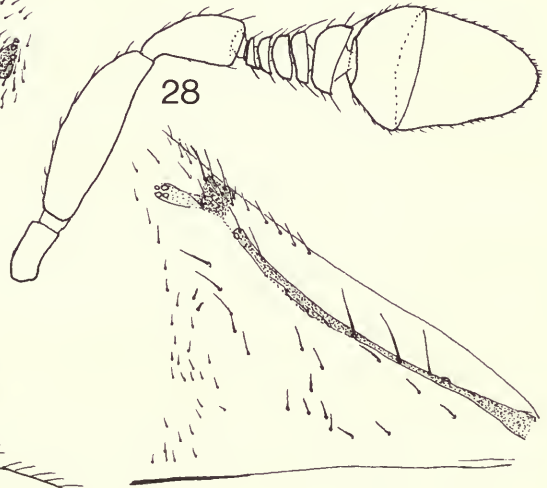
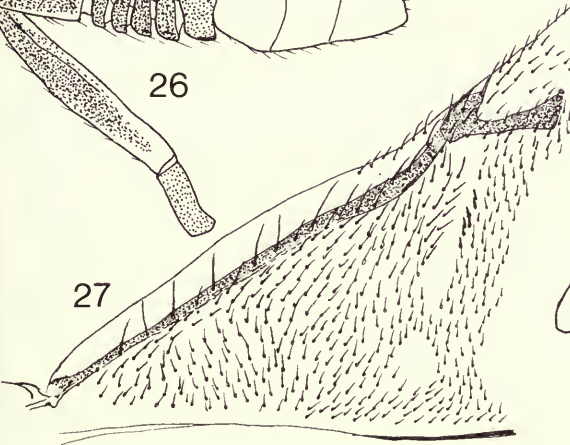
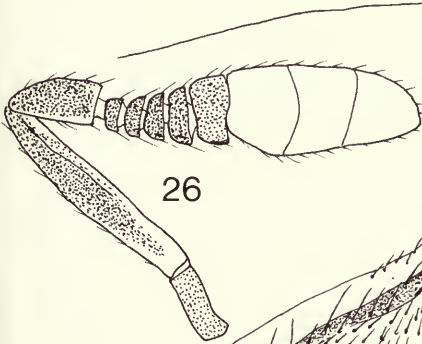
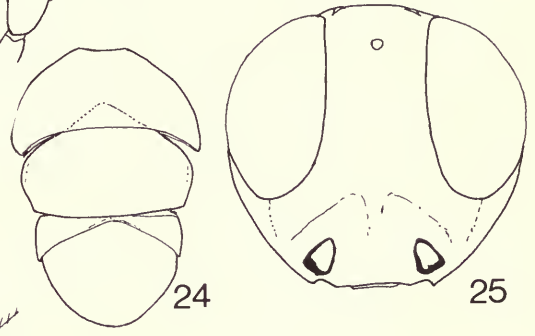

30

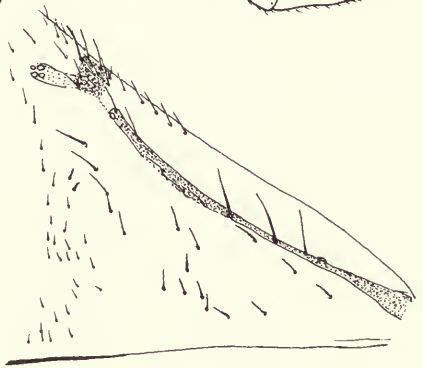

86 (85)	Scutellum with a subapical group of dark coarse setae arranged in a more or less compact bundle (as in Fig. 47)	87
–	Scutellum without such a group of setae	88
87 (86)	Mesoscutum with a distinct transverse depression in its posterior one-third; either mesoscutum with a more or less distinct bundle of setae in middle or posterior margin or pronotum has a line of stiff black bristles . . . <i>DIVERSINERVUS</i> (p. 265)	
–	Mesoscutum without a transverse posterior depression; neither mesoscutum with a median bundle of setae nor posterior margin of pronotum with a line of stiff black bristles <i>CHEILONEURUS</i> (p. 249)	
88 (86)	Mesoscutum (including part hidden by pronotum) strongly transverse, at least about three times as broad as long and entirely or almost entirely covered by posterior margin of pronotum; mandible with three acute teeth <i>AUSTROCHOREIA</i> (p. 237)	
–	Mesoscutum (including part hidden by pronotum) not or hardly more than twice as broad as long and only slightly covered by pronotum anteriorly, or if about three times as broad as long then mesoscutum only slightly covered by pronotum anteriorly <i>and</i> mandible with one or two teeth and a truncation . . .	89
89 (88)	Thorax entirely dark and metallic, not partly yellow or orange	90
–	Thorax at least partly yellow or orange	92
90 (89)	Clava with a strong oblique apical truncation (as in Fig. 43); posterior margin of mesoscutum more or less straight and not projecting over axillae so that when thorax viewed from above the axillae more or less meet (Fig. 42); gaster entirely dark; mandible with three acute teeth <i>HYPERGONATOPUS</i> (p. 288)	
–	Clava apically more or less rounded (Fig. 45); posterior margin of mesoscutum covering axillae in middle so that when thorax viewed from above the axillae appear to be widely separated (Fig. 44); gaster often orange or yellow at base; mandible usually with one or two teeth and a truncation, although occasionally obscurely tridentate	91
91 (90)	Forewing with at least apex infusate <i>XENOENCYRTUS</i> (p. 348)	
–	Forewing hyaline <i>OOENCYRTUS</i> (p. 309)	
92 (89)	Scutellum with a thin apical flange <i>PARAPHAENODISCUS</i> (p. 317)	
–	Scutellum without a distinct apical flange	93
93 (92)	Wing entirely hyaline <i>ECTROMA</i> (p. 268)	
–	Wing infusate	94
94 (93)	Pronotum with a pair of distinct, sublateral, elongate white spots <i>*PROCHEILONEURUS</i> Girault (p. 326)	
–	Pronotum unicolorous, without a pair of sublateral white spots <i>MICROTERTYS</i> (p. 299)	
95 (6)	Scutellum with two or more scale-like setae	96
–	Scutellum with a group of coarse, long, dark setae arranged in a more or less compact bundle	98
96 (95)	Apical one-third or so of scutellum with a few short, scale-like setae and with a pair of slightly larger scale-like setae at apex (Fig. 46); forewing more or less uniformly infusate; head and thorax mostly yellow <i>LAKSHAPHAGUS</i> (p. 291)	
–	Apex of scutellum with conspicuously longer, more distinctly scale-like setae than remainder, these occasionally very large and up to 12 or more in number (Fig. 48); forewing infusate with well-defined hyaline areas; body wholly dark and metallic	97

* Not to be confused with *Prochiloneurus* Silvestri (p. 327)

Figs 31–41 31, *Trechnites flavipes* (Mercet) (extra-limital species), base of right forewing, upper surface, ♀; 32, *Coccidaphycus* sp., base of right forewing, upper surface, ♀; 33, *Sakencyrtus* sp., thorax, dorsal aspect, ♀; 34, *Neodusmetia sangwani* (Subba Rao), thorax, dorsal aspect, ♀; 35, 36, *Cremesina* spp., (35) thorax, dorsal aspect, ♀, (36) right antenna, outer aspect, ♀; 37, *Anomalicornia* sp., right antenna, outer aspect, ♀; 38, 39, *Hamusencyrtus mymaricoides* (Compere, Subba Rao & Kaur), (38) pronotum, mesoscutum and scutellum, dorsal aspect, ♀, (39) head, frontal aspect, ♀; 40, *Rhopus* sp., head, frontal aspect, ♀; 41, *Cerapterocerus mirabilis* Westwood (extra-limital species), right antenna, outer aspect, ♀.

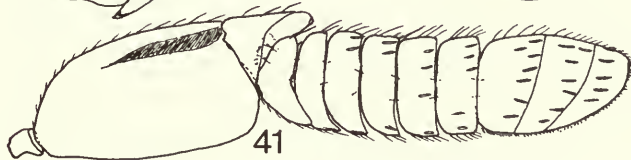
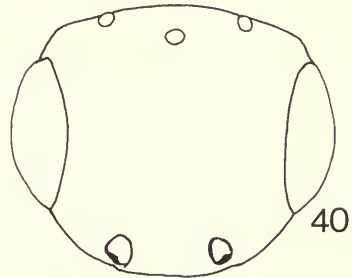
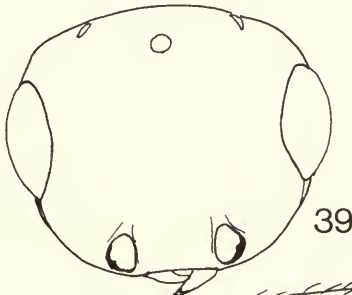
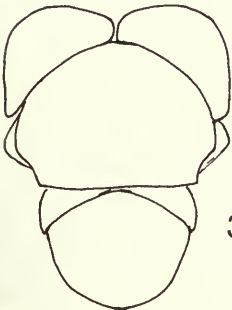
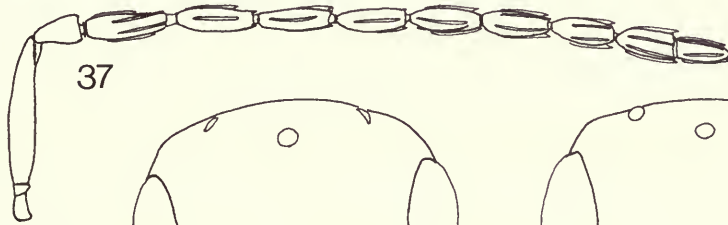
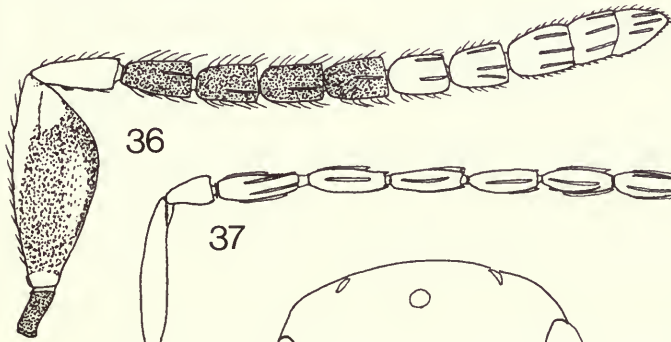
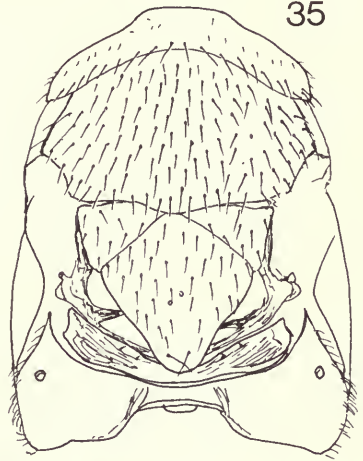
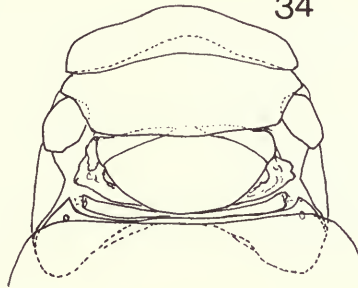
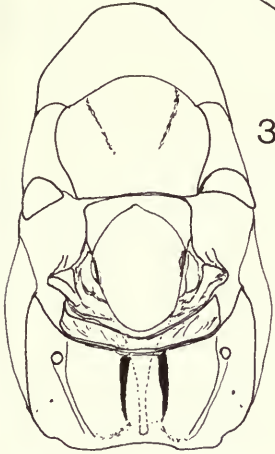
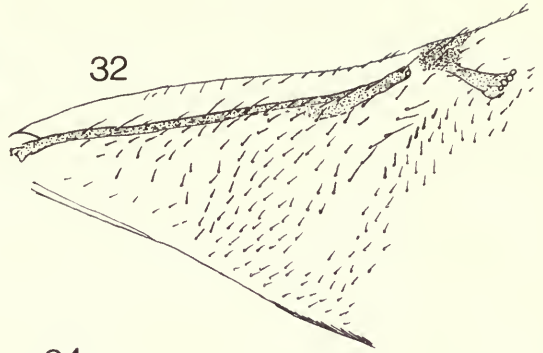
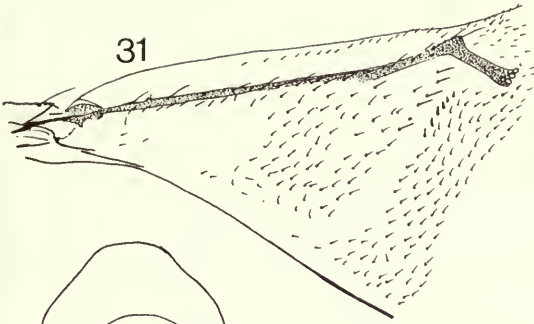

97 (96)	Apex of scutellum with about 10 to 14 long, slightly flattened, scale-like setae arranged in a line	RUSKINIANA (p. 336)
-	Apex of scutellum with at most two pairs, usually only with one, of slightly to strongly broadened and flattened scale-like setae (Fig. 48)	HABROLEPIS (p. 281)
98 (95)	Mesoscutum with a group of coarse, long, dark setae arranged in a more or less compact bundle and with a transverse depression in posterior one-third which bears silvery white setae	DIVERSINERVUS (p. 265)
-	Mesoscutum without such a bundle of setae, posterior one-third without a transverse depression, although occasionally with silvery white setae	99
99 (98)	Forewing with marginal vein at most only a little longer than broad, several times shorter than either stigmal or postmarginal veins; mandible edentate with a rounded, sharp edge	ENCYRTUS (p. 268)
-	Forewing with marginal vein at least nearly as long as stigmal; mandible with three teeth or two teeth and a truncation	100
100 (99)	Forewing hyaline	101
-	Forewing infusate	102
101 (100)	Forewing with marginal vein at least three times as long as stigmal, parastigma strongly downcurved (Fig. 50)	CHEILONEURUS (p. 249)
-	Forewing with marginal vein only slightly longer than stigmal, parastigma normal (Fig. 49)	ZAOMMA (p. 349)
102 (100)	Forewing with a pair of interrupted hyaline fasciae distad of apex of venation, marginal vein not longer than stigmal	MICROTERTYS (p. 299)
-	Forewing without hyaline fasciae distad of apex of venation, marginal vein at least twice as long as stigmal	103
103 (102)	Hypopygium extending to apex of gaster; ovipositor always strongly exerted, the exerted part at least one-third as long as gaster	*PROCHILONEURUS Silvestri (p. 327)
-	Hypopygium not extending more than three-quarters along gaster; either ovipositor not or hardly exerted, or if strongly so then hypopygium hardly extends more than half way along gaster	CHEILONEURUS (p. 249)
104 (8)	Forewing with a pattern of infusate rays or bands	105
-	Forewing hyaline or more or less uniformly infusate with one or two hyaline spots or bands, not with infusate rays or bands	109
105 (104)	Forewing with one or two longitudinal infusate rays (Fig. 303)	COMPERIELLA (p. 256)
-	Forewing with one or two fuscous fasciae or with several fuscous lines radiating from a longitudinal fuscous line in centre of wing between which are wedge-shaped hyaline spots (Fig. 292)	106
106 (105)	Hypopygium reaching apex of gaster; mandible bidentate	107
-	Hypopygium not reaching more than half way along gaster; mandible with three teeth	108
107 (106)	Forewing with a central longitudinal fuscous line from which radiate several fuscous lines between which are wedge-shaped triangular spots; scape more or less rectangular in profile	XENANUSIA (p. 347)
-	Forewing with fuscous fasciae; scape triangular in profile	EPANUSIA (p. 271)
108 (106)	Scape triangular in shape (Fig. 289); submarginal vein of forewing without a subapical triangular expansion (Fig. 290)	CERAPTEROCEROIDES (p. 245)

*Not to be confused with *Procheiloneurus* Girault (p. 326)

Figs 42–53 42, 43, *Hypergonatopus hawaiiensis* (Perkins), (42) pronotum, mesoscutum and scutellum, dorsal aspect (from card-mounted specimen), ♀, (43) left antenna, outer aspect (from card-mounted specimen), ♀; 44, 45, *Xenoencyrtus niger* Riek, (44) pronotum, mesoscutum and scutellum, dorsal aspect, ♀, (45) right antenna, outer aspect, ♀; 46, *Lakshaphagus daulai* (Shafee, Alam & Agarwal), scutellum, dorsal aspect (from card-mounted specimen), ♀; 47, *Cheiloneurus pyrillae* Mani, scutellum, dorsal aspect, ♀; 48, *Habrolepis rouxi* Compere, scutellum, dorsal aspect, ♀; 49, *Zaomma* sp., base of right forewing, upper surface, ♀; 50, *Cheiloneurus* sp., base of right forewing, upper surface (from card-mounted specimen), ♀; 51, *Eusemion cornigerum* (Walker), right antenna, outer aspect, ♀; 52, *Anicetus integrellus* Trjapitzin, left antenna, outer aspect, ♀; 53, *Leurocerus hongkongensis* Subba Rao, right antenna, outer aspect, ♀.

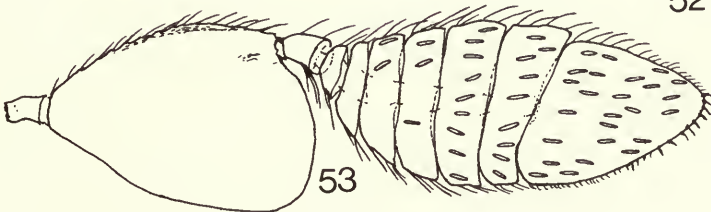
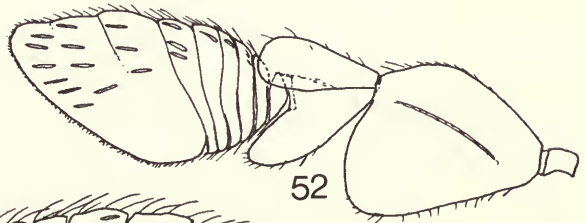
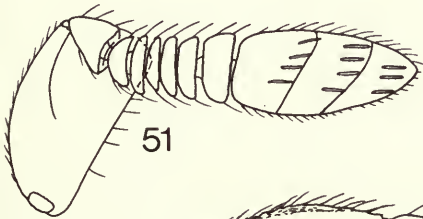
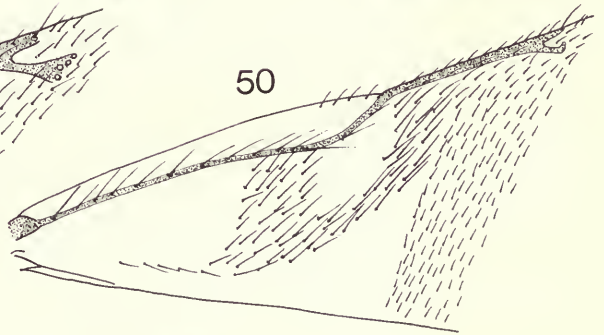
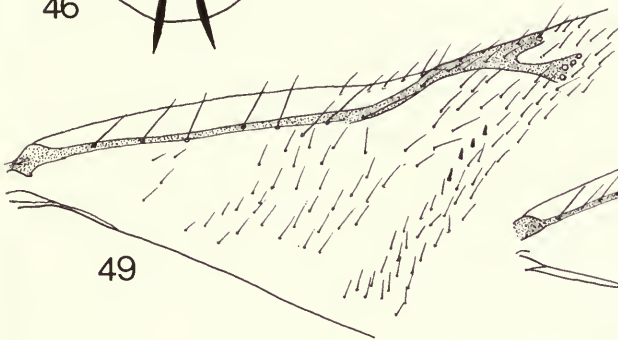
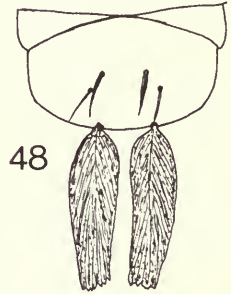
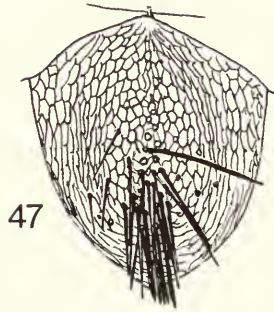
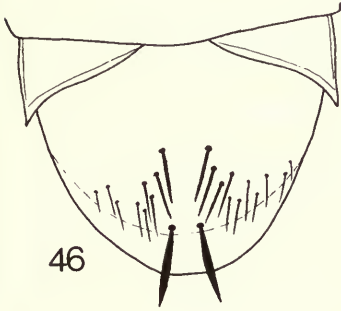
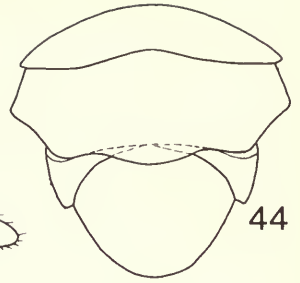
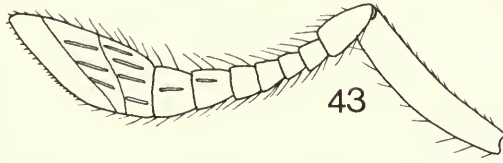
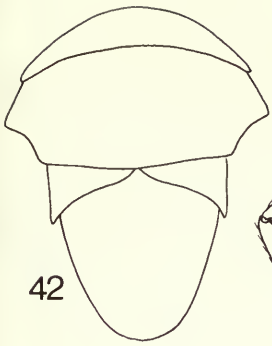

- Scape more or less rectangular with dorsal and ventral margins subparallel; submarginal vein of forewing with a subapical triangular expansion (Fig. 291) **CERAPTEROCERUS** (p. 245)
- 109 (104) Hypopygium not reaching more than about two-thirds along gaster; mandible with two teeth and a truncation, or three or four teeth 110
- Hypopygium reaching apex of gaster; mandible with two, rarely three, teeth .. 114
- 110 (109) Forewing hyaline **NEOCLADELLA** (p. 305)
- Forewing darkened 111
- 111 (110) Body dark and metallic, not yellow or orange 112
- At least head and thorax largely yellow or orange 113
- 112 (111) Forewing entirely infusate, the infuscation gradually fading towards apex of wing; clava entire (Fig. 53); marginal vein of forewing punctiform **LEUROCERUS** (p. 293)
- Forewing with apex broadly hyaline; clava three-segmented (Fig. 51); marginal vein of forewing more than twice as long as broad **EUSEMION** (p. 277)
- 113 (111) Scape tending to be subrectangular, the flattened part of upper edge more than one-half as long as the straight part of the lower edge . . **PARACERAPTROCERUS** (p. 315)
- Scape tending to be triangular, the flattened part of the upper edge less than half as long as the straight part of the lower edge (Fig. 52) **ANICETUS** (p. 231)
- 114 (109) Forewing with postmarginal vein well developed, at most only about one-third shorter than stigmal; pedicel usually longer and broader than first funicle segment 115
- Forewing with postmarginal vein very short or absent; pedicel narrower than and at most about as long as first funicle segment 117
- 115 (114) Forewing with basal cell as densely and as evenly hairy as disc, linea calva closed towards posterior margin, wing with a well-defined but irregular pattern; thorax with punctate-reticulate sculpture and matt; facial carina dorsally with two or three lines of very short, white squamous hairs . . . **CERAPTROCERELLA** (p. 246)
- Forewing with basal cell naked proximally, linea calva more or less open posteriorly (Fig. 55), wing more or less evenly infusate except in proximal one-quarter where it is more or less hyaline; thorax with very shallow sculpture and slightly to very shiny; facial carina without a distinct line of pale setae dorsally 116
- 116 (115) Forewing with proximal margin of linea calva with at least a few flattened scale-like setae (Fig. 55); antennal flagellum in profile with subparallel sides (Fig. 54) **CHRYSOPLATYCERUS** (p. 250)
- Forewing with proximal margin of linea calva without any flattened scale-like setae; antennal flagellum distinctly oval in profile (Fig. 56) . . . **NEOPLATYCERUS** (p. 306)
- 117 (114) Scutellum with a distinct, thin apical flange (Fig. 58); pedicel only slightly shorter than first funicle segment, clava solid (Fig. 57) **PRALEUROCERUS** (p. 325)
- Scutellum without a distinct apical flange; pedicel very small, much shorter than first funicle segment, clava three-segmented 118
- 118 (117) Head prognathous and in frontal view elongate, nearly one-half longer than broad **MONSTRANUSIA** (p. 300)
- Head hypognathous and in frontal view about as long as broad 119
- 119 (118) First funicle segment at least three times as broad as pedicel which is triangularly flattened, the distal segments narrowing but still at least about twice as wide as pedicel; forewing with postmarginal vein very short, almost absent **CRYPTANUSIA** (p. 262)
- First funicle segment subequal in size to sixth, both much less than twice as

Figs 54–64 54, 55, *Chrysoplatycerus splendens* (Howard), (54) right antenna, outer aspect, ♀ (55) left forewing, upper surface, ♀; 56, *Neoplatycerus* sp., left antenna, outer aspect (from card-mounted specimen), ♀; 57, 58, *Praleurocerus viridis* (Agarwal), (57) right antenna, outer aspect, ♀, (58) scutellum and propodeum, dorsal aspect, ♀; 59, 60, *Proleurocerus fulgoridis* Ferrière, (59) apex of right forewing venation, upper surface, ♀, (60) right antenna, inner aspect, ♀; 61, *Zozoros sinemarginis* sp. n., base of right forewing, upper surface, ♀; 62–64, *Hambletonia pseudococcina* Compere, (62) right antenna, outer aspect, ♀, (63) base of right forewing, upper surface, ♀, (64) head, dorso-frontal aspect, ♀.

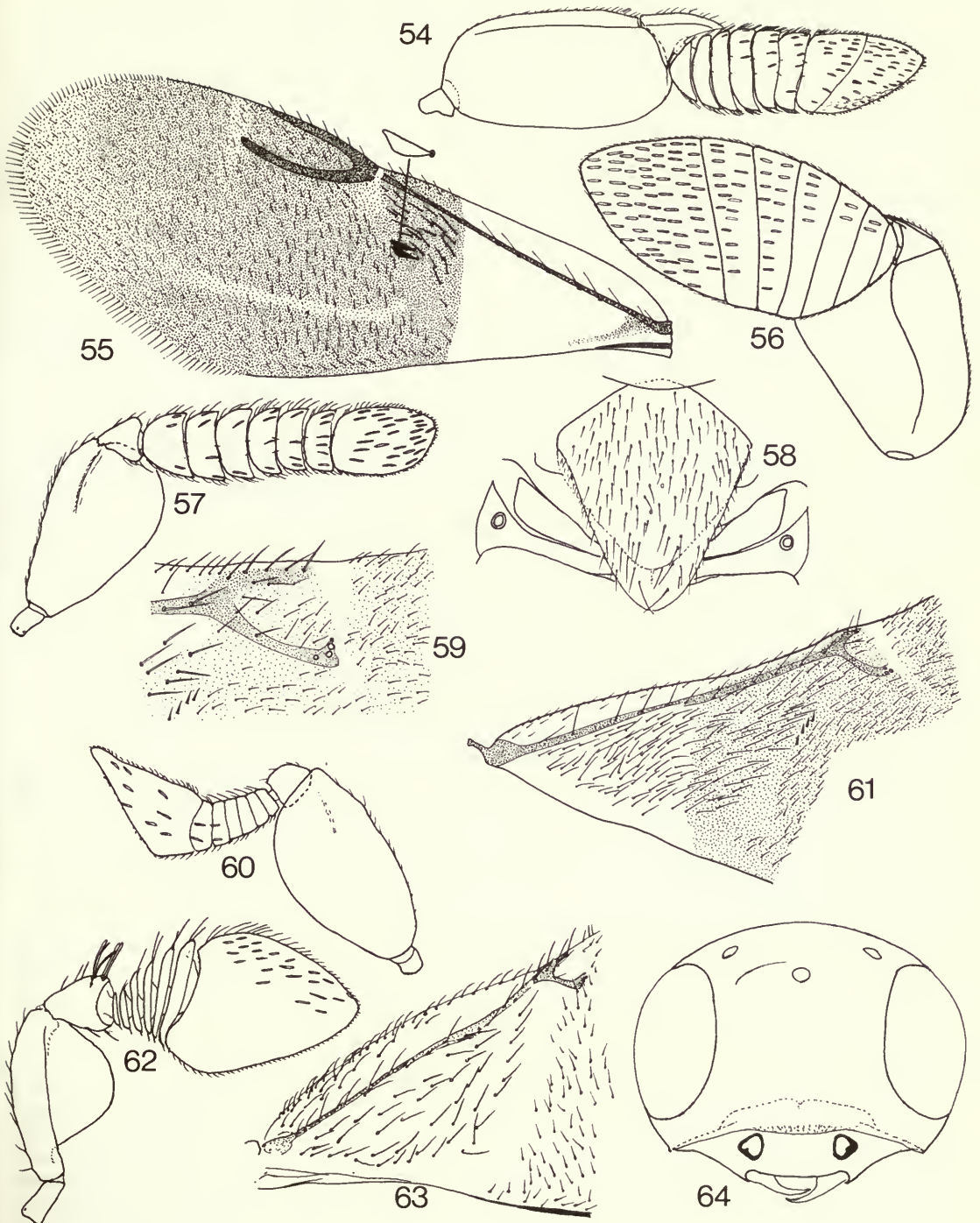

- broad as pedicel which is subconical; forewing with postmarginal vein at least about half as long as stigmal **PARECTROMOIDEA** (p. 319)
- 120 (10) Forewing either with marginal vein absent, the postmarginal and stigmal veins emitted from apex of submarginal with postmarginal vein not touching margin of wing, or marginal vein punctiform (or occasionally slightly longer than broad) and apex of stigmal vein joined to apex of postmarginal vein by a distinct, often hyaline, hairless streak (Figs 59, 61, 63) 121
- Forewing either with marginal vein distinctly longer than broad or with marginal vein punctiform (or slightly longer than broad) and without distinct naked streak from apex of postmarginal vein to apex of stigmal vein 125
- 121 (120) Clava shorter than funicle, about as long as preceding three funicle segments together **PENTELICUS** (p. 322)
- Clava at least as long as funicle, usually longer 122
- 122 (121) Pedicel with a few conspicuous long scale-like setae, clava large and oval (Fig. 63); facial impression margined above by a sharp ridge (Fig. 64) **HAMBLETONIA** (p. 282)
- Pedicel with normal setae, clava not oval; facial impression at most with a rounded edge 123
- 123 (122) Head smooth with very fine punctures; mandible bidentate **LUTHERISCA** (p. 294)
- Head with deep, conspicuous piliferous punctures; mandible with three teeth 124
- 124 (123) Clava solid, funicle segments not less than twice as broad as long (Fig. 60); body wholly dark and metallic, not partly yellow-brown **PROLEUROCERUS** (p. 328)
- Clava three-segmented, funicle segments from slightly transverse to clearly longer than broad (Fig. 65); body partly yellow-brown **ZOZOROS** (p. 350)
- 125 (120) Exserted part of ovipositor at least about one-third length of gaster ***PROCHILONEURUS** Silvestri (p. 327)
- Ovipositor not or hardly exserted 126
- 126 (125) All funicle segments broader than long 127
- Not all funicle segments broader than long, at least first funicle segment longer than broad 132
- 127 (126) Hypopygium extending to apex of gaster; forewing with marginal vein shorter than stigmal 128
- Hypopygium not extending to apex of gaster; forewing with marginal vein at least a little longer than stigmal 130
- 128 (127) Head and dorsum of thorax with fine punctate-reticulate sculpture and of matt or velvety appearance; facial impression bordered above by a very strong, almost straight transverse carina extending from gena to gena; pedicel dorsally flattened and shiny **CERAPTROCERELLA** (p. 246)
- Head and dorsum of thorax with shallow reticulate and shallow to moderately deep piliferous punctures which often give a thimble-like appearance; face without a strong transverse carina (although antennal scrobes may be very sharply margined); pedicel not flattened dorsally and not shiny 129
- 129 (128) Frontovortex one-sixth to one-third head width, head with punctures descending at least some way between eye and facial impression; mandible bidentate **AENASIUS** (p. 225)
- Frontovortex less than one-sixth head width, head only with fine punctures between eye and facial impression; mandible tridentate **NEODISCODES** (p. 306)

* Not to be confused with *Procheiloneurus* Girault (p. 326)

Figs 65–77 65, *Zozoros sinemarginis* sp. n., right antenna, outer aspect, ♀; 66, *Doddanusia* sp., base of right forewing, upper surface, ♀; 67, 68, *Ovaloencyrtus fijiensis* sp. n., (67) right antenna, outer aspect, ♀, (68) base of right forewing, upper surface, ♀; 69–71, *Paratetralophidea* sp., (69) right antenna, outer aspect, ♀, (70) left forewing showing pattern and relative strength of infuscation, ♀, (71) head, frontal aspect, ♀; 72, *Epitetracnemus zetterstedtii* (Westwood), head, aspect from left side, ♀; 73, *Paksimmond-sior pakistanensis* Ahmad & Ghani, base of right forewing, upper surface, ♀; 74, *Psyllaephagus worcesteri* (Girault), left mandible, ♀; 75, *Psyllaephagus dyari* (Girault), right mandible, ♀; 76, *Aenasiella brachyscelidis* Girault, right mandible, ♀; 77, *Lakshaphagus hautefeuilli* (Mahdihassan), apex of right forewing venation, upper surface, ♀.

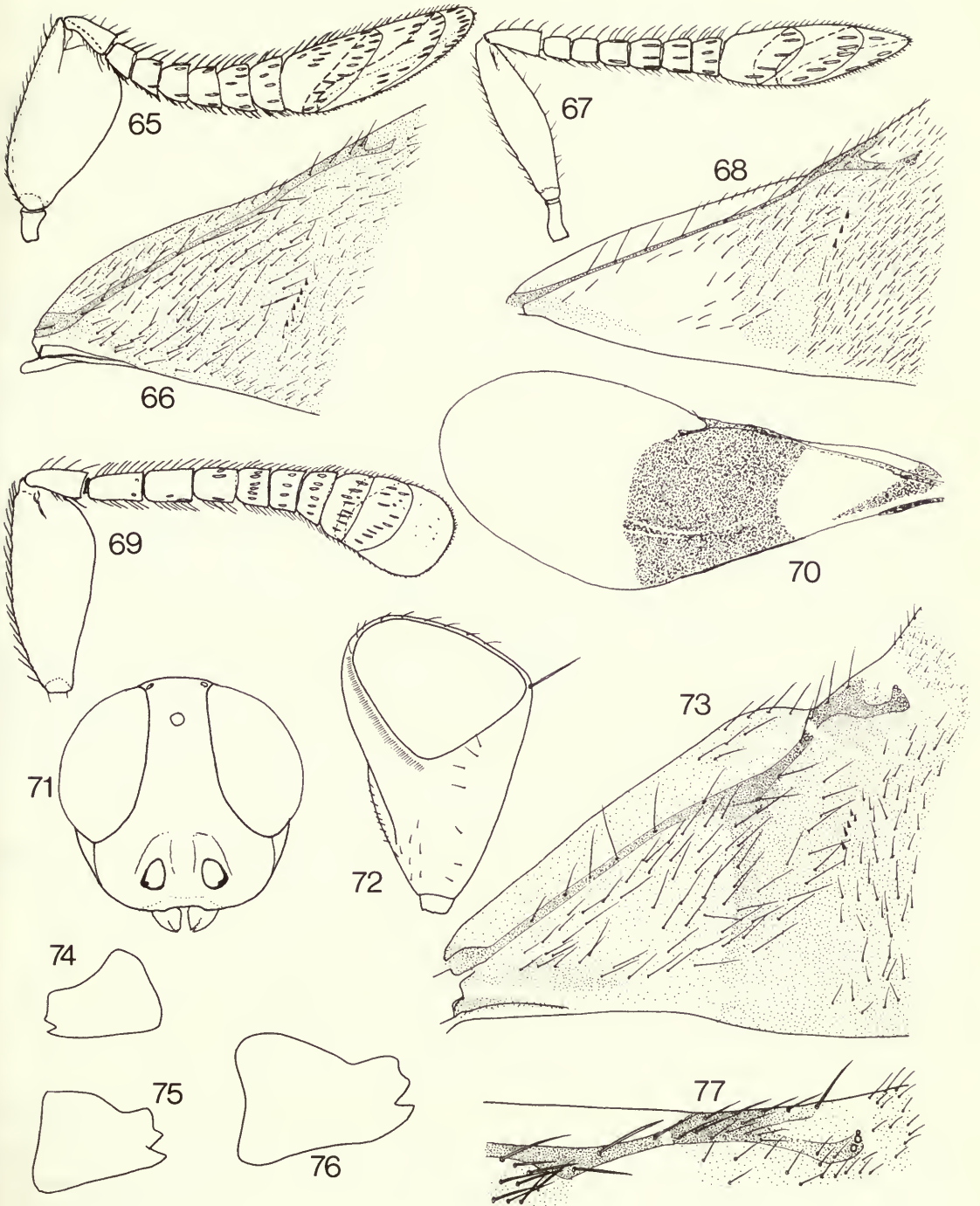

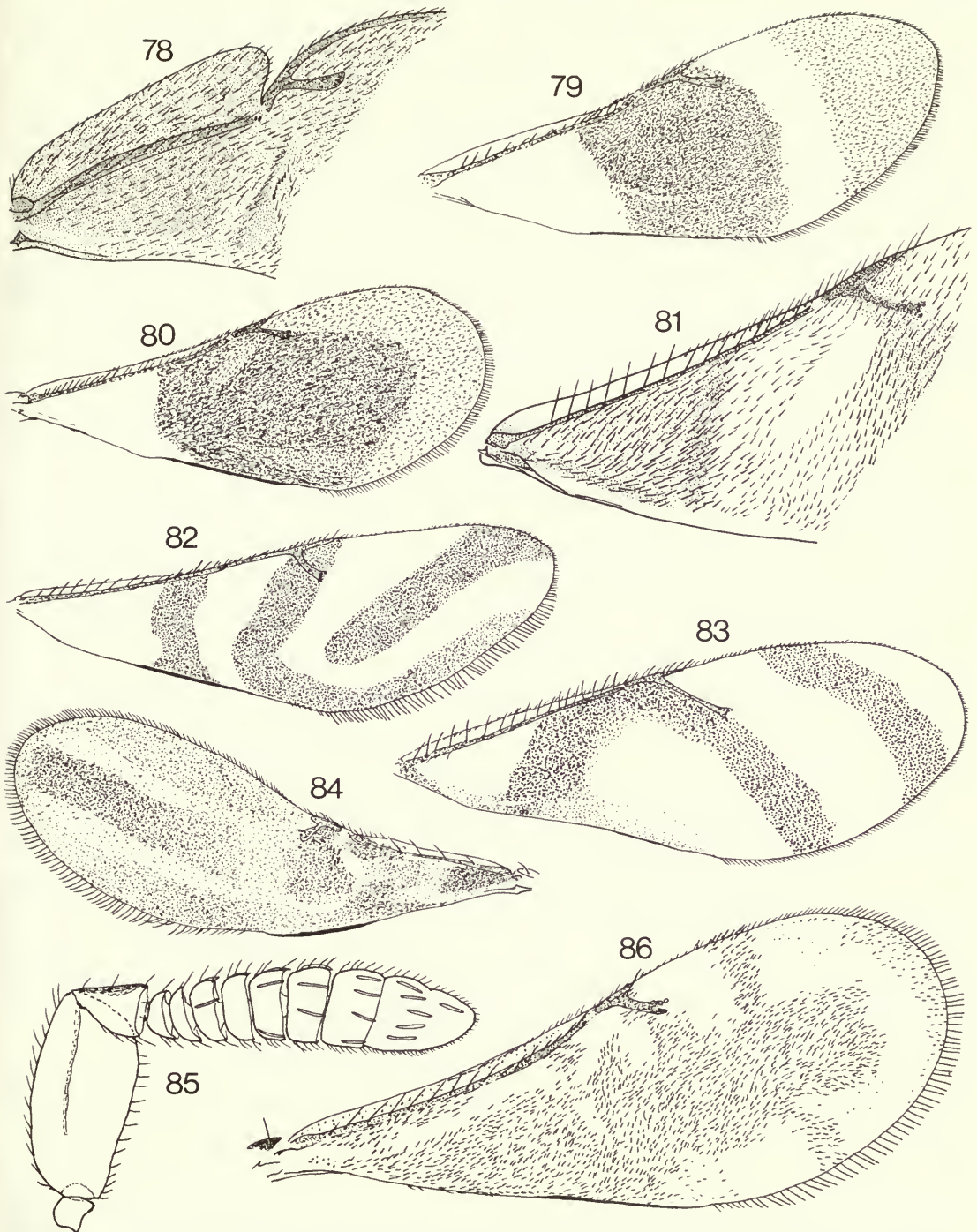

Figs 78–86 78, *Eugahania ishiharai* Tachikawa, base of right forewing, upper surface, ♀; 79, *Parectromoidella lowelli* (Girault), right forewing, ♀; 80, *Cremesina* sp., right forewing, ♀; 81, *Tongyus nesus* sp. n., base of right forewing, upper surface, ♀; 82, *Yasumatsuiola* sp., right forewing showing pattern of infuscation, ♀; 83, *Holanusomyia pulchripennis* Girault, right forewing showing pattern of infuscation, ♀; 84, 85, *Gentakola trifasciata* (Saraswat), (84) left forewing, ♀, (85) right antenna, outer aspect, ♀; 86, *Anagyrietta* sp., right forewing, ♀.

	(Fig. 72) and with a distinct transverse line of silvery white setae across face at this point and continuing below eyes	EPITETRACNEMUS (p. 273)
–	Head in profile more or less gradually anteriorly rounded, not strongly inflexed inwards at top of antennal scrobes and without a distinct transverse line of silvery white setae	141
141 (140)	Stigmal vein of forewing shorter than marginal vein	ZOOENCYRTUS (p. 350)
–	Stigmal vein of forewing longer than marginal vein	142
142 (141)	Mandible with one or two teeth and a truncation (Figs 74, 75); antenna usually with all funicle segments longer than broad, although rarely all subquadrate or transverse	PSYLLAEPHAGUS (p. 330)
–	Mandible with three acute teeth (Fig. 76); not all funicle segments longer than broad	AENASIELLA (p. 224)
143 (11)	Costal cell of forewing strongly excised at apex (Fig. 78)	EUGAHANIA (p. 276)
–	Costal cell of forewing not or hardly excised at apex	144
144 (143)	All funicle segments longer than broad; mandible always bidentate	145
–	Not all funicle segments longer than broad; mandible occasionally bidentate, but usually otherwise	151
145 (144)	Body (excluding legs) wholly dark and with silvery white setae, those on scutellum usually arranged in a distinct pattern	PARANATHRIX (p. 317)
–	Body (excluding legs) at least partly yellow or red; setae on thorax not silvery white, or if so then those on scutellum are evenly distributed and not arranged in a distinct pattern	146
146 (145)	Forewing with at least a broad fuscous band in middle one-third of wing but usually more extensively infuscate (Figs 79, 80) and not with a pattern of dark and pale setae	147
–	Either forewing less extensively infuscate, the infuscation limited to one or two narrow fasciae or to basal one-third or to small areas below venation which do not extend more than one-third across wing, or wing with a distinct pattern of dark and pale setae	148
147 (146)	Frontovertex relatively broad, at narrowest point only a little narrower than length of scape	CREMESINA (p. 260)
–	Frontovertex relatively narrow, at narrowest point less than half as wide as length of scape	PARECTROMOIDEA (p. 319)
148 (146)	Forewing with postmarginal vein longer than stigmal	149
–	Forewing with postmarginal vein not longer than stigmal	150
149 (148)	Forewing with one or two distinct fuscous bands	LEPTOMASTIDEA (p. 292)
–	Forewing with infuscation limited to longitudinal streaks adjacent to venation	GYRANUSOIDEA (p. 280)
150 (148)	Forewing with a distinct infuscate area at base and a diffuse band from stigmal vein across wing (Fig. 81) and not with a pattern of dark and pale setae, remainder hyaline; flagellar segments clearly slightly flattened from side to side	TONGYUS (p. 343)
–	Forewing more or less generally suffused pale fuscous or with only longitudinal infuscate streaks adjacent to venation or with a pattern of dark and pale setae; flagellar segments cylindrical (N.B., if material has been dried from alcohol the flagellar segments may have collapsed giving a flattened appearance)	ANAGYRUS (p. 229)
151 (144)	Eyes much shorter than minimum width of frontovertex	152
–	Eyes not shorter than minimum width of frontovertex	153

Figs 87–98 87, 88, *Alamella flava* Agarwal, (87) head, frontal aspect, ♀, (88) apex of right forewing venation, upper surface, ♀; 89, 90, *Philosindia longicornis* sp. n., (89) head, frontal aspect, ♀, (90) apex of right forewing venation, upper surface (discal setae omitted), ♀; 91, *Rhopus* sp., right forewing, ♀; 92, *Hamusencyrtus* sp., right forewing, ♀; 93, *Gyranusoidea phenacocci* (Beardsley), apex of right forewing venation, upper surface, ♀; 94, *Epidinocarsis californicus* (Compere), head, frontal aspect, ♀; 95, *Anagyruus swezeyi* Timberlake, base of right forewing, upper surface, ♀; 96, *Anagyruus antoninae* Timberlake, apex of right forewing venation, upper surface, ♀; 97, 98, *Doliphoceras nigricans* (Perkins), (97) head, frontal aspect, ♀, (98) base of right forewing, upper surface, ♀.

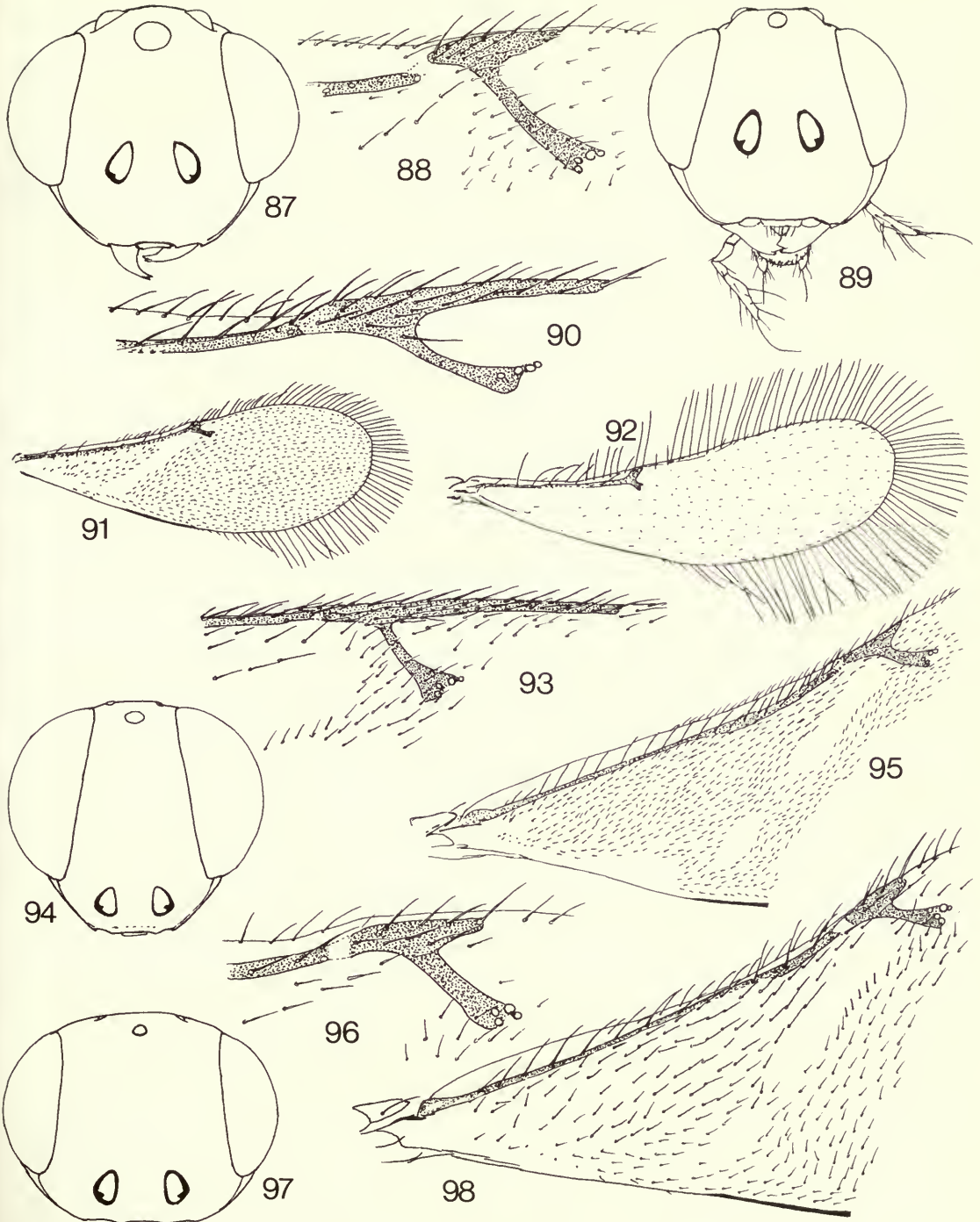

- 152 (151) Body foliaceously flattened; head prognathous; antennal toruli at mouth margin; pronotum longitudinally divided in middle (as in Fig. 38) . . . **PLATYRHOPUS** (p. 325)
 - Body not foliaceously flattened; head opisthognathous; antennal toruli separated from mouth margin by more than their own lengths; pronotum entire
HUNTERELLUS (p. 288)
- 153 (151) Exserted part of ovipositor at least about one-fifth length of gaster; notaular lines usually present in anterior part of mesoscutum **PSEUDOCOCCOBIUS** (p. 329)
 - Ovipositor not, or hardly, exserted; notaular lines completely absent 154
- 154 (153) Forewing with marginal vein absent, stigmal vein arising directly from submarginal vein before it reaches anterior margin of wing, costal cell very slightly incised at apex; antennal scrobes bordered dorsally and laterally by a very sharp carina; clava solid **TROPIDOPHYNE** (p. 346)
 - Forewing with marginal vein at least a little longer than broad, costal cell not incised at apex; antennal scrobes not bordered above or at sides by a sharp carina; clava two- or three-segmented 155
- 155 (154) Clava two-segmented (Fig. 85); forewing with venation not reaching half way along wing (Fig. 84); mandible with three teeth **GENTAKOLA** (p. 278)
 - Clava three-segmented; forewing with venation extending more than half way along wing; mandible bidentate 156
- 156 (155) First funicle segment not longer than pedicel 157
 - First funicle segment longer than pedicel 158
- 157 (156) Forewing with a pattern of radiating darker setae interspersed with wedge-shaped paler areas and hyaline fasciae (Fig. 86); legs more or less unicolorous yellow **ANAGYRIETTA** (p. 228)
 - Forewing largely infuscate without radiating fuscous areas but with a transverse hyaline band (occasionally apical one-third of forewing entirely hyaline) at apex of venation (Fig. 79); legs at least partly strongly infuscate
PARECTROMOIDEA (p. 319)
- 158 (156) Forewing with stigmal vein very long, nearly one-quarter length of venation from origin of submarginal vein to apex of postmarginal vein; apex of costal cell and submarginal vein distinct (Figs 83, 355) **HOLANUSOMYIA** (p. 286)
 Forewing with stigmal vein less than one-eighth as long as combined lengths of submarginal, marginal and postmarginal veins; apex of costal cell not easily distinguishable (i.e. difficult to make out where submarginal vein ends and marginal vein begins) (Fig. 82) **YASUMATSUIOLA** (p. 348)
- 159 (12) Antennal toruli more than their own lengths from mouth margin, their lower margins not below the lower eye margin when head viewed from front (Figs 87, 89), or if slightly so then first funicle segment at least about twice as long as pedicel 160
 - Antennal toruli much less than their own lengths from mouth margin, or if more then their lower margins are clearly below lower eye margins when head viewed from front and first funicle segment not or hardly longer than pedicel 162
- 160 (159) Forewing with postmarginal vein at least as long as stigmal (Fig. 90); hypopygium not reaching apex of gaster **PHILOSINDIA** (p. 323)
 - Forewing with postmarginal vein shorter than stigmal (Fig. 88); hypopygium reaching apex of gaster 161
- 161 (160) Mandible bidentate; forewing with linea calva interrupted on dorsal surface of

Figs 99–109 99, *Rhytidothorax ?marlatti* Ashmead (extra-limital species), scutellum and propodeum, dorsal aspect, ♀; 100, *Coelopencyrtus mauiensis* Timberlake, scutellum and propodeum, dorsal aspect, ♀; 101, *Neastymachus auraticorpus* Girault, thorax, aspect from left side, ♀; 102, *Psyllaephus* sp., thorax, aspect from left side, ♀; 103, *Erencyrtus dewitzii* Mahdihassan, base of left forewing, upper surface, ♀; 104, *Metaphycus helvolus* (Compere), base of right forewing, upper surface, ♀; 105, 106, *Avetianella* sp., (105) head, frontal aspect, ♀, (106) right antenna, outer aspect, ♀; 107, *Tyndarichus* sp., base of right forewing, upper surface, ♀; 108, 109, *Tyndaricopsis clavatus* (Eady), (108) right antenna, outer aspect, ♀, (109) base of right forewing, upper surface, ♀.



99

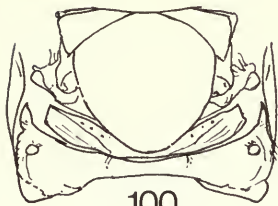

100

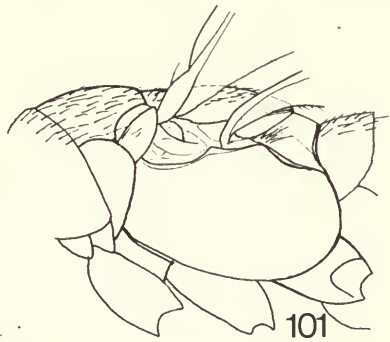

101

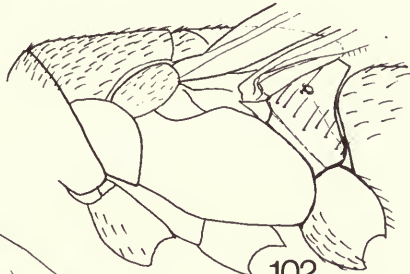

102

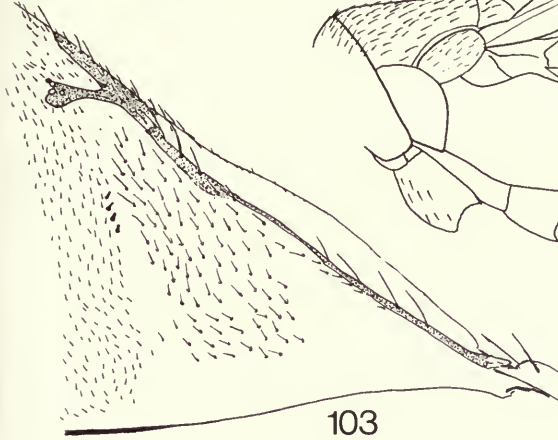

103

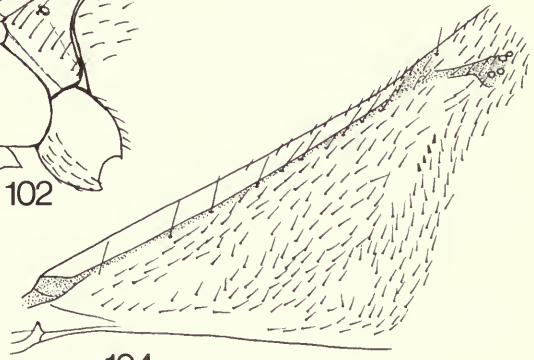

104

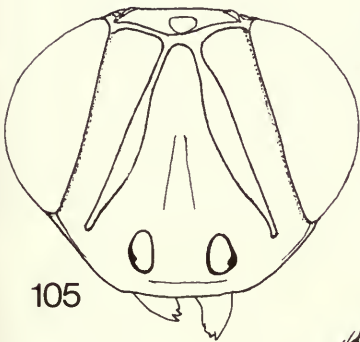

105

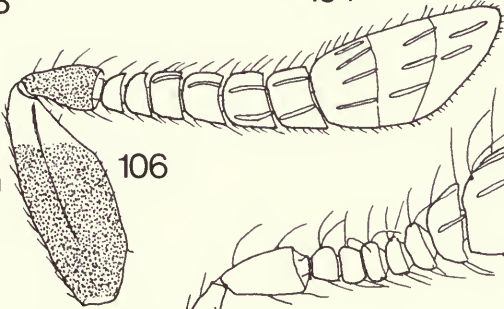

106

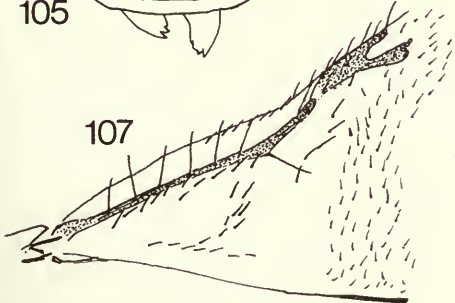

107

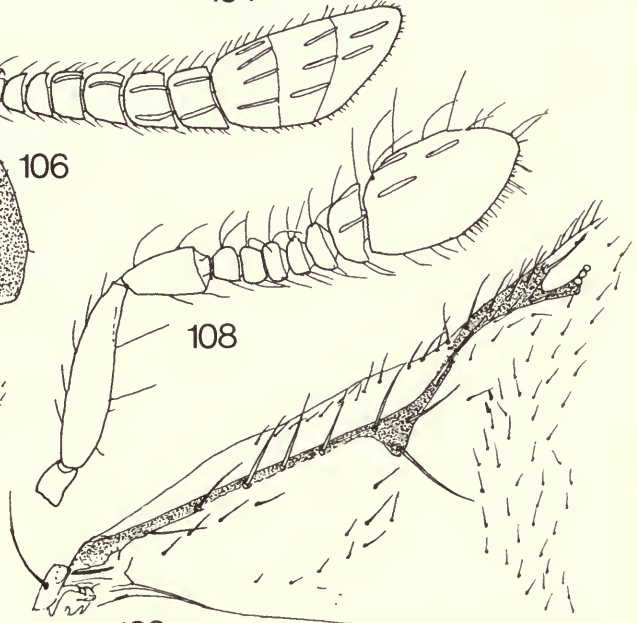

108

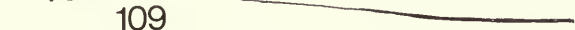

109

	wing by two or three lines of setae and also more or less closed near posterior margin	ALAMELLA (p. 227)
-	Mandible tridentate; forewing with linea calva uninterrupted (except perhaps by one or two setae) and open posteriorly	162
162 (159, 161)	Hypopygium extending to apex of gaster	163
-	Hypopygium not reaching more than two-thirds along gaster	177
163 (162)	Exserted part of ovipositor at least one-fifth as long as gaster	164
-	Ovipositor not or hardly exserted	168
164 (163)	Mandible bidentate; stigmal vein of forewing without a distinct apical uncus (Figs 95, 96, 98); notaular lines completely absent	165
-	Mandible tridentate; stigmal vein of forewing with a distinct apical uncus; notaular lines often present in anterior part of mesoscutum	166
165 (164)	Head and thorax with very fine punctate-reticulate or vermiculate sculpture which gives it a silky or velvety appearance	ANAGYRUS (p. 229)
-	Head and thorax with shallow reticulate sculpture and relatively shiny	DOLIPHOCERAS (p. 266)
166 (164)	Forewing with linea calva not interrupted (except perhaps by one or two setae) on dorsal surface of wing; notaular lines completely absent	PARAPHYCUS (p. 317)
-	Either linea calva interrupted on dorsal surface of forewing by two or three lines of setae, or notaular lines present in anterior part of mesoscutum	167
167 (166)	Clava clearly shorter than funicle	AENASIOIDEA (p. 225)
-	Clava at least as long as funicle	PSEUDOCOCCOBIUS (p. 329)
168 (163)	Notaular lines completely absent	169
-	Notaular lines present in anterior part of mesoscutum	177
169 (168)	Body strongly dorso-ventrally flattened; pronotum longitudinally divided in middle (Fig. 38)	170
-	Body not or hardly dorso-ventrally flattened; pronotum entire	171
170 (169)	Forewing with linea calva poorly defined (Fig. 92); eyes smaller and not longer than malar space (Fig. 39)	HAMUSENCYRTUS (p. 283)
-	Forewing with well-defined linea calva (Figs 91, 414); eyes larger and longer than malar space (Fig. 40)	RHOPUS (p. 332)
171 (169)	Forewing with linea calva interrupted on dorsal surface by at least two lines of setae and filum spinosum absent (Figs 95, 98); mandible with two equal teeth	172
-	Forewing with linea calva not interrupted on dorsal surface by more than two or three setae and with filum spinosum present (Figs 103, 104, 248, 394); mandible with one to three teeth, or if with two teeth then one is clearly longer than the other	175
172 (171)	Forewing with postmarginal vein at least one-quarter longer than stigmal (Fig. 93)	GYRANUSOIDEA (p. 280)
-	Forewing with postmarginal vein not or hardly longer than stigmal (Figs 95, 96, 98)	173

Figs 110–127 110, 111, *Neocladella compressipes* Girault, (110) antenna, ♀, (111) right mandible, ♀; 112, *Ectopiognatha* sp., right mandible, ♀; 113, *Gahaniella saissetiae* Timberlake, head, frontal aspect, ♀; 114, *Thomsonisca pakistanensis* (Ahmad), right antenna, outer aspect, ♀; 115, *Epitetrалophidea bicinctipes* Girault, right mandible, ♀; 116, *Adelencyrtus moderatus* (Howard), right mandible, ♀; 117, *Coccidencyrus ochraceipes* Gahan, base of right forewing, upper surface, ♀; 118, *Coelopencyrtus odyneri* Timberlake, head, frontal aspect, ♀; 119, *Coelopencyrtus kaalae* (Ashmead), head, frontal aspect, ♀; 120, *Phauloencyrtus mirisimilis* Girault, right antenna, outer aspect (from card-mounted specimen), ♀; 121, *Psyllaephagus burnsi* (Girault), right mandible, ♀; 122, *Psyllaephagus channingi* (Girault), left mandible, ♀; 123, *Rhopalencyrtoidea purpureicorpus* Girault, right mandible, ♀; 124, *Asitus phragmitis* (Ferrière), pronotum, mesoscutum and scutellum, dorsal aspect, ♀; 125, *Coccidocytus trinidadensis* Crawford (extra-limital species), gaster, dorsal aspect, ♀; 126, *Pentelicus* sp., apex of right forewing venation, upper surface, ♀; 127, *Cerchysiella* sp., base of right forewing, upper surface, ♀.

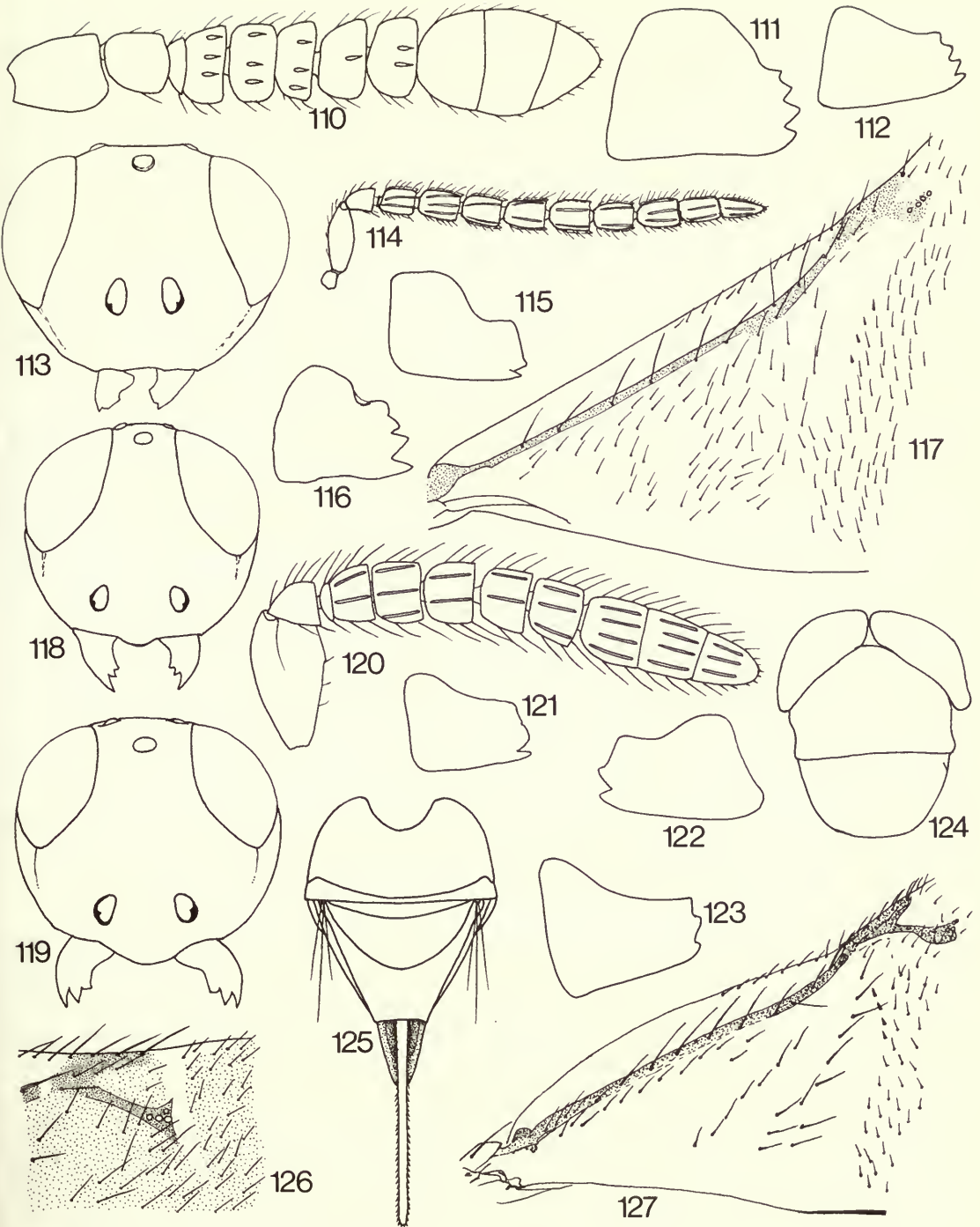

- 173 (172) Head and dorsum of thorax with very fine punctate-reticulate or vermiculate sculpture of silky appearance **ANAGYRUS** (p. 229)
 - Head and mesoscutum with shallow reticulate sculpture and at least slightly shiny 174
- 174 (173) Eye relatively small, shorter than minimum width of frontovertex (Fig. 97) **DOLIPHOCERAS** (p. 266)
 - Eye larger, clearly longer than minimum width of frontovertex (Fig. 94) **EPIDINOCARSIS** (p. 272)
- 175 (171) Mesoscutum and scutellum both strongly convex, both with striate-reticulate or distinctly elongate reticulate sculpture, scutellum never smooth and shiny **PARABLATTICIDA** (p. 314)
 - Scutellum flat, not strongly convex; mesoscutum moderately flat, neither mesoscutum nor scutellum with elongate or striate-reticulae sculpture, scutellum sometimes smooth and shiny 176
- 176 (175) Propodeum relatively long, medially at least about one-fifth as long as scutellum and with some sculpture medially (Fig. 99); scutellum usually with an apical carina (although often very fine); gonostyli always hidden, never visible; mandible usually with one or two teeth, rarely with three .. **RHYTIDOTHORAX** (p. 333)
 - Propodeum very short and smooth, medially not more than one-eighth as long as scutellum (Fig. 100) which is rounded apically and without a carina; gonostyli only slightly exerted but visible externally; mandible large and with three teeth **COELOPENCYRTUS** (p. 255)
- 177 (162, 168) Clava two-segmented **AENASOMYIELLA** (p. 226)
 - Clava three-segmented 178
- 178 (177) Forewing with postmarginal vein longer than stigmal (Fig. 103)..... **ERENCYRTUS** (p. 274)
 - Forewing with postmarginal vein not longer than stigmal 179
- 179 (178) Mesoscutum and scutellum largely metallic green..... **ZARHOPALOIDES** (p. 349)
 - Neither mesoscutum nor scutellum even partly metallic green, occasionally brown or darker but never metallic 180
- 180 (179) Forewing with linea calva interrupted or closed on dorsal surface of wing by at least one line of setae (Fig. 104); notaular lines often present on mesoscutum **METAPHYCUS** (p. 298)
 - Forewing with linea calva neither interrupted nor closed on dorsal surface of wing; notaular lines absent 181
- 181 (180) Forewing with stigmal vein less than twice as long as marginal; mesopleurum posteriorly enlarged so that when thorax is viewed from side it is more or less touching basal segment of gaster and thus clearly separating metapleurum and propodeum from hind coxa (Fig. 101) **NEASTYMACHUS** (p. 304)
 - Forewing with stigmal vein more than three times as long as marginal; mesopleurum more or less normal so that when thorax viewed from side metapleurum together with propodeum at least narrowly in contact with hind coxa and thus clearly separating it from basal segment of gaster (Fig. 102) **PSYLLAEPHAGUS** (p. 330)
- 182 (13) Clava three segmented (Fig. 106) **AVETIANELLA** (p. 239)
 - Clava entire **SZELENYIOLA** (p. 339)
- 183 (14) Submarginal vein of forewing with a subapical triangular expansion (Figs 107, 109) 184

Figs 128–140 128–131, *Carabunia* sp., (128) head, frontal aspect, ♀, (129) right mandible, ♀, (130) base of right forewing, upper surface, ♀, (131) left antenna, inner aspect, ♀; 132, *Kataka mudigerensis* sp. n., base of right forewing, upper surface, ♀; 133, *Cyrtocoryphes viridiceps* Timberlake, apex of right forewing venation, upper surface, ♀; 134–136, *Ruanderoma sankarani* sp. n., (134) right forewing showing pattern of infuscation, ♀, (135) thorax, dorsal aspect, ♀, (136) right mandible, ♀; 137, *Parencyrtomyia niveiclava* Girault, right antenna, outer aspect, ♀; 138, *Trichomasthus* sp., thorax, aspect from left side, ♀; 139, *Rhytidothorax* sp., thorax, aspect from left side, ♀; 140, *Copidosoma* sp., thorax, aspect from left side, ♀.

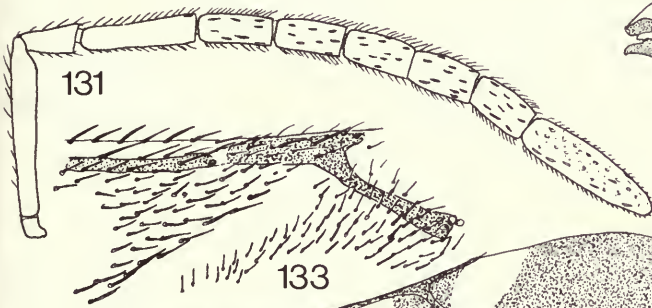
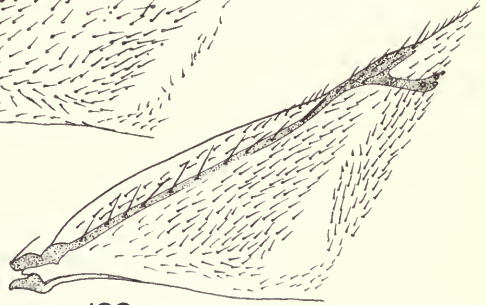
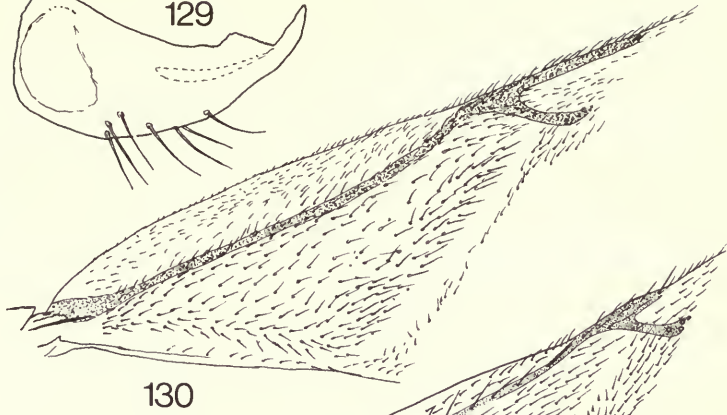
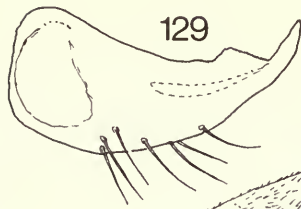
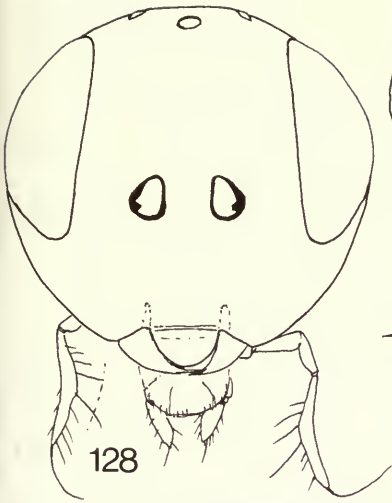

132

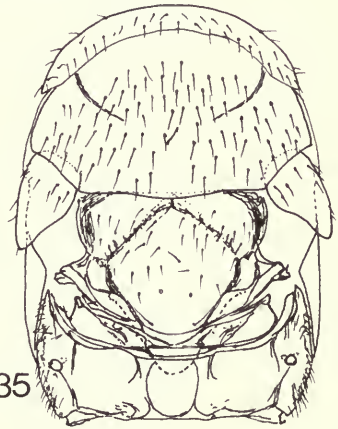
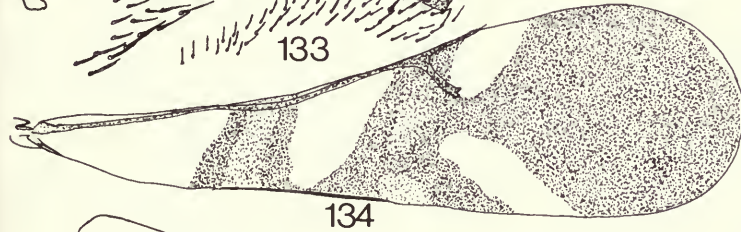

135

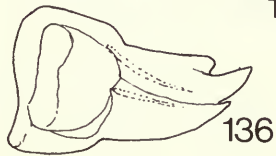

136

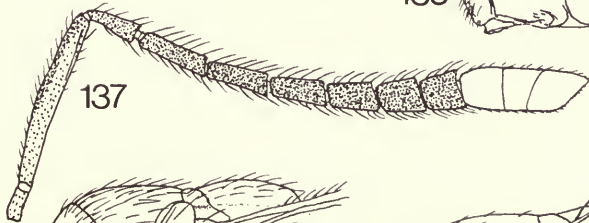

137

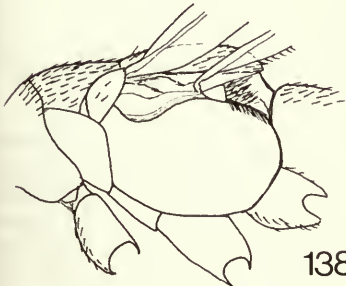

138

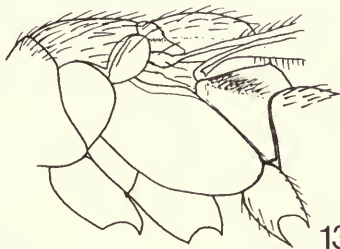

139

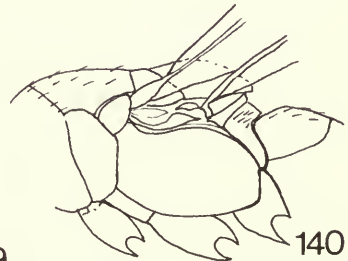

140

-	Submarginal vein of forewing at most slightly broadened apically but without a subapical triangular expansion (Figs 117, 238, 394)	185
184 (183)	Clava three-segmented	TYNDARICHUS (p. 346)
-	Clava entire (Fig. 108)	TYNDARICOPSIS (p. 347)
185 (183)	Clava entire	AUSTRALANUSIA (p. 236)
-	Clava three-segmented	186
186 (185)	Scape hardly longer than broad, much less than one and one-half times as long as broad and only about one and one-half times as long as pedicel (Fig. 110); antennal toruli a little more than twice their own lengths from mouth margin; mandible with four teeth (Fig. 111); gaster unicolorous, dark, not yellow	
		NEOCLADELLA (p. 305)
-	Scape more than one and one-half times as long as broad and at least about twice as long as pedicel; antennal toruli not more than twice their own lengths from mouth margin; mandibles with three teeth or one or two teeth and a truncation, or if with four teeth (Fig. 112) then base of gaster is yellow contrasting with the dark remainder	187
187 (186)	Mesopleurum posteriorly enlarged so that it nearly touches base of gaster, when thorax viewed from side it clearly separates propodeum and metapleurum from hind coxa (as in Figs 101, 138, 177); base of gaster yellowish; mandible with four teeth (Fig. 112)	ECTOPIOGNATHA (p. 267)
-	Mesopleurum not so enlarged and clearly separated from base of gaster by metapleurum together with propodeum which are at least narrowly in contact with hind coxa (as in Figs 102, 139, 140), or if mesopleurum enlarged as in alternate, then gaster is unicolorous and dark; mandible with three teeth or one or two teeth and a truncation or rarely with four	188
188 (187)	Forewing with postmarginal vein clearly much longer than stigmal . . .	AGENIASPIS (p. 226)
-	Forewing with postmarginal vein not or hardly longer than stigmal	189
189 (188)	Antennal toruli situated relatively high on head, their lower margins level with, or above, lower eye margins when head viewed from front (Fig. 113); eye not distinctly hairy	190
-	Antennal toruli relatively lower, their lower margins clearly below the lowest eye margins when head viewed from front; eye often very hairy	192
190 (189)	Thorax dorsally convex; antennal scape not longer than malar space	GAHANIELLA (p. 278)
-	Thorax dorsally fairly flat; antennal scape at least a little longer than malar space	191
191 (190)	Antennal clava with apex pointed, its dorsal margin strongly curved whilst its ventral margin is more or less straight, first funicle segment clearly shorter than pedicel and subsequent segments becoming broader and larger towards apex of antenna; mandible with three sharp teeth	MAYRIDIA (p. 295)
-	Antennal clava apically rounded and more or less cylindrical, funicle segments subequal in length and usually also in breadth to pedicel and not distinctly widening towards apex of antenna (Fig. 114); mandible with one or two teeth and a truncation	THOMSONISCA (p. 343)
192 (189)	Scutellum and mesoscutum flat, at least scutellum matt and not strongly metallic, often with relatively deep reticulate sculpture; eye not distinctly hairy	193
-	Scutellum and mesoscutum clearly convex, or if flat then either both are strongly metallic or the eye is conspicuously hairy	195
193 (192)	Mandible with four teeth (Fig. 116)	ADELENCYRTUS (p. 223)

Figs 141–151 141, *Saprencyrtus casuarinae* (Girault), right forewing showing pattern of infuscation (from card-mounted specimen), ♀; 142, *Copidosoma* sp., apex of right forewing venation, upper surface, ♀; 143, 144, *Tachinaephagus* sp., (143) apex of left forewing venation, upper surface, ♀, (144) right mandible, ♀; 145, *Manicnemus indicus* (Mani & Saraswat), right forewing showing pattern of infuscation, ♀; 146, *Homalotylus* sp., right antenna, outer aspect, ♀; 147, *Mahencyrtus comara* (Walker) (extra-limital species), base of left forewing, upper surface, ♀; 148, *Adekittopus gordhi* sp. n., base of right forewing, upper surface, ♀; 149, *Cheiloneurella* sp., thorax, dorsal aspect, ♀; 150, *Eotopus beneficus* (Shafee), base of right forewing, upper surface, ♀; 151, *Paraclausenia herbicola* Hayat, base of right forewing, upper surface, ♀.

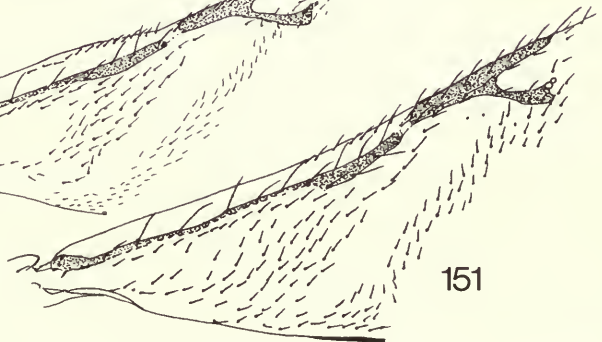
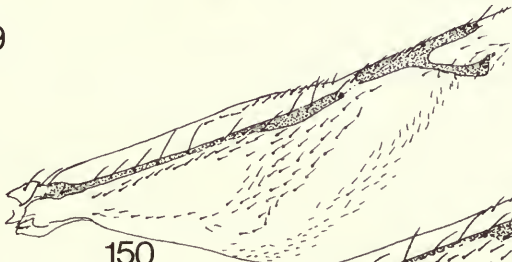
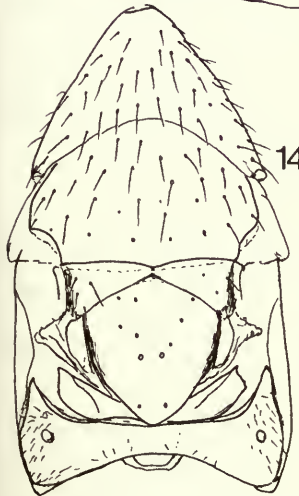
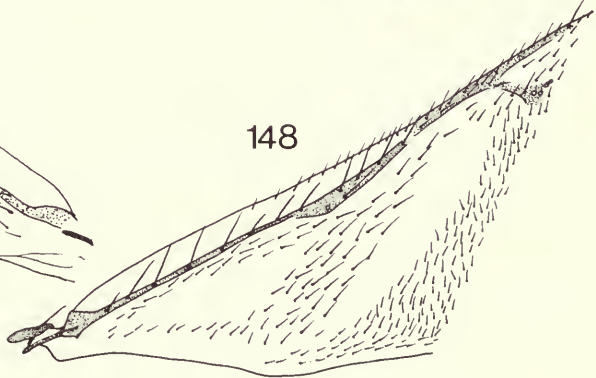
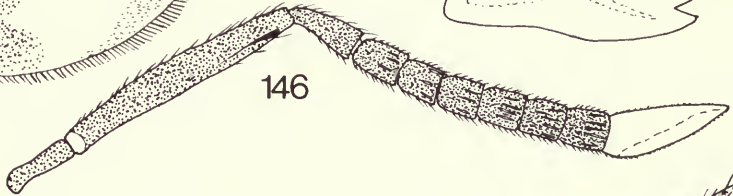
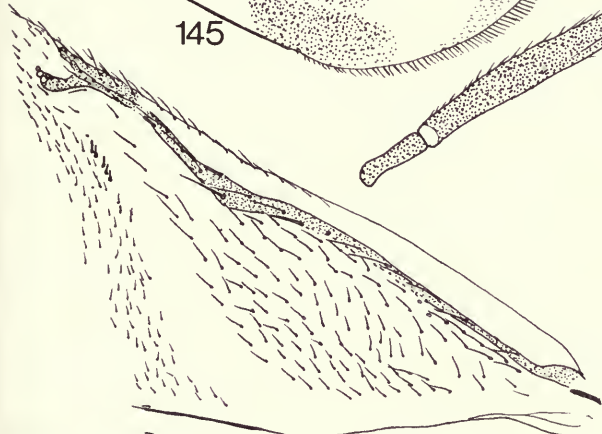
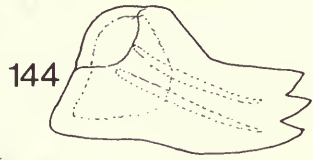
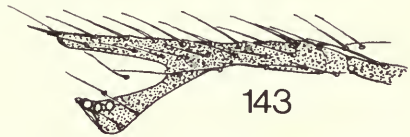
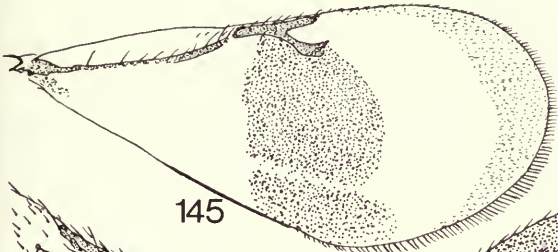
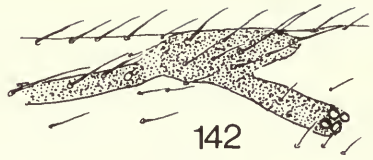

–	Mandible with one or two teeth and a truncation (Fig. 115)	194
194 (193)	Forewing with linea calva closed or interrupted on dorsal surface of wing (Fig. 117)	<i>COCCIDENCYRTUS</i> (p. 253)
–	Forewing with linea calva neither closed nor interrupted	<i>EPITETRALOPHIDEA</i> (p. 273)
195 (192)	Both mesoscutum and scutellum very convex and dull, not shiny, with fine striate-reticulate or punctate-reticulate sculpture	<i>PARABLATTICIDA</i> (p. 314)
–	Mesoscutum and scutellum flat or only slightly convex and usually at least a little shiny; sculpture shallow reticulate, or if punctate-reticulate then dorsum of thorax distinctly metallic blue, green or purple	196
196 (195)	Exserted part of ovipositor at least as long as one-quarter length of gaster	197
–	Ovipositor not or hardly exserted	200
197 (196)	Exserted part of ovipositor slightly but distinctly downcurved; mandible with two teeth and a truncation	<i>EPIBLATTICIDA</i> (p. 272)
–	Exserted part of ovipositor straight; mandible with three acute teeth	198
198 (197)	Exserted part of ovipositor at least about two-thirds as long as gaster	<i>NEZARHOPALUS</i> (p. 307)
–	Exserted part of ovipositor less than half as long as gaster	199
199 (198)	Hypopygium extending past apex of gaster so that it is clearly visible in dorsal view (Fig. 125)	<i>COCCIDICTONUS</i> (p. 254)
–	Hypopygium not extending past apex of gaster and not visible in dorsal view	<i>TELETEREBRATUS</i> (p. 341)
200 (196)	Eye with conspicuous, long, dark setae	201
–	Eye more or less naked	202
201 (200)	First funicle segment anelliform and clearly much shorter than second which is subequal to the remaining funicle segments, all of which are slightly transverse (Fig. 120); scutellum with longitudinally reticulate sculpture which is clearly much deeper than the more regularly reticulate sculpture of mesoscutum	<i>PHAULOENCYRTUS</i> (p. 323)
–	First funicle segment not contrasting with remaining segments as in alternate, the funicle segments usually enlarging distally; sculpture of scutellum not deeper than that of mesoscutum, usually more shallow	<i>EXORISTOBIA</i> (p. 277)
202 (200)	Clava strongly obliquely truncate and clearly longer than funicle	203
–	Clava without a strong oblique truncation and shorter than funicle	204
203 (202)	Head and mesoscutum with punctate-reticulate sculpture similar to that of scutellum	<i>BAEOANUSIA</i> (p. 241)
–	Head and mesoscutum with shallow irregular reticulate sculpture, almost smooth and clearly much shallower than that on scutellum	<i>MESANUSIA</i> (p. 296)
204 (202)	Mandible with one or two teeth and a truncation (Figs 121, 122); forewing with marginal vein punctiform or rarely longer than broad	<i>PSYLLAEPHAGUS</i> (p. 330)
–	Mandible with three acute teeth (Fig. 76); forewing with marginal vein always longer than broad	<i>AENASIELLA</i> (p. 224)
205 (14)	Body foliaceously dorso-ventrally flattened; pronotum longitudinally divided in middle (Fig. 124)	206
–	Body not or hardly dorso-ventrally flattened; pronotum entire	207
206 (205)	Clava three-segmented; marginal fringe of forewing about one-eighth as long as maximum width of wing	<i>PLATYRHOPUS</i> (p. 325)
–	Clava entire; marginal fringe of forewing at most a little longer than one-fifth maximum width of wing	<i>ASITUS</i> (p. 236)
207 (205)	Forewing with a naked line connecting apex of stigmal vein to apex of postmarginal vein and anterior wing margin (Fig. 126)	<i>PENTELICUS</i> (p. 322)
–	Setation at apex of forewing venation normal, naked line not present	208
208 (207)	Either not all funicle segments longer than broad or forewing with postmarginal vein longer than stigmal	209
–	All funicle segments longer than broad and forewing with postmarginal vein not longer than stigmal	220
209 (208)	Head, dorsum of thorax and mesopleurum with distinctive deep punctate sculpture; forewing with postmarginal vein at least a little longer than stigmal; scutellum never with an apical flange	<i>BLASTOTHRIX</i> (p. 242)

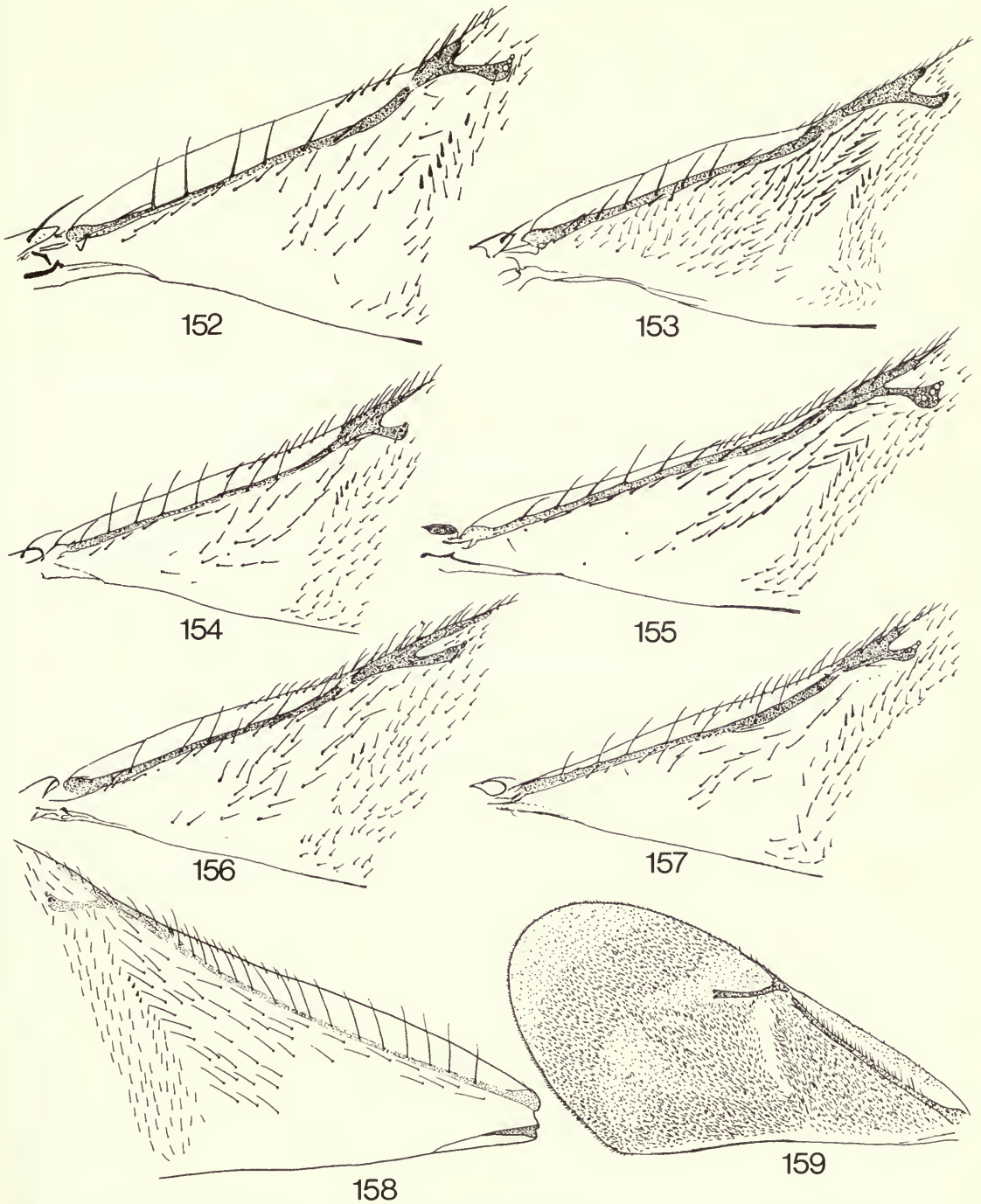

Figs 152–159 152, *Ooencyrtus* sp., base of right forewing, upper surface, ♀; 153, *Trichomasthus* sp., base of right forewing, upper surface, ♀; 154, *Hengata spinosa* sp. n., base of right forewing, upper surface, ♀; 155, *Cheiloneurella* sp., base of right forewing, upper surface, ♀; 156, *Ethoris dahmsi* sp. n., base of right forewing, upper surface, ♀; 157, *Protyndarichooides* sp., base of right forewing, upper surface, ♀; 158, *Diasula glabriscutellum* (Girault), base of left forewing, upper surface (from card-mounted specimen), ♀; 159, *Mashhoodia indica* Shafee, left forewing showing pattern of light and dark setae, ♀.

- Head and at least mesoscutum and mesopleurum with shallow reticulate sculpture and occasionally relatively deep piliferous punctures, but never, except on scutellum, with punctate sculpture, or if so then scutellum has a distinct apical flange; forewing with postmarginal vein usually not longer than stigmal, although occasionally longer 210
- 210 (209) Frontoververtex relatively narrow, at narrowest point not more than one-sixth head width **NEODISCOIDES** (p. 306)
- Frontoververtex broader, at narrowest point at least one-quarter head width 211
- 211 (210) Apex of scutellum produced in a short thin flange; forewing with postmarginal vein more than one and one-half times as long as stigmal; occipital margin very sharp almost to base of mandible **ERICYDNUS** (p. 274)
- Apex of scutellum without an apical flange; forewing with postmarginal vein less than one and one-half times as long as stigmal; occipital margin rounded or sharp but not as extensively sharp as in alternate 212
- 212 (211) Dorsum of thorax strongly convex, mesoscutum and scutellum dull with at least the scutellum and often mesoscutum with fine longitudinally striate sculpture; forewing with postmarginal vein as long as or longer than stigmal
PARABLATTICIDA (p. 314)
- Dorsum of thorax moderately flat, not strongly convex, neither mesoscutum nor scutellum with longitudinally striate sculpture and often quite shiny; forewing with postmarginal vein occasionally as long as or longer than stigmal but usually a little shorter 213
- 213 (212) Eye relatively small and clearly not reaching occipital margin which is more or less rounded, the greatest length of eye not more than minimum width of frontoververtex 214
- Eye larger, at least slightly longer than minimum width of frontoververtex and more or less reaching occipital margin which is sharp 215
- 214 (213) Antennal toruli close to mouth margin, separated from it by less than half their own lengths (Figs 442, 443); head prognathous, in profile more or less gradually and evenly curved anteriorly and not triangular; mandible with two or three sharp teeth (Fig. 443) **ZAOMMOENCYRTUS** (p. 349)
- Antennal toruli more than their own lengths from mouth margin; head opisthognathous and in side view appearing triangular being acutely angled inwards at top of antennal scrobes; mandible with one or two teeth and a broad truncation **HUNTERELLUS** (p. 288)
- 215 (213) Forewing with filum spinosum directed towards junction of marginal and submarginal veins and thus clearly converging with the line of setae on the proximal margin of the linea calva (Fig. 127) **CERCHYSIELLA** (p. 246)
- Forewing with filum spinosum absent or directed towards junction of stigmal and marginal veins and thus more or less parallel with line of setae on proximal margin of linea calva 216
- 216 (215) Propodeum relatively long, medially at least about one-fifth length of scutellum and with some carinae (Fig. 99); scutellum usually with an apical carina (although often very fine); gonostyli always hidden externally **RHYTIDOTHORAX** (p. 333)

Figs 160–175 160, 161, *Adektitopus gordhi* sp. n., (160) sculpture in centre of mesoscutum (area approx. 0.1 mm square), ♀, (161) sculpture in centre of scutellum (area approx. 0.1 mm square), ♀; 162, *Anomalicornia* sp., apex of right forewing venation, upper surface, ♀; 163, *Leptomastidea aurantiaca* Mercet (extra-limital species), apex of right forewing venation, upper surface, ♀; 164, *Leptomastix nigrocoxalis* Compere, apex of right forewing venation, upper surface, ♀; 165, *Bacalusa fuscipennis* sp. n., base of right forewing, upper surface, ♀; 166, *Apoleptomastix spoliata* Kerrich, right antenna, inner aspect, ♀; 167, *Alamella flava* Agarwal, right antenna, outer aspect, ♀; 168, *Leptomastix dactylopii* Howard, left antenna, outer aspect, ♀; 169, *Anomalencyrtus longicornis* Hayat & Verma, left antenna, inner aspect, ♀; 170, 171, *Paratetracnemoidea malenoti* (Mercet) (extra-limital species), (170) right antenna, outer aspect, ♀, (171) apex of left forewing venation, upper surface, ♀; 172, *Heterococtidoxenus schlehtendali* (Mayr), apex of right forewing venation, upper surface, ♀; 173, *Bacalusa tachikawai* (Shafee, Alam & Agarwal), right antenna, outer aspect, ♀; 174, *Bacalusa fuscipennis* sp. n., right antenna, outer aspect, ♀; 175, *Doliphoceras nigricans* (Perkins), right antenna, outer aspect, ♀.

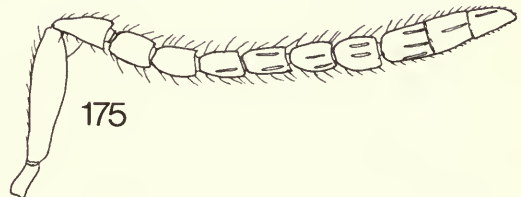
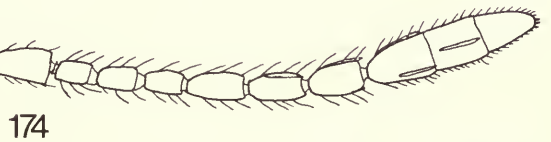
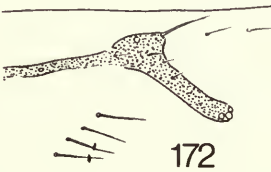
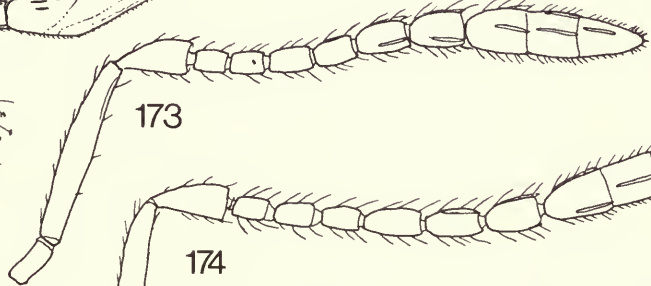
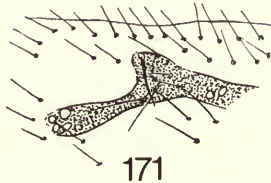
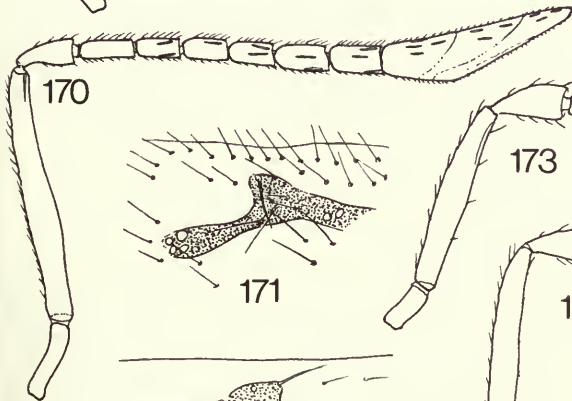
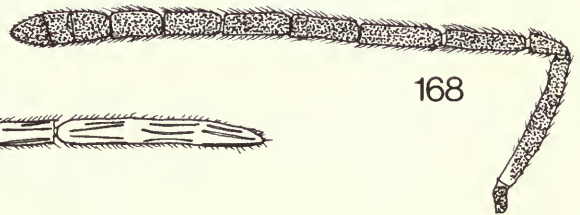
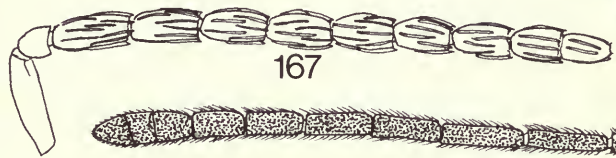
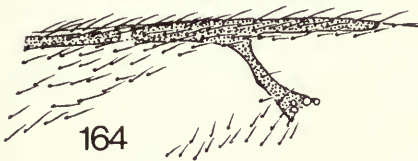
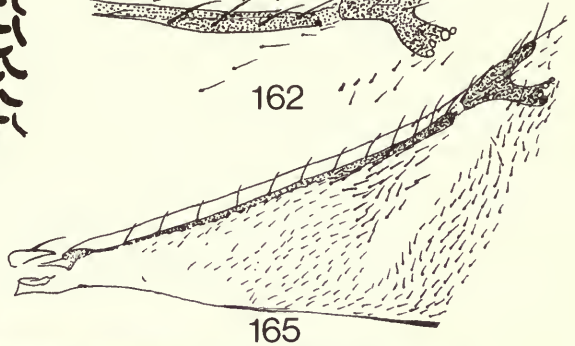
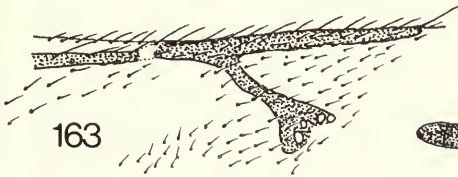
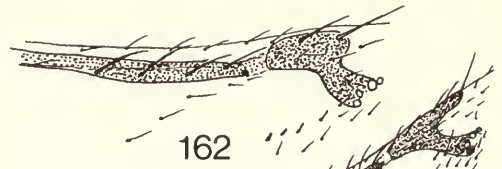
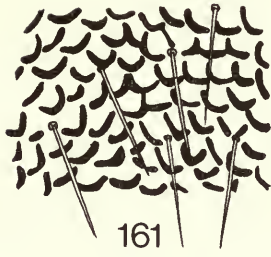
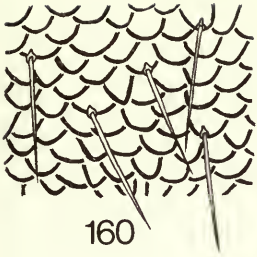

-	Propodeum medially very short, without any carinae medially and medially not more than one-eighth as long as scutellum which is apically without a carina (Fig. 100); gonostyli often clearly visible externally	217
217 (216)	Postmarginal vein of forewing not longer than stigmal	218
-	Forewing with postmarginal vein longer than stigmal	219
218 (217)	Mandible with three acute teeth (Figs 118, 119); tegula always dark; legs usually extensively dark and never marked with pale yellow	COELOPENECYRTUS (p. 255)
-	Mandible with one or two teeth and a truncation (Figs 121, 122); tegula and legs often at least partly pale yellow	PSYLLAEPHAGUS (p. 330)
219 (217)	Mandible with three acute teeth (Fig. 123); exerted part of ovipositor at least one-third as long as gaster	RHOPALENCYRTOIDEA (p. 332)
-	Mandible bidentate; ovipositor not or hardly exerted	220
220 (208, 219)	Head and dorsum of thorax with fine punctate-reticulate or vermiculate sculpture which gives these a silky appearance	ANAGYRUS (p. 229)
-	At least head and mesoscutum with shallow reticulate sculpture which is not silky in appearance and which is more distinctly shiny	221
221 (220)	Frontovertex at narrowest point at least half head width; antennal flagellum unicolorous; sculpture of scutellum almost same as that on head and mesoscutum	DOLIPHOCERAS (p. 266)
-	Frontovertex at narrowest point much less than half head width; antennal flagellum usually with at least one white segment contrasting with dark brown segments; scutellum with fine punctate-reticulate sculpture which contrasts strongly with shallower sculpture of mesoscutum	EPIDINOCARSIS (p. 272)
222 (18)	Eye nearly touching base of mandible so that malar space is not more than one-fifth length of eye; ovipositor distinctly exerted, the exerted part at least about one-third as long as gaster	HEXENCYRTUS (p. 286)
-	Eye clearly separated from base of mandible, malar space at least nearly one-half as long as eye; ovipositor not exerted	223
223 (222)	Occipital margin rounded; forewing with postmarginal vein shorter than stigmal (Fig. 132)	KATAKA (p. 290)
-	Occipital margin sharp; forewing with postmarginal vein longer than stigmal (Fig. 130)	224
224 (223)	Clava three-segmented; mandible broad and truncate, without teeth; eye separated from occipital margin by at least about twice diameter of a facet	PRIONOMASTIX (p. 325)
-	Clava entire (Fig. 131); mandible with one long, acute tooth (Fig. 129); eye separated from occipital margin by not more than diameter of a facet	CARABUNIA (p. 244)
225 (19)	Forewing with linea calva interrupted or more or less closed on dorsal surface by several lines of setae towards posterior margin	226
-	Forewing with linea calva neither interrupted nor closed on dorsal surface, except perhaps by one or two setae	231
226 (225)	Forewing with postmarginal vein very short or absent, much shorter than stigmal (Fig. 133)	227

Figs 176–192 176, *Cerchysius* sp., aspect from left side, ♀; 177, *Ooencyrtus* sp., thorax, aspect from left side, ♀; 178, *Paraenasomyia orro* Girault, right mandible, ♀; 179, *Australia minuta* Girault, antenna, ♀; 180, *Paraschedius* sp., apex of right forewing venation, upper surface (discal setae omitted), ♀; 181, *Ooencyrtus pacificus* Waterston, apex of left forewing venation, upper surface, ♀; 182, *Ooencyrtus batocerae* Ferrière, apex of right forewing venation, upper surface, ♀; 183, *Copidosoma* sp., apex of left forewing venation, upper surface, ♀; 184, 185, *Tachardiaephagus tachardiae* Howard, (184) head frontal aspect, ♀, (185) head, dorsal aspect, ♀; 186, *Syrphophagus hofferi* (Hayat), base of left forewing, upper surface, ♀; 187, *Ethoris dahmsi* sp. n., apex of right forewing venation, upper surface, ♀; 188, *Lemnaisia ambigua* (Nees), left mandible, ♀; 189, *Coccidencyrtus bicolor* (Girault), right mandible, ♀; 190, *Papuna nemis* sp. n., apex of right forewing venation, upper surface (discal setae omitted), ♀; 191, *Cowperia indica* (Kerrich), apex of right forewing venation, upper surface, ♀; 192, *Echthrogonatus nigricornis* (Hayat), base of right forewing, upper surface, ♀.

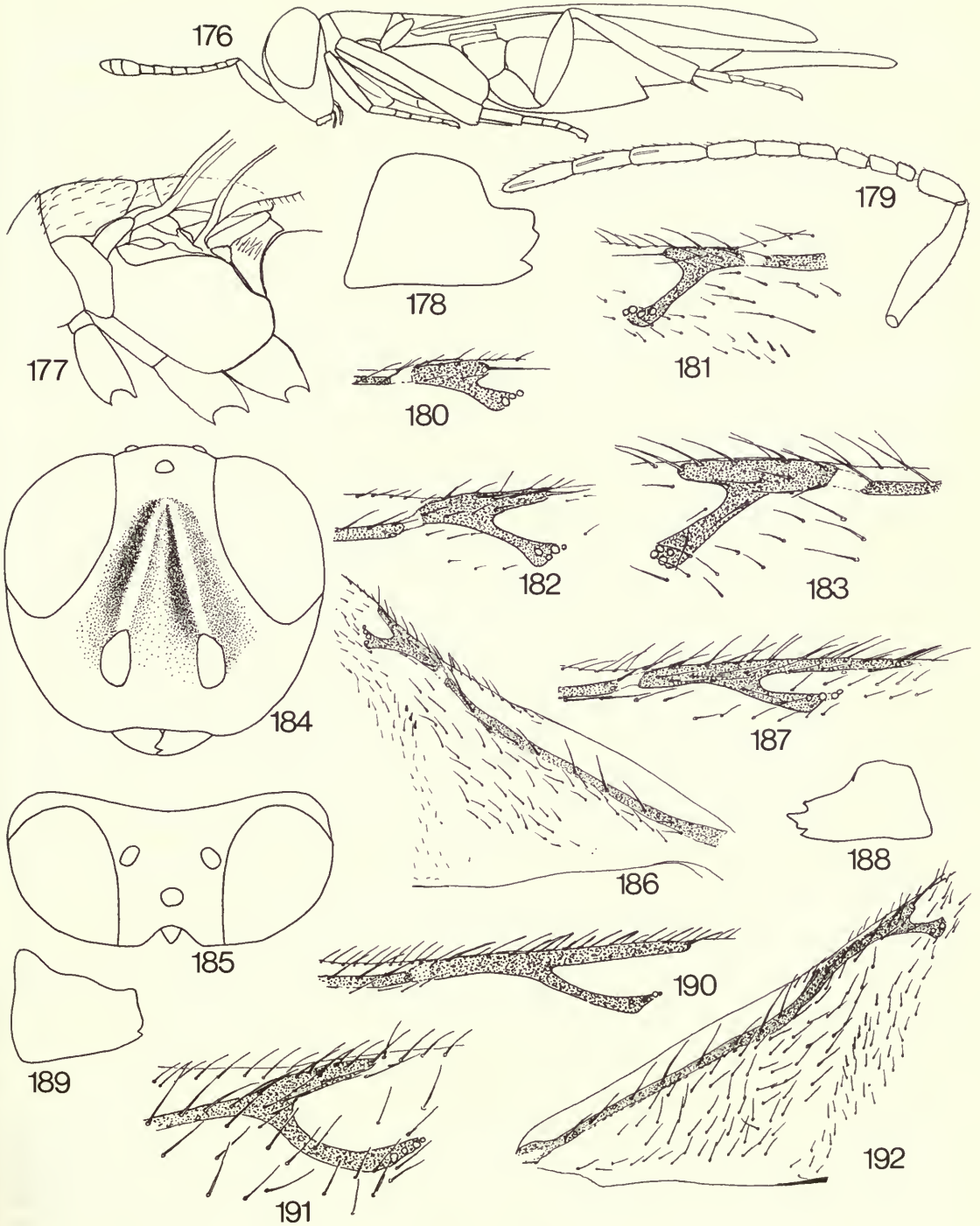

- Forewing with postmarginal vein nearly as long as or longer than stigmal (Figs 134, 164) 228
- 227 (226) Scutellum without dense white setae arranged in a more or less distinct pattern; infuscation of forewing restricted to a broad band below apical half of venation; head and dorsum of thorax metallic green or blue . . . **CYRTOCORYPHES** (p. 263)
- Scutellum with a pattern of dense silvery-white setae; forewing with infuscation pale but more or less evenly distributed; head and thorax black and dull but with some slight brassy reflections **PARANATHRIX** (p. 317)
- 228 (226) Notaular lines present in anterior part of mesoscutum (Fig. 135); mandible with three acute teeth (Fig. 136) **RUANDEROMA** (p. 334)
- Notaular lines absent; mandible with two acute teeth 229
- 229 (228) Forewing brown with hyaline bands or spots (similar to Fig. 135) **CALLIPTEROMA** (p. 244)
- Forewing hyaline with one or more pale brown longitudinal streaks or generally suffused pale brown 230
- 230 (229) Forewing with one or more pale brown longitudinal streaks; antennal flagellum unicolorous **LEPTOMASTIX** (p. 293)
- Forewing generally suffused pale brown distad of bend of submarginal vein; antennal flagellum with contrasting dark and pale segments **ANAGYRUS** (p. 229)
- 231 (225) Clava apically with a slight but distinct oblique truncation and outer suture converging with inner (Fig. 137) 232
- Clava apically transversely truncate or rounded so that the outer suture is more or less parallel with inner 233
- 232 (231) Antennal flagellum unicolorous and brown; body dark and moderately to strongly lustrous (latter especially on face); mandible with one tooth and a broad truncation [*Cerchysius*] **australensis** Ashmead (p. 352)
- Clava white contrasting with the brown funicle; body orange or brown, not lustrous; mandible with three acute teeth **PARENCYRTOMYIA** (p. 320)
- 233 (231) Mesopleurum not enlarged posteriorly and not in contact with basal segment of gaster so that when thorax viewed from side metapleurum and propodeum together are broadly (very rarely narrowly) in contact with hind coxa (Figs 139, 140); mandible with one, two or three sharp teeth, never with a truncation; hypopygium often reaching apex of gaster 234
- Mesopleurum enlarged posteriorly and touching or almost touching basal segment of gaster so that when thorax viewed from side it separates metapleurum and propodeum from hind coxa (Fig. 138) or these are only very narrowly meeting; mandible with one or two teeth and a truncation; hypopygium never extending more than three-quarters along gaster 237
- 234 (233) Apex of hypopygium not reaching more than about one-third along gaster; forewing with a complete hyaline fascia distad of venation (Fig. 141) **SAPRENCYRTUS** (p. 336)
- Apex of hypopygium reaching to at least about two-thirds along gaster, often to apex; forewing without a complete hyaline fascia distad of venation 235
- 235 (234) Antennal toruli separated from mouth margin by less than half their own lengths; forewing with sensillae at apex of stigmal vein arranged symmetrically in a square, uncus absent (Fig. 142) **COPIDOSOMA** (p. 258)
- Antennal toruli separated from mouth margin by at least only a little less than their own lengths; forewing with sensillae at apex of stigmal vein not arranged in a square, uncus present (Fig. 143) 236

Figs 193–201 193, *Copidosomyia ambiguus* (Subba Rao), right antenna, outer aspect showing sensory truncate surface at apex of clava, ♀; 194, *Mashhoodiella echthromorpha* Hayat, antenna, ♀; 195, 196, *Sakencyrtus* sp., (195) thorax, dorsal aspect, ♀, (196) right forewing, upper surface, ♀; 197, *Pseudococcobius terryi* (Fullaway), base of right forewing, upper surface, ♀; 198, *Homalotylus* sp., base of right forewing, upper surface, ♀; 199, *Aphycus* sp., base of right forewing, upper surface, ♀; 200, 201, *Isodromus axillaris* Timberlake, (200) right antenna, outer aspect, ♀, (201) base of right forewing, upper surface, ♀.

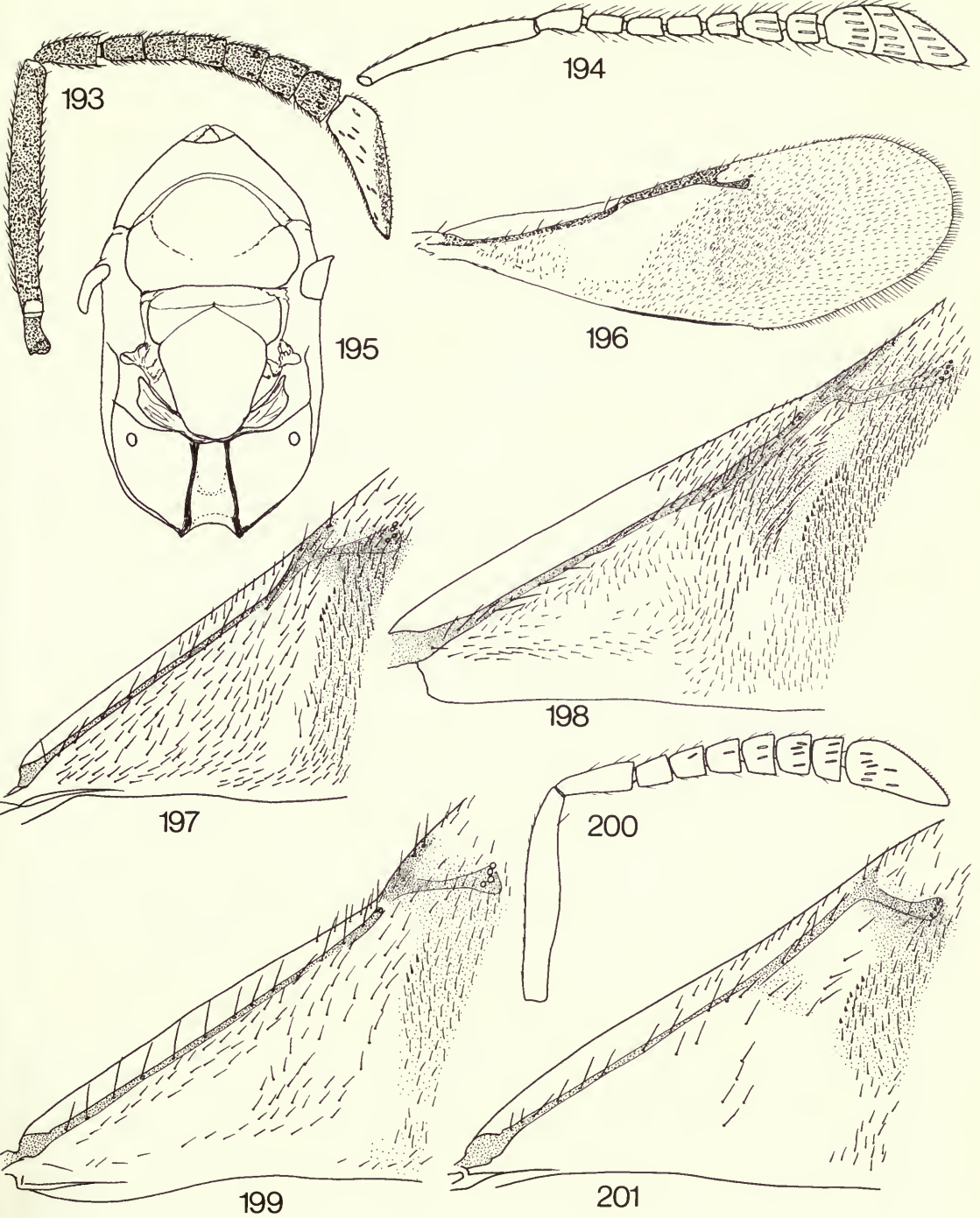

- 236 (235) Ovipositor at least slightly exerted so that gonostyli are externally visible; mandible always with three sharp teeth (Fig. 144) *TACHINAEFHAGUS* (p. 340)
 – Ovipositor never exerted and gonostyli never visible externally; mandible usually with one or two sharp teeth and only very rarely with three
RHYTIDOTHORAX (p. 333)
- 237 (233) Scutellum with punctate-reticulate sculpture which is conspicuously deeper than the shallow reticulate sculpture of mesoscutum; infuscation of forewing pale and inconspicuous and represented only by a subapical band *TRICHOMASTHUS* (p. 346)
 – Scutellum with shallow reticulate sculpture which is not deeper than that of mesoscutum and apically distinctly shallower; infuscation of forewing more extensive, usually covering apical two-thirds of wing but often with one or two hyaline bands distad of venation *MICROTERTYS* (p. 299)
- 238 (19) Notaular lines present in at least anterior one-third of mesoscutum 239
 – Notaular lines absent 243
- 239 (238) Notaular lines complete (Fig. 6); clava with an oblique apical truncation (Fig. 146) *HOMALOTYLUS* (p. 287)
 – Notaular lines not reaching more than half way across mesoscutum; clava apically rounded 240
- 240 (239) Head and thorax orange-red, not metallic *BACALUSA* (p. 239)
 – Head and thorax at least partly metallic 241
- 241 (240) Head and thorax with several white, yellow and orange areas
ECHTHROBACCELLA (p. 267)
 – Head and thorax entirely dark and metallic without any pale areas 242
- 242 (241) Forewing with postmarginal vein longer than stigmal (Fig. 148) *ADEKTTTOPUS* (p. 221)
 – Forewing with postmarginal vein shorter than stigmal (Fig. 145) *MANICNEMUS* (p. 294)
- 243 (238) Hypopygium reaching apex of gaster; ovipositor not exerted; mandible with two acute teeth (possibly three in *Ameniscocephalus*) 244
 – Hypopygium not reaching more than four-fifths along gaster, or if so then ovipositor is exerted and exerted part at least one-third as long as gaster; mandible with one or two teeth and a truncation or three or four teeth 246
- 244 (243) Head lenticular, in side view about three times as long as wide; forewing evenly infuscate without any hyaline areas *AMENISCOCEPHALUS* (p. 227)
 – Head not lenticular, in side view not or hardly more than twice as long as wide; forewing not evenly infuscate and with hyaline areas 245
- 245 (244) Forewing with postmarginal vein at least as long as stigmal, infuscation usually restricted to apex or to two narrow fasciae *LEPTOMASTIDEA* (p. 292)
 – Forewing with postmarginal vein clearly shorter than stigmal, infuscation at least a wide band across wing from apical one-third of venation and often another at apex (Fig. 79) *PARECTROMOIDEA* (p. 319)
- 246 (243) Head and thorax (excluding legs and antennae) dark and metallic 247
 – Head and thorax (excluding legs and antennae) not completely dark and metallic, at least partly pale 256
- 247 (246) Head triangular in profile, strongly inflexed at top of antennal scrobes (as in Fig. 72); mandible with four teeth (Fig. 116) *ADELENCYRTUS* (p. 223)
 – Head in profile more or less evenly rounded anteriorly, not strongly inflexed at top of antennal scrobes; mandible with one or two teeth and a truncation or three teeth 248

Figs 202–212 202, 203, *Agarwalencyrtus citri* (Agarwal), (202) right antenna, outer aspect showing sensory truncate surface on apex of clava, ♀, (203) thorax, dorsal aspect showing distribution of setae (left side) and sculpture (right side), ♀; 204, *Copidosoma* sp., right antenna, outer aspect showing sensory truncate surface at apex of clava, ♀; 205, *Proleuroceroides* sp., left antenna, inner aspect showing pattern of infuscation, ♀; 206, 207, *Parechthrodryinus clavicornis* Cameron, (206) scutellum and propodeum, dorsal aspect, ♀, (207) apex of right forewing venation, upper surface, ♀; 208, 209, *Astymachus japonicus* Howard, (208) right antenna, outer aspect, ♀, (209) head, thorax and gaster, dorsal aspect, ♀; 210, *Mahencyrtus comara* (Walker) (extra-limital species), scutellum and propodeum, dorsal aspect, ♀; 211, 212, *Taftia siassetiae* Gahan, (211) left antenna, inner aspect, ♀, (212) right forewing, upper surface, ♀.

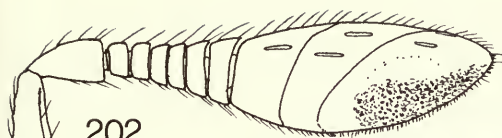

202

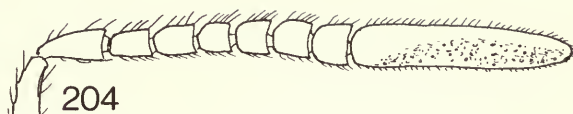

204

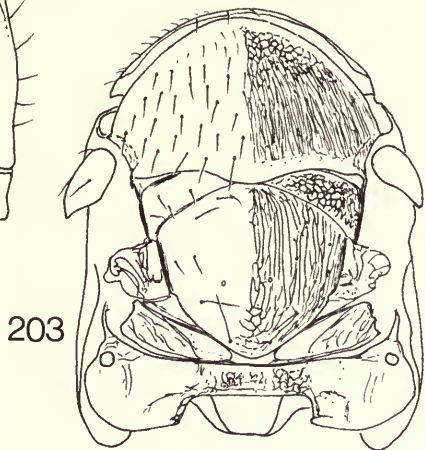

203

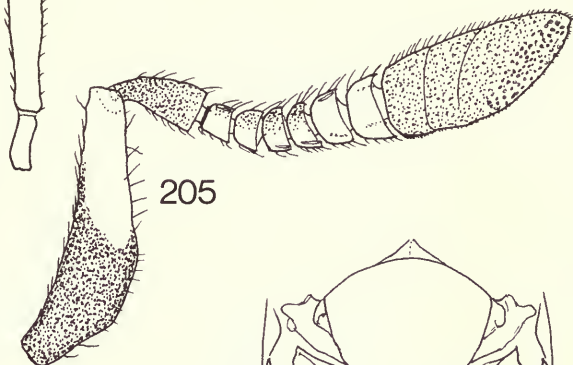

205

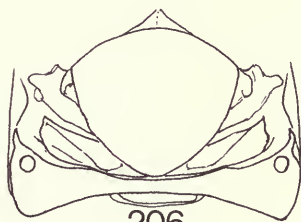

206

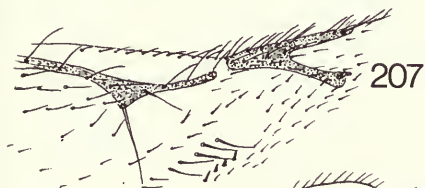

207



210

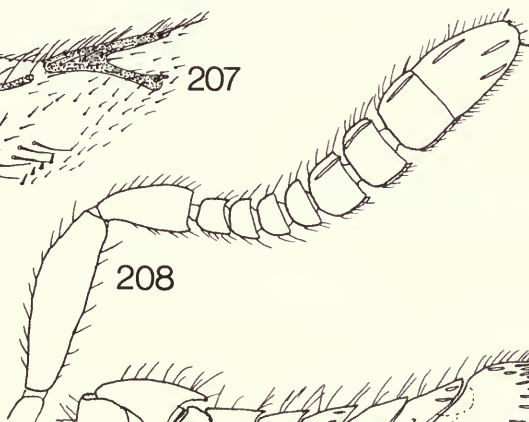

208



209

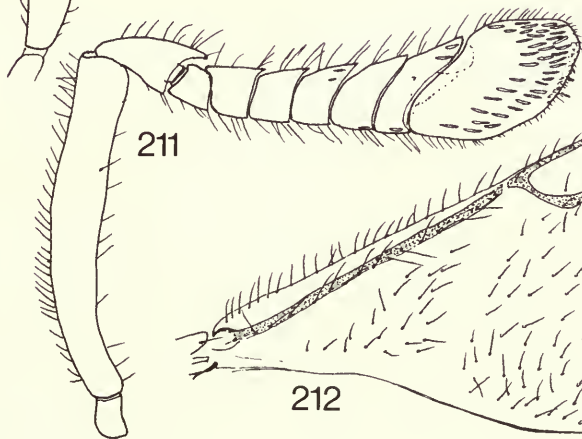

211



212

248 (247)	Postmarginal vein of forewing longer than stigmal	ENCYRTOIDEA (p. 268)
–	Postmarginal vein of forewing not longer than stigmal	249
249 (248)	Posterior margin of mesoscutum strongly projecting backwards so that when thorax is in normal resting position it projects above axillae and separates them by at least the length of the visible part of the axilla (Fig. 44)	XENOENCYRTUS (p. 348)
–	Posterior margin of mesoscutum hardly projecting above axillae so that they appear to meet medially or almost so when thorax is in normal resting position (as in Fig. 42)	250
250 (249)	Forewing with sensillae at apex of stigmal vein arranged symmetrically in a square, uncus absent (Fig. 142)	COPIDOSOMA (p. 257)
–	Forewing with sensillae at apex of stigmal vein not arranged in a square, uncus present and distinct (Figs 147, 148, 150–152)	251
251 (250)	Forewing with stigmal vein longer than marginal	252
–	Forewing with stigmal vein not longer than marginal	253
252 (251)	Mandible with one or two teeth and a truncation (Figs 121, 122); forewing with marginal vein not more than twice as long as broad	PSYLLAEPHAGUS (p. 330)
–	Mandible with three acute teeth; forewing with marginal vein at least three times as long as broad	CONCHYNILLA (p. 256)
253 (251)	Infuscation of forewing restricted to a median longitudinal wedge-shaped streak from apex of wing to about level with apex of venation, submarginal vein with parastigma slightly to strongly broadened, this broadening often triangular and indicated by a single erect seta (as in Fig. 147)	MAHENCYRTUS (p. 294)
–	Infuscation of forewing more extensive than in alternate, usually extending from apex of submarginal vein to near apex of wing and enclosing one or two hyaline areas, submarginal vein with parastigma not so distinctly expanded	254
254 (253)	Hypopygium reaching apex of gaster	*PROCHILONEURUS Silvestri (p. 327)
–	Hypopygium not reaching more than two-thirds along gaster	255
255 (254)	Gaster unicolorous, completely dark not white or yellow basally	NEABROLEPOIDEUS (p. 303)
–	Gaster with basal white or yellow ring contrasting with the dark remainder	MESOCALOCERINUS (p. 297)
256 (246)	Clava obliquely truncate, the sutures strongly converging	257
–	Clava apically rounded, the sutures usually parallel or only slightly converging	258
257 (256)	Hypopygium reaching apex of gaster; exerted part of ovipositor at least half as long as gaster	*PROCHILONEURUS Silvestri (p. 327)
–	Hypopygium not reaching more than two-thirds along gaster; ovipositor not or hardly exerted	MASHHOODIELLA (p. 295)
258 (256)	Body almost entirely orange or yellow	259
–	At least dorsum of thorax brown or green	260
259 (258)	Pronotum triangular and conspicuous in dorsal view, at least about as long as mesoscutum (Fig. 149)	CHEILONEURELLA (p. 248)
–	Pronotum strongly transverse and inconspicuous, not more than one-quarter as long as mesoscutum	PARASCHEDIUS (p. 318)

* Not to be confused with *Procheiloneurus* Girault (p. 326)

Figs 213–226 213, *Neocladia* sp., right hind tibia and tarsus, outer aspect, ♀; 214, *Nathismusia southwoodi* sp. n., base of left forewing, upper surface, ♀; 215, 216, *Muluencyrtus nudipennis* sp. n., (215) apex of right forewing venation, upper surface (from card-mounted specimen), ♀, (216) right hind tibia and tarsus, outer aspect (from card-mounted specimen), ♀; 217–219, *Olypusa hirsuta* sp. n., (217) base of right forewing, upper surface, ♀, (218) head, frontal aspect (from card-mounted specimen), ♀, (219) left antenna, outer aspect (from card-mounted specimen), ♀; 220, *Trichomasthus* sp., right antenna, outer aspect, ♀; 221, 222, *Saprencyrtus casuarinae* (Girault), (221) left mandible, ♀, (222) base of right forewing, upper surface (from card-mounted specimen), ♀; 223, *Echthrogonatopus exitiosus* Perkins, right mandible, ♀; 224, *Echthrogonatopus nigricornis* (Hayat), right antenna, inner aspect, ♀; 225, *Ovaloencyrtus fijiensis* sp. n., left mandible, ♀; 226, *Hypergonatopus bifasciatus* (Timberlake), apex of left forewing venation, upper surface, ♀.

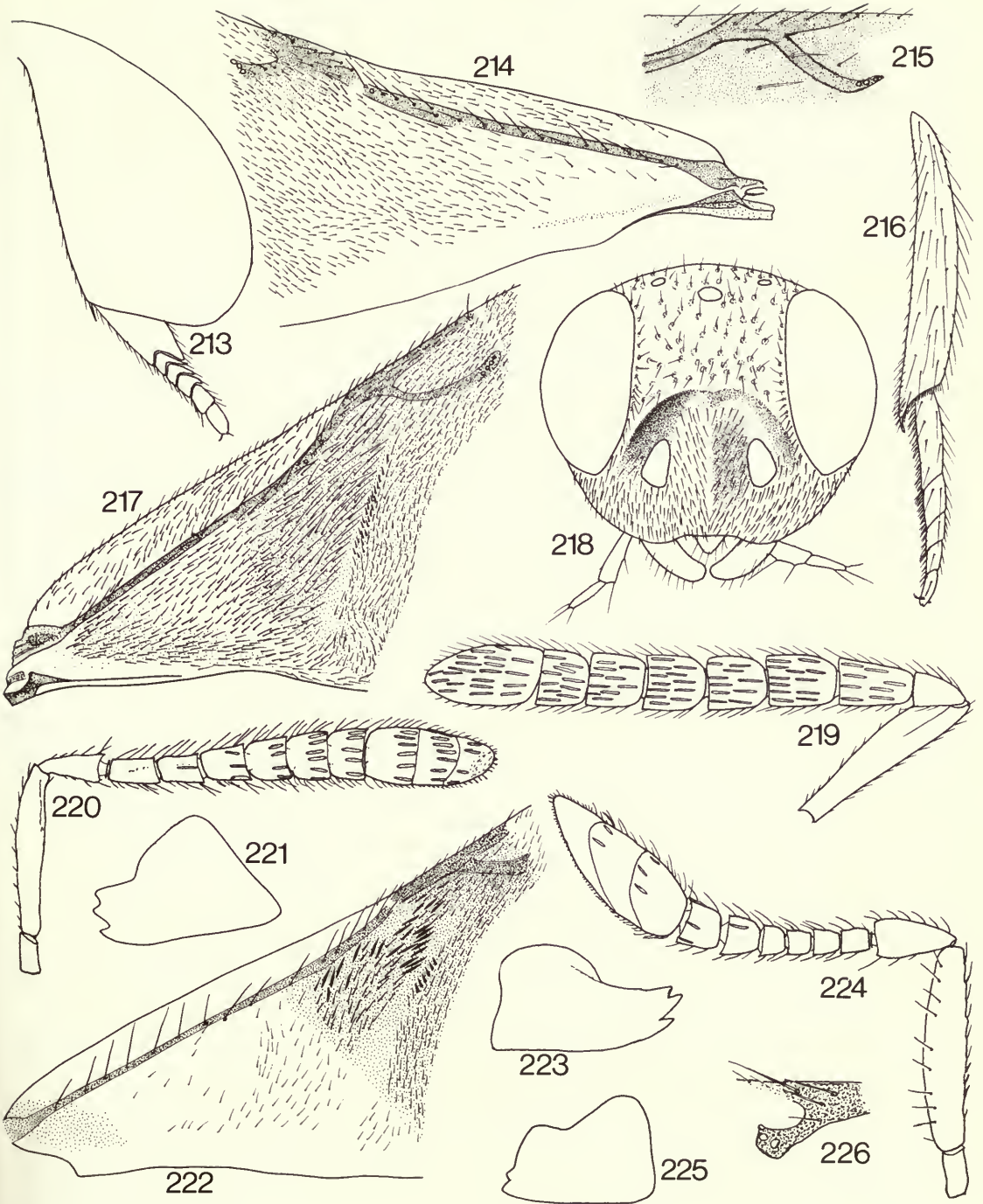

- 260 (258) Forewing with marginal vein punctiform or nearly so, wing with a single large fuscous blotch or broad fascia below marginal vein, hyaline fascia absent
OOENCYRTUS (p. 309)
- Forewing with marginal vein at least twice as long as broad, infuscation of wing more extensive than in alternate and often with at least one hyaline fascia distad of apex of venation 261
- 261 (260) Forewing with a hyaline fascia at apex of venation **MICROTERTYS** (p. 299)
- Forewing without a hyaline fascia at apex of venation **AUSTROMIRA** (p. 238)
- 262 (23) Forewing with postmarginal vein not longer than stigmal (Fig. 150) 263
- Forewing with postmarginal vein at least a little longer than stigmal (Figs 148, 151) 264
- 263 (262) Notaular lines complete; antenna mostly dark brown **CHARITOPUS** (p. 248)
- Notaular lines not reaching more than half way across mesoscutum; antenna completely yellowish orange **EOTOPUS** (p. 269)
- 264 (262) Scutellum with punctate-reticulate sculpture which is clearly much deeper than that of mesoscutum (Figs 160, 161) **ADEKTTITOPUS** (p. 221)
- Scutellum with shallow reticulate sculpture which is not deeper than that of mesoscutum and often quite smooth and shiny 265
- 265 (264) Sculpture of scutellum clearly more shallow than that of mesoscutum, almost smooth; eyes overreaching occipital margin; forewing relatively broad, much less than two and one-half times as long as broad; mandible bidentate
CLAUSENIA (p. 251)
- Sculpture of scutellum about same as that of mesoscutum; eyes not overreaching occipital margin; forewing at least slightly more than two and one-half times as long as broad; mandible with three acute teeth **PARACLUSENIA** (p. 316)
- 266 (21, 23) Forewing with a distinct pattern of dark and light setae (Fig. 159) . **MASHHOODIA** (p. 295)
- Forewing without a pattern of dark and light setae 267
- 267 (266) Head and dorsum of thorax with very fine punctate or vermiculate sculpture which gives a velvety or silky appearance, the sculpture of the mesoscutum not conspicuously different from that on either scutellum or head 268
- Head and dorsum of thorax with reticulate sculpture and not with fine punctate or vermiculate sculpture and not with silky or velvety appearance, or if partly so then at least mesoscutum has distinctly shallower and less fine sculpture than either head or scutellum 269
- 268 (267) Forewing with postmarginal vein at least a little longer than stigmal
GYRANUSOIDEA (p. 280)
- Forewing with postmarginal vein not longer than stigmal **ANAGYRUS** (p. 229)
- 269 (267) Scutellum with dense silvery white setae which are conspicuously more dense than those on mesoscutum and often arranged in a distinct pattern; at least some of the flagellar segments pale and contrasting with others which are dark 270
- Scutellum with dark setae, or if with white setae then these are not conspicuously deeper than on mesoscutum and are never arranged in a distinct pattern; flagellum usually unicolorous although occasionally with contrasting white and dark segments 271
- 270 (269) Forewing with postmarginal vein longer than stigmal; setae on scutellum not arranged in a distinct pattern; scape cylindrical and not conspicuously flattened, second segment of funicle white (Fig. 166) **APOLEPTOMASTIX** (p. 235)
- Forewing with postmarginal vein not longer than stigmal; setae on scutellum arranged in a distinct pattern; scape at least slightly broadened and flattened, second segment of funicle dark, not white **PARANATHRIX** (p. 317)

Figs 227–238 227, *Gahaniella saissetiae* Timberlake, right antenna, outer aspect, ♀; 228–230, *Pasulinia gentha* sp. n., (228) head, aspect from left side, ♀, (229) left mandible, ♀, (230) right antenna, outer aspect, ♀; 231, 232, *Protyn darichoides* spp., apex of right forewing venation, upper surface, ♀; 233–234, *Protyn darichoides* spp., right antenna, outer aspect, ♀; 235, *Cladiscodes sacchari* Subba Rao, right forewing, upper surface, ♀; 236, *Tachinaephagus* sp., base of left forewing, upper surface, ♀; 237, *Metaphaenodiscus aligarhensis* Hayat, apex of left forewing venation, upper surface, ♀; 238, *Exoristobia philippinensis* Ashmead, base of left forewing, upper surface, ♀.

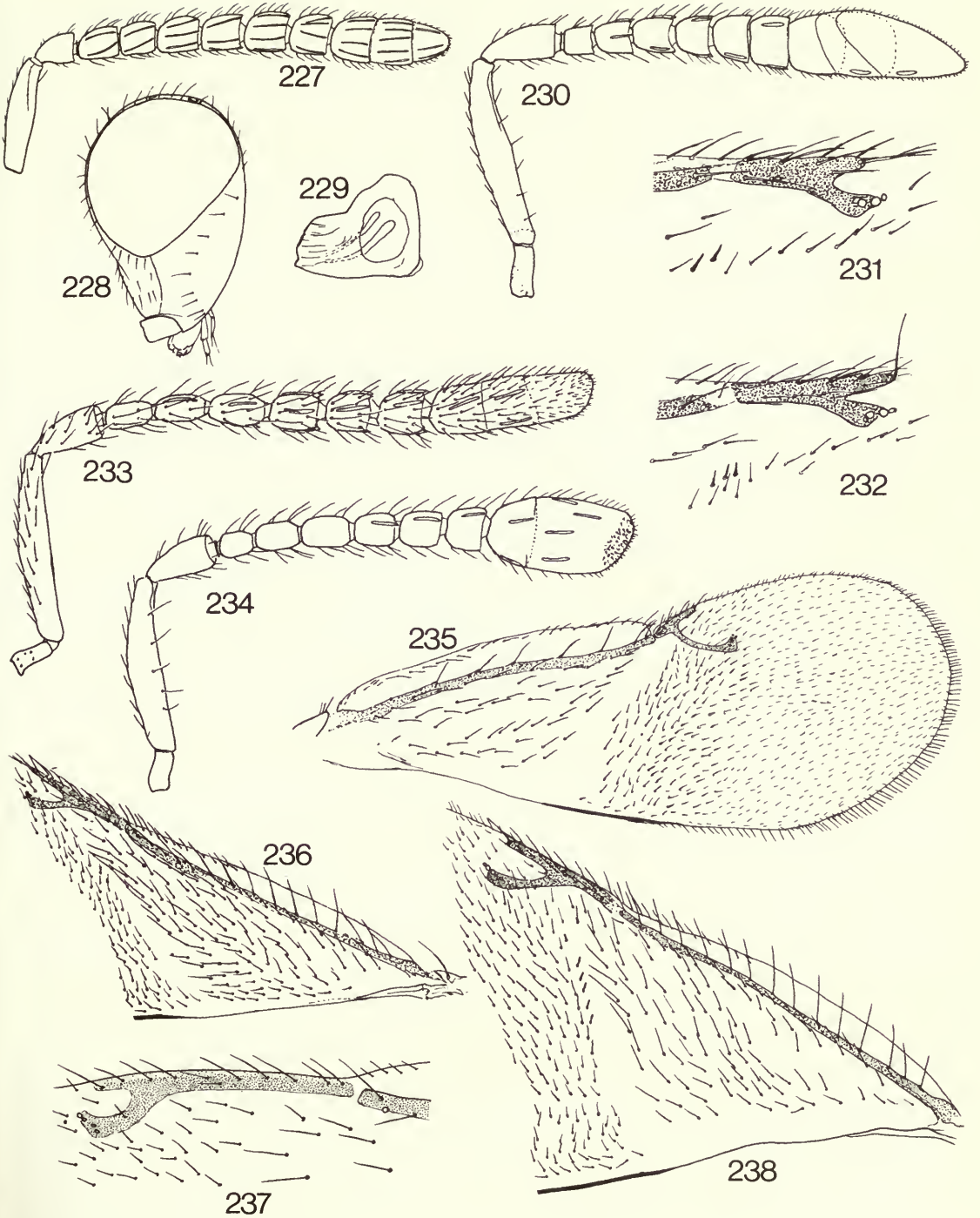

- 271 (269) Funicle seven-segmented, clava two-segmented (Figs 37, 167) 272
 - Funicle six-segmented, clava one- two- or three-segmented 273
- 272 (271) Forewing relatively broad, only a little more than twice as long as broad, stigmal vein moderately long and slender, postmarginal vein relatively long and distinct (Fig. 88) **ALAMELLA** (p. 227)
 - Forewing relatively slender, nearly three times as long as broad, stigmal vein very short, subsessile, postmarginal vein more or less absent (Fig. 162) **ANOMALICORNIA** (p. 232)
- 273 (271) Body distinctly dorso-ventrally flattened; pronotum longitudinally divided in middle (as in Fig. 38) **RHOPUS** (p. 332)
 - Body more robust, not clearly flattened; pronotum entire 274
- 274 (273) Clava entire (Fig. 169) **ANOMALENCYRTUS** (p. 232)
 - Clava three-segmented 275
- 275 (274) Either postmarginal vein or forewing as long or longer than stigmal (Figs 163, 164) or forewing relatively long and narrow and more than three times as long as broad 276
 - Postmarginal vein of forewing shorter than stigmal (Figs 98, 165) and forewing not more than three times as long as broad 277
- 276 (275) First funicle segment not longer than pedicel; generally smaller species (length less than 1.3 mm) **LEPTOMASTIDEA** (p. 292)
 - First funicle segment at least one and one-half times as long as pedicel (Fig. 168); generally larger species (length greater than 1.4 mm) **LEPTOMASTIX** (p. 293)
- 277 (275) Flagellum widening towards clava so that clava is nearly twice as broad as first funicle segment (Figs 173, 174); gaster white or pale orange at base, thorax brown; ovipositor hardly as long as mid tibia **BACALUSA** (p. 239)
 - Flagellum not clearly widening towards clava so that clava is not or hardly wider than first funicle segment (Fig. 175); gaster usually dark brown or if orange then thorax is also partly orange; ovipositor clearly longer than mid tibia **DOLIPHOCERAS** (p. 266)
- 278 (24)** Forewing with postmarginal vein longer than stigmal **PRIONOMASTIX** (p. 325)
 - Forewing with postmarginal vein not longer than stigmal 279
- 279 (278) Forewing with marginal vein absent, stigmal vein arising from submarginal before it reaches anterior margin of wing (Figs 171, 172); frontovertex usually with distinct piliferous punctures giving it a thimble-like appearance 280
 - Forewing with marginal vein present; frontovertex without conspicuous piliferous punctures 281
- 280 (279) Forewing with marginal fringe absent; mesoscutum with deep piliferous punctures giving it a thimble-like appearance; interantennal prominence normal; clava with apex more or less rounded **HETEROCOCCIDOXENUS** (p. 286)
 - Forewing with marginal fringe present; mesoscutum with raised reticulate sculpture, without deep piliferous punctures; interantennal prominence strongly produced into an acute tooth level with lowest margins of antennal toruli; clava with a strongly obliquely truncate apex (Fig. 170) **PARATETRACNEMOIDEA** (p. 318)
- 281 (279) Mesopleurum enlarged posteriorly so that it touches or nearly touches base of gaster, thorax in side view with hind coxa more or less clearly separated from metapleurum and propodeum by posterior margin of mesopleurum (Fig. 177); hypopygium not extending more than three-quarters along gaster 282

Figs 239–251 239, 240, *Lutherisca* sp., (239) left antenna, outer aspect, ♀, (240) apex of left forewing venation, upper surface, ♀; 241, *Copidosoma* sp., left antenna, outer aspect showing truncate sensory surface at apex of clava, ♀; 242, *Coccidoxenoides peregrinus* (Timberlake), base of left forewing, upper surface, ♀; 243, 244, *Neocharitopus* sp., (243) apex of right forewing venation, upper surface, ♀, (244) scutellum, dorsal aspect showing sculpture (left side) and distribution of setae (right side), ♀; 245, *Coagerus bouceki* sp. n., right forewing, ♀; 246, *Ooencyrtus* sp., right antenna, outer aspect, ♀; 247, *Coelopencyrtus* sp., apex of right forewing venation, upper surface, ♀; 248, *Coelopencyrtus* sp., base of right forewing, upper surface, ♀; 249, *Copidosoma* sp., base of right forewing, upper surface, ♀; 250, 251, *Zaommoencyrtus* spp., apex of right forewing venation, upper surface, ♀.

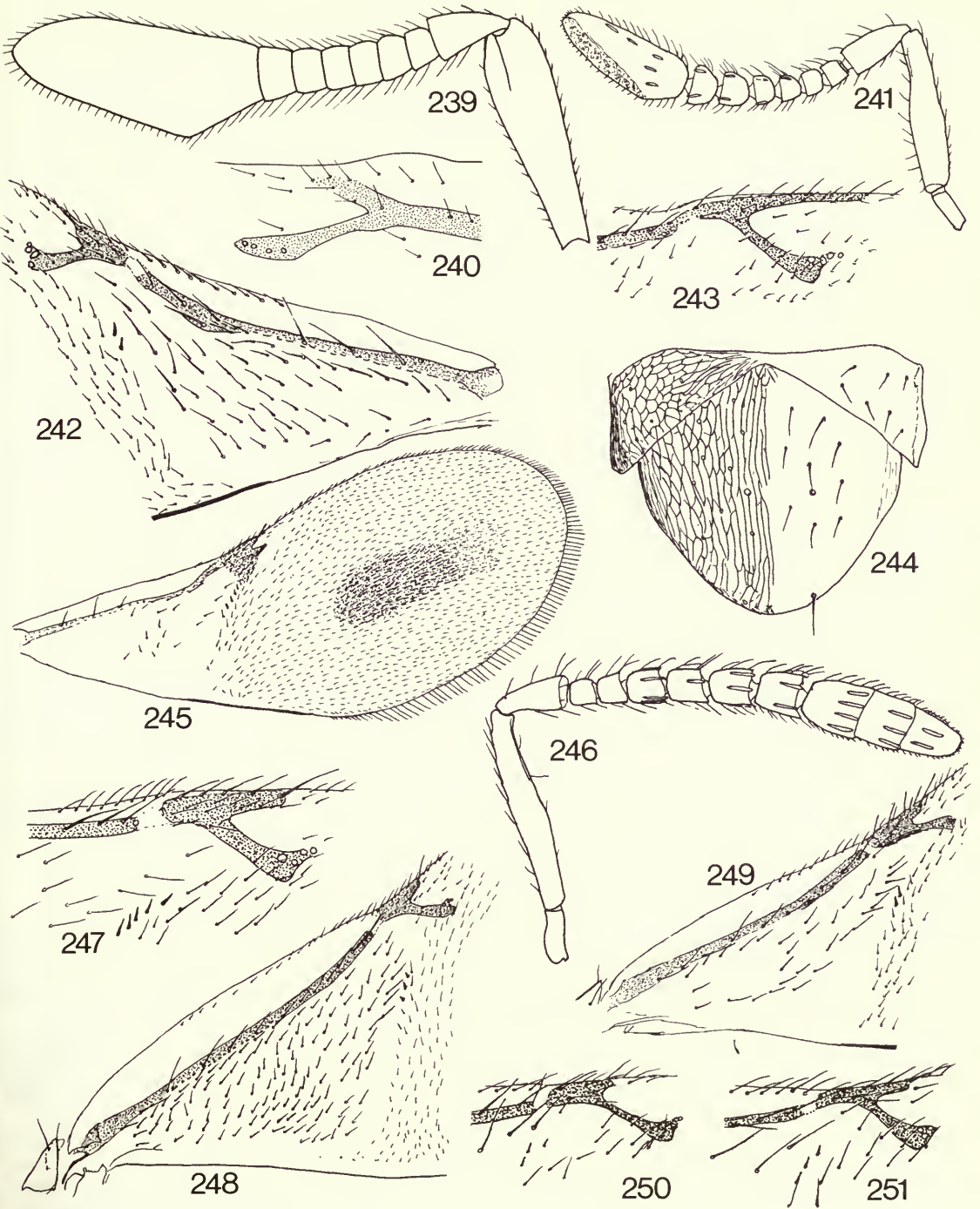

- Mesopleurum not so enlarged posteriorly, when thorax viewed from side the hind coxa is more or less broadly in contact with metapleurum and propodeum and is thus clearly separating mesopleurum from basal segment of gaster (Figs 102, 140, 176), or if as in alternate then hypopygium extends to apex of gaster 284
- 282 (281) Pedicel subtriangular, shorter than first funicle segment, clava not or hardly longer than first funicle segment; antennal toruli with lower margins at level of or above lower eye margins; frontovertex with relatively deep piliferous punctures and with an almost thimble-like appearance **BOTHRIOPHYRNE** (p. 243)
- Pedicel clearly much longer than broad and longer than first funicle segment; antennal toruli with their lower margins clearly much below lower eye margins; frontovertex with inconspicuous piliferous punctures 283
- 283 (282) Hind margin of mesoscutum more or less straight so that it does not project above axillae medially and therefore the axillae appear to meet (as in Fig. 42); mandible with three sharp teeth **HELEGONATOPUS** (p. 283)
- Hind margin of mesoscutum distinctly projecting backwards above axillae so that they appear to be quite widely separated when thorax viewed from above when thorax in normal resting position (as in Fig. 44); mandible almost always with one or two teeth and a truncation, although occasionally tridentate **OOENCYRTUS** (p. 309)
- 284 (281) Head and thorax mostly orange with some fuscous markings, but not metallic 285
- At least head and usually thorax completely dark and metallic, not orange 286
- 285 (284) Forewing with linea calva interrupted on dorsal surface by three or four lines of setae; exerted part of ovipositor about as long as gaster **AUSTRALAPHYCUS** (p. 237)
- Forewing with linea calva not interrupted, except perhaps by two or three setae; exerted part of ovipositor less than half as long as gaster **PARAPHYCUS** (p. 317)
- 286 (284) Antennal toruli almost touching mouth margin, separated by not more than half their own lengths; hypopygium extending to apex of gaster; mandible with three acute teeth 287
- Antennal toruli more than half their lengths from mouth margin; hypopygium not reaching more than two-thirds along gaster, or if so then mandible with one or two teeth and a truncation 288
- 287 (286) Forewing with sensillae at apex of stigmal vein symmetrical, arranged in a square, apex of stigmal vein without a distinct uncus (Fig. 183) **COPIDOSOMA** (p. 257)
- Forewing with sensillae at apex of stigmal vein not arranged in a square and not symmetrical, apex of stigmal vein with a distinct uncus **PRIONOMITOIDES** (p. 326)
- 288 (286) Ovipositor strongly exerted and with sheaths flattened from side to side and slightly downcurved towards apex (Fig. 176) (most apparent along ventral surface of sheaths) **CERCHYSIUS** (p. 247)
- Ovipositor not exerted, or if so then sheaths are more or less cylindrical in cross-section and are straight (ventral surface of sheaths straight or slightly tapering upwards) 289
- 289 (288) Mandible with one or two teeth and a truncation (Figs 121, 122); mesoscutum and scutellum usually green or blue-green and quite shiny, although occasionally dull **PSYLLAEPHAGUS** (p. 330)
- Mandible with three acute teeth; mesoscutum and scutellum dark with green and blue reflections, not strongly metallic **SYRPHOPHAGUS** (p. 338)

Figs 252–266 252, *Tassonia* sp., apex of right forewing venation, upper surface, ♀; 253, 254, *Haligra concolor* sp. n., (253) right antenna, outer aspect showing truncate sensory surface at apex of clava, ♀, (254) sculpture in centre of scutellum (area approx. 0.1 mm square), ♀; 255, *Adekitopus* sp., right antenna, outer aspect, ♀; 256–263, *Adekitopus gordhi* sp. n., (256) right antenna, outer aspect, ♀, (257) apex of right forewing venation, upper surface, ♀, (258) sculpture on frontovertex anterior to anterior ocellus (area approx. 0.1 mm square), ♀, (259) hypopygium, ♀, (260) right antenna, outer aspect, ♂, (261) base of right forewing, upper surface, ♂, (262) genitalia, ♂, (263) digits and associated structures; 264, *Anagyrietta* sp., left antenna, outer aspect, ♀; 265, *Amicencyrtus obscurus* Hayat, apex of right forewing venation, upper surface, ♀; 266, *Anagyrtus swzeyi* Timberlake, right antenna, outer aspect, ♀.

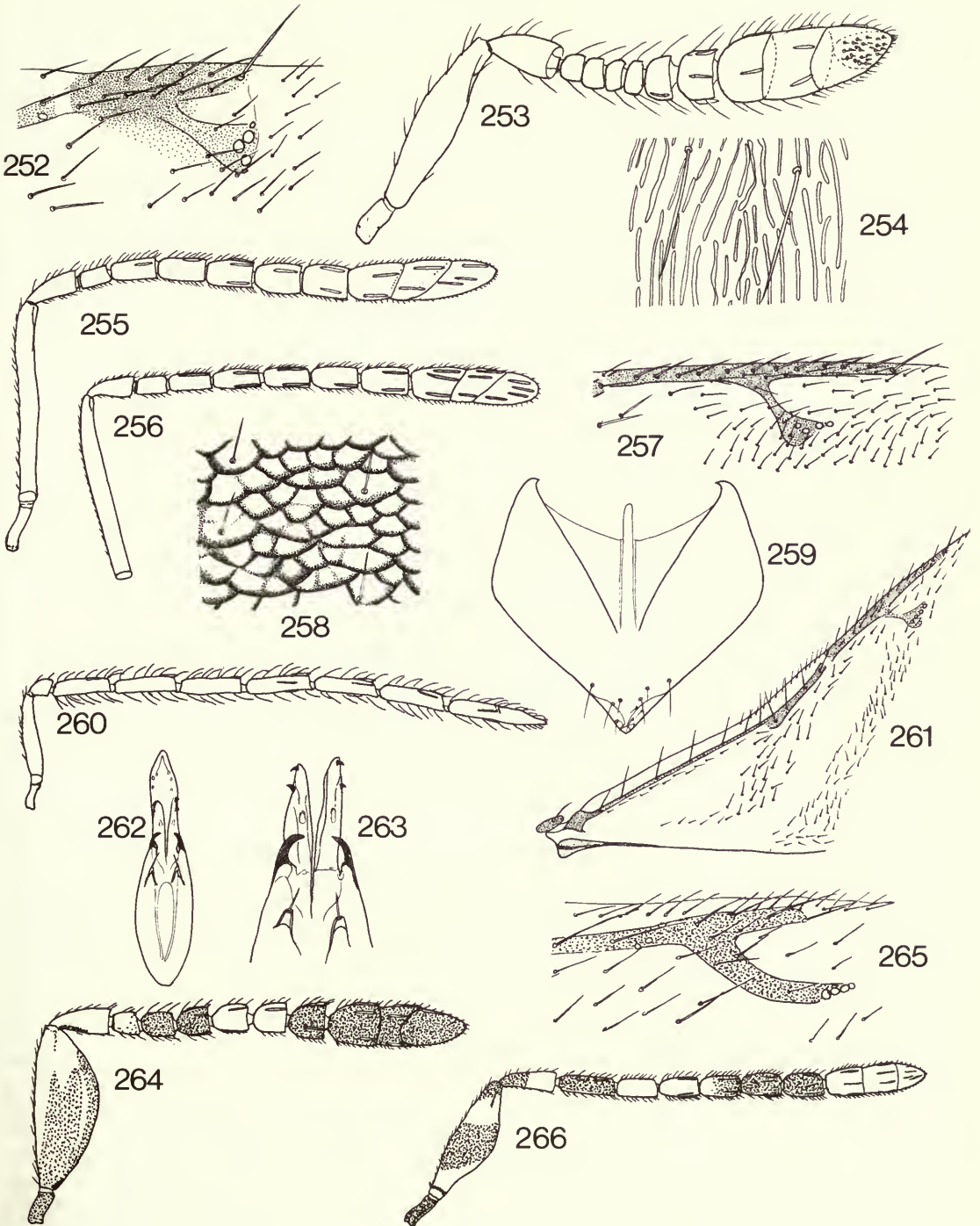

290 (25)	Antennal toruli situated relatively high on head and close together so that their distance from mouth margin is more than one and one-half times the minimum distance between them	HEXENCYRTUS (p. 286)
-	Distance of antennal toruli from mouth margin less than one and one-half times the distance between them	291
291 (290)	Clava entire	292
-	Clava three-segmented	294
292 (291)	Clava with a very strong oblique apical truncation which is much longer than remainder of ventral surface of clava; forewing with sensillae at apex of stigmal vein arranged symmetrically in a square, stigmal vein without a distinct uncus (Fig. 183)	COPIDOSOMA (p. 257)
-	Clava more or less apically rounded; forewing with sensillae at apex of stigmal vein asymmetrical and not arranged in a square, stigmal vein with an apical uncus	293
293 (292)	Hypopygium not reaching four-fifths along gaster	AUSTROENCYRTUS (p. 238)
-	Hypopygium reaching apex of gaster	ASEIRBA (p. 235)
294 (291)	Mandible bidentate	HEMILEUCOCERUS (p. 284)
-	Mandible tridentate or with one or two teeth and a truncation	295
295 (294)	Propodeum medially less than one-fifth as long as scutellum	296
-	Propodeum medially at least one-fifth as long as scutellum	303
296 (295)	Dorsum of thorax at least partly orange or yellow	XENOSTRYXIS (p. 348)
-	Dorsum of thorax dark brown, green or purple	297
297 (296)	Forewing with sensillae at apex of stigmal vein arranged symmetrically in a square; stigmal vein without a distinct apical uncus (Fig. 183) . . .	COPIDOSOMA (p. 257)
-	Forewing with sensillae at apex of stigmal vein not arranged in a square, asymmetrical; stigmal vein with a distinct apical uncus	298
298 (297)	Antenna long and filiform, funicle segments increasing in length so that sixth is about three times as long as broad, all segments of clava longer or hardly broader than sixth funicle segment (Fig. 179)	AUSTRALIA (p. 237)
-	Antenna not as in alternate; segments of clava only a little longer than broad, quadrate or transverse	299
299 (298)	Hypopygium reaching apex of gaster	300
-	Hypopygium not reaching apex of gaster	301
300 (299)	Hypopygium extending past apex of last tergite so that it is plainly visible in dorsal view (Fig. 125)	COCCIDICTONUS (p. 254)
-	Hypopygium not extending past apex of last tergite and not visible in dorsal view	RHOPELENCYRTOIDEA (p. 332)
301 (299)	Forewing with stigmal vein not more than one and one-half times as long as marginal (Fig. 186)	SYRPHOPHAGUS (p. 338)
-	Forewing with stigmal vein at least twice as long as marginal	302
302 (301)	Mandible with one or two teeth and a broad truncation (Figs 121, 122)	PSYLLAEPHAGUS (p. 330)
-	Mandible with three acute teeth (Fig. 178)	PARAENASOMYIA (p. 316)
303 (295)	Gaster with basal segment yellow or yellowish orange and contrasting with the dark remainder	PROTYNDARICHOIDES (p. 328)
-	Gaster unicolorous, dark and not paler basally	304
304 (303)	Ovipositor visible externally; scutellum with distinct reticulate sculpture; eye with short inconspicuous hairs, each not longer than diameter of a facet	305

Figs 267–279 267, *Anagyrus dactylopii* (Howard), left antenna, inner aspect, ♀; 268, *Anagyrus antoninae* Timberlake, right antenna, outer aspect, ♀; 269–271, *Aphycomorpha araucariae* Timberlake, (269) apex of right forewing venation, upper surface, ♀, (270) right antenna, outer aspect, ♀, (271) head, frontal aspect, ♀; 272, 273, *Aphycus* spp., (272) right antenna, outer aspect, ♀, (273) left forewing, upper surface, ♀; 274, 275, *Asitius phragmitis* (Ferrière), (274) apex of left forewing venation, upper surface, ♀, (275) head, frontal aspect, ♀; 276, *Astymachus japonicus* Howard, apex of left forewing venation, upper surface, ♀; 277, *Avetianella* sp., apex of left forewing venation, upper surface, ♀; 278, *Austroencyrtus* sp., right antenna, inner aspect, ♀; 279, *Bacalusa fuscipennis* sp. n., right forewing showing pattern of infuscation, ♀.

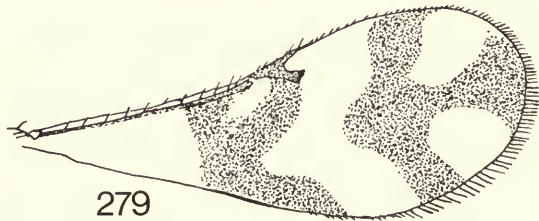
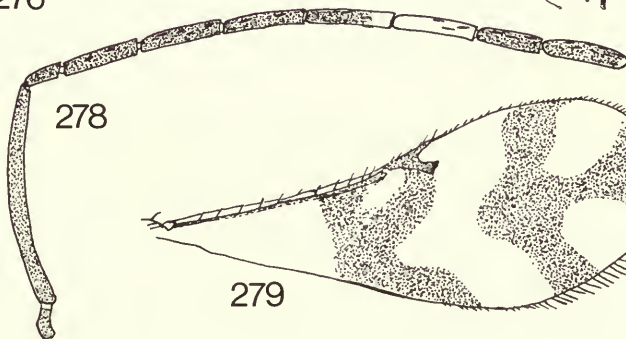
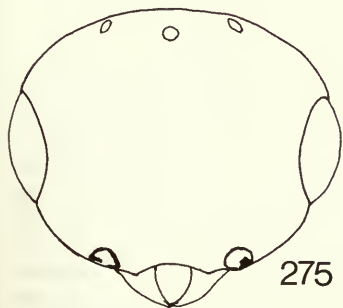
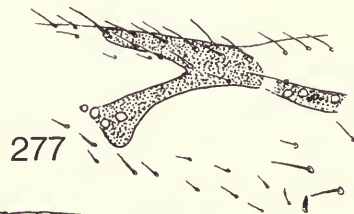
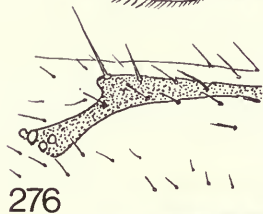
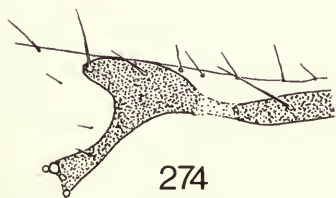
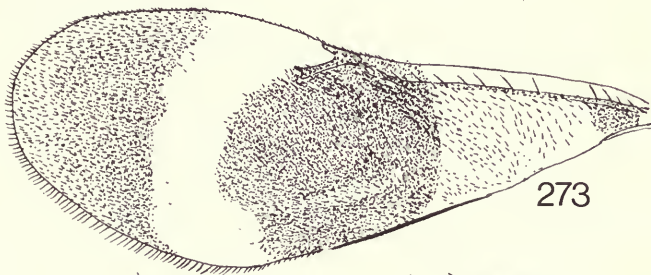
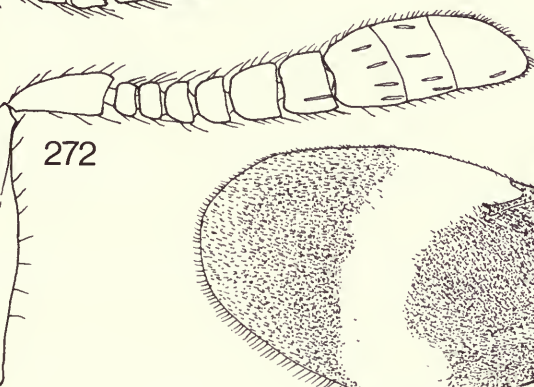
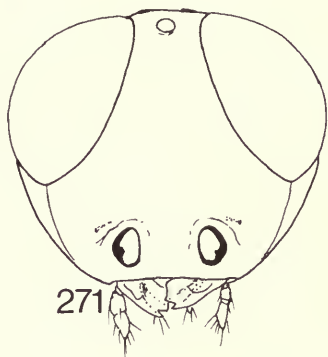
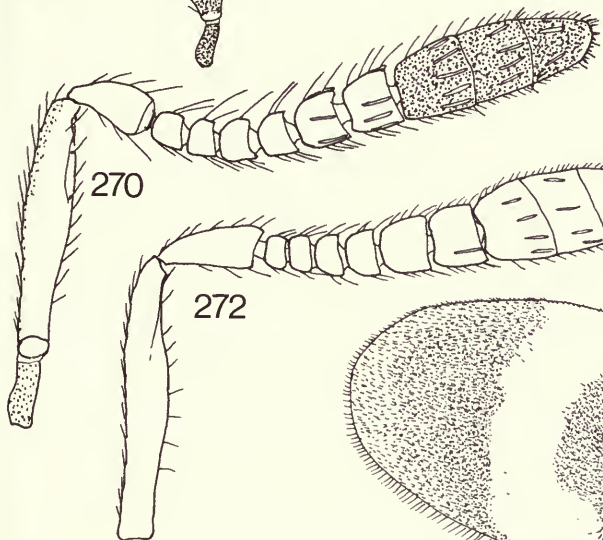
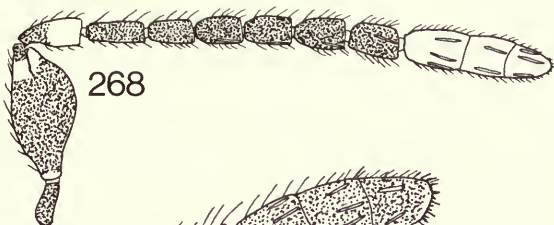
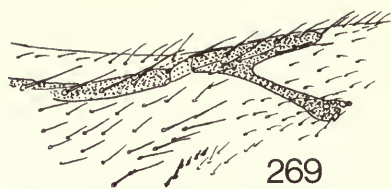
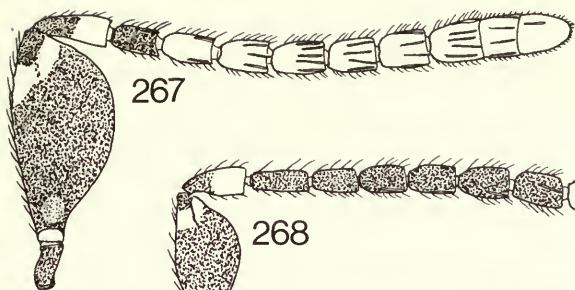

- Either ovipositor not visible externally or scutellum more or less smooth and shiny; eye distinctly hairy, each hair usually much longer than diameter of a facet 306
- 305 (304) Forewing with submarginal vein with parastigma clearly broadened and forming a weak triangular expansion, this indicated by a single erect seta (Fig. 147) **MAHENCYRTUS** (p. 294)
- Submarginal vein of forewing with parastigma not enlarged, not or hardly wider than proximal part of submarginal vein **ZOOENCYRTUS** (p. 350)
- 306 (304) Gonostyli free and not fused with second valvifers (Fig. 430) and at least slightly exerted and visible externally; scutellum always smooth and shiny **TACHINAEPHAGUS** (p. 340)
- Gonostyli fused with second valvifers (Fig. 415) and never visible externally; scutellum usually distinctly sculptured but occasionally smooth and shiny **RHYTHIDOTHORAX** (p. 333)
- 307 (26) Mesoscutum with an inconspicuous median longitudinal ridge in posterior half **HENGATA** (p. 284)
- Mesoscutum without a median longitudinal ridge 308
- 308 (307) Antennal scrobes long, straight and deeply impressed, clearly reaching to at least three-quarters distance from antennal toruli to anterior ocellus; interantennal prominence dorsally very sharply margined and pointed and clearly separated from frontovertex (Figs 184, 185) **TACHARDIAEPHAGUS** (p. 340)
- Antennal scrobes relatively shallow, more or less semi-circular and not long, reaching to at most a little more than half way between antennal toruli and anterior ocellus; interantennal prominence not pointed dorsally and not sharply margined, often confluent with frontovertex 309
- 309 (308) Pronotum triangular and conspicuous, in dorsal view about equal in length to mesoscutum (Fig. 149) **CHEILONEURELLA** (p. 248)
- Pronotum strongly transverse and inconspicuous, in dorsal view less than one-third as long as mesoscutum 310
- 310 (309) Neither postmarginal vein of forewing longer than stigmal nor eye with dense long setae (occasionally eye hairy, but hairs are not individually longer than a facet); hypopygium not reaching apex of gaster; mandible with one or two teeth and a truncation or rarely with three sharp teeth 311
- Either postmarginal vein of forewing longer than stigmal or eye clothed in conspicuous setae, each clearly much longer than diameter of a facet; hypopygium often reaching apex of gaster; mandible with from one to three sharp teeth 314
- 311 (310) Dorsum of thorax quite flat; hind leg yellow with one or two conspicuous dark bands; forewing with stigmal vein short, subsessile (Fig. 180) ... **PARASCHEDIUS** (p. 318)
- Dorsum of thorax conspicuously convex; legs completely yellow or yellow-orange without any conspicuous dark bands; forewing with stigmal vein relatively long (Figs 181, 182) 312
- 312 (311) Gaster unicolorous, from yellowish brown to orange-brown ... **NEASTYMACHUS** (p. 304)
- Gaster dark brown with a contrasting basal yellow band 313
- 313 (312) Mesopleurum enlarged and more or less touching basal segment of gaster so that when thorax viewed from side it clearly separates hind coxa from metapleurum and propodeum (Fig. 177); eye with very dense short, translucent hairs **OOENCYRTUS** (p. 309)

Figs 280–294 280–288, *Bacalusa fuscipennis* sp. n., (280) sculpture on frontovertex anterior to anterior ocellus (area approx. 0.1 mm square), ♀, (281) sculpture in centre of mesoscutum (area approx. 0.1 mm square), ♀, (282) sculpture in centre of scutellum (area approx. 0.1 mm square), ♀, (283) genitalia, ♀, (284) hypopygium, ♀, (285) head, frontal aspect, ♂, (286) right antenna, outer aspect, ♂, (287) genitalia, ♂, (288) digiti and apex of aedeagus; 289, 290, *Cerapteroceroides* sp., (289) right antenna, outer aspect, ♀, (290) apex of left forewing venation, upper surface, ♀; 291, 292, *Cerapteroceroides* sp., (291) apex of left forewing venation, upper surface, ♀, (292) left forewing showing pattern of infuscation, ♀; 293, 294, *Cercobelus jugaeus* (Walker) (extra-limital species), (293) right mandible, ♀, (294) head, frontal aspect, ♀.

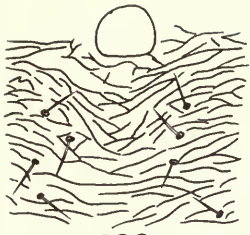

280

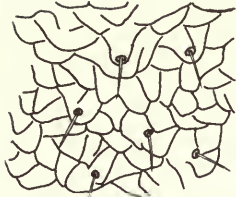

281

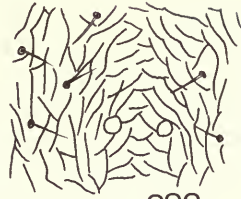

282

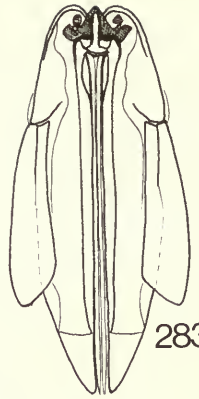

283

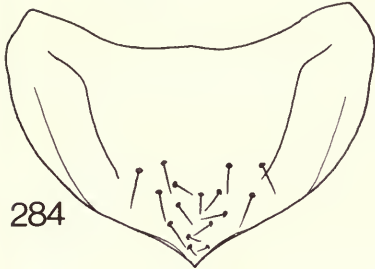

284

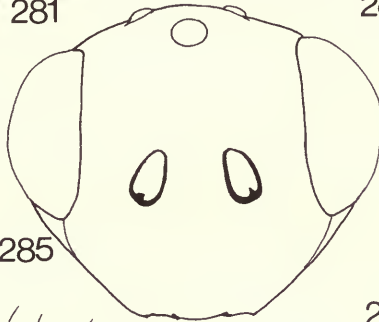

285



287



288

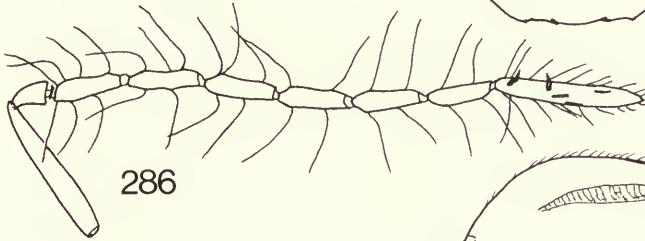

286

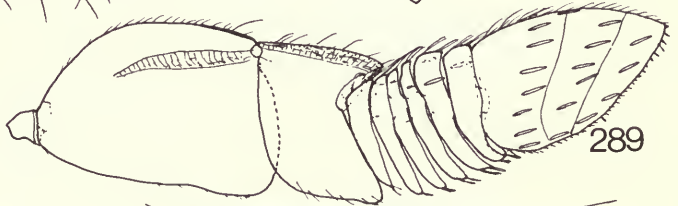

289

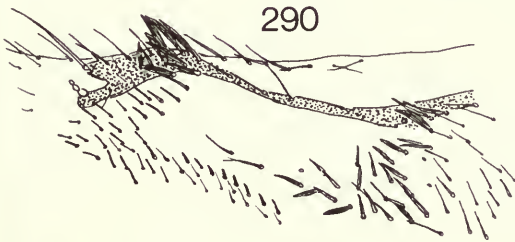

290

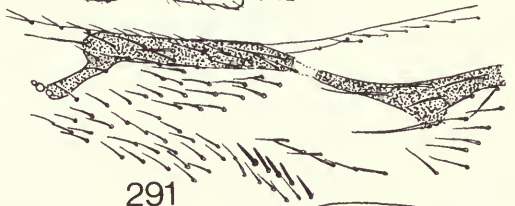

291

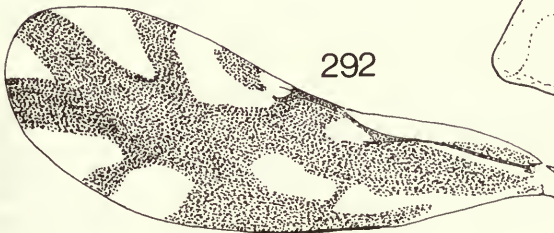

292

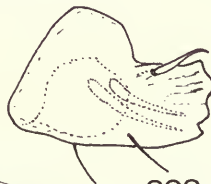

293

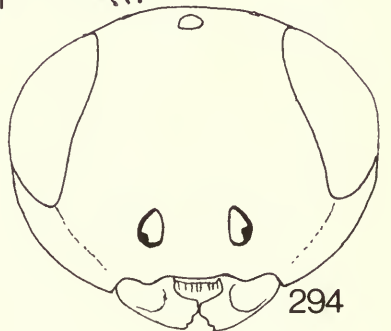

294

- Mesopleurum not so enlarged and not touching basal segment of gaster so that when thorax viewed from side metapleurum together with propodeum are narrowly in contact with hind coxa (as in Fig. 140); eye naked
- DIAPHORENCYRTUS** (p. 263)
- 314 (310) Mandible with three acute teeth and scutellum with deep reticulate sculpture . . . 315
- Either mandible with only one or two acute teeth or scutellum more or less smooth and shiny 316
- 315 (314) Hypopygium not extending more than two-thirds along gaster; forewing with postmarginal vein longer than stigmal (Figs 156, 187) **ETHORIS** (p. 275)
- Hypopygium extending to at least four-fifths along gaster; forewing with postmarginal vein rarely longer than stigmal 316
- 316 (314, 315) Ovipositor at least slightly exerted with sheaths flattened from side to side; gonostyli free and at least about one-quarter as long as ovipositor (Fig. 430); mandible with three acute teeth (Fig. 144) **TACHINAEPHAGUS** (p. 340)
- Ovipositor not exerted, gonostyli not visible externally and not more than one-fifth as long as ovipositor and fused to second valvifers (Fig. 415); mandible with one or two teeth **RHYTIDOTHORAX** (p. 333)
- 317 (26)** Scape shorter than minimum width of frontovertex 318
- Scape not shorter than minimum width of frontovertex 320
- 318 (317) Gaster dark with basal orange or yellow ring which contrasts with dark remainder **PROTYNDARICHOIDES** (p. 328)
- Gaster unicolorous, dark, without pale basal ring 319
- 319 (318) Legs, including coxae, completely yellow; malar space more than two-thirds as long as eye; forewing with setae extending to base (Fig. 132) **KATAKA** (p. 290)
- Legs with at least mid tibia and coxae brownish; malar space less than half as long as eye; forewing with proximal part of basal cell naked **KAKAOBURRA** (p. 289)
- 320 (317) Gaster with basal orange or yellow ring; head in profile anteriorly more or less evenly rounded; eyes not overreaching occipital margin which is sharp; mesopleurum not enlarged so that when thorax viewed from side hind coxa is in contact with metapleurum and propodeum (as in Figs 139, 140); mandible with three acute teeth **PROTYNDARICHOIDES** (p. 328)
- Gaster unicolorous, dark and usually slightly metallic, or if basal segment yellow then *either* head in profile is triangular and abruptly inflexed at top of antennal toruli (as in Fig. 72) and mandible with one tooth and a broad truncation *or* eyes overreach occipital margin which is more or less rounded and mesopleurum posteriorly enlarged so that when thorax viewed from side it clearly separates hind coxa from metapleurum and propodeum (Fig. 177) 321
- 321 (320) Scutellum with very elongate striate-reticulate sculpture; hypopygium not extending more than four-fifths along gaster; head in profile anteriorly more or less evenly rounded; mesopleurum not enlarged so that when thorax viewed from side hind coxa touches metapleurum and propodeum (as in Figs 139, 140) 322
- Scutellum without striate sculpture, or if appearing striate then either hypopygium reaches apex of gaster or head in profile triangular and abruptly inflexed at top of antennal scrobes (as in Fig. 72) or mesopleurum posteriorly enlarged and more or less touching basal segment of gaster so that when

Figs 295–308 295, *Cheiloneurella* sp., right antenna, outer aspect, ♀; 296–299, *Coagerus bouceki* sp. n., (296) apex of right forewing venation, upper surface, ♀, (297) scutellum and propodeum showing sculpture (left side) and distribution of setae (right side), ♀, (298) right antenna, outer aspect, also inner aspect of clava, ♀, (299) genitalia, right side, ventral aspect, ♀; 300, *Coelopencyrtus odyneri* Timberlake, right antenna, outer aspect, ♀; 301, *Coelopencyrtus* sp., right antenna, inner aspect, ♀; 302, 303, *Comperiella lemniscata* Compere & Annecke, (302) right antenna, outer aspect, ♀, (303) left forewing showing pattern of infuscation, ♀; 304, *Cremesina* sp., brachypterous species, right fore and hind wings, ♀; 305–308, *Cremesina aquilonaris* sp. n., (305) apex of right forewing venation, upper surface, ♀, (306) right antenna, outer aspect, ♀, (307) sculpture in centre of mesoscutum (area approx. 0.1 mm square), ♀, (308) genitalia, right side, ventral aspect, ♀.

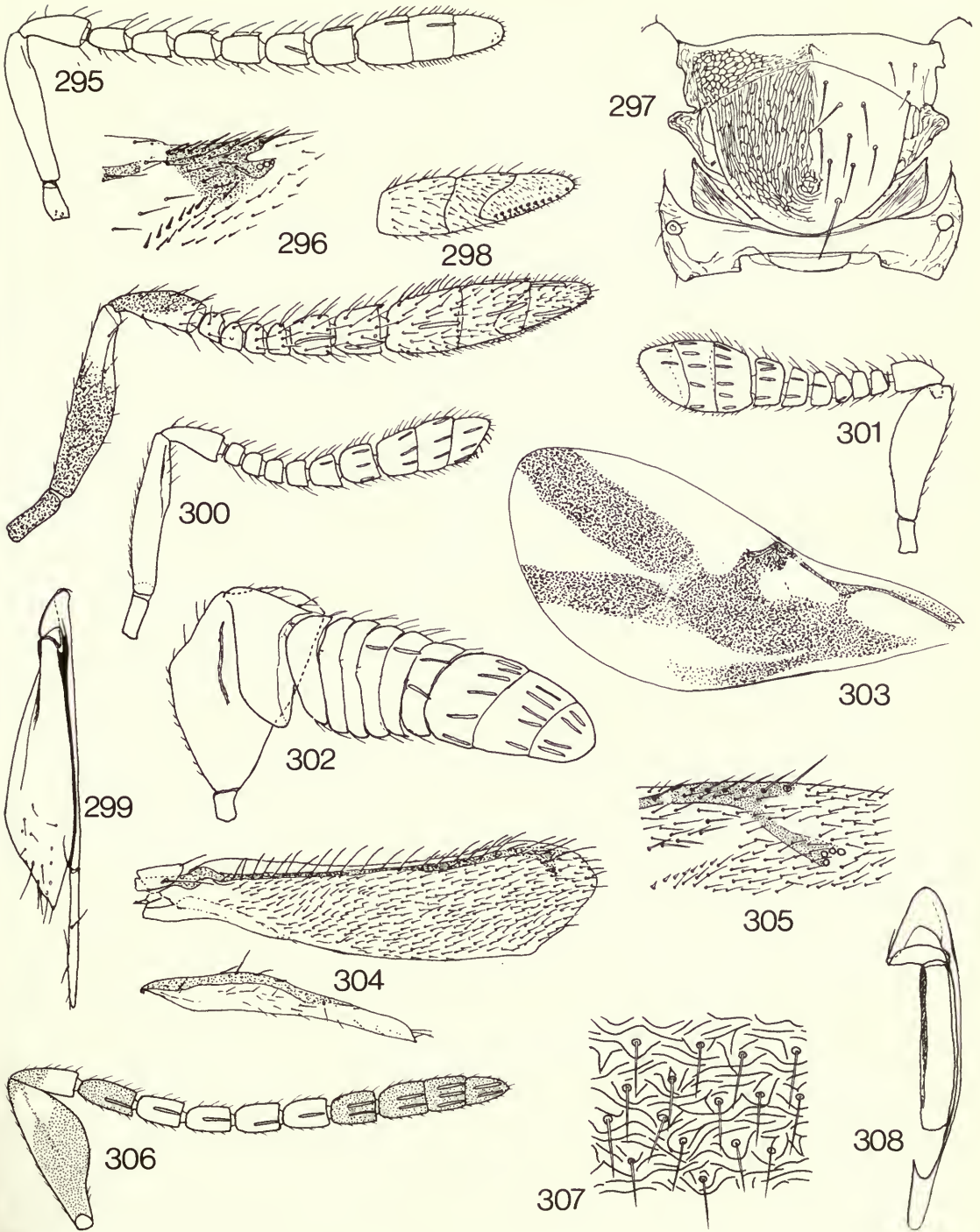

- thorax viewed from side it clearly separates hind coxa from metapleurum and propodeum (Fig. 177) 323
- 322 (321) Both mesoscutum and scutellum with striate-reticulate sculpture, that on scutellum very fine so that it is completely matt and not metallic; hypopygium reaching to only a little more than half way along gaster; mandible tridentate
NEGENIASPIDIUS (p. 305)
- Mesoscutum with shallow reticulate sculpture which contrasts strongly with the striate sculpture of scutellum; scutellum at least slightly metallic; hypopygium reaching to about four-fifths along gaster; mandible with four teeth (Fig. 188) although occasionally with only three *LAMENNAISIA* (p. 292)
- 323 (321) Hypopygium more or less reaching apex of gaster; forewing with postmarginal vein not or hardly longer than stigmal 324
- Hypopygium not extending more than three-quarters along gaster, or if so then postmarginal vein of forewing is at least one-half longer than stigmal 327
- 324 (323) Forewing with filum spinosum directed towards junction of submarginal and marginal veins and converging with setae on proximal margin of lineae calva (Fig. 127) *CERCHYSIELLA* (p. 246)
- Forewing with filum spinosum absent or directed towards junction of marginal and stigmal veins and subparallel to setae on proximal margin of lineae calva (Figs 152, 153, 158, 186, 238, 249; also as in Figs 134, 135, 139, 166) 325
- 325 (324) Eye not overreaching occipital margin, separated from occiput by a sharp occipital margin; forewing with sensillae at apex of stigmal vein arranged symmetrically in a square, uncus absent (Figs 142, 183) *COPIDOSOMA* (p. 257)
- Eye overreaching occipital margin which is rounded at this point; forewing with sensillae at apex of stigmal vein asymmetrical and not arranged in a square, uncus clearly present 326
- 326 (325) Forewing with marginal vein not more than twice as long as broad and at least a little shorter than stigmal, postmarginal vein a little shorter than stigmal
TRJAPITZINELLUS (p. 346)
- Forewing with marginal vein at least about four times as long as broad and longer than stigmal, postmarginal vein as long as or slightly longer than stigmal *PARECTROMOIDES* (p. 320)
- 327 (323) Head in profile triangular, abruptly inflexed at top of antennal scrobes (as in Fig. 72) 328
- Head in profile more or less gradually and evenly anteriorly rounded and not abruptly inflexed at top of antennal scrobes 330
- 328 (327) Mandible with four teeth or with one tooth and a truncation 329
- Mandible with three acute teeth 330
- 329 (328) Mandible with four teeth (Fig. 116) *ADELENCYRTUS* (p. 223)
- Mandible with one tooth and a broad truncation (Fig. 189) ... *COCCIDENCYRTUS* (p. 253)
- 330 (327, 328) Forewing with postmarginal vein at least one and one-half times as long as stigmal 331
- Forewing with postmarginal vein not or hardly longer than stigmal 332
- 331 (330) Mesopleurum posteriorly enlarged and more or less touching basal segment of gaster so that when thorax viewed from side it clearly separates hind coxa from metapleurum and propodeum (as in Fig. 177); mandible with three acute teeth *ENCYRTOIDEA* (p. 268)
- Mesopleurum not posteriorly enlarged so that when thorax viewed from side it is clearly separated from basal segment of gaster by metapleurum and pro-

Figs 309–324 309–313, *Cremesina aquilonaris* sp. n., (309) hypopygium, ♀, (301) right antenna, outer aspect, ♂, (311) genitalia, ♂, (312) apex of genitalia, ♂, (313) base of right forewing, upper surface, ♂; 314, 315, *Diasula glabriscutellum* (Girault), (314) left mandible, ♀, (315) left antenna, outer aspect, ♀; 316, *Cyrtocoryphes viridiceps* Timberlake, right antenna, outer aspect, ♀; 317–321, *Doddanusia* sp., (317) apex of right forewing venation, upper surface, ♀, (318) right antenna, outer aspect, ♀, (319) left mandible, ♀, (320) hypopygium, ♀, (321) genitalia, ♀; 322, 323, *Ectopiognatha* sp., (322) apex of left forewing venation, upper surface, ♀, (323) right antenna, outer aspect, ♀; 324, *Gahaniella saissetiae* Timberlake, apex of right forewing venation, upper surface, ♀.

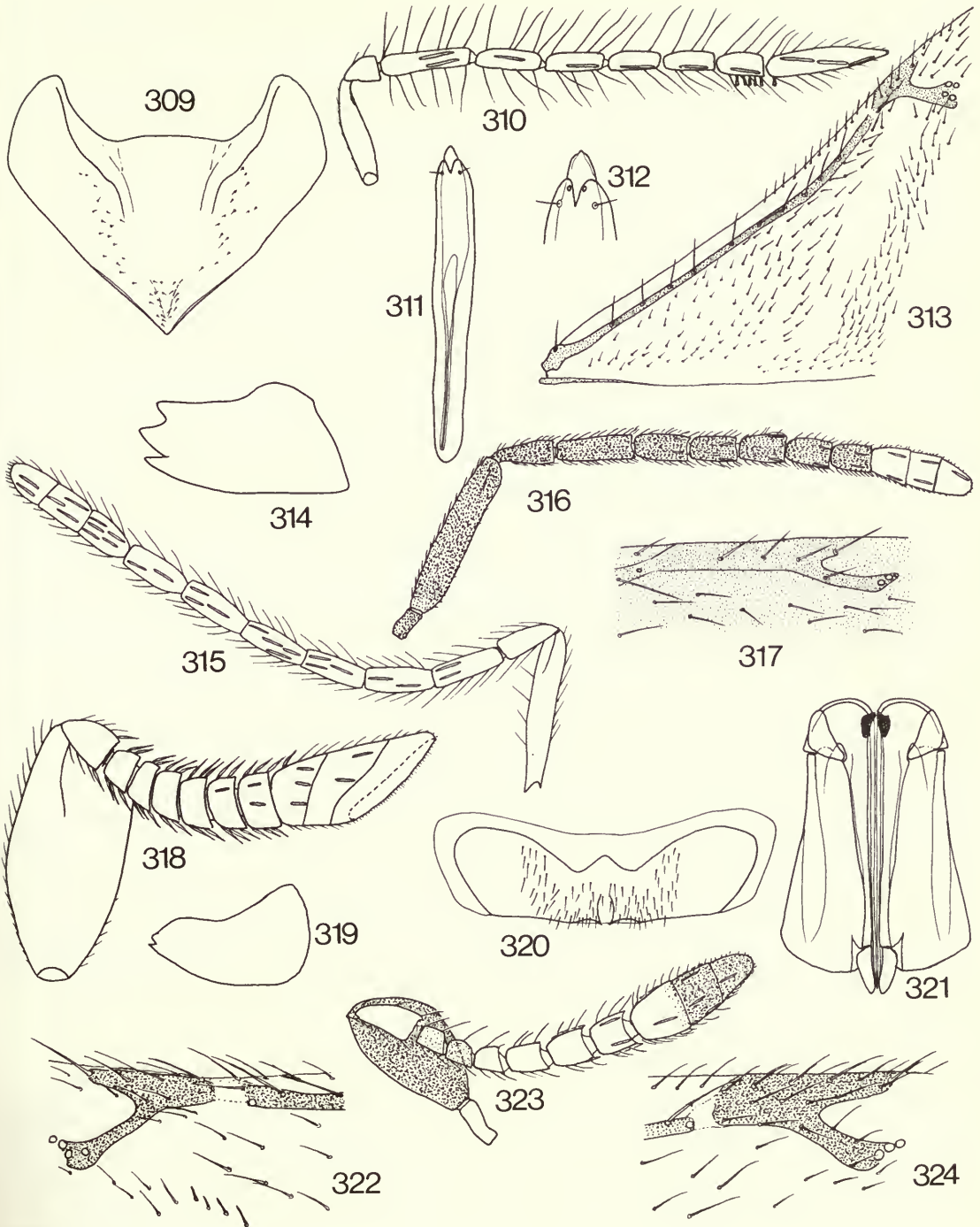

	podeum which are touching hind coxa (Fig. 139); mandible with one or two teeth	RHYTIDOTHORAX (p. 333)
332 (330)	Clava solid	ZAMENHOFELLA (p. 348)
-	Clava three-segmented	333
333 (332)	Scutellum flat and occipital margin rounded	MAYRIDIA (p. 295)
-	Scutellum convex, or if more or less flat than occipital margin sharp	334
334 (333)	Eye with conspicuous dense, dark setae, each longer than diameter of a facet; mesoscutum and scutellum clothed in dense recumbent dark setae so that dorsum of thorax is distinctly hairy	EXORISTOBIA (p. 277)
-	Eye with inconspicuous translucent setae, each not longer than diameter of a facet; mesoscutum and scutellum not noticeably hairy	335
335 (334)	Mandible tridentate	336
-	Mandible bidentate or with one or two teeth and a truncation	338
336 (335)	Posterior margin of mesoscutum more or less straight, not projecting above axillae medially so that when thorax is viewed from above the axillae meet medially (as in Fig. 42)	337
-	Posterior margin of mesoscutum clearly projecting backwards above axillae so that when thorax viewed from above and in normal resting position it broadly separates axillae medially (as in Fig. 44)	338
337 (336)	Ovipositor not or hardly exerted; forewing with postmarginal vein shorter than stigmal	HELEGONATOPUS (p. 283)
-	Either exerted part of ovipositor at least about one-fifth as long as gaster or postmarginal vein of forewing as long as or longer than stigmal	340
338 (335, 336)	Forewing with marginal vein less than twice as long as broad	339
-	Forewing with marginal vein at least twice as long as broad	340
339 (338)	Mandible bidentate; mesoscutum and scutellum both with deep punctate-reticulate sculpture and not shiny	FULGORIDICIDA (p. 278)
-	Mandibles not bidentate; mesoscutum never with punctate-reticulate sculpture and always slightly metallic, scutellum occasionally with punctate sculpture	OOENCYRTUS (p. 309)
340 (337, 338)	Mesopleurum posteriorly enlarged and more or less touching basal segment of gaster so that when thorax viewed from side it clearly separates hind coxa from metapleurum and propodeum (as in Figs 138, 177)	341
-	Mesopleurum not posteriorly enlarged so that when thorax viewed from side hind coxa clearly touches metapleurum and propodeum thus separating mesopleurum from basal segment of gaster (as in Figs 139, 140)	342
341 (340)	Occipital margin very sharp, carinate; eye not reaching occiput; head and thorax without pale setae; sculpture of scutellum often slightly deeper and finer than that of mesoscutum, but never strongly so	SYRPHOPHAGUS (p. 338)
-	Occipital margin rounded or sharp, but not carinate, or if carinate then scutellum has moderate to strong punctate sculpture which is conspicuously deeper than that of mesoscutum; eyes usually overreaching occipital margin; head and thorax often with conspicuous pale setae	TRICHOMASTHUS (p. 346)
342 (340)	Stigmal vein of forewing about twice as long as marginal	PARAENASOMYIA (p. 316)
-	Forewing with stigmal vein not more than one and one-half times as long as marginal	343
343 (342)	Propodeum medially not more than one-tenth as long as scutellum and devoid of	

Figs 325-341 325-327, *Eotopus beneficus* (Shafee), (325) right antenna, outer aspect, ♀, (326) genitalia, ♀, (327) genitalia, ♂; 328-331, *Eithoris dahmsi* sp. n., (328) right antenna, outer aspect, ♀, (329) right mandible, ♀, (330) genitalia, left side, ventral aspect, ♀, (331) head, frontal aspect, ♀; 332-339, *Gentakola trifasciata* (Saraswat), (332) head, dorso-frontal aspect, ♀, (333) genitalia, left side, ventral aspect, ♀, (334) base of left forewing, upper surface, ♀, (335) hypopygium, ♀, (336) genitalia, ♂, (337) digiti and apex of aedeagus, (338) base of right forewing, upper surface, ♂, (339) right antenna, outer aspect, ♂; 340, 341, *Haligra concolor* sp. n., (340) sculpture in centre of mesoscutum (area approx. 0.1 mm square), ♀, (341) left mandible, ♀.

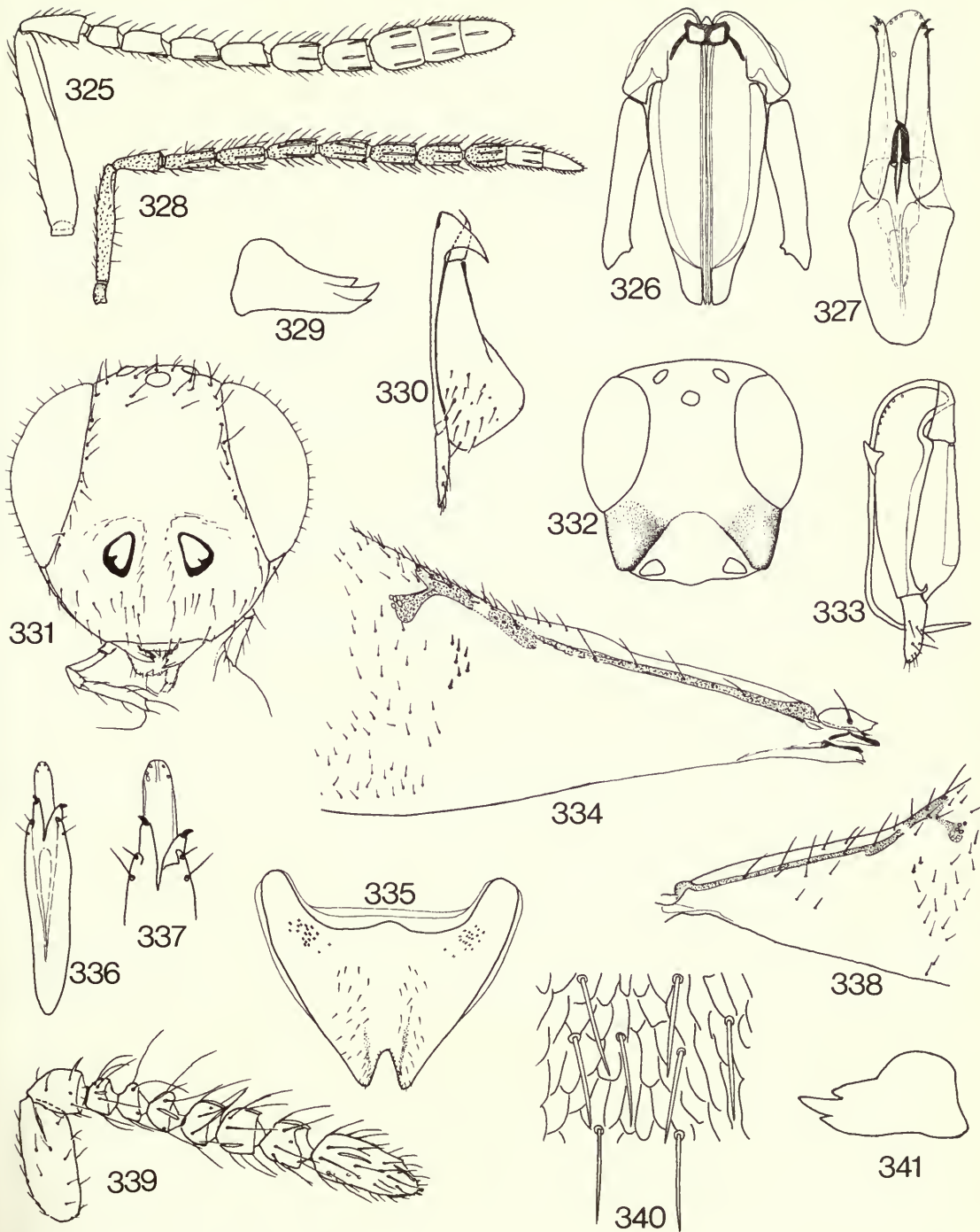

- a median carina; scutellum moderately convex but not very shiny
- Propodeum medially more than one-sixth as long as scutellum and with a shallow but distinct median carina; scutellum strongly convex and very shiny, at least in its apical one-half **SYRPHOPHAGUS** (p. 338)
- 344 (28)** Forewing with marginal vein punctiform or only very slightly longer than broad **DIASULA** (p. 263)
- Marginal vein of forewing at least twice as long as broad 346
- 345 (344)** Ovipositor sheaths strongly flattened from side to side and downcurved towards apex (Fig. 176); mandible with three acute teeth **CERCHYSIUS** (p. 247)
- Ovipositor sheaths more or less cylindrical and straight; mandible with one or two teeth and a truncation **PSYLLAEPHAGUS** (p. 330)
- 346 (344)** Forewing with postmarginal vein longer than stigmal (Fig. 190) **PAPUNA** (p. 312)
- Forewing with postmarginal vein not longer than stigmal 347
- 347 (346)** Forewing hyaline 348
- Forewing infusate 350
- 348 (347)** Head and thorax mostly yellowish with a few dark markings **XENOSTRYXIS** (p. 348)
- Head and thorax not yellowish, completely dark and more or less shiny 349
- 349 (348)** Forewing with marginal vein at least about three times as long as stigmal (Fig. 192); mesoscutum clothed in moderately dense white setae; scutellum fairly flat with deep reticulate sculpture contrasting with shallower sculpture of mesoscutum **ECHTHROGONATOPUS** (p. 267)
- Forewing with marginal vein at most only a little longer than stigmal, often shorter (Fig. 186); mesoscutum with dark setae; scutellum convex and with sculpture similar to that of mesoscutum **SYRPHOPHAGUS** (p. 338)
- 350 (347)** Infuscation of forewing limited to a longitudinal wedge-shaped mark from apex, submarginal vein with parastigma slightly enlarged into an indistinct triangular expansion indicated by a single erect seta (Fig. 147) **MAHENCYRTUS** (p. 294)
- Infuscation of forewing quite extensive and usually forming a distinct pattern, parastigma not or hardly swollen 351
- 351 (350)** Head in profile triangular and abruptly inflexed at top of antennal scrobes (as in Fig. 72); clava never obliquely truncate and with sutures subparallel; mesoscutum and scutellum never orange or yellowish, always dark and metallic **ADELENCYRTUS** (p. 223)
- Head in profile anteriorly more or less evenly curved, although occasionally slightly triangular but not strongly so; clava usually with an oblique apical truncation, or at least with sutures oblique and converging; mesoscutum or scutellum often partly orange or yellowish **CHEILONEURUS** (p. 249)
- 352 (28)** Forewing with marginal vein absent (Fig. 191) **COWPERIA** (p. 259)
- Forewing with marginal vein present, although sometimes short 353
- 353 (352)** Clava with a strong oblique apical truncation, the truncate surface about as long or longer than remainder of ventral surface (Figs 146, 193), if clava three-segmented then sutures strongly converge 354
- Clava apically more or less rounded or if with a slight oblique truncation then truncate surface clearly much shorter than remainder of ventral surface of clava and sutures, if present, subparallel or occasionally slightly converging 358
- 354 (353)** Notaular lines complete (Fig. 6) **HOMALOTYLUS** (p. 287)
- Notaular lines absent 355

Figs 342–357 342–345, *Haligra concolor* sp. n., (342) apex of left forewing venation, upper surface, ♀, (343) hypopygium, ♀, (344) base of right forewing, upper surface, ♀, (345) genitalia, ♀; 346, *Hamusencyrtus mymaricoides* (Compere, Subba Rao & Kaur), left antenna, inner aspect, ♀; 347–354, *Hengata spinosa* sp. n., (347) left mandible, ♀, (348) right antenna, outer aspect, ♀, (349) apex of right forewing venation, upper surface, ♀, (350) hypopygium, ♀, (351) genitalia, left side, ventral aspect, ♀, (352) right antenna, outer aspect, ♂, (353) genitalia, ♂, (354) digiti and associated structures; 355, 356, *Holanusomyia pulchripennis* Girault, (355) apex of right forewing venation and linea calva, upper surface, ♀, (356) left antenna, inner aspect, ♀; 357, *Indaphycus planus* Hayat, base of right forewing, upper surface, ♀.

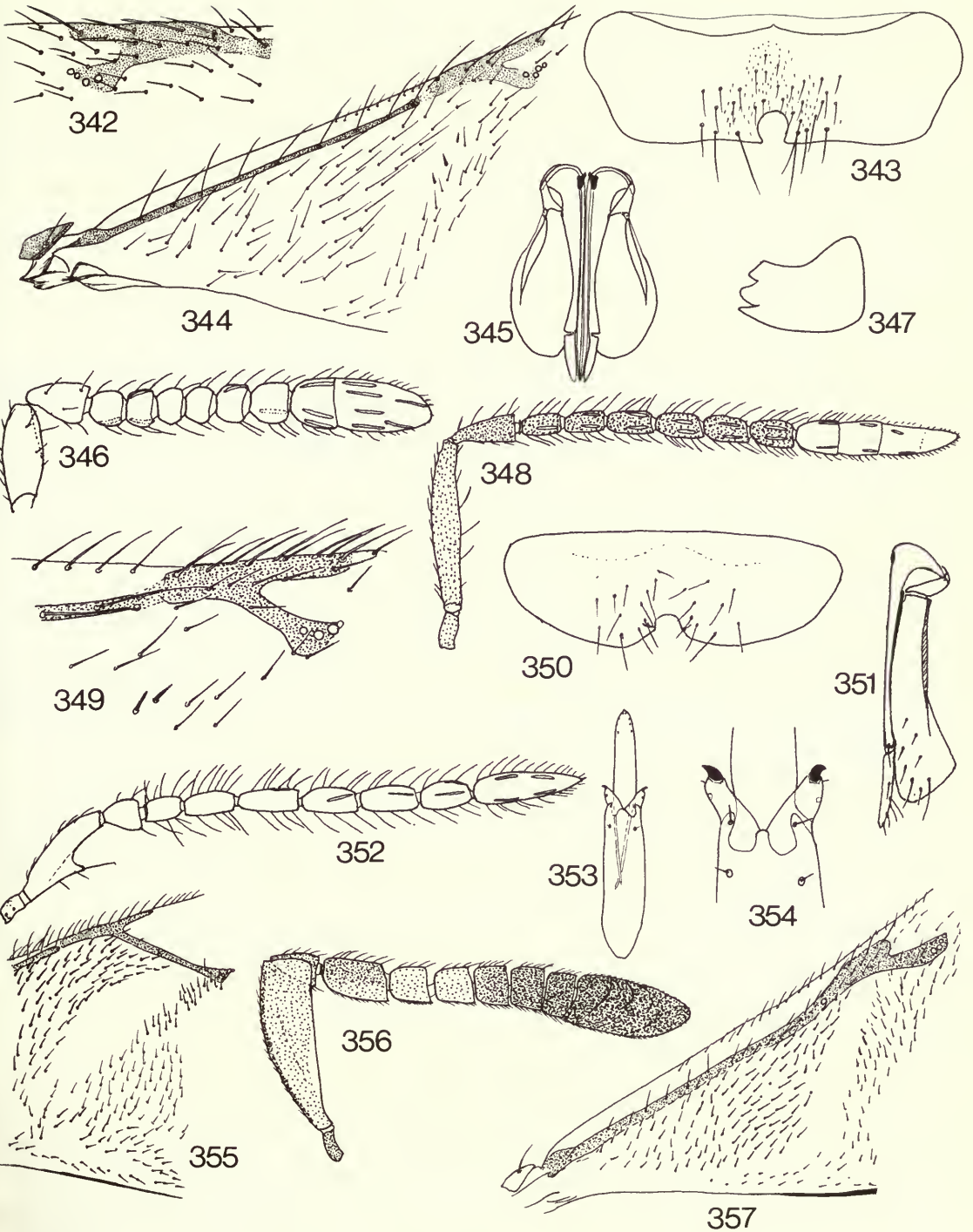

- 355 (354) Clava entire (Fig. 193); eyes clearly separated from occipital margin by at least the diameter of an ocellus **COPIDOSOMYIA** (p. 259)
- Clava three-segmented; eyes reaching or very nearly reaching occipital margin 356
- 356 (355) Forewing with marginal vein not longer than stigmal, wing completely hyaline except for a small inconspicuous cloud below marginal vein **PENTACLADOCERUS** (p. 322)
- Forewing with marginal vein at least three times as long as stigmal, forewing more strongly infusate 357
- 357 (356) Mesoscutum with a few scattered dark setae; dorsum of thorax completely dark and metallic, at least apical one-third of scutellum shiny **TINEOPHOCTONUS** (p. 343)
- Mesoscutum with moderate to very dense white setae; dorsum of thorax usually at least partly orange or yellow, although occasionally completely dark; scutellum, except extreme apex, with fine reticulate sculpture giving it a matt appearance ***PROCHILONEURUS** Silvestri (p. 327)
- 358 (353) Forewing infusate with a distinct dark pattern, or with a fuscous spot in centre of wing 359
- Forewing hyaline or generally suffused very pale brown, without a distinct pattern 363
- 359 (358) Forewing with postmarginal vein longer than stigmal; mesoscutum with deep piliferous punctures giving it a thimble-like appearance **BORROWELLA** (p. 242)
- Forewing with postmarginal vein not longer than stigmal; mesoscutum without deep piliferous punctures 360
- 360 (359) Forewing with infuscation restricted to a large pale fuscous spot below marginal vein, marginal vein punctiform (Fig. 197); notaular lines reaching to about one-third way across mesoscutum **PSEUDOCOCCOBIUS** (p. 329)
- Forewing with infuscation more distinct and extensive than in alternate, marginal vein usually at least a little longer than broad; notaular lines almost always absent 361
- 361 (360) Head and thorax never partly yellowish or orange, always completely dark and metallic; mandible bidentate **TETRACNEMUS** (p. 342)
- Head and thorax at least partly yellowish or orange; mandible tridentate 362
- 362 (361) Forewing with marginal vein at least five times as long as broad ***PROCHILONEURUS** Silvestri (p. 327)
- Forewing with marginal vein less than twice as long as broad (Fig. 199) **APHYCUS** (p. 234)
- 363 (358) Body largely yellow or orange, not metallic; notaular lines often present in anterior part of mesoscutum 364
- Body dark reddish, reddish brown or darker and often metallic; notaular lines absent 365
- 364 (363) Mandible with three acute teeth; notaular lines usually absent **APHYCUS** (p. 234)
- Mandible bidentate; notaular lines always present in anterior part of mesoscutum **EPISTENOTERYS** (p. 273)
- 365 (363) Dorsum of thorax at least partly reddish or reddish brown; scutellum moderately smooth and shiny; propodeum medially at least one-sixth length of scutellum and distinctly sculptured **TACHINAEPHAGUS** (p. 340)
- Dorsum of thorax completely dark and metallic; scutellum with distinct although sometimes shallow reticulate sculpture; propodeum medially not more than one-eighth as long as scutellum and not sculptured 366
- 366 (365) Hypopygium extending past apex of last tergite so that it is visible when gaster viewed from above (Fig. 125) 367
- Hypopygium not extending past apex of last tergite 368
- 367 (366) Ovipositor sheaths slightly but distinctly curving downwards towards apex; mandible with two teeth and a truncation; forewing never with postmarginal vein longer than stigmal **EPIBLATTICIDA** (p. 272)
- Ovipositor sheaths more or less straight and not curving downwards towards apex; mandible with three teeth; forewing with postmarginal vein often longer than stigmal **COCCIDOCTONUS** (p. 254)

* Not to be confused with *Procheiloneurus* Girault (p. 326)

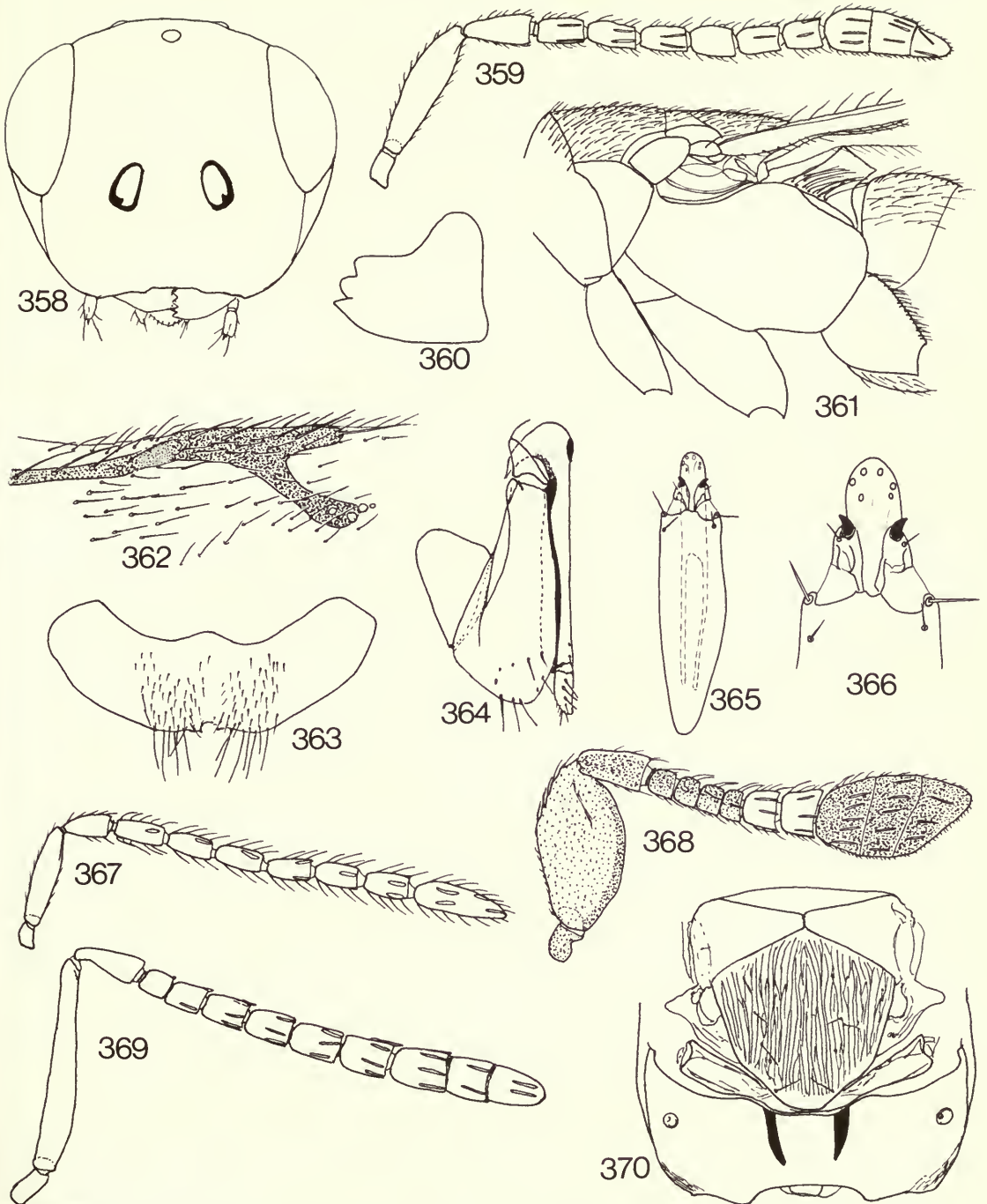

Figs 358–370 358–367, *Kataka mudigerensis* sp. n., (358) head, frontal aspect, ♀, (359) right antenna, outer aspect, ♀, (360) left mandible, ♀, (361) thorax, aspect from left side, ♀, (362) apex of right forewing venation, upper surface, ♀, (363) hypopygium, ♀, (364) genitalia, right side, ventral aspect, ♀, (365) genitalia, ♂, (366) digiti and apex of aedeagus, (367) right antenna, outer aspect, ♂; 368, *Lakshaphagus hautefeuilli* (Mahdihassan), right antenna, outer aspect, ♀; 369, 370, *Manicnemus indicus* (Mani & Saraswat), (369) right antenna, outer aspect, ♀, (370) scutellum and propodeum showing sculpture of scutellum, ♀.

- 368 (366) First funicle segment anelliform and clearly much smaller than the second which is subquadrate; mandible with one tooth and a broad truncation *BACHIANA* (p. 241)
- First funicle segment subequal in size to second and both clearly transverse; mandible with three sharp teeth 369
- 369 (368) Forewing with postmarginal vein longer than stigmal . . . *RHOPALENCYRTOIDEA* (p. 332)
- Forewing with postmarginal vein not longer than stigmal *TELETEREBRATUS* (p. 341)
- 370 (30) Scutellum extremely convex and dome-like and separated from axillae by deep grooves; antennal flagellum strongly compressed from side to side, clava entire *ANANUSIA* (p. 231)
- Scutellum not or hardly convex and never dome-like, not separated from axillae by deep grooves; antennal flagellum usually cylindrical to oval in cross-section, but if flattened then clava three-segmented 371
- 371 (370) Either first funicle segment longer than pedicel or forewing with postmarginal vein longer than stigmal; notaular lines absent 372
- Neither first funicle segment longer than pedicel nor postmarginal vein of forewing longer than stigmal, or if postmarginal vein a little longer than stigmal then notaular lines present 374
- 372 (371) Eye clearly reaching occipital margin; posterior ocellus distinctly nearer to eye than to occipital margin; mandible with three teeth *PARENCRYTOMYIA* (p. 320)
- Eye separated from occipital margin by at least about the diameter of a facet; posterior ocellus at least as near to occipital margin as to eye; mandible truncate without teeth 373
- 373 (372) Forewing with postmarginal vein longer than stigmal; frontovertex distinctly broader than half head width *PRIONOMASTIX* (p. 325)
- Forewing with postmarginal vein not longer than stigmal; frontovertex less than half head width *ENCYRTUS* (p. 268)
- 374 (371) Hypopygium not reaching more than four-fifths along gaster; cerci situated in basal half of gaster 375
- Hypopygium reaching or almost reaching apex of gaster; cerci often situated in apical half of gaster 385
- 375 (374) Either forewing with linea calva interrupted or closed on dorsal surface by at least one line of setae in posterior one-third (Fig. 104), or posterior margin of pronotum whitish or yellowish and contrasting with orange or darker colour of remainder of pronotum or mesoscutum 376
- Forewing with linea calva not interrupted and open posteriorly; posterior margin of pronotum translucent or concolorous with mesoscutum 378
- 376 (375) Mesoscutum and scutellum largely metallic green *ZARHOPALOIDES* (p. 349)
- Neither mesoscutum nor scutellum metallic, usually yellow, orange or dark brown 377
- 377 (376) Mandible with three acute teeth *METAPHYCUS* (p. 298)
- Mandible with one tooth and a broad truncation (as in Fig. 189) *APHYCOPSIS* (p. 233)
- 378 (375) Apex of clava obliquely truncate with truncate surface longer than adjacent surface on same side of clava and sutures oblique and converging (Fig. 194); forewing with marginal vein not longer than stigmal *MASHHOODIELLA* (p. 295)
- Apex of clava rounded, sutures more or less parallel, or if truncate then either truncate surface shorter than adjacent surface on same side of clava or marginal vein of forewing at least twice as long as stigmal 379

Figs 371–384 371–373, *Muluencyrtus nudipennis* sp. n., (371) left antenna, outer aspect (from card-mounted specimen), ♀, (372) head, frontal aspect (from card-mounted specimen), ♀, (373) right forewing, upper surface (from card-mounted specimen), ♀; 374–376, *Nathismusia southwoodi* sp. n., (374) left antenna, outer aspect (from card-mounted specimen), ♀, (375) head, frontal aspect (from card-mounted specimen), ♀, (376) apex of left forewing venation, upper surface, ♀; 377, 378, *Neodusmetia sangwani* (Subba Rao), (377) right antenna, outer aspect, ♀, (378) head, frontal aspect, ♀; 379, *Olypusa hirsuta* sp. n., left antenna, outer aspect, ♂; 380, *Neocharitopus* sp., right antenna, outer aspect, ♀; 381, *Ooencyrtus* sp., left mandible, ♀; 382–384, *Ovaloencyrtus fijiensis* sp. n., (382) apex of right forewing venation, upper surface (discal setae omitted), ♀, (383) genitalia, ♀, (384) hypopygium, ♀.

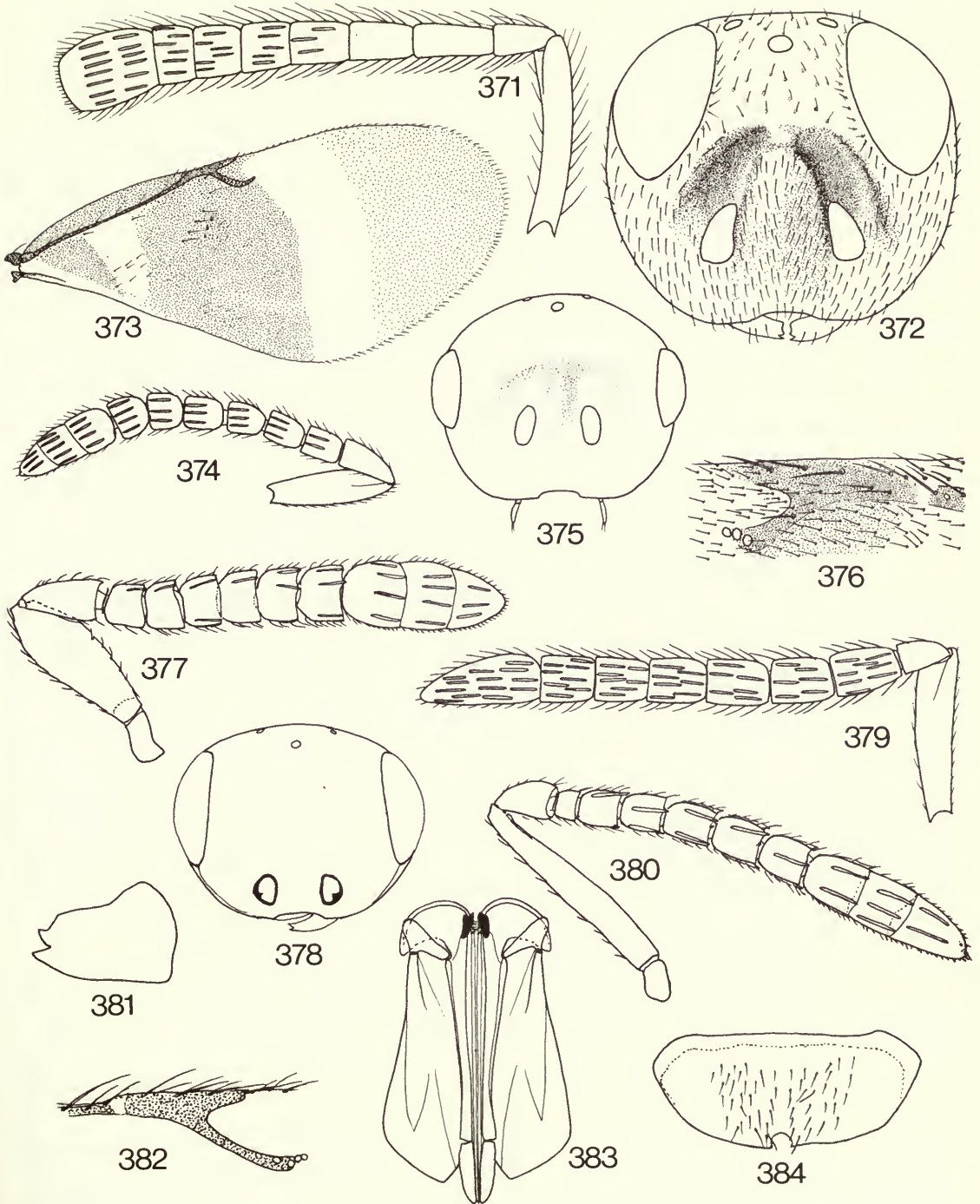

- 379 (378) Inner margins of eyes clearly converging below anterior ocellus; mesopleurum not posteriorly enlarged so that when gaster viewed from side metapleurum and propodeum are at least narrowly touching hind coxa (as in Fig. 139) *CHEILONEUROMYIA* (p. 249)
- Inner margins of eyes not converging below anterior ocellus; mesopleurum often posteriorly enlarged and more or less touching basal segment of gaster so that when thorax viewed from side it clearly separates hind coxa from metapleurum and propodeum (as in Figs 138, 177) 380
- 380 (379) Scutellum with a very thin, apical flange which projects above median part of propodeum *PARAPHAENODISCUS* (p. 317)
- Scutellum without an apical flange 381
- 381 (380) Forewing with marginal vein punctiform or nearly so *OOENCYRTUS* (p. 309)
- Forewing with marginal vein at least about three times as long as broad 382
- 382 (381) Forewing with marginal vein less than one and one-half times as long as stigmal; thorax never strongly metallic 383
- Forewing with marginal vein at least twice as long as stigmal; thorax often partly lustrous and metallic 384
- 383 (382) Posterior margin of mesoscutum projecting above axillae so that axillae appear to be separated (as in Fig. 44); scutellum flat, smooth and shiny; clava and apical funicle segments white and contrasting with dark proximal segments *LEEFMANSIA* (p. 292)
- Posterior margin of mesoscutum not projecting above axillae, axillae more or less meeting in middle, separated only by a short carina; scutellum usually convex or if flat then with distinct sculpture; clava dark and concolorous with proximal funicle segments *MICROTERTYS* (p. 299)
- 384 (382) Basal cell of forewing with two areas of dark setae either side of a naked area or fascia of pale translucent setae **PROCHEILONEURUS* Girault (p. 326)
- Basal cell of forewing with only one area of dark setae, this adjacent to linea calva, proximal of this either naked or a small patch of pale setae *CHEILONEURUS* (p. 249)
- 385 (374) Forewing with marginal vein at least twice as long as stigmal (Fig. 196); propodeum medially at least half as long as scutellum (Fig. 195) *SAKENCYRTUS* (p. 336)
- Forewing with marginal vein not longer than stigmal, or if slightly so then propodeum medially much less than half as long as scutellum 386
- 386 (385) Notaular lines absent; paratergites present (at least represented by a membranous strip) *PARECTROMOIDEA* (p. 319)
- Notaular lines present in at least anterior one-third of mesoscutum; paratergites absent 387
- 387 (386) Notaular lines complete 388
- Notaular lines not reaching more than half way across mesoscutum 389
- 388 (387) Forewing with stigmal vein straight, not abruptly bent immediately below marginal vein and thus forming an angle of about 45°, linea calva clearly open towards posterior margin of wing (Fig. 199) *APHYCUS* (p. 234)
- Forewing with stigmal vein abruptly bent below marginal vein and thus running nearly parallel to anterior margin of wing and forming an angle of clearly less than 30°, linea calva closed towards posterior margin of wing by at least two lines of setae on dorsal surface (Fig. 198) *HOMALOTYLUS* (p. 287)
- 389 (387) Clava solid with a strong oblique truncation (Fig. 200); forewing with stigmal vein arising from submarginal vein before it reaches anterior wing margin, linea calva broadening towards posterior wing margin and very clearly open (Fig. 201) *ISODROMUS* (p. 289)
- Clava two- or three-segmented with apex rounded; forewing with stigmal vein arising from marginal vein at anterior wing margin, linea calva with sides subparallel and more or less closed near posterior margin by setae on dorsal surface of wing (Fig. 197) 390
- 390 (389) Clava two-segmented; mandible bidentate *EPISTENOTERTYS* (p. 273)
- Clava three-segmented; mandible tridentate *PSEUDOCOCCOBIUS* (p. 329)

* Not to be confused with *Prochiloneurus* Silvestri (p. 327)

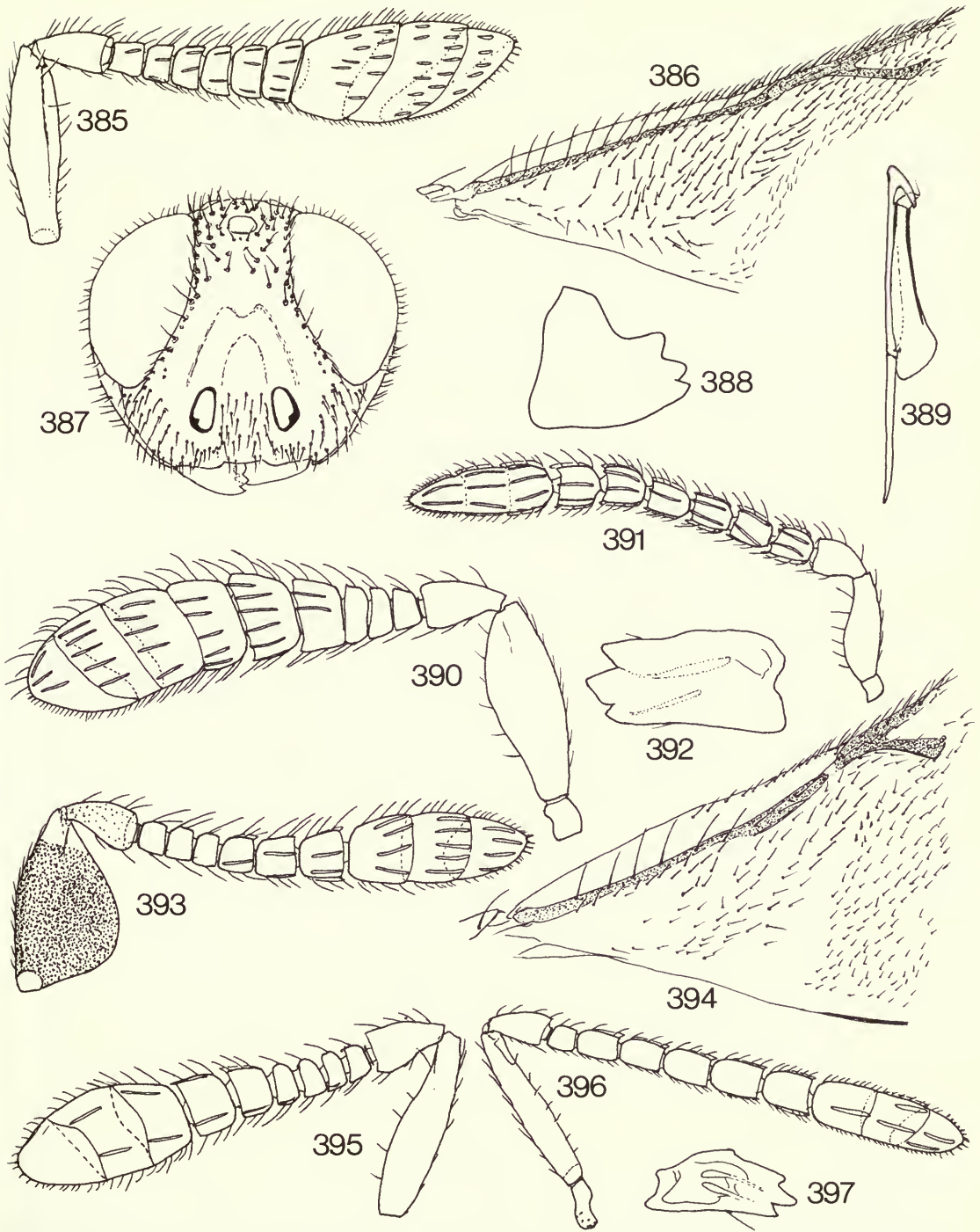

Figs 385–397 385–389, *Papuna nemis* sp. n., (385) right antenna, outer aspect, ♀, (386) base of right forewing, upper surface, ♀, (387) head, frontal aspect, ♀, (388) right mandible, ♀, (389) genitalia, left side, ventral aspect, ♀; 390–395, *Parablatticida* spp., (390) left antenna, outer aspect, ♀, (391) left antenna, outer aspect, ♂, (392) left mandible, ♀, (393) right antenna, outer aspect, ♀, (394) base of right forewing, upper surface, ♀, (395) left antenna, outer aspect, ♀; 396, 397, *Paraclausenia herbicola* Hayat, (396) right antenna, outer aspect, ♀, (397) right mandible, ♀.

- 391 (31) Mesopleurum posteriorly enlarged and more or less touching basal segment of gaster so that when thorax viewed from side it clearly separates hind coxa from metapleurum and propodeum (as in Figs 138, 177) 392
- Mesopleurum not enlarged so that when thorax viewed from side hind coxa touches metapleurum and propodeum thus separating mesopleurum from gaster (as in Figs 139, 140) 394
- 392 (391) Antennal scrobes narrow, elongate and deeply impressed, separated from anterior ocellus by only a little more than its own diameter; interantennal prominence very long and dorsally sharply delimited, pointed and clearly separate from frontovertex (Figs 184, 185) **TACHARDIAEPHAGUS** (p. 340)
- Antennal scrobes relatively shallow, not long and more or less semicircular and dorsally separated from anterior ocellus by at least twice its diameter; interantennal prominence dorsally more or less rounded or confluent with frontovertex and not sharply delimited 393
- 393 (392) Clava very large with a strong oblique apical truncation and at least twice as long as funicle (Fig. 202); mesoscutum and scutellum with striate-reticulate sculpture (Fig. 203) **AGARWALENCYRTUS** (p. 226)
- Clava smaller, usually shorter than funicle although occasionally a little longer, but never twice as long, usually more or less apically rounded, although occasionally with a short oblique truncation (Fig. 246); mesoscutum and scutellum without striate-reticulate sculpture **OOENCYRTUS** (p. 309)
- 394 (391) Clava entire (Fig. 204) **COPIDOSOMA** (p. 257)
- Clava two- or three-segmented 395
- 395 (394) Body strongly flattened; pronotum longitudinally divided in middle (as in Fig. 38); mandible bidentate with two equal teeth **RHOPUS** (p. 332)
- Body not flattened; pronotum entire; mandible not bidentate, or if so then teeth are unequal in length 396
- 396 (395) Antennal scrobes extending more than half way between toruli and anterior ocellus, their upper limit not semicircular; forewing with postmarginal vein longer than stigmal (Fig. 103) **ERENCYRTUS** (p. 274)
- Antennal scrobes more or less semicircular and only occasionally reaching more than half way between toruli and anterior ocellus, but if so then postmarginal vein of forewing not longer than stigmal 397
- 397 (396) Gaster dark with basal segment yellow or orange; ovipositor, although not exerted, curved upwards **PROTYNDARICHOIDES** (p. 328)
- Gaster unicolorous, dark, without paler basal segment; ovipositor straight or curved downwards 398
- 398 (397) Eye clothed in short translucent setae, each not longer than diameter of a facet; hypopygium not extending more than two-thirds along gaster; mandible with two teeth and a truncation; forewing with postmarginal vein not longer than stigmal; propodeum medially not more than one-fifth as long as scutellum **SYRPHOPHAGUS** (p. 338)
- Eye clothed in long, occasionally very dense, setae, each clearly longer than a facet; hypopygium almost always reaching apex of gaster or nearly so; mandible with from one to three sharp teeth, never with a truncation; forewing with postmarginal vein sometimes longer than stigmal; propodeum often medially more than one-fifth as long as scutellum 399

Figs 398–411 398, 399, *Paraschedius* spp., (398) right antenna, outer aspect, ♀, (399) right forewing, upper surface, ♀; 400, *Parectromoidella lowelli* (Girault), apex of right forewing venation, upper surface, ♀; 401–406, *Pasulinia gentha* sp. n., (401) right forewing, upper surface, ♀, (402) sculpture in centre of mesoscutum (area approx. 0.1 mm square), ♀, (403) sculpture in centre of scutellum (area approx. 0.1 mm square), ♀, (404) hypopygium, ♀, (405) mid tibia and tarsus, ♀, (406) genitalia, left side, ventral aspect, ♀; 407–410, *Philosindia longicornis* sp. n., (407) right antenna, outer aspect, ♀, (408) genitalia, ventral aspect, left side, ♀, (409) sculpture in centre of mesoscutum (area approx. 0.1 mm square), ♀, (410) sculpture in centre of scutellum (area approx. 0.1 mm square), ♀; 411, *Praleurocerus viridis* (Agarwal), apex of right forewing venation, upper surface, ♀.

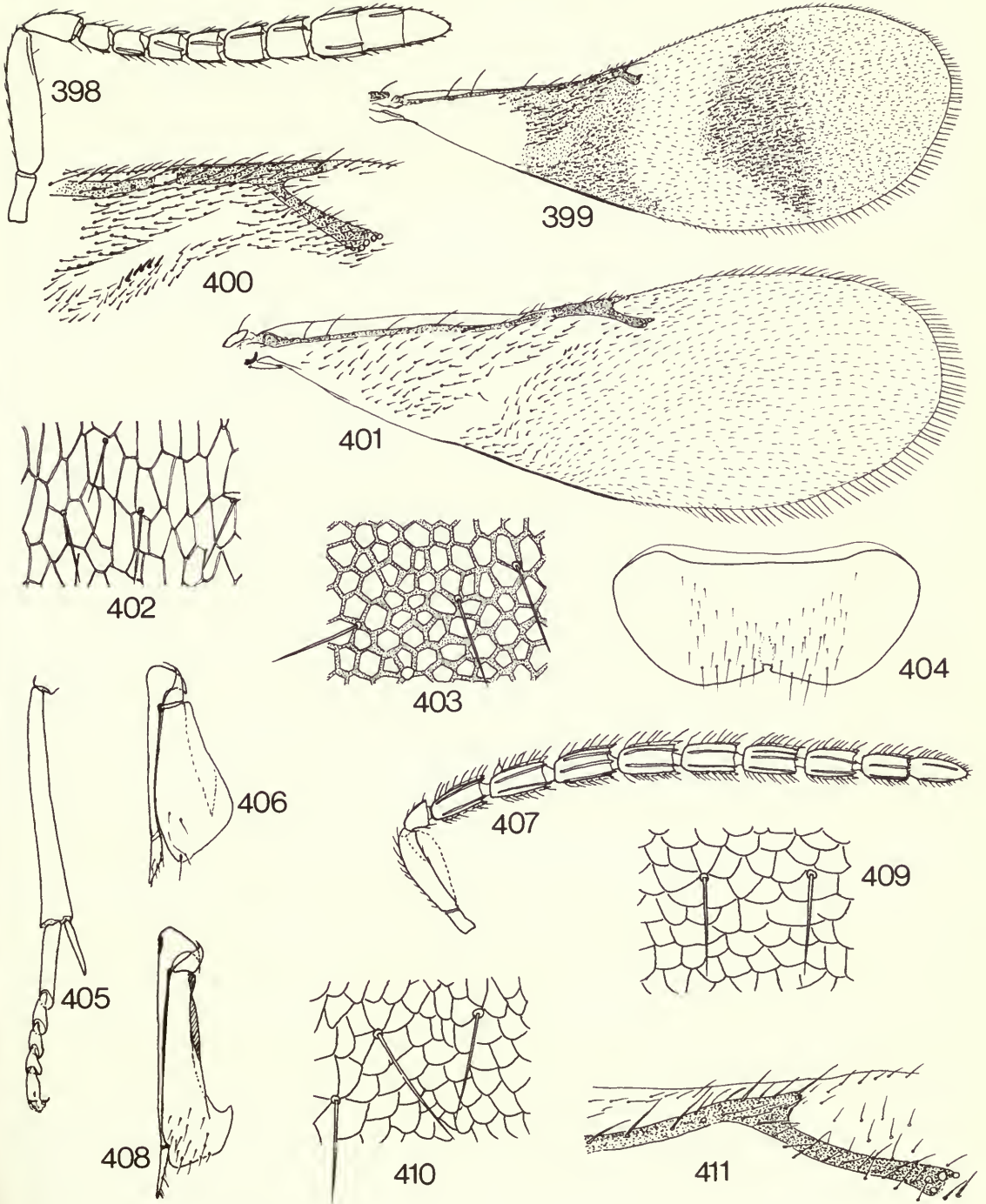

- 399 (398) Ovipositor at least slightly exerted and with sheaths flattened from side to side; gonostyli free and at least one-quarter length of ovipositor (Fig. 430); mandible with three acute teeth (Fig. 144) **TACHINAEPHAGUS** (p. 340)
- Ovipositor not exerted and not visible externally; gonostyli fused to second valvifers (Fig. 415) and not more than one-quarter as long as ovipositor; mandible with one or two teeth **RHYTIDOTHORAX** (p. 333)
- 400 (31) Clava apically obliquely truncate and entire or three-segmented, if three-segmented then outer suture strongly oblique and converging with inner (Figs 205, 211) 401
- Clava apically rounded and two- or three-segmented, sutures more or less parallel 403
- 401 (400) Clava three-segmented (Fig. 205) **PROLEUROCEROIDES** (p. 327)
- Clava entire (Fig. 211) 402
- 402 (401) Scutellum strongly convex and separated from axillae by deep grooves; head and dorsum of thorax with extremely dense, very short, appressed setae; forewing with marginal vein longer than broad **ANANUSIA** (p. 231)
- Scutellum moderately convex and separated from axillae by normal sutures; head and dorsum of thorax with sparse, moderately long erect setae; forewing with marginal vein punctiform (Fig. 212) **TAFTIA** (p. 341)
- 403 (400) Body distinctly dorso-ventrally flattened; clava frequently two-segmented 404
- Body not dorso-ventrally flattened; clava always three-segmented 405
- 404 (403) Exserted part of ovipositor about one-quarter length of gaster with sheaths dark brown and contrasting with remainder of body which is yellow; pronotum clearly visible, entire and triangular in dorsal view and longer than mesoscutum (Fig. 209); head sub-opisthognathous; mandible tridentate; clava two-segmented (Fig. 208) **ASTYMACHUS** (p. 236)
- Ovipositor not exerted; pronotum not clearly visible, obscured by head in dorsal view and longitudinally divided in middle, not triangular in shape (as in Fig. 38) and shorter than mesoscutum; head prognathous; mandible bidentate; clava frequently three-segmented **RHOPUS** (p. 332)
- 405 (403) Forewing with linea calva interrupted in its posterior one-third by at least two lines of setae on dorsal surface of wing (Figs 95, 104), or closed at this point by several lines of setae (Fig. 159) 406
- Forewing with linea calva not interrupted, or if closed then by not more than one line of setae near posterior margin of wing 408
- 406 (405) Forewing with linea calva interrupted in its posterior half (Fig. 104); mandible tridentate; hypopygium not reaching apex of gaster **METAPHYCUS** (p. 298)
- Forewing with linea calva more or less entirely closed in its posterior one-half by setae on dorsal surface of wing; mandible bidentate; hypopygium reaching apex of gaster 407
- 407 (406) Forewing with a distinct pattern of dark and pale setae, stigmal vein long, more than one-quarter length of submarginal vein, marginal vein not quite reaching anterior margin of wing (Fig. 159) **MASHHOODIA** (p. 295)
- Forewing without a distinct pattern of dark and pale setae, stigmal vein less than one-quarter as long as submarginal vein, marginal vein confluent with anterior margin of forewing (Fig. 95) **ANAGYRUS** (p. 229)
- 408 (405) Pronotum triangular in dorsal view, about twice as broad as long and at least about two-thirds as long as mesoscutum (Fig. 149) **CHEILONEURELLA** (p. 248)
- Pronotum very transverse, in dorsal view at least about five times as broad as long and not more than about half as long as mesoscutum 409
- 409 (408) Antennal scrobes deeply impressed and more or less sharply margined laterally; interantennal prominence long, reaching more than half way between antennal toruli and anterior ocellus, sharp at its apex and not confluent with frontovertex (Figs 184, 185) **TACHARDIAEPHAGUS** (p. 340)
- Antennal scrobes shallow to moderately impressed with lateral margins rounded and not well defined; interantennal prominence short, not reaching half way between antennal toruli and anterior ocellus and rounded at its apex, or if longer then confluent with frontovertex 410

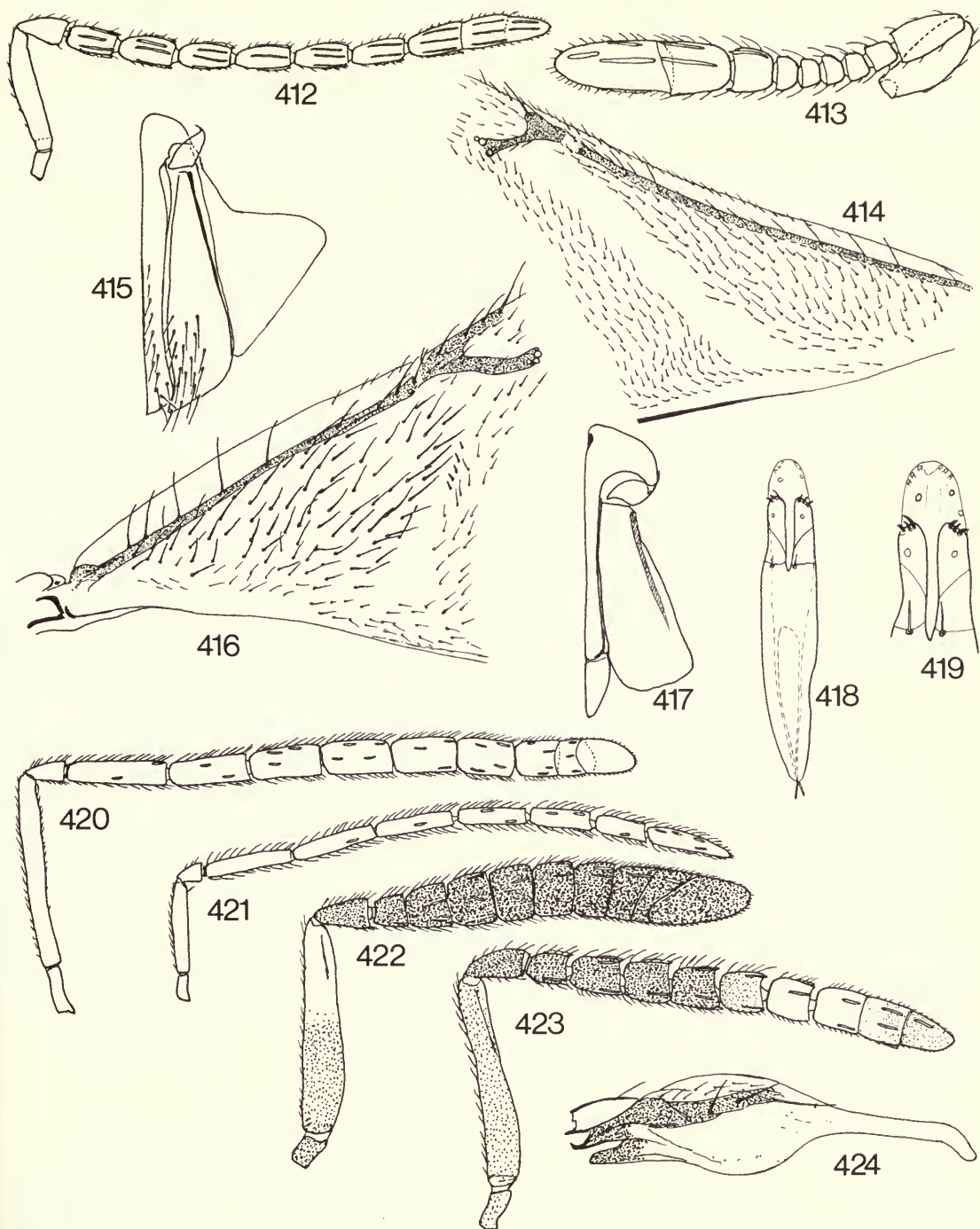

Figs 412–424 412–414, *Rhopus* spp., (412) right antenna, outer aspect, ♀, (413) left antenna, outer aspect, ♀, (414) base of left forewing, upper surface, ♀; 415, *Rhyidothorax* sp., genitalia, left side, ventral aspect, ♀; 416, *Proleuroceroides* sp., base of right forewing, upper surface, ♀; 417–421, *Ruanderoma sankarani* sp. nov., (417) genitalia, left side, ventral aspect, ♀, (418) genitalia, ♂, (419) digits and apex of aedeagus, (420) right antenna, outer aspect, ♀, (421) right antenna, outer aspect, ♂; 422, *Sakencyrtus* sp., right antenna, outer aspect, ♀; 423, 424, *Sakencyrtus* sp., (423) right antenna, outer aspect, ♀, (424) right forewing, upper surface, ♀.

- 410 (409) Eye and frontovertex with very conspicuous dark setae which are subequal in length **APHYCOMORPHA** (p. 233)
 - Eye more or less naked, if setae on eye clearly visible then they are distinctly shorter than those on frontovertex 411
- 411 (410) Body entirely yellow, except for a black spot in centre of pronotum; frontovertex and dorsum of thorax clothed in conspicuous black setae
 - Body generally orange or darker; frontovertex clothed in relatively inconspicuous setae, dorsum of thorax occasionally with conspicuous setae 412
PSYLLAPHYCUS (p. 332)
- 412 (411) Dorsum of thorax and mesopleura largely metallic green **ZARHOPALOIDES** (p. 349)
 - If dorsum of thorax and mesopleura with dark areas then these usually dark brown, but never metallic green 413
- 413 (412) Mesopleurum brown and distinctly darker than dorsum of thorax; mandible with three teeth [*Mesanusia*] **speciosa** Girault (p. 353)
 - Mesopleurum not darker than dorsum of thorax; mandible with two teeth and a truncation 414
- 414 (413) Scape longer than minimum width of frontovertex **NEASTYMACHUS** (p. 304)
 - Scape shorter than minimum width of frontovertex **APHYCOMORPHA** (p. 233)
- 415 (32)** Clava entire (Fig. 108) **TYNDARICOPSIS** (p. 347)
 - Clava three-segmented 416
- 416 (415) Clava much broader than funicle, strongly obliquely truncate and at least as long as funicle; scutellum (excluding axillae) at least a little longer than broad and convex **TYNDARICHUS** (p. 346)
 - Clava apically rounded or occasionally obliquely truncate and shorter than funicle, or if obliquely truncate and longer than funicle then scutellum convex but at least a little broader than long 417
- 417 (416) Propodeum medially at least one-fifth as long as scutellum and usually with some irregular carinae present medially (Fig. 210); occipital margin rounded; triangular expansion of submarginal vein of forewing weak (Fig. 147), forewing often with an elongate wedge-shaped pale fuscous mark from apex; top of antennal toruli at least a little above lower eye margins. . . . **MAHENCYRTUS** (p. 294)
 - Propodeum medially much less than one-sixth as long as scutellum and without carinae (Fig. 206); occipital margin more or less sharp; forewing with triangular expansion of submarginal vein distinct (Fig. 207), forewing completely hyaline; top of antennal toruli below level of lower eye margins
PARECHTHRODRYINUS (p. 319)
- 418 (35)** Either forewing with marginal vein absent (Figs 172, 191) or head with distinct piliferous punctures which are usually not separated by more than their own diameters giving it a thimble-like appearance 419
 - Forewing with marginal vein present; head without deep piliferous punctures . . . 426
- 419 (418) Marginal fringe of forewing absent; clava apically rounded with sutures parallel **HETEROCOCCIDOXENUS** (p. 286)
 - Forewing with marginal fringe present; clava usually obliquely truncate and with sutures oblique and converging 420
- 420 (419) Clava weakly obliquely truncate; first funicle segment almost always at least slightly longer than pedicel, rarely a little shorter 421
 - Clava strongly obliquely truncate; first funicle segment always distinctly shorter than pedicel 423
- 421 (420) Forewing with postmarginal vein not longer than stigmal (Fig. 191) **COWPERIA** (p. 259)

Figs 425–439 425, 426, *Sakencyrtus* sp., (425) right antenna outer aspect, ♀, (426) left forewing, ♀; 427, *Saprencyrtus casuarinae* (Girault), left antenna, outer aspect (from card-mounted specimen), ♀; 428, *Tachinaephagus* sp., right antenna, outer aspect, ♀; 429, *Thomsonisca pakistanensis* (Ahmad), apex of left forewing venation, ♀; 430, *Tachinaephagus* sp., genitalia, left side, ventral aspect, ♀; 431, 432, *Teleterebratus perversus* Compere & Zinna, (431) right antenna, outer aspect, ♀, (432) right mandible, ♀; 433–439, *Tongyus nesus* sp. n., (433) right antenna, outer aspect, ♀, (434) genitalia left side, ♀, (435) hypopygium, ♀, (436) sculpture of frontovertex anterior to anterior ocellus (area approx. 0.1 mm square), ♀, (437) right antenna, outer aspect, ♂, (438) genitalia, ♂, (439) digiti and apex of aedeagus.

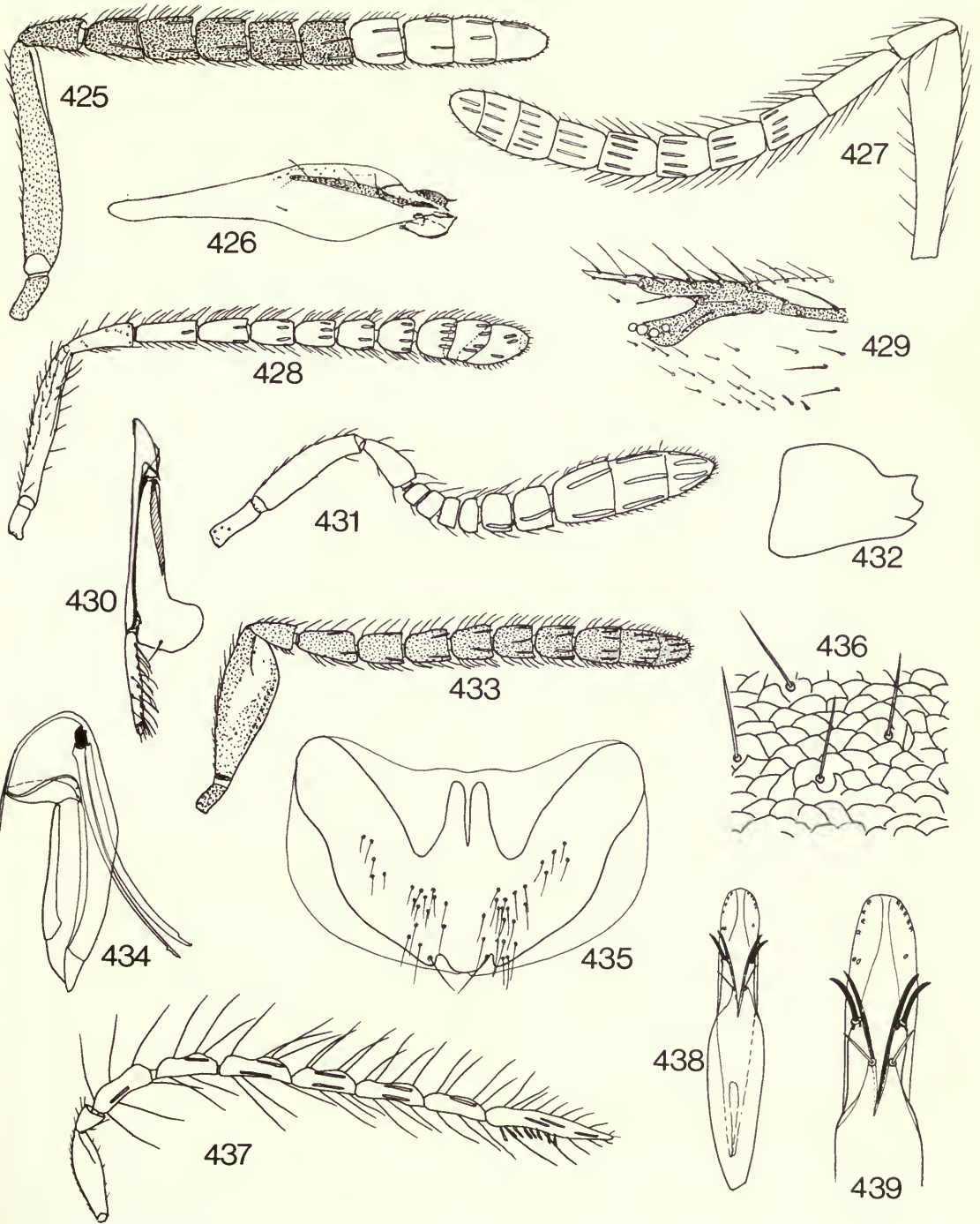

- Forewing with postmarginal vein clearly longer than stigmal 422
- 422 (421) Clava entire **PARACLADDELLA** (p. 315)
- Clava three-segmented **ANAGYRODES** (p. 228)
- 423 (420) Frontovortex narrow, at narrowest point not more than one-quarter head width; antennal scrobes very deep and dorsally sharply margined; mesopleurum enlarged posteriorly and more or less touching basal segment of gaster so that when thorax viewed from side the hind coxa is clearly separated from metapleurum and propodeum by hind margin of mesopleurum (as in Fig. 177) **AMIRA** (p. 228)
- Frontovortex broad, at narrowest point at least one-third head width; antennal scrobes very shallow or absent and not sharply margined; mesopleurum not posteriorly enlarged and clearly separated from first segment of gaster so that when thorax is viewed from side the hind coxa is broadly in contact with metapleurum and propodeum (as in Fig. 140) 424
- 424 (423) Scutellum broad and flat, clearly much broader than long **AMICENCYRTUS** (p. 227)
- Scutellum distinctly convex, at least as long as broad, usually longer 425
- 425 (424) Mesoscutum and scutellum with very deep distinct piliferous punctures which are more or less touching each other and give a thimble-like appearance; propodeum relatively long medially, at least about one-quarter as long as scutellum **BOTHRIOTHORAX** (p. 243)
- Mesoscutum with shallow, very indistinct piliferous punctures, scutellum with raised, closely meshed, reticulate sculpture; propodeum very short, not more than one-tenth as long as scutellum **MENISCOCEPHALUS** (p. 296)
- 426 (418) Forewing with postmarginal vein as long as or longer than stigmal 427
- Forewing with postmarginal vein shorter than stigmal 430
- 427 (426) Clava strongly obliquely truncate and much broader than funicle (Fig. 211); face with a strong transverse carina from below eyes and across top of antennal scrobes **TAFTIA** (p. 341)
- Clava more or less apically rounded and not or hardly broader than funicle; face without a strong transverse carina 428
- 428 (427) Forewing with postmarginal vein clearly much longer than stigmal 429
- Forewing with postmarginal vein about as long as stigmal 430
- 429 (428) Clava entire; mandible long with two very short apical teeth **PARACLADDELLA** (p. 315)
- Clava three-segmented; mandible short and broad with one very small tooth and a broad truncation **PRIONOMASTIX** (p. 325)
- 430 (426, 428) Posterior margin of mesoscutum projecting slightly backwards above axillae so that when thorax is in normal resting position and viewed from above, the axillae appear to be broadly separated (as in Fig. 44); mesopleurum enlarged posteriorly and more or less touching basal segment of gaster so that when thorax viewed from side it clearly separates metapleurum and propodeum from hind coxa (Fig. 177) 431
- Posterior margin of mesoscutum almost straight, not projecting above axillae and so axillae appear to meet medially (as in Fig. 42); mesopleurum not posteriorly enlarged and not touching basal segment of gaster so that when thorax viewed from side the hind coxa touches metapleurum and propodeum (as in Figs 139, 140) 432
- 431 (430) Mesoscutum and scutellum with coarse punctate-reticulate sculpture; mandible bidentate **FULGORIDICIDA** (p. 278)
- Mesoscutum and occasionally also scutellum with shallow reticulate sculpture; mandible with one or two teeth and a truncation or obscurely tridentate **OOENCYRTUS** (p. 309)
- 432 (430) Hypopygium more or less reaching apex of gaster; occipital margin sharp behind eyes; forewing with sensillae at apex of stigmal vein arranged symmetrically in a square, uncus absent (Figs. 142, 183); mandible with three acute teeth **COPIDOSOMA** (p. 257)
- Hypopygium not usually extending more than two-thirds along gaster, although very occasionally nearly reaching apex; occipital margin often more or less rounded, particularly behind eyes; forewing with sensillae at apex of stigmal

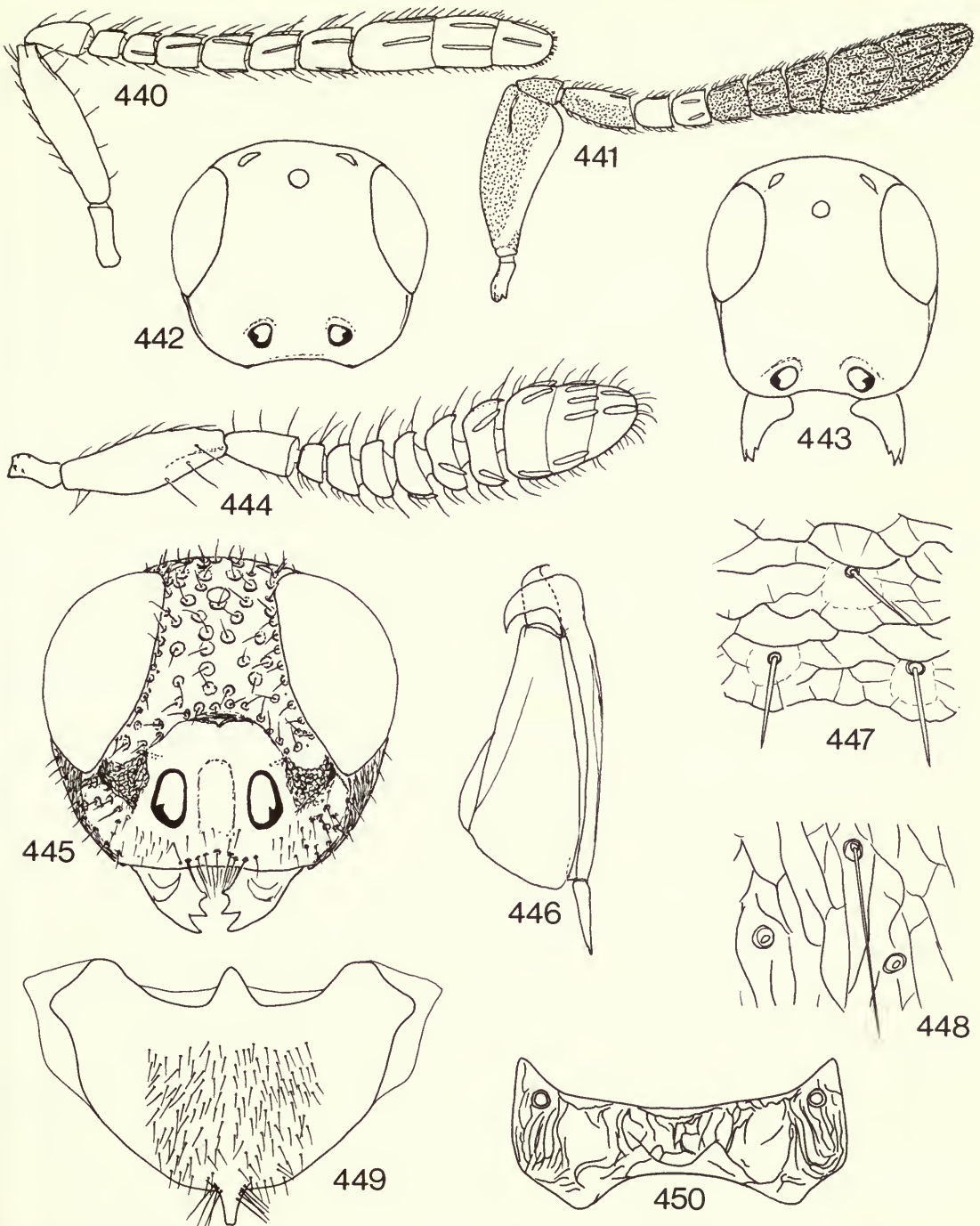

Figs 440–450 440, *Xenostryxis* sp., right antenna, outer aspect, ♀; 441, *Yasumatsuiola* sp., right antenna, outer aspect, ♀; 442–444, *Zaommoencyrtus* spp., (442) head, frontal aspect, ♀, (443) head, frontal aspect, ♀, (444), right antenna, outer aspect, ♀; 445–450, *Zozoros sinemarginis* sp. n., (445) head, frontal aspect, ♀, (446) genitalia, right side, ventral aspect, ♀, (447) sculpture in centre of mesoscutum (area approx. 0.1 mm square), ♀, (448) sculpture in centre of scutellum (area approx. 0.1 mm square), ♀, (449) hypopygium, ♀, (450) propodeum, dorsal aspect showing sculpture, ♀.

- vein arranged asymmetrically and not in a square, uncus present; mandible with one or two teeth and a truncation, or rarely with three teeth 433
- 433 (432) Mandible with one or two teeth and a truncation (Figs 121–122) *PSYLLAEPHAGUS* (p. 330)
- Mandible with three acute teeth (Fig. 178) *PARAENASOMYIA* (p. 316)
- 434 (38) Antennal toruli situated high on head, their lowest margins not or hardly below level of lowest eye margins when head viewed from front (Fig. 113) 435
- Antennal toruli lower on head, their lowest margins well below level of lowest eye margins when head viewed from front 436
- 435 (434) Scape not or hardly longer than malar space; pedicel and funicle segments subequal in size and shape (Fig. 227); posterior ocellus about equidistant from eye and occipital margins, the latter sharp *GAHANIELLA* (p. 278)
- Scape at least twice as long as malar space; pedicel and funicle segments not subequal in size and shape, some at least distinctly narrower or shorter than others; posterior ocellus much closer to eye margin than to occipital margin, the latter more or less rounded *MAYRIDIA* (p. 295)
- 436 (434) Mesopleurum posteriorly enlarged so that it more or less touches basal segment of gaster and when thorax viewed from side it clearly separates hind coxa from metapleurum and propodeum (Fig. 177) 437
- Mesopleurum not so conspicuously enlarged, so that when thorax viewed from side hind coxa more or less broadly touches metapleurum and propodeum and together they clearly separate mesopleurum from basal segment of gaster (as in Figs. 139, 140) 439
- 437 (436) Mandible bidentate; vertex, mesoscutum and scutellum with coarse punctate-reticulate sculpture *FULGORIDICIDA* (p. 278)
- Mandible with one or two teeth and a truncation; at least mesoscutum with relatively shallow sculpture 438
- 438 (437) Forewing with marginal vein less than twice as long as broad (Fig. 152) *OOENCYRTUS* (p. 309)
- Forewing with marginal vein more than twice as long as broad (Fig. 153) *TRICHOMASTHUS* (p. 346)
- 439 (436) Head triangular in profile and strongly inflexed at top of antennal scrobes (Figs 72, 228); mandible with four teeth or one small tooth and a very broad truncation (Figs 116, 229); mesoscutum with dark setae; hypopygium with apex not more than two-thirds along gaster 440
- Head in profile more or less anteriorly evenly rounded, not strongly inflexed at top of antennal scrobes and not triangular, or if slightly so then *either* mandible has three acute teeth and the mesoscutum is clothed in dense white setae *or* the hypopygium reaches or very nearly reaches apex of gaster 441
- 440 (439) Clava more or less apically rounded, not truncate and with sutures more or less parallel; gaster unicolorous and metallic; mandible with four teeth (Fig. 116) *ADELENCYRTUS* (p. 223)
- Clava strongly obliquely truncate with outer suture oblique (Fig. 230); gaster largely yellow or orange; mandible with one small tooth and a very broad truncation (Fig. 229) *PASULINIA* (p. 320)
- 441 (439) Head with very distinct, deep piliferous punctures, these usually shiny-bottomed and contrasting with the relatively dull areas between, each puncture giving rise to a broadened silvery white seta . . . *MENISCOCEPHALUS* (p. 296)
- Either head without deep piliferous punctures, or if punctures deep and conspicuous then they give rise to dark setae and not broadened silvery white setae 422
- 442 (441) Base of gaster at least partly yellow or orange; clava two- or three-segmented and not obliquely truncate 443
- Gaster unicolorous and dark, or if with base yellow then clava entire and strongly obliquely truncate 444
- 443 (442) Forewing with stigmal vein long, at least a little longer than marginal; clava apically rounded; mandible with two teeth and a truncation *DIAPHORENCYRTUS* (p. 263)
- Forewing with stigmal vein short or sessile, distinctly shorter than marginal

- (Figs 231, 232); clava apically rounded or transversely truncate (Figs 233, 234); mandible with three acute teeth **PROTYNDARICHOIDES** (p. 328)
- 444 (442) Hypopygium reaching or very nearly reaching apex of gaster, or if only extending about three-quarters along gaster then clava apically rounded; clava three-segmented 445
- Hypopygium not extending more than two-thirds along gaster, or if slightly more then clava either apically obliquely truncate or solid or two-segmented 451
- 445 (444) Forewing with filum spinosum directed towards junction of submarginal and marginal veins and thus distinctly converging with setae on proximal margin of linea calva (Fig. 127) **CERCHYSIELLA** (p. 246)
- Forewing with filum spinosum more or less directed towards junction of stigmal and marginal veins and thus subparallel to setae on proximal margin of linea calva (Figs 139, 236, 238) 436
- 446 (445) Head and thorax with deep, fine, punctate sculpture; forewing with postmarginal vein longer than stigmal **BLASTOTHRIX** (p. 242)
- Sculpture of head and thorax shallow, although scutellum occasionally has deep reticulate sculpture, of if head and thorax with punctate sculpture then postmarginal vein of forewing not longer than stigmal 447
- 447 (446) Eye clearly overreaching occipital margin **PARECTROMOIDES** (p. 320)
- Eye clearly separated from occiput by occipital margin which is more or less sharp at this point 448
- 448 (447) Eye more or less naked; head and thorax bright metallic green or blue-green **PSYLLAEPHAGUS** (p. 330)
- Eye distinctly hairy; head and thorax usually dull but occasionally metallic 449
- 449 (448) Propodeum medially not more than one-sixth length of scutellum; mandible with two teeth and a truncation, three teeth or four teeth **EXORISTOBIA** (p. 277)
- Propodeum medially at least one-fifth as long as scutellum; mandible with from one to three sharp teeth 450
- 450 (449) Mandible with three acute teeth (Fig. 144); ovipositor usually slightly exerted with sheaths flattened from side to side **TACHINAEPHAGUS** (p. 340)
- Mandible with one or two teeth; ovipositor always hidden and, together with gonostyli, not visible externally **RHYTIDOTHORAX** (p. 333)
- 451 (444) Forewing with postmarginal vein longer than stigmal ... **AUSTROENCYRTOIDEA** (p. 238)
- Forewing with postmarginal vein not longer than stigmal 452
- 452 (451) Clava solid or two-segmented 453
- Clava three-segmented 454
- 453 (452) Mandible with three acute teeth; eye clearly separated from occiput by sharp occipital margin; forewing with sensillae at apex of stigmal vein arranged symmetrically in a square, uncus absent (Figs 142, 183) **COPIDOSOMA** (p. 257)
- Mandible with one or two teeth and a truncation; eye overreaching occipital margin; forewing with sensillae at apex of stigmal vein not arranged in a square, uncus present **ISODROMOIDES** (p. 289)
- 454 (452) Forewing with marginal vein at least three times as long as broad (Figs 186, 192); clava either transversely or obliquely truncate 455
- Forewing with marginal vein only slightly longer than broad, clava apically rounded 456
- 455 (454) Clava with a strong oblique truncation (Fig. 224); scutellum fairly flat with fine, deep, reticulate sculpture which gives it a matt appearance; forewing with marginal vein at least five times as long as broad (Fig. 192); mandible with three acute teeth (Fig. 223) **ECHTHROGONATOPUS** (p. 267)
- Clava with only a slightly oblique, transverse, apical truncation; scutellum slightly convex with shallow, reticulate sculpture and at least slightly shiny; forewing with marginal vein not more than four times as long as broad (Fig. 186); mandible with one or two teeth and a truncation ... **SYRPHOPHAGUS** (p. 353)
- 456 (454) Mandible with three acute teeth (Fig. 178); thorax dull purple-brown with green and coppery reflections **PARAENASOMYIA** (p. 316)
- Mandible with one tooth and a truncation (or occasionally with two teeth and a truncation) (Figs 121, 122); thorax metallic green **PSYLLAEPHAGUS** (p. 330)

457 (39)	Cercal plates in apical half of gaster	458
-	Cercal plates in basal half of gaster	460
458 (457)	Forewing with postmarginal vein shorter than stigmal (Fig. 215); hind tibia strongly oblique at apex (Fig. 216)	<i>MULUENCYRTUS</i> (p. 300)
-	Forewing with postmarginal vein clearly longer than stigmal; hind tibia not strongly oblique at apex	459
459 (458)	Hypopygium reaching or very nearly reaching apex of gaster; mandible with one long, sickle-shaped tooth (or possibly two very short apical teeth giving the mandible a unidentate appearance)	<i>PARALEPTOMASTIX</i> (p. 316)
-	Hypopygium not reaching more than half way along gaster; mandible with three apical teeth	<i>EUCOMOMORPHELLA</i> (p. 276)
460 (457)	Costal cell of forewing with setae evenly distributed over its dorsal surface (Fig. 217); clava entire and apically rounded (Fig. 219); mandible edentate (Fig. 218)	<i>OLYPUSA</i> (p. 307)
-	Forewing with setae on dorsal surface of costal cell restricted to a single line in apical half only; clava two- or three-segmented; mandible with two or three teeth	461
461 (460)	Clava apically rounded; eye not overreaching occipital margin	462
-	Clava with a strong oblique apical truncation; eye reaching occiput	463
462 (461)	Forewing with a complete hyaline fascia distal to venation, marginal vein clearly longer than stigmal (Figs 141, 222); mandible with three acute teeth (Fig. 221)	<i>SAPRENCYRTUS</i> (p. 336)
-	Forewing without a complete hyaline fascia distal to venation, marginal vein shorter than stigmal; mandible with one or two teeth and a truncation (Figs 121, 122)	<i>PSYLLAEPHAGUS</i> (p. 330)
463 (461)	Mesopleurum not posteriorly enlarged and not touching basal segment of gaster so that when thorax viewed from side hind coxa more or less broadly touches metapleurum and propodeum (as in Fig. 140); dorsum of thorax dull and not strongly metallic; clava white contrasting with dark funicle segments (Fig. 137); mandible tridentate	<i>PARENCYRTOMYIA</i> (p. 320)
-	Mesopleurum posteriorly enlarged and more or less touching basal segment of gaster so that when thorax viewed from side it clearly separates hind coxa from metapleurum and propodeum (as in Fig. 177); dorsum of thorax strongly shining purple or blue; flagellum unicolours and dark; mandible with one or two teeth and a truncation (Fig. 71)	<i>PARATETRALOPHIDEA</i> (p. 319)
464 (39)	Forewing with postmarginal vein much longer than stigmal	465
-	Forewing with postmarginal vein not longer than stigmal	466
465 (464)	Propodeum medially not longer than one-fifth length of scutellum; eye more or less naked, setae clearly shorter than diameter of a facet; infuscation of forewing diffuse and not forming a distinct pattern	<i>ENCYRTOIDEA</i> (p. 268)
-	Propodeum medially more than one-fifth as long as scutellum; eye with numerous short setae, each longer than diameter of a facet; infuscation of forewing moderately strong and forming a distinct pattern	<i>BORROWELLA</i> (p. 242)
466 (464)	Mesopleurum with anterior half more or less smooth and shiny and posterior half with distinct, clearly delimited shiny buttopped punctures	<i>PARASTENOTERYS</i> (p. 318)
-	Mesopleurum with similar sculpture in both anterior and posterior halves, usually entirely smooth or nearly so	467
467 (466)	Head and dorsum of thorax with conspicuous piliferous punctures of thimble-like appearance	<i>RHYTIDOTHORAX</i> (p. 333)
-	Head and dorsum of thorax with indistinct, shallow piliferous punctures and not of thimble-like appearance	468
468 (467)	Mesopleurum enlarged posteriorly so that it more or less touches basal segment of gaster so that when thorax viewed from side it separates hind coxa from metapleurum and propodeum (as in Figs 138, 177)	469
-	Mesopleurum not so posteriorly enlarged and not touching basal segment of gaster so that when thorax viewed from side the hind coxa is more or less broadly touching metapleurum and propodeum (as in Figs 139, 140)	471

- 469 (468) Clava not obliquely truncate, truncate surface shorter than ventral surface of clava (Fig. 220) *TRICHOMASTHUS* (p. 346)
- Clava very strongly obliquely truncate, the truncate surface much longer than remainder of ventral surface of clava (Figs 67, 224) 470
- 470 (469) Scutellum smooth and very shiny; forewing with marginal vein not or hardly longer than stigmal (Fig. 68); mandible with two teeth and a very broad truncation (Fig. 225) *OVALOENCYRTUS* (p. 310)
- Scutellum with deep reticulate sculpture; marginal vein of forewing more than twice as long as stigmal (Fig. 192); mandible tridentate (Fig. 223)
ECHTHROGONATOPUS (p. 267)
- 471 (468) Forewing with marginal vein relatively short, not more than twice as long as stigmal 472
- Forewing with marginal vein longer, at least three times as long as stigmal 474
- 472 (471) Clava entire and obliquely truncate at apex *ISODROMOIDES* (p. 289)
- Clava three-segmented and not obliquely truncate (although dorsal surface occasionally more strongly curved than ventral) 473
- 473 (472) Clava with dorsal surface clearly more strongly curved than ventral surface; antennal toruli separated from mouth margin by much more than their own lengths *MAYRIDIA* (p. 295)
- Clava with dorsal surface similarly curved to ventral surface; antennal toruli separated from mouth margin by not more than their own lengths . . . *AENASIELLA* (p. 224)
- 474 (471) Scutellum more or less flat with punctate-reticulate sculpture and matt; forewing with apex of stigmal vein separated from anterior wing margin by less than the maximum depth of uncus *CHEILONEURUS* (p. 249)
- Scutellum clearly convex and with shallow reticulate sculpture and at least slightly shiny; forewing with apex of stigmal vein separated from anterior wing margin by more than maximum depth of uncus (Fig. 226)
HYPERGONATOPUS (p. 288)
- 475 (40) Forewing with marginal vein absent *AMIRA* (p. 228)
- Forewing with marginal vein present 476
- 476 (475) Hypopygium not reaching more than two-thirds along gaster; propodeal spiracle surrounded by dense white setae which continue along sides of propodeum and metapleurum to hind coxa which is also clothed in dense white setae
MENISCOCEPHALUS (p. 296)
- Hypopygium more or less reaching apex of gaster; propodeal spiracle not surrounded by dense white setae, or if so then these do not continue down sides of propodeum and metapleurum to hind coxa 477
- 477 (476) Forewing with filum spinosum directed towards junction of submarginal and marginal veins so that it clearly converges with line of setae on proximal margin of lineal calva (Fig. 127) *CERCHYSIELLA* (p. 246)
- Forewing with filum spinosum absent, margins of lineal calva more or less parallel (Fig. 235) 478
- 478 (477) Frontoververtex at narrowest point about one-quarter head width 479
- Frontoververtex at narrowest point at least one-third head width, usually much wider 480
- 479 (478) Forewing with postmarginal vein longer than stigmal *BLEPYRUS* (p. 242)
- Forewing with postmarginal vein not longer than stigmal *AENASIUS* (p. 225)
- 480 (478) Forewing with marginal vein long, at least half as long as submarginal and at least three times as long as either the short stigmal or postmarginal veins, anterior margin of wing not incised at apex of costal cell (Fig. 237)
METAPHAENODISCUS (p. 297)
- Forewing with marginal vein short, not more than half as long as either postmarginal or stigmal veins and less than one-tenth as long as submarginal vein, anterior margin of wing incised at apex or costal cell (Fig. 235)
CLADISCODES (p. 251)
- 481 (41) Head in profile more or less evenly rounded anteriorly, not triangular; occipital margin sharp; mandible with two or three acute teeth 482
- Head in profile triangular, face strongly inflexed at top of antennal scrobes (as in

- Fig. 72); occipital margin more or less rounded; mandible with one or two teeth and a truncation or four teeth 488
- 482 (481) Clava with a strong oblique truncation (Figs 43, 239, 241) 483
- Clava apically rounded 486
- 483 (482) Hypopygium reaching apex of gaster; forewing with marginal vein absent (Fig. 240); frontovertex at narrowest point broader than length of scape
LUTHERISCA (p. 294)
- Hypopygium not reaching more than two-thirds along gaster; forewing with marginal vein present; frontovertex at narrowest point narrower than length of scape 484
- 484 (483) Forewing with marginal vein not more than twice as long as broad, sensillae at apex of stigmal vein arranged symmetrically in a square, uncus absent (Figs 142, 183, 249) *COPIDOSOMA* (p. 257)
- Forewing with marginal vein at least four times as long as broad, sensillae at apex of stigmal vein not arranged symmetrically and not in a square, uncus present (Fig. 226) 485
- 485 (484) Clava about as long as pedicel and funicle together and darker than funicle, all funicle segments clearly transverse; mesoscutum with sparse white setae; scutellum fairly flat and with distinctly deeper reticulate sculpture than that on mesoscutum; mandible with two teeth and a truncation *BAEOANUSIA* (p. 241)
- Clava not longer than funicle and concolorous; funicle segments subquadrate; mesoscutum with dark setae; scutellum fairly convex and not with deeper sculpture than mesoscutum; mandible tridentate *HYPERGONATOPUS* (p. 288)
- 486 (482) Basal segment of gaster at least dorsally white or yellow and contrasting with the dark remainder of gaster 487
- Gaster unicolorous, dark and shiny, not partly white or yellow 488
- 487 (486) Infuscation of forewing restricted to a subapical fuscous streak (Fig. 245); setae on apical funicle segments normal; mandible tridentate *COAGERUS* (p. 251)
- Infuscation of forewing more extensive with at least a broad complete fuscous fascia from apex of venation; apical funicle segments occasionally with flattened scale-like setae; mandible usually with one or two teeth and a truncation, rarely with three teeth *CHEILONEURUS* (p. 249)
- 488 (481, 486) Forewing strongly infuscate from apical one-third of submarginal vein to apex and enclosing at least three hyaline spots; head with a strong transverse line of dense silvery white setae below eyes and across face below angle of face
EPITETRACNEMUS (p. 273)
- Forewing with infuscation often rather weak and at most with only two hyaline spots in infuscate area; transverse line of setae across face absent or with setae very sparse 489
- 489 (488) Forewing with postmarginal vein clearly much longer than either marginal or stigmal veins, stigmal vein not or hardly shorter than marginal; mandible with two teeth and a truncation, never with four teeth *ADELENCYRTOIDES* (p. 223)
- Forewing with postmarginal vein not or hardly longer than stigmal or marginal veins, stigmal vein usually much shorter than marginal; mandible with two teeth and a truncation or four teeth *ADELENCYRTUS* (p. 223)
- 490 (43) Forewing with venation not reaching anterior margin of wing (Fig. 240); antennal toruli separated from mouth margin by about their own lengths; clava large and with a strong oblique truncation which is twice as long as remainder of ventral surface of clava (Fig. 239); mandible bidentate
LUTHERISCA (p. 294)
- Forewing with venation reaching anterior margin; antennal toruli less than their own lengths from mouth margin; clava usually with apex more or less rounded or transversely truncate, although occasionally with an oblique truncation, but this is only rarely longer than remainder of ventral surface of clava (*Neanagyris* spp.); mandible tridentate or with one or two teeth and a truncation 491
- 491 (490) Forewing with postmarginal vein longer than stigmal *ENCYRTOIDEA* (p. 268)
- Forewing with postmarginal vein not longer than stigmal 492

- 492 (491) First funicle segment anelliform, the remainder subequal and subquadrate; forewing completely naked immediately below marginal vein at top of linea calva **OVIDOENCYRTUS** (p. 312)
- First funicle segment only a little smaller than second, all funicle segments usually gradually enlarging distally; forewing with at least a few setae immediately below marginal vein at top of linea calva 493
- 493 (492) Mandible with one or two teeth and a truncation; apex of hypopygium usually not reaching more than half way along gaster, although occasionally reaching apex 494
- Mandible with three sharp teeth; hypopygium reaching more than half way along gaster and usually to more than five-sixths 496
- 494 (493) Mesopleurum posteriorly enlarged and more or less touching basal segment of gaster so that when thorax viewed from side it clearly separates hind coxa from metapleurum and propodeum (Fig. 177); posterior margin of mesoscutum projecting backwards above axillae so that when thorax in resting position the axillae appear to be broadly separated (as in Fig. 44) **OOENCYRTUS** (p. 309)
- Mesopleurum not posteriorly enlarged and not touching basal segment of gaster, in side view hind coxa more or less broadly touches metapleurum and propodeum (as in Figs 139, 140); median portion of posterior margin of mesoscutum not projecting above axillae so that with thorax in resting position axillae appear to meet (as in Fig. 42) 495
- 495 (494) Clava with a very strong oblique truncation, the surface of which is clearly longer than remainder of ventral surface of clava **NEANAGYRUS** (p. 303)
- Clava with apex more or less rounded **PSYLLAEPHAGUS** (p. 330)
- 496 (493) Antennal toruli separated from mouth margin by at least nearly their own lengths; forewing with sensillae at apex of stigmal vein not arranged in a square, uncus present (Figs 247, 248) 497
- Antennal toruli separated from mouth margin by less than half their own lengths; forewing with sensillae at apex of stigmal vein arranged symmetrically in a square, uncus absent (Figs 142, 183, 249) 498
- 497 (496) Head and thorax bright metallic green with punctate-reticulate sculpture; scape clearly much shorter than minimum width of frontovertex; hypopygium not reaching more than three-quarters along gaster **PARACHALCERINYS** (p. 315)
- Head and thorax often metallic but never bright green, with shallow reticulate sculpture; scape at least about as long as minimum width of frontovertex; hypopygium reaching apex of gaster **COELOPENYRTUS** (p. 255)
- 498 (496) Antennal flagellum not unicolorous, consisting of at least a few white segments contrasting with dark remainder, clava apically transversely truncate **PARALITOMASTIX** (p. 316)
- Antennal flagellum unicolorous; clava usually with rounded apex, although occasionally apically truncate **COPIDOSOMA** (p. 257)
- 499 (44)** Scutellum strongly convex and separated from axillae by deep grooves; face with strong transverse carina above antennal toruli **ANANUSIA** (p. 231)
- Scutellum flat to moderately convex and separated from axillae by normal sutures; face without a strong transverse carina above antennal toruli 500
- 500 (499) Forewing with postmarginal vein at least a little longer than stigmal (Figs 151, 243) 501
- Forewing with postmarginal vein not longer than stigmal 503
- 501 (500) Notaular lines absent; clava longer than funicle; frontovertex not more than one-third head width **EURYRHOPALUS** (p. 277)
- Notaular lines present in anterior part of mesoscutum; clava shorter than funicle; frontovertex at least one-third head width 502
- 502 (501) Forewing with marginal vein longer than stigmal (Fig. 151); malar space less than half as long as eye; sculpture of scutellum more or less same as that on mesoscutum, shallow and reticulate; mandible tridentate ... **PARACLAUSENIA** (p. 316)
- Forewing with marginal vein not longer than stigmal (Fig. 243); malar space longer than half length of eye; scutellum with deep longitudinally elongate

- reticulate sculpture (Fig. 244) which contrasts strongly with the reticulate sculpture of mesoscutum; mandible bidentate **NEOCHARITOPUS** (p. 305)
- 503 (500) Forewing with parastigma clearly swollen (Fig. 242); mandible with two teeth; scutellum distinctly sculptured throughout **COCCIDOXENOIDES** (p. 255)
- Forewing with parastigma not swollen, or if slightly swollen than mandible has three teeth and scutellum has at least apical half smooth and shiny and devoid of sculpture 504
- 504 (503) Face largely green with a contrasting yellow pattern **ZARHOPALOIDES** (p. 349)
- Head either completely yellow or darker and without a contrasting pattern 505
- 505 (504) Scutellum with at least shallow sculpture throughout and without lateral, longitudinal grooves behind axillae; forewing with filum spinosum directed towards junction of marginal and stigmal veins and thus not converging with setae of proximal margin of lineae calva (Figs 248, 249) 506
- Scutellum with at least apical half smooth and shiny and devoid of sculpture and also with a lateral, longitudinal groove behind each axilla; forewing with filum spinosum, if distinct, directed towards junction of submarginal and marginal veins and thus converging with setae of proximal margin of lineae calva (Figs 127, 250, 251) 509
- 506 (505) Hypopygium extending past apex of last tergite and thus clearly visible in dorsal view (similar to Fig. 125); ovipositor slightly exerted and apically slightly downcurved **EPIBLATTICIDA** (p. 272)
- Hypopygium not quite or only just reaching apex of gaster and not visible in dorsal view; ovipositor not exerted, or if so then apex is not downcurved 507
- 507 (506) Clava solid **COPIDOSOMA** (p. 257)
- Clava three-segmented 508
- 508 (507) Frontoververtex very narrow, not more than one-quarter head width; mouth opening small, less than twice as wide as frontoververtex or less than half head width; clava with a distinct oblique apical truncation **TRJAPITZINELLUS** (p. 346)
- Frontoververtex at least one-third as wide as head, or if narrower then mouth opening much wider than frontoververtex or at least about half as wide as head; clava only seldom obliquely truncate **COELOPENECYRTUS** (p. 255)
- 509 (505) Eye relatively small and clearly not reaching occipital margin which is more or less rounded; eye length never more than minimum width of frontoververtex
ZAOMMOENCYRTUS (p. 349)
- Eye larger and more or less reaching occipital margin which is sharp; length of eye greater than minimum width of frontoververtex **CERCHYSIELLA** (p. 246)
- 510 (44) Clava solid with apex rounded **AUSTRALANUSIA** (p. 236)
- Either clava three-segmented or if solid then apex strongly obliquely truncate 511
- 511 (510) Mesopleurum posteriorly enlarged and more or less touching basal segment of gaster so that when thorax viewed from side it clearly separates hind coxa from metapleurum and propodeum (Fig. 177) 512
- Mesopleurum not so enlarged and not touching basal segment of gaster so that when thorax viewed from side hind coxa more or less broadly touches metapleurum and propodeum (as in Figs 139, 140) 515
- 512 (511) Forewing with postmarginal vein clearly longer than either stigmal or marginal veins **ENCYRTOIDEA** (p. 268)
- Forewing with either marginal or stigmal vein longer than postmarginal vein 513
- 513 (511) Forewing with marginal vein not more than twice as long as broad; posterior margin of mesoscutum projecting slightly backwards above axillae so that when thorax in resting position axillae appear to be broadly separated (as in Fig. 44) 514
- Forewing with marginal vein more than twice as long as broad; posterior margin of mesoscutum not projecting above axillae so that axillae more or less touching medially when thorax is in resting position (as in Fig. 42) 515
- 514 (513) Clava very large, much wider than funicle and with a very strong oblique truncation, longer than pedicel and funicle together (Fig. 202)
AGARWALENCYRTUS (p. 226)
- Clava relatively smaller, rarely longer than funicle and apex generally more or

- less rounded, never strongly obliquely truncate (Fig. 246) **OOENCYRTUS** (p. 309)
- 515 (511, 513) Occipital margin more or less rounded, or if appearing sharp then either head triangular in profile, the face strongly inflexed at top of toruli (as in Fig. 72) or forewing with postmarginal vein much more than one-sixth longer than stigmal 516
- Occipital margin sharp; head in profile anteriorly more or less evenly rounded; forewing with postmarginal vein not more than one-sixth longer than stigmal 520
- 516 (515) Mandible with three acute teeth; scutellum slightly convex and at least about as long as broad **ACHALCERINYS** (p. 220)
- Mandible with four teeth or with one or two teeth and a truncation; scutellum usually flat and distinctly broader than long 517
- 517 (516) Either forewing with postmarginal vein longer than stigmal or mandible with four teeth 518
- Forewing with postmarginal vein not longer than stigmal; mandible with one or two teeth and a truncation 519
- 518 (517) Forewing with postmarginal vein clearly much longer than either marginal or stigmal veins, stigmal vein not or hardly shorter than marginal; mandible with two teeth and a truncation **ADELENCYRTOIDES** (p. 223)
- Postmarginal vein of forewing not or hardly longer than either stigmal or marginal veins, stigmal vein usually much shorter than marginal; mandible with four teeth (Fig. 116) **ADELENCYRTUS** (p. 223)
- 519 (517) Forewing with linea calva interrupted on dorsal surface by at least two lines of setae **COCCIDENCYRTUS** (p. 253)
- Forewing with linea calva neither interrupted nor closed on dorsal surface **EPITETRALOPHIDEA** (p. 273)
- 520 (515) Forewing with a distinct hairless streak from apex of postmarginal vein to apex of stigmal vein and extending slightly into disc (Fig. 252) **TASSONIA** (p. 341)
- Forewing without a hairless streak at apex of venation 521
- 521 (520) Mandible with one or two teeth and a truncation 522
- Mandible with three or four sharp teeth, if tridentate then uppermost tooth may be short 527
- 522 (521) Clava with a strong oblique apical truncation, the truncate surface much longer than remainder of ventral surface of clava 523
- Clava without an oblique apical truncation or if so then truncate surface is much shorter than remainder of ventral surface of clava 524
- 523 (522) Forewing with marginal vein at least about four times as long as broad and clearly much longer than stigmal **BAEOANUSIA** (p. 241)
- Forewing with marginal vein only a little longer than broad and less than half as long as stigmal **NEANAGYRUS** (p. 303)
- 524 (522) Setae on eye short and inconspicuous, translucent and not or hardly longer than diameter of a facet 525
- Eye clothed in very long, conspicuous, dark setae, each at least twice as long as diameter of a facet 527
- 525 (524) Forewing with stigmal vein at least nearly three times as long as marginal; head and thorax generally bright metallic green or blue-green **PSYLLAEPHAGUS** (p. 330)
- Forewing with stigmal vein less than twice as long as marginal; head and thorax dark purple-brown with green or brassy reflections, occasionally mesoscutum bright metallic green, but head and scutellum never strongly shiny 526
- 526 (525) Metapleurum clothed with distinct white setae extending to base of hind coxa which is clothed in moderately dense conspicuous setae; base of gaster yellow contrasting with remainder which is dark and shiny **DIAPHORENCYRTUS** (p. 263)
- Metapleurum without any conspicuous white setae; hind coxae with only a few sparse inconspicuous setae; gaster completely dark and shiny without a basal yellow band **SYRPHOPHAGUS** (p. 338)
- 527 (521, 524) Mesoscutum metallic with contrasting white setae; scutellum more or less flat with fine reticulate sculpture giving it a matt appearance which strongly contrasts with metallic colour of mesoscutum; clava strongly obliquely truncate (Fig. 224) **ECHTHROGONATOPUS** (p. 267)

- Mesoscutum with dark setae; scutellum at least slightly convex although occasionally with fine reticulate sculpture which gives it a matt appearance; clava usually more or less rounded, although occasionally with a strong oblique truncation 528
- 528 (527) Eye naked or with very short inconspicuous, translucent setae which are each shorter than the diameter of a facet 529
- Eye clothed in dense conspicuous, pale or dark setae, each at least as long as diameter of a facet 531
- 529 (528) Forewing with sensillae at apex of stigmal vein arranged symmetrically in a square, uncus absent (Figs 142, 183, 249); clava usually solid and with an oblique apical truncation (Fig. 241), although occasionally rounded
- COPIDOSOMA** (p. 257)
- Forewing with sensillae at apex of stigmal vein not arranged in a square, uncus present; clava three-segmented and with apex rounded 530
- 530 (529) Scutellum with deep reticulate sculpture contrasting with shallow sculpture of mesoscutum, latter dull purple and not shiny, scutellum green; mandible with a long middle tooth and very short inner and outer teeth almost appearing unidentate; ovipositor not visible externally **RHYTIDOTHORAX** (p. 333)
- Scutellum with similar sculpture to mesoscutum, both very shiny and metallic; mandible with three short subequal teeth; ovipositor slightly but distinctly exerted **STENOTEROPSIS** (p. 338)
- 531 (528) Scutellum with very shallow reticulate sculpture, almost smooth ... **EXORISTOBIA** (p. 277)
- Scutellum with fine striate-reticulate sculpture (Fig. 254) 532
- 532 (531) All funicle segments transverse (Fig. 253) **HALIGRA** (p. 281)
- Only the first funicle segment not longer than broad, remainder each longer than broad **LAMENNAISIA** (p. 292)

Notes on genera

ACEROPHAGUS Smith

(Key couplets: 62, 66. Fig. 23)

Acerophagus Smith, 1880: 83. Type-species: *Acerophagus coccois* Smith, by monotypy.

Rhopoideus Howard, 1898b: 235. Type-species: *Rhopoideus citrinus* Howard, by monotypy.

DISTRIBUTION AND SPECIES. Sixteen species, New World; three species from review area: *coccois* Smith; Rosen (1969: 57) (Hawaiian Is.), *solidus* Hayat (1981b: 13) (India) and *texanus* (Howard; Rosen, 1969: 63) (Hawaiian Is.).

REFERENCES. World revision: Rosen (1969); see also Beardsley (1976).

BIOLOGY. Parasites of Pseudococcidae (Homoptera).

COMMENTS. *Pseudectroma bryanti* Girault may also run here in the key since it is possible that the clava is entire and not two-segmented. We are retaining it in *Pseudectroma* pending examination of freshly collected material.

Acerophagus is very close to *Pseudaphycus*, *Pseudectroma*, *Indaphycus* (tribe Aphycini, subtribe Aphycina) and possibly also *Mozartella*, from all of which it can be separated using the characters given in the key. It is possibly closest to *Pseudectroma* and can be most reliably separated from this genus by the relatively more narrow frontovertex (see comments under *Pseudectroma*).

ACHALCERINYS Girault

(Key couplet: 516)

Achalcerinys Girault, 1915a: 98. Type-species: *Achalcerinys triclavata* Girault, by original designation.

Echthrobacomyia Girault, 1920d: 142. Type-species: *Echthrobacomyia niveipes* Girault, by monotypy.

Syn. n.

DISTRIBUTION AND SPECIES. Four species, possibly all synonymous, Neotropics (BMNH), Old World including Afrotropical region; all four species from review area: *gorodkovi* (Myartseva, 1983: 66) (**comb. n.** from *Parasyrphophagus*) (India), *lindus* (Mercet, 1921: 271) (**comb. n.** from *Parasyrphophagus*) (India), *niveipes* (Girault, 1920d: 142) (**comb. n.** from *Echthrobaomyia*) (Australia) and *triclavata* Girault (1915a: 98) (Australia), also further undetermined material from S. China and Vietnam to Papua New Guinea and Fiji (BPBM).

BIOLOGY. Unknown.

COMMENTS. The holotypes of *Achalcerinys triclavata* (QM) and *Echthrobaomyia niveipes* (QM) have been examined and certainly are congeneric. They may also be conspecific but there are some slight differences in setation and sculpture of the thorax and in the relative length of the postmarginal vein of the forewing. *Achalcerinys lindus* (Mercet) may also be synonymous. *Achalcerinys gorodkovi* (Myartseva) from Europe and India has dark hind femora, but probably it is merely a colour form of *lindus* since there does not appear to be any consistent morphological difference.

The genus can probably be placed best in the tribe Cheiloneurini. It is superficially similar to *Mahencyrtus* but differs in lacking a strongly expanded parastigma, shorter propodeum and generally much paler legs (the legs of *Achalcerinys* are completely yellow or with the hind femora dark, those of *Mahencyrtus* are usually more extensively darkened). The head also has a characteristic groove connecting the occipital foramen to the centre of the occipital margin behind the ocelli.

ADEKTITOPUS gen. n.

(Key couplets: 242, 264. Figs 148, 160, 161, 255–263)

Type-species: *Adektitopus gordhi* sp. n. Gender: masculine.

♀. *Head.* In facial view a little broader than long, in profile about twice as long as broad and anteriorly gradually curved. Eye with posterior margin very slightly concave, about one-half longer than broad and with numerous fairly conspicuous translucent setae and more or less overreaching occipital margin which is sharp only behind ocelli. Malar space distinctly to a little less than one-third length of eye and with malar sulcus present. Frontoververtex about one-third head width; ocelli approximately forming a right angle, posterior ocellus separated from occipital margin by its own to twice its diameter and from eye margin by a little less than twice its diameter. Antennal scrobes very shallow, meeting or not meeting dorsally and nearly reaching half way to anterior ocellus from antennal toruli; antennal torulus separated from mouth margin by slightly less than its own length and from other torulus by slightly less than to about its own length, its dorsal margin about level with ventral margins of eyes; clypeal margin broadly excised below toruli. Antennal scape cylindrical, much longer than minimum width of frontoververtex, about nine times as long as broad, pedicel conical, about as long as or slightly longer than the funicle segments which are all longer than broad, cylindrical and gradually widening distally; clava three-segmented about half as long as funicle and with apex more or less rounded, outer suture very oblique and strongly converging with inner suture ventrally so that they nearly meet (Figs 255, 256); longitudinal sensillae on all but first one or two flagellar segments. Frontoververtex with moderately deep, raised reticulate sculpture becoming more squamiform on lower parts of face and on interantennal prominence; frontoververtex clothed in sparse, short, translucent setae, occasionally piliferous punctures large and giving the frontoververtex a thimble-like appearance. Mandible with three teeth, the uppermost tooth shortest and blunt, maxillary palpus four-segmented, labial palpus three-segmented.

Thorax. In side view moderately deep with metapleurum and propodeum narrowly in contact with hind coxa, dorsally with both mesoscutum and scutellum convex, almost flat. In dorsal view posterior margin of pronotum quite concave; visible part of mesoscutum about twice as broad as long, with notaular lines present (although in dry-mounted material rather obscure) and reaching about half way across mesoscutum; axillae virtually meeting but appearing separate because posterior margin of mesoscutum projects a little backwards medially; scutellum about as broad as long and about as long as mesoscutum, with apex blunt; propodeum medially about one-quarter to one-fifth as long as scutellum. Mesoscutum with shallow to fairly deep, raised squamiform-reticulate sculpture, scutellum with distinctly deeper, raised, more or less fine vermiculate-reticulate sculpture; propodeum medially quite smooth; mesopleurum almost smooth

but with shallow, raised, reticulate sculpture; dorsum of thorax with numerous, moderately long, translucent, recumbent setae. Forewing hyaline with a faint hint of yellowish or faintly infuscate, wing two and one-half to nearly three times as long as broad; linea calva not interrupted but more or less closed near posterior margin of wing, filum spinosum absent; submarginal vein with an apical hyaline break, with parastigma clearly swollen, much broader than proximal two-thirds of vein, marginal vein about seven to nine times as long as broad, a little longer than postmarginal which is distinctly longer than stigmal; costal cell about 16 times as long as broad and with a single line of setae dorsally in distal half. Hindwing hyaline, about three-quarters as long as forewing, five times as long as broad, with marginal fringe about one-third maximum wing width. Mid tibial spur about as long as basal mid tarsal segment.

Gaster. About as long as thorax, cercal plates in anterior half, paratergites present but membranous, last tergite about two-thirds to three-quarters as long as mid tibia, hypopygium reaching apex of gaster, ovipositor slightly exerted and about as long as to one-third longer than mid tibia, gonostyli more or less free and about one-fifth as long as ovipositor.

♂. Differs from female as follows.

Head. Eye not quite reaching occiput, occipital margin more or less acute. Malar space about half as long as eye; frontovertex nearly two-thirds head width; ocelli relatively larger, posterior ocellus separated from occipital margin by about half its diameter and from eye margin by about its diameter; antennal scrobes reaching more than half way from toruli to anterior ocellus; antennal torulus separated from mouth margin by slightly more than its own length and from other torulus by slightly less, its ventral margin slightly below the ventral margins of the eyes; antennal scape a little shorter than minimum width of frontovertex, cylindrical, about five times as long as broad; pedicel conical, slightly longer than broad, clearly several times shorter than any of the funicle segments which are at least three times as long as broad, setae on flagellum slightly longer than diameter of segments; clava in card-mounted specimens appearing to be entire, but in slide-mounted specimens two-segmented, although suture is incomplete.

Thorax. In side view metapleurum and propodeum broadly in contact with hind coxa; forewing slightly broader, about two and one-half times as long as broad; linea calva open; marginal vein about seven times as long as broad, slightly shorter than postmarginal, both clearly longer than stigmal; costal cell a little more than 20 times as long as broad.

Gaster. Shorter than thorax; genitalia with hooks on the digiti, aedeagus about one-third as long as mid tibia or one-third longer than mid tibial spur.

COMMENTS. The genus belongs to the tribe Charitopidini (Tetracneminae) and can be separated from other genera on the following combination of characters: incomplete notaular lines, sculpture of thorax, lightly infuscate forewings, postmarginal vein longer than stigmal, relatively well-advanced cercal plates and long last tergite, and the unbranched antenna in the male.

The type-species of the genus is named in honour of Dr Gordon Gordh (UCR).

Adektitopus gordhi sp. n.

(Figs 148, 160, 161, 256–263)

♀ Length: 1.24–1.56 mm (holotype, 1.56 mm).

Colour. Head black with faint greenish or bluish metallic sheen, antenna with scape honey yellow with apex slightly darker, pedicel and flagellum from entirely pale brownish yellow to entirely dark brown, the basal segments sometimes paler, clava dark brown; pronotum, axilla and tegula black with a slight purple sheen, mesoscutum dark metallic blue with some purple reflections, scutellum basally dark purple, gradually becoming blue and then green towards the apex; metanotum more or less orange-brown, propodeum and mesopleurum strongly dark metallic purple; fore coxa dark brown with purple reflections, mid coxa basally dark brown, remainder of legs and apex of mid coxa honey yellow; forewing mostly hyaline but with faint yellowish suffusion distal to parastigma, occasionally a faint longitudinal fuscous streak in apical one-half of wing; gaster mostly orange-yellow, the last tergite to a greater or lesser extent dark brown; visible part of gonostyli dark brown.

Head. In profile very slightly less than twice as long as broad; posterior ocellus nearly one and one-half times its own length from occipital margin; antennal scrobes not meeting dorsally; antennal toruli separated from each other by about three-quarters their own lengths; sculpture of frontovertex as in Fig. 258. Relative measurements (holotype): head width (frontal view) 84, head length 75, minimum width of frontovertex 15, malar space 18, eye length 59, eye width 41, POL 14, OOL 2, scape length 49, other proportions of antenna as in Fig. 256.

Thorax. Mesoscutum with shallow, raised, squamiform-reticulate sculpture (Fig. 160); scutellum with much deeper vermiculate-reticulate sculpture (Fig. 161). Relative measurements of forewing (holotype): length 73, width 25, other proportions as in Figs 148, 257; of hindwing: length 57, width 11.

Gaster. Relative lengths (paratype): ovipositor 60, gonostylus 11, last tergite 37, [mid tibia 45]. Hypopygium as in Fig. 259.

♂ Length: 0.87–1.03 mm.

Colour. Head blackish, weakly metallic green, antennal scape testaceous yellow, darker apically; pedicel and flagellum dark brown, apex of pedicel slightly paler; mesoscutum dark brown, weakly metallic green or bluish with some purple reflections; scutellum metallic green; propodeum and mesopleurum dark brown with a purplish sheen; metapleurum slightly yellowish in colour; legs as for female except fore and mid coxae largely yellow; gaster mostly dark brown but ventrally and basally yellowish; forewing very faintly infumate from level with parastigma to apex.

Head. Frontovertex with moderately deep, raised, reticulate sculpture, this becoming shallower and more longitudinally elongate on lower parts of face, particularly genae. Relative measurements (paratype): head width (facial view) 53, head length 47, minimum frontovertex width 30, malar space 13, eye length 28, eye width 20, POL 11, OOL 7, scape length 17, other proportions of antenna as in Fig. 260.

Thorax. Mesoscutum with shallow, raised, reticulate sculpture; scutellum with distinctly deeper (although shallower than in female), raised, reticulate sculpture. Relative measurements (paratype): forewing length 141, forewing width 55, other proportions as in Fig. 261.

Gaster. Relative lengths (paratype): aedeagus 34, [mid tibial spur 26]. Genitalia as in Figs 262, 263.

DISTRIBUTION. India.

BIOLOGY. Unknown.

MATERIAL EXAMINED

Holotype ♀, **India:** Tamil Nadu, Mudumalai Animal Sanctuary, 23–24.x.1979 (*J. S. Noyes*) (BMNH).

Paratypes. **India:** 7 ♀, 3 ♂, same data as holotype; 1 ♀, Maharashtra, Elephanta (caves near Bombay), 28.x.1979 (*M. Hayat*). (BMNH, HC, USNM, ZI, PPRI.)

COMMENTS. A further four species, all from India, can be separated by the female coloration and relative lengths of the antennal segments, general body colour, especially legs and gaster, relative lengths of malar space, length of head in side view, distance of ocelli from occipital margin, whether antennal scrobes meet dorsally, the sculpture of the frontovertex, the relative distance separating the antennal toruli, sculpture of dorsum of thorax, strength of forewing infuscation, relative lengths of ovipositor and last gastral tergite to mid tibia; in the male they may be distinguished by leg coloration and sculpture of the head and thorax.

ADELENCYRTOIDES Tachikawa & Valentine

(Key couplets: 489, 518)

Adelencyrtoides Tachikawa & Valentine, 1969b: 548. Type-species: *Adelencyrtoides novaezealandiae* Tachikawa & Valentine, by original designation.

DISTRIBUTION AND SPECIES. One species *novaezealandiae* Tachikawa & Valentine (1969b: 548) (New Zealand, Chatham I.); possibly also several other species from New Zealand (BMNH, DSIR).

BIOLOGY. Parasites of Diaspididae (Homoptera).

COMMENTS. This genus will be dealt with in more detail in a paper in preparation on the New Zealand Encyrtidae. It may contain several other species but the generic status of most of these is not yet certain and many may be attributable to other, as yet, undescribed genera.

The genus is placed in the tribe Habrolepidini, subtribe Habrolepidina and can be separated from other related genera using the key provided by Tachikawa & Valentine (1969b).

ADELENCYRTUS Ashmead

(Key couplets: 193, 247, 329, 351, 440, 489, 518. Fig. 116)

Adelencyrtus Ashmead, 1900b: 401. Type-species: *Encyrtus chionaspidis* Howard, by original designation.

Epiencyrtoides Girault, 1915a: 108. Type-species: *Epiencyrtoides quadridentatus* Girault, by original designation.

Rotrencyrtus Risbec, 1958: 39. Type-species: *Rotrencyrtus depressus* Risbec, by monotypy.

DISTRIBUTION AND SPECIES. Twenty-five species, cosmopolitan; 19 from review area: *aulacaspidis* (Brèthes; Mercet, 1921: 294) (New Zealand), *axillaris* (Girault, 1915a: 108) (Australia), *bifasciatus* (Ishii; Tachikawa, 1963: 163) (India, Bangladesh, Taiwan, Hawaiian Is.), *bimaculatus* Alam; Hayat *et al.* (1975: 85) (India), *chionaspidis* (Howard; Compere & Annecke, 1961: 52) (Sri Lanka), *clavatus* Hayat, Alam & Agarwal (1975: 83) (India), *coxalis* Hayat, Alam & Agarwal (1975: 78) (India), *funicularis* Hayat, Alam & Agarwal (1975: 80) (India), *longiclavatus* Hayat, Alam & Agarwal (1975: 84) (India), *mayurai* (Subba Rao, 1957: 380) (**comb. n.** from *Anabrolepis*) (India), *minutus* (Girault, 1915a: 177) (**comb. n.** from *Epitetralophidea*) (Australia), *moderatus* (Howard; Noyes, 1979: 144) (Pakistan, India), *oceanicus* (Doutt, 1951: 501) (**comb. n.** from *Anabrolepis*) (Caroline Is., Mariana Is.), *odonaspidis* Fullaway (1913a: 27) (Hawaiian Is.), *quadridentatus* (Girault, 1915a: 108) (Australia), *quadriguttus* (Girault; Hayat, 1978: 33) (**comb. n.** from *Epitetracnemus*) (India), *quinquedentatus* (Girault, 1929a: 3) (**comb. n.** from *Epiencyrtoides*) (Australia), *shafeei* Hayat, Alam & Agarwal (1975: 84) (India), *simmondsi* Compere (1947b: 281) (Australia), also several other unidentified species from throughout the region (BMNH, BPBM, CNC, AMNH).

REFERENCES. Compere & Annecke (1961: 49–58); review of Indian species: Hayat *et al.* (1975: 76–87).

BIOLOGY. Parasites of Diaspididae (Homoptera).

COMMENTS. *Encyrtus solidus* Howard, described from the male sex only, has been incorrectly placed in *Adelencyrtus* (Schmiedeknecht, 1909: 253). The holotype ♂ (USNM) has been examined, but its generic placement remains uncertain.

Two or three undescribed species from the area extending from Borneo and the Philippines to the New Hebrides appear to form a distinct group. This group is characterised by each species being relatively much larger in size (at least about 1.5 mm long), having all antennal segments at least about as long as broad and more deeply infuscate forewings. We do not consider these characters to be sufficient for separate generic status.

The genus belongs to the tribe Habrolepidini, subtribe Habrolepidina (Encyrtinae) and is very closely related to *Epitetracnemus*. The two genera are not at all easy to distinguish and it is our view that further study will show that they should be considered synonymous. However, for the present we are retaining the two as distinct genera, but only on the basis of the presence or absence of a line of silvery setae across the face and the pattern and strength of infuscation of the forewings (see key). We do not consider that the mandibles are reliable in separating the two genera since the difference between a quadridentate mandible and one with two teeth and a truncation is not very great (see Tachikawa, 1963: fig. 70). Head shape also does not appear to be a good character since this can vary significantly. The males of the Habrolepidini all have a two-segmented funicle and a long unsegmented clava and are extremely difficult to separate. A key to females of some of the genera included in this subtribe is also given by Tachikawa & Valentine (1969b).

AENASIELLA Girault

(Key couplets: 142, 204, 473. Fig. 76)

Aenasiella Girault, 1914a: 33. Type-species: *Aenasiella brachyscelidis* Girault, by original designation.

DISTRIBUTION AND SPECIES. Seven species, all Australian: *apiomorphae* Girault (1915a: 80), *australia* Girault (1917b: 35), *brachyscelidis* Girault (1914a: 33), *eucalypti* (Dodds, 1917: 354) (**comb. n.** from *Coccidencyrtus*), *lunulata* (Girault, 1915a: 140) (**comb. n.** from *Coccidoxenus*), *ovi* Girault (1925a: 2) and *sidneyi* (Girault, 1926b: 59) (**comb. n.** from *Encyrtioidea*).

BIOLOGY. Parasites of *Apiomorpha* galls (Homoptera: Eriococcidae) on *Eucalyptus*. Also

recorded as a parasite of eggs of a longicorn beetle (Coleoptera) on *Eucalyptus* but this is possibly incorrect.

COMMENTS. The holotype of *Coccidencyrtus eucalypti* Dodd has not been examined but the description of that species indicates that it must be closely related to *brachyscelidis*.

The genus is very close to *Psyllaephagus* (tribe Trechnitini, subtribe Metaprionomitina) and can virtually only be separated reliably from this genus by having three teeth on the mandible instead of two teeth and a truncation, although the difference here is not always very distinct (compare Figs 75, 76). The marginal vein of the forewing is always clearly longer than broad, whereas in *Psyllaephagus* it is almost always more or less quadrate.

AENASIOIDEA Girault

(Key couplet: 167)

Aenasioidea Girault, 1911: 171. Type-species: *Aenasioidea laticapus* Girault, by original designation.

DISTRIBUTION AND SPECIES. Eleven species, Holarctic, Afrotropical; only one species included here: *aligerhini* (Girault, 1932a: 5) (**comb. n.** from *Aphycus*) (Australia), also one undetermined species reared from *Ceroplastes ceriferus* (Fabricius) from the Philippines (USNM).

REFERENCES. Timberlake (1916: 579–585), Tachikawa (1963: 194–195).

BIOLOGY. Parasites of Kermesidae and Coccidae (Homoptera).

COMMENTS. The genus is extremely close to *Metaphycus* (tribe Aphycini, subtribe Paraphycina) and differs in having the hypopygium reaching the apex of the gaster, the usually relatively long funicle segments and characteristic shape of the ventral margin of the scape.

AENASIUS Walker

(Key couplets: 129, 479)

Aenasius Walker, 1846: 181. Type-species: *Encyrtus hyettus* Walker, by original designation.

Pseudanasius Hayat, Alam & Agarwal, 1975: 21. Type-species: *Pseudanasius clavus* Hayat, Alam & Agarwal, by original designation.

DISTRIBUTION AND SPECIES. Twenty-nine species, mainly New World but also Afrotropical; only one species from this area: *advena* Compere; Kerrich (1967: 207) (Pakistan, India, Bangladesh, Malaysia, Philippines, Solomon Is., New Caledonia, Samoa, Fiji, Loyalty Is., Hawaiian Is.), also one undescribed species from India (BMNH).

REFERENCE. Revision: Kerrich (1967).

BIOLOGY. Parasites of Pseudococcidae (Homoptera).

COMMENTS. The undescribed species from India is intermediate between *Neodiscodes* and *Aenasius*, but we place it in the present genus because of the relatively broader frontovertex (about one-quarter head width).

Trjapitzin (1973) places *Aenasius* in the subtribe Aenasiina of the tribe Rhinoencyrtini which must be incorrect, since *Aenasius* (and thus the Aenasiina) belongs in the Tetracneminæ whilst *Paratetracnemoidea* (= *Rhinoencyrtus*) must belong in the Encyrtinae (see comments under *Paratetracnemoidea*). The subtribe Aenasiina should now be given tribal status, i.e. Aenasiini Kerrich, 1967 (**stat. n.**) since the oldest name previously applied to the group, *Tetralophideina* Erdos & Novicky, 1955 is based on a misidentification of the genus *Tetralophideina* Howard. The tribe Aenasiini thus contains the following genera: *Aenasius*, *Blepyrus* *Chalcaspis*, *Euryrhopalus*, *Metaphaenodiscus*, *Monodiscodes* Hoffer and *Neodiscodes* (Aenasiini = *Neodiscodini* Trjapitzin, 1973 **syn. n.**). *Aenasius* is nearest to *Neodiscodes* and *Chalcaspis* and can best be separated from these genera using Kerrich's key (1967: 188–190), although it is our opinion that further study will show that these three genera should be considered synonymous.

AENASOMYIELLA Girault

(Key couplet: 177)

Aenasomyiella Girault, 1915a: 93. Type-species: *Aenasomyiella coleridgei* Girault, by original designation.

Zaomommoencyrtus Girault, 1917g: 143. Type-species: *Zaomommoencyrtus poeta* Girault, by original designation. **Syn. n.**

DISTRIBUTION AND SPECIES. Three species, all Australian: *cervicincta* Girault (1922e: 151), *coleridgei* Girault (1915a: 93) and *poeta* (Girault, 1917g: 143) (**comb. n.** from *Zaomommoencyrtus*).

BIOLOGY. Doubtfully reared from a psyllid (Homoptera, Psyllidae) nymph under bark of *Eucalyptus*.

COMMENTS. The three species included here are very close but can be separated from each other by the relative position, shape and size of the purple spot on the scape: at apex only – *poeta*; restricted to basal half or so – *coleridgei*; extending from base along ventral margin nearly to apex of scape – *cervicincta*.

The genus is very close to *Metaphycus* (tribe Aphycini, subtribe Paraphycina) and can be separated by the two-segmented clava, relatively shorter scape, i.e. not or hardly longer than the malar space, uninterrupted linea calva and characteristic purplish spot on outer surface of scape.

AGARWALENCYRTUS Hayat

(Key couplets: 393, 514. Figs 202, 203)

Agarwalencyrtus Hayat, 1981b: 15. Type-species: *Coccidencyrtus citri* Agarwal, by original designation.

DISTRIBUTION AND SPECIES. One species, Afrotropical, Oriental and Australasian: *citri* (Agarwal; Hayat, 1981b: 15) (India, Bangladesh, Hong Kong, Java and Solomon Is.), probably a second species from Taiwan (BPBM) which differs from *citri* in the relative position of the ocelli and proportions of the antennal segments.

BIOLOGY. Recorded as a parasite of *Planococcus citri* (Risso) (Homoptera, Pseudococcidae) by Agarwal (1965) but some material (BMNH) reported as being reared from Pipunculidae (Diptera).

COMMENTS. The type-species appears to vary quite considerably in colour, some specimens being almost entirely reddish orange whilst others are almost entirely black. This variation in colour does not appear to be related to distribution.

The genus is probably closely related to *Ooencyrtus* (tribe Microteryni, subtribe Ooencyrtina) and can be easily separated by the relatively large, obliquely truncate clava and strongly transverse funicle segments.

AGENIASPIS Dahlbom

(Key couplet: 188)

Ageniaspis Dahlbom, 1857: 293. Type-species: *Encyrtus fuscicollis* Dalman, by designation of Ashmead (1904c: 303).

Leuroceroides Girault, 1915a: 114. Type-species: *Leuroceroides niger* Girault, by original designation. **Syn. n.**

Microrhopus Girault, 1932b: 1. Type-species: *Microrhopus striatithorax* Girault, by monotypy. **Syn. n.**

DISTRIBUTION AND SPECIES. Nine species, cosmopolitan; three from review area: *citricola* Loginovskaya (1983: 610) (Vietnam), *nigra* (Girault, 1915a: 114) (**comb. n.** from *Leuroceroides*) (Australia) and *striatithorax* (Girault, 1932b: 1) (**comb. n.** from *Microrhopus*), also further undetermined specimens from Papua New Guinea (BPBM).

BIOLOGY. Polyembryonic parasites of larvae of Yponomeutidae (Lepidoptera).

COMMENTS. *Ageniaspis nigra* and *striatithorax* are extremely close and may eventually prove to be synonymous when freshly collected material can be carefully compared with the types of the two species.

In his description of *Microrhopus striatithorax*, Girault did not state that the genus *Microrhopus* was being described as new. It is here taken as an available name since the species epithet is valid (under Article 11g(ii) of the *Code of Zoological Nomenclature*) and the generic name is not unavailable for reasons of homonymy.

Trjapitzin (1973b) places the genus in the subtribe Ageniaspidiina, tribe Copidosomatini. Where their biology is known, all included species are polyembryonic parasites of Lepidoptera. However, further study may show that the Ageniaspidiina are in fact not as closely related to the Copidosomatina as their biology suggests. This is indicated by the difference in forewing venation (notably the arrangement of the sensillae at the apex of the stigmal vein, and the long postmarginal vein) and structure of the gaster (notably the ovipositor). They may in fact be more closely related to the Microteriyini. The subtribe Ageniaspidiina contains three other genera, including *Holcothorax*. *Ageniaspis* can be separated from *Holcothorax* by having a six-segmented funicle (*Holcothorax* has a five-segmented funicle). (See also comments under *Holcothorax*.)

ALAMELLA Agarwal

(Key couplets: 161, 272. Figs 87–88, 167)

Alamella Agarwal, 1966: 74. Type-species: *Alamella flava* Agarwal, by original designation.

DISTRIBUTION AND SPECIES. Two species, Afrotropical and Oriental; one from review area: *flava* Agarwal (1966: 77) (India, Pakistan), also one probably undescribed species from Taiwan (BPBM).

REFERENCES. Anneck (1969: 453–457), Hayat & Verma (1980), Hayat (1981b: 16–17).

BIOLOGY. Parasites of Pseudococcidae (Homoptera); erroneously recorded from Eriococcidae (Homoptera).

COMMENTS. The genus most probably belongs near *Anagyryus* (tribe Anagyryini, subtribe Anagyryina) but can easily be separated from this and related genera by the very distinct structure of the antenna (Fig. 167).

AMENISCOCEPHALUS Girault

(Key couplet: 244)

Ameniscocephalus Girault, 1915a: 167. Type-species: *Ameniscocephalus meniscocephalus* Girault, by original designation.

DISTRIBUTION AND SPECIES. One species, Australian only: *meniscocephalus* Girault (1915b: 167).

BIOLOGY. Unknown, but probably parasitic on Pseudococcidae (Homoptera).

COMMENTS. Almost certainly related to *Metaphaenodiscus* (tribe Aenasiini – see comments under *Aenasius*) but can easily be distinguished on body colour and venation. *Metaphaenodiscus* is dark and metallic with a relatively short stigmal vein and distinct postmarginal vein, whilst *Ameniscocephalus* has a relatively long stigmal vein (subequal to marginal) and the postmarginal vein absent. The venation is very similar to that found in genera near *Paraphaenodiscus*.

AMICENCYRTUS Hayat

(Key couplet: 424. Fig. 265)

Amicencyrtus Hayat, 1981b: 16. Type-species: *Amicencyrtus obscurus* Hayat, by original designation.

DISTRIBUTION AND SPECIES. Afrotropical, Oriental, Australasian, one described species: *obscu-*

rus Hayat (1981b: 17) (India), also undetermined material from Hong Kong, Malaysia, Brunei, Sulawesi, Philippines, Java and Australia (BMNH, BPBM).

BIOLOGY. Unknown.

COMMENTS. Closer examination of the undetermined material may show that it all belongs to *obscurus*. However, there is at least one further undescribed species from the Afrotropical region (BMNH).

The genus is close to *Cowperia* (tribe Bothriothoracini, subtribe Aminellina) from which it can be separated principally by the much flatter thoracic dorsum, particularly the scutellum (that of *Cowperia* is quite convex). Other characters for separating this genus from *Cowperia* are given by Hayat (1981b: 17).

AMIRA Girault

(Key couplets: 423, 475)

Amira Girault, 1913c: 93. Type-species: *Amira fabrei* Girault, by original designation.

Bregmencyrtus Annecke, 1974: 369. Type-species: *Eucomys durantae* Risbec, by original designation.

DISTRIBUTION AND SPECIES. Three species, Afrotropical, Oriental, Australasian; two from review area: *fabrei* Girault; Noyes (1977: 49) (India, Australia) and *tarsata* (Ashmead; 1905b: 403) (comb. n. from *Howardiella*) (Philippines), also undetermined material from India, Borneo and Solomon Is. (BMNH, BMBM).

REFERENCE. Revision: Noyes (1977).

BIOLOGY. Parasites of the eggs of spiders (Araneida).

COMMENTS. The genus has been placed in a separate tribe in the Encyrtinae (Amirini) by Trjapitzin (1973b) but closer examination of material belonging to *Amira*, and its biology, indicate that it is very closely related to *Ooencyrtus* (Microteryini, Ooencyrtina). If this suggested affinity proves to be correct then Amirini Girault, 1913 will have precedence as the valid tribal name over Microteryini Hoffer, 1955. However, the generic relationships within the Encyrtinae are so poorly understood at present that we feel a formal synonymy of these tribal names is premature and probably unnecessary at the present time.

ANAGYRIETTA Ferrière

(Key couplet: 157. Figs 86, 264)

Anagyrietta Ferrière, 1955: 121. Type-species: *Anagyrietta pantherina* Ferrière, by original designation.

DISTRIBUTION AND SPECIES. Palaearctic and Oriental, one species known, but not from review area; one undescribed species from India (BMNH).

BIOLOGY. The type-species has been reared from *Spinococcus calluneti* (Lindinger) (Homoptera, Pseudococcidae) on *Calluna vulgaris*.

COMMENTS. The Indian species differs from the type-species in having the linea calva completely closed (in *pantherina* it is interrupted anteriorly and then closed near posterior margin of wing), the areas of the forewing where the dark setae are situated not infusate as in *pantherina*, notauli completely absent, filum spinosum present (apparently absent in *pantherina*, although we have been unable to examine a slide-mounted forewing). The presence of the filum spinosum is very rare in tetracnemine encyrtids and in particular the Anagyrini. We do not believe that these differences require separate generic status for the Indian species.

ANAGYRODES Girault

(Key couplet: 422)

Anagyrodes Girault, 1915a: 155. Type-species: *Anagyrodes maximus* Girault, by original designation.

DISTRIBUTION AND SPECIES. Oriental and Australasian, seven species: *baethi* Girault (1922b: 103) (Australia), *dei* (Girault, 1922b: 100) (**comb. n.** from *Paracladella*) (Australia), *giganteus* Girault (1915a: 156) (Australia), *maximus* Girault (1915a: 155) (Australia), *odacon* (Walker, 1838b: 476) (**comb. n.** from *Encyrtus*) (Australia), *perkinsi* (Subba Rao, 1971: 212) (**comb. n.** from *Neocladia*) (Australia) and *punctaticeps* Girault (1928b: 449) (Philippines), also undetermined material from India, Papua New Guinea and Borneo (BMNH, BPBM).

BIOLOGY. The unidentified Indian material has been reared from *Batrachomorphus indicus* (Lethierry) nymphs (Homoptera, Cicadellidae).

COMMENTS. The single extant female syntype of *Encyrtus odacon* Walker (BMNH) is here designated LECTOTYPE. This species is very close to *dei* and *perkinsi*.

This genus is related to those placed in the tribes Encyrtini, Eugahaniini, Prionomasticini, Neocladiini and Aethognathini by Trjapitzin (1973b). It is probably closest to *Eugahania* and can easily be separated from this genus in that it lacks the incision at the apex of the costal cell of the forewing. It can be separated from other related genera by the combination of the three-segmented clava, long sickle-shaped mandibular tooth, more or less absent marginal vein of forewing and hypopygium extending to the apex of the gaster or nearly so. Future study may show that these five tribes should be considered synonymous.

ANAGYRUS Howard

(Key couplets: 150, 165, 173, 220, 230, 268, 407. Figs 95, 96, 266–268)

Anagyrus Howard in Howard & Ashmead, 1896: 638. Type-species: *Anagyrus greeni* Howard, by monotypy.

Heterarthrellus Howard, 1898b: 239. Type-species: *Heterarthrellus australiensis* Howard, by monotypy.

Paranusia Brèthes, 1913: 102. Type-species *Paranusia bifasciata* Brèthes, by monotypy.

Philoponectroma Brèthes, 1913: 104. Type-species: *Philoponectroma pectinatum* Brèthes, by original designation.

Gyranusia Brèthes, 1920: 137. Type-species: *Gyranusia porteri* Brèthes, by monotypy.

Gyranusa Mercet, 1921: 123. Type-species: *Gyranusa matritensis* Mercet, by original designation.

Protanagyrus Blanchard, 1940: 115. Type-species: *Protanagyrus aciculatus* Blanchard, by monotypy.

Xiphomastix De Santis, 1972: 45. Type-species: *Xiphomastix bellator* De Santis, by original designation.

DISTRIBUTION AND SPECIES. About 125 species, cosmopolitan; 58 from review area: *adamsoni* Timberlake (1941: 227) (Tahiti), *agraensis* Saraswat in Saraswat & Mukerjee (1975: 41) (India), *alami* Hayat (1970a: 112) (India), *aligarhensis* Agarwal (1965: 52) (India), *almoriensis* Shafee, Alam & Agarwal (1975: 13) (India), *amoenus* Compere (1939: 12) (India), *ananaitis* Gahan (1949: 357) (Hawaiian Is.), *antoninae* Timberlake; Beardsley (1969: 291) (Hawaiian Is.), *australiensis* (Howard, 1898b: 239) (Australia), *bellus* (Girault, 1921b: 190) (**comb. n.** from *Dinocarsis*) (Australia), *citri* Agarwal (1965: 48) (India), *comperei* Subba Rao & Rai (1970: 91) (India), *cooki* (Girault, 1919b: 57) (**comb. n.** from *Dinocarsis*) (Java), *dactylopii* (Howard, 1898b: 242) (India, Hong Kong, Hawaiian Is.), *darevskii* (Trjapitzin, 1965: 310) (**comb. n.** from *Doliphoceras*) (Indonesia), *diversicornis* Mercet (1921: 134) (India), *fasciiscapus* (Girault, 1932b: 1) (**comb. n.** from *Dinocarsis*) (Australia), *ferus* (**nom. n.** for *flavus* Shafee, 1974: 325 nec Ishii, 1928) (India), *flaviceps* Timberlake (1941: 221) (Marquesas Is.), *flavidus* Shafee Alam & Agarwal (1975: 20) (India), *flavimesopleurum* (Girault, 1917g: 137) (**comb. n.** from *Dinocarsis*) (Australia), *foersteri* (Girault, 1915a: 145) (**comb. n.** from *Epidinocarsis*) (Australia), *fusciventris* (Girault, 1915a: 144) (Australia), *greeni* Howard in Howard & Ashmead (1896: 639) (Sri Lanka), *hipocoon* Trjapitzin (1965: 317) (Indonesia), *indicus* (Subba Rao, 1967: 1) (India), *inopus* (**nom. n.** for *indicus* Shafee, Alam & Agarwal, 1975: 13) (India, Mariana Is.), *kivuensis* Compere (1939: 11) (India), *laeviceps* Perkins (1910: 654) (Hawaiian Is.), *lilacini* Ferrière (1937: 317) (Philippines), *lineatipes* (Girault, 1919b: 57) (**comb. n.** from *Dinocarsis*) (Java), *longipennis* Shafee, Alam & Agarwal (1975: 16) (India), *longiventris* Hayat (1979a: 173) (India), *major* Perkins; Beardsley (1969: 289) (Hawaiian Is.), *mirus* (Girault, 1915a: 143) (**comb. n.** from *Epidinocarsis*) (Australia), *mumfordi* Timberlake (1941: 222) (Marquesas Is.), *nigricornis*

Timberlake (1919b: 197) (Hawaiian Is.), *nigricarpus* Shafee, Alam & Agarwal (1975: 11) (India), *nigriflagellum* (Girault, 1915a: 145) (**comb. n.** from *Epidinocarsis*) (Australia), *nigroradiculatus* Subba Rao & Rai (1970: 94) (India), *orbitalis* Timberlake (1941: 220) (Marquesas Is.), *pseudococci* (Girault, 1915a: 185) (Pakistan, India), *punctulatus* Agarwal (1965: 50) (India), *qadrii* (Hayat, Alam & Agarwal, 1975: 12) (**comb. n.** from *Leptanusia*) (India), *saccharicola* Timberlake (1932: 159) (India, Taiwan, Thailand, Malaysia, Philippines, Fiji, Hawaiian Is.), *saipanensis* Doutt (1952: 399) (Mariana Is.), *sawadai* Ishii (1928: 88) (India, Taiwan), *scutomaculatus* Agarwal (1965: 49) (India), *shahidi* Hayat (1979a: 177) (India), *similis* (Girault, 1915a: 145) (**comb. n.** from *Epidinocarsis*) (Australia), *spica* (Girault, 1921b: 191) (**comb. n.** from *Dinocarsis*) (Australia), *subalbipes* Ishii (1928: 90) (S. China), *subflaviceps* (Girault, 1915a: 143) (**comb. n.** from *Epidinocarsis*) (Australia), *subproximus* (Silvestri, 1915b: 346) (Pakistan), *swezeyi* Timberlake (1919b: 199) (Hawaiian Is., India), *tibimaculatus* Agarwal (1965: 50) (India), *varithorax* (Girault, 1923d: 2) (**comb. n.** from *Leptomastix*) (Australia), *xanthogaster* Perkins (1910: 653) (Hawaiian Is.), also much unidentified material from throughout the region (BMNH, BPBM, CNC, UCR, HC).

REFERENCES. Beardsley (1969), Shafee *et al.* (1975: 9–21), Hayat (1979a).

BIOLOGY. Parasites of Pseudococcidae (Homoptera) and Coccinellidae (Coleoptera) from Australia whose larvae produce a waxy secretion, e.g. *Telsimia* sp.

COMMENTS. We have examined a specimen determined as *Mashhoodia flava* by Shafee and believe that it belongs in *Anagyrus*. We have not examined material of *Doliphoceras darevskii*, but from the description it would seem to be better placed in *Anagyrus*.

Anagyrus has been placed in the tribe Anagyrini, subtribe Anagyrina by Trjapitzin (1973a). During our study of the species belonging to genera of this subtribe we have had some measure of difficulty assigning many of the species to genera as they are understood at the present time. Kerrich (1982) has summarised the characters previously used by workers to separate the genera but we have found that the single characters or combinations of characters used by him are largely unreliable, probably because his study was based on only a relatively small number of species belonging to this group. In particular, we have had difficulty in separating *Anagyrus* from *Doliphoceras* and *Gyranusoidea*, and *Epidinocarsis* from *Doliphoceras*, largely because many of the species have unusual combinations of characters, e.g. a species which could be placed in *Doliphoceras* with sculpture typical of *Anagyrus* or a species which could be placed in *Anagyrus* with an elongate postmarginal vein as in *Gyranusoidea*. Our study has not been sufficiently detailed to allow us to reach any satisfactory conclusions with regard to the possible natural grouping of species of this subtribe. We do believe however, that many of the genera included in this group are not necessary and it is very probable that many will be considered synonymous when a more detailed study, on a world-wide basis, is undertaken. Any new genera or generic synonymy proposed at this point could prove to be premature and almost certainly would lead to a good deal of confusion and resentment amongst biological control workers. Therefore we have found it necessary to use simple, convenient characters for separating these genera in the key and, although we do not think that these characters alone will reflect the natural grouping of species, it does allow most of the well-known described species to run in the key to genera where they are placed by most workers at present. *Anagyrus* is here separated from *Doliphoceras* almost solely on sculpture since we find scape coloration, shape of flagellar segments and body shape all totally unreliable. *Gyranusoidea* is separated from *Anagyrus* by the postmarginal vein of the forewing being at least one-quarter longer than the stigmal, whereas in *Anagyrus* it is not or hardly longer. We have not found that sculpture or shape of the scape is totally reliable. Unfortunately this has led to one relatively well-known species being transferred from *Anagyrus* to *Gyranusoidea*, i.e. *mirzai* Agarwal. *Anagyrus* and *Epidinocarsis* are separated entirely on the sculpture of the head and dorsum of thorax as no other characters were found to be reliable. Other genera belonging to this group were separated on characters given in the key.

ANANUSIA Girault

(Key couplets: 370, 402, 499)

Paranusia Girault, 1913e: 97. Type-species: *Paranusia longiscapus* Girault, by original designation. [Homonym of *Paranusia* Brèthes, 1913.]

Ananusia Girault, 1917g: 155. [Replacement name for *Paranusia* Girault.]

Myrmencyrtus Gordh & Trjapitzin, 1979b: 107. Type-species: *Myrmencyrtus australis* Gordh & Trjapitzin, by original designation. **Syn. n.**

DISTRIBUTION AND SPECIES. Two species, both Australian: *australis* (Gordh & Trjapitzin, 1979b: 107) (**comb. n.** from *Myrmencyrtus*) and *longiscapus* (Girault, 1913e: 98).

BIOLOGY. Associated with nests of ants (Hymenoptera, Formicidae) and probably parasitic on mealybugs within the nests (Homoptera, Pseudococcidae).

COMMENTS. We have not seen material of *Myrmencyrtus australis*, but it is clear from the description that it is congeneric with, if not conspecific with, *Ananusia longiscapus*.

The genus is very close to *Taftia* (Chrysoplatygerini) and can easily be separated from it by the extremely deep sutures between the scutellum and the axillae and by the strongly flattened flagellum (in *Taftia* it is more or less cylindrical). A key to separate the genera of the Chrysoplatygerini is given by Gordh & Trjapitzin (1979b).

ANARHOPUS Timberlake

(Key couplet: 55)

Anarhopus Timberlake, 1929: 15. Type-species: *Anarhopus sydneyensis* Timberlake, by original designation.

DISTRIBUTION AND SPECIES. One species, Australasia and New World: *sydneyensis* Timberlake (1929: 18) (= *Arhopoideus semiargenteus* Girault, 1929b: 314 **syn. n.**) (Australia, New Zealand, Hawaiian Is.).

BIOLOGY. Parasites of Pseudococcidae (Homoptera).

COMMENTS. We have not examined the holotype of *A. semiargenteus* (SAM), but since Girault himself, in an unpublished manuscript, synonymised this species with *Anarhopus sydneyensis*, and the description agrees with *sydneyensis*, we have no hesitation in synonymising the two species.

Placed in the tribe Tetracnemini, subtribe Arhopoideina which also includes *Tetracnemoidea* and *Zealandencyrtus* from which it can be separated using the characters given in the key. *Tetracnemoidea* and *Anarhopus* are extremely close and some of the species of *Tetracnemoidea* found in New Zealand appear to be more or less intermediate. A more detailed reevaluation of characters, taking these species into consideration, may eventually show that the two genera should be considered synonymous.

ANICETUS Howard

(Key couplet: 113. Fig. 52)

Anicetus Howard in Howard & Ashmead, 1896: 639. Type-species: *Anicetus ceylonensis* Howard, by monotypy.

Asteropaeus Howard, 1898b: 231. Type-species: *Asteropaeus primus* Howard, by monotypy.

Habrolepopterygis Girault, 1915a: 86. Type-species: *Habrolepopterygis felix* Girault, by original designation.

Krishnieriella Mani, 1935: 421. Type-species: *Krishnieriella ceroplastodis* Mani, by original designation.

DISTRIBUTION AND SPECIES. Twenty-seven species, cosmopolitan except for more northerly latitudes (40°+); 16 species from review area: *aligarhensis* Hayat, Alam & Agarwal (1975: 34) (India), *angustus* Hayat, Alam & Agarwal (1975: 35) (India), *annulatus* Timberlake; Annecke

(1967: 110) (China, Australia, Hawaiian Is.), *ashmeadi* Hayat, Alam & Agarwal (1975: 33) (India), *beneficus* Ishii & Yasumatsu; Tachikawa (1963: 126) (India), *ceylonensis* Howard; Annecke (1967: 108) (India, Sri Lanka), *chinensis* Girault; Annecke (1967: 128), (China), *communis* Annecke (1967: 121) (Australia), *deltoideus* Annecke (1967: 118) (India, China, Borneo), *dodonia* Ferrière; Annecke (1967: 120) (Pakistan, India), *felix* Girault (1915a: 86), (Australia), *howardi* Hayat, Alam & Agarwal (1975: 36) (India), *integrellus* Trjapitzin; Annecke (1967: 129) (Pakistan, India), *mirabilis* (Girault; Annecke, 1971b: 258) (Australia), *stylatus* Subba Rao (1977: 16) (India) and *yasumatsui* Subba Rao (1965: 73) (India), also further undetermined material from throughout the region (BMNH, BPBM, HC).

REFERENCES. Revision: Annecke (1967: 105–130); also Hayat *et al.* (1975: 30–38).

BIOLOGY. Parasites of Coccidae (Homoptera).

COMMENTS. Placed in the tribe Cerapterocerini; *Anicetus* and other genera of this tribe can be separated using the present key and the more detailed one provided by Annecke (1967: 100–101).

ANOMALENCYRTUS Hayat & Verma

(Key couplet: 274. Fig. 169)

Anomalencyrtus Hayat & Verma, 1980: 341. Type-species: *Anomalencyrtus longicornis* Hayat & Verma, by original designation.

DISTRIBUTION AND SPECIES. Afrotropical, Oriental, one described species only: *longicornis* Hayat & Verma (1980: 344) (India).

BIOLOGY. Unknown.

COMMENTS. Material from the Afrotropical region (Zimbabwe – BMNH) almost certainly belongs to the type-species, but differs in having the metanotum, propodeum and mesopleurum extensively dark brown, whereas in the Indian specimens these parts are yellowish.

The genus can best be placed in the tribe Anagyrini, subtribe Anagyrina and differs from all other genera of the subtribe by the peculiar structure of the antenna, notably the long, unsegmented clava.

ANOMALICORNIA Mercet

(Key couplets: 78, 272. Figs 37, 162)

Anomalicornia Mercet, 1921: 85. Type-species: *Anomalicornia tenuicornis* Mercet, by original designation.

DISTRIBUTION AND SPECIES. Palaearctic. Afrotropical, only one species recognised: *tenuicornis* Mercet (1921: 85; also 1922b: 294 as *ruschkai*) (India), also undetermined material from Java and Australia (BMNH, CNC).

BIOLOGY. A parasite of Pseudococcidae (Homoptera).

COMMENTS. More than one species is known to us since material from Cameroun (BMNH) represents an undescribed species. We are not certain that all of the material from India or Australia is actually *tenuicornis* because there are some differences in the relative lengths of the funicle segments.

Trjapitzin (1973a) places this genus in a separate tribe, the Anomalicorniini, but we believe that it could be accommodated in the Anagyrini, possibly as a separate subtribe. The unique structure of the antenna and forewing venation (in fully winged forms) should serve to distinguish this genus from others included in the Anagyrini.

ANTHEMUS Howard

(Key couplet: 45. Figs 12–14)

Anthemus Howard in Howard & Ashmead, 1896: 643. Type-species: *Anthemus chionaspidis* Howard, by monotypy.

Hexalis Bakkendorf, 1939: 84. Type-species: *Hexalis funicularis* Bakkendorf, by monotypy.

DISTRIBUTION AND SPECIES. Ten species, Old World; four from review area: *chionaspidis* Howard in Howard & Ashmead (1896: 643) (Sri Lanka), *inconspicuus* Doutt (1966: 226) (Pakistan), *hilli* Dodd (1917: 352, as var. of *chionaspidis*) (Australia) and *maculatus* Subba Rao (1976: 685) (Pakistan).

REFERENCE. Key to world species: Subba Rao (1976: 685).

BIOLOGY. Parasites of Diaspididae (Homoptera).

COMMENTS. The types of *Anthemus emersoni* Girault (1920b: 98) and *A. nigriceps* Girault (1934a: 2) have been examined (QM). Both belong to the family Mymaridae: *A. emersoni* to a genus very probably near to *Parallelaptera* Enock, and *A. nigriceps* may be a species of *Arescon* Walker.

The genus is the sole representative of the tribe Anthemini (Encyrtinae).

APHYCOMORPHA Timberlake

(Key couplets: 410, 414. Figs 269–271)

Aphycomorpha Timberlake, 1919b: 225. Type-species: *Aphycomorpha araucariae* Timberlake, by original designation.

DISTRIBUTION AND SPECIES. Two species, Neotropics, Pacific and New Zealand: *araucariae* Timberlake (1919b: 227) (Hawaiian Is.) and *aspidioti* Tachikawa & Valentine (1969a: 535) (New Zealand and offshore islands).

BIOLOGY. Parasites of Diaspididae and Eriococcidae (Homoptera).

COMMENTS. *Aphycomorpha aspidioti* (key couplet 414) may be incorrectly placed in this genus and may be closer to *Aphycopsis* since the mesopleurum is not as strongly enlarged as in *araucariae* (see below). It differs from *Aphycopsis australiensis* in biology and in lacking notaular lines on the mesoscutum; however, the latter are very obscure in *australiensis* and this species would run to *Aphycomorpha* (couplet 414) in the key if the notaular lines are overlooked.

The genus has been placed in the tribe Aphycini by Trjapitzin (1973b) but we believe that almost certainly it would be better placed in the Microteriyini. This is indicated by the shape of the mandible (two teeth and a broad truncation) and the enlarged mesopleurum (as in *Ooencyrtus* and *Trichomasthus*, although in *aspidioti* it is not so strongly enlarged) which appears to be typical of most genera which belong in the Microteriyini. It is probably closest to *Aphycopsis* (see comments under *Aphycopsis*) and can be separated from most other genera of the tribe by its resemblance to some species of *Metaphycus* and *Aphycus*.

APHYCOPSIS Timberlake

(Key couplet: 377)

Aphycopsis Timberlake, 1916: 585. Type-species: *Aphycus australiensis* Howard, by original designation.

DISTRIBUTION AND SPECIES. One species, Australia only: *australiensis* (Howard; Timberlake, 1916: 586).

BIOLOGY. Parasites of Pseudococcidae (Homoptera).

COMMENTS. We have examined the two female syntypes of *Aphycus australiensis* Howard

(USNM). One has the head still attached to the body but partially eaten away at the vertex and an antenna and forewing mounted on a slide. The other has the head removed and mounted separately on a slide. The head has been dissected and crushed in typical Girault fashion but is otherwise complete. The latter specimen is here designated as LECTOTYPE and has been so labelled.

Mesanusia speciosa Girault (p. 353) may also belong to this genus.

The genus bears a superficial resemblance to species of *Metaphycus* but differs in the mandible having a single small tooth and a broad truncation (as in Fig. 189) whereas all species of *Metaphycus* have tridentate mandibles. The structure of the mandible and general habitus suggest that the genus is related to *Aphycomorpha* and *Mozartella* which very probably belong in the Microteriyini. It differs from *Aphycomorpha* in having the hind coxa narrowly in contact with the propodeum in side view (see comments under *Aphycomorpha*), forewing with a punctiform marginal vein, and notaular lines present (although very obscure) in the anterior part of the mesoscutum. In *Aphycomorpha* the marginal vein is at least about twice as long as broad and the notaular lines are absent. It differs from *Mozartella* in having a six-segmented funicle and notaular lines present (*Mozartella* has a five-segmented funicle and notaular lines absent).

APHYCUS Mayr

(Key couplets: 362, 364, 388. Figs 199, 272–273)

Aphycus Mayr, 1876: 695. Type-species: *Encyrtus apicalis* Dalman, by designation of Ashmead (1900b: 383).

Aphycoidea Williams, 1916: 153. Type-species: *Aphycoideus io* Williams, by monotypy.

Waterstonia Mercet, 1917c: 268. Type-species: *Waterstonia prima* Mercet, by original designation.

Euaphycus Mercet, 1921: 197. Type-species: *Encyrtus hederaceus* Westwood, by original designation. (As subgenus of *Aphycus*.)

Aphycaspis Hoffer, 1954: 170. Type-species: *Aphycus snoflaki* Hoffer, by original designation. (As subgenus of *Aphycus*.)

DISTRIBUTION AND SPECIES. Twenty-seven species, cosmopolitan except Neotropics; four from review area: *coccidiphagus* Girault (1917g: 134) (Australia), *nassau* Girault (1932a: 4) (Australia), *parisoti* Girault (1936: 1) (Australia) and *rubescens* (Compere & Annecke, 1961: 41) (Taiwan), also several undetermined species from Pakistan, India and Australia (BMNH, BPBM).

BIOLOGY. Parasites of Pseudococcidae (Homoptera).

COMMENTS. One of the Indian species placed here has complete notaular lines and appears to be very close to *snoflaki* Hoffer which is the type-species of subgenus *Aphycaspis*. We have considered the possibility that *Aphycaspis* should be raised to generic status because of the complete notaular lines, but believe that it would be best to defer this until a more detailed study of related genera can be undertaken e.g. *Cirrhencyrtus* Timberlake and *Echthroplexiella* Mercet.

Aphycus is placed in the tribe Aphycini by Trjapitzin (1973b) and almost certainly the tribe should also include *Echthroplexiella* (type-genus of subtribe Echthroplexiellina). (Trjapitzin (1973b) places the subtribe Echthroplexiellina in the tribe Miraini which must be incorrect since *Mira* (type-genus of the Miraini) belongs in the Tetracneminae near the tribe Charitopidini (see also comments under *Mira*.) It is very probable that further study will show that *Echthroplexiella* and *Aphycus* are very close and may even be synonymous since most of the characters used to separate these two genera are unreliable. We also believe that the status of the tribe Homalotylini should be reconsidered because it is very close to the Aphycini and often difficult to separate, even at a subtribal level. The presence or absence of notaular lines is not reliable since many species of *Aphycus*, e.g. *hederaceus* (Westwood), have notaular lines present in the extreme anterior part of the mesoscutum. These are visible on examination of well-cleared specimens using a phase contrast microscope.

APOLEPTOMASTIX Kerrich

(Key couplet: 270. Fig. 166)

Apoleptomastix Kerrich, 1982: 416. Type-species: *Apoleptomastix spoliata* Kerrich, by original designation.

DISTRIBUTION AND SPECIES. Six species, Oriental, Afrotropical and Australasian; five from review area: *bicoloricornis* (Girault; Kerrich, 1982: 427) (Australia), *poonensis* (Mani & Kaul; Kerrich, 1982: 420) (India), *rufipleurus* Kerrich (1982: 421) (India), *rufiscapus* Kerrich (1982: 422) (India) and *spoliata* Kerrich (1982: 424) (Pakistan, India), also at least two further species from India, Bangladesh, Cambodia, Laos, Thailand, Vietnam, China and Hong Kong (BMNH, BPBM, GC).

BIOLOGY. Parasites of Pseudococcidae (Homoptera).

COMMENTS. *A. bicoloricornis* and *spoliata* are extremely close and may be synonymous.

The genus can be placed in the tribe Anagyrini, subtribe Anagyrina (Tetracneminae) and can be separated from related genera by the characters given in the key and also by using the characters listed by Kerrich (1982).

ARRHENOPHAGOIDEA Girault

(Key couplet: 48. Figs 15, 16)

Arrhenophagoidea Girault, 1915a: 73. Type-species: *Arrhenophagoidea coloripes* Girault, by original designation.

DISTRIBUTION AND SPECIES. Four species, Neotropical, Afrotropical and Australasian; one from review area: *coloripes* Girault; Annecke & Prinsloo (1974: 41) (Australia, New Zealand).

REFERENCE. Revision: Annecke & Prinsloo (1974).

BIOLOGY. Parasites of Diaspididae (Homoptera).

COMMENTS. Placed in the tribe Psyllechthriini (Encyrtinae).

ARRHENOPHAGUS Aurivillius

(Key couplet: 45. Figs 9–11)

Arrhenophagus Aurivillius, 1888: 144. Type-species: *Arrhenophagus chionaspidis* Aurivillius, by monotypy.

Mymariella Risbec, 1951: 402. Type-species: *Mymariella parlatoriae* Risbec, by monotypy.

DISTRIBUTION AND SPECIES. Two species, New World, Palaearctic, Afrotropical, Oriental and Pacific; both from review area: *albitibiae* Girault; Annecke & Prinsloo (1974: 38) (Sri Lanka, Hong Kong, China, Hawaiian Is.) and *chionaspidis* Aurivillius; Annecke & Prinsloo (1974: 36) (India, Sri Lanka, New Zealand), also one undetermined species from Samoa (BMNH).

REFERENCE. Revision: Annecke & Prinsloo (1974).

BIOLOGY. Parasites of Diaspididae (Homoptera).

COMMENTS. The only included genus in the tribe Arrhenophagini (Encyrtinae).

ASEIRBA Cameron

(Key couplet: 293)

Aseirba Cameron, 1884: 127. Type-species: *Aseirba caudata* Cameron, by monotypy.

DISTRIBUTION AND SPECIES. One, Neotropical; one undescribed species from Sarawak (BPBM).

BIOLOGY. Unknown.

REFERENCE. Noyes (1980: 179).

COMMENTS. The species from Sarawak differs from *caudata* in having tridentate mandibles, although on one side the third, inner tooth is rather obscure. Having taken into consideration other characters and the size and shape of the mandible we do not consider that this difference is generic. *Aseirba* is very close to *Austroencyrtus* and more or less differs only in having the hypopygium reaching the apex of the gaster, the marginal vein of the forewing relatively shorter, not or hardly longer than broad, whereas in *Austroencyrtus* the hypopygium does not reach more than two-thirds along the gaster and the marginal vein is clearly several times longer than broad. The undescribed Neotropical species previously placed in *Aseirba* (Noyes, 1980: 179) can be better placed in *Austroencyrtus*.

Placement of the genus according to Trjapitzin's (1973*b*) classification is difficult but it may be related to the Bothriothoracini, possibly in an as yet undefined group of genera which would also include *Austroencyrtus* and *Hemileucocerus*. It can be separated from these genera by the characters given in the key.

ASITUS Erdős

(Key couplet: 206. Figs 124, 274–275)

Asitus Erdős, 1955: 47. Type-species: *Asitus ciliatus* Erdős, by original designation.

Ferriereus Ghesquière, 1956: 698. Type-species: *Xanthoencyrtus phragmitis* Ferrière, by original designation.

DISTRIBUTION AND SPECIES. One, Palaearctic and Oriental: *phragmitis* (Ferrière, 1955: 13) (Pakistan).

BIOLOGY. Parasitic on mealybugs associated with *Phragmites* (Homoptera, Pseudococcidae).

COMMENTS. The genus belongs to the subtribe Rhopina (tribe Anagyrini, Tetracneminae) and can be separated from other related genera of the subtribe by having an extremely dorso-ventrally flattened body and a solid clava.

ASTYMACHUS Howard

(Key couplet: 402. Figs 208, 209, 276)

Astymachus Howard, 1898*b*: 238. Type-species: *Astymachus japonicus* Howard, by monotypy.

DISTRIBUTION AND SPECIES. Two, Palaearctic, Oriental; one from review area: *japonicus* Howard; Tachikawa (1963: 160) (India, Pakistan, Malaysia).

BIOLOGY. Reared from Aclerdidae (Homoptera) on sugarcane. Also reported from Pseudococcidae (Homoptera) on sugarcane which is possibly erroneous.

COMMENTS. Placed in the tribe Astymachini by Trjapitzin (1973*b*) as the sole included genus. It is quite possibly related to genera in the tribe Aphycini.

AUSTRALANUSIA Girault

(Key couplets: 185, 510)

Australanusia Girault, 1922*a*: 47. Type-species: *Australanusia pilosithorax* Girault, by monotypy.

DISTRIBUTION AND SPECIES. Two species, both Australian: *pilosithorax* Girault (1922*a*: 47) and *tarsalis* Girault (1923*d*: 2).

BIOLOGY. Unknown.

COMMENTS. The two included species are extremely close and may be synonymous; they appear to differ only in the characters given by Girault (1923*d*: 2).

The genus probably belongs to the tribe Microterytini and should be distinguishable from other genera placed here by Trjapitzin by the combination of the solid clava, transverse funicle segments, very conspicuous hairs on the eyes and dorsum of thorax, and the setae in basal cell of forewing being about as dense of those in centre of wing.

AUSTRALAPHYCUS Girault

(Key couplet: 285)

Australaphycus Girault, 1923*c*: 143. Type-species: *Australaphycus albioviductus* Girault, by monotypy.

DISTRIBUTION AND SPECIES. Australia, one species: *albiovductus* Girault (1923*c*: 143).

BIOLOGY. Unknown.

COMMENTS. Girault, in his description, states 'ovipositor free', which we take to mean that the hypopygium does not extend to near the apex of the gaster. Examination of the holotype (QM) of *albiovductus* shows that the hypopygium appears to reach at least to the apex of the gaster, or perhaps very slightly beyond. However, since the specimen is badly mounted on a microscope slide that may be misleading. The genus appears to be close to *Aenasioidea* (tribe Aphycini, subtribe Paraphycina) and may prove to be synonymous when fresh material is collected.

AUSTRALIA Girault

(Key couplet: 298. Fig. 179)

Australia Girault, 1928*a*: 3. Type-species: *Australia minuta* Girault, by monotypy.

DISTRIBUTION AND SPECIES. One species, Australia only: *minuta* Girault (1928*a*: 3).

BIOLOGY. Unknown.

COMMENTS. This genus possibly also includes *Parachalcerinys coccidoxenoides* Girault from which it can be separated by the relative lengths of the antennal segments.

Australia almost certainly belongs in the tribe Aphycini (Encyrtinae) and can be separated from other genera placed here by the metallic green body, wing venation and conformation of the antennae. Most other genera of the tribe have non-metallic bodies.

AUSTROCHOREIA Girault

(Key couplets: 80, 88)

Chinchilla Girault, 1928*a*: 1. Type-species: *Chinchilla keatsi* Girault, by monotypy. [Homonym of *Chinchilla* Bennett, 1829.] **Syn. n.**

Austrochoreia Girault, 1929*a*: 3. Type-species: *Austrochoreia laticutum* Girault, by monotypy.

Chinchillisca Ghesquière, 1946: 369. [Replacement name for *Chinchilla* Girault.] **Syn. n.**

DISTRIBUTION AND SPECIES. Two described species, both Australian: *keatsi* (Girault, 1928*a*: 1) (**comb. n.** from *Chinchilla*) and *laticutum* Girault (1929*a*: 3), also several other species from Australia and New Zealand (BMNH, DSIR).

BIOLOGY. Unknown.

COMMENTS. Taken in isolation, the two described species appear to exhibit enough morphological differences to warrant retaining the genera they were described in as distinct. *Austrochoreia laticutum* has a very transverse scutellum without a distinct flange apically or laterally and the mesoscutum is slightly exposed posteriorly, whilst *keatsi* has a much longer, more rounded scutellum with a clear flange apically and laterally under which the wing partly fits and the mesoscutum is completely hidden by the pronotum. Other differences, e.g. body size, colour

and relative proportions of the antennal segments, could largely be taken as specific. However, a study of the other material available has shown that the differences in the scutellum and pronotum length are inconsistent and therefore we propose that the two genera be synonymised.

The genus is best placed in the tribe discodini (Encyrtinae) and can be distinguished from other included genera by the elongate pronotum, which largely covers the mesoscutum, the lack of notaular lines and the abbreviated wings.

AUSTROENCYRTOIDEA Girault

(Key couplet: 451)

Austroencyrtoidea Girault, 1922d: 206. Type-species: *Austroencyrtoidea leichhardti* Girault, by monotypy.

DISTRIBUTION AND SPECIES. One species, Australia only: *leichhardti* Girault (1922d: 206).

BIOLOGY. Unknown.

COMMENTS. The genus may belong to the subtribe Syrphophagina (tribe Microteriyini, Encyrtinae) and can be separated from other genera placed there by the combination of the solid clava, elongate postmarginal vein of the forewing and strongly tridentate mandibles. All other genera included in this subtribe have a two- or three-segmented clava, although some occasionally have an elongate postmarginal vein and tridentate mandibles.

AUSTROENCYRTUS Girault

(Key couplet: 293. Fig. 278)

Austroencyrtus Girault, 1923c: 141. Type-species: *Austroencyrtus annulicornis* Girault, by monotypy.

DISTRIBUTION AND SPECIES. Neotropics and Australasia; two species from review area: *annulicornis* Girault (1923c: 141) (Australia) and *guamensis* (Fullaway, 1946: 208) (**comb. n.** from *Cerchysius*) (Mariana Is.), also at least three further undescribed species from Papua New Guinea and New Hebrides (BMNH, BPBM).

BIOLOGY. Associated with Cerambycidae and other beetles (Coleoptera) in rotting logs.

COMMENTS. The genus is near *Aseirba* and *Hemileucocerus* (see comments under *Aseirba*). The holotype of *Cerchysius guamensis* has been examined (USNM) and belongs to the present genus.

AUSTROMIRA Girault

(Key couplet: 261)

Austromira Girault, 1924b: 3. Type-species: *Austromira muironi* Girault, by monotypy.

DISTRIBUTION AND SPECIES. Australia only, one species: *muironi* Girault (1924b: 3) and possibly one other from Australia (BMNH).

BIOLOGY. Unknown.

COMMENTS. Almost certainly related to *Cheiloneurus* (Encyrtinae, tribe Cheiloneurini) and distinguished from other related genera by the lack of an apical tuft of setae on the scutellum, more or less evenly infusate forewings (except apex which is hyaline), pattern of setae on the forewing (a central area just distal to linea calva where the setae are distinctly more sparse than proximal or distal to it, setae in basal cell more or less extending to base of forewing) and coloration and structure of antennae (apical funicle segments and clava white, contrasting with basal segments, and flagellum cylindrical, not conspicuously broadening apically).

AVETIANELLA Trjapitzin

(Key couplet: 182. Figs 105, 106, 277)

Avetianella Trjapitzin, 1968: 97. Type-species: *Avetianella capnodiobia* Trjapitzin, by original designation.

DISTRIBUTION AND SPECIES. Two described species, Holarctic, also Neotropics and Oriental; one undescribed species from India (BMNH).

BIOLOGY. Parasites of eggs of Cerambycidae and Scolytidae (Coleoptera).

COMMENTS. Placed in the tribe Microteriyini, subtribe Oobiina (Encyrtinae). Trjapitzin (1977) provides a key to the genera of this subtribe.

BACALUSA gen. n.

(Key couplets: 240, 277. Figs 165, 173, 174, 279–288)

Type-species: *Bacalusa fuscipennis* sp. n. Gender: feminine.

♀. *Head*. In facial view about as broad as long, or clearly broader than long, in profile about one-half longer than wide and anteriorly more or less gradually and evenly curved. Eye with posterior margin straight, about one-half longer than broad, with a few short inconspicuous setae and reaching occipital margin which is sharp. Malar space a little less than half as long as eye, with malar sulcur present. Frontoververtex slightly less than half width of head; ocelli forming a right angle, posterior ocellus separated from occipital margin by less than to about its own diameter, and from eye margin by its own diameter or a little more. Antennal scrobes moderately deep, but not strongly margined, more or less meeting dorsally and reaching a little more than half way to anterior ocellus from toruli; antennal torulus separated from mouth margin by about its own length and from other torulus by a little less than one and a half times its own length, its dorsal margin slightly below the ventral level of the eyes. Antennal scape more or less cylindrical, about as long as maximum width of frontoververtex, about six times as long as broad, pedicel conical and distinctly longer than any of the funicle segments which are all clearly longer than broad, cylindrical and slightly broadening distally, funicle six-segmented, clava three-segmented, about half to two-thirds as long as, and slightly wider than, the funicle, with apex more or less rounded and sutures parallel; longitudinal sensillae on all but the first two or three flagellar segments. Frontoververtex with very fine, raised, rugose to rugose-reticulate sculpture which may give it a silky appearance, more irregular and elongate on cheeks and more squamiform-reticulate on inter-antennal prominence, numerous short translucent or white recumbent setae on frontoververtex. Mandible narrow with two acute apical teeth, maxillary palpus three-segmented, labial palpus two-segmented.

Thorax. In side view moderately deep and dorsally quite flat with metapleurum and propodeum broadly in contact with hind coxa. Pronotum in dorsal view with hind margin gradually curved and moderately concave; visible part of mesoscutum about twice as broad as long, with notaular lines absent or present in anterior half; axillae meeting; scutellum a little broader than long, slightly longer than visible part of mesoscutum, with apex rounded; propodeum short medially, not more than about one-seventh length of scutellum. Mesoscutum with fine, raised, squamiform-reticulate sculpture, scutellum with similar but rather more longitudinally elongate sculpture, both mesoscutum and scutellum often having an almost silky appearance, propodeum with or without shallow, raised sculpture medially, mesopleurum with shallow raised reticulate sculpture; dorsum of thorax with numerous short, appressed, translucent setae. Forewing hyaline or with a distinct fuscous pattern, wing from about two and one half to a little less than three times as long as broad, lineae calva interrupted or closed by about three lines of setae, filum spinosum absent, submarginal vein with an apical hyaline break, marginal vein about twice as long as broad, about as long as or longer than postmarginal and slightly shorter than stigmal, costal cell relatively narrow, over 18 times as long as broad and with a single line of setae dorsally in distal half. Hindwing hyaline, about five to six and one-half times as long as broad with marginal fringe about two-thirds maximum wing width. Mid tibial spur a little shorter than basal mid tarsal segment.

Gaster. About as long as thorax, cercal plates in anterior half, paratergites present, last tergite from only a little longer than half length of to as long as mid tibia, hypopygium reaching apex of gaster, ovipositor very slightly exerted and about two-thirds length of mid tibia, gonostyli fused to second valvifers and about one-sixth length of ovipositor.

♂. Differs from female as follows.

Head. Malar space at least about two-thirds length of eye; frontoververtex clearly broader than half head

width, posterior ocellus separated from occipital margin by less than its own diameter and from eye margin by a little less than twice its diameter; antennal scrobes absent; antennal torulus separated from mouth margin by about twice its own length and from other torulus by about its own length, its ventral margin slightly below to well above the ventral margins of the eyes; antennal scape about as long as to distinctly shorter than width of frontovertex, pedicel short, a little longer than broad and about half as long as any of the funicle segments which are at least about twice as long as broad; longest setae on funicle about four times as long as maximum width of segments, longitudinal sensillae on all flagellar segments but the first one or two, scale-like sensillae in distal half of sixth funicle segment or proximal half of clava. Sculpture of head similar to that of female but less silky in appearance.

Thorax. Similar to that of female, except if infuscation of forewing present then less strong than in corresponding females and sculpture of dorsum of thorax less fine and lacking silky appearance.

Gaster. Similar to female except cercal plates of distal half of gaster and genitalia: *digiti* about one-quarter to one-eighth length of aedeagus which in turn is a little less than half as long as mid tibia or about twice as long as mid tibial spur.

COMMENTS. The genus belongs to the tribe Anagyrini, subtribe Anagyrina (Tetracneminae). It can be distinguished from other members of the subtribe by the conformation of the antenna, the occasional presence of notaular lines on the mesoscutum and infuscation of the forewing.

Bacalusa fuscipennis sp. n.

(Figs 165, 174, 279–288)

♀. Length: approx. 0.78–0.81 mm (holotype, 0.81 mm).

Colour. Head orange, antenna yellow with basal half of scape and apex of clava slightly dusky, thorax and gaster dark orange, distinctly dusky in centre and anterior margin of mesoscutum, apex of tegula, along midline of scutellum, sides of propodeum immediately above hind coxa and on gaster immediately distad of cercal plates, legs yellow; infuscation of forewing as in Fig. 279.

Head. Frontovertex above scrobes with very fine, raised, transversely rugose-reticulate sculpture of moderately silky appearance (Fig. 280), lower parts of face and interantennal prominence with more squamiform-reticulate sculpture; posterior ocellus separated from occipital margin by a little more than half its own length and from eye margin by about one and one-half times its own length. Relative measurements (holotype): head width (facial view) 55, head length 55, minimum frontovertex width 26, malar space 17, eye length 34, eye width 23, POL 8, OOL 6, scape length 30, other proportions of antenna as in Fig. 174.

Thorax. Notaular lines present and reaching slightly more than half way across mesoscutum; mesoscutum with fine, raised, squamiform-reticulate sculpture (Fig. 281), that on scutellum similar but laterally more longitudinally elongate (Fig. 282), both mesoscutum and scutellum distinctly less silky in appearance than frontovertex and with only a few appressed, translucent setae. Relative measurements of forewing (holotype): length 129, width 42, other proportions as in Figs 165, 279; of hindwing: length 100, width 15.

Gaster. Relative lengths (paratype): ovipositor 68, gonostylus approx. 10, last tergite 60, [mid tibia 105]. Ovipositor Fig. 283, hypopygium Fig. 284.

♂. Length: approx. 0.75 mm.

Similar to female except following. Coloration slightly darker and infuscation of forewing distinctly paler. Antennal toruli with their lower margins clearly a little above ventral margins of eyes (Fig. 285), otherwise differs from female as in generic description. Relative measurements (paratype): minimum frontovertex width 36, head width 63, scape length 35, proportions of antenna as in Fig. 286; aedeagus length 31, length mid tibial spur 14, genitalia as in Figs 287, 288.

DISTRIBUTION. India.

BIOLOGY. Unknown.

MATERIAL EXAMINED

Holotype ♀, **India:** Tamil Nadu, 3 km E. Manjaler Dam, 15–18.x.1979 (*J. S. Noyes*) (BMNH).

Paratypes. **India:** 1 ♀, 1 ♂, same data as holotype (BMNH).

COMMENTS. We consider that *Doliphoceras tachikawai* Shafee, Alam & Agarwal (1975: 26) also belongs to this genus (**comb. n.**). It differs from *fuscipennis* in coloration, hyaline forewings and lack of notaular lines. There is also a possible third species which appears to be distinguishable

from *fuscipennis* in having the mesoscutum and scutellum more silky in appearance and more dense, white, appressed setae, the subapical fuscous marking of the forewing more oblique and the body coloration of the female generally more reddish or orange. This third species has been found in India and Zimbabwe (BMNH), but may only be a form of *fuscipennis*.

BACHIANA Girault

(Key couplet: 368)

Bachiana Girault, 1940: 149. Type-species: *Bachiana curiosa* Girault, by monotypy.

DISTRIBUTION AND SPECIES. One species, Australia only: *curiosa* Girault (1940: 149).

BIOLOGY. Parasites of Diaspididae (Homoptera).

COMMENTS. Placement of the genus is difficult because the type-material is in poor condition. However, the mandible (one tooth and a truncation) and wing venation suggest that it could be placed in the Microteriyini (Encyrtinae). It is possibly related to the genera placed in the subtribe Syrphophagina and can be easily separated from these by having an anelliform first funicle segment, interrupted linea calva and by the shape of the mandible. Girault's unpublished manuscript (QM) states that the clava is entire, but the only clava located on either of the two slides containing syntypes appears to be two-segmented. There appear to be no intact female antennae on either of these slides. (See also comments under *Coccidoctonus*.)

BAEOANUSIA Girault

(Key couplets: 203, 485, 523)

Baeoanusia Girault, 1915a: 163. Type-species: *Baeoanusia magniclava* Girault, by original designation.

DISTRIBUTION AND SPECIES. Australia only, three species: *albifunicle* Girault (1932a: 3), *magniclava* Girault (1915a: 164) and *persimilis* Girault (1915a: 164).

BIOLOGY. Unknown. However, *albifunicle* (which is misplaced in this genus, see below) has been reared from the eggs of *Paropsis* sp. (Coleoptera, Chrysomelidae) (Riek, 1962c).

COMMENTS. *Baeoanusia albifunicle* is misplaced in this genus, appearing to be intermediate between *Mesanusia* and *Baeoanusia* and, in some respects, has some resemblance to a large species of *Zaomma*. Almost certainly a new genus is required to accommodate it. However, since the species can be reasonably well placed in *Baeoanusia*, we feel that a new genus is unnecessary at the present time, at least until fresh material becomes available and the relationships between these genera can be studied in more detail.

The genus belongs to the tribe Cheiloneurini (Encyrtinae) and is closest to *Neblatticida* from which it can be separated by having hyaline wings, whilst *Neblatticida* has infusate wings. A more detailed study of fresh material may indicate that the two genera should be considered synonymous. *Baeoanusia* can be separated from other members of the tribe by having finely punctate sculpture on the head and dorsum of the thorax (as in *Blastothrix*) and a large antennal clava, and lacking an apical tuft of setae on the scutellum.

BEETHOVENA Girault

(Key couplet: 64)

Beethovena Girault, 1932a: 3. Type-species: *Beethovena longifasciata* Girault, my monotypy.

DISTRIBUTION AND SPECIES. One species, Australia only: *longifasciata* Girault (1932a: 2).

BIOLOGY. Unknown.

COMMENTS. The genus is very close to *Metaphycus* (Aphycini, subtribe Paraphycina) from which it can be separated by having a five-segmented funicle, whilst *Metaphycus* has a six-segmented funicle.

BLASTOTHRIX Mayr

(Key couplets: 209, 446)

Blastothrix Mayr, 1876: 697. Type-species: *Encyrtus sericeus* Dalman, by designation of Ashmead (1900b: 389).

DISTRIBUTION AND SPECIES. Twenty-seven species, Holarctic, Afrotropical, Oriental; three species from review area: *britannica* Girault; Sugonjaev (1964: 382) (Pakistan), *sericea* (Dalman; Sugonjaev, 1964: 381) (Pakistan, India) and *siddiqii* (Bhatnagar, 1952: 167) (**comb. n.** from *Encyrtus*) (India), also one undetermined species from India (BMNH).

REFERENCE. Revision of Palaearctic species: Sugonjaev (1964).

BIOLOGY. Parasites of Coccidae and possibly also Kermesidae (Homoptera).

COMMENTS. We have not seen the holotype of *Encyrtus siddiqii* but from the description of the species and the host record we feel certain that it belongs in *Blastothrix*.

Trjapitzin (1973b) places the genus in the tribe Aphycini (subtribe Blastothrichina) which we believe may be incorrect since it appears to be closely related to *Psyllaephagus*. The latter is placed in the tribe Trechnitini, subtribe Metaprimonitina. The subtribe Blastothrichina should probably be transferred from the Aphycini to the Trechnitini, but we do not formally propose this since it is beyond the scope of the present work. *Blastothrix* is recognisable by the metallic green or blue-green colour, deep punctate sculpture of the head and thorax, the mandible having one tooth and a broad truncation, and the forewing with a marginal vein at least three times as long as broad.

BLEPYRUS Howard

(Key couplet: 479)

Blepyrus Howard, 1898b: 233. Type-species: *Blepyrus mexicanus* Howard, by designation of Ashmead (1900b: 373).

Coccophoctonus Ashmead, 1900b: 375. Type-species: *Coccophoctonus dactylopii* Ashmead, by original designation.

DISTRIBUTION AND SPECIES. Three species, circumtropical; one from review area: *insularis* (Cameron; Kerrich, 1967: 226) found throughout the area except New Zealand.

REFERENCE. Revision: Kerrich (1967: 225–228).

BIOLOGY. Parasites of Pseudococcidae (Homoptera).

COMMENTS. The genus is a member of the tribe Aenasiini (see comments under *Aenasius*). It can be separated from other related genera by the characters given in the key, notably the stigmal vein of the forewing being clearly shorter than the postmarginal and the relatively wide frontovertex. Kerrich (1967: 188–190) also provides a key to most of the genera of the tribe.

BORROWELLA Girault

(Key couplets: 359, 465)

Borrowella Girault, 1923b: 99. Type-species: *Borrowella bioculata* Girault, by monotypy.

DISTRIBUTION AND SPECIES. Australia only; two species: *bioculata* Girault (1923b: 99) (= *Borrowella consobrina* Girault, 1923d: 2 **syn. n.**) and *punctatinotum* Girault (1923b: 100); possibly also one further species near *punctatinotum* but with the ovipositor less exerted.

BIOLOGY. Unknown.

COMMENTS. *Borrowella consobrina* appears to be a colour form of *bioculata* and the two are therefore regarded as synonymous.

The genus probably belongs in the tribe Bothriothoracini. It can be separated from other

members of the tribe principally by the darkened forewing and the postmarginal vein being longer than the stigmal.

BOTHRIOPHYNE Compere

(Key couplet: 282)

Bothriophryne Compere, 1937: 45. Type-species: *Bothriophryne ceroplastae* Compere, by original designation.

DISTRIBUTION AND SPECIES. Seven species, Afrotropical; none from review area but two undescribed species from India (Agarwal *et al.*, 1980: 30).

REFERENCE. Prinsloo & Annecke (1978*b*: 323–325).

BIOLOGY. Parasites of Coccidae (Homoptera).

COMMENTS. The genus is close to *Trichomasthus* (Microteriyini, subtribe Microteriyina) and is most easily separated by having the antennal toruli relatively high on the head, their lowest margins at or above the level of the lowest eye margins (in *Trichomasthus* they are well below), and the marginal vein of forewing punctiform (in *Trichomasthus* it is generally much longer than broad).

BOTHRIOTHORAX Ratzeburg

(Key couplet: 425)

Bothriothorax Ratzeburg, 1844: 209. Type-species: *Bothriothorax altensteinii* Ratzeburg, by monotypy.
Trimorphocerus Dahlbom, 1857: 292. Type-species: *Bothriothorax altensteinii* Ratzeburg, by designation of Gahan & Fagan (1923: 149).

DISTRIBUTION AND SPECIES. Thirty species, Holarctic and Oriental; two undetermined species from Taiwan and India (BMNH, BPBM).

REFERENCE. Peck (1963: 375).

BIOLOGY. Parasites of larvae of Syrphidae (Diptera).

COMMENTS. Placed in the tribe Bothriothoracini, subtribe Bothriothoracina (Encyrtinae).

BRACHYPLATYCERUS De Santis

(Key couplet: 52)

Brachyplatycerus De Santis, 1972: 49. Type-species: *Brachyplatycerus minutum* De Santis, by original designation.

DISTRIBUTION AND SPECIES. One species, Neotropical; also one species reported from India (Hayat & Subba Rao, 1981).

BIOLOGY. Unknown.

COMMENTS. We have been unable to locate the material referred to by Hayat & Subba Rao (1981: 109) and presumably either the material was misidentified or has been lost.

The genus is related to *Pentelicus* (see comments under *Pentelicus*), differing in the number of funicle segments (see key).

CAENOHOMALOPODA Tachikawa

(Key couplet: 54)

Caenohomalopoda Tachikawa, 1979*a*: 169. Type-species: *Pseudhomalopoda shikokuensis* Tachikawa, by original designation.

DISTRIBUTION AND SPECIES. Four species, eastern Palaearctic, Oriental, Australasian; two from

review area: *guamensis* (Fullaway; Tachikawa, 1979a: 169) (Mariana Is., Hawaiian Is.) and *nagaii* (Tachikawa, 1978: 65) (Indonesia), also undetermined material from India, Taiwan, Indonesia, Brunei, Philippines and Australia (BMNH, BPBM).

REFERENCE. Key to species: Tachikawa *et al.* (1981).

BIOLOGY. Parasites of Diaspididae (Homoptera).

COMMENTS. In addition to the characters given by Tachikawa (1979a) to separate this genus from *Pseudhomalopoda* Girault we have found that the shape of the pronotum is important. In *Caenohomalopoda* the posterior margin of the pronotum is almost straight, whereas in *Pseudhomalopoda* it is strongly concave and medially incised.

The genus belongs in the tribe Habrolepidini, subtribe Habrolepidina (Encyrtinae) and can be separated from most other genera included here by the characters given in the key or by the key to genera of the subtribe provided by Tachikawa (1979a).

CALLIPTEROMA Motschulsky

(Key couplet: 229)

Callipteroma Motschulsky, 1863: 35. Type-species: *Callipteroma quinqueguttata* Motschulsky, by designation of Ashmead (1900b: 402).

Calocerinella Girault, 1913d: 46. Type-species: *Calocerinella trifasciata* Girault, by original designation.

Vosleria Timberlake, 1926: 1. Type-species: *Vosleria signata* Timberlake, by original designation. **Syn. n.**

DISTRIBUTION AND SPECIES. Five species, old World; three from review area: *australia* (Girault; Noyes, 1978: 543) (= *Vosleria signata* Timberlake, 1926: 3 **syn. n.**) (Australia), *sexguttata* Motschulsky; Noyes (1978: 546, 548) (Pakistan to Australia) and *testacea* Motschulsky; Noyes (1978: 549) (Pakistan to Australia).

REFERENCE. Revision: Noyes (1978).

BIOLOGY. Parasites of Pseudococcidae (Homoptera).

COMMENTS. The holotype of *Vosleria signata* has not been examined, but it is clear from Timberlake's detailed description that it is the same as *australia*.

We regard *sexguttata* and *quinqueguttata* as synonymous. This synonymy was first proposed by Bouček (1977a: 70) and has been confirmed by the examination of much fresh material collected in southern India and other parts of the region.

The genus is placed in the tribe Anagyrini, subtribe Leptomastideina (Tetracneminae) by Trjapitzin (1973a), although the Leptomastideina is here considered synonymous with the Anagyrina (see comments under *Leptomastidea*). The forewing venation suggests that *Callipteroma* may possibly be better placed in the Dinocarsini (or Dinocarsina if reduced to subtribal status within the Anagyrini).

CARABUNIA Waterston

(Key couplet: 224. Figs 128–131)

Carabunia Waterston, 1928a: 249. Type-species: *Carabunia myersi* Waterston, by original designation.

Elijahia Girault, 1928a: 1. Type-species: *Elijahia poeta* Girault, by monotypy. **Syn. n.**

Schillerana Girault, 1932a: 6. Type-species: *Schillerana dilatata* Girault, by monotypy. **Syn. n.**

DISTRIBUTION AND SPECIES. Seven species, Neotropical, Oriental and Australasian; four from review area: *dilatata* (Girault, 1932a: 6) (**comb. n.** from *Schillerana*) (Australia), *longimarginalis* Subba Rao (1973: 486) (India, Malaysia), *orientalis* Subba Rao (1971: 211) (India, Bangladesh, Thailand) and *poeta* (Girault, 1928a: 1) (**comb. n.** from *Elijahia*) (Australia), also unidentified material from India to Philippines, Papua New Guinea and Solomon Is. (BMNH, BPBM, CNC, GC).

REFERENCE. Part revision: Subba Rao (1973).

BIOLOGY. Parasites of nymphs of Cercopidae (Homoptera).

COMMENTS. The types of *dilatata* and *poeta* have been examined (QM) and are congeneric with the two above species described in *Carabunia* by Subba Rao. The Oriental and Australasian species of the genus (which could be called the *poeta*-group) differ from the Neotropical species in having a much more elongate postmarginal vein (that in *myersi* is very obscure, or perhaps absent, shortly distal to the apex of the stigmal vein); we do not consider this to be a generic difference.

The genus is placed in the tribe Neoclaudiini (Encyrtinae) by Trjapitzin (1973*b*) but we believe that this tribe is too narrowly defined (see comments under *Anagyrodes*). It can be separated from related genera by the combination of the mandible having one long sickle-shaped tooth, solid clava, long marginal and postmarginal veins of forewing, lightly to moderately infuscate forewing and the hypopygium more or less extending to apex of gaster.

CERAPTEROCEROIDES Ashmead

(Key couplet: 108. Figs 289, 290)

Cerapteroceroides Ashmead, 1904*b*: 156. Type-species: *Cerapteroceroides japonicus* Ashmead, by monotypy.

Metacerapterocerus Ishii, 1928: 151. Type-species: *Cerapterocerus fortunatus* Ishii, by original designation.

DISTRIBUTION AND SPECIES. Three species, Oriental and eastern Palaearctic; two species from review area: *japonicus* Ashmead; Tachikawa (1963: 148) (Pakistan) and *similis* (Ishii; Tachikawa, 1963: 150) (India); also undetermined material from Sri Lanka, India, Taiwan, Indonesia and Sarawak (BMNH, BPBM, UCR).

REFERENCE. Revision: Tachikawa (1963: 142–151).

BIOLOGY. Hyperparasitic on various Homoptera (Psyllidae, Aphididae, Coccidae, Pseudococcidae, Diaspididae) via other Encyrtidae and Aphelinidae (Hymenoptera).

COMMENTS. Placed in the tribe Cerapterocerini (Encyrtinae). It can be separated from other closely related genera by the characters provided in the key and by the key given by Annecke (1967: 100–101).

CERAPTEROCERUS Westwood

(Key couplets: 85, 108. Figs 41, 291, 292)

Cerapterocerus Westwood, 1833*b*: 495. Type-species: *Cerapterocerus mirabilis* Westwood, by monotypy.

Jurinia Costa, 1839: 115. Type-species: *Jurinia platicera* Costa, by designation of Bouček (1970: 86).

Telegraphus Ratzeburg, 1848: 152. Type-species: *Telegraphus maculipennis* Ratzeburg, by monotypy.

DISTRIBUTION AND SPECIES. Eight species, Holarctic, Afrotropical, Oriental, Australasian; four species from review area: *australia* Girault (1917*e*: 97) (Australia), *emersoni* Girault (1915*a*: 102) (Australia), *subapterus* Girault (1922*a*: 48) (Australia) and *virens* Agarwal (1963: 398) (India), also further undetermined material from India, China, Hong Kong, Singapore, Malaysia, Sarawak and Sulawesi (BMNH, BPBM, USNM).

BIOLOGY. Hyperparasites of Coccidae (Homoptera) via other Encyrtidae.

COMMENTS. The holotype of *australia* appears to be lost but it may be possible to recognise the species from Girault's description when freshly collected material becomes available. However, until that time the name should be considered a nomen dubium.

Placed in the tribe Cerapterocerini (Encyrtinae). It can be separated from other closely related genera by the characters given in the key and also by the key provided by Annecke (1967: 100–101).

CERAPTROCERELLA Girault

(Key couplets: 115, 128)

Ceraptrocerella Girault, 1918: 1. Type-species: *Ceraptrocerella apus* Girault, by original designation.
Austrotropidia Kerrich, 1978: 143. Type-species: *Tropidophryne flandersi* Compere, by original designation. **Syn. n.**

DISTRIBUTION AND SPECIES. Australia only; one species: *apus* Girault (1918: 1) (= *Tropidophryne flandersi* Compere; Kerrich, 1978: 143 **syn. n.**).

BIOLOGY. Parasites of Pseudococcidae (Homoptera).

COMMENTS. We have not seen the holotype of *flandersi* but a specimen determined as this by Kerrich (who has examined the holotype) is the same species as one compared with the syntypes of *apus*.

The genus belongs in the tribe Chrysoplatygerini, which also contains *Chrysoplatygerus*, *Hambletonia*, *Neoplatygerus* and *Tropidophryne*. It can be separated from these genera using the characters given in the key, or by using the key provided by Kerrich (1978: 113–114).

CERCHYSIELLA Girault

(Key couplets: 215, 324, 445, 447, 509. Fig. 127)

Aratus Howard, 1897: 155. Type-species: *Aratus scutellatus* Howard, by monotypy. [Homonym of *Aratus* Milne-Edwards, 1853.] **Syn. n.**

Cerchysiella Girault, 1914b: 60. Type-species: *Cerchysiella nigrella* Girault, by monotypy.

Zeteticontus Silvestri, 1915b: 343. Type-species: *Zeteticontus abilis* Silvestri, by original designation. **Syn. n.**

Mirrencyrtus Girault, 1915a: 115. Type-species: *Mirrencyrtus glabriscutellum* Girault, by original designation. **Syn. n.**

Ericydnella Girault, 1915a: 169. Type-species: *Ericydnella ashmeadi* Girault, by original designation. **Syn. n.**

Araticus Ghesquière, 1946: 368. [Replacement name for *Aratus* Howard.] **Syn. n.**

Prolitomastix Hoffer, 1954: 173. Type-species: *Prolitomastix vestonicensis* Hoffer, by original designation. **Syn. n.**

DISTRIBUTION AND SPECIES. Eighteen species, cosmopolitan; eight from review area: *abilis* (Silvestri, 1915b: 345) (**comb. n.** from *Zeteticontus*) (Pakistan), *glabriscutellum* (Girault, 1915a: 115) (**comb. n.** from *Mirrencyrtus*) (= *Mimencyrtus* [sic] *arboris* Girault, 1923a: 47 **syn. n.**) (Australia), *kamathi* (Mani & Saraswat in Mani et al., 1974: 84) (**comb. n.** from *Prionomitus*) (India), *nigra* Girault (1915a: 82) (Australia), *nigrella* Girault (1914b: 60) (= *Ericydnella ashmeadi* Girault, 1915a: 169 **syn. n.**) (Australia), *perkinsi* (Timberlake, 1924: 402) (**comb. n.** from *Zeteticontus*), *umbilicata* Girault (1915a: 83) (Australia) and *utilis* (Noyes, 1982: 457) (**comb. n.** from *Zeteticontus*) (Hawaiian Is.), also further undetermined material from throughout the region except New Zealand (BMNH, BPBM, CNC, AMNH, USNM, UCR, HC).

REFERENCE. Revision: Subba Rao (1972).

BIOLOGY. Parasites of larvae of Nitidulidae, Erotylidae and Silvanidae (Coleoptera) and apparently also Trypetidae (Diptera) (Tachikawa, 1981: 100).

COMMENTS. Girault (1915a: 82) published the formal description of the genus *Cerchysiella* stating that the type-species was *nigra* described on the same page. However, the generic name had been validated one year previously with the publication of the description of *Cerchysiella nigrella* Girault. The holotype of *Cerchysiella nigrella* has been examined (QM) and is congeneric with *Zeteticontus abilis* Silvestri, the type-species of *Zeteticontus*. Unfortunately therefore the name *Cerchysiella* has precedence over *Zeteticontus*. We do not feel that a submission to the International Commission on Zoological Nomenclature to ask for suppression of *Cerchysiella* in favour of *Zeteticontus* is necessary since the name *Zeteticontus* has been

relatively little used in the literature. In addition to the above, therefore, we propose that the following extra-limital species all be transferred to *Cerchysiella* (all **comb. n.**): *amurensis* Khlopunov (from *Zeteticontus*), *centennalis* Erdös (from *Zeteticontus*), *insularis* Howard (from *Bothriothorax*), *laevigata* De Santis (from *Aratiscus*), *laeviscutum* Thomson (from *Microterys*), *planiscutellum* Mercet (from *Zeteticontus*), *punctiscutellum* Subba Rao (from *Zeteticontus*), *scutellata* Howard (from *Aratus*), *takenakai* Tachikawa (from *Zeteticontus*) and *xanthopus* Masi (from *Zeteticontus*).

The genus is placed in the tribe Bothriothoracini, subtribe Coenocercina. It can be separated from related genera by the characteristic arrangement of the pegs constituting the filum spinosum (Fig. 127), and from related genera (*Pentacladocerus* and *Zaommoencyrtus*) by the characters given in the key.

CERCHYSIUS Westwood

(Key couplets: 288, 345. Fig. 176)

Cerchysius Westwood, 1832: 128. Type-species: *Encyrtus urocerus* Dalman, by designation of Westwood (1840: 73).

DISTRIBUTION AND SPECIES. Eleven species, cosmopolitan; five from review area: *australiensis* Ashmead (1900a: 342) (Australia), *australis* (Girault, 1914b: 59) (**comb. n.** from *Copidosoma*) (= *Cerchysius australis* Girault, 1915a: 85) (Australia), *hispidiscutum* Girault (1915a: 83) (Australia), *laticeps* Kerrich (1954: 372) (India, Malaysia) and *robustus* Girault (1915a: 84) (Australia), also further material, which may include several undescribed species, from India, Malaysia, Philippines and Australia (BMNH, BPBM, HC).

REFERENCE. Partial world revision: Kerrich (1954).

BIOLOGY. Parasites of Chamaemyiidae (Diptera).

COMMENTS. Girault (1917e: 96) synonymised *Copidosoma australis* with *Cerchysius australis*. It is clear from a comparison of the two descriptions that he inadvertently described the same specimen as a new species in two different genera in separate publications.

The genus is placed in the Microteryni, subtribe Pseudencyrtina (Encyrtinae) by Trjapitzin (1973b). However, it may be related to the subtribe Metaprionomitina of the Trechnitini since it can be very difficult to separate from some Australian species of *Psyllaephagus* which also have a long exerted ovipositor (see key).

CERCOBELUS Walker

(Key couplet: 49. Figs 17, 18, 293, 294)

Cercobelus Walker, 1842: vi. Type-species: *Encyrtus jugaeus* Walker, by monotypy.

DISTRIBUTION AND SPECIES. One described species, Europe; at least one undescribed species from Afrotropical region (BMNH) and from review area: India, Sarawak and Australia (BMNH, BPBM, QM, ANIC).

REFERENCE. Kryger (1951: 99–103).

BIOLOGY. Parasites of nymphs of Psyllidae (Homoptera).

COMMENTS. The genus is commonly attributed to Walker and dated 1840. However, Graham (1969) threw some doubt on the authorship of the genus, saying that the plate on which *Cercobelus jugaeus* was figured was actually drawn by Haliday. It is quite possible that Haliday drew the figures and that Walker wrote the legends to the plates. Whichever is the truth of the matter we shall probably never know and therefore we retain Walker as the author of the genus. Almost certainly the date commonly attributed is incorrect since the legends to the figures were published along with the index to volume 1 of the *Entomologist* and it is highly unlikely that the

index was published before the final part of this volume which was published in 1842. Therefore we have no hesitation in dating the genus 1842 and not 1840.

The genus is the sole representative of the tribe Cercobelini (Encyrtinae). Trjapitzin (1973*b*) states that the mandible is tridentate which is incorrect since a fourth tooth is present (Fig. 293). The structure of the gaster is very unusual in the Encyrtidae since it is highly telescopic (see Kryger, 1951: 101–102) and is probably adapted for its particular mode of oviposition.

CHARITOPUS Förster

(Key couplet: 263. Fig. 7)

Charitopus Förster, 1856: 31. Type-species: *Charitopus fulviventris* Förster, by designation of Förster (1860: 112).

Leptorhopala Motschulsky, 1863: 60. Type-species: *Leptorhopala cuprifrons* Motschulsky, by monotypy.

Eupelmomorpha Girault, 1915*a*: 43. Type-species: *Eupelmomorpha quadricolor* Girault, by designation of Gahan & Fagan (1923: 60). **Syn. n.**

Diversicornia Mercet, 1916*c*: 371. Type-species: *Diversicornia pinicola* Mercet, by original designation.

DISTRIBUTION AND SPECIES. Thirteen species, Palaearctic, Afrotropical, Oriental, Australasian; seven species from review area: *apicatus* (Mani & Saraswat in Mani *et al.*, 1974: 79) (India), *bicolor* (Girault, 1915*a*: 44) (**comb. n.** from *Eupelmomorpha*) (Australia), *fulviventris* Förster; Trjapitzin (1969*a*: 675) (India), *cuprifrons* (Motschulsky; Trjapitzin, 1964*b*: 242) (Sri Lanka), *panchgania* (Mani & Saraswat in Mani *et al.*, 1974: 81) (India), *quadricolor* (Girault, 1915*a*: 43) (**comb. n.** from *Eupelmomorpha*) (Australia) and *tricolor* (Girault, 1915*a*: 43) (**comb. n.** from *Eupelmomorpha*) (= *Eupelmomorpha hawthornei* Girault, 1915*a*: 44 **syn. n.**), also undetermined material from Sulawesi and Bangladesh (BMNH).

REFERENCES. Keys to species: Trjapitzin (1969*a*: 675) and Hoffer (1980: 388).

BIOLOGY. Unknown, but almost certainly parasites of Pseudococcidae (Homoptera).

COMMENTS. There appears to be some considerable variation in colour within some species and it is probable that many of the above species are synonymous since they are separated largely on colour differences, e.g. *bicolor*, *quadricolor* and *tricolor*.

The genus is placed in the tribe Charitopidini (Tetracneminae) which probably contains some of the most primitive encyrtids known. They are characterised by the very long marginal vein of the forewing, well-developed notaular lines and short last gastral tergite so that the cercal plates are situated near the apex of the gaster. Most genera have membranous areas surrounding the mid coxae which allow the mid legs to be flexed forwards, particularly when dead. This is also characteristic of the Tanaostigmatidae and some Eupelmidae.

CHEILONEURELLA Girault

(Key couplets: 259, 309, 408. Figs 149, 155, 295)

Cheiloneurella Girault, 1915*a*: 177. Type-species: *Cheiloneurella binotativentris* Girault, by original designation.

DISTRIBUTION AND SPECIES. Only one described species: *binotativentris* Girault (1915*a*: 177) (Australia), but also other material, containing at least one undescribed species, from India, Thailand, Hong Kong, Malaysia, Indonesia and Philippines (BMNH, BPBM).

BIOLOGY. Unknown.

COMMENTS. The genus very probably belongs in the tribe Cheiloneurini (Encyrtinae) and can be separated from other genera of the tribe by having a very long pronotum which is triangular in dorsal view (Fig. 149) and not covered by the head.

CHEILONEUROMYIA Girault

(Key couplet: 379)

Cheiloneuromyia Girault, 1915a: 178. Type-species: *Cheiloneuromyia simpliciscutellum* Girault, by original designation.

DISTRIBUTION AND SPECIES. Three species, Oriental and Australasian: *javensis* Girault (1916c: 480) (Indonesia, Hawaiian Is.), *planchoniae* (Howard in Howard & Ashmead, 1896: 637) (**comb. n.** from *Encyrtus*) (Sri Lanka) and *simpliciscutellum* Girault (1915a: 178) (Australia), also some undetermined material from India and Solomon Is. (BMNH, BPBM).

BIOLOGY. Parasites of Coccidae (Homoptera).

COMMENTS. The genus most probably belongs in the tribe Cheiloneurini (Encyrtinae).

CHEILONEURUS Westwood

(Key couplets: 87, 101, 103, 131, 351, 384, 474, 487. Figs 47, 50)

Cheiloneurus Westwood, 1833a: 343. Type-species: *Encyrtus elegans* Dalman, by monotypy.

Chrysopogagus Ashmead, 1894: 245. Type-species: *Chrysopogagus compressicornis* Ashmead, by monotypy.

Blatticida Ashmead, 1904c: 305. Type-species: *Blatticida pulchra* Ashmead, by original designation.

Saronotum Perkins, 1906: 259. Type-species: *Saronotum australiae* Perkins, by designation of Gahan & Fagan (1923: 130).

Cristatothorax Girault, 1911: 169. Type-species: *Cristatothorax pulcher* Girault, by original designation.

Eusemionella Girault, 1915a: 78. Type-species: *Eusemionella cristata* Girault, by original designation.

Syn. n.

Chrysopogagoides Girault, 1915a: 90. Type-species: *Chrysopogagoides westwoodi* Girault, by monotypy. **Syn. n.**

Paracheiloneurus Girault, 1915a: 119. Type-species: *Cheiloneurus perpulcher* Girault, by original designation (as subgenus of *Cheiloneurus*). **Syn. n.**

Epicheiloneurus Girault, 1915a: 173. Type-species: *Epicheiloneurus albicoxa* Girault, by original designation. **Syn. n.**

Eusemionopsis Girault, 1918: 3. Type-species: *Eusemionopsis centaurus* Girault, by original designation. **Syn. n.**

Metacheiloneurus Hoffer, 1957: 336. Type-species: *Metacheiloneurus moestus* Hoffer, by monotypy.

DISTRIBUTION AND SPECIES. Well over 100 species, cosmopolitan; 45 from review area: *albifuniculus* Hayat, Alam & Agarwal (1975: 48) (India), *axillaris* Hayat, Alam & Agarwal (1975: 55) (India), *australiae* (Perkins, 1906: 260) (Australia), *bangalorensis* (Subba Rao, 1957: 382) (India), *basiri* Hayat, Alam & Agarwal (1975: 53) (India), *beerwahi* (Girault, 1925b: 100) (**comb. n.** from *Epicheiloneurus*) (Australia), *burnsi* (Girault, 1926b: 69) (**comb. n.** from *Eusemionella*) (Australia), *cheles* (Walker, 1839: 37) (**comb. n.** from *Encyrtus*) (Australia), *chlorodryini* Perkins (1906: 261) (= *Cheiloneurus dubius* Girault, 1915a: 88 **syn. n.**) (Australia), *chrysopae* Fullaway (1946: 207) (Mariana Is.), *cinctiventris* (Girault, 1929b: 311) (**comb. n.** from *Epicheiloneurus*) (Australia), *cristatus* (Girault, 1915a: 78) (**comb. n.** from *Eusemionella*) (Australia), *cupreicollis* (Ashmead; Noyes, 1979: 50) (Australia), *diversicolor* Hayat, Alam & Agarwal (1975: 134) (India), *dumasi* Girault (1932a: 2) (Australia), *flaccus* (Walker, = *americanus* Perkins, 1906: 260) (Hawaiian Is.), *gonatopodis* Perkins (1906: 261) (Australia), *hemipterus* (Girault, 1920a: 48) (**comb. n.** from *Eusemionella*) (Australia), *hugoi* (Girault, 1915a: 156) (**comb. n.** from *Cristatothorax*) (= *Cristatothorax nobilis* Girault, 1922b: 100 **syn. n.**) (Australia), *javanus* Perkins (1912: 17) (Java, Brúnei), *javensis* Girault (1917a: 3) (Java), *kerrichi* Hayat, Alam & Agarwal (1975: 127) (India), *latifrons* Hayat, Alam & Agarwal (1975: 108) (India), *laticapus* (Girault, 1916c: 481) (**comb. n.** from *Cristatothorax*) (Malaysia, Java), *longicornis* Hayat, Alam & Agarwal (1975: 120) (India), *malayensis* Noyes & Chua (1977: 544) (Malaysia), *margiscutellum* (Girault, 1917g: 141) (**comb. n.** from *Bavanusia* [sic]) (Australia), *mazzinini* (Girault, 1915a: 103) (**comb. n.** from *Chrysopogagus*) (Australia), *nepalensis* Khan

& Agarwal (1978: 23) (Nepal), *nigricornis* Hayat, Alam & Agarwal (1975: 122) (India), *novimandibularis* (Girault, 1915a: 158) (**comb. n.** from *Cristatothorax*) (= *Cristatothorax mandibularis* Girault, 1915a: 157 **syn. n.**, = *Cristatothorax mackayensis* Girault, 1915a: 158 **syn. n.**, = *Cristatothorax sublimis* Girault, 1929b: 314 **syn. n.**, = *Cristatothorax partipes* Girault, 1932a: 3 **syn. n.**) (Australia), *noxius* Compere (1925: 302) (Hawaiian Is.), *pasteuri* (Girault, 1915a: 159) (**comb. n.** from *Cristatothorax*) (= *Cristatothorax bidentimaxillae* Girault, 1915a: 157 **syn. n.**, = *Cristatothorax vinculum* Girault, 1915a: 159 **syn. n.**, = *Epicheiloneurus albicoxa* Girault, 1915a: 177 **syn. n.**, = *Cristatothorax bidentimaxillae poeta* Girault, 1932a: 3 **syn. n.**) (Australia), *perpulcher* Girault (1915a: 88) (Australia), *purpureicinctus* (Girault, 1915a: 104) (**comb. n.** from *Chrysopophagus*) (= *Eusemionopsis centaurus* Girault, 1918: 3 **syn. n.**, = *Chrysopophagus variocelli* Girault, 1924a: 2 **syn. n.**) (Australia), *purpureiventris* Girault (1915a: 87) (Australia), *pyrillae* Mani (1939: 73) (India), *quadricolor* (Girault 1915a: 157) (Pakistan, India, Australia), *rara* (Girault, 1922a: 42) (**comb. n.** from *Eusemionella*) (Australia), *regis* (Girault, 1932a: 3) (**comb. n.** from *Cristatothorax*) (Australia), *saissetiae* Noyes & Chua (1977: 541) (Malaysia), *seminigrilavus* Girault (1915a: 88) (Australia), *unicolor* Mercet (1922a: 155) (Java), *viridiscutum* (Girault, 1915a: 158) (**comb. n.** from *Cristatothorax*) (Australia), *westwoodi* (Girault, 1915a: 90) (**comb. n.** from *Chrysopophagoides*) (Australia) and *yasumatsui* Trjapitzin (1971b: 123) (India), also probably many other species amongst material from throughout the region (BMNH, BPBM, DSIR, QM, ANIC, CNC, UCR, HC).

REFERENCES. Key to Palaearctic species: Trjapitzin (1971b: 123–125), key to Indian species: Hayat *et al.* (1975: 45–47), Khan & Agarwal (1978: 21).

BIOLOGY. Parasites of Dryinidae and chalcids (Hymenoptera), mainly Aphelinidae and Encyrtidae, parasitic on other insects, notably Homoptera (Auchenorrhyncha, also Coccidae, Pseudococcidae, etc.) and also predatory Diptera, e.g. Drosophilidae.

COMMENTS. The single extant female syntype of *Encyrtus cheles* Walker (BMNH) is here designated LECTOTYPE. It belongs to the same species-group as *novimandibularis*, but is in poor condition, lacking both forewings and most of the antennae.

We have not examined the holotype of *Cheiloneurus rufescens* Motschulsky (1863: 53), but according to Z. Bouček (pers. comm.) it belongs to the family Eulophidae.

The genus is placed in the tribe Cheiloneurini (Encyrtinae). It appears to be a very large and diverse genus whose limits are uncertain. Generally speaking, it is characterised by the arrangement of the setae in the basal cell of the forewing, by the wing venation (relatively long marginal and short stigmal and postmarginal veins), normally infusate forewing, the usual presence of an apical tuft of setae on the scutellum, and the hypopygium never reaching the apex of the gaster. We have included here in *Cheiloneurus* two unusual species, one being *cinctiventris* which has the unusual character of the basal cell of the forewing being almost entirely setose and the other, an undescribed species from Papua New Guinea (BPBM), which has the forewing entirely hyaline and an unusually long marginal vein (Fig. 50). It is possible that once this difficult complex of genera (which includes *Tobiasia* Trjapitzin, *Neabrolepoideus*, *Baeoanusia*, *Neblatticida* and *Mesocalocerinus*) is studied in more detail a number of them will be considered synonymous with *Cheiloneurus*.

CHRYSOPLATYCERUS Ashmead

(Key couplet: 116. Figs 54, 55)

Rileyia Howard in Smith, 1888: 80. Type-species: *Rileyia splendens* Howard, by monotypy. [Homonym of *Rileyia* Ashmead, 1888.]

Chrysoplatycerus Ashmead, 1889: 38. [Replacement name for *Rileyia* Howard.]

Encyrtolophus De Santis, 1972: 49. Type-species: *Encyrtolophus flavicollis* De Santis, by original designation.

Paraplatycerus Hall, 1974: 19. Type-species: *Paraplatycerus citriculus* Hall, by original designation.

Metaplatycerus Gordh & Trjapitzin in Trjapitzin & Gordh, 1978a: 384. Type-species: *Chrysoplatycerus ferrisi* Timberlake, by original designation.

DISTRIBUTION AND SPECIES. Four species, New World, Afrotropical; one species in review area: *splendens* (Howard; Kerrich, 1978: 140) (Hawaiian Is.).

REFERENCE. Revision: Kerrich (1978: 136–142).

BIOLOGY. Parasites of Pseudococcidae (Homoptera).

COMMENTS. Placed in the tribe Chrysoplatygerini, subtribe Chrysoplatygerina (Tetracneminae).

CLADISCODES Subba Rao

(Key couplet: 480. Fig. 235)

Cladiscodes Subba Rao, 1977: 18. Type-species: *Cladiscodes sacchari* Subba Rao, by original designation.

DISTRIBUTION AND SPECIES. One species: *sacchari* Subba Rao (1977: 19) (India), also undetermined material from Laos, Vietnam and Australia (BMNH, BPBM).

BIOLOGY. Parasites of Pseudococcidae (Homoptera).

COMMENTS. The genus is related to *Monodiscodes* and *Metaphaenodiscus* (tribe Aenasiini, see comments under *Aenasius*) and is characterised by the costal cell of the forewing being abruptly incised at its apex and by the distinct venation and shape of the wing (Fig. 235).

CLAUSENIA Ishii

(Key couplet: 265)

Clausenia Ishii, 1923: 98. Type-species: *Clausenia purpurea* Ishii, by original designation.

DISTRIBUTION AND SPECIES. Eleven species, Afrotropical, Palaearctic, Oriental and Pacific; two from review area: *lacca* (Agarwal, 1962: 278) (India) and *purpurea* Ishii (Kerrich, 1967: 182) (S. China, Taiwan, Hawaiian Is.).

REFERENCE. Revision: Kerrich (1967: 181–188).

BIOLOGY. Parasites of Pseudococcidae (Homoptera).

COMMENTS. Placed in the tribe Ericydnini by Trjapitzin (1973) but probably would be better placed in the Charitopidini.

COAGERUS gen. n.

(Key couplet: 487. Figs 245, 296–299)

Type-species: *Coagerus bouceki* sp. n. Gender: feminine.

♀. *Head*. In facial view about as long as broad and in profile clearly less than twice as long as broad and anteriorly more or less gradually and evenly curved, but most strongly at top of antennal scrobes. Eye with posterior margin very slightly concave, almost straight, about one-third longer than broad, almost naked with some sparse short setae each not longer than half the diameter of a facet, eye just reaching occipital margin which is sharp. Malar space a little more than half length of eye and with sulcus absent. Frontovertex about one-fifth head width, ocelli forming an angle of about 45°, posterior ocellus a little less than half its own major diameter from occipital margin and touching eye margin. Antennal scrobes shallow, meeting dorsally and not quite reaching half way between toruli and anterior ocellus; antennal torulus separated from mouth margin by about half its length and from other torulus by about two to three times its own length, its upper margin at least about its own length below lowest eye margin, clypeal margin very shallowly produced below toruli. Antennal scape about twice as long as minimum width of frontovertex and slightly flattened and broadened, slightly more than three times as long as broad, pedicel slightly less than half as long as scape, cylindrical and clearly longer than any of the funicle segments the first four of which are distinctly transverse and the fifth and sixth subquadrate; clava three-segmented with an oblique apical truncation, the outer suture strongly converging with the inner, the truncated surface with two rows of 'tubular' setae and also a few scattered on other surfaces of apical segment of clava, these only visible on slide material examined at higher magnifications ($\times 250+$); longitudinal sensillae on fifth

and sixth funicle segment and clava only. Frontoververtex with shallow, regular, hexagonal, raised, reticulate sculpture, this becoming irregular and more longitudinally elongate on lower parts of face; setae very sparse, inconspicuous, brown and short, not present on frontoververtex below anterior ocellus except along eye margin. Mandible with three equal acute apical teeth; maxillary and labial palpi not visible in slide-mounted material available.

Thorax. In side view with mesoscutum and scutellum distinctly convex and with metapleurum and propodeum together quite broadly in contact with hind coxa. In dorsal view with posterior margin of pronotum moderately concave; visible part of mesoscutum about twice as broad as long, its posterior margin slightly convex medially; axillae touching; scutellum a little broader than long, its apex rounded; propodeum medially not more than about one-tenth length of scutellum. Mesoscutum with very shallow, raised, squamiform-reticulate sculpture, that on axillae similar but a little deeper; scutellum with deep, fine, raised, longitudinally striate-reticulate sculpture (Fig. 297) clearly a lot deeper than sculpture of mesoscutum, apical one-fifth and extreme sides smooth and polished; dorsum of thorax with fairly numerous, moderately long, brown setae. Forewing more or less hyaline, but with a short fuscous streak in disc beyond venation and slight clouding below marginal vein, wing nearly three times as long as broad; lineal calva not interrupted and open; film spinosum present; submarginal vein with parastigma not conspicuously thickened, with an apical hyaline break; costal cell about 13 times as long as broad with only two or three setae dorsally near apex; marginal vein about four or five times as long as broad, about twice as long as stigmal which is clearly longer than postmarginal, stigmal vein with three apical sensillae arranged in a line. Hindwing hyaline, about two-thirds as long as forewing, about four to five times as long as broad, marginal fringe about one-third wing width. Mid tibial spur about as long as or a little shorter than basal mid tarsal segment.

Gaster. Slightly longer than thorax with ovipositor slightly exerted, cercal plates in basal half, hypopygium reaching to about half way along gaster, last tergite slightly shorter than mid tibia; ovipositor about one-third longer than mid tibia, gonostyli free and about one-third to two-fifths as long as ovipositor.

♂. Unknown.

COMMENTS. At first glance this new genus bears a striking superficial resemblance to *Paraleurocerus* Girault but is easily separated by the three-segmented clava (in *Paraleurocerus* it is entire), postmarginal vein of forewing shorter than stigmal (in *Paraleurocerus* it is clearly longer) and infuscate forewings. However, the basic type of wing venation, strongly tridentate mandible and structure of ovipositor suggest that it has some affinity with the group of genera to which *Paraleurocerus* belongs, i.e. tribe Copidosomatini, subtribe Ageniaspidiina, but can be separated from all other genera included in this subtribe by the postmarginal vein of the forewing being shorter than the stigmal.

The type-species of the genus is named in honour of Dr Z. Bouček.

Coagerus bouceki sp. n.

(Figs 245, 296–299)

♀. Length (excluding ovipositor): 0.67–0.97 mm (holotype, 0.97 mm).

Colour. Head black dorsally with dull greenish and brassy reflections, around mouth and antennal toruli slightly purplish; antennal torulus, basal half or so of scape and pedicel dark brown, remainder of antenna yellow, the apex of clava indistinctly fuscous; pronotum purplish brown, mesoscutum shining metallic green, along anterior and posterior margins a little purplish; tegula brown; scutellum matt, black, apical one-fifth or so and extreme sides polished and metallic green; mesopleurum purplish brown, slightly shiny with some brassy, green and bluish reflections; propodeum dark purple-brown laterally on outer face with distinct bluish hue; legs white to yellow with apical one-third of mid femur, extreme base and a narrow sub-basal band on mid tibia and extreme apex of hind femur dark brown; forewing as in Fig. 245; gaster with venter and basal area dorsally yellow; apex dorsally continuing along sides to base dark purplish brown; exerted part of gonostyli dark brown, apices yellowish.

Head. Relative measurements (holotype): head length 51, head width (facial view) 51, head width (side view) 29, minimum frontoververtex width 10.5, malar space 22, eye length 35, eye width 28, POL 6, OOL 0.25, scape length 23, scape width 6, other proportions of antenna Fig. 298. Smaller specimens tend to have the eyes a little smaller and thus the frontoververtex correspondingly wider.

Thorax. Sculpture of scutellum Fig. 297. Relative measurements (holotype): forewing length 128,

forewing width 45, other proportions of forewing as in Figs 245, 296; hindwing length 90, hindwing width 19.

Gaster. Relative lengths (paratype): last tergite 53, ovipositor 85, gonostyli 26, [mid tibia 62]; genitalia Fig. 299.

♂. Unknown.

BIOLOGY. Unknown.

DISTRIBUTION. India.

MATERIAL EXAMINED

Holotype ♀, **India**: Tamil Nadu, Coimbatore, 25.ix.-1.x.1979 (J. S. Noyes) (BMNH).

Paratypes. **India**: 5 ♀, same data as holotype; 1 ♀, Karnataka, Bangalore, 3.xi.1979 (Z. Bouček) (BMNH).

COCCIDAPHYCUS Blanchard

(Key couplet: 72. Fig. 32)

Coccidaphycus Blanchard, 1940: 110. Type-species: *Coccidaphycus nigricans* Blanchard, by original designation.

DISTRIBUTION AND SPECIES. One described species, Neotropical; one undescribed species from Sarawak (BMNH).

BIOLOGY. Parasites of Coccidae (Homoptera).

COMMENTS. The genus is closely related to *Trechnites* (tribe Trechnitini, subtribe Trechnitina), differing in biology (*Trechnites* spp. are parasites of nymphs of Psyllidae) and in the characters given in the key.

COCCIDENCYRTUS Ashmead

(Key couplets: 194, 329, 519. Figs 117, 189)

Coccidencyrtus Ashmead, 1900b: 383. Type-species: *Encyrtus ensifer* Howard, by original designation.

Encyrtomyia Girault, 1915a: 131. Type-species: *Encyrtomyia albiflagellum* Girault, by original designation. **Syn. n.**

Omphalencyrtus Girault, 1915a: 169. Type-species: *Omphalencyrtus wallacei* Girault, by original designation. **Syn. n.**

Coccidocyrtoides Blanchard, 1940: 107. Type-species: *Coccidocyrtoides annulipes* Blanchard, by designation of De Santis (1967: 161).

Neoadelencyrtus Hayat, Alam & Agarwal, 1975: 72. Type-species: *Neoadelencyrtus mandibularis* Hayat, Alam & Agarwal, by original designation. **Syn. n.**

DISTRIBUTION AND SPECIES. Thirty-three species, cosmopolitan; nine species from review area: *albiflagellum* (Girault, 1915a: 131) (**comb. n.** from *Encyrtomyia*) (Australia), *albitarsis* (Girault, 1915a: 132) (**comb. n.** from *Encyrtomyia*) (Australia), *auricornis* (Girault, 1924a: 2) (**comb. n.** from *Epitetracnemus*) (Australia), *australis* (Girault, 1915a: 132) (**comb. n.** from *Encyrtomyia*), (Australia) *bicolor* (Girault, 1915a: 141) (**comb. n.** from *Coccidoxenus*) (Australia), *mandibularis* (Hayat, Alam & Agarwal, 1975: 74) (**comb. n.** from *Neoadelencyrtus*) (India), *ochraceipes* Gahan (1927a: 18) (Hawaiian Is.), *secundus* (Girault, 1915a: 131) (**comb. n.** from *Encyrtomyia*) (Australia) and *wallacei* (Girault, 1915a: 169) (**comb. n.** from *Omphalencyrtus*) (Australia).

BIOLOGY. Parasites of Diaspididae (Homoptera).

COMMENTS. The type-species of *Neoadelencyrtus* differs from the other species of *Coccidencyrtus* only in the number of segments in the maxillary and labial palpi: *mandibularis* has four-segmented maxillary and three-segmented labial palpi whilst all species of *Coccidencyrtus* that have been examined have one segment fewer in each. We do not think that this difference warrants separate generic status.

Encyrtomyia and *Omphalencyrtus* are rather more problematic. The type-species of *Omphalencyrtus* has the funicle distinctly four-segmented, whilst that of *Encyrtomyia* has the first segment with two partial sutures so that in slide-mounted material it could be taken as one-segmented (i.e. four-segmented funicle) and in dry-mounted material it appears three-segmented (i.e. six-segmented funicle). Examination of the extant types of *albitarsis* and *secundus* (which may be synonymous with *albiflagellum*) also shows this to be the case, whilst in *australis* the funicle is definitely four-segmented. Several other specimens with partial segmentation of the first funicle segment have also been examined. The occurrence of an apparent partial fusion of the first three funicle segments in some specimens, or species, is therefore not uncommon. Taking this into consideration and the fact that the first funicle segment of both *australis* and *wallacei* is longer than those following and is about as long as that which might be expected if the first three segments became fused, we have no hesitation in regarding *Omphalencyrtus* and *Encyrtomyia* as synonymous with *Coccidoencyrtus*.

The genus is placed in the tribe Habrolepidini (Encyrtinae) by Trjapitzin & Gordh (1978b).

COCCIDOCTONUS Crawford

(Key couplets: 199, 300, 367. Fig. 125)

Coccidoctonus Crawford, 1912: 167. Type-species: *Coccidoctonus trinidadensis* Crawford, by original designation.

Quaylea Timberlake, 1919b: 214. Type-species: *Cerchysius whittieri* Girault, by original designation.

Cerchysiopsis Girault, 1922b: 108. Type-species: *Cerchysiopsis lowelli* Girault, by monotypy. **Syn. n.**

DISTRIBUTION AND SPECIES. Seven described species, New World, Australasia, Pacific; six species from review area: *dubius* (Girault, 1915a: 102) (**comb. n.** from *Rhopalencyrtoidea*) (= *Rhopalencyrtoidea cinctifemur* Girault, 1925a: 2 **syn. n.**, = *Paraenasomyia lizti* Girault, 1932b: 1 **syn. n.**) (Australia), *lowelli* (Girault, 1922b: 108) (**comb. n.** from *Cerchysiopsis*) (Australia), *oviductus* (Girault, 1915a: 85) (**comb. n.** from *Cerchysius*) (Australia), *psyllae* (Riek, 1962b: 189) (**comb. n.** from *Echthroplexis*) (Australia), *terebratus* (Hayat, Alam & Agarwal, 1975: 69) (**comb. n.** from *Echthroplexis*) (India) and *whittieri* (Girault; = *aliena* Timberlake, 1919b: 216) (Hawaiian Is., New Zealand), also several other species from Australia (BMNH, QM, ANIC).

BIOLOGY. Hyperparasites of Coccidae, Pseudococcidae and Psyllidae (Homoptera) via Pteromalidae and other Encyrtidae (Hymenoptera).

COMMENTS. Girault (1932b) incorrectly proposed *lizti* as a replacement name for *Rhopalencyrtoidea dubia* Girault, 1915, believing that it was preoccupied by *Paraenasomyia dubia* Girault, 1923 when he presumably transferred this species to *Paraenasomyia*. This is obviously incorrect and thus we revert to the original name. *Paraenasomyia dubia* Girault, 1923 is placed here in *Psyllaephagus*. It is possible that *Nezarhopalus caudatus* also belongs in *Coccidoctonus*.

This genus is closely related to *Syrphophagus* (tribe Microteriyini, subtribe Syrphophagina). The subtribe to which these genera belong is a very difficult, complex group whose genera are very difficult to define. We have separated them in the key by the use of the following simple characters in order to retain most of the generic names as valid until a more detailed study of the group can be undertaken. Two of the genera in this group have the hypopygium extending past the apex of the last tergite, i.e. *Coccidoctonus* and *Epiblatticida*, whilst in the others it does not extend past the apex of the last tergite. These two genera can be separated from each other by the characters given in the key. Two of the remaining genera have the hypopygium more or less reaching the apex of the gaster, one has the postmarginal vein of the forewing longer than the stigmal (*Rhopalencyrtoidea*), whilst in the other it is not longer than the stigmal (*Teleterebratus*). The remaining genera, *Bachiana* and *Syrphophagus*, have the hypopygium not reaching further than four-fifths along the gaster. *Bachiana* has the clava two-segmented (or possibly entire) whilst that of *Syrphophagus* is always three-segmented.

COCCIDOXENOIDES Girault

(Key couplet: 503. Fig. 242)

Coccidoxenoides Girault, 1915a: 173. Type-species: *Coccidoxenoides perminutus* Girault, by original designation.

Pauridia Timberlake, 1919b: 206. Type-species: *Pauridia peregrina* Timberlake, by original designation.
Syn. n.

DISTRIBUTION AND SPECIES. Two species, New World, Afrotropical, Oriental, Australasian and Pacific; both found in review area and possibly synonymous: *peregrinus* (Timberlake, 1919b: 208) (**comb. n.** from *Pauridia*) (Pakistan, India, Java, Philippines, Hawaiian Is.) and *perminutus* Girault (1915a: 173) (= *Fulgoridicida babindae* Girault, 1922a: 47 **syn. n.**) (Australia), also material from the Cook Is. and New Caledonia (BMNH, BPBM, DSIR).

BIOLOGY. Parasites of Pseudococcidae (Homoptera).

COMMENTS. The holotype of *Coccidoxenoides perminutus* has been examined (QM). It is congeneric with and possibly conspecific with *Pauridia peregrina*. Although *Pauridia* is a fairly well-known name we prefer to follow the rules of zoological nomenclature and use the older name, *Coccidoxenoides*, for the genus. We therefore do not think that it is necessary to apply to the International Commission for Zoological Nomenclature to ask for suppression of *Coccidoxenoides* in favour of *Pauridia*.

The genus is placed in the Pauridiini (Tetracneminae).

COELASPIDIA Timberlake

(Key couplet: 75)

Coelaspida Timberlake, 1923: 326. Type-species: *Coelaspida osborni* Timberlake, by original designation.

DISTRIBUTION AND SPECIES. One described species, Neotropics and Hawaiian Is.: *osborni* Timberlake (1923: 330).

BIOLOGY. Parasites of Pseudococcidae (Homoptera).

COMMENTS. Placed in the tribe Acroaspidiini (Tetracneminae).

COELOPENCYRTUS Timberlake

(Key couplets: 176, 218, 497, 508. Figs 100, 118, 119, 247, 248, 300, 301)

Coelopencyrtus Timberlake, 1919b: 218. Type-species: *Coelopencyrtus odyneri* Timberlake, by original designation.

Nesencyrtus Timberlake, 1919b: 223. Type-species: *Adelencyrtus kaalae* Ashmead, by original designation.

Epaenasomyia Girault, 1919b: 53. Type-species: *Epaenasomyia pallidiceps* Girault, by original designation. [Homonym of *Epaenasomyia* Girault, 1917.] **Syn. n.**

Giraultella Gahan & Fagan, 1923: 66. [Replacement name for *Epaenasomyia* Girault, 1919.] **Syn. n.**

Batrachencyrtus Jansson, 1957: 71. Type-species: *Batrachencyrtus calidii* Jansson, by monotypy.

Lymanera Szelenyi, 1972a: 125. Type-species: *Lymanera crassicornis* Szelenyi, by original designation.
Syn. n.

DISTRIBUTION AND SPECIES. Twenty-five species, cosmopolitan; 10 species from review area: *asperithorax* (Rayment, 1949: 253) (**comb. n.** from *Aphycus*) (Australia), *kaalae* (Ashmead; Timberlake, 1922a: 139) (Hawaiian Is.), *krishnamurtii* (Mahdihassan, 1957: 182) (**comb. n.** from *Giraultella*) (India), *mauiensis* Timberlake (1922a: 137) (Hawaiian Is.), *odyneri* Timberlake (1919b: 221) (Hawaiian Is.), *orbi* Timberlake (1920: 422) (Hawaiian Is.), *pallidiceps* (Girault, 1919b: 53) (**comb. n.** from *Epaenasomyia*) (Java), *sexramosus* (Timberlake, 1922a: 141) (Hawaiian Is.), *swzeyi* Timberlake (1919b: 222) (Hawaiian Is.) and *xylocopae* (Girault,

1919b: 54) (**comb. n.** from *Epaenasomyia*) (Java), also further undetermined material from India to Papua New Guinea (BMNH, BPBM, RMNH).

REFERENCE. Review of Hawaiian species: Timberlake (1922a: 135–142).

BIOLOGY. Polyembryonic parasites of larvae of Xylocopidae, Apidae and Hylaeidae (Hymenoptera).

COMMENTS. The syntypes of *Epaenasomyia pallidiceps* in the Queensland Museum have been examined. They are morphologically very close to species of *Coelopencyrtus* (although differing in colour) and therefore we propose that the two genera be considered synonymous.

The holotype of *Lymanera crassicornis* has been examined (HNHM) and is a typical species of *Coelopencyrtus*.

There are several specimens determined as *Giraultella krishnamurthi* in the collections of the USNM. They are almost certainly syntypes and belong to the genus *Coelopencyrtus*.

Zarhopaloides cinctithorax (Girault, 1939a: 20) and *Anagyrus saintpierrei* Girault (1913c: 112) may both be aberrant species belonging in this genus.

The genus is placed in the tribe Copidosomatini, subtribe Coelopencyrtina (Encyrtinae) by Trjapitzin (1973b).

COMPERIA Gomes

(Key couplet: 132)

Comperia Gomes, 1942: 41. Type-species: *Dicarnosis merceti* Compere, by original designation.

DISTRIBUTION AND SPECIES. Seven species, New World, Afrotropical; one species found in review area: *merceti* (Compere, 1938: 317) (India, Hawaiian Is.), also some undetermined material of at least one further species from Samoa and Australia (BMNH, BPBM).

BIOLOGY. Parasites of cockroach oothecae (Orthoptera, Blattodea).

COMMENTS. Placed in the tribe Comperiini by Trjapitzin (1973b), but possibly should be considered as a subtribe of the Microteriyini.

COMPERIELLA Howard

(Key couplet: 105. Figs 302, 303)

Comperiella Howard, 1906: 121. Type-species: *Comperiella bifasciata* Howard, by monotypy.

Pseudanusia Girault, 1915a: 155. Type-species: *Pseudanusia pia* Girault, by original designation.

Habrolepistia Mercet, 1921: 668. Type-species: *Habrolepistia cerapterocera* Mercet, by original designation.

DISTRIBUTION AND SPECIES. Eight species, cosmopolitan; six from review area: *aspidiotiphaga* Subba Rao (1966: 137) (Pakistan, India), *bifasciata* Howard (= *cerapterocera* Mercet, 1921: 669) (Pakistan, China, Hawaiian Is.), *indica* Ayyar (1934: 219) (India), *lemniscata* Compere & Annecke (1961: 32) (Pakistan, India, Hong Kong), *pia* (Girault; Sands & Snowball, 1980: 41) (Australia) and *unifasciata* Ishii; Compere (1926: 49) (India).

REFERENCE. Review of species: Hayat (1977: 249).

BIOLOGY. Parasites of Diaspididae (Homoptera).

COMMENTS. Placed in the tribe Habrolepidini, subtribe Comperiellina (Encyrtinae).

CONCHYNILLA Girault

(Key couplet: 252)

Conchynilla Girault, 1923c: 148. Type-species: *Conchynilla fuscipennis* Girault, by monotypy.

DISTRIBUTION AND SPECIES. One species, Australia only: *fuscipennis* Girault (1923c: 148).

BIOLOGY. Unknown.

COMMENTS. Girault states in his unpublished manuscript (QM), under *Cerchysiella fuscipennis*, that the spelling of the generic name *Conchynilla* is incorrect and that it should have been published as *Cerchysiella*. Thus when stating 'As genotype but . . .', he must have actually been referring to *Cerchysiella nigra* (which he had designated as type-species of the genus). However, Article 32a(ii) of the *International Code of Zoological Nomenclature* states that if there is no clear evidence of mis-spelling in the original publication then the spelling must stand. In this case there is clear evidence of an error by Girault, but not that the spelling of the generic name is incorrect. Therefore, since the generic name *Conchynilla* is not unavailable for reasons of homonymy and the species epithet is valid (under Article 11g(g) of the *Code*) and *fuscipennis* does not belong to any other genus known to us, we here regard the genus and generic name as valid.

The genus is probably related to the subtribe Syrphophagina (Microteriyini), but can be distinguished from all other included genera by the distinctly infusate forewings and very long, sharply tridentate mandible.

COPIDOSOMA Ratzeburg

(Key couplets: 235, 250, 287, 292, 297, 325, 394, 432, 453, 484, 498, 507, 529. Figs 140, 142, 183, 204, 241, 249)

- Copidosoma* Ratzeburg, 1844: 157. Type-species: *Copidosoma boucheanum* Ratzeburg, by monotypy.
Litomastix Thomson, 1876: 171. Type-species: *Encyrtus chalconotus* Dalman, by designation of Ashmead (1900: 363).
Pentacnemus Howard, 1892: 366. Type-species: *Pentacnemus bucculatricis* Howard, by monotypy. **Syn. n.**
Parapsilophrys Howard, 1898b: 232. Type-species: *Parapsilophrys gelechia* Howard, by monotypy.
Berecyntus Howard, 1898b: 237. Type-species: *Berecyntus bakeri* Howard, by monotypy.
Pseudencyrtella Girault, 1913e: 113. Type-species: *Pseudencyrtella fasciata* Girault, by original designation. **Syn. n.**
Zaomencyrtus Girault, 1915a: 107. Type-species: *Zaomencyrtus lepidopterophagus* Girault, by original designation. **Syn. n.**
Paracaenocercus Girault, 1915a: 116. Type-species: *Paracaenocercus perseverans* Girault, by monotypy. **Syn. n.**
Paracopidosomopsis Girault, 1916a: 49. Type-species: *Berecyntus floridanus* Ashmead, by original designation.
Verdunia Mercet, 1917b: 203. Type-species: *Verdunia gloriosa* Mercet, by original designation.
Litomastiellus Mercet, 1921: 443. Type-species: *Litomastix claviger* Mercet by designation of Peck in Muesebeck *et al.* (1951: 481).
Limastotix Mercet, 1921: 443. Type-species: *Litomastix hispanicus* Mercet, by monotypy.
Angeliconana Girault, 1922e: 150. Type-species: *Angeliconana eja* Girault, by monotypy. **Syn. n.**
Parasteropaesus Girault, 1923a: 50. Type-species: *Parasteropaesus lotae* Girault, by monotypy. **Syn. n.**
Neocopidosoma Ishii, 1923: 101. Type-species: *Neocopidosoma komabae* Ishii, by monotypy.
Mesocopidosomyia Girault, 1925b: 93. Type-species: *Mesocopidosomyia variventris* Girault, by monotypy. **Syn. n.**
Mesencyrtus Timberlake, 1941: 228. Type-species: *Mesencyrtus insularis* Timberlake, by original designation. **Syn. n.**
Berecyntiscus Ghesquière, 1946: 368. [Unnecessary replacement name for *Berecyntus* Howard.]
Arrenoclavus Doutt, 1948: 145. Type-species: *Copidosoma koehleri* Blanchard, by original designation.

DISTRIBUTION AND SPECIES. About 150 species, cosmopolitan; 25 species from review area: *aeripes* (Girault, 1932b: 1) (**comb. n.** from *Zaomencyrtus*) (Australia), *australia* Girault (1917g: 133) (Australia), *australicum* Girault (1917g: 133) (Australia), *australis* Girault (1917g: 133) (Australia), *compressiventris* Girault (1915a: 112) (Australia), *daccaensis* (Mani, 1941: 28) (**comb. n.** from *Litomastix*) (Bangladesh), *desantisi* Annecke & Mynhardt (1974: 32) (Australia), *fasciatum* (Girault, 1913e: 113) (**comb. n.** from *Pseudencyrtella*) (Australia), *insularis* (Timberlake, 1941: 230) (**comb. n.** from *Mesencyrtus*) (Marquesas Is.), *javae* (Girault, 1917a: 5)

(**comb. n.** from *Paracopidosomopsis*) (India, Java), *javensis* (Girault, 1919b: 56) (**comb. n.** from *Copidosomopsis*) (Java), *koehleri* Blanchard; Annecke & Mynhardt (1974: 32) (India), *lepidopterophagus* (Girault, 1915a: 107) (**comb. n.** from *Zaomencyrtus*) (Australia), *longiartus* (Girault, 1932a: 1) (**comb. n.** from *Liothorax*) (Australia), *lotae* (Girault, 1923a: 50) (**comb. n.** from *Parasteropaeus*) (Australia), *lucetius* (Walker, 1839: 36) (**comb. n.** from *Encyrtus*) (Australia), *maculatum* (Ishii; Tachikawa, 1963: 199) (Australia, New Zealand), *manilae* (Ashmead, 1904a: 14) (**comb. n.** from *Coccidencyrtus*) (Philippines), *parkeri* (Girault, 1932a: 2) (**comb. n.** from *Helegonatopus*) (Australia), *perseverans* (Girault, 1915a: 116) (**comb. n.** from *Paracaenocercus*) (= *Angeliconana eja* Girault, 1922e: 150 **syn. n.**) (Australia), *salacon* (Walker, 1839: 37) (**comb. n.** from *Encyrtus*) (Australia), *shakespearei* Girault (1923d: 2) (Australia), *truncatellum* (Dalman; = *aestivalis* Mercet, 1921: 447) (Hawaiian Is.), *variventris* (Girault, 1925b: 94) (**comb. n.** from *Mesocopidosomyia*) (Australia) and *walshi* (Mercet, 1922a: 154) (**comb. n.** from *Litomastix*) (Java), also much undetermined material from throughout the region, probably containing many undescribed species (BMNH, BPBM, QM, ANIC, CNC, UCNM, HC, GC).

BIOLOGY. Polyembryonic parasites of larvae of Lepidoptera.

COMMENTS. The single extant male syntype of *Encyrtus salacon* Walker (BMNH) is here designated LECTOTYPE.

There are two male syntypes of *Encyrtus lucetius* Walker in the BMNH. One of them is here designated LECTOTYPE and has been labelled as such.

There has been much discussion concerning the maintaining of *Copidosoma* and *Litomastix* as two separate genera. The majority of workers in North America have taken the view that they should be considered synonymous, but most workers in Europe have regarded them as distinct. Certainly the type-species of the respective genera are very different and in some regions of the world (e.g. Europe) the genera can be separated easily and with confidence. However, it has been our experience, whilst examining material from throughout the world, that the two genera are impossible to separate. The usual combination of characters for separating them (obliquely truncate solid clava, hypopygium not extending to the apex of the gaster for *Litomastix* and apically rounded or transversely truncate solid or three-segmented clava, hypopygium extending to the apex of the gaster for *Copidosoma*) are not at all reliable. Even by using other characters, e.g. whether the ovipositor is exerted, relative length of marginal vein of forewing, sculpture, general body shape, etc., we have not been able to separate the species into these two recognised genera with any degree of certainty. For example, a species in North America has a well-exserted ovipositor and hypopygium reaching the apex of the gaster but with all other characters typical of *Litomastix*; a species from India has the antenna typical of *Copidosoma* but the rest of the body like *Litomastix*, and so on. With this in mind we are following the majority of the North American workers in considering the two genera as synonymous. This decision is further enhanced by the fact that where their biology is known, all species are polyembryonic parasites of Lepidoptera, and all species have a characteristic square arrangement of the sensillae at the apex of the stigmal vein of the forewing and the uncus absent (Figs 142, 183). This latter character is not known to us in any other encyrtid group except some members of the tribes Dinocarsini and Anagyrini (Tetracneminae) and Rhinoencyrtini (Encyrtinae).

Copidosoma is placed in the tribe Copidosomatini, subtribe Copidosomatina (Encyrtinae).

COPIDOSOMOPSIS Girault

(Key couplet: 69. Figs 29, 30)

Copidosomopsis Girault, 1915a: 94. Type-species: *Copidosomopsis perminutus* Girault, by monotypy.

Pseudolitomastix Eady, 1960a: 667. Type-species: *Pseudolitomastix nacoletiae* Eady, by original designation. [Homonym of *Pseudolitomastix* Risbec, 1954.] **Syn. n.**

Pentalitomastix Eady, 1960b: 173. [Replacement name for *Pseudolitomastix* Eady.] **Syn. n.**

DISTRIBUTION AND SPECIES. Four species, Neotropical, Palaearctic, Australasian; two from

review area: *nacoleiae* (Eady, 1960a: 667) (**comb. n.** from *Pseudolitomastix*) (India, Singapore, Malaysia, Indonesia, Papua New Guinea) and *perminutus* Girault (1915a: 94) (Australia), also undetermined material from Papua New Guinea and Australia (BMNH, AMNH).

BIOLOGY. Polyembryonic parasites of larvae of Pyralidae and Tortricidae (Lepidoptera).

COMMENTS. The holotype of *Copidosomopsis perminutus* (QM) has the body mounted on a card and the head, one forewing and antennae mounted on a slide. Girault did not mention in his original description how many segments the funicle of *Copidosomopsis* consisted of, except by inference when he compared it with *Copidosomyia*, which has a six-segmented funicle. Also in his unpublished manuscript (QM) he states that the funicle is six-segmented. However, examination of the parts on the slide reveals the following present: five funicle segments and a pedicel, four funicle segments plus clava, four funicle segments plus pedicel and scape and two funicle segments plus a clava. This adds up to 15 funicle, two pedicel, one scape and two clava segments i.e. parts of at least three antennae present. In no case is there a complete, intact funicle with six segments. It is almost certain that Girault drew up his description from the parts on this slide and assumed that the funicle was six-segmented. However, amongst material collected recently by Bouček is a specimen which agrees more or less exactly with the parts of the holotype of *perminutus*. This specimen has only five funicle segments. Since the biology of *perminutus* is the same as *nacoleiae* (both species have been reared from pyralid larvae), we feel certain that the funicle of this species is only five-segmented and that Girault was erroneous in believing it to be six-segmented. The wing venation, hypopygium and other morphological characters of *perminutus* are very much the same as those of *nacoleiae*, therefore we have no hesitation in synonymising *Pentalitomastix* with *Copidosomopsis*. Thus the following extra-limital species are also transferred to *Copidosomopsis* from *Pentalitomastix*: *arenicola* Trjapitzin, *bohemicus* Hoffer and *plethoricus* Caltagirone (all **comb. n.**).

The genus is very near to *Copidosoma* (tribe Copidosomatini, subtribe Copidosomatina) and can be separated from it by having a five-segmented funicle. It is also very close to *Raffaellia*, from which it can be separated using the characters given in the key.

COPIDOSOMYIA Girault

(Key couplet: 355. Fig. 193)

Copidosomyia Girault, 1915a: 99. Type-species: *Copidosomyia cinciventris* Girault, by original designation.

Acridencyrtus Subba Rao, 1979: 144. Type-species: *Acridencyrtus ambiguous* Subba Rao, by original designation. **Syn. n.**

Neochrysoophilus Tachikawa, 1979b: 175. Type-species: *Neochrysoophilus bhimolporae* Tachikawa, by original designation. **Syn. n.**

DISTRIBUTION AND SPECIES. Three species, Oriental and Australasian: *ambiguous* (Subba Rao, 1979: 145) (**comb. n.** from *Acridencyrtus*) (India, Bangladesh), *bhimolporae* (Tachikawa, 1979b: 174) (**comb. n.** from *Neochrysoophilus*) (Thailand) and *cinciventris* Girault (1915a: 99) (Australia), also undetermined material from Hong Kong (BPBM).

BIOLOGY. Parasites of Chrysopidae (Neuroptera). Records of this genus having been reared from Pseudococcidae (Homoptera) are probably erroneous.

COMMENTS. The genus is very close to *Homalotylus* (tribe Homalotylini, subtribe Homalotyliina) but can be separated by the remarkable shape of the head (see Tachikawa, 1979b) and lack of notaular lines on the mesoscutum.

COWPERIA Girault

(Key couplets: 352, 421. Fig. 191)

Cowperia Girault, v. 1919a: 167. Type-species: *Cowperia punctata* Girault, by monotypy.

Aminellus Masi, ix. 1919: 286. Type-species: *Aminellus niger* Masi, by monotypy. **Syn. n.**

DISTRIBUTION AND SPECIES. Four species, Palaearctic, Oriental, Australasian; three from review area: *indica* (Kerrich, 1963: 362) (**comb. n.** from *Aminellus*) (India, Sri Lanka), *punctata* Girault (1919a: 167) (Singapore) and *sumatraensis* (Kerrich, 1963: 363) (**comb. n.** from *Aminellus*), also further undetermined material, including at least one undescribed species, from India and Sri Lanka to Borneo (BMNH, BPBM, UCR, USNM).

REFERENCE. Revision: Kerrich (1963).

BIOLOGY. Parasites of coccinellid (Coleoptera) larvae which are predaceous on Pseudococcidae (Homoptera).

COMMENTS. The single extant syntype female of *Cowperia punctata* Girault is here designated LECTOTYPE (BMNH). It is very close to *Cowperia indica* but differs in having a slightly flatter scutellum which is more conspicuously carinate laterally and relatively more transverse funicle segments.

Placed in the tribe Bothriothoracini, subtribe Aminellina by Trjapitzin (1973b). It can be separated from the other included genus, *Amicencyrtus*, by the more distinctly convex scutellum (see also Hayat, 1981b: 17).

CREMESINA gen. n.

(Key couplets: 83, 147. Figs 35, 36, 80, 304, 313)

Type-species: *Cremesina aquilonaris* sp. n. Gender: feminine.

♀. *Head*. In facial view a little broader than long and in profile about twice as long as broad and anteriorly more or less gradually and evenly curved. Eye with posterior margin straight, about two-thirds longer than broad and with numerous short setae and reaching or nearly reaching occipital margin which is sharp. Malar space about one-third length of eye, with sulcus absent or present. Frontoververtex slightly less than half head width; ocelli forming a slightly acute to slightly obtuse angle, posterior ocellus separated from occipital margin by a little less than its own major diameter and from eye margin by about its own major diameter. Antennal scrobes shallow, not meeting dorsally and reaching about half way from antennal toruli to anterior ocellus; antennal torulus separated from mouth margin by about half its length and from other torulus by about its own length, its dorsal margin about level with ventral eye margin; clypeal margin broadly excised between toruli. Antennal scape broadened and flattened about two to two and one-half times as long as broad and a little longer than minimum width of frontoververtex, pedicel conical, a little longer than any of the funicle segments (except perhaps the first) which are cylindrical and all clearly longer than broad, the first a little longer and narrower than the sixth, funicle six-segmented; clava three-segmented, a little less than half as long as funicle and with apex more or less rounded, the sutures more or less parallel, the outer suture slightly oblique; longitudinal sensillae on all flagellar segments. Frontoververtex with very fine, transversely rugose sculpture of silky appearance and clothed with fairly dense short white setae. Mandible narrow with two apical teeth, maxillary palpus four-segmented, labial palpus probably two- or possibly three-segmented.

Thorax. In side view moderately deep with metapleurum and propodeum broadly in contact with hind coxa, dorsally with mesoscutum and scutellum flat. In dorsal view (Fig. 35) pronotum with posterior margin slightly concave; visible part of mesoscutum a little more than twice as broad as long with notaular lines absent; axillae meeting, scutellum a little broader than long and about as long as to one-third longer than mesoscutum and with apex acute; propodeum medially not more than about one-tenth as long as scutellum. Dorsum of thorax with similar sculpture to frontoververtex, silky in appearance and covered with numerous short, appressed setae. Macropterous species (Fig. 80) with forewing centrally strongly infusate, occasionally with only the basal and apical quarters hyaline, wing a little over two and one-half times as long as broad, linea calva interrupted just below middle and closed near posterior margin of wing, filum spinosum present, submarginal vein with an apical hyaline break, marginal vein about three times as long as broad, clearly longer than the short postmarginal and about as long as the stigmal; costal cell about 20 times as long as broad and with a single line of setae dorsally in distal half. Hindwing hyaline and about three-quarters as long as forewing and a little over four times as long as broad, with marginal fringe about one-quarter as long as maximum wing width. Brachypterous species (Fig. 304) with forewing reaching about half way along gaster, the apex truncate, about four times as long as broad, venation nearly reaching apex, linea calva absent; hindwing about two-thirds length of forewing, about eight times as long as broad,

gradually tapering towards apex and with venation reaching apex. Mid tibial spur nearly as long as basal mid tarsal segment.

Gaster. Slightly longer than thorax, cercal plates in anterior half, paratergites present, last tergite a little longer to one-half longer than mid tibia, hypopygium reaching apex of gaster, ovipositor not exerted and about one-quarter to one-third longer than mid tibia, gonostyli fused to second valvifers and about one-fifth to one-sixth length of ovipositor.

♂. Differs from female as follows. Eye a little smaller, about one-half longer than broad and a little separated from occipital margin; malar space about two-fifths to one-half length of eye; malar sulcus present. Frontoververtex a little more than half head width; posterior ocellus separated from eye margin by about its own major diameter to much more than its own major diameter, antennal scrobes more or less meeting dorsally; antennal torulus separated from mouth margin by a little less than its own length and from other torulus by less than to about its own length, its ventral margin only a little below or about level with ventral margin of eye; antennal scape stout, about four times as long as broad and about one-third shorter than minimum width of frontoververtex, pedicel conical, subquadrate, a little longer than broad and clearly shorter than any funicle segments which are all longer than broad, setae on flagellum at least about twice as long as maximum diameter of segments, longitudinal sensillae on all flagellar segments, scale-like sensillae on sixth funicle segment and base of clava. Forewing entirely hyaline and about two and one-half times as long as broad, filum spinosum absent; hindwing about five times as long as broad. Gaster about as long as thorax; genitalia with digiti about one-tenth to one-twentieth as long as aedeagus and without hooks, aedeagus about one-half as long as mid tibia or twice as long as mid tibial spur.

COMMENTS. The genus belongs to the Anagyrini, subtribe Anagyrina (Tetracneminae) and is probably closest to *Anagyrus*. It can be separated from this genus by the pattern of infuscation of the forewing and the presence of the filum spinosum in the fully winged species. The latter is apparently very rare in the Tetracneminae.

Cremesina aquilonaris sp. n.

(Figs 305–313)

♀. Length: 1.02–1.59 mm (holotype, 1.44 mm).

Colour. Head and thorax generally reddish; antenna with radicle dark brown, scape dark brown and on outer face with a short white stripe along its ventral margin to about one-quarter along margin, dorsal margin white, apical quarter white with extreme apex dark brown, inner face similar but white stripe along dorsal margin wider and brown areas in centre often pale yellowish-brown; pedicel with basal half dark brown and apical half white, funicle segments two to five white, other flagellar segments dark brown (Fig. 306), occasionally fifth funicle segment also dark brown or segments two to five pale dusky brownish white; tegula white with apex dark brown; occasionally posterior margin of propodeum laterally dark; gaster completely reddish as in thorax but usually mixed with dark brownish to a lesser or greater extent; legs including fore and mid coxae yellowish white, hind coxa usually reddish mixed with brownish, all femora occasionally slightly dusky as well as fore tibia and bases of mid and hind tibiae outwardly, foretarsus testaceous yellow, mid and hind pretarsi dark brown; forewing infuscate (as in Fig. 80) except for a distinct hyaline break immediately distal to infuscate area.

Head. Setae on eyes generally dark and conspicuous, particularly in larger specimens, in smaller specimens they may be pale, short and inconspicuous; malar sulcus absent; ocelli forming a distinctly obtuse angle; antennal toruli separated from each other by very slightly more than their own lengths. Relative measurements (holotype): head width (facial view) 74, head length 65, minimum frontoververtex width 32, malar space 13, eye length 51, eye width 30, POL 16, OOL 6, scape length 35, other proportions of antenna as in Fig. 306.

Thorax. Scutellum a little longer to nearly one-third longer than mesoscutum, forewing fully developed. Relative measurements of forewing (holotype): length 68, width 27, other proportions as in Fig. 305; of hindwing: length 50, width 12. Sculpture of mesoscutum Fig. 307.

Gaster. Relative lengths (paratype): ovipositor 52, gonostylus approx. 9, last tergite 47, [mid tibia 38]. Ovipositor as in Fig. 308, hypopygium as in Fig. 309.

♂. Length: 0.67–1.05 mm.

Differs from female as follows. *Colour*. Head, thorax and gaster generally dark brown and orange or yellowish orange along margins of eyes and face below top of antennal scrobes, slightly dusky on interantennal prominence and dark brown on lower part of gena near base of mandible; legs and tegula

more or less as for female except hind coxa almost totally dark brown; sides of thorax mixed with orange, particularly around perimeter of mesopleurum; antenna with scape dusky white basally, with a broad dark brown median band and apical one-third or so more or less yellowish brown, pedicel and flagellum yellowish with base of pedicel darker mixed with brown.

Head. Setae on eyes generally less conspicuous than in female; ventral margin of antennal torulus slightly below lower eye margin, toruli separated by about their own lengths, scale-like sensillae present on clava. Relative measurements (paratype): head width (facial view) 60, head length 53, minimum frontovertex width 33, malar space 13, eye length 33, eye width 22, POL 15, OOL 7, scape length 26, proportions of antenna as in Fig. 310.

Thorax. Base of forewing and venation as in Fig. 313.

Gaster. Relative lengths (paratype): aeadeagus 48, [mid tibial spur 19]; genitalia as in Figs 311, 312.

DISTRIBUTION. India.

BIOLOGY. Unknown.

MATERIAL EXAMINED

Holotype ♀, **India:** Uttar Pradesh, Aligarh, 8–10.xi.1979 (*J. S. Noyes*) (BMNH).

Paratypes. **India:** 11 ♀, 7 ♂, same date as holotype; 1 ♀, Uttar Pradesh, Aligarh, 24.i.1978 (*M. Hayat*); 1 ♀, Uttar Pradesh, Aligarh, 10.x.1979 (*M. Verma*); 1 ♀, Uttar Pradesh, Aligarh, 13.xii.1979 (*M. Hayat* & *M. Verma*); 1 ♀, Uttar Pradesh, Aligarh, 10.viii.1980 (*M. Hayat*); 1 ♀, Uttar Pradesh, Aligarh, 8.iii.1981 (*M. Hayat*); 21 ♀, 1 ♂, Delhi, IARI area, x.1979 (*Z. Bouček*); 11 ♀, 10 ♂, Uttar Pradesh, Dehra Dun, x.1979 (*Z. Bouček*) (BMNH, HC, USNM, UCR, ZI, PPRI).

COMMENTS. A further three species from India and one from Cook Is., the latter species differing in having brachypterous hyaline forewings. The species can be separated in the female by general coloration, the relative distance between the antennal toruli, the relative lengths of the funicle segments, the relative width of the frontovertex, the angle formed by the ocelli, the presence or absence of a malar sulcus, the extent of the infuscation and the relative lengths of the forewings and the relative length of the scutellum to the mesoscutum; in the male they can be separated by the relative distance that separates the antennal toruli, their position in relation to the lower eye margin, the relative width of the frontovertex; the presence or absence of scale-like sensillae on the clava and the relative length of the digiti of the genitalia.

CRYPTANUSIA Girault

(Key couplet: 119)

Cryptanusia Girault, 1917f: 14. Type-species: *Cryptanusia albiclava* Girault, by original designation.

Anusoidea Girault, 1926c: 128. Type-species: *Anusoidea aureiscutellum* Girault, by monotypy.

DISTRIBUTION AND SPECIES. Seven species, all Australasian: *albiclava* Girault; Gordh & Trjapitzin (1981: 15) (Java), *aureiscutellum* (Girault, 1926c: 128) (Australia), *comperei* (Timberlake, 1929: 11) (Australia), *gigantea* (Girault, 1917g: 138) (**comb. n.** from *Xenanusia*) (Australia), *luzonica* (Gordh, 1974: 203) (Philippines), *phoonae* (Tachikawa, 1968: 117) (Singapore) and *varia* (Girault, 1927b: 310) (Australia).

BIOLOGY. Parasites of Pseudococcidae (Homoptera).

COMMENTS. It is quite possible that *aureiscutellum*, *comperei*, *gigantea* and *varia* are synonymous since they differ only in colour and slightly in the arrangement of the setae proximal to the linea calva. A series of specimens recently collected in Australia (BMNH) exhibits a large degree of variation in these characters.

The genus is placed in the tribe Anagyriini, subtribe Anusiina (Tetracneminae) by Gordh & Trjapitzin (1981: 17). In our view the group to which this genus belongs (including *Cyrtocoryphes*, *Parectromoidella*, *Epanusia* and *Xenanusia*) might be better placed within the Dinocarsiini (or Dinocarsina if it is regarded as a subtribe of the Anagyriini). *Cryptanusia* can be separated from related genera (see above) by the characters given in the key.

CYRTOCORYPHES Timberlake

(Key couplet: 227. Figs 133, 316)

Cyrtocoryphes Timberlake, 1926: 5. Type-species: *Cyrtocoryphes viridiceps* Timberlake, by monotypy.DISTRIBUTION AND SPECIES. One species, Fiji only: *viridiceps* Timberlake (1926: 8).

BIOLOGY. Unknown.

COMMENTS. The genus is close to *Paraectromoidella* (see also comments under *Cryptanusia*) from which it can be separated by the characters given in the key.**DIAPHORENCYRTUS** Hayat

(Key couplets: 313, 443, 526)

Diaphorencyrtus Hayat, 1981a: 18. Type-species: *Aphidencyrtus aligarhensis* Shafee, Alam & Agarwal, by original designation.DISTRIBUTION AND SPECIES. Three species, all Oriental and possibly synonymous: *aligarhensis* (Shafee, Alam & Agarwal, 1975: 91) (India), *diaphorinae* (Lin & Tao, 1979: 117) (**comb. n.** from *Psyllaephagus*) (Taiwan) and *diaphorinae* (Myartseva & Trjapitzin, 1978: 793) (**comb. n.** from *Aphidencyrtus*) (Vietnam), also one undescribed species from Hong Kong (BMNH).

BIOLOGY. Parasites of nymphs of Psyllidae (Homoptera).

COMMENTS. The genus is most probably best placed in the tribe Microteriyini, subtribe Syrphophagina (Encyrtinae) and can be separated from related genera (see comments under *Coccidoctonus*) by the characters given in the key.**DIASULA** gen. n.

(Key couplet: 343. Figs 158, 314, 315)

Type-species: *Liothorax glabriscutellum* Girault. Gender: feminine.

♀. *Head*. In frontal view slightly wider than long and in side view a little less than twice as long as broad and more or less gradually and evenly curved anteriorly but a little more strongly so above top of antennal scrobes. Eye almost naked, with sparse, very inconspicuous pale setae, each clearly shorter than the diameter of a facet; posterior margin of eye very slightly concave, eye about one-third longer than broad and reaching occipital margin which is sharply carinate, particularly behind ocelli. Malar space slightly longer than one-third length of eye, with sulcus present; mouth opening relatively broad, about two-thirds as wide as head. Frontoververtex about one-third head width; ocelli more or less forming a right angle, relatively large, the posterior ones very close to eye margin but separated from occipital margin by about one and one-half times their own major diameters. Antennal scrobes fairly shallow and short, only about as long as toruli, meeting dorsally, reaching to about one-third way from toruli to anterior ocellus; antennal torulus separated from mouth margin by about its own length and from other torulus by slightly less than its own length, its dorsal margin about half its length above ventral level of eyes; clypeus broadly but shallowly concave, naked along mouth margin. Antennal scape clearly longer than width of frontoververtex, subcylindrical, about five to six times as long as broad; pedicel conical, about two-fifths length of scape, subequal in length or a little longer than any of the funicle segments, all of which are cylindrical and at least slightly longer than broad; clava three-segmented, apically rounded with sutures parallel and about twice as long as any funicle segment and not or hardly broader; longitudinal sensillae on all flagellar segments; longest setae a little longer than diameter of segments. Frontoververtex fairly smooth and polished behind ocelli; between ocelli with very shallow, raised, reticulate sculpture, below this with very shallow, raised, transverse, squamiform-reticulate sculpture, this becoming more longitudinally elongate between scrobes and eyes and on lower parts of face; setae on head sparse, dark and not very conspicuous although each a little longer than the diameter of an ocellus. Mandible broad with three acute teeth; maxillary palpus four-segmented; labial palpus three-segmented.

Thorax. In side view fairly deep with mesoscutum only a little convex, but scutellum fairly strongly so; metapleurum together with propodeum only narrowly in contact with hind coxa. Pronotum in dorsal view

more or less triangular with its posterior margin slightly concave; visible part of mesoscutum about one and one-half times as broad as long, with posterior margin slightly convex, notaular lines absent; axillae meeting; scutellum very convex, clearly longer than broad with its apex narrow and rounded; propodeum medially quite long, but not more than one-sixth as long as scutellum. Mesoscutum and scutellum with very shallow, raised, squamiform-reticulate sculpture, sculpture of axillae similar but finer, anterior one-third or so of scutellum with similar sculpture to mesoscutum but shallower, gradually becoming more shallow posteriorly so that apical half of scutellum is almost completely smooth and polished; mesopleurum smooth; propodeum smooth save for a very shallow incomplete carina medially; mesoscutum with a few scattered, fairly long, dark setae; scutellum with about two dozen long conspicuous setae including two pairs of long erect setae subapically. Forewing hyaline, about two and one-half times as long as broad; linea calva neither interrupted nor closed; basal cell sparsely hairy; filum spinosum present; submarginal vein with an apical hyaline break, parastigma not swollen; costal cell about 12 to 13 times as long as broad, with only a few setae dorsally in its apical half or so; marginal vein about four to five times as long as broad, about one and one-half times as long as stigmal which is subequal in length to postmarginal vein; venation yellowish. Hindwing hyaline, about three-quarters as long as broad, with marginal fringe about one-seventh as long as width of hindwing. Mid tibial spur about as long as basal mid tarsal segment.

Gaster. Clearly longer than thorax and apically acute; cercal plates in basal one-third; ovipositor a little exerted, exerted part less than one-tenth length of gaster; hypopygium reaching from about one-third to nearly three-quarters along gaster; last tergite about as long as mid tibia.

♂. Unknown.

COMMENTS. *Diasula* is possibly related to *Helegonatopus* (Encyrtinae, Chalceryini) since the mandible has three acute teeth, the scutellum is convex and the wing venation is yellow. However, it can be easily separated from this and related genera by the very sharp occipital margin, long marginal vein and very shiny scutellum.

Diasula glabriscutellum (Girault) comb. n.

(Figs 158, 314, 315)

Liothorax glabriscutellum Girault, 1932a: 1. LECTOTYPE ♀, AUSTRALIA (QM), here designated [examined].

♀. Length: 2.08–2.22 mm.

Colour. Head and thorax metallic green with some purple reflections, particularly between ocelli and occipital margin and on lower parts of face, sides of thorax orange-brown to dark purplish brown; antennal pedicel and flagellum dark brown, scape, palpi and legs, excluding mid coxae, pale yellow, mid coxa dark brown; wings hyaline, venation yellow; gaster towards base ventrally metallic green, remainder of dorsum shining purple, ovipositor sheaths dark brown.

Head. Relative measurements (Australian specimen): head length 84, head width (frontal view) 89, head width (side view) 51, minimum frontovertex width 31, POL 14, OOL 1.5, malar space 21, eye length 59, eye width 45, scape length 47, other proportions of antenna as in Fig. 315, mandible as in Fig. 314.

Thorax. Base of forewing as in Fig. 158. Relative measurements (Australian specimen): forewing length 278, forewing width 108, hindwing length 198, hindwing width 53.

Gaster. Hypopygium reaching about three-quarters along gaster. Relative lengths (Australian specimen): last tergite 110, [mid tibia 111].

♂. Unknown

DISTRIBUTION. Australia, Philippines.

BIOLOGY. Unknown.

MATERIAL EXAMINED

Lectotype ♀, **Australia**: Queensland, Nelson (*A. P. Dodd*).

Australia: 1 ♀, Queensland, 15 km SE. of Nambour, 6.xi.1976 (*Z. Bouček*) (compared with lectotype) (BMNH). **Philippines**, 1 ♀, Mt Montalban, Rizal Wa-Wa Dam, 150–200 m, 23.iii.1965 (*L. M. Torrevillas*) (BPBM).

COMMENTS. The single extant syntype of *Liothorax glabriscutellum* Girault (1932a: 1) in the Queensland Museum has the body mounted on a card and labelled '*Liothorax glabri-*

scutellum Gir. ♀ type'; the head and right forewing are on a separate slide labelled '*Liothorax glabriscutellum* Girault ♀ Type'. It is here designated lectotype. The Australian specimen was compared with the lectotype by one of us (JSN) during a visit to Brisbane in 1980.

Two other species are provisionally placed in this genus: *Diasula semiargentipes* (Girault, 1915a: 105) (comb. n. from *Parasyrphophagus*) (Australia) and *Diasula homeri* (Girault, 1935: 3) (comb. b. from *Parasyrphophagus*) (Australia), and should run here in the key.

DIVERSINERVUS Silverstri

(Key couplets: 87, 98)

Diversinervus Silvestri, 1915a: 301. Type-species: *Diversinervus elegans* Silvestri, by original designation. *Cheiloneuroides* Girault, 1915a: 96. Type-species: *Cheiloneuroides bicristatus* Girault, by original designation.

DISTRIBUTION AND SPECIES. Eleven species, cosmopolitan; five from review area: *cervantesi* (Girault, 1933: 4) (Australia, Malaysia, Samoa), *elegans* Silvestri (1915a: 304) (India, Australia, Fiji, Hawaiian Is.), *intermedius* Hayat, Alam & Agarwal (1975: 43) (India), *madgaensis* Hayat, Alam & Agarwal (1975: 41) (India) and *paradisicus* (Motschulsky, 1863: 52) (Sri Lanka), also undetermined material from New Caledonia (BPBM).

REFERENCE. Key to world species: Hayat *et al.* (1975: 39–41); Rosen & Alon (1983).

BIOLOGY. Parasites of Coccidae (Homoptera).

COMMENTS. The only species not included in the key by Hayat *et al.* is *cervantesi* but this has been included by Rosen & Alon. It can be easily recognised since it is the only brachypterous species known in the genus.

The genus is placed in the tribe Cheiloneurini (Encyrtinae) by Trjapitzin (1973b), but the forewing venation suggests a strong link with some genera of the Cerapterocerini, e.g. *Anicetus*.

DODDANUSIA gen. n.

(Key couplet: 131. Figs 66, 317–321)

Type-species: *Anusia viridiflava* Dodd. Gender: feminine

♀. *Head*. In facial view nearly one-third broader than long, in side view a little less than twice as long as broad and more or less evenly curved anteriorly except below top of antennal scrobes where it is almost straight. Eye with fairly conspicuous translucent setae, each a little longer than the diameter of a facet, posterior margin of eye straight, eye only very slightly longer than broad, reaching occipital margin which is rounded, but not strongly so. Malar space about one-half to three-fifths length of eye, with sulcus absent. Frontovortex less than one-quarter as wide as head; ocelli forming an acute angle of about 45–70°, the posterior ones clearly closer to eye margin than to occipital margin, separated from the latter by about their own diameters. Antennal scrobes broadly semi-circular, meeting dorsally and more or less sharply margined dorsally, reaching about one-third way from antennal toruli to anterior ocellus; antennal torulus separated from mouth margin by slightly more than its own length and from other torulus by about one and one-half times its own length, its dorsal margin clearly below the ventral level of the eyes; clypeus broadly and shallowly emarginate. Antennal scape (Fig. 318) much longer than minimum width of frontovortex and distinctly broadened and flattened, about twice as long as broad, pedicel conical, about one-quarter length of scape and clearly longer than any of the funicle segments; funicle six-segmented, cylindrical, clearly broadening distally; clava two- or three-segmented, with a strong oblique truncation, nearly as long as funicle; longitudinal sensillae on fifth and sixth funicle segments and clava; longest setae clearly shorter than diameter of first funicle segment, funicle segments and basal segment of clava with setae flattened and scale-like. Frontovortex near ocelli with shallow to fairly deep polygonal reticulate sculpture, above scrobes similar but transversely elongate or almost entirely smooth and shiny; between scrobes and eyes moderately deep, polygonally reticulate sculpture, this becoming a little shallower and more longitudinally elongate on genae; setae on frontovortex translucent or dark, about as long as the diameter of an ocellus.

Mandible with one tooth and a broad truncation (Fig. 319); maxillary palpus four-segmented, labial palpus three-segmented.

Thorax. In side view moderately robust but dorsally very flat; the mesopleurum enlarged and more or less touching basal segment of gaster and thus clearly separating the hind coxa from the metapleurum and propodeum. In dorsal view posterior margin of propodeum broadly and shallowly concave; visible part of mesoscutum about twice as broad as long with notaular lines absent, its posterior margin almost straight; axillae meeting; scutellum flat, triangular and slightly broader than long; propodeum medially a little less than one-fifth length of scutellum. Dorsum of thorax with shallow, raised, squamiform-reticulate sculpture, mesopleurum with raised reticulate sculpture of fine mesh medially and longer mesh posteriorly, anteriorly rather more irregular and longitudinally elongate; propodeum with shallow, raised irregular sculpture; setae on dorsum of thorax dark, sparse and of moderate length. Forewing generally suffused pale brown and convex dorsally (as in *Discodes*), about twice as long as broad; linea calva not interrupted but closed on dorsal surface by one or two lines of setae near posterior margin of wing; filum spinosum present but in posterior half of wing (Fig. 66); submarginal vein with an indistinct apical hyaline break, parastigma not swollen; costal cell about 10 or 11 times as long as broad, with one or two lines of setae dorsally along its length; marginal vein about four to five times as long as broad, about three times as long as postmarginal and a little longer than, to about same length as stigmal (Fig. 317); setae on dorsal surface of wing fairly inconspicuous and short. Hindwing slightly longer than three-quarters length of forewing, about three times as long as broad, with marginal fringe about one-sixth as long as width of wing. Mid tibial spur a little shorter than basal mid tarsal segment.

Gaster. A little shorter than thorax with hypopygium extending to about three-quarters along venter; ovipositor not exerted; last tergite a little shorter than mid tibia; paratergites absent; ovipositor (Fig. 321) about as long as mid tibia; gonostyli free, about one-sixth as long as ovipositor; hypopygium as in Fig. 320.

♂. Unknown.

COMMENTS. This genus should probably be placed in the Microteryini (Encyrtinae), subtribe Microteryina and can be separated easily from all other related genera by the strongly obliquely truncate antennal clava, scale-like setae on the flagellum, and presence of a filum spinosum in posterior half of forewing.

Doddanusia viridiflava (Dodd) comb. n.

Dodd's original (1924) description is probably sufficient to recognise this species. It can be separated from a second species from the mainland of Australia: Queensland (BMNH) by having the antennal scrobes partly metallic green, the frontovertex at its narrowest point about one-fifth head width, malar space about one-half length of an eye, ocelli forming an angle of about 45° and antennal scape more clearly triangular in shape. The species from the Australian mainland has the scrobes non-metallic, frontovertex about one-quarter head width, ocelli in an angle of about 65–70°, malar space about three-fifths as long as an eye and antennal scape subrectangular in shape (Fig. 318). Figs 66, 317–321 are of this second undescribed species.

DISTRIBUTION. Australia (Queensland and Norfolk Is.).

BIOLOGY. Unknown.

DOLIPHOCERAS Mercet

(Key couplets: 165, 174, 221, 277. Figs 97, 98, 175)

Doliphoceras Mercet, 1921: 91. Type-species: *Pholidoceras integralis* Mercet, by original designation.

Rhopomorphus Ghesquière, 1958: 25. Type-species: *Rhopomorphus varleyellus* Ghesquière, by original designation.

DISTRIBUTION AND SPECIES. Twelve species, Palaearctic, Afrotropical, Oriental, Australasian and Pacific; five from review area: *fraternus* (Perkins, 1910: 653) (comb. n. from *Anagyryus*) (Hawaiian Is.), *gracilis* Hayat (1970a: 114) (India), *nigricans* (Perkins, 1910: 653) (Hawaiian Is.), *punctifrons* (Timberlake, 1941: 219) (comb. n. from *Anagyryus*) (Marquesas Is.) and

tantaleus (Perkins, 1910: 654) (**comb. n.** from *Anagyris*) (Hawaiian Is.), also undetermined material from Nepal, Hong Kong, Fiji and Australia (BMNH, BPBM).

BIOLOGY. Parasites of Pseudococcidae (Homoptera).

COMMENTS. The genus is placed in the subtribe Rhopina of the tribe Anagyrini (Tetracneminae) by Trjapitzin (1973a), which is, without doubt, incorrect. *Doliphoceras* is extremely close to *Anagyris* (subtribe Anagyrina) and very probably should be considered synonymous, but for the present we are maintaining the two genera as distinct (see comments under *Anagyris*).

***ECHTHROBACCELLA* Girault**

(Key couplet: 241)

Echthrobaccella Girault, 1915a: 113. Type-species: *Echthrobaccella argentinotata* Girault, by original designation.

DISTRIBUTION AND SPECIES. One species, Australia only: *argentinotata* Girault (1915a: 113).

BIOLOGY. Unknown.

COMMENTS. Related to *Cheiloneurus* (Encyrtinae, tribe Cheiloneurini) from which it can be separated by the apparent presence of notaular lines in the extreme anterior part of the mesoscutum, dorsum of thorax with fine punctate sculpture of silky appearance and forewing having dense setae throughout basal cell, submarginal vein not bent downwards subapically, a characteristic infusate pattern, and the distinctive coloration of the thorax (see Girault, 1915a: 113).

***ECHTHROGONATOPUS* Perkins**

(Key couplet: 349, 455, 470, 527. Figs 192, 223, 224)

Echthrogonatopus Perkins, 1906: 256. Type-species: *Echthrogonatopus exitiosus* Perkins, by designation of Gahan & Fagan (1923: 48).

DISTRIBUTION AND SPECIES. Four species, Nearctic, Afrotropical, Oriental, Australasian; three species from review area: *exitiosus* Perkins (1906: 256) (Malaysia, Philippines, Fiji, Australia), *nigricornis* (Hayat, 1980: 644) (India) and *parvus* (Hayat, 1980: 643) (India), also undetermined material, including at least one undescribed species, from Bangladesh, Hong Kong, Philippines and Samoa (BMNH, BPBM, GC).

BIOLOGY. Hyperparasites of leafhoppers (Homoptera, Auchenorrhyncha) via Dryinidae (Hymenoptera).

COMMENTS. The genus is best placed in the tribe Cheiloneurini (Encyrtinae) and can be separated from its nearest relatives, *Zaomma*, by the lack of an apical scutellar brush (see also Hayat, 1980: 642–643), and *Hypergonatopus* by the flat dull scutellum and hyaline forewings (the scutellum of *Hypergonatopus* is convex and at least a little shiny and the forewings are darkened).

***ECTOPIOGNATHA* Perkins**

(Key couplet: 187. Figs 112, 322, 323)

Ectopiognatha Perkins, 1906: 254. Type-species: *Ectopiognatha minor* Perkins, by designation of Gahan & Fagan (1923: 49).

DISTRIBUTION AND SPECIES. Two species, both Australian and probably synonymous: *major* Perkins (1906: 255) and *minor* Perkins (1906: 255), also one undetermined specimen, lacking antennae, from Irian Jaya (BPBM).

BIOLOGY. Parasites of eggs of Flatidae and Eurybrachidae (Homoptera).

COMMENTS. Placement of the genus according to Trjapitzin's (1973) classification is difficult, but it most probably belongs in the Microteryini.

ECTROMA Westwood

(Key couplet: 93)

Ectroma Westwood, 1833a: 344. Type-species: *Ectroma fulvescens* Westwood, by monotypy.

Metallon Walker, 1848: 219. Type-species: *Metallon acacallis* Walker, by monotypy.

Pezobius Förster, 1860: 129. Type-species: *Pezobius polychromus* Förster, by monotypy.

DISTRIBUTION AND SPECIES. Twelve described species, Neotropical, Palaearctic, Afrotropical; none found in review area but one undescribed species from India (BMNH).

BIOLOGY. Unknown.

COMMENTS. Dalla Torre (1898: 238) lists *Ectroma dunense* Six (1876) as originating from Batavia in Asia (Indonesia), but it is not included here since this species was described from the Batavia peninsula in the Netherlands.

The mandibles of *Ectroma* are tridentate, although they were erroneously stated to be bidentate by Noyes (1980: 114).

The genus has been placed in the tribe Miraini, subtribe Mayridiina (Encyrtinae) by Trjapitzin (1973b). This is obviously incorrect since *Mira* (and thus the tribe Miraini) belongs in the Tetracneminae whereas *Ectroma* and its relatives belong in the Encyrtinae. We feel sure that *Ectroma* can be accommodated in the Cheiloneurini, and is probably close to *Cheiloneurus*. It can be difficult to separate from brachypterous forms of *Cheiloneurus*, particularly if the latter lacks the usual subapical, scutellar brush (see key).

ENCYRTOIDEA Girault

(Key couplets: 248, 331, 465, 491, 512)

Encyrtoidea Girault, 1923c: 146. Type-species: *Encyrtoidea punctatifrons* Girault, by monotypy.

DISTRIBUTION AND SPECIES. Two species, Australia only: *compressifemur* (Girault, 1923e: 5) (comb. n. from *Nezarhopalus*) and *punctatifrons* Girault (1923c: 146), also two further species from Australia (BMNH).

BIOLOGY. Unknown.

COMMENTS. *Encyrtoidea compressifemur* may be incorrectly placed in this genus since the mandibles are very different from those of *punctatifrons*. The latter species has all three teeth very nearly equal in size, whereas in *compressifemur* the lowest tooth is very much larger than either of the two upper teeth.

The genus is very difficult to place according to Trjapitzin's (1973b) classification of the Encyrtinae. The venation and mandibles suggest an affinity with *Borrowella* (which is here provisionally placed in the Bothriothoracini), but in general appearance it is not unsimilar to some genera of the Microteryini e.g. *Ooencyrtus* and *Syrphophagus*.

ENCYRTUS Latreille

(Key couplets: 99, 373)

Encyrtus Latreille, 1809: 31. Type-species: *Chrysis infida* Rossi, by designation of Latreille (1810: 436).

Eucomys Förster, 1856: 32. Type-species: *Encyrtus swederi* Dalman, by original designation.

Comys Förster, 1856: 144. [Unnecessary replacement name for *Eucomys* Förster.]

Howardia Dalla Torre, 1897: 86. Type-species: *Bothriothorax peckhami* Ashmead, by original designation. [Homonym of *Howardia* Berlese & Leonardi, 1896.]

Howardiella Dalla Torre, 1898: 228. [Replacement name for *Howardia* Dalla Torre.]

Allorhypoideus Brèthes, 1916: 425. Type-species: *Allorhypoideus mirabilis* Brèthes, by original designation.

Prorhypoideus Brèthes, 1921: 80. Type-species: *Prorhypoideus baezi* Brèthes, by original designation.

DISTRIBUTION AND SPECIES. About 90 species currently in the genus *Encyrtus* but only about 40 are correctly placed, cosmopolitan; six species from review area: *albidus* Hayat (1970b: 61) (India), *argenticoxa* (Girault, 1915a: 129) (**comb. n.** from *Eucomys*) (= *Eucomys hibisci* Girault, 1915a: 128 **syn. n.**, = *Eucomys aurantifasciata* Girault, 1915a: 129 **syn. n.**, = *Eucomys argentiscapus* Girault, 1915a: 130 **syn. n.**) (Australia), *infelix* (Embleton, 1902: 223) (Fiji, New Zealand, Hawaiian Is.), *lecaniorum* (Mayr, 1876: 740) (India, Philippines, New Zealand, Hawaiian Is.), *proserpinensis* (Girault, 1915a: 130) (**comb. n.** from *Eucomys*) (= *Eucomys hortensis* Girault, 1915a: 130 **syn. n.**) (Australia) and *saissetiae* (Yasumatsu & Yoshimura, 1945: 33) (**comb. n.** from *Eucomys*) (Mariana Is.), also much undetermined material from throughout the region (BMNH, BPBM, DSIR, CNC, USNM).

REFERENCE. Review of Holarctic species: Sugonjaev & Gordh (1981); key to some species: Hayat (1970b: 59).

BIOLOGY. Parasites of Coccidae (Homoptera).

COMMENTS. We have not seen the holotype of *E. corvinus* Motschulsky (1863: 55), but according to Bouček (pers. comm.) it belongs to the subfamily Telenominae (Proctotrupoidea, Scelionidae).

Placed in the tribe Encyrtini as the sole included genus (Trjapitzin, 1973b). We feel that Trjapitzin's definition of this tribe is probably too narrow and that it should also include those genera of the tribes Eugahaniini, Prionomasticini, Neocladiini and Aethognathini. However, further more detailed study of this group is desirable before this tribal synonymy can be proposed formally.

EOTOPUS gen. n.

(Key couplet: 263. Figs 150, 325–327)

Type-species: *Ericydnus beneficus* Shafee. Gender: masculine.

♀. **Head.** In facial view clearly broader than long and in profile about two-thirds longer than broad and anteriorly more or less gradually and evenly curved. Eye with posterior margin slightly concave, about one-half longer than broad, with dense fairly conspicuous translucent setae and clearly overreaching occipital margin which is more or less rounded. Malar space about one-quarter eye length, with malar sulcus present. Frontovortex about one-third head width; ocelli in a very slightly acute angle, posterior ocellus separated from occipital margin by about twice its diameter and from eye margin by about its own diameter. Antennal scrobes shallow, meeting dorsally and clearly reaching more than half way to anterior ocellus from antennal toruli; antennal torulus separated from mouth margin by a little less than its own diameter and separated from other torulus by nearly one and one-half times its length, its middle being about level with lower eye margins; clypeal margin broadly excised between toruli. Antennal scape much longer than minimum width of frontovortex, cylindrical, slightly wider near base, about five or six times as long as broad, pedicel conical, at least slightly longer than any funicle segment, all of which are longer than wide and slightly widening distally; clava three-segmented, about half as long as funicle, with apex more or less rounded, its sutures almost parallel; longitudinal sensillae on all but the first two flagellar segments. Frontovortex with squamiform-reticulate sculpture, deepest in front of anterior ocellus, fairly shallow behind ocelli and towards lower parts of face where it becomes more longitudinally elongate; frontovortex clothed in sparse, rather inconspicuous, moderately long translucent setae. Mandible tridentate, the upper tooth short and blunt; maxillary palpus three-segmented, labial palpus two-segmented.

Thorax. In side view moderately deep with metapleurum distinct, clearly broadening ventrad and, together with propodeum, broadly in contact with hind coxa and dorsally with both mesoscutum and scutellum flat. In dorsal view posterior margin of pronotum strongly concave; visible part of mesoscutum about one-half broader than long with notaular lines present anteriorly (the area around each notaular line slightly concave), posterior margin of mesoscutum almost straight; axillae meeting medially; scutellum nearly one and one-half times as long as broad and about one-third longer than mesoscutum, with its apex blunt; propodeum medially a little less than one-third length of scutellum. Mesoscutum with moderately

deep, raised, squamiform-reticulate or reticulate sculpture, that on scutellum similar but distinctly more longitudinally elongate; propodeum medially almost smooth, but with some shallow reticulate sculpture; dorsum of thorax with moderately dense short, recumbent, fairly inconspicuous, translucent setae. Forewing hyaline, wing about three times as long as broad; lineae calva not interrupted and nearly closed near posterior margin of wing; filum spinosum absent; venation yellowish, submarginal vein with an inconspicuous apical hyaline break and with parastigma clearly swollen, much broader than proximal two-thirds of submarginal vein; marginal vein about five or six times as long as broad and a little longer than either postmarginal or stigmal veins which are subequal in length; costal cell about 10–11 times as long as broad, with a single line of setae dorsally in distal half. Hindwing about three-quarters as long as forewing, about six times as long as broad, with marginal fringe about one-third maximum wing width. Mid tibial spur shorter than basal mid tarsal segment.

Gaster. A little shorter than thorax, cercal plates at about midway along its length; hypopygium reaching apex of gaster; paratergites not distinct in slide-mounted material available; last tergite a little longer than half length of mid tibia; gonostyli fused to second valvifers and about one-sixth as long as ovipositor which is a little more than half as long as mid tibia.

♂. Differs from female as follows. Eye with posterior margin convex, with setae very sparse and inconspicuous, clearly separated from occipital margin by nearly diameter of posterior ocellus; eye smaller so that malar space is nearly half length of eye and frontovertex clearly more than half head width; ocelli forming an obtuse angle, with posterior ocellus slightly closer to occipital margin than to eye margin, being separated from the latter by a little more than its own diameter; antennal scrobes more broadly semicircular, meeting dorsally and separated from anterior ocellus by not more than its diameter, antennal torulus separated from mouth margin by slightly more than its own length and from other torulus by about its own length, its lower margin only very slightly below ventral margins of eyes; antenna with scape about as long as width of frontovertex and about four times as long as broad, broadest near base, pedicel conical and subquadrate, much less than half length of any of funicle segments which are cylindrical and at least about three times as long as broad, setae on flagellum about four times as long as diameter of segments, clava entire, longer than any funicle segment, longitudinal sensillae on all flagellar segments; sculpture of head clearly shallower than in female, the frontovertex distinctly more shiny. Thorax in profile with mesoscutum slightly concave, in dorsal view scutellum about same length as mesoscutum; propodeum medially about one-fifth length of scutellum; forewing with postmarginal vein a little longer than either marginal or stigmal veins which are subequal in length; costal cell a little narrower than in female; hindwing about two-thirds length of forewing, with marginal fringe about one-half maximum wing width; mid tibial spur nearly as long as basal mid tarsal segment. Gaster about as long as thorax; genitalia with digiti long with apical hooks, nearly half length of aedeagus, aedeagus about one-half length of mid tibia or twice length of mid tibial spur.

COMMENTS. This genus belongs to the Charitopidini (Tetracneminae). The general body structure suggests a close affinity with *Charitopus* from which it can be separated in the female by the colour and structure of the antenna and incomplete notaular lines (complete in *Charitopus*); the male can be separated by the unbranched antenna and incomplete notaular lines.

***Eotopus beneficus* (Shafee) comb. n.**

(Figs 150, 325–327)

It is quite clear from Shafee's (1981) original description that his material had been in alcohol and therefore parts of his description need augmenting or correcting as follows.

♀. Length: 0.92–1.59 mm.

Colour. Head dark metallic green with some coppery or purple reflections, particularly on frontovertex, antenna from yellowish to testaceous yellow; pronotum and mesoscutum varying from almost entirely orange with a darker longitudinal metallic green stripe to almost entirely metallic green with orange area at extreme sides outside notaular lines, axillae from entirely orange through metallic green to deep metallic purple, scutellum metallic green to metallic green mixed purple and blue; sides of thorax from almost entirely orange to almost entirely dark brown (especially the mesopleurum); propodeum medially dark brown, laterally dark brown mixed to a lesser or greater extent with orange; wings hyaline but very lightly stained yellow; legs, including coxae, pale orange-yellow; gaster mostly orange with tergites laterally strongly metallic purple.

Head. As in original description except that posterior ocellus is separated from occipital margin by at least slightly more than and usually nearly twice its own diameter. Relative measurements of head: length 60, width (facial view) 70, width (side view) 38, minimum frontovertex width 24, malar space 12, eye length 48, eye width 33, POL 12, OOL 4, scape length 40, scape width 7, antenna as in Fig. 325. There is a little variation in the relative width of the frontovertex, but it is usually about one-third maximum head width; Shafee states that the scape is 'slightly more than four times as long as wide', but in no specimens has it been found to be as broad, usually about five and one-half times as long as broad; there is also some variation in the relative proportions of the flagellar segments, the distal segments sometimes at least one-half longer than broad whereas usually they are only about one-quarter longer than broad; there is also some variation in the size of the ocelli so that POL and OOL may be a little different from that given above.

Thorax. Forewing very nearly three times as long as broad, not two and one-half times as given by Shafee. There is some variation in the relative length of the postmarginal vein which is normally about as long as the stigmal, but in some specimens it is clearly a little shorter, both types occurring occasionally in a single specimen. Relative measurements: forewing length 165, width 56, hindwing length 119. Forewing base as in Fig. 150.

Gaster. Relative lengths: last tergite 45, ovipositor 52, gonostyli approx. 7, [mid tibia 86]. Genitalia as in Fig. 326.

♂. Differs from female as follows. *Colour.* Very much as female except that lower parts of face often coloured orange, gaster more or less entirely orange but with apical one-half to one-third dorsally brown; ocelli forming a distinctly obtuse angle; for antenna see Shafee (1981: fig. j); relative measurements: head length 40, head width (facial view) 14, minimum width of frontovertex 28, malar space 12, eye length 23, eye width 17, POL 12, OOL 6, scape length 19. Genitalia as in Fig. 327; relative lengths: aedeagus 34, mid tibial spur 16. There is some variation in the relative width of the frontovertex so that in some specimens it is a little broader than length of scape, also POL may be a little less than twice OOL depending on the relative size of the ocelli and width of frontovertex.

DISTRIBUTION. India.

BIOLOGY. Reared from *Icerya pilosa* Green (Homoptera, Margarodidae) on *Saccharum officinarum* Linnaeus (Shafee, 1981).

MATERIAL EXAMINED

India: 1 ♀, determined as *Ericydnus beneficus* Shafee and probably a paratype but no data or determination labels; 1 ♀, Uttar Pradesh, Aligarh, on grass, 23.ii.1979 (*M. Hayat & M. Verma*); 1 ♀, Uttar Pradesh, Aligarh, 20.viii.1979 (*M. Verma*); 1 ♀, Tamil Nadu, Shembaganur, x.1979 (*J. S. Noyes*); 2 ♀, 7 ♂, Kerala, Periyar Animal Sanctuary, 5–15.x.1979 (*J. S. Noyes*); 3 ♀, 7 ♂, Tamil Nadu, 3 km E. of Manjaler Dam, 5–18.x.1979 (*J. S. Noyes*), 1 ♂, Tamil Nadu, Anamalai Animal Sanctuary, 21.x.1979 (*J. S. Noyes*); 9 ♀, 6 ♂, Tamil Nadu, Mudumalai Animal Sanctuary, 23–24.x.1979 (*J. S. Noyes*); 26 ♀, 8 ♂, Karnataka, Mudigere, 26.x-4.xi.1979 (*J. S. Noyes*); 13 ♀, 6 ♂, Karnataka, 25 km W. of Mudigere, 28.x-3.xi.1979 (*J. S. Noyes*); 1 ♂, Karnataka, Bannerghatta N. P., 5.xi.1979 (*Z. Bouček & J. S. Noyes*); 1 ♂, Kerala, Calicut University Area, xi.1979 (*Z. Bouček*); 1 ♂, Hyderabad, Patancheru, ICRISAT, vii-ix.1980, Malaise trap (Bernays & Woodhead) (BM, HC, USNM, UCR, ZI, PPRI).

EPANUSIA Girault

(Key couplet: 107)

Epanusia Girault, 1915a: 154. Type-species: *Epanusia bifasciatus* Girault, by original designation.

DISTRIBUTION AND SPECIES. Australia only; two species: *beenleighi* Girault (1923e: 5) and *bifasciata* Girault (1915a: 154).

BIOLOGY. Unknown.

COMMENTS. The two included species are very close but are distinct. They can be separated on the shape of the scape, but more easily by the extent of the infuscate areas of the forewing; the forewing of *beenleighi* is infuscate to its base, whilst that of *bifasciata* is largely hyaline in the basal cell.

The genus belongs to the same group as *Cryptanusia* (see comments under *Cryptanusia*).

EPIBLATTICIDA Girault

(Key couplets: 197, 367, 506)

Epiblatticida Girault, 1915a: 117. Type-species: *Epiblatticida lambi* Girault, by original designation.
Neasteropaeus Girault, 1915a: 109. Type-species: *Neasteropaeus caudatus* Girault, by original designation.

Syn. n.

Blatticidella Girault, x.1923c: 144. Type-species: *Blatticidella aereitibiae* Girault, by monotypy.
 [Homonym of *Blatticidella* Gahan & Fagan, iv. 1923.] **Syn. n.**

Microencyrtus Girault, 1923c: 147. Type-species: *Microencyrtus minutissimus* Girault, by monotypy.
Syn. n.

Magellanana Girault, 1939b: 324. [Replacement name for *Blatticidella* Girault.] **Syn. n.**

DISTRIBUTION AND SPECIES. Australia, New Caledonia and New Zealand only; five described species: *aereitibiae* (Girault, 1923c: 144) (**comb. n.** from *Blatticidella*) (Australia), *argentipes* (Girault, 1925b: 99) (**comb. n.** from *Epitetracnemus*) (Australia), *caudatus* (Girault, 1915a: 109) (**comb. n.** from *Neasteropaeus*) (Australia), *lambi* Girault (1915a: 117) (Australia) and *minutissimus* (Girault, 1923c: 147) (**comb. n.** from *Microencyrtus*), also undetermined material from New Caledonia and New Zealand (BMNH, BPBM, DSIR).

BIOLOGY. Hyperparasites of Psyllidae (Homoptera) via other Encyrtidae.

COMMENTS. Closely related to *Coccidoctonus* (see comments, p. 254).

EPIDINOCARSIS Girault

(Key couplets: 174, 221. Fig. 94)

Epidinocarsis Girault, 1913b: 83. Type-species: *Epidinocarsis tricolor* Girault, by original designation.
Apoanagyrs Compere, 1947a: 18. Type-species: *Apoanagyrs californicus* Compere, by original designation. **Syn. n.**

DISTRIBUTION AND SPECIES. Fifteen species, New World, Palaearctic, Oriental, Australasian and Pacific; seven species from review area: *anamalaianus* (Mani & Kaul in Mani *et al.*, 1974: 63) (**comb. n.** from *Anagyrs*) (India), *auraticutum* Girault (1915a: 144) (Australia), *californicus* (Compere, 1947a: 18) (**comb. n.** from *Apoanagyrs*) (Hawaiian Is.), *cuneinota* Girault (1915a: 144) (Australia), *marquesanus* (Timberlake, 1941: 220) (**comb. n.** from *Anagyrs*) (Marquesas Is.), *rotundiceps* (Girault, 1932a: 3) (**comb. n.** from *Dinocarsis*) (Australia) and *tricolor* Girault (1913b: 83) (Australia).

REFERENCE. Partial revision: Kerrich (1982: 407–416).

BIOLOGY. Parasites of Pseudococcidae (Homoptera).

COMMENTS. Two of the above species may be misplaced here, but we have placed them in this genus in an attempt to achieve a degree of consistency within the key. One is *marquesanus* which shows an affinity with *punctifrons* (Timberlake) which we place in *Doliphoceras* only because of a difference in the sculpture of the scutellum (a character used to separate these two genera). The other is *rotundiceps* which could also be placed in *Anagyrs* because the sculpture of the head and mesoscutum is somewhat intermediate between the two genera (see comments under *Anagyrs*).

We deliberated for some time before synonymising these two genera, but since we were unable to find any real difference between *tricolor* and *californicus* (the respective type-species) except colour we decided to do so here. Although *Apoanagyrs* is a fairly well-known name we do not think that it is necessary to submit an application to the International Commission on Zoological Nomenclature to ask for suppression of *Epidinocarsis* in favour of *Apoanagyrs*. Our reasons for this are that we do not think the use of *Epidinocarsis* will lead to undue confusion in the literature and also that a detailed study of this group of genera on a world-wide basis may result in the synonymy of *Epidinocarsis* (and thus *Apoanagyrs*) and *Doliphoceras* with *Anagyrs* (see also comments under *Anagyrs*).

As a result of this new generic synonymy we also propose the following transfers of extra-limital species from *Apoanagyrs* to *Epidinocarsis*: *bermudensis* Kerrich, *diversicornis* Howard, *elgeri* Kerrich, *gaudens* Kerrich, *lopezi* De Santis, *malenotus* De Santis, *montivagus* De Santis and *trinidadensis* Kerrich (all **comb. n.**).

EPISTENOTERYS Girault

(Key couplets: 364, 390)

Epistenoterys Girault, 1915a: 149. Type-species: *Epistenoterys marmoratipes* Girault, by monotypy.
Gounodia Girault, 1940: 149. Type-species: *Gounodia mellea* Girault, by monotypy. **Syn. n.**

DISTRIBUTION AND SPECIES. Two species, Australia only: *marmoratipes* Girault (1915a: 149) and *mellea* (Girault, 1940: 149) (**comb. n.** fom *Gounodia*), also undetermined material from Australia containing at least one further species (BMNH).

BIOLOGY. Parasites of Pseudococcidae (Homoptera).

COMMENTS. The above two species appear to differ only in coloration and minor morphological characters which we regard as specific and not generic differences. Perhaps the most significant difference between the two is the length of the malar space relative to the eye. In *mellea* it is only a little shorter than the eye whereas in *marmoratipes* it is a little less than two-thirds the length of an eye.

The genus is related to *Aphycus*, *Cirrhencyrtus* Timberlake and possibly *Pseudaphycus* (tribe Aphycini, subtribe Aphycina).

EPITETRACNEMUS Girault

(Key couplets: 140, 488. Fig. 72)

Epitetracnemus Girault, 1915a: 164. Type-species: *Epitetracnemus sexguttatipennis* Girault, by original designation.

Anabrolepis Timberlake, 1920: 431. Type-species: *Anabrolepis extranea* Timberlake, by original designation. **Syn. n.**

DISTRIBUTION AND SPECIES. Five species, cosmopolitan; three from review area: *extraneus* (Timberlake, 1920: 434) (**comb. n.** from *Anabrolepis*) (Hawaiian Is.), *sexguttatipennis* (Girault, 1915a: 164) (Australia) and *zetterstedti* (Westwood; Mercet, 1921: 678) (**comb. n.** from *Encyrtus*) (New Zealand), also at least one further species amongst material from India, S. China, New Caledonia and Australia (BMNH, BPBM).

REFERENCE. Review of most species: Tachikawa (1955).

BIOLOGY. Parasites of Diaspididae (Homoptera).

COMMENTS. The following extra-limital species are also transferred from *Anabrolepis* to *Epitetracnemus*: *japonicus* Ishii and *lindingaspidis* Tachikawa (both **comb. n.**).

This genus belongs to the tribe Habrolepidini, subtribe Habrolepidina (Encyrtinae) and is closely related to *Adelencyrtus* (see comments under *Adelencyrtus*).

EPITETRALOPHIDEA Girault

(Key couplets: 194, 519. Fig. 115)

Epitralophidea Girault, 1915a: 176. Type-species: *Epitralophidea bicinctipes* Girault, by original designation.

Ectromomyiella Girault, 1915a: 160. Type-species: *Ectromomyiella articulus* Girault, by original designation. **Syn. n.**

DISTRIBUTION AND SPECIES. Three species, all Australian: *articulus* (Girault, 1915a: 160) (**comb. n.** from *Ectromomyiella*), *bicinctipes* Girault (1915a: 176) (= *Epitralophidea bicinc-*

tipis emersoni Girault, 1923c: 142 **syn. n.**) and *magnithorax* (Girault, 1923c: 146) (**comb. n.** from *Ooencyrtus*).

BIOLOGY. Unknown.

COMMENTS. Girault unfortunately described *articulus* from a single male. However, amongst material on the same slide as the type of *Casca nigra* Girault, *Ablerus speciosus* Girault, *Perissopterus inexplicabilis* Girault and *Ooencyrtus magnithorax* Girault, are some males which appear to be identical to the holotype of *articulus*. It would seem reasonable to assume that all this material may have been reared from the same host and put on one slide (under two separate coverslips). Therefore it is likely that the encyrtid males under one coverslip are the same species as the encyrtid females, *Ooencyrtus magnithorax*, under the other. Since *magnithorax* is here considered to be congeneric with *bicinctipes* we have no hesitation in regarding *Ectromomyiella* as a synonym of *Epitetrалophidea*.

Epitetrалophidea appears to be very close to *Coccidencyrtus* (tribe Habrolepidini) from which it can be separated by the uninterrupted linea calva and the two-segmented funicle in the male. The latter suggests that it may also be closely related to *Adelencyrtus* from which it differs in having the mandible with a single tooth and a broad truncation, that of *Adelencyrtus* having four teeth or occasionally two teeth and a truncation.

ERENCYRTUS Mahdihassan

(Key couplets: 178, 394. Fig. 103)

Erencyrtus Mahdihassan, 1923: 71. Type-species: *Erencyrtus dewitzi* Mahdihassan, by monotypy.

DISTRIBUTION AND SPECIES. Four species, Afrotropical, Oriental, Australasian; two from review area: *dewitzi* Mahdihassan; Ferriere (1935: 396) (India, Pakistan) and *keatsi* (Girault, 1939a: 21) (**comb. n.** from *Mesastymachus*) (Australia).

REFERENCES. Annecke & Mynhardt (1970a), Prinsloo & Mynhardt (1982: 38–41).

BIOLOGY. Parasites of lac insects (Homoptera, Keriidae).

COMMENTS. The genus is easily recognisable in that the antenna of the male has a very short two-segmented funicle and the clava is extremely long (more than twice as long as the scape and pedicel together) and unsegmented.

Placed in the tribe Microteriyini, subtribe Microteriyina by Trjapitzin (1973b).

ERICYDNUS Walker

(Key couplet: 211)

Ericydnus Walker, 1837: 363. Type-species: *Ericydnus paludatus* Walker, by designation of Westwood (1840: 71).

Grandoriella Domenichini, 1951: 171. Type-species: *Grandoriella lamasi* Domenichini, by original designation.

DISTRIBUTION AND SPECIES. Thirteen species, cosmopolitan; none known from review area, but undescribed species examined from India, New Guinea and Australia (BMNH, BPBM).

REFERENCE. World revision: Kerrich (1967: 167–180).

BIOLOGY. Parasites of Pseudococcidae (Homoptera).

COMMENTS. Two other species previously placed in *Ericydnus*, i.e. *chrysos* (Walker, 1839: 34) and *megalarus* (Walker, 1838b: 477), do not belong in the Encyrtidae (see Kerrich, 1967: 179).

The species from the Australasian and Oriental regions differ from the known species of *Ericydnus* in that the antennal toruli are placed relatively higher on the head with their ventral margins being nearly level with the ventral margins of the eyes. They also have a sharper occipital margin and the relative length of the gaster is less. We do not consider that these

differences warrant separate generic status, but if future workers regard these species as belonging to a separate genus they should perhaps consider using *Grandoriella* as a generic name for this group.

The genus is placed in the tribe Ericydini (Tetracneminae).

***ETHORIS* gen. n.**

(Key couplet: 315. Figs 156, 187, 328–331)

Type-species: *Ethoris dahmsi* sp. n. Gender: feminine.

♀. *Head*. In frontal view about as long as broad, in profile less than twice as long as broad and more or less gradually and evenly rounded anteriorly, but more strongly so at top of antennal scrobes. Eyes with posterior margin almost straight but very slightly concave, about one-third longer than broad, clothed in fairly dense translucent setae each a little longer than the diameter of a facet; eye reaching occipital margin which is more or less sharp but not strongly so. Malar space about half as long as eye with sulcus present. Frontoververtex about half head width or a little less; ocelli nearly forming an equilateral triangle, the posterior ones about equidistant from occipital and eye margins or a little nearer the latter, separated from eyes by slightly less than to much less than their own diameters. Antennal scrobes shallow, separated dorsally by interantennal prominence which is confluent with frontoververtex, fairly sharp at this point and extends almost all the way to mouth margin, scrobes very short, only reaching about one-quarter way from toruli to anterior ocellus; antennal torulus separated from mouth margin by nearly twice its length and from other torulus by about its own length, its lower margin only a little below the lower margins of eyes; clypeus with margin straight or very slightly produced medially. Antennal scape subcylindrical, about five or six times as long as broad and clearly longer than minimum width of frontoververtex; pedicel conical, about one-third length of scape and subequal in length to any of the funicle segments all of which are clearly longer than broad and are cylindrical; clava about two-fifths as long as and not wider than funicle, three-segmented, apically rounded and almost pointed with sutures parallel. Frontoververtex with shallow, raised, reticulate sculpture, becoming more irregular and elongate at top of scrobes and between scrobes and eyes and on genae; setae on frontoververtex sparse, about as long as diameter of an ocellus. Mandible with three acute teeth; maxillary palpus relatively long, four-segmented, apical segment nearly one and one-half times as long as mandible and a little shorter than its apical seta; labial palpus three-segmented.

Thorax. In side view moderately deep, mesoscutum slightly convex, scutellum clearly more convex than mesoscutum; metapleurum and propodeum very narrowly in contact with hind coxa. In dorsal view pronotum with hind margin moderately concave; visible part of mesoscutum about twice as broad as long, notaular lines absent, hind margin more or less straight, only slightly convex; axillae meeting; scutellum about as long as mesoscutum, about as broad as long and apically rounded; propodeum medially about one-fifth length of scutellum. Mesoscutum with shallow, raised, squamiform-reticulate sculpture, axillae similar but a little finer and deeper; scutellum with conspicuously deeper, reticulate sculpture, regular medially but more elongate towards sides, extreme apex and sides smooth; mesopleurum almost smooth, but with some irregular, very shallow sculpture; propodeum medially smooth; dorsum of thorax with fairly numerous, moderately long, pale brown, inconspicuous setae. Forewing hyaline, about two and one-half times as long as broad; lineae calva not interrupted or closed; filum spinosum present; submarginal vein with an apical hyaline break; costal cell about 10 or 11 times as long as broad; marginal vein about five or six times as long as broad, slightly shorter than to one and one-half times as long as stigmal and clearly shorter than postmarginal vein; postmarginal and stigmal veins forming an unusually acute angle. Hindwing a little less than two-thirds as long as forewing, about four and one-half times as long as broad, with marginal fringe about one-quarter as long as maximum width of wing. Mid tibial spur about as long as basal mid tarsal segment.

Gaster. About as long as thorax; cercal plates in basal half; hypopygium with apex about two-thirds along gaster; last tergite about two-thirds as long as mid tibia; ovipositor very slightly exerted, a little shorter than mid tibia; gonostyli free, about one-quarter as long as ovipositor.

♂. Unknown.

COMMENTS. We are unable to place the genus according to Trjapitzin's (1973b) classification of the Encyrtinae. It may be close to either *Ageniaspis* (Copidosomatini, Ageniaspidina) or less probably to *Rhytidothorax*. The relatively high position of the antennal toruli and the very long terminal segments of the maxillary palpus should separate it from either of these genera; the

conformation of the antenna, the sculpture and coloration from *Ageniaspis* and the less prominent hypopygium and short propodeum from *Rhytidothorax*.

The type-species is named in honour of Mr E. C. Dahms (QM).

***Ethoris dahmsi* sp. n.**

(Figs 156, 187, 328–331)

♀. Length: 1.05–1.14 mm (holotype, 1.05 mm).

Colour. Head dark metallic green with slight coppery sheen between anterior ocellus and antennal scrobes; scape yellowish, pedicel, funicle and basal segment of clava dark brown, apical two segments of clava white; face of pronotum medially, anterior margin of mesoscutum medially dark brown; scutellum except sides dark metallic green, remainder of thorax, including legs, pale orange with metanotum and dorsum of propodeum darker brownish orange; gaster dorsally brown, ventrally pale orange.

Head. Relative measurements (holotype): head length 55, head width (facial view) 58, head width (side view) 33, minimum frontovertex width 24, malar space 19, eye length 37, eye width 28, POL 9, OOL 4, diameter of anterior ocellus 5, scape length 33, scape width 6, proportions of antennal segments as in Fig. 328, head in facial view as in Fig. 331, mandible as in Fig. 329.

Thorax. Relative measurements (holotype): forewing length 155, width 61; hindwing length 102, width 22.5; base of forewing as in Fig. 156, venation as in Fig. 187. The angle between the stigmal and postmarginal veins is a little variable and may be slightly greater than in Fig. 187.

Gaster. Relative lengths (paratype): last tergite 63, ovipositor 85, gonostyli 23, [mid tibia 94]. Genitalia as in Fig. 330.

♂. Unknown.

DISTRIBUTION. Sulawesi, India.

BIOLOGY. Unknown.

MATERIAL EXAMINED

Holotype ♀, **Sulawesi:** Tengah, nr Morowali, ii.1980, Ranu River area, lowland rain forest, Malaise trap (*M. J. D. Brendell*) (BMNH).

Paratypes. **Sulawesi:** 1 ♀, same data as holotype, iii.1980. **India:** 1 ♀, Hyderabad, Patancheru, ICRISAT, vii–ix.1980, Malaise trap (*Bernays & Woodhead*) (BMNH).

COMMENTS. Also found in Zimbabwe and Cameroun (BMNH) and may be the same as *dahmsi* from which it differs slightly in coloration, relative size and position of ocelli and relative proportion of stigmal vein of forewing to marginal vein.

***EUCOMOMORPHELLA* Girault**

(Key couplet: 459)

Eucomomorphella Girault, 1923c: 100. Type-species: *Eucomomorphella emersoni* Girault, by monotypy.

DISTRIBUTION AND SPECIES. Australia only, one species: *emersoni* Girault (1923c: 100).

BIOLOGY. Unknown.

COMMENTS. The genus is probably related to *Prionomastix* (tribe Prionomasticini, subtribe Prionomasticina) and differs from this and related genera by having three teeth in the mandible and the hypopygium not reaching half way along gaster (see also comments under *Anagyrodes* and *Encyrtus*).

***EUGAHANIA* Mercet**

(Key couplet: 143. Fig. 78)

Eugahania Mercet, 1926: 43. Type-species: *Bothriothorax fumipennis* Ratzeburg, by original designation.

DISTRIBUTION AND SPECIES. Four species, Palaearctic, Oriental and Australasian; two species from review area: *ishiharai* Tachikawa (1956: 164) (India) and *laticapus* (Ishii, 1925: 27)

(India), also undetermined specimens from India, Vietnam, Taiwan, Indonesia, Irian Jaya and Papua New Guinea (BMNH, BPBM, RMNH).

REFERENCE. Key to species: Hayat & Khanna (1977).

BIOLOGY. Parasites of nymphs of Cicadellidae (Homoptera).

COMMENTS. Placed in the tribe Eugahaniini (Encyrtinae) (see also comments under *Anagyrodes* and *Encyrtus*).

***EURYRHOPALUS* Howard**

(Key couplet: 501)

Euryrhopalus Howard, 1898b: 237. Type-species: *Euryrhopalus schwarzi* Howard, by monotypy.
Synaspidia Timberlake, 1924: 397. Type-species: *Synaspidia pretiosa* Timberlake, by original designation.

DISTRIBUTION AND SPECIES. Nine species, New World; one species from review area: *propinquus* Kerrich (1967: 240) (Hawaiian Is.).

REFERENCE. World revision: Kerrich (1967: 235–246).

BIOLOGY. Parasites of Pseudococcidae (Homoptera).

COMMENTS. The genus belongs to the tribe Aenasiini (see comments under *Aenasius*). A key separating *Euryrhopalus* from related genera is provided by Kerrich (1967: 188–190).

***EUSEMION* Dahlbom**

(Key couplet: 112. Fig. 51)

Eusemion Dahlbom, 1857: 293. Type-species: *Encyrtus corniger* Walker, by subsequent monotypy, Thomson, 1876: 154.

DISTRIBUTION AND SPECIES. Two species, Palearctic; one of these from New Zealand: *cornigerum* (Walker; Annecke, 1967: 103).

BIOLOGY. Parasites of Coccidae (Homoptera).

COMMENTS. Placed in the tribe Cerapterocerini (Encyrtinae). A key to separate *Eusemion* from related genera is provided by Annecke (1967: 100–101).

***EXORISTOBIA* Ashmead**

(Key couplets: 201, 334, 449, 531. Fig. 238)

Exoristobia Ashmead, 1904a: 15. Type-species: *Exoristobia philippinensis* Ashmead, by monotypy.
Parasyrphophagus Girault, 1915a: 105. Type-species: *Parasyrphophagus funeralis* Girault, by original designation. **Syn. n.**

Parageniapsis Masi, 1917b: 154. Type-species: *Parageniapsis macrocerus* Masi by monotypy. **Syn. n.**
Mirsyrphophagus Girault, 1923a: 49. Type-species: *Mirsyrphophagus columbi* Girault, by monotypy. **Syn. n.**

DISTRIBUTION AND SPECIES. Six species, Afrotropical, Oriental and Australasian; three from review area: *columbi* (Girault, 1923a: 49) (**comb. n.** from *Mirsyrphophagus*) (Australia), *funeralis* (Girault, 1915a: 105) (**comb. n.** from *Parasyrphophagus*) (Papua New Guinea, Australia) and *philippinensis* Ashmead (1904a: 15) (Pakistan to Papua New Guinea), also undetermined material from Thailand to New Hebrides (BMNH, BPBM).

REFERENCE. Subba Rao (1970).

BIOLOGY. Parasites of Syrphidae, Tachinidae and Phoridae (Diptera).

COMMENTS. The single extant female of *Parageniapsis macrocerus* Masi in the collection of the BMNH is here designated LECTOTYPE. It belongs to the genus *Exoristobia* (**comb. n.**). The

female syntype in the ZMCU belongs to *Cerchysiella*, whilst the single male syntype (BMNH) is very probably the male of *macrocerus*.

One species (BMNH) which has been reared from Phoridae associated with pitcher plants (see Beaver, 1979) is very distinct, having the dorsum of the thorax extremely hairy and the prothoracic spiracle very enlarged and prominent, being clearly visible at low magnification in dry-mounted material.

The two genera described by Girault differ only slightly from each other and from *philippinensis* in the shape of the mandible, but since this can vary even in a single specimen it is not considered to be of generic value. The genus may belong in the Microteriyini but we are unable to place it with any degree of certainty according to Trjapitzin's (1973*b*) classification of the Encyrtinae. Trjapitzin & Gordh (1978*b*) place it in the tribe Cheiloneurini, subtribe Epiencyrtina which must be incorrect.

FULGORIDICIDA Perkins

(Key couplets: 339, 431, 437)

Fulgoridicida Perkins, 1906: 250. Type-species: *Fulgoridicida dichroma* Perkins, by monotypy.

DISTRIBUTION AND SPECIES. Five species, all Australian: *cervantesi* Girault (1923: 47), *dichroma* Perkins (1906: 250), *minuta* Girault (1915: 148), *nigricorpus* Girault (1915*a*: 148) and *simpliciscapus* Girault (1915*a*: 148), also at least one further species from Papua New Guinea and Australia (BMNH, BPBM).

BIOLOGY. Parasites of eggs of Eurybrachidae (Homoptera).

COMMENTS. Girault (1915*a*: 147) transferred *Anagyrus saintpierrei* Girault to *Fulgoridicida*, but this is probably not correct. It is more likely that *saintpierrei* is an aberrant species of *Coelopencyrtus*.

The genus is quite close to *Ooencyrtus* (Microteriyini, subtribe Ooencyrtina) but differs mainly in having fairly deep punctate-reticulate sculpture on the head and mesoscutum and a bidentate mandible (that of *Ooencyrtus* has one or two teeth and a truncation or, rarely, three teeth).

GAHANIELLA Timberlake

(Key couplets: 190, 435. Figs 113, 227, 324)

Gahaniella Timberlake, 1926: 23. Type-species: *Gahaniella californica* Timberlake, by original designation.

DISTRIBUTION AND SPECIES. Three species, New World; one species from review area: *saissetiae* Timberlake (1926: 27) (Hawaiian Is.).

REFERENCE. Kerrich (1953: 800–802).

BIOLOGY. Hyperparasites of Coccidae and Pseudococcidae (Homoptera) via other Encyrtidae, possibly also primary parasites of Coccidae.

COMMENTS. Placed in the tribe Microteriyini by Trjapitzin & Gordh (1978*b*). The genus can be recognised by the relatively high placement of the antennal toruli (Fig. 113) and the subequal pedicel and funicle segments (Fig. 227).

GENTAKOLA gen. n.

(Key couplet: 155. Figs 84, 85, 332–339)

Type-species: *Comperiella trifasciata* Saraswat. Gender: feminine.

♀. *Head*. Prognathous, occipital foramen situated in dorsal one-third of occiput; head in dorsal view a little longer than broad and subrectangular with occipital margin distinctly concave, in side view also subrec-

tangular, about one-half longer than broad and with genae dorso-anteriorly produced above and to side of the antennal toruli (Fig. 332). Eye with posterior margin clearly convex, about one-half longer than broad, with fairly sparse inconspicuous setae each very slightly longer than the diameter of a facet and about half as long as those on frontovertex, eye not quite reaching occipital margin which is sharp. Malar space about half length of eye and with sulcus absent. Frontovertex slightly more than one-third head width; ocelli forming a very slightly acute angle, posterior ocellus separated from occipital and eye margins by slightly less than its own diameter. Antennal scrobes not deep but bounded laterally by the dorso-anterior projection of the genae and dorsally by the sharp angle resulting from the face being sharply inflexed at this point, thus the scrobes more or less semi-circular and reaching about three-eighths way from antennal toruli to anterior ocellus; antennal torulus separated from mouth margin by not more than half its length and from other torulus by about twice its length, its dorsal margin well below ventral level of eyes; clypeal margin very shallowly excised between toruli. Antennal scape much longer than minimum width of frontovertex, clearly broadened and flattened, subrectangular about twice as long as broad, pedicel conical, about one-third length of scape or funicle, the latter a little shorter than the scape, all funicle segments transverse, at least about twice as broad as long and broadly oval in cross section, slightly broadening distally so that sixth segment is clearly as broad as clava which is two-segmented, with apex rounded and a little shorter than funicle; longitudinal sensillae on all flagellar segments except the first two. Frontovertex entirely smooth and shiny, genal process with shallow irregular rugose sculpture, frontovertex with a few inconspicuous setae, each a little longer than diameter of an ocellus. Mandible narrow with three apical teeth, the middle one slightly the longest, maxillary palpus four-segmented, labial palpus three-segmented (a little obscure in the only slide preparation available and may be two-segmented).

Thorax. In side view very slightly dorso-ventrally flattened with mesoscutum and scutellum quite flat, metapleurum laterally obscure and, together with propodeum, quite broadly in contact with hind coxa. In dorsal view pronotum quite long, slightly longer than half mesoscutum and with posterior margin slightly concave; visible part of mesoscutum slightly less than twice as broad as long, without notaular lines and with its posterior margin slightly produced backwards medially; axillae meeting; scutellum about as long as broad, apically rounded with a very narrow apical flange which projects slightly over propodeum medially and slightly longer than mesoscutum; propodeum medially about one-fifth length of scutellum. Pronotum with shallow, raised, transverse rugose to squamiform-reticulate sculpture; mesoscutum with very shallow, transverse, rugose sculpture, scutellum completely smooth and polished, propodeum medially with shallow, irregular, raised reticulate sculpture; mesopleurum smooth; dorsum of thorax with sparse, short, recumbent dark setae. Forewing slightly bent upwards at about middle as in *Comperiella*, with three longitudinal fuscous streaks, about three times as long as broad; linea calva not clearly defined and not interrupted, there being at most only one or two setae on surface of wing proximal of it (Fig. 334); filum spinosum present and directed towards junction of marginal and submarginal veins; submarginal vein with an apical hyaline break and with parastigma a little swollen; marginal vein about two and one-half to three times as long as broad, about one-half longer than postmarginal and subequal to stigmal vein, apex of venation not reaching half way along wing; costal cell about 11 or 12 times as long as broad, with a single line of setae dorsally in apical one-third. Hindwing also slightly infusate, about two-thirds as long as forewing, about four times as long as broad and with marginal fringe about one-quarter of wing width. Mid tibial spur very slightly longer than basal mid tarsal segment.

Gaster. Very slightly shorter than thorax; cercal plates in anterior one-half; hypopygium more or less reaching apex of gaster; paratergites absent; last tergite about as long as mid tibia; gonostyli free, about one-quarter length of ovipositor which is nearly as long as mid tibia.

♂. Differs from female as follows. Occipital foramen not quite in dorsal one-third of occiput, head about as long as broad in facial view, with only very slight dorso-anterior projections of genae; eye about one-quarter longer than broad, with setae not longer than diameter of a facet and clearly not reaching occipital margin which is sharp; malar space about half as long as eye; frontovertex a little more than head width; ocelli forming a right angle, antennal torulus separated from mouth margin by nearly its own length, from other torulus by slightly more than twice its own length; antennal scape distinctly shorter than width of frontovertex, subrectangular, stout, about twice as long as broad; pedicel a little less than half length of scape, subquadrate, longer than any funicle segment, all funicle segments transverse, the sixth being the longest and broadest and almost quadrate, clava entire, about half length of funicle; longest setae on flagellum about twice as long as diameter of corresponding segment; frontovertex almost entirely smooth but with some very shallow rugose-reticulate sculpture immediately above the scrobes. Mesoscutum with very shallow squamiform-reticulate sculpture. Forewing not bent at middle, hyaline and about two and one-half times as long as broad; apex of venation reaching about two-fifths along wing. Mid tibial spur distinctly longer than basal mid tarsal segment. Gaster a little shorter than thorax; genitalia with digiti

about one-fifth length of aedeagus which is slightly longer than half mid tibia or two and one-half times mid tibial spur.

COMMENTS. The genus superficially resembles *Comperiella*, but the structure of the gaster, the relatively long propodeum, the clearly tridentate mandible, the forewing venation and the filum spinosum being directed towards the junction of the submarginal and marginal veins suggest an affinity with *Cerchysiella* and *Zaommoencyrtus* which are placed in the tribe Bothriothoracini, subtribe Coenocercina. It can be separated from other members of the subtribe by the shape of the head, two-segmented clava and infuscate forewing, the latter being bent upwards at the middle.

***Gentakola trifasciata* (Saraswat) comb. n.**

(Figs 84, 85, 332–339)

♀. The female can easily be recognised from Saraswat's (*in Saraswat & Mukerjee, 1975: 51*) original description. There seems to be some variation in colour; in one dry-mounted specimen the head is largely green or greenish blue with anterior genal protuberance more or less deep purple and the clypeus and interantennal prominence quite strongly orange; the scutellum is more strongly blue than in Saraswat's description. Also the mandible is quite clearly tridentate (not quadridentate) and the clava is two-segmented (not three-segmented) (Fig. 85). These discrepancies may have arisen as a result of Saraswat having based his description on uncleared slide-mounted material, the clava of the dry-mounted specimen examined having the appearance of being three-segmented. Genitalia as in Fig. 333, hypopygium as in Fig. 335.

♂. Length: 0.71 mm. Body generally dark purplish brown except scutellum which is slightly metallic green; leg coloration more or less as for female. For other characters see Figs 336–339.

DISTRIBUTION. India.

BIOLOGY. Unknown.

MATERIAL EXAMINED

India: 1 ♀, 1 ♂, Tamil Nadu, Coimbatore, 25.ix–1.x.1979 (*J. S. Noyes*); 1 ♀, Karnataka, Bannerghatta N. P., 5.xi.1979 (*Z. Bouček & J. S. Noyes*); 1 ♂, Delhi, IARI area, x.1979 (*Z. Bouček*) (BMNH).

GYRANUSOIDEA Compere

(Key couplets: 149, 172, 268. Fig. 93)

Gyranusoidea Compere, 1947a: 17. Type-species: *Gyranusa citrina* Compere, by original designation.

DISTRIBUTION AND SPECIES. Fifteen species, cosmopolitan except for Palaearctic; 7 species from review area: *advena* Beardsley (1969: 303) (Hawaiian Is.), *albiclavata* (Ashmead, 1905b: 404) (**comb. n.** from *Aphycus*) (Philippines), *ceroplastis* (Agarwal, 1965: 73) (India), *flava* Shafee, Alam & Agarwal (1975: 21) (India), *indica* Shafee, Alam & Agarwal (1975: 22) (India), *mirzai* (Agarwal, 1965: 46) (**comb. n.** from *Anagyrus*) (India) and *phenacocci* (Beardsley, 1969: 299) (Hawaiian Is.), also undetermined material from Taiwan, Philippines, Australia and New Britain (BMNH, BPBM, UCR, HC).

REFERENCE. Key to some species: Shafee *et al.* (1975: 21).

BIOLOGY. Parasites of Pseudococcidae (Homoptera).

COMMENTS. The genus belongs to the tribe Anagyrini, subtribe Anagyrina (Tetracneminae) and is extremely difficult to separate from *Anagyrus* on one hand and *Leptomastidea* on the other. We have separated it from *Anagyrus* solely by the postmarginal vein of the forewing being at least one-quarter longer than the stigmal whereas in *Anagyrus* it is not or hardly longer. This is an extremely doubtful character for separating the two genera, but we have found it more convenient and easier to define than the shape of the scape or sculpture of the head and thorax. From *Leptomastidea* we have separated it basically on the head and thorax having fine punctate sculpture of velvety or granulate appearance and the forewing being more or less hyaline,

whereas species placed in *Leptomastidea* have smoother, shallower sculpture and the forewing often with two or more fuscous fasciae. Use of the above characters has resulted in the undesirable transfer of some species from other genera to *Gyranoidea*, but we have found this necessary to achieve a degree of consistency within the key. We feel certain that an in-depth study of this group of genera on a world basis will result in the eventual synonymy of most genera of the Anagryna. This is beyond the scope of the present work and therefore we have tried to retain most of the genera as valid even though it has meant separating some of them on weak characters such as those above (see also comments under *Anagryrus*).

HABROLEPIS Förster

(Key couplet: 97. Fig. 48)

Habrolepis Förster, 1856: 34. Type-species: *Encyrtus nubilipennis* Walker, by original designation.
Gymnoneura Risbec, 1951: 157. Type-species: *Gymnoneura bambeyi* Risbec, by monotypy.

DISTRIBUTION AND SPECIES. Twenty-one species, cosmopolitan; three species from review area: *dalmani* (Westwood; Annecke & Mynhardt, 1970: 134) (New Zealand), *neocaledonensis* Fabres (1974: 56) (New Caledonia) and *rouxi* Compere (1936a: 495) (Hawaiian Is.), also undetermined material, containing at least one further species, from Australia and Samoa (ANIC, CNC).

REFERENCE. Annecke & Mynhardt (1970b: 128–146).

BIOLOGY. Parasites of Diaspididae and Asterolecaniidae (Homoptera).

COMMENTS. Placed in the tribe Habrolepidini, subtribe Habrolepidina (Encyrtinae).

HALIGRA gen. n.

(Key couplet: 532. Figs 253, 254, 340–345)

Type-species: *Haligra concolor* sp. n. Gender: feminine.

♀. **Head.** In facial view about as long as broad and in profile about three-fifths as broad as long and gradually curved dorsally, below top of antennal scrobes almost straight. Eye with posterior margin straight, about one-third longer than broad, with numerous conspicuous, translucent setae, each about as long as the diameter of a facet, eye almost touching occipital margin which is sharp. Malar space slightly longer than half eye length, with sulcus present. Frontovortex about one-third head width; ocelli forming a slightly acute angle, the posterior ocellus about equidistant from eye and occipital margins. Antennal scrobes shallow, meeting dorsally and almost semicircular, reaching about half way from toruli to anterior ocellus; antennal torulus separated from mouth margin by a little less than its own length and from other torulus by slightly more than its own length, its upper margin about half its length below level of lowest eye margin, clypeal margin very shallowly excised between toruli. Antennal scape clearly longer than minimum width of frontovortex, fairly slender, about five times as long as broad; pedicel conical, about one-third as long as scape and clearly much longer than any of the funicle segments which are all strongly transverse, the first the smallest and sixth the largest; clava three-segmented with a short oblique truncation apically, the outer suture converging slightly with the inner, clava about as long as and much broader than the funicle; longitudinal sensillae on fifth and sixth funicle segments and clava; longest setae on flagellum about as long as or a little longer than corresponding segment. Head almost totally smooth and shiny but with some extremely shallow, raised irregular sculpture on the frontovortex, immediately above scrobes and below this more or less completely smooth and polished except on genae posterior to malar suture and on temples which have very shallow, raised, reticulate sculpture; setae on frontovortex dark and conspicuous, each at least about twice as long as diameter of an ocellus, those on lower parts of face and interantennal prominence about the same. Mandible with three acute teeth, the middle one clearly the longest; maxillary palpus four-segmented, labial palpus two-segmented.

Thorax. In side view robust with mesoscutum and scutellum conspicuously convex, the metapleurum and propodeum not quite meeting the hind coxa, although mesopleurum clearly separated from basal segment of gaster. In dorsal view pronotum almost completely hidden, its posterior margin very concave; visible part of mesoscutum about twice as broad as long, with notaular lines absent and its posterior margin almost straight; axillae separated by about half the length of an axilla in dorsal view; scutellum a little

broader than long, apically rounded; propodeum medially about one-sixth length of scutellum. Mesoscutum with longitudinally elongate, raised, reticulate sculpture of moderate depth, the cells more or less arranged in lines which slightly converge posteriorly; scutellum with finer, striate-reticulate sculpture of about the same depth or a little deeper than mesoscutum; propodeum with irregular raised sculpture medially and some sculpture along its anterior margin nearly reaching spiracles; mesopleurum almost completely smooth but with some extremely shallow irregular sculpture. Forewing more or less completely hyaline but very faintly suffused brownish, between two and one-half to three times as long as broad; linea calva not interrupted but partially closed by two lines of setae; flum spinosum present; submarginal vein with an apical hyaline break, parastigma not conspicuously swollen; costal cell over 20 times as long as broad, with a single line of setae dorsally in its distal one-third; marginal vein about three times as long as broad, nearly twice as long as stigmal which is about as long as postmarginal. Hindwing very slightly suffused brownish as in forewing, about two-thirds length of forewing, about five times as long as broad with marginal fringe about half as long as maximum wing width. Mid tibial spur about as long as or a little shorter than basal mid tarsal segment.

Gaster. A little longer than thorax with apex of hypopygium reaching to about two-thirds along gaster; ovipositor not or hardly exerted; cercal plates situated about half way along gaster; paratergites absent; last tergite about three-quarters as long as mid tibia; ovipositor about as long as mid tibia, gonostyli free, about one-fifth as long as ovipositor.

♂. Unknown.

COMMENTS. We are unable to place this genus according to Trjapitzin's (1973*b*) classification of the Encyrtinae. However, it does bear some resemblance to *Forcipesticis* Burks and the two may be related, although the present genus lacks the pits on the scutellum which are so characteristic of *Forcipesticis*.

Haligra concolor sp. n.

(Figs 253, 254, 340–345)

♀. Length: approx. 0.78–0.87 mm (holotype, 0.87 mm).

Colour. Body generally very dark brown or black; head quite shiny, antenna dark brown; mesoscutum slightly shiny, scutellum matt except the almost vertical apical surface which is completely smooth and shiny, legs dark brown with apices of fore tibia, mid tibia, hind femur and tibia and fore and hind tarsi testaceous, apical three-quarters of mid tibia and tarsus testaceous-yellow; gaster with some slight brassy reflections.

Head. Relative measurements (holotype): head length 52, head width (facial view) 53, head width (side view) 30, minimum width of frontovertex 17.5, malar space 20, eye length 34, eye width 26, POL 9, OOL 3, scape length 26, scape width 5.5, proportions of antenna as in Fig. 253, mandible as in Fig. 341.

Thorax. Sculpture of mesoscutum as in Fig. 340, of scutellum as in Fig. 254. Relative measurements (holotype): forewing length 130, width 51, other proportions of forewing as in Figs 342, 344; hindwing length 92, width 18. The paratype has the forewing nearly three times as long as broad and the postmarginal vein on right wing a little longer than stigmal, whilst on left wing it is a little shorter.

Gaster. Relative lengths (paratype): last tergite 45, ovipositor 64, [mid tibia 63]; genitalia as in Fig. 345, hypopygium as in Fig. 343.

♂. Unknown.

DISTRIBUTION. India.

BIOLOGY. Unknown.

MATERIAL EXAMINED

Holotype ♀, **India**: Uttar Pradesh, Aligarh, 11.ii.1979, on grass (*M. Hayat*) (BMNH).

Paratype. **India**: 1 ♀, Uttar Pradesh, Aligarh, 11.ii.1978, on grass (*M. Hayat*) (HC).

HAMBLETONIA Compere

(Key couplet: 122. Figs 62–64)

Hambletonia Compere, 1936a: 172. Type-species: *Hambletonia pseudococcina* Compere, by original designation.

DISTRIBUTION AND SPECIES. One species, New World; also Hawaiian Is. and Taiwan: *pseudococcina* Compere (1936a: 173).

BIOLOGY. Parasites of Pseudococcidae (Homoptera).

COMMENTS. Placed in the tribe Chrysoplatycerini, subtribe Chrysoplatycerina (Trjapitzin & Gordh, 1978b: 648), although it might possibly be more closely related to *Taftia* (subtribe Taftiina). It can be easily recognised by the conspicuous long setae arising from the dorsal surface of the pedicel.

HAMUSENCYRTUS Subba Rao & Hayat

(Key couplets: 84, 170. Figs 38, 39, 92, 346)

Hamusencyrtus Subba Rao & Hayat, 1979: 2. Type-species: *Scelioencyrtus mymaricoides* Compere, Subba Rao & Kaur, by original designation.

Neoxanthoencyrtus Avasthi & Shafee, 1980: 535. Type-species: *Scelioencyrtus mymaricoides* Compere, Subba Rao & Kaur, by original designation.

DISTRIBUTION AND SPECIES. Two species, possibly synonymous, India and Pakistan only: *indicus* (Shafee, Alam & Agarwal, 1975: 33) (India) and *mymaricoides* (Compere, Subba Rao & Kaur, 1960: 46) (India, Pakistan), also further undetermined material, possibly including undescribed species, from India (BMNH, HC).

BIOLOGY. Parasites of Pseudococcidae (Homoptera).

COMMENTS. The genus can be placed in the tribe Anagyrini, subtribe Rhopina (Tetracneminae) and is possibly closest to *Asitus*. It can be distinguished from this genus by having a two-segmented clava (solid in *Asitus*), distinct axillae (fused with scutellum in *Asitus*) and forewing venation not quite reaching anterior margin of wing (reaches anterior margin in *Asitus*).

HELEGONATOPUS Perkins

(Key couplets: 283, 337)

Helegonatopus Perkins, 1906: 257. Type-species: *Helegonatopus pseudophanes* Perkins, by monotypy.

Chalcerinys Perkins, 1906: 258. Type-species: *Chalcerinys eximia* Perkins, by monotypy. **Syn. n.**

Schedioides Mercet, 1919a: 96. Type-species: *Schedioides formosus* Mercet, by monotypy.

Euchalcerinys Timberlake, 1922a: 161. Type-species: *Euchalcerinys apicicornis* Timberlake, by original designation. **Syn. n.**

Hazmburkia Hoffer, 1954: 172. Type-species: *Hazmburkia dimorpha* Hoffer, by original designation.

Masencyrtus Hoffer, 1960: 98. Type-species: *Masencyrtus concupiens* Hoffer, by original designation.

Paludencyrtus Hoffer, 1965: 16. Type-species: *Paludencyrtus nikolskajae* Hoffer, by original designation.

DISTRIBUTION AND SPECIES. Fifteen species, cosmopolitan; five species from review area: *apicicornis* (Timberlake, 1922a: 165) (**comb. n.** from *Euchalcerinys*) (Hawaiian Is.), *eximia* (Perkins, 1906: 259) (**comb. n.** from *Chalcerinys*) (Hawaiian Is.), *ponomarenkoi* Trjapitzin (1964a: 143) (India), *pseudophanes* Perkins (1906: 258) (Hawaiian Is.) and *pulchricornis* Hayat & Verma (1978: 355) (India), also undetermined material from Java (BPBM).

REFERENCE. Szelenyi (1972b: 348–352).

BIOLOGY. Hyperparasites of Auchenorrhyncha (Homoptera) via Dryinidae (Hymenoptera).

COMMENTS. We have examined one female and one male of what are probably syntypes of *Chalcerinys eximia* Perkins (BMNH); they are close to, if not the same as *pulchricornis* and therefore we propose the synonymy of *Chalcerinys* and *Helegonatopus*. We favour use of *Helegonatopus* as the valid generic name since it is the better known of the two, although *Chalcerinys* is the type-genus of the tribe Chalcerinyini.

We have also examined the holotype of *Euchalcerinys apicicornis* Timberlake (BPBM) and are confident that it also belongs in the genus *Helegonatopus*.

The genus belongs in the tribe Chalcerinyini (Encyrtinae).

HEMILEUCOCERUS Hoffer

(Key couplet: 294)

Hemileucocerus Hoffer, 1976: 101. Type-species: *Hemileucocerus insignis* Hoffer, by original designation.

DISTRIBUTION AND SPECIES. Only one described species known, Europe; at least two further species from India, Laos and Borneo (BMNH, HC, BPBM).

BIOLOGY. Unknown.

COMMENTS. We have not seen any material authoritatively determined as *Hemileucocerus insignis* Hoffer, but material examined from the Canary Is. (BMNH) agrees well with Hoffer's generic description. This material is congeneric with that from India, Laos and Borneo.

Hemileucocerus belongs in the same group as *Aseirba* and *Austroencyrtus* and can be separated from these genera by the characters given in the key (see also comments under *Aseirba*).

HENGATA gen. n.

(Key couplet: 307. Figs 154, 347–354)

Type-species: *Hengata spinosa* sp. n. Gender: feminine.

♀. *Head*. In facial view about as long as broad, in profile about twice as long as broad, anteriorly more or less evenly and gradually curved, the lower part of the interantennal prominence quite clearly visible. Eye with posterior margin a little concave, about one-half longer than broad, covered with numerous, fairly inconspicuous translucent setae, each nearly as long as the diameter of a facet, eye very slightly overreaching occipital margin which is sharp. Malar space about half length of eye, with sulcus present. Frontoververtex about two-fifths head width; ocelli forming a right angle, the posterior ones separated from eye or occipital margin by a little less than their own diameters. Antennal scrobes shallow and semicircular, meeting dorsally and extending slightly more than half way from toruli to anterior ocellus; antennal torulus separated from mouth margin and other torulus by about one and a half times its own length, its dorsal margin a little above the ventral margin of eyes, clypeal margin shallowly excised below toruli. Antennal scape longer than minimum width of frontoververtex, almost cylindrical, about five times as long as broad; pedicel conical about one-third length of scape and slightly longer than any funicle segment, all of which are subequal and a little longer than broad; clava three-segmented, the sutures subparallel, its apex more or less pointed; longitudinal sensillae on all flagellar segments; longest setae about as long as diameter of corresponding segment. Frontoververtex almost smooth, but with extremely shallow, raised, regular, reticulate sculpture, much more elongate and irregular between antennal scrobes and eyes and on genae and temples; frontoververtex and interantennal prominence with a few moderately long, dark setae; genae and clypeal margin with translucent setae. Mandible with two teeth and a truncation; maxillary palpus four-segmented, labial palpus three-segmented.

Thorax. In side view robust with mesoscutum and scutellum fairly convex, the mesopleurum posteriorly enlarged and touching basal segment of gaster, thus clearly separating the propodeum and metapleurum from the hind coxa. In dorsal view pronotum with posterior margin broadly concave; visible part of mesoscutum nearly twice as broad as long, broadly concave, notaular lines absent, a very shallow median longitudinal ridge in posterior half, posterior margin clearly convex and projecting above axillae medially; axillae separated by about two-thirds width of an axilla in dorsal view; scutellum convex, about as broad as long and about as long as mesoscutum, its apex rounded; propodeum medially not more than about one-tenth length of scutellum, laterally with only two or three setae to the outside of the spiracle. Mesoscutum with very shallow, raised, squamiform-reticulate sculpture, becoming more shallow posteriorly, scutellum anteriorly, and axillae with extremely shallow, raised, reticulate sculpture, posterior half or so of scutellum completely smooth; propodeum almost completely smooth; dorsum of thorax clothed in sparse, moderately long, conspicuous, dark setae. Forewing hyaline, about two and one-half times as long as broad; linea calva not interrupted and open; filum spinosum present; submarginal vein with an apical hyaline break, with parastigma not conspicuously swollen; costal cell nearly 15 times as long as broad, with a single line of setae dorsally in its apical one-third or so; marginal vein about twice as long as broad, subequal to stigmal and postmarginal veins. Hindwing about two-thirds length of forewing, about four and one-half times as long as broad, with marginal fringe about one-quarter as long as maximum wing width. Mid tibial spur a little shorter than basal mid tarsal segment.

Gaster. Slightly longer than thorax; cercal plates at about midway along its length; hypopygium with its apex reaching to nearly two-thirds along gaster; paratergites absent; last tergite about half as long as mid tibia; ovipositor hardly exerted, a little shorter than mid tibia, gonostyli free, about one-quarter length of ovipositor.

♂. Similar to female except body generally darker, antenna and genitalia. Differs as follows. Head clearly broader than long; malar space nearly two-thirds as long as eye; frontovertex nearly half as wide as head; posterior ocelli a little further from eye margin than from occipital margin; antennal scape about as long as width of frontovertex with a very large thorn-like process arising from its ventral margin, from the apex of which is a strong, apically hooked bristle, scape thus only about twice as long as greatest width, pedicel conical, subquadrate, about as long as first funicle segment but clearly shorter than those following which are all longer than broad and subequal, clava entire; longitudinal sensillae on all flagellar segments except the first two, longest setae on funicle very nearly twice as long as diameter of segments. Forewing with costal cell about 12 times as long as broad, with marginal, stigmal and postmarginal veins proportionately a little shorter than in female. Genitalia with aedeagus about half as long as mid tibia, digiti each armed with one apical hook, about one-sixth length of aedeagus.

COMMENTS. The expanded mesopleurum, structure of the mandible, and mesoscutum dorsally separating the axillae indicate that this genus is related to *Ooencyrtus* and *Fulgoridicida* (Microteryni, Ooencyrtina), also *Amira* (Amirini). It can be separated from these and all other genera by the shallow but distinct median longitudinal ridge or carina on the mesoscutum. The peculiar thorn-like process on the scape of the male is also another distinguished character.

Hengata spinosa sp. n.

(Figs 154, 347–354)

♀. Length: 0.71–0.95 mm (holotype, 0.95 mm).

Colour. Body generally pale brownish yellow; frontovertex a little darker, with greenish reflections, clypeus dark brown; scape yellow, pedicel and flagellum brown, clava white; face of pronotum, mesoscutum anteriorly, scutellum in posterior half, mesopleurum posteriorly, propodeum and apical half of gaster, dark brown, the posterior half of scutellum with a slight greenish or purplish sheen; legs yellow, mid coxa brown; base of gaster and proximal half of venter yellowish. In some specimens the darker brown areas are less intense or less extensive and occasionally the propodeum is yellowish; occasionally the base of the hind coxa is dark brown.

Head. Relative measurements (holotype): head length 56, head width (facial view) 57, head width (side view) 26, minimum width of frontovertex 21, malar space 20, eye length 37, eye width 25, POL 9, OOL 3, scape length 33, scape width 6, other proportions of antenna as in Fig. 348; mandible as in Fig. 347.

Thorax. Relative measurements (holotype): forewing length 147, width 58, hindwing length 98, width 22. Base of forewing as in Fig. 154, venation as in Fig. 349.

Gaster. Relative lengths (paratype): last tergite 43, ovipositor 75, [mid tibia 87]; genitalia as in Fig. 351, hypopygium as in Fig. 350.

♂. Length: 0.71–0.94 mm. Similar to female except following. Body completely dark brown, legs and gaster as in female. Antenna as in Fig. 352; genitalia as in Figs 353, 354. Relative measurements (paratype 1): head width 74, minimum frontovertex width 33, scape length 31, forewing length 172, forewing width 73, hindwing length 114, hindwing width 28, mid tibia length 70, aedeagus length 32; relative measurements (paratype 2): scape length 20, scape width (to apex of thorn-like process) 10, POL 9.5, OOL 3. (Paratype 1 on a slide; paratype 2 dry-mounted on a card.)

DISTRIBUTION. Indonesia (Sulawesi).

BIOLOGY. Unknown.

MATERIAL EXAMINED

Holotype ♀, **Indonesia**: Sulawesi, Tengah, Ranu River area, nr Morowali, ii.1980, lowland rain forest, Malaise trap (*M. J. D. Brendell*) (BMNH).

Paratypes. **Indonesia**: 4 ♀, 6 ♂, same data as holotype; 4 ♀, 4 ♂, same data as holotype but iii.1980; 10 ♀, 11 ♂, same data as holotype but 27.i.–20.iv.1980 (*M. J. D. Brendell*) (BMNH, USNM, UCR, ZI, PPRI, HC).

HESPERENCYRTUS Annecke

(Key couplet: 136)

Hesperencyrtus Annecke, 1971a: 86. Type-species: *Paraphaenodiscus lycoeniphila* Risbec, by original designation.

DISTRIBUTION AND SPECIES. One species known, Afrotropical; also reported from India: *lycoeniphila* (Risbec, 1951: 147).

BIOLOGY. Parasites of the pupae of Lycaenidae (Lepidoptera).

COMMENTS. The material referred to by Hayat & Subba Rao (1981: 113) should be in the collections of the BMNH. We have been unable to locate it and therefore it must be assumed that this material was originally misidentified or has been lost.

The genus belongs in the tribe Microteriyini and probably the subtribe Microteriyina (Encyrtinae).

HETEROCCIDOXENUS Ishii

(Key couplets: 280, 419. Fig. 172)

Heterococcidoxenus Ishii, 1940: 103. Type-species: *Heterococcidoxenus javensis* Ishii, by original designation.

Microsphenus Kerrich, 1963: 365. Type-species: *Bothriothorax schlehtendali* Mayr, by original designation.

DISTRIBUTION AND SPECIES. Two species, Palaearctic and Australasian; one from review area: *javensis* Ishii (1940: 103) (Java).

BIOLOGY. Parasites of Scolytidae (Coleoptera).

COMMENTS. Placed in the tribe Bothriothoracini, subtribe Bothriothoracina (Encyrtinae).

HEXENCYRTUS Girault

(Key couplets: 222, 290)

Hexencyrtus Girault, 1915a: 105. Type-species: *Hexencyrtus albiclava* Girault, by original designation.

Calliencyrtus De Santis, 1960: 61. Type-species: *Calliencyrtus bucculentus* De Santis, by original designation. **Syn. n.**

DISTRIBUTION AND SPECIES. Two species, Neotropical, Oriental and Australasian; one from review area: *albiclava* Girault (1915a: 105) (= *Hexencyrtus fumosipennis* Girault, 1915a: 106 **syn. n.**), also further undetermined material from Vietnam and Papua New Guinea (BPBM).

BIOLOGY. Unknown.

COMMENTS. We have compared a specimen of *Hexencyrtus albiclava* (compared with holotype) with a specimen determined as *Calliencyrtus bucculentus* by De Santis. They are very close and certainly belong in the same genus.

The genus is difficult to place according to Trjapitzin's (1973b) classification of the Encyrtinae, but it almost certainly belongs to the same generic group as *Parastenoterys* and *Rhythidothorax* (see also comments under *Parastenoterys*).

HOLANUSOMYIA Girault

(Key couplet: 158. Figs 83, 355, 356)

Holanusomyia Girault, 1915c: 165. Type-species: *Holanusomyia pulchripennis* Girault, by original designation.

DISTRIBUTION AND SPECIES. One species, Philippines only: *pulchripennis* Girault (1915c: 165).

BIOLOGY. Unknown.

COMMENTS. The genus is related to *Yasumatsuiola* which is placed in the tribe Dinocarsiini (Trjapitzin, 1977: 155). It is easily recognised by the abnormally long stigmal vein of the forewing. We have seen other material from Taiwan (UCR, BPBM) which could possibly be placed in this genus but refrain from doing so until a more detailed study of the group, to which this genus belongs, can be undertaken.

HOLCOTHORAX Mayr

(Key couplet: 67)

Holcothorax Mayr, 1876: 691. Type-species: *Encyrtus testaceipes* Ratzeburg, by designation of Gahan & Fagan (1923: 72).

DISTRIBUTION AND SPECIES. Two species, European; neither from review area, but one undescribed species from India (BMNH).

BIOLOGY. Polyembryonic parasites of the larvae of Gracillariidae and Nepticulidae (Lepidoptera).

COMMENTS. The species from India is intermediate between *Holcothorax* and *Paraleurocerus* Girault, having sculpture of the head and thorax similar to the latter, but with a five-segmented funicle. It is probable that these two genera and *Ageniaspis* will eventually be considered synonymous.

Holcothorax is placed in the tribe Copidosomatini, subtribe Ageniaspidina (see comments under *Ageniaspis*).

HOMALOPODA Howard

(Key couplet: 54)

Homalopoda Howard in Riley, Ashmead & Howard, 1894: 90. Type-species: *Homalopoda cristata* Howard, by monotypy.

DISTRIBUTION AND SPECIES. One described species from the Neotropics, Sri Lanka and the Hawaiian Is.: *cristata* Howard; Noyes (1979: 157), also undetermined material from Java (BMNH).

BIOLOGY. Parasites of Diaspididae (Homoptera).

COMMENTS. We have not examined any of the material determined as *cristata* from either Sri Lanka or the Hawaiian Is. and therefore cannot confirm its identity.

The genus belongs to the tribe Habrolepidini, subtribe Habrolepidina.

HOMALOTYLUS Mayr

(Key couplets: 34, 239, 354, 388. Figs 6, 146, 198)

Homalotylus Mayr, 1876: 752. Type-species: *Encyrtus flaminus* Dalman, by designation of Ashmead (1900b: 377).

Nobrimus Thomson, 1876: 116. Type-species: *Encyrtus flaminus* Dalman, by designation of Timberlake (1919a: 134).

Mendozaniella Brèthes, 1913: 97. Type-species: *Mendozaniella mirabilis* Brèthes, by monotypy.

Hemaenasioidea Girault, 1916c: 307. Type-species: *Hemaenasioidea oculata* Girault, by monotypy.

Anisotylus Timberlake, 1919a: 170. Type-species: *Homalotylus similis* Ashmead, by original designation.

Syn. n.

Lepidaphycus Blanchard, 1936: 13. Type-species: *Lepidaphycus bosqi* Blanchard, by monotypy.

Neoaenasioidea Agarwal, 1966: 71. Type-species: *Neoaenasioidea indica* Agarwal, by original designation.

DISTRIBUTION AND SPECIES. Twenty-eight species, cosmopolitan; 12 species from review area: *albiclavatus* (Agarwal, 1970: 27) (India), *ferrierei* Hayat, Alam & Agarwal (1975: 67) (India),

flaminius (Dalman, 1820: 340) (India, S. China, Java, Australia), *indicus* (Agarwal, 1966: 73) (India), *mexicanus* Timberlake (1919a: 155) (India), *microgaster* Girault (1917g: 134) (Australia), *mundus* Gahan (1920: 343) (Philippines), *nigrinus* (Agarwal, 1970: 27) (India), *nipaecocci* (Subba Rao, 1967: 1) (India), *oculatus* (Girault, 1916b: 308) (Philippines), *orci* Girault (1917a: 3) (Java), *terminalis* (Say; Timberlake, 1919a: 148) (India), also much undetermined material from throughout the region (BMNH, BPBM, GC, HC).

REFERENCES. Revision: Timberlake (1919a: 133–170); review of Indian species: Hayat *et al.* (1975: 64–69).

BIOLOGY. Parasites of coccinellid larvae (Coleoptera, Coccinellidae).

COMMENTS. We do not believe that the retention of *Anisotylus* as a valid genus is realistic; at most, the characters used to separate it from *Homalotylus* (bidentate mandible and venation) can be considered as valid only on a specific or perhaps species-group level but certainly not at generic level. This proposal is further supported by the fact that, where known, all species of *Anisotylus* are parasitic on coccinellid larvae.

Timberlake (1919a: 141) synonymised both *orci* and *microgaster* with *flaminius*. Mr P. B. Jensen (pers. comm.) has studied the type of *flaminius* and informed us that the species may have been misinterpreted. For this reason we are maintaining these species as distinct until the matter can be resolved.

The genus is placed in the tribe Homalotylini, subtribe Homalotyliina (see also comments under *Aphycus*).

HUNTERELLUS Howard

(Key couplets: 81, 152, 214)

Hunterellus Howard, 1908: 240. Type-species: *Hunterellus hookeri* Howard, by monotypy.

Australzaomma Girault, 1925b: 97. Type-species: *Australzaomma brunnea* Girault, by monotypy. **Syn. n.**

DISTRIBUTION AND SPECIES. Five species, cosmopolitan; four from review area: *brunneus* (Girault, 1925b: 96) (**comb. n.** from *Australzaomma*) (Australia), *hookeri* Howard (1908: 241) (India, Malaysia, Hawaiian Is.), *mysorensis* (Mani, 1941: 29) (**comb. n.** from *Ixodiphagus*) (India) and *sagarensis* Geevarghese (1977: 49) (India).

BIOLOGY. Parasites of nymphs of Ixodidae (Acarina).

COMMENTS. We have not examined the type of *Ixodiphagus mysorensis* but it would seem reasonable to assume from the description and distribution that it is a species of *Hunterellus*.

The genus belongs to the tribe Ixodiphagini (Encyrtinae).

HYPERGONATOPUS Timberlake

(Key couplets: 90, 474, 485. Figs 42, 43, 226)

Hypergonatopus Timberlake, 1922a: 142. Type-species: *Echthrogonatopus hawaiiensis* Perkins, by original designation.

Aulonops Timberlake, 1922a: 158. Type-species: *Aulonops bifasciata* Timberlake, by original designation. **Syn. n.**

DISTRIBUTION AND SPECIES. Eight species, all from Hawaiian Is.: *bifasciatus* (Timberlake, 1922a: 159) (**comb. n.** from *Aulonops*), *brunneipes* Timberlake (1922a: 154), *flavipes* Timberlake (1922a: 155), *hawaiiensis* (Perkins, 1912: 17), *hemipterus* Timberlake (1922a: 157), *molokaiensis* (Ashmead, 1901: 322), *oahuensis* Timberlake (1922a: 153) and *vulcanus* Timberlake (1922a: 152).

REFERENCE. Revision: Timberlake (1922a: 142–161).

BIOLOGY. Hyperparasites of Auchenorrhyncha (Homoptera) via Dryinidae (Hymenoptera).

COMMENTS. We have examined the holotype of *Aulonops bifasciata* (BPBM) and conclude that it must be regarded as belonging to the genus *Hypergonatopus*.

The genus is placed in the tribe Chalcerinyini by Trjapitzin (1973*b*) but we think it would probably be better placed in the Cheiloneurini. It is possible that future study will show that the Chalcerinyini could be considered as a subtribe within the Cheiloneurini.

INDAPHYCUS Hayat

(Key couplet: 62. Figs 24, 357)

Indaphycus Hayat, 1981*b*: 20. Type-species: *Indaphycus planus* Hayat, by original designation.

DISTRIBUTION AND SPECIES. One species, India only: *planus* Hayat (1981*b*: 21).

BIOLOGY. Unknown.

COMMENTS. It is possible that *Pseudectroma bryanti* Girault will run to *Indaphycus* in the key since this species may have a solid clava. It will probably be possible to determine its correct generic placement only when fresh material is available for study.

The genus is apparently close to *Acerophagus* and *Pseudectroma* (tribe Aphycini, subtribe Aphycina) from which it can be separated using the characters given in the key, notably by the elongate pronotum.

ISODROMOIDES Girault

(Key couplets: 453, 472)

Isodromoides Girault, 1914*a*: 30. Type-species: *Isodromoides triangularis* Girault, by original designation.

Neocopidosomyia Girault, 1915*a*: 95. Type-species: *Neocopidosomyia viridiscutellum* Girault, by original designation. **Syn. n.**

DISTRIBUTION AND SPECIES. One species, Australia only: *triangularis* Girault (1914*a*: 30) (= *Neocopidosomyia viridiscutellum* Girault, 1915*a*: 95 **syn. n.**), also at least one further species from Australia (BMNH).

BIOLOGY. Hyperparasites of Epipyropidae (Lepidoptera) parasitic on Fulgoridae (Homoptera).

COMMENTS. The genus appears to be related to *Ooencyrtus* (tribe Microteryni, subtribe Oencyrtina) from which it can be separated by having a solid clava (that of *Ooencyrtus* is three-segmented).

ISODROMUS Howard

(Key couplet: 389. Figs 200, 201)

Isodromus Howard, 1887: 488. Type-species: *Isodromus iceryae* Howard, by monotypy.

Parataneostigma Girault, 1915*d*: 275. Type-species: *Parataneostigma nigriaxillae* Girault, by monotypy.

DISTRIBUTION AND SPECIES. Fourteen species, cosmopolitan; one species from review area: *axillaris* Timberlake (1919*b*: 185) (China, Hawaiian Is.), also undetermined material from Pakistan, Philippines and Australia (BMNH, BPBM).

REFERENCE. Revision: Timberlake (1919*b*: 176–190).

BIOLOGY. Parasites of larvae of Chrysopidae and Hemerobiidae (Neuroptera).

COMMENTS. Placed in the tribe Homalotylini, subtribe Homalotyliina (see also comments under *Aphycus*).

KAKAOURRA Girault

(Key couplet: 319)

Kakaourra Girault, 1922*a*: 44. Type-species: *Kakaourra fera* Girault, by monotypy.

DISTRIBUTION AND SPECIES. Australia only, two described species: *angeliconini* (Girault, 1924a: 6) (**comb. n.** from *Echthrocacca*) and *fera* Girault (1922a: 44), also possibly two further species from Australia and New Zealand (BMNH, DSIR).

BIOLOGY. Unknown.

COMMENTS. The single extant syntype (probably the holotype) of *Kakaoburra fera* is in very poor condition (QM); fragments of the head and one forewing on a slide and legs on a card are all that remain. However, the wing venation, arrangement of the setae in the basal cell and relatively short scape are very characteristic and we believe that we have interpreted the genus correctly by assigning *angeliconini* to it.

Kakaoburra, as we understand it, is probably very close to *Mayridia* (subtribe Mayridiina) which Trjapitzin (1973b) has incorrectly placed in the tribe Miraini (see comments under *Ectroma*, *Mira* and *Mayridia*).

KATAKA gen. n.

(Key couplets: 223, 319. Figs 132, 358–367)

Type-species: *Kataka mudigerensis* sp. n. Gender: feminine.

♀. *Head*. In facial view (Fig. 358) about one-fifth broader than long, in profile slightly more than one and one-half times as long as broad and anteriorly more or less gradually and evenly curved although slightly flatter from top of scrobes to lowest level of toruli. Eye with posterior margin straight, about one-half longer than broad, much shorter than minimum width of frontovertex; naked and separated from occipital margin by at least about the diameter of an ocellus; occipital margin rounded. Malar space about three-quarters as long as eye, with sulcus present although not well marked. Frontovertex slightly less than two-thirds head width; ocelli forming an obtuse angle of about 120–130° the posterior ones about equidistant from eye and occipital margin. Antennal scrobes very shallow, semicircular, meeting dorsally, reaching slightly less than half way from antennal torulus to anterior ocellus; antennal torulus separated from mouth margin by nearly twice its own length and from other torulus by about one-quarter more than its own length, its lowest margin a little below lowest eye margin; clypeal margin shallowly but broadly excised below toruli. Antennal scape about two-thirds as long as minimum width of frontovertex and about four times as long as broad; pedicel conical, about half length of scape and a little longer than any funicle segment, all of which are longer than broad, the first the longest and sixth shortest; clava three-segmented, apically rounded with sutures parallel and about one-third length of funicle; longitudinal sensillae on all flagellar segments, longest setae slightly shorter than diameter of corresponding segment. Sculpture on frontovertex shallow, raised reticulate, fairly regular and almost hexagonal, on cheeks and between toruli and eyes more elongate and tending towards squamiform-reticulate; setae on frontovertex and genae fairly numerous, dark and short, each not longer than about the diameter of an ocellus. Mandible with two teeth and a truncation or obscurely tridentate with upper tooth broadly rounded; maxillary palpus four-segmented, labial palpus three-segmented.

Thorax. In side view moderately robust with mesoscutum and scutellum flat, the hind margin of the mesopleurum clearly separating the hind coxa from the metapleurum and propodeum and more or less in contact with basal gastral segment (Fig. 361). In dorsal view with posterior margin of pronotum moderately concave; visible part of mesoscutum about one-half broader than long, with notaular lines absent, its posterior margin slightly concave medially; axillae meeting, scutellum a little broader than long and a little longer than mesoscutum with apex acute; propodeum medially about one-seventh as long as scutellum and medially with some shallow, irregular, reticulate sculpture. Dorsum of thorax with fairly regular, shallow, raised, almost hexagonal sculpture, covered in numerous, conspicuous dark brown setae. Forewing more or less hyaline but almost imperceptibly infused pale brown, about three times as long as broad; linea calva not interrupted but closed near posterior margin of wing by two lines of setae; filum spinosum present; submarginal vein without an apical hyaline break, parastigma not thickened; costal cell about 10 times as long as broad, with one or two lines of setae dorsally along its entire length; marginal vein about four times as long as broad, a little longer than stigmal and at least twice as long as postmarginal. Hindwing about two-thirds as long as forewing and about five times as long as broad, marginal fringe about one-third as long as wing width. Mid tibial spur a little longer than basal mid tarsal segment.

Gaster. A little shorter than thorax; cercal plates in basal half; hypopygium with apex reaching to about four-fifths along gaster, clothed in very long setae apically; paratergites absent; last tergite a little shorter

than two-thirds mid tibia; ovipositor slightly shorter than mid tibia, gonostyli free, about one-sixth as long as ovipositor.

♂. Very similar to female but differs as follows. Antennal scrobes very shallow, almost non-existent; antennal toruli a little higher on head, their lowest margins about level with lowest eye margins; antennal scape less than two-thirds as long as minimum width of frontovertex, about three and one-half times as long as broad, pedicel about as long as each funicle segment all of which are clearly longer than broad; clava entire, about twice as long as a funicle segment; longest setae on flagellum about as long as diameter of segments. Forewing with linea calva open or closed by a single line of setae on dorsal surface. Genitalia with aedeagus about half as long as mid tibia, digiti each with apical hook and about one-seventh as long as aedeagus.

COMMENTS. The relatively high placement of the antennal toruli, rounded occipital margin, wing venation and flattened thoracic dorsum indicate that this genus may be related to *Mayridia* (see comments under *Mayridia*). It can be separated from this genus in having the setae on the dorsal surface of the forewing extending to the base, the mandible having the third (upper) tooth more or less truncate, relatively smaller eyes and posteriorly enlarged mesopleurum (in profile, the hind coxa is in contact with the propodeum in *Mayridia*).

***Kataka mudigerensis* sp. n.**

(Figs 132, 358–367)

♀. Length: 0.98–1.22 mm (holotype, 1.22 mm).

Colour. Head, dorsum of thorax and gaster black with some slight green, brassy and purple reflections on head, purple reflections on mesoscutum, axillae and basal two-thirds or so of scutellum; apical one-third or so of scutellum green, gaster basally with a metallic green sheen, strongly coppery-purple over remainder; antennal scape, mesopleurum and legs yellowish orange, antennal pedicel and flagellum brown.

Head. Facial view as in Fig. 358. Relative measurements (holotype): head length 58, head width (facial view) 69, head width (side view) 35, minimum frontovertex width 40, malar space 25, eye length 33, eye width 22, POL 22, OOL 8, scape length 30, scape width 8, other proportions of antenna as in Fig. 359, mandible as in Fig. 360.

Thorax. Relative measurements (holotype): forewing length 170, width 61, proportions of veins as in Figs 132, 362; hindwing length 119, width 24. Basal cell of forewing with setae to base and nearly twice as dense as in distal half of wing; propodeum with 10–12 very long translucent setae immediately outside each spiracle, each seta about twice as long as diameter of spiracle.

Gaster. Relative lengths (paratype): last tergite 23, ovipositor 31.5, gonostyli 4.5, [mid tibia 38]; genitalia as in Fig. 364, hypopygium as in Fig. 363.

♂. Length: 0.89–0.92 mm. Generally similar to female except for antenna (Fig. 367) and genitalia (Figs 365, 366). Relative measurements (paratype): scape length 33, scape width 10, minimum width of frontovertex 48, length of mid tibia 89, length of aedeagus 40.

DISTRIBUTION. India.

BIOLOGY. Unknown.

MATERIAL EXAMINED

Holotype ♀, **India:** Karnataka, Mudigere, 26.x–4.xi.1979 (*J. S. Noyes*) (BMNH).

Paratypes. **India:** 4 ♀, 3 ♂, same data as holotype (BMNH).

LAKSHAPHAGUS Mahdihassan

(Key couplet: 97. Figs 46, 77, 368)

Lakshaphagus Mahdihassan, 1931: 170. Type-species: *Microterys hautefeuillei* Mahdihassan, by original designation.

Cheilonicetus Shafee, Alam & Agarwal, 1975: 55. Type-species: *Cheilonicetus daulai* Shafee, Alam & Agarwal, by original designation.

DISTRIBUTION AND SPECIES. Three species, all from India: *daulai* (Shafee, Alam & Agarwal, 1975: 58), *fusiscapus* (Agarwal, 1965: 63) and *hautefeulli* (Mahdihassan; Hayat, 1981: 22).

REFERENCE. Review: Hayat (1981*b*: 21–23).

BIOLOGY. Parasites of Asterolecaniidae and Keriidae (Homoptera).

COMMENTS. The genus is superficially very similar to *Atropates* Howard and *Anisophleps* Fidalgo. It can be separated from *Atropates* using the characters provided by Hayat (1981*b*), and from *Anisophleps* by the following: forewing lacking subapical fuscous band, mesoscutum lacking posterior depression, whereas in *Anisophleps* the forewing has a subapical fuscous band and the mesoscutum has a transverse posterior depression as in *Diversinervus*.

Lakshaphagus is probably close to *Cerapterocerus* (tribe Cerapterocerini) from which it differs in lacking a flattened flagellum and weaker, less well-defined infusate pattern of the forewing.

LAMENNAISIA Girault

(Key couplets: 322, 532. Fig. 188)

Lamennaisia Girault, 1922*a*: 40. Type-species: *Lamennaisia quadridentata* Girault, by monotypy.

Mercetencyrtus Trjapitzin, 1963: 886. Type-species: *Encyrtus ambiguus* Nees, by original designation.

Syn. n.

Sabirella Agarwal, Agarwal & Khan, 1980: 30. Type-species: *Sabirella indica* Agarwal, Agarwal & Khan, by original designation. **Syn. n.**

DISTRIBUTION AND SPECIES. Four species, cosmopolitan; three from review area: *ambigua* (Nees; Mercet, 1921: 283) (**comb. n.** from *Encyrtus*) (India), *indica* (Agarwal, Agarwal & Khan, 1980: 30) (**comb. n.** from *Sabirella*) (India) and *quadridentata* Girault (1922*a*: 40) (Australia), also undetermined material from India and S. China to Australia, New Zealand and Hawaiian Is. (BMNH, BPBM, DSIR, HC).

BIOLOGY. Unknown, but possibly some of the New Zealand material was reared from larvae of Lathridiidae (Coleoptera).

COMMENTS. We are unable to place the genus according to Trjapitzin's (1973*b*) classification of the Encyrtinae.

LEEFMANSIA Waterston

(Key couplet: 383)

Leefmansia Waterston, 1928*b*: 527. Type-species: *Leefmansia bicolor* Waterston, by original designation.

DISTRIBUTION AND SPECIES. One species only, Australasia: *bicolor* Waterston (1928*b*: 528) (Moluccas, Bismarck Archipelago, New Hebrides).

BIOLOGY. Parasites of eggs of Tettigoniidae (Orthoptera).

COMMENTS. The genus is superficially extremely similar to *Microterys*, but we believe that it should be treated as distinct. It can be separated from *Microterys* by the characters given in the key, notably the axillae being separated by the posterior margin of the mesoscutum. This character, together with the fact that the only included species is parasitic in the eggs of other insects, leads us to believe that the genus is more closely related to *Ooencyrtus* (Microterysiini, Ooencyrtina) than to *Microterys*.

LEPTOMASTIDEA Mercet

(Key couplets: 149, 245, 276. Fig. 163)

Leptomastidea Mercet, 1916*b*: 112. Type-species: *Leptomastidea aurantiaca* Mercet, by monotypy.

Tanaomastix Timberlake, 1918: 362. Type-species: *Paraleptomastix abnormis* Girault, by original designation.

Leptanusia De Santis, 1964: 80. Type-species: *Leptomastidea pseudococci* Brèthes, by original designation.

DISTRIBUTION AND SPECIES. Seventeen species, cosmopolitan; two from review area: *abnormis* (Girault, 1915b: 184) (Hawaiian Is.) and *shafeei* Hayat & Subba Rao (1981: 114) (= *indica* Shafee, Alam & Agarwal, 1975: 24) (India), also at least four further species amongst undetermined material from India, Philippines and Australia (BMNH).

REFERENCE. Mercet (1924: 252–258).

BIOLOGY. Parasites of Pseudococcidae (Homoptera).

COMMENTS. *Leptomastidea* is in the tribe Anagyrini, subtribe Anagyrina (= *Leptomastidea* **syn. n.**). The genus is very close to *Gyranusoidea* on one hand and *Leptomastix* on the other. It can be separated from *Gyranusoidea* by the sculpture of the head and thorax and the degree of infuscation of the forewing (see comments under *Gyranusoidea*), and from *Leptomastix* by its generally smaller size and relatively shorter funicle segments in relation to the pedicel (see also Kerrich, 1982: 402).

LEPTOMASTIX Förster

(Key couplets: 230, 276. Figs 164, 168)

Leptomastix Förster, 1856: 34. Type-species: *Leptomastix histrio* Mayr, by subsequent reference of Mayr (1876: 730).

Sterrhocoma Förster, 1856: 36. Type-species: *Sterrhocoma histrio* Förster, by original designation.

Stenoterys Thomson, 1876: 115. Type-species: *Stenoterys orbitalis* Thomson, by monotypy.

DISTRIBUTION AND SPECIES. Thirty-three species, cosmopolitan; 13 from review area: *aligarhensis* Khan & Shafee (1975: 194) (India), *auraticorpus* Girault (1915a: 152) (Australia), *brevipediculus* Khan & Shafee (1975: 194) (India), *brevis* Hayat, Alam & Agarwal (1975: 14) (India), *dactylopii* Howard; Dozier (1927: 267) (Pakistan, India, Hawaiian Is.), *gunturiensis* Shafee ((1971: 49) (India), *longicornis* Khan & Shafee (1975: 195) (India), *longiscapus* Khan & Agarwal (1976: 378) (India), *nigritegulae* Girault (1915a: 153) (Australia), *nigrocoxalis* Compere (1928: 219) (India), *salemensis* Hayat, Alam & Agarwal (1975: 17) (India), *singularis* Shafee (1971: 50) (India) and *trilongifasciata* Girault (1916c: 479) (Java), also undetermined material, undoubtedly including several undescribed species, from India, Bangladesh, Laos, China, Java, Philippines and Papua New Guinea (BMNH, BPBM, RMNH, GC, HC).

BIOLOGY. Parasites of Pseudococcidae (Homoptera).

COMMENTS. *Leptomastix* belongs to the tribe Anagyrini, subtribe Anagyrina and is most closely related to *Leptomastidea* and *Apoleptomastix*. It can be separated from these genera by the characters given in the key (see also Kerrich, 1982: 402).

LEUROCERUS Crawford

(Key couplet: 112. Fig. 53)

Leurocerus Crawford, 1911: 276. Type-species: *Leurocerus ovivorus* Crawford, by original designation.

DISTRIBUTION AND SPECIES. Two species known, both from review area: *hongkongensis* Subba Rao (1971: 220) (S. China, Hong Kong) and *ovivorus* Crawford (1911: 277) (Philippines, Sumatra).

BIOLOGY. Parasites of eggs of Amathusiidae and Satyridae (Lepidoptera).

COMMENTS. The genus is placed in the tribe Microterytini, subtribe Ooencyrtina which may be correct, although it does appear to have some affinities with *Pentelicus* (see comments under *Pentelicus*), *Proleurocerus* (placed in the tribe Proleurocerini by Trjapitzin, 1973b), *Zozoros*,

Paksimmondsius and *Proleuroceroides*. It may be that these genera form a single group (or tribe), but it would require a further, more detailed morphological study to determine their true relationship. All these genera have similar forewing venation and a characteristic naked streak from the apex of the postmarginal vein to the apex of the stigmal vein (this character is also found in some genera of the Cerapterocerini and Cheiloneurini).

LUTHERISCA Ghesquière

(Key couplets: 123, 483, 490. Figs 239, 240)

Lutheria Girault, 1919a: 166. Type-species: *Lutheria ajanea* Girault, by original designation. [Homonym of *Lutheria* Hofsten, 1907.]

Lutherisca Ghesquière, 1946: 369. [Replacement name for *Lutheria* Girault.]

DISTRIBUTION AND SPECIES. One species, Singapore and possibly Borneo: *ajanea* (Girault, 1919a: 167).

BIOLOGY. Unknown.

COMMENTS. The single, extant, syntype of *Lutheria ajanea* (BMNH) is here designated LECTOTYPE. It is lacking the head which presumably was put on a microscope slide by Girault and has since been lost. The specimen from Borneo (BPBM) is almost certainly conspecific, but differs slightly from the lectotype in colour and sculpture of the dorsum of the thorax.

The genus is closely related to *Taftia* (tribe Chrysoplatygerini, subtribe Taftiina) and can be separated from this genus by the characters given in the key, notably the relatively larger clava (Fig. 239).

MAHENCYRTUS Masi

(Key couplets: 253, 304, 350, 417. Figs 147, 210)

Mahencyrtus Masi, 1917b: 157. Type-species: *Mahencyrtus occultans* Masi, by monotypy.

Tyndarichoides Mercet, 1921: 649. Type-species: *Tyndarichoides metallicus* Mercet, by original designation. [Homonym of *Tyndarichoides* Girault, 1920.] **Syn. n.**

Protyndarichus Mercet, 1923b: 479. [Replacement name for *Tyndarichoides* Mercet.] **Syn. n.**

DISTRIBUTION AND SPECIES. Five species, cosmopolitan; three from review area, all Australian: *aereifemur* (Girault, 1922e: 150) (**comb. n.** from *Echthrogonatopus*), *gracilis* (Girault, 1915a: 100) (**comb. n.** from *Zarhopaloides*) and *longifasciatipennis* (Girault, 1915a: 100) (**comb. n.** from *Zarhopaloides*), also further material, containing at least one undescribed species, from India, S. China, Hong Kong, Thailand, Malaysia, Java, Philippines and Australia (BMNH, BPBM).

BIOLOGY. Unknown.

COMMENTS. The holotype of *Mahencyrtus occultans* has been examined (BMNH). It is a typical male of the genus previously known as *Protyndarichus*. The genus has been synonymised with *Parechthrodryinus* by Trjapitzin & Gordh (1978a) but after studying material belonging to these two genera we believe that *Protyndarichus* and thus *Mahencyrtus* is a valid genus. It differs from *Parechthrodryinus* by the characters given in the key, but most notably by general body shape and also by the structure of the propodeum and scutellum. We propose the following transfers to *Mahencyrtus* for extra-limital species: *comara* Walker (from *Encyrtus*) and *nitidus* Howard (from *Encyrtus*) (both **comb. n.**).

The genus is placed in the tribe Cheiloneurini (Encyrtinae).

MANICNEMUS Hayat

(Key couplet: 242. Figs 145, 369, 370)

Manicnemus Hayat, 1981b: 23. Type-species: *Tetralophidea indica* Mani & Saraswat, by original designation.

DISTRIBUTION AND SPECIES. Afrotropical, Oriental, Australasian; one described species: *indicus* (Mani & Saraswat; Hayat, 1981b: 24) (India), also undetermined material from S. China, Hong Kong, Indonesia, Irian Jaya and Bismarck Archipelago (BPBM).

BIOLOGY. Unknown.

COMMENTS. The genus belongs in the tribe Charitopidini (Tetracneminae) and can be separated from related genera by the strongly infusate forewings, relatively short marginal vein of the forewing and very transverse head in dorsal view.

MARXELLA Girault

(Key couplet: 48)

Marxella Girault, 1932a: 6. Type-species: *Marxella richteri* Girault, by monotypy.

DISTRIBUTION AND SPECIES. One species, Australia only: *richteri* Girault (1932a: 6).

BIOLOGY. Unknown.

COMMENTS. The genus is very close to *Acerophagoides* and *Coccidoxenoides* (Tetracneminae, tribe Pauridiini) but differs in having a three-segmented funicle in the female, whereas the other genera have a five- and six-segmented funicle respectively.

MASHHOODIA Shafee

(Key couplets: 266, 407. Fig. 159)

Mashhoodia Shafee, 1972: 159. Type-species: *Mashhoodia indica* Shafee, by original designation.

DISTRIBUTION AND SPECIES. One species, India only: *indica* Shafee (1972: 160).

BIOLOGY. Parasites of Pseudococcidae (Homoptera).

COMMENTS. The genus belongs to the tribe Anagyrini, subtribe Anagyrina (Tetracneminae) and differs from other included genera in the characteristic venation of the forewing (more or less punctiform marginal vein and relatively long postmarginal and stigmal veins) and the patterns of light and dark setae on the forewing (Fig. 159).

MASHHOODIELLA Hayat

(Key couplets: 257, 378. Fig. 194)

Mashhoodiella Hayat, 1972: 209. Type-species: *Mashhoodiella echthromorpha* Hayat, by original designation.

DISTRIBUTION AND SPECIES. One species, India only: *echthromorpha* Hayat (1972: 210).

BIOLOGY. Parasites of Coccidae (Homoptera).

COMMENTS. Placement of this genus is difficult but it should belong in the tribe Aphycini (Encyrtinae) and appears to have some characters in common with *Parablastothrix* (see comments under *Parablastothrix*).

MAYRIDIA Mercet

(Key couplets: 191, 333, 435, 473)

Mayridia Mercet, 1921: 426. Type-species: *Mayridia pulchra* Mercet, by original designation.

Superprionomitus Mercet, 1921: 376. Type-species: *Superprionomitus procerus* Mercet, by original designation.

Indoencyrtus Hayat & Verma, 1978: 361. Type-species: *Indoencyrtus caeruleus* Hayat & Verma, by original designation.

DISTRIBUTION AND SPECIES. Twenty-four species, cosmopolitan except perhaps the Neotropics;

two species from review area: *caerulea* (Hayat & Verma, 1978: 362) (India) and *pulchra* Mercet (1921: 431) (India), also undetermined material, containing at least one undescribed species, from India, Sri Lanka, Hong Kong, Malaysia and Australia (BMNH, BPBM, HC).

BIOLOGY. Parasites of Acleridae and Pseudococcidae (Homoptera) and Cecidomyiidae (Diptera).

COMMENTS. Trjapitzin (1973*b*) places the genus in the subtribe Mayridiina which he incorrectly places in the tribe Miraini. *Mira* belongs to the subfamily Tetracneminae whilst *Mayridia* belongs in the Encyrtinae. In our view, the most realistic solution to the problem this creates would be the transfer of the subtribe Echthroplexiellina (also incorrectly included in the Miraini) to the Aphycini and the Mayridiina to the Cheiloneurini.

MENISCOCEPHALUS Perkins

(Key couplets: 425, 441, 476)

Meniscocephalus Perkins, 1906: 249. Type-species: *Meniscocephalus eximius* Perkins, by monotypy.
Helmecephala Noyes, 1980: 200. Type-species: *Helmecephala albisetosa* Noyes, by original designation.

Syn. n.

DISTRIBUTION AND SPECIES. Four described species, Neotropical, Oriental, Australasian; two species from review area: *exflores* (Trjapitzin, 1982*b*: 1603–1604) (**comb. n.** from *Helmecephala*) (Indonesia) and *eximius* Perkins (1906: 249) (Malaysia, Australia), also further undetermined material, including several undescribed species, from India to Australia (BMNH, BPBM, QM).

BIOLOGY. Parasites of nymphs of Cicadellidae (Homoptera).

COMMENTS. We are unable to place the genus according to Trjapitzin's (1973*b*) classification, but it may be related to genera included in the tribe Prionomasticini (see Noyes, 1980: 202) or, as Trjapitzin (1982*b*) suggests, it may belong in the tribe Cheiloneurini, subtribe Tyndarichina.

MESANUSIA Girault

(Key couplet: 203)

Blatticida Girault, 1915*a*: 94. Type-species: *Blatticida ashmeadi* Girault, by original designation.
[Homonym of *Blatticida* Ashmead, 1904.] **Syn. n.**

Mesanusia Girault, 1922*d*: 208. Type-species: *Mesanusia laticapus* Girault, by monotypy.

Blatticidella Gahan & Fagan, 1923: 22. [Replacement name for *Blatticida* Girault.] **Syn. n.**

DISTRIBUTION AND SPECIES. Two described species, Australia only: *ashmeadi* (Girault, 1915*a*: 94) (**comb. n.** from *Blatticida*) and *laticapus* Girault (1922*d*: 208), also one further undescribed species from Papua New Guinea (BPBM).

BIOLOGY. Parasites of eggs of cockroaches (Orthoptera, Blattodea) and Tettigoniidae (Orthoptera).

COMMENTS. *Mesanusia speciosa* (see p. 353) does not belong in this genus and we are unable to place it with any degree of certainty.

Mesanusia is related to *Ooencyrtus* (Microteriyini, subtribe Ooencyrtina) from which it can be separated by the very large, obliquely truncate clava and relatively longer marginal vein of the forewing.

MESASTYMACHUS Girault

Mesastymachus Girault, 1923*c*: 142. Type-species: *Mesastymachus silvae* Girault, by monotypy.

DISTRIBUTION AND SPECIES. One species, Australia only: *silvae* Girault (1923*c*: 142).

BIOLOGY. Unknown.

COMMENTS. Unfortunately the type(s) of *silvae* appear to be lost and therefore the generic and specific names will have to be regarded as nomina dubia. However, when the Australian encyrtid fauna is better known, it should be possible to recognise the genus and possibly even the species from Girault's meagre description.

MESOCALOCERINUS Girault

(Key couplet: 255)

Mesocalocerinus Girault, 1922d: 206. Type-species: *Mesocalocerinus gemmus* Girault, by monotypy.

DISTRIBUTION AND SPECIES. One species, Australia only: *gemma* Girault (1922d: 206).

BIOLOGY. Unknown.

COMMENTS. Very close to *Cheiloneurus* and quite possibly should be considered synonymous. However, we are retaining it as a distinct genus until the genera belonging to this difficult group can be studied in more detail. For the present it can be separated from *Cheiloneurus* on the combination of the basal cell of the forewing being setose to the base, the scutellum lacking a subapical tuft of setae and the basal segment of the gaster being orange and contrasting with the dark remainder (in *Cheiloneurus* the basal cell is usually bare in its proximal half or so, the scutellum usually has a subapical tuft of setae and the gaster is usually unicolorous; the combination of these characters is never the same as in *Mesocalocerinus*).

MESORHOPELLA Girault

(Key couplet: 71)

Mesorhopella Girault, 1923c: 145. Type-species: *Mesorhopella emersoni* Girault, by monotypy.

DISTRIBUTION AND SPECIES. One species, Australia only: *emersoni* Girault (1923c: 145).

BIOLOGY. Unknown.

COMMENTS. The genus is extremely close to *Pararhopella* from which it differs by the characters given in the key. Both genera probably belong in the tribe Trechnitini and can be distinguished from related genera by the five-segmented funicle, very elongate clava (longer than funicle), absence of notaular lines on the mesoscutum and relatively small size, not being much larger than 0.75 mm (excluding ovipositor).

METAPHAENODISCUS Mercet

(Key couplet: 480. Fig. 237)

Metaphaenodiscus Mercet, 1921: 626. Type-species: *Metaphaenodiscus nemoralis* Mercet, by original designation.

Keatsia Girault, 1928a: 1. Type-species: *Keatsia umbilicata* Girault, by monotypy. **Syn. n.**

Ramalia Ferrière, 1953: 27. Type-species: *Tetralophidea maxima* Mercet, by original designation.

DISTRIBUTION AND SPECIES. Ten species, Palaearctic, Afrotropical, and Australasian; four from review area: *aligarhensis* Hayat (1981b: 25) (India), *proximus* (Hayat, 1981b: 26) (India), *umbilicatus* (Girault, 1928a: 1) (**comb. n.** from *Keatsia*) (Australia) and *yasumatsui* Myartseva & Trjapitzin (1979: 1238), also further undetermined material from S. China, Java and Australia (BMNH, BPBM).

BIOLOGY. Parasites of Pseudococcidae (Homoptera).

COMMENTS. Belongs to the tribe Aenasiini (see comments under *Aenasius*) and distinguished from related genera by the very broad, menisciform head and the relatively long marginal and short postmarginal and stigmal veins of the forewings.

METAPHYCUS Mercet

(Key couplets: 180, 377. Fig. 104)

Metaphycus Mercet, 1917a: 138. Type-species: *Aphycus zebratus* Mercet, by monotypy.*Mercetiella* Dozier, 1926: 98. Type-species: *Mercetiella reticulata* Dozier, by original designation.*Oaphycus* Girault, 1932a: 5. Type-species: *Aphycus sanguinithorax* Girault, by original designation.**Syn. n.***Melanaphycus* Compere, 1947a: 5. Type-species: *Pseudococcobius fumipennis* Timberlake, by original designation.*Anaphycus* Sugonjaev, 1960: 372. Type-species; *Aphycus nitens* Kurdjumov, by original designation.*Notoencyrtus* De Santis, 1964: 211. Type-species: *Notoencyrtus guttofasciatus* De Santis, by original designation.

DISTRIBUTION AND SPECIES. About 200 described species, cosmopolitan; 38 from review area: *agarwali* Hayat & Subba Rao (1981: 115) (= *laticapus* Shafee, Alam & Agarwal, 1975: 84) (India), *alberti* (Howard; Annecke & Mynhardt, 1981: 38) (Hawaiian Is.), *angustifrons* Compere (1957: 227) (Taiwan), *argenteus* (Girault, 1936: 1) (**comb. n. from *Aphycus***) (Australia), *atriclathra* (Girault, 1936: 1) (**comb. n. from *Aphycus***) (Australia), *bicinctitibiae* (Girault, 1932c: 1) (**comb. n. from *Aphycopsis***) (Australia), *bowenesis* (Girault, 1932a: 4) (**comb. n. from *Aphycus***) (Australia), *buderimi* (Girault, 1936: 1) (**comb. n. from *Aphycus***) (Australia), *cerococci* (Shafee, Alam & Agarwal, 1975: 83) (India), *citricola* Annecke & Mynhardt (1971: 333) (Pakistan), *claviger* (Timberlake, 1916: 620) (New Zealand), *crotolariae* (Shafee, Alam & Agarwal, 1975: 85) (India), *flavus* (Howard; = *hesperidum* Mercet, 1916: 784) (India, Hawaiian Is.), *fuscidorsum* (Gahan, 1919: 521) (**comb. n. from *Aphycus***) (India), *gontsharenkoi* Trjapitzin & Khlopunov (1976: 98) (Vietnam), *helvolus* (Compere; Annecke & Mynhardt, 1981: 42) (Pakistan, Bangladesh); *indicus* Shafee, Alam & Agarwal (1975: 79) (India), *iohneumon* (Girault, 1936: 1) (**comb. n. from *Aphycus***) (Australia), *keatsi* (Girault, 1932a: 4) (**comb. n. from *Aphycus***) (Australia), *laticapus* Alam (1972: 134) (India), *lichtensiae* (Howard; Compere & Annecke, 1961: 35) (Pakistan, India, Sri Lanka), *longiclavatus* (Shafee, Alam & Agarwal, 1975: 88) (India), *lounsburyi* (Howard, 1898b: 244) (Hawaiian Is.), *maculatus* Agarwal (1965: 89) (India), *malabarensis* (Mukerjee in Saraswat & Mukerjee, 1975: 46) (India), *memnonicus* Compere (1940: 46) (Australia), *mexicanus* (Howard, 1898b: 247) (Hawaiian Is.), *nigrivarius* (Girault, 1929b: 313) (**comb. n. from *Aphycus***) (Australia), *parkeri* (Girault, 1932a: 1) (**comb. n. from *Aenasomyiella***) (Australia), *portoricensis* (Dozier, 1926: 100) (Hawaiian Is.), *sanguinithorax* (Girault, 1915a: 112) (**comb. n. from *Aphycus***) (Australia), *semialbus* (Girault, 1932a: 5) (**comb. n. from *Aphycus***) (Australia), *stanleyi* (Compere; Compere & Annecke, 1961: 33) (Hawaiian Is.), *timberlakei* (Ishii, 1923: 108) (New Zealand), *tricinctus* (Girault, 1931a: 4) (**comb. n. from *Aphycus***) (Australia), *turneri* (Girault, 1932a: 5) (**comb. n. from *Aphycus***) (Australia), *varius* (Girault, 1915a: 178) (**comb. n. from *Aenasioidea***) (Australia), *verdini* (Girault, 1936: 1) (**comb. n. from *Aphycus***) (Australia), *zebratus* (Mercet, 1917a: 138) (India), also much undetermined material from throughout the region (BMNH, BPBM, DSIR, QM, ANIC, GC, HC).

REFERENCES. Timberlake (1916: 587–639); Afrotropical species, with descriptions of some relevant species: Annecke & Mynhardt (1971; 1972; 1981); review of some Indian species: Shafee *et al.* (1975: 78–88).

BIOLOGY. Parasites of Coccidae, Diaspididae, Keriidae, Asterolecaniidae and Eriococcidae (Homoptera).

COMMENTS. *Mesanusia speciosa* Girault (see p. 353) may also belong in this genus, but this will only be confirmed when fresh material is collected.

Metaphycus argenteus and *iohneumon* may be synonymous, also *crotolariae* may be synonymous with *fuscidorsum*.

The genus is placed in the tribe Aphycini, subtribe Paraphycina (Encyrtinae) (see comments under *Paraphycus*).

MICROTERTYS Thomson

(Key couplets: 94, 102, 139, 237, 261, 383)

Sceptrophorus Förster, 1856: 34. Type-species: *Encyrtus sceptriger* Förster, by designation of Ashmead (1900b: 381) [Suppressed in favour of *Microterys* Thomson: Opinion 1110, 1978, *Opin. Decl. int. Commn zool. Nom.* 35: 99–100.]

Microterys Thomson, 1876: 155. Type-species: *Encyrtus sylvius* Dalman, by designation of Ashmead (1900: 390).

Apentelicus Fullaway, 1913: 26. Type-species: *Apentelicus kotinskyi* Fullaway, by original designation.

DISTRIBUTION AND SPECIES. Very nearly 150 described species, cosmopolitan; 20 from review area: *anomalococci* Shafee, Alam & Agarwal (1975: 69) (India), *aristotelea* (Girault; Prinsloo, 1976b: 414) (Australia), *australicus* Prinsloo (1976b: 420) (Australia), *clauseni* Compere (1926: 35) (Pakistan), *ditaeniatus* Huang (1980: 432, 434) (S. China), *flavus* (Howard; = *frontalis* Mercet, 1921: 413) (Pakistan, India, Sri Lanka, Australia, New Zealand, Hawaiian Is.), *garibaldia* (Girault; Prinsloo, 1976b: 417) (Australia), *gilberti* (Girault; Prinsloo, 1976b: 411) (Australia), *hesperidum* (Trjapitzin & Khlopunov, 1976: 101) (Vietnam), *indicus* Subba Rao (1977: 13) (India), *kerrichi* Shafee, Alam & Agarwal (1975: 69) (India), *lichtensiae* (Howard in Howard & Ashmead, 1896: 636) (Sri Lanka), *longifuniculus* (Girault, 1932b: 1) (Australia), *mirzai* Shafee, Alam & Agarwal (1975: 67) (India), *newcombi* (Girault; Prinsloo, 1976b: 413) (Malaysia, Australia), *nietneri* (Motschulsky, 1859: 170) (Sri Lanka), *purpureiventris* (Girault; Prinsloo, 1976b: 417) (Australia), *sinicus* Jiang (1982: 180, 186) (S. China), *spinozai* (Girault; Prinsloo, 1976b: 415) (Australia) and *triguttatus* (Girault; Prinsloo, 1976b: 414) (Australia), also much undetermined material, including several undescribed species, from throughout the region (BMNH, BPBM, QM, ANIC, USNM, HC).

REFERENCES. World catalogue: Rosen (1976); review of some species: Shafee *et al.* (1975: 65–71); review of Australian species: Prinsloo (1976b).

BIOLOGY. Parasites of Coccidae, Kermococcidae and Lecanodiaspididae (Homoptera).

COMMENTS. One undescribed species from Brunei (BMNH) has an apical tuft of setae on the scutellum similar to that found in *Cheiloneurus*.

The types of *Microterys coeruleus* Bingham (HDOU) have been examined by Z. Bouček who informs us that the female belongs to *Tetrastichus* (Eulophidae) and the male to *Anastatus* (Eupelmidae).

Placed in the tribe Microterysiini, subtribe Microterysiina (Encyrtinae).

MIRA Schellenberg

(Key couplet: 77)

Mira Schellenberg, 1803: 68. Type-species: *Mira mucora* Schellenberg, by monotypy.

Dicelloceras Menzel, 1855: 270. Type-species: *Dicelloceras vibrans* Menzel, by monotypy.

Euryscapus Förster, 1856: 32. Type-species: *Encyrtus platycerus* Dalman, by original designation.

Lonchocerus Dahlbom, 1857: 292. Type-species: *Encyrtus platycerus* Dalman, by subsequent reference of Thomson (1876: 130).

Euzkadia Mercet, 1921: 552. Type-species: *Euzkadia integralis* Mercet, by original designation.

DISTRIBUTION AND SPECIES. Four described species, Palaearctic; one undescribed species from Australia (BMNH, UCR).

REFERENCE. Revision of European species: Bouček (1977b: 141–146).

BIOLOGY. Unknown.

COMMENTS. The genus has been incorrectly placed in the subfamily Encyrtinae by Trjapitzin (1973b). It is actually very close to the genera included in the tribe Charitopidini (Tetracnemiinae).

MONSTRANUSIA Trjapitzin

(Key couplet: 118)

Monstranusia Trjapitzin, 1964b: 243. Type-species: *Monstranusia mirabilissima* Trjapitzin, by original designation.

DISTRIBUTION AND SPECIES. Two species, Palearctic, Afrotropical, Oriental; both known from Oriental region: *antennata* (Narayanan, 1960: 122) (India) and *mirabilissima* Trjapitzin (1964b: 245) (Pakistan).

BIOLOGY. Unknown.

COMMENTS. Placed in the tribe Anagryini, subtribe Anusiina (Tetracneminae) by Trjapitzin (1973a), but possibly this may be incorrect since it also shows many characters in common with the Tetracnemini, e.g. forewing venation and infuscation.

MOZARTELLA Girault

(Key couplet: 65)

Mozartella Girault, 1926a: 1. Type-species: *Mozartella beethoveni* Girault, by monotypy.

DISTRIBUTION AND SPECIES. One species, Australia only: *beethoveni* Girault (1926a: 1).

BIOLOGY. Apparently reared from plant galls.

COMMENTS. The genus superficially appears to be very close to *Pseudectroma* and *Acerophagus* (tribe Aphycini, subtribe Aphycina) but differs in the mandible having two teeth and a broad truncation instead of three teeth. This character may indicate a relationship with *Aphycomorpha* which has been placed in the tribe Aphycini by Trjapitzin (1973b) but which we now believe belongs in the Microteriyini (see comments under *Aphycomorpha*).

MULUENCYRTUS gen. n.

(Key couplet: 458. Figs 215, 216, 371–373)

Type-species: *Muluencyrtus nudipennis* sp. n. Gender: masculine.

♀. *Head*. In frontal view slightly broader than long and in side view about twice as long as broad and anteriorly more or less gradually and evenly rounded. Eye relatively small with sparse, short, inconspicuous setae each not longer than the diameter of a facet, posterior margin of eye straight, eye a little less than one-third longer than broad, not quite reaching occipital margin which is sharply carinate behind ocelli. Malar space slightly longer than eye, sulcus absent, but more or less indicated by a change of sculpture; mouth opening relatively small, about two-fifths head width. Frontoververtex about two-fifths head width; ocelli in a right angle, the posterior ones a little closer to eye margin than to occipital margin, separated from the latter by about their own major diameters. Antennal scrobes only a little longer than toruli, gently curved inwards but not meeting dorsally, reaching about half way from antennal toruli to anterior ocellus; antennal torulus separated from mouth margin by slightly more than its own length and from other torulus by about one and one-half times its own length, its dorsal margin a little below ventral eye margin; clypeus very shallowly excised, but broadly concave. Antennal scape distinctly longer than width of frontoververtex, subcylindrical, slightly more than four and one-half times as long as broad, with a pair of short flanges on its lower surface either side of pedicel and clothed in conspicuous long setae; pedicel cylindrical, about one-third length of scape, shorter than any of the first three funicle segments but longer than any of the last three; clava entire, transversely truncate about one-third length of funicle; longitudinal sensillae on all flagellar segments except perhaps the first two; setae on flagellum moderately long, the longest being slightly longer than diameter of first funicle segment. Frontoververtex above scrobes with shallow, raised, squamiform-reticulate sculpture; between scrobes and eyes and interantennal prominence dorsally with rough, raised, irregular sculpture, this continuing onto lower parts of face but becoming shallower and more longitudinally elongate; setae on frontoververtex and, to a less extent, on lower parts of

face but borne in shallow, but distinct punctures; setae moderately sparse, short and inconspicuous on frontovertex above toruli, but longer and more conspicuous on genae and lower parts of interantennal prominence. Mandible broad with two teeth and a broad truncation; maxillary palpus four-segmented, labial palpus three-segmented.

Thorax. Moderately robust in side view, with mesoscutum more or less flat but slightly convex anteriorly and scutellum very slightly convex; the metapleurum and propodeum together narrowly in contact with hind coxa. In dorsal view pronotum moderately concave posteriorly, with spiracles clearly visible laterally; visible part of mesoscutum slightly less than twice as broad as long, with notaular lines absent, its hind margin slightly produced distad; axillae slightly separated; scutellum slightly shorter than mesoscutum and slightly broader than long, its apex more or less acute; propodeum medially a little less than one-quarter length of scutellum. Dorsum of thorax with very shallow, raised, squamiform-reticulate sculpture; mesopleurum more or less smooth and shiny; propodeum more or less smooth; dorsum of thorax clothed with very short, inconspicuous dark setae. Forewing infusate, about two and one-half times as long as broad; linea calva not interrupted or closed; dorsal surface of forewing with extremely sparse discal setae, apart from a few setae in basal cell and filum spinosum almost naked dorsally, those on dorsal surface clearly much less dense than those ventrally; submarginal vein without an apical hyaline break, parastigma not swollen; costal cell about nine or ten times as long as broad, with only one seta dorsally near apex; marginal vein about twice as long as broad, about as long as postmarginal and a little longer than half stigmal vein. Hindwing about two-thirds length of forewing, very slightly infumate, about three and one-half times as long as broad; marginal fringe about one-ninth as long as maximum wing width. Mid tibial spur about one-half as long as basal mid tarsal segment; all legs very smooth; hind and mid tarsi very characteristic, being very smooth and shiny and gradually tapering towards apex; hind tibia with apex strongly oblique (Fig. 216).

Gaster. About as long as thorax; cercal plates in apical one-third; hypopygium with apex reaching to about three-quarters along gaster; ovipositor not or only slightly exerted; paratergites presumably absent.

♂. Unknown.

COMMENTS. The affinities of this interesting new genus are not at all clear, but the head shape and structure, forewing venation and positioning of the cercal plates suggest that it should be placed near *Encyrtus*, *Olypusa* or perhaps *Eucomomorphella*. It can be easily separated from these genera by the nearly naked dorsal surface of the forewing and from *Encyrtus* and *Olypusa* by the smaller eyes and presence of mandibular teeth. The presence of mandibular teeth suggest that it is closest to *Eucomomorphella*, but this genus has a very long postmarginal vein and three-segmented clava (see comments under *Anagyrodus*).

Muluencyrtus nudipennis sp. n.

(Figs 215, 216, 371–373)

♀. Length, 2.06 mm.

Colour. Body, including legs and antenna, reddish brown to dark reddish brown; apex of clava whitish yellow; between each eye and occiput more or less orange-brown; mesoscutum with a slight bluish sheen; scutellum slightly purplish brassy; scutellum laterally either side of apex, metanotum and propodeum medially brown; forewing infusate as in Fig. 373.

Head. Frontal view as in Fig. 372. Relative measurements: head length 85, head width (frontal view) 100, head width (side view) 47, minimum width of frontovertex 39, POL 16, OOL 5, malar space 46, length of eye 43, width of eye 37, scape length 55, other proportions of antenna as in Fig. 371.

Thorax. Relative measurements: forewing length 220, hindwing length 153, hindwing width 45; forewing as in Fig. 373, venation as in Fig. 215, hind tibia and tarsus as in Fig. 216.

Gaster. Relative lengths: last tergite 46, [mid tibia 132].

♂. Unknown.

DISTRIBUTION. Sarawak.

BIOLOGY. Unknown.

MATERIAL EXAMINED

Holotype ♀, Sarawak: Gunong Mulu National Park, 26.v.1978 (*N. M. Collins*) (BMNH).

NASSAUIA Girault

(Key couplet: 50)

Nassauia Girault, 1932a: 5. Type-species: *Nassauia atoma* Girault, by monotypy.DISTRIBUTION AND SPECIES. Two species, Australia only: *atoma* Girault (1932a: 5) and *secunda* Girault (1932c: 3).

BIOLOGY. Reared from 'coccids' (Girault, 1932c: 3).

COMMENTS. The genus is near *Metaphycus* (tribe Aphycini, subtribe Paraphycina) and differs from all related genera in having a four-segmented funicle.**NATHISMUSIA** gen. n.

(Key couplet: 37. Figs 214, 374–376)

Type-species: *Nathismusia southwoodi* sp. n. Gender: feminine.

♀. *Head*. In facial view about one-quarter wider than long, with mouth opening very wide, about half head width, in side view head about two-thirds longer than wide and anteriorly more or less gradually curved. Eyes very small with posterior margin straight, almost oval, a little longer than broad, naked; eye separated from occipital margin, which is rounded, by at least about twice the diameter of an ocellus. Malar space about as long as an eye with sulcus absent but marked by a slight change of sculpture. Frontovertex about three-quarters head width, ocelli forming an obtuse angle of about 110°, the posterior ocelli separated from occipital margin by a little more than their diameter but from eye margin by about five times their diameter. Antennal scrobes extremely shallow, broadly semicircular, more or less meeting dorsally and reaching about half way from toruli to anterior ocellus; antennal torulus separated from mouth by a little less than its own length and from other torulus by about one and one-half times its own length, its upper margin a little above the lower eye margin; clypeus broadly but shallowly excised below and between toruli. Antennal scape a little longer than half minimum width of frontovertex, stout, a little more than three times as long as broad; pedicel conical, nearly half length of scape and clearly longer than any funicle segment, all subquadrate, the first the longest, the sixth the shortest; clava three-segmented, its apex rounded, sutures between segments subparallel; longitudinal sensillae on all flagellar segments; longest setae not much more than one-third as long as diameter of segments. Frontovertex with extremely shallow, raised reticulate sculpture, this becoming more elongate on lower parts of face and genae; setae on head moderately dense, very short, inconspicuous. Mouth parts not clearly visible in single specimen available.

Thorax. Moderately deep in side view, but conspicuously dorso-ventrally flattened, the mesoscutum and scutellum almost completely flat, the anterior face of the pronotum almost perpendicular, the metapleurum and propodeum fairly broadly in contact with hind coxa. In dorsal view hind margin of pronotum shallowly concave; visible part of mesoscutum slightly more than twice as broad as long, with notaular lines absent and its hind margin almost straight, only very slightly produced backwards; axillae nearly touching in middle, not clearly separated from scutellum which is nearly one-third longer than mesoscutum and apically rounded; propodeum medially less than one-seventh as long as scutellum. Dorsum of thorax with similar sculpture to frontovertex but a little deeper on posterior part of mesoscutum than on scutellum; mesopleurum with shallow, raised, slightly elongate, reticulate sculpture; propodeum almost completely smooth, but with some irregular sculpture near spiracle and laterally; setae on dorsum of thorax sparse, dark and short, very inconspicuous. Forewing lightly infused greyish brown, with a small dark brown spot immediately below marginal vein, wing nearly three times as long as broad with marginal fringe very short, nearly absent; linea calva completely obliterated by setae on both surfaces of wing; filum spinosum absent; setae in disc of forewing very dense, short and evenly distributed except near extreme base where they are virtually absent; submarginal vein with an indistinct hyaline break, parastigma hardly swollen; costal cell about 11 times as long as broad and with one line of setae dorsally in its proximal one-third and two or three lines of setae in its distal two-thirds or so; marginal vein thick, about twice as long as wide, longer than stigmal vein which in turn is longer than postmarginal. Hindwing lightly infused pale greyish brown, about two-thirds as long as forewing; marginal setae about one-seventh as long as maximum wing width. Mid tibial spur a little shorter than mid basal tarsal segment.

Gaster. Slightly longer than thorax with cercal plates in posterior half; hypopygium reaching apex of gaster; last tergite a little less than one-third as long as mid tibia; paratergites not visible, probably absent; ovipositor hardly exerted.

♂. Unknown.

COMMENTS. Placement of this genus is difficult, although it must certainly belong to the Encyrtinae. It may be related to *Coelopencyrtus* (tribe Copidosomatini, subtribe Ceelopencyrtina) since there are some similarities in head shape, forewing venation and structure of the gaster. However, it can easily be separated on the relatively small eyes, high placement of antennal toruli, lack of linea calva and very short last abdominal tergite.

The type-species of the genus is named in honour of Professor Sir T. R. E. Southwood.

Nathismusia southwoodi sp. n.

(Figs 214, 374–376)

♀. Length (holotype): 1.16 mm.

Colour. Generally dark brown; antenna yellowish brown; wings suffused very pale greyish brown, dark brown immediately below marginal vein of forewing; all coxae dark brown, femora dark brown, fore and mid femora apically yellow, tibiae and tarsi yellow, pretarsi dark brown.

Head. Relative measurements: head length 45, head width (facial view) 56, head width (side view) 27, minimum width of frontovertex 42, malar space 18, eye length 17.5, eye width 14, POL 13.5, OOL 16.5, scape length 23, scape width 7, proportions of antenna as in Fig. 374, head in facial view as in Fig. 375.

Thorax. Relative measurements: forewing length 165, forewing width 62, venation as in Figs 214, 376; hindwing length 115, hindwing width 27. Base of forewing as in Fig. 214.

Gaster. Relative lengths: last tergite 21, [mid tibia 62].

♂. Unknown.

DISTRIBUTION. India.

BIOLOGY. Unknown.

MATERIAL EXAMINED

Holotype ♀, **India:** Hyderabad, Patancheru, ICRISAT, vii–ix.1980, Malaise trap (*Bernays & Woodhead*) (BMNH).

NEABROLEPOIDEUS Girault

(Key couplet: 255)

Neabrolepoideus Girault, 1917g: 140. Type-species: *Neabrolepoideus bioculatus* Girault, by original designation.

DISTRIBUTION AND SPECIES. One described species, Australia only: *bioculatus* Girault (1917g: 141), also one further undescribed species from Australia (BMNH).

BIOLOGY. Unknown.

COMMENTS. The genus belongs to the tribe Cheiloneurini (Encyrtinae) and is very close to *Cheiloneurus* from which it more or less differs only by the setae of the forewing reaching nearer the base, the pattern of infuscation of the forewing, the scutellum being slightly more convex and lacking the apical tuft of setae, and the body (especially the antenna) being more slender (see comments under *Cheiloneurus*).

NEANAGYRUS Girault

(Key couplets: 495, 523)

Neanagyris Girault, 1915a: 174. Type-species: *Neanagyris capitatus* Girault, by original designation.

Anisodromus Riek, 1962c: 283. Type-species: *Anisodromus tarsius* Riek, by original designation. **Syn. n.**

DISTRIBUTION AND SPECIES. Three species, all Australian: *capitatus* Girault (1915a: 174), *niger* (Riek, 1962c: 285) (**comb. n.** from *Anisodromus*) and *tarsius* (Riek, 1962c: 283) (**comb. n.** from *Anisodromus*).

BIOLOGY. Parasites of lerp-forming Psyllidae (Homoptera).

COMMENTS. The genus is very close to *Psyllaephagus* (Trechnitini, subtribe Metaprionomitina) and perhaps should be considered as a species-group within that genus since it differs only in the structure of the antenna.

NEASTYMACHUS Girault

(Key couplets: 181, 312, 414. Fig. 101)

Neastymachus Girault, 1915a: 86. Type-species: *Neastymachus auraticorpus* Girault, by monotypy.
Nikolskiella Trjapitzin, 1962b: 560. Type-species: *Microterys luteus* Nikol'skaya, by original designation.

Syn. n.

Pseudmicroterys Shafee, Alam & Agarwal, 1975: 71. Type-species: *Pseudmicroterys burski* Shafee, Alam & Agarwal, by original designation. **Syn. n.**

DISTRIBUTION AND SPECIES. Provisionally eight species, Palaearctic, Afrotropical, Oriental, Australasian; five from review area: *angustifrons* (Shafee, Alam & Agarwal, 1975: 76) (**comb. n.** from *Pseudmicroterys*) (India), *auraticorpus* Girault (1915a: 86) (Australia), *burski* (Shafee, Alam & Agarwal, 1975: 73) (**comb. n.** from *Pseudmicroterys*) (India), *cerococci* (Shafee, Alam & Agarwal, 1975: 76) (**comb. n.** from *Pseudmicroterys*) (India) and *delhiensis* (Subba Rao, 1957: 387) (**comb. n.** from *Microterys*) (India), also undetermined material from Sri Lanka, Hong Kong and Malaysia (BMNH, BPBM).

REFERENCE. Review of some Indian species: Shafee *et al.* (1975: 71–78).

BIOLOGY. Parasites of Aclerdidae and Asterolecaniidae (Homoptera).

COMMENTS. *Neastymachus auraticorpus* Girault is very close to *luteus* Nikol'skaya (**comb. n.**), differing only slightly in the relative proportions of the antennal segments, forewings and width of frontovertex.

We have examined paratypes of *Nikolskiella japonica* Tachikawa (1970: 100). The species does not appear to belong in *Neastymachus* nor to any genus known to us. We have not seen any material of *Nikolskiella secunda* Trjapitzin (1962b: 565) and therefore defer formally transferring it to *Neastymachus*.

The genus is placed in the tribe Microterytini, subtribe Microterytina (Encyrtinae).

NEBLATTICIDA Girault

(Key couplet: 130)

Neblatticida Girault, 1915a: 96. Type-species: *Neblatticida fasciatiipes* Girault, by original designation.

DISTRIBUTION AND SPECIES. Three species, all Australian: *fasciatiipes* Girault (1915a: 96), *lotae* (Girault, 1922b: 106) (**comb. n.** from *Baeoanusia*) and *perfuscipennis* (Girault, 1915a: 164) (**comb. n.** from *Baeoanusia*).

BIOLOGY. Unknown.

COMMENTS. The generic placement of *perfuscipennis* is difficult. Girault originally included it in *Baeoanusia*, no doubt because of the similarity in the structure of the mandible. It is very probable that *perfuscipennis* belongs to neither *Neblatticida* nor *Baeoanusia* if these genera are defined as narrowly as they are at present. However, *perfuscipennis* will run to *Neblatticida* in the key to genera as it stands and therefore this necessitates the transfer of this species to *Neblatticida*.

Both *Neblatticida* and *Baeoanusia* belong to the Cheiloneurini (Encyrtinae) and a detailed study is required in order to achieve some idea of the natural grouping of the species, particularly those in Australia, before the generic limits can be determined with any degree of certainty. We feel that when such a study can be undertaken, very many of the genera recognised at present will fall in synonymy (see also comments under *Cheiloneurus*).

NEGENIASPIDIUS Trjapitzin

(Key couplet: 322)

Negeniaspidius Trjapitzin, 1982a: 39. Type-species: *Encyrtus nobilis* Nees, by original designation.

DISTRIBUTION AND SPECIES. Only one described species, Palearctic, Afrotropical and Oriental: *nobilis* (Nees; = *Coccidencyrtus pretiosus* Mercet, 1921: 281) (India).

BIOLOGY. Unknown.

COMMENTS. It is possible that the species occurring in southern Africa (Zambia, Zimbabwe) is distinct from *nobilis* (BMNH).

We are unable to place *Negeniaspidius* according to Trjapitzin's (1973b) classification of the Encyrtinae although quite possibly it is related to *Lamennaisia*.

NEOCHARITOPUS Hayat, Alam & Agarwal

(Key couplet: 502. Figs 243, 244, 380)

Neocharitopus Hayat, Alam & Agarwal, 1975: 24. Type-species: *Charitopus orientalis* Agarwal, by original designation.

Insleyia Prinsloo & Annecke, 1979: 377. Type-species: *Insleyia crassa* Prinsloo & Annecke, by original designation. **Syn. n.**

DISTRIBUTION AND SPECIES. Two species, Afrotropical, Oriental; one from review area: *orientalis* (Agarwal, 1965: 91) (India).

BIOLOGY. Parasites of Pseudococcidae (Homoptera).

COMMENTS. We have compared some paratypes of *Insleyia crassa* with material of *Neocharitopus orientalis* collected in India and find that they must be considered congeneric. Further study, using fresh material of *orientalis* for comparison, may reveal that the two species are also synonymous. The material of *orientalis* at hand is not in sufficiently good condition for reliable comparison at this level.

The genus belongs in the tribe Charitopidini (Tetracneminae) and is superficially very similar to *Manicnemus* from which it can be separated by the hyaline forewings and relatively short propodeum (not more than about one-fifth length of scutellum). The forewings of *Manicnemus* are strongly infusate and the propodeum is about half as long as the scutellum.

NEOCLADELLA Girault

(Key couplets: 110, 186. Figs 110, 111)

Neocladella Girault, 1915a: 99. Type-species: *Neocladella compressipes* Girault, by original designation.

Pteromalencyrtus Girault, 1915a: 116. Type-species: *Pteromalencyrtus quadridentatus* Girault, by original designation. **Syn. n.**

DISTRIBUTION AND SPECIES. One species, Australia only: *compressipes* Girault (1915a: 99) (= *Pteromalencyrtus quadridentatus* Girault, 1915a: 116 **syn. n.**).

BIOLOGY. Unknown.

COMMENTS. We favour the use of *Neocladella* as the valid generic name since the holotype of *compressipes* is in much better condition than that of *quadridentatus*.

Placement of the genus is difficult, but the wing venation suggests that it very probably belongs to the tribe Habrolepidini, subtribe Comperiellina. It is easily separated from genera included in this subtribe by the quadridentate mandible, relatively high placement of the antennal toruli on the head, relatively small scape and hyaline wings.

NEOCLADIA Perkins
(Key couplet: 36. Fig. 213)

Neocladia Perkins, 1906: 251. Type-species: *Neocladia howardi* Perkins, by monotypy.
Phyllotibia Risbec, 1954: 1071. Type-species: *Phyllotibia senegalensis* Risbec, by monotypy.

DISTRIBUTION AND SPECIES. Seven species, Afrotropical, Oriental, Australasian; four from review area: *howardi* Perkins (1906: 251) (Australia), *indica* (Agarwal, 1970: 25) (India), *shadsakus* (Mani & Kaul in Mani *et al.*, 1973: 74) (India) and *violacea* Masi (1926: 272) (**stat. n.** from subspecies of *howardi*) (Taiwan), also further undetermined material from India to Hong Kong and Australia (BMNH, BPBM).

BIOLOGY. Parasites of nymphs of Cicadellidae (Homoptera).

COMMENTS. We have examined the holotype of *Neocladia howardi violacea* Masi (IPK). It represents a valid species differing from *howardi* in the forewing venation (shorter marginal vein and less curved stigmal).

Placed in the tribe Neoclaudiini (Encyrtinae) which is possibly too narrowly defined by Trjapitzin (1973*b*) (see comments under *Anagyrodes*). It can be separated from other closely related genera by the combination of the enormously expanded and flattened hind tibia, sickle-shaped mandible, forewing with relatively long marginal vein, three-segmented clava and hypopygium more or less reaching the apex of the gaster.

NEODISCODES Compere
(Key couplets: 129, 210)

Neodiscodes Compere, 1931: 272. Type-species: *Neodiscodes martinii* Compere, by original designation.

DISTRIBUTION AND SPECIES. Seven species, Afrotropical, Oriental; four species from review area: *indicus* Narayanan & Subba Rao (1960: 75) (India, Pakistan), *lepellei* Kerrich (1953: 794) (India, Sri Lanka), *parvus* Kerrich (1967: 228) (S. China) and *subbaraoi* Kerrich (1967: 232) (Hong Kong, Java).

REFERENCE. Revision: Kerrich (1967: 228–235).

BIOLOGY. Parasites of Pseudococcidae (Homoptera).

COMMENTS. Here placed in the tribe Aenasiini (Tetracneminae) (see comments under *Aenasius*). It is very closely related to *Aenasius*, but can be separated by the relatively narrower frontovertex (see key, also Kerrich, 1967: 188–190).

NEODUSMETIA Kerrich
(Key couplet: 80. Figs 34, 377, 378)

Neodusmetia Kerrich, 1964*a*: 76. Type-species: *Dusmetia sangwani* Subba Rao, by original designation.

DISTRIBUTION AND SPECIES. One species known, New World, Afrotropical, Oriental and Australasian: *sangwani* (Subba Rao, 1957: 385) (Pakistan, India, Bangladesh, Philippines, Australia, Hawaiian Is.).

BIOLOGY. A parasite of *Antonina graminis* (Maskell) and has been successfully introduced into various parts of the world to control this mealybug (Homoptera, Pseudococcidae).

COMMENTS. We are unable to place the genus according to Trjapitzin's (1973*a*) classification of the Tetracneminae. It may be related to the genera of the Dinocarsini.

NEOPLATYCERUS Subba Rao
(Key couplet: 116. Fig. 56)

Neoplaticerus Subba Rao, 1965*b*: 150. Type-species: *Neoplaticerus tachikawai* Subba Rao, by original designation.

DISTRIBUTION AND SPECIES. One species, India only: *tachikawai* Subba Rao (1965*b*: 151), also at least three further undescribed species from India and Malaysia (BMNH).

BIOLOGY. Parasites of Pseudococcidae (Homoptera).

COMMENTS. The genus belongs to the tribe Chrysoplatygerini, subtribe Chrysoplatygerina (Tetracneminae). A key to related genera is provided by Kerrich (1978: 113–114).

NEORHOPUS Girault

(Key couplet: 56)

Neorhopus Girault, 1917*g*: 139. Type-species: *Neorhopus australicus* Girault, by original designation.

DISTRIBUTION AND SPECIES. One species, Australia only: *australicus* Girault (1917*g*: 140) (= *Neorhopus australicus aureus* Girault, 1917*g*: 140 **syn. n.**).

BIOLOGY. Parasites of Pseudococcidae (Homoptera).

COMMENTS. Very close to *Rhopus* (tribe Anagyrini, subtribe Rhopina), but can be distinguished by having a five-segmented funicle, whereas *Rhopus* has a six-segmented funicle.

NEZARHOPALUS Girault

(Key couplet: 198)

Nezarhopalus Girault, 1915*a*: 109. Type-species: *Nezarhopalus caudatus* Girault, by original designation.

DISTRIBUTION AND SPECIES. One species, Australia only: *caudatus* Girault (1915*a*: 109).

BIOLOGY. Unknown.

COMMENTS. The holotype of *caudatus* is in very poor condition and mounted on a slide (QM). A critical assessment of the validity of the genus will not be possible until freshly collected material can be carefully compared with it. The wings of the holotype cannot be located and the relative position of the apex of the hypopygium cannot be determined. These are considered to be important diagnostic characters and therefore we prefer to retain *Nezarhopalus* as valid for the present. However, the genus appears to be close to *Coccidoctonus* (tribe Microteriyini, subtribe Syrphophagina) and *caudatus* may be very close to *C. lowelli*. From the parts available for comparison these two species differ only slightly in the relative width of the scape.

OLYPUSA gen. n.

(Key couplet: 460. Figs 217–219, 379)

Type-species: *Olypusa hirsuta* sp. n. Gender: feminine.

♀. *Head.* In frontal view about one-quarter wider than long, in profile about twice as long as broad and more or less gradually and evenly rounded anteriorly. Eye with posterior margin straight with extremely short, sparse, inconspicuous setae, eye about one-third longer than broad and more or less reaching occipital margin which is very sharp. Malar space about one-half as long as eye, with sulcus absent. Frontoververtex about two-fifths head width; ocelli forming an obtuse angle, the posterior ones about equidistant from eye and occipital margins. Antennal scrobes broadly semicircular, just meeting dorsally and delimited dorsally by a more or less complete carina and reaching a little less than half way from antennal toruli to anterior ocellus; antennal torulus separated from mouth margin and from other torulus by a little more than its own length, its lower margin a little above the ventral margins of the eyes; mouth margin broadly concave. Antennal scape subcylindrical, about four or five times as long as broad and about as long as minimum width of frontoververtex; pedicel conical, about one-third as long as scape and a little shorter than first funicle segment which is clearly longer than broad; funicle segments cylindrical, shortening and broadening slightly so that sixth funicle segment is a little transverse; clava entire, apically rounded and slightly less than one-third as long as funicle; longitudinal sensillae on all flagellar segments, longest setae not more than about one-half as long as diameter of segments. Frontoververtex with shallow, raised, irregular, transverse, reticulate sculpture, this becoming finer and more irregular on lower parts of

face and on interantennal prominence; frontovertex with numerous short translucent setae, each a little shorter than the diameter of the facet, lower parts of face and interantennal prominence with fairly dense, downwardly directed pale setae. Mandible apically rounded, edentate; maxillary palpus four-segmented, the apical segment longer and larger than the other three together; labial palpus two-segmented.

Thorax. In side view robust, both mesoscutum and scutellum only very slightly convex, almost flat; metapleurum and propodeum together broadly in contact with hind coxa. In dorsal view posterior margin of pronotum broadly concave; visible part of mesoscutum slightly less than twice as broad as long with notaular lines absent, its posterior margin clearly convex; axillae meeting medially; scutellum a little longer than broad, apically rounded with an indistinct apical flange and very indistinctly carinate longitudinally in middle (this only visible if viewed in correct position and correct light); propodeum medially nearly one-third length of scutellum. Pronotum, mesoscutum and axillae with shallow, raised, squamiform-reticulate sculpture; scutellum with more longitudinally elongate and slightly deeper reticulate sculpture; propodeum with shallow, raised, reticulate sculpture; mesopleurum almost smooth with very shallow, raised, irregular, longitudinally elongate sculpture; pronotum, mesoscutum and axillae with fairly dense, short, inconspicuous dark setae, scutellum clothed in dense conspicuous white setae which become progressively longer towards apex of scutellum, propodeum on outside of spiracles with dense, short, pale setae. Forewing almost hyaline, but clearly suffused dark brown, slightly paler nearer base and with a few paler streaks or areas, wing only a little more than twice as long as broad; linea calva very narrow, closed towards hind margin by several lines of setae on dorsal surface; filum spinosum present; submarginal vein without an apical hyaline break and with parastigma a little but distinctly broader than proximal part of vein; costal cell about eight times as long as broad, with setae dorsally about as dense as in disc of wing; marginal vein about four times as long as broad; stigmal vein long and curved, about twice as long as marginal vein and subequal to postmarginal vein, a narrow naked streak extending from apex of postmarginal to apex of stigmal vein. Hindwing hyaline, about two-thirds lengths of forewing and about two and one-half times as long as broad, costal cell about seven times as long as broad, marginal setae less than one-twentieth maximum wing width. Mid tibial spur slightly shorter than mid basal tarsal segment.

Gaster. About two-thirds as long as thorax; cercal plates in basal one-third; hypopygium reaching to about four-fifths along gaster, with several long setae medially at its apex; ovipositor not exerted.

♂. Apart from genitalia and antenna very similar to female. Differs as follows. Antenna yellow with sixth funicle segment a little longer than broad. Genitalia with aedeagus spatulate, i.e. a little broadened subapically, digiti very stout, only about three times as long as broad.

COMMENTS. Belongs to the same group of genera as *Encyrtus*, *Prionomastix* and *Aethognathus* (see comments under *Anagyrodes*); separated from related genera by the combination of the solid clava in the female, relatively widely separated antennal toruli, densely hairy forewings, moderately long marginal vein, subequal postmarginal and stigmal veins, structure of scutellum, lack of apical scutellar tuft and the relatively well-advanced cercal plates (in the other genera they are generally about half way along gaster or in posterior half).

Olypusa hirsuta sp. n.

(Figs 217–219, 379)

♀. Length: 1.82–2.24 mm (holotype, 2.14 mm).

Colour. Head, thorax and gaster black or very dark brown except a very narrow area between eye and occipital margin dorsally, on occiput immediately below this and a small quadrate area on each side of pronotum which are white; legs dark brown except knees, fore and mid tarsi, apex and base of mid femur and tibia, apex of mid tibia, mid tibial spur and basal tarsal segment which are yellowish white to yellow-orange, mid tibial spur sometimes dark brown; forewing generally suffused dark brown except proximal half of basal cell, costal cell, a small area at apex of venation and an indistinct longitudinal streak from linea calva which is more or less hyaline (Fig. 217).

Head. Relative measurements (holotype): head length 44, head width (facial view) 54, head width (side view) 24, minimum frontovertex width 22.5, malar space 15, eye length 30, eye width 23, POL 12.5, OOL 3, scape length 23, scape width 5, proportions of antennal segments as in Fig. 219, head in facial view as in Fig. 218.

Thorax. Relative measurements (holotype): forewing length 126, width 58, venation and base of forewing as in Fig. 217; hindwing length 91, hindwing width 33.

♂. Similar to female except antenna which is yellowish, foretibia which may be completely yellowish, and genitalia (see generic description). Antenna as in Fig. 379.

DISTRIBUTION. Papua New Guinea.

BIOLOGY. Unknown.

MATERIAL EXAMINED

Holotype ♀, **Papua New Guinea**: Wau, 1100–1200 m, vi.1968 (*N. L. H. Krauss*) (BPBM).
Paratypes. **Papua New Guinea**, 1 ♀, Torricelli Mts, Mobitei, 750 m, 1–15.iv.1959 (*J. W. Brandt*) [Specimen lacking head]; 1 ♂, Kokoda-Pitoki, 400 m, 23.iii.1956 (*J. L. Gressitt*); 1 ♀, New Ireland, SW, Gilingil Plantation, 2 m, 5.vii.1956 (*J. L. Gressitt*) (specimen lacking head); 1 ♂, New Britain, Warongoi Valley, Gazelle Peninsula, 100 m, 25.v.1956 (*J. L. Gressitt*) (specimen lacking gaster) (BPBM).

OOENCYRTUS Ashmead

(Key couplets: 91, 260, 283, 313, 339, 381, 393, 431, 438, 494, 514.

Figs 152, 177, 181, 182, 246, 381)

Ooencyrtus Ashmead, 1900b: 381. Type-species: *Encyrtus clisiocampae* Ashmead, by original designation.
Echthrodryinus Perkins, 1906: 252. Type-species: *Echthrodryinus destructor* Perkins, by monotypy. **Syn. n.**

Schedius Howard, 1910: 2. Type-species: *Schedius kuvanae* Howard, by original designation.

Tetracnemella Girault, 1915a: 170. Type-species: *Tetracnemella australiensis* Girault, by original designation. **Syn. n.**

Xesmatia Timberlake, 1920: 424. Type-species: *Xesmatia flavipes* Timberlake, by original designation. **Syn. n.**

Pseudolitomastix Risbec, 1954: 1068. Type-species: *Litomastix creona* Risbec, by original designation.

DISTRIBUTION AND SPECIES. About one-hundred species, cosmopolitan; 37 from review area: *alboantennatus* (Subba Rao, 1971: 222) (**comb. n.** from *Pentalitomastix*) (Java), *australiensis* (Girault, 1915a: 170) (**comb. n.** from *Tetracnemella*) (Australia), *batocerae* Ferrière (1936: 333) (Malaysia), *bicolor* Girault (1915a: 78) (Australia), *cochereaui* Prinsloo & Annecke (1978a: 41) (New Caledonia), *corbetti* Ferrière (1931: 284) (Malaysia), *crassulus* Prinsloo & Annecke (1978a: 42) (Samoa), *destructor* (Perkins, 1906: 253) (**comb. n.** from *Echthrodryinus*) (Australia), *erionotae* Ferrière (1931: 284) (India, Malaysia, Java, Mariana Is., Hawaiian Is.), *euxoae* (Girault, 1927a: 2) (**comb. n.** from *Schedius*) (Australia), *ferrierei* Shafee, Alam & Agarwal (1975: 97) (India), *flavipes* (Timberlake, 1920: 425) (**comb. n.** from *Xesmatia*) (Hawaiian Is.), *guamensis* Fullaway (1946: 205) (Mariana Is., Hawaiian Is.), *hyalinipennis* (Dodd, 1917: 354) (**comb. n.** from *Tetracnemella*) (Australia), *inconspicuus* (Girault, 1915a: 141) (**comb. n.** from *Coccidoxenus*) (Australia), *javanicus* Mercet (1922a: 152) (Java), *johnsoni* (Howard, 1898a: 18) (Hawaiian Is.), *lacteiclavus* Girault (1932b: 1) (Australia), *larvarum* (Girault, 1919b: 58) (**comb. n.** from *Paracopidosomopsis*) (Java), *leucocerus* Mercet (1922a: 150) (Java), *major* Ferrière (1931: 285) (Java), *malayensis* Ferrière (1931: 282) (India, Malaysia, Indonesia, Papua New Guinea), *metallicus* Girault (1914a: 37) (Australia), *ovidivorus* (Girault, 1925a: 2) (**comb. n.** from *Echthrodryinus*) (Australia), *pacificus* Waterston (1915: 307) (Fiji), *pallidipes* (Ashmead, 1904a: 15) (**comb. n.** from *Aphidencyrtus*) (Philippines), *papilionidis* (Girault, 1932c: 3) (**comb. n.** from *Stenoteropsis*) (Australia), *papilionis* Ashmead (1905a: 4) (Pakistan, India, Philippines), *phongi* Trjapitzin, Myartseva & Kostjukov (1977: 671) (Vietnam), *podontiae* Gahan (1922: 51) (Java), *segestes* Trjapitzin (1965: 320) (Indonesia), *shakespearei* (Girault, 1923a: 48) (**comb. n.** from *Coccidoxenus*) (Australia), *sphingidarum* Timberlake (1941: 223) (Marquesas Is.), *submetallicus* (Howard; Noyes, 1979: 160) (Hawaiian Is.), *swezeyi* Fullaway (1946: 206) (Mariana Is.), *tricolor* (Girault, 1915a: 140) (**comb. n.** from *Coccidoxenus*) (Australia), and *xanthogaster* (Girault, 1915a: 150) (**comb. n.** from *Echthrodryinus*) (Australia), also much undetermined material from throughout the region (BMNH, BPBM, CNC, GC).

REFERENCE. Key to Indo-Malayan species: Trjapitzin et al. (1977: 672–674).

BIOLOGY. Parasites of eggs of various insects, notably Lepidoptera and Heteroptera, and of

spiders (Araneida). Several species are also hyperparasites of other Hymenoptera (Dryinidae and Braconidae) parasitising Lepidoptera and Auchenorrhyncha (Homoptera). One group (*guamensis*-group) of species are parasites of Aphididae (Homoptera) and puparia of Syrphidae (Diptera).

COMMENTS. The species previously included in *Echthrodryinus* (see Gordh & Trjapitzin, 1978) almost certainly represent a polyphyletic group since they appear to be more closely related, morphologically, to widely separated species of *Ooencyrtus* than they do to each other, e.g. *Ooencyrtus bucculatricis* (Howard) (**comb. n.**) is more closely related to *Ooencyrtus johnsoni* (Howard) than it is to *destructor* (the type-species of *Echthrodryinus*). Thus in our view the change from egg parasitism to larval parasitism or hyperparasitism must have occurred more than once and probably via different routes. Therefore we can find no reason for retaining *Echthrodryinus* as a distinct genus whose type-species or other included species cannot be reliably separated from species of *Ooencyrtus* other than by an apparent difference in biology.

The *guamensis*-group is an apparently monophyletic group of species found in South America (see Noyes, 1980: 194), Africa, India and Mariana Is. which parasitise syrphid puparia (and also possibly aphids). The species of this group can be distinguished from other species of *Ooencyrtus* by being slightly larger and the colour of the head and thorax always being black or dark brown with a very slight blue or green sheen, the mesoscutum clothed in very conspicuous white or translucent setae and the marginal vein of the forewing always being punctiform and the stigmal vein relatively long. For the present, we prefer to leave these species in *Ooencyrtus* than propose a new genus to accommodate them.

One group consists of species (*bicolor*, *lacteiclavus* and *metallicus*) which are parasites of spiders' eggs. For the present we are leaving these in *Ooencyrtus* although it may be considered that they belong to a genus apart. They can be distinguished from other species of *Ooencyrtus* by the infusate forewings and largely pale brown or orange-brown thorax instead of the usual metallic or dark brown colour typical of *Ooencyrtus*. They differ also in general body shape, especially that of the head.

It is possible that *Scotteus* Masi (1917b) is a synonym of *Ooencyrtus*. The holotype of *ochroleucus* has been examined (BMNH) but unfortunately the body is missing. However, the remaining parts (forewing, antenna and legs) and Masi's description indicate that it may be a species of *Ooencyrtus* with an obliquely truncate clava (species with an obliquely truncate clava are known to occur in the Neotropics).

The genus is placed in the tribe Microteriyini, subtribe Ooencyrtina (Encyrtinae) and can be separated from other closely related genera (including *Trichomasthus* and *Fulgoridicida*) by the characters given in the key.

OVALOENCYRTUS gen. n.

(Key couplets: 133, 470. Figs 67, 68, 225, 382–384)

Type-species: *Ovaloencyrtus fijiensis* sp. n. Gender: masculine.

♀. *Head*. In frontal view slightly broader than long, in profile slightly less than twice as long as broad and anteriorly evenly rounded to top of antennal scrobes, below this almost straight to mouth margin. Eye with moderately conspicuous hairs, each clearly longer than the diameter of a facet, posterior margin of eye imperceptibly concave, eye about one-quarter longer than broad and reaching occipital margin which is sharp. Malar space nearly half as long as eye, with sulcus present. Frontovortex about one-quarter head width; ocelli forming a slightly acute angle, the posterior ones nearly touching eye and separated from occipital margin by about their own major diameters. Antennal scrobes fairly long and narrow, more or less meeting dorsally and reaching about half way from antennal toruli to anterior ocellus, interantennal prominence dorsally acute; antennal torulus separated from mouth margin by a little less than its own length and from other torulus by about its own length, its dorsal margin about level with ventral margins of eyes; clypeus fairly broadly and deeply excised medially. Antennal scape clearly longer than width of frontovortex and broadened and flattened, about three times as long as broad; pedicel conical, about one-third length of scape and clearly longer than any of the funicle segments which are cylindrical and

slightly broadening distally, the first four of which are a little longer than broad or quadrate, the fifth and sixth transverse; clava three-segmented, a little longer than funicle, with a strongly oblique apical truncation with the sutures strongly convergent towards base ventrally; longitudinal sensillae on all flagellar segments except first two, longest setae about as long as diameter of first segment. Frontovortex above antennal scrobes almost completely smooth except for the shallow piliferous punctures, top of scrobes and between scrobes and eyes with shallow, raised, rugose-reticulate to squamiform-reticulate sculpture, interantennal prominence and genae with squamiform-reticulate sculpture, piliferous punctures on lower parts of face deeper than on frontovortex; setae on frontovortex sparse but conspicuous, each longer than diameter of an ocellus. Mandible with two very small teeth and a very broad truncation; maxillary palpus four-segmented, labial palpus three-segmented.

Thorax. In side view moderately robust with mesoscutum and scutellum only slightly convex, almost flat; propodeum and metapleurum together quite widely separated from hind coxa by the posterior margin of the mesopleurum which is quite broadly in contact with basal segment of gaster. In dorsal view pronotum broadly concave but not strongly so; visible part of mesoscutum about four-fifths broader than long with notaular lines absent and posterior margin convex and slightly projecting above axillae and thus these appear broadly separated; axillae more or less meeting; scutellum about as long as mesoscutum and a little broader than long, with apex rounded; propodeum medially about one-fifth length of scutellum. Mesoscutum and axillae with shallow, raised, squamiform-reticulate sculpture, scutellum more or less entirely smooth and polished but in anterior one-third or so with extremely shallow reticulate sculpture; mesopleurum smooth and shiny but bordered posteriorly, ventrally and anteriorly by some shallow, irregular, reticulate to rugose sculpture; propodeum with some fairly deep, raised irregular sculpture medially and laterally. Forewing lightly infuscate, pale brown in middle beneath venation and near base, nearly three times as long as broad; linea calva not interrupted or closed; filum spinosum present; submarginal vein with an indistinct apical hyaline break, parastigma not swollen; costal cell about 10 times as long as broad, with a single line of setae dorsally in apical one-third; marginal vein about four times as long as broad, about twice as long as postmarginal and a little shorter than stigmal. Hindwing about three-quarters as long as forewing, about five times as long as broad, with marginal setae about one-third as long as maximum wing width. Mid tibial spur shorter than basal mid tarsal segment.

Gaster. Shorter than thorax; cercal plates in anterior half; hypopygium reaching to about four-fifths along gaster; last tergite about two-thirds as long as mid tibia, paratergites absent; ovipositor a little shorter than mid tibia, gonostyli free, about one-quarter as long as ovipositor.

♂. Unknown.

COMMENTS. Closely related to *Paratetralophidea* from which it can be separated by the characters given in the key. Also probably related to *Xenoencyrtus* and *Ooencyrtus* (tribe Microteriyini, Ooencyrtina) and separated from both by the very long, strongly obliquely truncate clava, relatively long marginal and stigmal veins of the forewing and sharp occipital margin.

Ovaloencyrtus fijiensis sp. n.

(Figs 67, 68, 225, 382–384)

♀. Length: 0.95–1.13 mm (holotype, 1.13 mm).

Colour. Head strongly shining metallic green, purple or blue, mesoscutum shining purple, scutellum strongly shining deep blue or green with strong purple reflections; propodeum and mesopleurum dark brown; antenna very dark brown, almost black; all coxae, fore femur, fore tibia and tarsus to a less extent, dark brown, remainder of legs orange-brown; gaster dark brown, basally orange-brown; forewing generally suffused pale brownish, darker in middle across wing from apical one-third of venation, proximal part of basal cell, except extreme base, more or less hyaline (Fig. 68).

Head. Relative measurements (holotype): head length 64, head width (facial view) 75, head width (side view) 35, minimum width of frontovortex 20, POL 8, OOL 1.5, malar space 21, length of eye 46, width of eye 38, scape length 45, maximum scape width 14, other proportions of antenna as in Fig. 67, mandible as in Fig. 225. There is a little variation in the relative width of the frontovortex; in smaller specimens it is slightly wider and thus correspondingly the eyes are a little smaller.

Thorax. Relative measurements (holotype): forewing length 174, width 65; hindwing length 123, width 26; base of forewing as in Fig. 68, forewing venation as in Fig. 382.

Gaster. Relative lengths (paratype): ovipositor 80, last tergite 60, [mid tibia 88]; genitalia as in Fig. 383, hypopygium as in Fig. 384.

♂. Unknown.

DISTRIBUTION. Fiji.

BIOLOGY. Unknown.

MATERIAL EXAMINED

Holotype ♀, **Fiji**: Viti Levu, Nausori Highlands, 500–700 m, xi.1976 (*N. L. H. Krauss*) (BPBM).

Paratypes. **Fiji**: 1 ♀, same data as holotype, 26.iii.1970; 1 ♀, Ovalau, Levuka, 0–200 m, xii.1969 (*N. L. H. Krauss*); 1 ♀, Lami, 20–200 m, iii.1976 (*N. L. H. Krauss*); 1 ♀, Lau, Lakomba, 3.ix.1924 (*E. H. Bryan Jr*) (BPBM, BMNH).

OVIDOENCYRTUS Girault

(Key couplet: 492)

Ovidoencyrtus Girault, 1924a: 7. Type-species: *Ovidoencyrtus pallidipes* Girault, by monotypy.

DISTRIBUTION AND SPECIES. One species, Australia only: *pallidipes* Girault (1924a: 7).

BIOLOGY. Parasites of eggs of Reduviidae (Heteroptera).

COMMENTS. We are unable to place the genus according to Trjapitzin's (1973b) classification of the Encyrtinae.

PAKSIMMONDSIUS Ahmad & Ghani

(Key couplet: 134. Fig. 73)

Paksimmondsius Ahmad & Ghani, 1974: 391. Type-species: *Paksimmondsius pakistanensis* Ahmad & Ghani, by original designation.

DISTRIBUTION AND SPECIES. One species, Pakistan only: *pakistanensis* Ahmad & Ghani (1974: 392).

BIOLOGY. Parasites of Kermesidae (Homoptera).

COMMENTS. *Paksimmondsius* appears to be related to *Leurocerus* and *Zozoros* and can be separated from these genera by the characters given in the key (see also comments under *Leurocerus* and *Zozoros*).

PAPUNA gen. n.

(Key couplet: 346. Figs 190, 385–389)

Type-species: *Papuna nemis* sp. n. Gender: feminine.

♀. *Head*. In facial view about one-quarter broader than long, in profile about one-half longer than broad and gradually and evenly curved dorsally, most strongly curved about level with top of scrobes, below this point almost straight. Eye with posterior margin more or less straight, only a little longer than broad, conspicuously hairy and overreaching occipital margin which is more or less rounded, at least not sharp. Malar space about half length of eye, with sulcus present. Frontoververtex a little less than one-third head width; ocelli fairly large, forming an acute angle which is almost an equilateral triangle, the posterior ocellus separated from occipital margin by slightly less than its own diameter and considerably closer to the eye margin. Antennal scrobes moderately deep and elongate, meeting dorsally and reaching about two-thirds from antennal toruli to anterior ocellus; antennal torulus separated from mouth margin by about three-quarters its own length and from other torulus by about one and one-half times its own length, its dorsal margin about level with lowest margin of eye, clypeal margin shallowly excised between toruli. Antennal scape clearly longer than minimum width of frontoververtex, slightly flattened and broadened, slightly more than three times as long as broad; pedicel conical, slightly more than one-third length of scape and clearly much longer than any of the funicle segments which are all transverse and nearly equal in length but become much broader apically; clava three-segmented with a strong oblique, apical truncation and much broader than and a little longer than funicle, the sutures strongly converging; longitudinal sensillae on all segments of flagellum; longest setae about as long as diameter of first funicle segment. Frontoververtex

with very shallow, raised reticulate sculpture of small mesh, more squamiform-reticulate between eyes and antennal toruli and lower parts of face where it also becomes more longitudinally elongate; frontovertex and lower parts of face clothed in fairly dense, conspicuous setae, each about as long as the diameter of an ocellus. Mandible with two teeth and a truncation or obscurely tridentate; maxillary palpus four-segmented, labial palpus three-segmented.

Thorax. In side view with mesoscutum and scutellum quite flat, the metapleurum together with the propodeum quite broadly in contact with hind coxa. In dorsal view posterior margin of pronotum quite strongly concave and slightly angled medially; visible part of mesoscutum about one-half broader than long, notaular lines absent, its posterior margin angled outwards medially; axillae meeting; scutellum a little shorter than mesoscutum and a little broader than long, its apex rounded; propodeum medially about one-eighth as long as scutellum, laterally with fairly dense setae almost completely surrounding the spiracle, except posteriorly. Dorsum of thorax with sculpture similar to frontovertex, but perhaps of slightly larger mesh, mesopleurum almost smooth but with some very shallow, irregular sculpture; propodeum medially with numerous, shallow, incomplete carinae, laterally with irregular, raised, rugose sculpture; dorsum of thorax with setae of similar length, colour and density to those on frontovertex. Forewing more or less hyaline but very faintly suffused brownish, nearly three times as long as broad; linea calva not interrupted or closed; filum spinosum present; submarginal vein with an apical hyaline break, parastigma very slightly and conspicuously swollen; costal cell about 15 times as long as broad, with a single line of setae dorsally in its apical half; marginal vein about six times as long as broad, subequal to stigmal, both a little shorter than postmarginal. Hindwing about two-thirds as long as forewing, about four times as long as broad, with marginal setae about one-fifth as long as maximum wing width. Mid tibial spur slightly shorter than basal tarsal segment.

Gaster. Without exerted part of ovipositor about as long as thorax, exerted part of ovipositor about one-third as long as gaster; cercal plates in anterior half of gaster; hypopygium with apex a little more than half way along gaster; last tergite produced apically, very pointed, slightly longer than mid tibia; ovipositor about twice as long as mid tibia or gonostyli; gonostyli free.

♂. Unknown.

COMMENTS. Placement of this genus according to Trjapitzin's classification of the Encyrtinae is difficult. The structure of the antenna is very similar to that found in the Tyndarichina (Cheiloneurini, see Trjapitzin & Gordh, 1980), but differs from these in the structure of the mandible, wing venation and the mesopleurum not being posteriorly enlarged. It is most probable that this genus is related to *Pseudencyrtus* (Microteriyini, Pseudencyrtina), having a similar structure of the gaster (e.g. elongate last tergite), thorax, mandible and head. It differs from *Pseudencyrtus* in forewing venation (e.g. postmarginal vein longer than stigmal, smaller angle between stigmal and postmarginal veins), narrower hindwing (in *Pseudencyrtus* it is not much more than three times as long as broad), narrower frontovertex (*Pseudencyrtus* has the frontovertex more than one-third head width) and antenna.

***Papuna nemis* sp. n.**

(Figs 190, 385–389)

♀. Length (excluding ovipositor): 1.98–2.03 mm (holotype, 2.03 mm).

Colour. Frontovertex deep metallic blue-green with purple reflections around eyes, below top of toruli more green with blue or purple reflections, antennal scrobes above toruli coppery; antenna with scape yellow, pedicel apically testaceous, basal part of pedicel and flagellum dark brown; mesoscutum dull shining dark blue with purple reflections, axillae brownish purple with brassy reflections; scutellum dull shining blue-green with apex distinctly more shiny green with brassy reflections; mesopleurum dark chestnut-brown; legs with all coxae and femora dark brown, fore femur apically yellowish, mid femur with a pale sub-basal ring, all tibiae and tarsi yellow; propodeum and gaster (including ovipositor sheaths) dark brown, the gaster with strong brassy purple reflections; apex of ovipositor sheaths yellowish.

Head. Head in facial view as in Fig. 387, mandible as in Fig. 388. Relative measurements (holotype): head length 85, head width (facial view) 103, head width (side view) 52, minimum frontovertex width 30, malar space 34, eye length 61, eye width 54, POL 13, OOL 2, scape length 41, scape width 13, proportions of antenna as in Fig. 385.

Thorax. Relative measurements (holotype): forewing length 278, width 100, base of forewing as in Fig. 386, venation as in Fig. 190; hindwing length 175, width 45.

Gaster. Relative lengths (paratype): last tergite 60, ovipositor 118, [mid tibia 53]; genitalia as in Fig. 389.
♂. Unknown.

DISTRIBUTION. Papua New Guinea.

BIOLOGY. Unknown.

MATERIAL EXAMINED

Holotype ♀, Papua New Guinea: Morobe Province, Lasanga I., x.1979 (*J. H. Martin*) (BMNH).

Paratype. Papua New Guinea: 1 ♀, Morobe Province, Buso Forest, x.1979 (*J. H. Martin*) (BMNH).

PARABLASTOTHRIX Mercet

(Key couplet: 15)

Parablastothrix Mercet, 1917d: 538. Type-species: *Parablastothrix vespertinus* Mercet, by monotypy.

DISTRIBUTION AND SPECIES. Fourteen species, cosmopolitan; three species from review area: *magnioculus* (Girault, 1923a: 47) (**comb. n.** from *Schedius*) (= *Paracaenocercus albifemur* Girault, 1922b: 103 **syn. n.**) (Australia), *nepticulae* Hedqvist (1976: 50) (Sri Lanka) and *unicinctipes* (Girault, 1915a: 111) (**comb. n.** from *Schedius*) (Australia), also further undetermined material from Bismark Archipelago, Solomon Is. and Australia (BMNH, BPBM, QM, ANIC).

REFERENCE. Key to Holarctic species: Loginovskaya (1981: 160–162).

BIOLOGY. Parasites of larvae of Lyonetiidae and Nepticulidae (Lepidoptera).

COMMENTS. Trjapitzin & Gordh (1978b) erected the new subtribe Parablastothrichina within the tribe Copidosomatini (Encyrtinae) to accommodate *Parablastothrix* and *Calometopia*. However, we think that the genera of this subtribe (including also *Mashhoodiella*) are morphologically closer to the Aphycina (tribe Aphycini) than they are to the Copidosomatini.

PARABLATTICIDA Girault

(Key couplets: 42, 175, 195, 212. Figs 390–395)

Parablatticida Girault, 1915a: 117. Type-species: *Parablatticida pachyscapa* Girault, by original designation.

Holanusia Girault, 1915a: 162. Type-species: *Holanusia convexus* Girault, by original designation. **Syn. n.**

Symphycus Masi, 1917b: 149. Type-species: *Symphycus aphycoides* Masi, by monotypy. **Syn. n.**

Geniaspidius Masi, 1917b: 155. Type-species: *Geniaspidius viduus* Masi, by monotypy. **Syn. n.**

Amaurilyma Graham, 1958: 153. Type-species: *Encyrtus brevicornis* Dalman, by original designation.

Syn. n.

Desobius Noyes, 1980: 192. Type-species: *Desobius convexus* Noyes, by original designation. **Syn. n.**

DISTRIBUTION AND SPECIES. Seven species, Neotropical, Palaearctic, Afrotropical, Oriental and Australasian; one from review area: *pachyscapa* Girault (1915a: 117) (= *Holanusia convexus* Girault, 1915a: 162 **syn. n.**) (Australia), also much undetermined material, including many undescribed species, from India and Taiwan to Samoa and Australia (BMNH, BPBM, ANIC, HC).

BIOLOGY. Unknown.

COMMENTS. Examination of material from throughout the region has shown that the species previously placed in *Desobius* fall within our concept of the range of variation within *Parablatticida*. We have found that differences in sculpture of the mesoscutum and relative position of the hypopygium are not consistent and therefore regard *Desobius* as a synonym of *Parablatticida*.

The holotype male of *Geniaspidius viduus* Masi (BMNH) belongs to *Parablatticida* (**comb. n.**) and to the same species-group as *trinidadensis* (**nom. n.** for *convexus* Noyes, 1980 nec Girault, 1915), characterised by the striate-reticulate sculpture of the mesoscutum and generally smaller size.

We have examined the four syntypes of *Symphycus aphycoides* Masi (BMNH, ZMUC, MCSN). The female from ZMUC is here designated LECTOTYPE and has been so labelled. It is in several fragments glued on a card rectangle but is more or less complete. It falls within our concepts of the limits of *Parablatticida* and therefore we believe that the two genera are synonymous. The single male syntype is not congeneric.

Parablatticida brevicornis (Dalman) (**comb. n.**) is very close to *pachyscaptha* Girault and differs only very slightly in the relative width of the scape and frontovertex. More detailed study may show that these differences fall within the range of variation of *brevicornis*.

We are unable to place the genus, although it may be related to *Exoristobia* or *Phauloencyrtus*.

PARACERAPTRCERUS Girault

(Key couplet: 113)

Paraceraptrocerus Girault, 1920c: 184. Type-species: *Paraceraptrocerus africanus* Girault, by original designation.

DISTRIBUTION AND SPECIES. Fourteen species, Neotropical, West Palaearctic, Afrotropical, Oriental; two species from review area: *brevicaudatus* (Subba Rao, 1965a: 74) (India) and *italicus* (Masi, 1917a: 80) (India).

REFERENCE. Revision: Annecke (1967: 130–156).

BIOLOGY. Parasites of Coccidae (Homoptera).

COMMENTS. The genus is very close to *Anicetus* (tribe Cerapterocerini) and possibly should be considered synonymous. Annecke (1967: 100–101) provides a key to distinguish this genus from its relatives.

PARACHALCERINYS Girault

(Key couplet: 497)

Parachalcerinys Girault, 1925b: 97. Type-species: *Parachalcerinys nonaericornis* Girault, by monotypy.

DISTRIBUTION AND SPECIES. Two species, both Australian: *coccidoxenoides* Girault (1926c: 130) and *nonaericornis* Girault (1925b: 97).

BIOLOGY. Unknown.

COMMENTS. Girault (1926c: 130) stated that the type-species of *Parachalcerinys* was *coccidoxenoides* but since the description of *Parachalcerinys nonaericornis* was published the previous year, *nonaericornis* must be taken as the type-species.

The two species included here may belong to different genera; *coccidoxenoides* possibly to *Australia* (see comments under *Australia*) and *nonaericornis* to *Psyllaephagus*. However, until fresh material can be carefully compared with the types of the two included species we prefer to retain them in the present combination and thus treat *Parachalcerinys* as a valid genus.

PARACLADELLA Girault

(Key couplets: 422, 429)

Paracladella Girault, 1920d: 142. Type-species: *Paracladella globosa* Girault, by monotypy.

DISTRIBUTION AND SPECIES. Two species, Australia only: *giorgionei* Girault (1932a: 4) and *globosa* Girault (1920d: 142).

BIOLOGY. Unknown.

COMMENTS. The holotype male of *globosa* (QM) is in extremely poor condition, but may be the male of *giorgionei*.

Paracladella belongs to the same group of genera as *Anagyrodes* (see comments under *Anagyrodes*) and is probably most closely related to *Neocladia* (tribe Neocladiini). It can be separated from related genera by having a mandible with a single long tooth (which may have a short subapical second tooth), a solid clava and forewing with a punctiform marginal vein.

PARACLAUSENIA Hayat

(Key couplets: 265, 502. Figs 151, 396, 397)

Paraclausenia Hayat, 1980: 637. Type-species: *Paraclausenia herbicola* Hayat, by original designation.

DISTRIBUTION AND SPECIES. One described species, India only: *herbicola* Hayat (1980: 639), also further undetermined material, which may include an undescribed species, from India and S. China (BMNH, BPBM).

BIOLOGY. Unknown.

COMMENTS. This genus belongs to the tribe Charitopidini (Tetracneminae).

PARAENASOMYIA Girault

(Key couplets: 302, 342, 433, 456. Fig. 178)

Paraenasomyia Girault, 1915a: 110. Type-species: *Paraenasomyia orro* Girault, by monotypy.

DISTRIBUTION AND SPECIES. Three species, Australia only: *australiensis* (Girault, 1914b: 59) (**comb. n.** from *Copidosoma*) (= *Cerchysius bellulus* Girault, 1915a: 84), *johnsoni* Girault (1922f: 1) and *orro* Girault (1915a: 110).

BIOLOGY. Parasites of galls of Cecidomyiidae (Diptera).

COMMENTS. Girault (1917e: 95) synonymised *bellulus* and *australiensis*. Comparison of the descriptions of both species indicates that he must have inadvertently described the same specimen twice under two different names.

Its biology, wing venation and general morphology indicate that the genus is probably related to *Pseudencyrtus* (Microteriyini, Pseudencyrtina).

PARALEPTOMASTIX Girault

(Key couplet: 459)

Paraleptomastix Girault, 1915a: 168. Type-species: *Paraleptomastix thoreauini* Girault, by original designation.

DISTRIBUTION AND SPECIES. One species Australia only: *thoreauini* Girault (1915a: 168).

BIOLOGY. Unknown.

COMMENTS. Belongs to the same group of genera as *Anagyrodes* (see comments under *Anagyrodes*) and is probably most closely related to *Neocladia* (tribe Neocladiini). It can be separated from related genera by having a mandible with a long single tooth (possibly with a smaller subapical tooth), a three-segmented clava, forewing with a relatively long marginal vein and hypopygium reaching the apex of the gaster.

PARALITOMASTIX Mercet

(Key couplet: 498)

Paralitomastix Mercet, 1921: 438. Type-species: *Encyrtus varicornis* Nees, by original designation.

DISTRIBUTION AND SPECIES. Sixteen species, cosmopolitan; three from review area: *bicoloricornis* (Girault, 1915a: 104) (**comb. n.** from *Coccidencyrtus*) (Australia), *ipswichia* (Girault,

1923d: 2) (**comb. n.** from *Coccidencyrtus*) (Australia) and *varicornis* (Nees; Mercet, 1921: 439) (Pakistan, India), also some undetermined material from Australia (BMNH).

BIOLOGY. Polyembryonic parasites of larvae of Pyralidae and Gelechiidae (Lepidoptera).

COMMENTS. Placed in the tribe Copidosomatini, subtribe Copidosomatina (Encyrtinae) and should very probably be considered synonymous with *Copidosoma*. The genus can be distinguished from *Copidosoma* solely on the bicolorous antennal flagellum since several species near *Copidosoma koehleri* Blanchard have sculpture on the scutellum similar to those species placed in *Paralitomastix* (a character sometimes used to separate the two genera).

PARANATHRIX Myartseva

(Key couplets: 145, 227, 270)

Paranathrix Myartseva, 1980: 722. Type-species: *Anathrix acanthococci* Myartseva, by original designation.

DISTRIBUTION AND SPECIES. Two species, Palaearctic, Oriental and Australasian; one from review area: *thailandicus* (Myartseva, 1979: 1746) (Thailand), also much undetermined material, including several undescribed species, from Bangladesh to the Solomon Is. and Australia (BMNH, BPBM, CNC).

BIOLOGY. Parasites of Pseudococcidae (Homoptera).

COMMENTS. The species listed as *Dinocarsis* sp. by Tandon & Srivastava (1980) probably belongs to this genus (Subba Rao, pers. comm.).

Paranathrix belongs in the tribe Anagryini, subtribe Anagryina (Tetracneminae) and can be separated from related genera by the characters given in the key, in particular the pattern of silvery setae on the scutellum.

PARAPHAENODISCUS Girault

(Key couplets: 92, 136, 380)

Paraphaenodiscus Girault, 1915a: 93. Type-species: *Paraphaenodiscus verus* Girault, by original designation.

DISTRIBUTION AND SPECIES. Nine species, Afrotropical, Oriental and Australasian; three from review area, all Australian: *parus* (Girault, 1915a: 93) (**comb. n.** from *Encyrtus*), *verus* Girault (1915a: 93) and *wundti* (Girault, 1915a: 92), also two further, undescribed, species from India and Malaysia (BMNH).

REFERENCE. Revision of southern African species: Prinsloo (1976a); Prinsloo & Myndardt (1982).

BIOLOGY. Parasites of Coccidae (Homoptera).

COMMENTS. The genus is near *Microterys* (Microteryini, subtribe Microteryina) and can be separated by the characters given in the key, in particular the presence of an apical flange on the scutellum which is absent in *Microterys* (see Prinsloo, 1976a: 161).

PARAPHYCUS Girault

(Key couplets: 166, 285)

Paraphycus Girault, 1915a: 97. Type-species: *Paraphycus abnormiscapus* Girault, by original designation.

DISTRIBUTION AND SPECIES. One species, Australia only: *abnormiscapus* Girault (1915a: 97).

BIOLOGY. Unknown.

COMMENTS. The genus is the type-genus of the subtribe Paraphycina Hoffer, 1955 (tribe

Aphycini). However, this is based on a misidentification of the genus by Mercet (1921: 232) who incorrectly included the species *flavovarius* in *Paraphycus*. This species has since been transferred to *Xenaphycus* Trjapitzin.

The systematic position of *Paraphycus* cannot be accurately ascertained since the holotype female of *abnormiscapus* is lacking its head. The parts that remain suggest that it quite possibly may belong in the tribe Aphycini, but doubtfully to the subtribe Paraphycina as understood at present. The genus should be easily recognisable from the parts that remain and Girault's description.

PARARHOPELLA Girault

(Key couplet: 71)

Pararhopella Girault, 1923c: 144. Type-species: *Metalonella longfellowi* Girault, by original designation.

DISTRIBUTION AND SPECIES. Two species, both Australian: *longfellowi* (Girault, 1915a: 77) and *maculatipes* Girault (1923c: 144); possibly one further species from Australia (BMNH).

BIOLOGY. Unknown.

COMMENTS. The genus is close to *Mesorhopella* Girault (see comments under *Mesorhopella*).

PARASCHEDIUS Mercet

(Key couplets: 259, 311. Figs 180, 398, 399)

Paraschedius Mercet, 1925b: 328. Type-species: *Paraschedius ductor* Mercet, by original designation.

DISTRIBUTION AND SPECIES. Four species, Palearctic; two undescribed species from India and Java (BMNH, BPBM).

BIOLOGY. Parasites of Diaspididae (Homoptera).

COMMENTS. *Paraschedius* can probably best be placed in the tribe Habrolepidini, subtribe Comperiellina (Encyrtinae).

PARASTENOTERYS Girault

(Key couplet: 466)

Parastenoterys Girault, 1915a: 165. Type-species: *Parastenoterys punctatus* Girault, by original designation.

DISTRIBUTION AND SPECIES. One species, Australia only: *punctatus* Girault (1915a: 165).

BIOLOGY. Unknown.

COMMENTS. The genus belongs to the same group as *Rhyidothorax*, *Tachinaephagus* and possibly *Hexencyrtus* which could probably be accommodated within the subtribe Coenocercina of the Bothriothoracini (Encyrtinae). This group can be characterised by the normally relatively long propodeum and forewing with a fairly long marginal vein, stigmal vein and postmarginal vein, the stigmal vein usually fairly straight and forming an angle of less than 45° with the postmarginal. The hypopygium often reaches the apex of the gaster. *Parastenoterys* can easily be recognised because of the characteristic sculpture of the mesopleurum, the extremely elongate, relatively heavily sculptured propodeum and infusate forewings.

PARATETRACNEMOIDEA Girault

(Key couplet: 280. Figs 170, 171)

Paratetracnemoidea Girault, 1915a: 166. Type-species: *Paratetracnemoidea breviventris* Girault, by original designation.

Rhinoencyrtus Mercet, 1918: 234. Type-species: *Rhinoencyrtus malenotti* Mercet, by monotypy. **Syn. n.**

INCLUDED SPECIES. Two species, Palaearctic, Afrotropical, Oriental, Australasian; one species from review area: *breviventris* Girault (1915a: 166) (Australia), also undetermined material from India and Vietnam (BMNH, BPBM).

BIOLOGY. Unknown.

COMMENTS. Trjapitzin (1973a) incorrectly places the genus in the Tetracneminae as type-genus of the tribe Rhinoencyrtini. Examination of material by phase-contrast shows the absence of paratergites and also that the ovipositor structure is similar to that found in genera of the Copidosomatini (Encyrtinae). Furthermore, the venation and arrangement of the sensillae at the apex of the stigmal vein suggest an affinity with the Copidosomatini. General body shape and morphology is also not unsimilar to *Cowperia* (Bothriothoracini) and it may be that the present genus shows an unsuspected link between these two tribes.

PARATETRALOPHIDEA Girault

(Key couplets: 133, 463. Figs 69–71)

Paratetralophidea Girault, 1915a: 168. Type-species: *Paratetralophidea ornatipennis* Girault, by original designation.

DISTRIBUTION AND SPECIES. One species, Australia only: *ornatipennis* Girault (1915a: 169), also at least two further species from Australia and Indonesia (BMNH, BPBM).

BIOLOGY. The species from Indonesia (Seram I.) has been reared from heteropteran eggs possibly belonging to the family Coreidae (Heteroptera).

COMMENTS. The genus is closely related to *Ovaloencyrtus* and probably also *Xenoencyrtus* and *Ooencyrtus* (Microteryini, subtribe Ooencyrtina) from which it can be separated by the characters given in the key.

PARECHTHRODRYINUS Girault

(Key couplet: 417. Figs 206, 207)

Parechthrodryinus Girault, 1916c: 480. Type-species: *Parechthrodryinus convexus* Girault, by original designation.

DISTRIBUTION AND SPECIES. Eight species, Palaearctic, Afrotropical, Oriental and Australasian; five species from review area: *albiclavatus* (Shafee, Alam & Agarwal, 1975: 63) (India), *clavicornis* (Cameron, 1913: 101) (India, Sri Lanka), *convexus* Girault (1916c: 480) (Java), *hemiaspidoproctis* (Subba Rao, 1967: 5) (India) and *nigriclavatus* (Shafee, Alam & Agarwal, 1975: 60) (India).

REFERENCE. Review of Indian species: Shafee *et al.* (1975: 59–63).

BIOLOGY. Parasites of Coccidae and Keriidae (Homoptera).

COMMENTS. Placed in the tribe Cheiloneurini (Encyrtinae), it is very close to *Tyndarichus* from which it can be very difficult to separate if the biology is not known (see characters given in key) (see also comments under *Tyndarichus*).

PARACTROMOIDEA Girault

(Key couplets: 83, 119, 147, 157, 245, 386. Figs 79, 400)

Paractromoidella Girault, 1915a: 175. Type-species: *Paractromoidella thackerayi* Girault, by monotypy. *Eucheloneuropsis* Girault, 1922b: 104. Type-species: *Eucheloneuropsis lotae* Girault, by original designation.

DISTRIBUTION AND SPECIES. Nine species, all Australian: *abnormis* (Girault, 1917g: 136) (**comb. n.** from *Dinocarsis*), *acaciae* Girault (1931: 1), *holbeini* (Girault, 1923e: 6) (**comb. n.** from

Dinocarsis), *laticincta* (Girault, 1932a: 3) (**comb. n.** from *Epanusia*), *lotae* (Girault, 1922b: 105), *lowelli* (Girault, 1922b: 105) (**comb. n.** from *Eucheiloneuropsis*), *pacorus* (Walker, 1839: 39) (**comb. n.** from *Encyrtus*), *regalis* (Girault, 1922b: 106) (**comb. n.** from *Eucheiloneuropsis*) and *thackerayi* Girault (1915a: 175), also many other species from New Caledonia, Australia and New Zealand (BMNH, BPBM, UCR, DSIR).

REFERENCE. Noyes (1978: 551–552).

BIOLOGY. Unknown.

COMMENTS. The single extant male of *Encyrtus pacorus* Walker is here designated LECTOTYPE (BMNH) and has been so labelled; it belongs to *Parectromoidella*.

The holotype female of *Dinocarsis abnormis* cannot be located but from the description it must belong to *Parectromoidella*.

The genus belongs to the same group as *Epanusia*, *Cryptanusia* and *Cyrtocoryphes* (see comments under *Cryptanusia*).

PARECTROMOIDES Girault

(Key couplets: 326, 447)

Parectromoides Girault, 1915a: 171. Type-species: *Parectromoides magniscutellum* Girault, by original designation.

DISTRIBUTION AND SPECIES. Two species, Australia only: *magniscutellum* Girault (1915a: 171) and *varipes* (Girault, 1915a: 166) (**comb. n.** from *Parastenoterys*), also further undetermined material from Australia and New Zealand (BMNH, DSIR, QM, ANIC).

BIOLOGY. Unknown.

COMMENTS. Close to *Clausenia* (here placed in the tribe Charitopidini, Tetracneminae) and superficially very similar. It differs mainly in having very much deeper, more irregular sculpture on the head and dorsum of thorax, the forewing with a filum spinosum present (very unusual in the Tetracneminae) and the gaster relatively shorter and more apically rounded (acute in *Clausenia*).

PARENCYRTOMYIA Girault

(Key couplets: 232, 372, 463. Fig. 137)

Parencyrtomyia Girault, 1915a: 111. Type-species: *Parencyrtomyia niveiclava* Girault, by original designation.

DISTRIBUTION AND SPECIES. One species, Australia only: *niveiclava* Girault (1915a: 111), also undetermined material, including at least one undescribed species, from Vietnam, Solomon Is. and Papua New Guinea (BPBM).

BIOLOGY. Unknown.

COMMENTS. We are unable to place the genus according to Trjapitzin's (1973b) classification of the Encyrtinae, but possibly it belongs to the same group of genera as *Tachinaephagus*, *Rhytidothorax* and *Parastenoterys* (see comments under *Parastenoterys*). It differs from these genera in having a relatively shorter propodeum and the hypopygium not extending more than half way along the gaster. It may also be related to *Aseirba*, *Hemileucocerus* and *Austroencyrtus* (see comments under *Aseirba*).

PASULINIA gen. n.

(Key couplet: 440. Figs 228–230, 401–406)

Type-species: *Pasulinia gentha* sp. n. Gender: feminine.

♀. *Head*. In facial view clearly broader than long, in profile about one-half longer than broad, almost straight from mouth margin to about half way up antennal scrobes and then gradually curved inwards in a near semicircle to occipital margin. Eye with posterior margin very slightly concave, almost straight, only slightly longer than broad, with sparse inconspicuous setae each not longer than the diameter of a facet and not clearly separated from occiput by a more or less rounded occipital margin. Malar space about half eye length, with sulcus present. Frontoververtex between one-fifth and one-quarter head width; ocelli forming an angle of about 45°, the posterior ones nearly four times their own diameter from occipital margin and a little less than their diameters from eye margin. Antennal scrobes shallow, meeting dorsally and reaching slightly more than half way from antennal toruli to anterior ocellus; antennal torulus separated from mouth margin by about its own length and from other torulus by about one and one-half times its own length, its dorsal margin about level with ventral eye margins; clypeal margin almost straight but extremely shallowly excised medially. Antennal scape much longer than minimum width of frontoververtex, subcylindrical, nearly five times as long as broad, pedicel conical and slightly more than one third length of scape and about twice as long as any of the funicle segments, the first three of which are a little longer than broad, subquadrate, the last three of which are clearly transverse, the funicle distinctly widening distally; clava three-segmented, more or less obliquely truncate, the outer suture clearly converging with inner one, clava about two-thirds length of funicle; longitudinal sensillae on all flagellar segments except the first. Frontoververtex with shallow, raised, reticulate sculpture, at top of scrobes more or less squamiform-reticulate and between eyes and genae becoming more longitudinally elongate; setae on frontoververtex dark, sparse and not conspicuous. Mandible with one very small lower tooth and a very broad truncation, almost edentate; maxillary palpus three-segmented, labial palpus two-segmented.

Thorax. In side view slightly dorso-ventrally flattened with mesopleurum and propodeum narrowly in contact with hind coxa and dorsally with mesoscutum and scutellum very flat. In dorsal view with posterior margin of pronotum very concave, strongly angled centrally; visible part of mesoscutum about one-half broader than long, with notaular lines absent, with posterior margin almost straight but produced a little posteriorly; axillae more or less meeting; scutellum very slightly broader than long, a little shorter than mesoscutum, with apex broadly rounded; propodeum medially about one-quarter length of scutellum. Mesoscutum with moderately deep, raised reticulate sculpture; scutellum with distinctly deeper, raised, reticulate sculpture of slightly smaller mesh; propodeum medially with shallow, irregular, raised reticulate sculpture; mesopleurum with moderately deep, raised, reticulate sculpture. Forewing hyaline, but faintly suffused yellow in middle one-third or so, wing about three times as long as broad, linea calva not interrupted or closed, filum spinosum present; venation yellowish brown; submarginal vein without a conspicuous hyaline break and not swollen apically; marginal vein about four or five times as long as broad, clearly longer than stigmal; postmarginal vein almost absent; costal cell nearly 25 times as long as broad, with a single line of setae in its apical one-sixth. Hindwing about four-fifths length of forewing, about five and one-half times as long as broad, with marginal fringe about one-half maximum wing width. Mid tibial spur a little shorter than basal mid tarsal segment.

Gaster. About as long as thorax with cercal plates in anterior half, ovipositor hardly exerted, hypopygium reaching to about two-thirds to three-quarters along gaster; paratergites absent, last tergite about two-thirds length of mid tibia; gonostyli free, about one-quarter as long as ovipositor which is nearly as long as mid tibia.

♂. Unknown.

COMMENTS. The shape of the mandible and head, and the forewing venation suggest that this genus is related to *Coccidencyrtus* (tentatively placed in the Habrolepidini by Trjapitzin, 1973), but also possibly related to *Zaomma* and *Mahencyrtus* (placed in the Cheiloneurini). *Pasulinia* can be separated from *Coccidencyrtus* by the relatively narrow frontoververtex and structure of the clava (long and apically rounded with sutures parallel in *Coccidencyrtus*), and from the genera of the Cheiloneurini by the structure of the mandible.

***Pasulinia gentha* sp. n.**

(Figs 228–230, 401–406)

♀. Length: 0.86–1.03 mm (holotype, 1.03 mm).

Colour. Head black with purple reflections, slightly brassy or greenish on lower parts of face; antenna with scape testaceous yellow, pedicel and flagellum pale brown to dark brown; pronotum black with some slight brassy reflections, mesoscutum shining blue-green edged purplish, anteriorly more greenish, axillae

black with green, brassy or purple reflections, scutellum shining green slightly mixed coppery anteriorly and apically; forewing hyaline, slightly suffused pale yellow in middle one-third; legs excluding fore coxa completely yellow to slightly dusky orange, fore coxa brown; gaster dark purplish brown with some slight brassy reflections, basal tergite and venter mostly orange; exerted part of gonostyli orange-brown.

Head. Relative measurements (holotype): head length 49, head width (facial view) 58, head width (side view) 33, minimum frontovertex width 14, malar space 19, eye length 36, eye width 32, POL 4.5, OOL 2, scape length 27, scape width 6, other proportions of antenna as in Fig. 230; mandible as in Fig. 229; head in side view as in Fig. 228.

Thorax. Relative measurements (holotype): forewing length 132, width 45, other proportions of forewing as in Fig. 401; hindwing length 104, width 18; forewing as in Fig. 401, sculpture of mesoscutum and scutellum as in Figs 402, 403, mid tibia and tarsus as in Fig. 405.

Gaster. Relative lengths (paratype): last tergite 34, ovipositor 45, gonostyli 11, [mid tibia 50]; genitalia as in Fig. 406, hypopygium as in Fig. 404.

♂. Unknown.

DISTRIBUTION. India, Sulawesi, Papua New Guinea.

BIOLOGY. Unknown.

MATERIAL EXAMINED

Holotype ♀, **Sulawesi:** Tengah, nr Morowali, Ranu River Area, ii.1980, lowland rain forest, Malaise trap (*M. J. D. Brendell*) (BMNH).

Paratypes. **Sulawesi:** 1 ♀, Tengah, same data as holotype, iii.1980 (*M. J. D. Brendell*). **Papua New Guinea:** 1 ♀, East Highlands, Kundiawa, 6.i.1965, Malaise trap (*J. Sedlacek*). **India:** 1 ♀, Kerala, Periyar Animal sanctuary, 5–15.x.1979 (*J. S. Noyes*) (BMNH, BPBM).

PENTACLADOCERUS Erdős

(Key couplet: 355)

Pentacladocerus Erdős, 1963: 287. Type-species: *Pentacladocerus matranus* Erdős, by original designation.

DISTRIBUTION AND SPECIES. Three species, Palaearctic, plus one unidentified specimen from India (BMNH).

REFERENCE. Review of species: Trjapitzin (1968: 111–114).

BIOLOGY. Unknown.

COMMENTS. Placed in the Bothriothoracini, subtribe Coenocercina and separated from the nearest related genera (*Cerchysiella* and *Zaommoencyrtus*) by the character given in the key.

PENTELICUS Howard

(Key couplets: 121, 207. Fig. 126)

Pentelicus Howard, 1895: 611. Type-species: *Pentelicus aldrichi* Howard, by monotypy.

Hemaenasius Ashmead, 1900b: 374. Type-species: *Hemaenasius confusus* Ashmead, by original designation. **Syn. n.**

Epaenasomyia Girault, 1917d: 3. Type-species: *Epaenasomyia varicornis* Girault, by original designation. **Syn. n.**

Cowperella Girault, 1935: 4. Type-species: *Cowperella aeneifrons* Girault, by monotypy. **Syn. n.**

DISTRIBUTION AND SPECIES. Five species, Holarctic and Australian; one species from review area: *aeneifrons* (Girault, 1935: 4) (**comb. n.** from *Cowperella*) (Australia), also undetermined material from India and Taiwan to Australia (BMNH, BPBM).

REFERENCES. Notes on species: Trjapitzin & Gordh (1979), Khlopunov (1979).

BIOLOGY. Unknown.

COMMENTS. We can see no reason for retaining *Hemaenasius* as a distinct genus from *Pentelicus*.

The only major difference between the two genera is the presence of deep piliferous punctures on the head and dorsum of thorax in *Pentelicus* and their absence in the described species of *Hemaenasius*. The undetermined material mentioned above shows virtually a complete range from almost totally smooth sculpture to deeply punctured sculpture.

The classification of Trjapitzin & Gordh (1978b) is curious. They place *Hemaenasius* in the subtribe Hemaenasiina (Discodini) and *Pentelicus* in the subtribe Bothriothoracina (Bothriothoracini), probably because of the difference in sculpture of the described species. *Pentelicus* (as understood here) is probably related to *Leurocerus*, *Proleurocerus*, etc. (see comments under *Leurocerus*) and can be distinguished from these and related genera by the presence of a very shallow median longitudinal ridge or carina along the scutellum.

PHAULOENCYRTUS Girault

(Key couplet: 201. Fig. 120)

Phauloencyrtus Girault, 1940: 150. Type-species: *Phauloencyrtus mirisimilis* Girault, by monotypy.

DISTRIBUTION AND SPECIES. One species only, Australasia: *mirisimilis* Girault (1940: 50) (Sarawak, Australia).

BIOLOGY. Unknown.

COMMENTS. We are unable to place the genus, but the very hairy eyes and structure of the antenna suggest that it may be related to *Exoristobia* or *Parablatticida*.

PHILOSINDIA gen. n.

(Key couplet: 160. Figs 89, 90, 407–410)

Type-species: *Philosindia longicornis* sp. n. Gender: feminine.

♀. *Head*. In facial view a little broader than long, in profile about twice as long as broad, gently curved to top of antennal toruli then strongly curved at top of toruli and almost straight below this, thus the straight part being nearly twice as long as the curved part. Eye with posterior margin straight or very slightly concave, about one-quarter longer than broad, almost naked but with a few sparse, short setae, each much shorter than the diameter of a facet, eye reaching or slightly overreaching occipital margin which is sharp. Malar space a little shorter to distinctly longer than half length of eye, with sulcus absent or present. Frontovortex from one-quarter to about one-half head width; ocelli large, more or less forming a right angle; posterior ocellus much less than to about its own diameter from occipital or eye margin, or much closer to eye margin. Antennal scrobes almost non-existent, not meeting dorsally, separated by a fairly sharp antennal prominence and reaching slightly less than half way from toruli to anterior ocellus; antennal torulus separated from mouth margin by at least one and one-half times its own length and from other torulus by about two-thirds its own length, its ventral margin clearly above or rarely well below ventral margins of eyes; clypeal margin broadly but shallowly excised in middle. Antennal flagellum long, about two to three times as long as head width; scape shorter or slightly longer than minimum width of frontovortex, about three times as long as broad; pedicel conical and subquadrate, clearly much shorter than any of the funicle segments which are subequal in size; clava three-segmented or with segments separated and similar in appearance to funicle so that flagellum has an undifferentiated, nine-segmented appearance; longitudinal sensillae very distinct, present on all flagellar segments; longest setae on flagellum about as long as diameter of segments. Frontovortex with raised, reticulate sculpture of moderate mesh, almost hexagonal in front of anterior ocellus, becoming more longitudinally elongate between scrobes and eyes and on lower parts of face, interantennal prominence with similar sculpture to frontovortex but distinctly shallower; head with fairly long translucent or dark setae, those on frontovortex about as long as or longer than the diameter of the ocelli. Mandible with two teeth and a truncation or obscurely tridentate; maxillary palpus long, four-segmented, labial palpus three-segmented.

Thorax. In side view robust with mesoscutum and scutellum moderately convex, the metapleurum and propodeum together narrowly in contact with hind coxa or slightly separated from it by posterior margin of mesopleurum. In dorsal view with posterior margin of pronotum moderately concave; visible part of mesoscutum nearly twice as broad as long, notaular lines absent, with its posterior margin almost straight but slightly angled outwards in centre; axillae more or less meeting; scutellum about as long as

mesoscutum, clearly convex, about as long as broad, its apex rounded; propodeum medially about one-eighth to one-tenth as long as scutellum. Dorsum of thorax with conspicuous, long, dark setae and shallow irregular, raised, reticulate sculpture, a little shallower than on head except occasionally on scutellum which may be conspicuously deeper; propodeum medially quite smooth or with very few carinae, around spiracles with shallow, raised, irregular sculpture, mesopleurum with very shallow, fine, elongate, reticulate sculpture. Forewing hyaline or almost imperceptibly infuscate in basal two-thirds or so, about two and one-half times as long as broad; linea calva not closed nor interrupted; filum spinosum present; submarginal vein with an indistinct, apical, hyaline break, parastigma not or hardly swollen; costal cell about 13 to 14 times as long as broad, with a single line of setae dorsally in distal half; marginal vein about three to four times as long as broad, about as long as stigmal which in turn is as long as or a little shorter than postmarginal vein. Hindwing about two-thirds as long as forewing, about three and one-half to five times as long as broad, marginal fringe about one-sixth as long as wing width. Mid tibial spur about as long as basal segment of mid tarsus.

Gaster. Shorter than thorax; cercal plates in anterior half; hypopygium reaching to about one-half to two-thirds along gaster; paratergites absent, last tergite about one-half to two-thirds as long as mid tibia; ovipositor not exerted to slightly exerted with exerted part about one-quarter length of gaster, ovipositor at least about as long as mid tibia, gonostyli fused to second valvifers and about one-fifth length of ovipositor or longer.

♂. Unknown.

COMMENTS. This genus belongs to the tribe Microteriyini, subtribe Microteriyina (Encyrtinae) and can be distinguished from all other included genera by the extraordinarily long antenna, relatively high placement of antennal toruli and the long postmarginal vein of the forewing.

Philosindia longicornis sp. n.

(Figs 89, 90, 407–410)

♀. Length: 1.14–1.27 mm (holotype, 1.24 mm).

Colour. Body generally dusky yellowish orange, gaster a little darker; dorsal margin of scape slightly brownish apically, dorsal surface of flagellar segments and whole of two apical flagellar segments brownish; head with translucent setae, scape, mesoscutum and scutellum with conspicuous dark setae; forewing venation yellow.

Head. Malar sulcus present but indistinct, absent towards mouth margin; antennal flagellum a little more than twice as long as maximum head width (2.08–2.23); posterior ocelli a little closer to eye margin than to occipital margin; antennal toruli with lower margins clearly above lower margins of eyes (Fig. 89). Relative measurements (holotype): head width (facial view) 80, head width (side view) 36, head length 70, minimum frontovertex width 33, maximum diameter of posterior ocellus 8, malar space 20, eye length 46, eye width 38, POL 14, OOL 3, scape length 29, scape width 10.5, overall length of flagellum 178, proportions of antenna as in Fig. 407.

Thorax. Scutellum with sculpture similar to that of mesoscutum (Figs 409, 410) and head, not distinctly deeper; propodeum medially smooth, about one-tenth as long as scutellum. Relative measurements (holotype): forewing length 240, width 99, venation as in Fig. 90; hindwing length 156, width 44. The relative width of the hindwing can vary; in one paratype it is almost exactly four times as long as broad.

Gaster. Ovipositor not exerted. Relative lengths (paratype): last tergite 22.5, ovipositor 39, gonostylus 7.5, [mid tibia 42]. Genitalia as in Fig. 408.

♂. Unknown.

DISTRIBUTION. Hong Kong.

BIOLOGY. Unknown.

MATERIAL EXAMINED

Holotype ♀, **Hong Kong**: N.T., Taipokau, 27.viii.1965, light trap (*Lee Kit Ming & Hui Wai Ming*) (BPBM).

Paratypes. **Hong Kong**: 3 ♀, same data as holotype; 1 ♀, same locality and collectors, 3–4.vii.1964 (BMNH, BPBM).

COMMENTS. A further eight species from India, Philippines, Papua New Guinea and Solomon Is. (BMNH, BPBM, AMNH, USNM). They can be distinguished on several characters but mainly

by the relative lengths of antenna to head width, position of antennal toruli in relation to eyes, relative size of eye, coloration of head, length of last tergite of gaster in relation to mid tibia, and relative length of exerted part of ovipositor.

PLAGIOMERUS Crawford

(Key couplet: 51)

Plagiomerus Crawford, 1910: 89. Type-species: *Plagiomerus diaspidis* Crawford, by original designation. *Parahomalopoda* Girault, 1915c: 170. Type-species: *Parahomalopoda peruviansis* Girault, by original designation.

DISTRIBUTION AND SPECIES. Six species, New World, Oriental, Pacific; four from review area: *bangaloriensis* Shafee, Alam & Agarwal (1975: 102) (India), *diaspidis* Crawford (1910: 90) (Hawaiian Is.), *dorceto* Trjapitzin (1969b: 1252) (S. China) and *hospes* Timberlake (1920: 428) (Hawaiian Is.), also undetermined material from Taiwan and Java (BPBM).

REFERENCES. Review of some species: Shafee *et al.* (1975: 101–103); Beardsley (1976: 223).

BIOLOGY. Parasites of Diaspididae (Homoptera).

COMMENTS. The genus is placed in the Habrolepidini, subtribe Habrolepidina (Encyrtinae). It can be separated from related genera by having hyaline wings and a four-segmented funicle with the first joint being shorter than the fourth (see comments under *Coccidencyrtus*).

PLATYRHOPUS Erdős

(Key couplets: 152, 206)

Platyrhopus Erdős, 1955: 40. Type-species: *Platyrhopus delitescens* Erdős, by original designation.

DISTRIBUTION AND SPECIES. Two species, Palaearctic; neither from review area, but one undescribed species from India (BMNH).

REFERENCE. Herthveztzian & Trjapitzin (1974).

BIOLOGY. Parasites of Pseudococcidae (Homoptera).

COMMENTS. Placed in the Anagyrini, subtribe Rhopina (Tetracneminae) and separated from related genera by the characters given in the key.

PRALEUROCERUS Agarwal

(Key couplet: 117. Figs 57, 58, 411)

Paraleurocerus Agarwal, 1966: 68. Type-species: *Paraleurocerus viridis* Agarwal, by original designation. [Homonym of *Paraleurocerus* Girault, 1915.]

Praleurocerus Agarwal, 1974: 394. [Replacement name for *Paraleurocerus* Agarwal.]

DISTRIBUTION AND SPECIES. One species, India and Sri Lanka only: *viridis* (Agarwal, 1966: 70).

BIOLOGY. Parasites of Pseudococcidae (Homoptera).

COMMENTS. The genus is related to *Dinocarsis* Förster (Tetracneminae, Dinocarsini) and can easily be recognised by the flattened antennal flagellum and the thin flange at the apex of the scutellum (Figs 57, 58).

PRIONOMASTIX Mayr

(Key couplets: 224, 278, 373, 429)

Prionomastix Mayr, 1876: 725. Type-species: *Encyrtus morio* Dalman, by monotypy.

Liocarus Thomson, 1876: 115, 121. Type-species: *Encyrtus morio* Dalman, by monotypy.

Chestomorpha Ashmead, 1900b: 370. Type-species: *Chestomorpha biformis* Ashmead, by original designation.

Aprionomastix Girault, 1913a: 68. Type-species: *Aprionomastix fasciatipennis* Girault, by original designation.

DISTRIBUTION AND SPECIES. Seven species, cosmopolitan; none recorded from review area, but several undetermined species from India, Thailand, Vietnam, Malaysia, Sarawak and Philippines (BMNH, BPBM).

REFERENCE. Review of world species: Annecke (1962).

BIOLOGY. Parasites of nymphs of Membracidae (Homoptera).

COMMENTS. Placed in the Prionomasticini, subtribe Prionomasticina (Encyrtinae) (see also comments under *Anagyrodes*).

PRIONOMITOIDES Girault

(Key couplet: 287)

Prionomitoides Girault, 1915a: 118. Type-species: *Prionomitoides viridiscutellum* Girault, by original designation.

DISTRIBUTION AND SPECIES. One species, Australia only: *viridiscutellum* Girault (1915a: 118).

BIOLOGY. Unknown.

COMMENTS. We are unable to place the genus confidently according to Trjapitzin's classification of the Encyrtinae. In general appearance it superficially resembles species of *Ooencyrtus* or *Psyllaephagus*, but differs by having a tridentate mandible and the hypopygium clearly reaching the apex of the gaster. It may belong to the tribe Aphycini.

PROCHEILONEURUS Girault

(Key couplets: 94, 137, 384)

Procheiloneurus Girault, 1920a: 39. Type-species: *Procheiloneurus triguttatipennis* Girault, by original designation.

Raphaelana Girault, 1926b: 66. [Unnecessary replacement name for *Procheiloneurus* Girault.] **Syn. n.**

DISTRIBUTION AND SPECIES. Four species, all Australian: *divinus* (Girault, 1926b: 69) (**comb. n.** from *Eusemionella*), *flaviscutellum* Girault (1924a: 5), *perbellus* Girault (1922a: 43) and *triguttatipennis* Girault (1920a: 39), also several other species, near *perbellus*, from Australia (BMNH, UCR, QM, ANIC).

BIOLOGY. Unknown.

COMMENTS. Girault (1926b) unnecessarily proposed the replacement name *Raphaelana* for *Procheiloneurus* Girault which he thought was a junior homonym of *Prochiloneurus* Silvestri, 1915. According to Article 56a of the *International Code of Zoological Nomenclature* a one letter difference is sufficient to prevent homonymy. Therefore the original name must stand.

The species placed within this genus almost certainly represent a polyphyletic group within the Cheiloneurini. Further study will probably indicate that *flaviscutellum* and possibly also *triguttatipennis* should belong in *Cheiloneurus* (and thus *Procheiloneurus* will become a junior synonym of *Cheiloneurus*). However, in this case it will probably become necessary to describe at least one new genus to accommodate *perbellus* and *divina*. For the present we are separating *Procheiloneurus* from *Cheiloneurus* by the characters given in the key, in particular the presence of two areas of dark setae in the basal cell of the forewing (*Cheiloneurus* has only one) and/or the presence of a white, rectangular spot on each side of the pronotum (absent in *Cheiloneurus*).

PROCHILONEURUS Silvestri

(Key couplets: 103, 125, 254, 257, 357, 362)

Prochiloneurus Silvestri, 1915b: 350. Type-species: *Prochiloneurus pulchellus* Silvestri, by original designation.

Achrysopophagus Girault, 1915a: 89. Type-species: *Achrysopophagus oviductus* Girault, by original designation.

Parachrysopophagus Agarwal, 1965: 65. Type-species: *Achrysopophagus insolitus* Alam, by original designation. [As subgenus of *Achrysopophagus*.]

Neoprochiloneurus Viggiani, 1966: 95. Type-species: *Prochiloneurus bolivari* Mercet, by original designation.

Prochiloneuroides Hayat, Alam & Agarwal, 1975: 61. Type-species: *Prochiloneurus comperei* Viggiani, by original designation.

DISTRIBUTION AND SPECIES. Thirty-two species, cosmopolitan; 20 from review area: *aegyptiacus* Mercet (1929: 360) (India), *agarwali* Hayat (1981a: 23) (India), *albifuniculus* (Hayat, Alam & Agarwal, 1975: 62) (India), *albioviductus* (Girault, 1925b: 92) (**comb. n.** from *Cheiloneurus*) (Australia), *annulatus* (Ferrière, 1951: 190) (**comb. n.** from *Achrysopophagus*) (Indonesia), *aureipleurum* (Girault, 1932a: 4) (**comb. n.** from *Achrysopophagus*) (Australia), *clavatus* (Girault, 1915a: 89) (Australia), *comperei* Viggiani (1970: 68) (India), *hayati* Shafee, Alam & Agarwal (1975: 53) (India), *indicus* Shafee, Alam & Agarwal (1975: 49) (India), *insolitus* (Alam, 1961: 235) (India), *io* (Girault, 1920c: 187) (Java, Philippines), *javanicus* (Ferrière, 1951: 188) (**comb. n.** from *Achrysopophagus*) (Indonesia), *nigricornis* (Girault, 1920c: 187) (**comb. n.** from *Achrysopophagus*) (Hong Kong, Philippines), *nigriflagellum* (Girault, 1932a: 6) (**comb. n.** from *Achrysopophagus*) (Australia), *oviductus* (Girault, 1915a: 89) (Australia), *rex* (Girault, 1920c: 188) (Java, Philippines, Hawaiian Is.), *taurus* (Girault, 1923a: 49) (**comb. n.** from *Achrysopophagus*) (Australia), *testaceus* (Agarwal, 1965: 68) (India) and *valparianus* Mani & Kaul *in Mani et al.* (1974: 66) (India), also undetermined material, containing several undescribed species, from India, Hong Kong, Papua New Guinea, Australia, New Hebrides and Hawaiian Is. (BMNH, BPBM, CNC, QM, ANIC, HC).

REFERENCE. Review of Indian species: Hayat (1981a: 22–26).

BIOLOGY. Hyperparasites, via other encyrtids, of various families of Coccoidea (Homoptera), mainly Pseudococcidae and Coccidae, and also Coccinellidae (Coleoptera).

COMMENTS. Placed in the tribe Cheiloneurini. It is most closely related to *Cheiloneurus* and *Tineophoctonus* and can be separated from these by having the hypopygium reaching the apex of the gaster, the ovipositor well exerted and the gaster apically rounded (not gradually tapered as in species of the other genera with an exerted ovipositor).

PROLEUROCEROIDES Shafee, Alam & Agarwal

(Key couplet: 401. Figs 205, 416)

Proleuroceroides Shafee, Alam & Agarwal, 1975: 42. Type-species: *Proleuroceroides pyrillae* Shafee, Alam & Agarwal, by original designation.

DISTRIBUTION AND SPECIES. Two species, both known only from India and possibly synonymous: *pyrillae* (Crawford, 1916: 102) (**comb. n.** from *Ooencyrtus*) and *pyrillae* Shafee, Alam & Agarwal (1975: 42), also undetermined material from Sulawesi (BMNH).

BIOLOGY. Parasites of eggs of Lophopidae (Homoptera).

COMMENTS. The holotype female of *Ooencyrtus pyrillae* Crawford has been examined (USNM). It is very close to, if not the same as, *pyrillae* Shafee, Alam & Agarwal and for this reason we are not proposing a replacement name for the latter.

Proleuroceroides is closely related to *Proleurocerus* (Encyrtinae, tribe Proleurocerini) and can be separated by the characters given in the key, notably by the dorsum of the thorax being non-metallic (metallic in *Proleurocerus*) (see also comments under *Leurocerus*).

PROLEUROCERUS Ferrière

(Key couplet: 124. Figs 59, 60)

Proleurocerus Ferrière, 1935: 402. Type-species: *Proleurocerus fulgoridis* Ferrière, by original designation.

Arachnosinis Compere & Zinna, 1955: 112. Type-species: *Arachnosinis zululandiae* Compere & Zinna, by original designation.

DISTRIBUTION AND SPECIES. Two species, Afrotropical and Oriental; only one known from review area: *fulgoridis* Ferrière (1935: 403) (India), and one, undescribed species from India (BMNH).

BIOLOGY. Parasites of eggs of spiders (Araneida) and Eurybrachidae (Homoptera).

COMMENTS. Placed in the tribe Proleurocerini (Encyrtinae) but probably also related to *Leurocerus*, *Pentelicus*, etc. (see comments under *Leurocerus*).

PROTYNDARICHOIDES Noyes

(Key couplets: 303, 318, 320, 397, 443. Figs 157, 231–234)

Protyndarichoides Noyes, 1980: 224. Type-species: *Protyndarichoides nigriceps* Noyes, by original designation.

DISTRIBUTION AND SPECIES. Two described species, Neotropical, European, Afrotropical, Oriental and Australasian; one species from review area: *cinctiventris* (Girault, 1934b: 1) (**comb. n.** from *Echthrogonatopus*) (Australia), also many undescribed species from India, Bangladesh, S. China, Malaysia, Papua New Guinea, New Caledonia and New Zealand (BMNH, BPBM, GC, DSIR).

BIOLOGY. Unknown, but has been found in association with scolytid beetles (Coleoptera, Scolytidae) on *Pinus* sp. in France (BMNH).

COMMENTS. The material from New Zealand and France is very close to *cinctiventris* and may be this species.

We are unable to place the genus satisfactorily but it may belong in the Cheiloneurini, as suggested previously (Noyes, 1980: 225).

PSEUDAPHYCUS Clausen

(Key couplet: 66. Figs 25–27)

Pseudaphycus Clausen, 1915: 41. Type-species: *Aphycus angelicus* Howard, by original designation.

Psilomirinus Brèthes, 1916: 424. Type-species: *Psilomirinus flavidulus* Brèthes, by original designation.

DISTRIBUTION AND SPECIES. Twenty-five species, cosmopolitan; two from review area: *orientalis* Ferrière (1937: 317) (Philippines) and *utilis* Timberlake (1923: 323) (Hawaiian Is.), also further undetermined material from S. China and Cook Is. (BMNH, BPBM, DSIR).

REFERENCE. World revision: Gahan (1946).

BIOLOGY. Parasites of Pseudococcidae (Homoptera).

COMMENTS. *Pseudaphycus utilis* Timberlake is possibly out of place in this genus, having the dorsum of the thorax convex and clothed in conspicuous dark setae. However, at present we do not regard these differences as sufficient to warrant separation into another genus.

Placed in the Aphycini, subtribe Aphycina (Encyrtinae). It is very close to *Acerophagus* and *Pseudectroma* and can be separated from these genera by the characters given in the key.

PSEUDECTROMA Girault

(Key couplet: 63. Fig. 28)

Pseudectroma Girault, 1915a: 161. Type-species: *Pseudectroma auricorpus* Girault, by original designation.

Timberlaskia Mercet, 1925a: 9. Type-species: *Acerophagus europaeus* Mercet, by original designation.

Syn. n.

DISTRIBUTION AND SPECIES. Seven described species, Neotropical, European, Afrotropical, Australasian; three species from review area, all Australian: *auricorpus* Girault (1915a: 161), *bryanti* Girault (1922e: 150) and *obscura* Girault (1923c: 143), also further undetermined material from Malaysia and Cook Is. (BMNH, DSIR).

BIOLOGY. Parasites of Pseudococcidae (Homoptera).

COMMENTS. The clava of *bryanti* may be solid and thus the species could run to either *Acerophagus* or *Indaphycus* in the key. However, we are retaining it in its original combination pending closer examination of the single extant syntype (QM) or more freshly collected material.

The genus belongs to the Aphycini, subtribe Aphycina (Encyrtinae) and is probably closest to *Acerophagus*. Generally it can be distinguished from *Acerophagus* by having a two-segmented clava, whereas *Acerophagus* usually has three segments. The relative width of the frontovertex is probably a more reliable character: in *Acerophagus*, at its narrowest point, it is not wider than the scape length, whereas in *Pseudectroma* it is at least about one-quarter wider than the scape length. Prinsloo (1982) has suggested that these and some related genera may eventually be synonymised and we echo these sentiments. However, he also described two new species from South Africa (under *Timberlaskia*), each with a relatively narrow frontovertex. Although both of these species have a two-segmented clava, they may actually belong in *Acerophagus* as defined here.

PSEUDOCOCCOBIUS Timberlake

(Key couplets: 153, 167, 360, 390. Fig. 197)

Pseudococcobius Timberlake, 1916: 563. Type-species: *Aphycus terryi* Fullaway, by original designation.

Australrhopoideus Girault, 1926b: 58. Type-species: *Australrhopoideus melleicorpus* Girault, by monotypy. **Syn. n.**

Pezaphycus Nowicki, 1926: 105. Type-species: *Pezaphycus obenbergeri* Nowicki, by original designation.

Syn. n.

DISTRIBUTION AND SPECIES. Four species, Europe, Australia, Pacific; three species from review area: *melleicorpus* (Girault, 1926b: 58) (**comb. n.** from *Australrhopoideus*) (Australia), *quinqueguttatus* (Girault, 1925b: 93) (**comb. n.** from *Aphycus*) (Australia) and *terryi* (Fullaway, 1913: 281) (Hawaiian Is.), also undetermined material from Hong Kong (BPBM).

BIOLOGY. Parasites of Pseudococcidae (Homoptera).

COMMENTS. *Pseudococcobius* has, in the past, been treated as a synonym of *Aphycus*, although *Pezaphycus* has generally been regarded as a distinct genus (even though their respective type-species are extremely close). We have reinstated it as a good genus since it does appear to differ significantly from species that we regard as belonging to *Aphycus*, notably in the very different head shape and relatively smaller eye with a convex posterior margin (that in *Aphycus* is slightly concave, thus giving the eye a kidney-shaped appearance). There are also differences in structure of the thorax (*Pseudococcobius* has notaular lines always reaching about one-third to one-half way across the mesoscutum and the sculpture of the thoracic dorsum shallow and smooth). In general the antenna is also shorter, with the clava about as long as or longer than the funicle, whereas in *Aphycus* the clava is shorter than the funicle.

Pseudococcobius belongs to the Aphycini, subtribe Aphycina (Encyrtinae).

PSYLLAEPHAGUS Ashmead

(Key couplets: 142, 181, 204, 218, 252, 289, 301, 345, 433, 448, 456, 462, 495, 525.
Figs 74, 75, 102, 121, 122)

- Psyllaephagus* Ashmead, 1900b: 382. Type-species: *Encyrtus pachypsyllae* Howard, by original designation.
- Mirocerus* Ashmead, 1904c: 309. Type-species: *Mirocerus peyelae* Ashmead, by original designation.
- Calocerineloides* Girault, 1913e: 111. Type-species: *Calocerineloides ramosa* Girault, by original designation. **Syn. n.**
- Epanagyrs* Girault, 1915a: 160. Type-species: *Epanagyrs punctatiscutum* Girault, by original designation. **Syn. n.**
- Anagyropsis* Girault, 1917g: 136. Type-species: *Anagyrs purpureus* Girault, by original designation. **Syn. n.**
- Metaprionomitus* Mercet, 1921: 260. Type-species: *Metaprionomitus intermedius* Mercet, by original designation.
- Shakespeareia* Girault, 1928a: 3. Type-species: *Shakespeareia flabellata* Girault, by monotypy.
- Psylleocyrtus* Tachikawa, 1955: 63. Type-species: *Psylleocyrtus syntomozae* Tachikawa, by original designation.
- Calluniphilus* Erdős, 1961: 413. Type-species: *Calluniphilus vendicus* Erdős, by monotypy.
- Ooencyrtoides* Hoffer, 1963: 568. Type-species: *Ooencyrtus albopilosus* Hoffer, by original designation.
- Propsyllaephagus* Blanchard in De Santis, 1964: 235. Type-species: *Propsyllaephagus trellesi* Blanchard, by original designation.
- Mercetia* Bakkendorf, 1965: 139. Type-species: *Copidosoma lusitanicum* Mercet, by original designation.
- Kaszabicyrtus* Szelenyi, 1971: 389. Type-species: *Kaszabicyrtus acutigastri* Szelenyi, by original designation.

DISTRIBUTION AND SPECIES. About 150 species, cosmopolitan; 107 species from review area, all from Australia except *aligarhensis* which is from India: **abyssus* Riek (1962d: 710), *aeneoculex* (Girault, 1929b: 312) (**comb. n.** from *Coccidoxenus*), *albiclava* (Girault, 1915a: 135) (**comb. n.** from *Anagyrs*), *alienus* Riek (1962d: 707), *aligarhensis* Shafee, Alam & Agarwal (1975: 100), *anna* (Girault, 1938: 83) (**comb. n.** from *Anagyropsis*), *aquilus* Riek (1962d: 699), **arctatus* Riek (1962d: 713), *arduus* Riek (1962d: 714), **argutus* Riek (1962d: 715), *arsanes* (Walker, 1839: 38) (**comb. n.** from *Encyrtus*), *ascitus* Riek (1962d: 704), **asser* Riek (1962d: 712), **atavus* Riek (1962d: 701), **atratus* Riek (1962d: 699), *attenuatus* Riek (1962d: 711), *auricorpus* (Girault, 1915a: 133) (**comb. n.** from *Anagyrs*), *australensis* Girault (1914a: 29) (**comb. n.** from *Anagyrs*), *avus* Riek (1962d: 706), **basileus* Riek (1962d: 721), *blandus* Riek (1962d: 721), **bliteus* Riek (1962d: 722), *boletus* Riek (1962d: 718), **bolus* Riek (1962d: 719), **brachiatus* Riek (1962d: 726), *brevicornis* (Girault, 1926c: 129) (**comb. n.** from *Coccidoxenus*), *broccus* Riek (1962d: 716), *bruchus* Riek (1962d: 720), *burnsi* (Girault, 1921a: 2) (**comb. n.** from *Anagyropsis*), *carinatus* Riek (1962d: 735), *cellinini* (Girault, 1915a: 134) (**comb. n.** from *Anagyrs*), *channingi* (Girault, 1913e: 111) (**comb. n.** from *Anagyrs*), *cicada* (Girault, 1915a: 137) (**comb. n.** from *Anagyrs*) (= *Paraenasomyia dubia* Girault, 1923a: 48 **syn. n.**), *cinctorum* (Girault, 1923a: 47) (**comb. n.** from *Paraenasomyia*), **clarus* Riek (1962d: 745), *compactus* (Girault, 1923a: 50) (**comb. n.** from *Coccidoxenus*), *concisus* Riek (1962d: 747), *cornuatus* Riek (1962d: 731), **cornuphagus* Riek (1962d: 754), **dignus* Riek (1962d: 724), **discretus* Riek (1962d: 723), *dius* (Girault, 1915a: 137) (**comb. n.** from *Anagyrs*), *dyari* (Girault, 1915a: 137) (**comb. n.** from *Anagyrs*), **emarginatus* Riek (1962d: 731), *emersoni* (Girault, 1913e: 113) (**comb. n.** from *Anagyrs*), **excisus* Riek (1962d: 737), **exiguus* Riek (1962d: 748), **facetus* Riek (1962d: 745), **facilis* Riek (1962d: 741), **faustus* Riek (1962d: 740), *flabellatus* (Girault, 1928a: 3), **fundus* Riek (1962d: 742), **funiculus* Riek (1962d: 738), *gemitus* Riek (1962d: 755), *grotii* (Girault, 1915a: 135) (**comb. n.** from *Anagyrs*), *guttatipes* (Girault, 1915a: 134) (**comb. n.** from *Anagyrs*), *hardyi* (Girault, 1922f: 1) (**comb. n.** from *Blastothrix*), *hegeli* (Girault, 1915a: 136) (**comb. n.** from *Anagyrs*), *hirtus* Riek (1962d: 744), *howardi* (Girault, 1915a: 134) (**comb. n.** from *Anagyrs*), *irvingi* (Girault, 1922a: 44) (**comb. n.** from *Anagyropsis*), **longissimus* Riek (1962d: 733), *longistylus* (Girault, 1929b: 312) (**comb. n.** from *Anagyropsis*), *mazzinini* (Girault, 1915a: 133) (**comb. n.** from *Anagyrs*), *mercurius* (Girault, 1922a: 41)

(**comb. n.** from *Anagyropsis*), *minutellus* (Girault, 1915a: 171) (**comb. n.** from *Tetracnemella*), **neoxenus* Riek (1962d: 752), *novipurpureus* (Girault, 1915a: 136) (**comb. n.** from *Anagyropsis*), *pallidipes* (Girault, 1915a: 81) (**comb. n.** from *Aenasiella*), **paradoxus* Riek (1962d: 705), *parvus* Riek (1962d: 749), *pegasus* (Girault, 1923a: 48) (**comb. n.** from *Paraenosomyia*), *penni* (Girault, 1913e: 112) (**comb. n.** from *Anagyropsis*), *perplexus* Riek (1962d: 750), *positus* Riek (1962d: 729), *probus* Riek (1962d: 736), *prolatus* Riek (1962d: 734), *punctatiscutum* (Girault, 1915a: 160) (**comb. n.** from *Epanagyropsis*), *purpureus* (Girault, 1915a: 133) (**comb. n.** from *Anagyropsis*), **quadriannellus* Riek (1962d: 751), *quadricyclus* Riek (1962d: 751), *ramosus* (Girault, 1913e: 111) (**comb. n.** from *Calocerineloides*), *resolutus* Riek (1962d: 730), *richteri* (Girault, 1923c: 142) (**comb. n.** from *Anagyropsis*), *rubensi* (Girault, 1932a: 1) (**comb. n.** from *Coccidoxenus*), *semicitripes* (Girault, 1926b: 66) (**comb. n.** from *Coccidoxenus*), *similis* Riek (1962d: 738), *smaragdus* (Girault, 1939a: 19) (**comb. n.** from *Anagyropsis*), *spondyliaspidis* (Girault, 1939a: 19) (**comb. n.** from *Anagyropsis*), *spongitus* (Girault, 1915a: 136) (**comb. n.** from *Anagyropsis*), *subgiganteus* (Girault, 1915a: 138), (**comb. n.** from *Anagyropsis*) (= *Psyllaephagus usticius* Riek, 1962d: 695 **syn. n.**), *suburbis* (Girault, 1926b: 67) (**comb. n.** from *Blastothrix*) (= *Psyllaephagus fuscus* Riek, 1962d: 753 **syn. n.**), *terraefilius* (Girault, 1938: 83) (**comb. n.** from *Anagyropsis*), *turbulentus* (Girault, 1920a: 48) (**comb. n.** from *Anagyropsis*), *turneri* (Girault, 1925b: 100) (**comb. n.** from *Blastothrix*), **uncinatus* Riek (1962d: 691), *unus* Riek (1962d: 697), **utilis* Riek (1962d: 693), *viridiscutellum* (Girault, 1915a: 171) (**comb. n.** from *Tetracnemella*), *westralis* Riek (1962d: 714), *worcesteri* (Girault, 1915a: 139) (**comb. n.** from *Coccidoxenus*), *wundti* (Girault, 1915a: 140) (**comb. n.** from *Coccidoxenus*), *xenus* Riek (1962d: 714), **xi* Riek (1962d: 728), *xuthus* (Walker, 1839: 38) (**comb. n.** from *Encyrtus*), **ypsilon* Riek (1962d: 732), and *zameis* (Walker, 1839: 39) (**comb. n.** from *Encyrtus*), also much undetermined material from throughout the region (BMNH, BPBM, DSIR, CNC, QM, ANIC, HC).

REFERENCES. Revision of some Australian species: Riek (1962d); key to Palaearctic species: Trjapitzin (1981).

BIOLOGY. Parasites or hyperparasites of nymphs of Psyllidae (Homoptera).

COMMENTS. The single extant syntype female of *Encyrtus arsanes* Walker (BMNH) is here designated LECTOTYPE. The single extant syntype male of *Encyrtus zameis* Walker (BMNH) is here designated LECTOTYPE; it is lacking both pairs of wings. There are two syntypes of *Encyrtus xuthus* Walker in the BMNH; one is in very poor condition and the other does not quite fit Walker's description. They both belong to *Psyllaephagus*, but we are not selecting a lectotype for this species at present.

Riek (1962d) described a number of species from Australia. Unfortunately he failed to label the holotypes (or paratypes) of any of his species even though he cited these in his descriptions. During a visit to ANIC, Canberra, one of us (JSN) selected a primary type from those specimens of the type-series of each species where the data of more than one specimen agreed with the data of the holotype of that species as published by Riek. The names of species for which this has been done are preceded in the above list by an asterisk (*). These specimens are here designated LECTOTYPE and have been labelled as such.

Several species here placed in other genera may actually belong in *Psyllaephagus*, e.g. *Aenasiella sidneyi* (Girault) and other species placed in that genus and also *Parachalcerinys nonaericornis* Girault. *Psyllaephagus* is so enormously complex in Australia that it is exceedingly difficult to define its limits and there are possibly as many as 1,000 species to be found there.

Psyllaephagus belongs to the tribe Trechnitini, subtribe Metaprimonitina and is largely characterised by its brightly metallic green or blue-green colour, punctiform marginal vein of the forewing, the mandible having one or two teeth and a broad truncation, and the hypopygium not extending more than two-thirds along the gaster. However, there are exceptions to each of these characters.

PSYLLAPHYCUS Hayat

(Key couplet: 411)

Psyllaphycus Hayat, 1972: 207. Type-species: *Psyllaphycus diaphorinae* Hayat, by original designation.DISTRIBUTION AND SPECIES. One species, India only: *diaphorinae* Hayat (1972: 208).

BIOLOGY. Parasites of nymphs of Psyllidae (Homoptera).

COMMENTS. Placed in the Microteriyini, subtribe Syrphophagina (Encyrtinae). It can easily be distinguished from related genera by the bright yellow colour of the body and the mandible having a single tooth and a broad truncation.

RAFFAELLIA Girault

(Key couplet: 69)

Raffaellia Girault, 1922d: 205. Type-species: *Raffaellia sidneyi* Girault, by monotypy.*Raffaellisca* Ghesquière, 1946: 369. [Unnecessary replacement name for *Raffaellia* Girault.] **Syn. n.**DISTRIBUTION AND SPECIES. One species, Australia only: *sidneyi* (Girault, 1922d: 205).

BIOLOGY. Unknown.

COMMENTS. Very close to *Copidosomopsis* (tribe Copidosomatini, subtribe Copidosomatina) from which it can be separated using the characters given in the key.**RHOPALENCYRTOIDEA** Girault

(Key couplets: 219, 300, 369. Fig. 123)

Rhopalencyrtoidea Girault, 1915a: 101. Type-species: *Rhopalencyrtoidea purpureicorpus* Girault, by original designation.DISTRIBUTION AND SPECIES. Three species, all Australian: *austrina* Girault (1929b: 313), *perplexa* (Girault, 1925a: 3) (**comb. n.** from *Nezarhopalus*) and *purpureicorpus* Girault (1915a: 101).

BIOLOGY. Unknown.

COMMENTS. Related to *Coccidoctonus* and *Teleterebratus* (see comments under *Coccidoctonus*). It can be separated from other related genera by having the apex of the hypopygium more or less reaching the apex of the gaster and not beyond, and the forewing having the postmarginal vein longer than the stigmal.**RHOPUS** Förster

(Key couplets: 84, 170, 273, 395, 404. Figs 40, 91, 412–414)

Rhopus Förster, 1856: 34. Type-species: *Encyrtus piso* Walker, by original designation.*Xanthoencyrtus* Ashmead, 1902: 302. Type-species: *Xanthoencyrtus nigroclavatus* Ashmead, by monotypy.*Scelioencyrtus* Girault, 1915a: 161. Type-species: *Scelioencyrtus nigriclavus* Girault, by original designation.*Mirastymachus* Girault, 1915a: 166. Type-species: *Mirastymachus europaeus* Girault, by original designation.*Pholidoceras* Mercet, 1918: 237. Type-species: *Pholidoceras brachyptera* Mercet, by monotypy.*Pholidocerodes* Ferrière, 1956: 358. Type-species: *Pholidoceras parvula* Mercet, by original designation.DISTRIBUTION AND SPECIES. Thirty-six species, cosmopolitan; 17 species from review area: *apterus* (Timberlake, 1919b: 201) (Hawaiian Is.), *bridwelli* (Timberlake, 1920: 420) (Hawaiian Is.), *desantisiellus* Ghesquière (1957: 18) (India), *extraclavus* (Girault, 1922e: 149) (**comb. n.** from *Xanthoencyrtus*) (Australia), *fullawayi* (Timberlake, 1919b: 204) (India, Hawaiian Is.), *garibaldia* (Girault, 1933: 4) (**comb. n.** from *Xanthoencyrtus*) (Australia), *gramineus* Hayat

(1970a: 110) (India), *keatsi* (Girault, 1915a: 162) (**comb. n.** from *Scelioencyrtus*) (Australia), *laysanensis* (Timberlake, 1919b: 203) (Hawaiian Is.), *longiclavatus* (Shafee, Alam & Agarwal, 1975: 31) (India), *nigriclavus* (Girault, 1915a: 161) (Australia), *qadrii* (Shafee, Alam & Agarwal, 1975: 30) (India), *sacchari* (Alam, 1961: 239) (India), *sanguineus* (Timberlake, 1920: 416) (Hawaiian Is.), *semiflavus* (Timberlake, 1919b: 204) (Hawaiian Is.), *semiluteus* (Timberlake, 1920: 419) (Hawaiian Is.) and *tricolor* (Girault, 1915a: 162) (**comb. n.** from *Scelioencyrtus*) (Australia), also much undetermined material from throughout the region (BMNH, BPBM, DSIR, QM, ANIC, HC).

REFERENCES. Review of Hawaiian species: Timberlake (1920: 413–421); review of Indian species: Shafee *et al.* (1975: 30–36).

BIOLOGY. Parasites of Pseudococcidae (Homoptera).

COMMENTS. The species of this genus are exceedingly difficult to separate since coloration is not at all reliable. Apart from the relative lengths of the funicle segments, distribution of setae around the linea calva and in the basal cell and relative dimensions of the forewing, we have found that the position and number of the dark erect seta(e) between the posterior ocellus and eye to be of considerable use in separating the species.

Placed in the Anagyrini, subtribe Rhopina (Tetracneminae).

RHYTIDOTHORAX Ashmead

(Key couplets: 176, 216, 236, 306, 316, 331, 399, 450, 467, 530. Figs 99, 139, 415)

Rhytidothorax Ashmead, 1900b: 377. Type-species: *Rhytidothorax marlatti* Ashmead, by original designation.

Anusomyia Girault, 1915a: 164. Type-species: *Anusomyia auraticutum* Girault, by original designation.

Syn. n.

Ectromoides Girault, 1915a: 167. Type-species: *Ectromoides purpureiscutellum* Girault, by monotypy.

Syn. n.

Mesanusomyia Girault, 1922a: 48. Type-species: *Mesanusomyia fera* Girault, by monotypy. **Syn. n.**

Swazencyrtus Prinsloo & Annecke, 1979: 379. Type-species: *Swazencyrtus laticapulus* Prinsloo & Annecke, by original designation. **Syn. n.**

DISTRIBUTION AND SPECIES. Eleven species, New World, Afrotropical, Oriental, Australasian; four species from review area, all Australian: *aereiscutellum* (Girault, 1915a: 164) (**comb. n.** from *Anusomyia*), *auraticutum* (Girault, 1915a: 164) (**comb. n.** from *Anusomyia*), *ferus* (Girault, 1922a: 48) (**comb. n.** from *Mesanusomyia*) and *purpureiscutellum* (Girault, 1915a: 168) (**comb. n.** from *Ectromoides*), also many undescribed species from India, Hong Kong and the Philippines to Australia and New Caledonia (BMNH, BPBM, USNM, CNC, QM, ANIC).

BIOLOGY. Unknown.

COMMENTS. The synonymies proposed above may be difficult to accept, particularly if only the type-species of each of the five genera are examined since they appear to be very morphologically diverse (except perhaps *ferus* and *purpureiscutellum*). However, we have examined probably scores of species from all areas and find that most characters which may be used to separate genera are totally unreliable, e.g. number of teeth on the mandible (the mandibles vary from unidentate to tridentate), shape of the head, sculpture of head and dorsum of thorax, relative length of postmarginal vein of forewing and relative position of the apex of the hypopygium. All the species have these three important characters in common: a similar basic type of wing venation, relatively long propodeum and, in particular, the structure of the ovipositor. The latter is very unusual in the Encyrtinae in that the third valvulae (gonostyli) are completely fused to the second valvifers (Fig. 415) and also no part of the female genitalia is visible externally unless the ovipositor is partially or totally exerted in the egg-laying position. We believe that to keep all of these genera separate at this stage could eventually lead to the total confusion that now seems to exist in the Anagyrini (Tetracneminae) where new genera have

been described for species which do not quite fit the narrowly defined and unnatural limits of already existing genera. Furthermore we do not think that the morphological diversity of *Rhytidothorax*, as defined here, is any greater than in *Copidosoma*.

The genus is close to *Tachinaephagus* and can be separated by the structure of the ovipositor. In *Tachinaephagus* the third valvulae are free and visible externally. The two genera are probably related to *Parastenoterys* (see comments under *Parastenoterys*).

RUANDEROMA gen. n.

(Key couplet: 228, Figs 134–136, 417–421)

Type-species: *Ruanderoma sankarani* sp. n. Gender: feminine.

♀. *Head*. In facial view slightly broader than long, in profile about twice as long as broad and anteriorly more or less gradually and evenly curved. Eye with posterior margin slightly concave, slightly more than one and one-half times as long as broad, more or less naked, with extremely few short hairs and very nearly reaching occipital margin which is sharp. Malar space about one-third length of an eye, malar sulcus present. Frontovortex slightly less than half head width; ocelli in an acute angle, nearly forming a right angle, posterior ocellus about its own diameter from eye margin and about twice this from occipital margin. Antennal scrobes meeting dorsally, very short, reaching about one-fifth way from antennal toruli to anterior ocellus, sharply delimited dorsally by a transverse ridge which nearly runs from eye to eye; antennal torulus separated from mouth margin by slightly less than its own length and from other torulus by about its own length, its mid line about level with ventral margins of eyes; clypeal margin broadly and shallowly excised. Antennal scape much longer than minimum width of frontovortex, cylindrical, about seven or eight times as long as broad, pedicel conical, a little less than one-fifth length of scape, less than half as long as first funicle segment and not quite as long as sixth; funicle segments cylindrical, all longer than broad, the first the longest and gradually shortening distally; clava three-segmented, about one-quarter as long as funicle, with apex rounded but outer suture distinctly converging with inner; longitudinal sensillae on all flagellar segments. Frontovortex with numerous, deep piliferous punctures each separated by a little less than their own diameters and thus giving it a thimble-like appearance, the area between the punctures with shallow, irregular, raised reticulate sculpture, below ridge at top of antennal scrobes more regular and piliferous punctures distinct only on genae but here rather small; setae on frontovortex short, hardly longer than diameter of an ocellus. Mandible with three teeth (Fig. 136), the inner and outer ones rather short, the middle one quite long; maxillary palpus four-segmented, labial palpus three-segmented.

Thorax. In side view robust with mesoscutum and scutellum moderately convex, the metapleurum and propodeum together quite broadly in contact with the hind coxa. In dorsal view posterior margin of pronotum moderately concave, visible part of mesoscutum about two-thirds broader than long with notaular lines in anterior half, its posterior margin slightly convex; axillae meeting; scutellum a little shorter than mesoscutum with a distinct subapical carina and with its apex broadly rounded; propodeum medially about half as long as scutellum with a pair of submedian carinae between which is some very shallow irregular rugose sculpture. Mesoscutum, axillae and scutellum with irregular, very shallow, raised reticulate sculpture; dorsum of thorax with numerous inconspicuous dark brown setae. Forewing infusate with base hyaline and several wedge-shaped hyaline marks, a little over three times as long as broad; lineae calva broadly closed by several lines of setae near posterior wing margin; filum spinosum absent; submarginal vein without an apical hyaline break, slightly swollen apically; costal cell more than 30 times as long as broad, with a single line of setae dorsally in its distal one-third or so; marginal vein about 12 times as long as broad, subequal in length to postmarginal which is nearly twice as long as stigmal; submarginal vein with eight or nine very long conspicuous setae on its ventral surface at about two-thirds along its length, each seta at least three times as long as maximum diameter of submarginal vein at this point. Hindwing lightly infusate, almost hyaline, about two-thirds as long as forewing and about six times as long as broad, its marginal fringe about one-quarter to one-third wing width. Mid tibial spur about as long as basal mid tarsal segment.

Gaster. Much shorter than thorax, cercal plates about midway along its length; hypopygium reaching apex of gaster, paratergites not distinct in available slide-mounted material; last tergite slightly more than one-third as long as mid tibia, ovipositor a little less than half as long as mid tibia, gonostyli fused to second valvifers, about one-quarter as long as ovipositor.

♂. Only available male is slide-mounted, but apparently differs from female as follows. Eye clearly smaller than in female so that frontovortex distinctly more than half head width and malar space about half as long

as an eye; transverse ridge above antennal scrobes not present, or if so then not distinct; antennal torulus separated from mouth margin by about one and one-half times its own length, from other torulus by its own length, its lowest margin only slightly below lower eye margins; antennal scape slightly broader than minimum width of frontovertex, cylindrical, about five times as long as broad (may be a little less because material is slide-mounted), pedicel about one-quarter length of scape, conical, a little longer than broad but not more than half length of any funicle segment, first funicle segment longest, about six times as long as broad, sixth shortest, about three times as long as broad, clava entire, about as long as first funicle segment, setae on flagellum about as long as diameter of segments, longitudinal sensillae present on all flagellar segments but first; forewing infusate, but less strongly so than in female; aedeagus a little shorter than half length of mid tibia or about one and one-half times as long as mid tibial spur, digiti a little less than one-fifth length of aedeagus, with apical teeth present.

COMMENTS. At first glance it is not easy to place this genus in either of the recognised subfamilies of the Encyrtidae since it superficially resembles both *Callipteroma* (Tetracneminae, Anagyrini) and *Ruandella* (Encyrtinae, Microteriyini). The structure of the ovipositor, gaster and wing venation clearly point to it belonging to the Tetracneminae, but it cannot be placed in the tribe Anagyrini because of the presence of notaular lines and clearly tridentate mandibles. The presence of notaular lines, ovipositor structure and apparent absence of paratergites suggest that the genus can be best placed in the Charitopidini although it is somewhat out of place here, having strongly infusate forewings and different venation.

The type-species of the genus is named in honour of Dr T. Sankaran (Commonwealth Institute of Biological Control, Bangalore, India).

Ruanderoma sankarani sp. n.

(Figs 134–136, 417–421)

♀. Length: 1.31–1.57 mm (holotype, 1.57 mm).

Colour. Holotype with head dark metallic green, between punctures with weak purple reflections; scape testaceous yellow, pedicel and flagellum dark brown; pronotum, sides and venter of thorax dark orange-brown, mesoscutum, scutellum and axillae dark brown with green, blue and brassy reflections; forewing infusate with pattern as in Fig. 134; legs orange with fore and mid coxae brown, mid tibia a little paler than mid femur, hind femur and tibia which are a little brownish; gaster dark brown with purple and brassy reflections, basal segment orange. There is some variation in colour: the purple colour between the piliferous punctures of the frontovertex can be quite strong and one paratype has the thorax mostly orange (including coxae) with only the mid line of the mesoscutum slightly metallic, the axillae and scutellum with weak purple reflections, the head of this specimen is less strongly metallic green with a hint of orange, the lower parts of the face being distinctly orange.

Head. Relative measurements (holotype): head length 36, head width (facial view) 41, head width (side view) 18, minimum frontovertex width 18, malar space 9, eye length 28.5, eye width 17, POL 12, OOL 2, scape length 25, scape width 3, other proportions of antenna as in Fig. 420. Mandible as in Fig. 136.

Thorax (Fig. 135). Relative measurements (holotype): forewing length 112, other proportions of forewing as in Fig. 134; hindwing length 82, hindwing width 13.

Gaster. Relative lengths (paratype): last tergite 60, ovipositor 76, gonostyli 16, [mid tibia 166]; genitalia as in Fig. 417.

♂. Length: approx. 1.33 mm. Generally differs from female in structure of antenna (Fig. 421), size of eye and genitalia (Figs 418, 419). Relative measurements (paratype): head width 78, minimum frontovertex width 45, scape length 40, aedeagus length 42, mid tibia 103, mid tibial spur 27.

DISTRIBUTION. India.

BIOLOGY. Unknown.

MATERIAL EXAMINED

Holotype ♀, **India:** Karnataka, 25 km W. of Mudigere, 28.x–3.xi.1979 (*J. S. Noyes*) (BMNH).

Paratypes. **India:** 2 ♀, same data as holotype; 1 ♀, Bangalore, iii.1979 (*T. Sankaran*); 1 ♂, Himachal Pradesh, Manali, Bilaspur, 13.x.1979 (*Z. Bouček*) (BMNH).

RUSKINIANA Girault

(Key couplet: 97)

Ruskiniana Girault, 1923e: 5. Type-species: *Ruskiniana sexguttatipennis* Girault, by monotypy.

DISTRIBUTION AND SPECIES. One species, Australia only: *sexguttatipennis* (1923e: 5), also one further species from Australia (BMNH).

BIOLOGY. Unknown.

COMMENTS. Girault described this genus and species from at least two specimens, both of which appear to have been lost. However, three specimens (BMNH) agree totally with Girault's brief description and our interpretation of the genus is based on these.

Ruskiniana belongs to the Habrolepidini, subtribe Habrolepidina (Encyrtinae). It is extremely close to *Habrolepis* and virtually can only be separated by the number of scale-like setae at the apex of the scutellum (see key). Very probably they should be synonymised.

SAKENCYRTUS Hayat

(Key couplets: 76, 385. Figs 33, 195, 196, 422–426)

Sakencyrtus Hayat, 1981b: 27. Type-species: *Sakencyrtus mirus* Hayat, by original designation.

DISTRIBUTION AND SPECIES. One species, India only: *mirus* Hayat (1981b: 28), also at least two undescribed species from India, Fiji (?) and Australia (BMNH, BPBM).

BIOLOGY. Unknown.

COMMENTS. The genus is close to *Mira* (see comments under *Mira*).

SAPRENCYRTUS gen. n.

(Key couplets: 234, 462. Figs 141, 221, 222, 427)

Type-species: *Parasyrphophagus casuarinae* Girault. Gender: masculine.

♀. *Head*. In frontal view a little wider than long, in side view about twice as long as broad and more or less gradually and evenly anteriorly rounded. Eye more or less naked but with a few, sparse, inconspicuous setae each no longer than the diameter of a facet; posterior margin of eye more or less straight, eye about one-half longer than broad and more or less reaching occipital margin which is moderately acute. Malar space about two-thirds length of an eye with sulcus absent but marked by a slight change of sculpture. Frontovortex slightly more than one-third head width; ocelli more or less forming a right angle, the posterior ones nearly touching eye margin but separated from occipital margin by clearly more than their own major diameters. Antennal scrobes shallow, semicircular, meeting dorsally and reaching about one-third way from antennal toruli to anterior ocellus; antennal torulus separated from mouth margin by about its own length and from other torulus by about one-third more than its own length, its dorsal margin a little below ventral level of eyes; clypeus shallowly emarginate. Antennal scape clearly longer than width of frontovortex, slightly flattened, about five times as long as broad; pedicel conical, a little less than one-third as long as the scape and clearly shorter than the first funicle segment; all funicle segments cylindrical, longer than broad, clearly becoming broader and shorter distally so that the sixth is very nearly quadrate; clava three-segmented, less than one-third length of funicle, with apex more or less rounded and sutures more or less parallel; longitudinal sensillae on all flagellar segments except perhaps the first; longest setae a little shorter than diameter of first funicle segment. Frontovortex with fine, shallow, raised, reticulate sculpture, more longitudinally elongate between eyes and antennal scrobes, interantennal prominence almost smooth; setae on frontovortex sparse, each not longer than diameter of anterior ocellus. Mandible with three teeth; maxillary palpus four-segmented, labial palpus three-segmented.

Thorax. In side view moderately deep with both mesoscutum and scutellum only a little convex, metapleurum and propodeum together broadly in contact with hind coxa. Pronotum in dorsal view with posterior margin broadly concave; visible part of mesoscutum about one-third broader than long, notaular lines absent, its posterior margin slightly convex but not projecting above axillae which meet medially; scutellum fairly convex, nearly one-third longer than broad, apically quite pointed; propodeum medially only a little less than one-fifth length of scutellum. Mesoscutum with shallow, raised, reticulate sculpture,

scutellum similar but conspicuously shallower and smoother, propodeum medially with similar sculpture to posterior part of scutellum but otherwise fairly smooth; mesopleurum with irregular, shallow, raised, reticulate sculpture in anterior one-third, medially and posteriorly becoming smoother and alutaceous; mesoscutum and scutellum with a few sparse short setae; a few translucent setae on propodeum in front of and to the outside of the spiracle. Forewing infusate, about two and one-half to nearly three times as long as broad; linea calva not interrupted or closed; basal cell moderately hairy but naked proximally; some setae on proximal side of linea calva opposite filum spinosum flattened and scale-like as are some below marginal vein; submarginal vein with parastigma hardly swollen and with a subapical hyaline break; costal cell about 15 times as long as broad, with a few setae dorsally apically; marginal vein about five times as long as broad, about two-thirds longer than stigmal and twice as long as postmarginal. Hindwing hyaline. Mid tibial spur slightly shorter than mid basal tarsal segment.

Gaster. About one-quarter longer than thorax (including propodeum), acute apically; hypopygium with apex at about one-third along gaster; last tergite about three-quarters as long as gaster or a little longer than mid tibia; ovipositor slightly exerted, the exerted part about one-tenth length of gaster and sheaths slightly flattened from side to side.

♂. Not available for description.

COMMENTS. This genus may possibly belong near *Pseudencyrtus* Ashmead (Microteryni, subtribe Pseudencyrtina). This is suggested by the association with galls, the extremely long gaster and the elongate last gastral tergite. However, the venation is more similar to that of *Syrphophagus*. The genus can be distinguished from these and related genera principally by the strongly infusate forewing and presence of scale-like setae on the proximal side of the linea calva opposite the filum spinosum.

***Saprenicyrtus casuarinae* (Girault) comb. n.**

(Figs 141, 221, 222, 427)

Parasyrphophagus casuarinae Girault, 1934b: 3. LECTOTYPE ♀, AUSTRALIA (QM), here designated [examined].

♀. Length: 2.85–3.24 mm (lectotype, 2.85 mm).

Colour. Head dark metallic greenish blue, mesoscutum metallic green, scutellum metallic blue with some green reflections, mesopleurum, propodeum and gaster purplish, base of gaster more shiny; antenna with scape dark brownish and with a slight metallic green sheen, funicle segments dark brown, apex of fifth, whole of sixth and clava yellowish; legs, including coxae, dark brown, femora and tibiae very slightly brassy or metallic green; forewing infusate as in Fig. 141.

Head. Mandible as in Fig. 221. Relative measurements (paralectotype): head length 114, head width (frontal view) 123, head width (side view) 57, minimum frontovertex width 35, POL, 21, OOL 1.5, malar space 49, eye length 71, eye width 51, scape length 72, other proportions of antenna as in Fig. 427. Girault, in his description of the species, states that funicle segments five and six are one-half longer than wide, but this conflicts with the intact specimen described here and the antenna figured. This may result from Girault describing the antenna from a poorly mounted specimen on a slide.

Thorax. Relative measurements (paralectotype): forewing length 343, forewing width 129. Base of forewing as in Fig. 222.

Gaster. Relative lengths (paralectotype): last tergite 176, [mid tibia 150].

♂. Not available for description.

DISTRIBUTION. Australia.

BIOLOGY. Parasites or inquilines in galls of *Cylindrococcus amplior* Maskell (Homoptera, Eriococcidae) on *Casuarina stricta*.

MATERIAL EXAMINED

Lectotype ♀, **Australia**: South Australia, Adelaide, from gall of *Cylindrococcus amplior* on *Casuarina stricta*, 5.vii.1932 (J. B. Cleland).

Australia: 2 ♀ (paralectotypes), South Australia, Adelaide, from gall of *Cylindrococcus amplior* on *Casuarina stricta*, 5.vii.1932 (J. B. Cleland) (one lacking head). (The collector's name conflicts with that given by Girault (1934b: 3), i.e. A. L. Tonnoir.)

COMMENTS. Although the genus and species is described here from two female syntypes, all the syntypes were examined during a visit to the Queensland Museum, Brisbane. In his unpublished manuscript (QM), Girault states that the species was described from one male and four females. A specimen on loan from ANIC, Canberra in QM, Brisbane is here designated lectotype and labelled as such by one of us (JSN).

SCHILLERIELLA Ghesquière

(Key couplet: 76)

Schilleria Girault, 1932a: 1. Type-species: *Schilleria pulchra* Girault, by monotypy. [Homonym of *Schilleria* Dahl, 1907.]

Schilleriella Ghesquière, 1946: 369. [Replacement name for *Schilleria* Girault.]

DISTRIBUTION AND SPECIES. One species, Australia only: *pulchra* (Girault, 1932a: 1).

BIOLOGY. Unknown.

COMMENTS. *Schilleriella* appears to be related to *Anusia* Förster (tribe Anagyrini, subtribe Anusiina).

SPANIOPTERUS Gahan

(Key couplet: 53. Figs 19, 20)

Spaniopterus Gahan, 1927b: 149. Type-species: *Spaniopterus crucifer* Gahan, by original designation.

DISTRIBUTION AND SPECIES. One species, Java and Malaysia only: *crucifer* Gahan (1927b: 150).

BIOLOGY. Parasites of Diaspididae (Homoptera).

COMMENTS. Placed in the tribe Habrolepidini, subtribe Comperiellina (Encyrtinae). It can be distinguished from *Comperiella* by having a four-segmented funicle (*Comperiella* has a six-segmented funicle).

STENOTEROPSIS Girault

(Key couplet: 530)

Stenoteropsis Girault, 1915a: 176. Type-species: *Stenoteropsis abjectus* Girault, by original designation.

DISTRIBUTION AND SPECIES. One species, Australia only: *abjectus* Girault (1915a: 176).

BIOLOGY. Unknown.

COMMENTS. Probably related to *Helegonatopus* (Chalcerinyini), from which it can be separated by having the ovipositor slightly exserted and the sheaths a little swollen apically. The two genera may be synonymous, but we are retaining *Stenoteropsis* as valid until fresh material can be compared with the holotype of *abjectus*, which is in poor condition.

SYRPHOPHAGUS Ashmead

(Key couplets: 289, 301, 341, 343, 349, 398, 455, 526. Fig. 186)

Syrphophagus Ashmead, 1900b: 397. Type-species: *Encyrtus mesograptae* Ashmead, by original designation.

Aphidencyrtus Ashmead, 1900b: 398. Type-species: *Encyrtus aphidiphagus* Ashmead, by original designation. **Syn. n.**

Echthrobaccha Perkins, 1906: 253. Type-species: *Echthrobaccha injuriosa* Perkins, by monotypy.

Nesyrrhophagus Girault, 1915a: 113. Type-species: *Nesyrrhophagus flavithorax* Girault, by original designation. **Syn. n.**

Hexanusia Girault, 1922a: 39. Type-species: *Hexanusia nigricornis* Girault, by monotypy. **Syn. n.**

Syrphidencyrtus Blanchard, 1940: 107. Type-species: *Syrphidencyrtus bacchae* Blanchard, by monotypy.

DISTRIBUTION AND SPECIES. About 60 species, cosmopolitan; 22 from review area: *aeruginosus* (Dalman, 1820: 170) (India, Hawaiian Is.), *aphidivorus* (Mayr, 1876: 712, 713, 714) (**comb. n.** from *Encyrtus*) (India, Hawaiian Is.), *aquacyaneus* (Girault, 1923a: 50) (**comb. n.** from *Coccidoxenus*) (Australia), *cinctipes* (Girault, 1915a: 110) (**comb. n.** from *Neasteropaeus*) (Australia), *feralis* (Girault, 1929b: 315) (**comb. n.** from *Paraenasomyia*) (Australia), *flavithorax* (Girault, 1915a: 113) (**comb. n.** from *Nesyropophagus*) (= *Nesyropophagus unguittatus* Girault, 1915a: 113 **syn. n.**, = *Hexanusia sanguinithorax* Girault, 1927b: 310 **syn. n.**) (Australia), *hakki* Agarwal (1962a: 248) (India), *hofferi* (Hayat, 1973: 35) (**comb. n.** from *Aphidencyrtus*) (India), *indicus* Agarwal (1962a: 246) (India), *injurius* (Perkins, 1906: 254) (Australia), *kumaoensis* (Bhatnagar, 1952: 163) (**comb. n.** from *Coccidencyrtus*) (India), *luciani* (Girault, 1922a: 42) (**comb. n.** from *Echthrobaccha*) (Australia), *merceti* (Masi, 1926: 268) (**comb. n.** from *Microterys*) (Taiwan), *metallicus* (Girault, 1914a: 33) (**comb. n.** from *Aratus*) (Australia), *nigricornis* (Girault, 1922a: 39) (**comb. n.** from *Hexanusia*) (Australia), *obscurus* (Girault, 1923c: 143) (**comb. n.** from *Neasteropaeus*) (Australia), *occidentalis* (Girault, 1917e: 95) (**comb. n.** from *Cerchysius*) (Australia), *parvus* (Girault, 1923a: 47) (**comb. n.** from *Cerchysiopsis*) (Australia), *perdubius* (Girault, 1926c: 132) (**comb. n.** from *Coccidoxenus*), *puparia* (Girault, 1929b: 313) (**comb. n.** from *Epiblatticida*) (Australia), *raffaellini* (Girault, 1922d: 208) (**comb. n.** from *Habrolepoidea*) (Australia) and *varicornis* (Girault, 1923c: 143) (**comb. n.** from *Neasteropaeus*) (Australia), also much undetermined material from throughout the region (BMNH, BPBM, QM, ANIC, USNM, HC, GC).

BIOLOGY. Parasites of Aphididae (primary or secondary), Psyllidae (Homoptera) and larvae of Diptera, mostly of Syrphidae predatory on aphids.

COMMENTS. The apparent difference in biologies of *Syrphophagus* and *Aphidencyrtus* have been virtually the only reason for regarding both genera as valid, the two being difficult to separate reliably on morphology alone (see Trjapitzin, 1972). One Australian species, *nigricornis* (Girault), would be considered a typical species of *Syrphophagus* by most encyrtid taxonomists since morphologically it is very close to *aeruginosus* (Dalman). However, this species is regularly reared from aphids! With this in mind, the ecological closeness of their hosts and the difficulty in assigning many species to either genus without knowledge of their biologies, we here regard the two as synonymous. Consequently, in addition to the above, we also propose the following new combinations for extra-limital species known to us: *africanus* Gahan (from *Aphidencyrtus*), *cassatus* Annecke (from *Aphidencyrtus*), *inquisitor* Howard (from *Encyrtus*), *mamitus* Walker (from *Encyrtus*), *quercicola* Hoffer (from *Aphidencyrtus*), *similis* Prinsloo (from *Aphidencyrtus*), *tachikawai* Hoffer (from *Aphidencyrtus*) and *taeniatus* Förster (from *Encyrtus*) (all *Syrphophagus*, **comb. n.**).

The holotype of *Microterys merceti* Masi has been examined (IPK). It belongs to *Syrphophagus*.

We have not seen the holotype of *Coccidencyrtus kumaoensis* Bhatnagar, but from the description it must be a *Syrphophagus*.

The genus is placed in the Microterysiini, subtribe Syrphophagina (Encyrtinae) (see comments under *Coccidoctonus*).

SZELENYIOLA Trjapitzin

(Key couplet: 182)

Szelenyiola Trjapitzin, 1977: 160. Type-species: *Szelenyiola nearctica* Trjapitzin, by original designation.

DISTRIBUTION AND SPECIES. Two described species, New World and Australia: *prospheris* (Ferrière, 1947: 629) (**comb. n.** from *Ooencyrtus*) (Australia).

BIOLOGY. Parasites of eggs of Buprestidae and Scolytidae (Coleoptera).

COMMENTS. Ferrière (1947) described the clava of *prospheris* as being three-segmented, but examination of slide-mounted material shows that it is entire.

Placed in the tribe Microteryini, subtribe Oobiina (Encyrtinae). Trjapitzin (1977) provides a key to separate the genera of this subtribe.

TACHARDIAEPHAGUS Ashmead

(Key couplets: 308, 392, 409. Figs 184, 185)

Tachardiaephagus Ashmead, 1904c: 503. Type-species: *Tachardiaephagus thoracicus* Ashmead, by original designation.

Lissencyrtus Cameron, 1913: 99. Type-species: *Lissencyrtus troupi* Cameron, by monotypy.

DISTRIBUTION AND SPECIES. Four species, Afrotropical, Oriental, Australasian; one from review area: *tachardiae* (Howard in Howard & Ashmead, 1896: 637) (India, Sri Lanka, Malaysia, Brunei), also undetermined material from Taiwan and the Philippines (BPBM).

REFERENCE. Prinsloo (1977: 57–69).

BIOLOGY. Parasites of Keriidae (Homoptera).

COMMENTS. Placed in the tribe Microteryini, subtribe Microteryina (Encyrtinae), it can be easily distinguished from other genera found in review area by the structure and shape of the antennal scrobes (Figs 184, 185).

TACHINAEPHAGUS Ashmead

(Key couplets: 236, 306, 316, 365, 399, 450. Figs 143, 144, 236, 428, 430)

Tachinaephagus Ashmead, 1904c: 304. Type-species: *Tachinaephagus zealandicus* Ashmead, by original designation.

Phaenodiscoides Girault, 1915a: 82. Type-species: *Phaenodiscoides australiensis* Girault, by original designation. **Syn. n.**

Tachinacphagus Girault, 1917g: 142. Type-species: *Tachinacphagus australiensis* Girault, by original designation.

Australencyrtus Johnson & Tieg, 1921: 118. Type-species *Australencyrtus giraulti* Johnson & Tieg, by original designation.

Australomalotylus Risbec, 1956: 170. Type-species: *Australomalotylus rageaui* Risbec, by monotypy.

DISTRIBUTION AND SPECIES. Ten species, Afrotropical, east Palaearctic, Oriental and Australasian; seven from review area: *australiensis* (Girault, 1914b: 59) (**comb. n.** from *Phaenodiscus*) (= *Phaenodiscoides australiensis* Girault, 1915a: 82 **syn. n.**) (Australia), *ceylonicus* (Subba Rao, 1972: 191) (Sri Lanka), *jayensis* Subba Rao (1978: 71) (Indonesia), *lutheri* (Girault, 1924a: 6) (**comb. n.** from *Phaenodiscoides*) (Australia), *lyperosae* (Ferrière, 1933: 638) (**comb. n.** from *Cerchysius*) (Java), *malayensis* Subba Rao (1978: 72) (Malaysia) and *zealandicus* Ashmead (1904c: 304) (Australia, New Caledonia, New Zealand), also many undescribed species amongst material from India and S. China to Australia and Fiji (BMNH, BPBM, USNM, CNC).

REFERENCE. Revision: Subba Rao (1978).

BIOLOGY. Parasites of larvae of Calliphoridae, Muscidae, Sarcophagidae and Tephritidae (Diptera).

COMMENTS. Girault inadvertently described the same specimen twice as *australiensis*, once under *Phaenodiscus* and once under *Phaenodiscoides*. This is evident from a comparison of the original descriptions. We do not consider *Phaenodiscoides* as a valid genus since *australiensis* is fairly typical of *Tachinaephagus* except that the antennae are a little longer than in most species included in this genus.

We have examined a paratype of *Cerchysius lyperosae* Ferrière (BMNH); it is a species of *Tachinaephagus* with a well-exserted ovipositor.

The genus is related to *Rhytidothorax*, *Parastenoterys* (see comments under these genera) and

Nerissa Trjapitzin (1977: 165). The last is very close and may eventually be considered synonymous with *Tachinaephagus*, differing only very slightly in the venation of the forewing.

TAFTIA Ashmead

(Key couplets: 402, 427. Figs 211, 212)

Taftia Ashmead, 1904d: 137. Type-species: *Taftia prodeniae* Ashmead, by original designation.

DISTRIBUTION AND SPECIES. Two species, Philippines and Java only: *prodeniae* Ashmead (1904d: 137) (Philippines) and *saissetiae* Gahan (1920: 344) (Philippines, Java), also one further species from Malaysia (BPBM).

BIOLOGY. Parasites of Pseudococcidae (Homoptera).

COMMENTS. Placed in the Chrysoplatycerini, subtribe Taftiina (Tetracneminae) which also includes *Lutherisca* from which it can be separated using the characters given in the key. In all probability Taftiina should be considered synonymous with Chrysoplatycerina.

TASSONIA Girault

(Key couplet: 515. Fig. 252)

Tassonia Girault, 1921a: 2. Type-species: *Tassonia gloriae* Girault, by monotypy.

DISTRIBUTION AND SPECIES. Two species, Oriental and Australasian only: *gloriae* Girault (1921a: 2) (= *Neblatticida tassoniaeformis* Girault, 1921a: **syn. n.**) (Australia) and *magniclava* (Hayat & Subba Rao, 1981: 108) (**comb. n.** from *Aphidencyrtus*) (India), also further material containing several undescribed species from India, Hong Kong, Malaysia and Java (BMNH, BPBM, UCR).

BIOLOGY. Parasites of Aphididae (Homoptera).

COMMENTS. The genus is related to *Syrphophagus* (Microteriyini, subtribe Syrphophagina). It differs in several characters, notably in its generally smaller size, more convex thoracic dorsum, shorter clavate antenna, thicker and subequal marginal, postmarginal and stigmal veins of the forewing and the presence of a naked streak joining the apex of the postmarginal vein to the stigmal (Fig. 252).

TELETEREBRATUS Compere & Zinna

(Key couplets: 199, 369. Figs 431, 432)

Teleterebratus Compere & Zinna, 1955: 108. Type-species: *Teleterebratus perversus* Compere & Zinna, by original designation.

DISTRIBUTION AND SPECIES. Three species, Oriental and Australasian only: *amplis* (Girault, 1915a: 81) (**comb. n.** from *Aenasiella*) (Australia), *claripennis* (Girault, 1915a: 101) (**comb. n.** from *Rhopalencyrtoidea*) (Australia) and *perversus* Compere & Zinna (1955: 110) (China).

BIOLOGY. Parasites of Diaspididae and gall-forming Eriococcidae (Homoptera).

COMMENTS. We have not seen the types of *Ageniaspis indicus* Narayanan, but from the very poor description the species possibly belongs in *Teleterebratus*.

The genus appears to be related to *Coccidoctonus* (see comments under *Coccidoctonus*).

TETRACNEMOIDEA Howard

(Key couplet: 53. Figs 21, 22)

Tetracnemoidea Howard, 1898b: 232. Type-species: *Tetracnemoidea australiensis* Howard, by monotypy. *Tetracnemopsis* Ashmead, 1900a: 358. Type-species: *Tetracnemus westwoodii* Cockerell, by original designation.

Ectromella Girault, 1915a: 142. Type-species: *Ectromella bicolor* Girault, by original designation. **Syn. n.**
Arhopoideus Girault, 1915a: 174. Type-species: *Arhopoideus brevicornis* Girault, by original designation.
Hungariella Erdős, 1946b: 144. Type-species: *Hungariella piceae* Erdős, by original designation.
Antipodencyrtus Kerrich, 1964b: 505. Type-species: *Antipodencyrtus procellosus* Kerrich, by monotypy.
Syn. n.

DISTRIBUTION AND SPECIES. Sixteen species, cosmopolitan; nine from review area: *australiensis* Howard (1898b: 232) (Australia), *bicolor* (Girault, 1915a: 142) (**comb. n.** from *Ectromella*) (= *Arhopoideus tertius* Girault, 1923c: 144 **syn. n.**) (Australia), *brevicornis* (Girault; Tachikawa, 1974: 23) (Australia), *brouni* (Timberlake, 1929: 6) (New Zealand), *indica* (Ayyar, 1932: 287) (India), *ipswichia* (Girault, 1922f: 1) (Australia), *procellosa* (Kerrich, 1964b: 505) (**comb. n.** from *Antipodencyrtus*) (New Zealand) and *secunda* (Girault, 1915a: 175) (Australia), also undetermined material, containing several undescribed species from Papua New Guinea, Tonga, Australia and New Zealand (BMNH, BPBM, DSIR, QM, ANIC).

REFERENCE. World review: Trjapitzin & Gordh (1980a).

BIOLOGY. Parasites of Pseudococcidae (Homoptera).

COMMENTS. Recent collecting in New Zealand has revealed a wealth of material belonging to this genus, including winged forms of *procellosus* or a very similar species. We do not think that the slightly flattened body, or the difference in the number of branches in the antenna of the male, are sufficient reasons for regarding *Antipodencyrtus* as distinct from *Tetracnemoidea*.

Placed in the tribe Tetracneminae, subtribe Arhopoideina (Tetracneminae).

TETRACNEMUS Westwood

(Key couplet: 361)

Tetracnemus Westwood, 1837: 258. Type-species: *Tetracnemus diversicornis* Westwood, by monotypy.
Tetracladia Howard, 1892: 367. Type-species: *Tetracladia texana* Howard, by designation of Ashmead (1900: 358).
Tetralophidea Ashmead, 1900b: 348. Type-species: *Tetralophidea bakeri* Ashmead, by original designation.
Tetralophiellus Ashmead, 1900b: 357. Type-species: *Tetralophiellus brevicollis* Ashmead, by original designation.
Paracalocerinus Girault, 1915a: 142. Type-species: *Paracalocerinus australiensis* Girault, by original designation.
Masia Mercet, 1919b: 470. Type-species: *Masia bifasciatella* Mercet, by original designation.
Anusiella Mercet, 1923a: 287. Type-species: *Anusia heydeni* Mayr, by original designation.
Placocerus Erdős, 1946a: 1. Type-species: *Placocerus calocense* Erdős, by monotypy.
Comperencyrtus De Santis, 1964: 106. Type-species: *Comperencyrtus maculipennis* De Santis, by original designation.

DISTRIBUTION AND SPECIES. Twenty-one species, cosmopolitan; five from review area: *australiensis* (Girault, 1915a: 142) (Australia), *deccanensis* (Mani & Kaul in Mani *et al.*, 1974: 65) (India), *diversicornis* Westwood (= *Masia pulchripennis* Mercet, 1923a: 289) (India), *heterocornis* Mani & Saraswat in Mani *et al.*, 1974: 75) (India) and *peninsularis* (Mani & Saraswat in Mani *et al.*, 1974: 73), also several undetermined species from India and Australia (BMNH, ANIC, QM, HC).

BIOLOGY. Parasites of Pseudococcidae (Homoptera).

COMMENTS. Placed in the Tetracnemini, subtribe Tetracnemina (Tetracneminae). The genus can be easily recognised by the well-exserted ovipositor, darkened forewings with a relatively long marginal and short postmarginal and stigmal veins, and the very flattened antennal flagellum.

THOMSONISCA Ghesquière

(Key couplet: 191. Figs 114, 429)

Thomsoniella Mercet, 1921: 89. Type-species: *Thomsoniella typica* Mercet, by original designation. [Homonym of *Thomsoniella* Signoret, 1880.]

Thomsonisca Ghesquière, 1946: 369. [Replacement name for *Thomsoniella* Mercet.]

Heterencyrtus Hoffer, 1953: 86. Type-species: *Heterencyrtus sumavicus* Hoffer, by original designation.

Athesmus Erdős & Nowicky, 1955: 198. Type-species: *Athesmus luctuosus* Erdős & Nowicky, by original designation.

Kosztarabia Erdős, 1957b: 367. Type-species: *Kosztarabia chionaspidis* Erdős, by original designation.

Euussuria Chumakova, 1957: 539. Type-species: *Euussuria pallipes* Chumakova, by original designation.

Pakencyrtus Ahmad, 1970: 237. Type-species: *Pakencyrtus pakistanensis* Ahmad, by original designation.

DISTRIBUTION AND SPECIES. Six species, Palaearctic, Oriental; four from review area: *amathus* (Walker; = *Thomsoniella typica* Mercet, 1921: 90), *indica* Hayat (1970b: 55) (India), *pakistanensis* (Ahmad, 1970: 238) (India, Pakistan) and *sankarani* Subba Rao (1979: 142) (India).

REFERENCE. Review: Subba Rao (1979: 139–144).

BIOLOGY. Parasites of Diaspididae (Homoptera).

COMMENTS. Placed in the tribe Thomsoniscini (Encyrtinae).

TINEOPHOCTONUS Ashmead

(Key couplet: 357)

Tineophoctonus Ashmead, 1900b: 351. Type-species: *Phaenodiscus armatus* Ashmead, by original designation.

DISTRIBUTION AND SPECIES. Three species, New World, Europe, and one undescribed species from Papua New Guinea (BPBM).

BIOLOGY. Parasites of gall-inhabiting Tineidae (Lepidoptera), Cynipidae (Hymenoptera) and larvae of Anobiidae and Cerambycidae (Coleoptera).

COMMENTS. The species from Papua New Guinea may be incorrectly placed in *Tineophoctonus* since the antennal clava is obliquely truncate and the funicle segments are relatively shorter than in the described species. However, in other characters it seems to comply with those of *Tineophoctonus*.

Placed in the tribe Cheiloneurini (Encyrtinae) and closest to *Cheiloneurus* and *Prochiloneurus*. It can be separated from *Cheiloneurus* by the hypopygium reaching the apex of the gaster and from *Prochiloneurus* by the gaster being apically acute.

TONGYUS gen. n.

(Key couplet: 150. Figs 81, 433–439)

Type-species: *Tongyus nesus* sp. n. Gender: masculine.

♀. *Head.* In facial view slightly broader than long, in profile slightly less than twice as long as broad and anteriorly gradually and more or less evenly curved except along length of antennal scrobes where it is almost straight. Eye with posterior margin a little concave, almost straight, about one-third longer than broad, covered with fairly dense long hairs, each hair about one and one-half times to twice as long as diameter of a facet, eye reaching occipital margin which is sharp. Malar space about one-third eye-length, sulcus present. Frontoververtex about one-third head width; ocelli nearly forming an equilateral triangle, the posterior ones a little nearer eye margin than occipital margin and separated from the latter by about their own major diameters. Antennal scrobes moderately deep and meeting dorsally or separated by interantennal prominence which is confluent with frontoververtex, reaching about half way from antennal toruli to anterior ocellus; antennal torulus separated from mouth margin by not more than two-thirds its own length and from other torulus by slightly more than about one-half its own length, its dorsal margin about level

with or a little above the lowest eye margin; clypeal margin shallowly excised. Antennal scape broadened and flattened, a little more than twice as long as broad and clearly longer than minimum width of frontovertex; pedicel conical, slightly longer than any funicle segment except perhaps the first; all funicle segments longer than broad, the sixth only slightly so; clava three-segmented, apically rounded, but with outer suture slightly oblique and converging with inner; flagellar segments slightly flattened, subcylindrical; longitudinal sensillae on all flagellar segments, longest setae clearly shorter than diameter of segments. Frontovortex with very fine, raised, moderately deep, squamiform-reticulate sculpture (Fig. 436), with scattered inconspicuous, translucent setae; eye margins with fairly conspicuous dark setae. Mandible narrow with two acute apical teeth; maxillary palpus four-segmented, labial palpus three-segmented.

Thorax. In side view moderately deep, with mesoscutum and scutellum very slightly convex, the metapleurum and propodeum together narrowly in contact with hind coxa. In dorsal view pronotum with hind margin slightly concave; visible part of mesoscutum about twice as broad as long, notaular lines absent posterior margin very clearly convex and produced backwards above axillae; axillae meeting medially; scutellum about as long as mesoscutum, about as broad as long, with apex more or less pointed, sides straight; propodeum medially short, not more than about one-ninth as long as scutellum. Mesoscutum with sculpture similar to but clearly shallower than that on frontovertex; scutellum with same sculpture as frontovertex; propodeum medially with very shallow, irregular, rugose sculpture, outside spiracles much deeper and irregular, mesopleurum with shallow, very fine, raised, regular, reticulate sculpture; setae on dorsum of thorax fairly dense, translucent or brown, quite conspicuous, particularly on scutellum. Forewing at least partially infuscate, about two and one-half times as long as broad; lineae calva closed in posterior one-third; filum spinosum absent; submarginal vein with an apical hyaline break, parastigma not swollen; costal cell about 14 times as long as broad, with a single line of setae dorsally in its apical one-third; marginal vein about three or four times as long as broad, clearly shorter than stigmal which is as long as or a little longer than postmarginal. Hindwing about two-thirds length of forewing, about four times as long as broad, marginal fringe about one-ninth as long as maximum wing width. Mid tibial spur a little shorter than basal mid tarsal segment.

Gaster. About as long as thorax; cercal plates in basal one-half; hypopygium reaching apex of gaster; paratergites present; last tergite slightly shorter than mid tibia; ovipositor hardly exerted, about three-quarters as long as mid tibia; gonostyli fused to second valvifers, about one-eighth as long as ovipositor.

♂. Similar to female except body generally darker, antenna and genitalia. Differs as follows. Head proportionately a little broader in frontal view; malar space about one-half length of eye; frontovertex nearly half head width; ocelli nearly forming a right angle, the posterior ones almost equidistant from occipital margin and eye, although a little closer to the former; antennal toruli separated from mouth margin by much more than their own lengths, their lowest margins a little below lowest eye margins; antennal scape shorter than minimum width of frontovertex, stout and slightly broadened and flattened, a little less than three times as long as broad; pedicel conical, subquadrate, not more than half as long as any funicle segment all of which are cylindrical and beset with long setae, the longest at least about four times as long as diameter of segments; clava entire and gradually tapering to a point; longitudinal sensillae on all flagellar segments; scale like sensillae on clava only. Forewing a little broader than in female; lineae calva interrupted and closed. Genitalia with aedeagus slightly less than half as long as mid tibia, digiti (excluding apical spines) about one-fifth as long as aedeagus, each with a pair of long apical spines.

COMMENTS. *Tongyus* belongs in the Anagyrini, subtribe Anagyrina (Tetracneminae) and appears to be most closely related to *Anagyrus*. In the female it can be separated from this and other genera of this group by the combination of the slightly flattened flagellar segments, converging sutures of the clava, sculpture of the head and dorsum of thorax, infuscation of forewings and wing venation.

Tongyus nesus sp. n.

(Figs 81, 433–439)

♀. Length: 1.11–1.75 mm (holotype, 1.60 mm).

Colour. Head and thorax brownish yellow, with scutellum, metanotum and propodeum largely dark brown, gaster dark brown; antenna with scape more or less white but margined dark brown ventrally and dorsally (Fig. 433), pedicel and flagellum dark brown; legs brownish yellow but mixed with dark brown, especially apex of mid tibia and all of hind femur and tibia, hind coxa dark brown; forewing infuscate from

base to about one-quarter along wing, an indistinct and incomplete fuscous fascia across wing from marginal and stigmal veins (Fig. 81), remainder of forewing and hindwing hyaline.

Head. Antennal scrobes meeting dorsally, interantennal prominence at its upper level clothed in numerous, fairly dense, white setae which continue down either side of prominence to mouth margin. Relative measurements (holotype): head length 35, head width (facial view) 40, head width (side view) 18, minimum frontovertex width 14, malar space 8, eye length 25, eye width 19, POL 5·5, OOL 2·5, scape length 22, scape width 10, proportions of antenna as in Fig. 433.

Thorax. Mesoscutum anteriorly with dark setae, posteriorly, and axillae, with translucent or pale setae, usually one or two dark setae scattered amongst pale setae, scutellum with dark setae. Relative measurements (holotype): forewing length 105, width 40, proportions of veins as in Fig. 81; hindwing length 69, width 18. Basal cell of forewing with setae evenly distributed and as dense as in disc distal to venation.

Gaster. Relative lengths (paratype): last tergite 47, ovipositor 40, [mid tibia 55]; genitalia as in Fig. 434, hypopygium as in Fig. 435.

♂. Length: 0·96–1·30 mm. Similar to female except following. Body completely dark brown except for interantennal prominence and lower part of face below and to outside of antennal toruli, which are brownish yellow; outer part of scape at base brownish yellow, remainder of antenna dark brown; prepectus whitish; legs dark brown except fore femur and tibia, base of mid tibia and all tarsi which are testaceous yellow, four apical tarsal segments of mid leg mixed dark brown, occasionally mid leg pale as in foreleg but apex of mid tibia always dark brown. Antenna as in Fig. 437, forewing with linea calva interrupted by two lines of setae and closed by a single line on dorsal surface, basal cell with proximal one-third or so naked; genitalia as in Figs 438, 439. Relative measurements (paratype 1): head width 45, minimum frontovertex width 22, scape length 18, forewing length 109, forewing width 48, hindwing length 73, hindwing width 21, aedeagus length 21, mid tibia length 52. Relative measurements (paratype 2): scape length 35·5, maximum scape width 14, POL 17, OOL 8. (Paratype 1 on slide; paratype 2 dry-mounted on card.)

DISTRIBUTION. Cook Is.

BIOLOGY. Unknown.

MATERIAL EXAMINED

Holotype ♀, Cook Is.: Raratonga, Totokuitu, xi.1978 (*E. W. Valentine*) (DSIR).

Paratypes. Cook Is.: 9 ♀, 13 ♂, same data as holotype (DSIR, BMNH, USNM, PPRI, ZI).

COMMENTS. A second species from the Society Is. (BPBM) differs from *nesus* in the arrangement of the scrobes and setae on the interantennal prominence, relative proportions of antennal segments, pattern of infuscation of forewing and venation.

TRECHNITES Thomson

(Key couplet: 72. Fig. 31)

Trechnites Thomson, 1876: 118. Type-species: *Trechnites fuscitarsis* Thomson, by monotypy.

Psylledontus Crawford, 1910: 88. Type-species: *Psylledontus insidiosus* Crawford, by original designation.

Metallonella Girault, 1915a: 77. Type-species: *Metallonella australiensis* Girault, by original designation.

DISTRIBUTION AND SPECIES. Sixteen species, Holarctic, Afrotropical, Oriental, Australasian; five species from review area: *aligarhensis* Hayat, Alam & Agarwal (1975: 90) (India), *australiensis* (Girault, 1915a: 77) (Australia), *manaliensis* Hayat, Alam & Agarwal (1975: 88) (India), *secundus* (Girault, 1915e: 281) (Sri Lanka) and *viridiscutellum* (Girault, 1915a: 132) (**comb. n.** from *Encyrtomyia*), also material from Nepal, Vietnam, Hong Kong, Borneo, New Caledonia and Solomon Is. (BMNH, BPBM).

REFERENCES. Hayat *et al.* (1975: 87–92); Prinsloo (1981: 236).

BIOLOGY. Parasites of nymphs of Psyllidae (Homoptera).

COMMENTS. Placed in the tribe Trechnitini, subtribe Trechnitina (Encyrtinae). It is very close to *Coccidaphycus* from which it can be separated by the characters given in the key.

TRICHOMASTHUS Thomson

(Key couplets: 237, 341, 438, 469. Figs 138, 153, 220)

Trichomasthus Thomson, 1876: 142. Type-species: *Encyrtus cyaneus* Dalman, by subsequent designation of Gahan & Fagan (1923: 148).

Coccidoxenus Crawford, 1913: 248. Type-species: *Coccidoxenus portoricensis* Crawford, by original designation.

DISTRIBUTION AND SPECIES. About 50 species, cosmopolitan; only one species from review area: *mexicanus* (Girault, 1917c: 21) (Hawaiian Is.), also several undetermined species from India, S. China, Hong Kong, Borneo and Australia (BMNH, BPBM, ANIC).

BIOLOGY. Parasites of Coccidae, Diaspididae, Eriococcidae and Pseudococcidae (Homoptera).

COMMENTS. Both *Tetracnemella* and *Stenoteropsis* have been incorrectly synonymised with *Trichomasthus*. *Tetracnemella* is here treated as a synonym of *Ooencyrtus* and *Stenoteropsis* as a valid genus near *Helegonatopus*.

The genus is placed in the Microteriyini, subtribe Microteriyina (Encyrtinae). However, it must be very much closer to *Ooencyrtus* (subtribe Ooencyrtina) than this infers since the two genera occasionally can be difficult to separate.

TRJAPITZINELLUS Viggiani

(Key couplets: 326, 508)

Trjapitzinellus Viggiani, 1967: 166. Type-species: *Trjapitzinellus semidaliphagus* Viggiani, by original designation.

DISTRIBUTION AND SPECIES. Six species, Holarctic, Oriental; possibly two undetermined species from India (BMNH, HC).

REFERENCE. Key to Palaearctic species: Myartseva (1980).

BIOLOGY. Parasites of immature stages of Coniopterygidae (Neuroptera).

COMMENTS. Placed in the Bothriothoracini, subtribe Coenocercina (Encyrtinae).

TROPIDOPHRYNE Compere

(Key couplet: 154)

Tropidophryne Compere, 1931: 269. Type-species: *Tropidophryne africana* Compere, by monotypy.

DISTRIBUTION AND SPECIES. Five species, Afrotropical; one undescribed species from New Britain (BPBM).

REFERENCES. Review: Prinsloo & Anneck (1978b: 312–315); Kerrich (1978: 145–150).

BIOLOGY. Parasites of Pseudococcidae (Homoptera).

COMMENTS. We have not seen the female specimen recorded by Baker (1978: 56, Fig. 3), under the name *Zaplatycerus* sp., but from his figure it is almost certainly a species of *Tropidophryne*. The host given by Baker is also probably incorrect (*Doleschalla* sp.; Diptera, Tachinidae).

The genus belongs in the tribe Chrysoplatycerini, subtribe Chrysoplatycerina (Tetracneminae). A key to related genera is given by Kerrich (1978: 113–114).

TYNDARICHUS Howard

(Key couplets: 184, 415. Fig. 107)

Tyndarichus Howard, 1910: 5. Type-species: *Tyndarichus navae* Howard, by original designation.

DISTRIBUTION AND SPECIES. Seven species, Nearctic, Palaearctic, Afrotropical, Oriental,

Australasian; two species from review area: *melanicis* (Dalman, 1820: 345) (India) and *particornis* (Girault, 1924a: 8) (**comb. n.** from *Epiblatticida*) (Australia), also undetermined material from India, Sri Lanka, Nepal, Hong Kong, Java, Sulawesi, New Britain and Australia (BMNH, BPBM).

BIOLOGY. Hyperparasites of larvae of Lepidoptera through other Encyrtidae (Hymenoptera).

COMMENTS. Placed in the tribe Cheiloneurini, subtribe Epiencyrtina (Encyrtinae) by Trjapitzin & Gordh (1978b). It is very close to *Parechthrodryinus*, from which it can be very difficult to separate if the biology is not known (see characters given in key). This subtribe may be out of place in the Cheiloneurini and it is possible that its included genera are more closely related to those placed in the subtribe Syrphophagina (tribe Microteriyini) since there is some similarity in forewing venation and general morphology, particularly the structure of the thorax.

TYNDARICOPSIS Gordh & Trjapitzin

(Key couplets: 184, 416. Figs 108, 109)

Tyndaricopsis Gordh & Trjapitzin, 1981: 48. Type-species: *Tyndarichus clavatus* Eady, by original designation.

DISTRIBUTION AND SPECIES. One species, New Guinea only: *clavatus* (Eady, 1960a: 669).

BIOLOGY. Hyperparasites of larvae of Pyralidae (Lepidoptera) via other Encyrtidae (Hymenoptera).

COMMENTS. Closely related to *Tyndarichus* which has been placed in the Cheiloneurini, subtribe Epiencyrtina (Encyrtinae) by Trjapitzin & Gordh (1978b) (see comments under *Tyndarichus*). It can be separated from *Tyndarichus* and *Parechthrodryinus* by the characters given in the key.

WHITTIERIA Girault

Whittieria Girault, 1938: 82. Type-species: *Whittieria pilosigena* Girault, by original designation.

DISTRIBUTION AND SPECIES. One species, Australia only: *pilosigena* Girault (1938: 82).

BIOLOGY. Unknown.

COMMENTS. The genus must be related to *Tachardiaephagus*, *Bennettisca* Noyes, *Aloencyrtus* Prinsloo and *Allencyrtus* Annecke & Mynhardt (Microteriyini, subtribe Microteriyina). Girault mentions that the scrobes are 'deep gouges' (a typical character of this group). Also the dense setation of the forewing, venation and structure of the mandible indicate a relationship with the genera of this group. The true systematic position of the genus will not be known until fresh material, including females, is studied.

XENANUSIA Girault

(Key couplets: 75, 107)

Xenanusia Girault, 1917g: 137. Type-species: *Xenanusia pulchripennis* Girault, by original designation.

DISTRIBUTION AND SPECIES. Two species, Australia only: *flava* (Girault, 1915a: 153) (**comb. n.** from *Anusia*) and *pulchripennis* Girault (1917g: 138).

BIOLOGY. Unknown.

COMMENTS. *Xenanusia flava* may be out of place here and may require a new genus to accommodate it. However, we feel that it is correctly placed within the group of genera to which *Xenanusia* belongs.

The type-species of *Xenanusia* is remarkable in that superficially it closely resembles species of *Cerapterocerus* or *Cerapteroceroides*. However, it belongs to the same group of genera as *Cryptanusia*, *Cyrtocoryphes* and *Parectromoidella* (see comments under *Cryptanusia*).

XENOENCYRTUS Riek

(Key couplets: 91, 249. Figs 44, 45)

Xenoencyrtus Riek, 1962a: 151. Type-species: *Xenoencyrtus niger* Riek, by original designation.

DISTRIBUTION AND SPECIES. Four species, Australia only: *hemipterus* (Girault, 1915a: 172), *hemipterus pentlandensis* (Girault, 1915a: 173), *hemipterus stigmatiferus* (Girault, 1923c: 147), *megymeni* (Dodd, 1917: 354), *megymeni brachypterus* (Dodd, 1917: 355), *niger* Riek (1962a: 152) and *rubricatus* Riek (1962a: 154), also much undetermined material from Australia (BMNH, ANIC, QM).

REFERENCE. Revision: Riek (1962a).

BIOLOGY. Parasites of eggs of Pentatomidae (Heteroptera).

COMMENTS. The types of *hemipterus pentlandensis* and *hemipterus stigmatiferus* cannot be located. (Girault actually described *Ericydnus stigmatifera hemiptera* (1923c: 147), but we feel that somehow the specific and subspecific names must have become juxtaposed either by a *lapsus* on Girault's part or by a type-setting error.)

It is probable that all the species included by Riek in this genus are all forms of the same species.

The genus is close to *Ooencyrtus*, *Ovaloencyrtus* and *Paratetralophidea* (Microteriyini, subtribe Ooencyrtina) and can be separated from these genera by the characters given in the key.

XENOSTRYXIS Girault

(Key couplets: 296, 348. Fig. 440)

Xenostryxis Girault, 1920a: 41. Type-species: *Xenostryxis margiscutellum* Girault, by monotypy.

DISTRIBUTION AND SPECIES. One species, known only from Australia: *margiscutellum* Girault (1920a: 41), possibly the same species distributed to India and southern Africa (BMNH, PPRI).

BIOLOGY. Unknown.

COMMENTS. *Xenostryxis* is probably related to either *Neococcidencyrtus* (tribe ?Habrolepidini) or *Thomsonisca* (tribe Thomsoniscini) (Encyrtinae).

YASUMATSUIOLA Trjapitzin

(Key couplet: 158. Figs 82, 441)

Yasumatsuiola Trjapitzin, 1977: 153. Type-species: *Yasumatsuiola orientalis* Trjapitzin, by original designation.

DISTRIBUTION AND SPECIES. One described species, Thailand: *orientalis* Trjapitzin (1977: 155), also further undetermined material, which may include at least one undescribed species, from India, Philippines and Australia (BMNH, BPBM).

BIOLOGY. Unknown.

COMMENTS. Placed in the tribe Dinocarsini (Tetracneminae).

ZAMENHOFELLA Girault

(Key couplet: 332)

Zamenhofella Girault, 1941:132. Type-species: *Zamenhofella voltai* Girault, by monotypy.DISTRIBUTION AND SPECIES. One species, Australia only: *voltai* Girault (1941: 133).

BIOLOGY. Unknown.

COMMENTS. We are unable to place this genus according to Trjapitzin's (1973*b*) classification of the Encyrtinae. It bears some resemblance to *Austroencyrtus* (which may be related to the Bothriothoracini, see comments under *Austroencyrtus*).

ZAOMMA Ashmead

(Key couplet: 101. Fig. 49)

Zaomma Ashmead, 1900*b*: 401. Type-species: *Encyrtus argentipes* Howard, by original designation.

Apterencyrtus Ashmead, 1905*a*: 5. Type-species: *Apterencyrtus pulchricornis* Ashmead, by original designation.

Metallonoidea Girault, 1915*c*: 169. Type-species: *Metallonoidea brittanica* Girault, by monotypy.

Chiloneurinus Mercet, 1921: 646. Type-species: *Chiloneurus microphagus* Mayr, by original designation.

Richardsius Alam, 1957: 439. Type-species: *Apterencyrtus thomsoniscae* Alam, by original designation. [As subgenus of *Apterencyrtus*.]

Metapterencyrtus Tachikawa, 1963: 213. Type-species: *Metapterencyrtus eriococci* Tachikawa, by original designation.

DISTRIBUTION AND SPECIES. Thirteen species, cosmopolitan; one species from review area: *lambinus* (Walker, 1838*a*: 422) (India, Java, Philippines, New Zealand, Hawaiian Is.), also undetermined material from Taiwan (UCR).

REFERENCES. Key to species: Gordh & Trjapitzin (1979*a*); revision of Afrotropical species: Prinsloo (1979).

BIOLOGY. Hyperparasites of Diaspididae (Homoptera) through other Encyrtidae (Hymenoptera).

COMMENTS. Ashmead (1905*a*: 5) described *Apterencyrtus pulchricornis* from the Philippines. This species has since been synonymised with *microphagus* Mayr (= *lambinus*) by Gahan (1951: 171), a synonymy which has been followed here. However, in the light of recent work by Gordh & Trjapitzin (1979*a*) and Prinsloo (1979), a more detailed study may show that the two species are distinct.

ZAOMMOENCYRTUS Girault

(Key couplet: 214, 509. Figs 250, 251, 442–444)

Zaommoencyrtus Girault, 1916*a*: 46. Type-species: *Zaommoencyrtus submicans* Girault, by monotypy.

Bethylomimus Trjapitzin, 1962*a*: 430. Type-species: *Bethylomimus liaoi* Trjapitzin, by original designation.

DISTRIBUTION AND SPECIES. Five species, Holarctic, and also several undescribed species from Papua New Guinea, Caroline Is., Solomon Is. and Fiji (BPBM, USNM).

REFERENCE. Review of Palaearctic species: Khlopunov (1981).

BIOLOGY. Parasites of larvae of Tenebrionidae and eggs and larvae of Cerambycidae (Coleoptera).

COMMENTS. We have compared specimens of the Australasian species with authentic specimens of *submicans*; we regard them as congeneric even though they are relatively larger and have a relatively longer pronotum, although the latter is variable even within the Australasian material.

The genus is placed in the Bothriothoracini, subtribe Coenocercina (Encyrtinae) and is very close to *Cerchysiella* from which it can be separated by the characters given in the key.

ZARHOPALOIDES Girault

(Key couplets: 179, 376, 412, 504)

Zarhopaloides Girault, 1915*a*: 99. Type-species: *Zarhopaloides axillaris* Girault, by original designation.

DISTRIBUTION AND SPECIES. Four species, all Australian: *auricaput* (Girault, 1923c: 145) (comb. n. from *Ooencyrtus*), *axillaris* Girault (1915a: 99), *cinctithorax* (Girault, 1939a: 20) (comb. n. from *Anagyropsis*) and *speciosus* Girault (1932a: 5), also further undetermined material from Australia (BMNH).

BIOLOGY. One species (*cinctithorax*) has been reared from a species of *Cleptes* (Chrysididae).

COMMENTS. It is possible that a new genus is required for *cinctithorax* since it may be misplaced in this genus. The marginal vein of the forewing is clearly much longer than broad, this being punctiform in the three other species. It may be more closely related to *Coelopencyrtus*.

Mesanusia speciosa Girault (1932a: 1) may also belong in this genus (see p. 353).

Zarhopaloides appears to be closely related to *Metaphycus* (Aphycini, Paraphycina) and differs from it by the characters given in the key.

ZEALANDENCYRTUS Tachikawa & Valentine

(Key couplet: 58)

Zealandencyrtus Tachikawa & Valentine, 1971: 27. Type-species: *Zealandencyrtus yasumatsui* Tachikawa & Valentine, by original designation.

DISTRIBUTION AND SPECIES. One species, New Zealand only: *yasumatsui* Tachikawa & Valentine (1971: 28).

BIOLOGY. Parasites of Pseudococcidae (Homoptera).

COMMENTS. Placed in the tribe Tetracneminae, subtribe Arhopoideina (Tetracneminae). It is close to *Tetracnemoidea* and can be separated from it by the characters given in the key.

ZOOENCYRTUS Girault

(Key couplets: 141, 305)

Zooencyrtus Girault, 1915a: 107. Type-species: *Zooencyrtus acutiventris* Girault, by original designation.

DISTRIBUTION AND SPECIES. Two species, Australia only: *acutiventris* Girault (1915a: 107) and *partipilum* Girault (1923a: 49), also one undetermined specimen from Papua New Guinea (BPBM).

BIOLOGY. Unknown.

COMMENTS. We have also examined a group of four species from Papua New Guinea and the Solomon Is. (BPBM) which may belong to this genus, but the antennal toruli are situated much closer to the mouth margin, being separated by much less than their own lengths.

We are unable to satisfactorily place the genus. It appears to be related to *Achalcerinys* (see comments under *Achalcerinys*) and *Mahencyrtus* but also has some similarities with *Helegonatorpus* and related genera (tribe Chalcerinyini). It may also be close to *Mayridia* (see comments under *Mayridia*) but differs from this genus in that the postmarginal vein of the forewing is not shorter than the stigmal and the propodeum is relatively longer.

ZOZOROS gen. n.

(Key couplet: 124. Figs 61, 65, 445-450)

Type-species: *Zozoros sinemarginis* sp. n. Gender: masculine.

♀. *Head*. In frontal view a little broader than long, in profile slightly more than one and one-half times as long as broad and more or less evenly and gradually rounded anteriorly but with protuberances between antennal toruli and eye and interantennal prominence clearly visible. Eye naked, posterior margin more or less straight, about one-quarter to one-third longer than broad and overreaching occipital margin which is sharp or more or less rounded. Malar space about one-half as long as an eye, sulcus present. Frontovortex about one-quarter to two-fifths head width; ocelli forming an angle of about 90°, the posterior ones nearly touching eye margins and separated from occipital margin by about to more than their own diameters.

Antennal scrobes reaching about two-fifths from toruli to anterior ocellus, meeting dorsally, broadly semicircular and delimited dorsally by a moderately sharp carina and laterally, between eyes and antennal toruli, by a slight protuberance, interantennal prominence also clearly protuberant between toruli; antennal torulus separated from mouth margin and from other torulus by about its own length, its upper margin about level with lowest eye margins; clypeus very shallowly and broadly excised, with about six or seven very long downwardly directed bristles. Antennal scape clearly longer than maximum width of frontovertex, broadened and flattened, about twice as long as broad; pedicel conical, about one-quarter length of scape and clearly longer than any of the funicle segments which are cylindrical and slightly broadening distally and all transverse except first; clava about as long as or longer than funicle, strongly obliquely truncate apically, three-segmented, both sutures strongly converging towards base of clava; longitudinal sensillae on all flagellar segments but the first; longest setae about as long as diameter of first funicle segment. Frontovertex with piliferous punctures shallow or well marked and deep, giving the appearance of the surface of a thimble, punctures on lower parts of face shallower and more irregular, areas between punctures smooth or with irregular, shallow sculpture; protuberances between toruli and eyes and between toruli each with irregular, shallow, raised, reticulate sculpture of fairly small mesh, this becoming of larger mesh, more irregular and coriaceous-reticulate on lower parts of face; setae on frontovertex fairly dense and conspicuous. Mandible with three, sharp, apical teeth; maxillary palpus four-segmented, labial palpus three-segmented.

Thorax. In side view robust with both mesoscutum and scutellum very slightly convex, almost flat; metapleurum together with propodeum broadly separated from hind coxa by the enlarged mesopleurum which is more or less touching basal segment of gaster. In dorsal view pronotum shallowly concave; mesoscutum with notaular lines absent, about twice as broad as long, its posterior margin convex and projecting above axillae, thus appearing to separate them; axillae meeting; scutellum convex, about as long as broad, with apex almost pointed; propodeum medially nearly one-third length of scutellum. Pronotum and mesoscutum with shallow, raised, squamiform-reticulate sculpture, sculpture of axillae similar but of finer mesh, sculpture of scutellum similar but more longitudinally elongate; piliferous punctures conspicuous, a little shallower and smaller than those on frontovertex; mesopleurum with very irregular, shallow, raised, rugose sculpture; propodeum with strong, raised, irregular sculpture which is deepest medially. Forewing more or less evenly infusate, about two and one-half times as long as broad; linea calva not interrupted or closed; filum spinosum present; basal cell with setae evenly distributed and longer than those distal to linea calva; submarginal vein without an apical hyaline break, parastigma hardly swollen, not much wider than proximal part of vein; costal cell about 13–14 times as long as broad, with one or two lines of setae dorsally along its entire length; marginal vein punctiform or absent; stigmal vein curved, clearly much longer than the short postmarginal; a hyaline and naked line from apex of postmarginal to apex of stigmal veins. Hindwing hyaline, about two-thirds length of forewing, about three and one-half times as long as broad, with marginal fringe about one-sixth as long as maximum wing width. Mid tibial spur about as long as basal mid tarsal segment.

Gaster. About as long as thorax; cercal plates in basal one-third; hypopygium more or less reaching apex of gaster; last tergite a little shorter than to about as long as mid tibia, with apex rounded; paratergites absent; ovipositor very slightly exerted and, in type-species, a little longer than mid tibia; gonostyli free, about one-fifth as long as ovipositor.

♂. Unknown.

COMMENTS. *Zozoros* appears to be closely related to both *Leurocerus* and *Paksimmondsius* (Microteryini, Ooencyrtina, see comments under *Leurocerus*). It can be separated from both of these in having the hypopygium extending to the apex of the gaster and the relatively long propodeum (less than one-sixth length of scutellum in these two genera). From *Leurocerus* it can also be distinguished by the cylindrical flagellar segments (flattened in *Leurocerus*), and from *Paksimmondsius* by the wing shape, naked eyes and very long, obliquely truncate clava since *Paksimmondsius* has a very broad forewing (less than twice as long as broad), hairy eyes and relatively short, apically rounded clava.

Zozoros sinemarginis sp. n.

(Figs 61, 65, 445–450)

♀. Length: 2.16 mm.

Colour. Body generally brown excepting following areas: head on frontovertex more or less metallic green with blue and purple reflections, strongly purple on dorsal part of protuberance between torulus and

eye, lower parts of face orange-brown; scape orange-brown, broadly dark brown along ventral margin and a little more narrowly so along dorsal margin, pedicel dark brown, flagellum blackish brown; posterior part of pronotum weakly and mesoscutum more strongly tinged metallic blue, purple and blue-green, axillae very weakly metallic, scutellum strongly metallic greenish blue with some purple, particularly in piliferous punctures; forewing weakly suffused brown, more or less hyaline in proximal half of basal cell and whole of costal cell, a hyaline streak connecting apex of postmarginal to stigmal vein, a small area opposite and apex more or less hyaline; gaster more or less dark reddish brown with brassy and some purple reflections.

Head. Frontovortex with deep conspicuous piliferous punctures, these touching or almost touching one another, particularly near ocelli (Fig. 445), areas between punctures quite smooth, lower parts of face with irregular, raised, reticulate sculpture, this of smaller mesh on protuberances between antennal toruli and eyes; occipital margin more or less rounded. Relative measurements (holotype): head length 99, head width (facial view) 111, head width (side view) 63, minimum frontovortex width 35, diameter of posterior ocellus 7, length of antennal torulus 17, distance of torulus from mouth margin 15, malar space 30, eye length 69, eye width 52, POL 22, OOL 1, scape length 71, scape width 35, other proportions of antenna as in Fig. 65.

Thorax. Sculpture of mesoscutum, scutellum and propodeum as in Figs 447, 448, 450. Relative measurements (holotype): forewing length 281, width 114; hindwing length 193, width 55; base of forewing as in Fig. 61.

Gaster. Relative length (paratype): ovipositor 73, last tergite 65, [mid tibia 69]; genitalia as in Fig. 446, hypopygium as in Fig. 449.

♂. Unknown.

DISTRIBUTION. Hong Kong.

BIOLOGY. Unknown.

MATERIAL EXAMINED

Holotype ♀, **Hong Kong**: N.T., Sai Kung Station, 30.i.1965 (*W. J. Voss & Hui Wai Ming*) (BPBM).

Paratype. **Hong Kong**: 1 ♀, same data as holotype, 30.xii.1964 (BMNH).

COMMENTS. We have examined three specimens from the Philippines, Brunei and New Britain which appear to belong to two further species. These differ from *sinemarginis* in having a sharp occipital margin, forewing with a punctiform marginal vein and head and dorsum of thorax with shallower piliferous punctures. They also differ from each other and *sinemarginis* in the relative width of an eye, frontovortex, size of ocelli and toruli, antennal proportions and relative length of last tergite of the gaster.

Incertae sedis

Ageniaspis indicus Narayanan (1961: 23) (India). We have not seen the types of this species and are unable to place it satisfactorily from the very poor description. It cannot belong in *Ageniaspis*, but it may possibly belong to the genus *Teleterebratus*.

Anagyrus saintpierrei Girault (1913e: 112) (Australia). The species superficially resembles some species of *Psyllaephagus*, but the mandible has only two sharp teeth. Girault (1915a: 147) placed the species in *Fulgoridicida* but this must be incorrect. It is possibly an aberrant species of *Coelopencyrtus*.

Anagyrus semifulvus Girault (1915a: 136) (Australia). We are unable to place the species, although it may belong to *Rhopalencyrtoidea*.

Cerchysius australiensis Ashmead (1900a: 342) (Australia). We have examined the holotype of this species (USNM). It is close to *Psyllaephagus*, but we are unable to place it in this genus because of the following combination of characters: (1) hypopygium more or less reaching the apex of the gaster, (2) first funicle segment clearly longer than pedicel and (3) forewing with marginal vein about three to four times as long as broad (see couplet 232).

Encyrtus adustipennis Motschulsky (1863: 55) (Sri Lanka). We have not seen the holotype of this species; according to Trjapitzin (Bouček, pers. comm.) it is badly damaged and unplaceable to genus.

Encyrtus solidus Howard (in Howard & Ashmead, 1896: 638) (Sri Lanka). The holotype male (USNM) has been examined. We are unable to place the species. The antenna is very characteristic, having a seven-segmented flagellum, but with each segment having the appearance of those found in *Coccophagus*. The longitudinal sensillae are very prominent (as in some male *Cerchysiella*) and the funicle segments gradually shorten towards the apex of the antenna so that the sixth is less than half as long as the first.

Encyrtus zebinia Walker (1839: 36) (Australia). No types located. We are unable to place the species from Walker's brief description.

Mesanusia speciosa Girault (1932a: 1). We cannot place this species. It may be related to *Metaphycus*, *Zarhopaloides* or perhaps *Aphycopsis* (see key couplet 413).

Systematic relationships of Indo-Pacific encyrtid genera

The following summary of the possible systematic relationships between the Indo-Pacific genera is based on the system of classification as proposed by Trjapitzin (1973a; 1973b). It must be stated here that we do not fully agree with the tribal and subtribal classification proposed by him, but we do agree with the basic division of the Encyrtidae into two subfamilies.

ENCYRTIDAE

Encyrtinae

Microteriyini

Aphycomorpha, *Aphycopsis*,
? *Australanusia*, ? *Ectopiognatha*,
? *Exoristobia*, *Gahaniella*, ? *Mozartella*,
? *Parablatticida*, ? *Phauloencyrtus*

Microteriyina

Bothriophryne, *Doddanusia*, *Erencyrtus*,
? *Hesperencyrtus*, *Microtelys*,
Neastymachus, *Paraphaenodiscus*,
Philosindia, *Tachardiaephagus*,
Trichomasthus, *Whittiera*

Pseudencyrtina

? *Cerchysius*, ? *Papuna*, *Paraenasomyia*,
Saprencyrtus

Syrphophagina

? *Austroencyrtoidea*, ? *Bachiana*,
Coccidoctonus, ? *Conchynilla*,
Diaphorencyrtus, *Epiblatticida*,
? *Nezarhopalus*, *Psyllaphycus*,
Rhopalencyrtoidea, *Syrphophagus*,
Tassonia, *Teleterebratus*

Oobiina

Avetianella, *Szelenyiola*

Ooencyrtina

Agarwalencyrtus, *Fulgoridicida*, *Hengata*,
Isodromoides, ? *Leefmansia*, ? *Leurocerus*,
Mesanusia, *Ooencyrtus*, *Ovaloencyrtus*,
Paratetralophidea, *Xenoencyrtus*

Amirini

Amira

Comperiini

Comperia

Cheiloneurini

Achalcerinys, *Austromira*, *Baeoanusia*,
Cheiloneurella, *Cheiloneuromyia*,

Cheiloneurus, *Diversinervus*,
Echthrobaccella, *Echthrogonatopus*,
Ectroma, ? *Exoristobia*, ? *Hypergonatopus*,
Mahencyrtus, ? *Meniscocephalus*,
Mesocalocerinus, *Neabrolepoideus*,
Neblatticida, *Parechthrodryinus*,
? *Pasulinia*, *Procheiloneurus*,
Prochiloneurus, ? *Protynдарichoides*,
Tineophoctonus, *Tyndaricopsis*,
Tyndarichus, *Zaomma*, ? *Zooencyrtus*

Cerapterocerini

Anicetus, *Cerapteroceroides*,
Cerapterocerus, *Eusemion*,
Lakshaphagus, *Paraceraprocercus*

Thomsoniscini

Thomsonisca, ? *Xenostryxis*

Habrolepidini

? *Pasulinia*, ? *Xenostryxis*

Habrolepidina

Adelencyrtoides, *Adelencyrtus*,
Caenohomalopoda, *Coccidencyrtus*,
Epitetracnemus, *Epitetralophidea*,
Habrolepis, *Homalopoda*, *Plagiomerus*,
Ruskiniana

Comperiellina

Comperiella, ? *Neocladella*, *Paraschedius*,
Spaniopterus

Trechnitini

Mesorhopella, *Pararhopella*

Trechnitina

Coccidaphycus, *Trechnites*

Metaprimonitina

Aenasiella, ? *Cerchysius*, *Neanagyus*,
? *Parachalcerinys*, *Psyllaephagus*

Aphycini

Australia, ? *Prionomitoides*

Aphycina
Acerophagus, *Aphycus*, *Epistenoterys*,
Indaphycus, *Pseudaphycus*,
Pseudectroma, *Pseudococcobius*

Paraphycina
Aenasioidea, *Aenasomyiella*,
Australaphycus, *Beethovena*, *Metaphycus*,
Nassauia, *Paraphycus*, *Zarhopaloides*

Blastothrichina
Blastothrix

Homalotylini
 Homalotylinea
Copidosomyia, *Homalotylus*, *Isodromus*

Bothriothoracini
 ?*Aseirba*, ?*Austroencyrtus*, *Borrowella*,
 ?*Brachyplatycerus*, ?*Encyrtoidea*,
 ?*Ethoris*, ?*Hemileucocerus*, ?*Hexencyrtus*,
 ?*Leurocerus*, ?*Paksimmondsius*,
 ?*Parencyrtomyia*, ?*Pentelicus*

Bothriothoracina
Bothriothorax, *Heterococcidoxenus*

Coenocercina
Cerchysiella, *Gentakola*, ?*Parastenoterys*,
Pentacladocerus, ?*Rhytidothorax*,
 ?*Trjapitzinellus*, *Zaommoencyrtus*

Aminellina
Amicencyrtus, *Cowperia*

Proleurocerini
Proleuroceroides, *Proleurocerus*

Rhinoencyrtini
Paratetracnemoidea

Copidosomatini
 Ageniaspidina
Ageniaspis, ?*Coagerus*, ?*Ethoris*,
Holcothorax

Copidosomatina
Copidosoma, *Copidosomopsis*,
Paralitomastix, *Raffaellia*

Coelopencyrtina
Coelopencyrtus, ?*Nathismusia*

Cercobelini
Cercobelus

Astymachini
Astymachus

Ixodiphagini
Hunterellus

Aethognathini
Olypusa

Prionomasticini
 ?*Meniscocephalus*

Prionomasticina
Eucomomorphella, *Prionomastix*

Encyrtini
Encyrtus, ?*Muluencyrtus*

Neocladini
Carabunia, *Neocladia*, *Paracladella*,
Paraleptomastix

Eugahaniini
Anagyrodes, *Eugahania*

Psyllechthriini
Arrhenophagoidea

Arrhenophagini
Arrhenophagus

Anthemini
Anthemus

Incertae sedis
Haligra, *Lamennasia*, *Mesastymachus*,
Negeniaspidius, *Ovidoencyrtus*

Tetracneminae

Charitopidini
Adekitopus, *Charitopus*, *Clausenia*,
Eotopus, *Manicnemus*, *Neocharitopus*,
Paraclausenia, *Parectromoides*

Miraini
Mira, *Sakencyrtus*

Ericydnini
Ericydnus

Dinocarsiini
 ?*Callipteroma*, ?*Cryptanusia*,
 ?*Cyrtocoryphes*, ?*Epanusia*,
Holanusomyia, ?*Parectromoidella*,
Praleurocerus, ?*Xenania*,
Yasumatsuiola

Anagyriini
 Rhopiina
Asitus, *Hamusencyrtus*, *Neorhopus*,
Platyrhopus, *Rhopus*

Anagyriina (= Leptomastideina *syn. n.*)
Alamella, *Anagyrietta*, *Anagyryus*,
Anomalencyrtus, *Apoleptomastix*,
Bacalusa, *Cremesina*, *Doliphoceras*,
Epidinocarsis, *Gyranusoidea*,
Leptomastidea, *Leptomastix*,
Mashhoodia, *Paranathrix*, *Tongyus*

Anusiina
 ?*Monstranusia*, ?*Schilleriella*

Anomalicorniini
Anomalicornia

Pauridiini
Coccidoxenoides, *Marxella*

Tetracnemini
 Tetracnemina
Tetracnemus, ?*Monstranusia*

Arhopoideina
Anarhopus, *Tetracnemoidea*,
Zealandencyrtus

Aenasiini (= Neodiscodini **syn. n.**)

Aenasius, *Ameniscocephalus*, *Blepyrus*,
Cladiscodes, *Euryrhopalus*,
Metaphaenodiscus, *Neodiscodes*

Acroaspidini

Coelaspidia

Chrysolatycerini

Chrysoplatycerina

Cerapterocerella, *Chrysoplatycerus*,
Neoplatycerus, *Tropidophryne*

Taftiina

Ananusia, *Hambletonia*, *Lutherisca*, *Taftia*

Incertae sedis

Neodusmetia, *Ruanderoma*

Host index

Unless otherwise stated, hosts are usually in the larval or nymphal stage. A comprehensive world coverage of the hosts of the Encyrtidae is given by Tachikawa (1981).

ARACHNIDA

ARANEIDA

Eggs: *Amira*, *Ooencyrtus*, *Proleurocerus*

ACARINA

Ixodidae

Hunterellus

INSECTA

NEUROPTERA

Chrysopidae

Copidosomyia, *Isodromus*

Coniopterygidae

Trjapitzinellus

Hemerobiidae

Isodromus

DICTYOPTERA

BLATTODEA

Eggs: *Comperia*, *Mesanusia*

ORTHOPTERA

Tettigoniidae

Eggs: *Leefmansia*, *Mesanusia*

HETEROPTERA

Eggs: *Ooencyrtus*

Coreidae

Eggs: *Paratetralophidea*

Pentatomidae

Eggs: *Xenoencyrtus*

Reduviidae

Eggs: *Ovidoencyrtus*

HOMOPTERA

Cheiloneurus (hyperparasitic)

AUCHENORRHYNCHA

Echthronatopus (hyperparasitic),

Helegonatopus (hyperparasitic),

Hypergonatopus (hyperparasitic),

Ooencyrtus (hyperparasitic)

Cercopidae

Carabunia

Cicadellidae

Anagyrodes, *Eugahania*, *Meniscocephalus*,

Neocladia

Eurybrachidae

Eggs: *Ectopiognatha*, *Fulgoridicida*,
Proleurocerus

Flatidae

Eggs: *Ectiopiognatha*

Fulgoridae

Isodromoides (hyperparasitic)

Lophopidae

Eggs: *Proleuroceroides*

Membracidae

Prionomastix

STERNORRHYNCHA

Aphididae

Cerapteroceroides (hyperparasitic),
Ooencyrtus, *Syrphophagus* (also
hyperparasitic), *Tassonia*

Psyllidae

?*Aenasomyiella*, *Cerapteroceroides*
(hyperparasitic), *Cercobelus*, *Coccidoctonus*
(hyperparasitic), *Diaphorencyrtus*,
Epiblatticida (hyperparasitic), *Neanagyrs*,
Psyllaephagus (also hyperparasitic),
Psyllaphycus, *Syrphophagus*, *Trechnites*

COCCOIDEA

Nassauia, *Prochiloneurus* Silvestri
(hyperparasitic)

Aclerididae

Astymachus, *Mayridia*, *Neastymachus*

Asterolecaniidae

Habrolepis, *Lakshaphagus*, *Metaphycus*,
Neastymachus

Coccidae

Aenasioidea, *Anicetus*, *Blastothrix*,
Bothriophryne, *Cerapteroceroides*
(hyperparasitic), *Cerapterocer*
(hyperparasitic), *Cheiloneuromyia*,
Coccidaphycus, *Coccidoctonus*
(hyperparasitic), *Diversinervus*, *Encyrtus*,
Eusemion, *Gahaniella* (also hyperparasitic),
Mashhoodiella, *Metaphycus*, *Microterys*,
Paracerapterocer, *Paraphaenodiscus*,
Parechthrodryinus, *Trichomasthus*

Diaspididae

Adelencyrtoides, *Adelencyrtus*, *Anthemus*,
Aphycomorpha, *Arrhenophagoidea*,
Arrhenophagus, *Bachiana*,
Caenohomalopoda, *Cerapteroceroides*
(hyperparasitic), *Coccidencyrtus*,
Comperiella, *Epitetracnemus*, *Habrolepis*,
Homalopoda, *Metaphycus*, *Paraschedius*,
Plagiomerus, *Spaniopterus*, *Teleterebratus*,
Thomsonisca, *Trichomasthus*, *Zaomma*
(hyperparasitic)

Eriococcidae

Aenasiella, *Aphycomorpha*, *Metaphycus*,
Saprenicyrtus, *Teleterebratus*,
Trichomasthus

Kermesidae

Aenasioidea, ?*Blastothrix*, *Microterys*,
Paksimmondsius

Keriidae

Erencyrtus, *Lakshaphagus*, *Metaphycus*,
Parechthrodryinus, *Tachardiaephagus*

Lecanodiaspididae

Microterys

Margarodidae

Eotopus

Pseudococcidae

Acerophagus, *Aenasius*, ?*Agarwalencyrtus*,
Alamella, *Anagyrietta*, *Anagyryus*,
? *Ananusia*, *Anarhopus*, *Anomalicornia*,
Aphycus, *Apoleptomastix*, *Asitus*,
? *Astymachus*, *Blepyrus*, *Callipteroma*,
Ceraptocerella, *Cerapteroceroides*
(hyperparasitic), *Chrysoplatycerus*,
Cladiscodes, *Clausenia*, *Coccidoctonus*
(hyperparasitic), *Coccidoxenoides*,
Coelaspida, *Cryptanusia*, *Doliphoceras*,
Epidinocarsis, *Epistenoterys*, *Ericydnus*,
Euryrhopalus, *Gahaniella* (hyperparasitic),
Gyranusoidea, *Hambletonia*,
Hamusencyrtus, *Leptomastidea*,
Leptomastix, *Mashhoodia*, *Mayridia*,
Metaphaenodiscus, *Neocharitopus*,
Neodiscodes, *Neodusmetia*, *Neoplatycerus*,
Neorhopus, *Paranathrix*, *Platyrhopus*,
Praleurocerus, *Pseudaphycus*,
Pseudectroma, *Pseudococcobius*, *Rhopus*,
Taftia, *Tetracnemoidea*, *Tetracnemus*,
Trichomasthus, *Tropidophryne*,
Zealandencyrtus

LEPIDOPTERA

Eggs: *Ooencyrtus*

Larvae: *Copidosoma*, *Ooencyrtus*
(hyperparasitic), *Tyndarichus*
(hyperparasitic)

Amathusiidae

Eggs: *Leurocerus*

Epiptropidae

Isodromoides

Gelechiidae

Paralitomastix

Gracillariidae

Holcothorax

Lycaenidae

Pupae: *Hesperencyrtus*

Lyoniidae

Parablastothrix

Nepticulidae

Holcothorax, *Parablastothrix*

Pyrilidae

Copidosomopsis, *Paralitomastix*, *Tyndaricopsis*
(hyperparasitic)

Satyridae

Eggs: *Leurocerus*

Tineidae

Tineophoctonus

Tortricidae

Copidosomopsis

Yponomeutidae

Ageniaspis

COLEOPTERA

Anobiidae

Tineophoctonus

Buprestidae

Eggs: *Szelenyiola*

Cerambycidae

Austroencyrtus, *Tineophoctonus*,
Zaommoencyrtus; Eggs: ?*Aenasiella*,
Avetianella, *Zaommoencyrtus*

Chrysomelidae

Eggs: see *Baeoanusia*

Coccinellidae

Anagyryus, *Cowperia*, *Homalotylus*,
Prochiloneurus Silvestri (hyperparasitic)

Erotylidae

Cerchysiella

Lathridiidae

?*Lamennaisia*

Nitidulidae

Cerchysiella

Scolytidae

Heterococcidoxenus, ?*Protyndarichoides*;
Eggs: *Avetianella*, *Szelenyiola*

Silvanidae

Cerchysiella

Tenebrionidae

Zaommoencyrtus

DIPTERA

Calliphoridae

Puparia: *Tachinaephagus*

Cecidomyiidae

Mayridia, *Paraenasomyia*

Chamaemyiidae

Cerchysius

Drosophilidae

Cheiloneurus

Muscidae
 Puparia: *Tachinaephagus*
 Phoridae
 Puparia: *Exoristobia*
 Pipunculidae
 ?*Agarwalencyrtus*
 Sarcophagidae
 Puparia: *Tachinaephagus*
 Syrphidae
 Puparia: *Bothriothorax*, *Exoristobia*,
Ooencyrtus, *Syrphophagus*
 Tachinidae
 Puparia: *Exoristobia*
 Tephritidae
 Puparia: *Tachinaephagus*
 Trypetidae
Cerchysiella
HYMENOPTERA
 Aphelinidae
Cerapteroceroides, *Cheiloneurus*,
Syrphophagus
 Apidae
Coelopencyrtus
 Braconidae
Ooencyrtus
 Cynipidae
Tineophoctonus
 Chrysididae
Zarhopaloides
 Dryinidae
Cheiloneurus, *Echthrogonatopus*,
Helegonatopus, *Hypergonatopus*,
Ooencyrtus
 Encyrtidae
Cerapteroceroides, *Cerapterocerus*,
Cheiloneurus, *Coccidoctonus*, *Epiblatticida*,
Gahaniella, *Prochiloneurus* Silvestri,
Psyllaephagus, *Tyndarichus*, *Tyndaricopsis*,
Zaomma
 Formicidae
 ?*Ananusia*
 Hylaeidae
Coelopencyrtus
 Pteromalidae
Cheiloneurus, *Coccidoctonus*
 Xylocopidae
Coelopencyrtus
PLANT GALLS
Mozartella

Proposed new synonymies

(Junior synonyms on right)

Tribal

Aenasiini Kerrich **stat. n.** = *Neodiscodini*
 Trjapitzin **syn. n.**

Subtribal

Anagyryna Hoffer = *Leptomastideina* Trjapitzin
syn. n.

Generic

Achalcerinys Girault = *Echthrobaconomyia* Girault
syn. n.
Aenasomyiella Girault = *Zaomommoencyrtus*
 Girault **syn. n.**
Ageniaspis Dahlbom = *Leuroceroides* Girault
syn. n., = *Microrhopus* Girault **syn. n.**
Ananusia Girault = *Myrmencyrtus* Gordh &
 Trjapitzin **syn. n.**
Austrochorea Girault = *Chinchilla* Girault
syn. n., = *Chinchillisca* Ghesquière **syn. n.**
Callipteroma Motschulsky = *Vosleria*
 Timberlake **syn. n.**
Carabunia Waterston = *Elijahia* Girault, **syn. n.**,
 = *Schillerana* Girault **syn. n.**
Cerapterocera Girault = *Austrotropidia* Kerrich
syn. n.
Cerchysiella Girault = *Araticus* Ghesquière
syn. n., = *Aratus* Howard **syn. n.**, =
Erycydnella Girault **syn. n.**, = *Mirrencyrtus*
 Girault **syn. n.**, = *Prolitomastix* Hoffer **syn. n.**,
 = *Zeteticontus* Silvestri **syn. n.**
Charitopus Förster = *Eupelmomorpha* Girault
syn. n.
Cheiloneurus Westwood = *Chrysopophagoides*
 Girault **syn. n.**, = *Epicheiloneurus* Girault **syn.**
n., = *Eusemionella* Girault **syn. n.**, =
Eusemionopsis Girault **syn. n.**, =
Paracheiloneurus Girault **syn. n.**
Coccidencyrtus Ashmead = *Encyrtomyia* Girault
syn. n., = *Neoadelencyrtus* Hayat, Alam &
 Agarwal **syn. n.**, = *Omphalencyrtus* Girault
syn. n.
Coccidoctonus Crawford = *Cerchysiopsis* Girault
syn. n.
Coccidoxenoides Girault = *Pauridia* Timberlake
syn. n.
Coelopencyrtus Timberlake = *Epaenasomyia*
 Girault **syn. n.**, = *Giraultella* Gahan & Fagan
syn. n., = *Lymanera* Szelenyi **syn. n.**
Copidosoma Ratzeburg = *Angeliconana* Girault
syn. n., *Mesencyrtus* Timberlake **syn. n.**,
Mesocopidosomyia Girault **syn. n.**,
Paracaenocercus Girault **syn. n.**, =
Parasteropaes Girault **syn. n.**, = *Pentacnemus*
 Howard **syn. n.**, = *Pseudencyrtella* Girault
syn. n., = *Zaomencyrtus* Girault **syn. n.**
Copidosopsis Girault = *Pentalitomastix* Eady
syn. n., = *Pseudolitomastix* Eady **syn. n.**
Copidosomyia Girault = *Acridencyrtus* Subba
 Rao **syn. n.**, = *Neochrysopophilus* Tachikawa
syn. n.
Cowperia Girault = *Aminellus* Masi **syn. n.**
Epiblatticida Girault = *Blatticidella* Girault
syn. n., = *Magellanana* Girault **syn. n.**, =

- Microencyrtus* Girault **syn. n.**, =
Neasteropaeus Girault **syn. n.**
Epidinocarsis Girault = *Apoanagyrus* Compere
syn. n.
Epistenoterys Girault = *Gounodia* Girault **syn. n.**
Epitetracnemus Girault = *Anabrolepis*
 Timberlake **syn. n.**
Epitetratrophidea Girault = *Ectromomyiella*
 Girault **syn. n.**
Exoristobia Ashmead = *Mirsyrpophagus* Girault
syn. n., = *Parageniaspis* Masi **syn. n.**, =
Parasyrphophagus Girault **syn. n.**
Helegonatopus Perkins = *Chalcerinys* Perkins
syn. n., = *Euchalcerinys* Timberlake **syn. n.**
Hexencyrtus Girault = *Calliencyrtus* De Santis
syn. n.
Homalotylus Mayr = *Anisotylus* Timberlake
syn. n.
Hunterellus Howard = *Australzaomma* Girault
syn. n.
Hypergonatopus Timberlake = *Aulonops*
 Timberlake **syn. n.**
Isodromoides Girault = *Neocopidosomyia*
 Girault **syn. n.**
Lamennaisia Girault = *Mercetencyrtus* Trjapitzin
syn. n., = *Sabirella* Agarwal, Agarwal & Khan
syn. n.
Mahencyrtus Masi = *Tyndarichoides* Mercet
syn. n., = *Protyndarichus* Mercet **syn. n.**
Meniscocephalus Perkins = *Helmecephala* Noyes
syn. n.
Mesanusia Girault = *Blatticida* Girault **syn. n.**, =
Blatticidella Gahan & Fagan **syn. n.**
Metaphaenodiscus Mercet = *Keatsia* Girault
syn. n.
Metaphycus Mercet = *Oaphycus* Girault **syn. n.**
Neanagyrus Girault = *Anisodromus* Riek **syn. n.**
Neastymachus Girault = *Nikolskiella* Trjapitzin
syn. n., = *Pseudmicroterys* Shafee, Alam &
 Agarwal **syn. n.**
Neocharitopus Hayat, Alam & Agarwal =
Inasleya Prinsloo & Annecke **syn. n.**
Neocladella Girault = *Pteromalencyrtus* Girault
syn. n.
Ooencyrtus Ashmead = *Echthrodryinus* Perkins
syn. n., = *Tetracnemella* Girault **syn. n.**, =
Xesmatia Timberlake **syn. n.**
Parablatricida Girault = *Amaurilyma* Graham
syn. n., = *Desobius* Noyes **syn. n.**, =
Geniaspidius Masi **syn. n.**, = *Holanusia*
 Girault **syn. n.**, = *Symphycus* Masi **syn. n.**
Paratetracnemoidea Girault = *Rhinoencyrtus*
 Mercet **syn. n.**
Pentelicus Howard = *Cowperella* Girault **syn. n.**,
 = *Epaenasomyia* Girault **syn. n.**, =
Hemaenasius Ashmead **syn. n.**
Procheiloneurus Girault = *Raphaelana* Girault
syn. n.
Pseudectroma Girault = *Timberlaskia* Mercet
syn. n.
Pseudococcobius Timberlake =
Australrhypoideus Girault **syn. n.**, =
Pezaphycus Nowicki **syn. n.**
Psyllaephagus Ashmead = *Anagyropsis* Girault
syn. n., = *Calocerineloides* Girault **syn. n.**, =
Epanagyrus Girault **syn. n.**
Raffaellia Girault = *Raffaellisca* Ghesquière
syn. n.
Rhytidothorax Ashmead = *Anusomyia* Girault
syn. n., = *Ectromoides* Girault **syn. n.**, =
Mesanusomyia Girault **syn. n.**, =
Swazencyrtus Prinsloo & Annecke **syn. n.**
Syrphophagus Ashmead = *Aphidencyrtus*
 Ashmead **syn. n.**, = *Hexanusia* Girault **syn. n.**,
 = *Nesyrrpophagus* Girault **syn. n.**
Tachinaephagus Ashmead = *Phaenodiscoides*
 Girault **syn. n.**
Tetracnemoidea Howard = *Antipodencyrtus*
 Kerrich **syn. n.**, = *Ectromella* Girault **syn. n.**
- Specific**
Anarhopus sydneyensis Timberlake =
Arhopoideus semiargenteus Girault **syn. n.**
Borrowella bioculata Girault = *Borrowella*
consobrina Girault **syn. n.**
Callipteroma australia (Girault) = *Vosleria signata*
 Timberlake **syn. n.**
Ceraproceraella apus Girault = *Tropidophryne*
flandersi Compere **syn. n.**
Cerchysiella glabriscutellum (Girault) =
Mirrenencyrtus arboris Girault **syn. n.**
Cerchysiella nigrella Girault = *Ericydnella*
ashmeadi Girault **syn. n.**
Charitopus tricolor (Girault) = *Eupelmomorpha*
hawthornei Girault **syn. n.**
Cheiloneurus chlorodryini Perkins =
Cheiloneurus dubius Girault **syn. n.**
Cheiloneurus hugoi (Girault) - *Cristatothorax*
nobilis Girault **syn. n.**
Cheiloneurus novimandibularis (Girault) =
Cristatothorax mandibularis Girault **syn. n.**, =
Cristatothorax mackayensis Girault **syn. n.**, =
Cristatothorax sublimis Girault **syn. n.**, =
Cristatothorax partipes Girault **syn. n.**
Cheiloneurus pasteurii (Girault) = *Cristatothorax*
bidentimaxillae Girault **syn. n.**, =
Cristatothorax vinculum Girault **syn. n.**, =
Ephicheiloneurus albicoxa Girault **syn. n.**, =
Cristatothorax bidentimaxillae poeta Girault
syn. n.
Cheiloneurus purpureicinctus (Girault) =
Eusemionopsis centaurus Girault **syn. n.**, =
Chrysopophagus variocelli Girault **syn. n.**
Coccidoctonus dubius (Girault) =
Rhopalencyrtoidea cinctifemur Girault **syn. n.**,
 = *Paraenasomyia liszti* Girault **syn. n.**

- Coccidoxenoides perminutus* Girault =
Fulgoridicida babindae Girault **syn. n.**
Copidosoma perseverans (Girault) = *Angeliconana*
eja Girault **syn. n.**
Encyrtus argenticoxa (Girault) = *Eucomys*
hibisci Girault **syn. n.**, = *Eucomys*
aurantifasciata Girault **syn. n.**, = *Eucomys*
argentiscapus Girault **syn. n.**
Encyrtus proserpinensis (Girault) = *Eucomys*
hortensis Girault **syn. n.**
Epitetrалophidea bicinctipes Girault =
Epitetrалophidea bicinctipes emersoni Girault
syn. n.
Hexencyrtus albiclava Girault = *Hexencyrtus*
fumosipennis Girault **syn. n.**
Isodromoides triangularis Girault =
Neocopidosomyia viridiscutellum Girault
syn. n.
Neocladella compressipes Girault =
Pteromalencyrtus quadridentatus Girault
syn. n.
Neorhopus australicus Girault = *Neorhopus*
australicus aureus Girault **syn. n.**
Parablastothrix magniocolus (Girault) =
Paraenocerus albifemur Girault **syn. n.**
Parablatticida pachyscapa Girault = *Holanusia*
convexus Girault **syn. n.**
Psyllaephagus cicada (Girault) = *Paraenasomyia*
dubia Girault **syn. n.**
Psyllaephagus subgiganteus (Girault) =
Psyllaephagus usticius Riek **syn. n.**
Psyllaephagus suburbis (Girault) =
Psyllaephagus fuscus Riek **syn. n.**
Syrphophagus flavithorax (Girault) =
Nesyrrhophagus unguittatus Girault **syn. n.**, =
Hexanusia sanguinithorax Girault **syn. n.**
Tachinaephagus australiensis (Girault) =
Phaenodiscoides australiensis Girault **syn. n.**
Tassonia gloriae Girault = *Neblatticida*
tassoniaeformis Girault **syn. n.**
Tetracnemoidea bicolor (Girault) = *Arhopoideus*
tertius Girault **syn. n.**

- Adelencyrtus oceanicus* (Doutt) **comb. n.**
(Anabrolepis)
Adelencyrtus quadriguttus (Girault) **comb. n.**
(Epitetracnemus)
Adelencyrtus quinquedentatus (Girault) **comb. n.**
(Epiencyrtoides)
Aenasiella eucalypti (Dodt) **comb. n.**
(Coccidencyrtus)
Aenasiella lunlata (Girault) **comb. n.**
(Coccidoxenus)
Aenasiella sidneyi (Girault) **comb. n.**
(Encyrtoides)
Aenasioidea aligerhini (Girault) **comb. n.**
(Aphycus)
Aenasomyiella poeta (Girault) **comb. n.**
(Zaomommoencyrtus)
Ageniaspis nigra (Girault) **comb. n.**
(Leuroceroides)
Ageniaspis striatithorax (Girault) **comb. n.**
(Microrhopus)
Amira tarsata (Ashmead) **comb. n.**
(Howardiella)
Anagyrodes dei (Girault) **comb. n.** (*Paracladella*)
Anagyrodes odacon (Walker) **comb. n.**
(Encyrtus)
Anagyrodes perkinsi (Subba Rao) **comb. n.**
(Neocladia)
Anagyru bellus (Girault) **comb. n.** (*Dinocarsis*)
Anagyru cooki (Girault) **comb. n.** (*Dinocarsis*)
Anagyru darevskii (Trjapitzin) **comb. n.**
(Doliphoceras)
Anagyru fasciiscapus (Girault) **comb. n.**
(Dinocarsis)
Anagyru flavimesopleurum (Girault) **comb. n.**
(Dinocarsis)
Anagyru foersteri (Girault) **comb. n.**
(Epidinocarsis)
Anagyru lineatipes (Girault) **comb. n.**
(Dinocarsis)
Anagyru mirus (Girault) **comb. n.**
(Epidinocarsis)
Anagyru nigriflagellum (Girault) **comb. n.**
(Epidinocarsis)
Anagyru qadrii (Hayat, Alam & Agarwal)
comb. n. (*Leptanusia*)
Anagyru similis (Girault) **comb. n.**
(Epidinocarsis)
Anagyru spica (Girault) **comb. n.** (*Dinocaris*)
Anagyru subflaviceps (Girault) **comb. n.**
(Epidinocarsis)
Anagyru varithorax (Girault) **comb. n.**
(Leptomastix)
Ananusia australis (Gordh & Trjapitzin)
comb. n. (*Myrmencyrtus*)
Austrochoreia keatsi (Girault) **comb. n.**
(Chinchilla)

Proposed new combinations

(Original genus in brackets)

- Achalcerinys gorodkovi* (Myartseva) **comb. n.**
(Parasyrrhophagus)
Achalcerinys lindus (Mercet) **comb. n.**
(Parasyrrhophagus)
Achalcerinys niveipes (Girault) **comb. n.**
(Echthrobacomyia)
Adelencyrtus mayurai (Subba Rao) **comb. n.**
(Anabrolepis)
Adelencyrtus minutus (Girault) **comb. n.**
(Epitetrалophidea)

- Austroencyrtus guamensis* (Fullaway) **comb. n.**
(*Cerchysius*)
- Bacalusa tachikawai* (Shafee, Alam & Agarwal) **comb. n.** (*Doliphoceras*)
- Blastothrix siddiqii* (Bhatnagar) **comb. n.**
(*Encyrtus*)
- Carabunia dilatata* (Girault) **comb. n.**
(*Schillerana*)
- Carabunia poeta* (Girault) **comb. n.**
(*Elijahia*)
- Cerchysiella abilis* (Silvestri) **comb. n.**
(*Zeteticontus*)
- Cerchysiella amurensis* (Khlopunov) **comb. n.**
(*Zeteticontus*)
- Cerchysiella centennalis* (Erdős) **comb. n.**
(*Zeteticontus*)
- Cerchysiella glabriscutellum* (Girault) **comb. n.**
(*Mirrencyrtus*)
- Cerchysiella insularis* (Howard) **comb. n.**
(*Bothriothorax*)
- Cerchysiella kamathi* (Mani & Saraswat) **comb. n.** (*Prionomius*)
- Cerchysiella laevigata* (De Santis) **comb. n.**
(*Aratiscus*)
- Cerchysiella laeviscutum* (Thomson) **comb. n.**
(*Microterys*)
- Cerchysiella perkinsi* (Timberlake) **comb. n.**
(*Zeteticontus*)
- Cerchysiella planiscutellum* (Mercet) **comb. n.**
(*Zeteticontus*)
- Cerchysiella punctiscutellum* (Subba Rao) **comb. n.** (*Zeteticontus*)
- Cerchysiella scutellata* (Howard) **comb. n.**
(*Aratus*)
- Cerchysiella takenakai* (Tachikawa) **comb. n.**
(*Zeteticontus*)
- Cerchysiella utilis* (Noyes) **comb. n.**
(*Zeteticontus*)
- Cerchysius australis* (Girault) **comb. n.**
(*Copidosoma*)
- Charitopus bicolor* (Girault) **comb. n.**
(*Eupelmomorpha*)
- Charitopus quadricolor* (Girault) **comb. n.**
(*Eupelmomorpha*)
- Charitopus tricolor* (Girault) **comb. n.**
(*Eupelmomorpha*)
- Cheiloneuromyia planchoninae* (Howard) **comb. n.** (*Encyrtus*)
- Cheiloneurus beerwahi* (Girault) **comb. n.**
(*Epicheiloneurus*)
- Cheiloneurus burnsi* (Girault) **comb. n.**
(*Eusemionella*)
- Cheiloneurus cheles* (Walker) **comb. n.**
(*Encyrtus*)
- Cheiloneurus cinctiventris* (Girault) **comb. n.**
(*Epicheiloneurus*)
- Cheiloneurus cristatus* (Girault) **comb. n.**
(*Eusemionella*)
- Cheiloneurus hemipterus* (Girault) **comb. n.**
(*Eusemionella*)
- Cheiloneurus hugoi* (Girault) **comb. n.**
(*Cristatothorax*)
- Cheiloneurus latiscapus* (Girault) **comb. n.**
(*Cristatothorax*)
- Cheiloneurus margiscutellum* (Girault) **comb. n.**
(*Baeoanusia*)
- Cheiloneurus mazzinini* (Girault) **comb. n.**
(*Cristatothorax*)
- Cheiloneurus novimandibularis* (Girault) **comb. n.** (*Cristatothorax*)
- Cheiloneurus pasteuri* (Girault) **comb. n.**
(*Chrysopophagus*)
- Cheiloneurus purpureicinctus* (Girault) **comb. n.**
(*Chrysopophagus*)
- Cheiloneurus rara* (Girault) **comb. n.**
(*Eusemionella*)
- Cheiloneurus regis* (Girault) **comb. n.**
(*Cristatothorax*)
- Cheiloneurus viridiscutum* (Girault) **comb. n.**
(*Cristatothorax*)
- Cheiloneurus westwoodi* (Girault) **comb. n.**
(*Chrysopophagoides*)
- Coccidencyrtus albiflagellum* (Girault) **comb. n.**
(*Encyrtomyia*)
- Coccidencyrtus albitarsis* (Girault) **comb. n.**
(*Encyrtomyia*)
- Coccidencyrtus auricornis* (Girault) **comb. n.**
(*Epitetracnemus*)
- Coccidencyrtus australis* (Girault) **comb. n.**
(*Encyrtomyia*)
- Coccidencyrtus bicolor* (Girault) **comb. n.**
(*Coccidoxenus*)
- Coccidencyrtus mandibularis* (Hayat, Alam & Agarwal) **comb. n.** (*Neoadelencyrtus*)
- Coccidencyrtus secundus* (Girault) **comb. n.**
(*Encyrtomyia*)
- Coccidencyrtus wallacei* (Girault) **comb. n.**
(*Omphalencyrtus*)
- Coccidoctonus dubius* (Girault) **comb. n.**
(*Rhopalencyrtoidea*)
- Coccidoctonus lowelli* (Girault) **comb. n.**
(*Cerchysiopsis*)
- Coccidoctonus oviductus* (Girault) **comb. n.**
(*Cerchysius*)
- Coccidoctonus psyllae* (Riek) **comb. n.**
(*Echthroplexis*)
- Coccidoctonus terebratus* (Hayat, Alam & Agarwal) **comb. n.** (*Echthroplexis*)
- Coccidoxenoides peregrinus* (Timberlake) **comb. n.** (*Pauridia*)
- Coelopencyrtus asperithorax* (Rayment) **comb. n.**
(*Aphycus*)
- Coelopencyrtus crassicornis* (Szelenyi) **comb. n.**
(*Lymanera*)
- Coelopencyrtus krishnamurtii* (Mahdihassan) **comb. n.** (*Giraultella*)

- Coelopencyrtus pallidiceps* (Girault) **comb. n.**
 (*Epaenasomyia*)
Coelopencyrtus xylocopae (Girault) **comb. n.**
 (*Epaenasomyia*)
Copidosoma aeripes (Girault) **comb. n.**
 (*Zaomencyrtus*)
Copidosoma bucculatricis (Howard) **comb. n.**
 (*Pentacnemus*)
Copidosoma daccaensis (Mani) **comb. n.**
 (*Litomastix*)
Copidosoma fasciatum (Girault) **comb. n.**
 (*Pseudencyrtella*)
Copidosoma insularis (Timberlake) **comb. n.**
 (*Mesencyrtus*)
Copidosoma javae (Girault) **comb. n.**
 (*Paracopidosomopsis*)
Copidosoma javensis (Girault) **comb. n.**
 (*Copidosomopsis*)
Copidosoma lepidopterophagus (Girault)
comb. n. (*Zaomencyrtus*)
Copidosoma longiartus (Girault) **comb. n.**
 (*Liothorax*)
Copidosoma lotae (Girault) **comb. n.**
 (*Parasteropaeus*)
Copidosoma lucetius (Walker) **comb. n.**
 (*Encyrtus*)
Copidosoma manilae (Ashmead) **comb. n.**
 (*Coccidencyrtus*)
Copidosoma parkeri (Girault) **comb. n.**
 (*Helegonatopus*)
Copidosoma perseverans (Girault) **comb. n.**
 (*Paracaenocercus*)
Copidosoma salacon (Walker) **comb. n.**
 (*Encyrtus*)
Copidosoma variventris (Girault) **comb. n.**
 (*Mesocopidosomyia*)
Copidosoma walshi (Mercet) **comb. n.**
 (*Litomastix*)
Copidosomopsis arenicola (Trjapitzin) **comb. n.**
 (*Pentalitomastix*)
Copidosomopsis bohemicus (Hoffer) **comb. n.**
 (*Pentalitomastix*)
Copidosomopsis nacoliae (Eady) **comb. n.**
 (*Pseudolitomastix*)
Copidosomopsis plethoricus (Caltagirone)
comb. n. (*Pentalitomastix*)
Copidosomyia ambiguous (Subba Rao) **comb. n.**
 (*Acridencyrtus*)
Copidosomyia bhimolpornae (Tachikawa)
comb. n. (*Neochrysocephalus*)
Cowperia areolata (Walker) **comb. n.** (*Encyrtus*)
Cowperia indica (Kerrich) **comb. n.** (*Aminellus*)
Cowperia sumatraensis (Kerrich) **comb. n.**
 (*Aminellus*)
Cryptanusia gigantea (Girault) **comb. n.**
 (*Xenanusia*)
Diaphorencyrtus diaphorinae (Lin & Tao)
comb. n. (*Psyllaephagus*)
Diaphorencyrtus diaphorinae (Myartseva &
 Trjapitzin) **comb. n.** (*Aphidencyrtus*)
Diasula glabriscutellum (Girault) **comb. n.**
 (*Liothorax*)
Diasula homeri (Girault) **comb. n.**
 (*Parasyrphophagus*)
Diasula semiargentipes (Girault) **comb. n.**
 (*Parasyrphophagus*)
Doddanusia viridiflava (Dodd) **comb. n.**
 (*Anusia*)
Doliphoceras fraternus (Perkins) **comb. n.**
 (*Anagyrus*)
Doliphoceras punctifrons (Timberlake) **comb. n.**
 (*Anagyrus*)
Doliphoceras tantaleus (Perkins) **comb. n.**
 (*Anagyrus*)
Encyrtoida compressifemur (Girault) **comb. n.**
 (*Nezarhopalus*)
Encyrtus argenticoxa (Girault) **comb. n.**
 (*Eucomys*)
Encyrtus proserpinensis (Girault) **comb. n.**
 (*Eucomys*)
Encyrtus saissetiae (Yasumatsu & Yoshimura)
comb. n. (*Eucomys*)
Eotopus beneficus (Shafee) **comb. n.**
 (*Ercydnus*)
Epiblatticida aereitibiae (Girault) **comb. n.**
 (*Blatticidella*)
Epiblatticida argentipes (Girault) **comb. n.**
 (*Epitetracnemus*)
Epiblatticida caudatus (Girault) **comb. n.**
 (*Neasteropaeus*)
Epiblatticida minutissimus (Girault) **comb. n.**
 (*Microencyrtus*)
Epidinocarsis anamalaianus (Mani & Kaul)
comb. n. (*Anagyrus*)
Epidinocarsis bermudensis (Kerrich) **comb. n.**
 (*Apoanagyrus*)
Epidinocarsis diversicornis (Howard) **comb. n.**
 (*Copidosoma*)
Epidinocarsis elgeri (Kerrich) **comb. n.**
 (*Apoanagyrus*)
Epidinocarsis gaudens (Kerrich) **comb. n.**
 (*Apoanagyrus*)
Epidinocarsis lopezi (De Santis) **comb. n.**
 (*Apoanagyrus*)
Epidinocarsis malenotus (De Santis) **comb. n.**
 (*Leptomastix*)
Epidinocarsis marquesanus (Timberlake)
comb. n. (*Anagyrus*)
Epidinocarsis montivagus (De Santis) **comb. n.**
 (*Leptomastix*)
Epidinocarsis rotundiceps (Girault) **comb. n.**
 (*Dinocarsis*)
Epidinocarsis trinidadensis (Kerrich)
comb. n. (*Apoanagyrus*)
Epistenoterys mellea (Girault) **comb. n.**
 (*Gounodia*)

- Epitetracnemus extraneus* (Timberlake) **comb. n.**
(*Anabrolepis*)
- Epitetracnemus japonicus* (Ishii) **comb. n.**
(*Anabrolepis*)
- Epitetracnemus lindingaspidis* (Tachikawa) **comb. n.** (*Anabrolepis*)
- Epitetracnemus zetterstedti* (Westwood) **comb. n.**
(*Encyrtus*)
- Epitetrалophidea articulatus* (Girault) **comb. n.**
(*Ectromomyiella*)
- Epitetrалophidea magnithorax* (Girault) **comb. n.**
(*Ooencyrtus*)
- Erencyrtus keatsi* (Girault) **comb. n.**
(*Mesastymachus*)
- Exoristobia columbi* (Girault) **comb. n.**
(*Mirsyrpophagus*)
- Exoristobia funeralis* (Girault) **comb. n.**
(*Parasyrpophagus*)
- Exoristobia macrocerus* (Masi) **comb. n.**
(*Parageniaspis*)
- Gentakola trifasciata* (Saraswat) **comb. n.**
(*Comperiella*)
- Gyransoidea albiclavata* (Ashmead) **comb. n.**
(*Aphycus*)
- Gyransoidea mirzai* (Agarwal) **comb. n.**
(*Anagyru*)
- Helegonatopus apicicornis* (Timberlake) **comb. n.** (*Euchalcerinys*)
- Helegonatopus eximius* (Perkins) **comb. n.**
(*Chalcerinys*)
- Hexencyrtus bucculentus* (De Santis) **comb. n.**
(*Calliencyrtus*)
- Hunterellus brunneus* (Girault) **comb. n.**
(*Australzaomma*)
- Hunterellus mysorensis* (Mani) **comb. n.**
(*Ixodiphagus*)
- Hypergonatopus bifasciatus* (Timberlake) **comb. n.** (*Aulonops*)
- Kakaoburra angeliconini* (Girault) **comb. n.**
(*Echthrobaeccha*)
- Lamennaisia ambigua* (Nees) **comb. n.**
(*Encyrtus*)
- Lamennaisia indica* (Agarwal, Agarwal & Khan) **comb. n.** (*Sabirella*)
- Mahencyrtus aereifemur* (Girault) **comb. n.**
(*Echthronatopus*)
- Mahencyrtus comara* (Walker) **comb. n.**
(*Encyrtus*)
- Mahencyrtus gracilis* (Girault) **comb. n.**
(*Zarhopaloides*)
- Mahencyrtus longifasciatipennis* (Girault) **comb. n.** (*Zarhopaloides*)
- Mahencyrtus nitidus* (Howard) **comb. n.**
(*Encyrtus*)
- Meniscocephalus albisetosus* (Noyes) **comb. n.**
(*Helmecephala*)
- Meniscocephalus exflores* (Trjapitzin) **comb. n.**
(*Helmecephala*)
- Mesanusia ahmeadi* (Girault) **comb. n.**
(*Blatticida*)
- Metaphaenodiscus umbilicatus* (Girault) **comb. n.**
(*Keatsia*)
- Metaphycus argenteus* (Girault) **comb. n.**
(*Aphycus*)
- Metaphycus atriphragma* (Girault) **comb. n.**
(*Aphycus*)
- Metaphycus bicinctitibiae* (Girault) **comb. n.**
(*Aphycopsis*)
- Metaphycus bowensis* (Girault) **comb. n.**
(*Aphycus*)
- Metaphycus buderimi* (Girault) **comb. n.**
(*Aphycus*)
- Metaphycus fuscidorsum* (Gahan) **comb. n.**
(*Aphycus*)
- Metaphycus iohneumon* (Girault) **comb. n.**
(*Aphycus*)
- Metaphycus keatsi* (Girault) **comb. n.** (*Aphycus*)
- Metaphycus nigrivarius* (Girault) **comb. n.**
(*Aphycus*)
- Metaphycus parkeri* (Girault) **comb. n.**
(*Aenasomyiella*)
- Metaphycus sanguinithorax* (Girault) **comb. n.**
(*Aphycus*)
- Metaphycus semialbus* (Girault) **comb. n.**
(*Aphycus*)
- Metaphycus tricinctus* (Girault) **comb. n.**
(*Aphycus*)
- Metaphycus turneri* (Girault) **comb. n.** (*Aphycus*)
- Metaphycus varius* (Girault) **comb. n.**
(*Aenasioidea*)
- Metaphycus verdini* (Girault) **comb. n.**
(*Aphycus*)
- Neanagyru niger* (Riek) **comb. n.**
(*Anisodromus*)
- Neanagyru tarsius* (Riek) **comb. n.**
(*Anisodromus*)
- Neastymachus angustifrons* (Shafee, Alam & Agarwal) **comb. n.** (*Pseudmicroterys*)
- Neastymachus burski* (Shafee, Alam & Agarwal) **comb. n.** (*Pseudmicroterys*)
- Neastymachus cerococci* (Shafee, Alam & Agarwal) **comb. n.** (*Pseudmicroterys*)
- Neastymachus delhiensis* (Subba Rao) **comb. n.**
(*Microterys*)
- Neastymachus luteus* (Nikol'skaya) **comb. n.**
(*Microterys*)
- Neblatticida lotae* (Girault) **comb. n.**
(*Baeoanusia*)
- Neblatticida perfuscipennis* (Girault) **comb. n.**
(*Baeoanusia*)
- Neocharitopus crassus* (Prinsloo & Annecke) **comb. n.** (*Insleya*)
- Ooencyrtus alboantennatus* (Subba Rao) **comb. n.** (*Pentalitomastix*)
- Ooencyrtus australiensis* (Girault) **comb. n.**
(*Tetracnemella*)

- Ooencyrtus bucculatricis* (Howard) **comb. n.**
 (*Encyrtus*)
Ooencyrtus destructor (Perkins) **comb. n.**
 (*Echthrodryinus*)
Ooencyrtus euxoae (Girault) **comb. n.**
 (*Schedius*)
Ooencyrtus flavipes (Timberlake) **comb. n.**
 (*Xesmatia*)
Ooencyrtus hyalinipennis (Dodd) **comb. n.**
 (*Tetracnemella*)
Ooencyrtus inconspicuus (Girault) **comb. n.**
 (*Coccidoxenus*)
Ooencyrtus larvarum (Girault) **comb. n.**
 (*Paracopidosomopsis*)
Ooencyrtus ovidivorus (Girault) **comb. n.**
 (*Echthrodryinus*)
Ooencyrtus pallidipes (Ashmead) **comb. n.**
 (*Aphidencyrtus*)
Ooencyrtus papilionidis (Girault) **comb. n.**
 (*Stenoteropsis*)
Ooencyrtus shakespearei (Girault) **comb. n.**
 (*Coccidoxenus*)
Ooencyrtus tricolor (Girault) **comb. n.**
 (*Coccidoxenus*)
Ooencyrtus xanthogaster (Girault) **comb. n.**
 (*Echthrodryinus*)
Parablastothrix magniocolus (Girault) **comb. n.**
 (*Schedius*)
Parablastothrix uncinctipes (Girault) **comb. n.**
 (*Schedius*)
Parablatticida aphycooides (Masi) **comb. n.**
 (*Symphycus*)
Parablatticida brevicornis (Dalman) **comb. n.**
 (*Encyrtus*)
Parablatticida vidua (Masi) **comb. n.**
 (*Geniaspidius*)
Paraenasomyia australiensis (Girault) **comb. n.**
 (*Copidosoma*)
Paralitomastix bicoloricornis (Girault) **comb. n.**
 (*Coccidencyrtus*)
Paralitomastix ipswichia (Girault) **comb. n.**
 (*Coccidencyrtus*)
Paraphaenodiscus parus (Girault) **comb. n.**
 (*Encyrtus*)
Paratetracnemoidea malenotti (Mercet) **comb. n.**
 (*Rhinoencyrtus*)
Parectromoidella abnormis (Girault) **comb. n.**
 (*Dinocarsis*)
Parectromoidella holbeini (Girault) **comb. n.**
 (*Dinocarsis*)
Parectromoidella laticincta (Girault) **comb. n.**
 (*Epanusia*)
Parectromoidella lowelli (Girault) **comb. n.**
 (*Eucheiloneuropsis*)
Parectromoidella pacorus (Walker) **comb. n.**
 (*Encyrtus*)
Parectromoidella regalis (Girault) **comb. n.**
 (*Eucheiloneuropsis*)
Parectromoides varipes (Girault) **comb. n.**
 (*Parastenoterys*)
Pentelicus aeneifrons (Girault) **comb. n.**
 (*Cowperella*)
Pentelicus confusus (Ashmead) **comb. n.**
 (*Hemaenasius*)
Pentelicus varicornis (Girault) **comb. n.**
 (*Epaenasomyia*)
Procheiloneurus divinus (Girault) **comb. n.**
 (*Eusemionella*)
Prochiloneurus albivoductus (Girault) **comb. n.**
 (*Cheiloneurus*)
Prochiloneurus annulatus (Ferrière) **comb. n.**
 (*Achrysopophagus*)
Prochiloneurus aureipleurum (Girault) **comb. n.**
 (*Achrysopophagus*)
Prochiloneurus javanicus (Ferrière) **comb. n.**
 (*Achrysopophagus*)
Prochiloneurus nigricornis (Girault) **comb. n.**
 (*Achrysopophagus*)
Prochiloneurus nigriflagellum (Girault) **comb. n.**
 (*Achrysopophagus*)
Prochiloneurus taurus (Girault) **comb. n.**
 (*Achrysopophagus*)
Proleuroceroides pyrillae (Crawford) **comb. n.**
 (*Ooencyrtus*)
Protyndarichoides cinctiventris (Girault) **comb. n.**
 (*Echthrogonatopus*)
Pseudectroma europaea (Mercet) **comb. n.**
 (*Acerophagus*)
Pseudococcobius melleicorpus (Girault) **comb. n.**
 (*Australrhopoideus*)
Pseudococcobius obenbergeri (Nowicki) **comb. n.**
 (*Pezaphycus*)
Pseudococcobius quinqueguttatus (Girault) **comb. n.** (*Aphycus*)
Psyllaephagus aeneoculex (Girault) **comb. n.**
 (*Coccidoxenus*)
Psyllaephagus albiclava (Girault) **comb. n.**
 (*Anagyrus*)
Psyllaephagus anna (Girault) **comb. n.**
 (*Anagyropsis*)
Psyllaephagus arsanes (Walker) **comb. n.**
 (*Encyrtus*)
Psyllaephagus auricorpus (Girault) **comb. n.**
 (*Anagyrus*)
Psyllaephagus australiensis (Girault) **comb. n.**
 (*Anagyrus*)
Psyllaephagus brevicornis (Girault) **comb. n.**
 (*Coccidoxenus*)
Psyllaephagus burnsi (Girault) **comb. n.**
 (*Anagyropsis*)
Psyllaephagus cellinini (Girault) **comb. n.**
 (*Anagyrus*)
Psyllaephagus channingi (Girault) **comb. n.**
 (*Anagyrus*)
Psyllaephagus cicada (Girault) **comb. n.**
 (*Anagyrus*)

- Psyllaephagus cinctorum* (Girault) **comb. n.**
 (Paraenasomyia)
Psyllaephagus compactus (Girault) **comb. n.**
 (Coccidoxenus)
Psyllaephagus dius (Girault) **comb. n.**
 (Anagyryrus)
Psyllaephagus dyari (Girault) **comb. n.**
 (Anagyryrus)
Psyllaephagus emersoni (Girault) **comb. n.**
 (Anagyryrus)
Psyllaephagus grotii (Girault) **comb. n.**
 (Anagyryrus)
Psyllaephagus guttatipes (Girault) **comb. n.**
 (Anagyryrus)
Psyllaephagus hardyi (Girault) **comb. n.**
 (Blastothrix)
Psyllaephagus hegeli (Girault) **comb. n.**
 (Anagyryrus)
Psyllaephagus howardi (Girault) **comb. n.**
 (Anagyryrus)
Psyllaephagus irvingi (Girault) **comb. n.**
 (Anagyropsis)
Psyllaephagus longistylus (Girault) **comb. n.**
 (Anagyropsis)
Psyllaephagus mazzinini (Girault) **comb. n.**
 (Anagyryrus)
Psyllaephagus mercurius (Girault) **comb. n.**
 (Anagyropsis)
Psyllaephagus minutellus (Girault) **comb. n.**
 (Tetracnemella)
Psyllaephagus novipurpureus (Girault) **comb. n.**
 (Anagyryrus)
Psyllaephagus pallidipes (Girault) **comb. n.**
 (Aenasiella)
Psyllaephagus pegasus (Girault) **comb. n.**
 (Paraenasomyia)
Psyllaephagus penni (Girault) **comb. n.**
 (Anagyryrus)
Psyllaephagus punctatiscutum (Girault) **comb. n.**
 (Epanagyryrus)
Psyllaephagus purpureus (Girault) **comb. n.**
 (Anagyryrus)
Psyllaephagus ramosus (Girault) **comb. n.**
 (Calocerineloides)
Psyllaephagus richteri (Girault) **comb. n.**
 (Anagyropsis)
Psyllaephagus rubensi (Girault) **comb. n.**
 (Coccidoxenus)
Psyllaephagus semicitripes (Girault) **comb. n.**
 (Coccidoxenus)
Psyllaephagus smaragdus (Girault) **comb. n.**
 (Anagyropsis)
Psyllaephagus spondyliaspidis (Girault) **comb. n.**
 (Anagyropsis)
Psyllaephagus spongitus (Girault) **comb. n.**
 (Anagyryrus)
Psyllaephagus subgiganteus (Girault) **comb. n.**
 (Anagyryrus)
- Psyllaephagus suburbis* (Girault) **comb. n.**
 (Blastothrix)
Psyllaephagus terraefilius (Girault) **comb. n.**
 (Anagyropsis)
Psyllaephagus turbulentus (Girault) **comb. n.**
 (Anagyropsis)
Psyllaephagus turneri (Girault) **comb. n.**
 (Blastothrix)
Psyllaephagus viridiscutellum (Girault) **comb. n.**
 (Tetracnemella)
Psyllaephagus worcesteri (Girault) **comb. n.**
 (Coccidoxenus)
Psyllaephagus wundti (Girault) **comb. n.**
 (Coccidoxenus)
Psyllaephagus xuthus (Walker) **comb. n.**
 (Encyrtus)
Psyllaephagus zameis (Walker) **comb. n.**
 (Encyrtus)
Rhopalencyrtoidea perplexa (Girault) **comb. n.**
 (Nezarhopalus)
Rhopus extraclavus (Girault) **comb. n.**
 (Xanthoencyrtus)
Rhopus garibaldia (Girault) **comb. n.**
 (Xanthoencyrtus)
Rhopus keatsi (Girault) **comb. n.**
 (Scelioencyrtus)
Rhopus tricolor (Girault) **comb. n.**
 (Scelioencyrtus)
Rhytidothorax aereiscutellum (Girault) **comb. n.**
 (Anusomyia)
Rhytidothorax auratiscutum (Girault) **comb. n.**
 (Anusomyia)
Rhytidothorax ferus (Girault) **comb. n.**
 (Mesanusomyia)
Rhytidothorax laticapus (Prinsloo & Annecke)
comb. n. (Swazencyrtus)
Rhytidothorax purpureiscutellum (Girault)
comb. n. (Ectromoides)
Saprencyrtus casuarinae (Girault) **comb. n.**
 (Parasyrphophagus)
Syrphophagus africanus (Gahan) **comb. n.**
 (Aphidencyrtus)
Syrphophagus aphidivorus (Mayr) **comb. n.**
 (Encyrtus)
Syrphophagus aquacyaneus (Girault) **comb. n.**
 (Coccidoxenus)
Syrphophagus cassatus (Annecke) **comb. n.**
 (Aphidencyrtus)
Syrphophagus cinctipes (Girault) **comb. n.**
 (Neasteropaeus)
Syrphophagus feralis (Girault) **comb. n.**
 (Paraenasomyia)
Syrphophagus flavithorax (Girault) **comb. n.**
 (Nesyrphophagus)
Syrphophagus hofferi (Hayat) **comb. n.**
 (Aphidencyrtus)
Syrphophagus inquisitor (Howard) **comb. n.**
 (Encyrtus)

Syrphophagus kumaoensis (Bhatnagar) **comb. n.**
(*Coccidencyrthus*)

Syrphophagus luciani (Girault) **comb. n.**
(*Echthrobaccha*)

Syrphophagus mamitus (Walker) **comb. n.**
(*Encyrtus*)

Syrphophagus merceti (Masi) **comb. n.**
(*Encyrtus*)

Syrphophagus metallicus (Girault) **comb. n.**
(*Aratus*)

Syrphophagus nigricornis (Girault) **comb. n.**
(*Hexanusia*)

Syrphophagus obscurus (Girault) **comb. n.**
(*Neasteropaeus*)

Syrphophagus occidentalis (Girault) **comb. n.**
(*Cerchysius*)

Syrphophagus parvus (Girault) **comb. n.**
(*Cerchysiopsis*)

Syrphophagus perubius (Girault) **comb. n.**
(*Coccidoxenus*)

Syrphophagus puparia (Girault) **comb. n.**
(*Epiblatticida*)

Syrphophagus quercicola (Hoffer) **comb. n.**
(*Aphidencyrthus*)

Syrphophagus raffaellini (Girault) **comb. n.**
(*Habrolepoidea*)

Syrphophagus similis (Prinsloo) **comb. n.**
(*Aphidencyrthus*)

Syrphophagus tachikawai (Hoffer) **comb. n.**
(*Aphidencyrthus*)

Syrphophagus taeniatus (Förster) **comb. n.**
(*Encyrtus*)

Syrphophagus varicornis (Girault) **comb. n.**
(*Neasteropaeus*)

Szelenyiola prosperis (Ferrière) **comb. n.**
(*Ooencyrtus*)

Tachinaephagus australiensis (Girault) **comb. n.**
(*Phaenodiscus*)

Tachinaephagus lutheri (Girault) **comb. n.**
(*Phaenodiscoides*)

Tachinaephagus lyperosi (Ferrière) **comb. n.**
(*Cerchysius*)

Tassonia magniclava (Hayat & Subba Rao) **comb. n.**
(*Aphidencyrthus*)

Teleterebratus amplis (Girault) **comb. n.**
(*Aenasiella*)

Teleterebratus claripennis (Girault) **comb. n.**
(*Rhopalencyrtoidea*)

Tetracnemoidea bicolor (Girault) **comb. n.**
(*Ectromella*)

Tetracnemoidea procellosa (Kerrich) **comb. n.**
(*Antipodencyrthus*)

Trechnites viridiscutellum (Girault) **comb. n.**
(*Encyrtomyia*)

Tyndarichus particornis (Girault) **comb. n.**
(*Epiblatticida*)

Xenanusia flava (Girault) **comb. n.**
(*Anusia*)

Zarhopaloides auricaput (Girault) **comb. n.**
(*Oencyrtus*)

Zarhopaloides cincithorax (Girault) **comb. n.**
(*Anagyropsis*)

Proposed new status

Neocladia violacea Masi **stat. n.** (from subsp. of
Neocladia howardi Perkins)

Replacement names

Anagyryus ferus **nom. n.** for *Anagyryus flavus*
(Shafee, 1974) nec *Anagyryus flavus* Ishii
(1928).

Anagyryus inopus **nom. n.** for *Anagyryus indicus*
Shafee, Alam & Agarwal (1975) nec *Anagyryus*
indicus (Subba Rao, 1967)

Parablatticida trinidadensis **nom. n.** for
Parablatticida convexus (Noyes, 1980) nec
Parablatticida convexus (Girault, 1915)

Lectotype designations

(Present genus in brackets)

Aphycus australiensis Howard (*Aphycopsis*)

Cowperia punctata Girault (*Cowperia*)

Encyrtus arsanes Walker (*Psyllaephagus*)

Encyrtus cheles Walker (*Cheilonerurus*)

Encyrtus lucetius Walker (*Copidosoma*)

Encyrtus odacon Walker (*Anagyrodes*)

Encyrtus pacorus Walker (*Parectromoidella*)

Encyrtus salacon Walker (*Copidosoma*)

Encyrtus zameis Walker (*Psyllaephagus*)

Liothorax glabriscutellum Girault (*Diasula*)

Lutheria ajanea Girault (*Lutherisca*)

Parageniaspis macrocerus Masi (*Exoristobia*)

Parasyrphophagus casuarinae Girault
(*Saprencyrtus*)

Psyllaephagus abyssus Riek (*Psyllaephagus*)

Psyllaephagus arcatus Riek (*Psyllaephagus*)

Psyllaephagus argutus Riek (*Psyllaephagus*)

Psyllaephagus asser Riek (*Psyllaephagus*)

Psyllaephagus atavus Riek (*Psyllaephagus*)

Psyllaephagus atratus Riek (*Psyllaephagus*)

Psyllaephagus basileus Riek (*Psyllaephagus*)

Psyllaephagus bliteus Riek (*Psyllaephagus*)

Psyllaephagus bolus Riek (*Psyllaephagus*)

Psyllaephagus brachiatus Riek (*Psyllaephagus*)

Psyllaephagus clarus Riek (*Psyllaephagus*)

Psyllaephagus cornuphagus Riek (*Psyllaephagus*)

Psyllaephagus dignus Riek (*Psyllaephagus*)

Psyllaephagus discretus Riek (*Psyllaephagus*)

Psyllaephagus emarginatus Riek (*Psyllaephagus*)

Psyllaephagus excisus Riek (*Psyllaephagus*)

<i>Psyllaephagus exiguus</i> Riek (<i>Psyllaephagus</i>)	<i>Psyllaephagus paradoxus</i> Riek (<i>Psyllaephagus</i>)
<i>Psyllaephagus facetus</i> Riek (<i>Psyllaephagus</i>)	<i>Psyllaephagus quadriannellus</i> Riek
<i>Psyllaephagus facilis</i> Riek (<i>Psyllaephagus</i>)	(<i>Psyllaephagus</i>)
<i>Psyllaephagus faustus</i> Riek (<i>Psyllaephagus</i>)	<i>Psyllaephagus uncinatus</i> Riek (<i>Psyllaephagus</i>)
<i>Psyllaephagus fundus</i> Riek (<i>Psyllaephagus</i>)	<i>Psyllaephagus utilis</i> Riek (<i>Psyllaephagus</i>)
<i>Psyllaephagus funiculus</i> Riek (<i>Psyllaephagus</i>)	<i>Psyllaephagus xi</i> Riek (<i>Psyllaephagus</i>)
<i>Psyllaephagus longissimus</i> Riek (<i>Psyllaephagus</i>)	<i>Psyllaephagus ypsilon</i> Riek (<i>Psyllaephagus</i>)
<i>Psyllaephagus neoxenus</i> Riek (<i>Psyllaephagus</i>)	<i>Symphycus aphycoides</i> Masi (<i>Exoristobia</i>)

Acknowledgements

We thank Dr W. Foster (ZMCU), Mr M. J. Gijswijt (GC), Dr G. Gordh (UCR), Dr L. Masner (CNC), Dr E. G. Matthews (SAM), Dr H. Morge (IPK), Dr I. Naumann (ANIC), Dr R. Poggi (MCSN), Dr G. L. Prinsloo (PPRI), Dr S. A. Shafee (Aligarh Muslim University, India), the late Dr G. Szelenyi (HNHM), Dr V. A. Trjapitzin (ZI) and Dr C. Yoshimoto (CNC) for their very generous loans of material. Our special thanks to Dr G. Nishida (BPBM) and Dr E. E. Grissell (USNM) for arranging loans of important type – and other material and especially also to Mr E. C. Dahms (QM) for his extremely generous help in locating Girault type-material and free access to his unpublished notes on the Girault Australian encyrtid types. Also to Dr T. Sankaran (Commonwealth Institute of Biological Control, Bangalore, India) for all his help and generosity. Finally, our thanks to Dr Z. Bouček, Mr I. D. Gault, Mr T. Huddleston, Dr B. R. Subba Rao and Mrs S. Ward for their comments on the key.

We are indebted to the Royal Society and Commonwealth Foundation, London, and the Department of Science & Technology, Government of India, New Delhi, India for providing financial assistance and to Aligarh Muslim University, Aligarh, India for grant of leave to enable one of us (MH) to visit the British Museum (Natural History) where the present study was undertaken.

References

- Agarwal, M. M. 1962a. Two new species of the genus *Syrphophagus* Ashmead (Encyrtidae: Chalcidoidea) recorded from Aligarh. *Indian Journal of Entomology* **22**: 244–251.
- 1962b. *Lyka lacca* new species (Hymenoptera: Encyrtidae) a parasite of *Laccifer lacca* (Kerr.) recorded from Aligarh. *Indian Journal of Entomology* **24**: 278–281.
- 1963. New coccid inhabiting encyrtid parasites (Hymenoptera: Chalcidoidea) recorded from Aligarh. *Zeitschrift für Parasitenkunde* **22**: 394–400.
- 1965. Taxonomy of encyrtid parasites (Hymenoptera: Chalcidoidea) of Indian Coccoidea. *Acta Hymenopterologica* **2**: 37–97.
- 1966. Three undescribed genera and species of Encyrtidae (Hymenoptera: Chalcidoidea) parasitic on coccids. *Proceedings of the Indian Academy of Sciences (B)* **63**: 67–79.
- 1970. Some new chalcidoid parasites recorded from Aligarh (India) (Hym., Encyrtidae). *Mushi* **44**: 25–29.
- 1974. *Praleurocerus* proposed as a valid name for *Paraleurocerus* Agarwal nec Girault (Hym.: Chalcidoidea: Encyrtidae). *Oriental Insects* **8**: 394.
- Agarwal, M. M., Agarwal, S. & Khan, M. A. 1980. Some new chalcid parasites (Hymenoptera: Encyrtidae) recorded from India. *Abstracts XVI International Congress of Entomology, Kyoto, 1980*: 30.
- Ahmad, R. 1970. A new genus and species (*Pakencyrtus pakistanensis* gen. et sp. n.) of the family Encyrtidae from Pakistan. *Entomophaga* **15**: 237–240.
- Ahmad, R. & Ghani, M. A. 1974. *Paksimmondsius pakistanensis* gen. and sp. nov. from Pakistan. *Entomophaga* **19**: 391–395.
- Alam, S. M. 1957. Taxonomy of some encyrtid parasites (Hymenoptera, Chalcidoidea) of British scale insects. *Transactions of the Royal Entomological Society of London* **109**: 421–466.
- 1961. Undescribed encyrtid parasites (Hym.: Chalcidoidea) of Indian coccids. *Verhandlungen XI. Internationaler Kongress für Entomologie, Wien 1960*. **1**: 235–240.
- 1972. New species of Encyrtidae (Hymenoptera: Chalcidoidea) recorded from India. *Bulletin of Entomology. Entomological Society of India* **11**: 131–137.

- Alam, S. M. & Shafee, S. A.** 1982. Significance of morphological structures in the classification of Indian Encyrtidae (Chalcidoidea: Hymenoptera). *Proceedings of the Indian National Science Academy (B)* **47**: 775–798.
- Annecke, D. P.** 1962. New reared species of *Prionomastix* Mayr with synonymical notes (Hymenoptera, Encyrtidae). *South African Journal of Agricultural Science* **5**: 503–513.
- 1967. The genera *Anicetus* Howard, 1896, *Paraceraprocetus* Girault, 1920, and allies, with descriptions of new genera and species (Hymenoptera: Encyrtidae). *Transactions of the Royal Entomological Society of London* **119**: 99–169.
- 1969. Records and descriptions of African Encyrtidae. 5. (Hymenoptera: Encyrtidae). *Journal of the Entomological Society of Southern Africa* **32**: 444–459.
- 1971a. Two new African genera of Encyrtidae (Hym., Chalcidoidea). *Journal of the Entomological Society of Southern Africa* **34**: 79–87.
- 1971b. Notes on species of *Anicetus* and the description of a *Cerapteroceroides* from Ceylon (Hym., Encyrtidae). *Journal of Natural History* **5**: 257–261.
- 1974. New and little known genera and species of Encyrtidae (Hymenoptera: Chalcidoidea), mainly from the Ethiopian region. *Journal of the Entomological Society of Southern Africa* **37**: 369–386.
- Annecke, D. P. & Mynhardt, M. J.** 1970a. On the genera *Allocerellus* Silvestri 1915 and *Erencyrtus* Mahdihassan 1923 in South Africa (Hym., Encyrtidae). *Revue de Zoologie et de Botanique Africaines* **82**: 85–110.
- — 1970b. On some species of *Habrolepis* Foerster and *Adelencyrtus* Ashmead (Hym., Encyrtidae) in southern Africa and Mauritius. *Entomophaga* **15**: 127–148.
- — 1971. The species of the *zebratus*-group of *Metaphycus* Mercet (Hym., Encyrtidae) from South Africa, with notes on some extra-limital species. *Revue de Zoologie et de Botanique Africaines* **83**: 322–360.
- — 1972. The species of the *insidiosus*-group of *Metaphycus* Mercet in South Africa with notes on some extra-limital species (Hymenoptera Encyrtidae). *Revue de Zoologie et de Botanique Africaines* **85**: 227–274.
- — 1974. On the identity of *Copidosoma koehleri* Blanchard, 1940 (Hymenoptera: Encyrtidae). *Journal of the Entomological Society of Southern Africa* **37**: 31–33.
- — 1981. The species of the *asterolecanii*-group of *Metaphycus* Mercet (Hymenoptera: Encyrtidae) from South Africa with notes on some extra-limital species. *Journal of the Entomological Society of Southern Africa* **44**: 1–68.
- Annecke, D. P. & Prinsloo, G. L.** 1974. On some new and described species of arrhenophagine Encyrtidae (Hymenoptera). *Journal of the Entomological Society of Southern Africa* **37**: 35–47.
- Ashmead, W. H.** 1889. A final word about the genus *Rileya*. *Canadian Entomologist* **21**: 37–38.
- 1894. Notes on cotton insects found in Mississippi. *Insect Life* **7**: 240–247.
- 1900a. Notes on some New Zealand and Australian parasitic Hymenoptera, with descriptions of new genera and species. *Proceedings of the Linnaean Society of New South Wales* **25**: 327–360.
- 1900b. On the genera of chalcid-flies belonging to the subfamily Encyrtinae. *Proceedings of the United States National Museum* **22**: 323–412.
- 1901. Hymenoptera Parasitica. *Fauna Hawaiiensis* **1**: 277–364.
- 1902. The hymenopterous parasites of *Phenacoccus cavalliae* Ckll. *Canadian Entomologist* **34**: 301–302.
- 1904a. A list of the Hymenoptera of the Philippine Islands with descriptions of new species. *Journal of the New York Entomological Society* **12**: 1–22.
- 1904b. Descriptions of new Hymenoptera from Japan. II. *Journal of the New York Entomological Society* **12**: 146–165.
- 1904c. Classification of the chalcid flies of the superfamily Chalcidoidea, with descriptions of new species in the Carnegie Museum collected in South America by Herbert H. Smith. *Memoirs of the Carnegie Museum* **1**: i–xi, 225–551.
- 1904d. Descriptions of new genera and species of Hymenoptera from the Philippine Islands. *Proceedings of the United States National Museum* **28**: 127–158.
- 1905a. New Hymenoptera from the Philippine Islands. *Canadian Entomologist* **37**: 3–8.
- 1905b. New genera and species of Hymenoptera from the Philippines. *Proceedings of the United States National Museum* **28**: 397–413.
- Aurivillius, C.** 1888. *Arrhenophagus*, ett nytt släkte bland Encyrtiderna. *Entomologisk Tidskrift* **9**: 144–147.
- Avasthi, R. K. & Shafee, S. A.** 1980. *Neoxanthoencyrtus mymaricoides*, new genus new combination for

- Indian species of *Scelioencyrtus* (Hymenoptera: Encyrtidae). *Journal of the Bombay Natural History Society* **76**: 536–538.
- Ayyar, T. V. R.** 1932. A new chalcid with branched antennae from south India (*Tetracnemus indicus* sp. nov.). *Records of the Indian Museum* **34**: 287–288.
- 1934. First record of the chalcid genus *Comperiella* Howard from India with a description of a new species. *Records of the Indian Museum* **36**: 219–221.
- Ayyar, T. V. R. & Margabandhu, V.** 1934a. Further records of Indo-Ceylonese chalcid-flies. *Journal of the Bombay Natural History Society* **37**: 193–196.
- — 1934b. Hymenopterous parasites of economic importance in south India. *Madras Agricultural Journal* **22**: 430–446.
- Baker, G. L.** 1978. The biology of a species of *Doleschalla* (Diptera: Tachinidae), a parasite of *Pantorhytes szentivanyi* (Coleoptera: Curculionidae). *Pacific Insects* **19**: 53–64.
- Bakkendorf, D.** 1939. Verzeichnis der Trichogrammiden und Mymariden aus dem Kanjer-Moor nebst Beschreibung einer neuen Art der Aphelinidae (Hym.). *Latvijas Biologijas Biedribas Raksti* **11**: 83–86.
- 1965. Perilampidae, Eupelmidae, Encyrtidae (Hym., Chalcidoidea) from the Hansted Reservation. With descriptions of new species. *Entomologiske Meddelelser* **30**: 105–187.
- Beardsley, J. W.** 1969. The Anagryina of the Hawaiian Islands (Hym., Encyrtidae), with descriptions of two new species. *Proceedings of the Hawaiian Entomological Society* **20**: 287–310.
- 1976. A synopsis of the Encyrtidae of the Hawaiian Islands with keys to genera and species (Hymenoptera: Chalcidoidea [sic]). *Proceedings of the Hawaiian Entomological Society* **22**: 181–228.
- Beaver, R. A.** 1979. Biological studies of the fauna of pitcher plants (*Nepenthes*) in West Malaysia. *Annales de la Société Entomologique de France* **15**: 3–18.
- Bhatnagar, S. P.** 1952. Descriptions of new and record of known Chalcidoidea from India. *Indian Journal of Agricultural Science* **21**: 155–178.
- Blanchard, E. E.** 1936. Apuntes sobre Calcidoideos argentinos, nuevos y conocidos. *Revista de la Sociedad Entomológica Argentina* **8**: 7–32.
- 1940. Apuntes sobre Encirtidos argentinos. *Anales de la Sociedad Científica Argentina* **130**: 106–128.
- Bosch, R. van den, Messenger, P. S. & Gutierrez, A. P.** 1982. *An introduction to biological control*. xiv, 247 pp. New York.
- Bouček, Z.** 1970. Contribution to the knowledge of Italian Chalcidoidea, based mainly on a study at the Institute of Entomology in Turin, with descriptions of some new European species. (Hymenoptera). *Memorie della Società Entomologica Italiana* **49**: 35–102.
- 1977a. A faunistic review of the Yugoslavian Chalcidoidea (Parasitic Hymenoptera). *Acta Entomologica Jugoslavica Supplement* **13**: 1–145.
- 1977b. On *Hofferencyrtus* (gen. nov.), *Mira*, *Lyka* and some other European Encyrtidae (Hymenoptera). *Journal of Natural History* **11**: 137–154.
- Brèthes, J.** 1913. Himenópteros de la América meridional. *Anales del Museo Nacional de Historia Natural de Buenos Aires* **24**: 35–160.
- 1916. Hyménoptères parasites de l'Amérique meridional. *Anales del Museo Nacional de Historia Natural de Buenos Aires* **27**: 401–430.
- 1920. Description d'un Encyrtide nouveau du Chili. *Revista Chilena de Historia Natural* **24**: 137–139.
- 1921. Description d'un *Ceroplastes* de la république Argentine et de son parasite. *Bulletin de la Société Entomologique de France* **1921**: 79–80.
- Cameron, P.** 1884. Insects. Hymenoptera (part). *Biologia Centrali-Americana* **32**: 121–128.
- 1913. On some new and other species of Hymenoptera in the collections of the Zoological Branch of the Forest Research Institute, Dehra Dun. Part I. On the parasitic Hymenoptera reared at Dehra Dun, northern India, from the lac (*Tachardia*) and sal insects. *Indian Forest Records* **4**: 91–110.
- Chumakova, B. M.** 1957. Parasites of oyster shell scales in the Maritime Territory. [In Russian.] *Zoologicheskii Zhurnal* **36**: 533–568.
- Clausen, C. P.** 1915. Mealy bugs of citrus trees. *Bulletin of the California University Agricultural College, Berkley* **258**: 19–48.
- (Editor) 1978. Introduced parasites and predators of insect pests and weeds: A world review. *United States Department of Agriculture, Agriculture Handbook* **480**: i–vi, 1–545.
- Compere, H.** 1925. New chalcidoid (Hymenopterous) parasites and hyperparasites of the black scale, *Saissetia oleae* Bernard. *University of California Publications in Entomology* **3**: 295–326.
- 1926. New coccid-inhabiting parasites (Encyrtidae, Hymenoptera) from Japan and California. *University of California Publications in Entomology* **4**: 33–50.

- 1928. New coccid-inhabiting chalcidoid parasites from Africa and California. *University of California Publications in Entomology* **4**: 208–230.
- 1931. New encyrtid (Hymenoptera) parasites of *Pseudococcus* species from Eritraea. *University of California Publications in Entomology* **5**: 265–274.
- 1936a. A new genus and species of Encyrtidae parasitic in the pineapple mealybug, *Pseudococcus brevipes* (Ckll.). *Proceedings of the Hawaiian Entomological Society* **9**: 171–174.
- 1936b. A new species of *Habrolepis* parasitic in *Chrysomphalus aurantii* Mask. *Bulletin of Entomological Research* **27**: 493–496.
- 1937. Coccid-inhabiting parasites from Africa with descriptions of new Encyrtidae and Aphelinidae. *Bulletin of Entomological Research* **28**: 43–51.
- 1938. A report on some miscellaneous African Encyrtidae in the British Museum. *Bulletin of Entomological Research* **29**: 315–337.
- 1939. A second report on some miscellaneous African Encyrtidae in the British Museum. *Bulletin of Entomological Research* **30**: 1–26.
- 1940. A new species of *Metaphycus* (Hymenoptera, Encyrtidae) from Australia parasitic in *Eriococcus coriaceus* Maskell. *Transactions of the Royal Society of South Australia* **64**: 46–47.
- 1947a. A report on a collection of Encyrtidae with description of new genera and species. *University of California Publications in Entomology* **8**: 1–24.
- 1947b. A new species of Encyrtidae parasitic in *Coccus hesperidum* L. *Bulletin of Entomological Research* **38**: 281–283.
- 1957. Descriptions of species of *Metaphycus* recently introduced into California and some corrections. *Bollettino del Laboratorio di Entomologia Agraria 'Filippo Silvestri'* **15**: 221–230.
- Compere, H. & Annecke, D. P.** 1960. A reappraisal of *Aphycus* Mayr, *Metaphycus* Mercet, and allied genera (Hymenoptera: Encyrtidae). *Journal of the Entomological Society of Southern Africa* **23**: 375–389.
- — 1961. Descriptions of parasitic Hymenoptera and comments (Hymenopt.: Aphelinidae, Encyrtidae, Eulophidae). *Journal of the Entomological Society of Southern Africa* **24**: 17–71.
- Compere, H., Subba Rao, B. R. & Kaur, R. B.** 1960. Two species of Encyrtidae parasitic in the pink mealy bug of sugar cane in India. *Proceedings of the National Institute of Sciences of India (B)* **26**: 45–50.
- Compere, H. & Zinna, G.** 1955. Tre nuovi generi e cinque nuove specie di Encyrtidae. *Bollettino del Laboratorio di Entomologia Agraria 'Filippo Silvestri'* **14**: 94–116.
- Costa, O. G.** 1839. Monografia degli insetti ospitanti sull'Ulivo e nelle olive. *Corrispondenza zoologica destinata a diffondere nel Regno delle Due Sicilie tutto ciò che si va scoprendo entro e fuori Europa (e vice-versa) riguardante la zoologia in generale, Napoli* **1**: 91–133.
- Crawford, J. C.** 1910. Three new genera and species of parasitic Hymenoptera. *Proceedings of the United States National Museum* **38**: 87–90.
- 1911. Descriptions of new Hymenoptera, no. 3. *Proceedings of the United States National Museum* **41**: 267–282.
- 1912. Descriptions of new Hymenoptera, no. 5. *Proceedings of the United States National Museum* **43**: 163–188.
- 1913. Descriptions of new Hymenoptera, no. 6. *Proceedings of the United States National Museum* **45**: 241–260.
- 1916. Nine new species of Hymenoptera. *Insecutor Inscitiae Menstruus* **4**: 101–107.
- Dahlbom, A. G.** 1857. Svenska Små-Ichneumonernas Familjer och slükten. *Öfversigt af Kongl. Vetenskaps-Akademiens Förhandlingar* **14**: 289–298.
- Dalla Torre, K. W. von** 1897. Zur Nomenclatur der Chalcididen-Genera. *Wiener Entomologische Zeitung* **16**: 83–88.
- 1898. *Catalogus Hymenopterorum hucusque descriptorum systematicus et synonymicus*. V. Chalcididae et Proctotrupidae. 598 pp. Leipzig.
- Dalman, J. W.** 1820. Försök till Uppställning af Insect-familjen Pteromalini, i synnerhet med afscen de på de i Sverige funne Arter. *Kungliga Svenska Vetenskapsakademiens Handlingar* **41**: 123–174, 177–182.
- De Santis, L.** 1960. Descripción de un nuevo género y de una nueva especie de encirtido del Brasil (Hymenoptera: Chalcidoidea). *Actas y Trabajos del Congreso Sudamericano de Zoología* **1959(3)**: 61–65.
- 1964. Encirtidos de la Republica Argentina (Hymenoptera: Chalcidoidea). *Anales de la Comisión de Investigación Científica Provincia de Buenos Aires Gobernación* **4**: 9–422.
- 1972. Adiciones a la fauna argentina de encirtidos. III. (Hymenoptera: Chalcidoidea). *Revista Peruana de Entomologia Agrícola* **15**: 44–60.

- Dodd, A. P.** 1917. Records, etc., of Australian Chalcidoidea. *Transactions of the Royal Society of South Australia* **41**: 344–368.
- 1924. Chalcidoidea and Proctotrupoidea from Lord Howe and Norfolk Islands, with descriptions of new genera and species. *Transactions of the Royal Society of South Australia* **48**: 162–186.
- Domenichini, G.** 1951. Parassiti e iperparassiti di *Pseudococcus citri* Risso in Italia e nel Peru. *Bollettino di Zoologia Agraria e Bachicoltura* **17**: 157–180.
- Doutt, R. L.** 1948. *Arrenoclavus*, a new genus of polyembryonic Encyrtidae (Hymenoptera). *Pan-Pacific Entomologist* **24**: 145–148.
- 1951. The parasite complex of *Furcaspis oceanica*, Lindinger. *Annals of the Entomological Society of America* **43**: 501–507.
- 1952. Two new species of *Anagyris* (Encyrtidae). *Proceedings of the Hawaiian Entomological Society* **14**: 399–402.
- 1966. A taxonomic analysis of parasitic Hymenoptera reared from *Pralatoria oleae* (Colvée). *Hilgardia* **37**: 219–231.
- Dozier, H. L.** 1926. Some new Porto Rican scale parasites (Hymenoptera: Encyrtidae). *Proceedings of the Entomological Society of Washington* **28**: 97–102.
- 1927. Notes on Porto Rican scale parasites. *Journal of the Department of Agriculture, Porto Rico* **10**: 267–277.
- Eady, R. D.** 1960a. A new genus and two new species of Encyrtidae (Hymenoptera, Chalcidoidea) from the banana scab moth, *Nacoleia octasema* (Meyr.). *Bulletin of Entomological Research* **50**: 667–670.
- 1960b. *Pentalitomastix*, a new name for *Pseudolitomastix* Eady (Hymenoptera, Chalcidoidea). *Bulletin of Entomological Research* **51**: 173.
- Embleton, A. L.** 1902. On the economic importance of the parasites of Coccidae. *Transactions of the Entomological Society of London* **35**: 219–229.
- Erdős, J.** 1946a. Description of a new genus and species of the family Encyrtidae (Hymenoptera, Chalcid.). *Fragmenta Faunistica Hungarica* **9**: 1–2.
- 1946b. Genere nova et species novae chalcidoidarum (Hym.). *Annales Historico-Naturales Musei Nationalis Hungarici* **39**: 131–165.
- 1955. Megfigyelések a nád kártevőiről és azok parazitáiról. Observaciones de insectis noeovos eorumque parasitis in *Phragmite vulgari* Lam. *Állattani Közlemények* **45**: 33–48.
- 1957a. Series Encyrtidarum novarum Hungaricum. *Acta Zoologica Academiae Scientiarum Hungaricae* **3**: 5–87.
- 1957b. Miscellanea chalcidologica hungarica. *Annales Historico-Naturales Musei Nationalis Hungarici* (N.S.) **8**: 347–374.
- 1961. Symbola ad cognitionem faunae encyrtidarum et aphelinidarum Hungariae. *Acta Zoologica Academiae Scientiarum Hungariae* **7**: 413–423.
- 1963. Chalcidoidea nova vel minus cognita (Chalcidoidea). *Beiträge zur Entomologie* **13**: 283–290.
- Erdős, J. & Novicky, S.** 1955. Genera Encyrtidarum regionis palaearticae. *Beiträge zur Entomologie* **5**: 165–202.
- Fabres, G.** 1974. Une nouvelle espèce du genre *Habrolepis* (Hym. Chalcidoidea Encyrtidae) parasite de *Pseudaonidia trilobitiformis* (Homoptera Diaspididae) en Nouvelle-Calédonie. *Entomophaga* **19**: 55–60.
- Ferrière, C.** 1931. New chalcid egg-parasites from South Asia. *Bulletin of Entomological Research* **22**: 279–295.
- 1933. Notes sur les parasites de *Lyperosia exigua* de Meij. *Revue Suisse de Zoologie* **40**: 637–643.
- 1935. The chalcidoid parasites of lac insects. *Bulletin of Entomological Research* **26**: 391–406.
- 1936. Two new egg parasites of *Batocera* (Col. Lamiid.) in Malaya. *Bulletin of Entomological Research* **27**: 331–333.
- 1937. Notes on two new Oriental parasites of the coffee mealy-bug (*Pseudococcus lilacinus*). *Bulletin of Entomological Research* **28**: 315–320.
- 1947. A chalcidoid egg parasite of an Australian buprestid. *Bulletin of Entomological Research* **37**: 629–631.
- 1951. Chalcidiens Orientaux introduits en Egypte (Hym.). *Bulletin de la Société Fouad Ier d'Entomologie* **35**: 187–191.
- 1953. Encyrtids paléarctiques (Hymenoptera: Chalcidoidea) nouvelle table des genera avec notes et synonymies. *Mitteilungen der Schweizerischen Entomologischen Gesellschaft* **26**: 1–45.
- 1955a. Les parasites de la Cochenille des roseaux dans le midi de la France (Hym. Chalcid. Encyrtidae). *Bulletin de la Société Entomologique de France* **60**: 8–115.

- 1955b. Encyrtides nouveaux ou peu connus (Hym. Chalcidoidea). *Mitteilungen der Schweizerischen Entomologischen Gesellschaft* **28**: 115–136.
- 1956. Encyrtides parasites de cochenilles sur graminées. *Bollettino del Laboratorio di Zoologia Generale e Agraria della Facoltà Agraria in Portici* **33**: 350–364.
- Förster, A.** 1856. *Hymenopterologische Studien. 2. Chalcidae und Proctotrupii*. 152 pp. Aachen.
- 1860. Eine zweite centurie neuer Hymenopteren. *Verhandlungen der Naturhistorischen Vereins der Preussischen Rheinlande und Westfalens* **17**: 93–143.
- Fullaway, D. T.** 1913a. Report of the entomologist: scale insect parasites. *Report of the Hawaii Agricultural Experiment Station* **1912**: 26–31.
- 1913b. A new species of mealy-bug parasite (*Aphycus terryi*). *Proceedings of the Hawaiian Entomological Society* **2**: 281.
- 1946. Insects of Guam – II. Hymenoptera, new species of Guam Chalcidoidea. *Bulletin of the Bernice Pauahi Bishop Museum* **189**: 201–210.
- Gahan, A. B.** 1914. Descriptions of new genera and species, with notes on parasitic Hymenoptera. *Proceedings of the United States National Museum* **48**: 155–168.
- 1919. Report on a small collection of Indian parasitic Hymenoptera. *Proceedings of the United States National Museum* **56**: 513–524.
- 1920. New reared parasitic Hymenoptera from the Philippines. *Philippine Journal of Science* **17**: 343–351.
- 1922. Report on a small collection of parasitic Hymenoptera from Java and Sumatra. *Treubia* **3**: 47–52.
- 1927a. Miscellaneous descriptions of new parasitic Hymenoptera with some synonymical notes. *Proceedings of the United States National Museum* **71**: 1–39.
- 1927b. On some chalcidoid scale parasites from Java. *Bulletin of Entomological Research* **18**: 149–153.
- 1946. Eight new species of chalcid-flies of the genus *Pseudaphycus* Clausen, with a key to the species. *Proceedings of the United States National Museum* **96**: 311–327.
- 1949. Identity of the *Anagyrus* that parasitizes the pineapple mealybug (Hymenoptera: Chalcidoidea: Encyrtidae). *Proceedings of the Hawaiian Entomological Society* **13**: 357–360.
- 1951. Some synonymy and new combinations in Chalcidoidea (Hymenoptera). *Canadian Entomologist* **83**: 170–176.
- Gahan, A. B. & Fagan, M. M.** 1923. The type species of the genera of Chalcidoidea or chalcid-flies. *Bulletin of the United States National Museum* **124**: 1–173.
- Geevarghese, G.** 1977. A new species of chalcid (Hymenoptera: Encyrtidae), parasitising *Haemaphysalis bispinosa* from Karnataka, India. *Oriental Insects* **11**: 49–52.
- Ghesquière, J.** 1946. Contribution à l'étude des Microhyménoptères du Congo Belge. X–XI. *Revue de Zoologie et de Botanique Africaines* **39**: 367–373.
- 1956. Remarques taxonomiques et biologiques sur quelques Encyrtidae. *Bollettino del Laboratorio di Zoologia Generale e Agraria della Facoltà Agraria in Portici* **33**: 683–707.
- 1957. Le genre *Rhopus* Foerster nouveau pour l'Amerique du Sud (Hym. Chalcidoidea, Encyrtidae). *Neotropica* **3**: 17–22.
- 1958. *Rhopomorphus vareyellus* gen. et sp. n. (Hymenoptera: Chalcidoidea: Encyrtidae). *Proceedings of the Royal Entomological Society of London (B)* **27**: 25–29.
- Girault, A. A.** 1911. The chalcidoid parasites of the coccid *Kermes pubescens* Bogue, with descriptions of two new genera and three new species of Encyrtidae from Illinois. *Canadian Entomologist* **43**: 168–178.
- 1913a. More new genera and species of chalcidoid Hymenoptera from Paraguay. *Archiv für Naturgeschichte (A)* **79**: 51–69.
- 1913b. Some chalcidoid Hymenoptera from North Queensland. *Archiv für Naturgeschichte (A)* **79**: 70–90.
- 1913c. Diagnoses of new chalcidoid Hymenoptera from Queensland, Australia. *Archiv für Naturgeschichte (A)* **79**: 90–107.
- 1913d. A few new chalcidoid Hymenoptera from Queensland, Australia. *Bulletin of the Wisconsin Natural History Society (N.S.)* **11**: 35–48.
- 1913e. New genera and species of chalcidoid Hymenoptera in the South Australian Museum, Adelaide. *Transactions of the Royal Society of South Australia* **37**: 67–115.
- 1914a. Some new genera and species of chalcidoid Hymenoptera of the family Encyrtidae from Australia. *Societas Entomologica* **29**: 22–24, 29–30, 33–34, 36–37.
- 1914b. Records of new Chalcidoidea Encyrtinae from Australia. *Societas Entomologica* **29**: 59–60.

- 1915a. Australian Hymenoptera Chalcidoidea – VII. The family Encyrtidae with descriptions of new genera and species. *Memoirs of the Queensland Museum* **4**: 1–184.
- 1915b. Four new encyrtids from Sicily and the Philippines. *Entomologist* **48**: 184–186.
- 1915c. New genera of chalcidoid Hymenoptera. *Journal of the New York Entomological Society* **23**: 165–173.
- 1915d. Some new chalcidoid Hymenoptera from North and South America. *Annals of the Entomological Society of America* **8**: 272–278.
- 1915e. New chalcidoid Hymenoptera. *Annals of the Entomological Society of America* **8**: 279–284.
- 1916a. New Encyrtidae from North America. *Psyche* **23**: 41–50.
- 1916b. New miscellaneous chalcidoid Hymenoptera with notes on described species. *Annals of the Entomological Society of America* **9**: 291–308.
- 1916c. New Javanese chalcidoid Hymenoptera. *Proceedings of the United States National Museum* **51**: 479–485.
- 1917a. *New Javanese Hymenoptera*. 12 pp. Washington (privately published).
- 1917b. Some new Australian chalcid-flies, mostly of the family Encyrtidae. *Insector Inscitiae Menstruus* **5**: 29–37.
- 1917c. *Descriptions Stellarum Novarum*. 22 pp. (privately published).
- 1917d. *Chalcidoidea Nova Marilandensis III*. 6 pp. Glendale, Maryland (privately published).
- 1917e. New Australian chalcid-flies (Hymenoptera Chalcididae). *Insector Inscitiae Menstruus* **5**: 92–97.
- 1917f. *Descriptions Hymenopterorum Chalcidoidicarum variorum cum observationibus*. V. 16 pp. Glendale, Maryland (privately published).
- 1917g. New Australian chalcid-flies (Hymenoptera Chalcididae). *Insector Inscitiae Menstruus* **5**: 133–155.
- 1918. Several new chalcid flies from Australia. *Redia* **14**: 1–3.
- 1919a. New chalcid parasites from Malaya. *Journal of the Straits Branch of the Royal Asiatic Society* **80**: 165–168.
- 1919b. Javanese chalcid flies. *Treubia* **1**: 53–59.
- 1920a. New genera and species of chalcid-flies from Australia. *Insector Inscitiae Menstruus* **8**: 37–50.
- 1920b. New genera and species of Australian Mymaridae. *Insector Inscitiae Menstruus* **8**: 96–100.
- 1920c. New serphidoid, cynipoid and chalcidoid Hymenoptera. *Proceedings of the United States National Museum* **58**: 177–216.
- 1920d. New genera of chalcid flies from Australia. *Insector Inscitiae Menstruus* **8**: 142–146.
- 1921a. *New Animals of Australia and Old Men of the Earth*. 3pp. Brisbane (privately published).
- 1921b. Miscellaneous species of chalcid-flies from Australia (Hymenoptera, Chalcididae). *Insector Inscitiae Menstruus* **9**: 186–191.
- 1922a. New chalcid flies from eastern Australia (Hymenoptera, Chalcididae). I. *Insector Inscitiae Menstruus* **10**: 39–49.
- 1922b. New chalcid flies from eastern Australia (Hymenoptera, Chalcididae). II. *Insector Inscitiae Menstruus* **10**: 100–108.
- 1922c. New Eupelminae from Australia (Hymenoptera). *Insector Inscitiae Menstruus* **10**: 108–110.
- 1922d. New chalcid flies from Australia. *Entomologist* **55**: 205–208.
- 1922e. New chalcid flies from eastern Australia. III. (Hymenoptera). *Insector Inscitiae Menstruus* **10**: 148–154.
- 1922f. *The true remedy for head lice. Dedication of a new animal to the quality of majesty and so forth*. 1 p. Brisbane (privately published).
- 1923a. New Encyrtidae from Australia – I. *Insector Inscitiae Menstruus* **11**: 47–50.
- 1923b. Remarkable chalcid-flies collected in northern Australia by A. P. Dodd (Hymenoptera). *Insector Inscitiae Menstruus* **11**: 96–100.
- 1923c. New Encyrtidae from Australia – II. *Insector Inscitiae Menstruus* **11**: 141–148.
- 1923d. *Loves wooed and won in Australia*. 3 pp. Brisbane (privately published).
- 1923e. *Microscopitis, womanitis and new hexapods*. 7 pp. Sydney (privately published).
- 1924a. Notes and descriptions of Australian chalcid flies. I. *Insector Inscitiae Menstruus* **12**: 1–9.
- 1924b. *Homo perniciosus and new Hymenoptera*. 4 pp. Brisbane (privately published).
- 1925a. *An essay on when a fly is lovable. The ceremony of baptizing some and unlovely hate*. 4 pp. Brisbane (privately published).
- 1925b. Notes and descriptions of Australian chalcid-flies – III. *Insector Inscitiae Menstruus* **13**: 91–100.

- 1926a. *Hymenoptera minutae nova Australiensis*. 1 pp. Brisbane (privately published).
- 1926b. Notes and descriptions of Australian chalcid-flies (Hymenoptera). *Insector Inscitiae Menstruus* **14**: 58–73.
- 1926c. Notes and descriptions of Australian chalcid-flies – V. *Insector Inscitiae Menstruus* **14**: 127–133.
- 1927a. *New Australian animals so far overlooked by outsiders*. 2 pp. Brisbane (privately published).
- 1927b. Notes on and descriptions of chalcid wasps (Chalcididae) in the South Australian Museum. *Records of the South Australian Museum* **3**: 309–338.
- 1928a. *Some new Hexapods stolen from authority*. 4 pp. Brisbane (privately published).
- 1928b. Some new Philippine chalcid flies. *Philippine Journal of Science* **36**: 449–453.
- 1929a. *Description of a case of lunacy in Homo and of new six-legged Articulates*. 3 pp. Brisbane (privately published).
- 1929b. Notes on and descriptions of chalcid wasps in the South Australian Museum. Concluding paper. *Transactions of the Royal Society of South Australia* **53**: 309–346.
- 1931. *Hymenoptera, Thysanoptera nova Australiensis*. 2 pp. Brisbane (privately published).
- 1932a. *New pests from Australia X*. 6 pp. Brisbane (privately published).
- 1932b. *Hymenoptera, Thysanoptera nova Australiensis II*. 1 p. Brisbane (privately published).
- 1932c. *New lower Hymenoptera from Australia and India*. 6 pp. Brisbane (privately published).
- 1933. *Some beauties inhabiting not of commercial boudoirs but of natures bosom, notably new insects*. 5 pp. Brisbane (privately published).
- 1934a. *Miridae et Hymenoptera nova Australiensis*. 3 pp. Brisbane (privately published).
- 1934b. *New Capsidae and Hymenoptera with a note on an unmentionable*. 4 pp. Sydney (privately published).
- 1935. *Microhymenoptera Australiensis nova, mostly Chalcididae*. 4 pp. Sydney (privately published).
- 1936. *Chalcididae, Capsidae species nova Australiensis Giraulti*. 2 pp. Brisbane (privately published).
- 1938. Some new Australasian insects which are parasites (Hym. Chalcidoidea). *Revista de Entomologia. Rio de Janeiro* **8**: 80–89.
- 1939a. Description of some chalcid wasps. *Queensland Naturalist* **11**: 14–23.
- 1939b. Five new generic names in the Chalcidoidea (Australia). *Ohio Journal of Science* **39**: 324–326.
- 1940. Three new Australian encyrtid genera. *Ohio Journal of Science* **40**: 149–150.
- 1941. A new genus of Queensland Chalcidoidea. *Queensland Naturalist* **11**: 132–134.
- Gomes, J. G.** 1942. Subsídios à sistemática dos calcidoideos brasileiros. *Boletim da Escola Nacional de Agronomia* **2**: 9–45.
- Gordh, G.** 1974. A new species of *Anusoidea* Girault, 1926 (Hymenoptera: Encyrtidae) from the Philippines parasitizing *Pseudococcus citriculus* Green (Homoptera: Pseudococcidae). *Journal of Entomological Society of Southern Africa* **37**: 203–206.
- Gordh, G. & Trjapitzin, V. A.** 1978. A revision of the genus *Echthrodryinus* Perkins, 1906 (Hymenoptera: Encyrtidae). *Journal of the Kansas Entomological Society* **51**: 711–720.
- — 1979a. Notes on the genus *Zaomma* Ashmead, with a key to species (Hymenoptera: Encyrtidae). *Pan-Pacific Entomologist* **55**: 34–40.
- — 1979b. Revision of the tribe Chrysoplatycerini (Hymenoptera, Chalcidoidea, Encyrtidae). [In Russian.] *Trudy Zoologicheskogo Instituta Akademiyi Nauk SSR* **82**: 103–112.
- — 1981. Taxonomic studies of the Encyrtidae with the descriptions of new species and a new genus (Hymenoptera, Chalcidoidea). *University of California Publications in Entomology* **93**: 1–55.
- Graham, M. W. R. de V.** 1958. Notes on some genera and species of Encyrtidae (Hym., Chalcidoidea), with special reference to Dalman's types. *Entomologisk Tidskrift* **79**: 147–175.
- 1969. Synonymic and descriptive notes on European Encyrtidae (Hym., Chalcidoidea). *Polskie Pismo Entomologiczne* **39**: 211–319.
- Hall, J. C.** 1974. A new genus and species of mealybug parasite from Paraguay (Hymenoptera: Encyrtidae). *Entomological News* **85**: 19–20.
- Hayat, M.** 1970a. Three new species of Encyrtidae (Hymenoptera: Chalcidoidea) from India. *Bulletin of Entomology. Entomological Society of India* **10**: 110–115.
- 1970b. New species of Encyrtidae (Hym., Chalcidoidea) reared from 'coccids'. *Mushi* **44**: 55–63.
- 1972. Descriptions of two new genera and species of Encyrtidae (Hymenoptera, Chalcidoidea), with notes on some described species. *Acta Entomologica Bohemoslovaca* **69**: 207–214.
- 1973. A new and a known species of Encyrtidae (Hymenoptera: Chalcidoidea) from India. *Proceedings of the Zoology Society, Calcutta* **25**: 35–38.

- 1977. Notes on Indian species of *Comperiella* (Hymenoptera: Encyrtidae). *Oriental Insects* **11**: 243–250.
- 1978. On the type of *Epitetracnemus quadriguttus* Girault, 1932 (Hymenoptera: Encyrtidae). *Journal of Natural History* **12**: 33–36.
- 1979a. Indian species of *Anagyris* (Hym.: Encyrtidae) – I. *Oriental Insects* **13**: 167–188.
- 1979b. Taxonomic notes on Indian Encyrtidae (Hym.: Chalcidoidea). I. *Journal of Natural History* **13**: 315–326.
- 1980. On *Paraclausenia* gen. nov., *Metapterencyrtus* and *Neocharitopus* from India (Hymenoptera: Encyrtidae). *Journal of Natural History* **14**: 637–645.
- 1981a. Taxonomic notes on Indian Encyrtidae (Hym.: Chalcidoidea). II. *Journal of Natural History* **15**: 17–29.
- 1981b. Taxonomic notes on Indian Encyrtidae (Hymenoptera: Chalcidoidea). III. *Colemania* **1**: 13–34.
- Hayat, M., Alam, S. M. & Agarwal, M. M.** 1975. Taxonomic survey of encyrtid parasites (Hymenoptera: Encyrtidae) in India. *Aligarh Muslim University Publications (Zoological Series) on Indian Insect Types* **9**: i–iii. 1–112.
- Hayat, M. & Khanna, V.** 1977. The species of *Eugahania* (Hymenoptera: Encyrtidae) from India. *Oriental Insects* **11**: 389–393.
- Hayat, M. & Subba Rao, B. R.** 1981. A systematic catalogue of Encyrtidae (Hymenoptera: Chalcidoidea) from the Indian subcontinent. *Colemania* **1**: 103–125.
- Hayat, M. & Verma, M.** 1978. Species of *Helegonatopus* and *Parasyrrophagus* from India, with descriptions of a new genus (Hymenoptera: Encyrtidae). *Oriental Insects* **12**: 355–364.
- 1980. Description of a new genus, *Anomalencyrtus*, from India (Hym.: Encyrtidae). *Oriental Insects* **13**: 341–344.
- Hedqvist, K. J.** 1976. Descriptions of new chalcid flies (Hym., Chalcidoidea, Encyrtidae and Eulophidae) reared from *Nepticula* species collected in Sri Lanka. *Entomologisk Tidskrift* **97**: 50–54.
- Hertveztzian, E. K. & Trjapitzin, V. A.** 1974. K poznaniyu entsirtid (Hymenoptera, Encyrtidae) – parazitov koktsid trostnika *Phragmites australis* (Cav.) v Armenii. *Doklady Akademii Nauk Armyansko SSR* **58**: 248–253.
- Hoffer, A.** 1953. Encyrtidae (Hymenoptera – Chalcidoidea), quae in reservationibus naturae in Českoslovakia occurrunt. Pars 1. *Ochrana Přírody* **1953**: 83–89.
- 1954. Encyrtidae našich státních přírodních rezervací II. *Ochrana Přírody* **9**: 169–173.
- 1955. The phylogeny and taxonomy of the family Encyrtidae (Hym., Chalcidoidea). *Sborník Národního Museu v Praze* **11**: 1–22.
- 1957. Českoslvenké druhy subtribu Cheiloneurii. *Časopis České Společnosti Entomologické* **54**: 327–355.
- 1960. A revision of the Czechoslovak genera of the subfamily Encyrtinae with a reduced number of funicle segments (Hymenoptera, Chalcidoidea). *Sborník Faunistických Prací Entomologického Oddeleni Národního Museu v Praze* **6**: 93–120.
- 1963. Descriptions of new species of the family Encyrtidae from Czechoslovakia (Hym., Chalcidoidea). I. *Sborník Entomologického Oddeleni Národního Museu v Praze* **35**: 549–592.
- 1965. Prědběžná zpráva o chalcikách, parasitijících na družích čeledi Dryinidae (Hym.) na území našeho státu. *Zpravy Československé Společnosti Entomologické při CSAV* **1**(3): 12–17.
- 1976. Genre et espèces nouveaux des Encyrtides d'Algérie. *Studia Entomologica Forestalia* **2**: 101–109.
- 1980. Remarques taxonomiques sur le genre *Charitopus* (Hymenoptera, Chalcidoidea, Encyrtidae), avec une attention particulière aus espèces de l'Algérie. *Acta Entologica Bohemoslovaca* **77**: 387–393.
- Howard, L. O.** 1887. In Report of the entomologist. *Report of the United States Department of Agriculture* **1886**: 488.
- 1892. Insects of the subfamily Encyrtinae with branched antennae. *Proceedings of the United States National Museum* **15**: 361–369.
- 1895. On the Bothriothoracine insects of the United States. *Proceedings of the United States National Museum* **17**: 605–613.
- 1897. On the Chalcididae of the Island of Grenada, B. W. I. *Zoological Journal of the Linnaean Society* **26**: 129–178.
- 1898a. A new parasite of the harlequin cabbage bug. *Canadian Entomologist* **30**: 17–18.
- 1898b. On some new parasitic insects of the subfamily Encyrtinae. *Proceedings of the United States National Museum* **21**: 231–248.

- 1906. An interesting new genus and species of Encyrtidae. *Entomological News* **17**: 121–122.
- 1908. Another chalcidoid parasite of a tick. *Canadian Entomologist* **40**: 239–241.
- 1910. On some parasites reared or supposed to be reared from the eggs of the gypsy moth. *Technical Series. Bureau of Entomology, United States Department of Agriculture* **19**: i–iv, 1–12.
- Howard, L. O. & Ashmead, W. H.** 1896. On some reared parasitic hymenopterous insects from Ceylon. *Proceedings of the United States National Museum* **18**: 633–648.
- Huang, C. M.** 1980. New species of Chalcidoidea (Hymenoptera) from Fujian, China. [In Chinese with English summary.] *Acta Zootaxonomica Sinica* **5**: 430–435.
- Ishii, T.** 1923. Observations on the hymenopterous parasites of *Ceroplastes rubens* Mask., with descriptions of new genera and species of the subfamily Encyrtinae. *Bulletin of Imperial Plant Quarantine Station. Yokohama* **3**: 69–114.
- 1925. New Encyrtidae from Japan. *Technical Bulletin, Imperial Plant Quarantine Service, Yokohama* **3**: 21–30.
- 1928. The Encyrtinae of Japan. I. *Bulletin of the Imperial Agricultural Experiment Station of Japan* **3**: 79–160.
- 1940. A new genus and species of encyrtid from Java. *Kontyû* **14**: 103–105.
- Jansson, A.** 1957. Zwei neue Microhymenopteren aus Schweden, *Batrachencyrtus callidii* nov. gen. nov. sp. (Chalcidoidea Encyrtidae), *Aphanogmus annulicornis* nov. sp. (Proctotrupoidea, Calliceratae). *Entomologisk Tidskrift* **78**: 71–74.
- Jiang, De-Quan** 1982. Notes on the encyrtid parasites (Hymenoptera, Chalcidoidea) from the Chinese wax scales *Eriocerus pela* Chav. (Homoptera, Coccidae), with description of new species. [In Chinese with English summary.] *Acta Zootaxonomica Sinica* **7**: 179–186.
- Johnson, T. H. & Tieg, O. W.** 1921. On the biology and economic significance of the chalcid parasites of Australian sheep maggot-flies. *Proceedings of the Royal Society of Queensland* **33**: 99–128.
- Kerrich, G. J.** 1953. Report on Encyrtidae associated with mealy bugs on cacao in Trinidad and on some other species related thereto. *Bulletin of Entomological Research* **44**: 789–810.
- 1954. A systematic study of the encyrtid genus *Cerchysius* Westwood (Hym., Chalcidoidea). *Annals and Magazine of Natural History* (12) **7**: 371–379.
- 1963. A study of the encyrtid genus *Aminellus* Masi, with systematic notes on the related genera. *Beiträge zur Entomologie* **13**: 359–368.
- 1964a. On the European species of *Dusmetia* Mercet and a new Oriental genus (Hym., Chalcidoidea, Encyrtidae). *Entomophaga* **9**: 75–79.
- 1964b. Insects of Campbell Island (Hym. Encyrtidae). *Pacific Insects Monograph* **7**: 504–506.
- 1967. On the classification of the anagryne Encyrtidae, with a revision of some of the genera (Hymenoptera: Chalcidoidea). *Bulletin of the British Museum (Natural History)* (Entomology) **20**: 143–250.
- 1978. A revision of the dinocarsiine Encyrtidae with a study of the genus *Pelmatencyrtus* De Santis (Hymenoptera: Chalcidoidea). *Zoological Journal of the Linnaean Society* **62**: 109–159.
- 1982. Further systematic notes on tetracnemine Encyrtidae (Hym., Chalcidoidea) including a revision of the genus *Apoanagyrus* Compere. *Journal of Natural History* **16**: 399–430.
- Khan, M. A. & Agarwal, M. M.** 1976. A new species of *Leptomastix* (Hymenoptera: Encyrtidae) from Garhwal. *Oriental Insects* **10**: 377–381.
- 1978. A new species of *Cheiloneurus* (Hym.: Chalcidoidea) from Nepal with a key to the Indian and some related species. *Journal of Zoological Research, Aligarh* **2**: 21–26.
- Khan, M. Y. & Shafec, A. S.** 1975. Indian species of *Leptomastix* Foerster (Hymenoptera: Encyrtidae). *Geobios* **2**: 193–196.
- Khlopunov, E. N.** 1979. Palaeartic representative of the encyrtid genus *Pentelicus* Howard, 1895 (Hymenoptera, Encyrtidae). [In Russian.] *Entomologicheskoe Obozrenie* **58**: 394–398. [English translation: *Entomological Review, Washington* **58**(2): 140–144.]
- Kryger, J. P.** 1951. Notes on chalcids II. *Entomologiske Meddelelser* **26**: 98–121.
- Latreille, P. A.** 1809. *Genera Crustaceorum et Insectorum*. **4**, 399 pp. Parisiis et Argentorati.
- 1810. *Considérations générales sur l'ordre naturel des animaux composant les classes des Crustacés, des Arachnides et des Insectes*. 444 pp. Paris.
- Lin, S. J. & Tao, C. C.** 1979. *Psyllaephagus diaphorinae*, new species parasitising *Diaphorina citri* in Taiwan, China (Hymenoptera; Encyrtidae). *Quarterly Journal of Taiwan Museum* **32**: 117–121.
- Loginovskaya, T. V.** 1981. A review of Holarctic encyrtids of the genus *Parablastothrix* Mercet (Hymenoptera, Encyrtidae). [In Russian.] *Entomologicheskoe Obozrenie* **60**: 160–165. [English translation: *Entomological Review, Washington* **60**: 147–153.]

- 1983. A new species encyrtids of the genus *Ageniaspis* Dahlbom, 1857 (Hymenoptera, Encyrtidae) from Viet Nam. [In Russian.] *Entomologicheskoe Obozrenie* **61**: 610–611.
- Mahdihassan, S.** 1923. Classification of lac insects from physiological standpoint. *Journal of the Science Association of the Maharaja's College, Vizianagram, India* **1**: 47–99.
- 1931. The symbiotes of some important lac insects. *Archiv für Protistenkunde* **71**: 164–178.
- 1957. *Giraultella krishnamurtii* n. sp. *Current Science* **26**: 182.
- Mani, M. S.** 1935. A new encyrtid chalcid genus *Krishnieriella* gen. nov. from India. *Records of the Indian Museum* **37**: 421–423.
- 1939. Descriptions of new and records of some known chalcidoid and other hymenopterous parasites from India. *Indian Journal of Entomology* **1**: 69–99.
- 1941. Studies on Indian parasitic Hymenoptera I. *Indian Journal of Entomology* **3**: 25–36.
- Mani, M. S., Dubey, O. P., Kaul, B. K. & Saraswat, G. G.** 1973. On some Chalcidoidea from India. *Memoirs of the School of Entomology, St John's College* **2**: 1–128.
- 1974. Descriptions of some new and new records of some known Chalcidoidea (Hymenoptera) from India. *Memoirs of the School of Entomology, St John's College* **3**: 1–108.
- Masi, L.** 1917a. A new species of *Cerapterocerus* Westw. (*Eusemion* Dahlb.) (Encyrtidae, Chalcidoidea) from Italy. *Entomologist's Monthly Magazine* **53**: 80.
- 1917b. Chalcididae of the Seychelles islands. *Novitates Zoologicae* **24**: 121–230.
- 1919. Calcididi del Giglio. *Annali del Civico di Storia Naturale de Genova* **48**: 277–337.
- 1926. H. Sauter's Formosa-Ausbeute. Chalcididae (Hym.). *Knowia* **5**: 1–20, 170–178, 264–279.
- Mayr, G. L.** 1876. Die europäischen Encyrtiden. *Verhandlungen der Zoologisch-Botanischen Gesellschaft in Wien* **25**: 675–778.
- Menzel, A.** 1855. *Dicelloceras vibrans*, Wippende Schaufelfühlerwespe. *Stettiner Entomologische Zeitung* **16**: 270–274.
- Mercet, R. G.** 1916a. Los parasitos del 'pol-roig'. *Revista de la Academia de Ciencias Exactas, Fisicas y Naturales de Madrid* **14**: 776–788.
- 1916b. Calcídidos de España. *Boletín de la Real Sociedad Española de Historia Natural* **16**: 112–117.
- 1916c. Un Encyrtino nuevo de España. *Boletín de la Real Sociedad Española de Historia Natural* **16**: 372–376.
- 1917a. Especies españolas del género *Aphycus*. *Boletín de la Real Sociedad Española de Historia Natural* **17**: 128–139.
- 1917b. Un nuevo género de Encirtinos. *Boletín de la Real Sociedad Española de Historia Natural* **17**: 203–206.
- 1917c. Encirtinos de España. *Boletín de la Real Sociedad Española de Historia Natural* **17**: 268–271.
- 1917d. Generos nuevos de Encirtinos (Himenópteros Chalcídidos). *Boletín de la Real Sociedad Española de Historia Natural* **17**: 537–544.
- 1918. Géneros nuevos de Encirtinos de España. *Boletín de la Real Sociedad Española de Historia Natural* **18**: 234–241.
- 1919a. Encirtinos de España. *Boletín de la Real Sociedad Española de Historia Natural* **19**: 96–102.
- 1919b. Notas sobre Encirtidos (Himenópteros, Calcídidos). *Boletín de la Real Sociedad Española de Historia Natural* **19**: 470–478.
- 1921. *Fauna Iberica. Himenopteros Fam. Encirtidos*. 727 pp. Madrid.
- 1922a. Notas sobre Encirtidos de Java. *Boletín de la Real Sociedad Española de Historia Natural* **22**: 150–157.
- 1922b. Encirtidos de Europe Central nuevos o poco conocidos. *Boletín de la Real Sociedad Española de Historia Natural* **22**: 294–299.
- 1923a. Encirtidos de Europa Central, nuevas o poco conocidos (2a nota). *Boletín de la Real Sociedad Española de Historia Natural* **23**: 286–292.
- 1923b. Adiciones à la fauna española de Encirtidos. la nota. *Boletín de la Real Sociedad Española de Historia Natural* **22**: 474–481.
- 1924. Los géneros *Leptomastidea*, *Callipteroma* y *Gyranusa*. *Boletín de la Real Sociedad Española de Historia Natural* **24**: 252–260.
- 1925a. El género *Aphycus* y sus afines. *Eos, Madrid* **1**: 7–31.
- 1925b. Adiciones a la fauna española de Encirtidos (Hym. Chalc.). 5a nota. *Eos, Madrid* **1**: 321–337.
- 1926. Los géneros *Chalcaspis* How. y *Eugahania* nuevo (Hym. Chalc.). *Eos, Madrid* **2**: 43–48.
- 1929. Los géneros *Prochiloneurus* y *Achrysopophagus*. *Eos, Madrid* **5**: 359–363.
- Motschulsky, V. de** 1859. *Études entomologiques*. **8**, 187 pp. Helsingors.

- 1863. Essai d'un catalogue des insectes de l'Ile Ceylon (Suite). *Byulleten' Moskovskogo Obshchestva Ispytateley Prirody* **36**(3): 1–153.
- Myartseva, S. N.** 1979. A new species of the genus *Anathrix* (Hymenoptera, Encyrtidae) from Thailand. [In Russian.] *Zoologicheskii Zhurnal* **58**: 1746–1748.
- 1980. A new genus and new species of encyrtids (Hymenoptera, Chalcidoidea) from Turkmenia. [In Russian.] *Zoologicheskii Zhurnal* **59**: 722–727.
- 1983. New species of parasitic Hymenoptera (Hymenoptera, Encyrtidae). [In Russian.] *Izvestiya Akademii Nauk Turkmenskoy SSR* **1983** (1): 64–68.
- Myartseva, S. N. & Trjapitzin, V. A.** 1978. *Aphidencyrtus diaphorinae* sp. n. (Hymenoptera, Encyrtidae), a parasite reared from *Diaphorina citri* in Vietnam. [In Russian.] *Zoologicheskii Zhurnal* **57**: 793–795.
- 1979. A new species of parasitic Hymenoptera of the genus *Metaphaenodiscus* (Hymenoptera, Encyrtidae) from Thailand. [In Russian.] *Zoologicheskii Zhurnal* **58**: 1238–1240.
- Narayanan, E. S.** 1960. Two new species of chalcidoid parasites from India. *Proceedings of the Indian Academy of Science* **52**: 119–123.
- 1961. New record and description of new species of parasites of San Jose scale. *Proceedings of the National Institute of Sciences of India* (B) **26** supplement: 20–29.
- Narayanan, E. S. & Subba Rao, B. R.** 1960. New species of encyrtid and braconid parasites. *Indian Journal of Entomology* **22**: 75–79.
- Novickij, S.** 1926. Generis novi Encyrtidarum et detrito litorali prope Albin flumen, in Bohemia Centr. exclusi descriptio (Hymen. Chalcid. Enc.). *Sborník Entomologického Oddělní Národního Musea v Praze* **4**: 105–110.
- Noyes, J. S.** 1977. The encyrtid genus *Amira*, parasites of spider eggs (Hymenoptera). *Systematic Entomology* **2**: 49–51.
- 1978. A revision of the encyrtid genus *Callipteroma* Motchulsky (Hymenoptera: Encyrtidae). *Australian Journal of Zoology* **26**: 539–553.
- 1979. The West Indian species of Encyrtidae described by L. D. Howard, 1894 and 1897 (Hymenoptera, Chalcidoidea). *Systematic Entomology* **4**: 143–169.
- 1980. A review of the genera of Neotropical Encyrtidae (Hymenoptera: Chalcidoidea). *Bulletin of the British Museum (Natural History)* (Entomology) **41**: 107–253.
- 1982. A new species of *Zeteticontus* Silvestri (Hymenoptera: Encyrtidae) from Israel and Kenya, a parasite of *Carpophilus hemipterus* (L.) (Coleoptera: Nitidulidae). *Bulletin of Entomological Research* **72**: 457–460.
- Noyes, J. S. & Chua, T. H.** 1977. Descriptions of two new species of *Cheiloneurus* from Malaysia (Hymenoptera: Encyrtidae). *Oriental Insects* **11**: 541–546.
- Peck, O.** 1963. A catalogue of the Nearctic Chalcidoidea (Insecta; Hymenoptera). *Canadian Entomologist Supplement* **30**: 1–1092.
- Perkins, R. C. L.** 1906. Leaf-hoppers and their natural enemies (VIII). *Bulletin. Hawaiian Sugar Planters' Association Experiment Station* (Entomology Series) **1**: 239–267.
- 1910. Supplement to Hymenoptera. *Fauna Hawaiiensis* **2**: 600–686.
- 1912. Parasites of insects attacking sugar cane. *Bulletin. Hawaiian Sugar Planters' Association Experiment Station* (Entomology Series) **10**: 1–27.
- Prinsloo, G. L.** 1976a. On the species of *Paraphaenodiscus* Girault (Hymenoptera: Encyrtidae) from the Ethiopian region with comments on the genus. *Journal of the Entomological Society of Southern Africa* **39**: 159–173.
- 1976b. The Australian species of *Microterys* Thomson (Hymenoptera: Encyrtidae). *Journal of the Australian Entomological Society* **14**: 409–423.
- 1977. On the encyrtid parasitoids (Hymenoptera: Chalcidoidea) of lac insects (Hemiptera: Lacciferidae) from southern Africa. *Journal of the Entomological Society of Southern Africa* **40**: 47–72.
- 1979. On the species of *Zaomma* Ashmead (Hymenoptera: Encyrtidae) from the Ethiopian region. *Journal of the Entomological Society of Southern Africa* **42**: 65–75.
- 1981. On the encyrtid parasites (Hymenoptera: Chalcidoidea) associated with psyllids (Hemiptera: Psylloidea) in southern Africa. *Journal of the Entomological Society of Southern Africa* **44**: 199–244.
- 1982. Two new South African species of *Timberlakia* Mercet (Hymenoptera: Encyrtidae), parasitic in mealybugs on citrus. *Journal of the Entomological Society of Southern Africa* **45**: 221–225.
- Prinsloo, G. L. & Annecke, D. P.** 1978a. The new species of *Ooencyrtus* (Hym. Encyrtidae) parasitic in *Othreis fullonia* (Clerck) (Lep. Noctuidae) from new Caledonia and Western Samoa. *Cahiers de l'Office de la Recherche Scientifique et Technique Outre-Mer* (Série Biologie) **13**: 41–44.

- — 1978b. On some new and described Encyrtidae (Hymenoptera: Chalcidoidea) from the Ethiopian region. *Journal of the Entomological Society of Southern Africa* **41**: 311–331.
- — 1979. A key to the genera of Encyrtidae from the Ethiopian region, with descriptions of three new genera (Hymenoptera: Chalcidoidea). *Journal of the Entomological Society of Southern Africa* **42**: 349–382.
- Prinsloo, G. L. & Mynhardt, M. J.** 1982. New species of coccoid-inhabiting Encyrtidae (Hymenoptera: Chalcidoidea) from South Africa. II. *Phytophylactica* **14**: 35–41.
- Ratzeburg, J. T. C.** 1844. *Die Ichneumoniden der Forstinsecten in entomologischer und forstlicher Beziehung*. 1, 224 pp. Berlin.
- 1848. *Die Ichneumoniden der Forstinsecten in entomologischer und forstlicher Beziehung*. 2, 238 pp. Berlin.
- Rayment, T.** 1949. New bees and wasps. Part IX. *Victorian Naturalist, Melbourne* **65**: 247–254.
- Riek, E. F.** 1962a. A new encyrtid genus parasitic on bug eggs. *Proceedings of the Linnaean Society of New South Wales* **87**: 151–155.
- 1962b. A new species of *Echthroplexis*, an encyrtid hyperparasite of lerp-forming psyllids on eucalypts (Hymenoptera, Chalcidoidea). *Proceedings of the Linnaean Society of New South Wales* **87**: 189–190.
- 1962c. A new encyrtid (Hymenoptera, Chalcidoidea) genus of parasites of lerp-forming psyllids on *Eucalyptus*. *Proceedings of the Linnaean Society of New South Wales* **87**: 283–285.
- 1962d. The Australian species of *Psyllaephagus* (Hymenoptera: Encyrtidae), parasites of psyllids (Homoptera). *Australian Journal of Zoology* **10**: 684–757.
- Riley, C. V., Ashmead, W. H. & Howard, L. O.** 1894. Report upon the parasitic Hymenoptera of the island of St Vincent. *Zoological Journal of the Linnaean Society* **25**: 56–254.
- Risbec, J.** 1951. Les Chalcidoïdes de l'Afrique occidentale française. II. Les Microgasterinae de l'Afrique occidentale française. *Mémoires de l'Institut Français d'Afrique Noire* **13**: 7–409.
- 1954. Chalcidoïdes et Proctotrupoïdes de l'Afrique occidentale française (4^e supplément). *Bulletin de l'Institut Français d'Afrique Noire (A)* **16**: 1035–1092.
- 1956. *Australomalotylus rageneau* n. sp., Encyrtidae parasite de *Sarcophaga* sp. en Nouvelle Calédonie. *Annales de Parasitologie Humaine et Comparée* **30**: 169–173.
- 1958. Encyrtidae de Madagascar (Hym. Chalcid.). *Bulletin de l'Académie Malgache* **35**: 17–44.
- Rosen, D.** 1969. A systematic study of the genus *Acerophagus* E. Smith, with descriptions of new species (Hym., Encyrtidae). *Hilgardia* **40**: 41–72.
- 1976. The species of *Microterys* (Hymenoptera: Encyrtidae). An annotated world list. *Annals of the Entomological Society of America* **69**: 479–485.
- Rosen, D. & Alon, A.** 1983. Taxonomic and biological studies of *Diversinervus cervantesi* (Girault) (Hymenoptera: Encyrtidae), a primary parasite of soft scale insects. *Contributions of the American Entomological Institute* **20**: 336–362.
- Sands, D. P. A. & Snowball, G. T.** 1980. *Comperiella pia* (Girault) (Hymenoptera: Encyrtidae) a parasitoid of the circular black scale (*Chrysomphalus ficus* Ashmead) from Queensland. *Journal of the Australian Entomological Society* **19**: 41–46.
- Saraswat, G. G. & Mukerjee, M. K.** 1975. Records of some known and descriptions of new species of chalcids (Hymenoptera) from India. *Memoirs of the School of Entomology, St John's College* **4**: 35–62.
- Schellenberg, J. R.** 1803. *Genres des mouches diptères*. 95 pp. Zurich.
- Schmiedeknecht, O.** 1909. Hymenoptera fam. Chalcididae. *Genera Insectorum* **97**, 550 pp. Brussels.
- Shafee, S. A.** 1971. Two new species of Encyrtidae (Hymenoptera: Chalcidoidea) from India. *Bulletin of Entomology, Entomological Society of India* **12**: 48–51.
- 1972. A new genus of Encyrtidae (Hymenoptera, Chalcidoidea) from India. *Journal of Entomology (B)* **41**: 159–162.
- 1974. Species of the genera *Tachardiaephagus* Ashmead, 1904 and *Mashhoodia* Shafee, 1972 (Hymenoptera: Encyrtidae) from India. *Indian Journal of Entomology* **34**: 325–329.
- 1981. A new species of *Erycydnus* Walker (Hymenoptera: Encyrtidae) from India. *Oriental Insects* **15**: 57–59.
- Shafee, S. A., Alam, S. M. & Agarwal, M. M.** 1975. Taxonomic survey of encyrtid parasites (Hymenoptera: Encyrtidae) in India. *Aligarh Muslim University Publications (Zoological Series) on Indian Insect Types* **10**: i–iii, 1–125.
- Silvestri, F.** 1915a. Contributo alla conoscenza degli insetti dell'olivo dell'Eritrea e dell'Africa meridionale. *Bollettino del Laboratorio di Zoologia Generale e Agraria della R. Scuola Superiore d'Agricoltura* **9**: 240–334.

- 1915b. Descrizione di nuovi Imenotteri Chalcididi africani. *Bollettino del Laboratorio di Zoologia Generale e Agraria della R. Scuola Superiore d'Agricoltura* **9**: 337–377.
- Six, G. A.** 1876. Opmerkingen omtrent zes markwaardige inlandsche Pteromalinen eb eene Proctotrupide. *Tijdschrift voor Entomologie* **19**: 133–137.
- Smith, E. A.** 1880. Biological and other notes on *Pseudococcus aceris*. *North American Entomologist* **1**: 73–87.
- Smith, J. B.** 1888. Ento. Soc. Washington, June 7th 1888. *Entomologica Americana* **4**: 80.
- Subba Rao, B. R.** 1957. Some new species of Indian Hymenoptera. *Proceedings of the Indian Academy of Sciences (B)* **46**: 376–390.
- 1965a. A key to species of *Anicetus* Howard, 1896 (Hymenoptera: Encyrtidae) and descriptions of new species from India. *Proceedings of the Royal Entomological Society of London (B)* **34**: 71–75.
- 1965b. A new genus of Encyrtidae from India. *Proceedings of the Royal Entomological Society of London (B)* **34**: 150–152.
- 1966. *Comperiella aspidiotiphaga* new species from India (Encyrtidae Hymenoptera). *Mushi* **39**: 135–138.
- 1967. Description of some new species of encyrtids from India. *Bulletin of Entomology, Entomological Society of India* **8**: 1–7.
- 1970. A redescription of *Exoristobia* Ashmead 1904 and description of two new species (Hymenoptera: Encyrtidae). *Proceedings of the Royal Entomological Society of London (B)* **39**: 109–113.
- 1971. New genera and species of encyrtids (Hymenoptera: Encyrtidae). *Journal of Natural History* **5**: 209–224.
- 1972. On *Zeteticontus* Silvestri with descriptions of three new species (Hymenoptera: Encyrtidae). *Entomophaga* **17**: 179–195.
- 1973. Description of two new species of *Carabunia* Waterston (Hymenoptera: Encyrtidae). *Oriental Insects* **7**: 485–489.
- 1976. Description of a new species of *Anthemus* Howard (Hymenoptera: Encyrtidae) parasitic on *Diaspidiotus prunorum* Liang (Coccoidea: Diaspididae) with some new combinations and synonyms. *Journal of Natural History* **10**: 685–689.
- 1977. Two new species of parasites from wax scale *Ceroplastes* sp. and a new genus and species from *Saccharicoccus sacchari* (Ckll.) of potential importance from India (Hymenoptera: Encyrtidae). *Proceedings of the Indian Academy of Sciences (B)* **85**: 13–20.
- 1978. A revision of *Tachinaephagus* Ashmead (Hymenoptera: Encyrtidae) with descriptions of four new species. *Bulletin of Entomological Research* **68**: 65–73.
- 1979. Taxonomic studies on some encyrtid genera (Hymenoptera: Chalcidoidea: Encyrtidae). *Oriental Insects* **13**: 139–148.
- Subba Rao, B. R. & Hayat, M.** 1979. A note on the genus *Scelioencyrtus* Girault and description of a new genus *Hamusencyrtus* (Hymenoptera: Encyrtidae) from India. *Journal of Entomological Research* **2**: 1–4.
- Subba Rao, B. R. & Rai, P. S.** 1970. Studies on the Indian species of the genus *Anagyrus* Howard, 1896 (Hymenoptera: Encyrtidae). *Beiträge zur Entomologie* **20**: 85–96.
- Sugonjaev, E. S.** 1960. On the species of the genera allied to *Aphycus* Mayr (Hymenoptera, Chalcidoidea) from the European part of the USSR. [In Russian.] *Entomologicheskoe Obozrenie* **39**: 364–383. [English translation: *Entomological Review, Washington* **39**: 235–364.]
- 1964. Palaearctic species of the genus *Blastothrix* Mayr (Hymenoptera, Chalcidoidea) with remarks on their biology and economic importance. Part 1. [In Russian.] *Entomologicheskoe Obozrenie* **43**: 368–390. [English translation: *Entomological Review, Washington* **43**: 189–198.]
- Sugonjaev, E. S. & Gordh, G.** 1981. Taxonomy and trophic relations of encyrtids of the genus *Encyrtus* Latr. (Hymenoptera, Encyrtidae) of the Holarctic region. [In Russian.] *Entomologicheskoe Obozrenie* **60**: 883–897. [English translation: *Entomological Review, Washington* **60** (4): 124–129.]
- Swezey, O. H.** 1946. Insects of Guam. – II. Notes on some Guam Chalcidoidea. *Bulletin of the Bernice Pauahi Bishop Museum* **189**: 211–219.
- Szelényi, G.** 1971. Data to the Mongolian encyrtid fauna (Hym., Chalcidoidea). I. Ergebnisse der Zoologischen Forschungen von Dr Z. Kaszab in der Mongolei. Nr. 272. *Acta Zoologica Academiae Scientiarum Hungaricae* **17**: 387–396.
- 1972a. Data to the Mongolian encyrtid-fauna (Hymenoptera: Chalcidoidea). II. Ergebnisse der zoologischen Forschungen von Dr Z. Kaszab in der Mongolei (No. 286). *Acta Zoologica Academiae Scientiarum Hungaricae* **18**: 117–127.

- 1972b. Neue Encyrtiden aus Ungarn (Hymenoptera, Chalcidoidea). *Annales Historico-Naturales Musei Nationalis Hungarici* **64**: 347–353.
- Tachikawa, T.** 1955. A new genus of Encyrtidae parasitic on a psyllid (Hym.). *Kontyû* **23**: 63–67.
- 1956. A revision of the species of the genus *Eugahania* Mercet, 1926 (Hymenoptera: Encyrtidae). *Kontyû* **24**: 161–165.
- 1963. Revisional studies on the Encyrtidae of Japan (Hymenoptera: Chalcidoidea). *Memoirs of Ehime University* (6) **9**: 1–264.
- 1968. Discovery of the genus *Anusioidea* Girault from Asia (Hymenoptera: Chalcidoidea – Encyrtidae). *Transactions of the Shikoku Entomological Society* **9**: 117–118.
- 1970. Notes on some Japanese species of Encyrtidae (Hymenoptera: Chalcidoidea). *Transactions of the Shikoku Entomological Society* **10**: 100–106.
- 1974. Notes on *Arhopoideus brevicornis* Girault, the type species of the genus (Hymenoptera: Chalcidoidea – Encyrtidae). *Transactions of the Shikoku Entomological Society* **12**: 23–31.
- 1978. A new species of *Pseudohomalopoda* from Indonesia (Hymenoptera: Chalcidoidea – Encyrtidae). *Transactions of the Shikoku Entomological Society* **14**: 65–67.
- 1979a. A revision of the genus *Pseudohomalopoda* Girault with the description of a new genus (Hymenoptera: Chalcidoidea – Encyrtidae). *Transactions of the Shikoku Entomological Society* **14**: 163–170.
- 1979b. A new genus and species of Encyrtidae (Hymenoptera) parasitic on *Chrysopa* (Neuroptera) in Thailand. *Transactions of the Shikoku Entomological Society* **14**: 171–175.
- 1981. Hosts of encyrtid genera in the world (Hymenoptera: Chalcidoidea). *Memoirs of the College of Agriculture, Ehime University* **25**: 85–110.
- Tachikawa, T., Paik, W. H. & Paik, J. C.** 1981. A new species of the genus *Caenohomalopoda* Tachikawa (Hymenoptera: Encyrtidae) parasitic on *Odonaspis secreta* (Homoptera: Diaspididae) from Korea. *Transactions of the Shikoku Entomological Society* **15**: 183–186.
- Tachikawa, T. & Valentine, E. W.** 1969a. A new species of *Aphycomorpha* (Hymenoptera: Encyrtidae) parasitic on a diaspine scale from New Zealand. *New Zealand Journal of Science* **12**: 535–540.
- 1969b. A new genus of Encyrtidae from New Zealand (Hymenoptera: Chalcidoidea). *New Zealand Journal of Science* **12**: 546–552.
- 1971. Notes on the *Arhopoideus*-group (Hymenoptera; Chalcidoidea – Encyrtidae). *Transactions of the Shikoku Entomological Society* **11**: 21–30.
- Tandon, P. L. & Srivastava, R. P.** 1980. New records of parasites and predators of important insect pests of mango. *Entomon* **5**: 243–244.
- Thomson, C. G.** 1876. *Skandinaviens Hymenoptera*. **4**, 192 pp. Lund.
- Timberlake, P. H.** 1916. Revision of the parasitic hymenopterous insects of the genus *Aphycus* Mayr, with notice of some related genera. *Proceedings of the United States National Museum* **50**: 561–640.
- 1918. New genera and species of Encyrtinae from California parasitic in mealybugs (Hymenoptera). *University of California Publications in Entomology* **1**: 347–367.
- 1919a. Revision of the parasitic chalcidoid flies of the genera *Homalotylus* Mayr and *Isodromus* Howard, with descriptions of two closely related genera. *Proceedings of the United States National Museum* **56**: 133–194.
- 1919b. Descriptions of new genera and species of Hawaiian Encyrtidae (Hymenoptera). *Proceedings of the Hawaiian Entomological Society* **4**: 197–231.
- 1920. Descriptions of new genera and species of Hawaiian Encyrtidae (Hymenoptera), II. *Proceedings of the Hawaiian Entomological Society* **4**: 409–437.
- 1922a. Descriptions of new genera and species of Hawaiian Encyrtidae (Hymenoptera), III. *Proceedings of the Hawaiian Entomological Society* **5**: 135–167.
- 1922b. Notes on the identity and habits of *Blepyrus insularis* Cameron (Hymenoptera, Chalcidoidea). *Proceedings of the Hawaiian Entomological Society* **5**: 167–173.
- 1923. Descriptions of two new species of Encyrtidae from Mexico reared from mealybugs (Hym. Chalcidoidea). *Proceedings of the Hawaiian Entomological Society* **5**: 323–333.
- 1924. Descriptions of new chalcid-flies from Hawaii and Mexico (Hymenoptera). *Proceedings of the Hawaiian Entomological Society* **5**: 395–417.
- 1926. Miscellaneous new chalcid-flies of the hymenopterous family Encyrtidae. *Proceedings of the United States National Museum* **69**: 1–34.
- 1929. Three new species of the hymenopterous family Encyrtidae from New South Wales. *University of California Publications in Entomology* **5**: 5–18.

- 1932. Three new parasitic Hymenoptera from the Indo-Malayan region. *Proceedings of the Hawaiian Entomological Society* **8**: 153–162.
- 1941. Encyrtidae of the Marquesas and Society Islands (Hymenoptera, Chalcidoidea). *Occasional Papers of the Bernice Pauahi Bishop Museum* **16**: 215–230.
- Trjapitzin, V. A.** 1962a. Materials on the encyrtid fauna (Hymenoptera, Encyrtidae) of the Caucasus. I. [In Russian.] *Entomologicheskoe Obozrenie* **41**: 426–435. [English translation: *Entomological Review, Washington* **41**: 260–265.]
- 1962b. Encyrtidae (Hymenoptera) – parasites of *Nipponaclerda turanica* (Arch.) (Homoptera, Aclerdidae) in Nogai steppe. [In Russian.] *Zoologicheskii Zhurnal* **41**: 560–570.
- 1963. On the systematic position of *Coccidencyrtus ambiguus* (Nees) (Hymenoptera, Encyrtidae). [In Russian.] *Entomologicheskoe Obozrenie* **42**: 884–888. [English translation: *Entomological Review, Washington* **42**: 479–481.]
- 1964a. Encyrtidae (Hym.) – parasites of Dryinidae (Hym.) in USSR. [In Russian.] *Zoologicheskii Zhurnal* **43**: 142–145.
- 1964b. New encyrtids (Hymenoptera, Encyrtidae) from steppes and deserts of Kazakhstan. [In Russian.] *Trudy Zoologicheskogo Instituta Akademii Nauk SSSR* **34**: 235–246.
- 1965. Contribution to the knowledge of the encyrtid fauna of the Comodo and Padar Islands with a catalogue of Indonesian species (Hymenoptera, Encyrtidae). *Treubia* **26**: 309–327.
- 1968. A review of the encyrtids (Hymenoptera, Encyrtidae) of the Caucasus. [In Russian.] *Trudy Vsesoyuznogo Entomologicheskogo Obshchestva* **52**: 43–125.
- 1969a. Redescription of the types of *Charitopus andalusicus* Mercet and *Xanthoectroma aquilinum* Mercet (Hymenoptera: Encyrtidae). *Beiträge zur Entomologie* **19**: 673–677.
- 1969b. A Palaeartic representative of the genus *Parahomalopoda* (Hym., Encyrtidae). [In Russian.] *Zoologicheskii Zhurnal* **48**: 1252–1254.
- 1971a. Review of the genera of Palaeartic encyrtids (Hymenoptera, Encyrtidae). [In Russian.] *Trudy Vsesoyuznogo Entomologicheskogo Obshchestva* **54**: 68–155.
- 1971b. Encyrtidae (Hymenoptera, Chalcidoidea) collected by E. S. Sugonjaev in Afghanistan. I. *Entomological Essays to Commemorate the Retirement of Professor Yasumatsu* pp. 119–127. Tokyo.
- 1972. Host-parasite relations in the family Encyrtidae (Hymenoptera, Chalcidoidea). [In Russian.] *In* Zaslavsky, V. A. (Ed.), *Host-parasite relations in insects* pp. 31–48. Leningrad.
- 1973a. The classification of the parasitic Hymenoptera of the family Encyrtidae (Hymenoptera, Chalcidoidea). Part I. Survey of the systems of classification. The subfamily Tetracneminae Howard, 1892. [In Russian.] *Entomologicheskoe Obozrenie* **52**: 163–175. [English translation: *Entomological Review, Washington* **52**: 118–125.]
- 1973b. Classification of the parasitic Hymenoptera of the family Encyrtidae (Chalcidoidea). Part II. Subfamily Encyrtinae Walker, 1837. [In Russian.] *Entomologicheskoe Obozrenie* **52**: 416–429. [English translation: *Entomological Review, Washington* **52**: 287–295.]
- 1977. New genera and species of parasitic Hymenoptera of the family Encyrtidae (Hymenoptera: Chalcidoidea). *Folia Entomologica Hungarica* **30**: 153–166.
- 1978. Hymenoptera II. Chalcidoidea 7. Encyrtidae. [In Russian.] *Opredelitel' Nasekomykh Evropejskoy Chasti SSSR* **3**: 236–328.
- 1981. Key to Palaeartic species of the genus *Psyllaephagus* (Hym.: Encyrtidae). *Entomophaga* **26**: 395–399.
- 1982a. Two new encyrtid genera (Hymenoptera, Encyrtidae) from the Turkmenian fauna. [In Russian.] *Izvestiya Akademii Nauk Turkmenskoy SSR* **1982** (2): 38–40.
- 1982b. Two new species of the genus *Helmecephala* (Hymenoptera, Encyrtidae) from Costa Rica and Indonesia. [In Russian.] *Zoologicheskii Zhurnal* **61**: 1602–1604.
- Trjapitzin, V. A. & Gordh, G.** 1978a. Review of genera of Nearctic Encyrtidae (Hymenoptera, Chalcidoidea). I. [In Russian.] *Entomologicheskoe Obozrenie* **57**: 364–385. [English translation: *Entomological Review, Washington* **57**: 257–270.]
- — 1978b. Review of genera of Nearctic Encyrtidae (Hymenoptera, Chalcidoidea). II. [In Russian.] *Entomologicheskoe Obozrenie* **57**: 636–652. [English translation: *Entomological Review, Washington* **57**: 437–448.]
- — 1979. Revision of the genus *Hemaenasius* (Hymenoptera, Chalcidoidea, Encyrtidae). [In Russian.] *Zoologicheskii Zhurnal* **58**: 855–859.
- — 1980a. Encyrtids of the genus *Tetracnemoidea* Howard, 1898 (Hymenoptera, Encyrtidae). [In Russian.] *Entomologicheskoe Obozrenie* **59**: 169–175. [English translation: *Entomological Review, Washington* **59**: 129–140.]

- — 1980b. Redescription of *Epiencyrtus* (Hymenoptera: Encyrtidae). [In Russian.] *Zoologicheskii Zhurnal* **59**: 463–466.
- Trjapitzin, V. A. & Khlopunov, E. N.** 1976. New Encyrtidae (Hymenoptera) – parasites of Coccoidea (Homoptera) from Vietnam. [In Russian.] *Trudy Zoologicheskogo Instituta Akademii Nauk SSSR* **64**: 98–103.
- Trjapitzin, V. A., Myartseva, S. N. & Kostyukov, V. V.** 1977. A new species of parasitic *Oencyrtus* Ashmead, 1900 (Hym., Encyrtidae, Chalcidoidea) from Vietnam. [In Russian.] *Entomologicheskoe Obozrenie* **56**: 670–675. [English translation: *Entomological Review, Washington* **56**(3): 130–133.]
- Viggiani, G.** 1966. Ricerche sugli Hymenoptera Chalcidoidea. VI. Generi e specie nuovi per l'entomofauna italiana (Encyrtidae, Aphelinidae, Mymarommidae). *Bollettino del Laboratorio de Entomologia Agraria 'Filippo Silvestri'* **24**: 84–105.
- 1967. Ricerche Sugli Hymenoptera Chalcidoidea. 13. Sugli entomoparassiti della *Semidalis aleurodi-formis* Steph. (Neur. Coniopterygidae), con descrizione di un nuovo genere di Encyrtidae (Prima nota). *Bollettino del Laboratorio de Entomologia Agraria 'Filippo Silvestri'* **25**: 163–176.
- 1970. Note su alcuni Cheiloneurini, con considerazioni sui generi *Cheiloneurus* Westw., *Neoprochiloneurus* Vigg. e *Prochiloneurus* Silv. (Encyrtidae). (XIX. Ricerche sugli Hymenoptera Chalcidoidea.) *Bollettino della Società Entomologica Italiana* **102**: 64–69.
- Walker, F.** 1837. Monographia Chalciditum. *Entomologist's Magazine* **4**: 349–364, 439–461.
- 1838a. Monographia Chalciditum. *Entomologist's Magazine* **5**: 35–55, 102–118, 418–431, 518.
- 1838b. Descriptions of some Chalcidites discovered by C. Darwin, *Entomologist's Magazine* **5**: 469–477.
- 1839. *Monographia Chalciditum*. 2, 100 p. London.
- 1842. (Explanation of plates A-P.) *Entomologist* **1**: v-vi.
- 1846. Characters of some undescribed species of Chalcidites. *Annals and Magazine of Natural History* (1) **17**: 108–115, 177–185, 270–272.
- 1848. *List of the specimens of hymenopterous insects in the collection of the British Museum*, pt 2, Chalcidites, additional species. iv, 237 pp. London.
- Waterston, J.** 1915. *Ooencyrtus pacificus* a new egg parasite from Fiji. *Bulletin of Entomological Research* **6**: 307–310.
- 1928a. A new encyrtid (Hym., Chalcid.) bred from *Clastoptera* (Hom., Cercop.). *Bulletin of Entomological Research* **19**: 249–251.
- 1928b. On an encyrtid (*Leefmansia bicolor* gen. et sp. n.) reared from eggs of *Sexava* (Orth.) in the Dutch East Indies. *Annals and Magazine of Natural History* (10) **1**: 527–529.
- Westwood, J. O.** 1832. Descriptions of several new British forms amongst the parasitic hymenopterous insects. *Philosophical Magazine* (3) **1**: 127–129.
- 1833a. Descriptions of several new British forms amongst the parasitic hymenopterous insects. *Philosophical Magazine* (3) **3**: 342–344.
- 1833b. Notice of the habits of a cynipideous insect, parasitic upon the rose louse (*Aphis rosae*): with descriptions of several other parasitic Hymenoptera. *Magazine of Natural History and Journal of Zoology, Botany, Mineralogy, Geology and Meteorology* **6**: 491–497.
- 1837. Description of a new genus of British parasitic hymenopterous insect. *Annals and Magazine of Natural History* (N.S.) **1**: 257–259.
- 1838–1840. Synopsis of the genera of British insects. In: *An introduction to the modern classification of insects*. 2 (appendix) 158 pp. London.
- Williams, L. T.** 1916. Notes on the egg-parasites of the apple-tree tent caterpillar (*Malacosoma americana*). *Psyche* **23**: 149–153.
- Yasumatsu, K. & Yoshimura, S.** 1945. Some chalcidoid parasites of *Saissetia nigra* and *S. hemispherica* in Micronesia. *Mushi* **16**: 29–34.

Index

Invalid names are in *italics*, principal page references are in **bold**

- abilis 246, 360
 abjectus 338
 Ablerus 274
 abnormis (*Leptomastidea*) 293
 abnormis (*Parectromoidella*) 319, 320, 363
 abnormiscapus 317
 abyssus 330, 365
 acacallis 268
 acaciae 319
 acanthococci 317
 Acerophagoides 295
 Acerophagus 144, 146, **220**, 289, 300, 328, 329, 354, 356, 363
 Achalcerinys 219, **220**, 350, 353, 357, 359
Achrysophagus 327, 363
 aciculatus 229
Acridencyrtus 259, 357, 361
 acutigastri 330
 acutiventris 350
 adamsoni 229
 Adekhitopus 166, 170, 176, 180, 184, **221**, 354
 Adelencyrtoides 216, 219, **223**, 353, 356
 Adelencyrtus 162, 166, 176, 192, 196, 212, 216, 219, **223**, 224, 255, 273, 274, 353, 356, 359
 adustipennis 352
 advena Beardsley 280
 advena Compere 225
 aegyptiacus 327
 Aenasiella 154, 158, 168, 215, **224**, 331, 341, 353, 356, 359, 364, 365
 Aenasioidea 162, **225**, 237, 298, 354, 355, 356, 359, 362
 Aenasius 154, 215, **225**, 227, 242, 277, 297, 306, 355, 356
 aeneifrons 322, 363
 Aenasomyiella 164, **226**, 298, 354, 355, 357, 359, 362
 aeneoculex 330, 363
 aereifemur 294, 362
 aereiscutellum 333, 364
 aereitibiae 272, 361
 aereipes 257, 361
 aeruginosus 339
aestivalis 258
 Aethognathus 308
 africana Compere 346
 africanus Gahan 339, 364
 africanus Girault 315
 Agarwalencyrtus 176, 204, 218, **226**, 353, 356, 357
 agarwali Hayat 327
 agarwali Hayat & Subba Rao 298
 Ageniaspis 166, **226**, 227, 275, 276, 287, 341, 352, 354, 356, 357, 359
 agracensis 229
 ajanea 294, 365
 Alamella 158, 162, 170, 182, **227**, 354, 356
 alami 229
 alberti 298
 albiclava (*Cryptanusia*) 262
 albiclava (*Hexencyrtus*) 286, 359
albiclava (*Psyllaephagus*) 330, 363
 albiclavata Ashmead 280, 362
 albiclavatus Agarwal 287
 albiclavatus Ashmead see albiclavata
 albiclavatus Shafee et al. 319
albicoxa 249, 250, 358
 albidus 269
albifemur 314, 359
 albiflagellum 253, 360
 albifunicle 241
 albifuniculus (*Cheiloneurus*) 249
 albifuniculus (*Prochiloneurus*) 327
 albioviductus (*Australaphycus*) 237
 albioviductus (*Prochiloneurus*) 327, 363
 albisetosa see albisetosus
 albisetosus 296, 362
 albitarsis 253, 360
 albitibiae 235
 alboantennata see alboantennatus
 alboantennatus 309, 362
 albobilosus 330
 aldrichi 322
aliena Timberlake 254
 alienus Riek 330
 aligarhensis Agarwal 229
 aligarhensis Hayat 180, 297
 aligarhensis Hayat et al. (*Anicetus*) 231
 aligarhensis Hayat et al. (*Trechmites*) 345
 aligarhensis Khan & Shafee 293
 aligarhensis Shafee et al. (*Diaphorencyrtus*) 263
 aligarhensis Shafee et al. (*Psyllaephagus*) 330
 aligerhini 225, 359
 Allencyrtus 347
Allorhopoideus 269
 almoriensis 229
 Aloencyrtus 347
 altensteinii 243
 amathus 343
Amaurilyma 314, 358
 ambigua 172, 292, 362
 ambiguous 174, 259, 361
 ambiguous see ambigua
 Ameniscocephalus 176, **227**, 355
americanus 249
 Amicencyrtus 184, 210, **227**, 260, 354
Aminellus 259, 260, 357, 361
 Amira 210, 215, **228**, 285, 353, 355, 359
 amoenus 229
 amplis 341, 365
 amurensis 247, 360
Anabrolepis 224, 273, 358, 359, 362
 Anagyritetta 157, 160, 184, **228**, 354, 356
 Anagyrodes 210, **228**, 245, 276, 277, 301, 306, 308, 316, 326, 354, 355, 359, 365
Anagyropsis 330, 331, 350, 358, 363, 364, 365
 Anagyrus 158, 162, 164, 172, 174, 180, 184, 186, 206, **229**, 230, 256, 261, 266, 267, 272, 278, 280, 281, 330, 331, 344, 352, 354, 356, 359, 361, 362, 363, 361, 362, 363, 364, 365
 anamalainus 272, 361
 ananaitis 229
 Ananusia 200, 206, 217, **231**, 355, 356, 357, 359
Anaphycus 298
 Anarhopus 143, **231**, 354, 356, 358
 Anastatus 299
 Anathrix 317
Angeliconana 257, 258, 357, 359
 angeliconini 290, 362
 angelicus 328
 angustifrons Compere 298
 angustifrons Shafee et al. 304, 362
 angustus 231
 Anicetus 150, 152, **231**, 265, 315, 353, 355
Anisodromus 303, 358, 362
 Anisophleps 292
Anisotylus 287, 288, 358
 anna 330, 363
 annulatus Ferrière 327, 363
 annulatus Timberlake 231
 annulicornis 238
 annulipes 253
 Anomalencyrtus 170, 182, **232**, 354
 Anomalicornia 146, 148, 170, 182, 232, 354, 356
 anomalococci 299
 antennata 300
 Anthemus 143, 145, **233**, 354, 356
Antipodencyrtus 342, 358, 365
 antoninae 158, 186, 229
 Anusia 265, 347, 361, 365
Anusiella 342
Anusoidea 262
Anusomyia 333, 358, 364
Apentelicus 299
Aphidencyrtus 263, 309, 338, 339, 341, 358, 361, 363, 364, 365
 aphidiphagus 338
 aphidivorus 339, 364
Aphycaspis 234
 aphycoides 314, 315, 363, 366

- Aphycoideus* 234
Aphycomorpha 186, 208, **233**,
 234, 300, 353, 356
Aphycopsis 200, **233**, 298, 353, 362
Aphycus 174, 186, 198, 202, 225,
 233, **234**, 255, 273, 280, 288, 289,
 298, 328, 329, 354, 356, 359,
 360, 362, 363, 365
apicalis 234
apicatus 248
apicicornis 283, 362
apiomorphae 224
Apoanagyrus 272, 273, 358, 361
Apoleptomastix 170, 180, 235,
 293, 354, 356
Aprionomastix 362
Apterencyrtus 349
apterus 332
apus 246, 358
aquacyaneus 339, 364
aquilonaris 190, 260, 261
aquilus 330
Arachnosinus 328
Araticus 246, 247, 357, 360
Aratus 246, 247, 339, 357, 365
araucariae 186, 233
arboris 246, 358
arctatus 330, 365
arduus 330
areolata 361
arenicola 259, 361
Arescon 233
argenteus 298, 362
argenticoxa 269, 361
argentinotata 267
argentipes Girault 272, 361
argentipes Howard 349
argentiscapus 269, 359
argutus 330, 365
Arhopoideus 231, 342, 358, 359
aristotelea 299
armatus 343
Arrenoclavus 257
Arrhenophagoidea 143, 145, **235**,
 354, 356
Arrhenophagus 143, 145, **235**,
 354, 356
arsanes 330, 331, 363, 365
articulus 273, 274, 362
ascitus 330
Aseirba 186, **235**, 236, 238, 284,
 320, 354
ashmeadi Girault (*Cerchysiella*)
 246, 358
ashmeadi Girault (*Mesanusia*)
 296, 362
ashmeadi Hayat et al. 232
Asitus 162, 168, 186, **236**, 283,
 354, 356
asperithorax 255, 360
aspidioti 233
aspidiotiphaga 256
asser 330, 365
Asteropaeus 231
Astymachus 176, 186, 206, **236**,
 354, 355, 356
atavus 330, 365
Athesmus 343
atoma 302
atratus 330, 365
atriphragma 298, 362
Atropates 292
attenuatus 330
aulacaspidis 224
Aulonops 288, 289, 358, 362
aurantiaca 170, 292
aurantifasciata 269, 359
auraticorpus (*Leptomastix*) 293
auraticorpus (*Neastymachus*) 160,
 304
auraticutum (*Epidinocarsis*)
 272
auraticutum (*Rhytidothorax*)
 333, 364
aureipleurum 327, 363
aureiscutellum 262
aureus 307, 359
auricaput 350, 365
auricornis 253, 360
auricorpus (*Pseudectroma*) 329
auricorpus (*Psyllaephagus*) 330,
 363
Australanusia 166, 218, **236**, 353
Australaphycus 184, **237**, 354
Australencyrtus 340
australia (*Aenasiella*) 224
australia (*Callipteroma*) 244, 358
australia (*Cerapterocerus*) 245
australia (*Copidosoma*) 257
Australia 172, 186, **237**, 315, 353
australiae 249
australicum 257
australicus Girault 307, 359
australicus Prinsloo 299
australiensis Ashmead 174, 247,
 352
australiensis Girault (*Ooencyrtus*)
 309, 362
australiensis Girault
 (*Paraenasomyia*) 316, 363
australiensis Girault
 (*Psyllaephagus*) 330, 363
australiensis Girault, 1914
 (*Tachinaephagus*) 340, 359, 365
australiensis Girault, 1915
 (*Tachinaephagus*) 340, 359
australiensis Girault, 1917
 (*Tachinaephagus*) 340
australiensis Girault
 (*Tetracnemus*) 342
australiensis Girault (*Trechnites*)
 345
australiensis Howard (*Anagyrus*)
 229
australiensis Howard
 (*Aphycopsis*) 233, 365
australiensis Howard
 (*Tetracnemoidea*) 341, 342
australis Girault, 1914
 (*Cerchysius*) 247, 360
australis Girault, 1915
 (*Cerchysius*) 247
australis Girault (*Coccidencyrtus*)
 253, 360
australis Girault (*Copidosoma*)
 257
australis Trjapitzin & Gordh 231,
 359
Australomolatylys 340
Australrhopoideus 329, 358, 363
Australzaomma 288, 358, 362
austrina 332
Austrochorea 146, 148, **237**, 357,
 359
Austroencyrtoidea 213, **238**, 353
Austroencyrtus 133, 186, 236, **238**,
 284, 320, 349, 354, 356, 360
Austromira 180, **238**, 353
Austrotropidia 246, 357
Avetianella 160, 164, 186, **239**,
 353, 356
avus 330
axillaris Girault (*Adelencyrtus*)
 224
axillaris Girault (*Zarhopaloides*)
 349, 350
axillaris Hayat et al. 249
axillaris Timberlake 174
babindae 255, 359
Bacalusa 170, 176, 182, 186, 188,
239, 354, 360
bacchae 338
Bachiana 200, **241**, 254, 353, 356
Baeoanusia 168, 216, 219, **241**,
 249, 250, 304, 353, 356, 360, 362
baethi 229
baezi 269
bakeri Ashmead 342
bakeri Howard 257
bambeyi 281
bangalorensis Shafee et al. 325
bangalorensis Subba Rao 249
basileus 330, 365
basiri 249
batocerae 172, 309
Batrachencyrtus 255
Bavanusia see *Baeoanusia*
beenleighi 271
beerwahi 249, 360
Beethovenia 144, **241**, 354
beethoveni 300
bellator 229
bellulus 316
bellus 229, 359
beneficus Ishii & Yasumatsu 232
beneficus Shafee 166, 194, 269,
270, 271, 361
Bennettisca 347
Berecynciscus 257
Berecyncytus 257
bermudensis 273, 361
Bethylomimus 349
bhimolporinae 259, 361
bicinctipes 162, 273, 274, 359
bicinctitibiae 298, 362
bicolor Girault (*Charitopus*) 248,
 360

- bicolor Girault (Coccidencyrtus) 172, 253, 360
 bicolor Girault (Ooencyrtus) 309, 310
 bicolor Girault (Tetracnemoidea) 342, 359, 365
 bicolor Waterston 292
 bicoloricornis (Apoleptomastix) 235
 bicoloricornis (Paralitomastix) 316, 363
 bicoloripes 145
 bicristatus 265
bidentimaxillae 250, 358
 bifasciata Brèthes 229
 bifasciata Girault 271
 bifasciata Howard 256
 bifasciata Timberlake see bifasciatus
 bifasciatella 342
 bifasciatus Girault see bifasciata
 bifasciatus Ishii 224
 bifasciatus Timberlake 178, 288, 289, 362
 bififormis 326
 bimaculatus 224
 binotativentris 248
 bioculata (Borrowella) 242, 358
 bioculatus (Neabrolepoideus) 303
 blandus 330
 Blastothrix 168, 213, 241, **242**, 330, 331, 354, 355, 356, 360, 364
Blatticida Ashmead 249
Blatticida Girault 296, 358, 362
Blatticidella Gahan & Fagan 296, 358
Blatticidella Girault 272, 357, 361
 Blepypus 215, 225, **242**, 355, 356
 bliteus 330, 365
 bohemicus 259, 361
 boletus 330
 bolivari 327
 bolus 330, 365
 Borrowella 198, 214, **242**, 268, 354, 358
 bosqi 287
 Bothriophryne 184, **243**, 353, 355
 Bothriothorax 210, **243**, 247, 268, 276, 286, 354, 357, 360
 bouceki 182, 190, 251, **252**
 boucheanum 257
 bowensis 298, 362
 brachiatus 330, 365
 Brachyplatycerus 143, **243**, 354
 brachyptera Mercet 332
 brachypterus Dodd 348
 brachyscelidus 154, 224, 225
Bregmencyrtus 228
 brevicaudatus 315
 brevicollis 342
 brevicornis Dalman 314, 315, 363
 brevicornis Girault (Psyllaephagus) 330, 363
 brevicornis Girault (Tetracnemoidea) 342
 brevipediculus 293
 brevis 293
 breviventris 318, 319
 bridwelli 332
 britannica 242
 brittanica 349
 broccus 330
 brouni 342
 bruchus 330
 brunnea see brunneus
 brunneipes 288
 brunneus 288, 362
 bryanti 220, 289, 329
 bucculatricis (Copidosoma) 257, 361
 bucculatricis (Ooencyrtus) 310, 363
 bucculentus 286, 362
 buderimi 298, 362
 burksi 304, 362
 burnsi (Cheiloneurus) 249, 360
 burnsi (Psyllaephagus) 162, 330, 363
 Caenohomalopoda 143, **243**, 244, 353, 356
 caerulea 295, 296
 caeruleus see caerulea
 calidii 255
 californica Timberlake 278
 californicus Compere 158, 272
Calliencyrtus 286, 358, 362
 Callipteroma 174, **244**, 335, 354, 356, 357, 358
Calluniphilus 330
 calocense 342
Calocerinella 244
Calocerineloides 330, 331, 358, 364
 Calometopia 314
 capitatus 303
 capnodiobia 239
 Carabunia 164, 172, **244**, 245, 354, 355, 357, 360
 carinatus 330
 Casca 274
 cassatus 339, 364
 casuarinae 166, 178, 208, 336, **337**, 364, 365
 caudata Cameron 235, 236
 caudatus Girault (Epiblatticida) 272, 361
 caudatus Girault (Nezarhopalus) 254, 307
 cellinini 330, 363
centaurus 249, 250, 358
 centennalis 247, 360
cerapterocera 256
 Cerapteroceroides 150, 188, **245**, 347, 353, 355, 356, 357
 Cerapterocerus 146, 148, 152, 188, **245**, 292, 347, 353, 355, 357
 Ceraptrocerella 152, 154, **246**, 355, 356, 357, 358
 Cerchysiella 162, 170, 192, 213, 215, 218, **246**, 247, 257, 278, 280, 322, 349, 353, 354, 356, 357, 358, 360
Cerchysiopsis 254, 339, 357, 360, 365
 Cerchysius 172, 174, 184, 196, 238, **247**, 254, 316, 339, 340, 352, 353, 356, 360, 365
 Cercobelus 134, 143, 145, 188, **247**, 354, 355
 cerococi (Metaphycus) 298
 cerococci (Neastymachus) 304, 362
 ceroplastae 243
 ceroplastis 280
 ceroplastodis 231
 cervantesi (Diversinervus) 265
 cervantesi (Fulgoridicida) 278
 cervincinta 226
 ceylonensis 231, 232
 ceylonicus 340
 Chalcaspis 225
Chalcerinys 283, 358, 362
 chalconotus 257
 channingi 162, 330, 363
 Charitopus 139, 180, **248**, 270, 305, 354, 357, 358, 360
 Cheiloneurella 166, 169, 178, 188, 190, 206, **248**, 353
Cheiloneuroides 265
 Cheiloneuromyia 202, **249**, 353, 355, 360
 Cheiloneurus 148, 150, 156, 196, 202, 215, 216, 238, **249**, 250, 267, 268; 297, 299, 303, 304, 326, 327, 343, 353, 355, 356, 357, 358, 360, 363, 365
Cheilonicetus 291
 cheles 249, 250, 360, 365
Chestomorpha 326
Chiloneurinus 349
Chinchilla 237, 357, 359
Chinchillisca 237, 357
 chinensis 232
 chionaspidis Aurivillius 235
 chionaspidis Erdős 343
 chionaspidis Howard (Adelencyrtus) 223, 224
 chionaspidis Howard (Anthemus) 233
 chlorodryini 249, 358
 Chrysis 268
 chrysopae 249
 Chrysopaltycerus 152, 246, **250**, 355, 356
Chrysopophagoides 249, 250, 357, 360
Chrysopophagus 249, 250, 358, 360
 chrysos 274
 cicada 330, 359, 363
 ciliatus 236
cinctifemur 254, 358
 cinctipes 339, 364
 cinctithorax 256, 350, 365
 cinctiventris (Cheiloneurus) 249, 250, 360, 363
 cinctiventris (Copidosomyia) 259
 cinctiventris (Protyndarichoides) 328

- cinctorum 330, 364
 Cirrhencyrtus 234, 273
 citri (Agarwalencyrtus) 176, 226
 citri (Anagyrus) 229
 citricola Annecke & Mynhardt 298
 citricola Loginovskaya 226
 citriculus 250
 citrina 280
 Cladiscodes 180, 215, **251**, 355, 356
 claripennis 341, 365
 clarus 330, 365
 clauseni 299
 Clausenia 180, **251**, 320, 354, 356
 clavatus Eady 160, 347
 clavatus Girault 327
 clavatus Hayat et al. 224
 clavicornis 176, 319
 claviger Mercet 257
 claviger Timberlake 298
 clavus 225
 clisiocampae 309
 Coagerus 182, 190, 216, **251**, 354
 Coccidaphycus 144, 148, **253**, 345, 353, 355
Coccidencyrtoides 253
 Coccidencyrtus 143, 162, 168, 172, 192, 219, 224, 225, 226, **253**, 254, 258, 274, 305, 316, 317, 321, 325, 339, 353, 356, 357, 359, 360, 361, 363, 365
 coccidiphagus 234
 Coccidoctonus 162, 168, 186, 198, 241, **254**, 263, 272, 307, 332, 339, 341, 353, 355, 356, 357, 358, 360
 coccidoxenoides 237, 315
 Coccidoxenoides 182, 218, **255**, 295, 330, 354, 356, 357, 359, 360
Coccidoxenus 224, 253, 309, 331, 339, 346, 359, 360, 363, 364, 365
 coccois 220
 Coccophagus 353
 Coccophoctonus 242
 cochereaui 309
 Coelaspida 146, **255**, 355, 356
 Coelopencyrtus 160, 162, 164, 172, 182, 190, 217, 218, **255**, 256, 278, 350, 352, 354, 357, 360, 361
 coeruleus 299
 coleridgei 226
 coloripes 235
 columbi 277, 362
 comara 166, 176, 294, 362
 communis 232
 compactus 330, 364
 comperei Subba Rao & Rai 229
 comperei Timberlake 262
 comperei Viggiani 327
Comperencyrtus 342
 Comperia 156, **256**, 353, 355
 Comperiella 150, 190, **256**, 278, 280, 338, 353, 356, 362
 compressicornis 249
 compressifemur 268, 361
 compressipes 162, 305, 359
 compressiventris 257
 Comys 268
 Conchynilla 178, **256**, 257, 353
 concisus 330
 concolor 184, 194, 196, 281, **282**
 concupiens 283
 confusus 322, 363
 consobrina 242, 358
 convexus Girault (Parablatticida) 314, 359, 365
 convexus Girault (Parechthrodryinus) 319
 convexus Noyes (Parablatticida) 314, 365
 cooki 229, 359
 Copidosoma 164, 166, 172, 174, 176, 178, 182, 184, 186, 192, 204, 210, 213, 216, 217, 218, 220, 247, **257**, 258, 316, 317, 330, 334, 354, 356, 357, 359, 360, 361, 363, 365
 Copidosomopsis 144, 146, **258**, 259, 332, 354, 356, 357, 361
 Copidosomyia 174, 198, **259**, 354, 355, 357, 361
 corbetti 309
 corniger see cornigerum
 cornigerum 150, 277
 cornuatus 330
 cornuphagus 330, 365
 corvinus 269
Cowperella 322, 358, 363
 Cowperia 172, 196, 208, 228, **259**, 319, 354, 356, 357, 361, 365
 coxalis 224
 crassa see crassus
 crassicornis 255, 256, 360
 crassulus 309
 crassus 305, 362
 Cremesina 146, 148, 157, 158, 190, 192, **260**, 354
 creona 309
 cristata see cristatus
 cristata (Homalopoda) 287
 cristatus (Cheiloneurus) 249, 360
Cristatothorax 249, 250, 358, 360
 crotolariae 298
 crucifer 338
 Cryptanusia 152, **262**, 271, 320, 347, 354, 356, 361
 cuneinota 272
 cupreicollis 249
 cuprifrons 248
 curiosa 241
 cyaneus 346
 Cyrtocoryphes 164, 174, 192, 262, **263**, 320, 347, 354
 daccaensis 257, 361
 dactylopii Ashmead 242
 dactylopii Howard (Anagyrus) 186, 229
 dactylopii Howard (Leptomastix) 170, 293
 dahmsi 169, 172, 194, 275, **276**
 dalmani 281
 darevskii 229, 359
 daulai 150, 291, 292
 deccanensis 342
 dei 229, 359
 delhiensis 304, 362
 deltoideus 232
 delitescens 325
 depressus 224
 desantisi 257
 desantisiellus 332
Desobius 314, 358
 destructor 309, 310, 363
 dewitzi 160, 274
 Diaphorencyrtus 190, 212, 219, **263**, 353, 355, 361
 diaphorinae Hayat 332
 diaphorinae Lin & Tao 263, 361
 diaphorinae Myartseva & Trjapitzin 263, 361
 diaphorinae Shafee et al. 263
 diaspidis 325
 Diasula 169, 192, 196, **263**, 264, 265, 361, 365
 Dicarnosis 256
Dicelloceras 299
 dichroma 278
 dignus 330, 365
 dilatata 244, 245, 360
 dimorpha 283
 Dinocarsis 229, 230, 272, 317, 319, 320, 325, 359, 361, 363
 discretus 330, 365
 ditaeniatus 299
 dius 330, 364
 diversicolor 249
Diversicornia 248
 diversicornis Howard 273, 361
 diversicornis Mercet 229
 diversicornis Westwood 342
 Diversinervus 148, 150, **265**, 292, 353, 355
 divina see divinus
 divinus 326, 363
 Doddanusia 154, 156, 192, **265**, 266, 353, 361
 dodonia 232
 Doliphoceras 134, 158, 162, 164, 170, 172, 182, 229, 230, 240, **266**, 267, 354, 356, 359, 360, 361
 dorceto 325
 dubia see dubius
dubia (Psyllaephagus) 330, 359
dubius (Cheiloneurus) 249, 358
 dubius (Coccidoctonus) 254, 358, 360
 ductor 318
 dumasi 249
 dunense 268
 durantae 228
 Dusmetia 306
 dyari 154, 330, 364
 Echthrobacella 176, **267**, 353
Echthrobaccha 290, 338, 339, 362, 365
Echthrobacomyia 220, 357, 359

- Echthrodryinus* 309, 310, 358, 363
Echthrogonatopus 172, 178, 196, 213, 215, 219, **267**, 288, 294, 328, 353, 355, 357, 362, 363
 echthromorpha 174, 295
Echthroplexiella 234
Echthroplexis 254, 360
Ectopiognatha 162, 166, 192, **267**, 353, 355
Ectroma 148, **268**, 290, 353
Ectromella 342, 358, 365
Ectromoides 333, 358, 364
Ectromomyiella 273, 274, 358, 362
eja 257, 258, 359
elegans Dalman 249
elegans Silvestri 265
elgeri Kerrich 273, 361
Elijahia 244, 357, 360
emarginatus 330, 365
emersoni (Anthemus) 233
emersoni (Cerapterocerus) 245
emersoni (Eucomomorphella) 276
emersoni (Mesorhopella) 297
emersoni (Psyllaephagus) 330, 364
emersoni 273, 359
Encyrtoidea 178, 192, 214, 216, 218, 224, **268**, 354, 359, 361
Encyrtolophus 250
Encyrtomyia 253, 254, 345, 357, 360, 365
Encyrtus 150, 200, 223, 224, 225, 226, 229, 234, 242, 247, 249, 250, 253, 257, 258, **268**, 269, 273, 276, 277, 281, 287, 292, 294, 299, 301, 305, 308, 309, 314, 316, 317, 320, 325, 330, 331, 332, 338, 339, 346, 349, 352, 353, 354, 355, 359, 360, 361, 362, 363, 364, 365
ensifer 253
Eotopus 166, 180, 194, **269**, 270, 354, 356, 361
Epaenasomyia Girault, 1917 322, 358
Epaenasomyia Girault, 1919 255, 256, 357, 361, 363
Epanagyrs 330, 331, 358, 364
Epanusia 150, 262, **271**, 320, 354, 363
Epiblatticida 168, 198, 254, **272**, 339, 347, 353, 355, 357, 361, 365
Epicheiloneurus 249, 250, 357, 358, 360
Epidinocarsis 158, 164, 172, 229, 230, **272**, 273, 354, 356, 358, 359, 361
Epiencyrtoides 224, 359
Epistenoterys 198, 202, **273**, 354, 356, 358, 361
Epitetracnemus 154, 158, 216, 224, 253, 272, **273**, 353, 356, 358, 359, 360, 361, 362
Epitetrалophidea 162, 168, 219, 224, **273**, 274, 353, 358, 359, 362
Erencyrtus 160, 164, 204, **274**, 353, 356, 362
Ericydnella 246, 357
Ericydnus 170, 269, 271, **274**, 354, 356, 361
 eriococci 349
 erionotae 309
Ethoris 169, 172, 190, 194, **275**, 276, 354
Euaphycus 234
 eucalypti 224, 225, 359
Euchalerinys 283, 358, 362
Eucheiloneuropis 319, 320, 363
Eucomomorphella 214, **276**, 301, 354
Eucomys 228, 268, 269, 359, 361
Eugahania 157, 158, 229, **276**, 354, 355
Eupelmomorpha 248, 357, 358, 360
 europaea Mercet 329, 363
 europaeus Girault 332
 europaeus Mercet see europaea
Euryhopalus 217, 225, **277**, 355, 356
Euryscapus 299
Eusemion 150, 152, **277**, 353, 355
Eusemionella 249, 250, 326, 357, 360, 363
Eusemionopsis 249, 250, 357, 358
Euussuria 343
 euxoae 309, 363
Euzkadia 299
 excisus 330, 365
 exiguus 330, 366
 eximia see eximius
 eximius (Helegonatopus) 283, 362
 eximius (Meniscocephalus) 296
 exitiosus 178, 267
 exiflores 296, 362
Exoristobia 168, 180, 194, 213, 220, **277**, 315, 323, 353, 357, 358, 362, 365, 366
 extraclavus 332
 extranea see extraneus
 extraneus 273, 362
 fabrei 228
 facetus 330, 366
 facilis 330, 366
 fasciata see fasciatum
 fasciatipennis 326
 fasciatipes 304
 fasciatum 257, 361
 fasciiscapus 229, 359
 faustus 330, 366
 felix 231, 232
 fera Girault (Kakaoburra) 289, 290
 fera Girault see ferus
 feralis 339, 364
 ferrierei Hayat et al. 287
 ferrierei Shafee et al. 309
Ferriereus 236
 ferrisi 250
 ferus Girault (Rhytidothorax) 333, 364
 ferus **nom. nov.** 229, 365
 fijiensis 154, 178, 200, 310, **311**
 flabellata see flabellatus
 flabellatus 330
 flaccus 249
 flaminius 139, 287, 288
flandersi 246, 358
 flava Agarwal 158, 170, 227
 flava Girault 347, 365
 flava Shafee see flavus
 flava Shafee et al. 280
 flaviceps 229
 flavicollis 250
 flavidulus 328
 flavidus 229
 flavimesopleurum 229, 359
 flavipes Mercet 148
 flavipes Timberlake (Hypergonatopus) 288
 flavipes Timberlake (Ooencyrtus) 309, 363
 flaviscutellum 326
 flavithorax 338, 339, 359, 364
 flavovarius 318
 flavus Howard (Metaphycus) 298
 flavus Howard (Microterys) 299
 flavus Ishii 365
 flavus Shafee 229, 230, 365
 floridanus 257
 foersteri 229, 359
 Forcipestricis 282
 formosus 283
 fortunatus 245
 fraternus 266, 361
frontalis 299
 Fulgoridicida 194, 210, 212, 255, **278**, 285, 310, 352, 353, 355, 359
 fulgoridis 152, 328
 fullawayi 332
 fullwescens 268
 fulviventris 248
 fumipennis Ratzeburg 276
 fumipennis Timberlake 298
fumosipennis 286, 359
 fundus 330, 366
 funeralis 277, 362
 funicularis Bakkendorf 233
 funicularis Hayat et al. 224
 funiculus 330, 366
 fuscicollis 226
 fuscidorsum 298, 362
 fuscipennis Girault 256, 257
 fuscipennis **sp. n.** 170, 186, 188, 239, **240**, 241
 fuscitarsis 345
 fusciventris 229
fuscus 331, 359
 fusciscapus 292
 Gahaniella 162, 166, 180, 192, 212, **278**, 353, 355, 356, 357
 garibaldia (Microterys) 299
 garibaldia (Rhopus) 332, 364
 gaudens 273, 361
 gelechia 257
 gemitus 330
 gemmus 297

- Geniaspidius* 314, 358, 363
Gentakola 157, 160, 194, **278**, 280, 354, 362
gentha 180, 204, 320, **321**
gigantea (Cryptanusia) 262, 361
giganteus (Anagyrodes) 229
gilberti 299
giorgionei 315
Giraultella 255, 256, 357, 360
giraultii 340
glabriscutellum (Cerchysiella) 246, 358, 360
glabriscutellum (Diasula) 169, 192, 263, **264**, 265, 361, 365
globosa 315
gloriae 341, 359
gloriosa 257
gonatopodis 249
gontsharenkoi 298
gordhi 166, 170, 184, 221, **222**
gorodkovi 221, 359
Gounodia 273, 358, 361
gracilis Girault 294, 362
gracilis Hayat 266
gramineus 332
Grandoriella 274, 275
greeni 229
grotii 330, 364
guamensis (Austroencyrtus) 238, 360
guamensis (Caenohomalopoda) 244
guamensis (Ooencyrtus) 309, 310
gunturiensis 293
guttatipes 330, 364
guttofasciatus 298
Gymnoneura 281
Gyranusa 229
Gyranusia 229
Gyranusoidea 158, 162, 180, 230, **280**, 281, 293, 354, 356, 362

Habrolepis 150, **281**, 336, 353, 355, 356
Habrolepistia 256
Habrolepoidea 339, 365
Habrolepopterygis 231
hakki 339
Haligra 184, 194, 196, 220, **281**, 282, 354
Hambletonia 152, 154, 246, **282**, 355, 356
Hamusencyrtus 146, 148, 158, 162, 196, **283**, 354, 356
hardyi 330, 364
hautefeuillei 154, 199, 291, 292
hawaiiensis 150, 288
hawthornei 248, 358
hayati 327
Hazmburkia 283
hederaceus 234
hegeli 330, 364
Helegonatopus 184, 194, 258, 264, **283**, 338, 346, 350, 355, 357, 358, 361, 362
Helmecephala 296, 358, 362

helvolus 160, 298
Hemaenasius 322, 323, 358, 363
Hemaenasoidea 287
hemiaspidiproctis 319
Hemileucocerus 186, 236, 238, **284**, 320, 354
hemipterus Girault (Cheiloneurus) 249, 360
hemipterus Girault (Xenoencyrtus) 348
hemipterus Timberlake 288
Hengata 169, 188, 196, **284**, 285, 353
herbicola 166, 203, 316
Hesperencyrtus 156, **286**, 353, 356
hesperidum Mercet 298
hesperidum Trjapitzin & Khlopunov 299
Heterarthrellus 229
Heterencyrtus 343
Heterococcidoxenus 170, 182, 208, **286**, 354, 356
heterocornis 342
heydeni 342
Hexalis 233
Hexanusia 338, 339, 358, 359, 365
Hexencyrtus 172, 186, **286**, 318, 354, 358, 359, 362
hibisci 269, 359
hipocoon 229
hilli 233
hirsuta 178, 200, 307, **308**
hirtus 330
hispanicus 257
hispidiscutum 247
histrion Förster 293
histrion Mayr 293
hofferi 172, 339, 364
Holanusia 314, 358, 359
Holanusomyia 157, 160, 196, **286**, 354
holbeini 319, 363
Holcothorax 144, 227, **287**, 354, 356
Homalopoda 143, **287**, 353, 356
Homalotylus 139, 142, 166, 174, 176, 196, 202, 259, **287**, 288, 354, 356, 358
homeri 265, 361
hongkongensis 150, 293
hookeri 288
hortensis 269, 359
hospes 325
howardi Girault 330, 364
howardi Hayat et al. 232
howardi Perkins 306, 365
Howardia 268
Howardiella 228, 268, 359
Hungariella 342
hugoi 249, 358, 360
Hunterellus 146, 160, 170, **288**, 354, 355, 358, 362
hyalinipennis 309, 363
hyettus 225
Hypergonatopus 148, 150, 178, 215, 216, 267, **288**, 289, 353, 355, 357, 358, 362

iceryae 289
inconspicuus Doutt 233
inconspicuus Girault 309, 363
Indaphycus 144, 146, 196, 220, **289**, 329, 354
indica Agarwal see *indicus*
indica Agarwal (Neocladia) 306
indica Agarwal et al. 292, 362
indica Ayyar (Comperiella) 256
indica Ayyar (Tetracnemoidea) 146, 342
indica Hayat 343
indica Kerrich 172, 260, 361
indica Mani & Saraswat see *indicus*
indica Shafee 169, 295
indica Shafee et al. (Gyranusoidea) 280
indica Shafee et al. (Leptomastidea) 293
indicus Agarwal (Homalotylus) 287, 288
indicus Agarwal (Syrphophagus) 339
indicus Kerrich see *indica*
indicus Mani & Saraswat 166, 199, 294, 295
indicus Narayanan 341, 352
indicus Narayanan & Subba Rao 306
indicus Shafee et al. (Anagyry) 229, 365
indicus Shafee et al. (Hamusencyrtus) 283
indicus Shafee et al. (Metaphycus) 298
indicus Shafee et al. (Prochiloneurus) 327
inducus Subba Rao (Anagyry) 229, 365
indicus Subba Rao (Microterys) 299
Indoencyrtus 295
inexplicabilis 274
infelix 269
infida 268
injuriola see *injuriolus*
injuriolus 338, 339
inopus 229, 365
inquisitor 339, 364
insidiosus 345
insignis 284
Insleyia 305, 358, 362
insolitus 327
insularis Cameron 242
insularis Howard 247, 360
insularis Timberlake 257, 361
integralis (Doliphoceras) 266
integralis (Mira) 299
integrellus 150, 232
intermedius Hayat et al. 265
intermedius Mercet 330
io Girault 327
io Williams 234
iohneumon 298, 362
ipswichia (Paralitomastix) 316, 363

- ipswichia (Tetracnemoidea) 342
 irvingi 330, 364
 isiharai 157, 276
 Isodromoides 213, 215, **289**, 353,
 355, 356, 358, 359
 Isodromus 174, 202, **289**, 354, 355
 italicus 315
 Ixodiphagus 288, 362

 japonica Tachikawa 304
 japonicus Ashmead 236, 245
 japonicus Howard 176, 186
 japonicus Ishii 273, 362
 javae 257, 361
 javanicus Ferrière 327, 363
 javanicus Mercet 309
 javanus 249
 javensis Girault
 (Cheiloneuromyia) 249
 javensis Girault (Cheiloneurus)
 249
 javensis Girault (Copidosoma)
 358, 361
 javensis Ishii 286
 javensis Subba Rao 340
 johnsoni Girault 316
 johnsoni Howard 309, 310
 jugaeus 145, 188, 247
Jurinia 245

 kaalae 162, 255
 Kakaoburra 190, **289**, 362
 kamathi 246, 360
Kaszabicyrtus 330
 Kataka 164, 172, 190, 199, **290**,
 291
 keatsi (Austrochoreaia) 237, 359
 keatsi (Erencyrtus) 274
 keatsi (Metaphycus) 298, 362
 keatsi (Rhopus) 333, 364
Keatsia 297, 358, 362
 kerrichi Hayat et al. 249
 kerrichi Shafee et al. 299
 kivuensis 229
 koehleri 257, 258, 317
 komabae 257
Kosztarabia 343
 kotynskyi 299
 krishnamurtii 255, 256, 360
Krishnieriella 231
 kumaensis 339, 365
 kuvanae 309

 lacca 251
 lacteiclavus 309, 310
 laeviceps 229
 laevigata 247, 360
 laevigatus see laevigata
 laeviscutum 247, 360
 Lakshaphagus 148, 150, 154, 156,
 199, **291**, 353, 355, 356
 lamasi 274
 lambi 272
 lambinus 349
 Lamennaisia 172, 192, 220, **292**,
 305, 354, 356, 358, 362

 lavarum 309, 363
 laticeps 247
 laticincta 320, 363
 latifrons 249
 laticapulus Alam 298
 laticapulus Girault (Aenasioidea)
 225
 laticapulus Girault (Cheiloneurus)
 249, 360
 laticapulus Girault (Mesanusia) 296
 laticapulus Ishii 276
 laticapulus Prinsloo & Annecke
 333, 364
 laticapulus Shafee et al. 298
 laticutulum 237
 laysanensis 333
 lecaniorum 269
 Leefmansia 202, **292**, 353
 leichhardtii 238
 lemniscata 190, 256
 lepelleyi 306
Lepidaphycus 287
 lepidopterophagus 257, 258, 361
Leptanusia 230, 293, 359
 Leptomastidea 158, 170, 176, 182,
 244, 280, 281, **292**, 293, 354, 356
 Leptomastix 170, 174, 182, 230,
293, 354, 356, 359, 361
Leptorhopala 248
 leucocerus 309
Leuroceroides 226, 357, 359
 Leurocerus 150, 152, **293**, 312,
 323, 327, 328, 351, 353, 354, 356
 liaoi 349
 lichtensiae (Metaphycus) 298
 lichtensiae (Microterys) 299
 lilacini 229
Limastotix 257
 lindingaspidis 273, 362
 lindus 221, 359
 lineatipes 229, 359
Liocarus 325
 Liothorax 258, 263, 264, 265, 361,
 365
Lissencyrtus 340
liszti 254, 358
Litomastiellus 257
Litomastix 257, 258, 309, 361
Lonchocerus 299
 longfellowi 318
 longiartus 258, 361
 longiclavatus Hayat et al. 224
 longiclavatus Shafee et al.
 (Metaphycus) 298
 longiclavatus Shafee et al.
 (Rhopus) 333
 longicornis Hayat et al. 249
 longicornis Hayat & Verma 170,
 232
 longicornis Khan & Shafee 293
 longicornis sp. n. 158, 204, **323**,
 324
 longifasciata 241
 longifasciatipennis 294, 362
 longifuniculus 299
 longimarginalis 244

 longipennis 229
 longiscapus Girault 231
 longiscapus Khan & Agarwal 293
 longissimus 330, 366
 longistylus 330, 364
 longiventris 229
 lopezi 273, 361
 lotae (Copidosoma) 257, 258, 361
 lotae (Neblatticida) 304, 362
 lotae (Parectromoidella) 319, 320
 lounsburyi 298
 lowelli (Coccidoctonus) 254, 307,
 360
 lowelli (Parectromoidella) 157,
 204, 320, 363
 lucetius 258, 361, 365
 luciani 339, 365
 luctuosus 343
 lunulata 224, 359
 lusitanicum 330
 luteus 304, 362
 lutheri 340, 365
Lutheria 294, 365
 Lutherisca 154, 182, 216, **294**, 341,
 355, 365
 luzonica 262
 lycoeniphila 286
Lymanera 255, 256, 357, 360
 lyperosae 340, 365

mackayensis 250, 358
 macrocerus 277, 362, 365
 maculata Ishii see maculatum
 maculatipes 318
 maculatum Ishii 258
 maculatus Agarwal 298
 maculatus Subba Rao 233
 maculipennis De Santis 342
 maculipennis Ratzeburg 245
 madgaensis 265
Magellanana 272, 357
 magniclava Girault 241
 magniclava Hayat & Subba Rao
 341, 365
 magniocularis 314, 359, 363
 magniscutellum 320
 magnithorax 274, 362
 Mahencyrtus 166, 176, 178, 188,
 196, 208, **294**, 321, 350, 353,
 358, 362
 major Ferrière 309
 major Perkins (Anagyrus) 229
 major Perkins (Ectopognatha)
 267
 malabarensis 298
 malayensis Ferrière 309
 malayensis Noyes & Chua 249
 malayensis Subba Rao 340
 malenotti 170, 318, 363
 malenotus 273, 361
 mamitus 339, 365
 manaliensis 345
mandibularis Girault 250, 358
 mandibularis Hayat et al. 253, 360
 Manicnemus 166, 176, 199, **294**,
 305, 354

- manilae 258, 361
 margiscutellum (Cheiloneurus) 249, 360
 margiscutellum (Xenostyxis) 348
 marlatti 160, 333
 marmoratipes 273
 marquesanus 272, 361
 martinii 306
 Marxella 143, **295**, 354
Masencyrtus 283
 Mashhoodia 169, 180, 206, 230, **295**, 354, 356
 Mashhoodiella 174, 178, 200, **295**, 314, 355
Masia 342
 matranus 322
 matritensis 229
 mauiensis 160, 255
 maxima Mercet 297
 maximus Girsult 228, 229
 Mayridia 166, 194, 212, 215, 290, 291, **295**, 296, 350, 355, 356
 mayurai 224, 359
 mazzinini (Cheiloneurus) 249, 360
 mazzinini (Psyllaephagus) 330, 364
 megalarus 274
 megymeni 348
Melanaphycus 298
 melanicis 347
 mellea 273, 361
 melleicorpus 329, 363
 memnonicus 298
Mendozaeniella 287
 meniscocephalus 227
 Meniscocephalus 133, 210, 212, 215, **296**, 353, 354, 355, 358, 362
Mercetencyrtus 292, 358
 merceti Compere 256
 merceti Masi 339, 365
Mercetia 330
Mercetiella 298
 mercurius 330, 364
 Mesanusia 168, 208, 234, 241, **296**, 298, 350, 353, 355, 358, 362
Mesanusomyia 333, 358, 364
 Mesastymachus 274, **296**, 354, 362
Mesencyrtus 257, 357, 361
 Mesocalocerinus 187, 250, **297**, 353
Mesocopidosomyia 257, 258, 357, 361
 mesograptae 338
 Mesorhopella 144, **297**, 318, 353
Metacrapterocerus 245
Metacheiloneurus 249
 metallicus Girault (Ooencyrtus) 309, 310
 metallicus Girault (Syrphophagus) 339, 365
 metallicus Mercet 294
Metallon 268
Metallonella 318, 345
Metallonoidea 349
 Metaphaenodiscus 180, 215, 225, 227, 251, **297**, 355, 356, 358, 362
- Metaphycus 160, 164, 200, 206, 225, 226, 233, 234, 241, **298**, 302, 350, 353, 354, 355, 356, 358, 362
Metaplatycerus 250
Metaprionomitus 330
Metapterencyrtus 349
 mexicanus Girault 346
 mexicanus Howard (Blepyrus) 242
 mexicanus Howard (Metaphycus) 298
 mexicanus Timberlake 288
Microencyrtus 272, 358, 361
 microgaster 288
microphagus 349
Microrhopus 226, 227, 357, 359
Microsphenus 286
 Microterys 148, 150, 156, 176, 180, 202, 247, 291, 292, **299**, 304, 317, 339, 353, 355, 356, 360, 362
 Mimencyrtus see Mirrencyrtus
 minor 267
 minuta Girault (Australia) 172, 237
 minuta Girault (Fulgoridicida) 278
 minutella see minutellus
 minutellus 331, 364
 minutissimus 272, 361
 minutum De Santis 243
 minutus Girault (Adelencyrtus) 224, 359
 Mira 146, 234, 268, 290, 296, **299**, 336, 354
 mirabilis Brèthes (Encyrtus) 269
 mirabilis Brèthes (Homalotylus) 287
 mirabilis Girault 232
 mirabilis Westwood 148, 245
 mirabilissima 300
Mirastymachus 332
Mirocerus 330
 mirisimilis 162, 323
Mirrencyrtus 246, 357, 358, 360
Mirsyrphophagus 277, 358, 362
 mirus Girault 229, 359
 mirus Hayat 336
 mirzai Agarwal 230, 280, 362
 mirzai Shafee et al. 299
 moderatus 162, 224
 moestus 249
 molokaiensis 288
 Monodiscodes 225, 251
 Monstranusia 152, **300**, 354
 montivagus 273, 361
 morio 325
 Mozartella 144, 220, 234, **300**, 353
 mucora 299
 mudigerensis 164, 199, 290, 291
 muironi 238
 Muluencyrtus 178, 200, 214, **300**, 301, 354
 mumfordi 229
 mundus 288
 myersi 244, 245
Mymariella 235
 mymaricoides 148, 196, 283
- Myrmencyrtus* 230, 357, 359
 mysorensis 288, 362
- nacoleiae 146, 258, 259, 361
 nagaii 244
 nassau 234
 Nassauia 143, **302**, 354, 355
 Nathismusia 142, 178, 200, **302**, 303, 354
 navae 346
 Neabrolepoideus 178, 250, **303**, 353
 Neanagyrus 217, 219, **303**, 353, 355, 358, 362
 nearctica 339
Neasteropaeus 272, 339, 358, 361, 364, 365
 Neastymachus 160, 164, 188, 208, **304**, 353, 355, 358, 362
 Neblatticida 156, 241, 250, **304**, 341, 353, 359, 362
 Negeniaspidius 192, **305**, 354
 nemis 172, 203, 312, **313**
 nemoralis 297
Neoadelencyrtus 253, 357, 360
Neoaeenasioidea 287
 neocaledonensis 281
 Neocharitopus 182, 200, 218, **305**, 354, 356, 358, 362
Neochrysopophilus 259, 357, 361
 Neocladella 152, 162, 166, **305**, 353, 358, 359
 Neocladia 142, 178, 229, **306**, 316, 354, 355, 359, 365
 Neococcidencyrtus 348
Neocopidosoma 257
Neocopidosomyia 289, 358, 359
 Neodiscodes 154, 170, 225, **306**, 355, 356
 Neodusmetia 146, 148, 200, **306**, 355, 356
 Neoplatycerus 152, 246, **306**, 355, 356
Neoprophiloneurus 327
 Neorhopus 143, **307**, 354, 356, 359
Neoxanthoencyrtus 283
 neoexenus 331, 366
 nepalensis 249
 nepticulae 314
 Nerissa 341
Nesencyrtus 255
 nesus 157, 208, 343, **344**
Nesyrphophagus 338, 339, 358, 359, 364
 newcombi 299
 Nezarhopalus 168, 254, 268, 307, 332, 353, 361, 364
 nietneri 299
 niger Girault see nigra
 niger Masi 259
 niger Riek (Neanagyrus) 303, 362
 niger Riek (Xenoencyrtus) 150, 348
 nigra Girault (Ageniaspis) 226, 227, 359
 nigra Girault (Casca) 274

- nigra* Girault (Cerchysiella) 246, 257
nigrella 246, 358
nigriaxillae 289
nigricans Blanchard 253
nigricans Perkins 158, 170, 266
nigriceps Girault 233
nigriceps Noyes 328
nigriclavatus 319
nigriclavus 332, 333
nigricornis Girault
 (Prochiloneurus) 327, 363
nigrocornis Girault
 (Syrphophagus) 338, 339, 365
nigricornis Hayat 172, 178, 267
nigrocornis Hayat et al. 250
nigricornis Timberlake 229
nigricorpus Girault 278
nigricorpus Shafee et al. 230
nigriflagellum Girault (Anagyrus)
 230, 359
nigriflagellum Girault
 (Prochiloneurus) 327, 363
nigritegulae 293
nigritus 288
nigrivarius 298, 362
nigroclavatus 332
nigrocoxalis 170, 293
nigroradiculatus 230
nikolskajae 283
Nikolskiella 304, 358
nipaecocci 288
nitens 298
nitidus 294, 362
niveiclava 164, 320
niveipes 220, 221, 359
nobilis Girault 249, 358
nobilis Nees 305
Nobrimus 287
nonaericornis 315, 331
Notoencyrtus 298
novaezealandiae 223
novimandibularis 250, 358, 360
novipurpureus 331, 364
noxius 250
nudipennis 178, 200, 300, **301**

oahuensis 288
Oaphycus 298, 358
obenbergeri 329, 363
obscura Girault (Pseudectroma)
 329
obscurus Girault (Syrphophagus)
 339, 365
obscurus Hayat 184, 227, 228
occidentalis 339, 365
occultans 294
oceanicus 224, 359
ochraceipes 162, 253
ochroleucus 310
oculata see *oculatus*
oculatus 287, 288
odacon 229, 359, 365
odonaspidis 224
odyneri 162, 190, 225
Olypusa 178, 200, 214, 301, **307**,
 308, 354
Omphalencyrtus 253, 254, 357, 360
Ooencyrtoides 330
Ooencyrtus 148, 169, 172, 180,
 182, 184, 188, 194, 200, 202,
 204, 210, 212, 217, 219, 226,
 228, 233, 268, 274, 278, 285,
 289, 292, 296, **309**, 310, 311,
 319, 326, 327, 339, 346, 348,
 350, 353, 355, 356, 357, 358,
 362, 363, 365
orbi 255
orbitalis Thomson 293
orbitalis Timberlake 230
orci 288
orientalis Agarwal 305
orientalis Ferrière 146, 328
orientalis Subba Rao 244
orientalis Trjapitzin 348
ornatipennis 319
orro 172, 316
osborni 255
Ovaloencyrtus 154, 156, 178, 200,
 215, **310**, 311, 319, 348, 353
ovi 224
ovidivorus 309, 363
Ovidoencyrtus 217, **312**, 354, 355
oviductus (Coccidoctonus) 254,
 360
oviductus (Prochiloneurus) 327
ovivorus 293

pachypsyllae 330
pachyscapha 314, 315, 359
pacificus 172, 309
pacorus 320, 363, 365
Pakencyrtus 343
pakistanensis Ahmad 208, 343
pakistanensis Ahmad & Ghani
 154, 162, 312
Paksimmondsius 154, 156, 294,
 312, 351, 354, 356
pallidiceps 255, 256, 361
pallidipes Ashmead 309, 363
pallidipes Girault (Ovidoencyrtus)
 312
pallidipes Girault (Psyllaephagus)
 331, 364
pallipes 343
paludatus 274
Paludencyrtus 283
panchganja 248
pantherina 228
papilionidis 309, 363
papilionis 309
Papuna 172, 196, 203, **312**, 313,
 353
Parablastothrix 140, 295, **314**, 356,
 359, 363
Parablatiicida 142, 164, 168, 170,
 203, **314**, 315, 323, 353, 358,
 359, 363, 365
Paracaenocerus 257, 258, 314, 357,
 359, 361
Paracalocerinus 342
Paraceraptrocercus 152, **315**, 353,
 355
Parachalcerinys 217, 237, **315**,
 331, 353
Paracheilonurus 249, 357
Parachrysopophagus 327
Paracladella 210, 229, **315**, 316,
 354, 359
Paraclausenia 166, 180, 203, 217,
 316, 354
Paracopidosomopsis 257, 258,
 309, 361, 363
paradiscicus 265
paradoxus 331, 366
Paraenasomyia 172, 186, 194, 212,
 213, 254, **316**, 330, 331, 339,
 353, 356, 358, 359, 364
Parageniaspis 277, 358, 362, 365
Parahomalopoda 325
Paraleptomastix 214, 293, 316, 354
Paraleurocerus Agarwal 325
Paraleurocerus Girault 252, 287
Paralitomastix 217, **316**, 317, 354,
 356, 363
Parallelaptera 233
Paranathrix 158, 174, 180, **317**,
 354, 356
Paranusia Brèthes 229, 231
Paranusia Girault 231
Paraphaenodiscus 148, 156, 202,
 227, 286, **317**, 353, 355, 363
Paraphycus 162, 184, 298, **317**,
 318, 354
Paraplatycerus 250
Parapsilophrys 257
Pararhopella 144, 297, **318**, 353
Paraschedius 172, 178, 188, 204,
 318, 353, 356
Parastenoterys 214, 286, **318**, 320,
 334, 340, 354, 363
Parasteropaesus 257, 258, 357, 361
Parasyrphophagus 221, 265, 277,
 336, 337, 358, 359, 361, 362,
 364, 365
Parataneostigma 289
Paratetracnemoidea 170, 182, 225,
 318, 354, 358, 363
Paratetralophidea 154, 156, 214,
 311, **319**, 348, 353, 355
Parechthrodryinus 176, 208, 294,
 319, 347, 353, 355, 356
Parectromoidella 146, 154, 157,
 158, 160, 176, 202, 204, 262,
 263, 319, 347, 354, 363, 365
Parectromoides 192, 213, **320**,
 354, 363
Parencyrtomyia 164, 174, 200,
 214, **320**, 354
parisoti 234
parkeri (Copidosoma) 258, 361
parkeri (Metaphycus) 298, 362
particornis 347, 365
partipes 250, 358
parlatoriae 235
partipilum 350
parus 317, 363
parvula 332
parvus Girault 339, 365

- parvus Hayat 267
 parvus Kerrich 306
 parvus Riek 331
 pasteuri 250, 358, 360
 Pasulinia 180, 204, 212, **320**, 321, 353
Pauridia 255, 357, 360
 peckhami 268
 pectinatum 229
 pegasus 331, 364
 peninsularis 342
 penni 331, 364
 Pentacladocerus 198, 247, **322**, 354
Pentacnemus 257, 357, 361
Pentalitomastix 258, 309, 357, 361, 362
 Pentelicus 154, 162, 168, 243, 293, **322**, 323, 328, 354, 358, 363
 pentlandensis 348
 perbellus 326
 perubius 339, 365
 peregrina see peregrinus
 peregrinus 182, 255, 360
 perfuscipennis 304, 362
 Perissopterus 274
 perkinsi Subba Rao 229, 359
 perkinsi Timberlake 246, 360
 perminutus (Coccidoxenoides) 255, 359
 perminutus (Copidosomopsis) 258, 259
 perplexa Girault 332
 perplexus Girault see perplexa
 perplexus Riek 331
 perpulcher 249, 250
 perseverans 257, 258, 359, 361
 persimilis 241
 peruvienensis 325
 perversus 208, 341
 peyelaie 330
Pezaphycus 329, 358, 363
Pezobius 268
Phaenodiscoides 340, 358, 365
Phaenodiscus 343, 365
Phauloencyrtus 162, 168, 315, **323**, 353
 phenacocci 158, 280
 philippinensis 180, 277
Philoponectroma 229
 Philosindia 158, 160, 204, **323**, 353
Pholidoceras 266, 332
Pholidoceroles 332
 phongi 309
 phoanæ 262
 phragmitis 162, 186, 236
Phyllotibia 306
 pia 256
 piceae 342
 pilosigena 347
 pilosithorax 236
 pinicola 248
 piso 332
Placocerus 342
 Plagiomerus 143, **325**, 353, 356
 planchoniae 249, 360
 planiscutellum 247, 360
 planus 146, 196, 289
 platicera 245
 platycerus 299
 Platyrrhopus 160, 168, **325**, 354, 356
 plethoricus 259, 361
 podontiae 309
poeta 250, 358
poeta (Aenasomyiella) 226, 359,
poeta (Carabunia) 244, 245, 360
 polychromus 268
 ponomarenkoi 283
 poonensis 235
 porteri 229
 portoricensis Crawford 346
 portoricensis Dozier 298
 positus 331
 Praeurocerus 152, 204, **325**, 354, 356
 pretiosa Timberlake 277
 pretiosus Mercet 305
 prima Mercet 234
 primus Howard 231
 Prionomastix 172, 182, 200, 210, 276, 308, **325**, 354, 355
 Prionomitoides 184, **326**, 353
 Prionomitus 246, 360
 probus 331
 procellosa 342, 365
 procellosus see procellosa
 procerus 295
 Procheiloneurus 148, 150, 154, 178, 198, 202, **326**, 353, 358, 363
Prochiloneuroides 327
 Prochiloneurus 148, 150, 154, 156, 178, 198, 202, 326, **327**, 343, 353, 355, 356, 357, 363
 prodeniae 341
 prolatus 331
 Proleuroceroides 176, 206, 207, 294, **327**, 354, 355, 363
 Proleurocerus 152, 154, 293, 323, 327, **328**, 354, 355
Prolitomastix 246, 357
 propinquus 277
Propysyllaephagus 330
Prorhopoideus 269
 prosperpinensis 269, 359, 361
 prosperis 339, 365
Protanagyris 229
 Protynaricoides 169, 180, 186, 190, 204, 213, **328**, 353, 356, 363
Protynarichus 294, 358
 proxima see proximus
 proximus 297
Pseudanasius 225
Pseudanasia 256
Pseudaphycus 144, 146, 220, 273, **328**, 354, 356
Pseudectroma 144, 146, 220, 289, 300, 328, **329**, 354, 356, 358, 363
Pseudencyrtella 257, 357, 361
Pseudencyrtus 313, 316
Pseudhomalopoda 243, 244
Pseudmicroterys 304, 358, 362
 pseudococci Brèthes 293
 pseudococci Girault 230
 pseudococcina 152, 282, 283
 Pseudococcobius 160, 162, 174, 198, 202, 298, **329**, 354, 356, 358, 363
Pseudolitomastix Eady 258, 259, 357, 361
Pseudolitomastix Risbec 309
 pseudophanes 283
Psilomirinus 328
 psyllae 254, 360
 Psyllaephagus 154, 158, 160, 162, 164, 168, 172, 178, 184, 186, 196, 212, 213, 214, 217, 219, 225, 242, 247, 263, 304, 315, 326, **330**, 331, 352, 353, 355, 357, 358, 359, 361, 363, 364, 365, 366
 Psyllaphycus 208, 332, 353, 355
Psylledontus 345
Psyllencyrtus 330
Pteromalencyrtus 305, 358, 359
 pulchellus 327
 pulcher Girault (Cheiloneurus) 249
 pulchra Ashmead 249
 pulchra Girault (Schilleriella) 338
 pulchra Mercet 295, 296
 pulchricornis Ashmead 349
 pulchricornis Hayat & Verma 283
 pulchripennis Girault (Holanusomyia) 157, 196, 286
 pulchripennis Girault (Xenanusia) 347
 pulchripennis Mercet 342
 punctata (Cowperia) 259, 260, 365
 punctaticeps 229
 punctatifrons 268, 272
 punctatinotum 242
 punctatiscutum 330, 331, 364
 punctatus (Parastenoterys) 318
 punctifrons 266, 361
 punctiscutellum 247, 360
 punctulatus 230
 puparia 339, 365
 purpurea Ishii 251
 purpureicinctus 250, 358, 360
 purpureicornus 162, 332
 purpureiscutellum 333, 364
 purpureiventris (Cheiloneurus) 250
 purpureiventris (Microterys) 299
 purpureus Girault 330, 331, 364
 pyrillae Crawford 327, 363
 pyrillae Mani 150, 250
 pyrillae Shafee et al. 327
 qadrii Hayat et al. 230, 359
 qadrii Shafee et al. 333
 quadrianellus 331, 366
 quadricolor (Charitopus) 248, 360
 quadricolor (Cheiloneurus) 250
 quadricylus 331
 quadridentata (Lamennaisia) 292
 quadridentatus (Adelencyrtus) 224

- quadridentatus* (Neocladella) 305, 359
quadriguttus 224, 359
Quaylea 254
quercicola 339, 365
quinquedentatus 224, 359
quinqueguttata Motschulsky 244
quinqueguttatus Girault 329, 363

Raffaellia 144, 259, **332**, 354, 358
raffaellini 339, 365
Raffaellisca 332, 358
rageaui 340
Ramalia 297
ramosa see *ramosus*
ramosus 330, 331, 364
Raphaelana 326, 358
rara 250, 360
regalis 320, 363
regis 250, 360
resolutus 331
reticulata 298
rex 327
Rhinoencyrtus 225, 318, 358, 363
Rhopalencyrtoidea 162, 172, 186, 200, 254, **332**, 341, 352, 353, 358, 360, 364, 365
Rhopoidea 220
Rhopomorphus 266
Rhopus 146, 148, 162, 182, 204, 206, 207, 307, **332**, 354, 356, 364
Rhytidothorax 160, 164, 170, 176, 188, 190, 194, 206, 207, 213, 214, 220, 275, 276, 286, 318, 320, **333**, 334, 340, 354, 358, 364
Richardisus 349
richteri (Marxella) 295
richteri (Psyllaephagus) 331, 364
Rileya 250
robustus 247
Rotrencyrtus 224
rotundiceps (Epidinocarsis) 272, 361
rouxi 150, 281
Ruandella 335
Ruanderoma 164, 174, 207, **334**, 335, 355
rubens 331, 364
rubescens 234
rubricatus 348
rufescens 250
rufipleurus 235
rufiscapus 235
ruschkai 232
Ruskiniana 150, **336**, 353

Sabirella 292, 358, 362
sacchari Alam 333
sacchari Subba Rao 180, 251
saccharicola 230
sagarensis 288
saintpierrei 256, 278, 352
saipenensis 230
saissetiae Gahan 176, 341
saissetiae Noyes & Chua 250
saissetiae Timberlake 162, 180, 192, 278

saissetiae Yasumatsu & Yoshimura 269, 361
Sakencyrtus 146, 148, 174, 202, 207, 208, **336**, 354
salacon 258, 361, 365
salemensis 293
sanguineus 333
sanguinithorax (Metaphycus) 298, 362
sanguinithorax (Syrphophagus) 339, 359
sangwani 148, 200, 306
sankarani sp. n. 164, 207, 334, **335**
sankarani Subba Rao 343
Saprencyrtus 166, 174, 178, 208, 214, **336**, 353, 356, 364, 365
Saronotum 249
sawadai 230
Scelioencyrtus 283, 332, 333, 364
sceptriger 299
Sceptrophorus 299
Schedioides 283
Schedius 309, 314, 363
Schillerana 244, 357, 360
Schilleria 338
Schillieriella 146, **338**, 354
schlechtendali 170, 286
schwarzi 277
Scottes 310
scutellata 246, 247, 360
scutellatus see *scutellata*
scutomaculatus 230
secunda Girault (Nassauia) 302
secunda Girault (Tetracnemioidea) 342
secunda Trjapitzin 304
secundus see *secunda*
secundus Girault (Cocidencyrtus) 253, 360
secundus Girault (Trechnites) 345
segestes 309
semialbus 298, 362
semiargenteus 231, 358
semiargentipes 265, 361
semicitripes 331, 364
semidaliphagus 346
semiflavus 333
semifulvus 352
semiluteus 333
seminigrilavus 250
senegalensis 306
sericea 242
sericeus see *sericea*
sexguttata 244
sexguttatipennis (Epitetracnemus) 273
sexguttatipennis (Ruskiniana) 336
sexramosus 255
shadsakus 306
shafeei Hayat et al. 224
shafeei Hayat & Subba Rao 293
shahidi 230
shakespearei (Copidosoma) 258
shakespearei (Ooencyrtus) 309, 363
Shakespeareia 330

shikokuensis 243
siccus 134
siddiqii 242, 360
sidneyi (Aenasiella) 224, 331, 359
sidneyi (Raffaellia) 332
signata 244, 358
silvae 296, 297
similis Ashmead 287
similis Girault 230, 359
similis Ishii 245
similis Prinsloo 339, 365
similis Riek 331
simmondsi 224
simpliciscapus 278
simpliciscutellum 249
sinemarginis 152, 211, 350, **351**
singularis 293
sinicus 299
smaragdus 331, 364
snoflaki 234
solidus Hayat 146, 220
solidus Howard 224, 353
southwoodi 178, 200, 302, **303**
Spaniopterus 143, 146, **338**, 353, 356
speciosa (Mesanusia) 208, 234, 296, 298, 350, 353
speciosus (Ablerus) 274
speciosus (Zarhopaloides) 350
sphingidarum 309
spica 230, 359
spinosa 169, 196, 284, **285**
spinozai 299
splendens 152, 250, 251
spoliata 170, 235
spondyliaspidis 331, 364
spongitus 331, 364
stanleyi 298
Stenoteropsis 220, 309, **338**, 346, 363
Stenoterys 293
Sterrhocoma 293
stigmatiferus 348
striatithorax 226, 227, 359
stylatus 232
subalbipes 230
subapterus 245
subbaraoi 306
subflaviceps 230, 359
subgiganteus 331, 359, 364
sublimis 250, 358
submetallicus 309
submicans 349
subproximus 230
suburbis 331, 359, 364
sumavicus 343
sumatraensis 260, 361
Superprionomitus 295
Swazencyrtus 333, 358, 364
swederi 268
swezeyi Fullaway 309
swezeyi Timberlake (Anagryus) 158, 184, 230
swezeyi Timberlake (Coelopencyrtus) 255
sydneyensis 231, 358

- sylvius* 299
Symphycus 314, 315, 358, 363, 366
Synaspidia 277
syntomozae 330
Syrphidencyrus 338
Syrphophagus 172, 184, 186, 194, 196, 204, 213, 219, 254, 268, 338, 339, 341, 353, 355, 357, 358, 359, 364, 365
Szelenioloa 164, 339, 353, 356, 365
- tachardiæ 172
Tachardiaephagus 172, 188, 204, 206, 340, 347, 353, 356
tachikawai Hoffer 339, 365
tachikawai Shafee et al. 170, 240, 360
tachikawai Subba Rao 306, 307
Tachinacphagus 340
Tachinaephagus 166, 176, 180, 188, 190, 198, 206, 208, 213, 318, 320, 334, 340, 356, 357, 358, 359, 365
taeniatus 339, 365
Taftia 176, 206, 210, 231, 283, 294, 341, 355, 356
takenakai 247, 360
Tanaomastix 293
tantaleus 267, 361
tarsalis 236
tarsata 228, 359
tarsius 303, 362
Tassonia 184, 219, 341, 353, 355, 359, 365
tassoniaeformis 341, 359
taurus 327, 363
Telegraphus 245
Teleterebratus 168, 200, 208, 254, 332, 341, 352, 353, 356, 365
tenuicornis 232
terebratus 254, 360
terminalis 288
terraefilius 331, 364
terryi 174, 329
tertius 342, 359
testacea Motschulsky 244
testaceipes 287
testaceus Agarwal 327
Tetracladia 342
Tetracnemella 309, 331, 346, 358, 362, 363, 364
Tetracnemoidea 143, 144, 146, 231, 341, 350, 354, 358, 359, 365
Tetracnemopsis 341
Tetracnemus 198, 341, 342, 354, 356
Tetralophidea 225, 294, 297, 342
Tetralophiellus 342
Tetrastichus 299
texana see *texanus*
texanus (*Tetracnemus*) 342
texanus (*Acerophagus*) 220
thackerayi 319, 320
thailandicus 317
Thomsoniella 343
Thomsonisca 162, 166, 208, 343, 348, 353, 356
thomsoniscae 349
thoracicus 340
thoreauini 316
tibimaculatus 230
timberlakei 298
Timberlakia 329, 358
Tineophoctonus 198, 327, 343, 353, 356, 357
Tobiasia 250
Tongyus 157, 158, 208, 343, 344, 354
Trechnites 134, 144, 148, 253, 345, 353, 355, 365
trellesi 330
triangularis 289, 359
Trichomasthus 164, 169, 176, 178, 194, 212, 215, 233, 243, 310, 346, 353, 355, 356
tricinctus 298, 362
triclavata 220, 221
tricolor (*Charitopus*) 248, 358, 360
tricolor (*Epidinocarsis*) 272
tricolor (*Ooencyrtus*) 309, 363
tricolor (*Rhopus*) 333, 364
trifasciata Girault 244
trifasciata Saraswat 157, 194, 278, 280, 362
triguttatipennis 326
triguttatus 299
trilongifasciata 293
Trimorphocerus 243
trinidadensis nom. n. 314, 365
trinidadensis Crawford 162, 254
trinidadensis Kerrich 273, 361
Trjapitzinellus 192, 218, 346, 354, 355
Tropidophryne 160, 246, 346, 355, 356, 358
troupi 340
truncatellum 258
turbulentus 331, 364
turneri (*Metaphycus*) 298, 362
turneri (*Psyllaephagus*) 331, 364
Tyndarichoides 294, 358
Tyndarichus 160, 166, 208, 319, 346, 347, 353, 356, 357, 365
Tyndaricopsis 160, 166, 208, 347, 353, 356, 357
typica 343
- umbilicata* (*Cerchysiella*) 246
umbilicata see *umbilicatus*
umbilicatus (*Metaphaenodiscus*) 297, 362
uncinatus 331, 366
unguttatus 339, 359
unicinctipes 314, 363
unicolor 250
unifasciata 256
unus 331
urocerus 247
usticius 331, 359
utilis Noyes 246, 360
utilis Riek 331, 366
utilis Timberlake 146, 328
valparianus 327
varia (*Cryptanusia*) 262
varia see *varius*
varicornis (*Pentelicus*) 322, 363
varicornis (*Syrphophagus*) 339, 365
varicornis (*Paralitomastix*) 316, 317
variocelli 250, 358
varithorax 230, 359
varipes 320, 363
varius (*Metaphycus*) 298, 362
variventris 257, 258, 361
varleyellus 266
vendicus 330
verdini 298, 362
Verdunia 257
verus 317
vespertinus 314
vestonicensis 246
vibrans 299
vidua 314, 363
viduus see *vidua*
vinculum 250, 358
violacea 306, 365
virens 245
viridiceps 164, 192, 263
viridiflava 265, 266, 361
viridis 152, 204, 325
viridiscutellum (*Isodromoides*) 289, 359
viridiscutellum (*Prionomitoides*) 326
viridiscutellum (*Psyllaephagus*) 331, 364
viridiscutellum (*Trechnites*) 345, 365
viridiscutum 250, 360
voltai 348
Vosleria 244, 357, 358
vulcanus 288
- wallacei* 253, 360
walshi 258, 361
Waterstonia 234
westralis 331
westwoodi Cockerell 341
westwoodi Girault 249, 250, 360
whittieri 254
Whittieria 347, 353
worcesteri 154, 331, 364
wundti (*Paraphaenodiscus*) 317
wundti (*Psyllaephagus*) 331, 364
- Xanthoencyrtus* 236, 332, 364
xanthogaster Girault 309, 363
xanthogaster Perkins 230
xanthopus 247
Xenania 146, 150, 262, 347, 354, 361, 465
Xenaphycus 318
Xenoencyrtus 148, 150, 178, 311, 319, 348, 353, 355

- Xenostryxis 186, 196, 211, **348**,
353
xenus 331
Xesmatia 309, 358, 363
xi 331, 266
Xiphomastix 229
xuthus 331, 364
xylocopae 255, 361
- yasumatsui Myartseva &
Trjapitzin 297
yasumatsui Subba Rao 232
yasumatsui Tachikawa &
Valentine 350
- yasumatsui Trjapitzin 250
Yasumatsuiola 157, 160, 211, 287,
348, 354
ypsilon 331, 366
- zameis 332, 364, 365
Zamenhofella 194, **348**
Zaomencyrtus 257, 258, 357, 361
Zaomma 150, 241, 267, 321, 349,
353, 356, 357
Zaommoencyrtus 170, 182, 211,
218, 247, 280, 322, **349**, 354, 356
Zaomommoencyrtus 226, 357, 359
Zaplatycerus 346
- Zarhopaloides 164, 200, 208, 218,
256, 294, **349**, 353, 354, 357,
362, 365
Zealandencyrtus 143, 231, **350**,
354, 356
zealandicus 340
zebinia 353
zebratus 298
Zeteticontus 246, 247, 357, 360
zetterstedti 154, 273, 362
Zooencyrtus 158, 188, **350**, 353
Zozoros 152, 154, 211, 293, 312,
350, 351
zululandiae 328

British Museum (Natural History)

Milkweed butterflies: their cladistics and biology

P. R. Ackery & R. I. Vane-Wright

The Danainae, a subfamily of the Nymphalidae, contains only some 150 species, yet aspects of their biology have stimulated far more attention than can be justified by species numbers alone. In recent years, an expansive literature has grown, considering aspects of their courtship and pre-courtship behaviour, migration, larval hostplant associations, mimicry and genetics. The popularity of danaines among biologists can certainly be attributed to this combination, within one small group, of so many of the factors that make butterflies such an interesting group to study. The obvious need to place this wealth of biological data within an acceptable systematic framework provided the impetus for this volume.

Started eight years ago within the conventions of evolution by natural selection and Hennig's phylogenetic systematics, the book is now largely about natural history (what the animals have and do, where they live and how they develop) and natural groups – as revealed by a form of analysis approaching that practised by the new school of 'transformed cladistics'. The authors have prepared a handbook that will appeal to a wide range of biologists, from museum taxonomists to field ecologists.

424 pp (approx.), 12 pp colour, 73 b/w plates, line and graphic illustrations, maps, extensive bibliography. ISBN 0 565 00893 5. Publication September 1984. Price £50, prepublication price £45.

Titles to be published in Volume 48

Gelechiid moths of the genus *Mirificarma*.

By Linda M. Pitkin

Macronematine caddisflies of the genus *Amphipsyche* (Trichoptera: Hydropsychidae).

By P. C. Barnard

A review of the genera of Indo-Pacific Encyrtidae (Hymenoptera: Chalcidoidea).

By John S. Noyes & M. Hayat

BOUND
15 DEC 1987

