

LIBRARY OF  
THE NEW YORK BOTANICAL GARDEN

Given by C. J. Cox, Esq.  
1903

September 1899

R. W. Gibson. Inv.









JOURNAL  
OF THE  
ROYAL  
MICROSCOPICAL SOCIETY;

CONTAINING ITS TRANSACTIONS AND PROCEEDINGS,  
AND A SUMMARY OF CURRENT RESEARCHES RELATING TO  
ZOOLOGY AND BOTANY  
(principally Invertebrata and Cryptogamia).

MICROSCOPY, &c.

LIBRARY  
NEW YORK  
BOTANICAL  
GARDEN

*Edited by*

**FRANK CRISP, LL.B., B.A.,**

*One of the Secretaries of the Society*

*and a Vice-President and Treasurer of the Linnean Society of London;*

WITH THE ASSISTANCE OF THE PUBLICATION COMMITTEE AND

**A. W. BENNETT, M.A., B.Sc., F.L.S.,**  
*Lecturer on Botany at St. Thomas's Hospital,*

**F. JEFFREY BELL, M.A., F.Z.S.,**  
*Professor of Comparative Anatomy in King's College,*

**JOHN MAYALL, JUN., F.Z.S.,**

**R. G. HEBB, M.A., M.D. (Cantab.),**

AND

**J. ARTHUR THOMSON, M.A.,**  
*Lecturer on Zoology in the School of Medicine, Edinburgh,*

FELLOWS OF THE SOCIETY.

FOR THE YEAR

1888.

Part 2.



PUBLISHED FOR THE SOCIETY BY  
**WILLIAMS & NORGATE,**  
LONDON AND EDINBURGH.

1888

pts. 4-6

1888. Part 4.

AUGUST.

{ To Non-Fellows,  
Price 5s.

JOURNAL  
OF THE  
ROYAL  
MICROSCOPICAL SOCIETY;

CONTAINING ITS TRANSACTIONS AND PROCEEDINGS,  
AND A SUMMARY OF CURRENT RESEARCHES RELATING TO  
ZOOLOGY AND BOTANY  
(principally Invertebrata and Cryptogamia),  
MICROSCOPY, &c.

*Edited by*

**FRANK CRISP, LL.B., B.A.,**

*One of the Secretaries of the Society*

*and a Vice-President and Treasurer of the Linnean Society of London;*

WITH THE ASSISTANCE OF THE PUBLICATION COMMITTEE AND

**A. W. BENNETT, M.A., B.Sc., F.L.S.,**  
*Lecturer on Botany at St. Thomas's Hospital,*

**F. JEFFREY BELL, M.A., F.Z.S.,**  
*Professor of Comparative Anatomy in King's College,*

**JOHN MAYALL, JUN., F.Z.S.,**

**R. G. HEBB, M.A., M.D. (Cantab.),**

AND

**J. ARTHUR THOMSON, M.A.,**

*Lecturer on Zoology in the School of Medicine, Edinburgh,*

FELLOWS OF THE SOCIETY.



WILLIAMS & NORGATE,  
LONDON AND EDINBURGH.

# CONTENTS.

TRANSACTIONS OF THE SOCIETY—

PAGE

VIII.—ADDITIONS TO THE KNOWLEDGE OF THE CARBONIFEROUS FORAMINIFERA. By the Rev. Walter Howchin, F.G.S. (Plates VIII. and IX.) .. .. .	533
---	-----

## SUMMARY OF CURRENT RESEARCHES.

### ZOOLOGY.

#### A. VERTEBRATA:—Embryology, Histology, and General.

##### a. Embryology.

WHITMAN, C. O.— <i>Kinetic Phenomena of the Egg during Maturation and Fecundation</i> .. .. .	546
NAGEL, W.— <i>Human Ovum</i> .. .. .	547
EBNER, V. v.— <i>Spermatogenesis of Mammals</i> .. .. .	547
ORB, H.— <i>Embryology of Lizard</i> .. .. .	548
SCHWINCK— <i>Gastrula of Amphibians</i> .. .. .	549
GOETTE, A.— <i>Development of Petromyzon fluviatilis</i> .. .. .	549
GUITEL, F.— <i>Egg-shell of Lepadogaster</i> .. .. .	550
CORIN, G., & E. BERARD— <i>Albuminoid Constituents of White of Egg</i> .. .. .	551
LIEBEHMANN, L.— <i>Embryochemical Investigations</i> .. .. .	551

##### b. Histology.

BOVERI, T.— <i>Cell-Studies</i> .. .. .	552
FLEMING (N.) <i>on the Cell</i> .. .. .	553
SCHOTTLÄNDER, T.— <i>Cell-division</i> .. .. .	554
WALDEYER, W.— <i>Karyokinesis and Heredity</i> .. .. .	554
EBREIRA, L.— <i>Cellular Statics</i> .. .. .	555
MICHEL, A.— <i>Fusion of Lymphatic Cells into Plasmodia</i> .. .. .	555
PANETH, J.— <i>Secreting Cells of Intestinal Epithelium</i> .. .. .	556
DAAE, H.— <i>Spinal Ganglion-cells</i> .. .. .	556
JAKIMOVITCH, J.— <i>Axis-cylinder and Nerve-cells</i> .. .. .	556

##### c. General.

BÜTSCHLI, O.— <i>Growth by Intussusception</i> .. .. .	557
SLUITER, C. P.— <i>Remarkable Case of Mutualism</i> .. .. .	557

#### B. INVERTEBRATA.

CÚNOT, M. L.— <i>Blood of Invertebrata</i> .. .. .	557
CHUN, C.— <i>Pelagic Animals at Great Depths and their Relations to the Surface Fauna</i> .. .. .	558
STEINER— <i>Physiology of Nervous System</i> .. .. .	559

##### Mollusca.

##### a. Cephalopoda.

BLAKE, J. F.— <i>Shell-growth in Cephalopoda</i> .. .. .	559
SABATIER, A.— <i>Spermatozoa of Eledone moschata</i> .. .. .	560

##### b. Pteropoda.

KALIDE, G.— <i>Musculature of Heteropoda and Pteropoda</i> .. .. .	560
--	-----

##### c. Gastropoda.

SMITH, A. A.— <i>Abnormal Growth in Haliotis</i> .. .. .	561
LACAZE-DUTHIERS, H. DE— <i>Testacella</i> .. .. .	562
FLÉISCHMANN, A.— <i>Absorption by Water</i> .. .. .	563

	PAGE
<b>δ. Lamellibranchiata.</b>	
PELSENEER, P.— <i>Lamellibranchiata without gills</i> .. .. .	564
BROCK, J.— <i>So-called Eyes of Tridacna and Occurrence of Pseudochlorophyll Cor- puscles in the Vascular System of Lamellibranchs</i> .. .. .	564
SHARP, B.— <i>Phylogeny of Lamellibranchs</i> .. .. .	565
HASELOFF, B.— <i>Crystalline Style</i> .. .. .	566
<b>Molluscoïda.</b>	
<b>β. Polyzoa.</b>	
KOROTNEFF, A.— <i>Spermatogenesis in Alcyonella</i> .. .. .	566
KRÄPELIN, K.— <i>Fresh-water Polyzoa</i> .. .. .	566
<b>Arthropoda.</b>	
BRUCE, A. T.— <i>Embryology of Insects and Arachnids</i> .. .. .	567
<b>α. Insecta.</b>	
GRABER, V.— <i>Polypody of Insect Embryos</i> .. .. .	568
RATH, O. VOM.— <i>Dermal Sensory Organ of Insects</i> .. .. .	569
SCHMID, E.— <i>Sub-aquatic Respiration</i> .. .. .	569
FIELDE, A. M.— <i>Dorsal Appendages</i> .. .. .	570
EMERY, C.— <i>So-called Digestive Stomach of some Ants</i> .. .. .	570
FOREL, A.— <i>Senses of Ants</i> .. .. .	571
VERSON, E.— <i>Parthenogenesis in Bombyx mori</i> .. .. .	571
PLATNER, G.— <i>Karyokinesis in Lepidoptera</i> .. .. .	571
URECH, F.— <i>Decrease of Weight in Winter Pupæ of Pontia brassicæ</i> .. .. .	572
VOELTSKOW, A.— <i>Development in Egg of Musca vomitoria</i> .. .. .	572
HENKING, H.— <i>Early Stages in Development of Egg of Fly</i> .. .. .	573
WILL, L.— <i>Development of Aphides</i> .. .. .	573
<b>γ. Arachnida.</b>	
PECKHAM, G. W. & E. G.— <i>Mental Powers of Spiders</i> .. .. .	575
SAINT-REMY, G.— <i>Brain of Phalangida</i> .. .. .	576
<b>δ. Prototracheata.</b>	
SEDGWICK, A.— <i>Monograph of the Genus Peripatus</i> .. .. .	576
SHELDON, L.— <i>Anatomy of Peripatus capensis and P. novæ Zealandiæ</i> .. .. .	577
<b>ε. Crustacea.</b>	
MACKAY, W. J.— <i>Intercozal Lobe of certain Crayfishes</i> .. .. .	577
HERRICK, F. H.— <i>Development of Alpheus</i> .. .. .	577
NORDQVIST, O.— <i>Moïna bathycolor and the greatest depths at which Cladocera are found</i> .. .. .	578
<b>Vermes.</b>	
<b>α. Annelida.</b>	
HASWELL, W. A.— <i>Embryology of Vermilia cæspitosa and Eupomatus elegans</i> .. .. .	578
BEDDARD, F. E.— <i>Reproductive Organs of Phreocyctes</i> .. .. .	579
BOURNE, G. C.— <i>Kleinenberg on Development of Lopadorhynchus</i> .. .. .	579
KÜKENTHAL, W.— <i>Experiments on Earthworms</i> .. .. .	580
KULAGIN, N.— <i>Russian Lumbricidæ</i> .. .. .	581
EISEN, G.— <i>New Annelid, Sutroa rostrata</i> .. .. .	582
STOKES, A. C.— <i>Two new Aquatic Worms from North America</i> .. .. .	582
<b>β. Nemathelminthes.</b>	
KULTSCHITZKY, N.— <i>Fertilization of Ascaris</i> .. .. .	583
LUKJANOW, S. M.— <i>Intestinal Epithelium of Ascaris</i> .. .. .	583
VEJDOFSKY, F.— <i>Studies on Gordiidsæ</i> .. .. .	583
CHATIN, J.— <i>Anguillulidæ of the Onion</i> .. .. .	585
BOS, RITZEMA.— <i>Tylenchus devastatrix</i> .. .. .	585
<b>γ. Platyhelminthes.</b>	
HALLEZ, P.— <i>Embryogeny of Fresh-water Dendrocoela</i> .. .. .	586
SALENSKY, W.— <i>Lateral Organs</i> .. .. .	587
FRIESCH, G.— <i>Bilharzia</i> .. .. .	588

	PAGE
5. Incertæ Sedis.	
SCHIMKEWITSCH, W.— <i>Balanoglossus Mereschkovskii</i> .. .. .	588
GREEFF, L. VON—'Challenger' <i>Myzostomida</i> .. .. .	590

### Echinodermata.

FLEISCHMANN, A.— <i>Development of Egg of Echinocardium cordatum</i> .. .. .	590
SARASIN, P. & F.— <i>Renal Organ of Echinoids</i> .. .. .	590
BELL, F. JEFFREY— <i>Remarkable Ophiurid from Brazil</i> .. .. .	591
LUDWIG, H.— <i>New and Old Holothurians</i> .. .. .	591

### Cœlenterata.

FEWKES, J. W.— <i>New Mode of Life among Medusæ</i> .. .. .	591
"    " <i>Medusæ from New England</i> .. .. .	592
"    " <i>New Physophore</i> .. .. .	592
FOWLER, G. H.— <i>New Pennatula from the Bahamas</i> .. .. .	593
FISCHER, P.— <i>Actinixæ of Coasts of France</i> .. .. .	593
BLOCHMANN, F., & C. HILGER— <i>Gonactinia prolifera</i> .. .. .	593
HAACKE, W.— <i>Nature of Polyparium</i> .. .. .	594

### Porifera.

DENDY, A.— <i>Comparative Anatomy of Sponges</i> .. .. .	594
MACMUNN, C. A.— <i>Chromatology of Sponges</i> .. .. .	595
TOISENT, E.— <i>Gemmules of Silicispongiæ</i> .. .. .	596
NOLL— <i>Silicoblasts</i> .. .. .	596
WELTNER, M.— <i>Survival of Spongillæ after Development of Swarm-larvæ</i> .. .. .	596
RIDLEY, S. O., & A. DENDY—'Challenger' <i>Sponges</i> .. .. .	597

### Protozoa.

BÜTSCHLI'S <i>Protozoa</i> .. .. .	597
GRUBER, A.— <i>Multinucleate Infusoria</i> .. .. .	597
MÖBIUS, K.— <i>Fulviculina ampulla</i> .. .. .	598
STOKES, A. C.— <i>Fresh-water Infusoria of the United States</i> .. .. .	598
BLANC, H.— <i>New Foraminifera</i> .. .. .	598
WIERZEJSKI, A.— <i>Psorospermium Haeckelii</i> .. .. .	598
GRASSI, B., & W. SCHEWIAKOFF— <i>Megastoma entericum</i> .. .. .	599

## BOTANY.

### A. GENERAL, including the Anatomy and Physiology of the Phanerogamia.

#### a. Anatomy.

##### (1) Cell-structure and Protoplasm.

STRASBURGER, E.— <i>Division of the Nucleus, Cell-division, and Impregnation</i> .. .. .	600
KORSICHEL, E.— <i>Relation between the Function and Position of the Nucleus</i> .. .. .	601
JANSE, J. M.— <i>Permeability of Protoplasm</i> .. .. .	601
FISCHER, A., J. WIESNER, & F. KRASSER— <i>Albuminous reaction of Cell-wall</i> .. .. .	602
AMBRONN, H.— <i>Pleochromism of coloured Cell-walls</i> .. .. .	602

##### (2) Other Cell-contents (including Secretions).

BACCARINI, P.— <i>Sphærocystals</i> .. .. .	603
TASSI, F.— <i>Nectar of Rhododendron</i> .. .. .	603
WAGNER, E.— <i>Tannin in the Crassulacææ</i> .. .. .	603
MÜNTZ, A.— <i>Occurrence of the Elements of Sugar of Milk in Plants</i> .. .. .	604
TSCHIRCH, A.— <i>Development of some Secretions and their Receptacles</i> .. .. .	604

##### (3) Structure of Tissues.

LEBLOIS, A.— <i>Secretory Canals and Secretory Reservoirs</i> .. .. .	604
MÜLLER, C.— <i>Secreting Canals of Umbelliferæ and Araliacææ contained in the Phloem</i> .. .. .	605
SCHÄFER, R. P. C.— <i>Influence of the Turgidity of the Epidermal Cells on the Stomata</i> .. .. .	605
WILLIAMSON, W. C.— <i>Anomalous Cells in the Interior of the Tissue of Fossil Plants</i> .. .. .	605
DOULIOT, H.— <i>Periderm of the Leguminosæ</i> .. .. .	606
AVETTA, C.— <i>Anomalies in the Structure of the Roots of Dicotyledons</i> .. .. .	606
DUMONT, A.— <i>Comparative Anatomy of Malvaceæ, Bombacææ, Tiliacææ, and Sterculiacææ</i> .. .. .	606

##### (4) Structure of Organs.

LIERAU, M.— <i>Roots of Aracææ</i> .. .. .	607
TAFEL, F. V.— <i>Mechanical Protection of Bulbs</i> .. .. .	607
SCOTT, D. H.— <i>Floating-roots of Sesbania aculeata</i> .. .. .	607
TIEGHEM, P. VAN, & P. PICHI— <i>Tubercles on the Roots of Leguminosæ</i> .. .. .	608

KLAUSCH, P.— <i>Leaves of Bupleurum</i> .. .. .	608
MÖBIUS, M.— <i>Anatomical Structure of the Leaves of Orchidææ</i> .. .. .	608
NOACH, F.— <i>Influence of Climate on the Cuticularization and Thickening of the Leaves of some Coniferæ</i> .. .. .	608
BEAUVISAGE— <i>Bracts of Cruciferæ</i> .. .. .	609
SCHULTZ, O.— <i>Physiological Anatomy of Stipules</i> .. .. .	609
DANGÉARD, P. A.— <i>Foliar Sheath of the Salicorniææ</i> .. .. .	609
WENT, F.— <i>Embryo-sac of Rosacææ</i> .. .. .	610
PETIT, L.— <i>Petiole of Dicotyledons</i> .. .. .	610
MANGIN, LOUIS— <i>Development of Flowers in the Bud</i> .. .. .	610
SCHUMANN, K.— <i>Morphology of the Flowers of Canna</i> .. .. .	611
CHODAT, R.— <i>Diagram of the Flower of Cruciferææ</i> .. .. .	611
BAILLON, H.— <i>Ovules of Grasses</i> .. .. .	611
BALFOUR, I. B.— <i>Replum in Cruciferææ</i> .. .. .	611
GARCIN, A. G.— <i>Fruit of Solanacææ</i> .. .. .	611
DINGLER, H.— <i>Motion of rotating Winged Fruits and Seeds</i> .. .. .	612

### β. Physiology.

#### (1) Reproduction and Germination.

SCHULZ, A.— <i>Pollination and Distribution of the Sexual Organs</i> .. .. .	612
BATESON, ANNA— <i>Effect of Cross-fertilization on Inconspicuous Flowers</i> .. .. .	612
JANCZEWSKI, E. DE— <i>Germination of Anemone apennina</i> .. .. .	613
HILDEBRAND, F.— <i>Germination of Oxalis rubella</i> .. .. .	613
MÜLLER, F.— <i>Germination of the Bicuiba</i> .. .. .	613
GREEN, J. R.— <i>Germination of the Tuber of the Jerusalem Artichoke</i> .. .. .	613

#### (2) Nutrition and Growth (including Movements of Fluids).

ARCANGELI, G.— <i>Influence of Light on the Growth of Leaves</i> .. .. .	614
LIEBSCHER, G.— <i>Supply of Food Constituents at Different Periods of the Growth of Plants</i> .. .. .	614

#### (3) Irritability.

GARDINER, W.— <i>Power of Contractility exhibited by the Protoplasm of certain Cells</i> .. .. .	614
WORTMANN, J.— <i>Movements of Irritation of Multicellular Organs</i> .. .. .	615
GODLEWSKI, E.— <i>Irritability of Growing Parts of Plants</i> .. .. .	615
OLIVER, F. W.— <i>Sensitive Labellum of Masdevallia muscosa</i> .. .. .	616

#### (4) Chemical Changes (including Respiration and Fermentation).

FRANK, B.— <i>Formation of Nitric Acid in Plants</i> .. .. .	616
--	-----

### γ. General.

VOLKENS' (G.) <i>Desert Flora</i> .. .. .	617
DETMER'S (W.) <i>Laboratory Course of Vegetable Physiology</i> .. .. .	617
VRIES, H. DE— <i>Isotonic Coefficient of Glycerin</i> .. .. .	617

## B. CRYPTOGAMIA.

### Cryptogamia Vascularia.

BOWER, F. O.— <i>Oophyte of Trichomanes</i> .. .. .	617
CAMPBELL, D. H.— <i>Development of Onoclea Struthiopteris Hoffm. (Struthiopteris germanica Willd.)</i> .. .. .	618
MÖHRING, W.— <i>Branching of the Frond of Ferns</i> .. .. .	619
BENZE, W.— <i>Leaves of Polypodiaceææ</i> .. .. .	619
DACCOMO, G.— <i>Aspidol from Aspidium Filix-mas</i> .. .. .	619
LECLERC DU SABLON— <i>Selaginella lepidophylla</i> .. .. .	620
SOLMS-LAUBACH'S <i>Introduction to Fossil Botany</i> .. .. .	620

### Muscineæ.

PHILIBERT— <i>Peristome of Mosses</i> .. .. .	620
RUSSOW, E.— <i>German Sphagnacæææ</i> .. .. .	621

### Lichenes.

WAINIO, E.— <i>Cladonia</i> .. .. .	621
SYDOW'S (P.) <i>Lichens of Germany</i> .. .. .	621

### Algæ.

WOODWORTH, W. M.— <i>Apical Cell of Fucus</i> .. .. .	621
SCHÜTT, F.— <i>Phycocerythrin</i> .. .. .	622
JOHNSON, T.— <i>Procaryp and Cystocaryp of Gracilaria</i> .. .. .	622
BIGELOW, R. P.— <i>Frond of Champia parvula</i> .. .. .	623
LAGERHEIM, G.— <i>Development of Hydrurus</i> .. .. .	623

	PAGE
ASKENASY, E.— <i>Development of Pediastrum</i> .. .. .	624
WEBER, VAN BOSSE— <i>Algæ parasitic on the Sloth</i> .. .. .	624
OVERTON, C. E.— <i>Conjugation of Spirogyra</i> .. .. .	625
LAGEHEIM, G.— <i>Uronema, a new genus of Chlorozoosporea</i> .. .. .	626
WILLE'S (N.) <i>Contributions to Algology</i> .. .. .	626
HANSGIRG'S (A.) <i>Alga-flora of Bohemia</i> .. .. .	626
HAUCK AND RICHTER'S <i>Phycotheca universalis</i> .. .. .	627
DE TONI AND LEVI'S <i>Venetian Chlorophyceæ</i> .. .. .	627
SCHÜTT, F.— <i>Chatoceros</i> .. .. .	627
RATTRAY, J.— <i>Varieties of Aulacodiscus</i> .. .. .	627

### Fungi.

ROLLAND, L.— <i>Blue Coloration of Fungi by Iodine</i> .. .. .	628
KARSTEN, H.— <i>Classification and Description of Fungi</i> .. .. .	628
VUILLEMIN, P.— <i>Biological Studies of Fungi</i> .. .. .	628
HECKEL, E.— <i>Formation of two fertile hymenia in Polyporus applanatus</i> .. .. .	629
FISCHER, E.— <i>Stretching of the Receptacle of the Phalloidei</i> .. .. .	629
MASSEE, G.— <i>Revision of the Genus Bovista</i> .. .. .	629
FRÉCHOU— <i>Formation of the Asei in Physalospora Bidwellii</i> .. .. .	629
DUFOUR, L.— <i>Development and Fructification of Trichocladium</i> .. .. .	630
SEYNES, J. DE— <i>Ceromyces and Fibrillaria</i> .. .. .	630
SACCARDO, P. A.— <i>New Genus of Sphæriaceous Pyrenomyces</i> .. .. .	630
BERLESE, A. N.— <i>New Genus Peltotharia</i> .. .. .	630
BOUDIER— <i>New Mucedineæ</i> .. .. .	631
BERLESE, A. N.— <i>Clathrospora and Pyrenophora</i> .. .. .	631
COSTANTIN, J.— <i>New Papulaspora</i> .. .. .	631
MAGNUS, P.— <i>Schinzia</i> .. .. .	631
ROUMEGUÈRE, C.— <i>Fungus Parasitic on the Plane</i> .. .. .	631
SANFORD, E.— <i>Anatomy of the Common Cedar-apple</i> .. .. .	631

### Protophyta.

GOMONT, M.— <i>Cellular Envelope of the Filamentous Nostocaceæ</i> .. .. .	632
BORZI, A.— <i>Development of Mischococcus confervicola</i> .. .. .	632
LAGEHEIM, G.— <i>Stichococcus bacillaris</i> .. .. .	632
DE TONI, G. B.— <i>Remarkable Flos-aquæ</i> .. .. .	633
PERRONCITO, E. & VARALDA, L.— <i>Composition of "Muffe"</i> .. .. .	633
ARCANGELI, G.— <i>Saccharomyces minor</i> .. .. .	633
WASSERZUG, E.— <i>Spores of the Ferments</i> .. .. .	633
TOMASCHEK, A.— <i>Symbiosis of Baeteria with Gloeocapsa polyderrmatica</i> .. .. .	634
ARLOING, S.— <i>Presence of a Phlogogenous matter in the Cultures of certain Microbes</i> .. .. .	634
GALTIER— <i>Chromo-aromatic Microbe</i> .. .. .	634
HAUSER, G.— <i>Sarcina of the Lungs</i> .. .. .	634
BORDONI-UFFREDUZZI, G.— <i>New Pathogenic Microphyte in Men and Animals</i> .. .. .	634
SPELLMANN & HAUSHALTER— <i>Dissemination of Bacillus by Flies</i> .. .. .	635

## MICROSCOPY.

### a. Instruments, Accessories, &c.

#### (1) Stands.

ZEISS'S (C.) <i>Ila. Microscope</i> (Fig. 96) .. .. .	637
BABUCHIN'S <i>Microscope</i> (Fig. 97) .. .. .	637
GALILEO'S <i>Microscopes</i> (Figs. 98 and 99) .. .. .	639
JOBLOT'S <i>Microscope</i> (Fig. 100) .. .. .	640
HENSOLDT'S (M.) <i>Reading Microscopes</i> (Figs. 101 and 102) .. .. .	640

#### (2) Eye-pieces and Objectives.

VOGEL, H. W.— <i>Hartauch's new Objective</i> .. .. .	646
---	-----

#### (3) Illuminating and other Apparatus.

HILGENDORF'S <i>Auzanograph</i> (Fig. 103) .. .. .	646
CHAFFMAN, F. T.— <i>Slide for observing Soap-bubble Films</i> (Fig. 104) .. .. .	647
SCHÄPFER'S <i>Hot-water Circulation Stage and Swift's Regulator</i> (Fig. 105) .. .. .	649
BERTRAND'S <i>Refractometer</i> .. .. .	649

#### (4) Photomicrography.

LEITZ'S <i>small Photo-micrographic Apparatus</i> (Fig. 106) .. .. .	650
PLÖSSL'S <i>Focusing Arrangement</i> (Fig. 107) .. .. .	651
CAPRANICA, S.— <i>Instantaneous Photomicrography</i> .. .. .	651

#### (5) Microscopical Optics and Manipulation.

(6) Miscellaneous.		PAGE
COX, C. F.— <i>American Microscopes</i> .. .. .		652
DEATH of Mr. Webb .. .. .		654
<b>β. Technique.</b>		
(1) Collecting Objects, including Culture Processes.		
JACOBI, E.— <i>Preparation of Nutritive Media</i> .. .. .		655
FREUDENREICH, E.— <i>Preparing Agar-agar</i> .. .. .		656
RASKIN, M.— <i>Milk-peptone-gelatin for cultivating Pathogenic Micro-organisms</i> .. .. .		656
DIAKONOW, N. W.— <i>Vessel for the Culture of Low Organisms (Fig. 108)</i> .. .. .		657
(2) Preparing Objects.		
MISCHTOLD, A.— <i>Preservation of Parts and Organs of Animals</i> .. .. .		658
THANHOFFER, L. v.— <i>Two new Methods for preparing Nerve-cells</i> .. .. .		658
BRONDI, D.— <i>New Method for the Microscopical Study of the Blood</i> .. .. .		659
RANVIER, L.— <i>Preparation and Staining of the Spinal Cord</i> .. .. .		660
CHIARUGI, G.— <i>Demonstrating the Canalicular Prolongations of Bone-corpuscles</i> .. .. .		661
PALADINO, G.— <i>Preparing Mammalian Ovaries</i> .. .. .		662
JOURDAN, E.— <i>Preparing and Staining Annelida</i> .. .. .		662
FRAIPONT, J.— <i>Preparing Polygordius</i> .. .. .		662
ZACHARIAS' (O.) <i>Method of Preparing Eggs of Ascaris megaloccephala</i> .. .. .		663
BOYER'S (T.) <i>Method of Preparing the Eggs of Ascaris megaloccephala</i> .. .. .		664
KELLER, C. C.— <i>Isolating Foraminifera</i> .. .. .		664
BRANDT, K.— <i>Preparing Sphærozoa</i> .. .. .		665
KING, J. D.— <i>Preparation and Mounting of Ferns</i> .. .. .		665
LAGERHEIM, G.— <i>Application of Lactic Acid to the Examination of Algae</i> .. .. .		666
TEMPÈRE'S (J.) <i>Preparations of Diatoms</i> .. .. .		667
(3) Cutting, including Imbedding.		
DUVAL, M.— <i>Collodion for Imbedding in Embryology</i> .. .. .		667
SCHWABE'S <i>Sliding Microtome (Fig. 109)</i> .. .. .		668
ZWAARDEMAKER, H.— <i>Accessory to the Cambridge Rocking Microtome (Figs. 110 and 111)</i> .. .. .		666
BUMPUS, H. C.— <i>Inexpensive Section-smoother (Fig. 112)</i> .. .. .		670
APÁTHY, J.— <i>Preparing Long Series of Sections with Celloidin</i> .. .. .		670
PROPER <i>Thickness of Microscopical Sections</i> .. .. .		671
NEISSER, A.— <i>Preparing Sections from Test-tube Cultivations</i> .. .. .		671
(4) Staining and Injecting.		
GRAY, W. M.— <i>Double-staining of Nucleated Blood-corpuscles</i> .. .. .		673
KÜHNE, W.— <i>Staining Nerve-endings with Gold Chloride</i> .. .. .		673
BOCCARDI, G.— <i>Staining-Nerve-endings with Gold Chloride</i> .. .. .		674
SCHIEFFERDECKER, P.— <i>Weigert's Hæmatoxylin Method as applied to other than Nervous Tissues</i> .. .. .		674
BIZZAZERO, G., & G. VASSALE— <i>Staining Mitoses</i> .. .. .		674
ZIMMERMAN, A.— <i>Staining Leucoplasts, Protein-granules, Bordered Pit Membranes, and Woody Tissue</i> .. .. .		675
WEIGERT, C.— <i>New Method for Staining Fibrin and Micro-organisms</i> .. .. .		675
PLATNER, G.— <i>New Nuclear Stain and Note on Fixation</i> .. .. .		675
LEWIN, A.— <i>Baumgarten's Method of Triple-staining</i> .. .. .		676
BABES, V.— <i>Anilin-oil Safranin Solution</i> .. .. .		676
GRIESBACH, H.— <i>Metanil-yellow</i> .. .. .		677
BRAUNS, R.— <i>Simple Method for clearing Methylene Iodide</i> .. .. .		677
BORDEN, W. C.— <i>Carmine Injections</i> .. .. .		677
ROBIN'S, LACAZE-DUTHIERS', & FARABEUF'S <i>Injecting Syringes (Figs. 113-115)</i> .. .. .		678
FOL, H.— <i>Collin's Automatic Cannula-holder (Fig. 116)</i> .. .. .		680
(5) Mounting, including Slides, Preservative Fluids, &c.		
BRAMWELL, BYROM— <i>Half-clearing method of preparing Nerve Sections</i> .. .. .		680
POLI, A.— <i>Adaptation of Kaiser's gelatin for arranging microscopic preparations in rows</i> .. .. .		680
KELLER, C. C.— <i>Purification of Tolu Balsam for Microscopical Purposes</i> .. .. .		681
MALASSEZ, L.— <i>Hot Plate Apparatus (Figs. 117 and 118)</i> .. .. .		681
(6) Miscellaneous.		
BUCHNER, H., T. LONGARD, & G. RIEDLIN— <i>Method of Calculating the rapidity of Bacterial Increase (Fig. 119)</i> .. .. .		682
HANSEN, E. C.— <i>Analysis of Water used for Brewing as regards Micro-organisms</i> .. .. .		685
PROCEEDINGS OF THE SOCIETY .. .. .		687

I.—APERTURE TABLE.

Numerical Aperture. ( $n \sin u = a$ )	Corresponding Angle ( $2u$ ) for			Limit of Resolving Power, in Lines to an Inch.			Illuminating Power. ( $a^2$ .)	Penetrating Power. ( $\frac{1}{a}$ )
	Air ( $n = 1.00$ .)	Water ( $n = 1.33$ .)	Homogeneous Immersion ( $n = 1.52$ .)	White Light. ( $\lambda = 0.5269 \mu$ , Line E.)	Monochromatic (Blue) Light. ( $\lambda = 0.4861 \mu$ , Line F.)	Photography. ( $\lambda = 0.4000 \mu$ , near Line A.)		
1.52	..	..	180° 0'	146,543	158,845	193,037	2.310	.658
1.51	..	..	166° 51'	145,579	157,800	191,767	2.280	.662
1.50	..	..	161° 23'	144,615	156,755	190,497	2.250	.667
1.49	..	..	157° 12'	143,651	155,710	189,227	2.220	.671
1.48	..	..	153° 39'	142,687	154,665	187,957	2.190	.676
1.47	..	..	150° 32'	141,723	153,620	186,687	2.161	.680
1.46	..	..	147° 42'	140,759	152,575	185,417	2.132	.685
1.45	..	..	145° 6'	139,795	151,530	184,147	2.103	.690
1.44	..	..	142° 39'	138,830	150,485	182,877	2.074	.694
1.43	..	..	140° 22'	137,866	149,440	181,607	2.045	.699
1.42	..	..	138° 12'	136,902	148,395	180,337	2.016	.704
1.41	..	..	136° 8'	135,938	147,350	179,067	1.988	.709
1.40	..	..	134° 10'	134,974	146,305	177,797	1.960	.714
1.39	..	..	132° 16'	134,010	145,260	176,527	1.932	.719
1.38	..	..	130° 26'	133,046	144,215	175,257	1.904	.725
1.37	..	..	128° 40'	132,082	143,170	173,987	1.877	.739
1.36	..	..	126° 58'	131,118	142,125	172,717	1.850	.735
1.35	..	..	125° 18'	130,154	141,080	171,447	1.823	.746
1.34	..	..	123° 40'	129,189	140,035	170,177	1.796	.741
1.33	..	180° 0'	122° 6'	128,225	138,989	168,907	1.769	.752
1.32	..	165° 56'	120° 33'	127,261	137,944	167,637	1.742	.758
1.31	..	160° 6'	119° 3'	126,297	136,899	166,367	1.716	.763
1.30	..	155° 38'	117° 35'	125,333	135,854	165,097	1.690	.769
1.29	..	151° 50'	116° 8'	124,369	134,809	163,827	1.664	.775
1.28	..	148° 42'	114° 44'	123,405	133,764	162,557	1.638	.781
1.27	..	145° 27'	113° 21'	122,441	132,719	161,287	1.613	.787
1.26	..	142° 39'	111° 59'	121,477	131,674	160,017	1.588	.794
1.25	..	140° 3'	110° 39'	120,513	130,629	158,747	1.563	.800
1.24	..	137° 36'	109° 20'	119,548	129,584	157,477	1.538	.806
1.23	..	135° 17'	108° 2'	118,584	128,539	156,207	1.513	.813
1.22	..	133° 4'	106° 45'	117,620	127,494	154,937	1.488	.820
1.21	..	130° 57'	105° 30'	116,656	126,449	153,668	1.464	.826
1.20	..	128° 55'	104° 15'	115,692	125,404	152,397	1.440	.833
1.19	..	126° 58'	103° 2'	114,728	124,359	151,128	1.416	.840
1.18	..	125° 3'	101° 50'	113,764	123,314	149,857	1.392	.847
1.17	..	123° 13'	100° 38'	112,799	122,269	148,588	1.369	.855
1.16	..	121° 26'	99° 29'	111,835	121,224	147,317	1.346	.862
1.15	..	119° 41'	98° 20'	110,872	120,179	146,048	1.323	.870
1.14	..	118° 0'	97° 11'	109,907	119,134	144,777	1.300	.877
1.13	..	116° 20'	96° 2'	108,943	118,089	143,508	1.277	.885
1.12	..	114° 44'	94° 55'	107,979	117,044	142,237	1.254	.893
1.11	..	113° 9'	93° 47'	107,015	115,999	140,968	1.232	.901
1.10	..	111° 36'	92° 43'	106,051	114,954	139,698	1.210	.909
1.09	..	110° 5'	91° 38'	105,087	113,909	138,428	1.188	.917
1.08	..	108° 36'	90° 34'	104,123	112,864	137,158	1.166	.926
1.07	..	107° 8'	89° 30'	103,159	111,819	135,888	1.145	.935
1.06	..	105° 42'	88° 27'	102,195	110,774	134,618	1.124	.943
1.05	..	104° 16'	87° 24'	101,231	109,729	133,348	1.103	.952
1.04	..	102° 53'	86° 21'	100,266	108,684	132,078	1.082	.962
1.03	..	101° 30'	85° 19'	99,302	107,639	130,808	1.061	.971
1.02	..	100° 10'	84° 18'	98,338	106,593	129,538	1.040	.980
1.01	..	98° 50'	83° 17'	97,374	105,548	128,268	1.020	.990
1.00	180° 0'	97° 31'	82° 17'	96,410	104,503	126,998	1.000	1.000
0.99	163° 48'	96° 12'	81° 17'	95,446	103,458	125,728	.980	1.010
0.98	157° 2'	94° 56'	80° 17'	94,482	102,413	124,458	.960	1.020
0.97	151° 52'	93° 40'	79° 18'	93,518	101,368	123,188	.941	1.031
0.96	147° 29'	92° 24'	78° 20'	92,554	100,323	121,918	.922	1.042
0.95	143° 36'	91° 10'	77° 22'	91,590	99,278	120,648	.903	1.053
0.94	140° 6'	89° 56'	76° 24'	90,625	98,233	119,378	.884	1.064
0.93	136° 52'	88° 44'	75° 27'	89,661	97,188	118,108	.865	1.075
0.92	133° 51'	87° 32'	74° 30'	88,697	96,143	116,838	.846	1.087
0.91	131° 0'	86° 20'	73° 33'	87,733	95,098	115,568	.828	1.099
0.90	128° 19'	85° 10'	72° 36'	86,769	94,053	114,298	.810	1.111
0.89	125° 45'	84° 0'	71° 40'	85,805	93,008	113,028	.792	1.124
0.88	123° 17'	82° 51'	70° 44'	84,841	91,963	111,758	.774	1.136

APERTURE TABLE—continued.

Numerical Aperture. ( $n \sin u = a.$ )	Corresponding Angle (2 $u$ ) for			Limit of Resolving Power, in Lines to an Inch.			Illuminating Power. ( $a^2$ .)	Penetrating Power. ( $\frac{1}{a}$ )
	Air ( $n = 1.00$ .)	Water ( $n = 1.33$ .)	Homogeneous Immersion ( $n = 1.52$ .)	White Light. ( $\lambda = 0.5269 \mu$ , Line E.)	Monochromatic (Blue) Light. ( $\lambda = 0.4861 \mu$ , Line F.)	Photography. ( $\lambda = 0.4000 \mu$ , near Line h.)		
0.87	120° 55'	81° 42'	69° 49'	83,877	90,918	110,488	.757	1.149
0.86	118° 38'	80° 34'	68° 54'	82,913	89,873	109,218	.740	1.163
0.85	116° 25'	79° 37'	68° 0'	81,949	88,828	107,948	.723	1.176
0.84	114° 17'	78° 20'	67° 6'	80,984	87,783	106,678	.706	1.190
0.83	112° 12'	77° 14'	66° 12'	80,020	86,738	105,408	.689	1.205
0.82	110° 10'	76° 8'	65° 18'	79,056	85,693	104,138	.672	1.220
0.81	108° 10'	75° 3'	64° 24'	78,092	84,648	102,868	.656	1.235
0.80	106° 16'	73° 58'	63° 31'	77,128	83,603	101,598	.640	1.250
0.79	104° 22'	72° 53'	62° 38'	76,164	82,558	100,328	.624	1.266
0.78	102° 31'	71° 49'	61° 45'	75,200	81,513	99,058	.608	1.282
0.77	100° 42'	70° 45'	60° 52'	74,236	80,468	97,788	.593	1.299
0.76	98° 56'	69° 42'	60° 0'	73,272	79,423	96,518	.578	1.316
0.75	97° 11'	68° 40'	59° 8'	72,308	78,378	95,248	.563	1.333
0.74	95° 28'	67° 37'	58° 16'	71,343	77,333	93,979	.548	1.351
0.73	93° 46'	66° 34'	57° 24'	70,379	76,288	92,709	.533	1.370
0.72	92° 6'	65° 32'	56° 32'	69,415	75,242	91,439	.518	1.389
0.71	90° 28'	64° 32'	55° 41'	68,451	74,197	90,169	.504	1.408
0.70	88° 51'	63° 31'	54° 50'	67,487	73,152	88,899	.490	1.429
0.69	87° 16'	62° 30'	53° 59'	66,523	72,107	87,629	.476	1.449
0.68	85° 41'	61° 30'	53° 9'	65,559	71,062	86,359	.462	1.471
0.67	84° 8'	60° 30'	52° 18'	64,595	70,017	85,089	.449	1.493
0.66	82° 36'	59° 30'	51° 28'	63,631	68,972	83,819	.436	1.515
0.65	81° 6'	58° 30'	50° 38'	62,667	67,927	82,549	.423	1.538
0.64	79° 36'	57° 31'	49° 48'	61,702	66,882	81,279	.410	1.562
0.63	78° 6'	56° 32'	48° 58'	60,738	65,837	80,009	.397	1.587
0.62	76° 38'	55° 34'	48° 9'	59,774	64,792	78,739	.384	1.613
0.61	75° 10'	54° 36'	47° 19'	58,810	63,747	77,469	.372	1.639
0.60	73° 44'	53° 38'	46° 30'	57,846	62,702	76,199	.360	1.667
0.59	72° 18'	52° 40'	45° 40'	56,881	61,657	74,929	.348	1.695
0.58	70° 54'	51° 42'	44° 51'	55,918	60,612	73,659	.336	1.724
0.57	69° 30'	50° 45'	44° 2'	54,954	59,567	72,389	.325	1.754
0.56	68° 6'	49° 48'	43° 14'	53,990	58,522	71,119	.314	1.786
0.55	66° 44'	49° 51'	42° 25'	53,026	57,477	69,849	.303	1.818
0.54	65° 22'	47° 54'	41° 37'	52,061	56,432	68,579	.292	1.852
0.53	64° 0'	46° 58'	40° 48'	51,097	55,387	67,309	.281	1.887
0.52	62° 40'	46° 2'	40° 0'	50,133	54,342	66,039	.270	1.923
0.51	61° 20'	45° 6'	39° 12'	49,169	53,297	64,769	.260	1.961
0.50	60° 0'	44° 10'	38° 24'	48,205	52,252	63,499	.250	2.000
0.48	57° 22'	42° 18'	36° 49'	46,277	50,162	60,959	.230	2.083
0.46	54° 47'	40° 28'	35° 15'	44,349	48,072	58,419	.212	2.174
0.45	53° 30'	39° 33'	34° 27'	43,385	47,026	57,149	.203	2.222
0.44	52° 13'	38° 38'	33° 40'	42,420	45,981	55,879	.194	2.273
0.42	49° 40'	36° 49'	32° 5'	40,492	43,891	53,339	.176	2.381
0.40	47° 9'	35° 0'	30° 31'	38,564	41,801	50,799	.160	2.500
0.38	44° 40'	33° 12'	28° 57'	36,636	39,711	48,259	.144	2.632
0.36	42° 12'	31° 24'	27° 24'	34,708	37,621	45,719	.130	2.778
0.35	40° 58'	30° 30'	26° 38'	33,744	36,576	44,449	.123	2.857
0.34	39° 44'	29° 37'	25° 51'	32,779	35,531	43,179	.116	2.941
0.32	37° 20'	27° 51'	24° 18'	30,851	33,441	40,639	.102	3.125
0.30	34° 56'	26° 4'	22° 46'	28,923	31,351	38,099	.090	3.333
0.28	32° 32'	24° 18'	21° 14'	26,995	29,261	35,559	.078	3.571
0.26	30° 10'	22° 33'	19° 42'	25,067	27,171	33,019	.068	3.846
0.25	28° 58'	21° 40'	18° 56'	24,103	26,126	31,749	.063	4.000
0.24	27° 46'	20° 48'	18° 10'	23,138	25,081	30,479	.058	4.167
0.22	25° 26'	19° 2'	16° 38'	21,210	22,991	27,940	.048	4.545
0.20	23° 4'	17° 18'	15° 7'	19,282	20,901	25,400	.040	5.000
0.18	20° 44'	15° 34'	13° 36'	17,354	18,811	22,860	.032	5.555
0.16	18° 24'	13° 50'	12° 5'	15,426	16,721	20,320	.026	6.250
0.15	17° 14'	12° 58'	11° 19'	14,462	15,676	19,050	.023	6.667
0.14	16° 5'	12° 6'	10° 34'	13,498	14,630	17,780	.020	7.143
0.12	13° 47'	10° 22'	9° 4'	11,570	12,540	15,240	.014	8.333
0.10	11° 29'	8° 38'	7° 34'	9,641	10,450	12,700	.010	10.000
0.08	9° 11'	6° 54'	6° 3'	7,713	8,360	10,160	.006	12.500
0.06	6° 53'	5° 10'	4° 32'	5,785	6,270	7,620	.004	16.667
0.05	5° 44'	4° 18'	3° 46'	4,821	5,225	6,350	.003	20.000

**GREATLY REDUCED PRICES**  
OF  
**OBJECT-GLASSES MANUFACTURED BY**  
**R. & J. BECK,**  
68, CORNHILL, LONDON, E.C.

**PRICES OF BEST ACHROMATIC OBJECT-GLASSES.**

No.	Focal length.	Angle of aperture, about	Price.	Linear magnifying-power, with 10-inch body-tube and eye-pieces.				
				No. 1.	No. 2.	No. 3.	No. 4.	No. 5.
100	4 inches .. ..	9	£ 1 10 0	10	16	30	40	50
101	3 inches .. ..	7	1 10 0	15	24	45	60	75
102	3 inches .. ..	12	2 10 0					
103	2 inches .. ..	10	1 10 0	22	35	67	90	112
104	2 inches .. ..	17	2 10 0					
105	1½ inch .. ..	23	2 10 0	30	48	90	120	150
106	1½ inch .. ..	25	2 0 0					
107	1 inch .. ..	32	2 10 0	70	112	210	280	350
108	1 inch .. ..	45	2 10 0					
109	¾ inch .. ..	65	4 0 0	100	160	300	400	500
110	⅔ inch .. ..	95	5 0 0	125	200	375	500	625
111	⅕ inch .. ..	75	3 10 0	150	240	450	600	750
112	⅙ inch .. ..	120	4 10 0	200	320	600	800	1000
113	⅙ inch .. ..	130	5 0 0	250	400	750	1000	1250
114	⅙ inch .. ..	180	5 5 0	300	640	1200	1600	2000
115	⅙ inch .. ..	180	8 0 0	500	800	1500	2000	2500
116	⅙ inch .. ..	180	10 0 0	750	1200	2250	3000	3750
117	⅙ inch .. ..	160	20 0 0	1000	1600	3000	4000	5000
				2000	3200	6000	8000	10,000

**ECONOMIC ACHROMATIC OBJECT-GLASSES,**

APPLICABLE TO ALL INSTRUMENTS MADE WITH THE UNIVERSAL SCREW.

No.	Focal length.	Angle of aperture, about	Price.	MAGNIFYING-POWER, with 6-inch body and eye-pieces.		
				No. 1.	No. 2.	No. 3.
150	3 inches .. ..	6	£ 1 0 0	12	15	27
151	2 inches .. ..	8	1 0 0	18	23	41
152	1 inch .. ..	12	1 5 0	46	61	106
153	¾ inch .. ..	38	1 5 0	90	116	205
154	½ inch .. ..	80	1 5 0	170	220	415
155	⅓ inch .. ..	110	2 5 0	250	330	630
156	¼ inch .. ..	110	3 10 0	350	450	800
157	⅙ inch .. ..	120	6 0 0	654	844	1500

Revised Catalogue sent on application to

**R. & J. BECK, 68, Cornhill.**



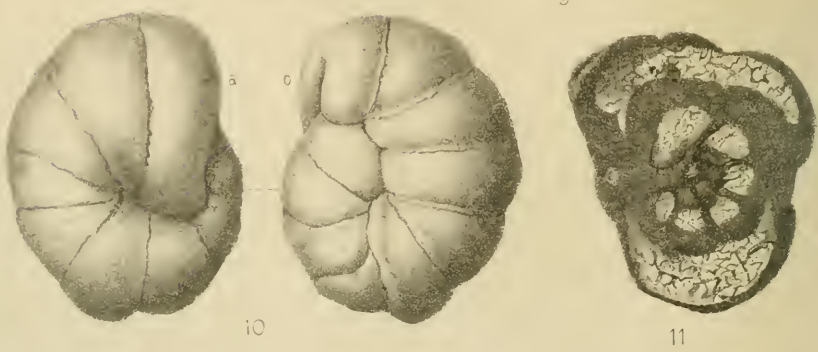
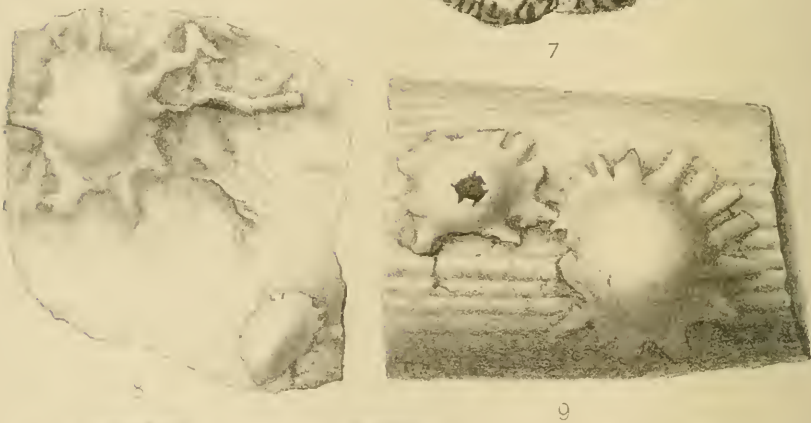



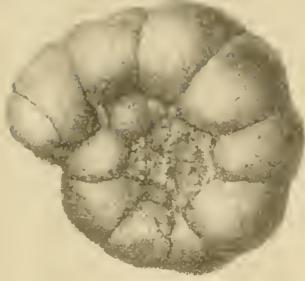

12



b

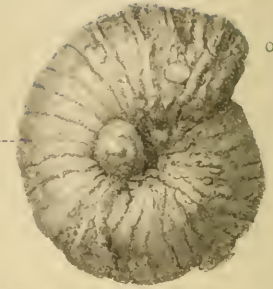

a

13



14



15



16

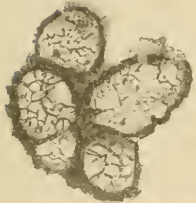

18

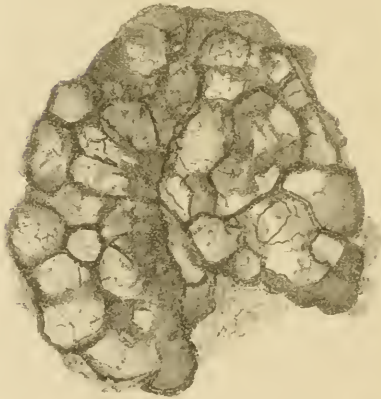

20



17

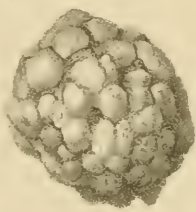

19



a

21

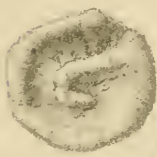

21b



22



25

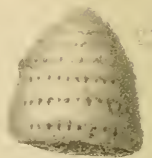

23a

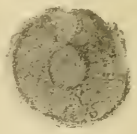

24

# JOURNAL

OF THE

## ROYAL MICROSCOPICAL SOCIETY.

AUGUST 1888.

### TRANSACTIONS OF THE SOCIETY.

#### VIII.—Additions to the Knowledge of the Carboniferous Foraminifera.

By the Rev. WALTER HOWCHIN, F.G.S.

(Read 13th June, 1888.)

PLATES VIII. AND IX.

RESEARCHES in relation to the Carboniferous Foraminifera of the North of England were begun by the author in 1873, and some of the earlier

#### EXPLANATION OF PLATES.

##### PLATE VIII.

- Figs. 1, 2.—*Hyperammina elongata*, var. *clavata*, nov. .. .. × 60 diam.  
 " 3.————— *vagans*, Brady .. .. × 50 diam.  
 " 4.—*Placopsilina cenomana*, d'Orbigny .. .. × 35 diam.  
 " 5.—*Lituola rotundata*, sp. nov. .. .. × 50 diam.  
 " 6.—————, transverse section .. .. × 50 diam.  
 " 7.—*Lituola Bonniciana*, Brady .. .. × 55 diam.  
 Vertical section showing the coarse perforation of the test.  
 " 8, 9.—*Webbina fimbriata*, sp. nov. .. .. × 100 diam.  
 " 10.—*Endothyra circumplicata*, sp. nov. .. .. × 40 diam.  
*a, b*, the two lateral aspects of the test.  
 " 11.—————, transparent section showing the septal plane of the last convolution at right angles to that of the earlier whorls .. .. × 45 diam.

##### PLATE IX.

- " 12.—*Endothyra conspicua*, sp. nov. .. .. × 35 diam.  
 " 13.————— *radiata*, var. *Tateana*, nov. .. .. × 40 diam.  
*a*, lateral aspect; *b*, peripheral aspect.  
 " 14.—————, .. .. × 40 diam.  
 Weathered specimen exhibiting the double septal partitions.  
 " 15.—————, transparent section .. .. × 45 diam.  
 " 16.—*Webbina irregularis*, d'Orbigny, attached specimen .. .. × 35 diam.  
 " 17.—————, inferior surface of two detached chambers .. .. × 35 diam.  
 " 18.—*Archælagena Howchiniana*, Brady, sp. .. .. × 45 diam.  
 Transparent section through a group showing interseptal communication.  
 " 19.—*Stacheia moriformis*, sp. nov. .. .. × 35 diam.  
 " 20.—————, transparent section .. .. × 60 diam.  
 " 21.—*Nodosaria (D.) farcimen*, Soldani sp. .. .. × 60 diam.  
*a*, lateral aspect; *b*, apertural end.  
 " 22.—*Patellina Bradyana*, sp. nov. .. .. × 65 diam.  
 Lateral aspect of a tall specimen.  
 " 23.—————, *a*, lateral aspect of a short specimen .. .. × 55 diam.  
*b*, inferior face of another shell .. .. × 65 diam.  
 " 24.—————, transverse section .. .. × 55 diam.  
 " 25.—————, longitudinal section .. .. × 55 diam.

1888.

2 P

results were included and acknowledged by Mr. H. B. Brady, F.R.S., in his 'Monograph of the Carboniferous and Permian Foraminifera,' published in the Palæontographical Society's volume for 1876. The publication of a general treatise on the subject, by so competent an authority, offered great facilities for workers in this interesting although somewhat difficult palæontological study. In 1876 the author of the present paper began a systematic investigation of the microzoic beds of Carboniferous age over an extended area of the North of England. The country thus geologically examined may be roughly stated as extending from the Wansbeck to the Wear, in a north and south direction, and from a line a little east of Corbridge, on the east, to Greenhead, on the west. The vertical range of the geological section concerned extends from the highest calcareous bed of the district down to the "P" Limestone of the Ordnance Geological Survey map. Within the limits of the vertical section, 30 distinct calcareous beds are included and separately denominated, and in their examination for Foraminifera, results have been tabulated from 83 localities and 242 separate washings. Although every available argillo-calcareous horizon in this series was placed under examination, only five samples throughout the entire vertical range were found to yield no trace of Foraminifera. The district, as defined above, is generally rich in microzoa, whilst some geological horizons are extraordinarily so. The labour of gathering, preparing, and examining so much material, together with manipulating many hundreds of transparent sections necessary to determine doubtful forms, can only be appreciated by those who have had experience in working out these or similar minute palæozoic organisms.

The object of the present communication is to place on record some of the more interesting forms, either new to science or previously unobserved in rocks of palæozoic age, met with during my investigations. I may add that in addition to the species enumerated in the following pages, there are a number of other organisms, which I have some ground for believing to be foraminiferal; but as the evidence of their affinity is scarcely sufficient to carry conviction to those less accustomed to handle the obscure and often much altered fossil microzoa of these palæozoic limestones, it appears safest for the present to leave them undescribed.

I must express my great indebtedness to Mr. H. B. Brady, not only for many valuable hints and the trouble he has taken in the preliminaries of publication, but also in seeing this paper through the press, a service all the more valuable in that it was cheerfully rendered and that without it the difficulties of publishing these notes at so great a distance, I fear, would have been insuperable. Mr. Rogers, of Adelaide, has also placed me under great obligation in drawing the objects, in the first instance, from nature, a work in which he has shown great patience and accuracy.

## Family ASTRORHIZIDÆ.

## Sub-family Rhabdammininæ.

## Genus HYPERAMMINA, Brady.

*Hyperammina elongata*, var. *clavatula*, nov. Plate VIII. figs. 1, 2.

Test free, clavate in form; primordial end inflated, rounded and closed; tubular extension straight or only slightly curved, of uniform diameter throughout, and short; sometimes marked externally by slightly depressed transverse lines. Texture finely arenaceous. Walls thin, smooth on both exterior and interior surfaces. Aperture, the open end of tubular extension. Short diameter of tube  $1/130$  in. Length  $1/30$  in.

The discovery of *Hyperammina* in the Jurassic rocks of Switzerland, by Dr. Hæusler, and, almost concurrently, that of a vermiculate fossil in the Silurian of Scotland (*Girvanella*) by Messrs. Nicholson and Etheridge, which Mr. H. B. Brady thinks more than probable may belong to the same genus, indicate a high probability that some representatives of this very simple form might occur in the rich microzoic beds of the Carboniferous Limestone. The organism now described seems, in all respects, very characteristic, and comes so near the smooth examples of *H. elongata*, Br., that it can hardly be specifically distinguished from that form. It differs, however, in its minute dimensions, the proportionately larger size of its primordial chamber, and its shorter contour. With regard to the last mentioned feature it is just possible that the Carboniferous examples fail to show the entire length of the tube. Its minute size and delicate proportions render it very liable to breakage in the mechanical operations of cleaning the material; but, on the other hand, I have not detected a single fragment in the material searched that would be recognized as a fractured portion of the organism.

*Distribution.*—It was noted in seven samples of material, embracing the Great Limestone and the "D," "H," "I," and "J" Limestones of the Cowburn and Tipalt districts. It is more or less scarce except in the overlying shale of the Great Limestone at Clowes Gill. It maintains a remarkable uniformity of character throughout the geological section, and cannot well be mistaken for any other form.

*Hyperammina vagans*, Brady. Plate VIII. fig. 3.

An adherent vermiform test of arenaceous texture; consisting of a primordial chamber (not clearly defined in the Carboniferous specimens) and a tubular extension, the latter disposed either in more or less closely set parallel lines or growing wildly and irregularly; always either attached to the surface of some foreign body or forming of itself acervuline masses, the diameter of the tube being about  $1/800$  in.

It has not been an easy matter to assign a place to this minute and very irregular organism. It occurs in confused masses, and it is

rarely that a specimen can be found showing the primordial cell, the latter having been generally obscured by the subsequent growth of the tubular portion.

Prof. Nicholson and Mr. R. Etheridge, jun., in their monograph of "The Silurian Fossils of the Girvan District," have described a minute vermiform object [*Girvanella problematica*] which appears closely to resemble the above. With the hope that Mr. Etheridge would be able to determine their identity, or otherwise, I sent him some examples of the Carboniferous form. Mr. Etheridge was much struck with their apparent resemblance, but as he only knew the Silurian object from polished sections, his determination could go no further.

In assigning this little fossil to *Hyperammima vagans*, it is needful to state that though its zoological characters and general habit correspond with those of the recent species the diameter of the tube is much smaller than that of any living specimen hitherto described. Further, that in some instances the transverse fracture of the tube, and the apparent absence of proper investment on the attached side, suggests an affinity with the genus *Webbina*; though in other cases this is not apparent.

*Distribution*.—Only known from the "D" Limestone of the Tipalt in which it is by no means a rare form.

### Family LITUOLIDÆ.

#### Sub-family Lituolinæ.

#### Genus PLACOPSILINA, d'Orbigny.

*Placopsilina cenomana*, d'Orbigny. Plate VIII. fig. 4.

The "D" Limestone, which has added so much to our knowledge of the Palæozoic Foraminifera, is especially rich in adherent forms. Amongst these there occur some few which exhibit a close resemblance in texture and habit of growth to the above species. The test is somewhat coarsely arenaceous, imperfect on the side of attachment, generally more or less spiral in manner of growth (though often a very open spiral), and exhibits at irregular intervals constrictions of the testaceous tube, suggestive of septal divisions. The tube varies considerably in size in different individuals, varying from 1/200 in., or less, to 1/75 in. in diameter. The drawing given in Plate VIII. fig. 13 may be taken as an average specimen.

*Distribution*.—Only known in connection with the "D" Limestone, Tipalt, growing adherent to small fragments of shell and other objects.

#### Genus LITUOLA, Lamarck.

*Lituola rotundata*, sp. nov. Plate VIII. figs. 5, 6.

Test free, globular, subglobular, or, more rarely, subcylindrical; spiral, nautiloid, more or less asymmetrical, consisting of about five or

six chambers, four of which are commonly visible externally; chambers globose, increasing rapidly in size, the final segment very large, slightly overlapping and generally equal in size to the rest of the shell, giving a ventricose appearance to the oral extremity. Septal divisions often confused and labyrinthic. External surface rough. Aperture compound or cribriform, very distinct, and situated on the convex surface of final segment. Diameter of globose example  $1/50$  in.; subcylindrical,  $1/30$  in., long diameter.

This form is easily distinguished from *Lituola Bennieana*, Br. by its much smaller size, more rounded form, the fewness of its chambers, their greater inflation, and the position of its compound aperture. The aperture, which generally is very clearly visible, occurs, not on an incurved septal face, but on the convex part of the final segment, suggestive of a rectilinear growth. Fig. 5, whilst a fairly typical example in other respects, exhibits this feature in a less degree than the average number of specimens. The tendency to variation in this species is in the direction of a partial uncoiling of the spire, and some individuals even exhibit intermediate gradations with the crozier-shaped members of the genus. A comparison of the transparent vertical section given of *L. Bennieana*, Plate VIII. fig. 7, with a similar section given of the present species, Plate VIII. fig. 6, will give a fair idea of the distinctive features of their internal structure. The only form with which *L. rotundata* is likely to be confounded in the Carboniferous shales, is *Valvulina bulloides*, Br. I have not had the good fortune to obtain this latter form from the district concerned in the present investigations; but, judging from Mr. Brady's excellent drawings, the concave surface of the oral extremity of *Valvulina bulloides*, as well as the very distinctive apertures, in each case, would be easy guides to their identification.

*Distribution*.—It is not a very frequent form. It is rare in the Great Limestone of Curry Hill, Allendale; moderately common in the "D" Limestone of the Tipalt, and was recognized in transparent sections of the "K" Limestone, Cowburn.

*Lituola Bennieana*, Brady. Plate VIII. fig. 7.

In the schemes of classification where the perforate or imperforate character of the test was made a ground of primary division among the Foraminifera, the genus *Lituola* was placed among the "Imperforata." Mr. Brady's reasons for rejecting this principle of classification receive from time to time additional justification. The artificial nature of this method of division has received conspicuous illustration in that, whilst the Lituolidæ are normally imperforate, the large Carboniferous species, *L. Bennieana*, is frequently coarsely perforate. This has been demonstrated by several sections made both in horizontal and vertical directions, in which the perforate character of the test is equally manifest. Plate VIII. fig. 7 is one such section, taken vertically, which also shows, in this individual, an aperture at the inner margin of the terminal segment.

The chambers are much more numerous than in *L. rotundata* (nearly double) and less globose. Long diameter  $1/28$  in.

*Distribution*.—I have notes of the occurrence of this fine species in twelve samples of material, viz. the Felltop Limestone, at Wolf Hills, near Haltwhistle; First Lower Felltop, Thornbrough; Great Limestone, of Allendale; Small Limestone, of Nenthead; "D" Limestone, of Tipalt and Cowburn valleys; and the "J" Limestone, in Tipalt. In the Thornbrough quarry I obtained it from five horizons, and in the majority of these it was a common form.

### Sub-family Trochammininæ.

#### Genus WEBBINA, d'Orbigny.

#### *Webbina hemisphærica*, Jones, Parker, and Brady.

In the rich material of the "D" Limestone there are frequent examples of a monothalamous and adherent Foraminifer which appear to me to belong to this species. The test is convex and imperfect on the side of its attachment. The degree of convexity varies from a somewhat low relief to almost subglobular. The margin is at times slightly spreading, and not unfrequently exhibits a clear space between some parts of the edge of the test and the object to which it is attached. It is a minute form, not exceeding  $1/50$  in. in diameter. It is an interesting feature to find this rare form, which has hitherto only been known in the living state as dredged off the coast of Durham, and as a fossil by a single specimen from the Suffolk Crag, with so high an antiquity as these Palæozoic examples confer upon the species.

*Distribution*.—Only known in the Carboniferous rocks in connection with the "D" Limestone, Tipalt.

#### *Webbina fimbriata*, sp. nov. Plate VIII. figs. 8, 9.

Test thin, adherent; in shape, convex or subconical; normally monothalamous, sometimes two or three grouped together and connected by minute stoloniferous tubes; margin attenuated, spreading, and deeply notched, giving the test a fringed or stellate appearance. Stellate projections numerous, short, raised, and tubular, sometimes open at their extremities. Diameter of test  $1/100$  in.

This is a very pretty little shell, and makes a conspicuous object by its white colour shown on a dark background. The test is to all appearance finely arenaceous and very thin, and owing to this latter fact most of the examples have the test broken at the apex, as shown in one of the figures. Some of the fractures probably date from a period prior to the fossilization of the specimens. Its habit of growth, in throwing out tubular extensions from a primordial chamber, gives it a likeness to *Webbina clavata*, and it is more closely isomorphic with *Placopsilina vesicularis*, Brady; but it differs from the former species in the number and stellate form which these tubular processes assume, as well as in their very short length, seldom exceeding a length greater than the diameter of the chamber from which they emanate; whilst the finely

arenaceous texture of the test at once distinguishes it from the coarser Placopsiline species. The radiating tubuli undoubtedly formed the general apertures of the test, they sometimes bifurcate, and there is commonly a thin film or weblike extension of the testaceous envelope partly covering the spaces separating the tubuli.

*Distribution*.—It is rather a common form in the "D" Limestone, where it is found attached to a great variety of objects, but I have not found it at any other horizon in the district.

*Webbina irregularis* d'Orbigny. Plate IX. figs. 16, 17.

There can be little doubt, I think, that figs. 16 and 17 represent examples of this species. Although differing in some respects from the recent form, they carry clearly marked *Trochamminina* characteristics. The test is typically, although not constantly, oval in shape; finely arenaceous in structure, smooth externally, and imperfect on the side of attachment. The segments are arranged in a moniliform order, and sometimes in several parallel and adjoining series of such an order of arrangement. The features of divergence from the modern examples of the species, exhibited by the Carboniferous specimens, are in the direction of a greater thickness of test, the stoloniferous connection between the chambers is often imperfectly developed, the division of segments being at times marked by a simple constriction of the test rather than by stoloniferous tubes; whilst in many examples there is an approach to the cylindrical form by the margin of the chambers almost coalescing on their under sides when the object on which they have grown has been a column of small diameter.

These divergences may be regarded as features of minor consequence where the general agreement to the type is so close. Average size of segments, long diameter  $1/75$  in.; short diameter  $1/125$  in.

*Distribution*.—Very rare in Great Limestone of Blagill, Allendale, but common in the "D" Limestone of the Cowburn and Tipalt outcrops.

#### Sub-family Endothyrinæ.

Genus ARCHÆLAGENA, NOV.

Syn. *Lagena* (in part), Brady.

Shell parasitic or free; either monothalamous or polythalamous. Chambers inflated; ovate, subglobular, or irregular in shape. Polythalamous examples confused in arrangement. Test thicker than in the typical *Lagenidæ*; finely perforated. Texture either entirely calcareous or with only a small proportion of included arenaceous particles. Aperture at the termination of a short neck; in parasitic examples the orifice may be defective on the side of attachment, and is then a semicircular, slightly produced lip.

The genus now described may be regarded as bearing a similar relation to *Lagena* that *Nodosinella* bears to *Nodosaria*. In both cases we probably possess ancestral, generalized types, from which have diverged distinct lines of modification leading up to more specialized

forms of recent times. The not unfrequent duplication, seen in aberrant examples among recent *Lagenæ*, may, perhaps, be instances of reversion to type, as seen in the polythalamous examples of Carboniferous times, and included in the present genus.

*Archalagena Howchiniana*, Brady, sp. Plate IX. fig. 18.

Mr. Brady's description of the monothalamous examples of this species is a very accurate one, and needs no adjustment. A more extended acquaintance with this form has, however, shown that it is much more commonly polythalamous than monothalamous in its habit of growth. The chambers usually number from two to twelve, and, in rare cases, even up to nearly twenty, and are irregularly grouped around the axis of growth. The method of growth is apparently by budding. The chambers differ greatly in relative size, and many show more or less distortion in shape by compression through the concurrent growth of adjoining segments. There may be one or more general orifice to each group of united segments, the latter communicating by interseptal apertures.

Possessing the morphological and structural characteristics now described, *Archalagena Howchiniana* can no longer be consistently regarded as belonging to a genus which is essentially monothalamous. On the other hand, *Lagena Parkeriana*, and *L. Lebouriana*, although exhibiting in test structure some points of resemblance to the forms classed under the present species, have never been met with except as single-chambered and free examples, and may therefore be left, at least for the present, in the position assigned them by Mr. Brady.

*Distribution*.—Not very common; recorded in connection with twelve washings from the following:—First Lower Felltop, at Penpeugh; at various localities and horizons of Great Limestone; and from the "D" Limestone of Tipalt and Cowburn, the last-named limestone being the best bed for the form.

Genus *ENDOTHYRA*, Phillips.

*Endothyra conspicua*, sp. nov. Plate IX. fig. 12.

Test nearly circular in lateral outline, compressed, slightly asymmetrical bi-laterally, composed of about three convolutions, all of which are more or less visible exteriorly. Segments inflated, sub-globular, from ten to twelve in the outer whorl. Diameter of large specimens  $1/20$  to  $1/16$  in.

This is an interesting variety in which the usually embracing character of the genus is but feebly developed. It has probably its closest relationship with *E. Bowmani*, some examples of which exhibit a considerable umbilical depression not embraced in the fold of the outer convolution. It is, however, easily distinguished from the latter species, by its more circular outline, its more numerous and globular-shaped segments, and, more particularly, in the exposure of the inner whorls which are often visible throughout their entire convolutions. In

*E. ammonoides* there is the same exposure of the inner whorls by the only slightly embracing character of the test, but its minute size and the number of its convolutions and septal divisions at once distinguish it from the present species. This departure from the normal character of the genus, shown by *E. conspicua*, is not likely to have arisen from starved conditions as some of the individuals attain a larger size, exceeding those of *E. Bowmani*, whilst the beds in which they occur are somewhat rich in Foraminifera.

*Distribution.*—Rare in the “J” Limestone of the Tipalt, and in a limestone, low in the series, situated in a burn between The Banks and Lannercost, occurring at three horizons in the limestone, in one of which it is moderately common.

*Endothyra circumplicata*, sp. nov. Plate VIII. figs. 10, 11.

Test free, subglobular, irregularly spiral, embracing; composed of three or more convolutions, which, instead of following the same plane of growth throughout, become twisted, so that the later convolutions are formed more or less at right angles to the plane of the earlier segments. Segments numerous, and in their later growths enlarging rapidly and becoming ventricose. Later chambers subdivided near their umbilical margins by transverse septa. Septal divisions marked externally either by depressed lines or slight limbation. Test plicate. Exterior surface smooth; white or reddish-white. Texture finely arenaceous, and in some cases (?) perforate. The final segment has a protruding lip forming its convex or outer margin, with a corresponding lip or ridge transverse to the peripheral margin and parallel to the inner margin of the septal plane. Aperture distinct, oval. Diameter  $1/25$  in.

This striking variety exhibits an extreme of inequilateral growth. In its large size and globose form it somewhat resembles *Endothyra crassa*. The latter includes the “nearly symmetrical,” large, globose *Endothyrae* of the Carboniferous rocks, whilst *E. circumplicata* is extremely unsymmetrical, and from this cause exhibits considerable divergence in internal structure from its more equilateral congeners. The umbilical axis is not unfrequently shifted in position by the inequilateral plan of growth to the peripheral margin. Transparent sections show in many instances a remarkable confusion in the arrangement of the earlier chambers with successive foldings, amounting in some cases to two, three, or four plications of the shell substance; and in the expanded chambers of the final whorl, transverse septa, giving rise to small chamberlets, near the umbilical margins of the terminal segments. The last segment is sometimes much contracted by vertical compression towards the aperture, taking the form of a slit which, with its pouting margins and great obliquity of the septal plane, gives the shell a very grotesque appearance. The shelly investment, consequent upon the laminated construction of the test, is very stout in comparison with the other *Endothyrae*, especially in its earlier convolutions, and has a clear, smooth, and sometimes

glossy surface. The test, whilst finely arenaceous, exhibits great uniformity of structure, and when viewed in section by transmitted light exhibits a peculiar white opacity of texture not commonly seen in members of this genus.

*Distribution.*—It is a form apparently much limited in distribution. Recorded in four samples, three of these belonging to the "D" limestone of the Cowburn and Tipalt districts, and the other in "K" limestone, near West Stone Folds, Cowburn. In the "D" limestone it is common.

*Endothyra radiata*, var. *Tateana*, nov. Plate IX. figs. 13–15.

Test free, nautiloid, nearly circular in peripheral outline, compressed laterally, embracing, umbilicus sunken, slightly inequilateral, peripheral margin thin or subcarinate; convolutions numerous, five to six in fully grown examples; chambers very narrow and numerous, from 25 to 40 in last convolution; septal walls double; sutural lines slightly excavated; septation sometimes indistinct and often showing considerable irregularity in arrangement on exterior surface. Texture finely arenaceous with large proportion of calcareous cement. Diameter of fully grown specimen  $1/25$  in.

A fine variety of *Endothyra*, differing in some minor particulars from *E. radiata*. The shell attains about twice the diameter of typical specimens of the latter species; it is more symmetrical and compressed, and the segments are more numerous and less regular, often showing crenulations, meeting at various angles on the surface of the test. The duplication of the septal walls is also an important feature, and one that has not been observed in connection with any other members of the genus. It is well seen, not only in transparent sections of this form (Plate IX. fig. 15), but in those examples which have been subjected to a degree of weathering, as shown in fig. 14 of the same plate. The double septation gives a higher character to the genus than was at first indicated, and is another feature confirmatory of Mr. Brady's opinion, expressed when working out this interesting palæozoic type, of the close analogy which the genus bears to the more recent and distinctly calcareous Rotaline series, with which *Endothyra* in its various modifications is closely isomorphic.

I have great pleasure in associating this variety with the name of the late Mr. George Tate, F.G.S., of Alnwick, who was one of the earliest and most enthusiastic students of the palæontology of Northumberland.

*Distribution.*—*Endothyra radiata*, var. *Tateana* is not uncommon in the lower Carboniferous beds of south-west Northumberland. It was noted in the upper beds of the Great Limestone at Blagill, Alston; but all of the twenty-four localities in which it has been observed, with the exception just noted, are at horizons included between the "B" and "N" limestones of the Cowburn and Tipalt valleys.

## Genus STACHEIA, Brady.

*Stacheia moriformis*, sp. nov. Plate IX. figs. 19, 20.

Test parasitic (or free?); globular, subglobular, or, more rarely, elongate or complanate in shape. Chambers larger than those of allied species, more or less rounded in outline, and often showing a roughly concentric or spiral arrangement of segments around the axis of growth. Chambers of the superficial layer inflated and tumid, raised in hemispherical bosses upon the surface of the test; walls very thin, often abraded on their convex surfaces so as to expose the darker material filling the interior of the chambers. Diameter of globose examples, from 1/30 in. to 1/25 in.

This species is pretty constant in character, and cannot well be confounded with any other of the Carboniferous Foraminifera. Its globular form and conspicuously inflated chambers are ready means of identification. It is often impossible in the other members of this genus to mark any superficial indications of the septal divisions, and when distinguished they are made apparent only by a faint areolation or mottled appearance of the exterior surface: but in *Stacheia moriformis* the superficial chambers are not unfrequently elevated to the extent of half their diameter. The test is not nearly so compact as in the allied species, and the chambers are relatively larger, whilst the shelly investment is remarkably thin. In this respect, and from a greater or less tendency to a spiral arrangement in building up the test, there is some morphological analogy to the acervuline modifications of *Planorbulina*, especially when *S. moriformis* has grown parasitically on a flat surface; but the subarenaceous and imperforate characters of the test show its affinity to be with the *Endothyrinæ* rather than the recent perforate and hyaline forms.

*Distribution.*—*Stacheia moriformis* is not very common in point of number of specimens, but is widely distributed through the Carboniferous Limestones of the North of England. It occurs in fifty-two washings gathered from the following horizons:—First Lower Felltop, Second Lower Felltop, Great Limestone, Four-fathom Limestone, and the “D,” “E,” “G,” “J,” “N,” and “O” Limestones.

## Family LAGENIDÆ.

## Sub-Family Nodosarinæ.

## Genus NODOSARIA, Lamarck.

*Nodosaria (Dentalina) farcimen*, Soldani. Plate IX. fig. 21, a, b.

Amongst the many interesting forms which the “D” limestone has revealed must be included the above species. Its lowest stratigraphical record hitherto known has been the Upper Permian, where it is found associated with several other cognate forms. No unquestionable Nodosarian had been found in rocks older than the Permian. It is, therefore, of some interest to secure examples of this common recent species so far back as the Carboniferous Limestone. In

the Permian seas it was scarce, and apparently was still more rare in Carboniferous times, when the arenaceous types were in the ascendant. Only one undoubted example of this species was obtained from the material searched, but with the exception of exhibiting a mineralization corresponding to the much older formation from which it was obtained, it does not materially differ from the examples of later age. It is a minute shell with a clear calcareous appearance. Test slightly compressed laterally. The chambers, which are elliptical in shape, number six, in a curved linear series, and increase somewhat rapidly in size in the direction of growth. Septal lines marked by oblique and rather deep constrictions. Primordial end apiculate. Length  $1/28$  in.

*Distribution.*—Only known from the "D" Limestone, Tipalt; rare.

### Family ROTALIDÆ.

#### Sub-family Rotalinæ.

#### GENUS PATELLINA, Williamson.

#### *Patellina Bradyana*, sp. nov. Plate IX. figs. 22–25.

Test free; conical; trochoid; primordial end obtusely pointed; transverse section circular; length equal to two or three times the diameter of the test; inferior side slightly concave; external surface limbate, exhibiting numerous annular, semi-annular, or spiral whorls of raised shell-substance alternating with lines of depression; depressed areas bridged by minute crenulations of the test, which, as raised transverse lines, connect the limbate septal ridges. Internal structure a simple, undivided and continuous spiral chamber (or alternating semi-annular chambers?). Chamber cavity compressed. Umbilical region extending almost the entire length of the shell and of nearly equal diameter throughout, filled with uniform shell-substance. Convolution of spire varying from five to twelve; average number ten. Aperture a narrow slit, extending from the periphery to the umbilical margin. Umbilicus depressed; or, frequently, marked by a raised lip extending from the umbilical termination of the orifice, forming a low, semicircular wall defining the central portions of the test. Length about  $1/38$  in.; diameter, at base,  $1/100$  in.

This is, perhaps, the most interesting find in the present group of new forms. The oldest record of *Patellina* has not, hitherto, extended beyond the Cretaceous formations, in which, as well as in rocks of early Tertiary age, the genus was represented by shells of relatively large size and complicated structure. The common recent species, *P. corrugata*, exhibits to some extent the subdivision of chambers by secondary septa, so remarkably developed in some of the earlier forms. The Carboniferous examples are of a simpler type, and do not possess any subdivision of the chamber cavities. Mr. H. B. Brady, in the "Challenger Foraminifera," describes a new recent species, *Patellina campanæformis*, which shows the same simple and undivided chamber

(or chambers) as in *P. Bradyana*, and it seems probable that the palæozoic form has its nearest relationship with this interesting but extremely rare species of the present day. The recent species combines the twofold plan of growth, of semi-annular, crescentic segments in the early whorls, with a true spiral form of chamber in the later whorls. From a careful examination of several transparent sections of the test of *P. Bradyana* I cannot satisfy myself that it conforms to the normal type, with respect to an alternating series of semi-annular segments, but appears to exhibit the generic characters under the simplest possible form, that of a non-segmented spiral chamber with the spire drawn out from the primordial plane to that of an elongated cone. Its spiral growth gives it a likeness to *P. Cooki*, although wanting the subdivision of chambers seen in that species. The bridging of the lines of depression by shelly matter, between the raised sutures on the external surface, may have been the foreshadowing of that modification of the type which, in later ages, became more definite in the subdivision of the chamber cavities. The chief variations to which the Carboniferous form is subject are in the height of the spire, the occasional irregularities of the limbate outlines of the chamber walls—the latter, at times, being subject to interruption or coalescence—or an abnormal constriction or inflation of the test at some stage of its growth, producing more or less distortion of outline. The umbilical region is filled with calcareous shell-substance which in section has a mottled appearance, but is unsegmented. The only species with which *Patellina Bradyana* is likely to be confounded in Carboniferous material are *Valvulina palæotrochus* or *V. Youngi*, but *P. Bradyana* has a shorter transverse diameter in comparison with its length than either of these forms, its numerous limbate sutures are also distinctive, whilst the respective apertures and internal structures are widely different.

As the most striking addition to our knowledge of Carboniferous Foraminifera, I have much gratification in associating with the species the name of Mr. H. B. Brady, to whose researches we are indebted for the first systematic treatment of this group of palæozoic fossils.

*Distribution.*—Only known from the "D" Limestone of the Tipalt and Cowburn outcrops.

---

With this species I may fitly conclude my notes. In the present series details have been given of four genera and of thirteen species and varieties not previously known as Carboniferous fossils, some of them of peculiar interest. As has already been stated I have still a number of specimens which appear to me to belong to the Foraminifera, and if so to types hitherto undescribed, but these I withhold for the moment in the hope of obtaining further evidence respecting them.

SUMMARY  
OF CURRENT RESEARCHES RELATING TO  
ZOOLOGY AND BOTANY  
(*principally Invertebrata and Cryptogamia*),  
MICROSCOPY, &c.,

INCLUDING ORIGINAL COMMUNICATIONS FROM FELLOWS AND OTHERS.\*

ZOOLOGY.

A. VERTEBRATA:—Embryology, Histology, and General.

a. Embryology.†

**Kinetic Phenomena of the Egg during Maturation and Fecundation.**‡—Dr. C. O. Whitman finds that the oökinetic phenomena are diversiform in the extreme, rarely present regular form-series, and so stand in marked contrast with nuclear metamorphoses, which, everywhere, both in plant and animal cells, exhibit a most remarkable uniformity. With regard to the movements of the germinal vesicle and pronuclei, the author, from the unique character of many of these cytokinetic displays, refuses to consider them as the direct effect of nuclear influence. Any hypothesis that refuses to admit that the cytoplasm is endowed with subtle powers of its own, is unable to account for the characteristic difference between telolecithal and centrolecithal eggs. The remarkable phenomena observed in developing eggs must be due to the interaction of nuclear and cytoplasmic forces. There is little evidence, in the explanation which is usually given, to support the view that the pronuclear asters attract each other. When, however, a careful analysis is made, we find three facts which can be said to furnish indisputable evidence of attraction between the pronuclei. These are—(1) The curved path of the male pronucleus in the amphibian egg; (2) The meeting of the pronuclei before reaching the centre of equilibrium; and (3) The centrifugal movement of the earlier pronucleus to meet the more lately formed pronucleus. The author amplifies these points.

In discussing the receptivity of the ovum for spermatozoa, the distinction between receptivity and accessibility is very generally ignored. Dr. Whitman believes that the period of receptivity may be said to date from the moment the conditions of centripetal attraction are reversed in the germinal vesicle. A period of non-saturation begins with the centri-

\* The Society are not intended to be denoted by the editorial "we," and they do not hold themselves responsible for the views of the authors of the papers noted, nor for any claim to novelty or otherwise made by them. The object of this part of the Journal is to present a summary of the papers *as actually published*, and to describe and illustrate Instruments, Apparatus, &c., which are either new or have not been previously described in this country.

† This section includes not only papers relating to Embryology properly so called, but also those dealing with Evolution, Development, and Reproduction, and allied subjects.

‡ Journ. of Morphol., i. (1887) pp. 227-52.

fugal movement of the germinal vesicle, and terminates with the penetration of the spermatic body. As soon as all the elements of saturation are present, external manifestations of centripetal attraction cease, and there remains only the work of internal equilibration, which ends with the centripetal march of the pronuclei.

From this point of view it is idle to talk about mechanical contrivances for preventing the admission of supernumerary spermatozoa, as if the receptivity of the ovum were not self-regulating. The idea that the spermatozoon remains passive until after the extrusion of the polar globules seems to be quite erroneous.

In the copulation of the sexual cells, the most interesting point is that attraction between the ooplasm and the spermatozoon can manifest itself at a distance. This fact is, however, not quite unique, for something analogous is seen in the attraction between the pronuclei. There are, it seems, two distinct kinds of attraction; there is that of one nuclear body upon another, which may be called nuclear attraction, and the action of nuclear bodies on the ooplasm which manifests itself in astral lines, and which may be called centripetal attraction. The attraction of the egg for the spermatozoon is probably polar, and the place of penetration a predetermined point or region. On this point, however, the evidence is very conflicting; the most important memoir on this point is that of Kupffer and Benecke on the fertilization of the egg of the lamprey. The important points in this and in other essays are indicated by Dr. Whitman.

**Human Ovum.\***—Dr. W. Nagel gives a full account of his observations on that rare subject of satisfactory investigation—the human ovum. The principal results have been already noticed.†

The first part of the lengthy paper is taken up with historical reference to previous observations, of which a full bibliography is appended. After describing his material and mode of investigation, the author discusses and figures the primordial ovum and primary follicle, the subsequent growth of both of these, and the conditions observable in maturity. In the latter, he describes (1) the epithelium of the ovum; (2) the zona pellucida; (3) a perivitelline space; (4) a narrow, clear cortical zone of the vitellus; (5) a broader, finely granular, protoplasmic zone; (6) a central deutoplasmic zone; (7) the germinal vesicle and spot. The ovary of a newly born child and that of an ape (*Macacus*) are described, and many relevant questions are incidentally discussed.

**Spermatogenesis of Mammals.‡**—Prof. V. v. Ebner communicates an important memoir on the spermatogenesis of mammals, in which he resumes the investigation which he busied himself with seventeen years ago. He discusses in the first two chapters the nomenclature employed by investigators, the material and method of investigation, and the actual state of the question. In a third chapter he investigates the relation of the basal nuclei of the spermatoblasts to the cells of Sertoli and the spermatogonia of v. La Valette St. George. Fourthly he shows in what cells within the testicular canals division is really to be observed. Then he discusses the granular excretions of the spermatoblasts, the absorption of the fat by Sertoli's cells, and the general physiology of the spermatoblasts. The last chapter is occupied with a description of the topo-

\* Arch. f. Mikr. Anat., xxxi. (1888) pp. 342-423 (2 pls.).

† See this Journal, 1887, p. 932.

‡ Tom. cit., pp. 236-92 (3 pls.).

graphical distribution of the various developmental stages, and with a discussion of the conclusions to be drawn from these.

The true spermatogonia are the cells of the peripheral layer. They multiply in that position by indirect division. The spermatogonia grow into spermatocytes (= Henle's cells) each of which, after double division, produces four spermatides (= sperm-cells). Then a large number of spermatides, originating from several spermatogonia, come into association with a follicular cell (= Sertoli's cell), and form a spermatogemma (= spermatoblast). In this finally the spermatozoa (= spermatozoa) develop from the spermatides. By this von Ebner declares his determination to abide, unless some firmly established counter observations are forthcoming.

Embryology of Lizard.\*—Dr. H. Orr has worked chiefly at the development of *Anolis sagrei*, but has also examined some stages of *Sphærodactylus notatus* and *Liocephalus carinatus*. The notochord arises by a differentiation of the linear median area of the dorsal wall of the primitive intestine; and this condition seems to be primitive, for the notochord continues as far as the anterior extremity of the intestine. The mode of development of the notochord and hypophysis seems to point to some peculiar relation between the two organs; with these the muscular elements of the head are intimately related. At an early stage there is seen to be a median connection of the head-cavities and notochord, which the author proposes to call the cœlenteric zone. The first appearance of the tip of the notochord, the cœlenteric zone and head-cavities, is in the form of a small mass of cells, apparently budded from the hypoblast. This mass is fused with the epiblast. In some individuals the notochord and cœlenteric zone separate from the epiblast at the same time, though retaining connection with each other. In other individuals the cœlenteric zone separates from the epiblast much earlier than does the notochord, and disappears; while the notochord remains a long time connected with the epiblast or hypophysis.

The oral fusion of epiblast and hypoblast is effected very early. The gill-cleft rudiments first appear as paired pouch-like protrusions from the dorso-lateral parts of the alimentary canal; the first and second are the first and second clefts, and are the first to acquire an external opening; then, in order, the third and fourth, but the fifth rudiment does not seem to get an external opening. The part of the alimentary canal from which the gill-clefts open is, comparatively, extremely large. On the ventral surface of the large gill-chamber the first rudiment of the thyroid gland appears. In horizontal section it has a circular outline; it is a compact thickening of the wall of the gill-chamber, and its cells are arranged radially. The caudal intestine appears to continue to grow in the neurenteric region, even after its anterior part behind the anus has atrophied; this atrophy obtains from before backwards, and for a time the proximal end seems to atrophy about as fast as the distal end grows.

The segmentation of the mesoblast into somites is effected from before backwards, and the first somite appears at just the distance behind the ear that would equal the space occupied by one somite. With regard to the mode of origin of the segmental duct, about which much has been recently written, Dr. Orr states that near the region of the neurenteric canal, opposite that part of the unsegmented mesoblast which has not

\* Journ. of Morphology, i. (1887) pp. 311-63 (5 pls.).

yet divided into a dorsal and a ventral part, there appears a small linear thickening of the epiblast. This thickening is the same on either side, and lies horizontally and a little above the level in which the intermediate cell-mass is to appear. Posteriorly this epiblastic thickening fades away, but in the direction of the head it becomes more marked, and appears in cross-section as a distinct semicircular clump of five to eight cells adhering to the epiblast. A little further forward it becomes gradually separated from the epiblast, and lies as a solid cord about midway between the epiblast and the rudiment of the Wolffian body. Still further forward the cord of cells acquires a lumen, and lies in contact with the Wolffian body, so that it is now easily recognizable as the segmental duct. The development of the circulatory system agrees generally with the account given by Shipley of the same system in *Petromyzon*. This portion of the paper concludes with an account of the development of the brain.

In the second part the bearing of the facts of the development of the Lizard on certain speculations regarding the phylogeny of the Vertebrata is pointed out.

**Gastrula of Amphibians.\***—Dr. Schwinck discusses the nature of the gastrula in amphibian development. *Bufo vulgaris*, *Rana temporaria*, and *Triton alpestris* were investigated. The clearest results were obtained from the study of *Bufo*; frog ova are more difficult. The general conclusion established is that the whole of the endoderm, including the dorsal portion, arises from a differentiation of yolk-cells. The gastrula of Amphibians occupies a midway position between that of *Selachia* and that of *Amphioxus*. In all, the dorsal blastopore wall is the more active, and it is there that the formation of endoderm first begins. "At the close of gastrulation, an archigastrula might be hypothetically formed from the amphigastrula by supposing the yolk-cells to be replaced by a single layer of endoderm."

**Development of *Petromyzon fluviatilis*.†**—Prof. A. Goette has a preliminary notice of his observations on the development of *Petromyzon fluviatilis*. Gastrulation is effected as in the Amphibia; the archenteron commences with the prostoma, which lies beneath the germinal cavity; its dorsal wall becomes differentiated into ecto- and endoderm, and this differentiation is continued on to the lateral parts of the thick lower half. The mesoderm does not appear till gastrulation is complete, when it is developed in the dorsal endoderm. This is at first multilaminar, and the lower layer gives rise to mesodermal plates. Segmentation of the mesoderm commences in the anterior portion of the region of the trunk, and is thence continued backwards and forwards.

The notochord is developed in the way described by Calberla; its hinder end has at first no definite termination, but is lost in the cell-mass at the dorsal margin of the prostoma, where the ectoderm passes into the endoderm. There is no neurenteric canal in the embryos or larvæ of *Petromyzon*; the prostoma becomes the anus, and the primitive lumen of the mid-gut is replaced by a second which arises more deeply, while the primitive lumina of the fore- and hind-gut are retained.

The spinal nerves do not arise in the way described by Sagemehl; the several rudiments of the spinal nerves become, secondarily, dorso-

\* Biol. Centralbl., viii. (1888) pp. 29-31. † Zool. Anzeig., xi. (1888) pp. 160-3.  
1888.

lateral appendages of the medullary tube, but they are not outgrowths of it, but purely epidermal structures. The first rudiments give rise to the dorsal roots and their ganglia, while the ventral roots do not arise till later; they are not, either, independent outgrowths of the medullary tube, but connections between it and the adjacent ganglia, which gradually become drawn out into cords. The rami dorsales grow out from the upper end of the ganglia, and the separation, therefore, into sensory and motor fibres does not correspond with the development of the dorsal and ventral roots. In addition to the spinal nerves, and independently of their rudiments, the lateral nerve appears as an epidermal ganglionic mass which, later on, becomes connected with the root of the vagus, and grows out horizontally backwards; there are also five ganglionic bodies within the mesoderm or above the gill-pouches, which only secondarily enter into connection with one another, and with the vagus; they give off branchial branches. The whole peripheral nervous system does not therefore arise as one, nor even from one and the same germinal layer. The histogenesis of the nervous system of *Petromyzon* is essentially similar to that of the Amphibia; the nerve-fibres and nerve-cells appear separately, and only become connected secondarily.

The formation of mesodermal segments is continued as far as the most anterior end of the head; as in the Amphibia, the head consists of four mesodermal segments; they give rise to the trigeminal, facial-auditory, glossopharyngeal, and vagus nerves; the hypoglossus is regarded as the first spinal nerve of the trunk. The eight gill-sacs are homologues of the inner gill-sac of the anurous Amphibia; the "enteric gills" of the lamprey are therefore essentially distinct from the ordinary "dermal gills" of Fishes and Amphibians.

The heart is developed behind the branchial region below the œsophagus, so that the pericardial cavity communicates superiorly with the cœlom; the endocardium is formed by the endoderm, and the blood is formed in the ventral endoderm behind the rudiment of the liver. In correspondence with the position of the heart the pronephros lies exactly above the pericardiac cavity.

Egg-shell of *Lepadogaster*.\*—M. F. Guitel has investigated the mode of attachment of the eggs of *Lepadogaster*. With moderate magnification a small clear circle surrounded by a dark zone may be seen at the centre of the base of the shell of *L. bimaclatus*. Towards the centre a number of small rods may be seen to converge. They are cylindrical and bifurcated, and are longest at the edge, where they project around the base of the egg. At the moment when the egg is laid, the two terminal filaments of each small cylinder are soft, and they easily fix themselves to the least asperities of the surface to which they are applied; they then harden, and the egg is thus firmly attached to the substratum on which the mother has deposited it. The author finds that this fixation apparatus is secreted by the follicle of the egg, the follicle itself being derived from the germinal epithelium. Moreover, the secretion is on the hemisphere of fixation, and this is always the one which is directed outwards. In a perfectly ripe ovary all the eggs have the hemi-ellipsoidal form of the deposited egg, and they are all attached to the wall of the gland by the surface which, after oviposition, will be fixed by means of the fixing-apparatus.

\* Comptes Rendus, cv. (1887) pp. 876-8.

**Albuminoid Constituents of White of Egg.\***—MM. G. Corin and E. Berard have investigated the albuminoid constituents of the white of egg. They find that of those which are coagulable by heat two belong to the class of globulins and three to that of true albumins; the quantity of peptones increases with the age of the egg. There is a colouring matter which is not coagulated by heat, but is taken up by every coagulation which occurs in it. The albumins strictly so-called have, when made opalescent by an increase of temperature, a property which has hitherto been supposed to be peculiar to globulins; that, namely, of being precipitated by sulphate of magnesia. It is possible that albumin, just before coagulation, passes through a stage in which it has the composition and properties of globulins.

**Embryochemical Investigations.†**—Prof. L. Liebermann has investigated some of the less well known constituents of the egg of the fowl. He finds that the germinal disc chiefly consists of albuminoid bodies, belonging apparently to the globulin group; there seem to be also smaller quantities of lecithin or some similar substance. Few fatty acids were found in the yolk. The fat of the egg consists of a mixture of a solid and a fluid fat with some cholesterin. The firm fat consists chiefly of tripalmitin with, probably, a very little stearine; the fluid or true oil of the egg is a glyceride. Both are much poorer in carbon than other animal fats. The fat of fresh unhatched egg does not contain any considerable quantity of free fatty acids, which are, however, developed to a considerable extent during hatching. Fowls' eggs do not contain any appreciable quantity of organic phosphates,—there is, however, a relatively large quantity of calcium which probably exists in the form of calcic albuminate; there is no direct evidence of the presence of sulphates; the quantity of chlorine is variable, but it is not certain on what the variability depends. There may be other inorganic constituents, but, if so, their amount must be very small. The albumen of the egg is capable of forming, in the presence of strong acids, phosphates with the phosphoric acid, while, in the presence of dilute acids, soluble organic phosphates are formed.

In the second portion of the essay the metastasis of the egg while being hatched is dealt with. The embryo itself always becomes richer in mineral matters, fat, and albumen, but the dry substance of the whole contents of the egg, taken as a whole, diminishes considerably; the considerable increase in the fat of the chick is not due to the formation of fresh fat, but is chiefly dependent on the fact that what remains of the nutrient yolk is taken up into the abdominal cavity of the chick. The constituents of the egg are used up regularly during the period of hatching; the quantity of mineral matter remains almost unaltered. Notwithstanding the taking up of oxygen, there is a loss in the amount of that gas. The loss in weight suffered by the egg is obscured by the evaporation of water; the undeveloped egg loses more water than the developed, and on the last day of hatching the ripe chick in the egg contains more water than an equal quantity of unfertilized egg-matter. The embryo uses up oxygen, of which a part only becomes carbonic acid; this indicates the formation of a fresh quantity of water.

The special chemistry of the embryonic body is next dealt with. In

\* Bull. Acad. R. Sci. Belg., lvii. (1888) pp. 643–62.

† Arch. f. d. Gesammt. Physiol. (Pflüger) xliii. (1888) pp. 71–151.

it, just as much as in freely living animals, the firm substance increases considerably at the expense of the watery; the inorganic constituents take but a very small share in this increase. At the beginning of development there are formed tissues which are very rich in water, and this richness of water steadily diminishes as development goes on. The substances soluble in water are so disposed that their absolute quantity increases with increasing development, while their relative quantity (as compared with the other constituents) diminishes. It is just the reverse with the constituents which are soluble in alcohol. The fatty matters undergo considerable increase. The quantity of albumens and albuminoids which are insoluble in water absolutely increases as development goes on, but relatively the quantity remains almost unchanged.

Among other points dealt with by the author are the presence of mucin, the quantity of hæmoglobin, and the composition of the embryonic feathers and of bone as compared with those of older forms.

### B. Histology.\*

Cell-Studies.†—Herr T. Boveri believes that the course of karyokinetic division may be generally described in the following terms:—The chromatic nuclear material becomes collected together into a definite number of isolated pieces of a form characteristic of the kind of cell—the chromatic elements; an achromatic filamentar figure is formed into two poles, either from the substance of the nucleus or from that of the cell. The chromatic elements, so far as their number, form, and size allow it, are deposited in the equatorial plane of the achromatic figure; the chromatic elements divide into two halves, one of which makes its way towards either pole; the daughter elements break up in the framework of the new nuclei.

In the ova of *Ascaris lumbricoides* the germinal vesicle has, in the earliest stage, the typical structure of the resting nucleus, and we are justified in supposing that the chromatic elements arise from the framework in exactly the same way as in other cases, though the details cannot be certainly made out in consequence of the small size of the object. The arrangement of the elements in an equatorial plate, their transverse division, and the formation of daughter-plates are effected in just the same way as they are now known to be in other cases, and especially in the ova of Arthropods. The only point of difference is the relation of the daughter-elements which remain in the egg after the expulsion of the first polar globule, for these remain isolated, and so are the direct mother-elements of the next spindle.

In the germinal vesicle of the ovum of *Ascaris megalocephala* (Carnoy's type) two independent portions of chromatin are found in the earliest known stage; though nothing is certainly known of their mode of formation, it may be assumed that they are derived from a typical nuclear framework. This conversion, however, of the reticulum into the chromatic elements, which in other cells and in some ova (*A. lumbricoides*) directly precedes division, appears in most eggs to take a long time. The important difference in the eggs of the type of Van Beneden is that there is but one chromatic element; this seems to be unique.

There are many reasons for supposing that the division of the chro-

\* This section is limited to papers relating to Cells and Fibres.

† Jenaisch. Zeitschr. f. Naturwiss., xxi. (1887) pp. 423-515 (4 pls.).

matic elements sometimes happens at a time when there is no indication of the achromatic figures of division. The most striking of these cases has been lately described by Flemming. Similar phenomena have been observed by the author in the eggs of *Ascaris*. In the germinal vesicle of *A. lumbricoides* the twenty-four rods exhibit the most distinct transverse division, long before the germinal vesicle begins to be converted into the spindle.

After considering several cases in different forms the author expresses his belief that they form parts of a series in the degeneration of the process of nuclear and cellular division. In the case of *Corydalis cava*, described by Strasburger, the process is least rudimentary; two typical daughter nuclei arise, but these again fuse into a single nucleus; in *Thysanozoon* and *A. megalocéphala* daughter stars or plates are formed, but at once pass into a single resting nucleus. In the cells of Flemming and Carnoy there is a division of the chromatic elements, but no arrangement in two groups.

Herr Boveri suggests that in the parthenogenetic eggs described by Weismann as having only one directive corpuscle we have to do with the same process as in the eggs of Ascarids; there are two divisions, but the second is limited to division of the chromatic elements. If this be so, the parthenogenetic development is not to be regarded as dependent on the suppression of the development of the second directive corpuscle, but by its retention in the egg, and the fusion of its nucleus with the ovarian nucleus. The second directive corpuscle may then be regarded as playing the part of the spermatozoon, and it may be said that parthenogenesis is due to fertilization by the second directive corpuscle.

In the achromatic nuclear figure the mode of origin of the spindle, and the complete want of polar rays are of significance. The often discussed question whether the nuclear spindle is derived from the substance of the nucleus or of the cell may, in the case of Carnoy's type of *A. megalocéphala*, be certainly decided in favour of the former.

A number of points in Carnoy's account of the phenomena of maturation of the ova of Nematodes are discussed, and corrections offered.

**Flemming on the Cell.\***—Prof. N. Flemming has been investigating the cellular division in the spermatocytes of *Salamandra maculosa*. He finds that these cells exhibit a remarkable dimorphism of mitosis; in the heterotypical form the chromatic formations exhibit metakinesis. The two forms, the other of which may be called homeotypical, are sometimes found together, but, as a rule, the heterotypical form is found in the first multiplication of the testicular epithelium after fecundation (April or May). In both types the chromatic filaments undergo a longitudinal division. All the differences, it should be remarked, presented by mitosis, whether in spermatocytes or other kinds of cells, are simple peculiarities of form and aspect, and are in no way fundamental. In the heterotypical form the extremities of one pair of divided filaments unite in the same way as in the egg of *Ascaris megalocéphala*; the united parts are, later on, placed at the equator, and when they become definitely separated, one might believe that the separation of the loops was effected transversely, whereas it is due to longitudinal division.

\* Abstract in Arch. Zool. Expér. et Gén., v. (1887) pp. xxxiii.-v. Original source not cited.

Finally, a second longitudinal division of the filaments takes place in the daughter-cells during the *Diaster*-phase.

In the homœotypical form the divided filaments, after separating from one another, during metakinesis, remain for a long time in the region of the equator. The appearance of the figures might lead to the erroneous opinion that there had been no longitudinal fission of the filaments.

The number of primary segments is, in both types, only half of that which it is in the mitosis of other kinds of cells of *Salamandra* (twelve instead of twenty-four). All the differences are reduced to one chief fact—the prolongation of the process united to a special form of metakinesis, that is to say from that phase in which the unfolded segments separate from one another to form the two groups of daughter figures. These special forms are found, with very similar characters, in the egg of *Ascaris* (according to Van Beneden), and probably (according to Carnoy) in the spermatocytes of Arthropoda. As yet they have only been found in sexual cells.

These observations throw light on the remark of Carnoy that the characteristic phenomena of karyokinesis are variable and that no case appears to be essential. It is possible that in the small spermatocytes of Arthropods the first longitudinal division of the filaments escaped Carnoy's notice, and so led him to a generalization which Flemming shows to be inexact.

**Cell-division.\***—Dr. T. Schottländer reports the results of his researches on nuclear and cell-division in the endothelium of the inflamed cornea. His principal conclusions are as follows:—

(1) In some cases irritation of the frog cornea by chloride of zinc simply causes rapid decomposition of the endothelium. This happens with prolonged irritation, or with weak animals. (2) With moderate irritation and strong animals certain changes are seen from the second day onwards, which seem to be progressive, and doubtfully suggest amoeboid movements of the cells, or direct segmentation, or direct fragmentation. (3) From the seventh day the mitotic changes of regeneration begin, and continue till the fifteenth day.

(4) The mitoses are for the most part typical. The anaphases are remarkable for the splitting of the achromatic connecting threads, which appears to mark the completion of division, and recalls the cell-plate formation in plants. (5) Various abnormal cellular figures occur, especially characterized by varied disposition of the chromatic loops. (6) Multiple nuclear division rarely but really occurs, both in regular fashion and with certain irregularities of procedure. (7) Among the deviations from the typical mitosis must be noted certain figures which may possibly represent indirect fragmentation.

**Karyokinesis and Heredity.†**—Prof. W. Waldeyer has lately published a series of papers on the phenomena of karyokinesis and their relation to the problems of heredity. He confines himself for the most part to a summary of past researches, in which the results and divergences of Hertwig, van Beneden, Nussbaum, Carnoy, Weismann,

\* Arch. f. Mikr. Anat., xxxi. (1888) pp. 426-82 (1 pl.).

† 'Ueber die Karyokinese und ihre Bedeutung für die Vererbung,' Leipzig, 1887.

and Zacharias are stated and criticized. Naturally much space is devoted to a discussion of the much disputed question of the behaviour of the pronuclei.

**Cellular Statics.\***—Prof. L. Errera has investigated the statics of cell-form, comparing them with soap-bubbles. It is interesting to notice that in the same year (1887), Leblanc, Fuchs, Errera, and Berthold were independently at work on the same problem.

At the moment of appearance the cell-membrane is extremely thin, delicate, plastic, and changeable in its particles. Like similar fluid lamellæ, it tends to assume that form which would be taken by a weightless fluid lamella under the same conditions, and to exhibit a minimal surface and constant curvature. Apart from the mere shape of the cell, questions of division, wall-formation, and the like are discussed in a suggestive way. Even the thirteen conclusions, however, involve technicalities which hardly admit of compression.

**Fusion of Lymphatic Cells into Plasmodia.†**—M. A. Michel does not accept the explanation of Mr. Geddes, by which the fusion of lymph-cells of *Lumbricus* is compared to that seen in *Myxomycetes*. The lymph when first collected contains a large number of flattened branched cells; after a few minutes' exposure to the air these become spherical in form, with pointed projections; some elongate and ramify into protoplasmic prolongations, which constantly change their form, especially if placed in a warm chamber at 30°. In about half an hour these cells form a plexus; there is a gradual concentration. At the end of two or three hours there are only rounded masses with peripheral prolongations. The free cells give out a transparent protoplasmic layer which is often much vacuolated and of such delicacy that its boundaries can only be made out with difficulty; some of the cells meet and form a continuous layer with spaced granular centres, each with a nucleus, or they form fine complicated or amœboid plexuses. Finally, the masses die at the end of some hours, and break up into rounded elements, each of which has its nucleus.

The author points out that, even in the warm chamber, the living masses have no general movements; the only changes which occur are due to the general contraction and rupture of very extended filaments. If isolated moving cells are carefully followed it will be seen that, among the massed cells, some will separate from and leave the fused mass. These masses, when observed with a high magnifying power, do not present the homogeneity which would be exhibited if the fusion were real. The circular striæ which may be noticed suggest that there has been a tangential displacement of imprisoned cells. The best results are obtained with the vapour of osmic acid, and staining with picro-carminate of ammonia; chromo-nitric liquid (Perenyi's fluid) shows the distinct cells with their nuclei.

In addition to the objections raised by these considerations, the author points out that death occurs successively at different points, and that each element may be made to swell by water into an agglomeration of vesicles pressed one against another, and he concludes that the fusion of the cells is only pseudo-plasmodic.

\* Biol. Centralbl., vii. (1888) pp. 728-31 (60 Versamml. Deutsch. Naturf. Wiesbaden, 1887).

† Comptes Rendus, cvi. (1888) pp. 1555-8.

**Secreting Cells of Intestinal Epithelium.\***—Herr J. Paneth has made a detailed investigation of the histology of the secreting cells of epithelium of the small intestine. The subjects of research were mainly newt and mouse. By far the fittest staining reagent was safranin, used after Pfitzner's method.

His chief conclusions are as follows:—

The goblet cells of the small intestine arise from ordinary epithelial cells. The secretion appears first in the form of granules. A portion of the protoplasm and the nucleus persist but undergo certain changes. If a reticulum be found in the theca of these goblet-cells, it is not protoplasmic, but consists of secretion. After the secretion is emptied, the goblet-cell becomes again epithelial.

In the crypts of various mammalian intestines, secreting cells occur which are neither goblet-cells, nor mucous, nor pancreatic. They lie at the bottom of the crypts, and are filled with granules of variable, and often large, size.

**Spinal Ganglion-cells.†**—Herr H. Daae has investigated the spinal ganglion-cells of mammals, and especially those of the horse. His chief results are as follows:—The spinal ganglion-cells of the horse are so far unipolar, since each cell is associated with one large nerve-fibre. But only in some cases is this process undivided. Often it divides within or outside the capsule into many thin medullary fibres, which may ramify and form by the union of their smaller branches a coil. From this there issue, in variable number, terminal fibres, without medullary sheath, and in connection with the body of the cell. These the author calls "origin fibres." Where only two such origin fibres are present the cells are therefore bipolar, and the poles lie apart. Where there are more than two origin fibres, the cells are multipolar, even though the multiple processes unite into one main fibre. The peculiar ramification and reunion of the fibres in the aforesaid coil appears to have been hitherto overlooked.

**Axis-cylinder and Nerve-cells.‡**—Dr. J. Jakimovitch has investigated, by the silver nitrate method, the histology of the nervous system. His objects of investigation ranged from mammals to fishes, and also included insects. A short summary of the history of past research is prefixed.

The chief conclusions arrived at are as follows:—The axis-cylinder and the nerve-cell are constructed on the same type. The latter is only a nucleated enlargement of the former. Both consist of delicate fibrils and an intermediate substance. The primitive fibrils include two distinct substances; a clear unstained component alternates with a brown-stained material, so as to produce a striated appearance. The stained substance is dense, elastic, and more solid than the clear substance. The two may be separated by maceration, and the primitive fibril is resolved into nervous particles ("particules nerveuses"), which form the primitive elements. They are irregularly disposed in the cylinder and cell in the resting state; but group themselves to form striæ during activity. The striæ are nowise artificial; their state varies after death. The same essential appearances are seen throughout the series.

\* Arch. f. Mikr. Anat., xxxi. (1888) pp. 113-91 (3 pls.).

† Ibid., pp. 223-35 (2 pls.).

‡ Journ. de l'Anat. et de la Physiol., xxiii. (1888) pp. 142-68 (1 pl.).

## γ. General.\*

**Growth by Intussusception.**† — Prof. O. Bütschli discusses the general question whether we must suppose a growth of the plasma by intussusception. He states the well-known theory, and notes its general acceptance, and the recent criticism. Whatever be true of starch-grains and cell-wall, in regard to the plasma itself intussusception has seemed to most the only possible mode of growth. But the modern recognition of the reticular, vacuolate, or webbed structure of protoplasm seems to Bütschli to suggest another possibility. Like others, he distinguishes in the Protozoon body two substances—the web-forming plasma proper, the included more fluid chylema. The existence of such structures makes it quite possible that newly formed plasma molecules are directly apposed to the extremely fine walls of the plasmic web.

**Remarkable Case of Mutualism.**‡ — Dr. C. P. Sluiter describes a remarkable case of mutualism, in which two species of *Trachichthys* (or *Amphiprion*) live with certain large tropical Actiniæ. The fishes swim about between the numerous tentacles, notwithstanding the presence of numerous stinging organs. Here the fishes appear to be safe against the attacks of larger fishes, and they never go far from their hosts. While there can be no difficulty in seeing the advantage to the fish, there is but little in detecting the benefit to the Actinian. The continual movements of the fish bring about an advantageous change of water; and it has been observed that one species brings food to the Actinian.

## B. INVERTEBRATA.

**Blood of Invertebrata.**§ — M. L. Cuénot, after some remarks on the general composition and function of blood, gives a brief account of the results of his observations on various groups. Notwithstanding the statements of Foettinger and Howell, he denies the existence of hæmoglobin in Echinoderms; in them the amœbocytes are almost the only nutrient parts of the blood. In Insects the liquid of the cœlom contains a dissolved albuminoid, varying in colour, which has both respiratory and nutrient functions. In the blood there are a number of typical amœbocytes, which are produced by a large gland which completely surrounds the heart, and even extends over the alæform muscles; this gland is formed of a connective stroma filled with nuclei and fine granulations. These nuclei gradually surround the albuminogenous ferment, and escape from the gland. This lymphatic gland is found in the larvæ as well as in the imagines of all orders of Insects, with the single exception of *Chironomus plumosus*, in which there is hæmoglobin. In Scorpions the lymphatic gland is an elongated body, situated on the dorsal part of the nerve-chain; it seems to be merely a spongy diverticulum of the dorsal artery of the nerve-chain.

In the crayfish, crab, and *Pagurus* the blood-fluid, in addition to its ordinary albuminoids, contains amœbocytes with a yellowish ferment; these are produced by a gland which is situated in the gill, and which is so arranged that the just oxygenated blood traverses it, and carries

\* This section is limited to papers which, while relating to Vertebrata, have a direct or indirect bearing on Invertebrata also.

† Biol. Centralbl., vii. (1888) pp. 161-4.

‡ Zool. Anzeig., xi. (1888) pp. 240-3.

§ Arch. Zool. Expér. et Gén., v. (1888) pp. xliii.-vii.

away the ripe elements that have been formed in it. The gland is merely a connective reticulum in which nuclei are scattered.

In Mollusca the lymphatic gland is generally placed near the respiratory apparatus; in Gastropods it varies considerably in position and relation.

In the Oligochæta the amœbocytes are formed by the so-called hepatic layers of the intestine; in Hirudinea they form the bothryoidal tissue of Ray Lankester; the cells are often of large size, and contain large yellow or greenish granules. The blood of Gephyreans has a remarkable likeness to that of lower Vertebrates, well marked amœbocytes with a yellow ferment and nucleated corpuscles containing a colourless liquid different from hæmoglobin being found in it; in the Tunicata there appear to be two kinds of elements, but they are very different from those of Vertebrates.

**Pelagic Animals at Great Depths and their Relations to the Surface Fauna.\***—Dr. C. Chun has made a number of interesting and important observations on pelagic animals living at great depths, which are reviewed by Prof. Alexander Agassiz.† From a depth of 1300 metres Dr. Chun brought up a large pelagic fauna; small ceraspode Medusæ, Ctenophores, Tomopteridæ, *Sagittæ*, Alciopidæ, larvæ of Decapod Crustacea, *Appendiculariæ*, Pteropoda, and small transparent Cephalopods. Dr. Chun assumes that there were no currents at the spots whence he obtained his rich hauls, but Prof. Agassiz thinks there is nothing to show that when so near the shore as he was there is not a more or less active interchange of the fauna from the shore slopes to that of greater depths. If a deep-sea pelagic fauna should be found in the deep water of oceanic basins it would help to explain the manner in which the deep-sea fauna obtains its food. Prof. Agassiz thinks that Chun's results merely prove that in a close sea (the Mediterranean) near shore there is, even at considerable depths, a great mixture of true deep-sea types and surface pelagic animals which sink at certain times far beyond the limits usually assigned to them.

Many of the so-called surface pelagic types have been proved by deep-sea expeditions to be the young of abyssal species. Chun has, however, clearly proved that many embryonic stages of surface pelagic animals are only found at considerable depths. Deep-sea fishing with a properly closing net promises to be a material help to embryological investigations.

Dr. Chun considers that the great increase of temperature at the surface compels surface pelagic animals to seek cooler depths; while allowing this for some groups, Prof. Agassiz thinks that the calm or ruffled condition of the surface is a more powerful influence. It is only on calm nights that a good harvest of surface animals can be obtained. In his own experience of surface collecting Prof. Agassiz "never met with such prodigious masses of surface pelagic animals as on the hottest days of our dredging expeditions. When the sea happened to be smooth as glass under a blazing tropical sun it seemed as if the water was nearly solid as far as the eye could reach with countless surface animals of all sorts."

Prof. Agassiz thinks that there is nothing to show that the more active deep-sea Crustacea, Fishes, Cephalopods, Pteropods, Annelids,

\* Bibliotheca Zoologica, i. (4to, Cassel, 1888) pp. 1-66 (5 pls.).

† Amer. Journ. Sci., xxxv. (1888) pp. 420-4.

Aculephs, Polyps, Rhizopods have not a considerable range, and may pass either vertically or near the bottom through layers of water of very considerable differences of temperature and pressure.

It is to be borne in mind that nearly all the Radiolaria which Dr. Chun took with a tow-net at a depth of 300 fathoms have also been collected at the surface, and the same is true of some other forms. The author seems to have demonstrated for surface pelagic animals a far greater bathymetrical range than they were known to have, and one which, perhaps, corresponds to the wide bathymetrical range of many so-called deep-sea types, which extend from the greatest depths at which animals have been dredged almost to the regions of the littoral belt.

Dr. Chun gives an account of the development of Ctenophora, and shows that the *Cydidippe*-form of *Bolina*, after the degeneration of the genital organs, which are fully developed soon after leaving the egg-envelope, is developed into the *Bolina*-form; this peculiar mode of reproduction he calls Dissogonie.

**Physiology of Nervous System.\***—Herr Steiner has made some experiments on nervous functions among Invertebrates. The cerebral ganglion of the crayfish is shown to be the general locomotor centre. In the leech, however, this is not the case; the removal of the cerebral ganglia made no great difference; even separated portions crept about. In *Pterotrachea mutica*, a conveniently transparent mollusc, the removal of the central ganglion made no difference, but movement ceased with the destruction of the pedal. The latter is the general and the only locomotor centre of the body. One side of the pedal ganglion was removed in the pelagic *Cymbulia*, which then exhibited circular movements on the injured side. Removal of the cerebral ganglion in *Octopus vulgaris* stopped voluntary and spontaneous nutrition, but the reflex action of the eye persisted. The removal on one side of the anterior portions of the sub-oesophageal ganglion led to circular movements as in *Cymbulia*. In *Appendicularia* the tail ganglion is the locomotor centre.

## Mollusca.

### a. Cephalopoda.

**Shell-growth in Cephalopoda.**—Professor J. F. Blake † urges that Mr. F. A. Bather, whose communication has been already noticed, ‡ has added nothing of value to what he himself taught as to the morphology of the shell in the Introduction to his work on ‘British Fossil Cephalopods.’ Mr. F. A. Bather § replies that Prof. Blake now appears to accept the view which it was his object to defend rather than originate—namely, that successive chitinous membranes are given off by the body-surface and subsequently calcified, but that that is not the teaching of the Professor’s monograph. Prof. Blake criticizes the suggestion that the membranes of the septa are typically continuous with those of the shell-wall, but it is urged that not only are the two descriptions that he gives inconsistent with one another, but both are in disagreement with the facts of the case. Objection was also taken to the assumption that the lamellæ of *Sepia* are homologous with the septa of a Belemnite-phragmocone, but this is an old view first taught by Voltz in 1830, held by many first-rate observers, and supported by original observations on Mr. Bather’s part.

\* Biol. Centralbl., vii. (1888) pp. 732-3 (60 Versamml. Deutsch. Naturf. Wiesbaden, 1887).

† Ann. and Mag. Nat. Hist., i. (1888) pp. 376-80.

‡ *Ante*, p. 397.

§ Tom. cit., i. (1888) pp. 421-7.

**Spermatozoa of *Eledone moschata*.**\*—M. A. Sabatier finds a double method of spermatogenesis in *Eledone moschata*, comparable to that already observed in some Gastropods by MM. Kochler and Robert. In one set, the head is formed by a fine, very regular spiral; in the other kind, the head, which is much longer, is a simple straight or very irregular sinuous filament. In the spermatoblasts which give rise to the spiriform spermatozoa the chromatin of the nucleus is condensed at the centre of the cell into a mass which is at first globular, but soon becomes club-shaped. The nuclear membrane becomes invisible, and the chromatic rod is situated at the centre of the cell, which also becomes elongated. The cytoplasm which surrounds the rod becomes very delicate, and becomes largely aggregated round the thinner end of the club-shaped body. The thicker end of the latter frees itself from the body of the cell, and gets at its end a very fine colourless filament which appears to be formed by the elongation of part of the cytoplasm; this is the tail of the spermatozoon. As the rod elongates it becomes more and more delicate, till at last its massive form gives place to a spire with regular turns, which are at first close, and gradually separate from one another.

The filiform spermatozoa are developed after a different fashion. The chromatin of the spermatoblasts becomes condensed at the periphery of the nucleus, close to the nuclear membrane. It is at first an arc which elongates as it grows. The cell becomes ovoid, and the chromatin narrows at one extremity, which carries a mass of granular protoplasm. The remainder remains rolled round a clear, spherical mass; it next elongates and loses its spiral form, when the spermatozoon appears as a chromatic filament with a very long tail, and attached by its base to a mass of granular cytoplasm, which, in its turn, disappears.

M. Sabatier's observations on *Eledone* have confirmed him in the opinion he long since expressed that the vermiform spermatozoa of *Paludina* are true colonics of spermatozoa, corresponding to a group of spermatozoa, the heads of which have become fused, while the tails have remained distinct.

#### β. Pteropoda.

**Musculature of Heteropoda and Pteropoda.**†—Herr G. Kalide has investigated the musculature of the Heteropoda and Pteropoda with the view of throwing light on the morphology of the foot of Mollusca. In the former the musculature of the trunk consists of two muscular strata lying one above the other; the fibres of the upper layer pass from above forwards to below backwards, and those of the lower layer from below forwards to above backwards. In the caudal region, the visceral sac, and the proboscis, this musculature has a longitudinal direction. Above it there is a circular muscle which covers the greater part of the body (*Carinaria*), or is limited to the proboscis (*Pterotrachea*). The fin has its own musculature, which is connected with the spindle-muscle. The author thinks that sufficient attention has not been given to the fact that the musculature of the fin has no connection with that of the trunk, while that of the anterior processes of the body passes continuously into the trunk. If the fin of the Heteropoda be homologous with any part of the body of any other Mollusc, that part must have a similar arrange-

\* Comptes Rendus, cvi. (1888) pp. 954-6.

† Zeitschr. f. Wiss. Zool., xlvi. (1888) pp. 337-77.

ment of its muscular fibres. In this connection an investigation must be made into the morphology of the Pteropoda; in them, too, there is a great differentiation of the foot, leading to the formation of two laterally placed fins—the epipodium of Huxley—and, in some, to the distinction of a horseshoe-shaped and a conical piece in the median part of the foot. As in Heteropods, the fin-musculature of Pteropods is formed by rays from the spindle-muscle; by this character and by the independence of the whole fin-musculature of the musculature of the body, the fins of Pteropods are shown to be homologous with those of Heteropods.

It has not yet been demonstrated that these fins are derived, ontogenetically, from the foot. The protopodium of all Molluses is a mere outpushing of the body-wall into which the cœlom is merely continued. In the Heteropoda this protopodium is separated from the body by the caudal portion and carried backwards. This caudal portion is a structure quite similar to the protopodium, in so far as it is a mere prolongation of the body-wall, although filled by gelatinous material. The intercalation of the caudal portion may be regarded as due to the growth of the tissue at the base of the protopodium, and this region may be looked upon as part of the organ which corresponds to the developed protopodium. If this be so, there is nothing surprising in the musculature of the body passing directly into the tail. The arrangement of the muscles of the fin seem to show that it is not a differentiation of the protopodium, but a formation *sui generis*. While we regard the tail as an outgrowth of the body, due to local growth, the fins of Heteropods and Pteropods must be looked upon as an outgrowth of the spindle-muscle, or of a part thereof; the body-wall having been broken through in such a way that the newly-formed structures are only accompanied by the epidermis and the gelatinous cuticle.

When we ask if there is in Gasteropods or Lamellibranchs any organ homologous to the fins of Pteropods or Heteropods, we find that in them, as in all Molluses save Cephalopods, the first rudiment of the foot is the protopodium, which is the only differentiation on the ventral surface of the embryo. No other differentiations appear, or, in other words, there is no deutopodium.

#### γ. Gastropoda.

**Abnormal Growth in *Haliotis*.**†—Mr. E. A. Smith gives a description of an example of the Japanese *Haliotis gigantea*, which is remarkable for having two rows of perforations in the shell instead of one. Four of the holes of the outer or normal series are open, while all those of the inner series are closed or filled up. Mr. Smith supposes that the edge of the mantle at this particular point was accidentally notched in early life (or from congenital defect), and that the notch was not deep. It is probably correct to suppose that the perforations are for the purpose of conveying water to the gills, and to some extent, for the extrusion of fœces. As there are neither gills nor anus beneath the abnormal series of holes, they had no special function to perform, and so became closed up as soon as possible. In figures of *H. tuberculata* given by Cuvier and by Fischer a tentacle may be seen to be protruded through each of the last six or seven perforations; in no specimen or species examined by Mr. Smith are there ever more than three tentacles, and these are always similarly located.

\* Ann. and Mag. Nat. Hist., i. (1888) pp. 419-21.

*Testacella*.\*—Prof. H. de Lacaze-Duthiers has published an interesting memoir on this Gastropod. Altered though its organization may be, and displaced as are some of its organs, it is still possible to associate it with the rest of the Pulmonata. Though the mantle and shell are very small they both remain as evidence of the parts which are so well developed in allied groups. The only portion of the body which they protect is the true respiratory cavity.

The details of anatomical peculiarities may be largely explained by the drawing down of the mantle and shell, and the elevation of the liver and the organs of reproduction. These two fundamental modifications are the cause of others which are no less important. Thus, when the organ of respiration, which is always intimately connected with the central organ of circulation, changes its place, the heart invariably follows it, and comes to occupy such position as the lung leaves free for it. The same thing happens to the kidney, which is always attached to the pericardium. As a rule the marginal folds of the mantle are quite close to the head, which they often protect, and in consequence of this, the pallial nerves are short. But in *Testacella*, the mantle is separated from the head, and consequently from the nerve-centres; the pallial nerves are, therefore, of greater length, though they preserve their fixed relations. Long and delicate nerves, such as those of the foot, float in the general cavity, and are only recognizable by their origins and insertions. "The connections of the nervous system are so constant and imperative, that to follow a nerve is to take in hand the thread of Ariadne which guides and conducts us to the part which it is required to determine, and which, at first, might be misunderstood, in consequence of the transformation it has undergone."

The same is true of the arteries. The heart being removed to the lower part of the body, the organs which have in consequence been displaced, have, so to speak, carried the arteries with them. A very interesting relation is presented by the passage across the cesophageal collar of the termination of the ascending aorta. The pedal artery, crossing above the pedal ganglia, ought to pass in front of them to redescend and nourish the foot as far as its lower extremity. This is a constant arrangement in the Pulmonata, but in *Testacella*, owing to the length of the course which it has to take, the aorta gives off an accessory branch at the middle of its length, which opens freely with the true pedal vessel, and so makes up for the insufficiency of supply which is due to the too great length of the latter. Here there is deformation due to elongation, but the relations are fixed, and the parts, modified though they are, have been able to preserve this same relation.

The superiority of the value of characters which are drawn from connections over those furnished by diversity of forms and deviations from the normal is shown by the relative position of the heart and lung in the economy of *Testacella*. The fixed connection of the two organs is seen in the connection between the auricle and the efferent vessel of the lung, but the relative position of the two, as regards the rest of the body, depends on changes effected in the body in consequence of the displacement of some of the viscera.

Whatever be the cause of the change which it has undergone, we cannot but recognize that *Testacella* is atrophied in some of its parts and disproportionately developed in others. As compared with a slug, we

\* Arch. Zool. Expér. et Gén., v. (1887) pp. 459-596 (12 pls.).

see that the mantle is in both rudimentary, and has become unable to secrete a shell sufficiently large to form a protection for a whorl of viscera. In the slug, the mantle retains its dorsal position, and is at about the middle of the axis of the body; in *Testacella* it is terminal and ventral. In the slug the viscera pass into the foot, in *Testacella* into the neck; but in both the distribution of the nerves enables us to establish the true nature of the parts which have been modified to the purpose of new functions, and which have become irrecognizable. In conclusion Prof. M. Lacaze-Duthiers urges that, if modifications in the position of some organs can change the general physiognomy and external appearance of an animal, it is no less true that we ought not to regard their displacement as affording a criterion of the highest value for the characterization of classificatory divisions. Although the heart and lung are altered in relation to the whole, they are not altered in their relation to one another; the heart is always intercalated between the body which it has to nourish, and the lung from which it draws its freshened blood. In so natural a group as the Pulmonata it is sometimes behind, sometimes beside, sometimes in front of the lung, but its absolute position does not alter. The corollary from this is that classifications based on the relative situation of lungs and heart ought to be revised.

**Absorption of Water.\***—Herr A. Fleischmann returns to the old question of the taking in of water by molluscs. The affirmative position maintained by Delle Chiaje was supported by the observations of Kollmann and Griesbach; criticism has, however, weakened the latter, but the recent researches of Schiemenz † seem to settle the question definitely. To the latter and to his own investigations the author refers.

Schiemenz has described with great definiteness the water-pores found on the foot of *Natica josephina*. They are minute ( $7-8\mu$  in maximum diameter), below them strong closing muscles are aggregated, from them minute cavities extend into the foot. As to the physiology, Schiemenz sets aside any mixture of water and blood, declares the vascular system of *Natica* to be closed; the elements of the foot (muscles, nerves, glandular cells) are all inclosed and protected from the water by a limiting membrane which surrounds vascular lacunæ. The membrane also extends below the epithelium, and gives off protrusions including blood-sinuses between the epithelial cells.

The water is taken in as follows:—the vessels of the foot are richly filled with blood; the muscles become tense; cavities are left between them, and into these the water enters. When a sufficient quantity has passed in, the closing muscles shut the pores, the animal moves with its tense foot.

Schiemenz has also noted, in another case, the modifications produced in the blood by the introduction of water, and concludes that where the vascular system and the histological system are not inclosed, there can be no entrance of water.

With the results reached by Schiemenz, Fleischmann entirely agrees. He refers to the researches of Roule and Grobben, which go against the existence of pores, and believes that in most cases the blood and the vascular sphincters are of themselves sufficient to explain the erection of the foot. He maintains as before, in spite of Roule's denial, the certain existence of the "Keber venous valves."

\* Biol. Centralbl., vii. (1888) pp. 713-7.

† MT. Zool. Stat. Neapel, vii. (1888) pp. 423-72.

δ. Lamellibranchiata.

Lamellibranchiata without gills.\*—M. P. Pelsencr has been able to confirm the remarkable observation of Mr. Dall that *Cuspidaria* has no gills. On raising the mantle one finds oneself in the presence of a muscular surface which Dall regarded as the body-wall. This surface is a partition which separates a dorsal from a ventral chamber; it is traversed by the foot, and extends from one adductor to the other; on either side it is connected with the mantle, which is continuous along its whole length; posteriorly it is connected with the partition which separates the two siphons. The visceral mass is found in the dorsal chamber. The labial palps are present, but are very small.

The study of the allied genera *Lyonsiella*, *Poromya*, and *Silenia* has resulted in the unexpected discovery that the muscular septum is a modified gill. In *Lyonsiella abyssicola* the gills are united to the mantle, fused with one another behind the foot, and then joined to the division between the two siphons; but the structure of the gills is preserved. In *Poromya* there is a similar partition, but this is muscular; on either side, however, there are two groups of branchial lamellæ, separated from one another by clefts which allow of a communication between the two pallial chambers. In *Silenia* the reduction is still greater, for the branchial lamellæ have disappeared, and the clefts have become arranged in three separate groups. In *Cuspidaria* reduction is brought to an extreme. M. Pelsencr proposes to form a separate group for the last three genera, and to call it the Septibranchia; *Cuspidaria* must form the type of Dall's family Cuspidariidæ.

So-called Eyes of Tridacna and Occurrence of Pseudochlorophyll Corpuscles in the Vascular System of Lamellibranchs.†—Herr J. Brock gives an account of the so-called eyes which aid so largely in giving a splendid coloration to the margins of the mantle of living species of *Tridacna*. They form an irregular row of differently coloured points, and look like gems. The method employed by Vaillant did not permit him to successfully investigate the minute structure of these organs.

The larger wart-like elevations which are found at some distance from the margin of the mantle agree in structure with the mantle itself. In the warts, however, there are a few peculiarly constructed minute organs which might be taken for eyes. These bodies are flask-shaped, and have their long axis perpendicular to the surface of the epithelium; the whole organ is surrounded by a thin membrane in which fusiform nuclei are scattered. Within are large cells, also with a distinct membrane, and containing clear, and probably highly refractive protoplasm. These transparent cells are surrounded by a layer which is characterized by its great irregularity, and the component cells of which contain coarsely granular protoplasm. No nerve was in any case seen to pass to a flask-shaped organ.

The author is unable to make any suggestion as to the function of these organs, but he thinks it may be confidently asserted that they are not optic. It is much more probable that they are luminous organs; if the cells of the outer layer have the faculty of shining, the more transparent inner cells may act as prisms. The only bodies which can be

\* Comptes Rendus, cvi. (1888) pp. 1029-31.

† Zeitschr. f. Wiss. Zool., xlvi. (1888) pp. 270-88 (1 pl.). Transl. Ann. and Mag. Nat. Hist., i. (1888) pp. 435-52.

said to resemble them in structure are the so-called eyes on the tentacles of *Cardium*, and these are possibly luminous organs.

All the available interstices of the mantle-margin of a *Tridacna* were found to be densely packed with "green cells" or pseudochlorophyll corpuscles. These, which are certainly true cells, have a distinct nuclear framework, which is very deeply coloured by Grenacher's alumcarmine. The nucleus is ordinarily spherical, but sometimes oblong or reniform, and not unfrequently, especially in alcoholic preparations, strikingly stellate. Increase by transverse division was also observed. There is some reason for believing in the presence of a special (cellulose?) envelope. The green colouring matter is fixed by chromic acid, but extracted by alcohol; it is not generally diffused through the protoplasm, but localized in small round corpuscles, which are distributed through the cells in variable numbers. It was not possible to decide definitely whether the corpuscles are situated in the vacuoles or in the protoplasm, but more probably they lie in the latter. These symbionts are not, as is generally the case, found in the cells of the host, but float freely in the cavities of the system of blood-lacunæ.

The protoplasm of the blood-corpuscles was found to have distinctly separated into two different constituents, a perfectly hyaline part, in which the nucleus was always situated excentrically, and a "protoplasmatic" part which showed a very marked fibrous coagulation. This was observed in all of those specimens which had been treated respectively with chromic acid, alcohol, and osmium. In addition to the ordinary amoeboid blood-cells, there were a few bodies which were very characteristic of the blood; these were rounded, or oval, lobate, or otherwise irregularly formed cells, the protoplasm of which was so completely filled with strongly refractive granules of a fatty nature that no cell-nucleus could be found. These "granule-cells" usually attain twice or three times the size of the ordinary blood-cell, and they often lie close to the walls of the blood-lacunæ, in recess-like depressions. These cells have a very remarkable resemblance to certain cells of the interstitial connective substance of the Pulmonata, which were first described by Semper. It is probable that in both cases the cells have some relation to glycogen, or a glycogen-like compound.

With regard to the much discussed question as to intercellular spaces in the epithelium of Mollusca, Herr Brock states that of his three *Tridacnæ*, the osmium and chromic acid specimens did not present the smallest interstices between the individual cells, while the spirit specimen had the whole epithelium traversed by numerous large typical intercellular spaces. As only one of these can represent the natural condition, the comparative value of the preservative fluids has to be taken into consideration. The author declares against the spirit and the spaces.

**Phylogeny of Lamellibranchs.\***—Dr. B. Sharp submits some considerations on the phylogenetic classification of Lamellibranchs. He regards the entire group as degenerate, as derived from Gastropoda, and as represented in primitive form by forms like *Nucula* and *Trigonia*. The loss of one adductor is referred to mechanical causes. This is followed through *Mytilus* and *Pinna* to *Ostrea*. A passage from regular to irregular shell is to be seen in the fresh-water forms. *Unio* repre-

\* Proc. Acad. Nat. Sci. Philad., 1888, pp. 121-4.

sents a fresh-water *Mytilus*, and a form that closely resembles the oyster can be traced through *Ætheria* to *Muelleria*.

In another direction the author traces development from the central *Arca* types to the extreme of *Aspergillum*. In this procedure, *Lucina*, *Cardium*, *Venus*, *Mya*, *Solen*, *Macha*, *Teredo*, *Gastrochaena*, and *Clavagella*, are discussed.

In the first branch towards *Ostrea*, the fulcrum moves from a position between the two equally large adductors, toward the oral pole of the body. This brought the anterior adductor in a line with the fulcrum and posterior adductor, where, being of no use, it disappeared. In the other direction, development is in the antero-posterior direction, the shell, however, not taking part in the growth until a form is reached where the shell is exceedingly small and the animal protected by a supplementary deposit of carbonate of lime.

**Crystalline Style.\***—Herr B. Haseloff has made some very interesting observations on the formation of the crystalline style in mussels. Acting on the suggestion of Prof. Möbius that the structure in question represented reserve food-material, the author made experiments with *Mytilus edulis*. The structure seems in natural conditions to be almost constantly present. In some specimens, however, which were set apart and starved, the style disappeared in a few days, and that the more completely, the more complete the fasting. The demonstration was completed, however, by re-feeding some mussels of the same set as those in which the style had disappeared; the result seemed to be the re-appearance of the style. Some observations by Hazay agree with those of the author, and the supposition of Prof. Möbius that the crystalline style represents reserve material seems quite justified. Herr Haseloff does not regard it as a secretion, but a chemical modification of surplus food.

## Molluscoida.

### β. Polyzoa.

**Spermatogenesis in *Alcyonella*.**†—Prof. A. Korotneff has studied the development of the spermatozoa in *Alcyonella fungosa*, which seems to be a particularly fit object for the investigation of spermatogenesis. The main steps of the process, which exhibits the well-known stages named by v. la Valette St. George, has been already summarized; but a few other results may be recorded.

Head, neck, and tail develop independently, and are secondarily united. In the sperm of *Ascaris*, the amœboid portion is the much shortened tail, which here is more complex than usual, and includes several fibrils instead of only one. Referring to van Beneden's observation that the fibrils of an *Ascaris* sperm were cross-striped, Korotneff characterizes a spermatozoon as "a free-living, highly specialized muscle-cell."

**Fresh-water Polyzoa.**‡—Dr. K. Kräpelin has monographed the fresh-water Polyzoa of Germany. The part published treats of the morphology and systematic. The history of research is first discussed, then the

\* Biol. Centralbl., vii. (1888) pp. 683-4.

† Arch. f. Mikr. Anat., xxxi. (1888) pp. 334-47 (1 pl.).

‡ Abh. Naturwiss. Hamburg, x. (7 pls.). Cf. Biol. Centralbl., vii. (1887) pp. 724-5.

general facts of colony-forming and classification, in a third chapter the anatomy, in a fourth the conditions of life. The detailed classification and the phylogenetic probabilities form the subjects of the concluding chapters. Herr Kräpelin does not believe in the existence of a continuous phylogenetic series including all modern forms. The stenostomatous genera *Victorella*, *Pottsiella*, and *Paludicella* stand in close relationship; the group of Phylactolamata has arisen from *Paludicella*-like Ctenostomata, starting from *Fredericella*. Among the higher Phylactolamata parallel differentiation may be observed; thus the genera *Lophopus*, *Pectinatella*, and *Cristatella* form each in their way the terminal point of a series. The greatest advances in the phylogeny are marked by the families Fredericellidæ, Plumatellidæ, and Cristatellidæ. The genera *Plumatella*, *Lophopus*, and *Pectinatella* are inseparable, and must all be referred to the family Plumatellidæ. A diagnostic table of the genera is appended.

#### Arthropoda.

**Embryology of Insects and Arachnids.\***—The late Mr. A. T. Bruce, from his observations on the development of Insects and Arachnids, was led to certain views as to the relations of tracheates. He was of opinion that *Peripatus* and the Myriopoda, from the absence of wings and other primitive characters, may fairly be considered the most primitive tracheates. Some Myriopods exhibit indications of a hexapod stage in their development, and they may, therefore, be related to the wingless Hexapods. The mode of origin of the endoderm is not very important for classificatory purposes, as it is very likely modified by the presence or absence of food-yolk. The mesoderm of *Peripatus* grows forwards from an undifferentiated cell-mass at the posterior end of the embryo; the mesoderm arising from the "primitive cumulus" of Spiders also grows forward from an undifferentiated cell-mass at the posterior end of the embryo. But this resemblance must not be taken to indicate any close relationship, for in the Crustacea the mesoderm has a similar mode of growth. In the higher insects the yolk-cells appear to represent the inner layer of the gastrula, and are consequently equivalent to the endoderm of lower forms; the true endoderm is functional only during embryonic life in absorbing the yolk, and takes little or no part in the formation of the digestive tract. In these tracheates the layer which corresponds to the mesoblast of Arachnids and of *Peripatus* has usurped the functions of the true endoderm.

In endeavouring to separate the different divisions of the Arthropod phylum, anatomical characters as well as embryological phases must be taken into consideration. The possession of a single well-developed pair of antennæ, of tracheal invaginations, and of embryonic membranes, together with the existence of a hexapod stage in their development, afford sufficient ground for regarding Myriopods as lowly-organized or degenerate Insects. *Peripatus* perhaps belongs to the same category, but its embryonic membranes do not appear to correspond fully to those of Insects. Arachnids, in all probability, never possessed antennæ, for all their appendages, like those of *Limulus*, are at one period post-oral, and are not innervated by the supra-cesophageal ganglion.

\* 'Observations on the Embryology of Insects and Arachnids,' 4to, Baltimore, 1887, 31 pp. and 6 pls.

The antennæ of insects are shown by their innervation to correspond to the first pair of crustacean antennæ; the bilobed upper lip of insects is innervated from the second division of the supra-oesophageal ganglion which forms part of the circumoesophageal commissure. In the Nauplius-stage, the second pair of crustacean antennæ is innervated from the circumoesophageal commissure, and a comparison may fairly be drawn between the paired upper lip of Insects, and the second pair of crustacean antennæ. Mr. Bruce regards the antennæ of the Insecta and Crustacea as probably homologous structures which ally the two groups.

The amnion of Insects and Arachnids is probably homologous and allies the two groups, but they and the Crustacea may not have arisen one from the other, but each independently from a common source. The tracheæ of Insects and Arachnids are probably analogous, not homologous, structures; this may be concluded from the fact that the tracheæ of the latter are derived from the lung-books, which are involuted appendages.

#### a. Insecta.

**Polypody of Insect Embryos.\***—Prof. V. Graber considers that the abdominal appendages which are found on the germinal stripe of various Insects, and which in their mode of development, completely resemble the typical or thoracic legs, are homologous with them. These embryonic abdominal appendages have been most accurately observed in certain Orthoptera, such as *Gryllotalpa*, *Mantis*, and *Blatta*, Neuroptera as *Neophalax*, and Coleoptera as *Hydrophilus* and *Melolontha*. In most cases they are only found on the first segment of the abdomen, but in some forms they are also found on the second, and even (in rare cases) on the third. *Melolontha* is the only form in which they have been found on all except the last two or three segments, but it is not improbable that polypody, or, better, pantopody obtains in *Hydrophilus* and the Bee.

The abdominal appendages are always unjointed, and, as compared with the thoracic, quite rudimentary; those of the first segment appear simultaneously, or almost so, with those of the thorax, but the others, when developed, only appear later. With the possible exception of the appendages seen by Kowalevsky in Lepidoptera, they are all confined to the embryonic period. Even within this the length of their existence varies considerably, and the hinder appendages are very transitory. The extent and mode of development of the first pair also vary a great deal; they may either undergo a gradual reduction, or be converted into flat saccules filled internally by loosely arranged cells, which, by constriction at the base, become attached to the body by a hollow stalk. In most cases the saccules are only one-third of the length of the legs, but in the Cockchafer they cover nearly the whole of the ventral surface.

The conditions under which these organs appear make it probable that they are merely the remnants of appendages, or, in other words, that Insects (or Spiders) are derived from ancestors which had well-developed extremities of definite function on their abdomen. These organs were probably all similar, but it may have been that, in adaptation to definite conditions of life, the saccules had the function of gills, or, in other words, the ancestors of Insects and Spiders may have been heteropodous, and been allied to the Crustacea that have posterior branchial sacs.

\* Morphol. Jahrb., xiii. (1888) pp. 586-615 (2 pls.).

**Dermal Sensory Organ of Insects.\***—Dr. O. vom Rath has published *in extenso* an account of his observations on the dermal sensory organs of Insects, the preliminary notice of which we have already reported.† As to the physiology of these organs little is definitely known, and as the structure of the various organs is essentially the same, nothing can be concluded therefrom. The most important position is that of the antennæ; here we find sensory hairs, cones, and membranous canals. With most authors, Dr. vom Rath thinks that the olfactory sense is located in the sensory cones, and perhaps also in the membranous canals, and that the hairs have a tactile function. The function of the canals appears to be one which is well developed in a few Insects only, as they are only occasionally present; where they are found they are present in large numbers; it is not likely that they are of an auditory nature, and it is more probable that they serve for the perception of definite odours, or fulfil an unknown function.

It is only in rare cases that it can be definitely asserted that there is an orifice at the anterior end of the cones, and this point seems therefore to be of little physiological significance. The chitin at the anterior end of the cone is in any case thin and pale, and is probably affected by chemical and physical influences; treatment with dilute potash easily dissolves the chitinous membrane, when the cone is laid open. Where the cones stand in chitinous pits and do not reach the surface we cannot suppose that there is any tactile function, but rather an olfactory. If this be so, and if there are different kinds of cones, we may suppose that these have somewhat different functions. It is possible that some serve for the perception of the feeble odours of distant objects, and others for those that are nearer.

On the palpi cones and hairs are alone found; Leydig was certainly justified in declaring that their anatomical structure shows that the palpi have the same or similar functions to the antennæ. Dr. vom Rath believes that the cones are olfactory organs, and probably perceive not-distant odours. The cones on the maxilla, labium, epipharynx, and hypopharynx seem to be gustatory organs.

**Sub-aquatic Respiration.‡**—Herr E. Schmid has studied minutely, in *Donacia crassipes*, the mode of breathing to which Siebold called attention as common among the larvæ and pupæ of beetles, i. e. extracting air from the air-passages of submerged water-plants.

Pupa-cases, found by him attached to the roots of the water-lily, were observed to be filled with air. A hole in the side of the case next the root corresponded exactly to a deep canal passing through many of the air-passages of the root. This canal had evidently been bored by the insect, and the consequent pressure had caused the air to pass into the cocoon. The larvæ have two main tracheal trunks opening into two sickle-shaped chitinous appendages on the abdomen. These appendages are used, apparently, for boring into a plant so as to allow air from its air-passages to pass into the tracheæ of the insect. When the insect escapes from the cocoon it is borne to the surface by the air surrounding it and imprisoned in the hairs on its ventral surface.

The same mode of breathing may be observed in the genus *Hæmonia*.

\* Zeitschr. f. Wiss. Zool., xlv. (1888) pp. 413-54 (2 pls.).

† See this Journal, *ante*, p. 210.

‡ Entom. Zeitschr., xxxi. (1887) pp. 325-34. Cf. Naturforscher, xxi. (1888) p. 193.

A butterfly—*Paraponyxa stratiolata*—fills its cocoon with air, probably in the same way, for the leaf to which it is attached is often pierced with numerous canals.

**Dorsal Appendages.\***—Miss A. M. Fielde reports finding at Swatow, in still pools of fresh water, an insect or insect-larva which bore on its back four longitudinal rows of jointed appendages, of nearly the same length as its body, and capable of being raised, lowered, or bent, either by the insect or by external pressure. The colour varies with the habitat from pale green to black. The head is flat, with a pair of large eyes made up of six ocelli; the antennæ are short and six-jointed, and the biting mouth-parts strong and horny. The three thoracic segments bear three pairs of six-jointed legs ending in a long claw. The abdomen has nine segments, the last bearing ventrally a pair of long, sharp, jointed styles.

The body is cylindrical, tapering posteriorly, with the ventral surface flattened. All the segments except the last bear dorsally four tapering jointed tubes. The main tracheal trunks run, one on each side, between the proximal ends of these two rows of appendages, through which they send long straight branches.

**So-called Digestive Stomach of some Ants.†**—Prof. C. Emery has examined the stomach of most genera of Camponotidæ and Dolichoderidæ, as well as several Cryptoceridæ, and some members of other groups. In the first of these the crop is succeeded by the calyx, in which are four calycinal lamellæ, held together by a continuation of the crop. Further back are valves, and still further back there is an enlargement. Between this apparatus and the chyle-intestine there is a narrow tube which ends in the latter by a knob. Between the four lamellæ the intermediate membrane forms four folds which project into the lumen of the cup; at the open concavities of the folds are the bundles of longitudinal muscles. The whole is surrounded by the circularly arranged transverse musculature. In every section of a lamella we may distinguish a median portion and two wings; the former contains a groove, which is sharply limited externally, but seems internally to lose itself gradually on the wings. In these two layers may be recognized, the outer of which, as well as the wall of the groove, should be regarded as the continuation of the chitinous membrane of the crop; the striation which is observed is the expression of fine pore-canals. The inner layer of the wings is formed by small very closely packed chitinous hairs. In the valves there are clefts, and these the author looks upon as the continuation of the clefts which connect the groove of the lamellæ with their free surface; there is no homologue of the wings in the region of the valves. The musculature of the stomach, which has been correctly described by Forel, consists of longitudinal and transverse bundles; the latter form a powerful system of constrictors: the greater part of the longitudinal bundles are continued on to the crop, and become lost in its muscular network.

After describing a number of forms, the author proceeds to discuss the morphology and physiology of what should be called the pumping stomach. In the Camponotidæ and such Dolichoderidæ as have a "conical bell," the organ consists of parts which have two different

\* Proc. Acad. Nat. Sci. Philad., 1888, pp. 129-30 (1 pl.).

† Zeitschr. f. Wiss. Zool., xlv. (1888) pp. 378-412 (3 pls.).

functions. By the action of the muscles of the crop the entrance to the stomach is closed, so as to stop the flow of the contents of the crop to the bell or enlargement; by the pressure of the transverse musculature of the stomach the contents of the enlargement are emptied into the chyle-intestine, while the return into the crop is prevented. In the *Dolichoderidæ* and *Plagiolepidinæ* the closure in both cases is effected by the valves. The longitudinal musculature is only found in such stomachs as are not elongated or too compressed; in many of the *Dolichoderidæ* the stomach is very short, and there is no longitudinal musculature at all.

The primitive type, from which the various forms of stomach have been evolved, may be imagined to have been an elastic chitinous tube, provided with four longitudinal folds, and surrounded by longitudinal and transverse muscles; the primitive function was probably the peristaltic contraction of this musculature, by means of which an incomplete pumping action was effected. The genus *Dolichoderus* is a very lowly differentiated form, but a more indifferent stage is found in the *Poneridæ* and *Myrmicidæ*, where the crop is continued backwards into a cylindrical or conical tube, from which the longitudinal muscles appear to be wanting.

The author gives a phylogenetic table, in which is exhibited his view of the relationship of the genera he has examined.

**Senses of Ants.\***—M. Aug. Forel, in an appendix to his former memoir, first corrects an error in regard to the absorption of the ultra-violet rays, and then cites two recent works which confirm the conclusions previously arrived at by him.

Mr. G. W. Peckham affirms, after numerous experiments, that wasps do not hear, but that they have memory and a sense of smell, and that they possess no such mysterious instinct of direction as is indicated in the terms "bee-line" and "wasp-line." If they are far away, they can only find their nests by seeking for them. Handl maintains, with Forel and in opposition to Graber, that animals do not perceive colours by their skin.

Finally, M. Forel gives an account of a series of experiments made by him upon ants. These have led him slightly to modify his former opinion, and to conclude that, though, in general, they use both senses, and are entirely lost without their antennæ, without eyes they may succeed in finding their way back to their nest if the task be not too difficult.

**Parthenogenesis in *Bombyx mori*.†**—Signor E. Verson draws attention to a suggestion ‡ that it might be possible to produce the silkworm parthenogenetically. He points out that this parthenogenetic development does not go further than the formation of the serous membrane. After an experience of twenty years he feels confident that no real parthenogenesis can obtain in the silkworm.

**Karyokinesis in Lepidoptera.§**—Herr G. Platner has studied karyokinesis in the spermatocytes of some Lepidoptera, and bases on it a theory of cell-division. The author believes that the separation of the

\* *Rec. Zool. Suisse*, iv. (1888) pp. 515-23.

† *Zool. Anzeig.*, xi. (1888) pp. 263-4.

‡ By Prof. Krause in the 'Jahresber. über die Leistungen u. Fortschritte in der Ges. Medicin.'

§ *Internat. Monatschrift f. Anat. u. Hist.*, iii. pp. 341-98 (2 pls.).

daughter-elements on the dislocation of the equatorial plate is the result of a circulating streaming; he supposes that the spindle-shaped fibres form a continuous coil, and that a stream of fluid circulates in them in a definite direction. If we suppose that the daughter-elements pass along the fibres and are moved by the stream, it follows that they must separate from one another in opposite directions. The changes in the form and position of the spindles are believed to be the result of the mechanical action of the fluid moving away from the poles. If the asters arise primarily their origin is independent of the direction in which the stream of nutrient fluid traverses the cell, and the spindles are developed at right angles to it. The changes in the position of the nucleus are due to the same cause.

The formation of the coil and the arrangement of the equatorial plate are believed to be the result of protoplasmic streams which traverse the nucleus in a definite direction. The achromatic substance is considered to be the active element in karyokinesis, the phenomena of which cannot be explained by supposing the existence of opposing forces. Division of the protoplasm is looked upon as a purely mechanical process; the constriction and separation of dividing animal-cells being a simple mechanical consequence of the elongation of the nuclear spindle.

**Decrease of Weight in Winter Pupæ of *Pontia brassicæ*.**\*—Herr F. Urech has made a number of elaborate observations on the weight of the pupæ of *Pontia brassicæ*. He finds that this weight steadily diminishes. If the temperature surrounding the pupæ be kept constant, the decrease is increased towards the end of the pupal stage, and especially so a few days before escape; if the temperature be raised moderately, the duration of the pupal stage diminishes; dry air has an abbreviating influence on the duration of this stage.

**Development in Egg of *Musca vomitoria*.**† — Dr. A. Voeltzkow has a preliminary communication on the development of *Musca vomitoria*. The blastoderm is formed simultaneously over the whole periphery of the egg, and no cells remain internally. The polar cells lie at the hinder pole of the egg, and by their presence push the cells of the blastoderm inwards, so that a conical process projects into the interior of the egg. From this cone blastoderm-cells break off, which wander into the interior, and form the so-called yolk-cells; these, in *Musca*, mainly serve to break up the yolk.

The formation of the germinal layers commences with an invagination of the blastoderm on the whole of the ventral surface, and an almost completely closed tube is so formed. The germ-stripes are drawn over on the dorsal surface by the development of dorsal folds. The three layers arise by the constriction and subsequent flattening out of the tubes. The rudiment of the hind-gut now appears as an invagination of the dorsal ectoderm in the hinder third of the egg. The œsophageal invagination does not appear till somewhat later. The amnion is formed simultaneously with the rudiment of the hind-gut, and later on it forms the greater part of the back of the embryo. The polar cells wander on to the dorsal surface, and pass into the hind-gut; their later fate has not yet been made out.

The mid-gut is formed by two lateral thickenings of the endoderm, just behind the blind end of the œsophagus; the lateral pads so

\* Zool. Anzeig., xi. (1888) pp. 205-12.

† Ibid., pp. 235-6.

developed extend, later on, throughout the whole length of the egg. They all grow dorsally and ventrally, and so come to completely inclose the yolk and form the epithelium of the mid-gut. The cœlom is formed by the separation of these pads from the mesoderm.

The tracheæ arise as segmental invaginations, which extend backwards and forwards, and unite into one longitudinal trunk; the segmental invagination-orifices close up. The nervous system arises in three parts, a median invagination of the ventral surface of the ectoderm, and two lateral thickenings.

**Early Stages in Development of Egg of Fly.\***—Dr. H. Henking has investigated the early stages in the development of the fly's egg, with especial reference to free nuclear formation. In the prepared unripe egg the germinal vesicle may be seen as a colourless sphere floating in the egg-contents, which are distinctly coloured by carmine; it has a sharp, simply contoured wall, and contains very fine granules and some clear vesicles, as well as an excentric and distinctly coloured germinal spot, which is provided with vacuoles. The large nuclei of the nutrient cells are very striking, and are very rich in chromatin; these cells and nuclei have almost altogether disappeared from ripe eggs; their chromatin has probably been taken up by the egg-cell. In the ripe egg there is but a rudiment of the germinal vesicle in the shape of a small coloured corpuscle surrounded by a clear space. Only a few observations were made on the polar globules. In most cases of fertilization it would seem that four spermatozoa enter the egg. Nothing definite can be said as to the fate of the female chromatin substance.

The first yolk-cells are formed in two clouds of protoplasm by free cell-formation. The first two cleavage-nuclei appear as clear bodies with an equatorial zone of distinct chromatin filaments; the succeeding divisions follow very rapidly, owing to the number and rapidity of the divisions of the embryonic cells.

By free nuclear formation, the author means all those cases of the formation of nuclei, in which the substance of the mother nucleus does not pass directly, and unaltered, into the daughter-nuclei. The drop-like bodies which are seen in the developing egg must not be called by the same name as the nuclei which contain chromatin, for they have not the same chemical composition. The former have no membrane. The supernumerary spermatozoa break up, and the first primitive nuclei arise in their place. The disappearance of the marginal portions of chromatin, and the formation of a colourless spot is explained by the chromatin having entered into another chemical combination. When there have been chromatin particles formed from the spermatozoa, cleavage-spindle, and yolk, there may arise free nuclei which take part in the conversion of yolk nuclein into nuclear nuclein.

**Development of Aphides.†**—Herr L. Will reports the results of his recent investigation of the important but difficult subject of the development of the viviparous aphides.

(1) *Gastrulation*.—The blastoderm, as the author and Metschnikoff have previously noted, does not overgrow the whole of the surface, but leaves a roundish spot at the lower pole. At the margin of this lower aperture, an active proliferation occurs; the new-formed cells are

\* Zeitschr. f. Wiss. Zool., xlvi. (1888) pp. 289-336 (4 pls.).

† Biol. Centralbl., viii. (1888) pp. 148-55.

separated off, and wander into the yolk and represent the endoderm of the true gastrula. The Aphides thus preserve a primitive character.

(2) *Apical plates and bilateral symmetry*.—The blastoderm thickens at the apical pole to form the apical plate, which mainly gives origin to the brain. Bilateral symmetry is soon established, and is due to differences of growth and to displacement in the outer germinal layer. One half of the blastoderm diminishes greatly to form a thin skin, the *serosa*; the other side thickens greatly, especially in the apical plate. As the thickening increases, the whole portion is markedly shortened, and the apical plate displaced until it occupies the inferior pole of the egg. The result is the establishment of symmetrical halves, and this is soon emphasized by the median division of the plate into two apical lobes.

(3) *The germinal streak and the secondary yolk*.—The appearance of the latter obscures the relations of the former. The secondary yolk penetrates the egg from the outside, but can only do so by the apposition of the still open blastopore against the follicular epithelium, and by its conerescence with the same. In abnormal cases this does not occur, and such ova are most instructive. As in other Bilateralia, the closure of the blastopore seems non-concentric, an inconspicuous elevation over the blastopore forms a short germinal streak. Details are given to show that in extant aphides the germinal streak is established upon the previous blastopore. Will also emphasizes that the secondary yolk does not really affect the endoderm cells.

(4) *Reproductive rudiments and mesoderm*.—Directly after the appearance of the at first cylindrical germinal streak, certain indifferent cells on the thickened side of the germinal cylinder towards the apical plate, increase in size, multiply rapidly, and form the reproductive rudiments. Thereafter the mesoderm is formed by a process of invagination within a groove, along the median line of the thickened side of the germinal cylinder. The formation of endoderm and mesoderm in *Aphis* are two successive stages of one and the same process of gastrulation.

(5) *The embryonic membranes* in these and other insects are to be regarded as modifications of portions of the blastoderm, and of the germinal streak, which were already present in rudiment in pre-existent forms. (6) *Segments and body-cavity*. Transverse grooves are seen in the mesoderm plate, which divides into two lateral strands. These leave the median line free except in the region of the future mouth. The cavities of the segments arise by a folding of the single sheathed mesoderm in consequence of the formation of appendages. They all open medianly. A primary body-cavity arises as a cleft between the blastoderm and the apposed portion of the germinal streak. A secondary body-cavity appears from the above folds, but the details of this can hardly be given. The whole parietal mesoderm is utilized for musculature. The intestinal peritoneum alone remains along with the endodermic fatty body to line the final body-cavity. (7) *The products of the layers*. The endoderm constitutes the mid-gut, part remains in the secondary yolk, the rest forms fatty body and blood. The mesoderm forms the peritoneal sheath of the gut, the heart, and above all the musculature. The ectoderm forms tracheæ, epithelium of mouth and hind-gut, skin, sense-organs, and nervous system.

## γ. Arachnida.

**Mental Powers of Spiders.\***—Mr. G. W. and Mrs. E. G. Peckham have made a large number of observations on the mental powers of spiders.

*Sense of Smell.* Three species (*Argyropeira hortorum*, *Dolomedes tenebrosus*, and *Herpyllus ecclesiasticus*) did not respond to the tests. In all other cases it was evident that the scent was perceived by the spiders.

*Sense of Hearing.* All the Epeirids responded promptly to the tests, being evidently alarmed by the sound of the tuning-fork, but the spiders that make no web gave not the slightest heed to the sound. It is suggested that this difference may be partly explained by the difference in the feeding habits of the two groups.

*Maternal Emotions.* Notwithstanding many efforts the authors never found one of the Lycosidæ that was constant in her affection for as long as forty-eight hours. A female of *Clubiona pallens*, however, remembered her eggs for this length of time, and when they were returned to her, she spun a web over them in the corner of the box in which they were placed. *Theridium globosum* had the best memory for her cocoon; after fifty-one hours' absence she at once went to the eggs, and touched them with her legs. Several species of Attidæ and Thomisidæ did not remember their cocoons for twenty-four hours, although these spiders, which do not carry the egg-sac about with them, remain near it for from fifteen to twenty days.

*Sense of Sight.* It is well known that spiders are supposed not to see their own cocoons at a very short distance; the authors explain this by describing how the cocoon is made without its maker ever even seeing it, and they come to the conclusion that the use of the sense of touch is necessary for the spider to be able to perceive the cocoon.

*Colour Sense.* There is a marked preference for red, and there can be no doubt that some spiders have a distinct colour sense.

*Feigning Death.* The authors consider the gist of the matter to be this; certain Epeiridæ, when alarmed, drop from the web and remain quiet for a longer or shorter time, their concealment being greatly assisted by the protective colouring which is present to some extent in nearly all of them. This amounts to nothing more than that when another spider runs to a place of safety, an Epeirid drops a greater or less distance to a place of safety. Both then remain quiet, unless disturbed, in which case the first spider trusts to its powers of running, while the Epeirid often (but not invariably) finds its best chance of safety in keeping quiet unless it is actually abused; the habit of keeping quiet also insures the spider's safe return to its web when the danger is over. There is no need to call in "kataplexy" to explain the origin or development of a habit which can be so easily explained by natural selection alone. The habit is found in its greatest development among the comparatively sluggish Epeiridæ, whereas it is badly developed or lacking in the running and jumping spiders which are able to move with astonishing rapidity.

*Mistakes of Spiders.* Spiders were found to be much less clever than supposed, in regard to the recognition of their cocoons, little pith-balls leading them quite astray. If allowed a choice a Lycosid will select the

\* Journ. of Morphology, i, (1887) pp. 383-419.

cocoon rather than the pith-ball, but in the absence of the former will content herself either with a pith-ball or a web-covered shot. The carrying of the latter indicates a poorly developed muscular sense.

**Brain of Phalangida.\***—M. G. Saint-Rémy has examined the brains of *Phalangium opilio*, and *P. parietinum*. He finds that the brain may be divided into two ganglionic regions; the optic ganglion which gives rise to a pair of optic nerves, and a rostro-mandibular ganglion from which arise an unpaired nerve which passes to the rostrum, and a pair of mandibular nerves which go to the chelicerae.

Though the brain of the Phalangida is much simpler than that of Insects or Crustacea it has some points in common with them which are of some importance. At the origin of each optic nerve there is a lobe, of comparatively complicated structure, which is altogether comparable to what is known as the optic ganglion in Insects; the same lobe, in a simpler condition, has been observed in the Scorpion and in Spiders. In the optic ganglion of the Arachnida there are, further, ganglionic nuclei which seem to be found in sensorial ganglia only, and have been observed in Insects, Crustacea, and Myriopoda.

#### 8. Prototracheata.

**Monograph of the Genus Peripatus.†**—Mr. A. Sedgwick has prepared a monograph of the genus *Peripatus*, which is based on the examination of a considerable number of specimens. He has been able to establish a definite series of characters which distinguish quite sharply all the species found in one area of distribution from those found in others. The number of walking-legs varies considerably within the same species, and a large number of individuals are required to determine the limits of the variation. The other specific characters are very inconspicuous, and relate simply to the texture and tint of the skin.

A general account is given of the genus, within which, as is pointed out, there is no gradation; the number of species is small, and the characteristics of the genus are equally sharply marked in all. The long continuance of this ancient form may be explained by its peculiar habits of life—habitual avoiding of the light of day, and seeking the obscurity and protection afforded by spaces beneath stones and under the bark of trees. It is an animal of striking beauty: “the exquisite sensitiveness and constantly changing form of the antennæ, the well-rounded plump body, the eyes set like small diamonds on the side of the head, the delicate feet, and, above all, the rich colouring and velvety texture of the skin, all combine to give these animals an aspect of quite exceptional beauty.”

In South Africa there are four species—*P. capensis*, *P. balfourii*, and *P. brevis* from Table Mountain, and *P. moseleyi* from near Williamstown. The Australasian species are *P. novæ Zealandiæ* from New Zealand, and *P. leuckarti* from Queensland, Australia. From the Neotropical Region *P. edwardsii* from Caracas, *P. im thurni* of Sclater (or *P. demeraranus*, as Mr. Sedgwick proposes to call it) from Demerara, *P. trinidadensis* (*P. edwardsii* Kennel) and *P. torquatus*, described by v. Kennel from Trinidad, and *P. juliformis* from St. Vincent; the Chilian species may be called *P. chilensis*; Schmarda has given a short description of *P. quitensis*

\* Comptes Rendus, cvi. (1888) pp. 1429–31.

† Quart. Journ. Micr. Sci., xxviii. (1888) pp. 431–93 (7 pls.).

from Quito, Ecuador. Some specimens in the British and Copenhagen Museums cannot be specifically determined. The author has some doubts as to the locality of the species described by Horst from Sumatra (*P. sumatranus*), as it has a number of the characters of Neotropical species.

**Anatomy of *Peripatus capensis* and *P. novæ Zealandiæ*.\***—Miss L. Sheldon has some notes on the points in which these two species differ from *P. edwardsii*. *P. capensis* always seems to have crural glands in all but the first pair of legs; in *P. novæ Zealandiæ* they seem to be quite wanting, while in *P. edwardsii* they are found on some of the legs of the male. In *P. novæ Zealandiæ* the external aperture of the generative apparatus is placed on the ventral surface of the body in front of the last pair of legs, and there are no segmental organs in this pair; in *P. capensis* the generative aperture is placed at the posterior end of the body, and the last pair of legs has segmental organs. In *P. novæ Zealandiæ* the accessory glandular tubes lie more laterally in the body than in *P. capensis*, and they also differ in opening quite independently of the vas deferens. This duct is much shorter in *P. capensis* than in *P. novæ Zealandiæ*; and this difference appears to be due to the very great difference between the spermatophores of the two species; in *P. novæ Zealandiæ* the duct very closely resembles that of *P. edwardsii*. The ovarian funnel described in *P. edwardsii* is not found in the New Zealand species.

#### e. Crustacea.

**Intercoxal Lobe of certain Crayfishes.†**—Mr. W. J. Mackay has examined certain appendages connected with the branchiæ of *Astacopsis Franklinii*, which have been figured but not described by Prof. Huxley. These bodies, which may be called the intercoxal lobes, have the upper portion of the anterior face attached to the arthro-dial membrane, while the lower surface of the anterior face is attached to the base of the coxopodite, which is smooth and convex. The lower portion of the surface first exposed when the base of the podobranch is removed, is covered with setæ which project prominently from its surface; the anterior face is concave, and is so well able to fit on the convex base of the coxopodite. The whole arrangement is such as to lead us to suppose that the intercoxal lobe acts as a valve between the thoracic limbs and the branchio-stegite, and prevents the too ready entrance of foreign bodies. In *Astacus fluviatilis* the only representative of this lobe is a small hard ridge on the arthro-dial membrane of the fourth pair of legs; in *Homarus vulgaris* the lobes occur in the limbs of the 9th to the 13th segments. No representative of this structure was found in any anomurous or brachyurous crustacean which was examined.

**Development of *Alpheus*.‡**—Mr. F. H. Herrick has been able to make a complete study of the development of *Alpheus*. He has been convinced that the germinal layers in the early stages of development have not the significance which is usually assigned to them. "The mass of cells which results from gastrulation, some of which are poured into the yolk, is an unspecialized indifferent layer, and cannot be regarded

\* Quart. Journ. Micr. Sci., xxviii. (1888) pp. 495-9.

† Proc. Linn. Soc. N. S. Wales, ii. (1888) pp. 967-9.

‡ Johns-Hopkins Univ. Circ., vii. (1888) pp. 36-7.

as mesoderm and endoderm in the sense in which these terms are used." The ectoderm is, by its position and function, more clearly defined from the first.

The enveloping chorion functions as an egg-sac. When the fertilized nucleus divides, its products pass towards the surface until a syncytium of eight nuclei is formed; the yolk segments over the whole surface simultaneously into the same number of partial pyramids; each of these latter has a large nucleus at its base, while its apex fuses with the common yolk-mass in the interior of the egg. After a time, by retardation in one half, the egg loses its radial symmetry, and becomes two-sided. When the primitive blastoderm is formed, a general migration of nuclei takes place from the surface to the yolk within; this is followed by a partial secondary segmentation of the food-yolk into balls.

The gastrula is modified, a slight invagination occurring where the superficial cells are thickest; the included cells multiply rapidly, and form a mass of similar elements, some of which pass into the yolk. The protoplasm surrounding the nuclei of these cells is prolonged into a reticulum which incloses myriads of small yolk-fragments, and probably digests them intercellularly.

At the beginning of the egg-nauplius period, when numerous yolk-cells have passed forward and joined the inner surface of the embryonic ectoderm, certain new bodies begin to appear in great numbers. These are the secondary mesoderm cells, and they arise by a process of endogenous growth from the embryonic cells or nuclei, and chiefly from the wandering cells. Some of them appear to become ordinary mesoderm cells, while others seem to be converted directly into blood-corpuseles.

The plasticity of the embryonic cells and layers and the comparative slowness with which they are clearly differentiated are very striking; the cell-mass developed round the blastopore cannot be artificially divided into layers. The endoderm, which does not appear definitely till comparatively late, is developed from yolk-cells which assume a peripheral position.

*Moina bathycolor* and the greatest depths at which Cladocera are found.\*—Dr. O. Nordqvist refers to Herr J. Richard's paper on *Moina bathycolor* Vernet, and points out that last year he suggested that this form was probably the same as *Ilyocryptus acutifrons* Sars. *Ilyocryptus*, *Alona*, and *Eurycereus* are the Cladocera which are found at greatest depths—as far as 200 metres down.

## Vermes.

### a. Annelida.

Embryology of *Vermilia cæspitosa* and *Eupomatus elegans*.†—Mr. W. A. Haswell has some notes on the development of these two Annelids, in both of which artificial impregnation was readily effected. In *Vermilia* segmentation is equal and regular, as in *Serpula* and *Pomatoceros*. The blastopore, which is at first nearly terminal, becomes shifted to that side of the larva which will be the ventral; at the same time it becomes elongated and slit-like, the anterior end of the slit widening to form the mouth, while the anus is formed near the posterior end at a somewhat later stage. When the process of invagination

\* Zool. Anzeig., xi. (1888) pp. 264-5.

† Proc. Linn. Soc. N. S. Wales, i. (1888) pp. 1032-4.

commences the larva is uniformly covered with cilia; the cephalic end soon loses them, but becomes surrounded just in front of the mouth by a strong præoral ciliated band. The epiblast of the cephalic end becomes thinner than the rest, except in the centre, where a group of thicker cells remains to give rise to the cerebral ganglion. From the broader anterior end of the pyriform embryo one or sometimes two long and slender motionless flagella occasionally grow out; the alimentary canal becomes densely ciliated internally, and a few irregularly placed cells are to be found between the epi- and hypoblast, which are probably the foundations of the middle layer.

In the course of the third day the præoral circlet of cilia becomes elevated on a distinct, slightly oblique ridge, and a reniform eye-spot becomes developed at a little distance from the ganglion, with which it is connected by a fibrous strand. A thin-walled vesicle which appears at the hinder extremity of the body soon attains a considerable size; it is apparently formed by involution of the epiblast, and remains connected with the exterior by a pore at the side of the anus.

The larva of *Eupomatus* is much smaller than that of *Vermilia*.

**Reproductive Organs of Phreoryctes.\***—Mr. F. E. Beddard describes the reproductive organs of a new species of *Phreoryctes* from New Zealand. There are two pairs of testes, which are large bodies, of, apparently, an irregularly conical form; an identical arrangement is seen in *Oenerodrilus*. There are two pairs of vasa deferentia, the funnels of which are simple flattened discs, with an epithelium composed of rather small, columnar, ciliated cells, so that they are not readily found. All four vasa open independently, and there are no atria. So far as is known this is a unique arrangement among the Oligochæta. The simplicity of the efferent ducts in *Phreoryctes* suggests that they are in a primitive condition. There are two pairs of ovaries, and as there are two pairs of oviducts we may suppose that the peculiar possession of the two pairs of ovaries is not an abnormal arrangement in this species. *Phreoryctes* differs from all Oligochæta except *Lumbriculus* in the fact that there are two pairs of oviducts opening on a line with the ventral pair of setæ between segments 12 and 13, and segments 13 and 14. The close agreement between the ducts as well as the glands of the male and female reproductive systems in *Phreoryctes* is more apparent than in any other Oligochæte, and is probably to be regarded as an indication of the archaic condition of the reproductive system of this Annelid.

**Kleinenberg on Development of Lopadorhynchus.†**—Mr. G. C. Bourne calls attention to Prof. Kleinenberg's paper on the development of *Lopadorhynchus*.‡ One important point on which Kleinenberg insisted was that there is no such thing as a mesoblast as a specially developed germ-layer. The mesoblast, so called, is in fact nothing more than the aggregate of the primary, secondary, and tertiary tissues, the precise origin of which is often obscured by the tendency to precocious development. The study of *Lopadorhynchus* shows that the internal organs of the adult Annelid are developed by successive differentiation of derivatives of the two primary layers, ectoderm and endoderm. This Annelid has no mesoblast in the sense of a germ-layer composed of

\* Ann. and Mag. Nat. Hist., i. (1888) pp. 389-95 (1 pl.).

† Quart. Journ. Micr. Sci., xxviii. (1888) pp. 531-46.

‡ See this Journal, 1837, pp. 87-8.

undifferentiated cells. The larva has its own nervous system and its own musculature, no parts of either of which pass over to the adult, but are replaced by a new nervous system and musculature, and are afterwards aborted. The central nervous system of the adult is formed from a number of separate centres or foundations, the situation of which is in part determined by the pre-existing nerve-centres of the larva, although the latter have no direct share in their formation, but act only as foci, in connection with which fresh groups of nervous elements are differentiated. The muscle-plates do not split into two layers, comparable to the somatopleure and splanchnopleure, and the cœlom is formed simply as an extension of the space existing between ectoderm and endoderm, the peritoneal walls of which are formed by cells derived from the muscle-plates. All the tissues usually classed as mesoblastic are derived from the ectoderm, and the endoderm appears to form nothing more than the lining of the gut.

Kleinenberg does not believe that a new organ is formed by the gradual growth or change of a pre-existing organ. "In animals of simple organization, tissues and organs are formed to which special functions are appropriate. Their functional activity is, as it were, a disturbing element in the organism; it induces changes in neighbouring tissues, and gives the signal for new specializations in them. The functional activities of the newly specialized tissues must always bear some relation to the function of the organ which determined their origin, and must either support or modify their action. The newly formed tissues again affect the organism; their importance increases, and they may in time give rise to fresh tissues. Finally, they may become so important that they outweigh in functional importance the organ to which their origin was due; they then take its place, and the latter dwindles till finally it may disappear altogether. This process, which is of the greatest importance, is called by Kleinenberg the development of organs by substitution. . . . In no case of substitution are the intermediate steps represented by an indifferent germ-layer, but always by a functional and specifically differentiated organ." A striking instance of this is the development of the axial skeleton of the Chordata; another is the successive development of pro-, meso-, and metanephros. "Rudimentary" organs are thus seen to be intermediary.

It is an open question whether Kleinenberg's views will stand the test of further proof, but it cannot be doubted that investigations undertaken from his point of view must be fertile in results. It is better to trace back organs through the intermediary organs which gave them origin, and to attempt to establish homologies between the latter and the permanent organs of lower forms than to attempt to refer an organ merely to one of the three primary germ-layers.

**Experiments on Earthworms.**†—Herr W. Kükenthal describes some interesting observations and experiments which he made on earthworms. After noting the nature of the secretion which comes from the body, which includes entire glandular cells from the hypodermis, he describes how he fed the animals with carmine and indigo in order to test whether the above glandular cells were not in certain conditions excretory. The result proved that the granules of carmine were taken up by the cells of the gut which become amœboid. Lang observed a similar amœboid

\* Biol. Centralbl., viii. (1888) pp. 80-6.

change in regard to Polycladidæ. The carmine grains were further traced in the body-cavity to lymph-cells where they were angular, and to loose chloragon-cells where the grains seemed to be in drops. He believes from his observations that the carmine entered the chloragon-cells *via* the blood, while it entered the lymph-cells directly from the cells of the gut. No carmine particles were ever found in the nephridia; but they were found in the cells of the hypodermis, whither they were probably carried by the lymph elements. The author thus shows that waste matter may pass from gut to hypodermis. Further observations are promised in the author's forthcoming monograph of the Opheliaceæ.

**Russian Lumbricidæ.\***—Herr N. Kulagin has investigated the anatomy and systematic characters of the Lumbricidæ which are found in Russia. The cuticle is shown by chemical analysis not to be chitin, but a special body, which, so to say, is preparatory to the chitin of Arthropods. This cuticle is easily soluble in quite weak solutions of hydrochloric acid, the presence of which can be easily demonstrated in the humus in which earthworms live; as a protection against this acid there is excreted from the ectodermal glands a protective alkaline fluid. The cocoon of *L. rubellus* resists acids more strongly, and is not dissolved in pepsin. The number of folds in the calcareous glands diminish in winter and increase in summer; the so-called investing cells disappear in winter and reappear in summer.

The hypodermis of the labium contains, in addition to cells already described, knobbed cells, the widened ends of which are connected with nerves; at their free end they are provided with setæ which traverse the cuticle; these may best be regarded as sensory cells. Besides these there are on the second and third rings cylindrical cells connected with nerves; these cells are somewhat narrowed at their anterior end, while at the posterior they have one or two processes which are connected with nerves. In the lower layer of the hypodermis there may be found all the intermediate stages between the cells that form the upper layer of the hypodermis and those which lie in the cœlom and between the muscular cells.

Two pigments were discovered in *L. rubellus*, one is green and is dissolved by water, the other is red and can be extracted by ether; the former appears to be converted into the latter by the action of acid. In young examples of *Allolobophora mucosa* it was observed that the muscles in the region of the pharynx occupy very much the same position as those which protrude the proboscis in *Aeolosoma*; in the adult this position is masked by the enlargement of the tissue of the connective substance and of the muscles of the walls of the pharynx.

The author's observations on the calcareous gland of *Lumbricus rubellus*, *Allolobophora mucosa*, and *A. fetida* do not agree with those of Claparède. He has found calcareous glands in a new species of *Tubifex*, or, in other words, in *Oligochæta limicola* as well as *O. terricola*. The typhlosole is found to vary in form in different genera, in different parts of the body, and at different times of the year.

The fluid secreted from the cavity of the mouth and pharynx is alkaline in reaction and converts starch into sugar, and fibrin into peptone; the calcareous glands are said to convert starch into sugar;

\* Zool. Anzeig., xi. (1888) pp. 231-5.

the gastric secretion of *L. rubellus* and *A. mucosa* appears to act better in the presence of weak acids than in that of alkalis. The cells of the typhlosolo not only serve in absorption, but have a digestive function similar to that of the pancreas in Vertebrates.

*L. rubellus* and *A. fetida* are found as far north as the mouth of the Lena. In Siberia there is *A. tenuis*, which has, as yet, only been found in North America and Scandinavia. *L. multispinus* and *L. brevispinus* are synonyms of *A. mucosa*. In the Caucasus, the new species *L. caucasicus*, *Dendrobæna Bogdanowii*, and *D. Nassonowii* have been found, in addition to *A. arborea*, *A. profuga*, *A. longa*, and *A. subrubicunda*, which have also been found in the Crimea and in South Russia. In Central Russia, *A. mucosa*, *A. carnea*, *A. pellucida*, *A. fetida*, *D. Beckii*, *L. rubellus*, and *L. agricola* have been found.

**New Annelid, *Sutroa rostrata*.**\*—Mr. G. Eisen describes, under the name of *Sutroa rostrata*, a new Lumbriculino found near San Francisco. The seminal receptacles consist of several pairs of lobes, which all open in the so-called albuminous gland in the eighth segment. A solitary albuminous gland is found in the eighth segment. Preseptal and interseptal secondary dorsal vessels are branching and feathered. Postseptal vessels are gastric, not feathered, nor branching; spines simple, not forked; cephalic lobe filiform. The new genus is closely allied to the two known genera of the sub-family Lumbriculina—*Lumbriculus* and *Rhynchelmis*. The "albuminous gland," however, differs somewhat in structure; for, instead of being distinctly glandular, it is covered by smooth epithelium, under which are found numerous long and narrow cells. All the six seminal receptacles, moreover, open into the gland instead of having separate pores. The segmental organs are found in all the segments behind the twelfth, and are very similar to those of *Rhynchelmis*. The dorsal vessel differs from that of the other two genera in not being forked.

**Two new Aquatic Worms from North America.**†—Dr. A. C. Stokes points out that very little is yet known as to the oligochaetous worms of North America. *Acolosoma distichum* sp. n. is very abundant in stale, or even partially decayed collections of aquatic plants; it is about 2/5 in. long, but none have yet been seen in the sexually mature stage. The body is colourless, depressed, changeable in form, and attractively variegated by the large, irregular, red spots which are distinctive of the genus. There is a large subcircular lip, the lower surface of which is clothed by fine vibratile cilia; laterally and posteriorly to the mouth there is a thick, muscular, U-shaped lip. The nephridial tubes begin with a slightly expanded orifice which is clothed with long, fine cilia; there is no undulating membrane. The labial cilia are the chief swimming organs. *Pristina flavifrons* sp. n. has been found abundantly on the under surface of *Lemna polyrrhiza*, and among the leaflets of *Myriophyllum*; the setæ on the body are short, widely separated, and there is no invariable rule as to the number of stylets in each fascicle. No sexually mature forms have been observed, reproduction being effected by fission.

\* Mem. California Acad. Sci., ii. (1888) pp. 1-8 (2 pls.).

† The Microscope, viii. (1888) pp. 33-41 (1 pl.).

### β. Nematelminthes.

**Fertilization of *Ascaris*.**\*—Dr. N. Kultschitzky contributes yet another account of the phenomena of fertilization in *Ascaris megalocephala*.

(1) *Formation of polar bodies.* Boveri's account is confirmed; but, like Zacharias, the author maintains the presence of two achromatic spindle figures lying beside one another. (2) *The modifications of the spermatozoon* are described in a few words. Reason was seen to believe that not the whole chromatin goes to the formation of the male pronucleus. (3) *Formation and structure of pronuclei.* Both appear to be constructed on the same plan. The author notes as new that each has a characteristic nucleolus, sometimes two, rarely three, but the same number always in both. The results being similar, while the components of the two pronuclei are originally very different, the process of formation is regarded as something *sui generis*.

(4) *The number of pronuclei* is usually two; very rarely there is only one, somewhat more frequently three. The single pronucleus is probably that of an unfertilized ovum; the presence of three is perhaps due to the entrance of a bi-nucleate spermatozoon. (5) *First processes in development.* After the formation of two pronuclei, there is no further change while the eggs remain in the uterus of the living *Ascaris*. Herr Kultschitzky is convinced that without exception the karyokinesis of each pronucleus is independent. The attractive spheres of van Beneden belong to the protoplasm, and represent the first hints of incipient protoplasmic division. The changes seen after the formation of the pronuclei pertain strictly to the segmentation.

(6) *Minutiae of fertilization.* The essence of fertilization consists in the process by which the sperm-nucleus—an element foreign to the ovum—is modified into an essentially inseparable component, a nucleus of the same. The act is ended with the establishment of the male pronucleus, what follows belongs to development. A fusion of the pronuclei, when such exists (the author doubts it), does not pertain to the strict process of fertilization.

**Intestinal Epithelium of *Ascaris*.**†—Prof. S. M. Lukjanow has investigated the epithelium of the intestine in *Ascaris mystax*. He recommends strongly double imbedding with a combination of collodium and paraffin, and double staining with hæmatoxylin and aurantia.

Between the cells and the homogeneous membrane below them is a clear space traversed by very fine threads parallel to the long axis of the cells. Externally the cells exhibit filiform processes like cilia. The cells contain granules, in part at least, consisting of fat. The possible physiology is briefly noticed; certain not very noteworthy variations in the size, position, membrane and structure of the nuclei are noticed in detail; and the plasmosomata to which the author has recently directed much attention are fully discussed.

**Studies on *Gordiidae*.**‡—Prof. F. Vejdovsky has lately had the opportunity of examining a large number of specimens of *Gordius tolosanus*. He has some evidence as to variability in the arrangement of the cuticular areolæ, which he discusses at some length. He does not

\* SB. K. Preuss. Akad. Wiss. Berlin, 1888, pp. 17-21.

† Arch. f. Mikr. Anat., xxxi. (1888) pp. 293-302.

‡ Zeitschr. f. Wiss. Zool., xlvi. (1888) pp. 188-216 (1 pl.).

agree with Villot's conceptions of the limits of species of the genus *Gordius*. The coelom of all the females examined was found to be very well developed, and in no case was the anterior or median region filled by the so-called cellular tissue; but this was present in the hinder part of the body-cavity. In no individual were the elements of the peritoneal epithelium found dividing, from which it may be concluded that there is no formation of cell-tissue at the time when the ova are being produced.

A peculiarity was noticed in the peritoneal cells; beside the nucleus there is a small body which is only faintly coloured by picrocarmine; it has an irregular contour, and is generally lobate; its contents are almost homogeneous, and its size is 0.003–0.005 mm. It is impossible to say definitely what this body is, but it appears to be a thickened portion of the cell-substance.

The mesenteries are mere continuations of the modified peritoneal epithelium.

The author makes some additions to his earlier account of the nervous system. He has already shown that the ganglion-cells only occupy the lower part of the ventral cord, and that in *Gordius Presslii* there are transverse commissures which, in some sections, are to be seen in the dotted substance. In *G. tolosanus* he finds that some sections show on either side a ganglionic cell which gives off a process to the dotted substance; the two processes fuse and form the transverse commissure. As this is again repeated after a number of sections in which it is not to be seen, we may suppose that the lateral ganglionic cells and the transverse commissures are repeated in a definite order; this is a fact of some significance in the morphology of the Gordiidæ, especially when we consider that the ovaries are arranged symmetrically in the body-cavity.

The author at one time believed that he could recognize the peripheral nervous system in the so-called neural lamella, but with more satisfactory material he has been able to see that in some transverse sections there is no lamella. It must, therefore, be concluded that the peripheral nervous system is not represented by a continuous median lamella, but by separate nerve-stalks closely succeeding one another. Separate ganglionic cells send off their processes towards the hypodermis inclosed in a homogeneous sheath-like membrane, which appears to be a continuation of the capsular investment of the ganglionic cells.

The author has altered his view as to the nature of the so-called dotted substance, which he regarded as fibrillar or fibrous substance, as he has now convinced himself that there is a real network. He proposes to speak of the substance as "neural reticulum," or simply "nerve-network." He believes that the neural reticula of Mollusca, Arthropods, and Worms are completely homologous structures. To understand this substance properly, it must be examined during the course of its development; the author has done this in *Oligochæta*, with the following results:—In each half of the ventral cord, four upper cell-rows of the primitive ganglionic rudiments take part in forming the nervous tissue. As the cells increase in size their membranes become absorbed, and in each half of the ganglion we get a syncytium with four nuclei. The latter lose their membranes and swell up considerably, so that the regularly disposed nuclei touch. The swelling of the nuclear substance continues, the nucleoli become absorbed, and the nuclear reticulum becomes very distinct. The cytoplasm which surrounds them forms at

first a broad hyaline area, in which the filaments of the network are only indistinct. As the nuclear network grows, the surrounding protoplasm becomes more and more indistinct, while the fibres of the successive nuclei fuse with one another. Finally, the two upper rows of nuclei unite, and we get the neural reticulum. This, in sections of each half of the ganglion, has the form of three plexiform areas, two inferior and one superior; the lower are separated from the upper by the cytoplasm, in which the processes of the ganglia form the transverse commissures.

The youngest ovaries of Gordiidæ are characterized by the absence of lateral lobes and ovarian cavities; in the older ovaries each lobe consists of similar cells, and has a racemose form; their cavities communicate directly with the lumen of the receptaculum ovarum, the walls of the latter being continuations of the epithelium of the ovary. The development of ova does not occur in all the lobes, but in a few only; it is very simple, some epithelial cells of the ovarian lobes growing considerably, their protoplasm being converted into yolk-granules, and the nuclei increasing a little in size; but the change appears to be effected very rapidly. It is very probable that several epithelial cells are simultaneously converted into ova, the consequence of which is that the eggs take on a shield-shaped or polyhedral form. The mature ova pass directly from the ovarian tubules into the receptaculum ovarum; this last is provisionally regarded as a modified excretory organ, but this supposition must be tested by embryological investigations. In well-preserved material it is possible to see that the receptaculum has proper walls. The atrium, the oviduct, and the seminal pouch have probably all arisen from an evagination of the hind-gut. The cloaca of *G. tolosanus* is much more evident than that of *G. Presslii*.

In appendices the author deals with some recent statements of M. Villot, and with Herr Nansen's account of the nervous system of *Myzostoma*.

**Anguillulidæ of the Onion.\***—M. J. Chatin, who has given an account of the disease caused by *Tylenchus putrefaciens* in the edible onion (*Allium Cepa*), has continued his observations on the nematode parasites of this vegetable. He has been able to recognize three species, *Pelodera strongyloides*, *Leptodera terricola*, and *T. putrefaciens*. The last of these appears to be the cause of the disorganization and destruction of the bulb, and the premature destruction of the appended organs. The first two are only met with in the superficial parts of the plant, or only follow *T. putrefaciens* into the deeper parts; they are simple "saprophytes."

***Tylenchus devastatrix*.†**—In a third communication on the natural history of *Tylenchus devastatrix*, Herr Ritzema Bos discusses the diseases which this Nematode causes on plants. He discusses first the disease of rye, marked especially by the abnormal swelling of the stem base. The relevant literature, the nomenclature, and the symptoms are noted, and the disease is illustrated in two cuts. He emphasizes the fact that it is by the soil that the worms are perpetuated, and notes how the activity of the parasites themselves, the action of wind and water, and even human agencies effect propagation. In the second place he discusses

\* Comptes Rendus, cvi. (1888) pp. 1431-3.

† Biol. Centralbl., viii. (1888) pp. 129-38.

the tulip-root disease of oats, in which he found in specimens supplied by Miss Ormerod the constant presence of *Tylenchus devastatrix*.

In his final report\* the author treats of other diseases of onion, hyacinth, clover, fuller's teasel (*Dipsacus*) &c., and gives in all nine figures of affected plants. The details have rather an agricultural than a general biological interest, though the latter is by no means overlooked.

#### γ. Platyhelminthes.

**Embryogeny of Fresh-water Dendrocoela.**†—Dr. P. Hallez has observed that in *Planaria polychroa* the cocoon is formed in the uterus and not in the genital cloaca, as is the case in *Dendrocoelum lacteum*; he believes that the bursa copulatrix will be shown to be a propelling organ, the function of which is to introduce the ova and fertilizing elements into the uterus. An account is given of the yolk-cells, their structure, and the formation from them of a synectial mass which surrounds the eggs. The period of maturation of the egg is characterized by the formation of a certain number of clear vesicles (three in the case of *D. lacteum*) which arise at one of the poles of the egg, in the neighbourhood of the nucleus. These bodies are, finally, eliminated; they are certainly homologues of the formations to which Sabatier has especially called attention; the author suggests that they have no more significance than the liquid which is expelled by the contractile vesicles of the Protozoa. No polar globule is formed. The fecundated egg is surrounded by a score of radial vitelline cells, which are nearly conical in form, and are attached to the egg by their base. The blastomeres of the 2-stage are equal, as are also those of the 4-stage. After the 8-stage the surrounding synectium begins to be formed. About the stage in which there are 20 cells a new series of vitelline cells becomes disposed radially around the embryo, and this likewise becomes synectial. From this mode of distribution of the nutrient elements M. Hallez applies the term ectolecithal to the eggs of fresh-water Dendrocoela.

The first organ to be differentiated is the primitive ectoderm; this is formed by the most external embryonic cells, which approach the periphery of the synectium, and there become flattened. During the whole course of development fresh embryonic cells are continually becoming flattened on the surface of the embryo, and being converted into ectodermic cells; in this way the ectodermal membrane of the embryo insensibly passes into the epidermic investment of the adult. When the primitive ectoderm has been formed, three groups of blastomeres may be distinguished in the embryo; those of the rudiment of the pharynx consist of about twenty cells; immediately behind these there are four primitive endodermic cells; and, lastly, there are about fifty migratory cells. Till the provisional pharynx begins to function, the archenteron is merely lined by the four initial cells of the endoderm; but when the vitelline cells pass into the intestinal cavity, the endoderm increases considerably in size, and some of the migratory cells become connected with the four primitive endodermic. The blastomeres, when undergoing histological differentiation, incorporate a certain quantity of the nutrient synectium which surrounds them. After the embryonic

\* Biol. Centralbl., viii. (1888) pp. 164-78.

† Arch. Zool. Expér. et Gén., v. (1888) pp. xxxix.-xliii.

pharynx begins to function, the migratory cells which are scattered in the syncytial mass continue to divide and increase considerably in number.

The straight or rhabdocœlic intestine becomes dendrocœlic by the development of septa, which arise from the periphery and make their way towards the interior in a manner which recalls the septa of Anthozoa. The permanent endoderm is formed of the migratory cells which lie on the internal surface of the walls of the body, and not, as Metschnikoff thinks, of yolk-cells swallowed by the embryo. The rhabdites, the brain, and the organs of sense are developed at the expense of the cells of the connective reticulum.

M. Hallez recognizes, in fresh-water Planarians, only two layers—the ecto- and endoderm. The migratory cells which give rise to various organs are regarded as homologous with the “pseudomesoderm” of Cœlenterata, the nutrient syncytial mass corresponding to their gelatinous mass. With regard to the affinities of the Turbellaria, the author admits that the solid mesoderm of the Pseudocoelia of the Hertwigs is homologous with the mesoderm of the Entero-cœlia; that the pseudomesoderm of Cœlenterates and the cutis-cells of Echinoderms are homologous ectodermic differentiations, and that the gastric diverticula of the Ctenophora are homologous with those of Echinoderms. Starting with these bases he divides multicellular animals into four groups:—(1) Mesozoa, characterized by ectoderm and endoderm only; (2) Porifera or Cœlenterata, characterized by ectoderm, pseudomesoderm, and endoderm; (3) Ctenophora and Echinodermata, with the three germinal layers and pseudomesoderm; and (4) the rest of the Metazoa, with three layers but no pseudomesoderm. Having shown that most of the Polyclades have a true mesoderm, while the Tricladæ and *Stylochus* have not, he concludes that the Dendrocœla which possess a primitive mesoderm, ought to be associated with the fourth group, while the Dendrocœla which have only a pseudomesoderm, ought to be associated with the second, and more particularly with the true Cœlenterata.

From this point of view the connective reticulum of the Polyclades is seen not to correspond morphologically to that of the Tricladæ; this is supported by a number of anatomical and embryological facts. M. Hallez is not convinced by the arguments which have been adduced in favour of the descent of the Dendrocœla from the Ctenophora, but thinks that the ancestors of the former must rather be sought for among the Anthozoa.

The Rhabdocœla, as much as the Dendrocœla, may be divided into two groups, according as they do or do not possess a pseudomesoderm. The Microstomea will probably be found to be allied to *Hydra* or *Protohydra*.

**Lateral Organs.\***—Prof. W. Salensky discusses the homology of the lateral organs of Nemertean in connection with an observation made by the brothers Sarasin on peculiar “cerebral tubes” in the embryos of *Helix waltonii*. These tubes arise on each side of the cerebral mass as two invaginations of the sensory plates, and were compared by the discoverers with the smelling organs of some Annelids (e.g. *Lopadorhynchus*). With this Salensky entirely agrees. He goes further, however,

\* Biol. Centralbl., viii. (1888) pp. 79-80.

and regards both the structures above mentioned as homologous with the lateral organs of Nemerteans. The similarity in development is undoubtedly very striking, and according to Salensky warrants us in associating the three eventually very different organs in a morphological series.

*Bilharzia*.\*—Herr G. Fritsch has reinvestigated the anatomy of *Bilharzia hæmatobia* Cobbold. In the introductory chapters the occurrence and distribution of this important parasite, its probably almost unexceptional origin from impure water, its various names, and the curious copulatory conditions are discussed.

The author then gives a detailed account of the structure of the female, of which we have hitherto been to a great extent in ignorance. The skin is not smooth, but covered with minute, scattered, readily broken spines. They are directed forwards, and perhaps hinder the animal from slipping out of the *canalis gynæcophorus*. The mouth, pharynx, and divided limbs of the alimentary canal are then noticed. The vagina leads to the expanded uterus, and a narrowed portion of the latter ought to be called the oviduct. He identifies as the shell-gland what Bilharz called the "capsule," and treats of the unpaired ovary, the large vitelline organs, the hitherto undescribed excretory apparatus, and the distinct caudal excretory pore. The next chapter describes the position of the above organs in cross sections. The author then discusses the histological details:—the clear refractive cuticle without distinct subcuticular layer, the inconspicuousness of distinct skin-glands, the sparse longitudinal muscular fibres, and the absence of any closed circular sheath, the connective tissue of the parenchyma, and the like. The histology of the reproductive organs is described in detail. No Laurer-Stieda canal was to be found. As was to be expected, very little of the nervous system could be made out.

The structure of the male is very simple. The formation of the gynæcophoric canal, the suckers stronger than those of the female, the slight development of the alimentary canal, the union of the two limbs as in the female behind the generative gland, the position of the testis very near the ventral sucker, the opening of the vas deferens in the depth of the first part of the *canalis gynæcophorus*, the absence of any copulating organs, are described at length. Finally, the histology is briefly reviewed. The strong cuticle with its fine spines, the longitudinal muscles, the practical absence of glands, the muscular pharynx, the muscular seminal vesicle without distinct epithelium, but with peculiar cuticular insheathing, the central nervous system more distinct than in the female, are shortly described.

#### 5. *Incertæ Sedis*.

*Balanoglossus Mereschkovskii*.†—Herr W. Schimkewitsch gives an account of this northern species of *Balanoglossus*. The body may be divided into three parts: cephalic lobes, a single body-segment, and a hinder unsegmented portion; it may be compared with a larval Ascidian, save that the latter has no cephalic lobes. The unpaired head-cœlum opens to the exterior by means of a left excretory canal only; the latter exhibits the same relation to the peritoneum of the cœlum as do the

\* Arch. f. Mikr. Anat., xxxi. (1888) pp. 192-223 (2 pls.).

† Zool. Anzeig., xi. (1888) pp. 280-3.

ectodermal parts of the segmental organs to their mesodermal rudiment. As, however, there are two canals in *B. Kuppferi*, we may homologize their duct with the cephalic segmental organs (but not with head-kidneys).

The folds of the inner peritoneal layer have not, as Bateson thought, anything to do with the so-called proboscis gland, but rather have the same kind of relation to the vascular system as have the pericardial glands of Annelids; their function is that of excretory organs. The proboscis gland of Bateson (heart of Spengel), has a proper muscular wall, while its epithelium is like that of the endothelium of some parts of the peritoneum of the proboscis. If Spengel is correct in regarding this organ as derived from the pulsating vesicle of *Tornaria*, it may be compared with the similar vesicle of Molluscan larvæ. These last (e. g. in *Limax*) do not communicate with the vascular system, but with the cavity inclosed between the two mesodermal layers, which Salensky, in *Vernetus*, homologized with the cœlomic cavity. The organ which Bateson regarded as the notochord cannot be compared with the true chord; it probably represents the preoral part of the enteron, and is well developed in correlation with the great development of the preoral lobe. The lacuna in the proboscis appears to have no proper walls, and must not be homologized with the heart.

The vascular system of this species appears to be very simple, the dorsal and ventral trunks alone being developed. The layer of nerve-fibres is under the whole of the integument; its dorsal and ventral thickenings have a simpler relation to the body epithelium than is the case in *B. minutus*. The dorsal central nervous system has no central cavity, no neuropores, and no dorsal cords.

The skeleton, as Spengel rightly supposed, is merely a local thickening of the membrana propria, and has none of the morphological elements described by Marion in *B. Talaboti*. The branchial part of the enteric canal forms a few loops, and the gills have the same structure as in *B. Kowalevskii*. The branchial region divides into two parts—an upper with the epibranchial ridge, and a lower which has the form of a small groove, the base of which is beset with papillæ. This groove is similar to the diverticulum of the segmented portion, and the two may be regarded as the homologue of the endostyle, the hypobranchial groove, and the thyroid gland of the Cyclostomata. The lateral evaginations of the segment-region probably form rudimentary gill-sacs, and may be compared with the peribranchial spaces of Tunicates, and the lateral diverticula of the anterior part of the intestine of larvæ of *Amphioxus*. Behind these is a looped portion; in the second and fourth of these loops there is communication with the exterior by means of pores; of the last there are no less than six in the fourth loop. They are probably to be regarded as rudimentary gill-clefts, without valves or skeleton.

The funnel-shaped organs in the segment have no internal folds, and may apparently be compared with the ectodermal parts of the segmental organs of the first body-segment. Bateson's view that the reproductive organs have some relation to the epidermis is not accepted; these organs consist of a series of peritoneal outgrowths on either side of the body. Each ovary is attached to a hollow stalk, which represents the neck of the outgrowth, and, like it, consists of modified peritoneal cells. The eggs develop in the walls of the sac, in the midst of meso-

dermal cells. The testes are formed of hollow saccules, which consist of an external connective tissue, and an internal epithelium; as their internal surface has no peritoneal investment, the genital cells project directly into the cavity of the sac.

*B. Mereschkowskii* may be regarded as a trochophore provided with a single, first, body-segment, and the cephalic ganglion. It is modified by the possession of certain characters (dorsal nerve-tube, gill-clefts, &c.), which bring it close to the Chordata.

'Challenger' Myzostomida.\*—Dr. L. von Græff has published a supplementary report based on the Myzostomida found by Dr. P. H. Carpenter during the investigations of the Crinoids collected during the voyage of H.M.S. 'Challenger'; seven new forms are described.

#### Echinodermata.

Development of Egg of *Echinocardium cordatum*.†—Herr A. Fleischmann has examined the early stages in the development of this irregular Echinoid. The fertilized ovum is a homogeneous finely-granular sphere of protoplasm inclosed in a vitelline membrane and a rather thick gelatinous envelope. The first cleavage-plane is seen about an hour and a half after fertilization, and segmentation is nearer one pole than the other. The first plane appears first at the animal pole, and later, extends to the vegetative, so that division is first completed at the animal pole. In consequence of the mode of appearance of the second plane there is, for a short time, a three-celled phase of cleavage. The cleavage-cavity next begins to appear, and has at first a somewhat tubular form, but, owing to the closer approximation of the cells of the upper (animal) pole, the cavity takes the form of a truncated cone.

From the very beginning of cleavage the egg loses more and more its distinctly spherical form, and the four cleavage "spheres" are drawn out. The details of cleavage are given, but the result attained is that differences in cleavage have no anatomical or phylogenetic significance.

Renal Organ of Echinoids.‡—Herren P. and F. Sarasin offer a suggestion as to the function of the brownish organ which accompanies the stone-canal of Echinoids, and has had such different uses assigned to it. In *Asthenosoma* the organ is for its whole length traversed by a large cavity; from this there are given off a number of large glandular lobes with narrow lumina. The glandular tubes opening into the chief cavity contain large clear vesicular cells, which, in a striking manner, call to mind the renal cells of Molluscs. The tubes are imbedded in a stroma of connective tissue, in the smaller or larger meshes of which the nutrient hæmolymph circulates. Fine canals lined by regular epithelium are given off from the large glandular lobules, and then make their way towards the periphery, and after a more or less coiled course, pass into larger spaces, which open on the surface of the organ by small orifices into the cœlum; these during life are well ciliated. The authors believe that these infundibular openings of the renal canals correspond to the ciliated infundibula of certain Holothurians, and they believe that they are right in calling them nephrostomata. The well-known

\* Reports of H.M.S. 'Challenger,' Myzostomida (ii.), ix. (1887) 16 pp., 4 pls.

† Zeitschr. f. Wiss. Zool., xlvi. (1883) pp. 131-42 (1 pl.).

‡ Zool. Anzeig., xi. (1888) pp. 217-8.

corpuscles of the cœlom may be sometimes found in considerable numbers in the infundibular ducts.

It is clear that if the Sarasin's view of the function of this organ be correct, the organ must have an efferent duct or ureter: this is to be found in the structure, as to the existence of which authors have differed so much. The causes of the difficulty in detecting it are that it arises from the side of the organ, and that it becomes lost in the remarkable spongy structures filled with cœlomic corpuscles, about which so much has been recently written.

The renal cavity, which is of some size in the lower and middle parts of the organ, is much constricted superiorly. The stone-canal and ureter unite into a common collecting vesicle, which, by means of a narrow canal, passes into the collecting cavity of the canaliculi of the madreporite. The renal cavity ends blindly near the circumœsophageal vascular ring, and the blood-carrying meshes of the connective tissue of the kidney communicate with the lacunæ of the blood-vascular ring. The excretory matters of the blood are alone removed from the body by the ureter. The authors regard the whole kidney as an appendage of the water-vascular system, the excretory nature of which has lately been insisted on by Hartog.

**Remarkable Ophiurid from Brazil.\***—Prof. F. Jeffrey Bell gives an account of an Ophiurid from Itamaraca, the arms of which are about forty times the diameter of the disc. Owing to the fact that all three specimens have lost the covering of their disc, it is impossible to say definitely to what genera these interesting forms belong, but on the supposition that the amount is small, or that the disc is nearly "naked," the species, which is called *sesquipedalis*, is placed in Lütken's genus *Ophionephthys*. It is possible that the loss of the upper surface of the disc is associated with the evacuation of the genital products. Naturalists who may have the advantage of seeing this very long-armed form alive, should carefully observe the phenomena of the restoration of the disc.

**New and Old Holothurians.†**—Prof. H. Ludwig has had the opportunity of examining the sixteen Holothurians collected in Ceylon by the Drs. Sarasin, and he takes the opportunity of suggesting that some recently described species are synonymous with forms already known. Three species from Angra Pequena are also noticed. Eighteen species collected by Dr. Sander, of the German ship 'Prinz Adalbert,' are also enumerated; among them there is a new species of *Pseudocucumis* (*P. Theeli*); the study of this has resulted in a fresh diagnosis of some allied genera; with *Pseudocucumis* Prof. Ludwig would place *Amphicyclus*, as he does not attach as much importance to the presence of an inner circle of smaller tentacles as do Bell and Lampert; he refuses consequently to accept Lampert's division of the Polychirotæ of Bell into the sub-groups of Monocyclia and Amphicyclia.

#### Cœlenterata.

**New Mode of Life among Medusæ.‡**—Mr. J. W. Fewkes gives an account of an extraordinary case of parasitism among Medusæ. Near the anal fin of *Seriola zonata* curious appendages, which reminded him

\* Ann. and Mag. Nat. Hist., i. (1888) pp. 368-70.

† SB. K. Preuss. Akad. Wiss. Berlin, 1887, pp. 1217-44 (1 pl.).

‡ Ann. and Mag. Nat. Hist., i. (1888) pp. 362-8.

of an attached fungus growth, were observed. By the aid of a lens the attached body was seen to be a Hydroid, for which the name of *Hydrichthys mirus* has been proposed. The hydroid forms consist of sexual and asexual individuals, the latter of which are simple flask-shaped bodies without tentacles and with terminal mouths; they may be called filiform bodies, and the sexual persons gonosomes. Neither have a circle of tentacles around the mouth-opening. The medusa-stage (gonophore) has a *Sarsia*-like bell and manubrium, four radial tubes, and four tentacles without appendages.

The loss of tentacles by the hydroid may be ascribed to the parasitic habit. The relation of the medusoid to the *Sarsia*-like group implies degeneration and not phylogenetic simplicity. The polymorphism of the hydroid stages is also an important character. *Hydrichthys* appears to be the nearest known ally of *Velella*. Mr. Fewkes thinks that we may learn from the present case that the true affinities of most Hydroids cannot be definitely made out until both Hydroid and Medusa are studied together.

Medusæ from New England.\*—Mr. J. W. Fewkes gives an account of the Medusæ observed on the coast of Maine and at Grand Manan. The only Physophore captured was *Nanomia cara*, of which little is known; the author was able to make some observations on its development, and to see that the primitive larva preserves the Medusa-form; it "may be supposed to approach more closely the ancestral form of the Siphonophora among other Hydromedusæ than any other medusiform larva." The close homology between a medusiform gonophore and a simple hydroid is such that the author thinks we are justified in regarding the young of *Nanomia* with a float and no primitive hydrophyllium as analogous with the primitive larva of *Agalma*. Mr. Fewkes believes that the ancestral form of all Hydromedusæ, as well as of all the Siphonophora, will be found to be similar to the primitive larva of *Agalma* in its youngest stages. It had the form of a ciliated placenta, with an enlargement at one end and a mouth at the opposite. The enlargement at one end was formed of three layers, wall bell-shaped or gelatinous, and it is this which forms the bell of the Medusæ, the float of *Nanomia*, and the primitive hydrophyllium of *Agalma*. In the fixed hydroid it becomes a base of attachment, in *Rhizophysa* or *Nanomia* a float, and in *Agalma* a covering scale.

*Hydrichthys mirus* is a new genus and species, for which see *supra*. The remarkable genus *Callinema* was rediscovered by Mr. Fewkes, who gives some notes on the anatomy of *C. ornata*[um]; he does not agree with Prof. Haeckel in thinking that it belongs to the genus *Phacellophora*.

New Physophore.†—Mr. J. W. Fewkes describes a new genus of Physophorids—*Plæophysa*—which has interesting morphological affinities with already known genera. The large float is partially covered by a hood-shaped body which is (or appears to be) bound by muscular bands to a globular enlargement of the polyp-stem. There are no nectocalyces nor hydrophyllia. The form of the stem (axis) which ordinarily bears polypites, is reduced to a globular shell, and the nectostem, or part which ordinarily carries nectocalyces, is modified into the hood. *P. agassizii* is the name of the species.

\* Bull. Mus. Comp. Zool. Camb., xiii. (1888) pp. 209-40 (6 pls.).

† Ann. and Mag. Nat. Hist., i. (1888) pp. 317-22 (1 pl.).

A new family, which may be called Plœophysidæ, must be formed for the reception of this remarkable form; its affinities are difficult to make out, but it has close resemblance to the Angelidæ, from which it differs in the characters of the hood. This hood appears to be homologous with the nectostem of other Physophores, which assumes a variety of shapes in certain genera; the forms most nearly approaching it are to be seen in *Pleurophysa* and *Haliphysa*. In the Rhizophysidæ the nectostem is ordinarily reduced to nothing or is wanting.

**New Pennatula from the Bahamas.\***—Dr. G. H. Fowler describes *Pennatula bellissima* sp. n. from the Bahamas. The siphonozooids, which are mainly placed on the ventral surface of the rachis, are specially massed at the bases of the leaves. They are not separable into two types by size or other characters, and are distinguishable from the immature autozooids at the point where the two meet; they have a strong siphonoglyphe at the abaxial end of the stomodœum. The immature autozooids are not provided with tentacles, though they have stomodœa and the usual eight mesenteries; they have a true siphonoglyphe, though that groove is wanting from the mature polyps. As the organ appears to be useless in young buds, it would seem that we have here to do with a case in which asexual ontogeny is repeating phylogeny.

The spicules are long and fusiform, and apparently triradiate in section. The new species appears to be most nearly allied to *P. navesii*, but differs from it in the number of rudimentary leaves, the absence of wartlike protuberances from the concave border of the leaf, the freedom of the mid-dorsal line of the rachis, &c.; the row of immature zooids is characteristic of both forms.

**Actiniæ of Coasts of France.†**—Dr. P. Fischer, in this contribution to the Actinology of the French coasts, deals with the forms observed at Roscoff and at Banyuls. The work is purely descriptive, and the author attempts to remove some of the difficulties which all must have felt who have tried to determine specifically these variable creatures; the modifications observed in different regions are duly noted. Sixty species in all are now known from the French coast, seventeen of which are common to the Atlantic and Mediterranean coasts; many are known in more northern latitudes. Nineteen species are confined to the Mediterranean Sea.

**Gonactinia prolifera.‡**—Herren F. Blochmann and C. Hilger give an anatomical account of this Norwegian Sea-Anemone, the chief interest of which lies in its power of asexual reproduction by transverse fission. This appears to be quite a regular phenomenon. The first sign is the appearance of small, bud-like projections, a little below the middle of the body; these are the rudiments of the new tentacles. They soon exhibit a distinct arrangement in two rows, similar to that of the circumoral tentacles. An oral disc and an œsophageal tube are formed, and above the new circlet of tentacles the body-wall becomes marked by a circular constriction, and grows inwards. Sars once observed three connected individuals.

Various modes of asexual reproduction have now been observed among Actinians. The most ordinary is that first observed by Dicque-

\* Proc. Zool. Soc. Lond., 1888, pp. 135-40 (1 pl.).

† Arch. Zool. Expér. et Gén., v. (1887 [8]) pp. 381-442.

‡ Morphol. Jahrb., xiii. (1888) pp. 335-401 (2 pls.).

mare, in which fragments of various sizes are given off from the base of the body-wall, and grow up into new animals. It is doubtful, however, whether this is a normal process. Longitudinal division has also been observed, though not frequently; division may begin either with the oral disc or with the base. Here again it is not certain that the phenomenon is not due to chance external influences. In some cases, at any rate, the division is not complete as far as the base. Andrus has observed transverse fission in an *Aiptasia*, but he did not think that he there had to do with a normal occurrence. In *Gonactinia* the fission has been observed only in young animals without developed generative organs; similar phenomena have been observed in *Flabellum* and *Fungia*, but here there were certain morphological differences which led Semper to suppose that he had to do with an alternation of generation. In *Gonactinia* there are no such differences, and at present we may rather compare its mode of multiplication with that of *Hydra*, where all the forms finally become sexually mature. Special interest attaches to this mode of reproduction now that Götte has suggested that the young *Scyphostoma* has the essential structure of an Anthozoon. While there are, no doubt, remarkable resemblances between them, there is one important difference. In *Gonactinia* the products of division are exactly alike, but the *Ephyra* which is set free is not the same as the sessile *Scyphostoma*. Moreover, the products of *Gonactinia* may both again multiply by transverse fission, but this is not the case with *Ephyra*. Notwithstanding these differences we may regard this regular division in Actiniae as a further support to the views of Götte as to the connection between the Anthozoa and the Acalephæ.

One case of reproduction by budding was observed in *Gonactinia*.

**Nature of Polyparium.\***—Herr W. Haacke discusses the "tectology and phylogeny" of Korotneff's Anthozoan genus *Polyparium*. The discoverer regarded it as a colony or corm; Ehlers (on theoretical grounds) as the portion of a person; Haacke differs (on theoretical grounds) from both, and would derive the curious form from an ordinary bilateral Anthozoon. He starts from a form like a young *Halcampa*; the conical aboral end is replaced by a broad cylindrical basal disc, and the simple tentacle wreath is supposed to be multiple; the organism is pulled out in breadth, the œsophagus and mouth are supposed to disappear, the tentacles become short, and acquire wide terminal apertures; and lastly the basal disc is supposed to develop a number of suckers—the result would exhibit the external features of *Polyparium*. The author goes on to justify such an interpretation and derivation of Korotneff's genus, but his theoretical arguments are difficult to summarize. It is probably better to await the possible reinvestigation of the animal itself.

#### Porifera.

**Comparative Anatomy of Sponges.†**—In the first of his studies on the Comparative Anatomy of Sponges, Mr. A. Dendy describes *Riddleia* g. n., and *Quasillina* Norman, allied Monaxonid genera. In the former the inhalent and exhalent channels are canalicular, and the flagellated chambers are provided with special inhalent and exhalent canaliculi, while in *Quasillina* the inhalent and exhalent channels are for the most

\* Biol. Centrallbl., vii. (1888) pp. 685-9.

† Quart. Journ. Micr. Sci., xxviii. (1888) pp. 513-29 (1 pl.).

part lacunar, and the flagellated chambers open directly into them. There is, however, some evidence to show that flagellated chambers with and others without special canaliculi may coexist in the same sponge. Both genera are remarkable for the development of the fibrous tissue. In *Ridleya* it is largely developed in the ectosome proper, and in the wall of the oscular tube, where it is arranged in well-defined layers of longitudinal and circular fibres. In *Quasillina* it is almost entirely absent from the ectosome proper, but is well developed in the wall of the oscular tube, where it forms definite annular ridges in which the close-packed fibres (myocytes) have a distinct, wavy outline. The mode of occurrence of the fibrous tissue indicates that its function is a contractile one, or in other words, that the fibres are muscular fibres; the annular bands of fibres around the oscular tube of *Quasillina* are probably to be regarded as sphincter muscles.

With regard to the origin of spicules Mr. Dendy now takes Prof. Schulze's view that the polyactinal type of spicule is the primitive form from which the monactinal type has been derived by abortion of the rays. The swollen base or head of a typical Suberitid spicule, together with the corresponding enlargement of the axial thread, indicates the position where other rays were at one time united with that one which now alone remains. In the typical Suberitidæ and in *Ridleya* all rays but one have disappeared, but their former presence is still indicated by the head of the tylostylote spicules. In *Quasillina* the spicules are still more modified, and the head has, in most cases, disappeared.

It is probable that the lacunar type of canal system, as it occurs in the Monaxonida, with chambers opening directly into wide lacunæ, is less primitive than the canalicular type.

**Chromatology of Sponges.\***—Dr. C. A. MacMunn, out of the twelve species of British sponges examined, found ten to contain chlorophyll; Krukenberg and other observers have figured the dominant chlorophyll band in eight others. Probably Krukenberg † used solutions which were too dilute to show the remaining bands, or examined only thin layers of the solutions. Lipochromes occur in nearly all sponges, and a histohæmatin in seven of the sponges examined. A pigment resembling a floridine (a class of red pigments described by Krukenberg) occurs in *Halichondria rosea*, in addition to chlorophyll, a histohæmatin, and a lipochrome. A uranidine (a class of yellow pigments also described by Krukenberg), occurs in *Grantia coriacea*, in addition to chlorophyll and a lipochrome. This uranidine, like Krukenberg's aplysinofulvin (one of the five pigments of *Aplysina*), and others of the same class was changed by boiling to dark green.

With regard to the chlorophyll present in so many sponges, it was found to resemble plant chlorophyll very closely. The lipochrome constituent or constituents, however, reacted differently from the lipochrome constituents of plant chlorophyll, as it remained unchanged by the action of iodine in iodide of potassium, and the fractional method did not separate the chlorophyll constituents (Hansen's "chlorophyll-green" and "chlorophyll-yellow") so completely as in the case of plant chlorophyll. In these two points it resembles enterochlorophyll, and proves that the chlorophyll is of purely animal origin. Microscopic

\* Journ. of Physiol., ix. (1888) pp. 1-25. Cf. Journ. Chem. Soc. Lond., 1888, Abstr., pp. 619-20. † 'Grundzüge einer vergleich. Physiol. der Farbstoffe,' 1884.

search for unicellular algae, moreover, yielded negative results. The fact that in sponges lipochromes so often accompany chlorophyll, and sometimes replace it, would go to show that the step from a lipochrome to a chlorophyll is not a great one; and it is highly probable that these pigments are concerned in the formation of fatty matters, perhaps from the waste carbonic anhydride given off during the katabolic changes in the tissues, and from the water in which they are bathed; carbohydrates are perhaps similarly formed. This would coincide with the views of Schunck, who regards chlorophyll as a respiratory pigment, but probably a carbonic acid-carrier, not an oxygen-carrier. In sponges, the histohæmatin, when present, has probably the function of an oxygen-carrier.

A chart of spectra, with measurements, accompanies the paper.

**Gemmules of Silicispongizæ.\***—M. E. Topsent describes the occurrence of gemmules in *Chalina oculata*, *C. gracilentia*, *Cliona vastifica*, *Suberites ficus*. They consist of large cellular elements with aggregations of bright granules, and of an envelope of keratode, but they exhibit no foramen nor special spicules. Those of the first-named species occur on the lower part of the firm stalk, and are somewhat complex. Bowerbank seems to have described a *Chalina* with gemmules as a new species, *Diplodemia vesicula*. In *Chalina gracilentia* they occur close upon the substratum; in *Cliona*, close beside the perforated substance; in *Suberites domuncula* and *S. ficus* they have a similar position near the shell or substratum on which the sponge is seated. Carter saw them, and regarded them as arrested ova. Except in *Cliona vastifica* the gemmules become mature in spring; in this species they occur all the year round, and contemporaneously with the sexual reproduction.

**Silicoblasts.†**—Herr Noll describes the silicoblasts of some siliceous sponges. In *Desmacidon bosei* N. he found on the strands of skeletal spicules traces of very large spindle-shaped cells, which seemed to be either spongioblasts or silicoblasts. Similar cells were seen in *Spongilla fragilis*. They inclosed in some cases minute incipient spicules. A cell seems to become elongated, its content becomes thin and clear, the central filament appears as a darker streak quite inclosed by the cell. With the growth of the spicule the protoplasm disappears, leaving in some cases a very thin envelope. In some cases the cells which form the spicules contain two nuclei.

**Survival of Spongillæ after Development of Swarm-larvæ.‡**—Herr M. Weltner has examined the common belief that reproduction causes the death of *Spongilla*. After various failures in the attempt to keep alive for a long time examples of *Ephydatia fluviatilis*, he found it easy of accomplishment with young Spongillæ reared from larvæ. A decidedly female *Spongilla* was kept alive for nearly four months after the issue of the last larva. In opposition to the statements of Lieberkühn and Metschnikoff, it was found that dermis, excurrent tubes, and flagellate chambers and canals do not completely disappear in the perennial sponges of the Togelsee. The author agrees with Götte that in *E. fluviatilis* there can be no question of a decided seasonal difference, or of a true alternation of generation, such as, according to Marshall, occurs in *Spongilla lacustris*.

\* Comptes Rendus, cv. (1888) pp. 1298-1300.

† Biol. Centralbl., vii. (1888) pp. 767-8 (60 Versamml. Deutsch. Natmf. Wiesbaden, 1887).

‡ Ann. and Mag. Nat. Hist., i. (1888) pp. 340-3.

'Challenger' Sponges.—Messrs. S. O. Ridley and A. Dendy report\* on the Monaxonid Sponges collected by H.M.S. 'Challenger.' In the introduction a full account is given of the spicules. *Cladorhiza tridentata* (from a depth of 1600 fathoms) has imbedded in its soft tissues a large number of small yellow globular bodies; each of these consists of a central, more deeply staining and granular portion which is surrounded by and imbedded in a matrix of faintly staining, perfectly hyaline, ground substance. Other peculiar cup-shaped bodies occur towards the periphery of the sponge, and the authors suggest that the whole structure may be phosphorescent, and serve to attract the minute organisms on which the sponge feeds. The order Monaxonida is divided into the two suborders Halichondrina and Clavulina; the former consists of the Homorhaphidæ, Heterorhaphidæ, Desmacidonidæ, and Axinellidæ; the latter of the Suberitidæ and Spirastrellidæ. More than two hundred species or well-marked varieties are described, twenty-four of which were found at depths between one and two thousand fathoms; those from great depths are, almost without exception, beautifully symmetrical, while shallow-water forms are characteristically shapeless, or at most digitate or ramose. The Hexactinellida † are reported on by Prof. F. E. Schulze, who gives an atlas of 104 most beautiful plates. Twenty new genera and sixty-five new species are described; the greatest depth at which they were found was 2900 fathoms, from which *Bathydorus fimbriatus* was taken.

#### Protozoa.

Bütschli's Protozoa.‡—Since we last gave a notice of this important work parts 35-46 (pp. 1089-1376), with plates 51-71, have been published. The history of the progress of our knowledge of the Infusoria is completed, and a bibliography containing 822 titles is appended. The account of the first sub-class—that of the Ciliata—is commenced, its general morphology being first dealt with; this is followed by descriptions of the ectoplasm and its differentiations, in which, *inter alia*, the interesting question of the striation sometimes observed is discussed; the locomotor organs of the ectoplasm and allied structures are next described, and here, in addition to pseudopodia and tentacular processes, cirri, membranellæ, and undulating membranes are noticed. Part 46 breaks off in the midst of an account of the mouth and gullet considered as differentiations of the ectoplasm.

Multinucleate Infusoria.§—Prof. A. Gruber describes the various multinucleate Infusoria which he has observed, and gives a detailed account of the division of *Holosticha scutellum*. When the process begins the numerous small nuclei unite; beside the large nucleus thus formed a small accessory nucleus for the first time appears; the latter Gruber believes to be due to the fusion of extremely small previously invisible elements. The accessory body divides first, then the large nucleus. All the divisions of the latter exhibit nuclear figures previously described. A transverse constriction of the body becomes more and more marked. Each half contains the division products of large and

\* Reports of H.M.S. 'Challenger,' Monaxonida, lix. (1887) 273 pp., 51 pls.

† Reports of H.M.S. 'Challenger,' Hexactinellida, liii. (1887) 513 pp., 104 pls.

‡ Bronn's 'Klassen u. Ordnungen. Protozoa,' by Dr. O. Bütschli, parts 35-46, Leipzig and Heidelberg, 1887-8.

§ Ber. Nat. Gesell. Freiburg, iii. (1888) pp. 58-69 (2 pls.).

small nuclei, which then exhibit a long series of further divisions. The divisions of the accessory elements do not keep pace with those of the larger nuclei. In each half of one individual just before separation Gruber observed thirty-two division products of the large nucleus, and the number is increased after separation. The accessory elements seem to divide again and again, till too small to be seen.

*Folliculina ampulla*.\*—Prof. K. Möbius has reinvestigated that interesting Infusorian (*Flaschentierchen*) *Folliculina ampulla*, specimens of which he found on the woodwork of Kiel harbour. The nature of the individual animals is described. The lobes of the anterior funnels bear ciliated combs (*pectinellæ*) and ciliated lappets (*membranellæ*); the mouth is guarded by a crescentic valve; the "gullet" is conical, and leads directly into the digestive plasma. A dorsal anterior anal opening is present. The nucleus is posterior and necklace-like.

Möbius describes the peculiar budding process which results in multiplication. The young form remains until mature connected with the parent by a strand. The bud has no developed funnel-lobes nor protective sheath. It differs from a Metazoan germ in being almost as large as the individual parent. The duration of the free life of the young form was not discovered.

Lastly, the author discusses the "psychical life" of *Folliculina*. He maintains the necessary supposition of a low grade of "consciousness," and on this subject submits some instructive considerations.

Fresh-water Infusoria of the United States.†—Dr. A. C. Stokes has published a preliminary contribution towards a history of the fresh-water Infusoria of the United States. The forms identical with European species are mostly recorded by name only, while American genera and species are much more fully characterized. Of a number of these forms we have already given more extended notice.

New Foraminifera.‡—Dr. H. Blanc describes an interesting new species of *Gromia* (*G. brunneri*) from the mud at the bottom of Lake Geneva. The colour was pale yellow, the form varied with size from oval or spherical in the larger, to fusiform or bottle-shaped in the smaller specimens. There is a strong opaque shell, with oval or circular aperture, composed of small vegetable bodies cemented together, sometimes along with quartz-grains. Under this there is also a peculiar chitin-like, internal membrane or shell. Fine pseudopodia flow from the aperture, and cover the shell. They lengthen, anastomose, and exhibit currents. Part of the external protoplasm probably forms the cement of the shell. The vacuoles are small and not numerous. Whether any were contractile could not be determined. The nucleus has a peculiarly thick membrane, a zone of globules surrounding this internally, and granules of chromatin. With high power it exhibits a reticular appearance. The author finally discusses the peculiar habitat and emphasizes the distinctiveness of this interesting new *Gromia*.

*Psorospermium Haeckelii*.§—Dr. A. Wierzejski has examined this interesting parasite. He finds that, in the quiescent condition, it is inclosed by thin capsules; the outermost is very finely striated, and is

\* Biol. Centralbl., vii. (1888) pp. 721-3.

† Journ. Trenton Nat. Hist. Soc., i. (1888) pp. 71-345 (13 pls.).

‡ Rec. Zool. Suisse, iv. (1888) pp. 497-513 (1 pl.).

§ Zool. Anzeig., xi. (1888) pp. 230-1.

distinctly hyaline; it does not take up any colouring matter, and is, to all appearances, produced by the tissue of the host. The median capsule appears to be made up of separate strong plates, laid down somewhat irregularly, and having fine ducts between them; this capsule stains very intensely with anilin-dyes. The internal capsule is the thinnest, and like the other two is transparent; it does not stain with carmine or anilin. Treatment with iodide of potassium and sulphuric acid shows that the median capsule consists of true cellulose, and it may be, therefore, that the parasite is a plant and not an animal.

*Megastoma entericum*.\*—MM. B. Grassi and W. Schewiakoff have an account of the structure of this protozoic parasite of mammals. The latter author is alone responsible for the views enunciated as to the systematic position of the animal. He believes it to be closely allied to *Hexamitus inflatus* Duj., and to *Giardia agilis* of Künstler. They agree essentially in the arrangement of the flagella, but *Megastoma* is distinguished by the development of its peristome, which has brought about some change in the place of insertion of the flagella, and in the form of the nucleus.

The parasite has been found in a number of Rodents, and in Cats, Dogs, and Sheep. It lives chiefly in the duodenum and jejunum, and is found encysted in the colon. By means of its peristomial excavation it attaches itself to the epithelial cells of the villi, at the cost of which it lives; while it is dangerous as preventing normal absorption. From the observations of Grassi it appears probable that *Megastoma* may produce diarrhoea and anemia in man.

\* Zeitschr. f. Wiss. Zool., xlv. (1888) pp. 143-54 (1 pl.).



## BOTANY.

## A. GENERAL, including the Anatomy and Physiology of the Phanerogamia.

## a. Anatomy.\*

## (1) Cell-structure and Protoplasm.

Division of the Nucleus, Cell-division, and Impregnation.†—Prof. E. Strasburger has continued his observations on the changes which take place during the division of the nucleus in vegetable and animal cells. He adopts Schwarz's terminology of *linine* for the substance of the hyaloplasmic filaments of the nucleus in a state of repose, *chromatine* for the substance of the granulations. The filaments of linine are composed of numerous folds, and anastomose so frequently in the nucleus when in a state of repose, that it presents the appearance of a web of close meshes in which the threads cannot possibly be followed throughout their course. The nuclear cavity does not, however, as the author previously supposed, contain only a single filament. The use of eau de Javelle shows that the division of the nucleus is not accompanied by the segmentation of a single filament, but by the dissociation of filaments already distinct.

The filaments of the spindle are always formed, in the higher plants, at the expense of the cytoplasm which has penetrated into the nuclear cavity, as has been shown also by Guignard. The changes which take place in the nuclear filaments, as well as the movements which they perform, are of an active nature, and the poles serve only to regulate this movement. The movements which the filaments execute in the knot-phase ("phase du peloton") are independent of the future poles, showing that the filaments are endowed with forces of their own, capable of modifying their structure and of changing their position. While this phenomenon is proceeding, the nuclear membrane is still intact. The two poles of the future spindle are formed in the surrounding cytoplasm during the phase of lax knot. After the formation of the bundle and of the nuclear plate, the segments double themselves where they have not done so previously. The secondary segments of each daughter-nucleus approach one-another, and the surrounding cytoplasm envelopes them with a membrane; no other elements take part in the formation of the daughter-nuclei.

There can be no doubt that, in the higher plants, the cytoplasm enters into the nuclear cavity for the purpose of forming the spindle-fibres. The spindle filaments do not persist in the form of primary connecting threads between the secondary segments; and it is only at a later period that they receive an addition of secondary filaments at the expense of the cytoplasm entering between their interstices. The whole mass of filaments usually separates later from the daughter-nuclei, and forms between them a lenticular body surrounded by the cytoplasm. When the cells are filled with cell-sap, the cytoplasm finally forms around the connecting filaments only a tube with more or less thin wall,

\* This subdivision contains (1) Cell-structure and Protoplasm; (2) Other Cell-contents (including Secretions); (3) Structure of Tissues; and (4) Structure of Organs.

† Morot's Journ. Bot., ii. (1888) pp. 81-91.

its edges resting on the masses of cytoplasm which surround the daughter-nuclei. For this tube Strasburger proposes the term *connecting-tube*.

The nucleoli disappear during these changes at an earlier or later period, and take no important part in the nutrition of the nuclear filaments. The chemical changes which take place in the elements of the cellular plate may possibly be due to the influence of the substance of the nucleoli. In cells filled with cytoplasm the cellular plate soon stretches across the whole width of the equatorial plane, and the transformation of the dermatosomes into membrane progresses rapidly from the centre towards the periphery. The formation of cell-wall is therefore entirely dependent on the presence of a nucleus.

Prof. Strasburger finally discusses the question whether the male and female organs in the act of impregnation have the same number of nuclear filaments. He believes that this is the case in the higher plants, and also in the animal kingdom, as shown by observations on nematodes, and that the participation of an equal number of nuclear filaments in impregnation is a very general fact in the organic world; but it is certainly not without exception. In *Arion empiricorum*, for example, according to Platner, the number and volume of the nuclear filaments are less in the spermatie nucleus than in that of the oosphere. Union of the nuclei he believes to be essential to the act of impregnation.

**Relation between the Function and Position of the Nucleus.\***—Dr. E. Korschelt calls attention to the researches of Haberlandt † on this subject, and confirms, from corresponding facts in the animal kingdom, his conclusion that the nucleus is to be found in that part of the cell which has to supply the greatest portion of the food-material for a growing organ. His examples are taken from the position of the germinal vesicle in the ovum of insects, which (in *Forficula* and *Dytiscus*) is to be found, according to circumstances, nearest to that part of the ovum in which an absorption of new substances, and very probably also an assimilation of them, takes place on the part of the ovum. Other examples to a similar effect are adduced.

**Permeability of Protoplasm. ‡**—In continuation of his investigations on the plasmolysis of Algæ, § Dr. J. M. Janse distinguishes between two forms of the permeability of protoplasm for water—*intrameability*, or the capacity of the protoplasm to allow of the passage of certain substances into the vacuoles; *extrameability*, the capacity to allow of their exit from the vacuoles. The plants experimented on were chiefly *Chætomorpha ærea* and *Spirogyra nitida*, also the epidermal cells of *Curcuma* and *Tradescantia*.

The use of very dilute solutions of various substances—sodium chloride, potassium nitrate and sulphate, cane-sugar, &c.—and then staining with a solution of diphenylamin in concentrated sulphuric acid, showed that the protoplasts of all the plants examined were intrameable for these substances; and further, that when the protoplast is intrameable it is not also extrameable. The parietal utricle (Hautschicht) is, on the other hand, both intrameable and extrameable; this is shown in the excretion of sugar from nectaries, in the secretion and absorption in the

\* Biol. Centralbl., viii. (1888) pp. 110-8 (8 figs.).

† See this Journal, 1887, p. 980.

‡ Versl. Meded. K. Akad. Wetensch. Amsterdam, 1888, pp. 332-436 (1 pl.).

§ See this Journal, *ante*, p. 93.

glands of *Drosera*, and especially in the processes which accompany the aggregation of protoplasm, the transport of water and nutrient substances, and the absorption of nutriment by young seedlings out of the endosperm. The phenomena which accompany the movements in the leaves of *Mimosa* cannot, in the opinion of the author, be explained by the expulsion of pure water out of the cells of the pulvinus, but only by the power of extrameability of the protoplasts.

The cause of the intrameability of protoplasts requires further experiments for its determination.

**Albuminous reaction of Cell-wall.\***—Herr A. Fischer disputes the validity of Wiesner's and Krasser's demonstrations † of the presence of albumen in the cell-wall, on the ground that a red coloration with Millon's reagent is by no means so certain a test for albumen as those writers suppose. In the leaves of many species of Bromeliaceæ, he finds not only the epidermis, hypoderma, and sieve-tissue, but all the unligified cell-walls, even those of the chlorophyll-tissue, coloured by this reagent, the very same unligified cell-walls being all coloured deep-blue by chlor-zinc-iodide. The tint with Millon's reagent is not precisely that produced by undoubted albuminoids, but is rather pink than scarlet or flesh-coloured. It is obvious that the red staining takes place uniformly throughout the whole of the cell-wall, which would not be the case if it were due to strands of protoplasm. Fischer finds, moreover, that the red-staining with Millon's reagent does not manifest itself in very young tissues, as would be the case were it due to protoplasm, and concludes that it may probably be caused by tyrosin, or some other product of the decomposition of albumen.

In reply to this criticism, Herr J. Wiesner remarks ‡ that his object has not been simply to demonstrate the presence of an albuminoid in the cell-wall, but to support the view that, at all events up to a certain period, the cell-wall is a living constituent of the cell itself, deriving that character from a proportion of protoplasmic substance which enters into its composition. In support of this view, he does not depend only on the reaction with Millon's reagent.

To this Fischer again replies, § repeating his objections to Krasser's and Wiesner's micro-chemical tests for the presence of albuminoids.

In a further communication, || Herr F. Krasser comments on Klebs's arguments on the presence of albuminoids in the gelatinous sheath and cell-wall of the *Zygnemaceæ*, ¶ which he considers not conclusive, although the conclusion arrived at is probably correct.

**Pleochromism of coloured Cell-walls.\*\***—According to Herr H. Ambronn, there are two kinds of pleochroistic cell-walls; those which are already coloured in nature, and those in which the colour is brought out artificially. The former are comparatively rare; they occur especially in the skin of some seeds, of which the pigment is not in the cavity, but in the cell-wall. The testa of *Abrus precatorius* furnishes a good example. In the parts which surround the umbo, the radial walls of the palisade-cells are violet; in the other parts of the

\* Ber. Deutsch. Bot. Gesell., v. (1887) pp. 423-30.

† See this Journal, 1887, p. 981.

‡ Ber. Deutsch. Bot. Gesell., vi. (1888) pp. 33-6.

§ *Ibid.*, pp. 113-4.

|| Bot. Ztg., xlv. (1888) pp. 209-20.

¶ See this Journal, 1887, p. 410.

\*\* Ber. Deutsch. Bot. Gesell., vi. (1888) pp. 73-84 (2 figs.).

seed red. If these cell-walls are examined optically by a contrivance described in the paper, it is seen that when the plane of oscillation of the rays of light is placed parallel to the longer axis of the actual ellipse of elasticity, the smallest amount of absorption takes place, the largest if it is placed in the direction of the shorter axis.

(2) Other Cell-contents (including Secretions).

**Sphærocrystals.\***—Dr. P. Baccarini has investigated the structure and properties of the sphærocrystals formed by precipitation by alcohol, especially in *Bignonia venusta* and other species of Bignoniaceæ, *Campanula Cervicaria*, *Trachelium ceruleum*, *Specularia Speculum*, *Daphne Laureola*, and *Anagyris fœtida*. In *Bignonia venusta* he finds them in all parts of the plant, floral as well as vegetative, especially during the period of flowering. They are insoluble in alcohol, in water, whether cold or hot, in ether, in chloroform, in benzol, and in glycerin. Glacial acetic acid, picric, citric, oxalic, and tartaric acids have no effect on them. Osmic acid of 1 per cent. turns them brown, but very slowly; chromic acid of 5 per cent. causes disintegration in some hours at the ordinary temperature, more rapidly when hot. Concentrated sulphuric acid destroys them instantly; dilute hydrochloric acid has no effect upon them even when boiling; dilute nitric acid has a feeble, when concentrated a very powerful action. A solution of potash of from 5 to 10 per cent. dissolves them rapidly. The sphærocrystals from the other species examined agree with those of *Bignonia* in their general properties, but their distribution in the plant is much more limited.

**Nectar of Rhododendron.†**—Sig. F. Tassi records the results of analyses made by Sig. C. Grimaldi of the nectar secreted by the floral glands of *Rhododendron arboreum*. He finds it to consist of 92·1 per cent. volatile, and 7·9 per cent. dry substance. The chief ingredient of the latter appears to be an invert-sugar, with a divergence of 1·5° to the left. This is mixed with a nitrogenous substance, and with traces of calcium and potassium sulphates and chlorides. Inoculated into a frog, the secretion had strong toxic properties.

**Tannin in the Crassulaceæ.‡**—According to Herr E. Wagner, tannin is especially abundant in plants belonging to this natural order. It occurs only in the parenchymatous tissue, and always dissolved in the cell-sap; but its distribution in the fundamental tissue varies greatly in nearly related species. The structures which contain the largest quantity are the secondary cortex, the bundle-sheath, and the epidermis or one or two layers lying immediately beneath it; it was not found in the growing point, the first rudiments of the leaves, the cambium, or the starch-sheath. The cells containing tannin do not usually differ materially from those which surround them in size; but there is a strong contrast between them and those which contain starch, they often have thicker walls than the other cells of the same tissue. In the species of Crassulaceæ examined, it does not transfer itself from one part of the plant to another, but remains in the cells where it is formed until the death of the plant.

\* Malpighia, ii. (1888) pp. 1-18.

† Tassi, F., 'Del liquido secreto dai fiori del *Rhododendron arboreum*,' 17 pp., Siena, 1888. See Bot. Centralbl., xxxiv. (1888) p. 50.

‡ Wagner, S., 'Ueb. d. Vorkommen u. d. Vertheilung des Gerbstoffes bei d. Crassulaceen,' 44 pp., Göttingen, 1887. See Naturforscher, xxi. (1888) p. 70.

**Occurrence of the Elements of Sugar of Milk in Plants.\***—According to M. A. Müntz, the mucous substances of plants—gums, mucilages, pectic substances, &c.—contain, in the products of their doubling, galactose identical with that of sugar of milk; and these mucous substances exist in vegetable food-materials in such quantities that they are able to supply the galactose which enters into the composition of the sugar of milk secreted by the mammary glands of herbivorous animals.

**Development of some Secretions and their Receptacles.†**—Herr A. Tschirch calls attention to the different origin, in the general way, of gum, which is a pathological product and the result of the disorganization of the cell-wall, and resin, which is formed in the cell-cavity in the bark and wood, diffuses through the cell-walls, and is secreted into the intercellular passages by a thin-walled tissue, the “secreting epithelium,” which clothes the schizogenous canals. There are, however, instances in which gum or mucilage occurs as a cell-content, as in *Orchis*, or is excreted into schizogenous receptacles, as in the Cycadææ; and, on the other hand, instances in which the cell-wall takes part in the formation of ethereal oils and resins, as in the lysigenous oil-passages of the Aurantiacææ.

The author then describes the method of formation of copaiva-balsam, which takes place, not in schizogenous, as sometimes described, but in lysigenous canals. The absorption of the cell-walls, and the formation of the resin, commence in the parenchyma of the wood, advancing from there to the medullary rays, the libriform, and the vessels. In *Styrax Benzoin* also, the source of the benzoin of commerce, the resin is not formed in schizogenous canals, but originates in the medullary rays, advancing from them to the surrounding phloëm-parenchyma, and finally to the bast-cells and sclereides. The same is, in general terms, the history of the formation of the resin in *Abies*, *Thuja*, and *Dipterocarpus*.

In the so-called myrrhs, on the other hand, species of *Balsamea* and *Boswellia*, the gum-resin is always formed in schizogenous receptacles or in true cells.

### (3) Structure of Tissues.

**Secretory Canals and Secretory Reservoirs.‡**—M. A. Leblouis gives a detailed account of the origin and development of secretory canals and secretory reservoirs.

The paper is divided into four portions:—(1) Those families which possess only secretory reservoirs:—e. g. Myoporææ, Myrtacææ, Rutacææ, and Myrsinææ. (2) Those which possess both secretory canals and secretory reservoirs:—e. g. Compositææ, Hypericacææ, Clusiacææ, and Aroidææ. (3) Those which possess only secretory canals:—e. g. Cannææ, Anacardiææ, Sinarubcææ, Pittosporææ, and Butomeææ; and (4) Study of laticiferous vessels.

In conclusion, the author states that the tissue which has been studied in this paper is a living tissue. It arises always in the same manner, by division and dissociation, and not by the destruction and resorption of cells. It is a secretory tissue, and it presents itself in two

\* Ann. Chim. et Phys., x. (1887). See Bull. Soc. Bot. France, xxxv. (1888) Rev. Bibl., p. 11.

† Ber. Deutsch. Bot. Gesell., vi. (1888) pp. 2-13 (1 pl. and 1 fig.).

‡ Ann. Sci. Nat. (Bot.), vi. (1887) pp. 245-330 (5 pls.).

forms: that of the canal, and that of the reservoir; in the one case as in the other, it is generally surrounded by a protecting sheath. The two forms may be met with either isolated or united, but one never finds reservoirs in roots, although they are often abundant in the leaves.

**Secreting Canals of Umbelliferæ and Araliaceæ contained in the Phloem.\***—It is well known that to each vascular bundle in the leaf-stalk of Umbelliferæ there is in general a corresponding collenchymatous bundle beneath the epidermis, below which runs a secreting canal, this canal sometimes originating from a common source in the cambium with the collenchymatous bundle. In addition to these canals, Herr C. Müller finds, in the phloëm portion of each bundle, canals, varying in number according to its strength, which cannot in any case belong to the pericycle. These were observed especially in *Astrantia* and the allied genus *Hacquetia*. They are always closely associated with those in the collenchyma. Their size and the number of secreting cells surrounding each canal vary with the species. Their origin does not appear to be always the same. The cavity of the secreting cells is usually much larger than that of the adjacent phloëm-cells, and the outline of their cell-wall much sharper.

Herr Müller gives a list of a large number of species of Umbelliferæ in which these phloëm-canals were observed; the highest number observed in a single phloëm was eleven. The number of secreting cells belonging to each canal varied between two and nine. In a smaller number of species of Umbelliferæ the most careful observation failed to detect the presence of phloëm-canals.

In the Araliaceæ phloëm-canals were found in the leaf-stalk of a number of species; but they were usually less numerous than in the Umbelliferæ, mostly only one canal in each phloëm.

**Influence of the Turgidity of the Epidermal Cells on the Stomata.†**—According to Herr R. P. C. Schäfer, the opening and closing of the pore of the stoma is due to the relative intensity in the action of two opposing forces,—the turgidity of the guard-cells, and the smaller turgidity of the adjoining cells of the epidermis. The stomatic apparatus exercises an independent function of its own; and the author contests the theory that the guard-cells are compressed by an external force originating in the turgidity of the adjacent epidermal cells. In the stomata of *Azolla* the opening and closing of the pores takes place in the ordinary way, although the guard-cells are destitute of the thickening-bands which are elsewhere characteristic of them.

**Anomalous Cells in the Interior of the Tissue of Fossil Plants.‡**—Prof. W. C. Williamson describes the occurrence of “intrusive” cells lodged in the interior of “host-cells” in the remains of plants from the coal-measures. They occur in parenchymatous tissue, in the interior of scalariform vessels or tracheïdes, and within macrospores belonging to the Lycopodiaceæ. In the case where they occur within vessels they appear to be genuine examples of thylosis; those found in paren-

\* Ber. Deutsch. Bot. Gesell., vi. (1888) pp. 20–32 (1 pl.).

† Schäfer, R. P. C., ‘Ueb. d. Einfluss des Turgors d. Epidermiszellen auf d. Function d. Spaltöffnungsapparates,’ 45 pp., Berlin, 1887. See Bot. Centralbl., xxxiv. (1888) p. 49.

‡ Ann. of Bot., i. (1888) pp. 315–23 (1 pl.).

chymatous tissue may possibly be of an algaoid character; it is much more difficult to account for the cellular appearance of the contents of macrospores.

**Periderm of the Leguminosæ.\***—M. H. Douliot states that in a branch of *Myroxylon Pereira* of one year's growth a periderm formed exteriorly of centripetal cork-layers may be seen, the cells of which are tabular, and preserve their thin appearance; there is also a centrifugal phelloderm somewhat less abundant. The case of the exodermic (sub-epidermic) periderm may be seen in a number of genera. In *Hymenaea Courbaril* the cork remains thin and the cells tabular, the tangential septa being nearer one another than the radial divisions of the mother-cells of the periderm. The phelloderm is composed of two or three layers of cells, and the cork of about a dozen. There are two groups of Leguminosæ in which the periderm is formed in the cortex; and in certain species of this natural order the periderm is pericyclic. A good example of this may be seen in *Soja hispida*.

**Anomalies in the Structure of the Roots of Dicotyledons.†**—Sig. C. Avetta distinguishes between two types of anomalies in the roots of Dicotyledons:—(1) Those produced by the generating zone due to an inequality in the proportion and nature of the secondary tissues formed by the cambial zone at various points in the circumference; and (2) Those produced by the pericycle, due to the formation of new collateral bundles in the secondary parenchyma, resulting from the generating activity of this pericycle. Under each type a number of special cases are described. One of the varieties of the second type, occurring in the Polygonaceæ, affords the only example of supernumerary bundles formed in a centripetal direction.

**Comparative Anatomy of Malvaceæ, Bombaceæ, Tiliaceæ, and Sterculiaceæ.‡**—M. A. Dumont states that among the Malvaceæ, the genus *Malva*, and especially *M. oxyacanthoides*, may be taken as representing the fundamental primitive type. The secondary liber is sharply divided into layers; the three cortical zones, the pith, the epidermis, and the mesophyll of the leaves, contain numerous gummy elements. In this family the essential characters undergo from one species to another certain modifications and gradual attenuations, corresponding to the form and disposition of the reproductive organs. The different species of the family thus form a descending series.

In conclusion, the author states that Malvaceæ, Bombaceæ, Tiliaceæ, and Sterculiaceæ so closely resemble one another in the structure of their stems and their leaves, and in the organization of their flowers and their fruits, that an anatomist would not hesitate to unite them in one and the same natural family. By the help of anatomy, the tribes may be divided into secondary groups, and these secondary groups ought to be considered as groups containing a certain number of species in which the characters have undergone modifications of about the same value from that of the fundamental type.

\* Morot's Journ. Bot., ii. (1888) pp. 71-6 (7 figs.).

† Ann. R. Ist. Bot. Roma, iii. (1887). See Morot's Journ. Bot., ii. (1888) Rev. Bibl., p. 9.

‡ Ann. Sci. Nat. (Bot.), vi. (1887) pp. 129-246 (4 pls.).

## (4) Structure of Organs.

**Roots of Araceæ.\***—Herr M. Lierau has examined the structure of the roots in 46 genera and about 130 species of Araceæ.

The epidermis usually consists of a single layer in the terrestrial species; occasionally there are two, three, or even four layers of cells. The root-hairs are developed from the outer layer, and are either simple or forked, but never thickened like those of many epiphytic orchids. In the epiphytic species the epidermis is replaced by a root-sheath or velamen, usually thin-walled, but consisting, in some species of *Anthurium*, of several layers of thickened tracheides. The velamen is often only a temporary structure. It is always separated from the cortical parenchyma by a protecting sheath or outer endoderm, easily recognized by the fine striation of its suberized walls on longitudinal section, and the wavy appearance of the walls on tangential section. This outer endoderm is very commonly a phellogen-layer, passing over later into cork; in some genera it disappears altogether with the velamen.

The cortex of the root is more or less permeated by large air-passages in the aquatic or paludose species. Almost all possess raphides, and bundles of crystals are found in some cases. Receptacles both for secretion and excretion abound, such as the oil-receptacles in *Acorus*, the tannin-cells in *Anthurium*, latex-vessels, and resin-passages. Spicular cells in the intercellular spaces occur only in the Monsteroideæ. An inner endoderm was found in the root of all Araceæ examined, and is usually somewhat suberized. The axile fibrovascular bundle is almost always of typical structure.

**Mechanical Protection of Bulbs.†**—Herr F. v. Tavel describes the mode in which the tissue of bulbs which is used as a store-house for reserve food-material is protected against pressure or impact throughout, in species belonging to the genera *Crinum*, *Brunsvigia*, *Allium*, *Gagea*, and *Narcissus*. These contrivances have no relation with the systematic position of the species. They consist in most instances of steriodes, which may be collected into a sclerenchymatous layer of cells. Their special development depends on the nature of the climate, and of the injurious influences against which the particular bulb has to be protected.

**Floating-roots of *Sesbania aculeata*.‡**—Dr. D. H. Scott gives the following as the results of his examination of the floating-roots of *Sesbania aculeata* Pers., a plant belonging to the papilionaceous tribe *Galegææ*. (1) The floating tissue of the roots of *Sesbania* is a secondary cortical structure, arising from a phellogen. (2) This tissue, though falling under the definition of periderm, differs from cork in its permanently living cells, its non-suberized cell-walls, and its large intercellular spaces, in which alone air is contained. In all these respects it agrees with the floating-tissue of the stem of *Neptunia oleracea*. (3) The phellogen originates immediately outside the endoderm, thus differing from the phellogen of most roots with typical periderm.

\* Lierau, M., 'Beitr. z. Kenntniss d. Wurzeln d. Araccen,' 37 pp. and 1 pl., Breslau, 1887. See Bot. Centralbl., xxxiv. (1888) p. 53.

† Ber. Deutsch. Bot. Gesell., v. (1887) pp. 438-58 (2 pls.).

‡ Ann. of Bot., i. (1888) pp. 307-13 (1 pl.).

**Tubercles on the Roots of Leguminosæ.**—M. P. Van Tieghem\* discusses the origin, structure, and morphological nature of the radical tubercles of Leguminosæ. Like the rootlets, they originate in the pericycle of the mother-root, opposite the woody bundles if there are more than two, and on each side of them if there are less than two. At the same time the endoderm, and sometimes also several of the internal cortical layers, increase, and their cells divide so as to envelope the rootlet. By their origin, and by their disposition, radical tubercles may be said to be only rootlets that have enlarged. Sometimes the tubercles possess two, three, or four distinct central cylinders inserted the one above the other on points on the central cylinder of the mother-root, opposite the same woody bundle. In this case the tubercle may be said to be formed from a compound rootlet.

Sig. P. Pichi† regards the Y-shaped bodies found in the tubercles of the roots of *Melilotus alba* as probably spores. He describes also the occurrence of hyphæ in the corresponding structures of a large number of species belonging to the Leguminosæ.

**Leaves of Bupleurum.**‡—Herr P. Klausch classifies the leaves of the various species of this genus of Umbelliferae under three heads:—grass-like; elliptic; and those with reticulate venation; in addition to the monotypic *B. difforme*: the special form of leaf being adapted to the external conditions of climate and habitat of the species. In many cases the epidermis of the two surfaces of the leaf is quite alike, the internal structure of the leaf bearing a striking resemblance to those of Monocotyledons.

**Anatomical Structure of the Leaves of Orchideæ.**§—Dr. M. Möbius discusses the structure of the leaves in different genera of Orchideæ, and the bearing of the characters thus obtained on the division of the order into tribes as proposed by Pfitzer. He finds in his observations a support in the general way for the classification proposed. The characters to which his observations chiefly refer are: the degree of cuticularization of the epidermis, and the presence or absence of trichomic structures; the presence or absence of hypoderma and of sclerenchymatous bundles or fibres; the degree of development of the bast in the vascular bundles; the differentiation of the epidermis; and the presence or absence of stomata on the two sides of the leaf, &c.

**Influence of Climate on the Cuticularization and Thickening of the Leaves of some Coniferæ.**||—Herr F. Noack finds, from observations on the leaves of a number of Coniferæ, chiefly species of *Pinus* and *Picea*, that they owe their great power of resistance to the effects of climate, partly, like those of other evergreen plants, to the extraordinarily strong cuticularization and thickening of the walls of the epidermis; partly also to the lignification of larger or smaller portions of the cell-walls. In *Picea* various degrees of this lignification are exhibited, increasing with the increase of latitude in which the trees grow, or with the height above the sea-level.

\* Bull. Soc. Bot. France, xxxv. (1888) pp. 105-9.

† Atti Soc. Tosc. Sci. Nat., vi. (1888) pp. 45-7. Cf. this Journal, ante, p. 251.

‡ Klausch, P., 'Ueb. d. Morphol. u. Anat. d. Blätter v. Bupleurum,' 30 pp. and 2 pls., Leipzig, 1887. See Bot. Centralbl., xxxiv. (1888) p. 169.

§ Pringsheim's Jahrb. f. Wiss. Bot., xviii. (1887) pp. 530-607 (4 pls.).

|| Ibid., pp. 519-29 (1 pl.).

**Bracts of Cruciferæ.\***—M. Beauvisage points out that the absence of bracts from the inflorescence of Cruciferæ is not nearly so constant a character as is usually stated in text-books. In the wall-flower a triangular elevated patch at the base of each pedicel represents the entirely adnate bract.

**Physiological Anatomy of Stipules.†**—Herr O. Schultz classifies stipules, from a physiological point of view, under three heads:—(1) those which serve for protection; (2) those which serve for nutrition, there being also transitional forms between these two; and (3) those which have become abortive and functionless. To these may be added those which are transformed into bud-scales, and those which are transformed into ochreæ.

Those stipules which serve for nutriment or assimilation make their appearance at the same time as the leaves, and endure as long; protection against freezing is often afforded by the presence of anthocyan in the cells, giving them a red colour. The anatomy of stipules of this kind agrees in almost all respects with that of the leaves themselves.

Stipules which serve for protection may again be divided into those with and those without mechanical strengthenings. The palisade-tissue of ordinary leaves is in them altogether wanting; stomata are absent or very few in number; other trichomic structures are usually wanting; anthocyan is very frequently present in the cells. Where there is mechanical strengthening, it is of various kinds:—great thickening and cuticularization of the cell-walls, sclerenchymatous hardening, formation of periderm, &c.

When stipules are converted into bud-scales, they are usually abundantly furnished with trichomes, bristles, woolly hairs, or colleters, which serve to reduce transpiration; the tissue itself may also be modified in various ways, as in protecting stipules. Examples of stipules transformed into ochreæ are furnished by the *Platanaceæ* and *Polygonaceæ*. Structurally they may belong to the class of protecting stipules either with or without mechanical strengthening.

**Foliar Sheath of the Salicorniæ.‡**—M. P. A. Dangeard points out that it is well known that in *Salicornia* the foliar bundles, when traversing the cortex more or less obliquely, give out descending branches, which ramify and anastomose in a rosette in the interior of the cortical parenchyma. The author has studied various types in this family, and gives the following as his conclusions:—That in the Salicorniæ (*Arthrocnemum*, *Salicornia*, *Halostachys*, *Halocnemum*) there is a foliar sheath with palisade-tissue. This sheath is altogether distinct from the cortex in the internodes (*Arthrocnemum fruticosum*), but is sometimes confounded with the cortex in the lower part of the internodes; it incloses a large number of fibrovascular bundles, which proceed from two lateral and symmetrical foliar bundles. The large spiral cells which are met with in *Salicornia peruviana*, *S. virginica*, *Arthrocnemum fruticosum*, and *A. ? ambiguum*, belong to this foliar sheath. The formation of such a sheath ought to be attributed to a decurrence of the edges of the limb, a point which may be easily seen in *Kalidium foliatum*, which has the leaves alternate.

\* Bull. Soc. Bot. Lyon, 1887. See Morot's Journ. Bot., ii. (1883), Rev. Bibl., p. 1.

† Flora, lxxi. (1888) pp. 97-107, 113-128 (1 pl.).

‡ Bull. Soc. Bot. France, xxxv. (1888) pp. 157-60.

**Embryo-sac of Rosaceæ.\***—M. F. Went states that the study of the embryo-sac of the Rosaceæ is interesting, as it leads one to the opinion that either the Rosaceæ and Saxifragaceæ have a common origin, or that the Rosaceæ have descended from the Saxifragaceæ. The chief difference between these two families is the fact that the Saxifragaceæ possess endosperm; but if one examines the Spiræceæ, certain rudimentary traces of endosperm will be found when the seeds are ripe. The Spiræceæ then form the point of transition between Saxifragaceæ and Rosaceæ. The author then, beginning with *Prunus*, describes the form of the embryo-sac in various members of the Rosaceæ, especially pointing out to what extent endosperm is present.

**Petiole of Dicotyledons.†**—M. L. Petit describes the structure of the petiole in various Dicotyledonous families, and gives a table showing the principal differential characters of this organ. The author, in his conclusions, states that the study of the course of the fibrovascular bundles in petioles has been very much neglected. It is useful, however, because of the fact that it is possible to group the numerous objects which are studied under a small number of types. The general law on the disposition of the fibrovascular bundles is, that in herbaceous plants they are usually isolated, while in woody plants they are in close proximity to one another. The author insists on the importance of the petiole for purposes of classification.

**Development of Flowers in the Bud.‡**—M. Louis Mangin states that organs generally present two phases of growth. In the first phase the organ acquires a certain structure, the dimensions of which are very restricted; but in the second phase, an energetic intercalary growth takes place, and the organ arrives at the adult state without sensibly modifying its structure. In this paper, the author records a series of observations on the development of flowers. The fruit trees were first studied on account of their earliness of flowering, and of the ease with which flower-buds can be distinguished from leaf-buds.

If a longitudinal section of a flower-bud of the cherry, taken about the 23rd of June, be examined, the growing point will be found to be protected by four or five layers of scales. A month later the growing point will be found enlarged; the apex, however, now ceases to grow, but round the apex a certain number of cellular papillæ are formed, each of which represents a flower. On the edges of the hollow papillæ five protuberances will be found; these represent the calyx, the hollow portion of the papillæ forming the floral receptacle. About the 16th of August, the base of the calycine protuberances will be found to have enlarged so as to form a tube; on the internal face of this tube, at the base of the indentations separating the calyx-teeth, appear the emergences which represent the petals. Finally, at the base of the receptacle, which has been up to the present time empty, arises the protuberance which is to form the carpel.

The author then traces the growth of the ovules, formation of the pollen, and origin of the bundles, and concludes by comparing the development of the flowers of other members of the Amygdalacæ with the cherry.

\* Ann. Sci. Nat. (Bot.), vi. 1887 pp. 331-41 (1 pl.).

† Ibid., pp. 342-54.

‡ Morot's Journ. Bot., ii. (1888) pp. 1-7, 20-30 (22 figs.).

**Morphology of the Flowers of *Canna*.**\*—Herr K. Schumann discusses several very difficult points in the structure of the flower of *Canna*. The usual view of the inflorescence, that it is a 2-flowered cyme, in which the second flower is not antidromous, but homodromous, he cannot altogether accept, believing rather that it presents an intermediate form between the two chief groups of inflorescences. He also contests the theory of Eichler, that in the formation of the style only one out of the three carpids of which the flower is composed has been concerned.

**Diagram of the Flower of *Cruciferae*.**†—From an examination of abnormal flowers of *Capsella bursa-pastoris*, which displayed phyllody of the flowers and strong branching of the whole plant, Dr. R. Chodat confirms Dr. J. Müller's view that the flower is diplostemonous, and tetramerous throughout. He would construct the diagram thus:—A median bract, usually suppressed; 2 lateral bracts usually suppressed; 4 sepals in an orthogonal whorl; 4 petals in a diagonal whorl; 8 stamens in two alternate whorls of 4, the outer whorl in orthogonal position, of which the two median stamens are usually doubled; the inner whorl in diagonal position, usually suppressed; 4 carpids in orthogonal position, of which the two median ones are usually suppressed.

**Ovules of Grasses.**‡—Besides the ordinary position of the ovules in grasses, ascending and subbasilar, M. H. Baillon describes two abnormal positions; a directly opposite pendent position in *Lygeum*, and an intermediate position, occasional in *Hierochloa borealis*, where the ovule is attached to a point in the ovary about half-way between the base and the apex, and the hilum is situated about half-way along the posterior margin of the ovule, the chalazal and micropylar extremities of the ovule being at about an equal distance from the point of attachment.

**Replum in *Cruciferae*.**§—Prof. I. B. Balfour states that the term replum is used either for the framework of the fruit left after the fall of the valves, across which the septum stretches, or, in most British text-books, for the septum itself. The word was introduced by Brassai; and although he does not specially mention the septum, it is clear from the whole context that he introduced the term for the framework across which the septum stretches, and not for the septum. The use of the word in most of our text-books in Britain is therefore wrong.

**Fruit of *Solanaceae*.**||—M. A. G. Garcin describes the fruit of various members of the natural order *Solanaceae*. The tissues consist of four layers of cells; the innermost but one gives rise to the bundles. The septa are either numerous, as in *Solanum robustum*, or few, as in *Petunia*; but the most important fact is that in certain fruits the definite number of cells has been entirely formed before the ovules are fertilized, that is to say, that in order for the ovary to become transformed into fruit, it has only to increase the dimensions and not the number of the cells. In others, on the contrary, after the ovules are fertilized, further cells are formed. To the first type belong the dry fruits, and, what is a curious

\* Ber. Deutsch. Bot. Gesell., vi. (1888) pp. 55-66.

† Flora, lxxi. (1888) pp. 145-9.

‡ Bull. Mens. Soc. Linn. Paris, 1887. See Morot's Journ. Bot., ii. (1888) Rev. Bibl., p. 33.

§ Annu. of Bot., i. (1888) pp. 367-8.

|| Morot's Journ. Bot., ii. (1888) pp. 108-15 (5 figs.).

fact, certain berries, such as those of *Atropa Belladonna*; but a greater number of the fleshy Solanaceous fruits belong to the second type.

**Motion of rotating Winged Fruits and Seeds.\***—Herr H. Dingler finds that in the path of winged fruits and seeds in falling to the ground when there is a current of air, there is a double motion—a movement of rotation of the body round its own axis, and a helicoid movement in the opposite direction. He explains both these movements on the principle of the motion of a top spun between the fingers.

### β. Physiology.†

#### (1) Reproduction and Germination.

**Pollination and Distribution of the Sexual Organs.‡**—Herr A. Schulz publishes the results of his observations on these points on a very large number of species. The following are some of the more general results at which he has arrived. —

In the Silenæ there is a very strong tendency to unisexuality and dioecism; the female are usually smaller than the male, and these again than the hermaphrodite flowers. Among the latter proterandry is nearly universal. The Alsineæ produce, in addition to the ordinary hermaphrodite, smaller female, but no male flowers; the hermaphrodite flowers are often proterandrous, and usually can be fertilized only by external assistance. Almost all Umbelliferæ have both hermaphrodite and male flowers, either in the same umbel or not; in the former case the marginal flowers of the umbel are usually hermaphrodite, the inner flowers male; but some genera have a central hermaphrodite flower. The hermaphrodite flowers are in most cases so strongly proterandrous that self-pollination is impossible, the stigmas often not arriving at maturity until the stamens and even the petals have disappeared. Almost all Labiatae have female in addition to the hermaphrodite flowers, and they are usually much smaller; the two kinds may occur on the same or on different individuals, and in the former case in the same or in different inflorescences. The hermaphrodite flowers are almost always strongly proterandrous.

**Effect of Cross-fertilization on Inconspicuous Flowers.§**—Miss Anna Bateson gives the details of some experiments showing the effect of cross-fertilization on inconspicuous flowers. The plants experimented on were *Senecio vulgaris*, *Capsella bursa-pastoris*, and *Stellaria media*. In the case of *Senecio vulgaris* the crossed plants showed an advantage in fecundity over the self-fertilized, the average number of seeds per capitulum of the cross-fertilized being to the average number per capitulum of the self-fertilized as 100 to 73. With *Capsella bursa-pastoris* the relation in the case of crossed to self-fertilized plants was as 100 to 96, and with *Stellaria media* as 100 to 95; thus it appears that inconspicuous flowers do benefit by a cross, though apparently in a less degree than those adapted for self-fertilization.

\* Ber. Deutsch. Bot. Gesell., v. (1887) pp. 430-4.

† This subdivision contains (1) Reproduction and Germination; (2) Nutrition and Growth (including Movements of Fluids); (3) Irritability; and (4) Chemical Changes (including Respiration and Fermentation).

‡ Uhlworm u. Hänlein's Biblioth. Bot., Heft 10, 104 pp. and 1 pl., Cassel, 1888.

§ Ann. of Bot., i. (1888) pp. 255-61.

**Germination of *Anemone apennina*.**\*—M. E. de Janczewski points out several singular features in the germination of this species, which produces exceedingly few mature seeds. In the form of the achene and other points it belongs to the section of the genus *Sylviae* (*A. ranunculoides*, *trifolia*, *nemorosa*, &c.) At an early period the young seedling consists of a primary root and of a green deeply bilobed leaf in direct continuation of the root, without any hypocotyl or buds, or any appearance of cotyledons. When about two months old, there appears on the root, which has already branched, a small tubercle situated a little below the junction of the root with the petiole, belonging evidently to the root itself, and composed of parenchymatous tissue loaded with starch. On the upper side of this tubercle is a bud, from which proceed the secondary axes, i. e. all the remaining leaves and the flowers, the primary leaf soon perishing.

**Germination of *Oxalis rubella*.**†—Herr F. Hildebrand describes the peculiar phenomena presented by the germination of this species and others nearly allied to it. The base of the cotyledons lengthens into a sheath inclosing a hollow space within which the base of the single leaf grows downwards. This prolongation of the leaf-stalk becomes compressed by its further growth into a corkscrew-like structure, bearing the apical bud, within the sheath above described. About two or three months after the commencement of germination, the root ceases to grow in length, and swells out in its lower part into a fusiform swelling, which serves as a receptacle for water. The upper part of the root is forced down within the cotyledonary sheath by the continued growth downwards of the base of the leaf-stalk until it reaches this water-receptacle, where the first bulb is formed.

**Germination of the *Bicuiba*.**‡—Herr F. Müller describes the process of the germination of the seeds of *Myristica Bicuhya* Sch., nearly related to the nutmeg. The "ruminated endosperm" characteristic of these plants he considers may be advantageous to the seedling in forcing the growing cotyledons of the very small embryo to a large development of surface by folding and wrinkling.

**Germination of the Tuber of the Jerusalem Artichoke.**§—Mr. J. R. Green summarizes the results of his investigation into the germination of the artichoke tuber (*Helianthus tuberosus*) as follows:—

(1) The inulin stored in the tuber is made available for the use of the plant by ferment-action. (2) This ferment is not diastase, but a special body working on inulin. The inulin-ferment is not able to act upon starch; saliva, which is so energetic with the latter, has little or no power to convert inulin. (3) Its action is to produce from inulin a sugar and an intermediate or collateral product. (4) The latter differs from inulin in its solubility in water and alcohol, its crystalline form, and its power of dialysis. (5) The ferment does not exist as such prior to the commencement of germination, but is present in the resting tuber in the form of a zymogen. (6) Its activity is only manifested in a neutral or very faintly acid medium, and it is destroyed by prolonged contact with acids or alkalis.

\* Comptes Rendus, cvi. (1888) pp. 1544-6.

† Bot. Ztg., xlv. (1888) pp. 193-201 (1 pl.).

‡ Ber. Deutsch. Bot. Gesell., v. (1887) pp. 468-72 (1 pl.).

§ Ann. of Bot., i. (1888) pp. 223-36.

## (2) Nutrition and Growth (including Movements of Fluids).

**Influence of Light on the Growth of Leaves.\***—Sig. G. Arcangeli discusses this subject from a mathematical point of view. He is of opinion that the statement that the size attained by leaves is proportional to the intensity of the light to which they have been subjected is too absolute. While some plants are heliophilous, i. e. are dependent on light for the full development of their foliage, others are sciaphilous, or thrive best, and their leaves assume a full dark-green colour, only when the light is not too intense. This he found to be especially the case with *Euryale ferox* and *Camellia japonica*. It has been shown by Wiesner that in many plants at least the direct rays of the sun act injuriously on the chlorophyll, and hence on the power of assimilation; and the development of the palisade-tissue, the increase in the number of rows of cells of which it is composed, and their elongation in the direction of the incident rays, not merely facilitate the transport of the assimilative substances, but also offer a means for the chloroplasts and the protoplasm to withdraw from the too intense radiation which would act injuriously upon them. The plaiting of the leaves of *Euryale* and of other plants has a similar purpose.

**Supply of Food Constituents at Different Periods of the Growth of Plants.†**—Herr G. Liebscher advances a new theory as a basis for the science of manuring. Each day the root should supply a certain amount of food to the plant; this amount varies more or less at different stages of growth, and further, these variations differ in case of different plants; thus, one species requires a fairly uniform daily supply throughout its period of growth, whilst another requires much more at one stage than at another. Thus, for a plant requiring a uniform daily supply, a slowly decomposing and lasting manure is appropriate, whilst an easily soluble one should be given to a plant whose demand is large during a short period.

## (3) Irritability.

**Power of Contractility exhibited by the Protoplasm of certain Cells.‡**—Mr. W. Gardiner gives the results of experiments made on the power of contractility exhibited by the protoplasm of certain plant-cells. In *Mesocarpus*, we have a cell which reacts in a most powerful manner to the stimulus of temperature, of light, of electricity, and of poisons, and this reaction, which may be watched under the Microscope, is attended by a diminution in size. In the author's opinion, there is in every cell a sufficient quantity of osmotically active substance to insure turgidity, but the increase or decrease of turgidity depends essentially on the contraction or relaxation of the parietal utricle. All the experiments tend to show that it is the ectoplasm which mainly determines the state of turgidity of the cells. The power of contractility which the author has established for the irritable cells of *Drosera* and *Mimosa*, and for the less specialized cells of *Mesocarpus*, is a property which is possessed in a greater or less degree by all the actively living cells which constitute the tissues of plants.

\* Nuov. Giorn. Bot. Ital., xx. (1888) pp. 331-41. Cf. this Journal, *ante*, p. 84.

† Bied. Centr., 1887, pp. 658-60. See Journ. Chem. Soc. Lond., 1888, Abstr., p. 382.

‡ Ann. of Bot., i. (1888) pp. 362-7.

**Movements of Irritation of Multicellular Organs.\***—Herr J. Wortmann confirms by fresh observations his previous conclusion that the curvatures of irritation of invested cells, or of masses of cells, which take place during growth, depend on movements of the protoplasm. In the organ observed, the root of *Phaseolus multiflorus*, he finds, whenever there is geotropic irritation, a more or less abundant transference both of starch and of protoplasm to the parts where a strong formation of cellulose takes place. This fact furnishes a strong argument in favour of De Vries's view † that the transport of formative materials in the plant does not take place by osmosis, but is effected through the movements of the protoplasm-body.

**Irritability of Growing Parts of Plants.‡**—Prof. E. Godlewski supports the views of Wortmann § with regard to the nature of this phenomenon. He classifies the various phenomena belonging to this category under the following heads, viz. :—

(1) Phenomena which must be regarded as resulting from the positive geotropism of the specific protoplasm of the root. Under this head come the geotropic downward curvatures of roots removed from their normal position, and the facts that when shoots are hung horizontally in moist air, adventitious roots are formed only on the under side; that when a cut shoot is hung vertically in natural position, adventitious roots are formed only at the basiscopic end; that in general roots form more readily in the basiscopic than in the acroscopic portion of a shoot; and that in the bulbils of *Marchantia* the rhizoids grow only on the under surface.

(2) Phenomena which result from the negative heliotropism of the specific protoplasm of the root:—The negatively heliotropic curvature of many roots and root-hairs when more strongly illuminated on one side; the retarding effect of light on the new formation and development of the rudiments of roots; the formation of adventitious roots exclusively on one side of an organ illuminated on one side only, such as ivy-shoots, prothallia of ferns, &c.

(3) Phenomena resulting from the positive hydrotropism of the specific protoplasm of the root:—The curvature of roots in the direction of the greater moisture; the favourable influence of moisture on the fresh formation and development of the rudiments of roots; the fact that the roots of plants growing on a block of turf rotating on a clinostat become closely attached to, or even grow into the turf.

(4) Phenomena resulting from the negative geotropism of the specific protoplasm of the shoot:—The geotropic curving upwards of growing shoots removed from their normal position; and the facts that on a horizontal shoot, whether cut or still attached to the parent plant and placed in moist air, the buds which face upwards grow much more rapidly than those that face downwards, the latter often remaining quite dormant; that, when a plant is reversed, new shoots are formed on its oldest part, where they would not be formed if the plant were in its natural position; and that when cut pieces of a shoot or root are placed in moist air, regeneration of the buds takes place at the acroscopic end of the shoot, and at the basiscopic end of the root.

\* Ber. Deutsch. Bot. Gesell., v. (1887) pp. 458-68 (2 figs.). Cf. this Journal *ante*, p. 259.

† See this Journal, 1885, p. 665.

‡ Bot. Centralbl., xxxiv. (1888) pp. 82-5, 143-6, 181-4, 211-3.

§ See this Journal, *ante*, p. 259.

(5) Phenomena resulting from the positive heliotropism of the specific protoplasm of the shoot:—The positively heliotropic curvatures of growing shoots; the fact that seedlings, when growing in the light on a block of turf rotating in a clinostat, place their hypocotyledonary organs at right-angles to the surface of the block.

(6) Phenomena resulting from the negative hydrotropism of the specific protoplasm of the shoot:—The negative hydrotropic curvatures at the conidiophore of *Phycomyces nitens*.

(7) Phenomena which must be regarded as a consequence of a combination of these various causes.

**Sensitive Labellum of *Masdevallia muscosa*.**\*—Mr. F. W. Oliver states that up to the present time only two genuine cases of motile labella have been recorded in Orchids: *Megaclinium*, in which the movement is spontaneous, and *Pterostylis* where it is called forth by an external stimulus. The object of the present paper is to give an account of the mechanism of movement of a new case, *Masdevallia muscosa* Rehb. f. This plant produces a number of flowers borne singly on erect scapes some 15 cm. long. The labellum is roughly triangular and articulated by a delicate hinge to the foot. The movement is displayed as a sudden and rapid folding up of the labellum on its band-like neck, so that the broad distal part of the blade is approximated to the top of the column. This movement is called forth by the gentlest touch of a hair or insect's foot on the median crest of the blade. Within a second of stimulating the crest, the blade is moved upwards through an angle of some  $10^\circ$ , then for a brief space, which is only just appreciable, and amounts to a small fraction of a second, a slight hesitation or slowing, as it were, is noticeable, and finally, the upward movement is continued through a further angle of  $70^\circ$  or  $80^\circ$  with great rapidity. The whole process barely occupies two seconds. This manifestation of movement in the labellum seems to be simply one of the numerous ways chanced on by orchids in promoting cross-fertilization by the agency of insects.

#### (4) Chemical Changes (including Respiration and Fermentation).

**Formation of Nitric Acid in Plants.**†—Herr B. Frank contests the ordinary view that the conversion of nitrates into organic nitrogenous substances takes place exclusively in the leaves. He finds, on the contrary, as the result of direct experiments, that in those which he terms "nitric acid plants" much more nitric acid is absorbed during the period of growth than is required at the time for the formation of new organs, and that the excess accumulates in the form of unchanged nitrates in all the organs adapted for the purpose—the parenchyma of the root and stem, the leaf-stalk, and veins—where it is stored until the period of ripening of the fruit. The transformation of the nitrates into nitrogenous substances which serve as food-materials for the plant takes place in all the organs which are penetrated by vascular bundles, even in the root. He further states that the whole of the nitrate contained in vegetable tissues must have been absorbed as such by the root, the plant having no power, whether in the light or in the dark, of converting ammonium salts into nitrates.

As examples of typical "nitric acid plants" Herr Frank names the

\* Ann. of Bot., i. (1888) pp. 237-53 (1 pl.).

† Ber. Deutsch. Bot. Gesell., v. (1887) pp. 472-87.

sunflower, pea, haricot-bean, scarlet-runner, cabbage, maize, wheat, cucumber, and *Trifolium hybridum*; while, on the other hand, the lupin and most woody plants contain but a very small proportion of nitrates.

#### γ. General.

**Volkens' Desert Flora.**\*—In his 'Flora of the Egypto-Arabian Desert' Herr G. Volkens states a number of exceedingly interesting facts respecting the means of protection of desert plants against excessive evaporation, such as the storage of water in tissue especially adapted for the purpose, a dense covering of hairs, unusual length of the root, &c.; and discusses the question whether transpiration is a physiological or a purely physical process.

**Detmer's Laboratory Course of Vegetable Physiology.**†—Prof. W. Detmer publishes a very useful handbook for the use of practical students in vegetable physiology. The methods of manipulation are, in particular, described with great minuteness.

**Isotonic Coefficient of Glycerin.**‡—The isotonic coefficient of glycerin has generally been assumed, in experiments on the plasmolysis of cells, to be about 2, but without being founded on any definite observations. Herr H. de Vries has determined the point experimentally. In the first place he was able to confirm Klebs's statement§ of the permeability of the protoplasm for glycerin, not only in the cells of *Zygnema*, but also in *Spirogyra*, and in those of the violet epidermis of the under side of the leaf in *Tradescantia*. But the permeability of protoplasm varies in different plants, in different cells of the same plant, and probably also in the same cells at different periods and under different external conditions. As the result of a series of experiments de Vries found the isotonic concentration of potassium nitrate, as compared with that of glycerin, to be, on the average, 0.592, and the isotonic coefficient of glycerin to be 1.78. The following are the coefficients for other substances:—cane-sugar, 1.88; invert-sugar, 1.88; malic acid, 1.98; citric acid, 2.02; tartaric acid, 2.02.

## B. CRYPTOGAMIA.

### Cryptogamia Vascularia.

**Oophyte of Trichomanes.**||—Prof. F. O. Bower describes certain normal and abnormal developments of the oophyte of *Trichomanes pyxidiferum* and *alatum*.

In the former species the spores germinate freely while still within the indusium, or even in the sporangium, developing a much-branched filamentous protonema-like prothallus, not unlike a *Vaucheria* to the naked eye, resembling the protonema of a moss, but coarser; the filaments are partitioned by septa into somewhat barrel-shaped cells. This prothallus is frequently an aposporous growth, derived from imperfect sporangia arrested in their growth, or even from cells of the columella. The antheridia are produced laterally on the prothallus, either singly or

\* Volkens, G., 'Die Flora d. ägyptisch-arabischen Wüste,' 156 pp. and 18 pls. Berlin, 1887. See *Flora*, lxxi. (1888) p. 25.

† Detmer, Dr. W., 'Das Pflanzenphysiologische Prakticum,' Jena, 1888.

‡ Bot. Ztg., xlv. (1888) pp. 229-35, 245-53.

§ See this *Journal*, 1887, p. 440. || *Ann. of Bot.* i. (1888) pp. 269-305 (3 pls.).

in pairs, and are shortly-stalked spherical bodies presenting nothing very striking in their structure. The archegonia are borne on *archegoniophores* or massive outgrowths of the prothallium, each archegoniophore bearing either a single archegonium or a number. The archegoniophore is usually a multicellular structure, and the venters of the archegonia are imbedded in its tissue. The species is probably dioecious. In old fronds there is an additional mode of propagation by direct budding, resulting in the formation of new sporophytes.

In *T. alatum* Prof. Bower supplements his previous description of aposporous and apogamous developments.\* Although normal sporangia and spores are in some cases produced, the greater number of the prothalli observed were formed, not by germination of spores, but by peculiar aposporous growths which arise in remarkable profusion from such old fronds as have fallen to the ground, or even from the tips of pinnae of fronds which still retain their normal position. The prothalli differ from those of *T. pyxidiferum* in being frequently not protonemal, but flattened structures. They may arise from the surface of the frond or from the sporangium, with or without the intervention of protonemal filaments. On their apices are very frequently produced in great numbers the remarkable spindle-shaped gemmæ borne on sterigmata. The protonemal filaments and the prothalloid growths may pass insensibly one into another. From the filaments are produced either rhizoids or protonemal branches. The mature gemmæ are composed of from five to seven cells; they germinate only with extreme slowness. The antheridia are produced on the protonema, but have never been seen to produce antherozoids; and no archegonia have ever been seen on cultures of this species. The author believes that this species is never reproduced sexually; apogamous budding is common on the protonema.

As regards the bearing of these facts on the phylogenesis of Ferns, Prof. Bower thinks there can be no doubt that the Hymenophyllaceæ must be regarded as the lowest family of Ferns, and that the protonema of *Trichomanes* corresponds to the protonema of a Moss. The oöphyte is probably the more ancient of the two generations in the Filicineæ, but is adapted only to conditions of great and uniform moisture. For the dissemination of the spores of the sporophyte dryness is in most cases essential; and when the fern grows in very moist situations, as is the case with the Hymenophyllaceæ, we have the dissemination of the spores in abeyance, and a general reversion to aposporous reproduction.

**Development of *Onclea Struthiopteris* Hoffm. (*Struthiopteris germanica* Willd.).**†—Dr. D. H. Campbell publishes a very careful and detailed account of the development of the "ostrich fern." The spores have, when mature, three distinct coats, a brown exospore, furnished with ridges and folds, and two inner coats. The prothallium is distinctly dioecious, the female prothallia being usually larger than the male. By contracting and staining, the continuity of protoplasm from cell to cell of the prothallium can be clearly demonstrated. The antheridia and archegonia are distinctly trichomic in their origin, the latter are much more limited in their distribution than the former. The ventral canal-cell of Janczewski does not appear to exist in the archegonium. The actual

\* See this Journal, *ante*, p. 262.

† Mem. Bost. Soc. Nat. Hist., iv. (1887) pp. 17-52 (4 pls.).

entrance of an antherozoid into the central cell was observed. At an early period in the development of the embryo it consists of eight primary cells, each of which has the form characteristic of the apical cell of the mature stem and root.

The vascular bundles of the stem contain no true vessels, but tracheids, which are chiefly scalariform, though there are some spiral and reticulate ones, and sieve-tubes. Each leaf originates from a single segment of the apical cell of the stem. The leaf-stalk develops at first much more rapidly than the lamina, which remains very small proportionately until the latter part of the summer previous to its unfolding, after which its development is remarkably rapid. As in some other ferns, the arrangement of the leaves in the mature plant is in a  $5/13$  spiral phyllotaxis, although they are so crowded that it is difficult to make this out. The growing point of the stem is completely concealed by the young leaves; the epidermis of the stem is very feebly developed.

The sori are formed in connection with the veins. The division of the nucleus in the formation of the spores was very clearly followed out; the formation of the nuclear spindle was distinctly seen, but no satisfactory view of the nuclear disc could be obtained. The cells of the annulus soon project above the other cells of the sporangium, and their division-walls become thicker. The cells of the annulus on one side of the sporangium are rather more elongated than the others; and four, or sometimes only three of these near the base of the capsule form the "stomium," at which place the capsule opens.

**Branching of the Frond of Ferns.\***—According to Herr W. Möhring, sympodial branching in the frond of ferns never takes place in any of the species examined by him. In the youngest state of the frond he finds a two-edged apical cell, which soon produces a periclinal, and then cuts off segments towards the upper and under side of the leaf. This cell divides again by an anticlinal into two cells, the true apical cells of the frond. Beneath the apex the segments are produced in acropetal succession. The course of the veins is dichotomous, one of the two branches having greater energy of growth than the other; but the branching of the leaf remains monopodial. Its growth in length is determined only by the apical cell, its growth in breadth by the marginal cells.

**Leaves of Polypodiaceæ.†**—Herr W. Benze describes the adaptations for different degrees of moisture in various Polypodiaceæ. A typical assimilating system is wanting in *Adiantum*; palisade-cells occur in species of *Acrostichum*, in *Platyserium alicorne*, and *Polypodium Lingua*; branching palisade-cells in *Asplenium falcatum*, *Aspidium Sieboldi*, *Blechnum*, *Dicksonia*, and *Doodia*. Stomata are found only on the under side of the leaf, and depressed in the tissue only in *Polypodium Lingua* and *Platyserium alicorne*. The mechanical tissue is usually composed of bast-cells, less often of collenchymatous cells.

**Aspidol from Aspidium Filix-mas.‡**—Signor G. Dacomo has obtained from the root of the male fern a compound which has received

\* Möhring, W., 'Ueb. d. Verzweigung d. Farnwedel,' 33 pp., Berlin, 1887. See Bot. Centralbl., xxxiv. (1888) p. 7.

† Benze, W., 'Ueb. d. Anatomie der Blattorgane einiger Polypodiaceen,' 47 pp., Berlin, 1887.

‡ Ann. Chim. Farm., lxxxviii. pp. 69–90. See Journ. Chem. Soc. Lond., 1888, Abstr., p. 521.

the name of *aspidol*; it has the composition  $C_{20}H_{34}O$ , and is insoluble in alkalis, but easily soluble in ether, benzene, chloroform, light petroleum, and hot alcohol.

*Selaginella lepidophylla*.\*—M. Leclerc du Sablon describes the curious property of revivification possessed by *Selaginella lepidophylla*. When the root withers, each branch curls up, and the plant appears more or less in the form of a ball. In this state it is able to remain for a long time; and then, when the water necessary for its growth is supplied, the branches unroll, the green color which had almost disappeared returns, and the branches and roots recommence to grow. The structure of the plant is such that when dehydration occurs, the cells on one side of a branch are thicker than those on the other, thus they contract unequally and cause the branch to curl up.

Solms-Laubach's Introduction to Fossil Botany.†—This valuable work is devoted chiefly to the remains of Vascular Cryptogams, no reference being made to Angiosperms, and a small portion only of the space being devoted to Thallophytes, Muscineæ, and Gymnosperms. Besides the organisms of doubtful position, he classifies the fossil Vascular Cryptogams under the following heads, viz.:—Ferns, Equisetaceæ, Hydropterideæ, Lycopodites and allied forms, Lepidodendreae, Sigillarieæ, Stigmaria, Calamariæ, and Sphenophylleæ. The Leiodermariæ are regarded as belonging to the Sigillarieæ rather than to Gymnosperms. The Calamariæ are treated as belonging to a different section to the true Equisetaceæ, and as having been furnished with both macrospores and microspores.

#### Muscineæ.

Peristome of Mosses.‡—Continuing his observations on this organ, M. Philibert now especially deals with the structure of the internal peristome and its variations. The internal peristome of the Orthotricheæ is not very dissimilar from that of *Neckera*, *Webera acuminata*, *Cylindrothecium*, and the other Hypnobryaceæ, where the basilar membrane is very short. The primitive rosette is always composed, on the dorsal surface, of sixteen rows of rectangles opposite to the ventral plates of the teeth, and on the ventral surface, of less regular trapezes forming fewer rows. This structure of the internal peristome is not essentially different from that of the Bryaceæ. In the genus *Cinclidium* the internal peristome presents a somewhat singular aspect. It has the form of a cylinder closed above by a hemispherical dome. The lower half has the same appearance, the same colour, and the same structure as in the genus *Mnium*. The only difference between the structure of the internal peristome in the Cinclidiæ and the genus *Mnium* is that in the former the thickening extends all over the surface of the peristomal cylinder. In the Fontinalaceæ the internal peristome has the form of an elongated cone, composed of sixteen straight, vertical filiform columns, which are connected by numerous equidistant horizontal branches. *Cinclidium subrotundum* forms a connecting link between the structure as found in the Cinclidiæ and that of the Fontinalaceæ.

\* Bull. Soc. Bot. France, xxxv. (1888) pp. 109-12.

† Solms-Laubach, H., Graf zu, 'Einleitung in die Palæophytologie,' 416 pp. and 49 figs., Leipzig, 1887.

‡ Rev. Bryol., xv. (1888) pp. 24-8, 37-44. Cf. this Journal, ante, p. 461.

**German Sphagnaceæ.\***—Herr E. Russow contests the view of Röhl † that the species of *Sphagnum* cannot be distinguished by any constant characters, but pass insensibly one into another. He finds, on the contrary, the specific characters as well marked as in any other group of plants. Herr Russow includes in the section *Eusphagnum* twenty-two European species, which he classifies as follows:—(1) ACUTIFOLIA (*S. fimbriatum* Wils., *Girgensohnii* Russ., *Russowii* Warnst., *Warnstorffii* Russ., *tenellum* Kling., *fuscum* Kling., *quinquefarium* Warnst., *subnitens* R. & W., *acutifolium* Ehrh. ex parte); (2) PAPILLOSA (*squamosum* Pers., *teres* Angst., *Wulfianum* Girg.); (3) CUSPIDATA (*Lindbergii* Schpr., *riparium* Angst., *cuspidatum* Ehrh., *molluscum* Bruch.); (4) SUBSECUNDA (*cavifolium* Warnst.); (5) TRUNCOATA (*molle* Sulliv., *rigidum* Schpr., *Angstrœmii* Hartm.); (6) CYMBIFOLIA (*palustre* L., *Austini* Sulliv.). Of these, *S. Warnstorffii* is new.

#### Lichenes.

**Cladonia.‡**—In his monograph of this genus of lichens, Herr E. Wainio describes four species of the subgenus *Cladina*, two of *Pycnothelia*, and eighty-one of *Cenomyce*. In the diagnosis of the species he makes use of characters drawn from the form and size of the spermogonia, from a red pigment, chrysophanic acid, which he found in several species with brown and light apothecia, and from the presence or absence of certain layers in the podetia. In each species the gonidia of the podetia and of the thallus are described.

The author takes the opportunity of correcting Krabbe's description of *C. papillaria*,§ who states that only pseudopodetia occur on it, whereas it possesses true podetia.

**Sydow's Lichens of Germany.||**—Herr P. Sydow publishes a monograph of the Lichens of Germany, amounting to 1065 species. The classification adopted is founded on that of Massalongo and Körber. After an introduction on the morphological and anatomical characters of the group, follow directions for the collection and preparation of lichens, a guide to the literature, a *clavis* for the determination of the families, and a description of each species.

#### Algæ.

**Apical Cell of Fucus.¶**—Mr. W. M. Woodworth has made a careful study of the structure of the growing point in *Fucus*, and is unable to confirm the statements of Reinke and Rostafinski as to the existence of a group of initial cells. The species chiefly examined is *F. furcatus* of the New England coast.

The author finds the apex of the frond to be here frequently occupied by a slit-like depression of considerable depth. Sections in different directions through the growing point show that at the base of this terminal depression there is always one cell considerably larger than all the rest; on either side of this apical cell is a series of cells that become

\* Russow, E., 'Ber. üb. d. . . . einheimischen Torfmoosen,' 1887, 23 pp. See Bot. Centralbl., xxxiv. (1888) p. 103.

† See this Journal, 1886, p. 108.

‡ Wainio, E., 'Monogr. Cladoniarum univ. Pars prima,' 509 pp., Helsingfors, 1887.

§ See this Journal, 1882, p. 388.

|| Sydow, P., 'Die Flechten Deutschlands,' 334 pp. and numerous figs., Berlin, 1887.

¶ Ann. of Bot., i. (1888) pp. 203-11 (1 pl.).

smaller as the distance from the central cell increases; and these are continuous with the epidermal cells. At the base of these larger cells are smaller ones of irregular shape, from which the hyphæ of the stem originate. The larger central cell is undoubtedly the initial cell of all the rest; it is a four-sided wedge-shaped cell, the smaller and upper end being rounded and the base truncated; its longer diameter is at right angles to the broad surface of the frond.

The same general results were obtained in *F. vesiculosus* and *F. filiformis*.

The preparations were made by preserving the fresh material in alcohol of about 70 per cent., and imbedding in paraffin, after staining with various anilin dyes; sections were then made in ribbons on a Jung microtome, and mounted in balsam.

**Phycocerythrin.\***—Herr F. Schütt proposes the term rhodophyll for the compound pigment of the red algæ, limiting the use of phycocerythrin to the portion soluble in water, while the portion soluble in alcohol he calls Floridæe-green. Corresponding to the terms chlorophyll and rhodophyll, we shall then have phæophyll for the chromophyll of the Phæophyceæ, cyanophyll for that of the Cyanophyceæ, melinophyll for that of the Diatomaceæ, and pyrrophyll for that of the Peridineæ. In the same manner, the portion soluble in alcohol is composed of chlorophyllin and of the various forms of xanthophyllin found in the different groups, viz. phycoxanthin, diatomin, and peridiniu; while the pigments soluble in water may be termed phycocerythrin, phycophæin, and phycopyrrin.

The absorption-spectrum of a solution of phycocerythrin is described in the cases of extracts of *Ceramium rubrum* and *Dumontia filiformis*.

**Procaryp and Cystocaryp of Gracilaria.†**—Mr. T. Johnson finds that the position of the hitherto undetected procaryp in *Gracilaria confervoides* is indicated by a lateral swelling. The procaryp consists of six or seven cells, distinguished by general arrangement, size, and contents from the surrounding cells of this swelling. From an apical and usually smaller cell of this group arises the trichogyne, which, after a more or less circuitous course within the swelling, reaches the external surface, on which it projects, exposed for contact with the "spermatium." The pericaryp is, in *Gracilaria*, formed before fertilization, and, together with the procaryp and placenta, arises by repeated periclinal division of the two or three outermost cortical layers of cells of the swelling.

The act of impregnation exhibits several remarkable peculiarities. The cells both of the procaryp and of the placenta coalesce with one another by the disappearance of their cell-walls; and the fused cells of the procaryp and of the placenta are placed in communication with one another by protoplasmic protrusions (diverticula), proceeding from the fused cells of the procaryp and passing through their swollen walls. The cells forming the free surface of the placenta now produce radiating rows of basipetally formed spores; while from the fused procarypial cells other diverticula arise, which also form spores at their free ends independently of the placental cells.

The author suggests that the nucleus resulting from the impregnation of the trichogyne by the "spermatium," fuses in turn with the nuclei of

\* Ber. Deutsch. Bot. Gesell., vi. (1888) pp. 36-52 (1 pl.).

† Ann. of Bot., i. (1888) pp. 213-22 (1 pl.).

the combining procarpal cells. This complex nucleus then undergoes repeated division, and the daughter-nuclei pass, one through each of the diverticula, into the placental cells, there to fuse with their nuclei, this union being followed by division. This process occurs throughout the whole placenta, so that in the end each of the placental cells from which the spores are directly formed, has received into its nucleus part of the substance of the nucleus formed by the fusion of the nucleus of the "spermatium" with that of the carpogenous cell.

The procarpal cells of *Gracilaria* are homologous with the auxiliary cells in *Dudresnaya*; but, owing to the concentration of these cells round the procarp, there is no need of the long connecting-tubes of the latter genus, which are replaced by the protoplasmic protrusions or diverticula. Nothing was seen corresponding to the production, in *Dudresnaya*, of several cystocarps from a single procarp.

**Fronde of *Champia parvula*.**\* — Mr. R. P. Bigelow confirms the observations of Debray† on the structure of the frond of this seaweed, and adds also particulars regarding those of *C. salicornioides*, *Lomentaria Baileyana*, and *L. Coulteri*.

**Development of *Hydrurus*.**‡ — Herr G. Lagerheim finds this alga extraordinarily abundant in the neighbourhood of Freiburg-i.-B. in the winter and spring, disappearing in the summer, as it grows only in cold running water. Each individual is inclosed in a slimy gelatinous envelope which differs in consistency at different parts of the thallus, but is quite structureless. The cells are dispersed through this jelly; towards the apex of the branches they are in close contact with one another; but in the older parts of the thallus they are at some distance apart; while at the base, above the point of attachment, they are again crowded. In each cell are one or two parietal chromatophores, coloured brown by phycophæin, accompanied apparently by phycoxanthin. Each chromatophore contains a lenticular pyrenoid, and probably a single nucleus. In the lowest part of the protoplasm are several small vacuoles, some of which can be distinctly seen to pulsate. Each cell is surrounded by a very delicate membrane, possibly of the same substance as the envelope, but containing less water.

It is only the cells of the branches which produce zoospores, each cell in this position giving birth to either two or four. They force their way through the deliquescent cell-membrane and envelope, and, when mature, are of very peculiar form. When mature they are tetrahedral, each angle being prolonged into a slender colourless beak; in one of the angles is a brown chromatophore; and in the centre of the side opposite to the chromatophore a single short cilium, and near it two pulsating vacuoles, but no pigment-spot. The zoospore moves very slowly with its cilium in front. After a time it rounds itself off. They appear to germinate directly without conjugation.

*Hydrurus* probably remains in a dormant state through the summer and autumn. The author has found at this time on stones in streams collections of roundish cells inclosed in jelly, which may be the palmella-condition of the alga. He has observed the formation of resting-spores, which are produced, like the zoospores, in the branches, about  $15\ \mu$  in

\* Proc. Amer. Acad. Arts and Sci., xxiii. pp. 111-20. See Bot. Centralbl., xxxiv. (1888) p. 99.

† See this Journal, 1887, p. 621.

‡ Ber. Deutsch. Bot. Gesell., vi. (1888) pp. 73-85 (5 figs.).

diameter, nearly spherical and inclosed in a firm double membrane. They are also surrounded by a peculiar stalked envelope of colourless gelatin, which forces itself through the gelatinous envelope of the thallus, and finally becomes detached. They are produced on different individuals from the zoospores.

With regard to the systematic position of *Hydrurus*, Lagerheim thinks that it should possibly be placed as a diverging branch at the base of the Phaeophyceæ.

**Development of *Pediastrum*.**\*—Herr E. Askenasy has been able to follow out the history of development of this alga, chiefly in the case of *P. Boryanum*, and has found it correspond closely to that of *Hydrodictyon*. He found this species accompanied by large quantities of a *Polyedrium*, which he calls *P. polymorphum*, with a rather thin cell-wall, and spiny. This is a stage in the development of *Pediastrum Boryanum*. The contents of the *Polyedrium*-cell gradually arrange themselves into a disc, its membrane then bursts by a transverse slit, and the entire contents, still surrounded by the innermost layer of the membrane, escape through the slit and assume a globular or ellipsoidal form, the macrogonidia being now in active "swarming" movement. Finally they arrange themselves in a plane, invest themselves in a thick membrane, and become a *Pediastrum*-disc. These cœnobia may again produce new cœnobia of the same kind, and in either case the process is a very rapid one. The usual number of cells in a cœnobium is sixteen, thirty-two, or sixty-four.

The author believes that a large number of forms hitherto described as distinct species of *Pediastrum* are in reality but stages in the development of other species.

A nucleus can be readily detected in the cells of *Pediastrum*, as also, in young discs, distinct chromatophores.

Herr Askenasy has been able to follow the escape of the macrogonidia from the cells of the cœnobium; they are provided with two very short cilia, which are very difficult to detect. The microgonidia are fusiform in shape, and are provided with two long cilia; they are gametes, and conjugate with one another, but not with those which originate from the same cell. The zygotes soon come to rest, surround themselves with a firm membrane, and increase gradually in size from 4  $\mu$  to 21 or 24  $\mu$ . After a long period of rest they no doubt develop swarm-spores, in the same manner as *Hydrodictyon*, from which polyhedria are developed.

The author regards *Hydrodictyon* and *Pediastrum* as forming together a single family very nearly related to the Volvocinæ.

**Algæ parasitic on the Sloth.**†—M<sup>de</sup>. Weber van Bosse describes algæ, comprising three new species and two new genera, found as a parasitic growth on the hairs of two genera of Tardigrada, *Bradypus* and *Choleopus*. On the side exposed to the light the hairs of these sloths are completely covered, when living in their natural very moist atmosphere, to the extent of possibly 150,000 to 200,000 individuals on a single hair.

One of the species is green, and appears to constitute a new genus of Chroolepidæ. It has two kinds of reproductive organ, large ovoid

\* Ber. Deutsch. Bot. Gesell., vi. (1888) pp. 127-38 (1 pl.).

† Natuurk. Verhand. Holland. Maatsch. Wetensch. (2 pls.), 1887. See Bot. Centralbl., xxxiv. (1888) p. 161.

macrozoospores with four cilia, and small ovoid or angular microspores, on which no cilia were detected. The mode of reproduction could not be followed. The following is the description of the new genus *Trichophilus*:—Fila articulata, irregulariter ramosa, in stratis tenuibus expansa, amœne viridia; fila singula late confluentia, ad apicem plerumque sensim attenuata, reptantia. Ramuli uni- pauci-articulati, appendice radiciformi destiti. Articuli vegetativi cylindracei, diametro æquali vel  $1/2$  latiore longitudini, ad genicula leviter constricti, contento viridi, chromatophoris exiguis, loculo centrali sine colore, granulis minutis circumdato; membrana hyalina, firma, duobus stratis constituta. Cellulæ vegetativæ intumescens in zoosporangiis transmutantur. Propagatio agamica macro-zoosporis et microsporis. Macro-zoosporæ liberæ ovatæ, polo antico hyalino, ciliis quaternis vibrantibus instructæ; contento viridi, oculo rubro non viso. Microspora contenti divisione succedanea repetita ortæ, 32 in quaque cellula, pariete matricali lateraliter ostiolo poriformi aperto liberatæ, macrosporis minores, ovatæ v. angulatæ et ciliis destitutæ. Verisimile statim porro evolventes, nec inter se discedentes in thallum transformantur. Propagatio sexualis adhuc ignota.

The two other parasitic algæ are violet, belonging to the family Chæsiophoneæ, and forming a new genus named *Cyanoderma*, with coccogonia, each of which contains a varying number of gonidia. The following is its diagnosis:—Algæ unicellulares, conidiis et cellularum vegetativarum divisione sese multiplicantes. Cellulæ vegetativæ cum coccogoniis in eodem thallo evolventes, contento homogeneo, colore cœrulescente violaceo, minutæ, in pili substantiam penetrantes. Coccogonia globosa aut subglobosa, membrana crassa circumdata, matura demum ad apicem soluta. Conidia pauca aut numerosissima, et contenti divisione in tres directiones angulis rectis sese secantes orta. Species omnes in aere crescentes.

**Conjugation of Spirogyra.\***—Herr C. E. Overton has followed the course of the process of conjugation in *Spirogyra*, especially in *S. decimina* and *nitida*. He finds the most convenient fixing material to be chromic acid and its compounds, or picric acid, and the preparation was then stained with an alcoholic solution of borax-carmin, treating afterwards with a 0·1–0·5 per cent hydrochloric acid in 70 per cent. alcohol.

In *S. Weberi*, with a diameter of 24–28  $\mu$ , the conjugating processes approached one another with a rapidity of about 3  $\mu$  in the hour. After contact, it takes twenty-four hours for them to become firmly attached to one another, and for the separating wall to become absorbed. The author believes that, during their growth, a substance is exuded from the processes by which the direction of their growth and their ultimate meeting is brought about. The development of the processes does not appear to be always caused by their mutual action on one another, as a cell is sometimes found to put out one of great length, which does not unite with any other cell. In many species the sexual nature of the cells can only be regarded as relative, not absolute, as is shown by the occurrence of lateral conjugation. This frequently takes place with groups of four cells, of which the two central ones are of the same sex.

The passage of the contents of the male cell, which usually takes place at night, is a purely physical process. By the use of the method mentioned above, and examining in xylol or Canada balsam, it is easy to

\* Ber. Deutsch. Bot. Gesell., vi. (1888) pp. 68–72 (1 pl.).

detect the two nuclei in the zygote after conjugation, which afterwards coalesce. The formation of the membrane of the spore probably takes place by apposition.

*Uronema*, a new genus of Chlorozoosporeæ.\*—Herr G. Lagerheim gives the following diagnosis of this new genus of Algæ, which he regards as a connecting link between the Chætophoracæ and the Ulothricacæ:—Fila non ramosa, mucro non involuta, e serie simplicium cellularum formata, basi adnata. Cellula apicalis attenuata. Membrana cellularis tenuis et hyalina, non lamellata. Nuclei cellularum singuli. Chromatophori singuli, parietales, laminiformes, virides, margine inæquali, pyrenoidis binis (rarius singulis) præditi. Megazoospore singulæ, rarius binæ (vel complures?) e contentis cellularum omnium fili non mutatarum ortæ, ovoideæ, ciliis vibratoriiis quaternis et puncto rubro præditæ, per ostiolum magnum poriforme vel cellula parte mediana membranæ gelificata fracta examinantes, germinantes fila nova formantes. Aplanospore contractione contentus cellulæ formate (vel e zoosporis ortæ?).

The species on which the genus is founded, *U. confervicolum*, was found by the author epiphytic on filaments of *Conferva* in ditches near Warberg in Sweden. He thinks it probable that *Stigeoclonium simplicissimum* Reinsch belongs to the same genus.

Wille's Contributions to Algology.†—Prof. N. Wille publishes in German a number of his observations on various classes of Algæ, most of which have appeared before only in Swedish. They comprise:—On the swarm-cells of *Trentepohlia* and their conjugation; ‡ On a new endophytic alga (*Entocladia Wittrockii*); § On cell-division in *Conferva*; || On cell-division in *Edogonium*; ||| On the germination of the swarm-spores of *Edogonium*; ¶ On the resting-cells of *Conferva*; \*\* On the genus *Gongrosira*; †† and on akinetes and aplanospores; ††† as well as the paper on *Chrysopyxis bipes* and *Dinobryon sertularia*. §§ In the paper on *Gongrosira*, Prof. Wille gives this definition of his terms *akinetes* and *aplanospores*:—The former are non-motile reproductive cells produced non-sexually and without rejuvenescence; the latter are non-motile reproductive cells produced non-sexually by rejuvenescence. Akinetes occur in *Trentepohlia*, *Conferva pachyderma*, and *Ulothrix*, as well as in the so-called spores of Nostocacæ and Rivulariacæ; aplanospores in *Conferva stagnorum* and *Wittrockii*. The two kinds of resting-cells pass into one another, and akinetes into ordinary vegetative cells, by insensible gradations.

Hansgirg's Alga-flora of Bohemia. ||||—Prof. A. Hansgirg has now completed the first part of his important 'Prodromus of the Alga-flora of Bohemia,' comprising the Rhodophycæ, Phæophycæ, and Chlorophycæ. The number of species described is 523, each genus being illustrated by one or more woodcuts.

Hansgirg agrees with Rostafinski in including *Hydrurus* and *Chromo-*

\* Malpighia, i. (1887) pp. 517-23 (1 pl.).

† Pringsheim's Jahrb. f. Wiss. Bot., xviii. (1887) pp. 425-518 (4 pls.).

‡ See this Journal, 1879, p. 601. § Ibid., 1880, p. 1023.

|| Ibid., p. 1024.

¶ Ibid., p. 1025.

\*\* Ibid., 1882, p. 836.

†† Ibid., 1884, p. 107.

††† Ibid., p. 272.

§§ Ibid., 1883, p. 863.

|||| Hansgirg, A., 'Prodr. d. Algenflora v. Böhmen,' Theil 1, Heft 2, Prag, 1888. See Bot. Centralbl., xxxiv. (1888) p. 97. Cf. this Journal, 1887, p. 125.

*phyton* under Phæophyceæ, as well as *Syncrypta*, usually placed under Volvocineæ. The Chlorophyceæ are divided into Confervoideæ, Siphonæ, Protococcoideæ, and Conjugatæ; and the isogamous Confervoideæ again into Chætophoraceæ, Cladophoraceæ, Trentepohliaceæ, and Ulvaceæ. The Protococcoideæ are again divided into Volvocineæ, including the new genus *Cylindromonas*, and Palmellaceæ, with which the Protococcaceæ are united. Under the Protococcaceæ is placed the new subfamily Coccaceæ which includes a number of forms regarded by the author and others as stages in the development of higher algæ. A number of new species and varieties are described. Some further details are given in another paper.\*

**Hauck and Richter's Phycotheca universalis.**—Three parts of this valuable publication are now issued. Each contains a specimen of 50 species belonging to every class of algæ, many of these being rare and difficult to obtain. The synonyms of each species are given in detail, and the locality whence the specimen was obtained.

**Venetian Chlorophyceæ.**†—The third part of De Toni and Levi's 'Flora Algologica della Venezia' is devoted to the Chlorophyceæ, the authors following almost entirely the classification of Rabenhorst. The members of each genus, as well as of the larger groups, are arranged in an analytical key.

**Chætoceros.**‡—Herr F. Schütt describes the structure of this genus of Diatomaceæ, of which several species are at times exceedingly abundant in the Baltic, floating free on the surface of the water. The cell-wall consists usually, as in *Melosira*, of only three pieces, the two valves and a single girdle, and the genus is distinguished from all others by the very long horns, a pair of which spring from each end of each cell. They are not above 1/20 the diam. of the cell, but many times as long. They are continuations of the cell-wall, and are, like it, strongly silicified, the cell-contents being in unbroken communication; and they may even contain chromatophores. The separate cells which result from the division of a single mother-cell usually remain for a time attached to one another in chains, the mucilaginous substance which connects them together being apparently formed between the horns. In the process of cell-division the horns do not begin to make their appearance, as small papillæ, until the young cells have nearly separated from one another.

Like many other genera of diatoms *Chætoceros* is characterized by the formation of "internal cells" or resting spores, formed singly in the mother-cells. They are formed by the contraction of the contents of the mother-cell, which retreat from the cell-wall and round themselves off, secreting at the same time a new cell-wall which is provided with spines or protuberances. These are not, like the horns, hollow, but are solid silicified rods. The horns of the mature cell vary greatly in form and size in different species of the genus, and even within the same species.

**Varieties of Aulacodiscus.**§—Mr. J. Rattray supplements his monograph of this genus|| by a description of abnormalities which occur in the different species in the following points:—(1) Outline:—the ordinary

\* Oesterr. Bot. Zeitschr., xxxviii. (1888) pp. 41-4, 87-9, 114-7, 149-51.

† De Toni, G. B., e D. Levi, 'Flora Algologica della Venezia. Parte terza, Le Cloroficee,' 206 pp., Venezia, 1888.

‡ Bot. Ztg., xlv. (1888) pp. 161-70, 177-84 (1 pl.).

§ Journ. of Bot., xxvi. (1888) pp. 97-102 (1 pl.). || This Journal, ante, p. 337.

circular outline becomes occasionally polygonal, and normally so in *A. polygonus*. (2) Surface:—elevations and inflations of various kinds occur in different species. (3) Colour:—differences of colour in mature valves depend on the thickness of the valve, those having the superficial layer absent from certain portions being lighter there than elsewhere. (4) Central space:—in some species the central space is uniform in outline and dimensions, while in others it varies. (5) Markings:—variations are constantly met with in the degree of distinctness of the individual markings, arising from their greater or less elevation above the general surface. (6) Primary rays:—the number of these is extremely variable, from entire absence in abnormal forms of *A. Kittoni* to 45 in *A. orientalis*, and they are far from constant even in the same species. (7) Processes:—these vary in their distance from the circumference, and are altogether wanting in *A. apedicellatus* and *A. suspectus*, and in abnormal forms of *A. Kittoni*.

### Fungi.

**Blue Coloration of Fungi by Iodine.\***—M. L. Rolland records several instances in which the tissues of Fungi give the blue reaction with iodine alone. This occurs with the hairs and fibres of the stipes of *Mycena tenerrima*, a small agaric growing on the bark of poplars in the neighbourhood of Paris; also in the spores of *Cyphella vitellina*, a new Hymenomycete from Chile.

**Classification and Description of Fungi.†**—Herr H. Karsten comments on and criticizes various points in Winter's Monograph of the German Fungi in Rabenhorst's 'Cryptogamen-Flora von Deutschland'; some details of the classification adopted, and also the terminology, nomenclature, and synonymy.

**Biological Studies of Fungi.‡**—M. P. Vuillemin describes a new *Eutonophthora*, *E. glæospora*, parasitic on flies. The mycelium is formed of elongated branched filaments, with here and there dense tufts of hyphæ, which ramify several times, each of the ultimate branches forming a spore at its apex; the spores give birth, on germinating, either to sporidia or to a mycelium. The mycelial filaments are unseptated, but contain a number of nuclei dispersed with great regularity, each segment containing several. Each spore contains a nucleus, which passes into the sporidium when this is formed from it.

After an account of the life-history of *Mucor heterogamus*,§ M. Vuillemin describes two new species of the genus:—*M. neglectus*, a very small species, with the sporangiophores branching in a sympodial manner, and *M. ambiguus*, with coiled sporangiophores resembling those of *Circinella*. He states that the sporangium of *Mucor* does not dehisce at all when the atmosphere is very dry.

Further notes follow on some species of Ascomycetes. The author confirms Tulasne's statement that *Trichoderma viride* is a conidial form of *Hypocrea rufa*. The name *Melanospora Fayodi* he gives to a fungus growing on *Leotia lubrica*, which had been called by Fayod *Hypomyces Leotiarum*; he has observed its ascospores, and has also discovered

\* Bull. Soc. Mycol. France, 1887, p. 134. See Rev. Mycol., x. (1888) p. 49.

† Flora, lxxi. (1888) pp. 49-61, 65-80.

‡ Bull. Soc. Sci. Nancy, 1887. See Morot's Journ. Bot., ii. (1888) Rev. Bibl., p. 13.

§ See this Journal, 1887, p. 281.

sclerotia on it. *Peziza mycetophila*, which grows in its conidial form on *Lactarius vellereus*, is known, not only in its pezizoid, but also in its conidial form as *Monilia albo-lutea*, and as a sclerotium. When the sclerotium germinates, it gives birth not to a fructification, but to a mycelium. In *Saccobolus depauperatus* the whole membrane of the ascus is coloured an intense blue by a solution of iodine.

**Formation of two fertile hymenia in *Polyporus applanatus*.\***  
—M. E. Heckel describes a specimen of *Polyporus applanatus* with a double hymenium. The first hymenium, which was normal, was more developed than its congener situated on the opposite side of the same pileus. The second hymenium, which was formed of short oblique tubes, was less than half as thick as the former. The most remarkable fact about this monstrosity was that the two hymenia were both fertile, though so different.

**Stretching of the Receptacle of the Phalloidei.†**—Herr E. Fischer has investigated the cause of the remarkably rapid extension of the receptacle of the Phalloidei, by which the volva is burst, and the mass of spores raised up. The observations were made chiefly on *Phallus impudicus*, but the explanation probably applies to the other species also.

The extension is well known to be accompanied by a smoothing out of the previously folded or plaited walls of the chambers of the receptacle; and De Bary attributes this to the inflation of the chambers by air. Herr Fischer does not consider this explanation adequate. He suggests that the folding of the walls is due to their rapid growth, while the extension of the stalk is prevented by the surrounding tissue. The cells which lie on the concave side are thus arrested in their growth, and become extremely compressed. As soon as the pressure is removed by the severance of the connection with the surrounding tissue, the tension causes a sudden smoothing out of the walls of the chambers, and a corresponding increase in their size; and this is no doubt assisted by the entrance of air into the chambers, which probably at first takes place from the intercellular spaces of the surrounding tissue.

**Revision of the Genus *Bovista*.‡**—Mr. G. Masee gives a diagnosis of the genus *Bovista*, and also descriptions of thirty-nine species, several of them new. Although allied to several genera, it has perhaps the most affinity with *Lycoperdon*, the points of difference between the two genera being that in *Bovista* the cortex is free, and falls away in patches, the sterile base is absent, and the capillitium springs from every portion of the inner wall of the peridium; while in *Lycoperdon* the cortex becomes broken up into warts or spines, the sterile base being present. The author subdivides the genus *Bovista* by means of spore characters:—  
(a) Spores globose, warted or spinulose. (b) Spores globose, smooth.  
(c) Spores elliptical. (d) Species in which information about the spores is wanted.

**Formation of the Asci in *Physalospora Bidwellii*.§**—M. Frèchou states that since the black rot was noticed on the vines in France, in 1885, by MM. Viala and Ravaz, only the æstival forms of the parasite had been studied. Towards the end of June, at Nerac, shortly after the

\* Rev. Mycol., x. (1888) pp. 5-6.

† MT. Naturf. Gesell. Bern, 1887 (1888) pp. 142-57 (6 figs.).

‡ Journ. of Bot., xxvi. (1888) pp. 129-37 (1 pl.).

§ Comptes Rendus, cvi. (1888) pp. 1361-3.

appearance of the first spots on the leaves, the fungus propagated itself by the aid of spores contained in receptacles (pycnidia). These spores are ovoid and colourless, and easily germinated when the necessary conditions of heat and humidity were furnished. It appears that the fungus always attacks the leaves first; the spores are then conveyed from the leaves to the grapes by rain. Besides the pycnidia, other smaller receptacles may be seen; these are the spermogonia which contain the spermatia. The rôle of these organisms has not yet been determined in a satisfactory manner.

**Development and Fruetification of Trichocladium.\***—M. L. Dufour states that *Trichocladium asperum* Harz, consists of long, colourless, branched filaments, and on these are short ramifications which terminate in a single spore. This spore is formed of two cells, the lower of which, although smaller at first, gradually becomes as large as the upper one. They are at first colourless, then brown, and finally black, and are tuberculated when mature. The author found that the liquid best suited for the culture of this fungus was neutralized orange-juice.

The commencement of germination took place in twenty-four hours after sowing. From one of the two cells of the spore, or sometimes from both, a small colourless vesicle may be seen to grow, from which arise some short and slightly branched germinating filaments. The mycelium then increases, branching abundantly. The important points to notice are that the mycelium is not septated, and that the spore is bicellular, black, and warty.

**Ceratomyces and Fibrillaria.†**—According to M. J. de Seynes *Fibrillaria* consists of radiform threads analogous to the mycelium of *Clathrus* and *Phallus*, ramifying and anastomosing in a manner somewhat similar to *Rhizomorpha*, from which however it differs in colour; *Rhizomorpha* being black, and *Fibrillaria* white, or yellowish white. Certain specimens of *Fibrillaria* exhibit irregular nodosities along the course of the radiform threads. These bodies have been described under the name of *Ceratomyces* by Corda. The author has, however, been able to determine the complete identity of *Ceratomyces* and *Fibrillaria*.

**New Genus of Sphæriaceous Pyrenomyces.‡**—Sig. P. A. Saccardo gives descriptions of two species which form a new and very remarkable type of Pyrenomyces. The following is the diagnosis of the genus:—

*Berlesiella* Saccard. Perithecia subcarbonacea, atra, globosa, stromate pulvinato vel hemispherico, v. effuso carbonaceo, inserta, discreta vel basi tantum connexa, botryoso-prominula, setosa, ostiolo minuto vel obsolete. Asci clongati (spurii paraphysati, octospori). Sporidia ovoideo-oblonga, 2-pluri septata et muriformia, c hyalino flaveola.

*Berlesiella nigerrima* grows on *Prunus Padus*, and is often parasitic on the perithecia of *Eutypella padina*; *B. hirtella* grows on the branches of *Sambucus*, near Rome.

**New Genus Peltosphæria.§**—Sig. A. N. Berlese gives the diagnosis of a new genus of sphæriaceous Pyrenomyces, to which he gives the name of *Peltosphæria*:—

Perithecia sparsa epidermide tecta et basi ligno infossa, sursum clypeo stromatico atro tecta, raro bina sub eodem clypeo. Ostiola vix

\* Bull. Soc. Bot. France, xxxv. (1888) pp. 139-44.

† Rev. Mycol. x (1888) pp. 6-8 (1 pl.).

‡ Ibid., pp. 124-7.

§ Ibid., pp. 17-8 (1 pl.).

erumpentia, brevia. Asci cylindracei sessiles, paraphysati, octospori. Sporidia monosticha ovoidea, septata, muriformia. The author describes one species, *P. vitrispora* Berl., which grows on the branches of a Californian *Lonicera*.

**New Mucedineæ.\***—M. Boudier describes a new fungus *Isaria cuneispora*, which he finds parasitic on the dead bodies of spiders; also another new species, *Stilbum viridipes*, on decaying chips of oak.

**Clathrospora and Pyrenophora.†**—Sig. A. N. Berlese follows up his monograph of *Pleospora* † with those of the two allied genera *Clathrospora* (8 species), and *Pyrenophora* (27 species). In both genera the primary divisions of the genus are made to depend on the number of septa and on other characters drawn from the structure of the sporidia.

**New Papulaspora.§**—Under the name *P. Dahlizæ*, M. J. Costantin describes a new species of *Papulaspora* found on the tuber of a dahlia. It appears to be a form of the genus *Dactylaria*, and produces a number of spherical bodies, somewhat of the nature of sclerotia, which have the power of germination, each cell of the spherule giving rise to a germinating filament.

**Schinzia.||**—Herr P. Magnus gives a revised diagnosis of this genus of Fungi (*Entorrhiza* Weber), with descriptions of two new species:—*S. Aschersoniana*, on the root-swellings of *Juncus bufonius*, and *S. Casparyana*, on the same organs of *J. Tenageia*.

**Fungus Parasitic on the Plane.¶**—M. C. Roumeguère speaks of the ravages committed on plane-trees in the south of France by the attacks of a parasitic fungus *Fusarium ramulorum*. It is the conidial form of a well-known Ascomycete *Calonectria pyrochroa*; both forms may sometimes be found on the leaves or young branches of the same tree.

**Anatomy of the Common Cedar-apple.\*\***—Mr. E. Sanford states that this species of cedar-apple (*Gymnosporangium macropus*) originates in the leaves of the smaller branches of *Juniperus virginiana*. The mycelium of the fungus causes an abnormal growth in the leaf-tissue, which carries up the apex of the leaf as it develops, and pushes the branch to one side until the knot itself appears to be terminal. About the 1st of May the mycelium of the fungus collects in masses a little beneath the surface, raising it up into little papillæ. Later, the surface of the knot is broken through at these points, and yellow cylindrical masses, composed of spores borne upon long hyaline and more or less gelatinous stalks, are protruded, and when moist swell up, and often extend to the length of nearly an inch. The author then describes in detail the changes which take place in the leaf as the result of the attack of the fungus. The most striking of these is the great multiplication of cells which takes place, and their generally enlarged size.

\* Rev. Mycol., ix. (1887) pp. 157-9 (1 pl.).

† Nuov. Giorn. Bot. Ital., xx. (1888) pp. 193-260 (4 pls.).

‡ See this Journal, ante, p. 469.

§ Morot's Journ. Bot., ii. (1888) pp. 91-4 (1 pl.).

|| Ber. Deutsch. Bot. Gesell., iv. (1888) pp. 100-4 (6 figs.).

¶ Rev. Mycol., ix. (1887) pp. 177-9.

\*\* Ann. of Bot., i. (1888) pp. 263-8 (1 pl.).

## Protophyta:

**Cellular Envelope of the Filamentous Nostocaceæ.\***—M. M. Gomont differs to a certain extent from the conclusions of Borzi † with regard to the nature of the envelope immediately surrounding the cell in the filamentous Nostocaceæ, which is stated by Borzi to be inseparable from the protoplasm, and to pass insensibly into it. According to M. Gomont, writers have hitherto confounded the envelope proper of the cell with the mucilaginous sheath of the trichome. Taking as a favourable example *Scytonema myochrous*, he finds that the mucilaginous sheath can be rapidly dissolved by chromic acid of a strength of from 33 to 50 per cent., with the exception of a very thin external pellicle, the very thin perfectly transparent envelope proper of the cell being also left behind. This appears to possess properties intermediate between those of the membrane of the hyphæ of fungi and those of vegetable cutin. It displays a remarkable power of resistance to acids; it is unaffected by the action for twenty-four hours of chromic acid of 33 per cent., or of concentrated sulphuric acid; chromic acid of 50 per cent. dissolves it in a few hours. It is insoluble in potash; with iodine reagents it never takes a blue colour, but remains uncoloured or takes a light yellow tint. It takes up anilin dyes, especially fuchsin, with great avidity.

**Development of *Mischococcus confervicola*. ‡**—Prof. A. Borzi has followed out the life-history of this Protophyte more fully than previous observers. The ordinary dendroidal form, in which each branch consists of two nearly spherical cells supported on a gelatinous stalk, is commonly found attached to algæ and other water-plants. The cells have thin smooth cell-walls giving the reaction of cellulose. Each has from two to four chromatophores without pyrenoids, and a nucleus. In addition to the ordinary dendroidal, *Mischococcus* has also a palmelloid form, in which it spreads itself as a thin layer over the surface of the substratum, dividing in two directions only; the cells being in comparison twice as large or larger. The cells of the palmelloid form finally give birth to zoospores, sometimes one, more often two or four, from each cell. Each zoospore has a red pigment-spot, and a single very delicate cilium. On germinating they again give birth to palmelloid colonies. The dendroidal colonies are the result of a tendency of certain cells in the palmelloid colonies to divide in a direction parallel to the substratum; or more often they are derived directly from the germination of zoospores. The cells of the dendroidal colonies also give birth to zoospores, either one or two from each cell, which may be described as microzoospores, in contrast to the somewhat larger macrozoospores resulting from the palmelloid colonies; otherwise they are identical with them. Sig. Borzi is satisfied that, at least under certain conditions, these microzoospores are zoogametes, conjugation taking place between them; the zygozoospores resulting from the conjugation have at first two cilia.

***Stichococcus bacillaris*. §**—Herr G. Lagerheim describes a variety of this organism, *β fungicola*, growing on various Polyporeæ, and distinguished from the normal form by its cells being oval instead of cylin-

\* Morot's Journ. Bot., ii. (1888) pp. 43-8.

† See this Journal, 1887, p. 448.

‡ Malpighia, ii. (1888) pp. 133-47.

§ Flora, lxxi. (1888) pp. 61-3.

drical. It is of interest in reference to the question of the polymorphism of the Chlorophyceæ, exhibiting evidently a change of form resulting from altered vital conditions, since all intermediate stages occur between the typical and the varietal form. *Stichococcus bacillaris* assumes a similar form when it occurs as gonidia in the lichen-thallus of the Calicieæ.

**Remarkable Flos-aquæ.\***—Dr. G. B. De Toni records the observation of a remarkable scum or “flos-aquæ” observed on the surface of the water in an aquarium in the botanic garden at Parma. It consisted of an enormous number of biciliated zoospores in very active motion, which apparently could not be derived from any *Cladophora* or other alga belonging to one of the higher groups. On germinating the zoospores gave birth to a pseudo-pediastroid organism apparently identical with *Dictyosphaerium Ehrenbergianum*.

**Composition of “Muffe.” †**—Prof. E. Perroncito and Dr. L. Varalda have examined the nature of the substance known as *muffe* (mould) used largely for curative purposes in the district of Valdieri in Piedmont. It is found as a scum on the surface of hot springs of a temperature from 56° to 69° C. more or less impregnated with sulphuretted hydrogen, and is largely cultivated on the surface of wet inclined rocks. They find it to consist almost entirely of *Leptothrix valderia*, among which are interspersed filaments of an *Oscillaria* and cells of a *Glæocapsa*. The filaments of the *Leptothrix* have a diameter of from 0·8–1·0  $\mu$ .

**Saccharomyces minor. ‡**—Sig. G. Arcangeli maintains that this organism is the chief factor in panic fermentation. It differs from *S. cerevisiæ* chiefly in the size of its cells, which are considerably smaller. He describes various nutritive media on which he was successful in obtaining pure cultures of this ferment:—a mixture of gelatin and honey, Koch's nutrient gelatin, and agar-agar. In Koch's gelatin and agar-agar, it develops chiefly on the surface of the substratum, forming a white scum.

The author obtained an organism closely resembling *S. minor*, and apparently identical with it, from the fermentation in water of the aril of the seeds of *Euryale ferox*, which contain a large quantity of mucilage.

**Spores of the Ferments.§**—M. E. Wasserzug states that in 1868 the spores of what was known under the name of *Mycoderma vini* were observed for the first time by M. de Seynes. Shortly afterwards Reess cultivated various species of the genus *Saccharomyces*, not in a liquid, but on slices of carrot, or potato, and found that the spores formed easily. On account of their endogenous formation, and because there were usually four in a cell, Reess placed the *Saccharomyces* among the lower *Ascomycetes*. The author's method for studying the spores of the *Saccharomyces* is to sow them on small pieces of filter-paper. Sterilization having been effected, the spores begin to form in about twenty-four hours at a temperature of 25°. The author was able to study ten species obtained from various kinds of wine and beer; in each case purification was made with care by successive cultures on gelatin. In order to render the ascospores plainly visible, a weak solution of eosin

\* Nuov. Giorn. Bot. Ital., xx. (1888) pp. 295–7.

† Notarisia, ii. (1887) pp. 333–7.

‡ Nuov. Giorn. Bot. Ital., xx. (1888) pp. 303–6.

§ Bull. Soc. Bot. France, xxxv. (1888) pp. 152–7.

may be used; the spores then detach themselves, and are coloured deep-blue, the cells of the ferment being rose-coloured.

**Symbiosis of Bacteria with *Glæocapsa polydermatica*.**\*—Dr. A. Tomaschek replies to Kronfeld's criticism † on his previous paper on this subject. Although the symbiosis is not of so intimate a character as that which takes place in the union of an alga and a fungus or Schizomyceto to form a lichen, it is nevertheless quite distinct from true parasitism. He maintains the identity of the bacterium with *Bacillus muralis*.

**Presence of a Phlogogenous matter in the Cultures of certain Microbes.**‡—M. S. Arloing states that there exist in the nutritive media in which microbes have been artificially cultivated certain toxic substances capable of reproducing more or less exactly the symptoms of the malady caused by the microbes. M. Pasteur found these poisons in the cultures of the active principle of chicken-cholera, and M. Charrin in those of *Bacillus pyocyaneus*. The properties of this phlogogenous substance show some interesting peculiarities. It manifests its maximum activity at a temperature of 80°. It still possesses a noticeable influence when it has been submitted to a temperature of 110° for a quarter of an hour. Finally, its effects do not operate with the same intensity on the various domestic animals on which it has been tried.

**Chromo-aromatic Microbe.**§—M. Galtier describes the properties of a microbe obtained from the ganglia of a young pig.

Cultures were made on agar, gelatin, and potato, and at the end of twenty-four, thirty-six, or forty-eight hours, a yellowish-green colour was observed; this colour gradually became deeper, and was slightly different with the different materials used. The cultures of this microbe were also aromatic. The odour which was exhaled was very pronounced, and was an odour *sui generis*, strong, but rather agreeable.

**Sarcina of the Lungs.**||—Herr G. Hauser records the interesting discovery of the endogenous formation of spores in a micrococcus. It occurs in a *Sarcina* obtained from the lungs in pneumomyeosis, consisting of cocci always united in groups of 2 or 4, instead of 8, as in Fischer's pneumomyeosis-sarcina. It forms on gelatin patches of a pearly-grey colour, extending over the surface, but not liquefying the gelatin. Certain isolated cells contain, at a particular moment, strongly refringent corpuscles, at first surrounded by a membrane which gradually gelifies, and sets the corpuscles at liberty. In this state they present the properties of ordinary spores. These spores are readily demonstrated by heating the preparation in an aqueous solution of fuchsin, and decolorizing by sulphuric acid of 25 per cent.; the spores alone resist the decolorization; they may then be re-stained by methylene-blue. They can be heated to 110° C., without destroying their power of germinating even after the lapse of three years.

**New Pathogenic Microphyte in Men and Animals.**¶—Dr. G. Bordoni-Uffreduzzi relates a case in which the post-mortem appearances,

\* Oesterr. Bot. Zeitschr., xxxviii. (1888) pp. 134-6. Cf. this Journal, 1887, p. 785.

† See this Journal, 1887, p. 996.

‡ Comptes Rendus, cvi. (1888) pp. 1365-8.

§ Ibid., pp. 1368-70.

|| Münchener Med. Wochenschr., 1887, p. 545. See Bull. Soc. Bot. France, xxxv. (1888), Rev. Bibl., p. 5.

¶ Centralbl. f. Bacteriol. u. Parasitenk., ii. (1887) pp. 33-4.

&c., resembled those of anthrax, but were yet sufficiently different to warrant a careful examination.

Cultivations from the mesenteric glands resulted in the isolation of a micro-organism which resembled, but was not identical with, anthrax bacillus. As the microphyte was found in the other organs of the body, and in those of inoculated animals, it was regarded as the cause of the disease. The animals inoculated from pure cultivations were dogs, rabbits, guinea-pigs, and white mice. In morphological characteristics it resembles *Proteus* to some extent. According to the various nutritive media, the micro-organism grows in the culture sometimes as long jointed or unjointed threads, sometimes as encapsuled rodlets and roundish corpuscles. The name proposed by the author for his new microphyte is *Proteus hominis*.

**Dissemination of Bacillus by Flies.\*** — MM. Spillmann and Haushalter call attention to some observations made by them which show that flies may be of injurious importance in the dissemination of the bacillus of tuberculosis.

They captured some flies from the vessels containing the expectorations of patients suffering from tuberculosis. These flies soon died, and examination showed the presence of abundant bacilli of tuberculosis both in their excrement and in their abdominal cavities. Since the flies die and crumble to dust in odd corners, the bacilli may be readily liberated, and the germs may also be landed along with the excrement on articles of food and clothing. While it is not yet known how the life within the fly may affect the vitality of the bacilli, it seems at least advisable that the precaution should be taken of covering and of sterilizing the vessels containing the expectorations of tuberculosis.

\* Comptes Rendus, cv. (1887) pp. 352-3.



## MICROSCOPY.

## a. Instruments, Accessories, &amp;c.\*

## (1) Stands.

FIG. 96.

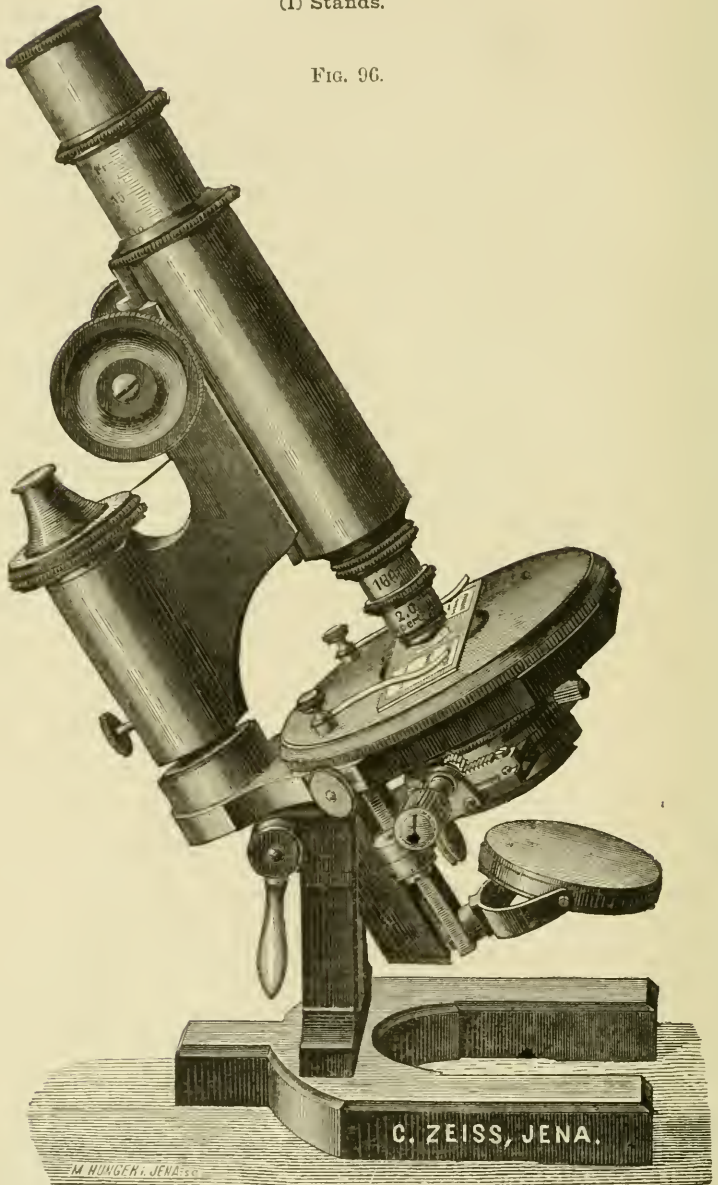

\* This subdivision contains (1) Stands; (2) Eye-pieces and Objectives; (3) Illuminating and other Apparatus; (4) Photomicrography; (5) Microscopical Optics and Manipulation; (6) Miscellaneous.

**Zeiss's IIa. Microscope.**—Dr. C. Zeiss's new stand IIa. (fig. 96), resembles his No. II. in general form and dimensions, but differs from it in having the fine-adjustment described in this Journal, 1887, p. 150. The upper part is not made to rotate about the optic axis as in No. II., but there is instead a disc of vulcanite which rotates on the stage; this is centered by means of two screws working against springs, one of which is shown in the figure immediately below the right-hand clip. The play of the centering screws is said to be sufficient to answer the purpose of a mechanical stage with high powers. The stage is large enough for cultivation plates. The Microscope inclines and can be clamped in any position.

The Abbe illuminator is provided with an Iris-diaphragm. The optical system (1.40 N.A.) is fixed in a brass holder which fits into a corresponding sliding socket, so that it may be withdrawn without difficulty from below, and replaced by a cylinder diaphragm or any other appliance similarly fitted (photographic condenser, illuminator for monochromatic light, microspectral-objective, spectral-polarizer, &c.).

The height of the stage above the base of the stand is reduced as far as possible for two reasons: (1) in order that the hands of the observer while manipulating the object may rest easily upon the stage, which is not the case with the stands of larger dimensions; (2) because a low stand is more convenient for most observers, and makes the instrument more portable.

**Babuchin's Microscope.**—This stand (fig. 97), is made by Dr. Zeiss, after the design of the Moscow histologist Prof. A. Babuchin.

The Abbe illuminator has almost the form adopted by M. Nachet; the optical system, fixed in a holder, can be inserted from above into the carrier, which can be screwed downwards and swung out to the left. By these means the lenses are most easily interchanged with those of different aperture, or with a cylinder diaphragm, or polarizer. Below the condenser is a slot made to rotate about the optic axis in which the iris-diaphragm with rack and pinion is inserted; for oblique illumination it can be adjusted eccentrically. The illuminator is moved in the optic axis, not, as is generally the case, by rack and pinion, but by a screw fitted to the left under side of the stage, which gives a slower and more exact motion. When the screw has been turned until the illuminator has reached the lowest point, a further turn swings it out to the left.

A specially large mirror is fixed to a sliding carrier by which it may be raised or lowered, or, when the condenser is swung to one side, fixed in any oblique position. The stage, which is not made to rotate or move, is large enough for cultivation plates.

The upper part of the stand is attached by a hinge-joint to a short pillar, which slides in a tube on the base, so that it can be drawn out and clamped. This renders it possible to lower the stage as much as is required for convenient manipulation or portability, or to increase the height of the stage and stand if this is required for application to a photographic camera, or to admit a larger substage, &c. The height of the stand can be varied between 200 and 230 mm., and that of the stage from 105 to 135 mm. It has the adapter for changing objectives which was described in this Journal, 1887, p. 646, and the fine-adjustment described p. 150.

FIG. 97.

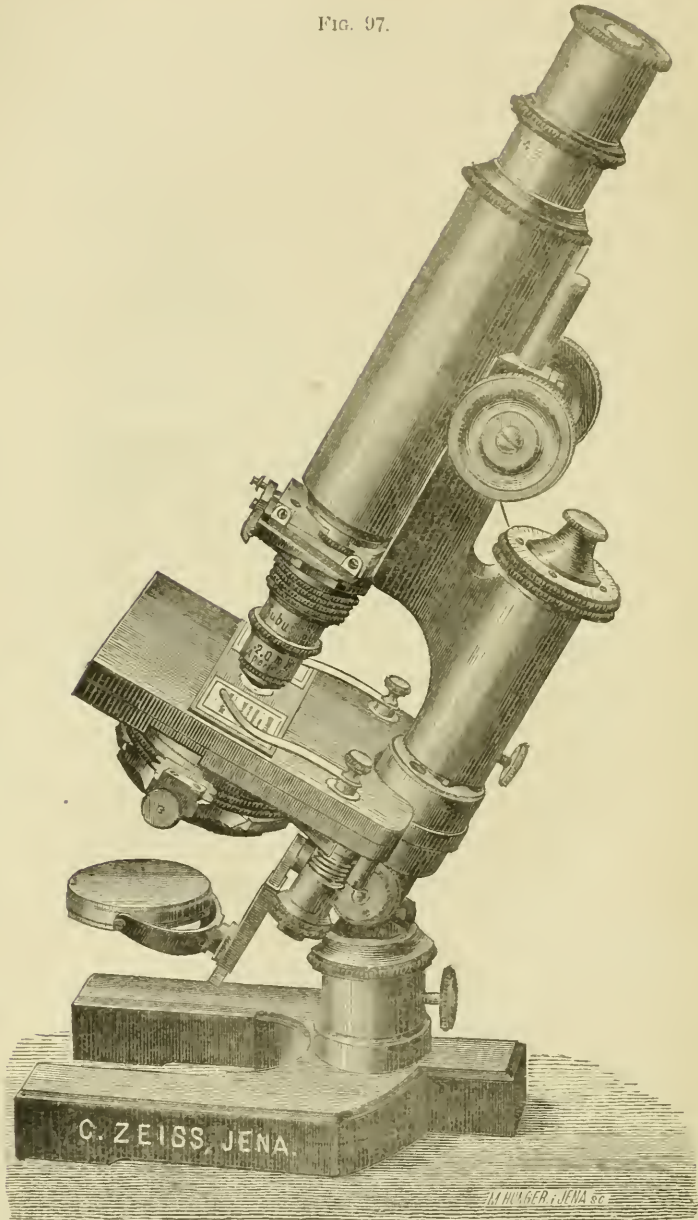

BAEUCHIN'S MICROSCOPE.

**Galileo's Microscopes.**—In the "Museo di Fisica," at Florence, are two small Microscopes made wholly of brass, which Professor Meucci (Curator of the Museum) informs us are considered to have been constructed by Galileo (*ante* 1642), they having been handed down from the days of the "Accademia del Cimento," always bearing the traditional association of Galileo's name, and forming part of the collection of instruments belonging to that Academy at the date of its dissolution (1667). By the courtesy of Professor Meucci we were enabled recently to photograph the instruments, whence our figs. 98 and 99 are reproduced.

The two Microscopes are of essentially the same design, differing only in the shape of the scroll tripod supports, and in the fact that one is provided with a cap over the eye-lens.

As the lenses are wanting in both instruments, we are not able to determine whether the eye-lens was of the convex (Keplerian) or the concave (generally known as the Galilean) form. For focusing there

FIG. 98.

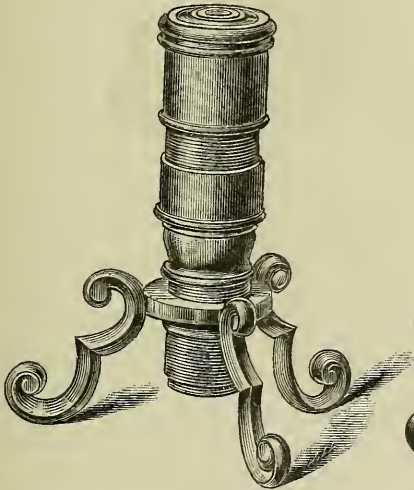
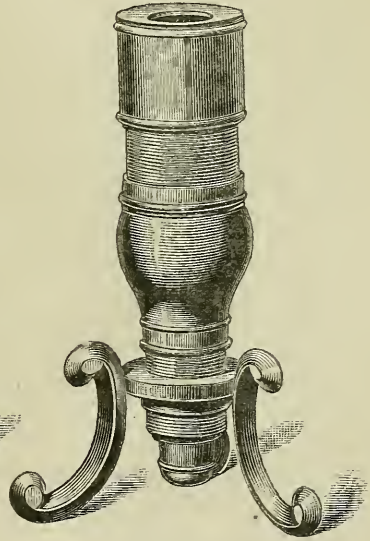

FIG. 99.



are two screw adjustments, one for distancing the whole optical-body from the object, and the other for regulating the distance of the eye-lens from the objective, as in the Campani Microscopes we recently figured.\* The absence of any kind of stage would imply that the examination of opaque objects was principally intended.

Apart from the late Professor Harting's conjecture regarding the possible origin of the so-called "Janssen" Microscope,† and on the supposition that these instruments were really made by Galileo, they must be regarded as the earliest Compound Microscopes in existence.

\* See this Journal, 1886, p. 643, and 1887, p. 109.

† See this Journal, 1883, pp. 708-9.

One of the Microscopes was exhibited at the Loan Collection of Scientific Instruments in London in 1876.

**Joblot's Microscope.**—In the same Museum referred to in the preceding note we also found the Microscope shown in fig. 100, which is

FIG. 100.

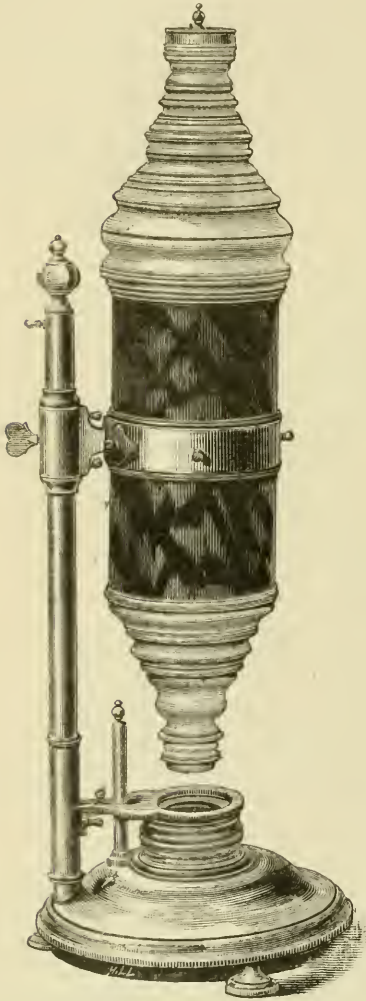

constructed of ivory, tortoiseshell, and brass. It bears no name, and no record of its origin is contained in the Museum. From the ornate character and general resemblance to a Microscope figured by Joblot\* we think it probable that he was the maker.

For the coarse-adjustment the socket slides on the pillar; the fine-adjustment is by means of a screw passing down the pillar to the stage-socket, and is actuated by the shaped knob on the top.

**Hensoldt's Reading Microscopes.**†—Herr M. Hensoldt has published an elaborate article "On Reading Microscopes in general, and on screw Microscopes, and the scale Microscopes of the author in particular."

The great advantage of Microscopes over verniers in reading divided circles and scales, consists in the greater magnifying power of the Microscope as compared with the lens of the vernier, as well as in obviating parallax, and the possible eccentricity of the latter. While the lens only possesses a magnifying power of 8-10 (and those of greater power cannot well be employed), the Microscope can easily be used with a power of 40-60, which means a 5-7-fold increase of efficiency. For if the interval between two divisions is increased 5-7-fold by optical means, the intermediate positions or subdivisions can be estimated with greater certainty in the same proportion. With screw Microscopes in which the subdivisions are measured by

the turns of the screw, the hundredth or sixtieth part of such a division is determined with greater certainty in proportion as the magnitude of

\* 'Descriptions et usages de plusieurs nouveaux Microscopes, tant simples que composez,' &c., par L. Joblot, Paris, 1718, fol., pl. 14.

† Central-Ztg. f. Opt. u. Mech., viii. (1887) pp. 242-6 (3 figs.).

the hundredth or a sixtieth of a turn can be recognized with greater accuracy; otherwise the reading of the drum is merely illusory. If the magnifying power of the Microscope is small, and the pitch of the screw very shallow, the hundredth parts which are read are only approximately true, and different results will be obtained from repeated observations, because the small size of the hundredths in the image cannot be clearly distinguished. With stronger magnifying power a screw of greater pitch can be used, and the hundredth parts can be more clearly determined. With scale Microscopes of high power, the micrometer divisions are more widely separated, and their tenths or half-tenths can be estimated with proportionally greater accuracy. The latter also possess, besides great simplicity, the advantage of rapid reading. While, with the vernier and lens, it is necessary to search a length of divisions for the coincident lines; and with the screw Microscope, the distance of the cross wire from the nearest division must be measured by rotating and reading the screw-head; with the scale Microscope, a single glance is enough to show how many minutes, tenths, &c., are to be added to the nearest division.

Considering the accuracy attainable with scale Microscopes, and the inconvenience attaching to screw Microscopes with their high power and consequent loss of light, the latter must be regarded as inferior to the former, unless means are devised for improving their optical character to the same extent.

In the author's opinion screw Microscopes are generally made too long (and too heavy), in which there is no advantage, for, (1) the instrument becomes large and inconvenient, and (2) the efficiency is not increased, but diminished. In Microscopes used for scientific observations where the greatest efficiency and strongest magnifying power are necessary, it has long been known that the best results are obtained from powerful objectives combined with weak eye-pieces. Their short focal length necessitates close approximation to the object, involving increased aperture and greater intensity of light. Since, here as with telescopes, increase of light means increased efficiency, this is of particular importance in the present case where the object is opaque and cannot be satisfactorily illuminated. But as with the telescope, so here in greater degree, it is impossible to retain the same relation between focal length and apertures for all focal lengths. Short focal lengths involve much greater apertures than long; both with a single objective lens and with a compound system. Thus the most powerful dry systems of 2.8 and 1.85 mm. equivalent focal lengths can have an aperture of  $116^\circ$ ; while with 4.3 mm. focal length, the latter falls to  $74^\circ$ , with 7 mm. to  $50^\circ$ , with 11 mm. to  $40^\circ$ , with 18 mm. to  $24^\circ$ , and with 27 mm. to  $20^\circ$ .

Half the aperture corresponds to one-quarter of the intensity of light; the latter varies as the square of the former. From this it follows that reading Microscopes with objectives of short focal length have the advantage. Since they give brighter images, they can have stronger magnifying power, and therefore greater efficiency, while at the same time they are shorter and more convenient.

To gain space for illumination, the objectives should consist of a single aplanatic lens. The following table gives the most convenient relation between aperture and focal length for such lenses.

The aperture is slightly diminished by the fact that the object is never strictly at the focus as is assumed in the table.

Focal Length.		Linear Aperture.	Angular Aperture.
lines.	mm.	mm.	degrees.
3	6.8	3.1	26.0
4	9.0	3.6	22.6
5	11.3	4.1	20.6
6	13.5	4.5	18.9
7	15.8	4.75	17.0
8	18.0	5.0	15.8
10	22.5	5.6	14.1
12	27.0	6.2	13.0
15	34.0	6.6	11.1
18	40.5	7.0	9.9
24	54.0	7.5	7.9

The intensity of light, taking that of the 3-line objective as = 1, is for the objectives of 6, 12, 18, 24 lines focal length, 0.53, 0.25, 0.144, 0.091 respectively.

With screw Microscopes, objectives of less than 8–15 lines focal length have rarely been employed, in spite of the advantages which they would realize. It is advisable with the strongest objectives, and even if possible with the others, to use orthoscopic eye-pieces which give greater definition of image near the borders of the field.

To test the relative advantages of short and long focal length in the objective, a comparison was made between a Microscope of the author's construction, and a theodolite Microscope, with an objective of 30 mm. focal length, 6.7 mm. free aperture, and (as it stood 38.6 mm. from the scale) 10° angular aperture. The magnifying power was 40 (objective 3.5 and eye-piece 11.3). The total length from the scale to the end of the eye-piece was 20.5 cm. The other Microscope had a length of 95 mm. from the scale to the end of the eye-piece, magnifying power = 50 (objective 3.6, eye-piece 14), focal length of objective = 5 lines, angular aperture = 20°. It was found that with the smaller Microscope the intensity of light was three times as great as with the larger.

There are cases in which for special reasons long Microscopes are desirable or necessary, as with dividing machines where the heat of the body is to be avoided, or where it is necessary to read from a distance. The angular aperture may here be increased by using an objective composed of two weaker lenses of greater diameter so as to gain light; or the tube may be lengthened by a terrestrial eye-piece (with erect image) without weakening the objective; or the light may be increased by setting the Microscope at an angle to the plane of the scale. This last contrivance, which is so convenient with vernier lenses, can only be applied to Microscopes to a limited extent. The inclined position serves to reflect light from the silvered scale into the lens or Microscope; so that the divisions appear as sharply defined black lines upon a bright white ground. In the normal position of the Microscope, when it is perpendicular to the scale, the angles of incidence and reflection must both be 90°, i.e. the light must come vertically downwards; this is effected by the illuminator. If the Microscope is inclined backwards the field is brighter, but the divisions are not visible in their whole length, but only in a small part. In practice, however, a backward inclination of 10° may be attained; the light incident between 80° and 90° is then reflected from the scale directly into the Microscope and

gives a much brighter field, while the above-mentioned objection, which in no way diminishes the accuracy of the measurements, has also a certain advantage; for since powerful Microscopes are very sensitive in respect of exact focusing, the plane of the scale must be accurately perpendicular to the axis of the Microscope, or the image will not remain clear during a complete rotation; whereas with the inclined position one part is always in focus.

Describing the special advantages of his own arrangement of the Microscope which has now been largely used since 1879, the author says: "The great advantage is simplicity; the few divisions of the micrometer are easily taken in by the eye, so that no other method of measurement is so rapid. Further subdivisions or transverse lines are unnecessary and troublesome, and do not increase the accuracy. A portion of the scale of the instrument is separated by the Microscope into 100 parts; one-tenth of these are read by the direct divisions of the micrometer, and the tenths of the latter by estimation. The reading is not conducted in any other way except for special purposes.

If, for example, a circle is divided by one-sixth of a degree, or at intervals of ten minutes, and the micrometer contains ten equal intervals which occupy exactly one division of the circle, each such interval corresponds to one minute. If the latter can by estimation be subdivided into tenths (by practice even into half-tenths) the unit of reading is six (or three) seconds. Fig. 101 shows the sixth division of a degree on the circle near the ten divisions of the micrometer. The divisions of the circle are numbered from degree to degree with 0 to 9, either by the pantograph or with figures made as small as possible and as near as possible to the lines so that at least one number shall be visible in the Microscope whose field covers more than one degree. It is not then necessary to use a special index or a lens to read the angle; for the principal numbers at each 10 degrees may be made large and placed outside the silver strip where they can be easily seen with the naked eye. If the circle is not covered the illuminator will at once show whether the reading is between 10 and 20 or 30 and 40, &c., and the single degrees are given by the divisions in the Microscope. If the circle is covered it will be necessary to have, in addition to the two small apertures for the Microscopes, a larger one inclosing about 15 degrees, at a point  $90^\circ$  from them, and having in the middle of its glass a black line by which the approximate angle is read off. Supposing that this line shows the reading to be between  $30^\circ$  and  $40^\circ$ , and that the micrometer stands as shown in the figure, the reading will be  $33^\circ 37'.3$  or  $33^\circ 37' 18''$ .

In the inverting Microscope the division on the circle always runs towards the long or zero mark of the micrometer, i. e. from left to right when the numbers of the horizontal circle run from right to left. The divisions of the micrometer are reckoned from zero point in the opposite direction, from right to left. With vertical circles where the numbers go from left to right, because the circle turns with the telescope, everything is reversed; in the right-hand Microscope alone the graduations are reckoned from right to left or downwards, and the micrometer divisions upwards; in the left-hand Microscope the graduations are read upwards and the micrometer downwards. For small instruments it is convenient to have the scale divided at intervals of 20 minutes; a micrometer division is then equivalent to 2 minutes; in this case it is

not necessary to take the mean of the two Microscopo readings since their sum will give the mean directly. A glance into the Microscopes is sufficient to give the mean of the readings and scarcely occupies a quarter of the time necessary for vernier readings. The scale graduations, which cannot be made so fine upon metal as the micrometer graduations upon glass, and which are magnified three to five times by the objective, appear much broader than the latter. With ordinary instruments which are finely divided a line on the scale covers at least

FIG. 101.



30 seconds to one minute, and from this fact would result a source of error if means were not found to obviate it. Instead of using the whole breadth of the mark the attention is confined to the same edge of it, namely that which is on the right-hand side towards the long mark. It is still better if the graduations terminate at one end in a point, such as is generally produced by the graving tool; but the pointed end should always be that at which the divisions are level, and not towards the prolongations of the whole degrees and half degrees. The tenths, &c., can then be very accurately estimated if the micrometer divisions project beyond the pointed ends (fig. 101)."

The divisions should be short (not more than  $1/2$  mm. in length), and as fine as possible; the exact coincidence of ten divisions in the micrometer with one division of the scale is secured as nearly as possible by preliminary calculations and then made absolute by a slight movement of the objective-tube.

With powerful Microscopes it is desirable to have some simple and

steady means of focusing; on this point the author says: "In place of the ordinary ring with clamp enclosing the Microscope tube, I apply above and below two segments *ll'* (fig. 102) which accurately fit the tube, most closely however at the edges, so that they are not quite in contact in the middle. The upper one, next to the eye-piece *O* and micrometer,

FIG. 102.

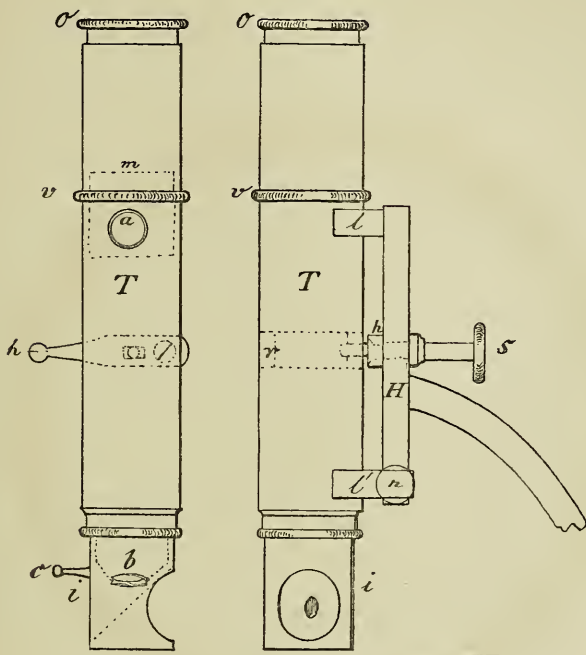

is only fixed to the holder *H* by a screw so that it can be turned slightly. The other, which is broader at its lower end, has a square pin, which passes through the holder, and is also secured by a screw; it can be slightly moved sideways by two milled head screws *n* to bring the reading accurately to 180°. Into the two bearings *ll'* the Microscope-tube *T* is placed and is held in position by a screw *s* which passes into the Microscope-tube; for this purpose a thick ring *r*, having a screw thread for *s*, is let into the tube. *s* is not to be turned so far as to fix the Microscope. Between *T* and *H*, and attached to the latter, is a small lever *h* turning on a screw; through this *s* passes and can be slightly raised or lowered by touching the end of the lever after slightly loosening *s*, which is finally screwed up tight. In this way I obtain a satisfactory fine-adjustment by simple means."

To clean the micrometer, if necessary, the upper part of the Microscope unscrews. The connecting-piece *v* contains the micrometer *m* which is to be adjusted parallel to the scale. This would generally be done by rotating the tube in the rings which hold it, but with the above fine-adjustment the tube cannot turn, and it is necessary to elongate *v* so that it passes down inside *T* and fits accurately in the lower part of the

tube and can be rotated with it. *m* is fixed in position by the screw *a*. The eye-piece is movable, to suit different eyes. The illuminator *i* is screwed to the holder of the objective *b*, and is turned towards the light by a small handle *c*. The scale should be covered with thin glass brought as near to it as possible in order that the illuminator may not be further from the scale than is necessary.

The author claims that his method of reading has also the advantage that errors in the dividing are at once detected by the failure of coincidence between the micrometer divisions and those of the scale, and he concludes with the results of some observations with a theodolite of 13.5 cm. diameter divided to one-third of a degree, which showed the mean error in an angular measurement to be  $\pm 3''$ , and the maximum error  $\pm 5''$ .

LEACH, W.—The Lantern Microscope.

[Cf. this Journal, 1887, pp. 1019–21.]

*Trans. and Ann. Rep. Manchester Micr. Soc.*, 1887, pp. 52–7 (1 fig.).

QUINN, E. P.—The Advantages and Deficiencies of the Lantern Microscope.

*Trans. and Ann. Rep. Manchester Micr. Soc.*, 1887, pp. 26–7.

### (2) Eye-pieces and Objectives.

Hartnack's new Objective.—We transcribe the following paragraph verbatim:\*

“A new objective, after calculations of Dr. Schröder, has been produced by Professor Hartnack, in Potsdam, whose microscopic objectives enjoy a well-deserved reputation, and which is destined to fill out the place between the photographic aplanat and the microscopic system. The weak microscopic systems, which are ordinarily applied, if more extended microscopic objects, histological preparations, polished stones, and metals are to be photographed, have besides their proportionate light-weakness and their chemical focus, a very moderate expansion of the evenly illuminated available picture field, comprising hardly more than 6 to 8 degrees. The small aplanats, which are used for the same purpose, require very strong diaphragms and give a picture field with little plane. The new objective, which is furnished without diaphragms, comprises an extremely large picture angle of almost  $26^\circ$ , and covers to the edge of the field with almost equal sharpness and without the least trace of chemical focus. The instrument, which I have tested, has an equivalent focal distance of about 50 mm., and forms a sharp object of nearly 4 sq. cm. The light power is quite extraordinary; for enlargements 10 to 15 times by ordinary 15-candle gaslight the exposure was 3 to 8 seconds upon bromide of silver gelatin. The instruments, whose general introduction is only to be desired, can also be executed in other sizes, as for instance from 4 to 6 inches equivalent focal distance.”

PENNY, W. G.—Eye-pieces—Physical Aberration and Distortion.

*Engl. Mech.*, XLVII. (1888) p. 215 (1 fig.).

### (3) Illuminating and other Apparatus.

Hilgendorf's Auxanograph.† — This instrument, devised by Dr. F. Hilgendorf, is a micropantograph designed to produce outline sketches (orthogonal projections) of small objects down to less than 1 mm. on an increased scale of from 2 to 10.

The four arms *Wb*, *WV*, *ZY*, *XY* (fig. 103), are supported on long

\* Dr. H. W. Vogel in 'Anthony's Photographic Bulletin,' 1888, p. 230.

† *Zeitschr. f. Instrumentenk.*, vii. (1887) pp. 290–1 (1 fig.).

vertical axes at W, X, Z, Y, above a drawing board; at  $f$  is a rod, held by drawing pins, which serves as the fixed point about which the whole instrument turns in drawing; the paper is placed under the pencil at  $b$ ; the object is at  $d$  under a lens which is carried by a diopter in ZY, and which has a cross engraved upon its upper surface. The pencil at  $b$  is moved by the hand in such a way as always to keep the centre of the cross upon the outline of the object as it appears to the eye above  $d$ . The scale of the drawing may be varied by sliding the rod  $f$  and the lens  $d$  along their bars; the points  $f d b$  are to be always in the same straight line. Between V and Z are slots corresponding to an amplification of 2,  $5/2$ , 3, 4, 6, 8, and 10 respectively, and the lens is adjusted by means of a scale along ZY having its zero point at Z. The board being set horizontal by a level, and the upper opening of the tube being adjustable, the line joining the two openings may be made vertical by a plummet, so that the line of vision is always perpendicular to the plane of the drawing. The lens is made horizontal by means of a pendulum movement about the screw which fixes the lens-holder to the tube. The lens may also be adjusted by means of a horizontal mirror placed below it, the engraved cross being made to coincide with its image seen in the mirror. When higher powers are used the object is to be raised by a support to the correct focal distance. When a large object is being drawn, the long axis at Y may be replaced by a short one; and in this case the bar XY may be prolonged beyond Y, and fitted with a long axis at its end.

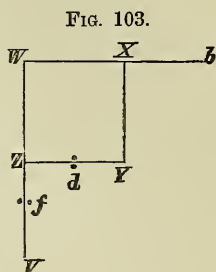

The instrument is designed "rather with a view to practical convenience than to realize with mathematical accuracy the exact reproduction of an object."

**Slide for observing Soap-bubble Films.\***—A simple means for showing soap-films by the Microscope, may, Mr. F. T. Chapman points

FIG. 104.

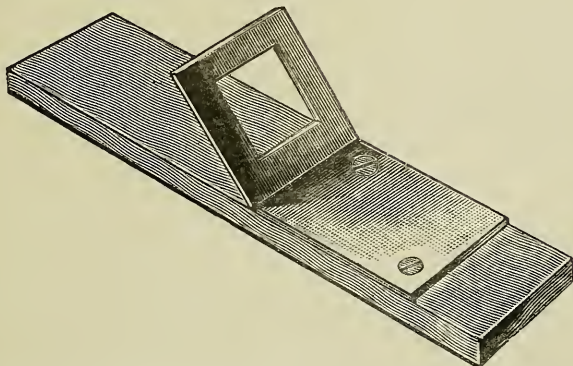

out, consist of a thin strip of wood (3 in. by 1 in.), or other material, with a metal plate secured to it. The plate should have one end

\* Read before the Washington Microscopical Society. Cf. Amer. Mon. Mier Journ., ix. (1888) pp. 81-2 (1 fig.).

bent upward from the strip at an angle of  $45^\circ$ , and have a square hole through it. The film increases in brilliancy as it grows thin. The light should be thrown on the film from above, so that the beam will be reflected up the tube of the instrument. The proper angle can readily be found by trial.

The following are some directions for making suitable soap-bubbles:—

(1) Shave Marseilles (Castille) soap and dry thoroughly in the sun or on a stove. (2) Put the dried shavings in a bottle with alcohol of exactly 80 per cent. strength (specific gravity 0.865), sufficient to form a saturated solution at  $60^\circ$  Fahr., the solution then marking  $74^\circ$  on the centesimal alcoholometer, with a density of 0.880. The solution must be made cold, as warm alcohol would dissolve too much soap, and the solution would solidify when cool.

(3) Make a mixture of glycerin and water, so as to mark  $17.1^\circ$  Baumé, or have a density of 1.35 at  $68^\circ$  Fahr. This solution can be made of equal parts of the most concentrated glycerin and water, and it is well to heat the solution in a water-bath.

(4) To make the final solution, take 100 parts, by volume, of the glycerin solution (3) to 25 parts of the soap solution (2), mix and boil to expel alcohol. When cool, pour into a graduate and add water to equal 100 volumes. Then filter several times to remove oleate of lime. Common glycerin is apt to make the solution turbid on account of the presence of gypsum and lime. A funnel with a plug of cotton makes the best filter, as the flow can be regulated by the tightness of the cotton in the funnel. Soap-bubbles, not more than 4 in. in diameter, and supported on a tripod under a bell-glass, are said to last for an hour. The preparation is suitable for Plateau's experiments with thin films, soap-bubbles, &c.

Plateau's soap-bubble solution is prepared as follows:—

Dissolve one part of Marseilles soap in 40 parts of water (rain or distilled), which may be warmed. When cool, filter through very porous filter paper and add Price's glycerin in the proportion of 11 parts of glycerin to 15 parts of the soap solution. Shake thoroughly, and allow the solution to stand for seven days where the temperature will not fall below  $67^\circ$  Fahr. Then cool to  $37^\circ$  Fahr. and filter, keeping a bottle of ice in the funnel. The first parts filtered should be refiltered, using very porous filter paper. Halbrook's brown oil silk soap, or his Gallipoli soap, and Sheering and Glatz's glycerin work very well. Long standing and decantation from sediment may take the place of the second filtration. After all the trouble, the mixture may not give very good results.

An excellent soap-bubble solution may be formed by a compound of oleate of soda and pure glycerin. Bubbles 2 feet in diameter may be blown, and bubbles have been kept under glass for 48 hours.

A good and easily prepared solution may be made by shaving 4 oz. of Marseilles, or better, of pure oil soap, and placing it in a quart of distilled or rain-water. Shake until a saturated solution is formed, and let it settle for a few hours. The solution should then be clear. If otherwise, pour off the water, and add fresh water to the same soap and try again. To the clear solution add about one-half the quantity of glycerin that is absolutely pure. The presence of the least quantity of acid in the glycerin is fatal to good results and therefore it is recom-

mended that for any soap-bubble solution the ingredients be the best and purest obtainable, and that chemically pure glycerin be used.

**Schäfer's Hot-water Circulation Stage and Swift's Regulator.**—Prof. E. A. Schäfer's hot stage (fig. 105), consists simply of a metal box with a pipe at each end; hot water entering by the lower end, and flowing away at the upper.

Messrs. Swift and Son use as a regulator for maintaining an even temperature what is practically the same apparatus as was described in

FIG. 105.

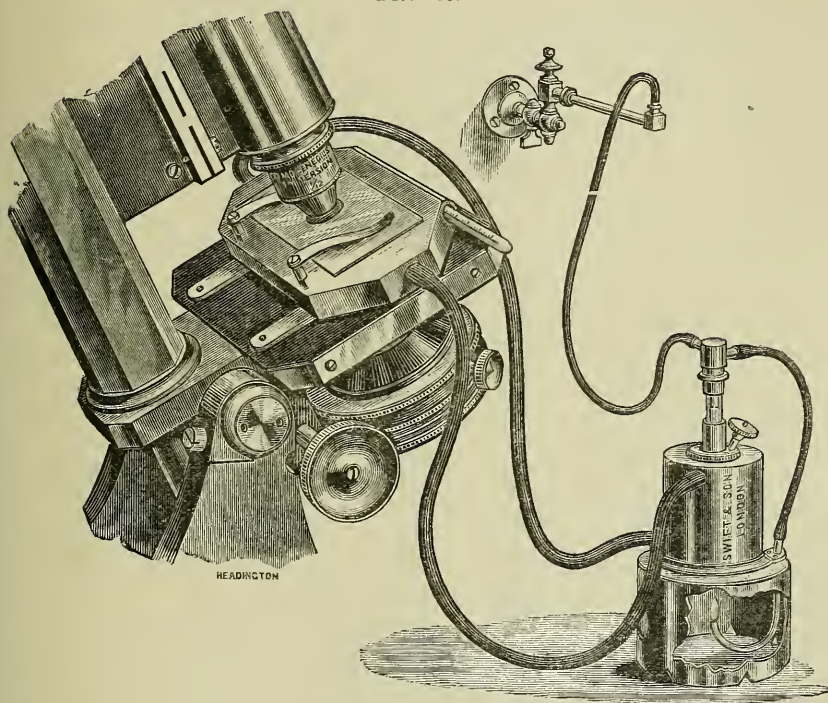

this Journal, 1887, p. 316, a pipe for the gas leading into a tube with mercury, whence it flows by another pipe to the gas-jet beneath the water reservoir, the milled head screw regulating the height of the mercury in the tube in the first instance.

**Bertrand's Refractometer.\***—In order to measure the index of refraction of pyroxene, amphibole, &c., which is  $> 1.69$  with this apparatus,† M. E. Bertrand has made the hemispherical lens of flint glass ( $n = 1.962$ ), and proposes as moistening fluid methylen iodide ( $n = 1.75$ ), the refractive index of which might possibly be increased by dissolving other substances in it.

\* Bull. Soc. Franç. Min., x. (1887) pp. 140-1.

† See this Journal, 1887, p. 469.

## SEAMAN.—Exhibition of Lamp and Vertical Illuminator.

[He said, "You may remember that some time ago I showed a vortical illuminator made by Mr. Chas. F. Asoldt of Albany. I have here a slide of his rulings, which contains 19 bands, from 5000 to 120,000 to the inch, which is no doubt a very excellent specimen of this kind of work, similar to the celebrated Nohert plates. I have no hesitation in saying that on an object of this kind, with an immersion-lens, the definition obtained by this illuminator is superior to anything I have ever seen, and that by its means the human vision may be pushed to its utmost limit."]

*Amer. Mon. Micr. Journ.*, IX. (1888) p. 97.

## (4) Photomicrography.

**Leitz's small Photomicrographic Apparatus.**—This, fig. 106, is an adaptation of several somewhat similar forms which have been already

FIG. 106.

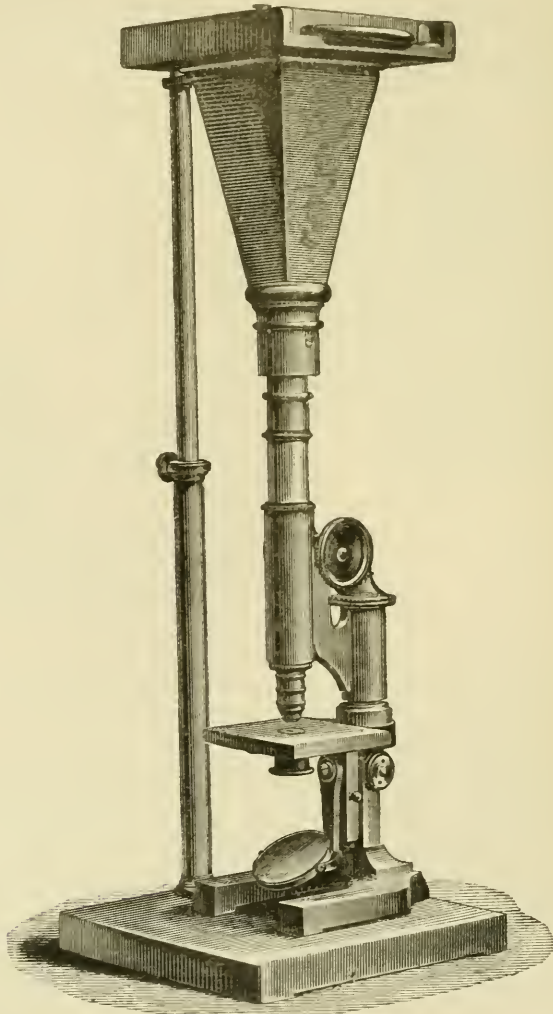

described. Its speciality consists in attaching the camera to a rod which is extensible in a socket (with a clamp screw), by which means the camera can be made to fit any Microscope, whatever its height.

**Plössl's Focusing Arrangement.**—Messrs. S. Plössl apply to their photomicrographic camera the fine-adjustment shown in fig. 107.

FIG. 107.

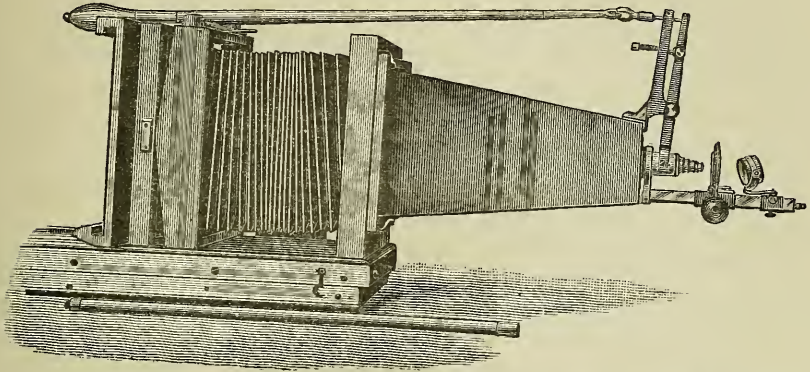

This is practically a very large form of the Jackson fine-adjustment, the lever which raises and depresses the movable nose-piece being actuated by a large rod with a "Hooke's joint," the handle of which is at the end of the camera.

It appears to us (without having practically tested the point), that the enormous leverage of the focusing rod must add greatly to the difficulty of focusing.

**Instantaneous Photomicrography.\***—Sig. S. Capranica comes to the following conclusions as the results of his experiments on instantaneous photomicrography:—

(1) Rapid photography  $1/20$  of a second, or very rapid  $1/200$  of a second, can be obtained with the photographic Microscope if very high powers and immersion lenses be used.

(2) By means of a special shutter and a particular arrangement, any number of successive negatives of the movements of an object can be obtained just as, macroscopically, the flight of birds, and the rapid movements of other animals (Marey, Maybridge, &c.), have been.

(3) By the method of successive positions, the author has succeeded in reproducing upon the same sheet the different planes of any preparation, obtaining thus a photograph unique in its entirety.

The author particularly calls the attention of microscopists to the results noticed in (2), as they are entirely new and susceptible of numerous and important applications in the study of the Infusoria and of all living micro-organisms.

KITT, T.—Ueber Mikrophotographien. (On Photomicrographs.)

*Oesterr. Monatschr. f. Tierheilk.*, 1888, No. 6, 18 pp.

MÜLLER, N. J. C.—Atlas der Holzstructur dargestellt in Mikrophotographien. (Atlas of wood structure represented in photomicrographs.)

21 pls. and 60 figs., 4to, Halle, 1888.

\* Journ. de Microgr., xii. (1888) p. 227.

- SIMMONS, W. J.—Magnification in Photomicrographs. *Sci.-Gossip*, 1888, p. 162.  
 WALMSLEY, W. H.—Photomicrography and the making of Lantern Slides.  
*Anthony's Phot. Bulletin*, XIX. (1888) pp. 231-3.

## (5) Microscopical Optics and Manipulation.

- BLACKBURN, W.—Diffraction Spectra.  
*Trans. and Ann. Rep. Manchester Micr. Soc.*, 1887, pp. 58-60.  
 CRISP, F.—Micromillimetre.  
 [Announcement of the decision of the Council and Fellows, *ante*, p. 503.]  
*Nature*, XXXVIII. (1888) p. 221.  
 NELSON, E. M.—  
 [Nomenclature of eye-pieces and objectives—Relation of aperture to power, &c.;  
 also letters by T. F. S., F. D'Agén, and A. S. Z.]  
*Engl. Mech.*, XLVII. (1888) pp. 190-1, 216.  
 ROYSTON-PIGOTT, G. W.—Microscopical Advances. XXXVII., XXXVIII.  
 [Researches in high-power definition—Attenuated lines, circles and dots.]  
*Engl. Mech.*, XLVII. (1888) pp. 293 (2 figs.), 447 (1 fig.).  
 RÜCKER, A. W.—Micro-millimetre.  
 [Reply to Mr. Crisp's letter, *supra*.] *Nature*, XXXVIII. (1888) p. 244.  
 SALOMONS, D.—Note on Depth of Focus.  
*Journ. and Trans. Phot. Soc. Gr. Britain*, XII. (1888) pp. 160-5.

## (6) Miscellaneous.

**American Microscopes.\***—Mr. C. F. Cox in his inaugural address as President of the New York Microscopical Society, said that it was "not long since some professed advocates of the popularization of science went through the form of reading us microscopists out of the general body of scientists, on the ground that we were not entitled to fellowship or encouragement because we were only 'amateurs' (that is say, lovers of science), were 'hangers on to the regular scientific army,' were 'universal gatherers,' and were 'undertaking to divide the sciences according to the tools used;' and we were spoken of contemptuously as 'delighting in a formidable and extensive deal of brass stand.' To most of these charges it was hardly necessary to put in any formal defence, for it was obvious that the animus of the attack upon us was the old-fashioned delusion that there is some kind of merit in doing scientific work with poor appliances. But another phase of this general notion has recently manifested itself in a vigorous onslaught upon American Microscopes, for which, with evident appropriateness, the vehicle selected has been the journal which three years ago promulgated the now celebrated bull of excommunication. According to the latest champion of scientific orthodoxy, who declares that he has 'seen and examined a great many different stands, and the lenses of many manufacturers,' 'it is undesirable to recommend a student to purchase any Microscope whatsoever of American manufacture,' but it is desirable 'to always counsel him to obtain, if possible, one of the German or French instruments,' which, as nearly as I can make out, conform to the common model of twenty-five or thirty years ago. The general objection to American stands seems to be that they furnish more mechanism than the particular worker who wrote the complaint happens to require for his particular work. He makes a more specific charge, however, that they have a joint in the body by means of which they *may* be tipped out of a vertical position, when the makers ought to have

\* Journ. New York Micr. Soc., iv. (1888) pp. 106-15.

known that he and his pupils never *care* to tip their Microscopes; and another specification is made of the fact that the length of the tube has not been determined solely with reference to the height of the table or the chair which this rather exacting critic commonly employs; at least this is the inference I draw from his demand that tubes should never be made longer than suits *his* convenience.

Now, I presume you find it as difficult as I do to understand why all supposed faults are laid at the doors of American manufacturers; for surely all bad Microscopes are not American, even if all American Microscopes are bad. But the unreasonable and sweeping denunciation in which this somewhat self-opinionated iconoclast indulges is only another illustration of the familiar phenomenon of blotting out all the rest of the world by holding a comparatively small object close to one's eye; for here is an acknowledged expert in histology, who is so completely absorbed in his speciality as to be entirely oblivious to, or regardless of, the instrumental needs of all other branches of microscopy. In common with others who have lately made public display of their ignorance of the vastness and variety of microscopical research, he would actually prescribe 'for one that uses the Microscope for real work' a single simple pattern which, as you may imagine, would be pretty strictly limited to the requirements of his own restricted field of investigation. Instruments which perhaps meet the demands of different classes of observers are 'constructed with a view of entrapping inexperienced purchasers.'

Unfortunately, this sort of narrow opposition to the inevitable elaboration of scientific implements is not a thing which decreases with the general increase of knowledge. It has accompanied every step in the development of the Microscope and its accessories, and I suppose it will go right on in the future; for I can hardly imagine a time when some specialist will not think it praiseworthy to condemn 'the latest improvements,' and take personal pride in pointing to the results of his own labours accomplished by the use of only the simplest mechanical aids.

Within a short time we have heard learned sermons preached upon the superiority of specimens prepared without the employment of circular cover-glasses, and, of course, without the assistance of the turntable. It was admitted that they were not very attractive to the naked eye; but then there was 'no nonsense' about them, they were intended '*for use!*' So, too, we have witnessed a later contest over the microtome. What earnest homilies we have listened to upon the superlative excellence of the German method of free-hand section-cutting, and how positively we have been assured that all mechanical section-cutters were only delusions and snares. I have to admit that some of the later developments of this accessory are rather formidable-looking engines which seem capable almost of cutting timber for commercial purposes; but I notice that the gentleman who denounces all American Microscopes as being too complicated, is himself the inventor of one of those elaborate slicing machines. Yet the automatic microtome plainly has come to stay, so have the mechanical stage, the swinging substage, and many other contrivances over which we have seen battle waged.

Shall we ever forget the terrific struggle with which the homogeneous-immersion lens was obliged to win its way to a footing in the microscopical world? Men of no small importance blocked the road, not

with drawn swords, but with drawn diagrams which most certainly proved, if they proved anything, that an angle of more than  $180^\circ$  was an optical impossibility, and that, no matter what people might *think* they saw, they at all events could not see round a corner; for, as old John Trumbull wrote,—

‘Optics sharp it needs, I ween,  
To see what is not to be seen.’

But now how perverse and prejudiced all that opposition seems, and how simple and reasonable the new system of numerical aperture is seen to be!

Before our time the fight was fought over the binocular body, the achromatic objective, and even the compound principle itself.”

The author then quotes from Hill’s ‘Essays in Natural History and Philosophy’ (1752), a passage in which the general superiority of the simple over the compound Microscope is insisted upon, and refers to an “amusing case of circumstantial mendacity, or of clever fiction,” quoted from Father Noel D’Argonne\* in that curious work attributed to Dr. John Campbell, entitled ‘Hermippus Redivivus, or the Sage’s Triumph over Old Age and the Grave,’ in which is mentioned a Microscope which not only showed the atoms of Epicurus and the subtle matter of Des Cartes, but the secret of personal sympathy and antipathy which was shown to depend on the similarity or contrariety of the perspired vapours. A recent writer † has also described “an original arrangement of lenses,” by which he has “hit upon the awful discovery of the departing soul with its astral covering!”

These matters were introduced by the author into the subject with which he was dealing, because he “cannot see anything better in under-rating the value of our mechanical appliances than in over-estimating the capabilities of our lenses.”

**Death of Mr. Webb.**—We regret to have to record the death of Mr. Webb, the well-known engraver of the Lord’s Prayer in characters so minute that the whole Bible could (in the case of one slide in our possession) be written fifty-nine times in a square inch. In this and similar feats Mr. Webb was without a rival, and his name may fitly be linked with that of Nibert as one of the great masters of the art of minute engraving with a diamond on glass.

**American Postal Microscopical Club.**

[Comments on 13th Ann. Report.]

*The Microscope*, VIII. (1888) p. 149.

**BIDWELL, W. D.—The Microscope in Medicine.**

*Amer. Mon. Micr. Journ.*, IX. (1888) pp. 108–9.

**BOWMAN, F. H.—Does Science aid Faith? II.**

[Contains illustrations drawn from the Microscope.]

*Christian World Pulpit*, 1888, May 30th, pp. 348–50.

**COUVREUR, E.—Le Microscope et ses Applications à l’étude des Végétaux et des Animaux.** (The Microscope and its applications to the study of plants and animals.)

350 pp. and 112 figs., 8vo, Paris, 1888.

**Examinations in Microscopy.**

[“The examination in microscopy passed by the graduating class of the St. Louis College of Pharmacy, and published in the ‘National Druggist,’ is

\* ‘Mélange d’histoire et de littérature, par M. de Vignoul-Marville,’ Paris, 1700.

† ‘The Hidden Way across the Threshold,’ by J. C. Street, Boston.

a model of its kind. We are certain of 51 Ph.G.'s who know something of the use of the Microscope."]

*The Microscope*, VIII. (1888) p. 156.

**Italian Microscopical Society.**

[Just formed; articles and papers are to be published in Latin, French, English, and German. Secretary, Sigr. J. Platania, 14, Via S. Giuseppe, Acireale, Sicily.]

*Sci.-Gossip*, 1888, p. 139.

**Munchausen still alive.**

[While the following is too outrageous rubbish for the pages of the Summary, it ought not to go quite unrecorded. "A weekly and much-read paper has the following bit of veracity: *The Human Blood*.—Professor Bronson (an American) states, that if a drop of human blood be subjected to examination by the hydrogen Microscope, and magnified some 20,000,000 of times, all the species of animals now existing on the earth, or that have existed during the different stages of creation for thousands of years past will be then discovered. In the blood of a healthy person all the animalcula are quiet and peaceable; but in the blood of a diseased person they are furious, raging, and preying upon each other. That man contains within himself all the principles of the universe; also, that, if a dead cat be thrown into a pool of stagnant water, and allowed to dissolve there, a drop of water taken from any part of the pool, will show as above, every species of animal of the cat kind that has ever existed on the earth, raging and destroying one another, the bodies of all the lower animals being thus made animalcula similar to themselves, and the body of man being compounded of all that is below in the scale of creation."]

*Sci.-Gossip*, 1888, p. 142.

**QUINN, E. P.—The use of the Microscope in the examination of Rock Sections by Polarized Light.**

*Trans. and Ann. Rep. Manchester Micr. Soc.*, 1887, pp. 60–1.

**Zentmayer, J., Obituary of.**

*Queen's Micr. Bulletin*, V. (1888) p. 9.

**β. Technique.\***

(1) Collecting Objects, including Culture Processes.

**Preparation of Nutritive Media.**†—Dr. E. Jacobi prepares agar, gelatin and *Fucus* as nutritive media as follows:—The test-tubes, flasks, &c., are first cleaned and stopped with cotton-wool, and then heated for 2½ hours in a Papin's digester over a gas-burner. The cotton-wool must nowhere touch the sides of the digester. The temperature inside reaches to about 150°.

(1) In making agar-agar, the ordinary agar is cut into small pieces, and (a) either 1½ litre of cold meat infusion with 15 gr. (1 per cent.) peptone, 7·5 gr. (0·5 per cent.) NaCl, and 15–22·5 gr. (1–1½ per cent.) agar, or (b) 1½ litre of water, 7·5 (0·5 per cent.) Kemmerich's meat-peptone, 15 gr. (1 per cent.) peptone, and 15–22·5 gr. agar, are boiled in a metal saucepan over the open fire until the agar is perfectly dissolved, which happens in about ¾ hour. The water lost by evaporation is replaced and the solution rendered slightly alkaline by means of carbonate or phosphate of soda. The fluid is then poured into flasks and steamed until the albuminous matters have separated out; if neutralized with sodium phosphate this happens in about 2 hours; if with carbonate of soda, the time is longer. Filtration is effected in a few minutes. A tube holding about 1½ litre, about 70 cm. long and 6 cm. in diameter, is

\* This subdivision contains (1) Collecting Objects, including Culture Processes; (2) Preparing Objects; (3) Cutting, including Imbedding and Microtomes; (4) Staining and Injecting; (5) Mounting, including slides, preservative fluids, &c.; (6) Miscellaneous.

† *Centrbl. f. Bakteriologie u. Parasitenkunde*, iii. (1888) pp. 538–40.

closed at its lower end by a layer of cotton-wool 5 cm. thick; the fluid is then poured in and the upper end closed with a caoutchouc plug, in which is an opening for a glass tube. To the glass tube is connected a rubber bellows which, when worked, compresses the air inside the tube, so that the agar soon runs out quite clear, and is then sterilized in the usual manner.

(2) For preparing gelatin,  $1\frac{1}{2}$  litre of water, 22.5 gr. ( $1\frac{1}{2}$  per cent.) Kemmerich's meat-peptone, and 45 gr. (3 per cent.) peptone, are boiled for some minutes in a metal pan over the open fire and then cooled down to  $50^{\circ}$ - $60^{\circ}$  C. In this mass are dissolved 225 gr. (15 per cent.) gelatin, and the solution neutralized with carbonate of soda. The whole mass is then shaken with the white of an egg and steamed for  $1\frac{1}{2}$  hour; the albumen and other substances are precipitated, and then filtration is done in the way described above. The water-clear gelatin is then distributed into flasks and sterilized in the usual manner.

(3) For preparing a fucus mass, the same directions as were given for agar must be followed, except that  $2\frac{1}{2}$  per cent. *Fucus crispus* is used. Before neutralization it must be strained through a cloth, as *Fucus crispus* is not so perfectly soluble as agar.

**Preparing Agar-agar.\***—Dr. E. Freudenreich prepares agar, and at the same time shortens the process in the following manner:—1 per cent. of agar is added to meat infusion, and the mixture boiled on the open fire until the agar is quite dissolved. The solution is then neutralized and afterwards reboiled until the albuminous matters are precipitated. So much of the solution as will be required to fill a flask or test-tube is then poured into a funnel with paper filter and placed in a steam sterilizer, and the temperature raised to about  $110^{\circ}$ , and in about one hour the glass vessel will have received its proper quantity of clear agar. Of course, several flasks, &c., may be got ready at the same time. When complete the vessels are plugged with cotton-wool, and in this way one sterilization is saved.

**Milk-peptone-gelatin for cultivating Pathogenic Micro-organisms.†**—Middle. M. Raskin prepares milk-peptone-gelatin by warming 1000 ccm. of new milk to  $60^{\circ}$ - $70^{\circ}$  C., and then adding 60-70 gr. of solid gelatin. When the gelatin is dissolved the solution is boiled until complete coagulation of the casein has taken place. It is then strained through a linen cloth into a wide glass vessel, in order that the fat may ascend to the surface without difficulty, and when it has settled the fat is skimmed off. When freed from the fat the mixture is heated and 1 per cent. peptone added, and then soda to neutralization. The addition of NaCl increases the nutritive value of the quite clear transparent gelatin.

The preparation of milk-peptone-agar is somewhat more complicated. To 1000 ccm. of milk are added 50 ccm. gelatin and five to seven pieces of agar cut up small. After standing for fourteen hours at the ordinary room temperature, the mixture is boiled for three hours until the casein is coagulated; the rest of the procedure is as in the foregoing preparation.

In preparing milk-casein-gelatin and milk-casein-agar, 150 ccm. of

\* Centralbl. f. Bakteriologie u. Parasitenk., iii. (1888) pp. 797-8.

† Petersburger Med. Wochenschrift, 1887, pp. 20-43. Cf. Centralbl. f. Bakteriologie u. Parasitenk., iii. (1888) pp. 568-9.

pure 8 per cent. casein solution, quite free from fat, are mixed with 350 ccm. of a filtered mixture of whey and 12 per cent. gelatin or 1.75 per cent. agar. The whole mass is then heated to 60° C. and transferred to test-tubes.

To prepare milk-albumen-gelatin and milk-albumen-agar the peptone is replaced by a saturated solution of sodium albuminate.

With the foregoing media cultivation experiments were made with *Bacillus mallei*, *B. Typh. abdom.*, comma bacillus, *B. tussis convuls.*

The authoress states that glanders-bacillus develops luxuriantly on the milk-peptone media at 37°–38° C. On the second day after inoculation a thick dull-white crust forms on the agar surface. In three to four days the colour is amber to orange, the deeper layers being brownish-red. The authoress is disposed to regard these milk media as being very favourable to the growth of certain microbes which on others do not betray any special characteristics.

**Vessel for the Culture of Low Organisms.\***—Herr N. W. Diakonow has constructed an apparatus, of which the following is a description, for the culture of low organisms, the special object being to prevent the intrusion of bacteria and other foreign bodies.

The apparatus (fig. 108) consists of a vessel composed of two parts, a bulb A provided with two necks, and a burette B, connected with one another by a caoutchouc tube in such a way that the burette moves easily from side to side. To the lower end of the burette, which must be supplied with a glass tube of equal diameter with the upper portion of the neck of the bulb, is fused a short and narrow glass tube running out into a capillary prolongation. The upper part of the burette is again connected with a narrow glass tube by means of a caoutchouc tube shut off by a stop-cock, the glass tube being widened at its upper end for the reception of a wad. The size of the entire apparatus may be adapted to the requirements of the experiments; for fungi cultivated on a nutrient solution only 10–15 ccm. in quantity, the height need not exceed 15–17 cm.; the bulb then having a capacity of about 70–80 and the burette of about 3–5 ccm. It is especially needful that the apparatus should be so constructed that, after the sterilizing of the nutrient solution, no foreign organisms can enter it.

In using the apparatus, the burette and the solution to be introduced into it must first of all be sterilized. For this purpose the whole burette with its capillary prolongation is dipped into boiling water, which is sucked up to the upper bulb containing the wad; this process is repeated several times. The

FIG. 108.

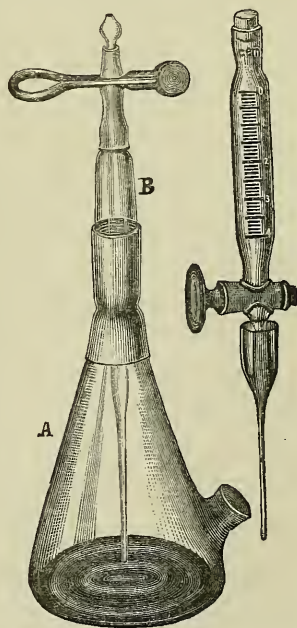

\* Ber. Deutsch. Bot. Gesell., vi. (1888) pp. 52–4 (1 fig.).

burette is then immediately immersed in the hot solution, filled with it, and placed in connection with the bulb A; and the nutrient solution in A is then further sterilized by long boiling. After the sterilized nutrient solution has become cold, it is neutralized from the burette until the red colour has almost entirely disappeared; and the germs are then introduced into A through the lower neck. The exchange of gases between the interior of the apparatus and the external air can take place only through this neck, which is stopped by a wad. In experiments where quantitative estimation is required, the burette B may be replaced by another, represented at the right of fig. 108.

PUTEREN, M. D. v.—Ueber Bereitung fester Nahrungsgemische für Mikroben aus der Milch. (On the preparation of solid nutrient media for microbes from milk.) *Wratsch*, 1888, pp. 281-4 (Russian).

## (2) Preparing Objects.

**Preservation of Parts and Organs of Animals.\***—Dr. A. Mischold praises highly Giacomini's method of preserving organs, both normal and pathological. The parts retain their normal size and appearance and remain perfectly supple, so that they can be placed in any position.

With time the volume diminishes about 1/20, but the weight is increased by 150-200 grm. in consequence of the impregnation. The procedure is as follows:—The organ, for example a whole brain, is first of all injected through an artery with a saturated filtered solution of chloride of zinc, and then placed in a solution of this until the brain has sunk down to the bottom of the vessel.

During this time (about eight days) it is advisable to strip off the membranes, otherwise rusty patches appear along the course of the vessels. The brain is then placed in strong spirit for ten or twelve days, or until it has sunk to the bottom. The spirit must be changed two or three times. It is next placed in pure glycerin, to which 1 per cent. of carbolic acid is added, until it again sinks to the bottom. The preparation should be turned over several times, and when saturated with glycerin should be exposed to the air for several days upon a layer of cotton-wool to dry. It is finally coated over with a thin layer of a solution of gummi elasticum or guttapercha in benzin. For preparations other than brains an 8 per cent. zinc chloride solution is advised, and for still smaller ones a solution half as strong.

**Two new Methods for preparing Nerve-cells.†**—(1) Instantaneous preparation.—Prof. L. v. Thanhoffer takes a small piece from the grey substance and presses it between two cover-glasses, so that when drawn apart there adheres to both a thin layer of nervous matter. The cover-glass is then heated in the flame of a spirit-lamp or of a gas-jet until the nervous layer has assumed a blackish-brown colour, and a distinct smell of burning is perceptible. The preparation is then mounted in xylol-dammar. The nerve-cells and the nuclei of the neuroglia-cells, as well as the blood-vessels and their nuclei, are very clearly seen in such preparations.

(2) Double cover-glass preparation.—To produce permanent and

\* Morskoi Sbornik, Supplement, 1886, pp. 207-9. Cf. *Zeitschr. f. Wiss. Mikr.*, iv. (1887) pp. 375-6

† *Zeitschr. f. Wiss. Mikr.*, iv. (1887) pp. 467-9.

stained preparations of nerve-tissue, the author squeezes a piece of grey substance about the size of a hemp-seed between two cover-glasses. The double cover is then placed for 15 days in picocarmine, four days in absolute alcohol, and then for two days in oil of cloves and xylol apiece, and lastly fixed up with xylol dammar, which is poured over the cover-glasses. After the dammar varnish is dried the surface of the cover-glass is cleansed of the resin.

**New Method for the Microscopical Study of the Blood.\***—The methods hitherto employed in preparing the blood for microscopical examination have aimed either at the production of fresh or of dry preparations. Preparations of the first class are not permanent, and those of the second class never exhibit the morphological elements intact. Dr. D. Biondi has worked out a method which combines the advantages, and is free from the defects, of previous methods. The problem was to find the means of perfect fixation, preservation, imbedding, and mounting—in other words, a method by which the blood could be treated as a solid tissue. The method is equally useful in the study of other organic fluids, and has been successfully employed in tracing the changes that take place in the maturation of the spermatozoa. It may doubtless be used to advantage in the study of Infusoria, as suggested by Biondi.

The point of chief interest in Biondi's method is the use of agar as an imbedding material. Agar is a vegetable gelatin obtained from *Gracilaria lichenoides* and *Gigartina speciosa*, and has already been successfully employed for some time by Koch in bacteriological investigations. Among the different sorts of agar, the columnar form (Säulen-Agar) is considered the best. A perfectly transparent solution is required, in the preparation of which great care must be taken. This may be accomplished in the following manner:—Place two parts of agar in 100 parts of distilled water, leaving it to soften for twenty-four hours at the ordinary room temperature; then heat to boiling on the sand-bath until the agar is all dissolved. The evaporation of the water may be checked by closing the flask with a cork provided with a long glass tube. Add carbonate of sodium to the point of weak alkaline reaction, and boil for an hour in a steam apparatus. Pour the solution into long slender test-tubes, and leave from 12–24 hours at a temperature of 50° to 60° C. The solution separates into two layers, the upper of which is quite clear, and this layer alone can be used for imbedding purposes. But clarification must be carried still farther before it is fit for use. The clear portion of the solution is next to be heated to about 40°, white of egg added, the mixture shaken up several times in the course of ten minutes, boiled for an hour in the steam apparatus, and then filtered. The reaction should then be tested, and, if necessary, carbonate of sodium added until the solution is neutralized. Exact neutralization is necessary, in view of the staining fluid to be employed.]

It is important that the mass should be kept sterile up to the moment of using, as otherwise a large number of micro-organisms may develop in it and render it worthless for the finer uses. It is advisable, therefore, to keep the mass in test-tubes, limiting the quantity placed in each to the probable requirements of a single imbedding operation. For a single preparation of the blood five cmm. of the mass is sufficient. The

\* Arch. f. Mikr. Anat., xxxi. (1887) p. 103. Cf. Amer. Natural., xxii. (1888) pp. 379–81.

test-tubes should be cleansed with hydrochloric acid and then washed with distilled water. After receiving the agar solution, the tubes are closed with cotton, and then sterilized in the steam apparatus for half an hour daily on three successive days.

As the preparation of the agar mass is somewhat complicated, much time and trouble may be saved by turning this work over to some apothecary.

The best medium of fixation for the elements of blood is a 2 per cent. solution of osmic acid. If a drop of blood from the frog be examined in this medium under the Microscope, it will be seen that both the red and the white corpuscles are perfectly preserved in form and structure. The red corpuscles become a little paler than in the living condition, and are slightly browned. The corpuscles of mammalian blood are isolated and seen to greater advantage than in any other medium of fixation. As it is important that the acid should be perfectly clear and free from all impurities, it is well to filter before using.

*Method of Procedure.*—(1) By the aid of a clean pipette, take a little blood from the heart of a frog, and allow two drops to fall into five ccm. of osmic acid (2 per cent.). Shake a little—the sooner the better—in order to separate the elements and scatter them through the whole body of the acid. After standing a while, the blood-corpuscles will be found at the bottom of the tube, the deeper layer being formed mainly of red corpuscles, which sink first by virtue of their greater specific gravity. Exposure, 1–24 hours.

(2) The process of fixation completed, four to five drops of the mixture of blood and osmic acid are allowed to fall from a pipette into the melted agar, which is kept fluid at a temperature of 35°–37° C. By rotating the test-tube the blood-corpuscles are distributed through the agar, and then the whole is poured into a paper box, as in the ordinary paraffin method of imbedding. Within a few minutes the mass stiffens and may be removed from the box to 85 per cent. alcohol for hardening. In three to six days the mass is hard enough for sectioning, and may be inclosed in elder-pith and cut with the microtome.

If finer sections are required than can be obtained in this way, the agar block may be imbedded in paraffin in the following manner:—The block is to be transferred from the 85 per cent. alcohol to bergamot oil (24 hours), then direct to soft paraffin kept at a temperature of 45° C. After one to two hours, the imbedding process may be completed in the usual way. As the agar is saturated with paraffin, very fine sections may be obtained; and these may be freed from paraffin with the usual solvents, and then stained.

(3) Sections thus prepared may be safely treated with nearly all staining media. Methyl-green, methyl-blue, fuchsin, safranin, &c., give the most reliable results. The agar itself is stained only by the most intense anilin dyes (e.g. gentian-violet), but in such cases it loses its colour quickly in alcohol, or in any other decolorizing fluid.

(4) Sections may be clarified, preparatory to mounting, in balsam or dammar, in clove oil, organum oil, bergamot oil, creosote, &c. Xylol alone should not be used as it causes the sections to curl.

**Preparation and Staining of the Spinal Cord.\***—Prof. L. Ranvier, who has been making observations on the transformation of nerves with

\* Journ. de Microgr., xii. (1888) pp. 142-4.

Schwann's sheath to nerves without the sheath at the point of union of the anterior and posterior roots with the spinal cord, examined transverse sections of the cord in the following manner:—The dorsal region of a calf was chosen because the direction of the roots are more perpendicular to the axis of the cord than in other parts. Segments 1 to  $1\frac{1}{2}$  cm., with the corresponding roots, were placed in a solution of bichromate of ammonia, renewed two or three times during the course of a year. It requires quite a year to harden cord in bichromate of ammonia, but the process may be hastened by using successively bichromate of ammonia and chromic acid, according to Deiter's method. Sections were then made with an ordinary microtome perpendicular to the axis of the cord, and afterwards deeply stained with picrocarminate of ammonia. The sections having remained in 0.1 per cent. picrocarminate of ammonia are too deeply stained, and the colour must be removed with formic acid. This acid is of the usual strength and dissolves part of the carmine, leaving the sections a rose colour.

The decolorizing action is extremely valuable, inasmuch as it is very slow, and acts unequally on certain elements which retain carmine more than others. The formula for the formic acid solution is equal parts of ordinary formic acid and alcohol at  $36^{\circ}$ . In twenty-four hours the sections are sufficiently decolorized; they are then placed in absolute alcohol, cleared up in oil of cloves, and mounted in balsam or dammar.

All the nuclei of the neuroglia are admirably distinct, but the fibres are usually quite decolorized. The axis-cylinders are rose, and not red, but less decolorized than the neuroglia fibres. The neuroglia nuclei are able to withstand a prolonged action of the formic acid and spirit mixture, and their greater abundance in the grey matter than in the white matter of the cord is strikingly shown. The neuroglia nuclei may also be stained with purpurin or with Boehm's hæmatoxylin, which, from lapse of time, has become brownish. As this stains all the elements, everything but the neuroglia nuclei must be decolorized by means of acetic acid diluted with an equal volume of water or of spirit. A better result can be obtained from a logwood solution made from the deposit from Boehm's hæmatoxylin. This deposit is washed with distilled water and dissolved in a 1 per cent. aqueous solution of alum by the aid of heat, and then filtered. This solution only stains the neuroglia, the axis-cylinders and nerve-cells remaining quite uncoloured.

#### Demonstrating the Canalicular Prolongations of Bone-corpuscles.\*

—Sig. G. Chiarugi in attempting to solve the problem of the existence of protoplasmic prolongations of bone-cells in the primitive canaliculi, answers the question partly on theoretical grounds, for thereby the formation of the canaliculi is explained, and partly on practical, since they have already been demonstrated in the tooth. The author employed the following method.

Small pieces of fresh bone were decalcified in picro-nitric acid diluted with two parts of distilled water. These were then transferred to spirit, at first dilute, but afterwards gradually concentrated. The sections were stained for some minutes in a one per cent. watery solution of eosin, and then treated with a 3-4 per thousand solution of hydrate of potash until the colour was no longer altered. In this way the

\* Bollet. Soc. tra i Cult. Sci. Med. Siena, 1886, Fasc. viii. and ix. Cf. Zeitschr. f. Wiss. Mikr., iv. (1887) p. 490.

ground substance was unstained, while the cell elements and their prolongations remained of a bright red hue. This staining was fixed by immersing the sections for some hours in a one per cent. solution of alum. They were then examined, and mounted in the alum solution, which must be sterilized. The prolongations of adjacent cells were found to anastomose.

**Preparing Mammalian Ovaries.\***—From his investigation on the ovaries of mammalia Prof. G. Paladino finds that these organs are the seat of a continuous movement of destruction and renovation, and further, that in the formation of the ovules, the regeneration of the parenchyma, the development of the follicles, and in the production of the corpora lutea, karyokinesis occurs freely.

For hardening the ovaries the author used a 2-4 per cent. bichromate of potash solution, Müller's fluid, 1/2 to 1 per cent. osmic acid, saturated aqueous solution of sublimate, 2 per cent. chromic acid, and also Flemming's chrom-osmium acetic acid. The staining seems to have been effected entirely with picro-carminate of ammonia, of which two solutions were used, a 1 and 2 per cent. The pieces were placed in these solutions for a short time only, and then transferred to very dilute solution of picric acid. The pieces were always completely freed from the hardening fluids, and rendered neutral as the neutral reaction is indispensable for properly staining the nucleus.

**Preparing and Staining Annelida.†**—M. É. Jourdan found that 90° alcohol and picric acid gave very bad results in examination of Annelida; the tissues being crumpled and their elements unrecognizable. From bichromate of ammonia in 2 per cent. solution, sublimate in 5 per cent., or a saturated solution and Lang's fluid, beautiful preparations were obtained. One per cent. solution of osmic acid was found to give excellent results for examining antennæ and other delicate organs. After fixation in the above-mentioned fluids, the preparations were hardened in spirit. The objects were stained with carmine solution, principally with Grenacher's alum-carminic, and were imbedded in celloidin or in paraffin. The sections, which were stuck on by Schällibaum's method, were, for studying gland-cells, stained with hæmatoxylin cosin and with Hoffmann's green.

**Preparing Polygordius.‡**—Dr. J. Fraipont hardens the entire animal in 1 per cent osmic acid, washes with water, stains with ammoniacal picrocarminic, and after treating with alcohol and turpentine oil mounts in balsam.

Macerated specimens are prepared in 40 per cent. spirit for 36 to 48 hours, or still better in chromic acid 1/10000 for 24 hours. Besides employing the usual methods for macerated specimens, the author found it also advisable to squeeze half macerated parts between cover-glass and slide, by which the separated parts and their relation to one another were recognizable. Living animals treated with 1 per cent. gold chloride and citric acid, and afterwards teased out, is not a very easy method, but sometimes gives very instructive pictures. The macerated parts can be

\* 'Ulteriore ricerche sulla distruzione e rinnovamento continuo del parenchyma ovarico nei mammiferi: nuove contribuzioni alla morfologia e fisiologia dell'ovaja.' Svo, Naples, 1887, 230 pp. (9 pls.). Cf. Journ. de Microgr., xii. (1888) pp. 223-6.

† Ann. Sci. Nat. (Zool.), ii. (1887) pp. 239-304 (5 pls.).

‡ Fauna u. Flora d. Golfes von Neapel, xiv. (1887) 125 pp. (16 pls. and 1 fig.).

stained with borax-carmin, hæmatoxylin or ammoniacal picrocarmine, and mounted in glycerin or balsam. In order to kill the animals without contraction, so that they may be suitable for sectioning, the author recommends benumbing them by pouring spirit into sea water and then hardening, or to pour a hot and strong solution of sublimate over them. Hot sublimate, however, alters the tissues somewhat, especially the epidermis, but even by the first mentioned method the epidermis, and also the central nervous system, are not quite satisfactory. For hardening, the author used strong spirit, osmic acid, picro-sulphuric acid, chromic acid, cold sublimate, and then treated the animals with the foregoing fluids or with acetic acid, absolute alcohol, 1 per cent. gold chloride, and a mixture of 1 per cent. osmic acid and of chromic acid 2/1000. For staining, picrocarmine and borax-carmin gave the best results. The former colours badly after chromic acid or sublimate, but after being allowed to act for 24 hours, the hue may be increased by the aid of borax-carmin. Hæmatoxylin and the anilins were tried on the chromic acid specimens.

**Zacharias' Method of Preparing the Eggs of *Ascaris megalocephala*.**\*—Dr. O. Zacharias has discovered an acid mixture which overcomes the resistance of the egg membrane and fixes the egg completely within 25 to 30 minutes. The mixture consist of—alcohol 90 to 100 per cent., 80 ccm.; glacial acetic acid, 20 ccm.; osmic acid 1 per cent, 20 to 30 drops. A little glycerin or chloroform increases the clarifying power of the mixture. Van Beneden employed a stronger mixture, consisting of absolute alcohol and acetic acid in equal parts, without the addition of osmic acid.

(1) *Ascaris* females obtained from the living horse by means of arsenic pills, are placed between two sheets of cotton which have been slightly moistened in a 3 per cent. salt solution, then covered with a bell-glass and exposed one to three hours to an incubation temperature of 25° C. This procedure brings the polar globules to development in the younger eggs, and forces the cleavage in the older eggs.

(2) After an hour's incubation it is well to preserve a part of the material at disposal. The genital sacs are laid bare by a longitudinal slit in the body-wall opposite the sexual aperture; the vagina is then cut free from the body, the alimentary tract lying between the two sacs is carefully removed, and the ovarian portions of the sacs are cut off, leaving the uterine portions with their contents for preservation. The anterior ends of the uteri contain eggs in all stages of maturation and fecundation; the posterior ends contain eggs already beginning to cleave. The killing and hardening process should vary considerably for these different stages.

(3) It is advisable, therefore, to cut each uterus into thirds, and to expose the anterior third to the action of the acid mixture only 5 to 7 minutes, and the posterior third at least 25 minutes. After fixation the anterior and middle thirds are transferred to 30 per cent. alcohol, and after a few hours to 50 per cent. alcohol, in which they may be kept for a long time. Eggs in process of cleavage—found in the posterior third—should be removed to absolute alcohol the moment they begin to show a light brown staining. After two or three hours they are to be transferred to 70 per cent. alcohol for preservation. If the acid mixture be

\* Anat. Anzeig., iii. (1888) p. 24. Cf. Amer. Naturalist, xxii. (1888) pp. 277-9.

heated to about 24° C., the posterior third of the uterus will require an exposure of only 10 to 15 minutes.

(4) Schneider's acid carmine is an excellent staining agent. It is prepared as follows:—Glacial acetic acid is diluted with distilled water to about 50 per cent., then as much pulverized carmine is added to the boiling acid as will dissolve. After filtering until the fluid becomes clear, a little rectified wood-vinegar is added (one drop *A. pyrolignosum* to 10 ccm. of the carmine solution) for the purpose of strengthening the clarifying power of the mixture. The younger stages may be left in the dye 3 to 4 hours, the older stages 8 to 10.

Beautiful views of the karyokinetic figures are thus obtained, but they are not permanent; after 3 or 4 hours they begin to lose in distinctness. Grenacher's alcohol carmine gives more durable preparations. Eggs thus stained may be improved by treatment with methyl-green (2 per cent.) to which have been added a few drops of glycerin. The spindle-fibres of the first and second amphiasters may be most successfully stained with "Modebraun" in very dilute aqueous solution. Preparations are mounted in two-thirds glycerin.

**Boveri's Method of Preparing the Eggs of *Ascaris megalocephala*.**\*—The following is Prof. T. Boveri's method:—

(1) The egg-sacs are plunged for a few seconds in boiling absolute alcohol which contains 1 per cent. glacial acetic acid. The eggs are thus killed instantly, and at the same time the egg-membrane is rendered penetrable to the reagents. The alcohol is allowed to cool gradually, and after a few hours the eggs are transferred to pure alcohol, coloured, and examined in glycerin or clove oil. This method shows the achromatic spindles and the chromatic equatorial plates, but not a trace of protoplasmic asters.

(2) The following mixture was used cold, with excellent results. A saturated solution of picric acid is diluted with twice its volume of water, and then 1 per cent. glacial acetic acid is added. The egg-sacs are left at least twenty-four hours in this mixture, then washed in 70 per cent. alcohol, stained in Grenacher's alcoholic borax-carmine (24 hours), transferred to 70 per cent. alcohol plus 1 per cent. hydrochloric acid (24 hours), and finally placed in pure alcohol.

For examination, glycerin is preferred to clove oil. If the egg-sacs are removed from alcohol to a mixture of glycerin (1 part) and absolute alcohol (3 parts), and then allowed to stand until the alcohol has evaporated, the eggs do not shrink. It will be found, however, that the eggs are not all equally well preserved with the cold mixture, owing probably to individual differences in the constitution of the membranes, some being more, others less permeable to the fixing reagent.

**Isolating Foraminifera.**†—Herr C. C. Keller states that Foraminifera can be obtained from marl in a very short time and in a very clean condition in the following manner. The marl is first reduced by means of highly concentrated Glauber's salts. When the pulverization has proceeded sufficiently, the sulphate of soda is washed out and the residue poured into a glass vessel in which there is a little water. The vessel is then filled up with carbonic acid water, and then placed in some warm spot or is warmed in a water-bath, its contents being carefully stirred up

\* Jenaisch. Zeitschr. f. Naturwiss., xxi. (1887) p. 432. Cf. Amer. Naturalist, xxii. (1888) pp. 381-2.

† Zeitschr. f. Wiss. Mikr., iv. (1887) pp. 474-5.

from time to time with a glass rod. The carbonic acid then bubbles up and escapes, and at the same time numerous Foraminifera collect on the surface. The explanation of this is simple. Small bubbles of the gas, owing to the heat, are developed and become entangled in the shells of the Foraminifera, and the latter are raised to the surface. The Foraminifera may then be skimmed off with the sieve used for diatoms.

Permanent preparations are made by placing the Foraminifera thus obtained in absolute alcohol in order to expel the air. They are then cleared up in oil of cloves or xylol, and mounted in Canada balsam.

**Preparing Sphærozoa.\***—For examining living Sphærozoa, Dr. K. Brandt recommends the use of a polarizing apparatus and also staining the organisms while alive. He points out that while 0·1 per cent. osmic acid fixes well, its value is discounted by the great blackening it causes, especially of the pseudopodia. The author notes also that all Sphærozoa are not equally susceptible to the action of the same reagent. (1) For *Collozoum inerme*, *C. pelagicum*, *C. fulvum*, *Sphærozoum punctatum*, *S. acuferum*, and *S. neapolitanum*, the most advantageous is a tincture of iodine (1 part 70 per cent. spirit; 1 part sea water; and so much tincture of iodine as will impart a distinctly yellow colour to the mixture). The tube in which the animals are killed is very gently shaken, and after 15–30 minutes its contents are washed with water to remove the sea salt, and then the colonies are removed to spirit of 30, 50, and 70 per cent. successively. (2) *Myxosphæra cærulea*, *Colloosphæra Huxleyi*, and *Aerosphæra spinosa* are well fixed in 0·5 to 1·0 per cent. chromic acid. After having been well washed they are transferred to 30, 50, and 70 per cent. spirits. By the iodine tincture the jelly of the species last mentioned is either dissolved or completely altered in form, while those mentioned under number (1) with the exception of *S. acuferum*, lose their jelly by the action of chromic acid, or at least their shape is damaged. (3) Strong solutions of picric acid (and picro-sulphuric acid too) behave like weak solutions of chromic acid. The species given under (2) retain some connection, but in the others the jelly is dissolved. (4) Hydrofluoric acid fixes the plasma well. (5) A 5 to 15 per cent. solution of sublimate in sea water retains the shape of *C. pelagicum*, *S. punctatum*, *S. neapolitanum* well (after acting 15–30 minutes they are well washed in sea water, then in sweet water; afterwards alcohols 30, 50, 70 per cent.). The most useful stain was found to be a watery solution of hæmatoxylin, but for *Colloosphæra Huxleyi* Grenacher's alcohol carmine. Besides these were used dahlia, the other carmine solutions of Grenacher, and Mayer's alcoholic cochineal solution.

**Preparation and Mounting of Ferns.†**—Mr. J. D. King remarks that the selection of the fern is all-important. It should be of robust growth and free from dirt. If not fully ripe the spores will be shrunken, if over ripe, absent. Have ready wide-mouthed bottles, to hold about an ounce, and filled with a mixture of equal parts of spirit and water. In this place the selected pinnæ.

If the pinnæ are to be kept for some time, add one-fourth part spirit, put only one kind in a bottle, avoid shaking the bottles, and handle the material with forceps without touching the sori.

For bleaching, the following mixture is successful :—Dry chloride of

\* Fauna u. Flora d. Golfes v. Neapel, xiii. (1885) 276 pp. (8 pls.).

† The Microscope, viii. (1888) pp. 78–81.

lime, 2 oz.; common soda, 3 oz.; water, 2 pints. Mix the chloride of lime with half the water, and the soda with the other half, then mix the two solutions and let settle in a well-corked bottle; pour off the clear liquid for use, and keep in stoppered bottles.

Pour the spirit and water from the fern and replace it with the bleaching fluid, and put in a strong light if you wish to hasten the process. Look at them often, and when there is no longer any appearance of chlorophyll in the sporangia or in the leaf, the bleaching has gone far enough. It is not always safe to wait for a stout mid-vein to become perfectly clear, for a very little over-bleaching may injure or ruin the fern. In some cases, however, it may be necessary to change the bleaching fluid two or three times.

When the bleaching is completed, remove to a liberal supply of soft water and change frequently until no trace of chlorine remains, for if the chlorine be not quite removed the staining will be a failure. Then harden the material in alcohol.

For staining epidermal structure the author advises alum-carmine and methyl-green in the proportion of one drop of methyl-green to ten drops of alum-carmine. The time required is variable. The spores and cases stain green and the leaf red; sometimes the larger veins also take on the green. If stained too long the red will supplant the green. Transfer to at least two ounces of water and soak for three or more hours to remove the alum.

For thick-leaved ferns, and for showing the fibro-vascular system and sporangia, the following procedure will be found more satisfactory: To forty drops of borax-carmine add one drop of methyl-green. The time required is longer than with alum-carmine. Then soak in water as before. A saturated solution of ammonia acetate used as a mordant will heighten the colour a trifle.

The best medium for mounting is glycerin jelly made after Kaiser's formula, with additional gelatin to give it hardness. First transfer to a mixture of equal parts of glycerin and alcohol. Then heat the glycerin jelly in a water-bath, keeping hot while using to prevent air-bubbles. With a glass rod place a few drops on the slide with or without a cell; a cell makes a better finish. Place the ferns in the glycerin jelly, add a few drops, and pour off to get rid of the alcohol and glycerin, replace what is poured off and examine with a dissecting Microscope for air-bubbles, which must be removed before the cover is applied. Breathe on the cover and apply a drop or two of hot glycerin jelly, then breathe on the slide and impose the cover.

Another way is to let the glycerin jelly harden on the slide with the fern on it and afterwards apply some hot jelly to the surface before putting on the cover. Wood sections may be stained and mounted in the foregoing manner.

**Application of Lactic Acid to the Examination of Algæ.\***—Herr G. Lagerheim recommends the use of lactic acid for restoring the turgidity to dry algæ. The acid is used in a concentrated semi-fluid form. The dry alga is first softened in water, and then placed in small pieces in a few drops of the acid on a glass slide, and heated until small bubbles make their appearance in the acid. The alga must be prevented from becoming too fluid and flowing away by heaping up with a knife. After

\* Hedwigia, xxvii. (1888) pp. 58-9.

being heated for a sufficiently long time, the cover-glass is placed on, and the alga, which was previously dry and shrunk, is now found to have swollen up to its natural form. The cell-contents are at least partially dissolved or clarified if the preparation has been boiled sufficiently long, a point of great importance, especially in the examination of desmids.

**Tempère's Preparations of Diatoms.\***—M. J. Tempère is preparing series of all the known genera of diatoms. Each series will comprise twenty-five preparations, and each preparation will contain one to three species or varieties. The first series has recently appeared.

**FREEBORN, G. C.**—Notices of new Methods. III., IV.

[Sublimate as a hardening medium for the brain (Diomidoff). New methods of preparing nerve-cells (Thanhoffer). Neutral anilin staining fluid (Babes). Safranin solution with anilin oil (Babes).

*Amer. Mon. Micr. Journ.*, IX. (1888) pp. 84, 111–2.

**LUGGER, O.**—A new Method of Preserving transparent Aquatic Insects for the Microscope.

*Proc. Entom. Soc. Washington*, I. (1888) pp. 101–2.

**MANTON, W. P.**—Rudiments of Practical Embryology. III.

[Preparation of the Embryo. Hardening.]

*The Microscope*, VIII. (1888) pp. 144–5.

**PELLETAN, J.**—Les Diatomées, histoire naturelle, préparation, classification et description des principales espèces, avec une introduction à l'étude des diatomées par M. J. Deby et un chapitre sur la classification des diatomées par M. Paul Petit. (The Diatomaceæ, natural history, preparation, classification and description of the principal species, with an introduction on the study of the Diatomaceæ by M. J. Deby, and a chapter on classification by M. Paul Petit.)

[Contains chapters on collecting, preparing and mounting.]

vol. i., 350 pp., 5 pls. and 250 figs., 8vo, Paris, 1888.

### (3) Cutting, including Imbedding.

**Collodion for Imbedding in Embryology.**†—In a note appended to a paper on "Collodion in the Technique of Embryology," Prof. M. Duval states that celloidin has no advantage over collodion; with thick collodion the same hard and resisting mass is produced, and this is always quite transparent, which is not the case with celloidin.

The method given for imbedding in collodion is as follows:—When the piece is removed from spirit after having been hardened, it is placed for some short time in a mixture of alcohol and ether (1 spirit, 10 ether). It is then placed in a solution of pure collodion for 10 minutes to 24 hours, according to size, after which it is immersed in a solution of collodion of a syrupy or pasty consistence, according to the degree of hardness required for the imbedding mass. On removal the mass is exposed to the air for not more than a minute, and it is then plunged into alcohol of 36°; the vessel containing the spirit is left open. In 6 to 10 hours the collodion is sufficiently solidified, and transparent as glass. The mass is then stuck on a piece of elder-pith with collodion, and fixed then in any position for cutting sections, which are made with a wet knife. Under certain circumstances, as, for example, when it is desired to obtain sections of batrachian ova, which are extremely friable, it is necessary to smear the surface of every section with collodion, in order to prevent the sections breaking up or evacuating their contents. The collodion for this purpose is made very thin, and a few minutes after it

\* Journ. de Microgr., xii. (1888) pp. 226–7.

† Ibid., pp. 197–204.

is laid on the surface of the section is washed with spirit. In practice this does not involve any waste of time. These collodion sections may be mounted in glycerin or in balsam, in which latter case the author proceeds in two ways. First, when he deals with sections of the blastoderm with an embryo up to the sixth day; secondly, when the embryo is larger and exceeds six days.

(1) The embryos are hardened, stained, and kept in some provisional medium. When required for sections they are passed through 36° spirit, absolute alcohol, the mixture of spirit and ether, very thin collodion, and lastly the thick collodion. A piece of elder-pith cut straight is washed with ether and then immersed in the thick collodion wherein is the blastodermic disc. The latter is then placed on the pith in the desired position and then carefully withdrawn, and after being allowed to dry in the air for a minute or two is immersed in absolute alcohol for at least 24 hours. The sections are then made, with or without brushing the surface each time with collodion, and are swept into water, from which they are easily placed upon the slide in the proper order. The sections are then dehydrated completely, and this done, the cover-glass is imposed. Clarifying is then effected by running benzine under the cover-glass, and when this is complete the section is mounted in balsam dissolved in benzine. The benzine and the benzine-balsam are run under the cover-glass, and their entrance facilitated by drawing out the fluid at the opposite side with filter-paper. The benzine used is that known as benzine Collas.

(2) If the embryo be too large to be stained *en masse*, the section is stained on the slide; moreover, the largeness of the embryo necessitates special care in the imbedding. They must be inclosed in a block of collodion, and the hardening of a block requires that the evaporation of the ether should be slow. This is effected by placing the cup in which the embryo lies imbedded in thick collodion in a saucer containing 36° spirit, and covering the two vessels with a bell-jar. In 12–36 hours the consistence of the mass is examined, and if the embryo appear above the level, more thick collodion is added and the process continued until the desired consistence is attained. The mass is then dug out and cut into a block, which is stuck on elder-pith with collodion. The sections must be stained on the slide, and this is done by coating the sections with glycerin coloured with the staining solution (picrocarmin, Grenacher, alum-carmin, &c.). Owing to the glycerin, there is no fear that the section will dry: an aqueous solution may be used for staining, but in this case the slide must be placed in a moist chamber. In 24 hours the sections are well stained with carmin. The sections are mounted in balsam, but, owing to their size, the benzine and balsam cannot be run under the cover. The sections are first dehydrated with 36° alcohol, the slide is then placed on a warm brick and washed with absolute alcohol, then with benzine, and finally the balsam is dropped or brushed on, and this followed by putting on the cover-glass.

**Schwabe's Sliding Microtome.\***—Schwabe's microtome consists of three separate parts; an oblong support *a* (fig. 109) which also serves for the slide-way, the piece *b* which carries the object, and the knife *c*.

The slide-way *e* is grooved, and *d* flat; in both cases ivory pegs are used to prevent friction, these are shown at *f*, *g*, and *h*. The stability

\* Zeitschr. f. Wiss. Mikr., iv. (1887) pp. 463–4 (1 fig.).

of the carrier is insured by its weight and by its working along the triangular grooved slide-way *e*. In the cross pieces *i k* are several holes, these are for the purpose of altering the angle of the knife *c*, which is fixed by means of the screws *l* and *m*. The angle which the knife makes with the slide-ways depends on the size or diameter of the preparation, and must always be so selected that the edge of the knife can be used as far as possible throughout its extent.

The upper part *b* carries the micrometer screw *n* which moves the object-carrier *o* up and down. This screw has a turn of 1 mm., and as the head is divided into 100 parts the carrier can be raised 0.01 mm. The lower part of the microtome can either be constructed as a pan, or the instrument be placed in one, so that it can be made to work under fluid, and is therefore very useful for the preparation of nervous tissue. In the later constructions the object-clamp is made independent of the micrometer screw for its coarse-adjustment.

FIG. 109.

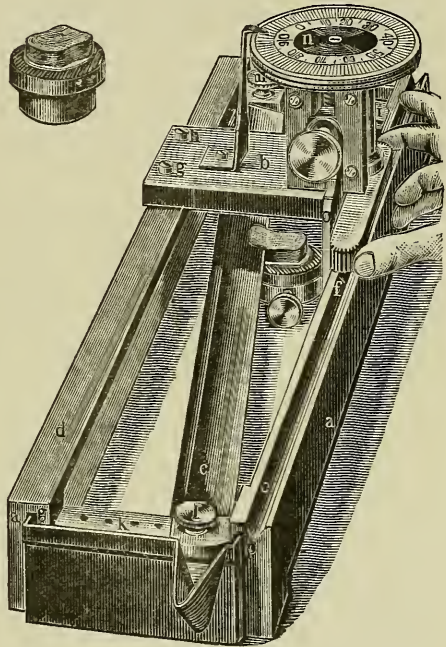

FIG. 110.

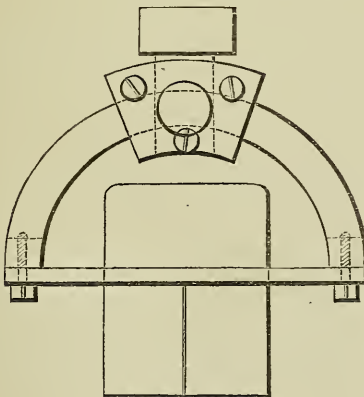
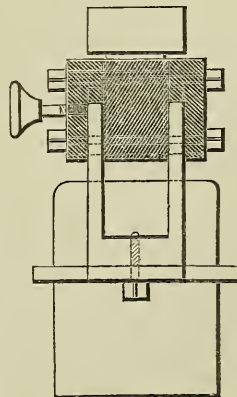

FIG. 111.



Accessory to the Cambridge Rocking Microtome.\*—Dr. H. Zwaardemaker has in conjunction with his amanuensis L. Hasselaer

\* Zeitschr. f. Wiss. Mikr., iv. (1887) pp. 465-6 (2 figs.).

adapted to this microtome an adjunct which is intended to obviate the defect in this instrument of not being able to alter the position of the object in an easy way. Instead of the tube in which the object is fixed with paraffin, the author devised the apparatus shown in figs. 110 and 111. This consists of a copper tube which fits over the main piece, and carries two parallel semicircular rings. Along these half rings runs a steel block, which by means of a binding-screw can be fixed at any point of their circuit. The block carries the small movable cylinder which takes the place of the English contrivance. In use the semicircular rings are placed horizontally, and by combination of the movement along the rings with that of the cylinder about its own axis, the preparation is moved in all directions. But on account of the construction of the microtome, this movement is cramped, and only a turn of  $60^\circ$  instead of  $90^\circ$  is possible. This amount, however, suffices for most cases.

**Inexpensive Section-smoother.\***—Fig. 112 shows a device for preventing the curling of paraffin sections, which Mr. H. C. Bumpus considers is extremely simple and easily made. After cutting off the head and point of an ordinary brass pin, fix it parallel to the edge of

FIG. 112.

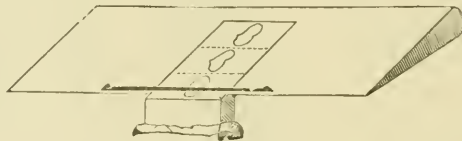

the knife by pressing its ends into two small pellets of beeswax. The proper elevation is easily determined by testing on the waste paraffin before the object is reached. The pin can only be used with the transverse knife. With the knife set obliquely, a piece of drawn wire will serve the same purpose.

**Preparing Long Series of Sections with Celloidin.†**—The procedure which Dr. J. Apáthy advocates very warmly consists in dehydrating the surface of the celloidin block immediately previous to and during the act of sectioning and removing the section to a strip of paper kept moist with bergamot oil. The method in detail is as follows:—

After fixation by any method, and hardening in spirit, the preparation is passed into absolute alcohol, and when imbedded in celloidin kept in 80 per cent. alcohol.

Staining is done *in toto* by the hæmatoxylin and chromic acid method. The strength of the chromic acid salt (mono- or bichromate of potash) is  $1/2$  to 1 per cent., and this, frequently renewed, is allowed to act for not more than one hour. The hæmatoxylin solution is  $1/2$  per cent., and allowed to act for ten minutes to one hour, according to size of object. The object is then washed, and next transferred to spirit, first 70 per cent., then absolute. The imbedding then follows, and when cutting, in the right hand are held a camel's-hair brush and a needle, while this hand also works the microtome. In the left is held a strip of tracing paper, which is at the same time flexible and stiff. The paper strip is about as broad as the slide and thrice as long as the cover-glass. The

\* Amer. Naturalist, xxii. (1888) p. 382 (1 fig.).

† MT. Zool. Station Neapel, vii. (1887) pp. 742-8.

free end of the paper strip, which is well saturated with bergamot oil, is allowed to dip into a capsule of this oil. The surface of the celloidin block is then brushed over with absolute alcohol, the section made and transferred to the oil, from which it is picked up by the needle and arranged on the paper strip. When the required number of sections have been duly placed in position on the strip of paper, the latter is drained. The paper is then laid, the section side downwards, on a carefully dried slide, and then dried with blotting-paper. The paper strip is then carefully removed by rolling it off from one end or corner. If a section should stick to the paper the surface may be moistened with the oil again, and the strip pressed down again, and if this fail it must be taken with a brush and placed in its proper position. When all the sections are properly arranged, the surface is smoothed down and all the oil removed with smooth blotting-paper. The balsam is then applied, and the cover-glass imposed.

The sections, in order to prevent decoloration, should not be allowed to get too near the edge of the cover-glass. In imbedding long objects as certain worms, the process may be hastened by imbedding first the whole object and then cutting it into pieces and arranging these in their proper order in a second imbedding, so that one action of the knife produces ten to twenty sections serially arranged.

**Proper Thickness of Microscopical Sections.\***—Nowadays, says the Editor of the 'Microscope,' it seems to be the aim of many possessors of good microtomes to cut their sections as thin as possible, e. g. from 1/2000 to 1/4000 of an inch in thickness. The origin of this fashion of cutting over-thin sections is difficult to determine, for such sections are, in the majority of cases, quite useless for any purpose of study, and the time involved in their preparation is as good as wasted. It is probably due to a desire to exhibit one's skill without regard for utility—something like that which induces one to write 10,000 words on a post-card, simply because some one else has succeeded in writing 9000.

Friedländer in his excellent little 'Manual of Microscopical Technology,' raises the following objections to sections of extreme thinness:—“(1) They are manipulated with difficulty and considerable time is often lost in spreading them on the slide. (2) The various elements contained in the meshes of these sections are very apt to fall out, and as these are generally of extreme importance, the object of the examination may be defeated. (3) Structures which are sparingly distributed throughout an organ, as, for example, animal and vegetable parasites, are naturally more apt to be discovered in thick sections. (4) In thick sections definite stereometric conceptions of the structure of an object are frequently obtained, inasmuch as several superimposed strata are scanned directly, *in situ et in continuo*, while with extremely thin sections plane images alone appear.” For sections of fresh organs he recommends a thickness of from 1/500–1/250 in.; for hardened preparations from 1/2500 to about 1/850 in. The rule should be, then, not to make sections as thin as possible, but rather to have them of a thickness that will include as many layers as can be clearly studied.

**Preparing Sections from Test-tube Cultivations.†**—Prof. A. Neisser first warms the test-tube containing the cultivation, so that the gelatin

\* The Microscope, viii. (1888) pp. 147–8.

† Centralbl. f. Bacteriol. u. Parasitenk., iii. (1888) pp. 506–10.

cast slips easily out of the tube. According to its size and thickness it is placed for 1-4-8 days in 1 per cent. bichromate of potash solution, which must stand in the light so as to produce a modification of gelatin insoluble in water. The gelatin is then carefully washed and hardened in 70° and 96° spirit. When the desired consistence has been attained the gelatin cast is cut up longitudinally or transversely into pieces, and these are stuck with gum on cork, and then placed in absolute alcohol for twenty-four hours. Before making sections it is advisable to remove the external layer of gelatin, as it is too hard, and interferes with manipulation. Drying, staining, decolorizing, and clearing up are to be carried out on the cover-glass.

For staining the author used—

(1) Löffler's alkaline methylen-blue solution, but did not employ the 1/2 per cent. acetic acid, and decolorized with the spirit. This usually gave good results.

(2) Watery methyl-violet solution (b B extra, Stuttgart Fabrik, Catal. 528) was not so useful, as although the bacteria were well stained, they easily lost their colour.

(3) Gentian-violet in watery solution was a failure, as it had some solvent action on the gelatin.

(4, 5) Bismarck brown and Babes's anilin safranin stained well, but the decoloration of the gelatin was slow and rarely perfect.

(6) Gram's and Weigert's method gave excellent results. The former requires oil of cloves for decolorizing, as spirit alone is insufficient. The decolorized sections should always be cleared up with bergamot oil.

(7) Double staining with anilin methyl-violet, Bismarck brown, or anilin fuchsin-methylen blue did not produce favourable results.

When decolorizing it is advisable to wash in water before using the spirit; clearing up should be performed in bergamot oil, and the specimen mounted in thickened balsam.

Though this method has the advantage of allowing spore-formation to be observed under high powers, of showing the way in which the individuals are disposed, and even of disclosing impurities otherwise unsuspected, it is not available for micro-organisms which fluidify gelatin.

Agar cultivations were manipulated by stripping off small lumps of the cultures and plunging them into agar liquefied at 40°, so that they became imbedded when the agar set. The agar was removed from the tube and hardened just as in the gelatin cultivations, but as it was not susceptible of being sectioned, the pieces were saturated with bergamot oil, then plunged into a mixture of paraffin and bergamot oil, and lastly left in pure paraffin for twelve to twenty-four hours in an incubator. When cooled very fine sections can be made, and the process is then reversed to rid them of the paraffin, and they are then treated like the gelatin sections. The staining is not so satisfactory as with the gelatin method, but the photographic results are very good. A mixture of agar and gelatin was also used by the author for certain organisms which require a firm medium. This method does not offer any other advantage, as the microscopical appearances are deceptive and hardening an impossibility.

CAMPBELL, D. H.—Paraffin-Einbettungs-Methode für pflanzliche Objecte. (Paraffin imbedding method for vegetable objects.)

*Naturwiss. Wochenschr.*, II. (1888) p. 61.

ROMITI, G.—Presentazione di un Microtomo. (Exhibition of a microtome.)

*Atti Soc. Tosc. Sci. Nat. Pisa*, V. (1888) pp. 250-1.

## (4) Staining and Injecting.

**Double-staining of Nucleated Blood-corpuseles.\***—Dr. W. M. Gray gives the following directions:—Spread a thin layer of blood on a clean slide, and dry; immerse the slide in a beaker of alum-carmine (Grenacher's formula) for five minutes; wash in clean water, and immerse in a beaker of a weak solution of sulphindigotate of soda or potash (the solution should be of a dark-blue colour, not black-blue as in a strong solution). After the slide has acquired a purplish hue, wash in water and dry. After drying, warm slightly and mount in balsam. The nuclei will be a beautiful red, and the protoplasm a greenish blue.

**Staining Nerve-endings with Gold Chloride.†**—In his new researches on motor nerve endings, Dr. W. Kühne gives the following as the best methods for manipulating gold chloride:—

(1) Lowit's method, sometimes to be followed by strong formic acid, is especially useful, as thin muscles need not be dissociated.

(2) First, 1/2 per cent. formic acid, gold chloride 1 per cent., then equal parts of a mixture of glycerin and water, to which 1/4 to 1/5 volume formic acid has been added. Specially useful for muscle of warm-blooded animals.

(3) Same as (2), but without preliminary acidulation. For cold-blooded animals.

(4) Golgi's method. 1/2 per cent. arsenious acid, 1/2 per cent. gold chloride of potash, then 1 per cent. arsenious acid, and reduction in sunlight. Useful for all objects.

(5) Modification of 4, consists of laying the strips of muscle in a mixture of 1/2 per cent. arsenious acid, 1/4 per cent. gold chloride of potassium, and 0.1 per cent. osmic acid, then 1 per cent. arsenious acid, and reduction in sunlight. Best suited for reptiles.

With regard to the rest of the preparation, the author says that the finer dissociation should be effected at the most favourable stage of the hardening, therefore always in the gold solution. Secondly, many small bits of muscle (ten to twenty from 1–2 mm. broad) should be placed in 2–5 ccm. of the fluid, which should be allowed to act for different lengths of time, then in the gold solution from four to thirty minutes; from the reduction fluid they are to be removed, say hour by hour, and transferred to unacidulated dilute glycerin. In Golgi's method the separate portions were transferred to fresh arsenious acid in the dark when staining began. In this way various degrees in the effects can be obtained. With the exception of Golgi's all the methods are usually found to overstain, and this has therefore to be removed. The effect of acid on nerve-endings is always disadvantageous; it is, therefore, a great advantage to produce gold preparations without previous acidulation, and the acidulation stage should always be shortened as much as possible.

Preservation of preparations in dilute glycerin acidulated with formic acid is not very favourable for details. Golgi's method, therefore, has a great advantage in not employing glycerin, but mounting in balsam after dehydration in absolute alcohol is perfectly suitable for showing the stained nerve-endings. The certainty of the results varies with

\* Queen's Micr. Bulletin, v. (1888) p. 15.

† Zeitschr. f. Biol., xxiii. (1887) pp. 1–148 (pls. A–Q).

different animals, being most favourable in Reptilia, most unfavourable in the osseous fishes and in the Invertebrata.

**Staining Nerve-endings with Gold Chloride.\***—Dr. G. Boccardi recommends the following method for staining nerve-endings in muscle with gold.

The muscles are treated by Ranvier's method with lemon juice and gold chloride, or the mixture of gold chloride and formic acid; they are then washed in distilled water and the preparations laid for about 2 hours in a 0.1 or even 0.25–0.3 per cent. solution of oxalic acid. A still better mixture is, acid. formic. pur. 5 ccm.; acid. oxalic. 1 per cent. 1 ccm.; aq. destil. 25 ccm. Then wash in water, and mount in glycerin.

**Weigert's Hæmatoxylin Method as applied to other than Nervous Tissues.†**—Dr. P. Schiefferdecker states that Weigert's hæmatoxylin ferridecyanide method can be usefully employed on other tissues than nervous, for example it shows the nuclei of connective tissue well, but has little or no effect on lymph-corpuses, hence its applicability to lymphatic glands for distinguishing between the framework of the gland and the corpuses. It seems to have different actions on blood-corpuses, but it is on the epithelium that its speciality is prominent, the sweat-glands, blood-vessels, and nerves standing out very clearly. Yet on the whole the method seems uncertain, and it is questionable how far the chemical, and how far the physical properties of the tissues are the important factors.

**Staining Mitoses.‡**—Dr. G. Bizzozero and Dr. G. Vassale found the following method gave the best results for fixing mitoses.

The sections made from pieces hardened in absolute alcohol were placed for 5–10 minutes in Ehrlich's fluid (gentian violet 1, alcohol 75, anilin oil 3, water 80), then rapidly washed in absolute alcohol, and then transferred to chromic acid solution 1:1000 for 30–40 seconds, whereupon they were replaced in absolute alcohol wherein they lost part of their colour. To better fix the mitoses it is well to put the sections back again in the chromic acid solution, and afterwards in absolute alcohol. After 30–40 seconds they are placed in oil of cloves; this process may be required to be repeated like the last stage. When no dye is any longer given off in the cloves, the sections may be mounted in dammar. This method gave good results with all tissues and organs. In many cases, however, a still better result was attained by treating the sections, previously to the chromic acid, with the Gram iodine solution (iodine 1, potassium iodide 2, water 300). The former method was found better for lymphatic glands, the latter for those organs in which the nucleus is easily decolorized, e. g. liver, salivary gland, kidney, &c. The foregoing staining method is also available for preparations stained in Flemming's chrom-osmium acetic acid mixture; the sections, however, must be well washed before they are placed in absolute alcohol. But whatever the hardening method, the cell-substance was uncoloured or slightly yellowish; in resting nuclei the nucleoli were slightly stained while the mitoses were violet or almost black.

\* Lavori eseguiti nell' Ist. fisiol. di Napoli, 1886, p. 27.

† Anat. Anzeig., ii. (1887) pp. 680–4.

‡ Arch. f. Pathol. Anat., cx. (1887) pp. 165–244 (1 pl.).

**Staining Leucoplasts, Protein-granules, Bordered Pit Membranes, and Woody Tissue.\***—In his treatise on the morphology and physiology of the vegetable cell, Dr. A. Zimmerman recommends acid fuchsin for staining leucoplasts and chromatophores. After the objects have been placed in a concentrated solution of the dye for some minutes, they are shaken about in a solution of picric acid in 50 per cent. alcohol for one minute, and then washed in 50–70 per cent. spirit. The preparations are mounted in balsam. For the fixation of the protein-granules a saturated solution of picric acid in strong spirit is recommended. When fixed and stained the protein-granules can be mounted at once in balsam. In a mixture of hæmatoxylin and Bismarck brown, woody membranes are stained brown, the others violet. For showing the membrane of the bordered pits in material preserved in spirit, gentian-violet is recommended. The dye is picked up from a watery solution by this membrane, which becomes deeply stained, while others are almost colourless. Next to the bordered pit membrane the middle lamellæ stain best. The sections may be examined in oil of cloves and then mounted in balsam.

**New Method for Staining Fibrin and Micro-organisms.†**—Prof. C. Weigert has devised a modification of Gram's method in which the alcohol and oil of cloves are replaced by anilin oil. The procedure is as follows:—The section (hardening in spirit) is stained with the anilino-gentian violet solution. The staining may be done either on the slide or in a watch-glass. In the latter case the section must be washed with water or with NaCl solution to remove excess of dye before it is placed on the slide. The section is then mopped up with bibulous paper and the iodine solution dropped on; when the latter has acted sufficiently the section is again blotted and then covered with a drop of anilin oil, which must be removed several times as it quickly picks up the stain. The section becomes gradually transparent and the anilin oil is removed with xylol and then mounted in balsam.

If a double stain be desired the additional colour must be imparted before the violet. In this method there is no need to remove the celloidin. By this procedure fungi and pneumonia cocci are more easily demonstrated than by Gram's method, but its principal recommendation is the sharp stain it imparts to threads of fibrin. Bacteria and fungi appear quite dark, almost black, the fibrin threads a beautiful blue.

**New Nuclear Stain and Note on Fixation.‡**—Dr. G. Platner describes a new pigment to which he gives the name nucleus-black. It is imported from Russia as a black solution, and appears to be a metal base in combination with an organic acid. When used in weak solution it is specially adapted for staining nuclei, nucleoli, and axis cylinders, the protoplasm, connective tissue, and nerve-sheath remaining unstained. If used in concentrated solution the staining is more diffused, but may be reduced by alkalis. Thus five or six drops of liquor ammoniæ to a watch-glassful of water or a saturated solution of lithium carbonate diluted, if required, with distilled water, are convenient for limiting the stain to the nucleus and showing up the karyokinetic figures.

\* Sep. Repr. from 'Encyclopædie der Naturwissenschaften,' Abtheilung: Handbuch d. Botanik, Schenk, 1887, 223 pp. Cf. Zeitschr. f. Wiss. Mikr., iv. (1887) pp. 529–30.

† Fortschr. d. Med., v. (1887) p. 228.

‡ Zeitschr. f. Wiss. Mikr., iv. (1887) pp. 349–52.

The time required for staining sections with this nuclear stain is as a rule only a few minutes, but if the material have been hardened in Flemming's mixture 24 hours are necessary. The duration of decolorizing must be judged by the desired effect and from the previous staining. The author notes that this black pigment seems to be very resisting, and the preparations are very suitable for photographic purposes.

The author then proceeds to advocate the use of heat for fixing and preserving material, especially for certain objects such as the ova of *Ascaris megalocephala* which are impenetrable to the action of ordinary reagents. The thin oviduct of the animal is placed in a test-tube and exposed to the action of water at a temperature which need not exceed 50° C., for Max Schulze has shown that the protoplasm is killed and stiffened at this degree. The test-tube must be continually shaken during the heating. The ova are afterwards hardened in spirit which must be increased in strength. Care must be taken not to overheat the preparation, as their form is thereby much altered.

By this method certain details in the ova of *Ascaris* can be brought out which have hitherto escaped notice. For example, certain elements of the equatorial plate, hitherto described as spherical, now appear as short thick rods which by a distinct fissure may be seen to separate into two dumbbell-shaped daughter elements; an important point, as it shows agreement with the ordinary type of nuclear fission.

**Baumgarten's Method of Triple-staining.\***—Dr. A. Lewin says that excellent results are obtainable by means of Baumgarten's triple-staining method, for which the procedure is as follows:—

(1) After having washed the sections in absolute alcohol, they are immersed for five minutes in borax-picrocarmine; excess of stain is then removed with filter paper. This picrocarmine is prepared by adding crystals of powdered picric acid to Grenacher's borax-carminum until the solution assumes a blood-red colour.

(2) The sections are then passed twice successively into absolute alcohol for two minutes; to the spirit picric acid is added until the hue resembles that of hock.

(3) The sections are then soaked in a freshly prepared solution of Ehrlich's gentian-violet (100 parts anilin-oil water and 11 parts alcoholic solution of gentian-violet) for one minute.

(4) The sections are then immersed in Lugol's iodine solution (iodine 1, iodide of potash 2, water 300) for one minute, after which they are washed in absolute alcohol for thirty seconds.

(5) Excess of gentian-violet is removed with acidulated spirit (HCl 3, absolute alcohol 97).

(6) The preparations are then dehydrated in absolute alcohol to which picric acid has been added until the colour is pale yellow (about five minutes). Afterwards the sections are cleared up in oil of cloves and mounted in xylol balsam.

**Anilin-oil Safranin Solution.†**—Dr. V. Babes gives the following modification of his anilin-oil safranin, and which he states gives very superior results. It colours sections almost in a moment, is available for all kinds of tissues, and is especially good for showing up mitoses. To 100 parts of water are added 2 parts of anilin oil and excess of

\* Bull. Soc. Belge de Micr., xiv. (1888) pp. 146-7.

† Zeitschr. f. Wiss. Mikr., iv. (1887) pp. 470-1.

safranin powder. The mixture is then heated to 60°–80° and filtered. Thus made the fluid is clear and deep red, and it will keep for one or two months.

**Metanil-yellow.\***—This is a yellow powder with sp. gr. 1·3102, soluble in water, 12 parts aq. destil. at 16° C. dissolving 0·031 grm. The watery solution is orange coloured and neutral on reaction. On evaporation, crystals are formed which belong to the rhombic system. Dr. H. Griesbach says that, for microscopical investigation it may be used for staining tissues, to which it imparts usually a yellow colour, the tone of which may vary from a bright to a dark hue. It may also be used as a double stain in conjunction with other dyes, such as Congo red, methyl-violet, acid fuchsin, so that a double or triple staining, according to the combination, is effected.

**Simple Method for clearing Methylene Iodide.†**—Herr R. Brauns found quite accidentally a method for clearing methylen iodide which has become brown. Some brownish methylen iodide happened to become frozen, only a small quantity, dark brown in colour, remaining fluid. When the latter was poured off, and the methylen iodide melted, the methylen iodide was found to be of a pale yellow colour and of excellent quality. At 15° C. the sp. gr. = 3·330.

As methylen iodide solidifies at 5° C., it is only necessary to expose it to comparatively slight cold to clarify it in the best and simplest manner.

**Carmine Injections.‡**—Trouble with carmine gelatin fluids when used for micro-injections, arises, says Dr. W. C. Borden, in two ways, either from an excess or deficiency in the amount of acid used to precipitate the carmine. In the first case the carmine precipitates in a too coarsely granular form, in the second, all the ammonia not being neutralized, the ammoniacal solution of carmine will diffuse through the walls of the blood-vessels. The difficulty is obviated by determining beforehand the exact amount of acid which it takes to neutralize a given quantity of ammonia—that quantity which is to be used in the fluid made. To this end take a drachm of aq. ammoniæ, and add gradually, with constant stirring, acetic acid, testing with blue litmus paper. The instant the paper changes to red stop adding the acid and note the amount which has been used. Suppose that it is  $1\frac{5}{8}$  dr., then the proportion of acetic acid will be 11 to 6, and if the amount of ammonia used be 4 dr., then the amount of acid needed will be  $7\frac{1}{3}$  dr. In this way the proper amount of acetic acid to ammonia may be found in any formula. The following formula is recommended as being the best of the gelatin-carmine warm flowing masses.

**Carmine solution:**—Carmine No. 40, 4 dr.; aq. ammoniæ fort., 4 dr.; water, 6 oz. Grind the carmine in a mortar, gradually adding the water, then add the ammonia, and heat gently until the carmine is dissolved.

**Gelatin solution:**—Gelatin,  $1\frac{1}{2}$  oz.; water,  $7\frac{7}{8}$  oz. Soak the gelatin in the water until soft, and then dissolve by heating. Take 5 oz. of the gelatin solution and add to it the solution of carmine. Add to the remainder of the gelatin solution sufficient acetic acid as found by previous trial to neutralize 4 dr. of ammonia contained in the carmine solution.

\* Zeitschr. f. Wiss. Mikr., iv. (1887) pp. 439–62 (4 figs.).

† Neues Jahrb. f. Mineral., Geol. u. Palæontol., 1888 (i.) pp. 213–4.

‡ Amer. Mon. Micr. Journ., ix. (1888) pp. 39–41 (1 fig.).

Heat the solution containing the carmine and that containing the acid to the same degree, by placing the bottles containing them in a pan of water kept hot on a stove or over a lamp. Add gradually with constant stirring the gelatin solution containing the acid to that containing the carmine. Filter while hot through two thicknesses of flannel. The fluid can be poured into the flannel shaped into a bag, when pressure on the sides of the bag will cause the contained fluid to pass through the cloth. Add four dr. of chloral hydrate and shake until dissolved. The chloral will preserve the mass for quite a long time, but if it is to be used within a day or two the chloral is not necessary. A mass made up by the formula given is sufficient in amount to inject a cat or rabbit. If needed for a single organ the ingredients can be reduced to the relative proportion.

A manometer should always be used for injecting and the apparatus suggested by the author consists of a wide-mouthed bottle fitted with a manometer made from a piece of bent glass tubing fastened to an upright board with a scale in inches or millimetres marked on it. The only other articles necessary are a tin box with a shelf inside on which to lay the animal to be injected; a sheet of glass large enough to cover the box, a thermometer, a few feet of rubber and glass tubing, and a couple of spring clamps for closing the tubing when it is necessary to stop the flow. Good atomizer bulbs are also required. There is no difficulty in maintaining a pressure of 100 mm. while injecting.

Before making an injection the apparatus should be tested by closing the exit tube and gradually raising the pressure to 100 mm., in order that any defects may be remedied. Before killing the animal the box is filled below the shelf with water at 40° C., and a lamp placed underneath to keep the temperature at that point. The melted injecting mass is then poured into the injecting bottle in order that it may attain the same temperature. About 12 oz. of a 3/4 per cent. salt solution is poured into another bottle also arranged with injection-tubes and placed in the box. The animal is chloroformed, and the apex of the heart having been snipped off, the salt solution is injected at a pressure of 50 mm. until it runs clear. The carmine mass is then injected, beginning with a pressure of 50 mm., and gradually increased to 100 mm. When the injection is finished the animal is cooled down in ice-water or a refrigerator, and the selected parts afterwards hardened in spirit.

Robin's, Lacaze-Duthiers', and Farabœuf's Injecting Syringes.\*—Dr. Beale † prefers the syringe to any of the contrivances described in this Journal, 1884, pp. 643-51, for producing pressure by the fall of a liquid. The ordinary syringe has, however, several inconveniences which it is the object of the following modified forms to remedy.

Robin's syringe (fig. 113), has a rack-and-pinion movement to the piston so as to avoid the dangerous irregularities of pressure which are very liable to occur, especially after prolonged work. It also has a second tube and tap at the side for taking up the injecting fluid.

\* Fol's Lehrbuch der Vergl. Mikr. Anatomie, 1884, pp. 21-4 (3 figs.).

† "After having tried many different methods of proceeding, I find that upon the whole the ordinary injecting syringe is the most successful as well as the cheapest, the most convenient, and the most simple instrument, and it is very easily kept in good order. It need scarcely be said that by no mechanical means can such varieties of pressure be obtained as by the aid of the muscles of the fingers and thumb, while the pressure can be instantly modified or removed at the pleasure of the operator."—'How to work with the Microscope,' 1880, p. 104.

Lacaze-Duthiers' (fig. 114), has also a rack-and-pinion arrangement and double tube but is designed to obviate the difficulties found to arise in many cases from movement of the syringe, as well as unequal pressure. It is attached to a heavy base, so that it will stand upright by itself, and a disc is placed on the top of the piston for weights, by which the piston can be made to descend automatically and at any given rate. The

FIG. 113.

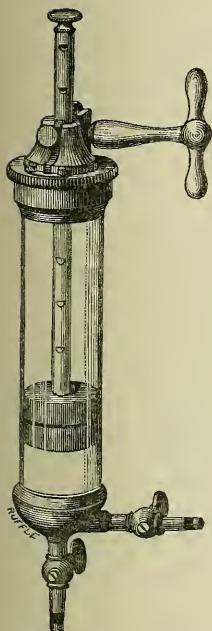
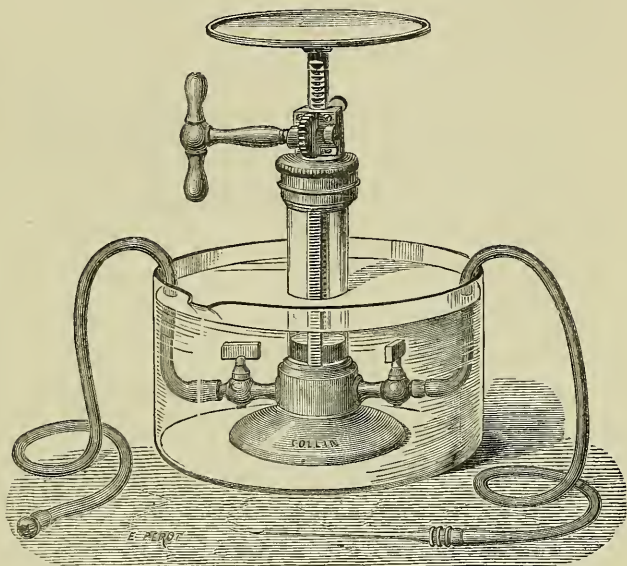

FIG. 114.



syringe can be placed in a vessel of warm water when it is necessary to keep the injecting fluid at a given temperature. M. Robin\* preferred, instead of the disc, a stretched indiarubber band, which passes through a ring at the top of the piston, the ends being fastened to the cylinder. The two tubes can be used for injecting two orders of vessels simultaneously.

Farabeuf's (fig. 115) is covered with a non-conducting material so as

FIG. 115.

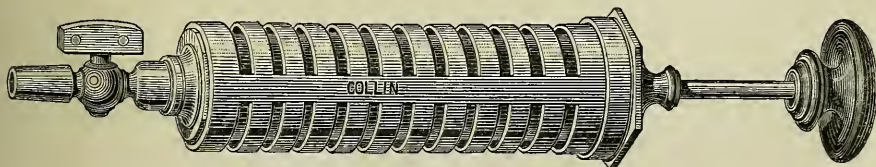

to protect the hand from the heat when fluids are used which must be kept very hot. The intervals allow the contents of the glass syringe to be seen.

\* Robin's 'Traité du Microscope,' 1877, pp. 990-1 (1 fig.).

**Collin's Automatic Cannula-holder.**—On the other hand, Prof. H. Fol \* prefers a pressure arrangement, on the ground that with all forms of syringe the leather dries up when it has not been used for some time, with the result that when the syringe is wanted it is not in a serviceable condition.

Whatever form of pressure-apparatus is used, it is very convenient, he points out, to have a cannula-holder with an automatic closing arrangement, such as that of MM. Collin shown in fig. 116.

FIG. 116.

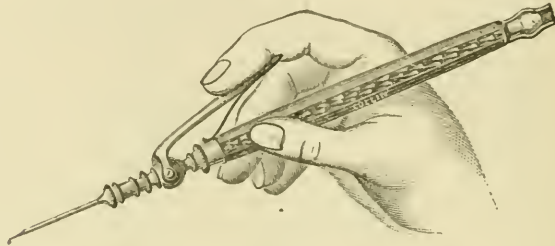

The holder is hollow, and is connected with the tube from the pressure apparatus. Having been filled with the fluid, and some having been allowed to run out of the cannula, the cock is closed and the cannula is placed in the vessel to be injected, the holder being held in the hand like a pen. By pressing the lever the flow of the fluid can be regulated as desired. Prof. Fol says, "Whoever has worked with such an instrument will hardly again use the old syringe, especially where difficult injections of invertebrate animals have to be performed."

(5) Mounting, including Slides, Preservative Fluids, &c.

**Half-clearing method of preparing Nerve Sections.**†—Dr. Byrom Bramwell lays the section previously stained with carmine on a slide, and then pours on methylated spirit; the spirit is then mopped up, and a small quantity of oil of cloves poured on. While the preparation is still cloudy the oil of cloves is drained off quickly, and having been replaced by Canada balsam, the cover-glass is put on. The results attained, although in some cases extremely good, are eminently uncertain on the whole, the preparations being spotty, irregularly or too much cleared up.

**Adaptation of Kaiser's gelatin for arranging microscopic preparations in rows.**‡—Signor A. Poli commends to the notice of botanists, especially for the preservation of algæ, the mixture of gelatin and glycerin known as Kaiser's glycerinated gelatin, as first proposed by Nordstedt, and recommended in Strasburger's 'Botanisches Practicum.' He finds it especially convenient when it is desired to arrange a number of minute objects in rows under the same cover-glass. A fine streak of the fused gelatin, which melts at 45° or even lower, is first placed on the

\* Fol's Lehrbuch, p. 24 and pp. 25-6 (1 fig.).

† Edinburgh Med. Journ., Oct. 1886.

‡ Malpighia, ii. (1888) pp. 107-9.

slide by a very fine brush, at the spot intended to be occupied by the object, which is then deposited on the gelatin by a pencil, and adheres to it directly, and the cover-glass at once placed on. If they do not adhere immediately, the slide may be slightly warmed, and then allowed to cool.

**Purification of Tolu Balsam for Microscopical Purposes.\***—Herr C. C. Keller who has already advocated the use of tolu for mounting diatoms, gives the following method for purifying the balsam. 1 kilogramme of crude tolu balsam is heated in a water-bath until it is completely melted, when an equal quantity (up to 1200 grm.) of pure spirit of at least 95 per cent. is added. The solution is then filtered, and to it are added 500–600 grm. of petroleum ether in small portions. At first a clear solution results, the petroleum ether being taken up by the alcoholic balsam solution, but soon it separates into two layers. It is then shaken up vigorously, and allowed to stand for 24 hours. Two clear layers are then found, the upper yellowish one consisting principally of cinnamic and benzoic acids, the lower brown one being composed of the tolu resin plus much cinnamic and benzoic acids dissolved in alcohol and a little petroleum ether. The two layers are next separated by decantation. The following step consists in heating 4 litres of distilled water in a capacious vessel almost up to boiling point, and when the flame is put out the resinous solution is poured slowly in. As the petroleum ether boils at  $65^{\circ}$ – $75^{\circ}$  C. it disappears, the resin is precipitated, and when cold the cinnamic and benzoic acids crystallize out. The resinous mass is then stirred up several times with boiling water in order to get rid of the last traces of the acid. The resin is best dried over sulphuric acid or by the aid of gentle heat, and dissolved in benzol or chloroform. If, as may happen, when dried by heat, the balsam becomes red or brown-red, it should not be used.

FIG. 117.

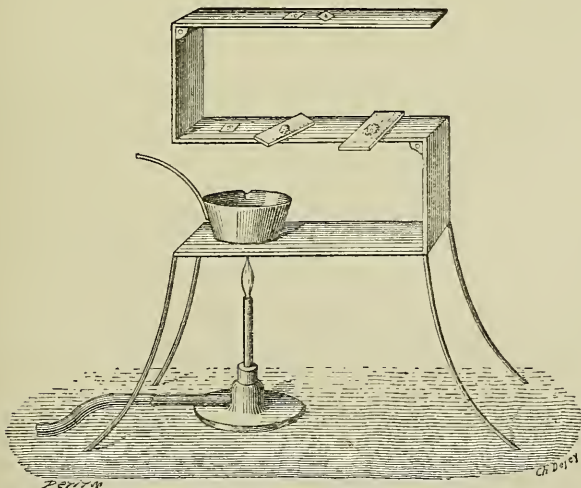

**Hot Plate Apparatus.†**—It is useful for microscopists to have at hand an apparatus capable of being heated to different temperatures in

\* Zeitschr. f. Wiss. Mikr., iv. (1887) pp. 471–4.

† Arch. de Physiol., viii. (1886) pp. 273–5 (2 figs.).

order to melt paraffin mixtures of wax and oil for imbedding, for heating specimens mounted in balsam, for drying and coagulating blood, sputum, &c. For this purpose M. L. Malassez has devised the apparatus (fig. 117) which consists of a metal plate bent into the shape of a capital S. The whole length of the plate is 50 cm., and it is 6 cm. broad and 2·5 mm. thick. The apparatus takes up very little room, as it is only 12 cm. long, 12 cm. high, and 6 cm. broad. It may be heated from below or

FIG. 118.

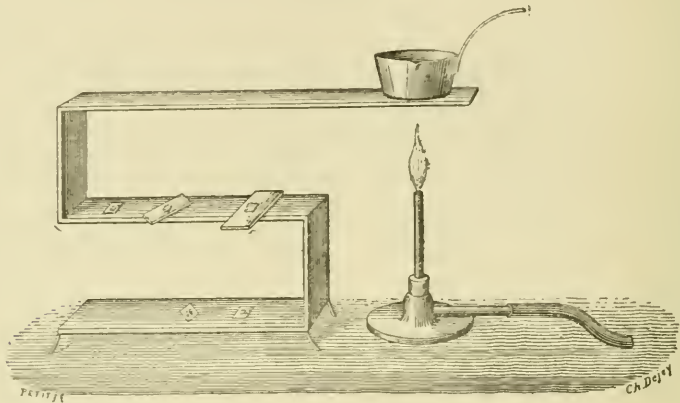

from above; if from below it must be supported on four legs, and the Bunsen burner placed underneath (fig. 117). If from above, then the topmost shelf must be made to project so that the burner can go underneath (fig. 118).

**MACDONNELL.**—[Exhibition of Slides.]

[“Three dozen slides (chiefly entomological, and sections of wood) mounted by Mr. H. Sharp in balsam in an ingenious manner, so as to obviate pressure and distortion of the object, by pasting a rim of paper on the slide, and thus leaving a space of any requisite thickness for the object. This process was invented by Mr. Sharp, of Adelong, and the results were excellent.”]

*Journ. and Proc. Roy. Soc. of N. S. Wales, XXI. (1887) p. 294.*

**MINOT, C. S.**—The Mounting of Serial Sections.

[Summary of existing state of knowledge on the subject.]

*The Microscope, VIII. (1888) pp. 133-8.*

(6) **Miscellaneous.**

**Method of calculating the rapidity of Bacterial Increase.\***—Drs. H. Buchner, T. Longard, and G. Riedlin, who have been investigating the rapidity with which certain micro-organisms increase, remark that the following six conditions must be fulfilled in any attempt to determine maximum rapidity of development:—(1) The nutrient medium must be as favourable as possible (they used cold meat infusion: peptone 5 per cent., sugar 1 per cent., salt 1/2 per cent.; solution alkaline; in some

\* *Centralbl. f. Bacteriol. u. Parasitenk., ii. (1887) pp. 1-7 (1 fig.).*

cases the sugar was omitted). (2) The temperature must be the most favourable— $37^{\circ}$  C. (3) The cultivation must be not only pure, but strong. (4) The number of individuals in the nutrient medium must be accurately determined; this number must be small. (5) At the conclusion of the experiment the number of individuals must also be calculated. (6) The duration of the experiment must be known, and also short (2–5 hours).

The actual procedure was as follows:—From a pure cultivation of the bacillus in the meat-peptone solution a small quantity on a platinum wire is transferred to 50 ccm. of a sterile 0.6 per cent. salt solution. After having been well shaken up, 1 ccm. is taken up with a pipette and transferred to 50 ccm. of meat-peptone solution. With the last solution, which contains at most a couple of hundred individuals to the cubic centimetre, three plate cultivations are made with 1 ccm. each of the solution. In this way the bacterial contents of the solution are determined with sufficient accuracy. These quantities having been removed, the nutrient solution, which has previously to the inoculation been raised to  $37^{\circ}$  C., is kept at this temperature for 2–5 hours. At the expiration of this time three more (secondary) plate cultivations are inoculated with 1 ccm. each of the solution. This gives the number of individuals present at the conclusion of the experiment.

The enumeration of the colonies was made by numbering those visible under the field of the Microscope and striking an average from 10–30 such enumerations. The gelatin layer of the plate should be perfectly even, and not too thick. Having obtained the average number of colonies to the field of vision, and then having ascertained the size of the field, the number of colonies on the whole plate was calculated. As the size of the field for a given objective diminishes with the strength of the eye-piece, the size of the field for each individual eye-piece should be determined once for all. The higher eye-pieces with the smaller fields are more convenient for the more thickly crowded plates.

This method may be further developed by adapting to the diaphragm of a high eye-piece two pairs of crossed threads (fig. 119). The distance between the threads should amount to about  $1/10$ – $1/12$  of the diameter of the diaphragm. The small square in the middle of the field is convenient for enumerating very thickly sown colonies. The number of colonies seen within the small square is ascertained at many different places of the cultivation plate. Colonies which happen to lie on the boundary of the square are only numbered if their larger half fall within the square. From many enumerations an average is obtained which serves as a basis for calculating the contents of the colonies of the whole plate. In this way a plate with 5–10 millions of colonies can be numbered.

In the eye-piece used by the authors the small square had the apparent size of 1.7 sq. cm., but the actual space with the objective used was 0.0156 sq. cm., that is, the 6410th part of a sq. cm. If, therefore, there were ten colonies to the square, in the gelatin layer of 80 sq. cm. superficies there would be a total of 5,128,800 colonies.

FIG. 119.



The method for calculating was as follows:—

$$\begin{aligned}
 \text{Let } a &= \text{number of primary colonies.} \\
 b &= \text{secondary colonies.} \\
 n &= \text{generations.} \\
 a \text{ cells or rods after 1 generation} &= a \times 2. \\
 2 \text{ generations} &= a \times 2 \times 2. \\
 n \text{ ,,} &= a \times 2^n. \\
 \therefore a \times 2^n &= b. \\
 2^n &= \frac{b}{a}. \\
 n &= \frac{\log_b - \log_a}{\log_2}.
 \end{aligned}$$

The cholera vibrio was chiefly experimented on, and the results of seven examinations are given. In number these are too few for any precise knowledge; in certain details of time they vary considerably, and the last experiment given was apparently the first made, and seems to have been thrown in to add length to a too short series.

The following are the numbers given:—

*Experiment 1.* (Feb. 1887.) Duration 3 hours.

$$\begin{aligned}
 \text{Primary colonies} &= 18 \\
 \text{Secondary ,,} &= 7250 \\
 n &= 8.7
 \end{aligned}$$

$\therefore$  each brood developed in 20.7 minutes.

*Experiment 2.* (Feb. 1887.) Duration 3 hours.

$$\begin{aligned}
 \text{Primary colonies} &= 149 \\
 \text{Secondary ,,} &= 95,952 \\
 n &= 9.3
 \end{aligned}$$

Period of development = 9.3 minutes.

*Experiment 3.* (Feb. 1887.) Duration 2 hours.

$$\begin{aligned}
 \text{Primary colonies} &= 3,583 \\
 \text{Secondary ,,} &= 90,666 \\
 n &= 4.7
 \end{aligned}$$

Period of development = 25.5 minutes.

*Experiment 4.* (March 1887.) Duration 2 hours.

$$\begin{aligned}
 \text{Primary colonies} &= 15,345 \\
 \text{Secondary ,,} &= 133,545 \\
 n &= 3.1
 \end{aligned}$$

Period of development = 38.7 minutes.

*Experiment 5.* (March 1887.) Duration 2 hours.

$$\begin{aligned}
 \text{Primary colonies} &= 3,550 \\
 \text{Secondary ,,} &= 27,608 \\
 n &= 3
 \end{aligned}$$

Period of development = 40 minutes.

*Experiment 6.* (April 1887.) Duration 2 hours.

$$\begin{aligned}
 \text{Primary colonies} &= 143 \\
 \text{Secondary ,,} &= 1291 \\
 n &= 3.18
 \end{aligned}$$

Period of development = 37.7 minutes.

*Experiment 7.* (June 1886.) Duration 5 hours.

Primary colonies = 35

Secondary „ = 981,792

*n* = 14·8

Period of development = 20·3 minutes.

It may be noted that either the period of development of each brood varied considerably, or the method of experimentation or of calculation was at fault.

**Analysis of Water used for Brewing as regards Micro-organisms.\***

—The examination of drinking-water, remarks Dr. E. C. Hansen, is made by means of Koch's plate-cultivation method, by means of meat-peptone gelatin; and this method is also employed in zymotechnical laboratories. But for the analysis of water used in brewing another method must be adopted. The question at issue is not so much to find out what and how many micro-organisms exist in the water, nor what will develop in gelatin with or without the addition of meat and peptone, but rather how the water behaves towards the wort and the beer, to what degree it is rich in micro-organisms which can develop in these media, and if among them there be any kinds capable of exerting a detrimental action. The analysis, in short, must be carried out under conditions obtaining in the brewery itself.

The nutrient solutions, the beer and the wort, are placed in small flasks plugged with cotton-wool. Each flask, fifteen filled with beer and fifteen with wort, was inoculated with 0·02 cm. of cold tap-water. The water was inserted by means of a pipette, the upper end of which was fixed to a rubber tube, in order to prevent any germs entering from the air. The number of drops was regulated by means of a stopcock. It need hardly be remarked that the apparatus and the media were carefully sterilized. Also, the amount of water placed in each bulb was accurately measured, in order that the result could be calculated up to 1 cm.

For the sake of comparison, an analysis was made by Koch's method from the same water, and also on another plate; but instead of meat-peptone gelatin; wort-gelatin (wort with about 5 per cent. gelatin) was used here. The cultivations were placed in a thermostat at 24°–25° C., and the experiment was suspended after fourteen days. None of the beer- or wort-flasks contained a trace of vegetation. In Koch's gelatin there were 111 spots of vegetation, that is 222 for 1 ccm. water; all contained bacteria, but only a few fluidified the gelatin. The wort gelatin showed fifteen vegetations, or thirty to 1 ccm. water. Other experiments gave analogous results, and on the whole showed that while the hygienic method put the total too high, the estimates from the wort-gelatin cultivations were too low, and that very few of the bacteria present in the water had any effect on the wort, and none at all on the beer. Yet, when both of these fluids were much diluted, they lost their original power of resistance, but then of course they were neither what is usually understood by beer and wort.

Some further experiments established the fact that bacteria from water, even though introduced in large quantity, were unable to develop in beer, but hyphomycetes of water occasionally did so.

Based on these observations, the author made an analysis of the

\* Centralbl. f. Bacteriol. u. Parasitenk., iii. (1888) pp. 377–9, from Zeitschr. f. d. Gesell. Brauwesen, 1888, No. 1.

properties of the Alt-Carlsberg water. Fifteen flasks of beer and fifteen flasks of wort were inoculated with one drop of water (0.04 ccm.) and ten flasks of each sort with 1/4 ccm. of water; they were then shaken up, and for fourteen days kept at a temperature of 24°-25° C. The result was that 1 ccm. water contained 1.3 wort-bacteria and 1.3 moulds, or 2.6 vegetations altogether. They were all in the wort; the beer was quite unaffected.

- BROWN, F. W.—A Course in Animal Histology. II. (*concluded.*)—Practical Work. *The Microscope*, VIII. (1888) pp. 145-7.
- DETMER.—Das Pflanzenphysiologie Praktikum. (Practical Vegetable Physiology.) 352 pp., 8vo, Jena, 1888.
- DUBIEF, H.—Manuel pratique de Microbiologie comprenant les Fermentations, la Physiologie, la Technique histologique, la culture des Bactéries et l'étude des maladies d'origine bacterienne. (Practical Manual of Microbiology, comprising Fermentations, Physiology, Histological Technique, the culture of Bacteria and the study of the diseases of bacterial origin.) 600 pp., 162 figs. and 8 pls., 12mo, Paris, 1888.
- EGE, J.—The value of microscopical examination of Phthical Sputum as a means of giving a correct Prognosis. *Queen's Micr. Bulletin*, V. (1888) p. 16.
- HESSE, W.—Zur quantitativen Bestimmung der Keime in Flüssigkeiten. (On the quantitative determination of germs in fluids.) *Zeitschr. f. Hygiene*, IV. (1888) pp. 22-4.
- HIS, W.—STRASSER, H.—Ueber die Methoden der plastischen Reconstruction und über deren Bedeutung für Anatomie und Entwicklungsgeschichte. (On the methods of Plastic Reconstruction and their importance for Anatomy and Embryology.) *Anatom. Anzeiger*, II. (1887), pp. 382-92, 392-4.
- KASTSCHENKO, N.—Eine kurze Notiz in Bezug auf meine Methode. (A short note in reference to my method.) *Zeitschr. f. Wiss. Mikr.*, IV. (1887) pp. 353-6.
- MAYER, P.—Aus der Microtechnik. (Microtechnique.) *Monatschr. f. Anat.*, 1887, 10 pp. and figs.
- MAYER, S.—Histologisches Taschenbuch. (Histological Pocket-book.) 9 Hefte and 158 figs., 8vo, Prag, 1887.
- M'CASSEY, G. H.—Microscopy and Histology for Office Students. *Arch. of Dent.*, 1887, May.
- NELSON, S. N.—Methods of examination of Bacteria for laboratory purposes. *Journ. Amer. Med. Assoc.*, 1888, pp. 381-6.
- OSBORN, H. L.—Studies for Beginners. II. *Amer. Mon. Micr. Journ.*, IX. (1888) pp. 85-6.
- PARKER, W. N.—On the objects of the Biological and Microscopical Section of the Cardiff Naturalists' Society. *Rep. and Trans. Cardiff Naturalists' Soc.*, XIX. (1887) pp. 107-10.
- PEAL, C. N.—Microscopy for Beginners. [Report of Lecture.] *Ann. Rep. Entom. and Nat. Hist. Soc. for 1887-8*, 4 pp.
- RANVIER, L.—Traité technique d'Histologie. (Technical Treatise on Histology.) Fasc. VII. (and last), pp. 977-1109, figs. 325-79, 8vo, Paris, 1888.
- SANDERSON, B., FOSTER, M., and BRUNTON.—Manuel du Laboratoire de Physiologie. (Manual of the Physiological Laboratory.) *Transl.* by G. Moquin-Tandon. ii. and 620 pp., 184 figs., 8vo, Paris, 1888.
- STÖHR, P.—Lehrbuch der Histologie und der mikroskopischen Anatomie des Menschen mit Einschluss der mikroskopischen Technik. (Handbook of Histology and Human Microscopical Anatomy, including Microscopical Technique.) 2nd ed., 209 figs., 8vo, Jena, 1888.
- TIEMANN, F.—Illustrierter Leitfaden für die praktische mikroskopische Untersuchung des Schweinefleisches auf Trichinen. (Illustrated guide to the practical microscopical investigation of hog's flesh for Trichinæ.) 3rd ed., 8vo, Breslau, 1887, viii. and 139 pp., 29 figs.
- ZUNE, A.—Cours de Microscopie médicale et pharmaceutique. (Course of medical and pharmaceutical microscopy.) *Contd.* *Moniteur du Praticien*, III. (1887) pp. 190, 215, and 249.

## PROCEEDINGS OF THE SOCIETY.

MEETING OF 13TH JUNE, 1888, AT KING'S COLLEGE, STRAND, W.C.,  
W. T. SUFFOLK, ESQ., VICE-PRESIDENT, IN THE CHAIR.

The Minutes of the meeting of 9th May last were read and confirmed, and were signed by the Chairman.

The List of Donations (exclusive of exchanges and reprints) received since the last meeting was submitted, and the thanks of the Society given to the donors.

	From
Cutter, E., Clinical Morphologies. xviii. and 81 pp. (8vo, New York, 1888) .. .. .	The Author.
Slides (12) of Foraminifera from the London Clay, Wimbledon ..	Mr. W. Godden.
Slides (9) and 21 drawings of Insect Preparations .. .. .	Mr. F. Enock.
Diatomaceous Earth from Oamaru, N. Z. .. .. .	Mr. W. L. Watson.

Mr. Crisp said that a letter had been received from the President expressing his great regret and disappointment at being unable again to be present, but his visit to London last time had been rather too soon, and he had been thrown back again in consequence. The President had in fact offered to resign, but of course they could not entertain that suggestion, especially as there would not be another meeting until October, by which time they hoped that Dr. Hudson would be completely recovered.

Mr. A. W. Bennett said it would probably interest the Society to know that an exceedingly rare Alga had lately been found in this country at Kew, where it was discovered in considerable quantity. This was especially interesting because, although mentioned by Dr. M. C. Cooke as a British species it had, so far as he was aware, never been found in England before. This species, *Sphæroplea annulata*, was well marked and exceedingly interesting in several particulars. He thought this must be regarded as the most interesting discovery of the kind which had been made in this country for many years.

Mr. J. Deby exhibited slides, mounted at his request by Mr. F. Enock, of a curious and interesting Dipterous insect collected by himself at Biarritz during the latter days of April last. This small fly does not possess the pelagic habits of *Halobates*, so well figured and described by Mr. Buchanan White, but is strictly a littoral marine form, whose larva lives among the green algæ, which along that iron-bound coast cover all the rocks between tide-marks. The adult form is found swarming on the wet sea-weed as the tide recedes, and seems to enjoy the sunshine. Its movements are remarkably swift, and its life must be short as the waves of the Bay of Biscay break in heavy surf upon these rocks at high tide. A peculiarity of this dipteran is that the male is possessed of only rudimentary and nervureless wings, while those of the female are nearly obsolete, so as to make this last resemble a dark-coloured overgrown louse, when observed superficially.

The structure of the insect's foot is very remarkable and beautiful as seen under the Microscope, being furnished with a singular comb-like branching apparatus facing the two ordinary claws. The habits of the insect are also peculiar, as the males, which are furnished with a powerful pair of anal foreceps, are in the habit of using these for the purpose of seizing the females by the back of the neck and dragging them along, seemingly much against their will, while stopping ever and anon to allow their spouses to oviposit among the weeds or in minute crevices in the bare rock. Not having had time to wade through the bibliography of this tribe of insects he deferred describing it until its novelty had been fully ascertained. It evidently belongs to the division *Nemocera-Tipularia*, having six joints to the antennæ. Its details can only be studied with advantage under the Microscope, as its total length does not exceed  $\frac{1}{4}$  in. Mr. C. Waterhouse of the British Museum stated that the insect did not exist in the collection, but that it is very like the *Halirytus* of the Rev. A. Eaton, found in exactly similar conditions at Kerguelen Island. The European insect is in consequence most probably generically and specifically new to science.

Mr. Deby also exhibited a series of sections of the Myrmecophilous plants, *Myrmecodia tuberosa* and *Hydnophytum formicarium*, from Java, brought back in spirits by himself from Buitenzorg, through the kindness of Dr. Treub who gave him the living plants. The stained sections, of unusually large size, were beautifully prepared by Mr. A. Cole. Natural size drawings of the plants and of the sections of their tubers executed by the late Mr. Draper (being the last performances of this artist before his death) were also shown.

These sections seem to demonstrate successfully that the cork lining of the cavities is always quite continuous, and that lenticellæ, or some similar structures, exist abundantly within them. This, Mr. Deby thought, demonstrates that the ants have had really little or nothing whatever to do with the formation of these curious meandering excavations in which they live. Thus Mr. Deby considered that Dr. Treub in his original communication published in the 'Annals of the Botanical Garden of Buitenzorg,' was nearer the truth in this matter than were MM. Beccari, Forbes, Huth, Moseley, Wallace, and J. Brittain. The ant infesting both these plants in Java is the *Iridomyrmex cordata* Sm. var. *Myrmecodiæ* Emery. In many specimens of flourishing plants, not a sign of ants was to be seen, while in many they were very few in number; thus contradicting the assertion that the plants cannot live without the ants.

Prof. Stewart said that Mr. Deby's observations showed how important it was to use one's eyes, even in places where it might be supposed that the fauna and flora were thoroughly well known. The question now seemed to be whether if the original cavities had been made by ants it might in course of time have come to be a race peculiarity.

Mr. H. B. Brady said that in confirmation of the remark as to the desirability of collecting under all circumstances he might mention that having to visit the cinchona plantations he found there an insect pest which was said to be *Helopeltis Antonii*, and was supposed to be the same insect as that which ravaged the tea-plantations of Assam. On inquiry, he afterwards found that there was no specimen at the British Museum, and on further investigation it turned out not to be *Helopeltis* at all, but another species altogether.

Mr. A. D. Michael said that the account which Mr. Deby had given of the Dipterous insect was of very great interest; the point which struck him most being the kind of parallelism shown to what was found in the case of some of the Calcididæ. Most of the members of this family were free-flying creatures, but from the fact of many kinds acquiring running habits the wing power had been lost, the organs becoming small and feeble. The degradation of the wings in the specimens shown might probably be due to a similar alteration of habits. With regard to the peculiar foot, there were one or two instances of a similar kind found amongst the outlying groups of the Diptera, which were chiefly parasitic, where, between the properly developed claws, the sucker had been modified into a comb-like structure, which was very curious, and was certainly an approach to that shown in the specimen exhibited.

Prof. Stewart said they had a familiar example of the reverse of this process in cases where the comb-like structure was the usual form in the case of some of the spiders. Usually amongst spiders there was a claw deeply toothed in the manner so well known to all who had examined a spider's foot, but in the case of the hunting spiders this had been developed into a sucking foot.

---

Mr. Crisp read a letter from Mr. Enock, in which he said that having succeeded in tracing out the life-history of the Hessian fly, he hoped to be able to exhibit a complete set of slides at the meeting.

Mr. Enock said that having unfortunately spoilt one of the slides, he was unable to show a complete series that evening; he hoped, however, to be in a position to do so on a future occasion. He had bred both the American and the Russian species to see if they were the same as those found in this country, but he found that whilst Dr. Reinsman (?) said they laid from 80 to 100 eggs, the first specimen he bred laid 158 eggs on a stalk of barley. He had spent a great amount of time in watching the transformation of the fly, which emerges generally between 4 and 5 a.m., though he had found them in the act soon after 3 a.m.

---

Mr. Crisp called attention to two slides which had been sent by Mr. Cole, and asked Prof. Stewart to describe them.

Prof. Stewart said that the first of these was a section of the eye of a newt, which showed most of the features of the retina, and at the same time the general relations of the other elements of the eye. The other slide was a section of the head of the human embryo, a thing always difficult to obtain, especially in a sufficiently fresh condition for cutting sections of much value. This slide was labelled as showing the primary and secondary optic vesicles; this however was a slip, because it was not possible for these to be seen at the same time. Prof. Stewart then, by means of drawings on the blackboard, described the process of development of the eyes in the embryo, and showed the difference between the primary and secondary vesicles with their relation to the ultimate structure of the organs.

---

Mr. Badcock said that he had the pleasure on one or two occasions of calling attention to a pond which in all his experience of collecting was the most extraordinary he had ever found, in consequence of the rarity of the forms and the variety to be obtained from it. Dr. Millar had asked him more than once to write a paper or to make a cata-

logue of the various forms of life to be found there, and as the pond was almost within a stone's throw of where he lived, he had promised to do so in the course of this summer. But to his great dismay the Metropolitan Board of Works, who had taken over the management of some of the parks, had carted rubbish into these ponds, with the idea of improving them, but of course with the result of destroying them. Two or three years ago the Corporation of London began the same process at Epping Forest, with the object of trying to make it pretty; a deputation waited upon them on the subject, and succeeded in preserving something. As regarded the pond in Victoria Park, it was especially to be regretted on account of the great variety of forms which had been thus destroyed.

Mr. Inghen said he could quite confirm all that Mr. Badcock had said by his own experience of the similar doings of the Board on Wimbledon Common and Putney Heath, where the old ponds had been completely spoilt. In some instances a pond of some years' standing had found its natural level, but by cutting a trench from the pond not only had it been spoilt, but the neighbouring ground had been converted into a quagmire.

Mr. Crisp called attention to two slides which had been sent up by Dr. Peter Yates, of Bolton Infirmary, and which were exhibited under Microscopes in the room. They consisted of thin transverse sections cut with a Cambridge microtome of *Sycon ciliatum*, a calcareous sponge surrounded by a siliceous sponge, *Isodictya varians*—a very curious and rather abnormal condition. Also sections of *Sycon ciliatum* cut longitudinally, showing ova, &c., but especially noticeable for the fine specimens of entomostracans which back to back filled up the cloacal cavity within the *Sycon*. These entomostracans do occasionally find shelter within the *Sycon*, but these seem so large that it was suggested they had grown with the sponge's growth. The slides were mounted by Dr. Yates from specimens gathered in Jersey by Mr. George Swainson, F.L.S. Sarcode stained blue-black.

Professor Stewart said he had looked at these specimens, but could scarcely reconcile the appearance with ordinary facts, because where, as on the Devonshire coast, they constantly found sponges of various sorts growing up together, they found that as a rule they stopped short as soon as they touched, and there was nothing like union between them. In one of the specimens shown a siliceous sponge had apparently completely surrounded a calcareous one, without seeming to destroy it. He should very much like to know how it happened that the sarcode of the inner sponge seemed to be in such a well-nourished and healthy condition. By means of drawings on the board he pointed out the difficulty of understanding how the process by which the currents of water were drawn into and expelled from the living sponge, by means of which it supplied itself with necessary nourishment, could be carried on if the sponge were entirely invested by the wall of siliceous material. The other slide showing entomostraca inclosed in the sponge was a matter of comparatively common occurrence. It was well known that crustacea were often found inside *Euplectella*, and this was so frequently the case that the Spaniards thought that the *Euplectella* was something which had been spun by the crustacean. In the *Hyalonema* from Japan, the same kind of thing occurred, and they hardly ever obtained specimens

in which the outer portions did not show depressions dotting the surface. These were merely the small holes where the crustacea had lived.

Mr. H. B. Brady communicated to the Society a paper by the Rev. Walter Howchin, of Adelaide, South Australia, "On some additions to the Knowledge of the Carboniferous Foraminifera" (see p. 533). He said that when he was working some years ago on his paper on Carboniferous Foraminifera, Mr. Howchin, then living in England, collected a number of specimens; shortly afterwards his health failed him and he went to Australia, taking with him a large quantity of material to look through and examine. The result was that about a year ago he sent over to England an elaborate paper detailing what he had done. Situated, however, as Mr. Howchin then was, without access to current literature upon the subject, he was not aware of much which had been done since the publication of his (Mr. Brady's) monograph. As it was not possible to present the paper in its then form, he communicated with Mr. Howchin, and was asked in reply to do what was necessary in the way of revision, and then to offer it either to that or some other Society as he might think fit. As he felt deeply grateful to the Royal Microscopical Society for the interest it had taken in the Rhizopods and other subjects, he had great pleasure in presenting the paper to them that evening. It formed a remarkably interesting addition to their knowledge, and was well worthy of a place in their Transactions. The most interesting thing to him was the fact that many of these palæozoic forms were identical with those dredged up by the 'Porcupine' and 'Challenger' expeditions.

Mr. Crisp said that, speaking for their Publication Committee, he could only say they were very pleased to have the paper, and thanked Mr. Brady for handing it over to them. His name was with every microscopist quite a household word, and they were all very glad to have that opportunity of seeing him with them.

Mr. A. Frazer's improved form of microtome for objects imbedded in paraffin was exhibited, the instrument being a modification and extension of the Cathcart microtome.

Mr. J. Mayall, Jun., referring to the new Nelson-Curties Microscope for Photomicrography exhibited in the room, with the differential screw for the fine-adjustment applied under the arm, said that the application of the same thing to the substage, he might point out, was due to Mr. Lombardi. This arrangement for purposes of photography was extremely important, enabling the condenser to be adjusted with great accuracy, without which the high degree of excellence shown in some photographs could never have been obtained.

With regard to the old Microscope before them, if his conjecture as to its age was correct, this instrument would be of great interest as enabling them to claim the so-called "Continental" form of fine-adjustment, which was made upon exactly the same principle.

The Chairman said that in adjourning to October he could only express a hope that during the recess they would be able to collect plenty of matter for the work of the next session, and that when the time came for their next meeting they might have the pleasure of seeing Dr. Hudson again with them. The Library would be closed from the 13th August to the 8th September inclusive.

The following Instruments, Objects, &c., were exhibited :—

Mr. Bolton :—*Notommata brachionus*.

Mr. Cole :—Section of head of Human Embryo, six weeks in utero.  
Eye of Newt, V.T.S.

Mr. Crisp :—Nachet's Crane-arm Microscope. Nachet's Photographic Microscope. Old Microscope with "Continental" fine-adjustment. Klönne and Müller's Focusing arrangement for Photomicrography.

Mr. Curties :—New Nelson-Curties Microscope for Photomicrography.

Mr. Deby :—Slides of a Dipterous Insect. Slides of Myrmecophilous Plants.

Mr. F. Enock :—Slides of Hessian Fly.

Mr. A. Frazer :—Improved Microtome for Objects imbedded in Paraffin.

Dr. P. Yates :—Slides of *Sycon* and *Isodictya*.

---

1888. Part 5.

OCTOBER.

{ To Non-Fellows,  
Price 5s.

JOURNAL  
OF THE  
ROYAL  
MICROSCOPICAL SOCIETY;

CONTAINING ITS TRANSACTIONS AND PROCEEDINGS,

AND A SUMMARY OF CURRENT RESEARCHES RELATING TO

ZOOLOGY AND BOTANY

(principally Invertebrata and Cryptogamia),

MICROSCOPY, &c.

*Edited by*

**FRANK CRISP, LL.B., B.A.,**

*One of the Secretaries of the Society*

*and a Vice-President and Treasurer of the Linnean Society of London;*

WITH THE ASSISTANCE OF THE PUBLICATION COMMITTEE AND

**A. W. BENNETT, M.A., B.Sc., F.L.S.,**

*Lecturer on Botany at St. Thomas's Hospital,*

**F. JEFFREY BELL, M.A., F.Z.S.,**

*Professor of Comparative Anatomy in King's College,*

**JOHN MAYALL, JUN., F.Z.S.,**

**R. G. HEBB, M.A., M.D. (Cantab.),**

AND

**J. ARTHUR THOMSON, M.A.,**

*Lecturer on Zoology in the School of Medicine, Edinburgh,*

FELLOWS OF THE SOCIETY.



WILLIAMS & NORGATE,  
LONDON AND EDINBURGH.

# CONTENTS.

TRANSACTIONS OF THE SOCIETY—

PAGE

IX.—NOTE ON THE REPRODUCTIVE CONDITION OF ORBITOLITES COMPLANATA, VAR. LACINIATA. By Henry B. Brady, F.R.S. (Plate X.) .. .. .	693
X.—NOTICES OF NEW INFUSORIA FLAGELLATA FROM AMERICAN FRESH WATERS. By Alfred C. Stokes, M.D. (Plate XI.) ..	698

## SUMMARY OF CURRENT RESEARCHES.

### ZOOLOGY.

#### A. VERTEBRATA:—Embryology, Histology, and General.

##### a. Embryology.

WEISMAN, A., & C. ISCHIKAWA— <i>Formation of Polar Globules in Animal Ova</i> ..	705
HOFFMANN, C. K.— <i>Origin and Significance of the so-called free Nuclei in the Nutrient Yolk of Bony Fishes</i> .. .. .	706
RYDER, J. A.— <i>Resemblance of Ovarian Ova and the Primitive Foraminifera</i> ..	705
BIHRINGER, J.— <i>Inversion of the Germinal Layers in the Shrew</i> .. .. .	706
EBNER, V. v., & E. SERTOLI— <i>Spermatogenesis of Mammals</i> .. .. .	707
SANFELICE, F.— <i>Spermatogenesis in Guinea-pig</i> .. .. .	707
MASSART, J.— <i>Irritability of Spermatozoa of Frog</i> .. .. .	707
HOUSSAY, F., & BATAILLON— <i>Development of the Axolotl</i> .. .. .	707
KUPFFER, C.— <i>Development of the Lamprey</i> .. .. .	708
WEISMANN, A., & C. ISCHIKAWA— <i>Partial Impregnation</i> .. .. .	709
HERTWIG'S (O.) ' <i>Human and Vertebrate Embryology</i> ' .. .. .	710

##### b. Histology.

LEYDIG, F.— <i>Cells and Tissues</i> .. .. .	710
ARNOLD, J.— <i>Cell-division</i> .. .. .	712
IDE, M.— <i>Cell-membrane</i> .. .. .	712
STEINHAUS, J.— <i>Goblet-cells of Intestine of Salamander</i> .. .. .	712
FLEISCH, M.— <i>Micro-chemistry of Nerve-cells</i> .. .. .	712
JANOSIK, J.— <i>Histology of the Ovary</i> .. .. .	713

##### γ. General.

LOEB, J.— <i>Influence of Light on Oxidation</i> .. .. .	714
--	-----

#### B. INVERTEBRATA.

GRIFFITHS, A. B.— <i>Problematical Organs of the Invertebrata</i> .. .. .	714
FOL, H.— <i>Distribution of Striped Muscle</i> .. .. .	714

##### Mollusca.

##### γ. Gastropoda.

PERRIER, R.— <i>Comparative Histology of Glandular Epithelium of Kidney of Prosobranch Gastropods</i> .. .. .	715
HANITSCH, R.— <i>Anatomy and Histology of Limax agrestis</i> .. .. .	716
GARNAULT, P.— <i>Anatomy and Histology of Cyclostoma elegans</i> .. .. .	716
PETIT, L.— <i>Effects of Lesion of Supra-oesophageal Ganglia in Snails</i> .. .. .	717
WILLEM, V.— <i>Creeping Movements</i> .. .. .	718
VATSIÈRE, A.— <i>Systematic Position of Hero</i> .. .. .	718
GARNAULT, F.— <i>Anatomy of Valvata piscinalis</i> .. .. .	718

##### δ. Lamellibranchiata.

GROBEN, C.— <i>Pericardial Gland</i> .. .. .	720
--	-----

##### Molluscoida.

##### β. Bryozoa.

HARMER, S. F.— <i>Embryogeny of Ectoproctous Bryozoa</i> .. .. .	721
--	-----

	PAGE
<b>Arthropoda.</b>	
<b>a. Insecta.</b>	
KORSCHULT, E.— <i>Egg-membranes of Insects</i> .. .. .	722
RULAND, F.— <i>Antennary Sensory Organs of Insects</i> .. .. .	723
CARLET, G.— <i>Poison of Hymenoptera</i> .. .. .	724
COOK, A. J.— <i>Morphology of the Legs of Hymenoptera</i> .. .. .	725
HOFER, BRUNO— <i>Salivary Glands of Cockroach</i> .. .. .	725
TICHOMIROFF, A.— <i>Parthenogenesis in Bombyx mori</i> .. .. .	725
LUCIANI, L., & A. PIUTTI— <i>Respiration of Silk-worm Ova</i> .. .. .	726
CARLET, G.— <i>Mode of Locomotion of Caterpillars</i> .. .. .	726
WHITE, W.— <i>Colour-relation between Pupæ and Surroundings</i> .. .. .	727
KESSLER, H. F.— <i>Aphides</i> .. .. .	727
<b>B. Myriopoda.</b>	
HEATHCOTE, F. G.— <i>Post-embryonic Development of Julus terrestris</i> .. .. .	727
<b>δ. Arachnida.</b>	
WINKLER, W.— <i>Anatomy of Gamasidæ</i> .. .. .	729
<b>ε. Crustacea.</b>	
CATTANEO, G.— <i>Intestine and Digestive Glands of Decapods</i> .. .. .	729
PETIT, L.— <i>Effects of Lesions of the Supra-œsophageal Ganglia of the Crab (Carcinus Menas)</i> .. .. .	730
BERGENDAL, D.— <i>Male Appendages on Females</i> .. .. .	730
BEDDARD, F. E.— <i>Eyes of Cymothoidæ</i> .. .. .	730
GIARD, A., & J. BONNIER— <i>New Species of Ceponinæ</i> .. .. .	731
GUERNE, J. DE, & J. RICHARD— <i>Geographical Distribution of Diaptomus</i> .. .. .	731
SCHWARZ, C. G.— <i>So-called Mucous Gland of Male Cypridæ</i> .. .. .	731
<b>Vermes.</b>	
<b>a. Annelida.</b>	
COLLIN, A.— <i>Criodrilus lacuum</i> .. .. .	733
ROULE, L.— <i>Formation of Embryonic Layers and Cœlom of a Limicolous Oligochaete</i>	735
CUNNINGHAM, J. T.— <i>Nephridia of Lanice conchilega</i> .. .. .	735
MICHAELSEN, W.— <i>New Enchytræidæ</i> .. .. .	736
<b>β. Nemathelminthes.</b>	
KULTSCHITZKY, N.— <i>Fertilization of Ascaris</i> .. .. .	736
CAMERANO, L.— <i>Structure and Position of Gordiaceæ</i> .. .. .	737
STRUBELL, A.— <i>Structure and Development of Heterodera Schachtii</i> .. .. .	737
CHATIN, J.— <i>Integument of Heterodera Schachtii</i> .. .. .	738
GRASSI, B., & S. CALANDRUCCIO— <i>Echinorhynchus parasitic in Man, and whose intermediary host is a Blaps</i> .. .. .	739
SEIFERT, O.— <i>Ankylostomum duodenale</i> .. .. .	739
WALSINGHAM— <i>Gape Worm of Fowls</i> .. .. .	740
<b>δ. Incertæ Sedis.</b>	
GUERNE, J. DE— <i>Asplanchnidæ</i> .. .. .	740
<b>Echinodermata.</b>	
JICKELI, C. F.— <i>Nervous System of Echinodermata</i> .. .. .	741
<b>Cœlenterata.</b>	
HAECKEL, E.— <i>System of Siphonophora</i> .. .. .	741
BROOKS, W. K.— <i>Life-history of Epenthesis McCradyi, n. sp.</i> .. .. .	743
VOGT, C.— <i>Arachnactis and Cerianthus</i> .. .. .	743
VIGUIER, C.— <i>New Type of Anthozoa</i> .. .. .	745
MILNES MARSHALL, A., & G. H. FOWLER— <i>'Porcupine' Pennatulida</i> .. .. .	745
<b>Porifera.</b>	
NOLL, F. C.— <i>Natural History of Siliceous Sponges</i> .. .. .	745
SCHULZE, F. E.— <i>'Challenger' Hexactinellida</i> .. .. .	747
WIERZEJSKI, A.— <i>Fresh-water Sponges</i> .. .. .	748
HINDE, G. J.— <i>New Species of Uruguaya</i> .. .. .	748

	PAGE
<b>Protozoa.</b>	
KUNSTLER, J.— <i>Vesicular Elements of Protoplasm in Protozoa</i> .. .. .	748
MEISSNER, M.— <i>Physiology of Nutrition in Protozoa</i> .. .. .	749
BREYNE, C. DE.— <i>Nature of Contractile Vacuole</i> .. .. .	749
GRUBER, A.— <i>Further Observations on Multinuclear Infusoria</i> .. .. .	750
FABRE-DOMERGUE— <i>Researches on Ciliated Infusoria</i> .. .. .	751
MAUPAS, E.— <i>Conjugation of Vorticellidæ</i> .. .. .	752
FABRE-DOMERGUE— <i>Structure of Urccolariæ</i> .. .. .	753
FANKHAUSER, J.— <i>Euglena</i> .. .. .	754
DANGEARD, P. A.— <i>Cryptomonadineæ</i> .. .. .	754
GOERRET, P., & P. ROESER— <i>Protozoa of Corsica</i> .. .. .	755
VERWORN, M.— <i>Biological Studies on Protista</i> .. .. .	755
GRUBER, A.— <i>New Rhizopods</i> .. .. .	757
CARTER, H. J.— <i>Observations on Parkeria</i> .. .. .	757
SHERBORN'S (C. D.) <i>Bibliography of the Foraminifera</i> .. .. .	757

## BOTANY.

### A. GENERAL, including the Anatomy and Physiology of the Phanerogamia.

#### a. Anatomy.

##### (1) Cell-structure and Protoplasm.

BOKORNY, T.— <i>Action of basic substances on living Protoplasm</i> .. .. .	758
ERRERA, L.— <i>Forms of Cells</i> .. .. .	758
KLEBS, G.— <i>Physiology of the Cell</i> .. .. .	758
WIELER, A.— <i>Plasmolysis in Flowering Plants</i> .. .. .	759

##### (2) Other Cell-contents (including Secretions).

MICHAUD, G.— <i>Alkaloid and Sugar in Cyclamen</i> .. .. .	759
HECKEL, E., & F. SCHLAGDENHAUFFEN— <i>Laticiferous product of <i>Minusops</i> and <i>Payena</i></i> .. .. .	759
ACTON, E. H.— <i>Formation of Sugars in the Septal Glands of <i>Narcissus</i></i> .. .. .	759
TSCHIRCH, A.— <i>Contents of the Cells of the Aril of the Nutmeg</i> .. .. .	760
BERTHELOT, & G. ANDRÉ— <i>Phosphorus and Phosphoric Acid in Plants</i> .. .. .	760

##### (3) Structure of Tissues.

TRIEBEL, R.— <i>Oil-receptacles in the Roots of Composite</i> .. .. .	760
DOULIOT, H.— <i>Formation of Periderm</i> .. .. .	761
PRAËL, E.— <i>Protecting-wood and Duramen</i> .. .. .	761
MER, E.— <i>Causes which produce Eccentricity of the Pith in Pines</i> .. .. .	761
„ „ <i>Influence of Exposure on the Formation of the Annual Rings in the Savin</i> .. .. .	762
COMES, O.— <i>Mal nero of the Vine</i> .. .. .	762

##### (4) Structure of Organs.

BORZÌ, A.— <i>Formation of Lateral Roots in Monocotyledones</i> .. .. .	762
MANGIN, L.— <i>Permeability of the Epidermis of Leaves for Gases</i> .. .. .	763
SCHAEFER, R.— <i>Influence of the Turgidity of the Epidermal Cells on the Stomata</i> .. .. .	763
MITTMANN, R.— <i>Anatomy of Spines</i> .. .. .	763
HOVELACQUE, M.— <i>Propagula of <i>Pinguicula</i></i> .. .. .	764
PFITZER, E.— <i>Flower of <i>Orchidæ</i></i> .. .. .	764
CALLONI, S.— <i>Ovules of <i>Rumex</i></i> .. .. .	764
HYRANO, K.— <i>Seeds of <i>Pharbitis triloba</i></i> .. .. .	764
HEINRICHER, E.— <i>Structure of <i>Impatiens</i></i> .. .. .	764
DENNERT, E.— <i>Anatomy of <i>Nelumbium</i></i> .. .. .	765

#### b. Physiology.

##### (1) Reproduction and Germination.

HEGELMAIER, F.— <i>Formation of Endosperm in Dicotyledons</i> .. .. .	765
MARILAUN, A. K. v.— <i>Fertilization of <i>Euphrasia</i></i> .. .. .	767
DAMMER, U.— <i>Adaptation of the Flowers of <i>Eremurus altaicus</i> to Cross-fertilization</i> .. .. .	767
LEWIN, M.— <i>Germination of Monocotyledons</i> .. .. .	767
MENOZZI, A.— <i>Chemistry of Germination</i> .. .. .	767

##### (2) Nutrition and Growth (including Movements of Fluids).

KREUSLER, U.— <i>Assimilation and Expiration of Plants</i> .. .. .	768
HILDEBRAND, F.— <i>Production of Vegetative from Fertile Shoots of <i>Opuntia</i></i> .. .. .	768
HUNGER, E. H.— <i>Viviparous Plants and Apogamy</i> .. .. .	768

	PAGE
WIELER, A.— <i>Conduction of Sap through the Secondary Wood</i> .. .. .	768
BALLAND— <i>Development of Wheat</i> .. .. .	769
CLARKE, C. B.— <i>Root-pressure</i> .. .. .	769
ELVING, F.— <i>Curvature of Plants</i> .. .. .	769
GRIFFITHS, A. B., & MRS. GRIFFITHS— <i>Influence of certain Rays of the Solar Spectrum on Root-absorption and on the Growth of Plants</i> .. .. .	769
HEBRIEGEL, & WILLFARTH— <i>Absorption of Nitrogen by Plants</i> .. .. .	770

## (3) Irritability.

BATESON, A., & F. DARWIN— <i>Method of Studying Geotropism</i> .. .. .	770
PFEFFER, W.— <i>Chemotactic Movements of Bacteria, Flagellata, and Volvocineæ</i> .. .. .	770

## (4) Chemical Changes (including Respiration and Fermentation).

RODEWALD, H.— <i>Changes of Substance and Force connected with Respiration</i> .. .. .	771
BOKORNY, T.— <i>Formation of Starch from various substances</i> .. .. .	771

## γ. General.

SCHIMPER, A. F. W.— <i>Relationship between Insects and Plants in the Tropics</i> .. .. .	772
PRINGSHEIM, N.— <i>Deposition of Calcareous Incrustations on Fresh-water Plants</i> .. .. .	773
BRENSTEIN, G.— <i>Action of Ether on Plant-life</i> .. .. .	773

## B. CRYPTOGAMIA.

## Cryptogamia Vascularia.

VINES, S. H.— <i>Systematic Position of Isoetes</i> .. .. .	773
VAIZEY, J. R.— <i>Development of the Root of Equisetum</i> .. .. .	773

## Muscineæ.

SCHNETZLER, J. B.— <i>Reproduction of Thamnum alopecurum</i> .. .. .	773
NOLL, F.— <i>Protonema of Schistostega osmundacea</i> .. .. .	774
RUSSOW, E.— <i>Physiological and Comparative Anatomy of Sphagnaceæ</i> .. .. .	774
RÖLL— <i>Forms of Sphagnum</i> .. .. .	775

## Algæ.

TONI, J. B. DE— <i>Classification of Chlorophyceæ</i> .. .. .	775
HANSGERG, A.— <i>Classification of Conservoideæ</i> .. .. .	775
BORNET, E., & C. FLAHAULT— <i>New Genera of Perforating Algæ</i> .. .. .	776
WILDEMAN, E. DE— <i>Ulothrix and Stichococcus</i> .. .. .	777
" " " <i>Trentepohlia</i> .. .. .	777
TONI, G. B. DE— <i>Diatoms from a Trygon</i> .. .. .	777

## Fungi.

PHILLIPS, W.— <i>Luminosity of Fungi</i> .. .. .	777
BOUDIER— <i>Conidiferous Form of Polyporus biennis</i> .. .. .	778
BREFFELD, O.— <i>Classification of Basidiomycetes</i> .. .. .	778
PATOUILLARD, N.— <i>New Tubercularia</i> .. .. .	779
MASSEE, G.— <i>Calostoma Desv. (Mitremyces Nees)</i> .. .. .	780
GROVES, W. B.— <i>Pimina, a new Genus of Hyphomycetes</i> .. .. .	780
THÜMEN, F. v.— <i>Fungi of Fruit-trees</i> .. .. .	780
BONNET, H.— <i>Parasitism of the Truffle</i> .. .. .	780
SEYNES, J. DE— <i>Fungus Parasitic on the Pine-apple</i> .. .. .	780
BRUNCHORST, J.— <i>Fungus Parasitic on the Salt-fish</i> .. .. .	781
BARTET & VUILLEMIN— <i>"Rouge" of the Scotch Fir</i> .. .. .	781
DANGEARD, A.— <i>Parasites of the Peridiniæ</i> .. .. .	781
VUILLEMIN, P.— <i>Disease attacking Amygdalæ</i> .. .. .	781
ZOPF, W.— <i>Haplococcus reticulatus</i> .. .. .	782
LAGERHEIM, G.— <i>New Puccinia</i> .. .. .	782
MASSEE, G.— <i>Sexual Organs in Æcidium</i> .. .. .	782
GIARD, A.— <i>Symbiotic Fungus in Molgulidæ</i> .. .. .	782
LISTER, A.— <i>Plasmodium of Badhamia and Brefeldia</i> .. .. .	783
DANGEARD, P. A.— <i>Mycological Notes</i> .. .. .	783

## Protophyta.

GOMONT, M.— <i>Relationship between Phormidium and Lyngbya</i> .. .. .	784
MACÉ, E.— <i>Cultures of Cladothrix dichotoma</i> .. .. .	784
LAGERHEIM, G.— <i>New Pleurocapsa</i> .. .. .	784
SCHNETZLER, J. B.— <i>Colouring matter of the waters of the Lake of Bret</i> .. .. .	785
JACQUEMIN, G.— <i>Saccharomyces ellipsoideus and its Use in the Preparation of Wine from Barley</i> .. .. .	785

	PAGE
LAURENT, E.—Organic nourishment of Beer-ferment .. .. .	785
ERMENGEN, E. VAN—Scheuerlen's Cancer Bacillus .. .. .	785
WINOGRADSKY, S.—Iron-bacteria .. .. .	786
TOMASCHKE, A., & A. HANSGIRG— <i>Bacillus muralis</i> .. .. .	786
PRAZMOWSKI, A.—Spore-formation in Bacteria .. .. .	787
BILLET, A.—New Marine Bacterium .. .. .	789
FRANKLAND, GRACE C., & PERCY F. FRANKLAND—New and Typical Micro-organisms from Water and Soil .. .. .	789
BAUMGARTEN'S Pathological Mycology .. .. .	791

## MICROSCOPY.

### a. Instruments, Accessories, &c.

#### (1) Stands.

THURY'S Five-tube Microscope (Fig. 120) .. .. .	792
SCHIECK'S (F. W.) Meat-examining Microscope (Fig. 121) .. .. .	793
"    Travelling Microscope (Fig. 122) .. .. .	794
ZEISS'S IIa Microscope—Bubuchin's Microscope .. .. .	794
LEITZ'S Demonstration Microscope—Old Demonstration Microscope (Figs. 123 and 124) .. .. .	794
WHITE, S. S.—Dentist's Examining Glass (Fig. 125) .. .. .	795
BAUSCH AND LOMB OPTICAL CO.'S "Watchmaker Glass" (Fig. 126) .. .. .	795
GANZ'S (J.) Pinakoscope with Dreyfus's Reflector (Fig. 127) .. .. .	796
TRI-OCULAR, Quadri-ocular, &c., Prisms (Figs. 128-132) .. .. .	796

#### (2) Eye-pieces and Objectives.

ZEISS'S "Compensation Eye-piece 6 with 1/1 Micron-division" (Fig. 133) .. .. .	797
--	-----

#### (3) Illuminating and other Apparatus.

ETERNOD'S (A.) Drawing-board (Figs. 134-139) .. .. .	798
BABES' (V.) Hot Stage (Figs. 140 and 141) .. .. .	800
CHABRY, L.—Capillary Slide and accessories for the examination of Ora (Figs. 142 and 143) .. .. .	801
BEEBE, F.—Measuring Corrosion Surfaces in Iron Pyrites (Fig. 144) .. .. .	803
ROWLAND'S (W.) Reversible Compressorium (Fig. 145) .. .. .	803
BEAUMONT'S (C. R.) Reservoir Life-slide (Figs. 146 and 147) .. .. .	804
HOLMAN'S Current Slide .. .. .	806
STOKES, A. C.—Life Slides .. .. .	806
LAMPS for Microscopical Work .. .. .	807
MALASSEZ, L.—Tubes for Microspectroscopic Analysis (Fig. 148) .. .. .	807

#### (4) Photomicrography.

BURSTERT'S (H.) Photomicrographic Apparatus (Fig. 149) .. .. .	808
NEUBAUSS'S (R.) Focusing Arrangement (Fig. 150) .. .. .	809
PIERSON, G. A.—Drawings v. Photographs.—Screen for the Abbe Camera Lucida .. .. .	809
STENGLIN, M.—Instantaneous Photomicrography .. .. .	811
ERRERA, L.—Photographing moving Microscopic Objects .. .. .	812
FISCHER—Photographing phosphorescent bacilli by means of their own light .. .. .	813

#### (5) Microscopical Optics and Manipulation.

FASOLDT, C.—Variation in Micrometric Measurements due to different illumination .. .. .	814
REINHERTZ—Testing Screw-Micrometers of Reading-Microscopes .. .. .	814
SMITH, T. F.—Arachnoidiscus as a new Test for High-power Objectives .. .. .	815
NELSON, E. M.—Tests for Modern Objectives .. .. .	816
FASOLDT'S (C.) Test-plates .. .. .	817
MICROSCOPICAL Optics and the Quekett Club Journal .. .. .	817

#### (6) Miscellaneous.

QUINN, E. P.—Simple method of Projecting upon the screen Microscopic Rock Sections, both by ordinary and by polarized light .. .. .	819
JUDD, J. W.—Microscopy and the Study of Rocks .. .. .	820
HOUZEAU, J. C.—Microscope and Telescope .. .. .	820

## B. Technique.

### (1) Collecting Objects, including Culture Processes.

BIRCH-HIRSCHFELD—Cultivation of Schizomyces in Coloured Nutritive Media .. .. .	823
FRÄNKEL, C.—Cultivation of Anaerobic Micro-organisms .. .. .	824
GLOBIG—Bacterial Growth between 50° and 70° C. .. .. .	824

	PAGE
ROSENTHAL, J., & O. SCHULZ— <i>Alkali-Albuminate as a Nutrient Medium</i> .. .. .	825
CHEESMAN, T. L., JUN.— <i>Preparation of Nutrient Gelatin and Agar</i> .. .. .	825
HÜPPE, F.— <i>Eggs for Cultivation purposes</i> .. .. .	827
ROUX— <i>Cultivation on Potato</i> .. .. .	827
GIAXA, DE— <i>Simple Method for reproducing Koch's Cultivation Plates</i> .. .. .	827
BABES' (V.) <i>modified Cultivation Vessel (Fig. 151)</i> .. .. .	828
PFEIFER, A.— <i>Cooler for quickly setting Gelatin Plates</i> .. .. .	828
ALLEN, T. F.— <i>Collecting and Preparing Characæ</i> .. .. .	828
MÖLLER, A.— <i>Cultivation of Lichen-forming Ascomycetes without Algæ</i> .. .. .	829
DIAKONOW, N. W.— <i>Apparatus for Injecting (Fig. 152)</i> .. .. .	829
(2) Preparing Objects.	
TRZEBINSKI, S.— <i>Effect of Hardening Agents on the Ganglion-cells of the Spinal Cord</i> .. .. .	831
DIOMIDOFF, A.— <i>Sublimate as a Hardening Medium for the Brain</i> .. .. .	831
HÜPPE, A.— <i>Preparation of Criodrilus lacuum</i> .. .. .	832
KÜNSTLER, J.— <i>Method of Preparing Tegumentary Filaments of Flagellata</i> .. .. .	832
FISCHL, R.— <i>New Method for making Microscopical Preparations from Test-tube Cultivations</i> .. .. .	833
MORGAN, T. H.— <i>Chitin Solvents</i> .. .. .	833
WHELPLEY, H. M.— <i>Preparing Slides to show Brownian Movement</i> .. .. .	833
(3) Cutting, including Imbedding.	
KRYSINSKI— <i>Photoxylin for Imbedding</i> .. .. .	834
CAMPBELL, D. H.— <i>Paraffin-imbedding Process in Botany</i> .. .. .	834
APÁTHY, S.— <i>Further Notes on Colloidin Technique</i> .. .. .	836
BRUCE'S (A.) <i>Microtome for cutting whole sections of the Brain and other organs (Figs. 153 and 154)</i> .. .. .	837
THATÉ'S (P.) <i>New Microtome (Fig. 155)</i> .. .. .	839
ERDŐS, J.— <i>Accessory for rapid cutting with the Thoma Microtome (Fig. 156)</i> .. .. .	840
STRASSER, H.— <i>New Section-stretcher, with arrangements for removing the Section</i> .. .. .	841
(4) Staining and Injecting.	
GRAY, W. M.— <i>Double-staining of Nucleated Blood-corpuscles</i> .. .. .	842
SCHULTZE, O.— <i>Vital Methylene-blue Reaction of Cell-granules</i> .. .. .	842
PILLET, A.— <i>Differential Staining of the Tissues of Living Animals</i> .. .. .	842
ROTTERER, E.— <i>Staining-differences of Unstriped Muscle and Connective Tissue Fibres</i> .. .. .	843
MARTINOTTI, C.— <i>Improvements in the Silver-nitrate Method for Staining Nervous Tissue</i> .. .. .	844
SCHÄFFER, J.— <i>Staining in the Study of Bone Development</i> .. .. .	844
PRENANT, A.— <i>Preparing and Staining Mammalian Testicle</i> .. .. .	844
JAMES, F. L.— <i>Stain for the Morphological Elements in Urine</i> .. .. .	845
HAUSER, G.— <i>Staining Spores</i> .. .. .	845
LÜBIMOFF, N.— <i>Staining Tubercle and Leprosy Bacilli</i> .. .. .	846
CUCCATI, G.— <i>Alcoholic Solution of Hamatoxylin</i> .. .. .	846
KOLOSSOW, A.— <i>Osmic Acid and Gold chloride Methods</i> .. .. .	846
AIEVOLI, E.— <i>Phenol in Microscopical Technique</i> .. .. .	847
LIST, J. H.— <i>Double Staining</i> .. .. .	847
JACOBI, E.— <i>Hardening and Staining Plate-cultivations</i> .. .. .	848
HOYER, H.— <i>Injection Mass for the Vessels of the Spleen</i> .. .. .	848
TAGUCHI, K.— <i>Injection with Indian Ink</i> .. .. .	848
FLESCHE, M.— <i>Beck's Microsyringe (Fig. 157)</i> .. .. .	849
(5) Mounting, including Slides, Preservative Fluids, &c.	
ZABRISKIE, J. L.— <i>Continuous Centering of a Cover-glass</i> .. .. .	850
STEINACH'S (E.) <i>Filter-capsule (Figs. 158 and 159)</i> .. .. .	850
KRONFELD, M.— <i>Apparatus for inclosing microscopical preparations of botanical objects mounted in glycerin (Fig. 160)</i> .. .. .	851
VRIES, H. DE— <i>Preservation of Plants in Spirit and the Prevention of Browning</i> .. .. .	852
NELSON, J.— <i>Fixing Sections to the Slide</i> .. .. .	853
(6) Miscellaneous.	
STRASSER, H.— <i>Methods of Plastic Reconstruction</i> .. .. .	853
RAFTER, G. W.— <i>Making Mounts Photographic</i> .. .. .	854
MAYR— <i>Improved method for Enumerating Blood-corpuscles</i> .. .. .	854
STRAUS & WURTZ— <i>Improved method for the Bacteriological Examination of Air</i> .. .. .	854
SMART, C.— <i>Gelatin Culture Test for Micro-organisms of Water</i> .. .. .	855
ILLUSTRATIONS of Pond Life .. .. .	855
PROCEEDINGS OF THE SOCIETY .. .. .	857

I.—APERTURE TABLE.

Numerical Aperture. ( $n \sin u = a$ )	Corresponding Angle ( $2u$ ) for			Limit of Resolving Power, in Lines to an Inch.			Illuminating Power. ( $a^2$ .)	Penetrating Power. ( $\frac{1}{a}$ )
	Air ( $n = 1.00$ ).	Water ( $n = 1.33$ ).	Homogeneous Immersion ( $n = 1.52$ ).	White Light. ( $\lambda = 0.5269 \mu$ , Line E.)	Monochromatic (Blue) Light. ( $\lambda = 0.4861 \mu$ , Line F.)	Photography. ( $\lambda = 0.4000 \mu$ , near Line h.)		
1.52	..	..	180° 0'	146,543	158,845	193,037	2.310	.658
1.51	..	..	166° 51'	145,579	157,800	191,767	2.280	.662
1.50	..	..	161° 23'	144,615	156,755	190,497	2.250	.667
1.49	..	..	157° 12'	143,651	155,710	189,227	2.220	.671
1.48	..	..	153° 39'	142,687	154,665	187,957	2.190	.676
1.47	..	..	150° 32'	141,723	153,620	186,687	2.161	.680
1.46	..	..	147° 42'	140,759	152,575	185,417	2.132	.685
1.45	..	..	145° 6'	139,795	151,530	184,147	2.103	.690
1.44	..	..	142° 39'	138,830	150,485	182,877	2.074	.694
1.43	..	..	140° 22'	137,866	149,440	181,607	2.045	.699
1.42	..	..	138° 12'	136,902	148,395	180,337	2.016	.704
1.41	..	..	136° 8'	135,938	147,350	179,067	1.988	.709
1.40	..	..	134° 10'	134,974	146,305	177,797	1.960	.714
1.39	..	..	132° 16'	134,010	145,260	176,527	1.932	.719
1.38	..	..	130° 26'	133,046	144,215	175,257	1.904	.725
1.37	..	..	128° 40'	132,082	143,170	173,987	1.877	.730
1.36	..	..	126° 58'	131,118	142,125	172,717	1.850	.735
1.35	..	..	125° 18'	130,154	141,080	171,447	1.823	.746
1.34	..	..	123° 40'	129,189	140,035	170,177	1.796	.741
1.33	..	180° 0'	122° 6'	128,225	138,989	168,907	1.769	.752
1.32	..	165° 56'	120° 33'	127,261	137,944	167,637	1.742	.758
1.31	..	160° 6'	119° 3'	126,297	136,899	166,367	1.716	.763
1.30	..	155° 38'	117° 35'	125,333	135,854	165,097	1.690	.769
1.29	..	151° 50'	116° 8'	124,369	134,809	163,827	1.664	.775
1.28	..	148° 42'	114° 44'	123,405	133,764	162,557	1.638	.781
1.27	..	145° 27'	113° 21'	122,441	132,719	161,287	1.613	.787
1.26	..	142° 39'	111° 59'	121,477	131,674	160,017	1.588	.794
1.25	..	140° 3'	110° 39'	120,513	130,629	158,747	1.563	.800
1.24	..	137° 36'	109° 20'	119,548	129,584	157,477	1.538	.806
1.23	..	135° 17'	108° 2'	118,584	128,539	156,207	1.513	.813
1.22	..	133° 4'	106° 45'	117,620	127,494	154,937	1.488	.820
1.21	..	130° 57'	105° 30'	116,656	126,449	153,668	1.464	.826
1.20	..	128° 55'	104° 15'	115,692	125,404	152,397	1.440	.833
1.19	..	126° 58'	103° 2'	114,728	124,359	151,128	1.416	.840
1.18	..	125° 3'	101° 50'	113,764	123,314	149,857	1.392	.847
1.17	..	123° 13'	100° 38'	112,799	122,269	148,588	1.369	.855
1.16	..	121° 26'	99° 29'	111,835	121,224	147,317	1.346	.862
1.15	..	119° 41'	98° 20'	110,872	120,179	146,048	1.323	.870
1.14	..	118° 0'	97° 11'	109,907	119,134	144,777	1.300	.877
1.13	..	116° 20'	96° 2'	108,943	118,089	143,508	1.277	.885
1.12	..	114° 44'	94° 55'	107,979	117,044	142,237	1.254	.893
1.11	..	113° 9'	93° 47'	107,015	115,999	140,968	1.232	.901
1.10	..	111° 36'	92° 43'	106,051	114,954	139,698	1.210	.909
1.09	..	110° 5'	91° 38'	105,087	113,909	138,428	1.188	.917
1.08	..	108° 36'	90° 34'	104,123	112,864	137,158	1.166	.926
1.07	..	107° 8'	89° 30'	103,159	111,819	135,888	1.145	.935
1.06	..	105° 42'	88° 27'	102,195	110,774	134,618	1.124	.943
1.05	..	104° 16'	87° 24'	101,231	109,729	133,348	1.103	.952
1.04	..	102° 53'	86° 21'	100,266	108,684	132,078	1.082	.962
1.03	..	101° 30'	85° 19'	99,302	107,639	130,808	1.061	.971
1.02	..	100° 10'	84° 18'	98,338	106,593	129,538	1.040	.980
1.01	..	98° 50'	83° 17'	97,374	105,548	128,268	1.020	.990
1.00	180° 0'	97° 31'	82° 17'	96,410	104,503	126,998	1.000	1.000
0.99	163° 48'	96° 12'	81° 17'	95,446	103,458	125,728	.980	1.010
0.98	157° 2'	94° 56'	80° 17'	94,482	102,413	124,458	.960	1.020
0.97	151° 52'	93° 40'	79° 18'	93,518	101,368	123,188	.941	1.031
0.96	147° 29'	92° 24'	78° 20'	92,554	100,323	121,918	.922	1.042
0.95	143° 36'	91° 10'	77° 22'	91,590	99,278	120,648	.903	1.053
0.94	140° 6'	89° 56'	76° 24'	90,625	98,233	119,378	.884	1.064
0.93	136° 52'	88° 44'	75° 27'	89,661	97,188	118,108	.865	1.075
0.92	133° 51'	87° 32'	74° 30'	88,697	96,143	116,838	.846	1.087
0.91	131° 0'	86° 20'	73° 33'	87,733	95,098	115,568	.828	1.099
0.90	128° 19'	85° 10'	72° 36'	86,769	94,053	114,298	.810	1.111
0.89	125° 45'	84° 0'	71° 40'	85,805	93,008	113,028	.792	1.124
0.88	123° 17'	82° 51'	70° 44'	84,841	91,963	111,758	.774	1.136

APERTURE TABLE—continued.

Numerical Aperture. ( $n \sin u = a$ .)	Corresponding Angle ( $2u$ ) for			Limit of Resolving Power, in Lines to an Inch.			Illuminating Power, ( $a^2$ .)	Penetrating Power, ( $\frac{1}{a}$ )
	<i>Air</i> ( $n = 1.00$ .)	<i>Water</i> ( $n = 1.33$ .)	<i>Homogeneous Immersion</i> ( $n = 1.52$ .)	White Light. ( $\lambda = 0.5269 \mu$ , Line E.)	Monochromatic (Blue) Light. ( $\lambda = 0.4861 \mu$ , Line F.)	Photography. ( $\lambda = 0.4000 \mu$ , near Line h.)		
0.87	120° 55'	81° 42'	69° 49'	83,877	90,918	110,488	.757	1.149
0.86	118° 38'	80° 34'	68° 54'	82,913	89,873	109,218	.740	1.163
0.85	116° 25'	79° 37'	68° 0'	81,949	88,828	107,948	.723	1.176
0.84	114° 17'	78° 20'	67° 6'	80,984	87,783	106,678	.706	1.190
0.83	112° 12'	77° 14'	66° 12'	80,020	86,738	105,408	.689	1.205
0.82	110° 10'	76° 8'	65° 18'	79,056	85,693	104,138	.672	1.220
0.81	108° 10'	75° 3'	64° 24'	78,092	84,648	102,868	.656	1.235
0.80	106° 16'	73° 58'	63° 31'	77,128	83,603	101,598	.640	1.250
0.79	104° 22'	72° 53'	62° 38'	76,164	82,558	100,328	.624	1.266
0.78	102° 31'	71° 49'	61° 45'	75,200	81,513	99,058	.608	1.282
0.77	100° 42'	70° 45'	60° 52'	74,236	80,468	97,788	.593	1.299
0.76	98° 56'	69° 42'	60° 0'	73,272	79,423	96,518	.578	1.316
0.75	97° 11'	68° 40'	59° 8'	72,308	78,378	95,248	.563	1.333
0.74	95° 28'	67° 37'	58° 16'	71,344	77,333	93,979	.548	1.351
0.73	93° 46'	66° 34'	57° 24'	70,379	76,288	92,709	.533	1.370
0.72	92° 6'	65° 32'	56° 32'	69,415	75,242	91,439	.518	1.389
0.71	90° 28'	64° 32'	55° 41'	68,451	74,197	90,169	.504	1.408
0.70	88° 51'	63° 31'	54° 50'	67,487	73,152	88,899	.490	1.429
0.69	87° 16'	62° 30'	53° 59'	66,523	72,107	87,629	.476	1.449
0.68	85° 41'	61° 30'	53° 9'	65,559	71,062	86,359	.462	1.471
0.67	84° 8'	60° 30'	52° 18'	64,595	70,017	85,089	.449	1.493
0.66	82° 36'	59° 30'	51° 28'	63,631	68,972	83,819	.436	1.515
0.65	81° 6'	58° 30'	50° 38'	62,667	67,927	82,549	.423	1.538
0.64	79° 36'	57° 31'	49° 48'	61,702	66,882	81,279	.410	1.562
0.63	78° 6'	56° 32'	48° 58'	60,738	65,837	80,009	.397	1.587
0.62	76° 38'	55° 34'	48° 9'	59,774	64,792	78,739	.384	1.613
0.61	75° 10'	54° 36'	47° 19'	58,810	63,747	77,469	.372	1.639
0.60	73° 44'	53° 38'	46° 30'	57,846	62,702	76,199	.360	1.667
0.59	72° 18'	52° 40'	45° 40'	56,881	61,657	74,929	.348	1.695
0.58	70° 54'	51° 42'	44° 51'	55,915	60,612	73,659	.336	1.724
0.57	69° 30'	50° 45'	44° 2'	54,954	59,567	72,389	.325	1.754
0.56	68° 6'	49° 48'	43° 14'	53,990	58,522	71,119	.314	1.786
0.55	66° 44'	49° 51'	42° 25'	53,026	57,477	69,849	.303	1.818
0.54	65° 22'	47° 54'	41° 37'	52,061	56,432	68,579	.292	1.852
0.53	64° 0'	46° 58'	40° 48'	51,097	55,387	67,309	.281	1.887
0.52	62° 40'	46° 2'	40° 0'	50,133	54,342	66,039	.270	1.923
0.51	61° 20'	45° 6'	39° 12'	49,169	53,297	64,769	.260	1.961
0.50	60° 0'	44° 10'	38° 24'	48,205	52,252	63,499	.250	2.000
0.48	57° 22'	42° 18'	36° 49'	46,277	50,162	60,959	.230	2.083
0.46	54° 47'	40° 28'	35° 15'	44,349	48,072	58,419	.212	2.174
0.45	53° 30'	39° 33'	34° 27'	43,385	47,026	57,149	.203	2.222
0.44	52° 13'	38° 38'	33° 40'	42,420	45,981	55,879	.194	2.273
0.42	49° 40'	36° 49'	32° 5'	40,492	43,891	53,339	.176	2.381
0.40	47° 9'	35° 0'	30° 31'	38,564	41,801	50,799	.160	2.500
0.38	44° 40'	33° 12'	28° 57'	36,636	39,711	48,259	.144	2.632
0.36	42° 12'	31° 24'	27° 24'	34,708	37,621	45,719	.130	2.778
0.35	40° 58'	30° 30'	26° 38'	33,744	36,576	44,449	.123	2.857
0.34	39° 44'	29° 37'	25° 51'	32,779	35,531	43,179	.116	2.911
0.32	37° 20'	27° 51'	24° 18'	30,851	33,441	40,639	.102	3.125
0.30	34° 56'	26° 4'	22° 46'	28,923	31,351	38,099	.090	3.333
0.28	32° 32'	24° 18'	21° 14'	26,995	29,261	35,559	.078	3.571
0.26	30° 10'	22° 33'	19° 42'	25,067	27,171	33,019	.068	3.846
0.25	28° 58'	21° 40'	18° 56'	24,103	26,126	31,749	.063	4.000
0.24	27° 46'	20° 48'	18° 10'	23,138	25,081	30,479	.058	4.167
0.22	25° 26'	19° 2'	16° 38'	21,210	22,991	27,940	.048	4.545
0.20	23° 4'	17° 18'	15° 7'	19,282	20,901	25,400	.040	5.000
0.18	20° 44'	15° 34'	13° 36'	17,354	18,811	22,860	.032	5.555
0.16	18° 24'	13° 50'	12° 5'	15,426	16,721	20,320	.026	6.250
0.15	17° 14'	12° 58'	11° 19'	14,462	15,676	19,050	.023	6.667
0.14	16° 5'	12° 6'	10° 34'	13,498	14,630	17,780	.020	7.143
0.12	13° 47'	10° 22'	9° 4'	11,570	12,540	15,240	.014	8.333
0.10	11° 29'	8° 38'	7° 34'	9,641	10,450	12,700	.010	10.000
0.08	9° 11'	6° 54'	6° 3'	7,713	8,360	10,160	.006	12.500
0.06	6° 53'	5° 10'	4° 32'	5,785	6,270	7,620	.004	16.667
0.05	5° 44'	4° 18'	3° 46'	4,821	5,225	6,350	.003	20.000

**GREATLY REDUCED PRICES**  
OF  
**OBJECT-GLASSES MANUFACTURED BY**  
**R. & J. BECK,**  
68, CORNHILL, LONDON, E.C.

**PRICES OF BEST ACHROMATIC OBJECT-GLASSES.**

No.	Focal length.	Angle of aperture, about	Price.	Linear magnifying-power, with 10-inch body-tube and eye-pieces.				
				No. 1.	No. 2.	No. 3.	No. 4.	No. 5.
100	4 inches .. ..	0	£ s. d. 1 10 0	10	16	30	40	50
101	3 inches .. ..	7	1 10 0	15	24	45	60	75
102	3 inches .. ..	12	2 10 0					
103	2 inches .. ..	10	1 10 0	22	36	67	90	112
104	2 inches .. ..	17	2 10 0					
105	1½ inch .. ..	23	2 10 0	30	48	90	120	150
106	1 inch .. ..	25	2 0 0					
107	1 inch .. ..	32	2 10 0	70	112	210	280	350
108	¾ inch .. ..	45	2 10 0					
109	⅔ inch .. ..	65	4 0 0	100	160	300	400	500
110	⅕ inch .. ..	95	5 0 0	125	200	375	500	625
111	⅙ inch .. ..	75	3 10 0	150	240	450	600	750
112	⅙ inch .. ..	120	4 10 0	200	320	600	800	1000
113	⅙ inch .. ..	130	5 0 0	400	640	1200	1600	2000
114	⅙ inmm. .. ..	180	5 5 0	250	400	750	1000	1250
115	⅙ inmm. .. ..	180	8 0 0	400	640	1200	1600	2000
116	⅙ inmm. .. ..	180	10 0 0	500	800	1500	2000	2500
117	⅙ inch .. ..	160	20 0 0	750	1200	2250	3000	3750
				1000	1600	3000	4000	5000
				2000	3200	6000	8000	10,000

**ECONOMIC ACHROMATIC OBJECT-GLASSES,**

APPLICABLE TO ALL INSTRUMENTS MADE WITH THE UNIVERSAL SCREW.

No.	Focal length.	Angle of aperture, about	Price.	MAGNIFYING-POWER, with 6-inch body and eye-pieces.		
				No. 1.	No. 2.	No. 3.
150	3 inches .. ..	0	£ s. d. 1 0 0	12	15	27
151	2 inches .. ..	8	1 0 0	18	23	41
152	1 inch .. ..	18	1 5 0	46	61	106
153	¾ inch .. ..	38	1 5 0	90	116	205
154	½ inch .. ..	80	1 5 0	170	220	415
155	⅓ inch .. ..	110	2 5 0	250	330	630
156	⅓ inch .. ..	110	3 10 0	350	450	800
157	⅙ inmm. .. ..	180	6 0 0	654	844	1500

Revised Catalogue sent on application to

**R. & J. BECK, 68, Cornhill.**



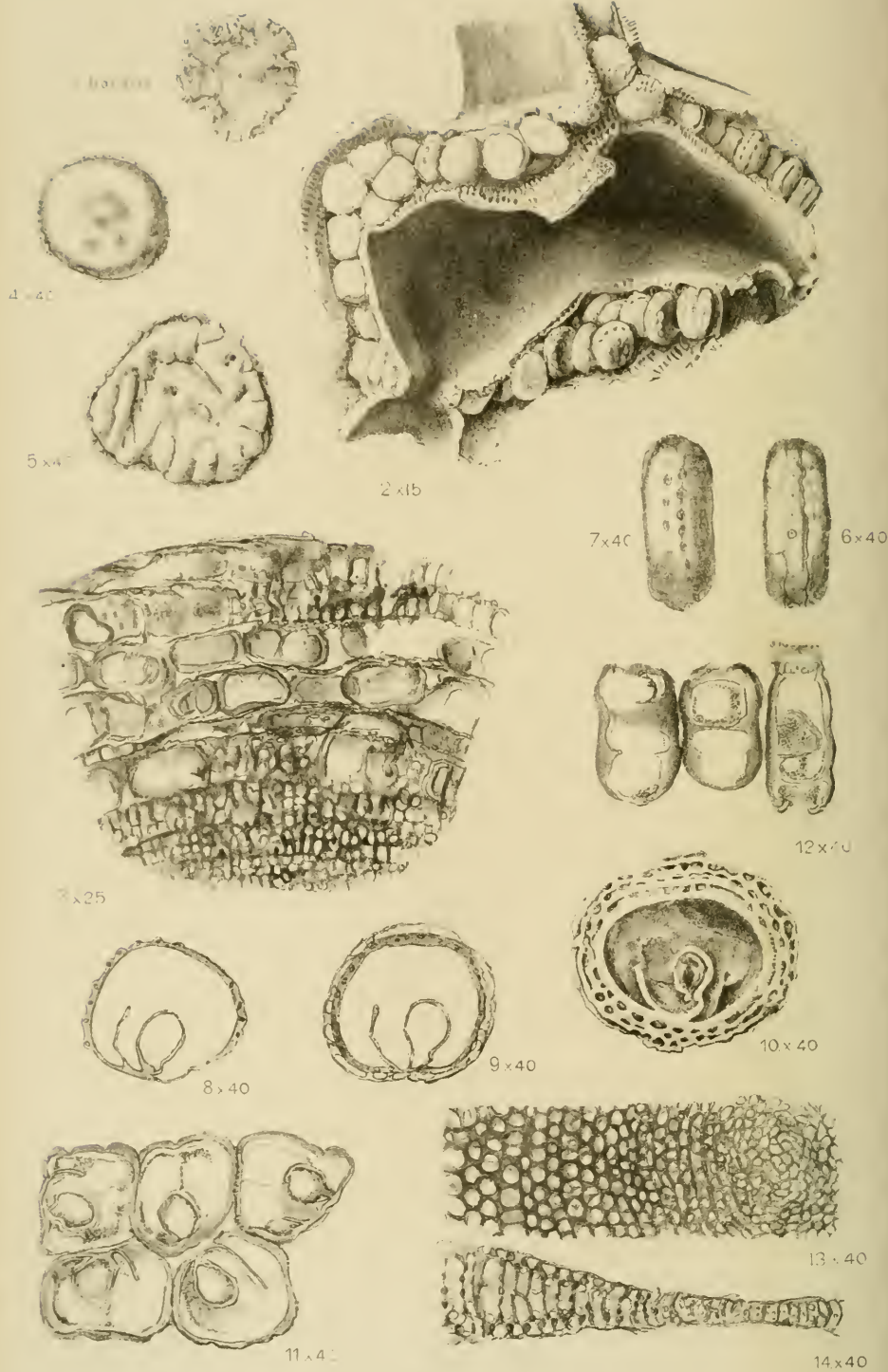

ORBITOLITES COMPLANATA Var. LACINIATA.

# JOURNAL

OF THE

## ROYAL MICROSCOPICAL SOCIETY.

OCTOBER 1888.

### TRANSACTIONS OF THE SOCIETY.

IX.—*Note on the Reproductive Condition of Orbitolites complanata, var. laciniata.*

By HENRY B. BRADY, F.R.S.

(Read 10th October, 1888.)

#### PLATE X.

AMONGST the Foraminifera that have their home in the shallow waters of the coral-islands of the South Pacific, one of the most remarkable is the large Orbitolite with “crumpled” edges, known as *Orbitolites complanata*, var. *laciniata*. It can scarcely be called a common form, inasmuch as its occurrence, so far as at present known, is confined to the Friendly Islands and the Fiji group, though in certain favourable localities it is tolerably abundant. I have never observed it in New Caledonia, where the more typical forms exist in the greatest profusion and specimens of *Orbitolites complanata* in the normal condition often attain dimensions nearly as great; nor, so far as I recollect, on the reefs of Samoa. A considerable gathering of the variety referred to was made on the ‘Challenger’ expedition, and some of these specimens

#### EXPLANATION OF PLATE X.

- Fig. 1.—*Orbitolites complanata*, var. *laciniata*, from the Suva reef; natural size.
- „ 2.—Peripheral view of a portion of the margin, the perforated external wall broken away, showing the outer annulus crowded with young embryonic shells, corresponding to the “primitive discs” of adult normal specimens .. × 15 diam.
- „ 3.—Transparent horizontal section of the marginal annuli of a portion of the shell with embryos *in situ* .. .. × 25 „
- „ 4, 5.—Embryos (“primitive discs”); lateral aspect .. .. × 40 „
- „ 6, 7.—————, one showing a single row of apertures, the other two rows;—peripheral aspect .. × 40 „
- „ 8, 9.—————, horizontal sections, seen by transmitted light .. .. × 40 „
- „ 10.—Young specimen, with three annuli of chamberlets, laid open to show the interior .. .. × 40 „
- „ 11, 12.—Masses of embryos—horizontal and transverse sections—by transmitted light .. .. × 40 „
- „ 13.—Horizontal section of the central portion of an adult specimen, by transmitted light .. .. × 40 „
- „ 14.—Transverse section of a similar shell .. .. × 40 „

were described in more or less detail by the late Dr. Carpenter \* and myself. †

On my visit to Fiji at the end of the year 1884, my attention was naturally turned to this amongst other Foraminifera peculiar to the region, but beyond a few worn examples, apparently dead shells, found on the beach at Loma-Loma, my search for it was at first almost fruitless. The weather was stormy, I had been delayed by vexatious quarantine regulations until the hurricane season had set in, and I could rarely get out to the reefs. When at last I was able to land on the reef off Suva, I soon met with the object of my quest, though the specimens, as we shall presently see, did not correspond in all respects with those collected in such numbers by the 'Challenger' naturalists. To my surprise the shells were parasitic, generally firmly attached to a green Alga which flourishes amongst the coral-sand at the bottom of the shallower pools on the reef;—I had previously supposed that the adherent habit of the Orbitolite ceased at a very early stage in the growth of the disc. Their peripheral edges were exceedingly brittle—so fragile indeed that it was often impossible to remove the specimens without more or less breakage. Other slight peculiarities were apparent, but there was little opportunity for close examination on the spot.

In working over the material collected in Fiji, since my return, my attention was attracted to these specimens, not only by the peculiarity of their general appearance, but more particularly by what seemed to the naked eye to be a number of very young individuals adhering to the central portion of one of the flatter discs; and on further investigation I found that not only was this inference correct, but that the marginal annuli, wherever the interior was exposed by fracture, were crowded with similar minute embryonic shells; and further, that the coral-sand obtained from the same pools contained enormous numbers of young specimens in various stages of development, together with fragments of the thin, perforated, annular septa of the parent shells.

The occurrence of young individuals in this position is not altogether a new fact. Many years ago Prof. W. K. Parker found "a number of very young specimens, consisting simply of the primordial chamber and the one surrounding it" in the "deeply channelled margin of one of these plicated forms of *Orbitolites*"; ‡ and the same specimens are referred to in Dr. Carpenter's 'Challenger' Report, as "consisting only of the 'nucleus' and a single annulus of sub-segments," the author adding that he had found "similar specimens in the same situation in some of the large Fijian discs." § My own examination of a considerable number of the 'Challenger' specimens leads me to think that the occurrence amongst them of such examples must be comparatively rare; and not one of the

\* 'Report on the Genus Orbitolites,' p. 35, pl. vii.

† 'Report on the Challenger Foraminifera,' p. 220, pl. xvi., figs. 8-11.

‡ Carpenter, 'Introduction to the Study of the Foraminifera,' p. 33, pl. iv., fig. 22.

§ 'Report on the Genus Orbitolites,' p. 16.

numerous sections I have made from them reveals a single such embryo *in situ*. Be this as it may, it is quite safe to say that specimens in the precise condition of those now brought under notice are practically new to morphologists.

The specimens obtained on the Suva reef vary a good deal as to size and external characters; the drawing, Plate X. fig. 1, represents one of the larger and more characteristic of them. The dimensions range from a diameter of about a quarter of an inch to very nearly an inch (6 mm. to 24 or 25 mm.); but from the broken edges of the smaller discs it may be inferred that they have lost some of their outer annuli. At the centre, the disc is often not more than  $1/300$  of an inch (0.08 mm.) in thickness, but this increases rapidly, though by no means regularly, towards the circumference. The shells are seldom so massively built as those in the 'Challenger' collection or as others which have come under my notice. The 'Challenger' specimens, if I understand rightly, were found unattached, in some of the more sheltered pools on the reefs, and as they were taken at a different season of the year (in July) they may perhaps represent a later stage in the history of the animal.

The plication of the margin is also a very variable feature; for whilst some of the discs are very deeply lobed and divided, others, generally those of smaller size, are only slightly crenulated, and the peripheral edge shows little tendency to duplication. The edges are often ragged and grooved, owing to the breaking away of the external annular septum, whilst the lateral walls are left standing. Wherever the peripheral wall is fractured, the annular space it inclosed is seen to be completely filled with young shells in the earliest stages of development, as shown in fig. 2. These, however, are not confined to the outermost circlet. If a horizontal section of the disc be made no less than five or six of the outer annuli may often be found more or less closely packed with these little bodies (fig. 3). It was previously known that the later chambers of this variety of *Orbitolites* were not regularly subdivided into chamberlets on the normal plan,\* but the explanation which could only be conjectured is now obvious.

The embryo shells correspond exactly with what is termed by Carpenter the "primitive disc" or "nucleus" of the typical *Orbitolites complanata*. They are compressed discs generally rounded, often nearly circular, in outline, but sometimes slightly irregular, or even subangular (figs. 4-7). Their diameter ranges from  $1/60$  to  $1/30$  in. (0.4 mm. to 0.8 mm.), their thickness averaging about  $1/100$  in. (0.25 mm.). The lateral surfaces are flat or somewhat convex, seldom perfectly even, but more frequently marked by slight irregular elevations and depressions (figs. 4, 5). The peripheral edge is rounded and presents either one or two rows of perforations placed at tolerably regular intervals on a slightly elevated ridge (figs. 6, 7). The orifices are sometimes situated in small nipple-like protuberances. The

\* This is well shown in the drawing of a transverse section in the 'Report on the Challenger Foraminifera,' pl. xvi., fig. 11.

interior invariably presents the same general characters—a primordial chamber of relatively small dimensions, and a curved shelly process springing from its base—apparently the incomplete septum of a second segment; the whole inclosed in a large “circumambient chamber” (figs. 8, 11). I have not in any case observed the commencement of the annular mode of growth characteristic of the mature shell, until after the embryo has left the parent. Subsequently the peripheral apertures form the connection with the first annulus of chamberlets (fig. 9); and from this point it is easy to follow the successive stages of the growth of the test. Fig. 10 is drawn from a young specimen consisting of the embryo or “primitive disc” and three annuli of chamberlets, the test laid open so as to show the interior.

One interesting point remains. There is no difficulty, as has just been remarked, in tracing the growth of the shell, by the addition of successive annuli of gradually increasing thickness, until the full size of the adult *Orbitolites complanata* is reached. The relatively large “primitive disc” remains a conspicuous feature throughout, as shown in almost every published drawing illustrating the structure of the complex type of the genus. But the adult specimens under notice—that is to say, the parent shells—present no such feature. The drawings, figs. 13, 14, represent horizontal and transverse sections of the central portions of two of these large viviparous specimens, the magnifying power employed being the same as in figs. 4–12. By the horizontal section it will be seen that, in place of the “primitive disc,” the centre is occupied by a multitude of small chamberlets arranged on no very regular plan; and what is more remarkable is the fact revealed by the transverse section, namely, that at its centre the adult test is scarcely  $\frac{1}{300}$  in. (0.08 mm.) in thickness, or only about one-third of the thickness of an embryo of average size. The ‘Challenger’ specimens of the same form, such as I have examined, though more stoutly built, show the same absence of a “primitive disc.” In one or two instances I have observed at the centre of the shell a small convexity, not unlike the structure referred to in point of size and outline; but further examination showed that in every case it consisted of a labyrinthine mass of little chamberlets, to all appearance of exogenous growth.

We are indebted mainly to the labours of two French naturalists, MM. Munier-Chalmas and Schlumberger, for a knowledge of the existence of a sort of “dimorphism” amongst the Foraminifera. They have shown that in certain families, perhaps in all, but notably in the Miliolidæ, each species presents itself in two forms; one of which, called by them “Form A,” has a large primordial chamber and consists altogether of but few segments; whilst the other, “Form B,” has a small initial chamber, and the succeeding segments are relatively numerous. Two possible explanations are indicated by the authors, the one which they prefer is based upon the supposition that “each individual passes through two successive phases, the first of which would

correspond to Form A, but that after a process of resorption of the large central chamber, the animal constructs a series of new chambers corresponding to Form B.”\* The authors further state, as an objection to the alternative theory of the distinct origin of the two forms, that they “have not been able to discover amongst the numerous species they have studied any very young individuals of Form B.” The case before us, in which the young individuals taken from the parent shell exhibit the large initial chambers, whilst in the parent itself the centre is occupied by numerous chambers of relatively minute size, gives great weight to the former explanation.

The question naturally arises, whether the embryonic forms which have been described are the result of sexual intercourse of any kind, or simply of a process of gemmation. With reference to the “dimorphism” of the Foraminifera, Mr. Geddes has suggested that “the better grown and less modified” shell “with fewer partitions and a ‘*grand loge central*’ seems distinctly the anabolic or female, the other, since smaller and more modified, the male;”† but as yet this view is founded on analogy rather than direct observation. The probabilities in the present case are in favour of simple gemmation, and, if this be correct, the mere fact of the presence of very young shells in the manner described has no bearing either way on the question of sex. On the other hand, it must be admitted that the change of the individual from one form to the other, if clearly established, would render the sexual theory superfluous.

It is possible that the same explanation may serve both for the plicate margin of the discs and the production of large broods of young individuals, and that both may be due to redundant growth consequent upon exceptionally favourable external conditions and a plentiful supply of food.

It is to be regretted that none of the specimens were preserved in alcohol. Verworn has recently shown that the presence of a nucleus is essential to even simple, scarcely more than vegetative, processes amongst the Foraminifera,‡ and it would have been interesting to trace the relation, which may be assumed to exist, between the numerous minute nuclei, found by Bütschli in the plasma of the peripheral chambers of the Orbitolite§ and the young individuals which make their appearance in such abundance in the same portion of the test.

\* Comptes Rendus, xcvi. (1883) p. 1601.

† Proc. Roy. Soc. Edinb., xiii. (1886) p. 931. The idea originated with de la Harpe, but does not appear to have been seriously entertained by him.

‡ Zeitschr. für Wiss. Zool., xlvi. (1888) pp. 455-470, pl. xxxii.

§ Morph. Jahrb., xi. (1885) p. 80, &c., pl. vii. figs. 1, 4.

X.—Notices of New Infusoria Flagellata from American Fresh Waters.

By ALFRED C. STOKES, M.D.

(Read 9th May, 1888.)

PLATE XI.

*Mastigamæba flexuosa*, sp. nov. Fig. 1.

EXTENDED body elongate-ovate or sublinear, from five to six times as long as broad; the anterior extremity obtusely pointed; pseudopodia numerous, their length equalling or exceeding the breadth of the body, smooth, tapering, seldom branching, those of the posterior extremity similar to the lateral ones, or fine, filamentous and short, or both; the posterior border also often emitting a broad, irregular, wave-like pseudopodium; anterior extremity usually exhibiting a lateral, anteriorly directed pseudopodium on each side of the flagelliferous apex; endoplasm of the pseudopodia containing many short, fine, colourless, rod-like structures; endoplasm of the body coarsely granular, frequently inclosing numerous greenish-yellow food-masses, the granules entering the pseudopodic extensions for only a short distance; flagellum about one-half the length of the body; contractile vesicle apparently single, near the posterior extremity; nucleus (?) subpyriform, close to the anterior extremity. Length of body  $1/150$  in. Habitat: Pond water.

The movements are slow so far as progression is concerned, but quite active in connection with change of form, the soft body bending on itself, shortening, lengthening, and undergoing various other changes of shape with considerable rapidity. Excrementitious particles are extruded with some force, apparently from any portion of the surface.

*Cercomonas truncata*, sp. nov. Figs. 2-6.

Body ovate or elongate flask-shaped, soft, flexible and changeable in form, especially posteriorly; length from two to four times the breadth; dorsal surface rounded, the ventral flattened, sometimes slightly concave; posterior extremity usually rounded, the anterior narrow and truncate; posterior appendage trailing, stout, exceeding the body in length, largest near the body, tapering and changeable in

EXPLANATION OF PLATE XI.

Fig. 1.—*Mastigamæba flexuosa*.  
 ,, 2-6.—*Cercomonas truncata*.  
 ,, 7.— „ *heterofilum*.  
 ,, 8.— „ *lapsa*.  
 ,, 9.— „ *undulans*.  
 ,, 10-12. „ *mutabilis*.  
 ,, 13.—*Heteromita granulifera*.  
 ,, 14, 15. „ *tremula*.  
 ,, 16.— „ *stagnatilis*.  
 ,, 17.— „ *Sphagni*.

Fig. 18.—*Heteromita nasuta*.  
 ,, 19.— „ *parvifilum*.  
 ,, 20.—*Tetramitus frondarius*.  
 ,, 21.—*Hexamita truncata*.  
 ,, 22.—*Atractonema pusilla*.  
 ,, 23.—*Hymenomonas flava*.  
 ,, 24.—*Hymenomonas fusiformis*.  
 ,, 25.—*Zygoselmis obovata*.  
 ,, 26.—*Sterromonas parvula*.  
 ,, 27.—*Anisonema obliqua*.

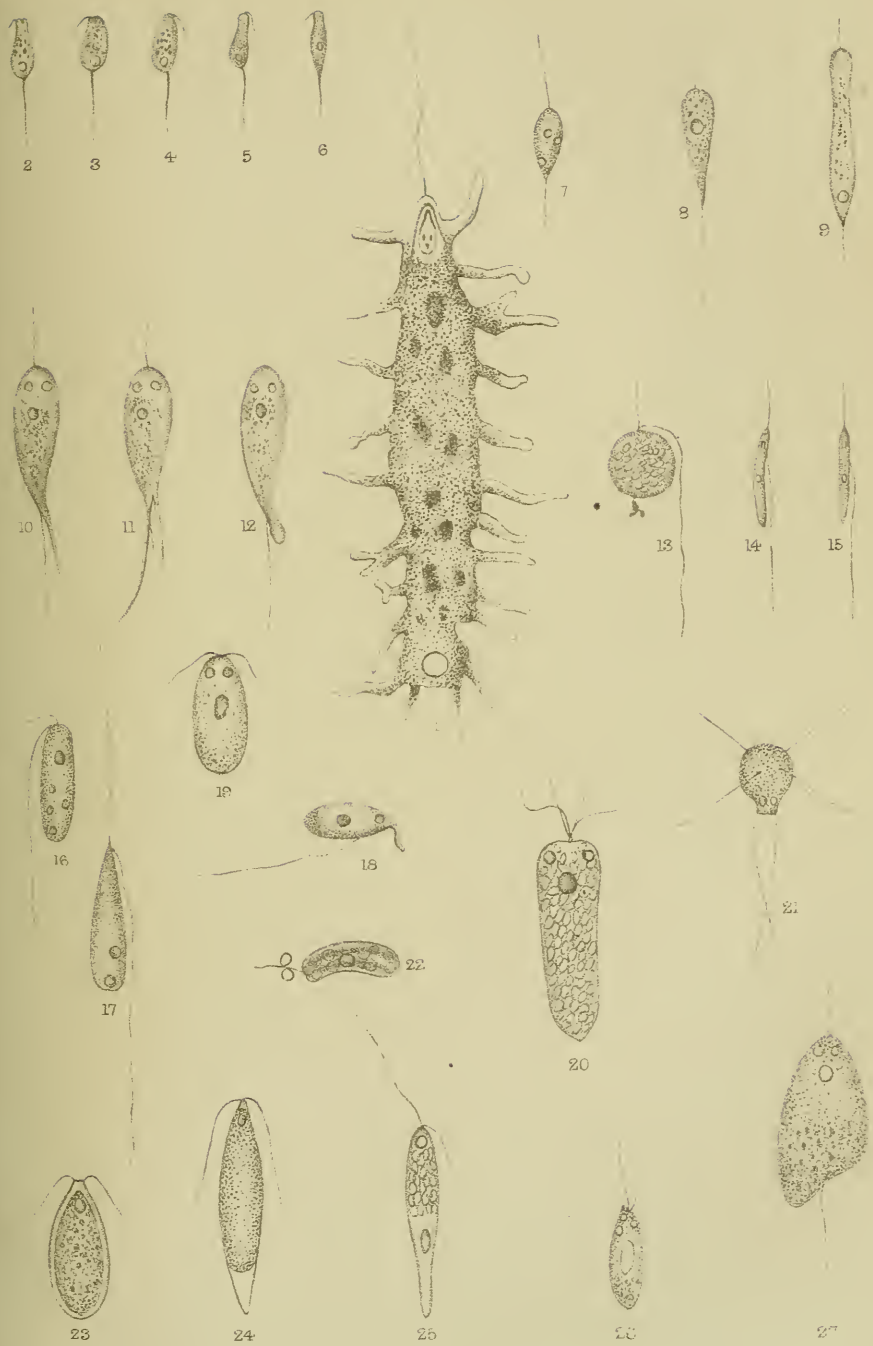

A. S. del. et nat.

West, Newman & Co. lith.

New American Infusoria Flagellata



thickness and contour, the anterior flagellum short, fine, originating from the left-hand angle of the truncate frontal margin, its length not exceeding one-half that of the body, its movements not rapid; contractile vesicle single, located near the posterior extremity; endoplasm often inclosing numerous granules. Length of body from  $1/4500$  to  $1/2250$  in. Habitat: Standing pond water with *Sphagnum*. Movements slowly gliding.

*Cercomonas heterofilum*, sp. nov. Fig. 7.

Body ovate, obovate, or suboval, soft and changeable in shape, about twice as long as broad; anterior border rounded; posterior margin tapering and obtusely pointed; anterior vibratile flagellum about one and one-half times as long as the body, the trailing caudal prolongation subequal to the zooid in length; nucleus apparently subcentral; contractile vesicles two, one near the posterior extremity close to the left-hand body margin, the other near the centre of the right-hand side; endoplasm finely granular. Length of body  $1/2250$  in. Habitat: Standing pond water with aquatic plants.

*Cercomonas lapsa*, sp. nov. Fig. 8.

Body obovate, about three times as long as broad, rounded and widest anteriorly, tapering to the posterior extremity, where it is continued as a flexible tail-like prolongation equalling or exceeding the body in length, and not rarely extending and retracting a fine, flexible filament; anterior flagellum not equalling the body in length; contractile vesicle apparently single, subcentrally located; endoplasm finely granular and occasionally inclosing several small, dark-bordered particles which change their position with the motion of the sarcodite; zooid's movements slow and smoothly gliding. Length of body,  $1/2250$  in. Habitat: Pond water with decaying *Sphagnum*.

*Cercomonas undulans*, sp. nov. Fig. 9.

Body elongate obovate, from five to six times as long as broad, much depressed, very soft, flexible and changeable in shape; posterior border tapering and terminating in a fine, flexible, tail-like trailing appendage about one-third as long as the zooid; anterior border rounded; vibratile flagellum slender, about one-third as long as the zooid; anterior extremity expanded, flattened, constricted behind the rounded frontal border; contractile vesicle single, near the posterior extremity, close to one lateral border. Length of body  $1/1800$  in. Habitat: An infusion of decaying *Sphagnum*. Movements by lateral flexure and undulations of the soft body.

*Cercomonas mutabilis*, sp. nov. Figs. 10, 11, 12.

Body obovate, soft, flexible and changeable in shape, twice as long as broad, the anterior border rounded; the posterior extremity pointed, soft and plastic, emitting one or more short, lobate, sarcodic extensions, or one or more long, irregularly linear pseudopodic prolongations which

are quickly withdrawn; anterior flagellum scarcely equalling the body in length, apparently arising from the lower surface a short distance behind the frontal margin; caudal flagelliform appendage trailing, not equalling the body in length, constant and unchangeable in shape; contractile vesicle double, spherical, close to the frontal border; nucleus spherical, subcentrally situated; endoplasm granular, often inclosing numerous yellowish food-particles; excrementitious matters extruded near the posterior extremity, apparently from the right-hand side only. Length of body  $1/1500$  in. Habitat: Standing pond water.

*Heteromita granulifera*, sp. nov. Fig. 13.

Body subspherical, smooth, slightly changeable in shape; endoplasm often densely crowded with comparatively coarse, dark-bordered granules; nucleus and contractile vesicle obscured by the endoplasmic granules; flagella slender, originating close together at the centre of the frontal border, the anterior subequal to the body in length, the trailing appendage from four to five times as long as the zooid; anal aperture near the posterior extremity. Length of body  $1/3000$  in. Habitat: An infusion of decaying *Sphagnum* with pond-water.

This differs from *H. globosa* (Stein) S. K., in its somewhat smaller size, its smooth surface, and especially in the comparative length of the flagella, and their point of origin, these appendages in *H. globosa* being subequal in length, and arising from a point on the anterior portion of the ventral surface.

*Heteromita tremula*, sp. nov. Figs. 14, 15.

Body elongate, subcylindrical or subfusiform, from four to five times as long as broad, not conspicuously changeable in shape, usually slightly curved toward the ventral surface; both extremities obtusely pointed, the anterior somewhat the narrower; flagella unequal in length and size, the anterior stout, about one-half as long as the body, the posterior, or trailing, appendage slender, arising at some distance from the anterior border, twice as long as the body; nucleus apparently subcentral; contractile vesicle near the anterior extremity. Length of body  $1/4500$  to  $1/3000$  in. Habitat: Standing pond water. Movements by rapid lateral undulations, with a sudden reversal of the direction of the zooid's forward progression.

*Heteromita stagnatilis*, sp. nov. Fig. 16.

Body cylindrical, three times as long as broad, not noticeably changeable in shape. the surface smooth; posterior margin rounded; anterior border convexly truncate; flagella diverse in length, originating close together at the frontal margin, the anterior or vibratile appendage less than one-half as long as the body, the trailing about twice the body in length; contractile vesicles several, scattered; nucleus subcentrally located. Length of body  $1/2250$  in. Habitat: Standing pond water, with *Lemna* and other aquatic plants.

*Heteromita Sphagni*, sp. nov. Fig. 17.

Body elongate ovate, smooth, about four times as long as broad, somewhat depressed; anterior border acutely pointed, the posterior rounded, the posterior region flattened; one lateral border convex, the opposite flattened, nearly straight; flagella subequal in size and length, each about twice as long as the body, inserted at the anterior apex of the zooid; contractile vesicle single, conspicuous, situated in the posterior body-half, near the flattened lateral border; nucleus represented by a circular light spot near the posterior extremity, in the median line. Length of body  $1/750$  in. Habitat: Standing pond water, with *Sphagnum*.

*Heteromita nasuta*, sp. nov. Fig. 18.

Body ovate, smooth, somewhat depressed, very slightly changeable in form, about twice as long as broad, the posterior extremity rounded, the anterior produced into a stout, undulating flagellum less than one-half as long as the zooid; posterior or trailing flagellum slender, about twice as long as the body, arising from the ventral surface at some distance from the frontal border; contractile vesicle apparently single, situated near the anterior extremity; nucleus presumably subcentrally located. Length of body  $1/4500$  in. Habitat: Standing pond water, with decaying *Sphagnum*.

This form is readily recognizable by the peculiar and characteristic condition of the anterior flagellum. This appendage is thick, stout, and apparently a continuation of the apical extremity of the body. It presents much the appearance of a comparatively robust, vibratile, proboscidiform prolongation. In a few instances it has been observed to become thickened by a temporary outflow of sarcode from the body.

*Heteromita parvifilum*, sp. nov. Fig. 19.

Body ovate, smooth, slightly changeable in form, less than twice as long as broad, the posterior extremity rounded, the anterior obtusely pointed; flagella subequal, less than one-half as long as the body; contractile vesicles two, situated side by side, at the anterior extremity; nucleus broadly ovate or subspherical, subcentrally located; endoplasm granular, especially at the posterior extremity. Length of the body  $1/3000$  to  $1/2250$  in. Habitat: A vegetable infusion.

*Tetramitus frondarius*, sp. nov. Fig. 20.

Body very soft and changeable in form, normally elongate, sub-cylindrical, about three times as long as broad, the posterior border obtusely pointed, the anterior truncate and often centrally emarginate; flagella in length somewhat exceeding the width of the body, originating close together near the centre of the frontal margin; nucleus apparently subspherical, situated in the anterior body-half;

contractile vesicles two, small, one placed on each side near the anterior extremity; endoplasm inclosing numerous dark-bordered corpuscles. Length of body  $1/640$  in. Habitat: An infusion of dead leaves.

*Hexamita truncata*, sp. nov. Fig. 21.

Body broadly obovate, soft and changeable in shape, less than twice as long as broad; frontal border rounded, the posterior extremity usually constricted and prolonged as a short, somewhat flattened extension with subparallel lateral borders, and a truncate posterior margin; anterior flagella four, arising from the body at some distance from the anterior border, each extended rigidly at right angles with the surface, the distal extremities more or less curved; posterior trailing flagella two, less than three times as long as the body, each arising from a lateral border of the posterior truncate prolongation; contractile vesicles two, placed near the origin of the posterior body extension; endoplasm granular; movements rotatory on the longitudinal axis. Length of body  $1/2250$  in. Habitat: Standing water, with *Sphagnum*.

*Petalomonas orbicularis*, sp. nov.

Body suborbicular or broadly ovate, the length but slightly exceeding the breadth, much depressed, the lateral borders curved toward the ventral aspect, so that the dorsal surface is evenly convex, the ventral concave; lateral and anterior borders rounded, the anterior slightly emarginate centrally, the posterior extremity rounded or slightly tapering and obtusely pointed; flagellum subequal to the body in length; oral aperture distinct, apparently followed by a short pharyngeal passage; nucleus spherical, subcentrally located; contractile vesicle single, placed in the median line in close proximity to the pharyngeal passage; endoplasm often inclosing numerous dark-bordered, probably amyloceous corpuscles, which slowly change their position. Length of body  $1/1500$  in.; greatest width  $1/1285$  in. Habitat: Standing pond water, with *Sphagnum*. Movements rotatory on the longitudinal axis.

*Atractonema pusilla*, sp. nov. Fig. 22.

Body subcylindrical, from 3-5 times as long as broad, curved toward the lower or ventral surface, the dorsal aspect evenly convex, the opposite or ventral border concave, the surfaces longitudinally traversed by from 6-8 straight or slightly oblique furrows; frontal margin slightly emarginate, the posterior border rounded; flagellum subequal to the body in length; endoplasm colourless, often inclosing near the extremities of the body several dark-bordered, probably amyloceous corpuscles; contractile vesicle single, near the centre of one lateral border; pharyngeal passage small but distinct. Length of the body  $1/1000$ - $1/1200$  in. Movements rotatory on the longitudinal axis. Habitat: Standing water with decaying *Sphagnum*. Reproduction by longitudinal fission.

*Hymenonema* (*ὑμην*, membrane; *νημα*, thread), gen. nov.

Animalcules free-swimming, inhabiting a flexible, membranous lorica, and inclosing two laterally developed pigment-bands; flagellum single; no eye-spot. Habitat: Fresh water.

The presence of but one flagellum is the only distinguishing feature between the animalcules of this generic group and the *Hymenomonas* of Stein. The lorica apparently possesses the same peculiarity of flexibility and the power to somewhat change its contour as are possessed by *Hymenomonas*.

*Hymenonema Sphagni*, sp. nov.

Lorica ovate, flexible and slowly changeable in form, often less than twice as long as broad, the entire surface covered with rounded, shallow depressions; inclosed zooid entirely filling the cavity of the lorica; colour-bands yellowish-brown, broad, almost meeting in the centre of the body; flagellum single, shorter than the lorica, its distal end usually arcuately curved; contractile vesicle single or double, situated at the anterior extremity; a refractive corpuscle usually conspicuously developed in the anterior body-half, near the centre of one lateral border. Length of lorica 1/750 in. Habitat: Pond water with *Sphagnum*.

*Hymenomonas flava*, sp. nov. Fig. 23.

Lorica ovate, punctate, twice as long as broad, very slightly flexible, the posterior extremity rounded, the anterior prolonged into a short, inconspicuous, neck-like extension, the frontal margin truncate; body filling the entire lorica except the neck-like prolongation; endoplasm yellow, inclosing numerous granules; contractile vesicle apparently single, antero-terminal; flagella not equalling the lorica in length, usually only one-fourth as long. Length of lorica 1/1125 in. Habitat: Standing pond water, with decaying *Sphagnum*.

*Hymenomonas fusiformis*, sp. nov. Fig. 24.

Lorica subfusiform, less than four times as long as broad, widest centrally, the anterior border pointed, the posterior extremity obtusely and narrowly rounded; the body usually filling the entire lorica, but often somewhat removed from both extremities of the sheath; endoplasm yellow; contractile vesicle double, small, near the anterior extremity; nucleus obscure, apparently subcentrally located; flagella about one-half as long as the lorica. Length 1/690 in. Habitat: Standing pond water, with *Sphagnum*. Movements rotatory on the longitudinal axis.

*Zygoselmis obovata*, sp. nov. Fig. 25.

Body normally elongate obovate, about seven times as long as broad; anterior extremity obtusely pointed, the posterior rounded; flagella diverse, the longer subequal to the extended body in length,

shorter from one-third to one-fourth as long; contractile vesicle near the frontal border; nucleus ovate, subcentrally placed; endoplasm inclosing numerous dark-bordered corpuscles, usually aggregated at the anterior extremity, thus leaving the posterior region clear and transparent. Length of body  $1/428$  in. Habitat: A standing vegetable infusion in fresh water.

*Sterromonas parvula*, sp. nov. Fig. 26.

Body elongate ovate, somewhat gibbous, about twice as long as broad, the posterior extremity rounded, the anterior obliquely truncate, slightly excavate; flagella rising from near the centre of the frontal margin, close together, the longer about one-half as long as the body, held stiffly in advance, the distal extremity arcuately curved; the shorter flagellum extremely small, about one-third, or less, as long as the primary appendage; contractile vesicles two or three, near the anterior extremity, two near the frontal border (one on each side), a third often developed near one lateral margin; nucleus (?) large, ovate, subcentral; endoplasm granular posteriorly. Length of body  $1/2250$  in. Habitat: A vegetable infusion.

*Anisonema obliqua*, sp. nov. Fig. 27.

Body ovate, about twice as long as broad, the anterior extremity narrowed, obtusely pointed, the posterior obliquely truncate and emarginate; dorsal surface smooth, convex, the ventral concave; flagella diverse in length, arising near together at the anterior extremity, the vibratile short, the trailing rather less than twice as long as the zooid; contractile vesicles two, one on each side of the median line near the anterior extremity; nucleus subcentral; pharyngeal passage obscure; endoplasm usually granular posteriorly. Length of body  $1/1500$  in. Habitat: Standing pond water.

---

SUMMARY  
OF CURRENT RESEARCHES RELATING TO  
ZOOLOGY AND BOTANY  
(*principally Invertebrata and Cryptogamia*),  
MICROSCOPY, &c.,

INCLUDING ORIGINAL COMMUNICATIONS FROM FELLOWS AND OTHERS.\*

ZOOLOGY.

A. VERTEBRATA:—Embryology, Histology, and General.

a. Embryology.†

Formation of Polar Globules in Animal Ova.‡—Prof. A. Weismann and Mr. C. Ischikawa have investigated the history of the polar globules in various parthenogenetic ova. It will be remembered that, in 1885, the former of these writers discovered that a polar globule was formed in the parthenogenetic egg of *Polyphemus oculus*; the conversion of the germinal vesicle into the globule, the cellular nature of the latter, and its later division into two cells were observed, as well as the fate of the portion of the nucleus which remained in the egg, and which became the cleavage-nucleus. An account is now given of the fourteen cases recently observed, chiefly by the authors of this paper, in which it is certain that parthenogenetic ova give rise to one polar globule only; among these are *Leptodora hyalina*, *Sida crystallina*, *Cypris reptans*, *Conochilus volvox*, and an *Aphis* (Blochmann).

A list is given of a number of cases in which two primary globules have been observed, and this extends from Cœlenterates to Mammals; it would have been much longer had it not been confined to a record of the cases in which the describer distinctly states that the globules have been successively given off from the nucleus of the egg. In a few cases where sexual reproduction occurs, it has been stated that only one globule has been observed; but there is only one case, that of *Gonothyrea Loveni*, in which the observer (in that case Bergh) remarks definitely that there is never more than one globule. It is to be noted, however, that Bergh himself states that the ova were difficult to isolate, and the finer processes could only be seen with great difficulty through the walls of the gonozoid.

If we confine ourselves to observations that may be certainly trusted,

\* The Society are not intended to be denoted by the editorial "we," and they do not hold themselves responsible for the views of the authors of the papers noted, nor for any claim to novelty or otherwise made by them. The object of this part of the Journal is to present a summary of the papers as *actually published*, and to describe and illustrate Instruments, Apparatus, &c., which are either new or have not been previously described in this country.

† This section includes not only papers relating to Embryology properly so called, but also those dealing with Evolution, Development, and Reproduction, and allied subjects.

‡ Ber. Naturf. Gesell. Freiburg i. B., iii. (1886) pp. 1-44 (4 pls.).

we find that in sixty-six species of animals the eggs gave off two primary polar globules, and that for all these the necessity for fertilization was certain, and in most of them fertilization was observed. On the other hand we know of fourteen species, the ova of which undoubtedly produced only one polar globule, and these were without exception parthenogenetic. We cannot, therefore, but conclude that eggs that require to be fertilized form two polar globules, and parthenogenetic eggs one. The significance of these facts has already been pointed out by Prof. Weismann.\*

**Origin and Significance of the so-called free Nuclei in the Nutrient Yolk of Bony Fishes.**†—Prof. C. K. Hoffmann has a paper, largely critical and controversial, in which he deals with the observations of embryologists who have treated of the matter since the time when he asserted that these nuclei arise directly from the first cleavage-nucleus.

**Resemblance of Ovarian Ova and the Primitive Foraminifera.**‡—Prof. J. A. Ryder remarks that upon cutting sections of nearly mature ovarian ova with their investing membrane, zona radiata, in place, it was found that in quite a number of cases fine protoplasmic processes or pseudopods extended from the peripheral layer of protoplasm of the egg, through its capsule or zona, and joining the cells of the granulosa or discus proligerus. This arrangement reminded one forcibly of the filamentous pseudopods extended from a Heliozoon, or of the slender pseudopods extended through the perforations in the walls of the single chambers of *Globigerina*. This resemblance is all the more suggestive if one will compare a section of one of the chambers of a *Globigerina* made through the calcareous shell and its contained protoplasm with a similar section through the ovum of the Gar pike, where the zona is formed of pillars of homogeneous matter.

Such prolongations of pseudopods through the investing zona radiata in the case of many species of animal forms show fairly well that this must be the principal means by which new matter is taken up from without and incorporated, as there is no direct extension of the vascular system into the egg by which it can take up nutriment.

It is thus seen that the early stages of the growing ovum not only resemble some of the lower forms of Heliozoa and Foraminifera as respects the grade of their morphological differentiation, but also as to the mode in which they exhibit their nutritive or physiological activities. This resemblance is still further heightened if a form like *Arbulina* is compared with certain stages of the development of ova. It is thus seen that in many cases the ovarian germ, at least, passes through a stage which may be morphologically as well as physiologically compared with some of the lowest grades of the Protozoa.

**Inversion of the Germinal Layers in the Shrew.**§—Herr J. Bichringer reports the results of some studies on the development of the germinal layers in *Arvicola amphibius* Desm. He gives a short summary of previous investigations.

He begins with the 42-cell stage, a roundish mass without segmenta-

\* See this Journal, 1887, p. 934.

† Zeitschr. f. Wiss. Zool., xlv. (1888) pp. 517-48 (1 pl.).

‡ Proc. Acad. Nat. Sci. Philad., 1888, p. 73.

§ Arch. f. Anat. u. Physiol. (Anat. Abth.), 1888, pp. 279-86 (1 pl.).

tion cavity, and surrounded by a zona pellucida. The next stage, with 64 cells, is also without distinct cavity, and is somewhat elongated and curved. When segmentation is complete, a simple layer of cells with large nuclei is seen close under the zona pellucida. This corresponds to what Rauber described in other rodents as the "Deckschicht." It incloses a cavity filled with fluid, in which lies the mass of germinal cells. In the latter hints of separation into ectodermic and endodermic layers were discernible.

In the next stage the endoderm cells begin to broaden out as a lining of Rauber's sheath, while the ectoderm lies as a connected mass at one pole. The modification of the free germinal mass into a germinal cylinder closely united with the uterus, the invagination of the germinal layers, the changes in Rauber's sheath, &c., are discussed, and Biehringer's results corroborate those of Kupffer and Selenka. The inversion of the germinal layers in rodents is essentially similar in all forms yet investigated, but the genera vary in details. *Cavia* stands by itself; *Mus musculus*, *M. sylvaticus*, and *M. decumanus* form a group; while the inversion in *Arvicola amphibius* most closely resembles that of *A. arvalis*.

**Spermatogenesis of Mammals.\***—Prof. V. v. Ebner calls attention to a research by Prof. E. Sertoli † on the spermatogenesis of the rat, which appears to have been overlooked by many. Division was observed only in the movable cells, and that always in definite periodic order, as von Ebner has corroborated. The "nematoblasts" or sperm-cells have at first nuclei which remain unstained by safranin, and only gradually exhibit this property.

**Spermatogenesis in Guinea-pig.‡**—Sig. F. Sanfelice has studied the regeneration of the testicular cells in the guinea-pig. The testicle regenerates, not from the interstitial substance, but from the pre-existent epithelium. The germinal cells ("cellules fixes" of Sertoli, "cellules de soutien" of Merkel) take part in this regenerative process.

**Irritability of Spermatozoa of Frog.§**—Dr. J. Massart gives an account of some observations made with the object of demonstrating the irritability of the spermatozoa of the frog. They are preparatory to a future demonstration of how sensitiveness to touch aids in the penetration of the spermatozoon into the ovum.

**Development of the Axolotl.||**—MM. F. Houssay and Bataillon give an account of the formation of the gastrula, of the mesoblast, and of the notochord in the Axolotl. About twenty hours after deposition the egg consists of a sphere with two poles; one is black and made up of small cells, the other is a clear grey, and is formed of larger cells. Between these there is a segmentation cavity, but there is not yet any radical distinction between the two kinds of cells. The epiblast is, indeed, derived from both the large and the small cells, the whole peripheral layer of the egg differentiating and separating itself from the subjacent cells. After a little the epiblast divides into two layers; this is in accordance with the views of Scott and Osborn, who regard the possession of a unilaminar epiblast as a primitive condition among the Urodela. It is clear from

\* Arch. f. Mikr. Anat., xxxi. (1888) pp. 424-5.

† Rend. R. Istit. Lomb., xviii. fasc. 16, and Arch. Ital. Biol., vii. (1888) p. 369.

‡ Arch. Ital. Biol., ix. (1888) pp. 425-6. Rev. Internaz. Napoli, 1887, 1 pl.

§ Bull. Acad. R. Sci. Belg., lvii. (1888) pp. 750-4.

|| Comptes Rendus, cvii. (1888) pp. 434-6.

this description that it would be inexact to speak of epiboly in connection with the egg of the Axolotl. While this differentiation has been going on the gastrula has begun to be invaginated; the first sign of this is the appearance of a broken line; sections show that this line is a groove, and that it exists among cells not yet differentiated, or, in other words, at the dense pole of the egg. The line takes the form of a horse-shoe, and the two branches meet. In this way an invagination is produced; the segmentation cavity becomes reduced, and another cavity—which will become the mesenteron—appears, and begins to put itself into relation with the invagination. The differences between this mode of invagination and that which obtains in the Anura are pointed out.

As there is at first no mesoblast along the axial line of the body, it would seem that the notochord must be developed at the expense of the hypoblast; and this is the view of all embryologists who have written on the question, with the exception of Goette. But, a little later, the medullary plates rise, and leave between them a rounded pad. The interior of the egg is the seat of active work, and the result is that the mesoblast forms a continuous layer which passes below the axis. The authors, therefore, are of Goette's opinion that the notochord of the Axolotl is of mesoblastic origin. To avoid any verbal dispute, in face of the fact that the mesoblast itself is derived from the hypoblast, they definitely state that the vitelline cells which give rise to the notochord are first organized in the mesoblast, and do not form it directly.

In another communication\* the authors state that in the segmentation of the egg there are 2, 4, 8, 24, 32, cells; it was difficult to follow the segmentation later on. As to the fate of the blastopore which is so various among the Urodela, they find that in the Axolotl it remains always open, and becomes the definite anus; there is no neurenteric canal.

**Development of the Lamprey.**†—Herr C. Kupffer reports the results of his further study of the development of the lamprey. The material was the result of artificial fertilization. Some ova kept at Königsberg, at a temperature of 8–10° C., developed into larvæ on the 16–17th day, while others kept at Naples did the same in 8 days. In both cases the larvæ, when liberated, had reached the same stage, and measured 3 mm.

In the formation of the blastoderm there is not an "overgrowth" of one half of the ovum by the elements of the other. The outer layer of morula cells acquires epithelial characters; this begins, not at the germinal or animal pole, but at the region which is subsequently dorsal. This region appears along with the formation of a special keel or embryonic shield. Gastrulation begins before the epithelial blastoderm has quite surrounded the ovum. The blastopore appears at the posterior border of the embryonic shield.

The archenteron arises as a closed sac, with its dorsal wall directly in contact with the ectoderm, though between them a group of smaller cells is subsequently insinuated. These arise from the cells of the invaginated margin, and are not to be regarded as mesodermic. They serve for the caudal extension of the dorsal axial structures, and represent the terminal bud in Teleostei, the sickle or terminal pad of Amniota. Herr Kupffer proposes the term Teloblast.

In the lamprey no neurenteric canal is formed, the blastopore is not

\* Loc. cit., pp. 282–4.

† SB. K. Bayer. Akad. Wiss., i. (1888) pp. 71–9.

closed, but remains as anus. The teloblast lies in front of or dorsal to the blastopore, the reverse of its position when neurenteric canal or corresponding strand is formed. The teloblast is not the primitive streak, but corresponds only to its posterior end, and possibly also to the pole-cells of the mesoderm described by Hatschek in *Amphioxus*.

The spinal cord and notochord are formed together from a simultaneous activity of both germinal layers, resulting in the development of a massive double keel before alluded to. The separation and further development of both axial organs are then described.

The mesoderm appears differently in head and trunk. In the former, coelomic diverticula are formed as in *Amphioxus*. In the latter the two external layers of reserve yolk-cells form first the dorsal blocks, and then the lateral plates, the somatic before the splanchnic. The coelomic cleft appears at the same time as fore-kidney and heart. The pronephric duct is ectodermic.

The rest of the memoir is mainly devoted to a description of the development of the nerves. The optic nerve is an exception to the usual rule in this, that its ganglion appears much earlier than all the rest, and arises not from a peripheral portion of the epidermis, but from the median keel—that is, from the common origin for brain, spinal cord, and this pair of ganglia. The branchial nerves form a second series, and the dorsal spinal nerves a third.

An anterior endodermic diverticulum is protruded between notochord and epidermis dorsalwards to the brain. It forms a narrow median portion and two lateral pockets. The former represents the well-known diverticulum between hypophysis and notochord; the latter form the paired pre-oral head-cavities, which Kupffer regards as homologous with the anterior endodermic diverticula in *Amphioxus*.

**Partial Impregnation.\***—Prof. A. Weismann and Mr. C. Ischikawa report that on examining the sexual cells of certain species of *Moina* they found to their astonishment that those in which four segmental cells were already present still contained a sperm-cell. This was found, by further observation, to be a case of partial impregnation, only one of the first four segmental cells and not the entire egg-cell becoming united with the sperm-cell. In *Moina paradoxa* a spermatozoon penetrates into the region of the vegetative pole of the egg, immediately after its extrusion into the brood-chamber, where the egg is a naked sausage-shaped mass. The vitelline membrane then becomes formed and prevents the entrance of a second spermatozoon. The two polar bodies become constricted off, and the nucleus of the ovum migrates to the centre of the egg. The first two segmental cells appear, the sperm-cell always lying in the neighbourhood of the one which is nearest the vegetative pole, without, however, becoming united with it. The four-cell stage follows, and the sperm-cell is now seen to exhibit amœboid movements, and to approach a segmental cell; fusion then follows and in the next following stage, that of eight segmental cells, no sperm-cell can any longer be seen in the egg.

Since making these observations † the authors have found that, “in spite of the entire accuracy of our facts, we were mistaken as to the

\* Ber. Naturf. Gesell. Freiburg i. B., iv. (1888) p. 51. See Nature, xxxviii. (1888) p. 329.

† Translated (from a proof) in Nature, xxxviii. (1888) pp. 329-30.

explanation of the phenomenon described"; the first segmentation nucleus is here, as in all sexual cells, formed by the fusion of the nucleus of the ovum with the sperm-nucleus, and the fusion of the two cells observed at a later stage is something additional to the ordinary impregnation. They urge a number of facts in extenuation. They propose to call this additional body the conjugating cell, and at present only apply to it the epithet of enigmatical.

Hertwig's 'Human and Vertebrate Embryology.\*'—In the earlier portion of Dr. O. Hertwig's recently published text-book of vertebrate embryology, the sexual elements, the maturation of the egg, fertilization and cleavage, the development of the germinal layers, the blood and connective tissue and egg-envelopes of reptiles, birds, and mammals are described, and the formation of the organs from the epiblast, hypoblast, mesoblast, and mesenchyma. The genesis of the organs from the primary layers is admirably illustrated with special reference to its bearings on the anatomy of the adult human body, while enough data from comparative embryology are laid under contribution to give the reader a fair knowledge of the wide application of the principles laid down. It is believed that this little work will be found of great value to the medical student in understanding many questions in pathology, physiology, the structure of the brain and the mechanism of the nervous system.

#### B. Histology.†

Cells and Tissues.‡—Prof. F. Leydig has published another suggestive essay, which is based on the study of the cells and tissues of *Argulus*.

In dealing with cells he treats first of spongioplasm and hyaloplasm; it may always be considered an advance in knowledge to be able to break up into structures parts of an organism which have been hitherto supposed to be of one and the same nature. This is now the case with the cell. In 1876 the author pointed out that there might be ( $\alpha$ ) concentric striation of protoplasm, as in the ganglionic spheres of Insects and Annelids; or ( $\beta$ ) striped differentiation, which might be longitudinal, transverse, or radial; or ( $\gamma$ ) there may be plexiform differentiation of the protoplasm, as in the cell-nuclei and blood-corpuscles of *Triton*.

It is now generally recognized that there are in the cell-substance two substances; one of these forms a kind of network, and has been called the substantia opaca, the other lies in the interspaces and is soft and clear; it is the s. hyalina. With these the newer terms of spongioplasm and hyaloplasm are synonymous. Leydig has also shown that these two parts play a definite rôle in the conversion of the cells into tissues, and this has been confirmed by Rabl and by Sedgwick. *Argulus* is well adapted for the kind of investigations the author wished to undertake; for not only the eggs, but also the large cells which belong to the fat-body, and, especially, the unicellular glands show the plexiform and radiate arrangement of the spongioplasm. The space around the nucleus was distinctly observed. In the large cells of the fat-body it was possible to see numerous nucleoli without any inclosing membrane.

\* Hertwig, O., 'Lehrbuch der Entwicklungsgeschichte des Menschen u. der Wirl ethiere,' 8vo, Jena, 1887-8, viii. and 507 pp. (figs.). Cf. Amer. Naturalist, xxii. (1888) pp. 179-82.

† This section is limited to papers relating to Cells and Fibres.

‡ Zool. Anzeig., xi. (1888) pp. 254-9, 274-80, 309-15, 328-33.

Leydig knows of several cases in which whole cells have become cuticularized, and cites the jaws of *Paludina*, *Ancylus*, and *Lymnæus*.

In treating of the tissues, Prof. Leydig deals with some recent remarks of Dr. H. Eisig. As to the mode of origin of the cuticular fringe, it is to be observed that, as long as the cell-substance was regarded as a homogeneous mass containing granules, the fringe could only be regarded as a secretion of the matrix-cells; but when the difference between hyaloplasm and spongioplasm was recognized, the question arose—Is the cuticle formed by the hyaloplasm only, or does the spongioplasm take any share in it? The author believes that both take a part, but the cardinal point is that the cuticular substances are formed by the secretory and metamorphic activity of the matrix-cells. Eisig's view that the cuticle is formed by agglomeration of rod-like structures formed by glandular cells may be shown to be erroneous by the following observations:—In some German Gastropods peculiarly-formed corpuscles are to be found in the dermal glands, and the byssus, and the "bloom" on some shells, as well as the powder of some insects, are all formations of dermal glands, yet they never take any part in giving rise to the fibrous differentiation of the cuticle.

Prof. Leydig is of opinion that cuticular tissue is allied to connective tissue. This view is based on a number of observations:—

(1) The cuticular tissue forms the hard or skeletal parts of Arthropods (dermal carapace as well as skeletal parts), and represents therefore the tissue which takes its place in Vertebrates.

(2) In the form of their early development the cuticular tissue of an Arthropod and the connective tissue of a Vertebrate agree; in both cases it consists of matrix-cells and an overlying layer of homogeneous substance. Sarcolemma or neurilemma or the corium of a Batrachian larva present the same characters as the cuticular tissue of an Arthropod.

(3) The cuticular tissue of the integument is in Arthropods connected uninterruptedly with the connective tissue of the interior of the body.

(4) When the minute structure of cuticular tissue, especially that of the dermal carapace of Arthropoda, is compared with the connective tissue of Vertebrates, we find in both striated homogeneous layers and parts condensed into fibres, and in both cases there is a traversing system of lacunæ, clefts, and pore-canals.

While some recent authors have taken different views as to the structure of the dotted substance of Vertebrates from those held by Leydig, it has been a matter of satisfaction to him that the most exact (Nansen) holds his doctrine. He does not doubt that Nansen's explanation of the dotted substance as a thick plexus of very fine nerve-tubes is correct. It is clear from Leydig's earlier observations that we ought to speak of the nerve-tubes rather than the nerve-fibres of Annelids and Arthropods. In these tubes one may distinguish a spongioplasm, which forms the investment, and the hyaloplasm or inclosed soft and semi-fluid nerve-material. The former may be continued inwards as a framework. The nerve-fibres of Vertebrates also ought to be called nerve-tubes and not fibres, and in them there appear to be at least remnants of an internal meshwork. Here again the author finds matter for criticism in Eisig's latest work.

The hyaloplasm ought to be regarded as the "primum agens" in the nerve-tissue. Leydig has spoken of the spaces in the spongework as an

uninterrupted system of hollow ducts, and this agrees very closely with the view of Nansen, who regards the grey substance, as a whole, as a plexus of fine nerve-tubes. The well-known physiological phenomenon of the dependence of the parts of the organism on the nervous system is, from a morphological point of view, seen more clearly when we know that the nervous material is intermixed with the protoplasm of the cell-substance in all parts of the living body.

**Cell-division.\***—Prof. J. Arnold makes a further communication on the division of cell and nucleus in the spleen, and also discusses such processes as diverge from the typical mitosis's. He thus describes "pluripolar mitosis," "indirect fragmentation," the "homœotypic" and "heterotypic" forms of Flemming, and the pathological phases described by Rabl. The distinctiveness of indirect fragmentation is maintained, though it is not denied that transitions occur between it and the forms of pluripolar mitosis. The main object of his present contribution is to show the agreement and the difference between mitosis proper and indirect fragmentation.

**Cell-membrane.†**—M. M. Ide has investigated the nature of the membrane in the cells of the mucous Malpighian layer of the epithelium. The best material was obtained from embryonic epithelium in the skin and digestive tract.

He regards the reticulated peripheral layers of the cells as cellular membranes in the true sense, and that for two reasons: first, because they exhibit the general and typical structure of cellular membranes; and further, because they are derived from the primitive membrane of the young cells by a simple cleavage.

As to the bridges which connect the cells, he regards them as forming part of the cellular membrane. They are in substantial continuity with its reticulum; they present the same structure as its trabeculæ, and are derived, like the envelope itself, from the original membrane.

**Goblet-cells of Intestine of Salamander.‡**—Herr J. Steinhaus has investigated the so-called goblet-cells in the epithelium of the intestine of *Salamandra maculosa*. They are neither exclusively epithelial cells undergoing mucous degeneration, nor cells modified into unicellular mucous-glands. They are partly the one, partly the other. If no second nucleus be present in the cell it completely degenerates; if one be present the cell functions as a gland, and is regenerated after secretion. In forming a goblet the nucleus undergoes mucous metamorphosis; the theca is identical with the nuclear membrane, the foot of the goblet is never inclosed in the theca, but is protoplasmic to its end.

Any cylindrical cell of the intestine may become a goblet-cell, and the change, though not yet understood, is in association with physiological processes in the intestine. The more energetic the processes, the greater the number of goblet-cells. As the number increases greatly in certain pathological processes (e. g. intestinal catarrh), it is of importance to understand the conditions of the development of goblet-cells.

**Micro-Chemistry of Nerve-cells.**—Prof. M. Fleisch § sums up the results of investigations made by himself and others on the differences in the

\* Arch. f. Mikr. Anat., xxxi. (1888) pp. 541-64 (3 pls.).

† La Cellule, iv. (1888) pp. 403-33 (1 pl.).

‡ Arch. f. Anat. u. Physiol. (Physiol. Abth.), 1888, pp. 311-22 (3 pls.).

§ M'P. Naturf. Gesell. Bern, 1888, pp. 192-9.

chemical reactions of nerve-cells. (1) The specific cells of the nervous system are distinguishable, not only by their morphological characters and the number of their processes, but also by their chemical reactions. (2) The chemical differences of the nerve-cells are demonstrable by their varied characteristics in the living tissue, by their various reactions to alkaline tests, by their variable amount of free oxygen present, and by their unequal reducing powers. (3) The chemical difference is a function of the protoplasm, and not of the contained granula. (4) The chemical characters of the protoplasm of nerve-cells are different from those of all other cells in the body. The only exceptions are those chromophilous cells which from the nature of their nuclei appear to be in process of degeneration. (5) The chromophilous character is seen in the younger cells only next the nucleus, and gradually extends over the cell. The differences vary with age. The smallest nerve-cells are intermediate between chromophilous and chromophobic cells. (6) The chromophilous or chromophobic character depends on the functional import of the cells. The demonstration of change in chemical constitution in association with difference of function is the most important result.

Fr. Anna Kotlarewsky\* has continued the investigations of Prof. M. Flesch and Fr. Koneff on the micro-chemistry of the nerve-cells in peripheral ganglia. Her observations were made in part on living, in part on hardened tissues. As the result of the former, it is shown that the chromophilous and chromophobic cells of the spinal ganglia in their living state differ widely in their chemical state and in the intensity of their metabolism. It seems most probable that the chromophilous cells have a stronger alkalinity and a greater proportion of oxygen than the chromophobic elements. The latter exhibit less reducing power than the former.

Observations made on hardened nerve-cells led the author to the result that under all conditions the different forms of nerve-cells may exhibit their differences of constitution, that hardening in alkaline media is the best condition for the demonstration of the chemical differences in the body of the cell, and that the chromophilous cells show, without exception, a stronger affinity for metallic solutions than do the chromophobic elements.

The results of staining went to show that the nerve-cells have distribution of cellular substance different from that of the other tissues. The nucleus is poor in chromatin, and the protoplasm is readily stained by various reagents. It seems also possible to determine various metabolic or functional stages by fixing the corresponding morphological conditions.

**Histology of the Ovary.**†—Prof. J. Janosik has investigated the structure of the ovary in various vertebrates. He finds that the egg and the follicular epithelium have their origin in the superficial epithelium of the ovary. The structures described by Kölliker and Mihalkovics do not develop into follicles; they are merely modified medullary cords which have the appearance of follicles. They were seen in all the forms, including man, which he examined, but they do not appear always at the same stage, nor do they all attain the same grade of development. In all

\* MT. Naturf. Gesell. Bern, 1888, pp. 3-23.

† SB. K. Akad. Wiss. Wien, xvi. (1888) pp. 172-93 (1 pl.).

these ovaries, although at different and ordinarily later periods, there also appear special cells, which are the homologues of the intermediate cells of the testis. In some cases special structures, which are perhaps analogous to the adrenals, are developed in connection with the medullary cords. In all ovaries a large number of follicles atrophy; this atrophy varies in various follicles, and especially with regard to the distribution of the cells of the granulosa. The impulse to atrophy appears to arise in all cases from the connective-tissue cells of the three folliculi. The membrane which incloses the egg seems to be merely a product of the granulosa-cells.

#### γ. General.\*

**Influence of Light on Oxidation.**†—Herr J. Loeb has made a number of experiments with pupæ to test the influence of light on the processes of oxidation within the organism. He measured the variation in the expiration of CO<sub>2</sub> under different conditions of illumination.

There is no doubt that the light stimulus increases oxidizing processes. This increase has its seat mainly in the muscles, but may be observed when there is no movement, as was the case obviously in the pupæ. Moleschott's opinion that the light influenced the muscles through the central nervous system, is confirmed. In the lower animals the stimulus may be influential without the presence of eyes; in mammals light has no appreciable local influence in increasing oxidation; this is only to be observed in plants where the proportion of surface to mass is so much greater. The results of the author's experiments are summed up in two tables.

### B. INVERTEBRATA.

**Problematical Organs of the Invertebrata.**‡—Dr. A. B. Griffiths has made a chemical and physiological study of some of the problematical organs of the Invertebrata, and states the results as follows:—A. (1) The nephridia of Cephalopoda are true kidneys; (2) the renal organs of *Astacus fluviatilis*, *Anodonta cygnea*, *Limax flavus*, *Helix aspersa*, and *Periplaneta orientalis*, are analogous in function to the renal organs of higher animals; (3) the renal organs of the Lamellibranchiata and Crustacea are true kidneys; and (4) the "segmental organs" of the Oligochaeta and of the leech are renal in function. B. The "salivary glands" of the Gasteropoda and Insecta are similar in function to the salivary glands of higher animals. C. The so-called "livers" of the Gasteropoda, Lamellibranchiata, Crustacea, and Insecta are pancreatic in function.

**Distribution of Striped Muscle.**§—Prof. H. Fol discusses the distribution of striped muscular tissue in Invertebrate types. The distribution of the two kinds of muscle in the different systems in Vertebrates hardly holds good among the lower animals. In Coelenterates the striped tissue is only found in swimming forms, in the umbrella and tentacles; the same is true of Tunicata; but most of the agile worm types have only unstriped muscles. In the Arthropods, on the other

\* This section is limited to papers which, while relating to Vertebrata, have a direct or indirect bearing on Invertebrata also.

† Arch. f. d. gesamt. Physiol. (Pflüger), xlii. (1888) pp. 393-407.

‡ Proc. Roy. Soc. Edin., xiv. (1887) p. 230.

§ Comptes Rendus, evi. (1888) pp. 1178-80.

hand, no unstriped muscle-fibres seem to occur; while the most mobile organs of molluscs, the arms, the siphon, the heart of Cephalopods, the fins of Pteropods and Heteropods, do not include any truly striped fibres. But all Molluscs are not without striped muscle, for this may be seen, as R. Blanchard observed, and as the author confirms, in one portion of the adductor muscle of *Pecten*. In *Lima* also, striated fibres were seen.

### Mollusca.

#### γ. Gastropoda.

**Comparative Histology of Glandular Epithelium of Kidney of Prosobranch Gastropods.**\*—M. R. Perrier, who has already described the structure of the kidney in *Littorina*, now enters on a comparison between various allied forms. He finds that in some of the lower Prosobranchs, such as *Fissurella*, the epithelial cells are not so much differentiated as in the Limpet. As Haller has shown, the cells are all of the same kind, and all glandular and ciliated, but they differ both from the ciliated and from the vesicular cells of the higher Monotocardia, for they are large, and have no excretory vesicles. Sometimes they contain no concretions, while at others they are so loaded with them that the nucleus is invisible. The epithelial investment is of an almost diagrammatic regularity; the elements are clearly all of the same age, and one cannot distinguish between cells that have performed and others that are about to perform their function. Secretion appears to be effected by osmosis, but if the production of renal material becomes exaggerated, it is deposited in the form of small granules in the interior of the cell. There is no absolute line of demarcation between granular and vesicular cells.

A very different arrangement obtains in the higher Tænioglossata, such as, for example, *Cassidaria*. The structure of the kidney is here extremely complex. Instead of the simple lamellæ found in *Littorina*, there is a complicated network of connective trabeculæ; these are hollowed by blood-lacunæ, and invested with a continuous epithelial layer. The whole forms a thick spongy mass which leads the author to propose the term of "glande hématique." The free surface of this mass is grooved by afferent vessels, and the epithelial layer is differentiated in a remarkable way. In addition to the numerous ciliated elements, there are glandular cells, which have not, however, the ordinary appearance of the vesicular renal cells which abound in the deeper parts of the mass. The vacuole is not clear, nor does it contain a solid concretion, but is loaded with granulations which take a blue colour with methylene. They have all the characters of mucus-cells.

The numerous intermediate types found in the kidney of the Gastropoda will be described in a detailed memoir. The author differs from M. Garnault in his interpretation of the structure of the kidney of *Valvata* and *Cyclostoma*. He is further convinced of the accuracy of his views as to the mechanism of the secretion of the vesicular cells, but he does not, of course, mean that the renal cells are eternal; like the cells of all glands they become worn out and absorbed, but there is no direct connection between the secretion and the death of the cell. The gentian-violet used by M. Garnault has not a sufficient selective power;

\* Comptes Rendus, cvii. (1888) pp. 188-91.

methylene-green and picrocarmine are to be preferred. The best way to fix the cells is to place the organ for some time in a saturated solution of acetic and picric acids.

**Anatomy and Histology of *Limax agrestis*.**\*—Dr. R. Hanitsch has a contribution to the knowledge of the Slug. He is of opinion that the chief part of the movement of the radula is due to the extrinsic muscles. The roof of the mouth is provided with a jaw, the epithelium of which rests in a layer of muscle-fibres which run in longitudinal, transverse, and dorsoventral directions, and seem to enable this upper jaw to move freely in various directions. The epithelium of the kidney, unlike that of the Lamellibranchs and Nudibranchs, is not ciliated. The lobes of Semper's organ were found to be masses of pyriform glandular cells, arranged in the form of a bouquet; the pointed ends of the pyriform cells lie anteriorly, and the ends of the individual cells are continued into long canals of very small diameter, which lead to a papilla placed immediately above; each canal seems to open separately to the exterior.

The pedal gland has been lately investigated by Dr. Székely who describes its opening as being elliptical in transverse section; further back the lumen has the form of a fungus, and the posterior part is flattened and lanceolate. The floor of the duct is raised into two longitudinal folds, which are separated in the median line by a slight depression; these folds and depression are covered by ciliated epithelium; glandular cells are numerous on the ventral and lateral portions of the duct. The fine fibres which form a network at the base of the ciliated cells are regarded by Székely as connective tissue, and not nervous, and he comes to the conclusion that the pedal gland is not a sense-organ, but simply a secretory gland which furnishes the mucus necessary for creeping. Dr. Hanitsch agrees generally with the Hungarian anatomist, but he found elongated and pointed cells of apparently a sensory nature, and so numerous that he cannot accept Székely's explanation of Sochaczewer's observation, that they were accidental products. Numerous ganglion-cells were found lying beneath them, but he has not yet been able to trace nerve-fibres from one to the other. What Sochaczewer took for nerve-fibres were probably fibres of the connective tissue from the capsules which inclose the ganglion-cells.

**Anatomy and Histology of *Cyclostoma elegans*.**†—M. P. Garnault has made a detailed study of the anatomy and histology of *Cyclostoma elegans*. He begins with describing the crystalline structure of the shell. The alimentary system is then discussed; the stomach is clothed by a cuticle pierced with minute canals; all the parts of the canal have an alkaline reaction. In regard to the vascular system, he denies the existence of a clothing endothelium on the walls of the lacunæ, and regards the afferent veins as narrowed lacunæ. The venous network of the mantle is described. Sections of the superior region compared with the same in *Bithynia tentaculata* show that *Cyclostoma* has a rudimentary gill in process of disappearance. Analyses of the contents of the respiratory cavity demonstrated, even with the animal inclosed in its shell, the occurrence of gaseous interchange with the exterior.

The glandular lamellæ and very complex arrangement of the

\* Proc. Biol. Soc. Liverpool, ii. (1888) pp. 152-70 (3 pls.).

† Actes Soc. Linn. Bordeaux, 1887, pp. 1-152 (9 pls.).

secondary chambers of the organ of Bojanus are studied. The author shows that it is principally the blood from the lower parts of the body which traverses this organ. The vascular system within the organ is formed from modified lacunæ. Distributed in the kidney are cells with green concretions, and others granular and ciliated.

Careful attention is given to the course and structure of the renopericardial canal. The glandular character of the pericardial wall is noticed. Uric acid is absent from the kidney, and the author's observations on this head agree with those of Barfurth. He has also proved that neither by kidney nor by pericardium can blood flow to the exterior. The globules of the concretionary gland consist almost entirely of uric acid. The formation and absorption of the concretions is discussed. The gland has no excretory canal, is filled with bacilli, is a reservoir for uric acid, which is afterwards eliminated by the kidney. The bacilli appear to act as true symbions.

The pedal glands are next described in detail. The supra-pedal exhibits a curious histological diversity in its walls. Sections of the concave wall show a network of pericellular canals, opening on one side into the general cavity, on the other into the excretory canal of the gland. This communication between interior and exterior raises interesting morphological and physiological problems.

The anatomy and histology of the nervous system was investigated in great detail, but the results hardly admit of summary. The different forms of muscular fibre, the nerve terminations, the apparently olfactory epithelium of the tentacle extremity, the otocyst and the eye, and the special olfactory organ of Spengel, &c., are described, and the structure and development of the egg discussed. The follicular cells are not formed from within the ovum. The oviduct and uterus are fully described.

Finally, the male reproductive organs are dealt with. The spermatogenesis was not fully elucidated. The spermatocytes result from the repeated nuclear division of spermatogonia. The nucleus of the spermatocyte forms the head of the spermatozoon, after the elimination into the protoplasm of a portion of its substance.

**Effects of Lesion of Supra-œsophageal Ganglia in Snails.\*—M. L. Petit** has made some observations on the rotatory movements produced by the lesion of the supra-œsophageal ganglia in Molluscs. This group has been hitherto neglected by physiologists. The form selected for experiment was *Helix aspersa*. The animal takes about three weeks or a month to recover from the effects of the operation. A snail which had its left supra-œsophageal ganglion removed on the 26th of June began to crawl about on the 29th of July. The right tentacle was normal, and 18 mm. long, while the left was partly retracted and only 6 mm. The animal described spirals, turning from right to left, or from the uninjured towards the injured side. The removal of the right ganglion produced corresponding results. A snail which had its left cerebro-pedal-visceral connectives cut crawled about in curves, which were broken in upon by short circles, in which it turned towards the left. Five months after the operation it crawled about almost normally. When the commissure connecting the supra-œsophageal ganglia was cut the tentacles preserved their normal length; in one case the snail

\* Comptes Rendus, cvi. (1888) pp. 1809-11.

was observed to take a zigzag course, but in most cases there were curves and rings; the latter might be to the right or to the left, but either direction was constant in any given snail. After removal of both supra-oesophageal ganglia, the snail was enticed from its shell with difficulty, and soon retired again. Removal of the pedal-visceral ganglia paralysed the animal and it could no longer return to its shell; it bled profusely and soon died.

In slugs the effect of removal of a supra-oesophageal ganglion is the immediate curvature of the body from the opposite side; the head is applied to the foot, and the animal forms a ring. If it moves it turns from the uninjured towards the injured ganglion, or in the opposite direction to the snail. This difference may be due to the slugs having been examined immediately after the operation had been performed on them.

**Creeping Movements.**\*—Prof. V. Willem seeks to explain the facts that fresh-water Gastropods can glide slowly along the surface of the water, with the foot upwards, as if they were creeping along the inferior surface of a horizontal plate of glass; and that when they do so the motions of the foot are the same as when the animal is moving on a solid surface. After discussing the various explanations which have already been offered, Prof. Willem proceeds to give an account of his own observations and experiments. These have led him to conclude that the animal begins by attaching itself to the thin superficial skin which always covers pond-water, and that then it creeps along the inferior surface of a thin coat of mucus secreted by its foot. "This locomotion," he says, "only differs from locomotion on solid substances in that here the mollusc has to depend on the rigidity of the train of mucus alone, while in the other case the train of mucus is attached to a solid surface."

**Systematic Position of *Hero*.**†—M. A. Vayssière has some notes on the organization of this opisthobranch mollusc, whose exact systematic position is still a matter of some uncertainty. The dendritic form of the appendage of the edge of the mantle, which has led to the creature being placed with the Dendronotidæ, appears to be due to the action of alcohol. In life, however, these appendages are seen to be true dorsal fusiform cirri, which are arranged symmetrically by pedunculated groups on the lateral parts of the back. They have considerable resemblance to those of *Calona Cavolinii*, but there are, in addition, on the sides of the cephalic region a pair of tufts, which carry the largest number and the longest of the cirri, the posterior groups having only one, two, or three rudimentary cirri. The arrangement of the appendages shows that *Hero* is one of the Aeolididæ, and this is confirmed by the odontophore. As the radular characters of the species found in the Bay of Marseilles differ from those of *H. formosa* described by Sars and Bergh, the author regards it as a new species, to which, however, he gives no name.

**Anatomy of *Valvata piscinalis*.**—M. F. Garnault ‡ has investigated the anatomy of this hermaphrodite mollusc. He finds that the renal tube is simple above, but that the greater part is divided by a partition into two secondary tubes. Of these the right communicates with the

\* Bull. Acad. R. Sci. Belg., lvii. (1888) pp. 421-9.

† Comptes Rendus, cvii. (1888) pp. 136-8. ‡ Ibid., evi. (1888) pp. 1813-15.

pericardium by a very wide canal, which passes between the left renal tube and the dorsal wall of the pallial cavity; the epithelium of this canal has very long and powerful cilia, which are turned towards the kidney. As in *Cyclostoma*, there may be one or more rows of cells on the transverse lamellæ which project into the renal cavity. In the kidney of *Valvata* there is only one kind of cell; these are ciliated, and contain a number of very small yellowish granules. When they are about to fall away their protoplasm contains fine vacuoles. Their débris form a kind of mucus in the middle of the renal cavity, and in this their nuclei, only slightly modified, may be made out in sections. Some points raised by M. Remy Perrier with regard to the physiology of secretion are criticized.

The pericardiac epithelium is not glandular, but in the wall of the auricle there are racemose masses of cells with homogeneous contents, which absorb powerfully colouring reagents; these cells correspond almost exactly to those described by M. Sabatier in the heart of *Mytilus*, and that author is probably right in regarding them as having a secreting function.

M. Garnault's observations on the nervous system correspond pretty closely to those of M. Bouvier; neuro-epithelial cells on the part of the mantle between the gill and the body-wall appear to represent an ill-defined organ of Spengel. Neither the structure nor the innervation of the pallial filament justify us in regarding it as a gill or false gill; Moquin-Tandon was probably right in considering it to be the homologue of the pallial filaments of young *Paludina*.

M. F. Bernard has also written\* on the anatomy of *Valvata piscinalis*. The epithelial cells of the auricle described by M. Garnault are always met with in the Diotocardia, and are identical with those which Grobben has described in the Acephala. There are no arterial capillaries. The abdominal sinuses are prolonged anteriorly by several systems; there is an anterior abdominal sinus which ends near the cardia and arises from the general cavity of the body; in the mantle there is a large sinus between the rectum and the genital ducts, and there is a system of sinuses which ends in the formation of a transverse pallial vein. The whole surface of the mantle is covered by a network with distinct meshes, which connects the transverse vein, the afferent and efferent branchial veins, the circumrectal lacunæ, and a circumpallial sinus which is given off from the anterior abdominal sinus near the pericardium. At first sight this plexus appears to be formed of true capillaries, but it really only consists of lacunæ.

The gill receives its blood by a large afferent sinus, which is enlarged at the point of attachment of the organ. It differs from that of all the Diotocardia by not being prolonged behind the line of insertion into the mantle. The branchial nerve is very large, and gives off to the epithelium delicate fibres, as in *Fissurella*, and not large bundles, as in *Haliotis* and the Trochidæ.

As to the kidney, the author agrees with M. R. Perrier (see *supra*). The visceral commissure arises partly from the so-called supra-intestinal ganglion and partly from the large right pallial nerve. The visceral ganglion is to the right and at the bottom of the pallial cavity, on the œsophagus, and at the end of the right salivary gland. There are two

\* Comptes Rendus, cvii. (1888) pp. 191-4.

pallial commissures. The penial nerve arises near the right pallial, has a large ganglion at the base of the penis, and remains ganglionic to near its extremity. There is a small but distinct olfactory ganglion. On the whole the nervous system is very much like that of *Bithynia*.

The tentaculiform filament is almost identical in structure with the tentacle itself; like it, it has an axis of ramifying connective tissue, and longitudinal and circular muscular bundles, but there is only one nerve instead of two, and the blood-lacuna is very reduced. The genital organs are difficult to make out. The hermaphrodite gland produces eggs at the periphery and spermatospores at the centre; the oviduct has an important dilatation, and receives the united products of the two albuminiparous glands. Contrary to the statement of Moquin-Tandon, the author found that the genital ducts were separated.

The salivary and albuminiparous glands and all the pallial organs have only one layer of epithelial cells, and the distinction between ciliated and secretory cells may be observed very distinctly.

The zoological affinities of *Valvata* are somewhat obscure, for the various organs have points of resemblance to those of the most various Gastropods. It is clearly enough a tænioglossate Prosobranch, but it is an aberrant type in which some of the points of the organization of the Diotocardia are retained, but it is not, strictly speaking, an intermediate form.

### δ. Lamellibranchiate.

Pericardial Gland.\*—Prof. C. Grobben gives a full account of his investigation of the but little-known pericardial gland of Lamellibranchs. His memoir discusses the structure of the organ, the occurrence of concretionary deposits in other parts of the body, the function of the gland, and its morphological relations. The chief results may be condensed as follows:—

The pericardial gland occurs in numerous Lamellibranchs as an epithelial modification in two regions, namely, above the auricles and in the anterior angles of the pericardium. In the first position it is incipient in *Arca*, well developed with processes in *Pectunculus*, especially large in *Mytilus* and *Lithodomus*, but tending to degenerate in the Monomyaria—*Pecten*, *Spondylus*, *Lima*, *Ostrea*. It is more or less markedly developed in *Dreissena*, *Unio*, *Anodonta*, *Venus*, *Cardium*, *Scrobicularia*, *Solen*, *Pholas*, and *Teredo*. The glandular sacs formed by invagination of the mantle lamellæ in the anterior angles of the pericardium occur in *Unio*, *Anodonta*, *Venus*, *Cardium*, *Scrobicularia*, *Solen*, and *Pholas*, while in the series of Heteromyaria and Monomyaria they are exhibited by *Dreissena* alone. In *Pholas* the openings of the pallial-pericardial gland are lost, and the sacs exhibit a partial division, as is also seen in the auricular glands of *Arca*, *Pectunculus*, and *Lithodomus*. In *Meleagrina* there are projecting tufts on the posterior margin of the pericardial cavity.

The epithelial cells of the pericardial glands of *Arca*, *Pectunculus*, *Mytilus*, and *Lithodomus* bear flagella and contain concretions. When richly laden with the latter they are thrown off, and most probably pass to the exterior from the pericardial space via the kidneys. The function is excretory and kidney-like. The dark colour seen even when the

\* Arbeit. Zool. Inst. Univ. Wien, vii. (1888) pp. 355-444 (6 pls.).

glands are degenerate or absent may be due to excretion inside the auricles (*Pecten*, *Spondylus*, *Ostrea*, *Lima*, *Pinna*, *Meleagrina*), or to concretions in the mantle (*Arca*).

The double character of the heart-chamber in *Arca* is a secondary result of the marked development of the posterior retractor.

The ciliated funnel of the kidney is not absent in *Pecten* or *Spondylus*, and lies in front of, and dorsal to the atria.

The union of the two atria in *Monomyaria* in front of the ventricle is the same as the posterior union in *Arca*, *Pectunculus*, *Mytilus*, and *Lithodomus*, the change in position being due to the torsion of the body.

The position of the heart behind the posterior adductor in *Teredo* is due to the posterior and ventral displacement of the body. The single aorta is due to the union of the anterior and posterior. The anterior adductor is present, as in all other Pholadidæ, but is weakly developed.

### Molluscoida.

#### β. Bryozoa.

**Embryogeny of Ectoproctous Bryozoa.\***—Mr. S. F. Harmer has studied, at Roscoff, the development of *Alcyonidium polyoum*. The ova are large and contain a number of vitelline spherules, which, in the early stages of development, are found indifferently in all the cells. The segmentation is of the remarkable type which appears to be characteristic of the Ctenostomata and Cheilostomata. At the 48-stage the aboral region has two longitudinal rows of four cells, which are disposed symmetrically right and left of the median plane, and occupy the centre of the aboral surface; there is a complete circle of eight cells which surround the central group, and are themselves surrounded by a peripheral ring of sixteen cells, which are, as Barrois has shown, the commencement of the ciliated circlet. The oral half has a central group of four large cells, which are surrounded by twelve peripheral cells. The segmentation-cavity is, at this stage, relatively large, but is partly filled by four cells which are placed immediately above the central oral cells, from which they are probably derived; these four cells are the commencement of the hypoblast. At a slightly more advanced stage the blastopore appears as a well-marked depression, which is continuous with a rather irregular cavity surrounded by several large hypoblastic cells. The segmentation-cavity becomes completely obliterated by the internal cellular mass, and the various organs of the larva begin to make their appearance.

The alimentary canal of the embryo is well developed; it consists of a vast stomach, bounded by an extremely irregular epithelium; the œsophagus, which is perhaps formed as a stomodœum, has a very narrow cavity; the mouth is larger and more evident in early than in later stages. There is some reason for thinking that the region immediately behind the opening of the sucker (which is placed a little behind the middle of the ventral surface) represents the anal region. If this be really the case, the embryo is entoproctous. When the alimentary canal has acquired its maximum of development, which it does at an early stage, the cavity of the stomach may be justly called gigantic. It is not, however, easy to make out the epithelium which lines it, for it is composed of a mass of vitelline spherules enveloped in protoplasm with

\* Arch. Zool. Expér. et Gén., v. (1887) pp. 413-58 (2 pls.).

rare nuclei, or it has the appearance of a very delicate layer of protoplasm with scattered nuclei. In a word, the epithelium of the stomach is as completely different from an ordinary secreting epithelium as one can well imagine, and this fact, in connection with the diminution of the lumen of the stomach as development advances, leads Mr. Harmer to consider the alimentary canal of *Alcyonidium* as a "rudimentary organ." It is owing to the considerable amount of nutrient yolk in the egg, to the fact that development is accomplished in the wall of the body of the parent, to the extreme shortness of the free larval life, and to the degeneration of many embryonic organs during metamorphosis that the alimentary canal does not long preserve its functional form.

The groove which appears in the aboral region of the embryo, and which has been regarded by Barrois and others as the pallial cavity, has probably the function of allowing the involution of the ciliary circlet into the interior vestibule, which is formed during the process of fixation.

With regard to the much discussed pyriform organ, Mr. Harmer states that it has, at first sight, the appearance of a mucous gland, owing to the presence in its interior of a transparent substance which does not stain easily. When examined more carefully, it is seen to be composed of a series of cells closely packed together at their outer extremity, while on their inner side they are prolonged into fine processes, among which are other cells full of vacuolated spaces. It is important to note that there is no sharp limit between the pyriform organ and the central mass of nerve fibres, which are prolonged into the bases of the cells of the pyriform organ. It may, therefore, be justly supposed that the pyriform organ has a sensory function; as the larva ordinarily swims with this organ in front it is possible that its duty is to test the bodies to which the larva desires to fix itself. It may be noted that this organ has considerable resemblance to the cephalic shield described by Kleinenberg in the larva of *Lopadorhynchus*.

It is probable that the greater part of the nervous system arises from the dorsal epiblast; if this be so, the "brain" of *Alcyonidium* is the homologue of the "dorsal organ" of entoproctous Bryozoa. On this point the author discusses the views of preceding writers, such as Repiachoff and Vigelius.

It is probable that *Cyphonautes* is not an archaic larva, but rather one very much modified, in which the alimentary canal has preserved its functional forms (owing, perhaps, to its larval life being longer than that of other Bryozoa), while the oral surface is transformed into an atrium in which the pyriform organ and sucker are situated.

The descriptions given by Repiachoff of the larva of *Bowerbankia* cannot be easily brought into accord with Mr. Harmer's observations on *Alcyonidium*, unless (as is probably the case) Repiachoff's mantle-cavity is really the internal sac or sucker, and the ciliated dorsal groove the pyriform organ.

## Arthropoda.

### a. Insecta.

**Egg-membranes of Insects.\***—Dr. E. Korschelt publishes a full account of his researches on the formation of the egg-membranes, micropyles, and chorionic appendages in Insects. The *vitelline membrane*

\* *Nova Acta Acad. Cæs. Leop.-Carol.*, li. (1887) pp. 183-252 (5 pls.).

arises by the hardening of a thin layer differentiated as a fringe from the rest of the yolk. It may appear before or after the chorion, and at different stages of egg ripeness. On the growing egg it cannot be very firm, and is capable of extension.

The *chorion* is a cuticular secreted product of epithelial cells. In its young state it is soft and plastic. The chorion of *Musca* in process of being formed remained, on the contraction of the yolk, in part adherent to the latter, in part to the epithelium, and became drawn out in threads. Towards the close of its formation the chorion seems at length to become hard; it also undergoes, as the staining reactions show, some change in its constitution. In its origin it is often unequal, forming first on the inferior portion, and becoming subsequently extended upwards.

The cellular-like appearance of the chorion is deceptive. As the internal surface of the epithelial layer changes its form in the course of chorion formation, it may be the condition of manifold structures on the same chorion. Korschelt also shows that the same cells may successively produce very different substances. The close association between epithelial layer and chorion is emphasized, and numerous modifications are described.

The secretion of cuticular substance is not always confined to the free surface of the epithelial cells, but sometimes occurs on their lateral surfaces, and therefore between the individual cells. In this way flat or filiform structures are formed which are in connection with the forming chorion, and appear on the mature egg as little basket-like structures or as a network.

The pore-canals which penetrate the chorion often in great abundance have their origin from processes of the epithelial cells. By longer and stronger processes, yet essentially in the same way, arise the elongated and superiorly expanded canals of the multiple micropyles.

In a general way the origin of the chorion may be said to be the same as that of the cuticle. A marked deviation from the typical cuticular mode of formation of the chorion and its associated structures is that exhibited in the formation of the "egg-rays" ("Ei-strahlen") in *Nepa*, which take origin in the interior of modified epithelial cells. In investigating the details of this process Korschelt has been led to conclude that the nuclei exercise a direct and essential influence on the secretory activity of the cell. Two cells fuse before the formation of the rays, but the fusion is quite complete, and the process takes place not between two cells, but within a double bi-nucleate cell. This mode of formation of chitin is indeed unique.

**Antennary Sensory Organs of Insects.\***—Herr F. Ruland points out that, notwithstanding the great variations in the antennæ of Insects, they may, with perhaps one exception, be referred to a common fundamental type. The external apparatus is a more or less well-developed chitinous hair which is supplied by a branch of an antennary nerve. Free nerve-endings, such as have been described by Hauser in *Caloptenus*, *Tabanus*, *Vanessa*, and others, do not really exist.

The first function of these organs is tactile, for there can be no doubt that a large number of the structures which are found on the antennæ have this office. Some of the hairs are stronger and are articulated at their base. *Necrophorus* and *Geotrupes* have peculiar organs of this

\* Zeitschr. f. Wiss. Zool., xlvi. (1888) pp. 602-27 (1 pl.).

kind in the form of bent or straight setæ, which are very strongly chitinized, and appear to be connected with a wineglass-shaped pore-canal, by means of a chitinous membrane; the pore-canal in its narrower lower part was, as a rule, filled by a homogeneous mass, which was found to be coloured red by carmine. The olfactory organs may be in the form of cones placed on the surface or in pits; the typical structure of the former has already been investigated by Leydig in the Hymenoptera. Organs of this kind appear to be found not only in all orders of Insects, but also in Myriopoda and Crustacea; they may, therefore, be regarded as the chief form of olfactory organ among Arthropods. When the cone is placed in a pit there may be one (simple pits) or several cones (compound pits); these cones agree in all essential points with those which are set on the surface. The differences in the pits are fully pointed out.

The auditory organs are not hair-like structures; they were first distinguished by Kräpelin, who called them pore-plates; there is a firm, thick membrane, without any orifice, which completely shuts off the lumen of the pore-canal from the outer air. The author's observations on the structure of these organs confirms Kräpelin's account. When separate antennæ of Hymenoptera were boiled with concentrated potash the plates were found, after the disappearance of all the soft parts, to be completely uninjured and to still lie in their original position; this showed that they did not consist of modified nerve-substance, but of firm chitin. In *Vespa crabro* the greater part of the pore-canal closed by the plate was seen to be filled by epithelial cells; through these there extends a central nerve-cord which arises from the basal ganglion. Just below the pore-plate there is a cavity closed by two plates, which at first lie close to one another, but then separate; these are connected with a hyaline intermediate piece of the ring. It seems to be clear that the nerve from the ganglion is not directly inserted into the pore-plate, but its exact course could not be made out. As the structure of this organ forbids us from regarding it as either tactile or olfactory, Herr Ruland thinks it probable it is auditory; the form and mode of attachment of the plates are such as to adapt it to vibratory movements, and the cavity below is such as we might expect to find in an auditory organ.

The structures were also examined in Ichneumonidæ, Cynipidæ, and the Ants; in the last of which they were the most complicated. Pore-plates were also found in the coleopterous genus *Necrophorus*.

**Poison of Hymenoptera.\***—M. G. Carlet has a note on the poison of Hymenoptera with a smooth sting, and on the existence of a poison-chamber in the Mellifera. The forms examined were *Philanthus*, *Pompilus*, and others. In them the alkaline gland, which the author has already shown to be well-developed in the Bee and others, is rudimentary. These are the Hymenoptera whose incomplete poison does not kill the insects with which they provision their nest, for the purpose of feeding their larvæ with living prey. In M. Carlet's opinion it is the presence of two liquids or of one only which produces respectively the mortal poison or the anæsthetic, and not the asserted power to select the point of the body at which the Hymenopteron will sting its victim.

The poison-chamber is useful as furnishing poison immediately to the Hymenopteron, while it protects the poison from the air which would

\* Comptes Rendus, cvi. (1888) pp. 1737-40.

alter it; as it empties it is filled by aspiration. This reservoir is only found in the Mellifera, where it is necessarily correlated with the perforation syringe which forms the stinging apparatus of these Insects.

**Morphology of the Legs of Hymenoptera.\***—Prof. A. J. Cook discusses some points in the morphology of the legs of hymenopterous insects. He begins with the prothoracic legs of the honey-bee, and traces the modifications of the “antenna cleaner” throughout a series of forms. From the study of this organ alone (so persistent is the type within each family) the species of Hymenoptera might, with very few exceptions, be arranged in their respective families. The discussion of this apparatus in its details and varied occurrence forms the greater part of the paper.

**Salivary Glands of Cockroach.†**—Herr Bruno Hofer has made an intimate investigation of the structure of the salivary glands in *Blatta* and of the nature of the associated nervous arrangements.

(a) *The general structure and mechanism of the glands is first described.* Special attention is directed to the paired muscle passing from the under side of the œsophagus to the gland, and probably in part contracting the reservoir and accommodating the gland to the movements of the body. In *B. germanica* there is another muscle from the posterior end of the reservoir, which it probably serves to empty. Any connection of the salivary duct with the œsophagus is excluded by the interposition of the very massive hypopharynx. The duct opens between hypophysis and under lip, to the outer walls of which it is completely fused.

(b) *The histology of the glands is next discussed.* The formation of the secretion is apparently as follows:—In the fine protoplasmic threads of the unencapsuled cells, fine glancing secretion-granules appear; these become more numerous, form larger spherules, and replace the protoplasm; these granules must then in some way (probably by a water-stream) become soluble and diffuse into the capsules and ducts; the secretion passes from capsules to ducts, and thence into the reservoir; at the same time the unencapsuled glandular cells re-exhibit fine protoplasmic threads extending from their margin into the lumen of the gland.

The second chapter of the memoir deals with the nervous apparatus. Herr Hofer first discusses the unpaired and paired visceral nervous system, and describes the distribution and histology of the nerves. They have a double function, serving as a centre for the peristalsis of the œsophagus, and forming the innervation of the salivary glands. Passing to the more intricate question of the exact connection between nerves and glands, the author confirms the correctness of Kupffer's observation that the nerves do really penetrate into the glandular cells. He completes it in the more detailed observation that several nerve-fibrils fuse with the striated protoplasm of the encapsuled glandular cells, but do not exhibit any peculiar terminations.

**Parthenogenesis in Bombyx mori.‡**—Prof. A. Tichomiroff urges that both well-known and recent observations confirm the statement that true parthenogenesis does occur in *Bombyx mori*, though it has been recently doubted by Prof. Verson.§

\* Amer. Natural., xxii. (1888) pp. 193–201 (10 figs.).

† Nova Acta Acad. Cæs. Leop.-Carol., li. (1887) pp. 349–95 (3 pls.).

‡ Zool. Anzeig., xi. (1888) pp. 342–4.

§ See this Journal, ante, p. 571.

**Respiration of Silk-worm Ova.\***—Prof. L. Luciani and A. Piutti have made a long series of experiments on the respiratory phenomena in the eggs of *Bombyx mori*. Their general results are as follows:—The respiratory activity is usually much depressed during hibernation. Lowering of the surrounding temperature has the same effect. Dry air causes them to lose moisture, while they gain from damp. With these alterations in humidity the respiratory activity also varies. Considerable desiccation at medium temperature may cause absolute latent life. The respiratory activity of hibernating ova varies, *cæteris paribus*, with the quantity of available oxygen. Limited space brings about progressive diminution of the CO<sub>2</sub> eliminated; when too prolonged asphyxia results. During artificial incubation there is a gradual increase in the quantity of CO<sub>2</sub> developed in unit time; humidity or dryness favours or depresses activity. The curve of respiratory activity is an index to the internal rate of life or development. The respiratory ratio of CO<sub>2</sub> and O<sub>2</sub> is not constant, but is a fraction progressively increasing even above unity. "It is probable that during embryonic development there are formed, besides the formative materials, chemical molecules less oxygenated, and therefore provided with a sum of potential energy always on the increase."

**Mode of Locomotion of Caterpillars.†**—M. G. Carlet has been investigating the mode of locomotion of caterpillars. He finds that the ordinary statement that two limbs of the same pair never move simultaneously in terrestrial locomotion is incorrect. If observation is started on a caterpillar which has come to rest with its body well extended, it is found that its first movement is to detach the anal appendage and to approximate it to the one in front by contracting the two intermediate apodal rings. The four pairs of false limbs are then detached in order from behind forwards, and are at the same time pushed forwards by the extension of the two hinder apodal rings. This series of progressive movements of the rings reaches, in the form of a wave, the first two apodal rings of the abdomen, which are held in position by the appendages of the first three rings. These two apodal rings become compressed, and the fourth appendage (or one nearest behind them) is approximated to the third appendage, or one nearest in front of them. This third appendage is immediately raised, and, almost simultaneously, though successively, the second and first pairs of appendages are raised.

We can now understand why it is that the "false legs" are so strong as compared with the others; they may be appropriately called mooring legs ("pattes-amarres"), for it is they which maintain the caterpillar and order its progression. Physiologically, they are the true legs, and the true legs (or "pattes écailluses") are the false legs of the caterpillars. The author proposes to do away with the term of false legs, and to replace it by that of membranous legs ("pattes membraneuses").

The loss of hooks from the membranous legs of *Cossus* and some other xylophagous caterpillars is correlated with their habitation of trunks in which they hollow out galleries; but, as compensation, the masticatory apparatus is exceedingly well developed. The looping caterpillars loop so as to bring their remaining two pairs of membranous legs into

\* Arch. Ital. Biol., ix. (1888) pp. 319-58 (1 pl.).

† Comptes Rendus, cvii. (1888) pp. 131-4.

apposition with their true legs; this leech-like mode of progression is less satisfactory, but its defects are made up for by the protective colouring of the bodies of these caterpillars.

**Colour-relation between Pupæ and Surroundings.\***—Mr. W. White describes some experiments made by Mr. G. C. Griffiths upon the colour-relation between the pupæ of *Pieris rapæ* and their immediate surroundings.

(a) Poulton's observation that dark surroundings exercise a retarding influence upon the period before pupation is confirmed. (b) To all appearance the freshly formed pupa is *not* photographically sensitive. (c) The general results of the colours themselves also entirely confirm Poulton's observations, notably in the case of dark pupæ produced by black and of green pupæ produced by yellow. (d) The special effects of yellow surroundings in arresting the formation of dark superficial pigment, and in tending towards the production of green pupæ, were very striking, and confirm Poulton's suggestion that rays from this part of the spectrum, when predominant in the light incident upon the susceptible larva, determine the production of these results whenever green pupæ are produced by the influence of surroundings. When green pupæ of *Pieris* are produced, as in nature, on green leaves, it is probable that the effect is wholly due to the reflected yellow rays. Though these experiments do not exactly furnish materials for new conclusions, they are valuable as independent corroborations of Poulton's results.

**Aphides.†**—Dr. H. F. Kessler discusses the development and life-history of *Chaitophorus aceris* Koch, *Ch. testudinatus* Thornton, *Ch. lyropictus* Kessler, which he regards as three distinct species instead of as one (*Aphis aceris* Linné) as they have been hitherto considered.

### B. Myriopoda.

**Post-embryonic Development of *Julus terrestris*.‡**—In his second memoir on the development of the Myriopoda, Mr. F. G. Heathcote describes the development of different organs. The mode of development of the somites is essentially the same as that of *Peripatus*, for the cœlomic spaces are found to have nothing to do with the body-cavity or vascular system of *Julus*; the body-cavity is a series of spaces contained between the gut and the body-wall, and is a pseudocœle. With this general resemblance there are considerable differences in the details. In the hinder part of the body of *Julus*, that is behind the third body-segment, part of the somite is in the limbs, and part in the body; the latter passes towards the top of the nerve-cord, and not to the dorsal part of the body as in *Peripatus*; the part of the somite within the limbs, which in *Peripatus* forms the nephridium and its vesicle, furnishes in *Julus* the muscles of the limbs.

One of the most interesting points about the development of the somites is the fact that the so-called double segments have two mesoblastic segments each; this is against the suggestion of Balfour that the double segments might represent single segments which had developed a second pair of limbs, and had altered the nervous system and other organs to suit them.

\* Trans. Entomol. Soc. Lond., ii. (1888) pp. 247-67.

† Nova Acta Acad. Cæs. Leop.-Carol., li. (1887) pp. 151-79 (1 pl.).

‡ Phil. Trans., clxxix. B (1888) pp. 157-79 (4 pls.).

In the history of the nervous system we may note the appearance of a pair of cerebral grooves resembling those of *Peripatus*; they become obliterated and disappear entirely later on. Temporary cavities appear in the ganglia which disappear when the two cords unite to form one; as to the function of these the author has no suggestion to offer, but he thinks that the cerebral grooves may be for the aeration of the cerebral tissue, as they disappear as soon as the tracheal invaginations begin to be formed.

The tracheæ arise as pit-like invaginations formed just behind and a little externally to the bases of each pair of appendages; the walls are thick and composed of cells like those of the epidermis; as the pit becomes deeper it forms a kind of vesicle within the body. As this vesicle changes its form it gives off two short thick diverticula; the cells composing these break up, alter their arrangement, and form the tracheal tubes. The stink-glands also arise as invaginations.

The heart of the adult *Julus*, which has never been fully described, has two pairs of ostia in each segment; these are originally spaces left in the tubes during development; the lips of the ostia which project into the tube of the heart are formed by four peculiarly-shaped muscle-cells, which evidently control the operations of the ostium; there are two pairs of arteries to each segment, and they lead directly into the spaces of the fat-body. The internal coat of the cardiac tube is not nucleated, being secreted by the cells of the middle coat early in development; this middle coat has a well-developed muscular structure; the fibres are circular and disposed in bands, a narrow band alternating with a broad one. The heart is suspended by thin muscle-fibres which are attached to the hypodermic matrix layer; there are also muscle-fibres attached to the fat-body which probably correspond to the alæiform muscles of the heart of insects. The cavity in which the adult heart of *Julus* is inclosed is partially cut off from the rest of the body-cavity by a pericardial membrane, formed from the same network of cells which gives rise to the heart, and which is continuous with the fat-bodies.

In the formation of the eye a single ocellus appears first, and the rest are added on one by one till the full number is reached; in each case the process of development is the same. A deposition of pigment-granules of a dark red-brown colour takes place within a thickened mass, which has been formed by a multiplication of the cells of the hypodermis, and this secretion of pigment is accompanied by a separation from one another of certain cells within the mass. As a result, we have the formation of a vesicle bounded by a mass of dark pigment. The cells which compose the external wall of this vesicle give rise to the lens which fuses with the chitin of the exoskeleton, and the same cells continually add layers to the lens till it assumes its full size. This development of the eye-spots from a vesicle agrees with Patten's belief that the simple myriopod eye has been developed from a vesicle invaginated from the ectoderm; but what Patten describes as the vitreous layer is clearly the corneal hypodermis. The original hypodermis present before the formation of the eye is represented by the external chitin of the exoskeleton formed by it and now fused with the external wall of the vesicle.

With regard to the phylogeny of the Myriopoda, it is observed that the essential features which they have in common with *Peripatus*, are such as would be likely to occur in many Tracheata, if the latter are

derived from a *Peripatus*-like ancestor. The carboniferous Myriopod *Euphoberia*, as described by Scudder, presents arrangements which are found during the development of *Julus*. The Archipolypoda have the dorsal part of the body ring, which is now single, distinctly divided. It is probably best to regard each part of the so-called double-segments as a segment complete in itself, but joined to its fellow by the fusion of two dorsal plates. It seems likely that the Chilopods and Diplopods branched off from a common ancestor at some period not very long before the appearance of the Archipolypoda, and that both are remotely descended from some *Peripatus*-like stock.

### d. Arachnida.

**Anatomy of Gamasidæ.\***—Herr W. Winkler has investigated the structure of Gamasidæ, especially of the genera *Gamasus* and *Uropoda*. In regard to the general segmentation of the body, he regards the boundary of the "capitulum" as marked by a chitinous ridge which extends directly in front of the first pair of legs. As to the mouth appendages, the chelicerae are equivalent to the mandibles, for their nerves come from the sub-cesophageal ganglion, from a portion distinct from the rest of the mass. The maxillæ, lower lip, and tongue are carefully described, and their relations and modifications discussed. In discussing the other appendages, he emphasizes, against Mégnin and Pagenstecher, that the first pair are not labial palps, but true legs. The terminations are very fully described.

The cuticle with its plates and layers, the interstitial connective tissue, the musculature like that of Tyroglyphidæ, the nervous system, and the sensory bristles are then briefly described, and the author discusses the richly-branched tracheal system. The actively pulsating heart lies in the anterior half of the abdomen, above the posterior end of the mid-gut. It is one-chambered, short and broad, with two valved openings and a long aorta. It may be regarded as a reduction from the heart of Araneidæ, and between the two the hearts of Chernetidæ and Phalangidæ may be placed.

In the alimentary system Herr Winkler describes the pharynx with its six pairs of muscles, the narrow cesophagus, the wide mid-gut with six sacs and hepatic glands, the simple glandular hind-gut, and the vesicular rectum. The excretory organs are certainly homologous with Malpighian vessels. They consist of two separate long tubes, which open along with the hind-gut into a capacious collecting bladder, which is really part of the excretory and not of the alimentary system. Finally, the author describes at length the male and female reproductive organs, and makes a few notes on development.

### e. Crustacea.

**Intestine and Digestive Glands of Decapods.†**—Prof. G. Cattaneo has investigated the histology of the intestine in Decapoda, and the function of the associated glands. In the intestine of *Palinurus vulgaris* he distinguishes and describes seven layers—the chitinous cuticle, the cylindrical epithelium, the connective layer, the longitudinal muscles, the radial muscles, the circular muscles, the external connective tissue. Many types are discussed. The histological part of the research evi-

\* Arbeit. Zool. Inst. Univ. Wien, vii. (1888) pp. 317-54 (1 pl.).

† Arch. Ital. Biol., ix. (1888) pp. 255-66.

dently suffers from delayed publication, since the not very recent memoir by Frenzel on the same subject was not seen by the author until his results, which are corroboratory, were being published.

As to the function of the glands, the author demonstrated the presence of diastase, pepsine, and trypsin, of emulsifying enzymes, of pigments analogous to those of the bile. These substances were not free, but incorporated in adipose drops, which probably lose their contents in digestion and are reabsorbed.

**Effects of Lesions of the Supra-œsophageal Ganglia of the Crab (*Carcinus Mœnas*).**\*—M. L. Petit has been partly induced to study the effects of lesion of the supra-œsophageal ganglia of the Crab by their curious habit of lateral locomotion. If the animal attempts to move after the operation has been performed on the left side, it describes a series of circles in the direction of the hands of a watch, but its head is directed sometimes outside and sometimes inside the circle. It passes from one to the other of these positions by a half-turn. There is the same spoke-wheel movement which is observed in Mammals, when the brain is injured; but, whereas in them, the head of the animal is always opposite to the axis of rotation, it may be opposite to, or turned to it in the Crab. If the right supra-œsophageal ganglion be injured, the movements of rotation are in the opposite direction to those of the hands of a watch.

**Male Appendages on Females.**†—Herr D. Bergendal describes the occurrence of distinctly male copulatory appendages on female crabs. In many cases there were no appendages on the first somite of the abdomen; in other cases they were rudimentary; in others spoon-shaped; in a few like those of the male. Herr Bergendal regards this abnormality as due to inheritance from the male parent, and lays stress on the fact that only the useless and normally rudimentary first pair of appendages are thus modified, while the second pair which are functional never exhibit modification. A fuller description is in course of publication.

**Eyes of Cymothoidæ.**‡—Mr. F. E. Beddard has investigated the minute structure of the eye in certain Cymothoidæ. His chief conclusions are as follows:—

The Serolidæ and Cymothoidæ possess eyes which differ in certain important particulars from the compound eyes of all other Crustaceans as at present understood. The points of difference concern the retinulæ. Each retinula consists, in the first place, of four (*Serolis*) or seven (Cymothoidæ) elongated cells resembling those of other Isopoda; each of these cells secretes a chitinous body, the rhabdome. In *Cymothoa* (Bullar) the individual rhabdomeres retain their distinctness. In other Cymothoidæ and in the Serolidæ the rhabdomeres become fused to form an axially placed rhabdom, which has often a complicated form, and in which a large quantity of pigment is deposited. The Serolidæ (not the deep-sea species) and many Cymothoidæ possess a pair of large hyaline nucleated cells, surrounded by the other retinula cells. In the axis of these, and inclosed by them (in the Serolidæ), is a delicate fibre, passing back as far as the ommatial membrane, and expanding anteriorly into a conical body, which appears to penetrate into the axis of the rhabdom.

\* Comptes Rendus, cvii. (1888) pp. 278-9.

† Öfvers. K. Vetensk. Akad. Förhandlingar, 1888, pp. 343-6.

‡ Trans. R. Soc. Edin., xxxiii. (1888) pp. 443-52 (1 pl.).

In young specimens of *Serolis schythei* the future hyaline cells are small and granular, and inclose the extremity of this axial cone and fibres, which may be partly a product of their activity, though chiefly formed by the other retinula cells. Each retinula, therefore, consists of two central clear cells (corresponding in number to the cells of each vitrella), surrounded by four or seven pigmented cells.

The pigmented retinula cells are connected with transversely striate fibres, which pass into the ganglion, and are generally regarded as nerve-fibres. The hyaline cells do not end in a nervous filament, unless the axial cuticular rod, which is hollow, incloses a nerve-fibre. The specialization of the retinula into clear and pigmented cells recalls the eye of certain Annelids and Molluscs. The eye is 'diplostichous,' the upper row of cells forming the vitrella, and the lower row the retinula. To this extent, therefore, Mr. Beddard's results harmonize rather with those of Grénacher than with those of Patten.

**New Species of Ceponinæ.\***—MM. A. Giard and J. Bonnier have, since the publication of their monograph on *Cepon elegans*, received a number of new forms allied to that parasite. On *Nautilograpsus* there is a species which it is proposed to call *Grapsicepon Edwardsi*; it is apparently rather common. Although it does not produce any apparent deformation of the carapace, its presence can be easily enough detected on account of the transparency of its host's integument. The male is much less degraded than that of other Ceponinæ, and therein it approaches *Leidyia*. The species found on *Trapezia dentifrons* is called *G. amicum*, but unfortunately, only one example is as yet known; on the whole, however, its characters, so far as it has been possible to make them out, are rather those of members of the group which are parasitic on Grapsidæ than of the parasites of Gelasimidæ; and, as is known, it is with the former that Milne-Edwards, in opposition to Nauck, is inclined to place the genus *Trapezia*.

The name of *Portunicepon Hendersoni* is given to a parasite of *Thalamita callianassa*, which appears to be pretty common at Madras. This parasite produces a very slight deformation of the carapace; the male is very degraded, pigment being rare, and the lateral lobes of the pygidium almost fused with the median part.

*Grapsicepon Edwardsi* is the first example of a Bopyrid being found parasitic on other Crustacea than those of small bays with quiet waters, for it was brought from the Sargasso Sea. Prof. A. Milne-Edwards has lately found a magnificent Bopyrid, which it is proposed to call *Pleurocrypta formosa*, on *Ptychogaster formosus*, a splendid Galatheid, which was dredged by the 'Talisman' at a depth of 946 metres.

**Geographical Distribution of Diaptomus.†**—MM. J. de Guerne and J. Richard bring forward evidence in favour of the cosmopolitan range of this fresh-water Copepod; further investigations will probably show that many of the species already described have a wider range than is yet assigned to them.

**So-called Mucous Gland of Male Cypridæ.‡**—Herr C. G. Schwarz has investigated the structure of the so-called mucous gland of the male Cypridæ. It is, as he observes, a remarkable thing that we should be

\* Comptes Rendus, cvii. (1888) pp. 44-7.

† Ibid., pp. 47-50.

‡ Ber. Naturf. Gesell. Freiburg i. B., iii. (1888) pp. 133-58 (2 pls.).

in doubt as to the function of an appendage of the male generative apparatus which is nearly one-fourth of the size of the whole body of the animal.

In *Cypris monacha* the organ is thus constituted: it is made up of a chitinous framework, a contained glandular tube, and an investing musculature. The framework consists of a chitinous tube formed of about sixty rings connected by a membrane, and of the spines placed thereon. Every ring carries several spines, which, at the proximal and distal ends, are arranged in circlets, and are specially attached at their tips by a strong chitinous ring; while all the rest stand at right angles to the long axis these are inclined outwards, and so form funnel-like structures, in the walls of which the spines run like ribs. These spines consist of one piece, while all the rest not only divide into two arms, but each of these breaks up again into two secondary arms, which are so arranged that the last arm of one and the first of the following spine always belong to the same ring.

The chitinous tube passes at its hinder end into a knob-shaped enlargement, which very rapidly narrows to a fine efferent duct which is proportionately short, and opens into the penis; at its anterior end it passes into a shallow cup which is bored by a narrow orifice hardly wider than a spermatozoon; around the inner concave side of this small chitinous cup corpuscles are arranged. Thence a tube is invaginated into the chitinous tube; this appears to consist of a single layer of cells, but the examination of young forms teaches that the layer is double. This invaginated tube only extends to about the middle of the chitinous tube; the rest of the latter contains a secretion which is coloured a light-blue by hæmatoxylin, and which passes into the efferent duct, and, when the latter is injured, escapes as a small, mucous, and highly refractive droplet. The secretion is probably formed by the cells of the invaginated tube, for which the author proposes the term of glandular tube in place of Nordquist's name of internal epithelium; this secretion is of great importance for the spermatozoa, which, in *Cypris punctata*, were observed to be rolled up in it.

After some observations on the differences which obtain in different species, the author proceeds to inquire how the apparatus works. The activities of the muscles and of the spine-arms appear to be antagonistic, for the rings of the chitinous tube are approximated by the contraction of the muscles, while, when these relax, the elasticity of the spines must tend to separate the rings from one another. In this way the chitinous tube is alternately, and rapidly, shortened and elongated. We have, therefore, to do with a pumping apparatus, the suction-power and driving power of which are produced by the alternate action of the spine-arms and muscles. The shallow cup at the anterior end of the tube seems to act as a valve. As soon as the spermatozoon has completely entered the apparatus it must be driven out into the ductus ejaculatorius by renewed shortenings of the tube.

It may be concluded that the "slime gland" is morphologically an invagination of the vas deferens into itself; its function is to isolate the spermatozoa which lie collected in quantities in front of it, and to pump them onward. It may also, as Weismann has suggested, have some ejaculatory power.

## Vermes.

## a. Annelida.

*Criodrilus lacuum*.\*—Dr. A. Collin has made a detailed investigation of this Oligochaete. Exceptionally large specimens from the Spree were as much as 30 centimetres long, and had 450 segments. The clitellum, which has been overlooked by all writers except Dr. Benham, is not distinctly marked off, but is merely a slight swelling; its colour, likewise, differs but little from that of the rest of the body, and it is only by its histological structure that it can be recognized.

This worm has, in Berlin, as yet only been found in the Tegeler-See and in the Spree, where it lives on mud rich in organic substances. The author was able to keep specimens alive for some months in a glass basin, but they never became sexually mature; as they live, naturally, at a depth of from 8 to 10 feet, the difference in the pressure may be the cause of this. In Berlin the worm is sexually mature in June and July. The cocoons are chitinous, and about 5 centimetres long; they exhibit a slight indication of a transverse marking, which is probably the expression of the several segments of which the cocoon is formed.

The cuticle is like that of *Lumbricus*, but much thinner; there is no longitudinal or circular arrangement of the fibres, but an oblique one only; the mechanical disadvantage of circular fibres to the contraction of the longitudinal muscles is obvious. The whole of the hypodermis, especially in the hinder region, is traversed by closely set, fine, capillary vessels which aid in respiration. Between the cylindrical there are here and there filamentar cells, with a swelling in the middle, which corresponds to the position of the nucleus. Unicellular glands are not nearly so numerous as in *Lumbricus*. The hypodermis of the cephalic lobes differs somewhat from that of the rest of the body; it consists of extremely delicate cylindrical cells, which are twice as long as those of the hypodermis of other parts of the body.

A number of the cells of the hypodermis of the cephalic lobes and of the first segment are specially differentiated, and form groups of goblet-shaped cells, which appear to have a gustatory function. The circular muscles consist of flattened fibres which, in transverse section, do not exhibit any lumen; with high magnifying powers, however, a darkish line may be seen in the middle, and this indicates the lumen of the compressed tubular fibre. There are scattered nuclei, which belong to the intermuscular connective substance between the muscles. The arrangement of the longitudinal muscles of *Criodrilus* differs somewhat from that of the Lumbricidæ. Rosa has distinguished a ventral, four lateral, and two dorsal muscular bands. Dr. Collin, however, does not find any break in the median dorsal line, but only a thinning of the layer. Into the septa which separate the bundles of muscular fibres there are inserted transverse muscles, which extend to the enteric tract, and the chief longitudinal vessels. The bundles of the Lumbricidæ consist of two regularly arranged rows of muscular lamellæ, which are grouped around the central lamella, but in *Criodrilus* they consist of a number of muscular lamellæ which are irregularly scattered in the space between two neighbouring central lamellæ. The separate muscular fibres can be easily isolated by potash.

\* Zeitschr. f. Wiss. Zool., xlv. (1888) pp. 471-96 (1 pl.).

The lining of the peritoneum is a thin layer of large very flat cells, of which, in section, one can generally distinguish only the nuclei, which are placed at some distance from one another. The cœlom is only incompletely separated into segments by dissepiments, as the cavities, especially around the ventral medulla, are in communication with one another. The dorsal mesentery of *Criodrilus* appears to be aborted. The surface of the intestine and of the dorsal vessel is invested by a layer of much modified peritoneum—the chloragogue-glands. These are pyriform or saccular cells, with brown, coarsely granular contents, which, as a rule, hide the nucleus. The muscles of the dissepiments and of the cœlom extend in very various directions.

On the whole, the author confirms the description given by Vejdovsky of the structure and arrangement of the nervous system, but he was not able to detect the well-developed layer of cells which that author describes as lying on the ventral half of the ventral medulla; he finds, indeed, that the ganglionic cells are arranged in four rows; the whole of the median part of the cord is occupied by fibrous substance in which tracts, which follow various directions, can be made out. The walls of the large neural canals appear to have double contours. In the hinder part of the body there are two, but in the median part three canals, so that Vejdovsky's figure represents a section of the hinder part of the body. The median canal is at first of the same size as the two lateral, but in the median and anterior part of the body it has a considerably greater diameter. In some of his sections the author was astonished to find a fourth canal underlying the median third, with which at one point it was observed to become connected.

Around the tip of the tail there are groups of hairs, which are much longer than the setæ of the gustatory knobs. As it was often observed that worms which had extended the caudal portion for the purpose of breathing were very sensitive to sudden movements of the water, it may be supposed that these hairs are special tactile organs for the perception of movements of the water.

Like the Lumbricidæ, but unlike the Limicolæ, *Criodrilus* has a longitudinal subneural, as well as a dorsal and ventral vessel. In segments seven to eleven the lateral vessels take on the function of a heart. In the dorsal vessel there are valves, which are arranged in a segmental manner; the author does not agree with Kupffer in regarding them as blood-forming organs, but as true valves which, on the contraction of the vessels, shut off two adjoining chambers from one another, and prevent the return of the blood. In addition to the superficial capillaries at the hinder end of the body, it was observed that there is a large collection of capillaries in the hypodermis of the cephalic region, by means of which a good supply of oxygen is obtained for the brain.

Segmental organs are present in the generative segments, and this points to close relations between *Criodrilus* and the Lumbricidæ. The pharyngeal mass, which can be protruded, is provided with three strong groups of retractor muscles, but with only one protractor. The author agrees with Rosa and Benham in asserting the presence of a typhlosole, which was stated by Vejdovsky to be absent. In most points he agrees with the descriptions of the generative organs which have been recently given by Rosa, Oerley, and Benham.

In a few cases, but then in large number, the cœlom, and especially

the genital segments, was found to contain encysted Gregarines in the pseudo-navicella-stage, which resembled the *Monocystis* of *Lumbricus*.

Dr. Collin agrees with Rosa in believing that *Criodrilus* has close systematic affinities to the Lumbricidæ. Rosa's views are supported by Benham's discovery of the clitellum.

**Formation of Embryonic Layers and Cœlom of a Limicolous Oligochæte.\***—M. L. Roule has investigated the earlier stages in the development of *Enchytræoides Marionii* (sp. n.). The nutrient yolk, though abundant, is distributed uniformly through the egg, and the first two blastomeres are, consequently, almost equal. Afterwards segmentation is very irregular, but the germinal does not separate from the nutrient yolk and develops much more rapidly. In the morula-stage the outer cells form the ectoblast, and the inner the meso-endoblast; of the latter the central cells will give rise to the endoblast. There is no definite blastocœl.

At the end of the morula-stage a cavity, which is at first irregular, appears in its centre; this is the first indication of the digestive cavity; the cells which surround it become cylindrical. As the digestive cavity increases in size spaces appear in the mass of mesoblastic elements; these spaces fuse with one another, and there is thus formed a cavity which divides the mesoblast into two layers, and which will become the cœlom. At no period was it observed to communicate with the enteric cavity. As the embryo grows the cœlom increases in size; the innermost cells of the parietal layer of mesoblast proliferate, and some become free in the cavity, where they produce the formed elements of cœlom; others remain in their places and advance towards the visceral mesoblast, with which they fuse; in this way the septa which separate the segments are produced. Others of the cells of the parietal layer of the mesoblast elongate, secrete a contractile substance, which accumulates round the protoplasm which surrounds the nucleus, or become smooth muscular fibres. This mesenchymatous origin of the muscular fibres is comparable to what happens among the Mollusca; it and the absence of initial mesoblast-cells are facts which appear to be explicable by the abundance of nutrient yolk, and they must be set against the existence of initial mesoblast-cells in most chaetopod Annelids, and the epithelial origin of the muscular tissue of the adult in the Archi-annelids. It is clear from these considerations that the more or less large quantity of yolk has an influence on the mode of development of the germinal layers and of the tissues, and that consequently we cannot base the embryo-genetic relations of animals solely on their histogenetic characters.

**Nephridia of *Lanice conchilega*.†**—Mr. J. T. Cunningham gives an interesting account of the excretory system of *Lanice conchilega* Malmgren. It consists of eleven nephridia, three rudimentary, in somites 3–5; four perfect, in somites 6–9; and four imperfect, in somites 10–13. The eight posterior nephridia communicate with each other by means of a longitudinal tube formed by the fusion of their distal parts. "This," Mr. Cunningham concludes, "is the first case in which such a longitudinal coalescence of nephridia has been discovered, and its morphological similarity to vertebrates is obvious."

\* Comptes Rendus, cvi. (1888) pp. 1811–13.

† Proc. R. Soc. Edin., xiv. (1887) p. 238.

**New Enchytraidæ.\***—Dr. W. Michaelsen continues his researches on Enchytraidæ. He first describes the new genus *Sterculus*. The bristles are S-shaped; there is no head-pore; the dorsal vessel springs from the girdle segment and is associated with a heart-body; the blood is colourless; there are no salivary glands, the gut is adapted for fluid or semi-fluid nutriment, and is blind; the vasa deferentia are long. *S. niveus* n. sp. is described in detail, also *Pachydriilus sphagnumtorum* Vejdowsky, var. nov. *glandulosus*, *Mesenchytræus setosus* n. sp.

### β. Nematelminthes.

**Fertilization of Ascaris.†**—Dr. N. Kultschitzky reports in more detail the results of his investigation of the processes of fertilization in *Ascaris megalocephala*. The importance of the subject justifies a fuller summary than was possible from the preliminary communication.‡

He emphasizes the deceptiveness of using different optical appliances in the observation of these fine details, and rightly insists on the necessity of investigators noting in their researches what objectives, apertures, &c., they have used. The best fixing medium is an equal mixture of alcohol and acetic acid. Acetic ether was also utilized. For studying polar globules and pronuclei fresh material from living animals is essential. For segmentation the dead worm, not later than 3-4 hours after death, must be kept for some hours, or for a stage beyond four for 2-3 days, in damp warmth of 35-38° C. There are several advantages in inclosing in balsam instead of the usual glycerin.

The polar globule formation is accomplished after the manner of ordinary karyokinesis. By giving off minute amœboid processes, the protoplasm of the sperm is gradually reduced during the formation of the polar globules. Nor is the entire chromatin of the sperm nucleus utilized in the formation of the male pronucleus. When the second polar globule is extruded, the sperm nucleus has always a distinctly reticular structure. As it is at this stage only rarely quite surrounded by its protoplasm, it is partially in direct contact with the protoplasm of the ovum.

In the formation of pronuclei, there is no mixture of male and female chromatin. Both pronuclei arise quite independently of one another. Each consists of a tolerably firm shining achromatic sheath, of a chromatin substance lying apparently in the peripheral portions of the pronucleus, and forming there a thick network with a number of nodes, of an achromatic substance, and of nucleoli which are usually peripheral. The two pronuclei are quite homologous, they originate in a manner *sui generis*. The number of pronuclei was sufficiently noted in the previous summary.

Each pronucleus begins its karyokinetic changes independently. The coil stage, the mother aster, the metakinesis, the dyaster stage, the daughter coils, and the resting stage are described in detail. The attractive spheres of van Beneden were often observed. They belong to the protoplasm of the egg and represent the first sign of the division of the cell. Kultschitzky calls them "Richtungssonnen," and is convinced that they belong entirely to the protoplasm.

\* Arch. f. Mikr. Anat., xxxi. (1888) pp. 483-98 (1 pl.).

† Ibid., pp. 567-93 (2 pls.).

‡ See this Journal, *ante*, p. 583.

Finally, he discusses the various theories of the ultimate nature of fertilization. The essential fact is the process by which the sperm-nucleus becomes modified into an inseparable portion—a nucleus—of the ovum. The act is finished with the establishment of the male pronucleus, the rest is developmental. The *punctum saliens* is the modification of the nucleus of the sperm-cell into a nucleus of the ovum, and not in a replacement of extruded portions of the germinal vesicle by the male pronucleus. No fusion of pronuclei was observed.

**Structure and Position of Gordiaceæ.\***—Dr. L. Camerano discusses the structure of adult free-living species of *Gordius*, gives an anatomical diagnosis of the genus, and debates the question of their systematic position. Villot regards them as an order of Nematelminthes, Vejdowsky places them as an independent order of "Nematomorpha," and considers them as degenerate Annulata. The author maintains their close affinity with Nematoda, connecting them with Acanthocephala, Kinorhyncha, and further back with the Protoannelids.

**Structure and Development of Heterodera Schachtii.†**—Dr. A. Strubell has investigated the structure and development of this nematode parasite of the turnip. He has no doubt that during its life-history this creature not only passes through a metamorphosis, but through one which is more complicated than that of other round-worms, and which is of a very extraordinary character. The first larva, which has externally the appearance of a nematode, is capable of movement, and lives freely in earth, is succeeded by a second form in which the sexual characters are also not marked, but which is sessile and parasitic, and of a plump appearance. The female generative forms never become developed beyond this stage; they remain all through their lives in a larval condition. In the male, on the other hand, the second larval stage appears to be followed by a period of quiescence, after which the mobile sexual form appears, with a partial fresh formation of organs, and a further development of the rudiments of the generative apparatus.

Notwithstanding the observations of Leuckart, which have demonstrated the unexpected variability of the nematode type, and have proved the existence of heterogeny, no form has yet been described whose history can be compared to that of *Heterodera*. The closest resemblance is perhaps established by *Echinorhynchus*, for in them, as in *Heterodera*, there is a pupal stage, during which the old larval skin incloses the new worm like a cyst. But *Echinorhynchus* has no second larval form, the embryo, after a brief period of wandering, passing into the quiescent stage. The only parallel to the otherwise isolated history of *Heterodera* is to be found in some Insects, and particularly among the Coccidæ, which also lead a phytophagous life. In them there are two larval stages with similar biological characteristics; the first larval form is freely mobile and of an elongated form, while the second is incapable of movement and is plumper. In the Coccidæ the females likewise retain their larval characters, remaining sessile at one spot, and forming a brood-capsule which protects the young. The male has a somewhat similar history to the male of *Heterodera*, for, after a pupal stage, in which no nourishment is taken, an agile creature is produced, provided with all the attributes necessary to copulation.

\* Arch. Ital. Biol., ix. (1888) pp. 243-8.

† Leuckart and Chun's Bibliotheca Zoologica, ii. (1888) 52 pp., 2 pls.

The author is careful to point out that, in this comparison, he is speaking only of resemblances, and does not suppose that there are close relations between the Nematode and the Insect. The parallelism in life-history is due to similarity in external conditions. Both forms lead a parasitic life, and both have adapted themselves to its requirements.

The author deals in detail with the structure of the male, of the female, with the embryonic and the post-embryonic development. All the forms, except the pregnant females, are of microscopic size; the free-living larvæ were found in sufficient numbers in the earth, sticking to the root-fibres. The best media for investigations were found to be a 1/2 per cent. salt solution, or egg-albumen; to stop their movements the animals were slightly warmed over a spirit-lamp, and were thus extended though not killed.

**Integument of *Heterodera Schachtii*.**\*—M. J. Chatin has investigated the structure of the integument of *Heterodera Schachtii*, and the modifications which it undergoes in fertilized females. In a young adult female the integument is formed of a cuticle with a hypodermis, which invests the musculature of the body. The superficial layer of the cuticle is striated, and the deeper layer is fibrillar. The former is transparent, refractive, and capable of resisting most chemical agents, and above all alkalis; its elegant circular striæ are due to the presence of ringlike elevations, which are separated by fine grooves. The hypodermis is formed of a granular layer in which there are well-marked but not very numerous nuclei. Immediately below it there are thick layers of muscular tissue. The first change which is observed as a result of fertilization is a diminution in the number of the nuclei of the hypodermis, which at the same time becomes clearer. As the female increases rapidly in size, the muscular layers become more and more delicate, and undergo a sort of delamination. Later on their retrograde change is marked by others which obtain in the hypodermis. In that layer the number of nuclei increases remarkably, and with the proliferation which obtains there is also to be noted the appearance of viscous and refractive droplets, which collect at the surface of the cuticle. This exudation does not escape by cutaneous pores, of which there seem to be none, but by local ruptures of the cuticle, which yields to the enormous growth of the body distended by ova.

The muscular layers disappear, sometimes a vestige being left in the form of a delicate band attached to the hypodermis, which becomes very delicate, and tends to fuse with the cuticle. If the ova are set at liberty directly, the cuticle breaks at several points and follows the other tissues of the integument in their fate of disintegration.

The facts just detailed show that those histologists have erred who have refused to distinguish sharply the integument from the musculature. Some of the changes that are undergone recall the phenomena of histolysis in other Invertebrates. The brown cyst which is sometimes formed for the eggs, being constituted by the exudation from the hypodermis, is neither a new pathological form nor an induration of the integument of the worm. As a measure of prophylaxis it would be well to look for mothers with disorganized integuments.

\* Comptes Rendus, cvii. (1888) pp. 139-41.

*Echinorhynchus* parasitic in Man, and whose intermediary host is a *Blaps*.\*—Prof. B. Grassi and Sig. S. Calandruccio find in Catania that not only is the *Echinorhynchus gigas* widely disseminated (being found in 40 per cent. of the pigs slaughtered), but also another *Echinorhynchus* in the small intestine of the dog, and a third in the intestine of *Mus decumanus* and of *Myoxus quercinus*. Of this last, which is identical with *Echinorhynchus moniliformis* Bremser, and has also been found in *Arvicola arvalis* and *Cricetus vulgaris*, the most important characteristics are given. Greatest length of the female, 7–8 cm.; of the male, 4–4½ cm. Diameter 1–1½ mm. The anterior extremity is somewhat tapered, and the body is marked by a series of constrictions, so that it seems divided into segments, except near the tail, which in the female is smooth for the last two centimetres, and for the last one in the male. Length of proboscis is 425–450  $\mu$ , and its breadth, 176–190  $\mu$ . The hooklets are arranged in the proboscis in a quincuncial manner (not always evident), and form fifteen transverse and fourteen longitudinal rows. Each hooklet is much curved. The lemnisci are more than 1 cm. long, and 169  $\mu$  thick. In the vascular apparatus are many annular vessels, which encircle the body. The bell-like bursa of the male is visible to the naked eye. The eggs are elliptical, 85  $\mu$  long and 45  $\mu$  broad. They have three investments: a thin outer yellowish shell; a middle thick, colourless, and homogeneous one, which is without the hollowings characteristic of *Echinorhynchus gigas*; the innermost is likewise colourless, pretty thick, and extensile. In its posterior two-thirds the embryo shows a transverse striation, and is beset with points, which towards the anterior end increase in size and become hooklets, of which at least four are distinguished by their greater size (17  $\mu$ ).

The *Echinorhynchus* just described inhabits the small intestine, and principally its upper two-thirds. The common beetle *Blaps mucronata* Lat., is the intermediate host. The authors have thrice found more than a hundred young of *Echinorhynchus moniliformis* in a single *Blaps*. The young *Echinorhynchi*, easily visible to the naked eye, were encysted, had the same characteristics as in the adults, and were oval in shape, their long axis being about 1100  $\mu$  with the investment, and without it 600  $\mu$ . Some of these young *Echinorhynchi* were given to a young rat, and others were swallowed by one of the authors, Dr. Calandruccio. This was done on December 26th, 1887, and on January 10th, 1888, numerous *Echinorhynchi*, 1 cm. long, were found in the intestine of the rat. On January 15th Sig. Calandruccio was seized with severe pains in the abdomen, accompanied by occasional diarrhoea, buzzing in the ears, malaise, and drowsiness. On February 1st a few *Echinorhynchi* were found in the fæces, and by February 13th the symptoms became so severe that he was forced to take *Extr. Fil. liq.* This was followed by the expulsion of 53 *Echinorhynchi*, chiefly female, and in a few days he became quite well, and no more ova were found in the fæces. From this it will be seen that a parasite of *Mus decumanus*, *Echinorhynchus moniliformis*, is capable of developing in man.

*Ankylostomum duodenale*.†—Herr O. Seifert continues his study of *Ankylostomum duodenale*, the occurrence of which as a human parasite makes it an important subject of research practically. After giving an

\* Centralbl. f. Bakteriol. u. Parasitenk., iii. (1888) pp. 521–5 (7 figs.).

† Verh. Phys. Med. Gesell. Würzburg, xxi. (1888) pp. 283–94 (1 pl.).

account of its general occurrence, the author notes its special prevalence in the tile-works near Cologne, and points out how its local distribution shows that the encapsuled larvæ passed from the clay, by way of unwashed hands and the like, to their human hosts. Several obvious hygienic precautions are suggested, the symptoms of the disease are described at length, and the mode of treatment noted.

The observations of Leichtenstern as to eggs and larvæ are corroborated. The mature animals are more abundant in jejunum and upper regions of the ileum than in the duodenum. They attach themselves to the mucous membrane, and suck blood. The number present varies from 15-3000. The differences between the sexes and some of the prominent features are then described. The average length of life is five years.

**Gape Worm of Fowls.\***—Lord Walsingham calls attention to Dr. H. D. Walker's recent paper † on the Gape Worm of Fowls (*Syngamus trachealis*). The American naturalist claims to have discovered that the common earthworm (*Lumbricus terrestris*) is the intermediate host of this parasite, and suggests the use of common salt on infected poultry runs with the object of destroying the hosts. This theory is strongly supported by the experience of game preservers; those who have fed birds with food carefully moistened with pure spring water only have had good results, though they have not always escaped from attacks of the disease. Dry summers are always much more favourable for rearing pheasants and partridges than those in which there is much rain; as everybody knows, earthworms do not come to the surface so long as the ground is dry and hard, but when it becomes sufficiently moistened they reach the surface, and all species of birds of which they form a natural or favourite food are eager to seek and devour them. Notwithstanding the incredulity with which Dr. Walker's results have been received in America, Lord Walsingham thinks that men with field experience will be inclined to endorse them.

#### δ. Incertæ Sedis.

**Asplanchnidæ.‡**—M. J. de Guerne takes the opportunity of having to describe a new species (*A. Imhofi*) of *Asplanchna* from Lagoa Grande, to write a monographic note on this family of Rotifers. The other new species described are *A. Herricki*, *A. Krameri*, and *A. Girodi*. A key-table of the known species is given, the characters of the masticatory apparatus being taken as one of the most important aids in distinction. A new genus (*Asplanchnopus*) is proposed for *Brachionus multiceps* of Schrank. The author is of opinion that the genus *Ascomorpha* should not be placed with the Asplanchnidæ; it has only been so assigned because of the absence of an anal aperture, but this is a character due to adaptation to a peculiar mode of life, and if generally adopted, would lead to a very incorrect idea of the relationship of Rotifers. In *Ascomorpha* the mastax is feeble, and the form and appendages of the stomach are very peculiar; for the present it had better be left among the forms *incertæ sedis*. The synonymy of the three known species is given.

\* Nature, xxxviii. (1888) pp. 324-5.

† Bull. Buffalo Soc. Nat. Sci., v. (1886-7) No. 2.

‡ Ann. and Mag. Nat. Hist., ii. (1888) pp. 28-40.

## Echinodermata.

**Nervous System of Echinodermata.\***—Dr. C. F. Jickeli deals, in his second preliminary communication, with the nervous system of Asterids. He is able to confirm the chief results of preceding inquirers. The ambulacral nervous system, in the region of the mouth, exhibits a distinction of the parts of the masses of nerve-fibres; the ventral longitudinal fibrous masses of the radial ambulacral nerves pass into the circular fibres of the oral ring. If a transverse section be made through an ambulacrum of *Asterias rubens* close to the mouth, fibres are found in the dorsal part which run parallel to the direction of the section, while ventrally there is a rounded body made up of fibrils which have been cut across. In *Stichaster roseus*, a separation of a ventral from a dorsal mass may be made out throughout the whole length of the ambulacral nerve.

The subepithelial plexus is much more highly differentiated than has been hitherto supposed. Lange's nerve is seen in cross sections to be a paired thickening of the ventral wall of the perihæmal canal. Careful histological investigation shows that it is made up of a delicate flattened epithelium which invests the whole of the perihæmal cavity, of large ganglionic cells lying directly beneath this, and having their processes woven into a fibrous layer, in which separate ganglionic cells are imbedded, and of a lamella of connective tissue which forms a partition between the ambulacral nerves and those of Lange. The latter accompany the ambulacral nerves along the groove, and take part in the formation of the oral ring. Between two successive ambulacral plates the nerve extends, with a continuation of the perihæmal canal, as far as the adambulacral plate, where it forms a swelling; from this a cord may be traced into the fibrous mass of the muscle between the ambulacral and adambulacral plate; in some cases, e. g. *Luidia Sarsi*, it may be traced on to the neighbouring parts of the body-wall.

Dr. Jickeli announces the discovery of a fourth system of nerves, which forms a layer of fine fibrils intermixed with stellate cells at the base of the epithelium of the digestive tract. This was best seen near the anus of *Astropecten andromeda*.

## Cœlenterata.

**System of Siphonophora.†**—Prof. E. Haeckel proposes a new theory to explain the organization of the Siphonophora. This he calls the medusome theory.

(1) The primary larva which first arises from the gastrula of the Siphonophora is always a simple medusa-person. It may be more or less modified cenogenetically, but it has always great palingenetic significance.

(2) This primary larva appears in two essentially different forms which may be called the *Disconula* and the *Siphonula*; according to the presence of one or the other we have the two subclasses of Disconanthæ and Siphonanthæ.

(3) The Disconanthæ, which contain the single order of Chondrophoridæ or Porpitaridæ, are developed from the regular and octoradial

\* Zool. Anzeig., xi. (1888) pp. 339-42.

† Jenaische Zeitschr. f. Naturwiss., xxii. (1888) pp. 1-46.

medusa-larva *Disconula*; it has a marginal circle of tentacles throughout life, and produces the persons of the colony by budding from the subumbrella.

(4) The Siphonanthæ, which include the Calycephoridæ, Physophoridæ, Pneumatophoridæ, and Aurophoridæ, have as a primary larva a bilateral medusa, which is distinguished by a ventral umbrella-cleft, and the possession of a single tentacle (*Siphonula*). The persons of the colony are produced by unilateral budding from the gastric wall of the manubrium.

(5) The primary larva of the Disconanthæ is to be regarded as the ontogenetic repetition of a common and archaic octoradial stem-form (*Archimeda*), and its phylogenetic origin is probably to be sought for among the Trachomedusæ (*Trachyemidæ*, *Pectyllidæ*).

(6) The primary larva of the Siphonanthæ is to be regarded as the ontogenetic repetition of a common archaic bilateral stem-form (*Protomeda*), whose origin is probably to be sought for among the Anthomedusæ (*Codonidæ*, *Euphyridæ*).

(7) All the parts which arise by budding from the primary larva of the Siphonophora are either medusiform persons or special organs thereof.

(8) All the organs which primitively belong to a medusa-person may be comprehended under the medusoma, and that whether they arise from a common basis on the trunk, or separately in various places, in consequence of cenogenetic migration or dislocation. The multiplication of separate equivalent parts (such as nectophores or bracts) are not to be regarded as multiplication of persons or medusome, but merely of organs.

(9) Although the medusome arises under two distinct forms these cannot be sharply separated from one another; in the paligenetic medusomes the chief organs remain more or less in their primitive connection (as, for example, in the gonophore of *Eudoxia*); in the cenogenetic medusomes the primary organs are more or less dislocated, as in the sterile medusa of *Eudoxia*.

(10) The lateral budding of the secondary medusomes (appendages) on the trunk may be solitary or in groups; the name of cormidia is given to the groups which are composed of several medusomes.

(11) The cormidia are primitively simple segmental repetitions of a medusome-group in metameric succession, which are separated by free internodes (cormidia ordinata) as in the *Eudoxiæ* of the Calycephorida, &c.

(12) By the breaking up of such primitive cormidia there arose those centralized cormi in which the persons bud at various points of the trunk; in this way the several organs become separated from one another (cormidia dissoluta), e.g. *Agalmopsis*, *Polyphyes*.

(13) The retrograde development of the several medusomes and their dislocated organs is of very great significance in the development of the Siphonophorous colonies, and is greater proportionately to the centralization of the cormus.

The several points here noted are then treated separately and in more detail. Notes then follow on monogastric and polygastric cormidia, on the stem or trunk, the nectosoma (or swimming body), and the siphosoma (or nutrient body), the nectophores or swimming bells, the pneumatophore or swim-bladder, and the aurophore or air-bell;

there may be one or more siphons. The palpones or tactile organs, the cystones or anal bladders, the seizing organs and touch-filaments, the bracts or covering pieces, the gonostyle or generative stalk, and the gonophores or generative persons are all separately dealt with. The Disconanthæ have one order, the Disconectæ, in which the family Discalidæ is new. Among the Siphonanthæ we have the Calyconectæ as the equivalent of the Calycophoridaæ, the Physonectæ for the Physophoridaæ, and the new order of Auronectæ, and the Cystonectæ, which are equivalent to the Pneumatophoridaæ.

**Life-history of *Epenthesis McCradyi*, n. sp.\***—Prof. W. K. Brooks describes the life-history of an interesting Hydro-medusa (*Epenthesis McCradyi* n. sp.), remarkable and indeed unique in the possession of “buds which, like egg-embryos, recapitulate, in their own ontogenetic development, larval stages which their parent has already passed.”

The medusa carries on its reproductive organs campanularian hydroid blastostyles, inclosed in chitinous gonangia. These do not multiply by budding or form hydroid corals, but produce medusæ by budding.

The ectoderm of the blastostyle is produced by ordinary gemmation, and is directly continuous with the ectoderm of the medusa. The endoderm has no direct connection with that of the medusa, though the germ cells from which it arose were probably in remote origin endodermic. The germ cells form the endoderm of the blastostyle by a process of specialization like that which Metschnikoff has described in *Cunina* as sporogenesis. The blastostyles and their medusa buds have no direct nutritive communication with the medusa. They are parasites upon the tissue of its reproductive organ.

The Eucopidæ, to which *Epenthesis* belongs, is not among the families in which proliferous medusæ are common. Haeckel doubts the occurrence of budding in the family. The new species under discussion, however, certainly produces buds, and it is very probable that another species, *E. folliata*, multiplies asexually by fission. Brooks notes that his drawings (made in 1881) of *E. folliata* in all essential particulars duplicate those recently published by Lang in regard to his *Gastroblasta raffaelii*. “It is not improbable that *Gastroblasta raffaelii* is also an *Epenthesis* which in addition to this power (of multiplying by fission) is also able to build up, by incomplete fission, polygastric medusæ of considerable size.” Just as Lang pointed out how his species illustrated the way in which a form like *Porpita* may have been evolved from a polygastric medusa, so Brooks notes that *Epenthesis McCradyi*, with its pendant blastostyles hanging from a swim-bell and carrying medusa buds, stands in a somewhat similar relation to the ordinary Siphonophores.

**Arachnactis and Cerianthus.**†—Prof. C. Vogt has no doubt that Mr. Alexander Agassiz is wrong in thinking *Arachnactis* to be a larval form of *Edwardsia*. It is an Anthozoon which swims about during the whole of its life, exhibits in its organization a well-marked bilateral symmetry, and is closely allied to the Cerianthidæ. *Cerianthus* is an animal which is strictly bilateral in its symmetry, for its body is divided

\* Stud. Biol. Lab. Johns Hopkins Univ., iv. (1888) pp. 147-62 (3 pls.).

† Arch. de Biol., viii. (1888) pp. 1-41 (3 pls.).

into two identical halves by a plane which passes through the axis of the body, the buccal cleft, the unpaired tentacles and ventral chamber, the groove between the two continuous septa, and the dorsal chamber of multiplication. This symmetry is due to the primitive formation of the unpaired ventral chamber and the two (buccal and marginal) unpaired tentacles: it is continued, during life, by the formation of new septa and cavities, with their external or tentacular and internal or mesenteric appendages, from a single median point whence the products pass towards either side. Though the ventral chamber undergoes no change, the dorsal one is repeatedly subdivided owing to the formation of new internal septa. *Arachnactis* and *Cerianthus* appear to be the only living Anthozoa which preserve this bilateral symmetry intact during the whole of their lives. In others this symmetry is affected by the growth of new septa from other points of the periphery of the body.

The Cerianthidæ may be defined as free Actiniæ with persistent bilateral symmetry, a terminal pore leading into the general cavity, a large buccal disc, surrounded by two circlets of tentacles, marginal and buccal, which are separated by a wide smooth peristome. The tentacles are arranged by pairs in such a way that a tentacle of each kind opens in each lateral chamber. The septa do not reach to the floor of the general cavity, with the exception of the two which correspond to the unpaired tentacle, and these form an internal groove which leads to the pore. The genus *Arachnactis* (Sars) has a rounded body, a few tentacles, and short similar septa; the animals are pelagic and swim by means of vibratile cilia. *Cerianthus* (Delle Chiaje) has an elongated body which is surrounded by a sheath formed by mucus and nematocysts; the tentacles are numerous; the short septa are either sterile or reproductive. The animals live in tubes at the bottom of the water. *Bathyanthus* of Moseley is regarded as a doubtful genus.

The observations of Lacaze-Duthiers have shown that bilateral symmetry is characteristic of larval Anthozoa, and is a point of great importance. Such forms as retain it throughout life may be justly regarded as presenting a primitive arrangement. Haime drew attention to the resemblance between *Cerianthus* and the rugose corals; these palæozoic forms reached their highest development in the Silurian period. Another point to be noted is that the development of *Arachnactis* is continuous, and that there is no intermediate secondary stage.

There is a certain primitive conformation common to the Anthozoa and the Acalephæ among the Medusæ, whence *Arachnactis* goes off in one and *Pelagia* and its allies in another direction. But they always remain free, and produce ova and larvæ in that condition. In most Anthozoa and Acalephæ there is a more or less well-marked period of fixation, due to different causes, and characterized by the asexual production of buds. Now, no one will deny that the primitive and ancestral form of the Anthozoa was an animal swimming freely in the sea, provided with an invaginated buccal tube which is retained in that position by vertical septa developed symmetrically on either side of the buccal cleft; this bilaterally symmetrical form produced eggs and not buds, and the young grew up directly into the likeness of their parent. Nor will any one deny that the fixed state is secondary and is generally characterized by asexual modes of reproduction.

If an Anthozoon had produced medusoid buds it would, on the analogy of our explanation of the morphology of the Hydrozoa, be said that the fixed stage was the primitive, ancestral, and normal.

At this the author stops, but it is not difficult for the reader to see the significance of these considerations.

**New Type of Anthozoa.**—M. C. Viguier describes,\* under the name of *Fascicularia radicans*, a new type of Anthozoa which was collected in the port of Algiers. The single specimen was a female colony which formed a fixed network of anastomosing stolons from 3 to 6 mm. wide. The polyps which rose from these had, when completely retracted, very much the appearance of those of *Paraleyonium*; when expanded, however, they were seen to be very different. The polyps of the new form are entirely distinct from one another, and their separation is very strongly marked by white lines, formed by the spicules which lie at the top of the septa between the polyps. The common wall which surrounds the cluster of polyps is supported by a palisade of long white spicules, which are set vertically. The free portion of the polyps may expand to twice the height of the basal column or to a length of from 16 to 18 mm. The number of polyps in one cluster is not more than ten or twelve. The author proposes to form for the reception of this new type a sub-family of Fascicularinæ, intermediate between the Cornularinæ and the Aleyoninæ.

M. Lacaze-Duthiers† thinks this new type is his *Paraleyonium edwardsii*.

‘Porcupine’ Pennatulida.‡—Prof. A. Milnes Marshall and Mr. G. H. Fowler report on the Pennatulida dredged by H.M.S. ‘Porcupine.’ The collection included seven genera and nine species, of which one genus (*Deutocaulon*), and one variety (*candida*) of *Pennatula phosphorea* are new to science. Kölliker’s classification is followed, though not regarded as satisfactory, e. g. in the wide separation of Protocaulidæ and Virgularidæ. Descriptive notes are given in regard to *Pteroides griseum* Köll.; *Pennatula phosphorea* L. var. *aculeata* Köll.; var. *lancifolia*, sub-var. *variegata* Köll.; var. *candida*, n.; *P. rubra* Ell.; *Scava glacialis*, var. *alba* Kor. and Dan.; *Funiculina quadrangularis* Pall.; *Kophobelemon stelliferum* Müll.; *Deutocaulon* n. g., *D. hystericis* n. sp.; *Protoptilum carpenteri*.

*Deutocaulon* is intermediate between the simple *Protocaulon* and such forms as *Cladiscus* and *Scava*. It is defined as—Pennatulida ex familia Protocaulidarum, quorum autozooidea, singulatim orta, pennæ laterales fiunt; calyx nullus; axis cylindricus.

#### Porifera.

**Natural History of Siliceous Sponges.**§—Prof. F. C. Noll, in the first of his essays on the natural history of siliceous sponges, deals with *Desmacidon Boscii* Noll from the coast of Norway, and makes some observations on *Craniella carnosa* and *Spongilla fragilis*. The new species is about 6 cm. high, and from 5 to 6 mm. thick; it is of a greyish-yellow colour, and becomes whitish-grey in spirit. There are a large

\* Comptes Rendus, cvii. (1888) pp. 186-7.

† Loc. cit., p. 215.

‡ Trans. R. Soc. Edin., xxxiii. (1888) pp. 453-64 (2 pls.).

§ Abh. Senckenberg. Nat. Gesell., xv. (1888) pp. 1-58 (3 pls.).

number of oscula, which are found on both sides of the sponge, and which vary a good deal in size. No afferent pores could be detected on the surface of the sponge. There are various forms of siliceous structures, into the detailed account of which the author enters very fully. He discusses also their mode of growth, and comes to the conclusion that the skeletal spicules probably grow by apposition, while those of the cortex are not essentially increased in size by such process.

Prof. Noll was unable to make out the ectoderm, but he ascribes this to the mode of preparation, as he does not accept the doctrine of Götto that the ectoderm of all sponges is lost during metamorphosis, and he brings evidence afforded by his own observations on *Spongilla fluviatilis* as opposing it. The surface of the *Desmacidon* is thin and transparent; it generally lies close to the parenchyma, and cannot be easily torn off in large shreds. Sometimes the layer appears to be merely formed of a homogeneous ground substance with a few cell-nuclei, but in other cases there are cellular elements, some contractile fibres, or non-nucleated fibres. Where the clear ground-substance is predominant, numerous cell-nuclei of various sizes are imbedded in it; these do not colour strongly, and never lie so close to one another that their boundaries touch. The non-nucleated fibres generally lie close to one another and form bands which run in various directions. The contractile fibres appear to be the elongated terminal poles of long spindle-shaped cells; the nuclei of these cells are oval, and the cell-contents finely granular. One would be inclined to speak of these as muscle-cells, if they could be shown to be provided with nerves. In any case it is possible that they have some reflex activity, and changes in the form of the surface of the sponge may be often observed.

Around the osculum there is a circle of the so-called muscle-cells, and by their elongation the orifice could certainly be narrowed. The contractile fibres are wanting in the neighbourhood of the smaller openings which serve as incurrent orifices.

The parenchyma is very well developed, and forms the chief part of the sponge; in it the cellular elements are predominant, and the ground-substance is considerably reduced; compared with those of *Spongilla*, the cells are proportionately small, but they vary considerably in form and size. Non-nucleated protoplasmic corpuscles make up the chief part of the parenchyma; between them a number of free cell-nuclei are to be seen in the parenchyma, and these are all spherical in form. Complete cells with protoplasm and nucleus, but in all cases without a membrane, are not so numerous as the bodies just mentioned. Occasionally there are two nuclei in one cell; wandering cells are also to be seen, and they may or may not have a nucleus; indeed, it might almost be thought that the nuclei and protoplasm of the cells can lead an independent life.

With regard to the formation of spicules, the author concludes that definite cells are set apart for the purpose; these silicoblasts elongate, their contents clear up, and the central filament first appears. As the delicate membrane of the body of a Rhizopod conditions the form of the calcareous shell, and as the test of the diatom is preformed by the delicate cell-membrane which serves as its basis, so we may, with Bowerbank, call the central filament a membrane formed internally by the cell. Its form depends on that of the silicoblast, and so we see the spicular mother-cells of the spicula of *Spongilla* elongate like the

spicules, while the amphidiscs arise in almost spherical and only laterally compressed silicoblasts. The central filament is rich in water. As to the origin of the silix we know nothing definitely. The activity of the mother-cells appears to be periodic, for it sometimes secretes spiculin, and then again silix. The cell-contents of the silicoblast are soluble and give rise to the central filament; around this silica is deposited, and so the axial cylinder is formed; layers of silica with their membrane succeed one another until the mother-cell is used up. The spongioblasts are cells which differ essentially from the silicoblasts, and in *Spongilla* are often remarkable for their large size; in it and *Desmacidon* they have the same form and position.

The water, which passes by numerous pores into the sponge, first passes into the meshes of the subdermal network, whence it is distributed to numerous fine canaliculi, to pass to the flagellated chambers which are scattered throughout the whole of the parenchyma. Other canaliculi surround them and carry off the water directly to the efferent orifices. *D. Bosci* appears to belong to Vosmaer's third type, for the region of collar-cells opens directly into wide canals, and then again into wider vessels, or cloacal cavities which open to the exterior.

It is possible that the new sponge is bisexual, but the evidence as to the spermatozoa is incomplete. Ova are developed in great numbers and are found in all parts of the tissue; they are rapidly and easily stained, and can also be recognized by their considerable size from the cells among which they lie. The nucleus and nucleolus are well marked, but the finely granular protoplasm is not bounded by any membrane; indeed, they vary in form, and are certainly amoeboid. Their further development is commenced within the sponge; when four blastomeres are formed a follicle becomes developed, which has the form of an extremely fine membranous investment, and is found in all further stages of development observed within the sponge as a closed capsule.

The author concludes with some observations on the systematic characters of the genus *Desmacidon*.

'Challenger' Hexactinellida.\*—Apart from the systematic portion of Prof. F. E. Schulze's monograph on Hexactinellida included in the reports of the 'Challenger' expedition, the results of most value are to be found in the discussion of the general structure of the soft and hard parts, and of the general system of the group. Of the ninety forms collected by the 'Challenger,' fifty-nine were new, and in addition to these nine new species from other sources are described. The geographical and bathymetrical distribution of the Hexactinellida are discussed at length, and furnish valuable results. From the nature of the case, but few histological results were forthcoming. Thus Schulze was unable to demonstrate the collars or flagella of the ciliated chambers, or the contours of the flat epithelial cells. The only chapter in regard to which serious difference of opinion can arise is of course that which deals with the phylogeny. The Hexactinellida are all derived from a common stem. From this the Hyalonematidæ early diverged. The other branch includes the Uncinataria (Dictyonina minus *Mæandrospongiæ*), an offshoot for the Euplectellidæ, Rossellidæ, and Asconematidæ, and the *Mæandrospongiæ*.

\* Reports of the Voyage of H.M.S. 'Challenger,' Zoology, xxi. (1888) 513 pp. (105 pls.).

**Fresh-water Sponges.\***—Dr. A. Wierzejski found near Lemberg in Galicia, what appeared to be a new form of fresh-water sponge, most nearly resembling *Spongilla novæ terræ*, described by Potts from Newfoundland. More accurate examination convinced him, however, that the form in question was a deformed *Meyenia* (*Ephydatia*) *mülleri* Lieberk., and he believes that the same is true of the Newfoundland species. The author makes a detailed comparison of the two forms, showing their close resemblance and the reasons for regarding both as abnormal varieties. He believes that the conditions affecting the abnormal development, especially of the gemmules, are environmental. The various forms of *Euspongilla* are briefly discussed, and according to Wierzejski are all referable to one species. The paper is mainly of systematic interest.

**New Species of Uruguay.†**—Dr. G. J. Hinde gives an account of two new species of this fresh-water sponge—*U. macandrewi* and *U. pygmæa*—from Paraguay, together with notes on *U. coralliodes*. Dr. Hinde shows that Mr. Carter was wrong in thinking that gemmules were not developed in this genus; in one species gemmules have not yet been found, and in another they are scarce. These facts may be correlated with the evident conditions of existence to which they are subjected; their large size results from an uninterrupted growth of several years' duration, so that the specimens must have lived in positions where they were not exposed to those influences of heat, drought, or cold which limit the existence of most fresh-water sponges to a single season. In other words, their conditions of existence must have approximated closely to those of marine forms. The gemmules are only found in the basal layer of the sponge, and it is probable that they are not produced after the first year. *Uruguayia* is probably related to *Meyenia*. Dr. Hinde approves of Dr. Marshall's suggestion that fresh-water sponges are of polyphyletic origin.

#### Protozoa.

**Vesicular Elements of Protoplasm in Protozoa.‡**—M. J. Kunstler remarks that for the last six years he has taught that the protoplasm of certain beings, especially Protozoa, is not the continuous material—sarcode—as some have declared, but that it has a special and constant structure, which, now that his view has become almost classical, he proposes to speak of as areolar and alveolar. This structure is characterized by an intimate mixture of denser and more fluid matter, the former forming the closed alveoli which contain the latter.

In some recent observations on a Foraminifer M. Kunstler observed that, in a young stage, the protoplasm was perforated by fine vacuoles with thick walls and containing a small quantity of fluid; externally it was covered by a delicate pellicle with oblique striæ. In the course of development these small cavities, in the internal region, become altered in appearance; they grow into small vesicles. At the periphery of the body the primitive appearance persists for a longer time, and there thus arises a differentiation between endo- and ectoplasm. We arrive at a stage in which we have not to do with a protoplasmic being merely

\* Verh. K. K. Zool.-Bot. Gesell., xxxiii. (1888) pp. 529-36 (1 pl.).

† Ann. and Mag. Nat. Hist., ii. (1888) pp. 1-12 (1 pl.).

‡ Comptes Rendus, cvi. (1888) pp. 1684-6.

hollowed by vacuoles, but we see distinct, rounded, floating vesicles, with a dense wall and a contained liquid.

As the animal grows the number of vesicles increases at the expense of the ectoplasmic vacuoles, and they end by constituting by far the greater part of the mass of the body, while the importance of the ectoplasm gradually diminishes. There may, indeed, be at last merely a more or less thick sheath formed by the ectoplasm. The vesicular elements do not only increase by the transformation of the primitive areolæ of the protoplasm, for they are often found elongated or constricted in the middle, as though they were about to divide. The degree of disappearance of the ectoplasm varies much in different creatures. In some the whole of the body is transformed, and, when there is no inter-vesicular liquid, the protoplasm is completely formed by a reticulation with polygonal alveoli; in this case all ectoplasm disappears. In other cases only a few vesicles are produced, the liquid is abundant, and the ectoplasm is more or less distinct. The author denies the existence of the plexus which has been described as being present in the ectoplasm of ciliated Infusoria, and regards it as an optical illusion.

**Physiology of Nutrition in Protozoa.\***—Dr. M. Meissner finds that in the Rhizopods which he examined no chemical or optical change could be detected in starch-grains or oil-drops, but that in many cases a digestion of vegetable and animal albumen was observed. Many Infusoria, if deprived of other food, convert the starch they take up into a substance (? dextrin) which stains red when treated with iodine solution, and, later on, becomes dissolved in the body. Oil, however, remains unchanged. Vegetable and animal albumens are easily dissolved by Infusoria, while albumen that has been cooked appears to undergo no change.

The author remarks that in most text-books *Amœbæ* are described as "flowing around" their food; Duncan, Leidy, and Greenwood have described them as drawing in foreign particles with their hinder immobile parts. He has himself observed both kinds of ingestion, and the latter, which is not easy to make out, in *Amœba princeps*. The animal drew in its prey, which was in this particular case a *Bacterium*, by means of its hinder fringe-like protoplasmic processes, while the water taken in at the same time formed the ingestion-vacuole. In the anterior part of the *Amœba*, in which the nucleus was visible, there was no movement forwards of the protoplasm, but a very lively Brownian movement, during this process.

The Rhizopoda used for observation were *Amœba princeps*, *A. radiosa*, *Pelomyxa palustris*, and *Actinophrys sol*. The Infusoria were *Climacostomum virens*, *Vorticella nebulifera*, and *Peranema trichophorum*. The first-named infusorian digested a *Difflugia* in about twenty-five minutes, when the completely unaltered test was found in a vacuole. The unaltered chlorophyll was generally excreted by the Infusoria, and the chitinous carapace of a Rotifer, which had served as food for a *Stentor*, was also seen to be extruded.

**Nature of Contractile Vacuole.†**—Dr. C. de Bruyne is of opinion that the contractile vacuole of Protozoa has no communication with the exterior. He does not regard it as an excretory organ, but thinks it

\* Zeitschr. f. Wiss. Zool., xlvi. (1888) pp. 498-516 (1 pl.).

† Bull. Acad. R. Sci. Belg., lvi (1888) pp. 718-44 (1 pl.).

probable that it has respiratory and circulatory functions, while its contained liquid may possibly be of a nutrient nature. This judgment is chiefly based on the fact that in no case has the author been able to observe a direct communication with the exterior. He regards it as certain that the liquid which is driven out by the vacuole does not quit the protoplasmic body, but is distributed throughout it. A confirmatory fact is to be found in the observation that in the protoplasm droplets appear which fuse to form the first sign of the contractile vacuole. As the droplets leave the vacuole they grow smaller and smaller till they are, at last, invisible.

**Further Observations on Multinuclear Infusoria.\***—Prof. A. Gruber has made some further observations on multinuclear Infusoria. He finds that there are a considerable number of marine Infusoria, holotrichous, and, especially, hypotrichous forms, in which numerous, sometimes hundreds of nuclei are scattered in the plasma. The fact that these bodies show, when dividing, the well-known striated structure, proves that they are really nuclei. When a division is about to take place they fuse into a single mass; but this may again break up before the daughter-individuals have separated, and so in each of these there may be a large number of nuclei.

It is difficult to say what this multinuclear condition means; it is possible that it is an advantage against injuries, for each separate piece would contain at least a nucleus or a paranucleus, and so be capable of regeneration; such pieces are, also, capable of growing up into complete individuals, while non-nucleated pieces do not last long. In support of this supposition it should be noted that these multinuclear Infusoria are all very soft and changeable in form; some also are greatly elongated, and so frequently exposed to injuries. The multinuclear fresh-water Infusoria, *Loxodes rostrum*, is also a fragile organism, and here too the numerous nuclei have perhaps the same significance.

In *Opalina ranarum* the large number of nuclei is connected with the mode of reproduction which, as is well known, consists in a number of rapidly succeeding divisions, or what might be called a breaking up of the body into a number of pieces, each of which has one or more nuclei.

The case of *Holosticha scutellum* shows us that we are not justified in concluding that a substance is absent because we cannot see it at once with the best of our optical instruments. The paranuclei are here so small, owing to repeated division, that they cannot be seen by our eyes. In *Chonia teres* and in *Trachelocerca* the nuclei themselves are so small that they only appear as fine granulations. If the author's idea that the nucleus is the seat of the histogenetic plasma, and the paranucleus that of the idioplasma (germ-plasma) be correct, *Holosticha scutellum* affords us a proof that the latter, although of material nature, may be removed from our perception, in consequence of repeated divisions. This is generally the case in the metazoic cell, although at certain times of cell-life it may be visible to us. In the process of division in *Holosticha* the nuclear mass, which is at first single, becomes broken up into pieces, not in any chance way, but by a succession of nuclear divisions; we must suppose that the same happens to the substance of the paranucleus, recognizing that we have to do with values which are so small that we cannot perceive them with our present means of research. What

\* Ber. Nat. Gesell. Freiburg i. B., iii. (1888) pp. 57-69 (2 pls.).

we do know is that a body which is at one time visible becomes invisible by repeated divisions, but we recognize that it is still present.

The chief multinuclear holotrichous Infusoria are *Holophrya oblonga*, *Lagynus elongatus*, *Choenia teres*, *Trachelocerca phenicopterus*, and *T. minor* (sp. n.); while the hypotrichous are *Holosticha lacazei*, *multinucleata*, *flava*, *scutellum*, *Uroleptus roscovianus*, *zignis*, *Epiclinites auricularis*, *vermis* (sp. n.), and *Gonostomum pediculiforme*.

**Researches on Ciliated Infusoria.\***—M. Fabre-Domergue divides his present memoir on the ciliated Infusoria into a descriptive and a general part. The former is necessary on account of the disorder and confusion which obtains in our knowledge of the holotrichous forms, on which we have not such fine monographs as those of Stein on the other groups. The species dealt with are *Prorodon niveus*, *Cyrtostomum leucas*, *Ophryoglena atra* and *O. flava* of Ehrenberg, *Plagyopyla fusca* of Quennerstedt, *Balantidium elongatum* of Stein, and *Monodinium Balbianii* g. et sp. nov. The last differs from *Didinium nasutum* by having only one anterior circlet of cilia in the adult stage, and two in that of division, and by its smaller size. From *Mesodinium* it differs in the character of its cilia.

In the general part the author commences with an account of the protoplasm; this is made up of two elements which are closely united—a solid reticulated hyaloplasm and a liquid paraplastm. Both these elements are endowed with a very high degree of osmotic power, but they cannot mix with water during life. It is on the hyaloplasm that the density of the protoplasm depends; it is contractile, and is capable of fusing with itself; it is in its mass that true nutrition is effected, and in it that reserve or excreted material is deposited; it is eminently coagulable by acids, heat, &c. When fresh it is soluble in potash, but cannot be attacked by that reagent after it has been coagulated.

The paraplastm corresponds to the sarcode of Dujardin, as he studied it by transudation through the cuticle of *Paramœcia*. Its chemical properties are the same as those of hyaloplasm, but it has no contractility. The ectoplasm is a more or less dense layer of hyaloplasm; in some cases the reticulations of the endoplasm are closely packed, when it is dense and exhibits no cyclosis, which, however, may be seen when the reticulation is loose. The endoplasm sometimes presents a disposition to form a digestive tube without proper walls; the most marked differentiation is met with in *Didinium nasutum* and *Monodinium Balbianii*. The contractile system is exclusively situated in the innermost layer of ectoplasm; it may be localized at one point of the body in the form of a simple vesicle, with or without a differentiated peripheral layer, or it may form a plexus which completely surrounds the body of the Infusoria. The contractile vesicle opens to the exterior by one or several pores, which, in species with a thick ectoplasm, always remain open, and are only closed by a layer of contractile hyaloplasm. This last may be differentiated to give rise to the contractile fibres of *Vorticella*, *Stentor*, or other contractile forms. There seems to be a relation between the muscular differentiation and that of the layer of trichocysts, the one excluding the other. The ectoplasm corresponding to the cortical layer may give rise to a secretion layer, the presence of which is more or less constant, and which may be considered as the homologue of the cuticle.

\* Ann. Sci. Nat., v. (1888) pp. 1-140 (5 pls.).

The second chapter deals with the phenomena of encystation. This may, in a general way, be said to be provoked by modifications of the medium which become unsuitable for the life of the individual. The author is of opinion that desiccation, or the evaporation of water, which is so often invoked as the sole cause of encystation, has not the importance which has been attached to it, for the modifications which are due to putrefaction play an equal if not a greater part than those due to evaporation. The secretion of the membranes of the envelope of the cyst takes place from within outwards, and the density of the membranes diminishes in the same order. Preservation-cysts must be distinguished from division-cysts; the membrane of the former is quite membranous, while that of the latter is more or less mucous, and soluble in potash, or even in water. The membrane of the cyst is permeable to liquids, but has the property of opposing the passage of certain bodies, or, in other words, acts like a dead dialysing membrane. Active life persists in the cyst until the complete elimination of the food-material which it contains. The residue may be rejected between the body and the membrane, or remain in the interior of the protoplasm under the form of refractive masses. The contents of the cyst are rich in reserve-material (glycogen) which gradually diminishes in cysts preserved in water.

Appendicular organs such as cilia, cirri, or hooks are completely absorbed at the time when the latest life-stage is complete; the nucleus preserves its normal form, and, if it is composed of several granules, these only fuse with one another in the preservation-cysts. Cysts which are preserved in air become highly refractive, and, after a diminution in their volume resulting from the loss of water, they preserve the same volume for an indefinite time. Cysts, on the other hand, which are preserved in water, die after a more or less long time.

Revivescence is variable, and is often effected by simple aeration or under the influence of repeated movements of the support on which the cyst is fixed. This is due to the permeable membrane of the cyst allowing the passage of soluble matters which are favourable to the life of the infusorian. The mechanism of revivescence appears to be an absorption of water considerable enough to swell the protoplasm and dilate the membrane. Some Infusoria have no power of secreting a membranous envelope. Bodies that produce an anæsthetic effect on animals that have a nervous system appear, doubtless on account of the rapidity of the osmotic changes, to have a mortal influence on Infusoria. In one case only—that of *Nassula ornata*—was a real anæsthetic influence only; in this species there is a grey spot which is constantly found in the left anterior region, and is, possibly, a sort of localization of the nervous element; this spot takes on a deep brown colour with osmic acid.

The observations which M. Fabre-Domergue has made on the physiology of nutrition lead him to think that the digestion of food is effected by the same chemical process in all the forms examined; they absorb food presented to them in larger quantities than they can consume, for they reject part without utilizing it. In perfect conditions of nutrition (looked at in the largest way) reserve-material is stored up which is used when the conditions become unfavourable to life.

Conjugation of Vorticellidæ.\*—M. E. Maupas states that he has been able to make complete observations on *Vorticella monilata*, almost

\* Comptes Rendus, cvi. (1888) pp. 1607-10.

as complete on *Carchesium polypinum*, *V. nebulifera*, and *V. cucullus*, and to observe some isolated facts in *V. putrina* and *V. microstoma*. In *V. monilata* and others the microgametes are produced by equal and simple binary divisions; in *V. microstoma* the binary divisions are unequal and gemmæform, while in *C. polypinum* they are equal, but are repeated twice or perhaps thrice.

The microgamete is only provided with a single micronucleus; it attaches itself to the macrogamete by fixing itself at first to the stalk, immediately below its point of attachment to the body; it thence ascends to the lower part of the body of the macrogamete, and fuses with it. As soon as it is thus fixed its micronucleus divides by karyomitosis; while this division is being effected, the two gametes coalesce.

The micronuclei, of which one is simple in the macrogamete and double in the microgamete, now grow, and four micronuclear corpuscles are produced in the former and eight in the latter. Till this is done the macrogamete, which has kept its peristome open, has continued to feed; it now contracts itself and closes its peristome hermetically. Water accumulates within and forms a large vacuole, which pushes all the contents of the body of the macrogamete backwards towards the microgamete. The micronuclear corpuscles of the former have till now been at some distance from the microgamete. Three of the micronuclear corpuscles of the latter and seven of the former now become absorbed and disappear; the two that survive increase considerably in size and enter into contact. They have the form of two large longitudinally striated spindles, and as they elongate they divide; of the four micronuclear corpuscles thus formed two are placed in the microgamete, and two in the macrogamete; the two former become absorbed, while the others fuse and form a single nucleus of mixed origin.

Fecundation is now accomplished; the large watery vacuole disappears, and the contents of the microgamete empty themselves slowly into the body of the macrogamete. The cilia of the peristome which disappeared become renewed, the peristome reopens, and the *Vorticella* begins to eat again.

The new mixed nucleus now passes through several stages of division, and gives rise to eight corpuscles. One of these takes on the type of the micronucleus, while the other seven grow considerably. When this growth has reached its maximum, and if the *Vorticellæ* are well fed, the micronucleus divides into two, and the creature undergoes fission, one half having three nuclear bodies, and the other one. After two analogous divisions each piece has only one large nuclear body of discoidal form, which soon takes on the normal band-shape.

The primitive nucleus of the two gametes divides into a number of small spherical corpuscles, each of which persists for a long time, and only disappears during the fissiparous divisions.

It is obvious that this mode of reproduction in the *Vorticellidæ* does not differ essentially from that of other *Ciliata*. Notwithstanding the difference in size and fate the two gametes play an identical sexual part; both possess a hermaphrodite nucleus which has exactly equivalent reproductive properties.

**Structure of Urceolaria.\***—M. Fabre-Domergue has studied the structure of *Urceolaria* both in marine and in fresh-water forms, and

\* Journ. Anat. et Physiol., xxiii. (1888) pp. 214-60 (2 pls.).

also of certain types closely related to this family. His memoir includes a lengthened historical review, a general description of the structure of Urcolariæ, and in the third place special descriptions of the various genera and species examined.

In discussing the general form, the author notes the weakness of the evidence in favour of Bütschli's theory that the forms of *Lienophora* have their origin from Hypotricha, and that the Trichodinæ are directly descended from *Lienophora*. The interesting fixing apparatus is discussed at length. In such a peritrichous type as *Scephydia* the structure is seen at its simplest; it is specialized in varying degrees in the Urcolariæ. The suctorial mechanism is described. A few notes on the minute structure of ectoplasm and endoplasm are communicated.

As to reproduction, the Trichodinidæ multiply by longitudinal division, but this was never observed in the Lienophoridae. In the division of the former the solid covering pieces split up and regenerate like the rest of the body; they are certainly merely ectoplasmic. The processes of division in *Leiotrocha serpularum* and *Anhymenia scorpenæ* were especially observed.

As a general character of the group, the author emphasizes especially the fixing apparatus, and discusses the classificatory value of the direction of the buccal spire, the presence or absence of a striated cupola on the fixing apparatus, the form of the supporting ring, the character of the resting nucleus, &c.

Urcolaria	{ Naked	{ Buccal spire to left, no striated cupola	} .. .. . . . . . <i>Lienophora</i> C.		
			{ Buccal spire to right, a striated cupola	{ supporting ring smooth	{ circle of cilia .. .. . <i>Urcolaria</i> St.
					{ cilia and cirri .. .. . <i>Leiotrocha</i> n. g.
{ circle of cilia .. .. . <i>Anhymenia</i> n. g.					
{ Ciliated body	{ .. .. . . . . .	{ .. .. . . . . .	{ .. .. . . . . .	{ cilia and cirri .. .. . <i>Cyclocyrrha</i> n. g.	
				{ cilia and velum .. .. . <i>Trichodina</i> Ehrb.	
				{ cilia, with atrophied peristome .. .. . } <i>Cyclochæta</i> Jack.	
			} .. .. . . . . . <i>Trichodinopsis</i> C. & L.		

All the known species are parasitic on the surface or in the interior of marine or fresh-water animals. Amphibians, fishes, molluscs, worms, cœlenterates are all infested. The same species may frequent very different hosts; thus *Trichodina pediculus* of the Hydra is the same as that which infests frog tadpoles and the abdominal cavity of newts.

*Euglena*.\*—Herr J. Fankhauser has observed that when *Euglenæ* are treated so as to remove the water, spiral furrows make their appearance on the surface of the body running in the direction of the ciliary movement.

*Cryptomonadineæ*.†—M. P. A. Dangeard states that Ehrenberg places in *Cryptomonadina* the genera *Cryptomonas*, *Ophidomonas*, *Prorocentrum*, *Lagenella*, *Cryptoglana*, and *Trachelomonas*. The author's conclusions are as follows:—(1) That the work of M. Kunstler must be regarded as inaccurate. (2) The development of *Cryptomonas* includes reproduction by longitudinal division, a production of colonies or palmelloid forma-

\* *MT. Naturf. Gesell. Bern*, 1888, p. xxiii.

† *Bull. Soc. Bot. France*, xxxv. (1888) pp. 127-30.

tions, and an encystment providing new colonies. (3) Solid nourishment is not introduced into the interior of the protoplasm. (4) *Chilomonas* *Paramecium* is distinct from *Cryptomonas*.

**Protozoa of Corsica.\***—Prof. P. Gourret and M. P. Roeser report on the fifty-seven Protozoa which they have found in the new port of Bastia. Among the new forms described by them, *Colpodopsis latifrons* g. et sp. n. is a holotrichous Infusorian which has close relations to *Colpoda*, but differs in the absence of the tuft of oral cilia, and by the possession of a posterior tuft of large cilia; as in *Cryptochilum*, the body is compressed laterally. *Cryptochilum fusiforme* sp. n. has no long rigid seta at its hinder extremity, nor has it any longitudinal cuticular striæ. *Aulax paucisetosa* g. et sp. n. has a more or less oval body, provided with four tufts of cilia, two of which are antero-lateral and two postero-dorsal and postero-ventral, there is a caudal seta, and the body is divided by a ventral groove (whence the generic name) into two equal parts. In front of the mouth, which is situated in this groove, there is a triangular vibratile membrane. It seems to be most closely allied to *Lembadion*, with affinities to *Cyclidium* and *Colpidium*.

*Clypeolum* is a new genus of the Peritricha, which does not appear to be closely allied to any known form. The body is conical, with the apex posterior; the dorsal surface is divided by a transverse groove into two unequal parts, of which the posterior is the larger. The ventral surface is moderately convex; the buccal pit describes the half of a spire, occupies the anterior portion of the ventral surface, and is provided with vibratile cilia and a membranella; the dorsal cones are armed with cilia, which serve to fix the animal.

Among the Hypotricha *Chilodon auricula*, *Egyria semilunaris*, *cristata*, *compressa*, *Kerona ciliata*, and *Holosticha coronata* are regarded as new species. *Amphisiella* is a new genus allied to *Amphisia*, but it has only one row of ventral cirri, and the oral pit is completely ventral and not at all anterior in position. *Stylonethes fusiformis* sp. n. has much resemblance to the incompletely known *Oxytricha scutellum*, which Cohn has, there can be little doubt, referred to a wrong genus. *Psilotrix ovalis* g. et sp. n. seems to be most closely allied to *Actinotricha saltans*, but it differs in the form of its mouth.

*Paramonas ovalis* is a new species of Eustomata-monomastiga characterized by its oral excavation, and *Dinomonas medicanella* and *D. acuta* are new Eustomata-dimastiga. The only new Rhizopod is *Amæba monociliata*.

**Biological Studies on Protista.†**—Dr. M. Verworn, in the course of some psychophysiological investigations, has observed the process of test-formation in some of the test-bearing fresh-water Rhizopods. The form selected was *Diffugia urceolata*, and some further observations were made on the marine *Polystomella crispa*.

The author found that, in *Diffugia*, the formation of the test was effected in just the same way as in other fresh-water Rhizopods, with the difference that only foreign bodies were taken up to form the test by certain reflex processes. There was no regeneration of an injured or removed test by the protoplasmic body, though the vital functions were carried on normally. With *Polystomella* the result was very different;

\* Arch. de Biol., viii. (1888) pp. 139-204 (3 pls.).

† Zeitschr. f. Wiss. Zool., xlvi. (1888) pp. 455-70 (1 pl.).

here there was regeneration, if the nucleus was contained in the injured part, but not otherwise. The processes of regeneration were found to be either in the form of a healing of the wound by deposit of carbonate of lime, which was excreted by the surface of the protoplasm, or in the formation of new chambers. There is a similar process of regeneration in *Orbitolites tenuissima* and *O. complanata*, but the formation of new chambers was more frequent than in *Polystomella*.

When we come to ask how it is that there can be such a difference in regenerative processes between a *Difflugia* and an *Orbitolites*, it is obvious that there must be a difference in the shell. This difference appears to lie in its mode of formation. In the former, as in all Monothalamia, the shell appears at the moment of division, and is quite perfect after the separation of the newly-formed individual. There are no further changes—that is to say, there is no growth of the shell. Put in terms of the protoplasm, this means that it has no secretory activity, and it is in consequence of this that there is no regeneration of a shell which has been injured or totally removed.

In the Polythalamia the relations are quite different; their forms almost certainly reproduce themselves by a kind of spore-formation, although this has not yet been directly observed. It is, however, known that young Polythalamia are to be found as unicamerate Protista in the body of the mother. If these develop into complete Polythalamia a new chamber is formed on the primitive one, to which again another new one is attached, and so on. From this it follows that the Polythalamia, so long as they continue to form new chambers, must have the power of secreting tests. A natural consequence of this mode of test-formation in the Polythalamia is the phenomenon that the forms with a relatively small number of chambers, such as *Polystomella*, have much less power of regeneration than forms with an enormous number of chambers, such as *Orbitolites*. The capacity for regeneration in the Polythalamia is, therefore, proportional to their capacity for forming new chambers; the latter, again, marks the extent of development, and the power of regeneration is, therefore, at least continuous with the whole period of development. Dr. Verworn cannot accept the view of Gruber that we ought not to speak of the development of Protozoa, for he sees in the chamber-formation of the Polythalamia a process which is not mere growth, for the chambers do not resemble one another, and the Protist has quite a different appearance when it has only a few chambers from that which it presents when it has many. Regarding the process as representing a true development, he believes that it may be made useful in determining the phylogenetic relations of some forms of tests.

It would be of interest to discover whether the capacity for regeneration diminishes or is lost when new chambers cease to be formed. The influence exerted by the nucleus in the regeneration of the test of *Polystomella* appears to be of especial importance. Among recent observations on the formation of the nucleus are those which bear on its relation to secretion; Korschelt observed in the epithelial cells which secrete the chitinous ovarian rays in the eggs of *Nepa* and *Ranatra* that the nucleus, at the time of secretion, has a peculiar rhizopodial form, and sends out pseudopodia-like processes to the side in which the chitin is secreted. He further convinced himself that all cells which are known to have branched nuclei have a secretory character. As, however,

there have been no direct observations on the share taken by the cell-nucleus in the secretory activity of the cell, it was of great interest to observe such a case in the regenerative processes of the Polythalamia.

**New Rhizopods.\***—Dr. A. Gruber gives an account of new, or as yet imperfectly described, species of Rhizopods found by him in the harbour of Genoa.

(a) *Protomyxa pallida*, n. sp. The protoplasm is colourless; it has a tendency to flow out in thread-like processes, so that the whole is sometimes a perfect network. The substance of the nucleus is distributed in such small particles that, during life, they cannot be distinguished from the other granules contained in the protoplasm.

(b) Various Amœbæ—*Amœba fluida*, *A. globifera*, inclosing yellowish globules, and *A. flavescens*, yellowish in colour, rich in fine granules, unusually fluid, and with many small nuclei of the vesicular type.

(c) *Schultzia diffluens*. The fine skin which seems to cover the whole is in reality only a slight thickening of the outer layer, and pseudopodia may be given off at any point. The nucleus consists of a great many very small granules.

(d) *Lieberkühnia Bütschlii* n. sp. This species differs from others of the genus in being larger and in having only one nucleus. The skin is easily seen. At the anterior end there is an opening through which the main pseudopodia stalk is projected. From it there ramify a great many fine pseudopodia, and the skin becomes covered so that it seems as if pseudopodia were given off from the whole circumference.

(e) *Polymastix sol* Gruber. The nucleus is of the type usual among Flagellates. Fine thread-like processes radiate from the whole circumference and give it the appearance of a Heliozoon, but these processes have a flagellate motion.

**Observations on Parkeria.**†—Mr. H. J. Carter has some observations on the organic and inorganic changes of *Parkeria*, in which he deals with their “transformations” and not with natural structure. There are also some further observations on the nature of the opaque scarlet spherules in Foraminifera.

**Sherborn's Bibliography of the Foraminifera.**‡—Mr. C. D. Sherborn has published a very useful Bibliography of the Foraminifera founded on previously published Bibliographies, but containing a large amount of original work in the way of enlargement and amendment, and with a number of explanatory notes which much increase the value of the book.

\* Ber. Naturf. Gesell. Freiburg i. B., 1888, pp. 33-40.

† Ann. and Mag. Nat. Hist., ii. (1888) pp. 45-55 (1 pl.).

‡ ‘A Bibliography of the Foraminifera Recent and Fossil, from 1565-1888, with notes explanatory of some of the rare and little-known publications,’ vii. and 152 pp. 8vo, London, 1888.



## BOTANY.

## A. GENERAL, including the Anatomy and Physiology of the Phanerogamia.

## a. Anatomy.\*

## (1) Cell-structure and Protoplasm.

Action of basic substances on living Protoplasm.†—Herr T. Bokorny has investigated the action of a number of different basic substances on living protoplasm. In all cases they agree with the action of ammonia in causing granulation both in the protoplasm and in the cell-sap. Experiments were made with the following substances:—potassa, soda, aminic-bases, diamide or hydrazin, hydroxylamin, strychnine, chinine, atropine, veratrine, chinoline, and caffeine.

Forms of Cells.‡—Prof. L. Errera offers a mathematical explanation of the various forms assumed by vegetable cells, from the corresponding phenomena observed in the blowing of soap-bubbles.

Physiology of the Cell.§—Herr G. Klebs has collected his recent observations on various points in the structure of the cell, adding also some fresh ones.

Algae, leaves of mosses, and similar structures, can be preserved in a living condition in solutions which afford a supply of nutriment, to which 0.05 per cent. of normal potassium chromate has been added.

The author describes the artificial fresh formation of the cell-wall after plasmolysis in concentrated solutions of cane-sugar and glycerin. This takes place with *Vaucheria* within an hour, in most other algae after 1 or 2 days. A similar formation of cell-wall after plasmolysis takes place also with some leaves of mosses, and prothallia of ferns, and with leaves of *Elodea canadensis*; but was not observed with desmids or diatoms, or with the tissues of dicotyledonous plants. The formation of the new cell-wall is best exhibited by the use of congo-red. In a 1 per cent. solution of sugar coloured by congo-red, the first formation of the cell-wall could be detected in opened tubes of *Vaucheria*. The author does not agree with de Vries that the parietal utricle has the special faculty of forming cellulose; it belongs, on the contrary, to every part of the protoplasm. It was distinctly seen that the growth of the new cell-wall takes place by apposition. In *Zygnema* also he found no evidence of growth by intussusception.

The growth and division of protoplasts was observed in *Edogonium*, *Cladophora*, and other objects plasmolysed in a concentrated solution of sugar. Growth of the protoplasts and formation of starch may take place in the dark, but apparently not division. Portions of the protoplast which contain no nucleus can assimilate and form starch, but appear to have no power of growing or forming a new cell-wall.

A peculiar degradation of the chlorophyll-bodies was observed in

\* This subdivision contains (1) Cell-structure and Protoplasm; (2) Other Cell-contents (including Secretions); (3) Structure of Tissues; and (4) Structure of Organs.

† Pringsheim's *Jahrb. f. Wiss. Bot.*, xix. (1888) pp. 206-20 (1 pl.).

‡ *Versamml. Deutscher Naturf. u. Aerzte*, Wiesbaden, Sept. 21, 1887. See *Bot. Centralbl.*, xxxiv. (1888) p. 395.

§ *Unters. Bot. Inst. Tübingen*, ii. (1888) pp. 469-568 (2 pls.). See *Bot. Centralbl.*, xxxiv. (1888) p. 228. Cf. this *Journal*, 1887, p. 254.

*Elodea* and *Funaria*, especially in solutions containing potassium chromate; they are finally transformed into small red balls. The tannin-vesicles of the *Zygnemaceæ* may, under certain conditions, be expelled from the cytoplasm; but this is probably only a pathological phenomenon.

**Plasmolysis in Flowering Plants.\***—Herr A. Wieler has repeated on flowering plants (*Phaseolus multiflorus*, *Vicia Faba*, *Helianthus annuus*), the experiments made by Janse on fresh- and salt-water algæ, and with the same result, viz. that after remaining for a long time in plasmolysing media, the plasmolysis disappears. The phenomenon regarded by Janse as exceptional, appears therefore to be of wider distribution; the results obtained by Wieler being in direct opposition to those of De Vries. †

(2) Other Cell-contents (including Secretions).

**Alkaloid and Sugar in Cyclamen.†**—M. G. Michaud finds in the rhizome of the *Cyclamen* a poisonous principle, cyclamine, and in addition, a new sugar, a levogyrous saccharose, to which he gives the name *cyclamose*.

**Laticiferous product of Mimosops and Payena.§**—MM. E. Heckel and F. Schlagdenhauffen state that their attention has been lately turned to the product obtained from *Mimosops* and *Payena*, as it has been suggested that it might be capable of replacing the gutta-percha obtained from *Isonandra gutta*. After giving the analyses of the various products, the authors state in conclusion that the gutta obtained from the *Mimosops* somewhat resembles in composition and properties that obtained from *Isonandra*, but that it would be necessary to mix it in order to make it a useful industrial product, while, on the contrary, that obtained from *Payena* might more properly be classed among the caoutchoucs.

**Formation of Sugars in the Septal Glands of Narcissus.||**—Mr. E. H. Acton states that in the genus *Narcissus* there are three separate glands, one in each septum of the ovary, not united, and simple; they only occupy the upper part of each septum, not extending below the middle of the ovary. The author gives the details of various experiments, and draws the following conclusions as to the nature of the process of secretion of sugars in *Narcissus* and other plants having the kind of nectaries called septal glands:—(1) That the first stage consists in a maximum formation of protoplasm containing a large amount of metaplast, especially in the form of proteid granules, but not of starch-grains, mucilage, or any form of solid carbohydrate. (2) That the sugars are probably derived from the decomposition of this metaplast, and constitute one of the products of the change. That both glucose and saccharose are formed simultaneously. (3) That the excretion of the saccharine liquid into the gland-cavity in the first instance takes place through the cell-walls without any rupture, splitting away of the cells of the epithelium from one another, or mucilaginous degeneration, and must therefore be supposed to result, in the first instance at least, from the direct activity of the protoplasm in the secreting cells.

\* Ber. Deutsch. Bot. Gesell., v. (1887) pp. 375-80.

† See this Journal, 1885, p. 84.

‡ Arch. Sci. Phys. et Nat., xviii. (1887) pp. 198-212.

§ Comptes Rendus, cvi. (1888) pp. 1625-7.

|| Ann. of Bot., ii. (1888) pp. 53-63 (6 figs.).

**Contents of the Cells of the Aril of the Nutmeg.\***—Herr A. Tschirch finds the cells of the aril of *Myristica fragrans* to be characterized by the presence of a large amount of amyloextrin. The grains are from 2 to 10  $\mu$  in size, and are coloured reddish-brown by an aqueous solution of iodine; they do not contain even a nucleus of true starch. They are usually rod-shaped, rarely roundish or disc-shaped, but often curved or coiled; they seldom exhibit distinct stratification.

**Phosphorus and Phosphoric Acid in Plants.†**—MM. Berthelot and G. André give the results of some experiments with *Amaranthus caudatus* and *A. pyramidalis*, protected from rain but freely exposed to the air, which show that the plant absorbs both phosphorus and potassium from the soil in the early stages of its growth, though the amount of both, and especially of phosphorus, increases less rapidly than the weight of the plant. When flowering begins, the absorption of phosphorus practically ceases, but the absorption of potassium continues so long as the plant grows, and the increase in the quantity of this element during flowering is very considerable. The increase in the quantity of nitrogen is almost proportional to the increase in the weight of the plant up to the beginning of inflorescence, although somewhat smaller in the early stages of growth. When the plant flowers, the total quantity of nitrogen increases but little, and therefore the proportion of this element decreases. In a soil containing about 8 grams of potassium acetate per kilo., the plant grew with some difficulty, but those which survived became much larger. They contained nearly twice as much potassium as under normal conditions, but the increase in the amount of phosphorus followed the ordinary law.

From the results detailed in this paper, it follows that manures containing phosphorus and nitrogen are of no value after the plant has begun to flower, but manures containing potassium may be useful throughout the whole period of growth.

### (3) Structure of Tissues.

**Oil-receptacles in the Roots of Compositæ.‡**—Herr R. Tricbel gives the following general results from the examination of a number of species.

The oil-passages are always the result of the tangential division of the protecting-sheath (endoderm). In most cases they always remain in contact with the protecting-sheath; exceptions occur in *Ligularia* and *Telckia*. The cells surrounding the oil-passage contain more protoplasm than the other cells, in proportion to the size of the passage; as the oil-passage increases in size, these cells become shorter by horizontal division. Fully formed oil is never found outside the oil-passage; the protoplasm of the passage-cells appears to take an important part in its formation. Although formed in the protecting-sheath, the walls of the oil-passage are never suberized; even in comparatively large passages the walls are thinner than those of the surrounding cells. When mature the oil is often entirely replaced by protoplasm. They are intercellular spaces with no special wall of their own; they never contain starch. No

\* Ber. Deutsch. Bot. Gesell., vi. (1888) pp. 138-41.

† Comptes Rendus, cvi. (1888) pp. 711-6.

‡ Nova Acta Acad. Cæs. Leop.-Carol. Germ., i. (1887) pp. 1-44 (7 pls.). Cf. this Journal, ante, p. 447.

connection could be traced between the formation of oil and that of inulin.

Besides the oil-passages, there occur in *Inula Helenium*, in the middle of the root, special oil-receptacles bounded on all sides, also of schizogenous origin. In some roots (*Inula Helenium*, *Cirsium oleraceum*, *C. canum*, *Tagetes patula*, *Lappa tomentosa*), a gradual separation takes place sooner or later of the elements of the cortex, often aided by a previous formation of cavities. In *Inula* and *Lappa* this proceeds so far as to attack the oil-passages, and then the protecting-sheath, and even parts which lie beneath it.

**Formation of Periderm.\***—M. H. Douliot points out that, in considering the origin of the periderm, one has five cases to deal with, viz. :—(1) Epidermal periderm ; (2) Exodermal periderm ; (3) Cortical periderm ; (4) Endodermal periderm, and (5) Pericyclic periderm. In the Rosaceæ, where the periderm is pericyclic, it is formed of layers of hard cork, which from the first present on their radial walls foldings analogous to those of the endoderm. The same phenomenon is shown in the Cnotherææ, and in several genera of Myrtaceæ, where the periderm is pericyclic. In the Cnotherææ the periderm is in immediate contact with the endoderm ; it is the same in the Rosaceæ.

**Protecting-wood and Duramen.†**—Herr E. Praël, adopting Frank's designation of "protecting-wood" (Schutzholz) for the brown-coloured wood formed at spots where injury has been inflicted, has examined the relationship in structure between this and ordinary duramen in a large number of different trees. The following are the more important results.

The protecting-wood formed as the result of injury always agrees in structure with the duramen of the same species. The three substances which fill up the vessels of the duramen—gum, resin, and thyllæ—occur also in the protecting-wood, in contradistinction to the alburnum of the same age. The filling up by thyllæ and by gum takes place in the same plant ; larger vessels have a tendency to become filled by thyllæ. The colour of the cell-wall agrees in the alburnum and in the protecting-wood. In some species the formation of thyllæ in the wood takes place at an early period ; the tendency to their formation is increased by age and by injury to the wood. The strong colouring of the duramen is produced by characteristic pigments, which are probably formed within the cell, and infiltrate into the cell-walls when the tension of the cells ceases. The intimate deposition of these in the cell-wall, and possibly also a chemical combination with lignin, are the reason why they cannot be entirely removed from the cell-wall by substances in which they are soluble. Hermetic closing of cut surfaces of the wood prevents or hinders the formation of protecting wood. The "wood-gum" of Thomsen must be regarded as a modification of cellulose.

**Causes which produce Eccentricity of the Pith in Pines.‡**—M. E. Mer states that transverse sections taken from the trunks of trees are far from being always circular, especially towards the base. The pith is often eccentric because the annual rings are not constant in thickness. This is brought about by various causes, among which may be mentioned :—The influence of the slope on which the tree grows, and

\* Morot's Journ. de Bot., ii. (1888) pp. 158-60.

† Pringsheim's Jahrb. f. Wiss. Bot., xix. (1888) pp. 1-81 (1 pl.). Cf. this Journal, *ante*, p. 248.

‡ Comptes Rendus, cvi. (1888) pp. 313-6.

whether the aspect is north, south, east, or west; then there is the effect of other trees which happen to grow in the immediate neighbourhood; and finally the influence of curvature or lesions.

**Influence of Exposure on the Formation of the Annual Rings in the Savin.\***—M. E. Mer gives the details of a number of observations made to determine the influence of exposure on the formation of the annual rings in the savin. The results may be stated in the fact that nutrition had evidently been made much more active on the east side of the trees than on the west. A southern exposure had produced an analogous though less accentuated effect upon the cambium than a westerly one. One of the tables shows the difference in the breadth of the annual rings east and west.

**Mal nero of the Vine.†**—Sig. O. Comes has studied the cause of the "mal nero" or gummosis of the vine, and finds it to be characterized by the presence of brown corpuscles in the amyloferous parenchyma, which, though described by some writers as elements of solid tannin, he regards as produced by gummy degeneration of the starch-bearing cells.

#### (4) Structure of Organs.

**Formation of Lateral Roots in Monocotyledones.‡**—In further instalments of this paper Prof. A. Borzi describes a second type of the lateral roots of Monocotyledons, in which the meristem is composed of only three distinct kinds of initial cells, producing the plerome, the periblem, and the root-cap, the dermatogen being a dependency of the periblem. He describes in detail the structure of the root in *Elegia deusta* and *Scirpus lacustris*. In the former case the pericambium is constituted of a double row of cells, and this type is characteristic of the Cyperaceæ, Gramineæ, and Musaceæ.

In a third type the growing apices of the radicles are made up of two distinct kinds of initial cells; the one are the common origin of the periblem, dermatogen, and root-cap, the other of the plerome. Examples of this type are furnished by *Richardia africana* and by a number of other Aroideæ.

In the fourth type the apex of the cone of growth with the initial cells are the common origin of the plerome, periblem, and dermatogen, and normally also of the root-cap. This may again be divided into two subdivisions:—in the first the root-cap is altogether distinct from the other histogenous elements of the cone of the root. This occurs in *Sparaxis versicolor* and in many other Irideæ. In the second subdivision, of which *Lilium candidum* may be taken as an example, the root-cap is not distinct from the apex of the cone of growth. Here the initial rows of plerome give birth to the periblem, the outer layers of which are converted into the root-cap. The endoderm of the root forms the dermatogen, laterally to the nascent cone of growth, and, in the region of the apex, a thin temporary protecting sheath. In a further stage of development the increase of the growing apex of a radicle takes place by means of initial cells situated at the apex of the plerome-cylinder, which, as long as they renew this cylinder, generate the periblem. The outer central

\* Morot's Journ. de Bot., ii. (1888) pp. 165-70, 184-91.

† Atti R. Ist. d'Incoraggiamento alle Sci. Nat., 1887. See Rev. Mycol., x. (1888) p. 165.

‡ Malpighia, i. (1887) pp. 541-50; ii. (1888) pp. 53-85.

layers of this cylinder are converted into root-cap, the lateral external layers into dermatogen and root-cap.

**Permeability of the Epidermis of Leaves for Gases.\***—M. L. Mangin gives the details of a number of experiments made to determine the permeability of the epidermis for gases. The following are his conclusions:—

(1) That the permeability of the epidermis of aerial leaves is very limited; ordinarily feeble for plants with persistent leaves, it is rather more considerable in plants with deciduous leaves. (2) In leaves in which the upper and lower surfaces are dissimilar, the permeability of the lower epidermis is greater than that of the upper. (3) The permeability of the epidermis of submerged leaves which are destitute of stomata is very great,—five, ten, or even twenty times more than that of aerial leaves. (4) The permeability of cutinized surfaces is notably weakened by the waxy matter which is found in the cuticle of all leaves; this applies to submerged as well as to aerial leaves.

**Influence of the Turgidity of the Epidermal Cells on the Stomata.†**  
—Dr. R. Schaefer contests the theory of Schwendener ‡ that the chief cause of the widening and narrowing of the cleft of the stomata is the changing pressure exercised on them by the varying turgidity of the epidermal cells which adjoin the guard-cells. From observations on a number of plants (*Polygonum*, *Lilium*, *Potamogeton*, *Azolla*, &c.), he comes to the conclusion that the stomatic apparatus is endowed with an independent function, and that this function is rendered possible only by the changes in the turgidity of the guard-cells. It must, however, be admitted that the turgidity of the neighbouring cells of the epidermis prevents the free expansion of the guard-cells. The width of the cleft at any particular time is therefore the resultant of two opposing forces, the stronger of these being the turgidity of the guard-cells, the weaker that of the adjoining epidermal cells. The observations on the stomata of *Azolla* were especially instructive, as here the opening and closing of the cleft takes place in the ordinary way, and must be brought about by internal forces only, as the thickening-bands which occur in other plants in the neighbouring epidermal cells are here wanting. In grasses, also, the case is very similar, the changes in the width of the cleft being obviously due to forces which have their origin in the guard-cells.

**Anatomy of Spines.§**—Under the term spine Herr R. Mittmann includes all structures which end in a sharp point, and which are adapted by their anatomical construction for the protection of the plant, and for the dissemination of the seeds or fruits through the agency of animals. The following are, with some exceptions, the general anatomical characteristics of all spines:—A strong development of the mechanical tissue; its situation near the surface, and increase in strength from the base towards the apex; the strong thickening and lignification of the walls of the cells of which this tissue is composed. A corresponding reduction of the assimilating and conducting tissues. The peculiarity, especially striking in stem-spines, that growth continues longest at the base of the

\* Comptes Rendus, cvi. (1888) pp. 771-4.

† Pringsheim's Jahrb. f. Wiss. Bot., xix. (1888) pp. 178-205 (1 fig.).

‡ See this Journal, 1882, p. 216.

§ 'Beitr. z. Kenntniss d. Anat. d. Pflanzenstacheln,' 43 pp., Berlin, 1888. See Bot. Centralbl., xxxiv. (1888) p. 359.

organ, so that its apex is its oldest part, and the one which first passes over into its permanent condition.

**Propagula of Pinguicula.\***—M. M. Hovelacque describes organs of propagation hitherto unknown in *Pinguicula vulgaris*, in the form of buds or propagula seated in the axil of the lower leaves of the underground stem, which ultimately become detached. Each bud consists of a short axis and four or five leaves. The first internode elongates considerably. The axis of the bud contains at its base only two vascular bundles; higher up they unite, but not so completely but that the two bundles can still be distinguished. The planes of insertion of the roots do not form at the periphery of the vascular cord a layer resembling that which clothes the vascular system of the underground stem. Nothing warrants the hypothesis that the axis of the propagulum is a stem with several confluent central cylinders.

**Flower of Orchideæ.†**—Herr E. Pfitzer commences a series of papers dealing with the details in the structure and development of the flowers of Orchideæ. The present instalment deals with the Cypripedilinae (*Cypripedium*, *Selenipedium*, *Paphiopedilum*), Ophrydinæ (*Orchis Morio*), and Neottiinæ (*Epipactis*, *Cephalanthera*).

**Ovules of Rumex.‡**—From examination of the structure of anomalous flowers of *Rumex scutatus*, Dr. S. Calloni draws conclusions favourable to the hypothesis of Sachs, that the ovule of *Rumex* is an axial structure, and not a production of the carpel. In the anomalous flowers examined it has become modified in a way opposite to that of the ovary. It is the result of a vertical and lateral proliferation of the axis, and becomes changed into a floral organ, i. e. into a pistil. The mode of evolution of the ovule leads to the same conclusion.

**Seeds of Pharbitis triloba.§**—M. K. Hyrano describes in detail the structure of this plant, a native of Japan, and especially of the seeds, from which he obtains a resin identical in composition and in medicinal properties with the convolvulin contained in jalap-root; and suggests that the seeds of the Japanese plant may be introduced into commerce as a purgative. A resin was obtained by dissolving the finely powdered seeds in alcohol, precipitating with acetate of lead, and purifying the filtrate. The resin thus obtained consisted partly of an oil, the remainder being nearly pure convolvulin.

**Structure of Impatiens.||**—Dr. E. Heinrieher describes several peculiarities of structure in different species of *Impatiens* examined by him. Alone among Dicotyledons, with the exception of *Cucurbita*, and in all the species examined, he finds in the embryo four secondary roots formed already in the seed, which develop rapidly on germination and serve to fix the young plant in the soil.

In *I. Balsamina* (*Balsamina hortensis*), *capensis*, and other species, the cells of the embryo, and especially those of the cotyledons, display strong thickenings of their walls; these thickenings serving as reserve food-materials, which are dissolved and used up in germination. The micro-chemical reactions of these thickenings are given in detail, and

\* Comptes Rendus, cvi. (1888) pp. 507-10.

† Pringsheim's Jahrb. f. Wiss. Bot., xix. (1888) pp. 155-77 (2 pls.).

‡ Mém. Soc. Phys. Genève, xxix. (1887) 23 pp. and 3 pls.

§ MT. Med. Facultät K. Japanischen Universität, i. (1888) pp. 201-8 (2 pls.).

|| Flora, lxxi. (1888) pp. 163-75, 179-85 (1 pl.).

the author concludes from them, in the case of *I. Balsamina*, that they are not composed of cellulose, but of a substance probably identical with Schleiden's amyloid. Similar thickenings occur in the embryos of some species of Papilionaceæ, Cæsalpiniciæ, and *Tropæolum*. During germination large quantities of starch are formed, and the author states that this is not the direct result of assimilation, but of the transformation of the substance of these thickenings. This is shown by the fact that starch is formed in just the same way when the germination takes place in the dark. The object of these thickenings appears to be to protect the seeds from injury by mechanical pressure, and also to a certain extent against being devoured by birds and other animals.

**Anatomy of *Nelumbium*.**\*—Dr. E. Dennert publishes a monograph of *Nelumbium speciosum*, completed from an unpublished MS. of Dr. A. Wigand. The following points are treated of in detail:—The structure of the seedling; the arrangement and imbrication of the leaves; the morphology of the leaf; the structure of the flower; the structure and form of the ripe fruit; the mode of growth of the rhizome; the development of the leaves and flowers; the development of the ovule; the anatomy of the rhizome and stem; the structure and development of the vascular bundles; the structure and formation of the air-passages; the anatomy of the leaf and leaf-stalk; the anatomy of the receptacle and floral organs; the formation of the starch in the leaves and rhizome.

The vascular bundles of *Nelumbium* agree with those of Monocotyledons in their isolated position, and in the absence of cambium; but differ in the fact that the xylem and phloëm do not coalesce, but remain distinct; only in some small bundles were they found united into a closed ring. The large air-passages of the internodes are separated from one another by the pith of the nodes; only in the periphery, where they unite into a white, spongy, structureless mass, are they in communication from one internode to another. The air-passages of the nodes contain unstalked clusters of crystals. The larger part of the leaf is occupied by large air-passages; they are in immediate contact with the epidermis of the under surface, which is entirely destitute of stomata; the single layer of cells of which the lower epidermis is composed is united with the spongy parenchyma above the air-passages by strings composed of a single row of cells; attached to the spongy parenchyma are clusters of crystals projecting into the air-passages. Between the spongy parenchyma and the upper epidermis is a layer of palisade-cells. The upper epidermis consists of a single layer of thick-walled cells, penetrated by numerous stomata. It is elevated here and there into warts consisting of several layers of cells.

### β. Physiology.†

#### (1) Reproduction and Germination.

**Formation of Endosperm in Dicotyledons.**‡—Dr. F. Hegelmaier has investigated with especial care the cases where the endosperm is formed in Dicotyledons by free cell-formation. The filling up of the entire

\* Uhlworm u. Haenlein's Biblioth. Bot., 1888, Heft 11, 68 pp. and 6 pls.

† This subdivision contains (1) Reproduction and Germination; (2) Nutrition and Growth (including Movements of Fluids); (3) Irritability; and (4) Chemical Changes (including Respiration and Fermentation).

‡ Nova Acta Acad. Cæs. Leop.-Carol. Germ., xxix. (1887) pp. 1-103 (5 pls.). Cf. this Journal, 1887, p. 116.

cavity of the embryo-sac with tissue may take place in three different ways, viz.:—(1) The endogenous type, by the division of a nucleated mass of protoplasm which fills up the cavity, as in *Eranthis*; (2) By the formation of tissues, which commences at the periphery on all sides, and advances centripetally; this occurs in other Ranunculaceæ, as *Helleborus*, *Nigella*, *Ranunculus*, *Adonis*, and *Caltha*, in the Rosaceæ (*Cotoneaster*), Umbelliferæ (*Archangelica*), Malvaceæ (*Malva*, *Hibiscus*), certain Leguminosæ (*Hippocrepis*, *Coronilla*, *Anthyllis*, *Lotus*), and some Papaveraceæ (*Glaucium*, *Chelidonium*, *Hypecoum*, *Eschscholtzia*, *Fumaria*), also, in a modified way, in *Boceonia*, *Scabiosa*, and *Euphorbia*; (3) A formation of tissue commencing at the periphery on one side only, at the micropylar end, and leaving the chalazal part at first more or less unaffected, but afterwards advancing towards it; this was observed in many Leguminosæ (*Cytisus*, *Sarothamnus*, *Baptisia*, *Hedysarum*, *Onobrychis*, *Trigonella*, *Galega*, *Colutea* (?)), and in Polygonaceæ (*Fagopyrum*, *Polygonum*, *Rumex*).

In the third case the formation of parenchyma from the micropylar end may be so sparing as not entirely to envelope the embryo, as in the Caryophyllaceæ; or the enveloping tissue may be broken through and ruptured before it reaches the hinder part of the embryo-sac, as in Chenopodiaceæ, Nyctagineæ, *Phytolacca*, and some Leguminosæ. A peculiar modification of this process occurs in those cases where it is localized to some other part of the embryo-sac than its apex, namely, in a concavity, as in strongly campylotropous ovules; this is characteristic of the majority of species of *Lupinus*. *Tropæolum* is peculiar in the parietal layer of protoplasm not breaking up into cells.

These various modes of formation of endosperm only correspond to a certain extent to systematic affinities; thus *Eranthis* differs from the other Helleboreæ, and the Leguminosæ are broken up into several groups. Free cell-formation, in the narrowest sense of the term, has not at present been observed; the ordinary process being an intermediate one between that and true cell-division.

The author points out various essential differences between the process of the formation of the endosperm in Dicotyledons and that of the primary and secondary prothallium in the heterosporous Vascular Cryptogams, such as *Selaginella*. In Marsiliaceæ and Salviniaceæ, and in the formation of the primary prothallium in *Selaginella*, a true process of cell-division takes place. The prothallium of Coniferæ, in which there is not the sharp differentiation into two distinct portions which occurs in *Selaginella*, is at first formed by free cell-formation round distinct nuclei; though cell-division afterwards takes place in the formation of the tissue.

The endosperm-tissue has two distinct functions, separated from one another in time by a period of rest. In the first place it serves as a reservoir for the reserve-substances subsequently consumed by the embryo; and in the second place it conveys nutrient materials to the embryo on its free surface during the period of its development. In some cases, however, this latter function is performed vicariously by the fluid of the embryo-sac, or a portion of the material is conveyed by the enlarged base of the embryo, whether developed into a suspensor or not; but in these cases the endosperm always co-operates in the conveyance of the nutrient material.

**Fertilization of Euphrasia.\***—Herr A. K. v. Marilaun discusses the modes of fertilization in species of *Euphrasia*—*E. rostkoviana*, *E. minima*, *E. Odontites*, *E. lutea*. In reference to the first of these species, the flowers are protogynous; in the first stage the style protrudes for some distance beyond the anthers, and self-fertilization is impossible; after twenty-four hours an intercalary growth occurs in the corolla, by which the tube is lengthened, the stamens pushed forward, and the style straightened. In this second stage the stigma now lies on the anthers of the anterior stamens, but cannot sink deeper because of the long hairs binding the two anthers together. Meanwhile the anthers have opened, but the pollen is not allowed to escape until an insect visiting the nectary shoves apart the obstructing anthers and dusts itself with pollen. When the animal withdraws, it cannot touch the stigma, but takes its load to a stigma in the first stage. In the next stage a growth again takes place in the lower portion of the corolla, the stamens are again shoved forward, the stigma lies above the two posterior anthers. These are not felted together by hairs, they are pressed apart by the style, the stigma passes into the pollen-filled space between the anthers, and in this stage self-fertilization may occur.

The slightly different conditions in the other three species are then described, and the author notes how the differences form not only specific distinctions, but generic characters. Thus *Euphrasia Odontites* is nearer to *Bartsia* than to the white-flowered species of *Euphrasia*; while *E. lutea* strikingly suggests *Tozzia*. In establishing the genera more emphasis should be laid upon the reproductive than upon the floral organs.

**Adaptation of the Flowers of Eremurus altaicus to Cross-fertilization.†**—Herr U. Dammer describes the arrangements in this flower for hindering self-pollination and promoting cross-fertilization. He considers the chief agents in pollination to be *Syrphus pyrastris* and other Syrphidæ, and not, as H. Müller states, night-flying moths.

**Germination of Monocotyledons.‡**—Herr M. Lewin has studied the development of the seedling in a large number of Monocotyledons belonging to the orders Alismaceæ, Liliaceæ, Iridææ, Commelynaceæ, Scitamineæ, Aroideæ, Palmæ, and Gramineæ. In Monocotyledons the first leaves which develop have often special characters. One of the species specially studied is *Tamus communis*. Almost at the commencement of germination the tubercle begins to develop at the base of the cotyledon, in the region corresponding to the tigellum; from different points of the small spherical tubercle thus formed grow adventitious roots, which increase rapidly in number. Other interesting details are given in the cases of other plants.

**Chemistry of Germination.§**—Dr. A. Menozzi publishes a preliminary account of his chemical researches on the germination of *Phaseolus vulgaris*. His object was to study the transformations of nitrogenous and non-nitrogenous substances in germination. As far as he could observe, the most abundant product was asparagin, then amidovalerianic acid, then phenyl-amido-propionic acid. A substance like leucine

\* Verh. K. K. Zool.-Bot. Gesell., xxxviii. (1888) pp. 562-6 (1 pl.).

† Flora, lxxi. (1888) pp. 185-8 (1 fig.).

‡ 'Bidr. t. Kjertbladets anat. hos Monocotyledonerna,' Stockholm, 1887. See Bull. Soc. Bot. France, xxxv. (1888), Rev. Bibl., p. 77.

§ Arch. Ital. Biol., ix. (1888) pp. 235-42.

was also obtained, beside hypoxanthin and xanthin. That the substances obtained result from the transformation of reserve products in the seeds, is of course shown by the fact that before germination there was no asparagin nor any of the substances afterwards present. The author meanwhile abstains from general conclusions.

(2) Nutrition and Growth (including Movements of Fluids).

**Assimilation and Expiration of Plants.\***—Herr U. Kreusler describes experiments instituted to ascertain the influence of lower temperature on the assimilation of plants.

The plants observed were the bramble, bean, castor-oil, and cherry-laurel; the conditions of experiment and the methods employed were the same as on former occasions, but the temperatures were lower. At zero the exhalation of carbonic anhydride was 17–20 per cent. of that which occurs at 20° C. in the case of the cherry-laurel and castor-oil plant; in the case of the bramble, the exhalation was only one-half of that at 10°. Assimilation at zero is for the cherry-laurel only 8 per cent. of the possible maximum.

**Production of Vegetative from Fertile Shoots of *Opuntia*.†**—Herr F. Hildebrand describes in detail experiments in causing fruits of *Opuntia* to vegetate by detaching them and placing them in contact with the soil. The species experimented on were *O. Ficus-indica*, *O. Rafinesquina*, and an unnamed cultivated species. In all cases the tendency was for cultivation of this kind to produce vegetative rather than fertile shoots. In some cases fertile shoots were first produced, but the tendency to the production of vegetative shoots gradually gained the upper hand. The tendency to produce both fertile and vegetative shoots can, however, be incited in almost any part of the plant by external influences.

**Viviparous Plants and Apogamy.‡**—Herr E. H. Hunger describes the appearance of viviparous buds in *Poa bulbosa* and *alpina*, *Polygonum viviparum*, *Atherurus ternatus*, *Ficaria*, and *Fourcroya*. In *Poa bulbosa* he thinks we have a true instance of apogamy combined with viviparousness, and to a less extent in *P. alpina*, *Polygonum viviparum*, and *Fourcroya*, but not in *Atherurus ternatus* or *Ficaria ranunculoides*. In *Poa bulbosa* the bulbs are formed in the fructification, but not in connection with the flowers, which are usually altogether wanting, or, if present, unfruitful; they consist of two or three leaves strongly thickened at the base. Where seeds are produced, the resulting seedlings show no special hereditary tendency to the formation of bulbs. The bulbs borne in the inflorescence also usually produced, on germination, normal plants with no well-marked tendency in this direction; while, on the other hand, the terrestrial buds displayed the inherited tendency very strongly.

**Conduction of Sap through the Secondary Wood.§**—Herr A. Wieler has investigated, in the case of a number of different dicotyledonous trees,

\* Bied. Centr., 1888, pp. 265–7. See Journ. Chem. Soc. Lond., Abstracts, 1888, p. 742.

† Ber. Deutsch. Bot. Gesell., vi. (1888) pp. 109–12 (1 pl.).

‡ 'Ueb. einige vivipare Pflanzen u. d. Erscheinung d. Apogamie b. derselben,' 63 pp., Bautzen, 1887. See Bot. Ztg., xlv. (1888) p. 332.

§ Pringsheim's Jahrb. f. Wiss. Bot., xix. (1888) pp. 82–137 (1 pl.).

the part played by the secondary wood in the conduction of sap, and the importance of the anastomosing of the veins in the leaves for the supply of water to the transpiring surfaces.

In all the trees examined, with possibly the exception of the horse-chestnut, only a portion of the alburnum of the branches has the power of conduction, and even this portion displays the property in very different degrees, the last annual ring exhibiting it the most strongly. The method of examination was by causing the wood to absorb a soluble pigment, and the same results were obtained with fuchsin and with methylene-blue. The different vessels in the same vascular bundle display very different properties in this respect. The author confirms Pfeffer's statement that many soluble aniline-pigments pass readily through the protoplasm.

**Development of Wheat.\***—M. Balland states that an ear of corn rapidly increases in weight and attains its maximum about the thirtieth day after flowering; it then diminishes progressively during the fifteen days which precede harvest. The grain follows the same course, but it attains its maximum a few days later. Inversely the other parts of the ear (the rachis and chaff) diminish up to the moment when the grain attains its maximum; they are then to the grains nearly in the proportion of one to four. While the grain grows, the acidity of the nutrient fluids diminishes, and we are able to follow the condensation of the soluble alluminoid matter simultaneously with the transformation of the sugar into starch.

**Root-pressure.†**—Mr. C. B. Clarke represents the accepted doctrine regarding root-pressure thus:—"Another kind of motion of water in the plant, depending not on suction but on pressure from below, is caused by the roots. It is the root-pressure which forces out drops at particular points of the leaves." The author denies that root-pressure exists in any case, and maintains that the whole mechanical fluid action in plants must be considered in accordance with the laws of capillarity.

**Curvature of Plants.‡**—M. F. Elving states that it is well known that plants grow in a certain direction, and that this direction is determined by their weight, by radiation, humidity, &c., and that they seek to regain their normal position by characteristic curvatures if they are in any way disturbed. If a tube containing *Phycomyces nitens* is placed horizontally, the first effect noticeable is a movement of the protoplasm towards the uppermost wall of the cell; in consequence of this, growth takes place to a greater extent in the upper part. It may be taken as a general rule, then, that flexion of a stem favours the development of the collenchyma on the convex side, while hindering it on the other side.

**Influence of certain Rays of the Solar Spectrum on Root-absorption and on the Growth of Plants.§**—Mr. A. B. Griffiths and Mrs. Griffiths daily exposed mustard and bean plants grown in calcareous soil, to which had been added a definite amount of ferrous sulphate, to various portions of the solar spectrum. Incineration of the plants showed that the greatest amount of ferric oxide was contained in those exposed to the

\* Comptes Rendus, cvi. (1888) pp. 1610-2.

† Journ. of Bot., xxvi. (1888) pp. 201-3.

‡ Morot's Journ. de Bot., ii. (1888) pp. 197-200.

§ Proc. Roy. Soc. Edin., cxxiii. (1887) pp. 125-9.

yellow-green rays D-E, under the influence of which rays also the greatest amount of oxygen is evolved. Examination of the plant for sulphur as representing the albuminoids, which must have derived their sulphur from the ferrous sulphate, showed that the maximum of albuminoids was attained under the influence of the rays D-E.

**Absorption of Nitrogen by Plants.\***—Herren Helriegel and Willfarth have made some experiments in boxes in which were sown oats, peas, buckwheat, &c. It was found that those of the order Papilionaceæ were able to grow and flourish long after all the nitrogen present in the soil had been absorbed by them, whereas oats, &c., only grew as long as there was any of the nitrogen left that had been originally contained in the seed, &c.

### (3) Irritability.

**Method of Studying Geotropism.†**—Miss A. Bateson and Mr. F. Darwin describe a method for studying geotropic curvatures. If a flower-stalk remains for an hour or two pinned down to a board in a horizontal position, so that no curvature can take place, a well-known result is seen on its being released. The freed ends spring up with a sudden geotropic curvature. The method employed by the authors is based upon this fact. Geotropic stems were immovably fixed at various angles, and the amounts of curvature occurring on release were taken as representing the geotropic stimulus corresponding to each position. Whatever may be the faults of the method, it has one merit, that the organ is exposed to a constant instead of to a varying stimulus, as must be the case if the stem is free to curve during the period of stimulation. The authors then give the results of a series of experiments made with the young flower-stalks of plantain (*Plantago lanceolata*).

**Chemotactic Movements of Bacteria, Flagellata, and Volvocineæ.**—Dr. W. Pfeffer in a previous work has shown that the spermatozoids of ferns and *Selaginella* are attracted by malic acid, and that this serves to conduct them into the archegonial canal. In the present paper ‡ he proves that motile bacteria, colourless Flagellata, and some chlorophyll-containing Volvocineæ are in a similar manner enticed or dispersed by certain substances, a phenomenon which he designates by the term "chemotaxis." The method of investigation is very simple. A capillary tube closed at one end, from 0·03 to 0·08 mm. wide, and 4 to 7 mm. long, is furnished with a definite solution, and its open end pushed into the drop of fluid containing the organisms in a state of equal distribution. To obtain a striking congregation of bacteria for instance, it suffices to introduce a capillary tube charged with a 2 to 4 per cent. meat solution in a drop containing *B. termo*. In a few seconds there is already a marked confluence of the bacteria, and in from 1 to 2 minutes the anterior part of the tube is thickly filled with them.

The author worked out completely the chemotaxis of *Bacterium termo*, *Spirillum undula*, and *Bodo saltans*; *Bacillus subtilis*, *Spirillum rubrum*,

\* Bied. Centr., 1888, pp. 228-30. See Journ. Chem. Soc. Lond., Abstracts, 1888, p. 742.

† Ann. of Bot., ii. (1888) 65-8.

‡ Untersuch. Bot. Inst. Tübingen, ii. (1888) p. 582. Cf. this Journal, 1884, p. 412.

typhoid bacillus, *Spirillum cholerae asiaticæ*, &c., were also investigated with positive results. On the other hand, the colourless Flagellate, *Astasia proteus* and *Chilomonas paramecium* were found to be absolutely non-chemotactic, as also were the green Flagellata and all the Infusoria investigated (12); the latter indeed seemed to possess no chemotactic susceptibility whatever, oxygen excepted.

The organisms examined were found to be positively or negatively chemotactic according to the nature of the stimulant material, and sensitive in different degrees. A given substance may act upon one organism, but not upon another, e.g. dextrin excites *B. termo* to an extraordinary degree, but not *Spirillum*.

Among inorganic bodies the salts of potassium in general, and among the organic bodies peptones particularly act as lures, the carbohydrates less, whilst glycerin has no effect.

Negative chemotaxis or dispersion of the organisms is usually produced by alcohol, acid and alkaline reactions, and by a too great concentration of the stimulant material. The nutritive value of any substance, and its stimulant capacity, stand in no direct relation; glycerin, for instance, possesses no chemotactic action, although an excellent nutritive material for many bacteria. How extremely sensitive organisms are to certain substances is shown by the fact that *B. termo* is attracted by even a 0.001 per cent. peptone solution.

The paper contains numerous remarks on the convenient application of chemotaxis for catching certain organisms, which if correct may be found of service in shortening the time taken in obtaining pure cultivations.

M. J. Massart\* has repeated, and to a large extent confirmed, Dr. Pfeffer's observations. The Flagellata, *Tetramitus rostratus* and *Chilomonas paramecium*, stated by Pfeffer to be non-chemotactic, he finds, on the other hand, to be very sensitive.

#### (4) Chemical Changes (including Respiration and Fermentation).

Changes of Substance and Force connected with Respiration.†—Dr. H. Rodewald continues his observations on the chemical and mechanical changes which accompany the process of respiration of plants.

The average value of the fraction  $\frac{\text{CO}_2}{\text{O}_2}$  he finds to be 1.061; for 1 cm. of  $\text{CO}_2$  there is given off 4.37 cal., and for 1 cm. of  $\text{O}_2$  4.46 cal.

Formation of Starch from various substances.‡—By immersing filaments of *Spirogyra* in the substances in question, Herr T. Bokorny finds that plants have the power of producing starch from various substances of the nature of alcohols, as well as from glucoses, viz. from methylol (probably in consequence of its splitting up readily into formic aldehyd and methyl alcohol), glycol, glycerin, and mannite. All these substances agree in being compounds of hydroxyl OH with carbon and hydrogen.

\* CR. Soc. R. Bot. Belg., 1888, pp. 88-98.

† Pringsheim's Jahrb. f. Wiss. Bot., xix. (1888) pp. 221-94 (1 pl.). Cf. this Journal, ante, p. 455.

‡ Ber. Deutsch. Bot. Gesell., vi. (1888) pp. 116-20.

## γ. General.

**Relationship between Ants and Plants in the Tropics.\***—Herr A. F. W. Schimper publishes the results of observations on the nature of the connection between myrmecophilous plants and the ants which inhabit them in tropical America.

The leaf-cutting ants are probably the most powerful enemy to which vegetation is subject in tropical and subtropical America. Other species of ants, on the other hand, afford protection to vegetation by destroying or keeping aloof the leaf-cutting ants and other enemies of plants. The orange trees in the province of Canton in China are in this way protected by nests of tree-dwelling ants.

With regard to myrmecophilous trees and shrubs, the author states that in most cases no special adaptation in the structure of the plant to its habitation by ants can be proved. In other cases, however, observed by him in Brazil, it is evident that such adaptations do exist, and this is especially the case with *Cecropia adenopus*. In this and in other species of the genus, the ants inhabit hollow cavities in the tubular internodes, which serve, in the first place, to add to the flexibility of the branches, but also as a dwelling-place for countless myriads of ants. The protective function of these ants is shown by the facts that in every specimen in which these cavities were not inhabited by ants, the leaves were found to be entirely destroyed by leaf-cutting ants. In another species of *Cecropia* which is not inhabited by ants, and which does not possess these cavities, the tree is protected from the visits of the leaf-cutting ants by the extreme smoothness of the stem, which is covered by a coating of wax. In *C. adenopus* a special source of nutriment is furnished to the ants which inhabit it, in a quantity of ovoid or pear-shaped bodies, which cover the under side of the base of the leaf-stalk with a velvety coating. These bodies, known as "Müller's corpuscles," are probably metamorphosed organs for the excretion of mucilage or resin. They are but slightly attached to the hairs, and are very rich in albuminoid substances and in fatty oils. They are entirely wanting in the species of *Cecropia* which are not inhabited by ants. In *Acacia sphaerocephala*, the spines of which are inhabited by ants, similar bodies, which serve for their nourishment, are found at the apex of the pinnae. If these bodies are removed they are formed again with great rapidity.

Extra-floral nectaries are regarded by Schimper, along with Belt and Delpino, as having for their primary function the attraction of friendly ants which protect the plant from the attacks of leaf-cutting species. The formation of the nectar in these nectaries may extend over a period of several weeks. The nectaries are not in themselves directly serviceable to the plant, as can be shown by removing them, when the health and vigour of the plant are not injured. The sugar in the nectar is undoubtedly a product of the assimilating power of the leaf itself. Extra-floral nectaries are especially numerous in the Tropics where the leaf-cutting ants most abound; and they are found most frequently in the floral region, where they are most serviceable in rendering protection to the organs of reproduction.

\* 'Die Wechselbeziehungen zw. Pflanzen u. Ameisen im tropischen Amerika,' 96 pp. and 3 pls., Jena, 1888. See *Naturforscher*, xxi. (1888) pp. 171-4. Cf. this Journal, *ante*, p. 87.

**Deposition of Calcareous Incrustations on Fresh-water Plants.\***—Herr N. Pringsheim maintains that the deposition of a calcareous incrustation on plants growing in fresh water is necessarily connected with the process of assimilation, and takes place only in the light. This can be shown by experimenting on *Chara*, *Nitella*, Confervaceæ, the leaves of some mosses (*Mnium*) or aquatic flowering plants, with a saturated solution of calcium bicarbonate. The lime-salt used is by no means indifferent, no precipitation taking place from neutral calcium carbonate. The deposition is accompanied by the evolution of bubbles of oxygen, and is evidently a function dependent on transpiration.

**Action of Ether on Plant-life.†**—Dr. G. Brenstein finds that an atmosphere saturated with ether kills barley and wheat sprouts within thirty minutes. Five minutes' exposure affected the plants, the tips of the leaves, consequently the oldest portions, being first killed, whilst the basal portions of the leaves, and therefore the youngest parts, resisted longest. Experiments made with portions of *Elodea canadensis* showed that five minutes' exposure to the ether atmosphere sufficed to kill the plant; the thin texture of the leaf of this plant seems to make it more permeable to ether than are the leaves of wheat and barley.

## B. CRYPTOGAMIA.

### Cryptogamia Vascularia.

**Systematic Position of Isoetes.‡**—Dr. S. H. Vines points out the objections to the position now generally assigned to the Isoetæ—that proposed by Sachs and Goebel, according to which they, together with the Selaginellaceæ, make up the class Ligulatæ. He suggests, on the other hand, that they are a heterosporous form—and the only one hitherto recognized as such—of the Eusporangiata Filicinæ. In its general habit, and in the absence of sporangiferous cones and of specially differentiated sporophylls, *Isoetes* resembles Filices, as also in the more general features of its embryogeny. The velum of *Isoetes* may also be homologous with the indusium of many Filices.

**Development of the Root of Equisetum.§**—Mr. J. R. Vaizey has investigated the origin of the double endoderm of the root of *Equisetum*. He finds that the apical cell gives rise to two kinds of tissue, the outer layer or cylinder constituting the exomeristem, which incloses the central cord constituting the endomeristem of Russow. The exomeristem is distinguished from first to last by its cells being arranged in radial rows, while those of the endomeristem are not so arranged, and are smaller than those of the exomeristem.

### Muscineæ.

**Reproduction of Thamnium alopecurum.||**—Herr J. B. Schnetzler describes specimens of *Thamnium alopecurum*, which were fructifying freely, and the sporanges filled with well-developed spores. The author placed the moss under water; it continued to grow all the winter, and

\* Pringsheim's Jahrb. f. Wiss. Bot., xix. (1888) pp. 138-54.

† Arch. Pharm., xxv. pp. 918-24. Cf. Journ. Chem. Soc. Lond., 1888, Abstr., p. 624.

‡ Ann. of Bot., ii. (1888) pp. 117-23.

§ Bull. Soc. Vaud. Sci. Nat., xxiii. (1888) pp. 161-4.

§ Ibid., pp. 123-4.

in the spring formed a number of new shoots. After growing under water the moss exactly resembled a sub-lacustrine variety of *T. alopecurum*, which grows at a depth of 200 metres in the Lake of Geneva. On examining the young shoots, brown filaments which were formed of cells with oblique septa were seen. On these filaments or rhizoids gemmæ were developed.

**Protonema of *Schistostega osmundacea*.**\*—Herr F. Noll describes the mode of vegetative reproduction of the protonema of this moss, and explains its shining appearance by its peculiar construction, which causes its lenticular cells to concentrate all the light that falls upon them on their posterior wall, and to illuminate intensely the chlorophyll-grains which collect on these walls. The rays which enter these cells in a parallel direction are so reflected that they again emerge parallel or slightly convergent, by which the bright shining appearance is brought about.

**Physiological and Comparative Anatomy of Sphagnaceæ.**†—In this treatise Herr E. Russow treats especially of the anatomy of the leaves of *Sphagnum* from a physiological point of view. He shows that not only the leaves on both the erect and the pendent branches, but also the separate parts of the leaf, are adapted, by their structure, to the various requirements as regards firmness. This firmness is chiefly secured by the stiffening of the hyaline cells by means of annular and spiral fibres. These occur in all the cells of the leaves of the pendent branches, and in those of the basal half of the cells of the erect branches, in the form of bands projecting slightly into the cell-cavity. In the cells of the upper half of the leaves on the erect branches there are, on the other hand, a larger or smaller number of broad stiffening plates or bands placed at right angles to the cell-wall. The diameter of these plates at right angles to the cell-wall decreases from the apex towards the base of the leaf. It is chiefly by these plates that the surface of the leaf becomes folded in; they run across the leaf, and are united by anastomoses running in the direction of the length of the leaf. The leaves belonging to the fertile stem and branches, which are usually completely concealed, have no similar stiffening-bands; they consist simply of uniform chlorophyllous cells, their main function being the nutrition of the sporogonium. The pseudo-fibres of the stem-leaves must be distinguished from the true fibres of the hyaline cells, being nothing more than portions of cell-wall which remain behind between the orifices resulting from resorption. The pores of the hyaline cells have, in all the species which do not permanently live in water, their margins strongly thickened in a peculiar way, for the purpose of preventing the rupture of the margins, and in order to facilitate the absorption and the retention of water. The stiffening-bands increase the inner surface of the hyaline cells, and hence their capillary power. The position of the chlorophyll-cells is determined by the necessity of protection from light. Either on both sides or on the one most exposed to the light they are partially or entirely covered on both sides by the hyaline cells. When this is not the case, the free walls of the chlorophyll-cells are imbricately apicu-

\* Versamml. Deutscher Naturf. u. Aerzte, Wiesbaden, Sept. 21, 1887. See Bot. Centrbl., xxxiv. (1888) p. 399.

† 'Zur Anat. resp. physiolog. u. vergleich. Anat. d. Torfmoose,' 35 pp. and 5 pls., Dorpat, 1887. See Bot. Ztg., xlvi. (1888) p. 335.

late, and the light can reach them only after being repeatedly refracted in the cells. In the pendent branches, where the leaves are better protected from light, the two kinds of cell lie side by side without covering one another, but the hyaline cells are more tumid. Further protection from the light is afforded by papillæ, and the deposition of pigment in the cell-walls, giving the living plant a brown appearance, especially in sunny spots.

The use of these morphological characters for purposes of classification is then discussed.

**Forms of Sphagnum.\***—Dr. Röhl defends his previously published views against the objections of Warnstorf, and adduces additional arguments in favour of classifying the numberless forms of bog-mosses into a number of series passing into one another by insensible gradations, rather than into sharply differentiated species and varieties.

### Algæ.

**Classification of Chlorophyceæ.†**—Dr. J. B. de Toni proposes the following classification of the green algæ, viz. :—

#### Order I. CONFEROIDEÆ.

Suborder 1. *Oogamæ*. Families :—Colochætaceæ, Mycoideaceæ, CEdogoniaceæ, Sphæropleaceæ, Cylindrocapsaceæ.

Suborder 2. *Isogamæ*. Families :—Ulviceæ, Chætophoraceæ, Ulothricaceæ, Cladophoraceæ, Pithophoraceæ, Phæothamnaceæ, Trentepohliaceæ.

#### Order II. SIPHONÆ.

Suborder 1. *Oogamæ*. Family :—Vaucheriaceæ.

Suborder 2. *Anogamæ*. Families :—Botrydiaceæ, Phyllosiphonaceæ, Bryopsidaceæ, Derbesiaceæ, Spongodiaceæ, Udoteaceæ, Valoniaceæ, Caulerpaceæ, Dasycladaceæ.

#### Order III. PROTOCOCCIDEÆ.

1st Family. *Volvocaceæ*. Subfamilies :—Volvoceæ (Oogameæ, Isogameæ), Hæmatococceæ, Cylindromonadeæ.

2nd Family. *Palmellaceæ*. Subfamilies :—Cænobieæ (Hydrodictyeæ, Pediastreæ, Scenedesmeæ), Pseudo-cænobieæ, Eremobieæ (Raphidieæ, Characieæ, Endosphærieæ), Tetrasporeæ, Dictyosphærieæ, Nephrocytieæ, Palmelleæ.

#### Order IV. DESMIDIOIDEÆ.

1st Family. *Desmidiaceæ*. Subfamilies :—Eudesmidieæ, Didymoideæ (Closterieæ, Docidieæ, Micrasterieæ).

2nd Family. *Zygnemaceæ*. Subfamilies :—Mesocarpeæ, Zygnemeæ.

**Classification of Confervoideæ.‡**—Prof. A. Hansgirg points out that two quite different genera of algæ have been confounded under the name *Aphanochæte*, viz. :—(1) the true *Aphanochæte* Berth., distinguished by its vegetative cells being furnished with stiff bristles, which appears to be nearly allied to *Coleochæte*, but differing in having no oogamous mode of reproduction, and in its zoogonidia being provided with four vibratile cilia instead of two ; and (2) *Aphanochæte* A. Br. = *Herposteiron* Näg., belonging to the Chætophoraceæ.

\* Bot. Centralbl., xxxiv. (1888) pp. 310-4, 338-42, 374-7, 385-9. Cf. this Journal, 1886, p. 108.

† Notarisia, iii. (1888) pp. 447-53.

‡ Flora, lxxi. (1888) pp. 211-23.

Dr. Hansgirg proposes the following classification of the Confervoideæ or Nematophyceæ:—

A. Vegetative cells uninucleated.

1. COLEOCHÆTACEÆ.

- a. Anoogamæ:—*Aphanochæte* Berth., *Chætopenlis* Berth.; doubtful, *Ochlochæte* Thw., *Aerochæte* Prings., *Phæophila* Hauck, *Bolbocoleon* Prings.  
b. Oogamæ:—*Coleochæte* Bréb.

2. EDOGONIACEÆ.

*Edogonium* Link, *Bulbochæte* Ag.

3. CYLINDROCAPSACEÆ.

*Cylindrocapsa* Reinsch.

4. TRETEPOHLLIACEÆ.

- a. Chroolepidaceæ:—*Trentepohlia* Mart., *Leptosira* Bzi., *Trichophilus* Web., *Ctenocladus* Bzi., *Microthamnion* Ktz., *Chlorotylum* Ktz., *Pilinia* Ktz., *Aeroblaste* Reinsch, *Chlorothamnion* Bzi.; doubtful, *Bulbotrichia* Ktz.  
b. Mycoïdaceæ:—*Phycopeltis* Mill., *Mycoïdea* Cunn.

5. ULOTHRIACEÆ.

- a. Ulothricheæ:—*Hormidium* Ktz., *Schizogonium* Ktz., *Hormiseia* Aresch., *Ulothrix* Ktz., *Glaetila* Ktz. ex p.  
b. Chætophoraceæ:—*Stigeoclonium* Ktz., *Endoclonium* Szym., *Entocladia* Reinke, *Chætophora* Schr., *Draparnaldia* Ag., *Chætonea* Now., *Herpoteiron* Näg., *Reinkia* Bzi., *Chloroclonium* Bzi., *Lithobryon* Rupr.  
c. Ulvaceæ:—*Ulva* L., *Monostroma* Thr., *Enteromorpha* Link., *Zetterstedtia* Ag., *Ilea* Ag., *Diplonema* Kjell., *Schizomeris* Ktz., *Protoderma* Ktz., *Dermatophyton* Pet., *Ulvella* Cronan, *Prasiola* Ag.

B. Vegetative cells 2-multinucleated.

6. CONFERVACEÆ.

- a. Confervæ:—*Conferva* L., *Microspora* Thr., *Chætomorpha* Ktz., *Binuclearia* Wittr., *Rhizoclonium* Ktz.; doubtful, *Confervites* Brougn., *Dictyothele* Bzi., *Urospora* Aresch.  
b. Cladophoraceæ:—*Cladophora* Ktz., *Chloropteris* Mont., *Periphlegmatium* Ktz., *Gongrosira* Ktz. ex p.  
c. Pithophoraceæ:—*Pithophora* Wittr.

C. Vegetative cells multinucleated.

7. SPHÆROPLEACEÆ.

*Sphæroplea* Ag.

New Genera of Perforating Algæ.\*—MM. E. Bornet and C. Flahault refer to the two algæ described by Lagerheim † as perforating the shells of molluscs, viz. *Codiolum polyrhizum* and *Mastigocoleus testarum*. They point out that the so-called chroococcoid cells of the latter alga do not belong to it at all, but to an altogether distinct species, which they now describe as the type of a new genus under the name *Hyella cæspitosa*.

The genus *Hyella* is regarded by the authors as the highest type yet known of the order Chamæisiphonaceæ. It forms, when young, circular patches of an olive colour composed of radiating filaments permeating

\* Morot's Journ. de Bot., ii. (1888) pp. 161–5.

† See this Journal, 1886, p. 665, 1887, p. 285.

the chitinous coat of the shell, and striking branches downwards into the test. Each filament is composed of a number of cells which readily separate from one another, and which may divide internally into secondary cells, and then present a remarkable chroococcoid appearance, the cells thus formed being without doubt organs of propagation. In addition to these *Hyella* produces sporangia resembling those of *Dermocarpa*, usually terminal, pyriform, and containing a large number of minute globular spores.

The organism described by Lagerheim as *Codiolum polyrhizum* is in reality the sporange of an alga most nearly allied to the Siphonocladaceæ, and named by the present writers *Gomontia polyrhiza*. The sporanges, however, differ from any hitherto known. *Gomontia* forms green patches, especially on dead shells, composed of branched segmented filaments. The sporanges result from a total or partial usually unilateral swelling of one of the cells of the horizontal filaments. From these sporanges proceed two kinds of reproductive bodies, biciliated zoospores which conjugate without germination, and aplanospores. These aplanospores do not germinate directly, but give birth to bodies resembling the sporanges from which they spring. After remaining for a time in this form, they put out rhizoids into the shell, or divide into from 2 to 8 secondary aplanospores.

*Ulothrix* and *Stichococcus*.\*—M. E. de Wildeman agrees with Hansgirg in regarding *Ulothrix nitens* Men. and *U. flaccida* Ktz. as forms of the same species, but differs from that authority in his view that *Stichococcus bacillaris* belongs to the cycle of evolution of the same species. *Ulothrix* undoubtedly has a tendency to break up into isolated cells bearing a strong analogy to those of *Stichococcus*, but in their filamentous condition there is always a sufficient difference between them. M. de Wildeman has found, associated with *U. tenerrima* Ktz., another filamentous alga which also has a tendency to break up into isolated cells, and which he identifies with *Glæotila*. He suggests that it is this alga which is really another phase of *Stichococcus*.

*Trentepohlia*.†—M. E. de Wildeman defines the characters of several species of this genus, and confirms the observation that species of *Trentepohlia* enter into the composition of *Cocconium* and of other genera of lichens.

Diatoms from a *Trygon*.‡—Dr. G. B. de Toni has examined the contents of the digestive apparatus of a specimen of *Trygon violacea*, caught in the Adriatic. Besides a few filaments of *Ulothrix implexa* and some fragments of an undetermined *Cladothrix*, he found a large number of diatoms, of which two, *Isthmia enervis* and *Rhabdonema arcuatum*, were additions to the diatom-flora of the Adriatic.

### Fungi.

Luminosity of Fungi.§—Mr. W. Phillips enumerates the following species of fungus as certainly known to be luminous:—*Agaricus olearius* from Europe, *A. igneus*, Amboyna, *A. noctilucens*, Manila, *A. Gardneri*, Brazil, *A. lampas*, Australia, *A. Emerici*, Andaman Isles, *Polyporus*

\* CR. Soc. R. Bot. Belg., 1888, pp. 80-7. Cf. this Journal, *ante*, p. 632.

† CR. Soc. R. Bot. Belg., 1888, pp. 140-8.

‡ Atti R. Istit. Veneto Sci., vi. (1888) 5 pp.

§ Proc. Woolhope Club. See Rev. Mycol., x. (1888) p. 120.

*annosus*, and *P. sulphureus*, Europe, and *Didymium* sp., Jamaica. The luminosity of the following species, all from Europe, rests on more doubtful observations:—*Agaricus fascicularis*, *Corticium cæruleum* and *lacteum*, and *Cladosporium umbrinum*. To these must be added the structures known as *Rhizomorpha*, probably the mycelium of other fungi. The author believes that the seat of the phosphorescence is always the mycelium, and that when the case appears to be otherwise, it is due to a mycelium parasitic on the fungus, and imparting to the latter its luminosity.

**Conidiferous Form of Polyporus biennis.\***—M. Boudier has met with a curious form of *Polyporus biennis* Bull., which may be specified under the name of *Ptychogaster alveolatus*. It was composed of two oblong club-shaped bodies, of from 2½ to 3 cm. in height and 1 cm. in breadth; the pedicels were united in a common stipe some mm. from the base. These club-shaped bodies were of a reddish-white colour, and were tomentose on the surface, which was covered with a slightly prominent network composed of roundish angular or labyrinthiform pores.

**Classification of Basidiomycetes.†**—In the last-published part of his ‘Mycological Observations’ Herr O. Brefeld proposes the primary classification of the Basidiomycetes into two groups, PROTOBASIDIOMYCETES and AUTOBASIDIOMYCETES. In the former the basidia are septated and pluricellular, each cell producing one spore; in the latter the basidia are unicellular, usually giving birth to two or four spores.

The Protobasidiomycetes are again divided into three families, *Pilacreæ*, *Auriculariæ*, and *Tremellinæ*, distinguished by the internal or external position of the basidia and the mode of their septation. In the *Pilacreæ* the basidium is septated transversely, and is composed of four superposed cells, and the fructification is angiocarpous, an envelope being formed round the basidial apparatus, which must perish in order to set the spores free. In the *Auriculariæ* the basidium is also septated transversely, but the fructification is gymnocarpous. The *Tremellinæ* have their basidia septated longitudinally, the primitive mother-cell being divided into four by two septa at right angles to one another; each of the four cells is a long sterigma terminated by a spore.

The Autobasidiomycetes are divided into the following ten families, according to the degree of protection of the fructification:—

Gymnocarpi	{	Dacryomycetes.
	{	Clavariæ.
	{	Thelephoræ.
	{	Tulostomæ (Lycoperdaccæ).
Angiocarpi	{	Hymenogastreæ.
	{	Nidulariæ.
	{	Phalloideæ.
	{	Hydnæ.
Hemi-angiocarpi	{	Agaricinæ.
	{	Polyporeæ.

Comparing this with the ordinary classification, the group usually designated Hymenomycetes includes the last two families of Brefeld’s

\* Soc. Bot. et Mycol. de France, Session Cryptogamique, 1887 (1888) pp. 55-8.

† ‘Unters. aus d. Gesamtgeb. d. Mykologie,’ Heft vii., 178 pp. and 11 pls., Leipzig, 1888. See Morot’s Journ. de Bot., ii. (1888) Rev. Bibl., p. 69.

Protobasidiomycetes, and the angiocarpous and hemi-angiocarpous Autobasidiomycetes. The Tremellini in the ordinary sense of the term include the author's Auriculariæ, Tremellinæ, and the greater part of the Dacryomycetes. The angiocarpous Autobasidiomycetes correspond to the Gasteromycetes.

The Pilacreæ consist of the single genus *Pilacre*. It possesses a peridium composed of the ultimate ramifications of the hyphæ, while the lower parts of the same hyphæ give birth to the basidia. The germinating spore develops into a mycelium, a portion of which grows beneath the surface of the nutrient fluid, while the aerial portion gives birth to conidia. *Pilacre* may be regarded as a Gasteromycete with its basidia septated transversely.

The fructification of the Auriculariæ consists of irregular masses enveloped in abundant mucilage; it is gymnocarpous, the basidia being formed on the surface; each of the four superposed cells of which they are composed puts out a long broad sterigma which traverses the whole of the mucilaginous envelope, and terminates in a large reniform spore. Brefeld divides it into two genera:—*Auricularia*, with which *Hirneola* is united, and a new genus *Tachaphantium*, composed of a single species, which forms small warts on the bark of branches of the lime.

The Tremellinæ have a gymnocarpous fructification, and the basidia are divided longitudinally by two septa at right angles to one another. It comprises the genera *Exidia*, *Ulocolla*, *Craterocolla*, *Sebacina*, *Tremella*, and *Gyrocephalus*. The new genus *Ulocolla* (formed of *Tremella saccharina* and *foliacea*) is distinguished by the mode of germination of the spores, which resembles that of *Exidia*, the spore dividing into two cells, each of which puts out a short filament ending in a group of conidia having the form of straight rods. *Craterocolla* is also a new genus, formed from the single species *Tremella Cerasi*, distinguished by coniferous filaments differing greatly in appearance from those which give birth to the basidia. *Gyrocephalus* is also composed of a single species, *Guepinia helvelloides* Tul.

Of the Autobasidiomycetes the only family treated of in this section of the work is the Dacryomycetes, composed of the genera *Dacryomyces*, *Guepinia*, and *Dacryomitra*, usually placed under Clavariæ, sometimes under Tremellini. The Dacryomycetes are distinguished by their basidia having the form of an elongated bifurcate club, bearing at its extremity two long arms or sterigmata, which narrow gradually upwards, each ending in a single large spore. The characters of the four genera are given by the author in detail.

**New Tubercularia.\***—M. N. Patouillard, while examining some fungi sent from the Jura, noticed on the stems and leaves of some grasses small white spots, which presented a remarkable structure. These little tubercles were round, from 0.5 to 2 mm. in diameter, and sessile, hyaline, and gelatinous. Under the Microscope these tubercles were seen to be composed of colourless and branching filaments; a slight swelling can be observed at the end of these, and this forms an ovoid mass, which is the commencement of the spore. This spore is separated by a septum, and below this the filament emits a lateral branch which continues to elongate. The author gives a diagnosis of this plant, to which he has given the name of *Tubercularia chætospora*.

\* Soc. Bot. et Mycol. de France, Session Cryptogamique, 1887 (1888) pp. 29-30.

**Calostoma** Desv. (*Mitremyces* Nees).\*—Mr. G. Massee discusses the morphology of the genus *Calostoma* Desv. He was enabled in one case especially to follow the course of development from the period of differentiation of the gleba to that of dehiscence. The structure was found to be in every respect homologous with the peridium of the Phalloideæ, but differs in being entirely deliquescent at an early period. *Calostoma* is morphologically most nearly related to the genus *Geaster*, the homology in many respects being absolute, the differences at the same time extreme. The external peridium of *Geaster*, which splits in a stellate manner when ripe, corresponds to the exoperidium and endoperidium in *Calostoma*, the inner peridium in *Geaster* being the morphological equivalent of the spore-sac in *Calostoma*. Although the species of the genus *Calostoma* are, with two exceptions, restricted to narrow areas, the genus is widely distributed, extending from Massachusetts to the south of Tasmania, and from New Granada to Tasmania, with a vertical range from near the sea-level to 9000 feet in the Sikkim Himalayas. The author concludes with descriptions of the various species of the genus.

**Pimina**, a new Genus of *Hyphomycetes*.†—Mr. W. B. Groves describes a new genus of *Hyphomycetes* parasitic on the hyphæ of *Polyactis*, and on the leaves of *Passiflora princeps* and *P. quadrangularis* from Monkstown, Dublin. *Pimina*:—Hyphæ steriles repentes, hyalinae v. subcoloratae; fertiles erectæ, fuliginææ, sursum basidiis coronatæ. Conidia simplicia, hyalina, acrogena.

**Fungi of Fruit-trees.**‡—Herr F. v. Thümen enumerates 4202 species of parasitic fungus which attack 77 different kinds of fruit. The sweet chestnut appears to have the largest number of enemies, as many as 326 species, and the vine comes next with 323. The author remarks that when the same fungus appears on different organs of the same plant, it is constantly described under different names.

**Parasitism of the Truffle.**§—M. H. Bonnet states that *M. Tulasnei* first observed truffles entirely covered by their mycelium. Numerous white cylindrical threads were noticed, and these adhered to particles of earth by the extremity of their branches. Microscopical examination of these threads shows them to be composed of septated cylindrical filaments which are straight and parallel to one another. As to the anatomical relation of the mycelium with the surface of the fungus, the filaments which compose the first are all connected with the surface of the truffle, and it is not at all easy to discover where the peridium separates itself from its byssoid envelope.

**Fungus Parasitic on the Pine-apple.**||—M. J. de Seynes, in a recent work on the formation of acrospores, described a *Hyphomycete* belonging to the genus *Sporoschisma*, which he calls *S. paradoxum*. In this paper he adds more particulars about the same species. This fungus vegetates in the pulp of the fruit of the pine-apple. The mycelium is composed of filaments which intertwine with the elements of the parenchyma of the host; these filaments are colourless, and but

\* Ann. of Bot., ii. (1888) pp. 25-45. † Journ. of Bot., xxvi. (1888) p. 206.

‡ 'Die Pilze der Obstgewächse,' 126 pp., Vienna, 1887. See Bot. Centralbl., xxiv. (1888) p. 307.

§ Rev. Mycol., x. (1888) pp. 69-73. Cf. this Journal, 1887, p. 791.

|| Soc. Bot. et Mycol. de France, Session Cryptogamique, 1887 (1888) pp. 26-30.

little branched. The sporophore appears first as a small spherical eminence which becomes divided off by a septum from the mycelial cell. The sporophores bear at their summit the spores or conidia, which are unilocular and cylindrical.

**Fungus Parasitic on the Salt-fish.\***—Herr J. Brunchorst describes a mould-fungus parasitic on the salt-fish, and very destructive to it (*Torula pulvinata* Sacc., *Wallerina ichthyophaga* Johan-Olsen). It forms on the skin brownish, more or less hemispherical patches 1–3 mm. in diameter, or a brownish coating. It produces conidiophores, from which are abstracted brown spherical smooth conidia 4–5  $\mu$  in diameter, which, on germinating, divide into a kind of parenchymatous tissue which produces root-like hyphæ and flask-shaped conidiophores.

**“Rouge” of the Scotch Fir.†**—According to MM. Bartet and Vuillemin, the disease which is exceedingly destructive to Scotch firs in the neighbourhood of Nancy, known as “rouge,” is quite distinct from the “rouille,” and probably identical with that known in Germany as “Schütte.” It makes its appearance in the form of brown spots on the leaves, the spermogonia of *Leptostroma Pinastris* Desm. The best remedy for the disease they found to be the use of “bouillie bordelaise,” a preparation containing copper, which is also very efficacious against the *Peronospora* of the vine and of the potato.

**Parasites of the Peridiniæ.‡**—According to M. A. Dangeard, the Peridiniæ form a very interesting group, but as yet imperfectly known. The species which furnished a good part of the material for this paper was *Glenodinium cinctum* Ehrb., which is very common in fresh water. The body of this species is covered with a membrane of cellulose, its anterior part being shorter than the posterior; under the membrane yellow chromatophores may be seen. Multiplication takes place by longitudinal division, and spherical resting-spores having a thick membrane are formed.

The author then goes on to discuss the nature of the endogenous germs which exist in the Peridiniæ. In the case of *Glenodinium cinctum* the protoplasm incloses from one to four germs, and sometimes even a greater number may be observed; these germs are spherical or sometimes elliptical, and after a time give rise to an *Olpidium*. The endogenous germs do not belong then to the Peridiniæ, but are parasitic structures. The author describes various species of *Chytridium* in which the sporangia remain exterior to the host. *C. echinatum* was met with on *Glenodinium cinctum*; it is easily distinguished by the form of its sporange. The genus *Chytridium* can be divided into three sections, in the first two there is only one opening in the sporange for the escape of the zoospores, while in the third there are several.

**Disease attacking Amygdalæ.§**—M. P. Vuillemin describes a disease which attacked various Amygdalæ in Lorraine in 1887. The first examination revealed the parasitic nature of the disease; the laminæ of the leaves, petioles, and fruits were found covered with more or less numerous spots. If one of the spots is examined the spore may

\* Norsk Fiskeritidende, 1886, pp. 136–60, and 1888, pp. 65–80 (2 figs.) (Norwegian). See Bot. Centralbl., xxxiv. (1888) p. 133.

† Comptes Rendus, cvi. (1888) pp. 628–30.

‡ Morot's Journ. de Bot., ii. (1888) pp. 126–32, 141–6 (1 pl.).

§ Soc. Bot. et Mycol. de France, Session Cryptogamique, 1887 (1888) pp. 40–7.

be seen frequently in the centre of the altered region. The infecting spore is composed of a thread of cells, and is able to emit simultaneously several germinating tubes. The mycelium is composed of cylindrical filaments. The fungus hardly seems to comport itself like an ordinary parasite, but rather like certain *Sclerotinia* described by Prof. de Bary. The history of this fungus is not complete, as the perithecia have not been discovered: the conidiferous condition is, however, already known as *Coryneum Beijerinckii*; this is admitted to be a stage in the evolution of a *Sphaeria*.

**Haplococcus reticulatus.**\*—Prof. W. Zopf had described under the above name a presumed parasite of the flesh of swine. This he notes, however, was a mistake due to accidental contact with *Lycopodium* spores. He justly expects that his "youthful error may be gently overlooked."

**New Puccinia.**†—Herr G. Lagerheim describes a new species of *Puccinia*, which he calls *P. gibberosa*, found on leaves of *Festuca sylvatica*. It is distinguished by its large uredospores provided with a great number of germinal pores, by the paraphyses among the uredospores, and by the apex of the teleutospores being furnished with a few short warts instead of a larger number of horn-like protuberances.

**Sexual Organs in *Æcidium*.**‡—Mr. G. Massce has noticed, on leaves of *Ranunculus Ficaria*, a spherical welt of interlaced hyphæ, the tip of one thread situated in the centre of the mass ending in a clavate head rich in coarsely granular protoplasm. Being desirous of ascertaining whether the clavate body mentioned was in any way connected with the *Æcidium*, numerous young unopened peridia were cut, but without result; it was only when sections were made through those portions of the leaf first showing traces of the fungus in the form of a slight discolouration, or the appearance of spermogonia, that the clavate body in a ball of mycelium, which represented the initial stage of an *Æcidium*, was discovered. In this instance the object of search was in a more advanced stage, clearly showing it to be an oogonium, accompanied by an antheridium. The oogonium was much larger than the one first seen, in form irregularly oblong, measuring about 50 by 25  $\mu$ , terminal on a thread, from which it was cut off by a transverse septum, and containing finely granular protoplasm with numerous refractive globules. The author could see no trace of a nucleus.

The antheridium is cylindrical, about 40 by 12  $\mu$ , and, like the oogonium, filled with protoplasm and oil-globules, and terminated by a short lateral branch springing from a thread distinct from the one supporting the oogonium, as far as the two could be traced in the mass of mycelium. The antheridium is cut off from its supporting hypha by a transverse septum. The point of contact between the antheridium and oogonium was on the side turned away from the eye, so that the author is unable to state the exact manner in which fertilization is effected.

**Symbiotic Fungus in *Molgulidæ*.**§—M. A. Giard has observed in the kidneys of *Molgulidæ* various species of a new genus of Fungi (*Nephromyces*) living in apparent symbiosis. The genus seems most akin to

\* Biol. Centralbl., viii. (1888) pp. 144-5.

† Ber. Deutsch. Bot. Gesell., vi. (1888) pp. 124-6 (2 figs.).

‡ Ann. of Bot., ii. (1888) pp. 47-51 (1 pl.).

§ Comptes Rendus, cvi. (1888) pp. 1180-2.

*Catenaria* Sorokine. The sporangia are always terminal. The unicellular mycelium with fine filaments, the zoosporangia, zoospores, and zygospores are described. The two species especially studied were *Nephromyces Molgularum* from *Molgula socialis* Alder, and *Nephromyces Sorokini* from *Lithonephrya eugygranda* Lacaze Duthiers. M. Giard believes that the fungus is of use to the Tunicate which they infest, in helping to break up the waste products which would otherwise soon obstruct the ductless kidney.

Plasmodium of *Badhamia* and *Brefeldia*.\*—Mr. A. Lister finds *Badhamia utricularis* and *Brefeldia maxima* very favourable species for observing the phenomena connected with the plasmodium of the Myxomycetes. The plasmodium of *B. utricularis* can be kept in constant streaming movement on various kinds of woody fungi for more than a year, often covering large spaces, and it may with great facility be thrown into the sclerotium or resting-stage, in which condition it can be stored away for months, and brought back at any time into the active state by moistening. When placed in a glass box it will soon crawl up the sides, and is then in a favourable condition for observation.

The application of small pieces of any digestible substance excites the streaming of the plasmodium to an extraordinary degree; but it possesses a remarkable power of discriminating between different kinds of food. Thus raw potato-starch is scarcely if at all affected, while if the starch is swollen by moderate heat, it is rapidly digested. Cotton-wool is not affected. The plasmodium can be raised from a sluggish and almost quiescent condition to one of great activity by supplying it with *Agaricus campestris*, *Boletus flavus*, or the prepared hymenial surface of *Stereum hirsutum*, while the coarser fibres of the latter fungus are more slowly absorbed; and this is also the case with *Agaricus melleus* and *A. rubescens*, and still more so with *A. fascicularis*. The digestive principle of the plasmodium is not confined to any special part of the mass; it may take place in the streaming interior or in the hyaline margin alone.

The author is unable to suggest any explanation of the rhythmic streaming motion of the plasmodium, or of the causes of the sudden changes from a quiescent to a streaming condition, or of the impulse which occasions the change into sporangia, though the latter is no doubt favoured by hot weather.

In *Brefeldia maxima* Mr. Lister records the remarkable observation of an instance of spore-formation not confined by any inclosing wall.

The presence of nuclei and nucleoli in the plasmodium of *Badhamia* is easily proved. They are most readily detected by suddenly dipping into absolute alcohol cover-slips which have been smeared with it, and then staining with magenta.

**Mycological Notes.**†—M. P. A. Dangeard follows up his researches on the Chytridineæ ‡ by giving the descriptions of several new species.

*Chytridium Braunii* grows on *Apiocystis brauniana*; the sporangia are oval, and each forms at maturity from fifteen to twenty-five zoospores. *C. zoophthorum* resembles the preceding species, but the radicular system is much more developed and more strongly branched; it attacks Rotifers.

\* Ann. of Bot., ii. (1888) pp. 1-24 (2 pls.).

† Soc. Bot. et Mycol. de France, Session Cryptogamique, 1887 (1888) pp. 21-5.

‡ See this Journal, 1887, p. 234.

In reference to *Dentigera*, which has been established as a section of *Chytridium* by M. Félix Rosen,\* if all the species whose sporangia possess a basilar swelling are placed in the genus *Rhizidium*, the section *Dentigera* ought not to remain in the genus *Chytridium*, but become a part of the genus *Rhizidium*.

When the author in his former paper gave a description of the genus *Sphærita*, he was unable to follow the development of the cysts for want of proper material. Since then the cultures have been continued, and a number of cysts obtained; their development resembles that of the sporangia, but from the first the protoplasm is denser, and there are no sexual phenomena apparent. Their form is sometimes spherical; more often they are elongated and elliptical.

The author then describes a new Pyrenomycete which attacks *Salicornia herbacea*, under the name of *Pleospora Salicorniæ*.

#### Protophyta.

Relationship between *Phormidium* and *Lyngbya*.†—M. M. Gomont has been able to follow the course of development of an *Oscillaria*, the study of which was interesting as bearing on the relationship between the genera *Phormidium* and *Lyngbya*. The plant (*Oscillaria viridis*), which presented all the characters of a *Phormidium*, was cultivated in two ways—in a vase filled with water, and on a brick which was simply kept moist. The trichomes in both cases became strongly flexuous, and were surrounded by solid sheaths. These sheaths had, however, no tendency to agglomerate, and the filaments could be separated without tearing by the aid of needles. In fact, it appeared as a true *Lyngbya*. It remains then proved that the same plant can possess the characters of *Phormidium* as well as those attributed to *Lyngbya*.

Cultures of *Cladotrix dichotoma*.‡—M. E. Macé states that *Cladotrix dichotoma* Cohn is a filamentous bacterium found in fresh or salt, but especially abundant in stagnant water. In the cultures made with gelatin, the colonies appear on the fourth or fifth day as very small yellowish points surrounded by a brown ring. All the cultures emitted a somewhat mouldy odour. On the filaments of the cultures true ramification could be observed; on the side of the filament a rupture appeared which was indicative of a lateral branch. This bud enlarged and formed a cylindrical prolongation until it attained to the same size as the mother filament. On the same filament, frequently a series of these lateral branches at different stages of development could be observed, and it was thus possible to follow the transformations. The author concludes by stating that *Cladotrix dichotoma* appears to be a saprophytic bacterium inoffensive to men and animals. It very probably may take a large part in the calcareous concretions which are found deposited in the pipes used to conduct certain waters. The bacterium brings about the precipitation of lime salts around its very long filaments, in the same manner as *Leptothrix buccalis* occasions the precipitation of the lime salts in saliva.

New *Pleurocapsa*.§—Herr G. Lagerheim describes a new species of this genus, hitherto exclusively marine, *P. fluviatilis*, growing attached to mosses on wet planks in the canal of the Dreisam near Freiburg-i.-Br.

\* See this Journal, 1888, p. 1002.

† Soc. Bot. et Mycol. de France, Session Cryptogamique, 1887 (1888) pp. 18-21.

‡ Comptes Rendus, cvi. (1888) pp. 1622-3.

§ Notarisia, iii. (1888) pp. 429-31 (1 fig.)

Colouring matter of the waters of the Lake of Bret.\*—Herr J. B. Schnetzler states that last autumn a red colouring matter, held in suspension in the waters of the Lake of Bret, was brought for his examination. Under the Microscope it appeared as irregularly lobed masses of a red colour, and consisted of micrococci. These the author identified as the zoogloea of *Beggiatoa roseo-persicina*. A second search was made this spring in the Lake of Bret for the red colouring matter, which, however, could not be found but, instead, a bluish-black substance. When this was examined, a number of diptera were seen, the decomposition of which served as the points of departure of the long colourless filaments of *Beggiatoa*.

*Saccharomyces ellipsoideus* and its Use in the Preparation of Wine from Barley.†—M. G. Jacquemin gives the details of some experiments which were made to determine whether *Saccharomyces ellipsoideus* is a stable or merely an abnormal form of beer-yeast developed under special conditions, and liable to revert to the original form; but these experiments are not yet complete. The action of elliptical yeast on barley-wort produced a liquid with an alcoholic strength of 6°, containing 60 grams of dry extract and 3 grams of ash per litre. It had the following percentage composition:—Alcohol, 4·80; reducing sugar, 1·00; dextrine, 3·00; albuminoids, &c., 1·28; glycerol, 0·20; succinic acid, 0·04; acetic acid, 0·02; potassium hydrogen tartrate, 0·25; ash, 0·23; water, 89·18. This liquid has an agreeable flavour, and contains a greater proportion of albuminoids and phosphates than wine from grapes. It differs from the latter in giving an abundant precipitate with tannin. In these experiments it was found that the elliptical wine-yeast remained stable for eighteen months, and it would therefore seem to be quite distinct from beer-yeast. When wine obtained in this way from barley is distilled, it yields brandy of good flavour, whilst the brandy from wine produced by beer-yeast has a bad flavour.

Organic nourishment of Beer-ferment.‡—M. E. Laurent has tried the nourishing effect of different organic bodies on beer-ferment, the object being to find from what organic bodies glycogen could be formed by the ferment; as there can be no doubt, after the results obtained by Errera,§ that this body plays the part of reserve carbohydrate in fungi as in animals. The author then gives a long list of bodies which were to a greater or less extent assimilated:—e. g., acetates, lactates, glycerin, mannite, asparagine, salicin. In many cases the presence of glycogen has been determined in these bodies.

Scheuerlen's Cancer Bacillus.¶—Dr. E. Van Ermengem concludes from experiments made on dogs, guinea-pigs, and rats that Scheuerlen's cancer bacillus is non-pathogenic. Two ccm. of the pure cultivation were injected, and after two months all the animals were quite well. The author finds that the pseudo-cancerous bacillus is an organism very common in the air, dust, soil, &c., and identifies it with the "bacille rosé" found in an impure cultivation of bacillus tuberculosis.

\* Bull. Soc. Vaud. Sci. Nat., xxiii. (1888) pp. 152-5. Cf. this Journal, 1887, p. 1007.

† Comptes Rendus, cvi. (1888) pp. 613-4.

‡ CR. Soc. R. Bot. Belg., 1888, pp. 131-40.

§ See this Journal, ante, p. 96.

¶ Bull. Soc. Belg. Micr., xiv. (1888) pp. 92-5.

**Iron-bacteria.\***—Bacteria which assume a rust-coloured hue were denominated iron-bacteria by Ehrenberg, who found that this coloration was due to the presence of compounds of iron oxide deposited in the substance of the jelly, and regularly distributed. The exact significance of this deposition of iron and the conditions under which it is called forth, are at present problematical. According to one view, that of Cohn, the brown coloration is due to the deposition of iron oxide by the vegetative activity of the cells, just like silex in diatoms or carbonate of lime in the cell-membrane of Melobesiaceæ. The other view is that the process is purely mechanical, and is effected by the deposition of iron compounds dissolved in water in the gelatinous parts.

To ascertain which and how far either of these views were correct, Herr S. Winogradsky made experiments chiefly with *Leptothrix ochracea* Ktz.

(1) When finely-powdered iron oxide was placed in water containing colourless *Leptothrix*, no brown staining was produced; but directly water containing carbonate of iron in solution (Pyrmont, Schwalbach) was used, in 10–15 hours a yellowish-brown colour appeared.

(2) The co-operation of the living plasma is shown by the fact that where the brown coloration is produced, there is no deposit of iron oxide in the immediate vicinity; consequently the effect is not due to the action of the oxygen in the air. Moreover, the sheaths are only stained when the cells are alive.

(3) Without the presence of iron oxide, *Leptothrix ochracea* does not grow. This is clearly shown by changing the fluids; when the water contains no iron the threads stop their development, but directly it is added growth proceeds again.

(4) The oxidation process is therefore as follows:—The salts of the oxide of iron are eagerly taken up by the cells, oxidized in the protoplasm, and the compounds formed excreted by the cells. These compounds are soluble; and after twenty-four hours the colour may usually be removed by washing the threads in water, especially if it contain CO<sub>2</sub>. Very dilute acids seem to remove the brown hue most efficaciously, but are not always successful.

(5) *Leptothrix ochracea* can grow in water which contains very little organic matter, e. g. the natural ferruginous waters. The addition of 0·005–0·01 per cent. butyrate of lime or acetate of soda to Strasburg water sufficed to make this bacterium grow well.

The author does not draw any conclusion from the foregoing experiments, except that the oxidizing power of the cells of iron-bacteria must be extremely great, but promises a more complete account in some future publication.

**Bacillus muralis.**—Prof. A. Tomaschek,† in reply to Prof. A. Hansgirk, who identifies *Bacillus muralis* with *Glaucothrix gracillima* Zopf,‡ points out that the rods in *Glaucothrix* (*Aphanothece caldariorum* Richter) are distinctly green, while those of *B. muralis* consist of a plasma which is perfectly homogeneous and almost transparent. The author then proceeds to call attention to the endogenous spore-formation of *B. muralis*. The commencement of this process is indicated by a number of strongly refracting roundish corpuseles with a bluish reflex, collecting together

\* Bot. Ztg., xlv. (1888) pp. 261–70.

† Bot. Centralbl., xxxiv. (1888) pp. 279–83 (2 figs.).

‡ See this Journal, *ante*, pp. 276–7.

from the ends and gradually drawing together towards the more central parts. This is the case chiefly with the two-celled rodlets. In the longer ones the corpuscles make their appearance about the middle of the rodlet. When these forms have attained a certain size and distinctness, the plasma surrounding them gradually clears up and they seem as if environed by a bright halo. The brightness of the spore afterwards disappears and it assumes the pale homogeneous appearance of the vegetative rod, and, though still roundish, attains the ordinary breadth of the rods. In this transition from the spherical to the cylindrical shape no striation of the spore membrane is observable. The membrane, like the parent-cell, seems to disappear by dissolution or absorption. The spores, however, remain inclosed in a general gelatinous investment, which may contain from two to eight rodlets. The arrangement of these rodlets in relation to the common envelope and to each other is quite irregular.

The author then proceeds to notice the effect of iron or its rust on *B. muralis*. The accidental mixture of some scales of rust produced a dark olive-green colour in the zoogloea mass surrounding the rust. Examination under the Microscope showed that each cell-membrane was now distinctly laminated or consisted of a number of concentric layers.

Two mosses were found thriving luxuriantly on the zoogloea, *Ephemereum tenerum* and *Ephemerella recurvifolia*.

Prof. A. Hansgirg\* replies at some length to Prof. Tomaschek, and at the same time takes the opportunity of copiously recapitulating certain facts bearing on the subject of jelly-formation by Algæ.

Tomaschek had pointed out that *B. muralis* differs from *Aphanothece caldariorum* Richter in being green. This, says the author, is of no consequence, inasmuch as Algæ grown without access of light become blanched. He considers that not only is the green rod of *B. muralis* identical with its colourless variation known as *Plectonema gracillimum* (*Glaucothrix gracillima* Zopf), but that there exists a coccus-form derived by continuous subdivision which is common to *Plectonema gracillimum* and *B. muralis*.

The author points out that Tomaschek himself throws some doubt on the truly bacillous nature of *B. muralis*, as he was unable from direct observation to trace the transition from the motionless rod to the mobile condition, a stage which is easily ascertainable in the transformations of real bacilli.

The author then turns to the highly refracting granules found at the ends of the rods both in *Aphanothece caldariorum* and *B. muralis*. In the latter Tomaschek considers that they are intimately connected with endogenous spore-formation, while Prof. Hansgirg says that there is no difference between the corpuscles, and is disposed to regard them simply in the light of the resting cells (aplanospores, cysts) of Algæ and Fungi.

Referring to the gelatinous laminated sheath, Prof. Hansgirg shows that the formation of jelly is not uncommon in certain kinds of Algæ, and that this sheath may consist of several layers, the innermost being the most recent.

**Spore-formation in Bacteria.**†—Dr. A. Prazmowski deduces from his experiments on micrococcus and bacterium that the earlier view

\* Bot. Centralbl., xxxv. (1888) pp. 54-7, 102-9 (2 figs.).

† Biol. Centralbl., viii. (1888) pp. 301-7.

respecting the fructification of bacteria is more correct than that at present adopted, which was promulgated by de Bary and Hucppe. This doctrine, which also served as a means of classification, subdivided bacteria into the endosporous and the arthrosporous, according as on the plasma there arose small, refracting globular bodies surrounded by a definite membrane, which were set free from the parent cell by some process of softening of the parental cell membrane or not. When these spores found suitable conditions, they lost their refracting qualities, their investing membrane swelled up, and they began to assume the appearance of the predecessor from which they had sprung. In the arthrosporous bacteria it was understood that any single individual, without going through the process of endogenous formation, was able to assume a reproductive condition, and thus start a new series similar to that from which itself had been developed.

The micrococcus selected by the author was the coccus which has been long associated with the ammoniacal fermentation of urine. On account of its cruciform fission the author calls it *Merista ureæ*. Notwithstanding that this urinary ferment had been subjected to searching investigation (Pasteur, Leube, Cohn, &c.), spore-formation had not been observed, and yet spores are regularly formed as soon as the urinary fermentation is drawing to a close. When added to sterilized urine, there are found at the commencement of the process, and as long as fermentation is energetic, relatively large cocci of an oval or elliptical form, the long diameter of which varies from 1.5 to 2.2  $\mu$ , and the short from 0.8 to 1.2  $\mu$ . Dividing cruciformly they form diplo- or tetra-cocci which may accumulate into irregular heaps or shorter or longer chains. Vegetation having come to an end, the relatively large form of coccus gives place to a much smaller spherical cell which shows special differences from the first kind. The one sort is large, strongly refracting, and invested in a firm dark membrane, the others, which show several gradations of size, have pale contents and no noticeable contour. The bright, refracting cells are really spores, the pallid cells are in a condition of involution, that is, are dead vegetative cocci.

The spores are distinguished by their great resistance to injury. They withstand prolonged drying, and are only killed by a temperature of 100° C., resisting 90° C. for a minute, and 80° C. for 2 minutes. Dried under a cover-glass, they show a double outline, the outer of which is dark and thick, the inner thin and delicate. Placed in fresh urine, they germinate with appearances similar to endogenous spores, becoming pale, assuming the form and size of the vegetative cocci, and multiplying by cruciform fission. With regard to the spore membrane, it could not be ascertained by direct observation if it originated as a thickening of the primary membrane of the vegetative cell, or was a new formation, the parental cell membrane being dissolved. Apart from this, which the author considers of little importance, the spores of *Merista ureæ* behave so much like the endogenous spores of other bacteria that their endogenous origin must be conceded. This view is strengthened by observations on bacteria obtained from the excrement of cattle. In their early stage in pure cultivations they are short rods 2.5 to 4  $\mu$  long, and 1.0 to 1.5  $\mu$  broad, usually single or in pairs, more rarely in very short chains. On the 3rd or 4th day a dirty white scum forms on the surface, and this afterwards falls to the bottom. It is in this scum that the spore-formation takes place. The rodlets become thickened, and at the

pyriform expansion a spherical highly-refracting spore is formed. Sometimes the parental membrane is dissolved, sometimes it is retained, and invests the spore even for months. Placed in fresh nutrient solution, the spores present appearances similar to those of *Merista ureæ*, they become pallid, larger in one direction, and divide by fission. During the act of germination no separation of a membrane is observable. Dried on a cover-glass, the spores are seen to be highly refracting, and surrounded by a double outline, the outer contour being thick and black, the inner one fine and thin. In their resistance to high temperatures they closely resemble the spores of *Merista ureæ*. This consonance in structure, germination, and general characteristics, shows that no difference exists between spores of faecal bacteria and of urinary ferment—in other words, the latter develop endogenously.

The author concludes by pointing out that where spore-formation can be controlled throughout its whole course, only one form of fructification has been observed, namely the endogenous. The cases of arthrosporous fructification only refer to bacteria wherein, on account of their smallness, or the special form of the vegetative or fructifying cells, it was impossible to follow the processes throughout their course.

**New Marine Bacterium.\***—M. A. Billet has observed in sea-water a new *Bacterium*, to which he has given the name of *B. Laminiarizæ*; and describes its life-history and its morphological variations. In the filamentous or initial stage it consists of colourless, immobile filaments, which appear to consist at first of homogeneous and uninterrupted protoplasm; later, however, fine transverse striæ can be detected. The protoplasm then commences to segment, the separate portions being divided by more or less pronounced intervals, and the filamentous sheath can be distinguished. The second or dissociated stage is thus reached. The third stage is characterized by a peculiar disposition which affects the filaments of the initial stage, these latter interlacing one with another and extending and forming variable groups, which finish by spreading like a veil on the surface of the liquid. The fourth stage is characterized by the formation of the zooglææ, which are aggregates of bacterian elements, and are enveloped in a common gelatinous matrix. The author has only been able to study imperfectly the formation of the spores. On the surface of certain filaments roundish corpuscles with a thick membrane were noticed; these were probably the endospores.

**New and Typical Micro-organisms from Water and Soil.†**—In their paper on Micro-organisms obtained from soil and water, the authors, Mrs. Grace C. Frankland and Dr. Percy F. Frankland, point out the striking difference between the aerial and aquatic micro-organisms, micrococci being predominant forms amongst the former, whilst bacillar forms are almost exclusively present in water. In fact, all the aquatic forms described are bacilli.

With regard to the chemical action which these micro-organisms exert upon certain solutions containing salts of ammonia and of nitric acid, it was found that while none of the forms were found to oxidize ammonia, either to nitrous or nitric acid, several of them exerted a powerfully reducing action on nitrates, converting the latter into nitrites; others

\* Comptes Rendus, cvi. (1888) pp. 293-5.

† Proc. R. Soc. Lond., xliii. (1888) pp. 414-8.

were without any action on nitric acid; and others again caused the disappearance of an appreciable proportion of the nitric acid without the production of a corresponding amount of nitrite. These differences in the behaviour of micro-organisms when introduced into solutions containing nitrates, are capable of furnishing important data for distinguishing between forms which otherwise present a very close resemblance.

Thus *Bacillus subtilis* and *Bacillus cereus*, which closely resemble each other, can be easily distinguished by their behaviour towards the nitrate solution; for whilst both grow luxuriantly in this medium, *Bacillus subtilis* has no action on the nitric acid, which can be quantitatively recovered; *Bacillus cereus* powerfully reduces the nitrate with formation of nitrite.

The nitrate solution employed contained potassium phosphate, magnesium sulphate, calcium chloride, calcium nitrate, invert sugar, peptone, and an excess of calcium carbonate.

The following is a brief account of the various micro-organisms:—

*Bacillus arborescens*, under a high power ( $\times 1000$ ) is a slender bacillus giving rise to long wavy threads; no spores were observed. In drop cultivations it is seen to be vibratory. On gelatin plates ( $\times 100$ ) the centre of the colony consists of a thin axial stem, with root-like branches from each of its two extremities, which, when largely developed, give the whole colony the appearance of a wheat-sheaf. The plate is slowly liquefied. On potatoes it produces a fine deep-coloured orange pigment. On nitrates it has no action in the solution employed.

*Bacillus aquatilis*.—A slender bacillus giving rise to wavy threads. No spores were observed. The individual bacilli in drop cultivations show only an oscillatory motion. Gelatin is liquefied very slowly by this bacillus, which grows with great difficulty in all the media except the aqueous solution, wherein it grows abundantly. It does not convert nitrate into nitrite.

*Bacillus liquidus*.—A short fat bacillus of very variable dimensions. In drop cultivations they are exceedingly motile and usually in pairs. Gelatin is rapidly liquefied into large circular depressions with clear contents. On agar is produced a clear shining expansion, and on potato a thick flesh-coloured pigment. The nitrate in the aqueous solution is powerfully reduced.

*Bacillus vermicularis*.—A large bacillus with rounded ends giving rise to vermiform threads. It produces fine oval spores. In drop cultivations it shows oscillatory motion only. It powerfully reduces nitrates to nitrites.

*Bacillus nubilus*.—A fine slender bacillus giving rise to wavy threads; no spores observed. In drop cultivations the isolated bacilli show violent circular movements; on gelatin plates only patches of cloudy expansions with, in some cases, a faintly defined centre. Gelatin is rapidly softened and liquefied. In the aqueous solution it reduces a small proportion of nitrate to nitrite.

*Bacillus ramosus*.—A large bacillus much resembling *B. subtilis*, giving rise to long threads and spores which are, however, rounder in shape than those of the latter organism. Slight oscillatory movements seen in drop cultivations. On gelatin plates the colonies show a cloudy centre with tangled root-like branches which extend in every direction. The gelatin is liquefied. In tubes the gelatin first becomes impregnated with fluffy ramifications, later liquefaction ensues, and a tough pellicle

forms on the surface. On potatoes there forms a dry, continuous, almost white surface expansion. Nitrates are powerfully reduced in the aqueous solution.

*Bacillus aurantiacus*.—A short fat bacillus of variable dimensions. No spores were observed. In drop cultivations the isolated bacilli are seen to be motile. On gelatin plates it produces bright orange pin-heads; on potatoes a brilliant red orange pigment not extending far beyond the point of inoculation. Nitrates are only slightly reduced to nitrites.

*Bacillus viscosus*.—A short bacillus about three or four times as long as broad, occurs mostly in pairs; no spores were seen; is exceedingly motile. Gelatin is rapidly liquefied, becoming viscid and green-coloured; on agar the whole surface quickly assumes a green tint; no reduction of nitrates in the aqueous solution.

*Bacillus violaceus*.—A bacillus of variable thickness, on agar being more slender; sometimes gives rise to short threads. Spore-formation observed. Vibratory motions observed in drop cultivations. It produces on agar a dark violet expansion. Powerful reduction of nitrates to nitrites.

*Bacillus diffusus*.—A slender bacillus, frequently in pairs, but occasionally in long undulating threads. No spores observed. Oscillatory movements seen in the drop cultivations. On gelatin plates the colonies on reaching the surface give rise to a halo which, extending from the centre, spreads considerably, and is composed of a thin mottled expansion. Nitrates are slightly reduced.

*Bacillus candicans* varies in form both in the same cultivation and in different media; sometimes looks like a micrococcus, sometimes shows a tendency to grow into short threads. On gelatin plates the surface expansions resemble milk drops. Has no reducing action on nitric acid, but grows abundantly in the medium.

*Bacillus scissus* much resembles *B. prodigiosus*. No spores observed. Is seen to be very motile in drop cultivations. On gelatin plates it produces light-green surface expansions which, under a low power ( $\times 100$ ), are seen to be of a fine granular texture, and both their edges much frayed out. In tubes the gelatin and agar become tinted green. It powerfully reduces nitrates to nitrites.

Of the foregoing the first nine were derived from water, the last three from garden soil.

**Baumgarten's Pathological Mycology.\***—This part of Prof. Baumgarten's work on pathological mycology treats specially of the pathogenic cocci, which are exhaustively discussed.

\* Baumgarten, P., 'Lehrbuch der pathologischen Mykologie,' ii. Hälfte, 1 Halbband, 48 Abbildungen, Braunschweig, 1887.



## MICROSCOPY.

## a. Instruments, Accessories, &amp;c.\*

## (1) Stands.

Thury's Five-tube Microscope.—M. Thury has designed, and the Geneva Society for the Construction of Physical Instruments have constructed the Microscope with five body-tubes shown in fig. 120.

FIG. 120.

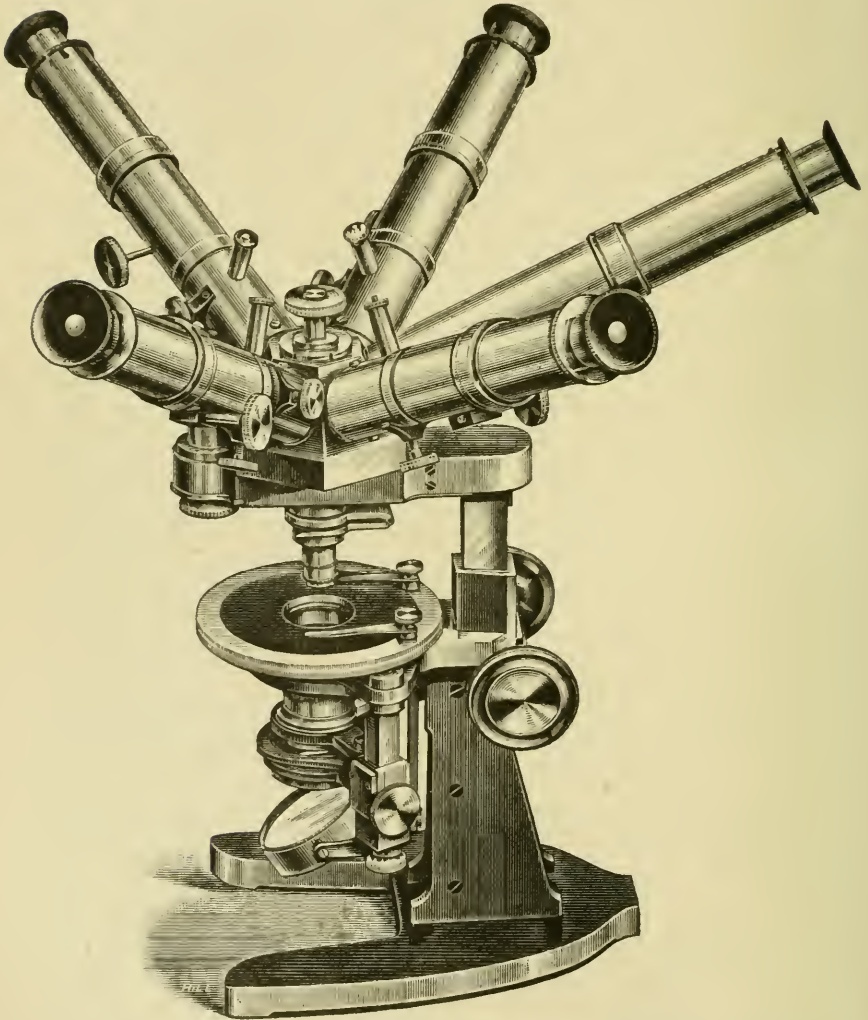

\* This subdivision contains (1) Stands; (2) Eye-pieces and Objectives; (3) Illuminating and other Apparatus; (4) Photomicrography; (5) Microscopical Optics and Manipulation; (6) Miscellaneous.

The principle of the instrument is the same as was described in this Journal, 1887, p. 796, where a Microscope with four tubes was figured. A totally reflecting prism is placed over the objective, and as this is rotated by the milled-head at the top, the image is thrown into each of the tubes in succession, thus enabling a Professor to show the same object to various members of his class.

Four of the tubes have each two screws for centering in two rectangular directions. They also have each a rack and pinion for focusing. An unavoidable difficulty of the instrument is, that the object appears differently placed to the different observers, but a mark in the field of each of the four tubes shows which was the right-hand side of the object to the observer using the first tube.

**Schieck's Meat-examining Microscope.**—Herr F. W. Schieck has applied to this Microscope (fig. 121), an arrangement for inclination,

FIG. 121.

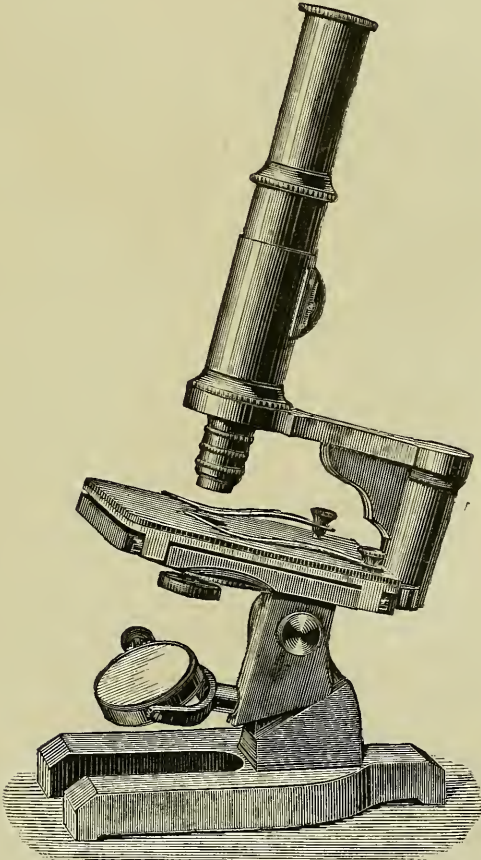

which, although adopted in the case of small instruments, has not been hitherto applied, so far as we know, to those of the size of his

Microscope, which is stated to be 12 in. high, stage 4 in. by 4 in., "weight  $2\frac{3}{4}$  kilo." The tail-piece attached to the under side of the stage turns on an axis projecting laterally from the standard, the latter having a diagonal stop-piece at the bottom, against which the end of the tail-piece, which is sloped off as shown in the fig., abuts when the instrument is upright.

**Schieck's Travelling Microscope.**—We are reminded that Herr Schieck some years ago brought out the Microscope shown in fig. 122, which anticipates those of Dr. Zeiss described *ante*, p. 637, inasmuch as the prolongation of the stem beneath the stage slides in a socket on the base, and can be clamped at any point.

FIG. 122.

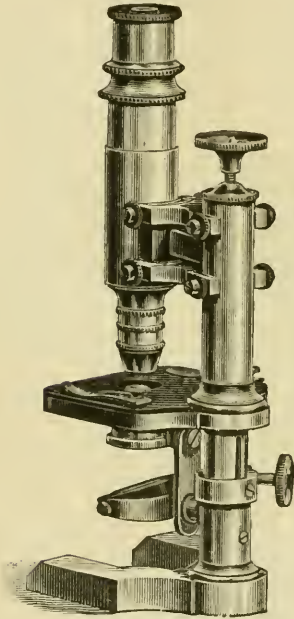

The object of this device was stated to be to enable the instrument to go into a case of reduced dimensions for travelling.

**Zeiss's IIa Microscope—Babuchin's Microscope.**—In the description of these Microscopes, *ante*, p. 637, we should have explained that by means of the screw at the back of the limb, the fine-adjustment can be thrown out of gear when travelling, thus preventing the point of the micrometer-screw from getting damaged.

**Leitz's Demonstration Microscope—Old Demonstration Microscope.**—The design of this Microscope sufficiently appears from fig. 123. The form of the frame in which the body-tube socket screws, is devised to enable it to be held in the hand and passed round for class demonstration (the object being viewed by transmitted light), and at the same

time to allow of its being rested on the table when not in use.

We are forcibly reminded by this Microscope of the tendency to the repetition—with more or less modifications—of antique forms. On page 109 we reproduced a figure from the 'Acta Eruditorum' (1686), illustrating the employment of Campani's Compound Microscope on opaque and transparent objects, and it is evident that Leitz's Demonstration Microscope might be substituted for Campani's, the difference of form being only a simplification certainly not suggestive of an interval of upwards of two centuries in their construction.

Fig. 124 shows what appears to have been a Demonstration Microscope of the last century. It is constructed of wood and cardboard, and is apparently a modification of Culpeper and Scarlet's Microscope figured in Dr. Robert Smith's 'Opticks' (Cambridge, 1738, 2 vols. 4to.). The body-tube slides in a socket for focusing, and has a draw-tube in which the lenses of a Huyghonian eye-piece are applied respectively above and below, the draw-tube serving not only to increase the amplification, but also (probably) as a means of focusing the image more accurately, as in some of the modern "miniature" Microscopes. Mounted transparent

FIG. 123.

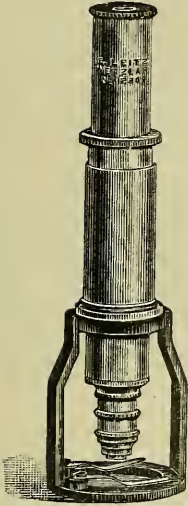
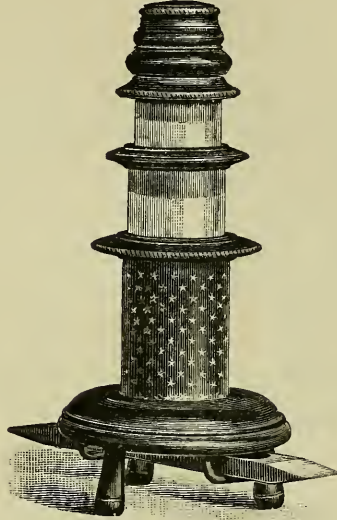
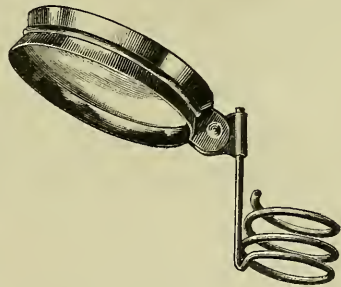

FIG. 124.



objects were viewed on "sliders" passing through a bent staple on either side of the under face of the base, the instrument being directed to the source of light. For viewing opaque objects, some such method as that shown with Campani's Microscope (above quoted), was probably employed.

FIG. 125.



**Dentist's Examining Glass.**—In Mr. S. S. White's Catalogue of Dental Materials,\* we find an examining glass figured, consisting of a low-power lens (fig. 125), mounted in a metal ring, hinged on a socket that slides on a rod terminating in a spiral, by which it is carried on the finger in examining teeth, &c. In practice we should expect the difficulty of holding the lens steady a great drawback to its utility.

FIG. 126.

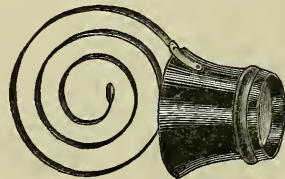

**Bausch and Lomb Optical Co.'s "Watchmaker Glass."**—The Bausch and Lomb Co. have obtained a patent for the application of a spiral spring to a watchmaker's glass to encircle the head and thus keep the lens in position. We are unable to say how far this arrangement has been found to be of practical utility, nor can we trace its origin with certainty. We have, however been informed that such a device was in use in the last century, if not earlier.

\* Philadelphia, 1877, p. 227.

Ganz's Pinakoscope with Dreyfus's Reflector. — Herr J. Ganz's instrument, which was exhibited at the Wiesbaden Exhibition last year, is practically a Sciopticon,\* but for microscopic purposes it is fitted with a stage and carrier for objectives. Mr. L. Dreyfus (now of Wiesbaden), has added a reflector fixed in a short tube which can be pushed over the end of the tube carrying the objective (fig. 127), so that the images in place of being shown on a screen, can be thrown on the table, an arrange-

FIG. 127.

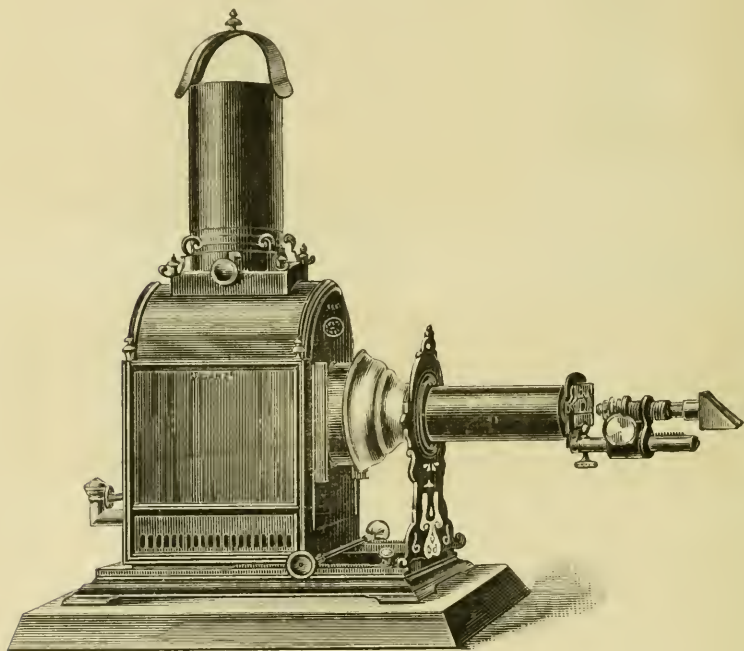

ment which is very effective for drawing objects. Mr. Dreyfus writes, "By the aid of this apparatus we make all the drawings used in the lectures here with perfect ease, sitting at the table. The drawing can be left, and finished whenever we have time again."

The illumination being obtained from a mineral-oil lamp is not strong enough to show objects under powers higher than a  $\frac{2}{3}$  in. objective.

Tri-ocular, Quadri-ocular, &c., Prisms.—Figs. 128 to 132 show the various prisms belonging to the Microscopes described in this Journal, 1887, pp. 796–800. Fig. 128 is the prism over the objective of Nachet's double-bodied Microscope, fig. 129 that of Nachet's triple-bodied, and fig. 130 the small four-sided prism for which M. Nachet (pp. 1067–8)

\* Cf. J. Scherrer, 'Das Pinakoskop und seine Anwendung,' &c., 61 pp. and 30 figs., 8vo, Speicher, 1886. Cf. also Boll. Accad. Med. Roma, 1886, pp. 178–92.

claimed priority over that of Prof. Harting (p. 799) shown in fig. 131. The prisms of Mr. Ahrens's Tri-ocular Microscope (p. 799) are shown in fig. 132.

FIG. 128.



FIG. 129.

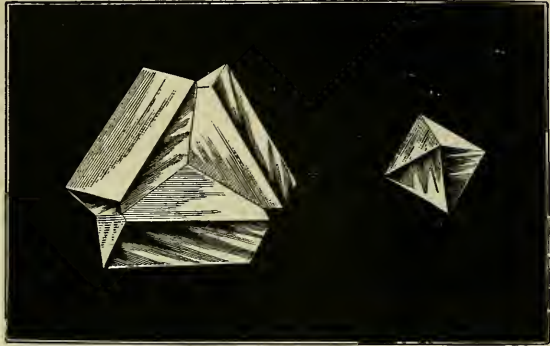
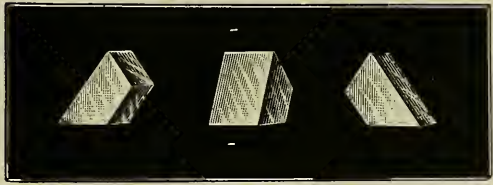

FIG. 130.

FIG. 131.



FIG. 132.



HEURCK, H. VAN.—Le Microscope Anglo-Continental ou Microscope d'Étudiant de M. Watson and Sons. (Watson and Sons' Anglo-Continental or Student's Microscope.)

[Includes also a photomicrographic apparatus.]

*Journ. de Micr.*, XI. (1888) pp. 314-8 (2 figs.).

SEAMAN, W. H.—American and Foreign Microscopes. *Science*, XI. (1888) p. 120.

(2) Eye-pieces and Objectives.

Zeiss's "Compensation Eye-piece 6 with 1/1 Micron-division."\*—The graduation of the eye-piece micrometers hitherto made is arbitrary, and has no intimate connection with the magnifying power of the objectives used with them for micrometric measurement. For this reason it is necessary to have a table giving the value of an interval for each objective and eye-piece; for example, the interval may be—

With eye-piece 2, for objectives A, C, E, and 1/12 = 16, 6·7, 2·7, 1·82  $\mu$ .

With eye-piece 3, for the same objectives = 14, 6·0, 2·4, 1·67  $\mu$ .

If, then, the image of an object observed with a 1/12-in. homogeneous-immersion objective covers 3·75 intervals of the micrometer eye-piece 2, the true dimension is 3·75  $\times$  1·82 = 6·82  $\mu$ .

\* From the description issued by Dr. Zeiss. Cf. also K. Schliephacke in *Flora*, lxxi. (1888) pp. 33-44.

The rational gradation in the focal lengths of the apochromatic objectives has made it possible to essentially simplify both in calculation and tabulation the measurements to be made with them. The micrometer eye-piece (fig. 133) used is a compensation eye-piece, No. 6, of the usual form (new construction), and a graduation in which the intervals for an ideal objective of 1.0 mm. focal length (with normal tube-length) are  $0.001 \text{ mm.} = 1 \mu$ .

FIG. 133.

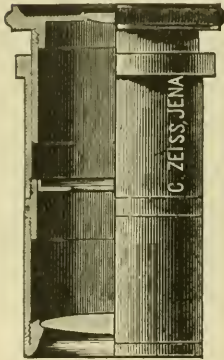

The value of an interval rises in the same ratio as the focal lengths of the objectives, and is represented by the same numbers, it is therefore

2.0 $\mu$	for apochromatic	2.0 mm.	{ (1.30 and
2.5 "	"	2.5 "	1.40 N.A.)
3.0 "	"	3.0 "	{ (1.30 and
4.0 "	"	4.0 "	1.40 N.A.)
8.0 "	"	8.0 "	
16.0 "	"	16.0 "	

so that the same number denotes the interval in terms of  $\mu$  and the focal length in mm. The use of this eye-piece therefore renders a special table unnecessary.

Measurements made in this way will always be correct within a slight percentage, since individual variations of particular eye-pieces and objectives always lie within very small limits. If, however, it is necessary in special cases to find a very exact value of an interval for a particular objective, it must be tested in the ordinary way by a stage micrometer, and then the small deviation in the value of an interval from its true value for a given objective, as expressed by its number, can be corrected by a slight alteration of the tube-length. In such a case the objective in question is focused upon a stage micrometer, and if an interval of the micron-division does not cover exactly so many thousandths of a mm. as are given by the focal length of the objective, the correction is made by a small lengthening or shortening of the tube-length, and the exact tube-length shown by the graduations of the draw-tube noted for each objective.

#### American v. Foreign Microscopes; the Verdict of an Impartial Expert.

[Results of Dr. H. J. Detmers' examination of objectives by Leitz, Seibert, and Zeiss.] *St. Louis Med. and Surg. Journ.*, LV. (1888) pp. 160-3.

### (3) Illuminating and other Apparatus.

**Eternod's Drawing-board.\***—Prof. A. Eternod recommends the use of a drawing-board invented by him, and which he has found useful for microscopical drawing, as it is very stable and easy of management. It consists of a shallow box (fig. 134, a), the sides of which are strongly

\* *Internat. Monatschr. f. Anat. u. Histol.*, ii. (1885) pp. 269-70 (6 figs. of a plate).

morticed together; a drawing-board (fig. 134, *b*) made of poplar; a rackwork arrangement (fig. 134, *c*) by which the board can be fixed in or altered to any desired position with great rapidity; and a brass catch by which it can be fixed instantly with a turn of a screw (fig 134, *d, e*).

The advantages of this apparatus pointed out are: (1) it can be raised

FIG. 134.

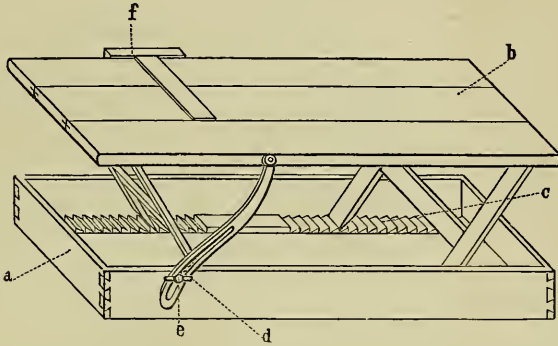

or lowered to any level, and still kept in the horizontal position (figs. 134, 136, 138, 139); (2) it can be placed obliquely (figs. 135 and 137); (3) it

FIG. 135.



FIG. 136.



can be displaced laterally (fig. 138), and obliquely (fig. 137); (4) when folded up, the apparatus only takes up a very small space; the measurements given by the author are 70 cm. by 55 cm.

FIG. 137.

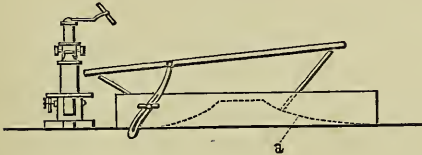

FIG. 138.

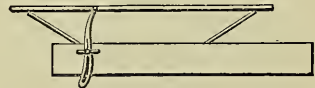
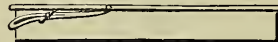

FIG. 139.



If the rackwork arrangement be made to a curve (fig. 137, *a*) the teeth will hold more firmly, but this is not necessary, as the apparatus is perfectly steady.

Babes' Hot Stage.\*—In figs. 140 and 141 are shown different aspects of Dr. V. Babes' hot stage for constant temperatures. By means of the

two screws *sch* it is fastened to the stage of the Microscope or to Reichert's movable stage. The hot stage consists of a gnomon-shaped box filled with water or glycerin. The preparation is slipped in through the aperture *o*, and it can be moved about. It is warmed both from above and below. The objective and the Abbe condenser are partly surrounded by the box. Heat is imparted by a thick copper wire *k* heated in a gas flame. The other end, which is within the box, is convoluted. The copper wire is insulated from the sides of the box by a layer of asbestos.

The regulation is effected by means of an electrical thermometer *T* inserted in the same orifice as that in which the preparation is placed, and consequently exposed to the same temperature. The wires of the electric thermometer pass to the apparatus shown in fig. 140, which is supplied by a small Leclanché battery. By the movement of the pole to a point previously settled upon, the current is closed, and the plate *V* attracted towards the electro-magnets. This reduces the stream of gas at *Z*, and the flame is consequently diminished. As the mercury sinks, the valve *V* is again opened, and the gas again flows through the pipe *Z* to the jet. To the thermostat there is also

FIG. 140.

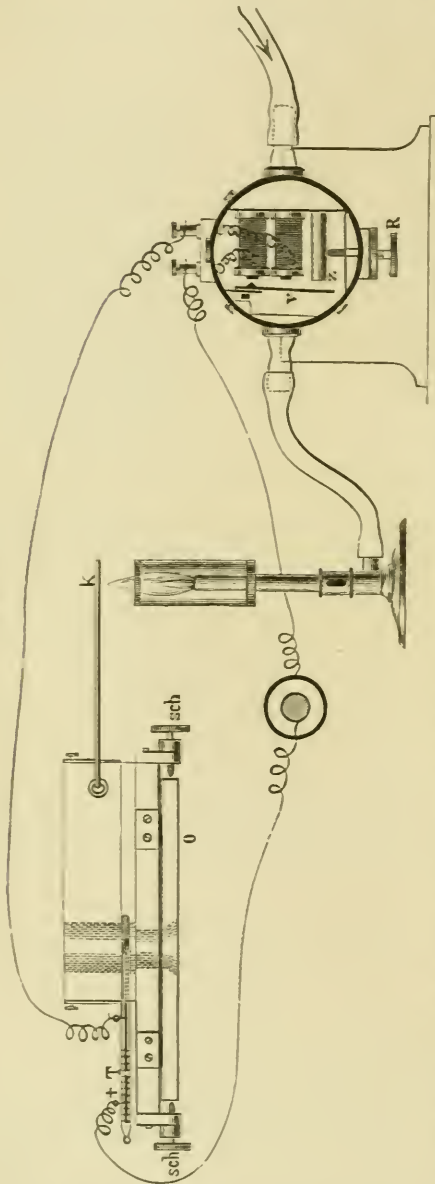

\* *Centralbl. f. Bakteriol. u. Parasitenk.*, iv. (1888) pp. 23-5 (2 figs.).

attached a screw (R, fig. 140) for specially regulating the flame when it has been reduced by the regulation apparatus. As the regulation of the

FIG. 141.

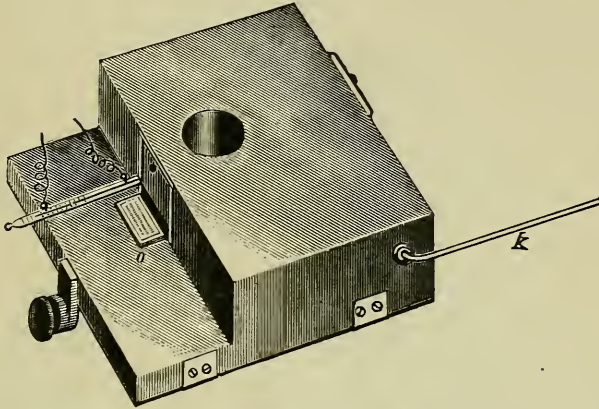

temperature is instantaneous, the vital conditions of bacteria at definite temperatures can be studied exactly.

**Capillary Slide and accessories for the examination of Ova.\***—This apparatus, which was designed by M. L. Chabry for the examination of Ascidian ova, has now received several additions rendering it more serviceable than the original form (see this Journal, 1887, p. 319).

It consists of a thick glass plate *p* (fig. 142) placed on the stage of the Microscope, and upon which rests a capillary tube *T* bent at a right angle, the latter part projecting over the stage. The tube lies in a couple of glass sockets *d d* fixed to the plate with shellac. This allows the capillary tube to be pushed up and down from left to right, and also to turn on its axis. This axial revolution is effected by a special contrivance. *P o* is a metal plate bent at a right angle with a long and a short leg. The longer leg is clamped to the stage by a screw, so that the shorter leg is parallel to the side of the stage and about 5 cm. distant from it. Through the short leg passes the rod *M B*, bent twice at a right angle, and one end of which is fixed on a disc, about the size of a penny piece. *K* is a plate of shellac fastened to the short leg. By turning the disc the capillary tube is made to revolve. The tubes must be perfectly free from air-bubbles, and it is advised to keep a quantity of them on hand. They should be about 10 cm. long and arranged according to the breadth of their lumen, and that tube should be selected of which the diameter is about equal to that of the object to be examined, so that when the tube is made to revolve the ova may not be damaged.

The ova are introduced into the capillary tube by a suction-pump made out of a piece of glass tubing fitted at both ends with a piece of rubber tube. On one piece of the rubber tube is fitted a self-acting clamp, between the clips of which is slipped the capillary tube. To the other piece is fitted a small syringe, by the use of which the ova are sucked

\* Journ. de l'Anat. et de la Physiol., xxiii. (1887) pp. 167-320 (5 pls.). Cf. Zeitschr. f. Wiss. Mikr., v. (1888) pp. 60-5 (2 figs.).

into the tube. This operation may be performed under the Microscope if necessary.

If any other movements are to be imparted to the ovum an additional apparatus is required. This is called the perforator, and consists of a

FIG. 142.

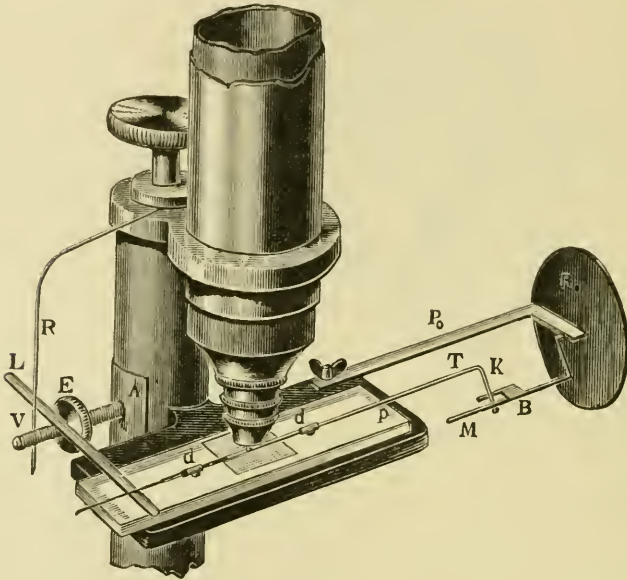

needle, its case, and motor apparatus—a lever controlling screw and spring. The needles are made out of glass by drawing out very fine threads from a glass rod over a lamp. A quantity of these about 10 cm.

FIG. 143.

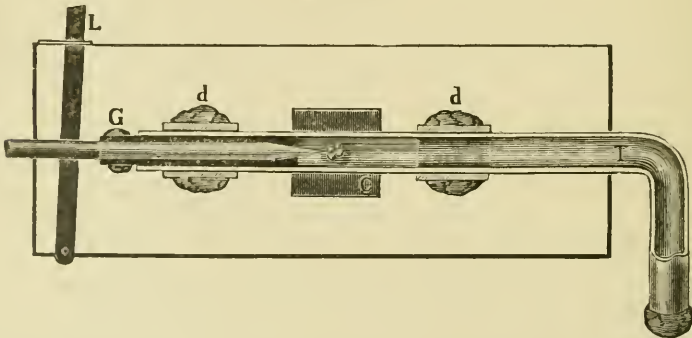

long should be made. Those which are quite regular in thickness are then to be arranged in packets, after inspecting them under the Microscope; the points are then fixed on to capillary tubes by means of a thermo-cautery. This piece of manipulation requires much practice and patience.

In order to introduce a needle into the capillary tube upon the slide, a special protector is necessary. This is shown in fig. 143 where it appears as a black tube fastened to the slide by shellac G. The difference between the parts sliding on one another must not amount to more than  $10\ \mu$ . The lever L, figs. 142 and 143, is fixed to the capillary tube with a minute drop of marine glue. The other extremity lies upon the screw V fixed to the standard of the Microscope at A, and between the milled head E and the spring R, made of brass wire. The perforation of an ovum is effected by just flicking the spring after having turned the screw back to the required degree.

There are numerous minute details given by the author as to points of manipulation, but for these the original must be consulted.

**Measuring Corrosion Surfaces in Iron Pyrites.\***—Herr F. Beeke, while examining iron pyrites, came to the conclusion that the primary corrosion surfaces were those of greatest resistance, and in order to prove this measured the difference between several parallel surfaces on the same crystal. For this purpose a screw micrometer by Zeiss was used in conjunction with an apparatus (shown half its natural size, fig. 144) for measuring the thickness of the crystal under the Microscope. To the metal plate A interrupted at O, the upright piece B is attached, and to this a piece of plate glass E is fixed. Upon A are also fixed two more uprights C D, through which the screws S and F work. The screw S is rounded off at one end, pointed at the other, and bears a milled head. The screw F is pointed at one extremity, and at its other terminates in a milled head. This screw during the experiments is fixed. The crystal K is placed between the glass plate and the screw S, which is made to fix it closely both before and after corrosion. Then the difference in distance between the points S and F shows the amount of substance lost.

FIG. 144.

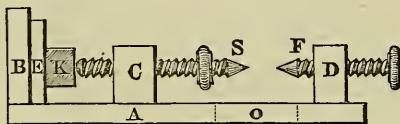

To the metal plate A interrupted at O, the upright piece B is attached, and to this a piece of plate glass E is fixed. Upon A are also fixed two more uprights C D, through which the screws S and F work. The screw S is rounded off at one end, pointed at the other, and bears a milled head. The screw F is pointed at one extremity, and at its other terminates in a milled head. This screw during the experiments is fixed. The crystal K is placed between the glass plate and the screw S, which is made to fix it closely both before and after corrosion. Then the difference in distance between the points S and F shows the amount of substance lost.

**Rowland's Reversible Compressorium.**—This device of Mr. W. Rowland (fig. 145) consists of two thin German silver plates each with a

FIG. 145.

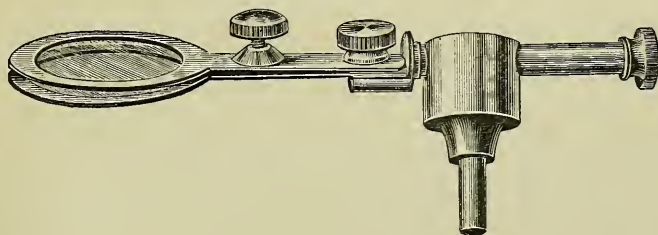

ring having a piece of cover-glass cemented to it. The lower plate is attached to a rod turning in a socket, while the upper pivots on a milled

\* Tschermak's Mineral. u. Petrogr. Mittheil., viii. (1887) p. 318. Cf. Zeitschr. f. Wiss. Mikr., iv. (1887) pp. 411-2 (1 fig.).

head which clamps it if required, or releases it when needed for more easy cleaning. Varying pressures of the cover-glasses are obtained by turning the milled head in the centre of the plate as in Wenham's compressorium. The socket fits in a hole in the stage, in the same way as stage forceps.

**Beaumont's Reservoir Life-slide.**—Mr. C. R. Beaumont describes this (figs. 146 and 147) as follows:—"Having long felt that if a cell were constructed in which minute organisms could be kept alive under as nearly as possible natural conditions, and at the same time allow of fairly high

FIG. 146.

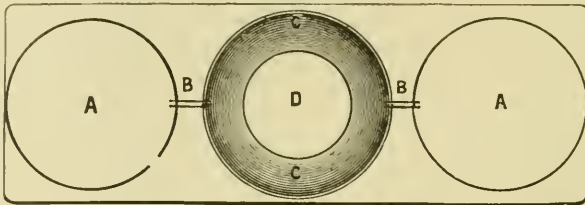

powers being used for their examination, a much more accurate knowledge of the life-history of such organisms would be obtained, I at last conceived the idea of making a slide having reservoirs at each end, in which could be stored a supply of water; and so made that a small current could be continually kept flowing through the cell, from one reservoir to the other, either on or off the Microscope, thereby keeping the organisms in the cell constantly supplied with fresh water, in a manner as near as could be similar to the conditions obtained in their natural habitat.

FIG. 147.

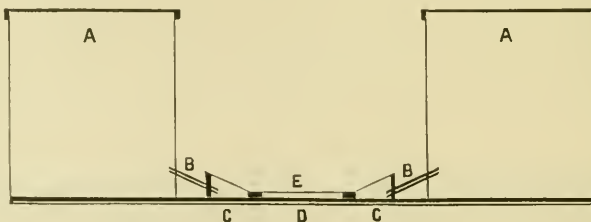

The gentle percolation of water through the life-cell serves the treble purposes of keeping the organisms cool, and supplying them with food and aeration. It is not necessary to remind experienced microscopists that when small organisms are placed with a drop of water in a shallow cell and subjected to the concentrated light and heat from a condenser during protracted observations with the Microscope, very great changes are induced in the environment of the organisms, which very frequently lead to important physiological changes. Assuming these changes to be mainly caused by the concentrated heat from the condenser on so small a quantity of water, the immense advantage of using a slide wherein

fresh water is constantly percolating the cell, and regulating the temperature will be self-evident.

The slide consists of a slip of non-oxidizing metal  $1\frac{3}{8}$  by  $3\frac{1}{4}$  by  $1/8$  in., having a central opening of  $1/2$  in. D, with a disc of glass forming the bottom of the central cell, and fitting flush with the underside of the base, allowing of illumination with a paraboloid. Surrounding the glass on the upper surface is a slightly raised edge of metal forming a central flat cell, having a uniform depth about equal to the thickness of ordinary blotting-paper. Outside this central cell is a slight recess in the metallic base, which forms an annular cell C, surrounding the central one through which water percolates when in use. The central and annular cells are closed by means of a thin cover-glass, cemented to a rim of metal E, which fits water-tight over the two cells; the under surface of the cover-glass being held close against the raised edge of metal forming the boundary of the inner cell, thus closing and preventing the escape of organisms placed therein. There is water communication between the central and annular cells, by a series of very fine capillary lines, ruled in the metallic edge between the cells.

On each end of the metallic base is fixed a reservoir A having a glass cover. These reservoirs are directly connected with the annular cell by fine tubes B, through which water flows when in use from one reservoir to the other.

The action is as follows:—Organisms are placed in the central cell and the cover-glass pressed tightly down; one of the reservoirs is then filled with water and the circulation established. If the slide be now placed on the stage of a Microscope provided with a revolving slide carrier so that the full reservoir is highest, the water will flow through the fine tube to the annular cell; a portion of which will percolate to the inner cell by capillary motion, and thence through the second tube into the other reservoir. When the upper reservoir is empty the motion may be reversed, thus enabling a constant circulation to be kept up during microscopic examination. Each reservoir is provided with a small air-vent, drilled coincidentally through the upper edge of the reservoir and the rim of the cover. These vents may be entirely closed when desirable, by simply turning the covers slightly round so that the holes do not coincide. The flow of water may also be regulated, by placing bristles within the fine tubes leading from the reservoirs to the annular cell.

To continue the water circulation when off the Microscope several methods are available, two of which I will here mention. The method which recommends itself as the simplest, and perhaps gives the best results, consists of a stand or support for carrying the slide and large supply reservoir for containing enough water to last several days. The supply vessel is placed at a higher level than the slide, and a siphon may be used to convey water from this vessel into one of the reservoirs. A suitable siphon is easily made by bending a length of vaccine tube (to be had from most chemists) having a short piece of thread pushed inside the long end to regulate the drip. Another shorter siphon made from the same material is placed in the hole near the top of the other reservoir, to conduct the overflow into a vessel placed beneath. A better arrangement is obtained when the supply cistern is fitted with a miniature water-tap near the bottom, the water being allowed to fall in drops into the first reservoir of the slide, and flow out as before stated.

Another system of keeping up the circulation is by means of an automatic tilter. This apparatus consists of a small balanced table having an oscillating motion on a central axis, and made to carry one or more slides. The slides rest on the table with the reservoirs at right angles to its axis, so that each reservoir may be raised or depressed at intervals of about three hours; this being about the time occupied for the water to flow from one reservoir to the other when properly adjusted. The tilting is obtained from clockwork placed in a box underneath.

The first method has the advantage of simplicity and also of giving a complete change of water, and on that account is perhaps the best for most organisms. I may say that with a slide of this kind I have had the pleasure of watching three generations of *Floccularia* in succession. These organisms are probably amongst the most difficult objects to keep in a small slide on account of their voracious habits."

Mr. Beaumont also informs us that a friend who uses one of the slides without any tilting arrangement, finds that all that is necessary is to lay the slide on a flat surface and remove the cover from one of the reservoirs; this allows free evaporation to take place in the uncovered reservoir, thus setting up a current through the slide. Mr. Beaumont thinks that, on the whole, an arrangement without tilting is preferable, as the organisms are not precipitated against the sides of the cell so much.

**Holman's Current Slide.\***—Dr. Holman says that on his slide *Protococcus* may be kept alive many days; *Amœba* three weeks; and Bacteria for six months. In the minute canal, 1/100 in. wide, and 1/1000 in. deep, between the two concavities with shallow margins in his slide, blood-corpuscles may be caused to flow in either direction, to roll over, or to stand on edge by the warmth of the hands of the operator, brought towards the stage of the Microscope at a distance of about six inches.

**Life Slides.†**—Dr. A. C. Stokes in studying the morphology of minute animal organisms, uses only a shallow shellac cell, with about one-fourth of the ring scraped from both the upper and the lower margins, thus leaving two curved supports for the square cover, one on each side. This gives the inclosed drop with its animal life plenty of air, and facilitates the application of the wet brush at the point where the square cover projects beyond the lateral cell-wall. The secret of success consists in leaving enough of the cement ring to properly support the cover, and to lessen the force of the inflowing water supply, and also in having the cell shallow or deep according as the animals are microscopically small or large. Much depends on the depth of the cell in all cases. A comparatively large Infusorian, a Rotifer, or a *Chætonotus* can be injuriously hampered in its movements and in the proper performance of its functions by a cell of insufficient depth, and a good objective can be greatly hampered in its functions by a cell of too great depth.

The author also proposes the following form:—A small square, cut from glass of any desired thickness, is cemented with Canada balsam to a slip, and surrounded by a thick glass or zinc ring so as to leave a wide space between these parts. On the ring place a ring of wax, and,

\* Journ. New York Micr. Soc., iv. (1888) p. 168.

† The Microscope, vii. (1887) pp. 129-33 (3 figs.).

after the object has been arranged on the central square, cover the whole with a thin circle and cement it fast by running a warm wire around the edge to melt the wax. A small drop of water may be placed in the annular space if desired. The thickness of the slip and square, and the depth of the cell must of course be determined by each worker according to his needs. The secret of success here is, to be sure that the joint between the ring and the slip is air-tight, and to firmly secure the cover, using an abundance of wax.

**Lamps for Microscopical Work.\***—The Editors of 'The Microscope' consider that in the efforts to put before the microscopical public attractive illuminating apparatus, writers seem to have lost sight of the excellencies of the humble hand-lamp. Beginners are thus led to purchase the expensive German student's lamp or some still more costly microscopical lamp. It can safely be asserted that for the general purposes of the working microscopist, a small hand-lamp giving a broad, flat flame (such a lamp as can be bought anywhere for 25 or 30 cents) is superior to any of the expensive lamps made especially for the purpose, and we are convinced from our observation of the methods of many microscopists that this is not realised by many except the experts.

By the size of the flame and the distance of the lamp from the Microscope, the intensity of the light can be readily adapted for any work, from the use of the lowest powers to the examination of histological and biological specimens with the highest immersion lenses. For bacteriological work with the 1/12 in. or 1/18 in. immersion lenses this light is unsurpassed. In the examination of opaque objects this lamp is not so convenient, as it is necessary then to have the source of light at quite an elevation. It is very easy, however, to improvise a stand.

**Tubes for Microspectroscopic Analysis.†**—For microspectroscopic analysis it is necessary to be able to alter the depth of the liquids examined and to know exactly what these depths are. Three forms of tubes answer these requirements. The first is a prismatic tube with the same proportions as that of the author's (M. L. Malassez) first hæmochromometer, so that the glass plates at the end of a length of 10 cm. are 10 mm. apart; consequently at distances, say, of 1, 2, or 3 cm. from the top the thickness of the liquid layer is 1, 2, or 3 mm. A millimetre scale placed along the side of the tube indicates the depths corresponding to different points in the length.

In the two other tubes there is an internal sliding tube ("tube plongeant"). The simpler form consists of a metal tube, 2 to 3 cm. long and 5 mm. in diameter; the lower extremity is closed by a piece of glass, and the upper expands like a basin. This is the tube into which the liquid to be examined is poured and it is placed in the aperture of the Microscope stage where it is held by the expansion at the upper end. The tube which slips into this is made of metal, and is a little longer and narrower than the outer one. Its lower end is closed by a glass, and its upper screws into the Microscope tube in place of the objective. By screwing down the Microscope tube the layer of liquid is thereby diminished. If on the Microscope tube there is a millimetre scale, and

\* The Microscope, viii. (1888) p. 206-7.

† Arch. de Physiol., viii. (1886) pp. 268-71 (1 fig.).

if the milled head of the fine-adjustment be graduated, the thickness of the liquid layer is easily ascertained.

The third tube (fig. 148) is less simple than the foregoing, but it is constructed so that it gives the thickness of the liquid layer at once. It consists of (1) a metal tube, the lower end closed by glass, while the upper end is expanded; (2) of another tube to dip into the former and closed at the lower end by glass. But the latter tube, instead of being screwed to the Microscope, is screwed to an arm, the upright of which is fixed to the edge of the first or outer tube, so that by turning the inner tube round it sinks or rises, and thereby produces a thinner or thicker layer of fluid. The depth of the liquid is measured by means of a millimetre scale marked on one side of the upright. The head of the internal tube almost touches this scale, and hence it is easy to read off the number of millimetres the tube has risen or fallen. This procedure is facilitated for fractions of millimetres by dividing the upper surface of the disc into 10, and each of these divisions into two parts, by which a tenth or twentieth of a millimetre is given.

FIG. 148.

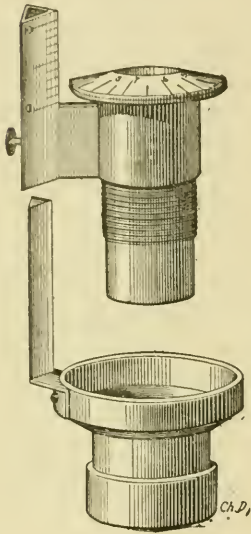

In order that the instrument may be more easily cleaned and fixed at zero, the upright is made in two pieces, the outer being fixed to the inner tube, and the inner one to the outer tube. The two pieces are kept tight by a binding-screw. When a liquid is to be examined, the outer piece is withdrawn, and the milled head of the other turned until

the zeros of the two scales coincide; the tube is then slipped in so that the two glasses at the lower extremities are in apposition. The binding-screw is then tightened up. This position evidently corresponds to the thickness 0.

WEISS, D.—Ueber das Fleisch'sche Härometer. (On the Fleischl Härometer.) *Prager Med. Wochenschr.*, XIII. (1888) p. 20.

#### (4) Photomicrography.

**Burster's Photomicrographic Apparatus.**—Dr. H. Burster's apparatus is shown in fig. 149. The camera A is attached to the wooden stand L R S, the end of the expanding bellows being also fixed to the piece W which carries the Microscope, the stage *m*, and the illuminating apparatus *f c d*. W slides in a slot on R, and may be adjusted to any desired distance from the focusing plate. The various parts of the illuminating apparatus are made to slide upon an iron bar screwed to W, so that they may be adjusted independently.

The whole apparatus is set at any desired inclination by means of the chain K and leg S, and it may be used vertically or horizontally. In the latter case the mirror *f* is removed, and replaced by the source of

\* Jeserich, P., 'Die Mikrophotographie,' Svo, Berlin, 1888, pp. 98-9 (1 fig.).

light. Upon R is a scale which gives the distance of the objective from the focusing plate.

The advantages claimed for the instrument are "the firm stand resting on three points, and the attachment of the whole (illuminating apparatus and camera) to a common stand," "the Microscope, illuminating apparatus, and front part of the camera being capable of being brought to different distances from the focusing plate without the position of the separate parts to each other being in any way changed."

**Neuhauss's Focusing Arrangement.**—Dr. R. Neuhauss uses for the camera described *ante*, p. 294, the mechanism shown in fig. 150.

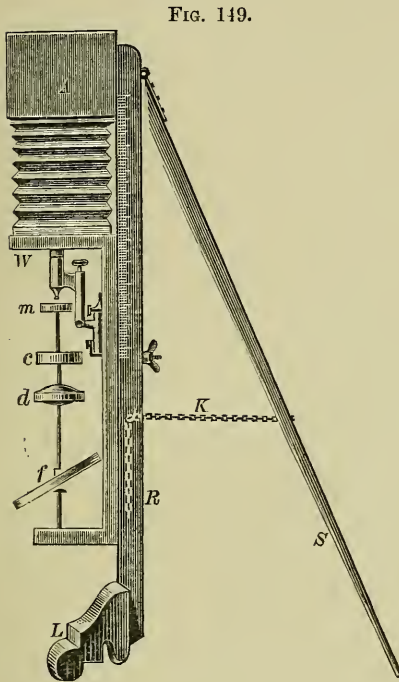

FIG. 149.

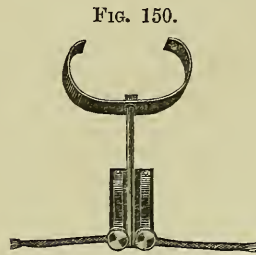

FIG. 150.

A piece of watch-spring is bent as shown in the figure, and is secured to a pin attached to a plate. The Microscope being horizontal, the plate is placed vertically with the ends of the watch-spring engaging in the milling of the micrometer-screw of the fine-adjustment. To the sides of the bottom of the plate cords are attached, which pass over horizontal pulleys on the right and left of the Microscope and are fastened to a wooden rod at the end of the camera. By pulling the one cord or the other the fine-adjustment screw is turned to the left or right.

"In this way" (see p. 294) "the fine-adjustment is made without any inconvenient connecting rods, and can be effected directly by one hand, while the other is engaged with the focusing lens." The motion obtained by the action of the clamp on the micrometer-screw is, it is claimed, quite fine enough to secure the complete sharpness of the image.

**Drawings v. Photographs.**—Screen for the Abbe Camera Lucida.\*—At the present time, when to almost every Microscope a photographic camera is being attached, and when photomicrographs, of every degree of merit, are being produced on all sides, it may be well, Dr. G. A. Piersol considers, to weigh the respective values of the pencil and sunbeam as

\* Amer. Mon. Micr. Journ., ix. (1888) pp. 103-4.

means of recording the observations of the investigator. The idea of reproducing, by photography, what is seen in the Microscope, is so captivating, that it is a matter for little surprise that so many undertake the work. These remarks do not apply to the photographing of preparations for the purpose of producing excellent pictures, but bear upon the merits of the two methods as auxiliaries to the work-table. That the pencil is being unwisely neglected, owing to a too implicit reliance on photography, is an unfortunate present tendency, especially for the young investigator, who loses the training to accurate observation which the conscientious use of the pencil brings. But both the photographic camera and the drawing-prism have their advantages, and the investigator can afford to dispense with neither, as, by their judicious employment—sometimes by their combination—more satisfactory and valuable results are obtained than are possible by any exclusive adherence to either.

An experience in photomicrography, which warrants a full appreciation of its value and capability, has taught that the most serviceable and satisfactory field of photography lies at the extremes of the table of amplification, with very low (20 to 70 diam.), and with very high powers (500 to 1500 diam.). What drawing can equal, in beauty of detail, a really good photograph of a suitable specimen taken with a fine low-power objective? who can draw fibrillæ of striated muscle, a group of bacteria, or a delicately marked diatom in competition with photographs? Excellent pictures are made under ordinary magnifications (200 to 350 diam.), but in the majority of cases there is much less cause for congratulation. Under these circumstances, the conscientiously and skilfully used pencil will produce a more valuable and satisfactory record for the investigator than the camera. The reason that *good* photographs, with very low or very high powers, are so satisfactory is, that under both conditions suitable lenses reproduce *all* the planes of tissue necessary for a serviceable representation of the object; nine times in ten this will not be the case with the pictures demanded of the 1/4 or 1/6. While it is unreasonable to expect the lens to reproduce more than the plane accurately in focus, it is nevertheless true that this physical limitation (reduced to a minimum by the thinnest possible sections) frequently renders photographs, under medium powers, unsatisfactory substitutes for more diagrammatic drawings. At the present time the investigator who depends upon photographs for his illustrations, finds himself confronted by the pertinent question as to the manner in which his pictures shall serve as journal illustrations. That photography, in its applications to book-making, is yet in its infancy, no one doubts; that really beautiful results are already accomplished by the best methods is equally certain; if, therefore, the liberality of the publisher places one of the unexceptional "processes" at his command, the investigator may feel confident. Let him, however, be cautious as to where he places his hopes when economy is consulted, for there is nothing more annoying to the worker himself, or more unfortunate for the cause of photomicrography, than the dissemination of those monstrosities whose harsh black and white masses, devoid of half-tone and detail, are supposed to "reproduce" a really fine negative.

Frequently, however, the use of the photograph is out of the question, and the investigator or the artist must make the necessary substitute; by all means let it be the microscopist himself, for he will then have the guarantee that the feature of the drawing, especially valuable, is

appreciated. Under such circumstances, a combination of the camera and pencil, which the writer has employed since the introduction of the Eastman "bromide paper," may often be found very satisfactory. Selecting the "B" grade, and marking out all undesired parts of the negative, a somewhat under-exposed print is made and developed until the cardinal parts of the picture are visible; this, when dried, yields a black and white sketch which, after being worked over with Indian ink and hard lead-pencil, presents the appearance of an elaborately finished drawing, and, as such, will be satisfactorily copied by the artist on the block or stone. Where details are very simple, the outlines of the photograph are easily transferred to the drawing-paper by means of the interposed sheet of "graphite" or "carbon" paper and the tracing point.

But, after all, for the busy worker the direct sketch on paper is frequently the most convenient and economical. It is to be regretted that the drawing-prisms in use on the Continent are not more generally used among our own microscopists. An experience embracing all the usual forms has resulted in a settling down to the Abbe apparatus as being the most satisfactory, and, due regard to the inclination of the mirror and the warranted size of the sketch being observed, as leaving little to be desired. After a long observation of struggles with the drawing-prisms usually furnished by American and English makers, it is truly refreshing to see with what ease and accuracy complicated contours are followed with this instrument even at the first attempt.

With any form of drawing attachment the nice balance between the illumination of the microscopical image and that of the paper is an all-important condition; having had occasion recently to use the Abbe prism to sketch some 1400 sections, the author found a simple device of great service. This consisted of a light stand supporting a small glass plate ( $10 \times 15$  cm.), two-thirds of which was "matt," being very finely ground, leaving the remaining third as a clear strip extending in the direction of the greatest length of the plate. The section being well lighted and focused, and the paper adjusted for the drawing, the screen should be interposed between the source of illumination and the mirror, when the object becomes illuminated by a soft diffuse light, very favourable for the rapid and accurate sketching of details. Slight lateral movements of the screen by the left hand soon determine its best position. When a doubt arises as to some detail, a movement of the wrist floods the field with light, enabling an exact observation to be made, while a second change restores the mellow illumination so favourable for drawing. All this can be done without moving the eye from the tube or taking the pencil from the paper. The position of the screen between the light and mirror is more effective than when the ground glass is mounted as part of the substage apparatus. Those who have never used this simple contrivance in drawing will find it a material aid in many cases. Its frequent usefulness on other occasions, as a light-moderator for low-power examinations, will insure it a permanent place on the work-table.

**Instantaneous Photomicrography.\***—Herr M. Stenglein, who has been trying to adapt the instantaneous method to photomicrography, recommends a mixture of magnesium, chlorate of potash, and sulphide of antimony, which gives a flash lasting for  $1/50$ – $1/30$  of a second. The

\* Centrabl. f. Bakteriul. u. Parasitenk., iii. (1888) pp. 670-4, 702-7 (1 fig.).

percentage composition is 60 parts (by weight) chlorate of potash, 30 parts magnesium in powder, 10 parts sulphide of antimony. The combustion of this powder is effected in a lantern L, the body of which is a metal tube, closed at one end and provided at the other with a glass plate and a diaphragm, the aperture of which corresponds accurately with the diameter of the illuminating lens. Within the lantern, and on a level with its central point, is a metal plate, upon which the powder and touch-paper are placed. On the left side of the lantern is a slit closed by a shutter; through the slit the touch-paper is lighted. The lantern is further provided with a chimney, bent at an angle and about 5 metres long. The chimney, which fits on the lantern, is not shown in the illustration. About 0.75-1 metre from its end the chimney is fitted with a special apparatus for absorbing the smoke.

The camera is placed vertically and the illuminating lens B horizontally. The preliminary focusing is made with a mineral-oil lamp, afterwards exchanged for the lantern.

For instantaneous photography the sensitiveness of the plate must be known, and to estimate it for this magnesium powder the author has devised a special sensitometer. This consists of a glass plate  $12 \times 15$  cm., divided up into thirty rectangular spaces of  $2 \times 3$  cm. and covered with tissue paper. The spaces are numbered according to the number of layers of paper. This sensitometer is fixed in a copying frame and then inside a pasteboard box open in front. The frame is then placed in a room lighted by a candle and exposed for a certain time. The ordinary developer is used, but *without* the addition of bromide. Then the number on the sensitometer gives the sensitiveness of the plate. The author's results were obtained from stearine candles (eight to the pound), distance 30 cm., exposure one minute, and developing five minutes with the pyrogallie developer; he found that plates 22 and 23 were quite distinct, and that No. 24 was almost as good.

As most objectives differ more or less in their focus, it is obviously advisable to obtain a filter which will permit sharp photographic pictures to be produced by their aid. A mixture of copper nitrate and chromic acid in water allows only 7 per cent. of all spectrum colours to pass through (or diluted 12-14 per cent.). By using this as a light filter in combination with erythrosin the focal differences are quite obviated. As dry plates are not usually obtainable in a condition suitable for the erythrosin emulsion, wet plates are recommended. All operations with these plates must be conducted in a very subdued red light. Mixtures of erythrosin and silver nitrate give precipitates of a silver compound which are very sensitive to yellow light, and act more powerfully in bromide-gelatin than the pure dye. For making this mixture the following formula is given:—25 ccm. erythrosin solution, 1:1000; 1 ccm. silver nitrate solution, 1:80;  $1/2$  ccm. ammonia; 75 ccm. water. The plates are bathed therein for one minute and dried in the dark.

**Photographing moving Microscopic Objects.\***—M. L. Errera proposes to apply to microscopic objects the process already employed for recording each phase of the movement of a horse, &c., more especially the plan adopted by Anschütz in his "Schnellseher," which is fixed in a dark chamber which that author describes as follows: †—"The succes-

\* Bull. Soc. Belg. Micr., xiv. (1887) pp. 32-5.

† Catalogue of the Wiesbaden Exhibition, 1887.

sive images on the glass of the man or animal in movement are fixed on a circular plate turning on its centre, and they are made to pass one after another behind an opening in a large screen in front of the observer. Every time that one of the images reaches the middle of the aperture it is illuminated during the fraction of a second (about 1/10,000) by the discharge of an induction coil through a Geissler tube placed behind the movable disc." The effect is of course the same as that of the zoetrope or "wheel of life."

M. Errera's idea of applying this process to microscopic objects is thus expressed:—

"The details and the mechanism of the movements of microscopic beings are still very imperfectly known. The cells with vibratile cilia, the infusoria, and the zoospores still present a crowd of problems to be resolved. I can hardly think that photography, which has rendered such great services in analysing the leap of man, the flight of the seagull, and the gallop of the horse, could not also be employed with success in the case of fishes, insects, worms, protozoa, algæ, or isolated histological elements. I propose, in conjunction with a skilful photographer, to make some experiments in this direction. The aquarium Microscope of Klönne and Müller, and that of Nacet with several bodies, suitably modified, will probably allow of the instantaneous photography of microscopic movements."

**Photographing Phosphorescent Bacilli by means of their own light.\***—Dr. Fischer has taken good photographs from cultivations of three different phosphorescent bacteria. To do this successfully it is necessary that the cultivation should shed an intense light, the dry plates must be very sensitive, and the exposure long (24–36 hours). The best pictures were obtained from *B. phosphorescens*, the cultivations of which in a dark room at 5°–10° C. gave out their brightest light. In these photograms not only are the colonies seen distinctly and sharply formed, but the outlines of the test-tubes and other vessels are recognizable. A herring illuminated with *B. phosphorescens* took extremely well, the scales showing with perfect distinctness. The head and tail, which were not illuminated, did not appear in the photograph.

Dr. Fischer then went a step farther, and obtained photographs of external objects, e.g. a watch, by the illumination of these phosphorescent colonies in a dark room. Not only could the time be read, but the hands and second-hands were distinctly visible. The illuminant bacteria alluded to are those commented on before in this Journal (*ante*, p. 277)—the "West Indian" and the "endemic" phosphorescent bacilli, and *B. phosphorescens*.

GRAY, W. M.—Photo-micrography.

[Methods used by the author in photomicrography of sections of animal tissues.] *The Microscope*, VIII. (1888) pp. 172–5.

NEUHAUSS, R.—Die Entwicklung der Mikrophotographie in den letzten zwei Jahren mit besonderer Berücksichtigung ihrer Bedeutung für die Lehre von den Mikroorganismen. (The development of Photomicrography in the last two years with special reference to its importance for the theory of micro-organisms.)

*Centrabl. f. Bacteriol. u. Parasitenk.*, IV. (1888) pp. 81–4, 111–6, 233–4.

[Also reply by M. Stenglein, *ibid.*, pp. 282–3.]

RAFTER'S (G. W.) Photomicrographs.

[Commendatory notice of them.] *Amer. Mon. Micr. Journ.*, IX. (1888) p. 113.

\* *Centrabl. f. Bakteriologie u. Parasitenkunde*, iv. (1888) pp. 89–92.

## (5) Microscopical Optics and Manipulation.

Variation in Micrometric Measurements due to different illumination.—Mr. C. Fasoldt sends us the following “Table showing the variation in measurements due to the different applications of light and illuminations.”

“The image of  $\frac{4}{10}$  in. was the object on which these measurements were made, and was ruled on a glass disc of No. 2 covering glass,  $\frac{7}{1000}$  in. in thickness.

“All measurements were taken on one and the same ruling, with the same Microscope, objective, and eye-piece, under the same focus, and having the Microscope in the same position continually, and only changing the mirror and excluding the one light while the other was used.

<i>Unmounted—Lamplight.</i>			
Lines downward.		Lines upward.	
Concave mirror	4/10 in.	10/100,000 -	Concave mirror
Plane	4/10 in.	5/100,000 +	Plane
Ill. through objective	4/10 in.	5/100,000 +	Ill. through objective
			4/10 in. 10/100,000 +
			4/10 in. 14/100,000 +
			4/10 in. 15/100,000 +
<i>Mounted on Glass.</i>			
Lamplight.		Daylight.	
Concave mirror	4/10 in.	0	Concave mirror
Plane	4/10 in.	15/100,000 +	Plane
Ill. through objective	4/10 in.	31/100,000 +	Ill. through objective
			4/10 in. 30/100,000 +
			4/10 in. 20/100,000 +

“A number of comparisons were made at each position and in the same temperature.

“A Spencer objective was used for these measurements; but Bausch and Lomb and Gundlach objectives were also tried, obtaining the same results.

“The Microscope used is one constructed on my late patents, and has a micrometer for measuring similar to a cobweb micrometer. But instead of cobwebs, three movable steel pointers are used, which are worked as fine as this metal will permit. The stage is mechanical, and the main slide is moved with great precision by a fine screw 100 threads per inch.”

Error was therefore eliminated in the case only of the lines mounted on glass when the concave mirror and lamplight was used.

Testing Screw-Micrometers of Reading-Microscopes.\*—Prof. Reihertz points out that every micrometer is liable to special errors and that these must be studied before the requisite corrections can be applied. The errors are due to (1) the screw itself; (2) the mounting of the screw; (3) the remaining parts of the micrometer.

(1) According as the screw produces unequal linear movements at different parts for a complete turn, or unequal linear movements for equal fractions of a single turn, the errors may be called “progressive” or “periodic”; the former are due to inequalities of pitch, the latter to irregularities of the thread.

(2) The position of the screw is fixed by its point or head being maintained in constant pressure against a plane surface; if this surface

\* Central-Ztg. f. Optik u. Mech., ix. (1888) pp. 37-40.

has inequalities, or is not perpendicular to the screw, or if the screw-point is out of centre, the errors in the readings are functions of corresponding fractions of a single turn, or are "periodic."

(3) Imperfections in the other parts may introduce numerous irregular errors, capable of entirely destroying the advantages of metric reading.

The errors may therefore be either progressive, periodic, or irregular; the first may practically be neglected since only one or two or at the most five turns are employed in theodolite readings; the irregular errors must be determined and eliminated by repeated readjustment to the same graduation mark, the vernier being clamped, and by observing the mean errors of adjustment and reading; if these are subject to occasional large variation they indicate imperfections in the mechanism, lubricant, &c.

It remains to determine the periodic errors; i. e. to compare the different values found for the same interval on the scale as measured at different parts of the drum. The most convenient interval to use is the distance on the scale between some graduation and a supplementary mark which corresponds to  $1/10$ ,  $1/8$ , or  $1/5$  of a complete turn. The drum is set to 0, one end of the interval is brought on to the cross wires by the vernier screw, and then the other end by a movement of the drum; the first position is then recovered by a movement of the vernier-screw; and in this way a series of measurements are made by alternate use of the vernier-screw and drum until the zero-reading upon the latter is again reached; the readings are then reversed. A series of such double sets of observations will give a mean value of the interval which may be regarded as the true value, and the differences between this and the values obtained at different parts of the drum will be the corrections to be applied. An example quoted by Prof. Reinhertz shows how the periodic error was determined on a micrometer screw, so that by applying the correction the mean error of a single measurement could be reduced from 8.5 in. to 4.4 in.; and was finally removed altogether by correcting the eccentricity of the hollow cone in which the screw point was made to work.

If the periodic errors do not lie within the mean errors of adjustment and reading the screw should be rejected, and in any case the periodic errors should be eliminated by repeated readings at different parts of the drum.

**Arachnoidiscus as a new Test for High-power Objectives.\***—Mr. T. F. Smith says that there are two great objections to using the Podura scale as a test object for an oil-immersion. The first is that the conventional markings can only be seen when the scale is a little way off the cover-glass, and, consequently, the objective not working at its full aperture; and, secondly, it is impossible to tell the best point.

A dry glass, on the Podura scale, is exceeding sensitive, and a little turn of the correction-collar, or a little difference in the length of the draw-tube, will make all the difference between fine definition and no definition at all. With the oil-immersion, however, you can go through the whole range of the correction-collar without making any difference in the markings, beyond changing them from red to blue. Of course,

\* Journ. Quek. Micr. Club, iii. (1888) pp. 247-53.

opticians will tell you that they know the best point, but his experience is as follows:—

Four object-glasses, with a correction-collar, were supposed to be set with best definition on the Podura scale at the point 0; the first was best on a balsam-mounted slide at point  $2\frac{1}{2}$ ; No. 2 glass was at its best at point 5; No. 3 at point  $7\frac{1}{2}$ ; and the last glass at its best on the same slide at point 10, or as far as it could go. It is no use blaming opticians, for the English microscopists have been brought up (and rightly, up to a certain point) to believe in the Podura scale, and makers cannot be expected to run the risk of producing a glass that is not at its best on that test. The only way then is to offer a substitute that shall stand for the oil-immersion in the same relation as the Podura scale does to the dry glass, and for that purpose Mr. Smith “offers the outer plate of the *Arachnoidiscus* (anything) mounted in balsam.”

To him there is a particular appropriateness in choosing this as a test object, from the fact that although its main features for the last forty years have been as well known as the Podura scale itself, the discovery of the finer markings or structure is due entirely to the oil-immersion objective.

The advantages claimed for the new test-object for an oil-immersion are that the little projecting points or spines can only be clearly defined where the objective is perfectly corrected and set at its best point.

It is not every disc of the diatom that will act as a test, any more than will every scale of Podura. Some will show no projecting spines even with the widest-angled objective, and others are so coarse as to be no test at all; but a properly selected one will answer all the purpose, both for defining and resolving power.

**Tests for Modern Objectives.\***—Mr. E. M. Nelson considers that the advance of the Microscope in recent years is due to the *Podura* scale and the following diatoms:—1st, *Rhomboides*; 2ndly, *Grammatophora subtilissima*; 3rdly, and probably to a greater extent, *Amphipleura pellucida*; lastly, and at the present time, to *Pleurosigma angulatum*, *N. rhomboides*, and the secondary markings of diatoms in general with large angled cones of central light. It was the demand for glasses that would give classical images of the *Podura* scale which improved the central portions of the objectives, and it was the demand for diatom-resolving lenses which spurred on the opticians to make wide angles and to correct the margins.

But however much we may regret it, these old tests—the *Podura* and the *Amphipleura pellucida*—which have been of great service to the cause of microscopy, must be laid aside. The classical picture of *Podura* demands such a very small area of the centre of an objective that it tests too little of the glass.

The following are a few tests for modern objectives:—

1. *Pleurosigma angulatum*, showing dark perforations on a light ground, with a fracture passing through them. While the dioptric beam passes though the centre of the lens the diffraction spectra sweep the margin. Unless a lens be truly centered it will not stand this test.

2. A Cherryfield *Rhomboides* in balsam or styrax with the full aperture of Powell's latest condenser is a very severe test.

\* Engl. Mech., xlviii. (1888) p. 51.

3. To these may be added the secondary marking on diatoms, e. g. *Coscinodiscus asteromphalus*, &c.

4. The fracture passing through the secondary markings, such as (a) *Triceratium*, (b) *Isthmia nervosa*.

5. The secondary markings in the areolations on the hoop of *Isthmia nervosa* in balsam.

All these tests are intended for solid cones of direct light of various apertures. Two classes of tests are comprised in this list. The first, and perhaps the best, is the way a fairly large test is presented. 1, 2, 4 (a), and some of 3 are in this class.

The other class consists in the possibility of making out the test at all. 4 (b), 5, and some of 3 are in this class.

**Fasoldt's Test-plates.\***—Mr. C. Fasoldt replies to Dr. R. H. Ward's report on the examination of one of his test-plates. He claims that Dr. T. F. C. Van Allen "resolved every band up to and including the 200,000 lines per inch in the presence of Dr. Ward." Also that "a number of gentlemen" have resolved all bands up to and including the 200,000, "seeing plainly lines and spaces."

"The successful resolution of the lines is not dependent on the mode of ruling, but on the eyes. And, considering the admitted inability in Dr. Ward's eyes, it would seem no more than an act of justice to all concerned had the Doctor delegated his position on the committee to some one whose eyes were more reliable, and who would have been equally unprejudiced as himself in making the investigations. Good eyesight is certainly an essential factor in such close tests as the resolution of even 120,000 lines per inch, and there may perhaps be a reasonable doubt whether the Doctor was able to resolve the 120,000 lines per inch, as he claimed he was able to do. His admissions are, however, very candid, and his report can, therefore, have no value as to the number or resolvability of the rulings under discussion."

**Microscopical Optics and the Quekett Club Journal.**—When an esteemed friend goes astray it is often very perplexing to know what course to take. Are we to leave him unadmonished out of fear of impairing the ties of friendship, or are we to openly recognize the evil of his ways and act accordingly? The friend who has more especially brought this difficulty to mind at the present moment is the Quekett Microscopical Club, for which we retain unimpaired all the regard of early days, and the evil in this case relates to some papers printed in its Journal.

We recently had occasion to comment upon some comical blunders occurring in a paper in which optical principles were turned upside down in a very naïve manner, but the last part of the Journal goes beyond even that extraordinary paper, and we find page after page containing the most terrible nonsense that has ever been published hitherto in a microscopical journal. The paper to which we more particularly refer is one entitled "On True and False Images in Microscopy,"† the writer of which, as he shows in paragraph after paragraph, has not taken the trouble to master even the rudiments of the subject about which he writes, although he starts with the ludicrous statement that, "to him the subject presents no difficulty whatever"! One of the more strik-

\* The Microscope, viii. (1888) pp. 220-3.

† Journ. Quek. Micr. Club, iii. (1888) pp. 267-72.

ing instances of this will be found in the author's statement (p. 268) that a passage quoted from Prof. Abbe "clearly means that, given perfect "correction of the objective, there is perfect definition of the object, *which to me seems to contradict the former part of the paper.*" The writer therefore has avowedly not a glimmering of a notion of that most elementary point of the diffraction theory—the difference between, "delineation" and "definition," or that perfect definition is quite consistent with imperfect delineation.

If the only result of publishing the paper were to raise a laugh at the expense of the author, the matter might be treated as not being of more than personal interest, but when we find the Quekett Club printing such rubbish, it is necessary to make a protest in the interest of microscopical science against so retrograde a proceeding, and this the more so as it was at the Quekett Club that one of the earliest demonstrations was given of the fact that microscopic images cannot be interpreted by simply "believing the evidence of one's own eyes," as it is now suggested is all that is necessary.

In another part of the same No. we have a bewildering mixture of conflicting statements.\* As will be seen from the extracts we print below, the speaker declares as "absurd on the face of it, and Prof. Abbe did not believe anything of the kind," just what Prof. Abbe, as appears from another part of the same Journal, does believe, and which is nothing less than the cardinal fact of the diffraction theory, while the speaker himself later on, apparently quite unconscious of the discrepancy, states his belief in the very thing which he had before denounced as absurd.

*Speaker's first Statement.*

"There had no doubt  
"been some very objec-  
"tionable passages written  
"in connection with the  
"subject—not perhaps by  
"Prof. Abbe, but in such  
"a way as to appear to  
"put them into Prof.  
"Abbe's mouth; such for  
"instance, as the state-  
"ment that because the  
"whole of the diffraction  
"images were not taken  
"in, therefore the whole  
"structure of the object  
"could not be known.  
"That, of course, was  
"absurd on the face of it,  
"and Prof. Abbe did not  
"believe anything of the  
"kind."

*Prof. Abbe's own Statement.*

"Perfect similarity be-  
"tween the microscopical  
"image and the object  
"always depends on the  
"admission to and utiliza-  
"tion by the objective of  
"the whole of the dif-  
"fracted rays which the  
"structure is competent to  
"emit. When a portion  
"only of the total diffrac-  
"tion fan appertaining to  
"a given structure is lost,  
"the image is more or less  
"incomplete or dissimilar."

*Speaker's second Statement.*

"With these difficult  
"objects, however, though  
"they could get a fair  
"knowledge of them with-  
"in the limits of their  
"optical power, yet they  
"came at length to a point  
"where the largeness of  
"the angle required was  
"such that they could not  
"yet grasp the diffraction  
"spectra, and at that point  
"their entire knowledge  
"necessarily ended."

The mischief of all this is that it must necessarily have the effect of making a student believe that the subject is so confused and unsettled that it is of no use to try and understand it.

There is plenty of room for most interesting criticism on the subject of diffraction, but to be worth printing it must be founded on intelligent doubt, and must not consist of raw and undigested ideas arising from simple ignorance of the subject, which renders it necessary to win over

\* Journ. Quek. Micr. Club, iii. (1888) p. 288.

again (for some minds) the ground formerly won and now so inconsiderately put in peril of being lost.

HARCHEK, A.—Optometer und Apparat zum Messen der Brennweiten und zum Centriren optischer Linsen, System North Harchek. (Optometer and apparatus for measuring the foci of and centering optical lenses,—North Harchek's system.)

*Breslauer Aertztl. Zeitschr.*, XII. (1888) p. 139.

**Highest Magnifying Power.**

[Another specimen of the general ignorance on this subject. "What is the highest magnifying power that has been obtained? In 1864 an eminent microscopist expressed his opinion that in object-glasses with one twenty-fifth of an inch focus the Microscope had reached its utmost attainable limit of perfection. He added that it appeared impossible to separate or define lines more numerous than 90,000 in an inch on account of the decomposition of light. Yet within a few years after this opinion had been expressed, an object-glass with a one-fiftieth of an inch focus was made which magnified 1,575,000,000 times. This revealed the one four hundred thousandth part of an inch; but it again has been left far behind by a glass recently made in Sweden, which enables us to distinguish the one two hundred and four million seven hundred thousandth part of an inch."]

*Tit-Bits*, XIV. (1888) p. 310.

MERGIER, G. E.—*Traité pratique de Manipulations de Physique à l'usage des Etudiants en Médecine, précédé d'une Préface par M. le Prof. C. M. Gariel. Optique.* (Practical treatise on physical manipulations for students in medicine. With a preface by Prof. C. M. Gariel. Optics.)

iv. and 251 pp. and 90 figs., 8vo, Paris, 1888.

NELSON, E. M.—On the Interpretation of a Photomicrographic Phenomenon by the Abbe Diffraction Theory. *Journ. Quek. Micr. Club*, III. (1888) pp. 273-9.

" " True and False Images in Microscopy.

*Journ. Quek. Micr. Club*, III. (1888) p. 288.

" " *Amphipleura pellucida.*

[Report of resolution with Powell's 1/4 in. objective 1.17 N.A. with dry front, i. e. with 1.0 N.A.]

*Engl. Mech.*, XLIII. (1888) p. 51.

SMITH, T. F.—On True versus False Images in Microscopy.

*Journ. Quek. Micr. Club*, III. (1888) pp. 267-72, 288-9.

TANAKADATE, A.—Note on the Constants of a Lens.

*Journ. Coll. of Sci. Tokio*, I. (1888) p. 333.

VEREKER, J. G. P.—Numerical Aperture.

*Journ. of Micr.*, I. (1888) pp. 155-66 (4 figs.).

(6) Miscellaneous.

Simple method of Projecting upon the screen Microscopic Rock Sections, both by ordinary and by polarized light.\*—Mr. E. P. Quinn "knowing the difficulty experienced in pointing out to students any particular crystal in a rock section when viewed with the Microscope direct, attempted to project the images on the screen, and by the aid of comparatively simple apparatus met with very gratifying success, both with ordinary and with polarized light.

The tube of the Microscope was screwed out and replaced with a cork, through which a hole had been cut to carry the ordinary 1 in. objective, and behind it the analyser of the Microscope. The polariscope and rock section occupied their usual position as when used with the Microscope in the ordinary way. The Microscope-stand being inclined into the horizontal position was placed in front of the object-lens of the limelight lantern. The object-lens of a lantern usually consists of a combination of two lenses. If so the back lens is taken out and the front lens only used, acting as an extra condenser, concentrating the light upon the rock section and causing it to pass through the polarizer and the analyser.

\* Rep. Brit. Assoc. Adv. Sci., 1887, p. 725.

A little adjustment of the light was required to get it well through both polarizer and analyser, but this with a little care was soon done, and a bright picture, several feet in diameter, was projected upon the screen, showing the crystals well defined and exhibiting very strikingly the changes of colour, &c., characteristic of the crystals when viewed by polarized light, and in such a manner as to be well seen by a number of people at once and also allowing the lecturer to readily point out any particular crystal or crystals to which he desires to draw the attention of his audience. As the optical axis of the lantern and Microscope did not coincide, the lantern was placed on a board provided with four levelling screws, with which the necessary adjustments were readily made.

Much better effects may be got if the 'Prazmowski' form of prisms made by Zeiss are used instead of the usual Nicol's prism on account of their greater aperture and shorter length, and the most brilliant results with the 1 in. objective of fifty angular apertures (*sic*) by Wray of London."

**Microscopy and the Study of Rocks.\***—Prof. J. W. Judd thinks there is perhaps just now a danger of our exaggerating the importance of the microscopic method as applied to the study of rocks. That the method has already done much in enabling us to follow out and trace the effects of the slow processes of change within the earth's crust, and that it will do still more in the future no one can doubt. But when it is sought to make the Microscope a "court of final appeal" in geological questions, and in doing so to disregard the importance of field observation, we perceive the same source of danger as is now perhaps being experienced in connection with almost every branch of natural history research. It must be remembered that while the Microscope enables us to see a little more than the naked eye or the pocket lens, yet, nevertheless, between what is actually seen by the very highest powers of our Microscopes and the molecular groupings and reactions which give rise to the varied phenomena of the mineral kingdom, there is room for almost infinite possibilities. We accept the teaching of the Microscope with all thankfulness, but we recognize the fact at the same time that it has enabled us to get only a very little nearer to the heart of those great physical problems which we aim at solving.

**Microscope and Telescope.†**—M. J. C. Houzeau, formerly Director of the Brussels Observatory, has a lengthy paper under this title, from which we extract the following:—

"The field of scientific research was immensely widened by the simultaneous invention of the Microscope and Telescope. In the whole course of history there is not another invention which has exerted a similar influence in the sphere of material facts. The circle of individual action was extended in an unexpected degree by gunpowder; it was this which enabled Cortez and his four hundred followers to put to flight armies which outnumbered his own in the proportion of 100 to 1. In the strictly material order of things, gunpowder is the first signal triumph of applied science—of modern science. But we must grant that it had an essentially destructive character; it belonged to the arts of war, which in our social childhood take precedence of the arts of peace.

The second invention which—still in the material world—produced a profound revolution, belonged to the useful arts. This was the steam engine, by which our industrial forces have been enlarged to an enor-

\* Nature, xxxviii. (1888) p. 336.

† Bull. Soc. Belg. Micr., xiii. (1887) pp. 90-110.

mous extent; it constituted an addition of energy which was equivalent to the creation of millions of workmen. The steam engines at work in civilised countries represent the labour of ten or twelve times the total number of adult males in the population of the world. This was an acquisition of power, but not of intelligence.

But after these two inventions, the one warlike, the other industrial, there came one belonging to science, that of the Microscope and Telescope, which has had no parallel in history for the extent and the effects of its material results. Outside the world as perceptible by our senses, there was, above and below, a sort of immense envelope, which had for thousands of years escaped the eyes of man. Beyond the boundaries of the visible, both in the large and the little, there was, as it were, a second sphere, vaster than that in which so many generations had lived, which had remained up to that time an impenetrable domain. One day, thanks to what I shall call the new eyes with which man learnt to endow himself, the previously unknown world was revealed to us; and we know now whether it contained sufficient subjects of interest and wonder.

Viewed thus in its glory, the double invention of the Microscope and the Telescope appears a sudden thing. Yet this great and extraordinary extension of the sense of sight was not altogether new. Primitive man could not remain a stranger to certain facts of magnification which, so to speak, forced themselves upon his attention.

When I was living in the Antilles, I once saw a black, who had been brought from his native land of Africa before the suppression of slavery, and who was consequently a savage, looking through a drop of dew at a gnat upon a leaf. This was a temporary observation, unintentional and the effect of chance; still it was none the less an observation, and the chance would naturally recur in certain circumstances. Primitive man could not then be entirely ignorant of the magnifying power of drops of water. . . .

The two instruments, the Microscope and Telescope, thus appear to us as proceeding from the same germ. We see that they were produced at the same time, the beginning of that 17th century to which they were destined to reveal so many marvels, and in the same form, namely a convex lens associated with a concave lens. The first improvement was made contemporaneously in both, by the substitution in both cases of a convex for a concave eye-piece; for the Telescope in 1613 by Scheiner at the suggestion of Kepler, for the Microscope in 1618 by Francesco Fontana. Both profited, so to speak, by Huyghens' idea of using three lenses, and both were at the same time invested with a new power by the application of achromatism. There is a further resemblance; the names of the two instruments remained vague and to some extent confused; the Academy dei Lincei, at Rome, judged it necessary to have distinct names, and a Greek, named Remiscianus, settled in Italy, supplied the two words Microscope and Telescope; so that the two instruments born together received baptism at the same time, after having shared everything at their entrance into the world.

If they have subsequently separated, and if they tend to separate more widely in their construction, it is only in consequence of the different purposes to which they are applied. Practical convenience has led by degrees to distinct arrangements adapted on both sides to the conditions which they have to satisfy. But this diverging course should not make us forget the original similarity of the types. . . .

The invention of the Microscope and Telescope has not only contributed to open out a new sphere to us so vast that we cannot yet realize its extent, but it has also shown us the contrast which exists between our mental faculties and the fertility of nature; we have here an evident proof that the imagination, however potent it may at first appear, is only rich in combinations of known things; it forms combinations of great variety, often fantastic and unnatural; it can magnify or reduce images to any extent; but from its own source it extracts nothing that is really new; and however inventive it may imagine itself to be, it would discover nothing if nature did not supply examples."

#### Brain Markings.

["A well-known New York physician has just published the sort of discovery which Lord Lytton would have made a novel out of. An aged Polish count, formerly professor of languages and a famous oriental scholar, died in the hospital, and Dr. Rookwood had occasion, in conjunction with other experts, to make a microscopical examination of a certain part of the cerebrum. They noticed a peculiar set of markings, which took the form of Egyptian and Chinese hieroglyphics. These were amplified to a magnitude of 3000 diameters, and the results shown to another oriental scholar, who declared them to be true characters in the Ethiopic, Syriac, and Egyptian languages. Dr. Rookwood suggests that his discovery will lead to extracting from the dead their literary achievements as well as their suppressed opinions."]

*Sci.-Gossip*, 1888, p. 67.

#### Conservirung von Zeichnungen. (Preserving drawings.)

[Lay the drawing on a flat surface and pour over it collodion in which 2 per cent. of stearine has been dissolved. In twenty minutes it is dry and fixed.]

*Neueste Erfind. u. Erfahr.*, 1887, p. 571.

#### DALLINGER, Rev. W. H.—Memoir.

*Research*, I. (1888) pp. 40-1 (portrait).

#### Dallinger, Dr., Presentation to.

["'All Sheffield,' of any public note, took its leave of Dr. and Mrs. Dallinger in the Council Chamber of the cutlery metropolis on Tuesday. The Mayor, on behalf of numerous subscribers, presented Mrs. Dallinger with a silver tray, and the Dr. with a substantial sum of money, the value of the gifts being enhanced by the kindest expressions of regard for the recipients. The Mayor regarded Dr. Dallinger's removal from the town almost as a public calamity. The Doctor said that since he came to Sheffield he had been privileged with companionship and friendships and intercourse which had made his life, that was full of labour, equally full of sweetness. His labour during the past eight years had not been barren; some work had been accomplished. He had been enabled, by increasingly powerful instruments, to penetrate still further and further down, but so far as this portion of his life had been serviceable to science, it had been more powerful than it otherwise could have been because he was surrounded by such friends and such interests in this never-to-be-forgotten town. He thanked them for the present to his wife, without whose constant assistance he could never have performed the work that had been done at Wesley College. The gift to himself would be devoted to the purchase of any new instrument that he required, so long as it lasted. He had been working in a department of science that had been absolutely untouched, and he was constantly finding that something was wanting that was not existing in scientific instruments before. It was a source of joy to him that through its gift Sheffield would be permanently represented on the scientific side of his house."]

*Christian World*, Aug. 16, 1888.

#### FRITSCH, G.—See Neumayer, G., *infra*.

#### Gosse, P. H., Hon. F.R.M.S.—Obituary.

*Athenæum*, 1888, Sept. 1, pp. 294-5.

#### Gray, Asa, Hon. F.R.M.S.—Obituary.

*Nature*, XXXVII. (1888) pp. 375-7.

#### [MANTON W. P., and OTHERS.—Use and Abuse of the Microscope.]

["Dr. E. L. Nealey, of Bangor, read a paper on the 'Use and Abuse of the Microscope' before the recent meeting of the Maine Medical Society. Our experience leads us to think that most physicians abuse the instrument by not using it."]

*The Microscope*, VIII. (1886) p. 217.

NEUMAYER, G.—*Anleitung zu wissenschaftlichen Beobachtungen auf Reisen.* (Guide to scientific observations in travelling.) Contains Fritsch, G., *Praktische Gesichtspunkte für die Verwendung zweier dem Reisenden wichtigen technischen Hilfsmittel: Das Mikroskop und der photographische Apparat.* (Practical suggestions for the use of two of the traveller's important technical aids: the Microscope and the photographic apparatus, pp. 512–612, 8 figs.)  
2nd ed., 2 vols. 8vo, Berlin, 1888.

RUTLEY, F.—*Rock-forming Minerals.*

[Contains chapters on (1) Apparatus, Methods of Preparation, Examination, &c., (2) Propagation of Light, Reflection, Refraction, Double Refraction, Optic Axes, &c., (3) Polarization of Light, (4) Axes of Optical Elasticity, Examination in Polarized Light, (5) Wave Surfaces, (6) Bisectrices and Optic Normal, (7) Examination in Convergent Polarized Light, (8) Pleochroism.]  
iv. and 252 pp., 126 figs., 8vo, London, 1888.

VEREKER, J. G. P.—[On the Choice of a Microscope.]

*Scientif. Enquirer*, III. (1888) pp. 152–4.

Wiesbaden, *Katalog zur wissenschaftlichen Ausstellung der 60. Versammlung deutscher Naturforscher und Aerzte zu.* (Catalogue of the Scientific Exhibition of the 60th Meeting of German Naturalists and Physicians at Wiesbaden.) Edited by L. Dreyfus.

ix. and 224 pp., 8vo, Wiesbaden, 1887.

Cf. also *Zeitschr. f. Instrumentenk.*, VII. (1887) pp. 428–9.

*Zeitschr. f. Wiss. Mikr.*, IV. (1887) pp. 303–25 (1 fig.).

### β. Technique.\*

#### (1) Collecting Objects, including Culture Processes.

Cultivation of Schizomycetes in Coloured Nutritive Media.†—Herr Birch-Hirschfeld found three years ago that the comma bacilli of cholera not only retained their lively movements in stained bouillon, but multiplied in a manner similar to what they do in unstained hanging drops. It was afterwards found that other kinds of bacteria, both mobile and immobile varieties, behaved in a similar manner, and this method of staining Schizomycetes was then used by the author for demonstration purposes. Besides fuchsin, other anilin pigments were employed (dahlia, Victoria blue, &c.) For the observation of fission fungi in hanging drops, this method offers decided advantages, as the small and motile forms are more easily found and focused, and the morphological characters of the bacteria are also rendered more evident by the staining of their protoplasm.

The author remarks that bacteriological literature scarcely notices the relation of living bacteria towards anilin pigments, and seems to think that such a method might afford information about the morphological changes bacteria undergo in their development and multiplication, and that inoculation experiments with living stained pathogenic bacteria might help to decide certain questions anent the localization and spread of germs imported into the organism. With regard to these points, it may be mentioned that anthrax bacilli deeply stained with diamond-fuchsin or victoria-blue, and grown on gelatin, retain their virulence quite unchanged.

For observing the morphological changes connected with growth

\* This subdivision contains (1) Collecting Objects, including Culture Processes; (2) Preparing Objects; (3) Cutting, including Imbedding and Microtomes; (4) Staining and Injecting; (5) Mounting, including slides, preservative fluids, &c.; (6) Miscellaneous.

† *Arch. f. Hygiene*, vii. pp. 341–53. *Centralbl. f. Bakteriol. u. Parasitenk.*, iii. (1888) pp. 447–9.

and spore-formation, the dyes previously mentioned are of little value, but phloxin-red may be employed with advantage. It is extremely soluble in water, stains spores quite intensely, and cultivations on gelatin and bouillon stained with this dye thrive luxuriantly. Experiments on typhoid bacillus made by this method confirmed the formation of spores as first stated by Gaffky. Benzo-purpurin was also found to be a useful dye, as it stained the spores alone, and left the rest of the protoplasm uncoloured.

**Cultivation of Anaerobic Micro-organisms.\***—Dr. C. Fränkel has invented an apparatus for the cultivation of anaerobic microbes, which he says combines the advantages of the methods of Liborius and Gruber. The nutrient media, bouillon, gelatin, agar, are placed in test-tubes somewhat wider than the ordinary ones. Sterilization, inoculation, &c., are then performed in the usual way. This done, the tube is closed with a caoutchouc plug, through which pass two glass tubes bent at a right angle. One of these reaches to the bottom of the test-tube, the shorter one goes no farther than the bottom of the caoutchouc plug. The exposed extremities are drawn out to fine points, and this arm of the longer tube, besides containing a plug of cotton-wool, is connected with a hydrogen apparatus by means of a piece of rubber tubing. The gas then passes through the nutrient medium and escapes through the shorter leg. When the air is thoroughly expelled, the pointed ends are melted up, and then the medium is spread over the surface of the test-tube in the manner proposed by Ehrlich.

In order to prevent certain sources of error, two points must be rigorously observed; first, the two pieces of glass tubing and the rubber plug must be thoroughly sterilized. This is best done by laying them for an hour in a 1 per cent. sublimate solution. The second source of error is the escape of the hydrogen and the entrance of air. This is avoided by covering the plug with paraffin which melts at about 80°.

When bouillon is the medium, the test-tube can be freed from every trace of air in  $1\frac{1}{2}$ –2 minutes.

If gelatin be used, then the test-tube must be placed in water at 37° while the gas is passing through. This takes only 3–4 minutes. Agar must be used in 2 per cent. solution to which 1 per cent. grape sugar is added. As the agar solidifies rapidly below 40°, it is necessary to be quick in passing the gas through and wetting off the points. The tube must then be rolled round in lukewarm water or in the hand.

The advantages claimed for this method are cheapness, convenience, and suitability for its intended purpose.

**Bacterial Growth between 50° and 70° C.†**—Dr. Globig who has been experimenting with Bacteria found in garden mould, made his preliminary isolation in covered capsules of 5–7 cm. diameter, and grew the micro-organisms on pieces of potato. The colonies thus obtained were cultivated in test-tubes on blocks of potato cut obliquely. For the latter step, potatoes were boiled and disinfected with sublimate solution, and then cylindrical blocks punched out of them with a cork-borer, the diameter of which was just less than that of the test-tubes. The blocks were then cut obliquely, and jammed in the test-tubes so that they did not move, and closed with the usual precautions. By this

\* Centralbl. f. Bakteriol. u. Parasitenk., iii. (1888) pp. 735–40, 763–8 (1 fig.).

† Zeitschr. f. Hygiene, iii. (1887) p. 295.

procedure 30 different kinds of bacteria were bred, which developed between 56° and 58°. With higher and lower temperatures different kinds of bacteria appeared. At 68°-70°, only a few colonies developed, while if the temperature were lowered to 50° or below, the potato bacillus appeared, and this overgrew all other colonies. The author notes that these bacilli are located on the superficial layers of the mould, and that the sun's warmth must be the most powerful factor in their genesis.

**Alkali-Albuminate as a Nutrient Medium.\***—Prof. J. Rosenthal and Dr. O. Schulz make alkali-albuminate in the following manner which is simpler than that of Tarchanoff.

The albumen taken from fresh hens' eggs is separated from the chalazæ, and clarified before it is mixed with the alkali solution. This is done in the most simple way by straining the albumen through a bag made of a double layer of muslin. It should be squeezed through slowly with the hand. The filtrate, quite clean and free from bubbles, is then poured into a graduated vessel closed with a ground-glass stopper and diluted with a 1 per cent. solution of caustic soda or potash and distilled water. The proportions are, to every 5 ccm. albumen, 3 ccm. alkali solution, and 2 ccm. water. The mixture is then shaken until it froths, after which it is allowed to stand for some hours, when the shaking is repeated in order that the three constituents may be intimately mixed. The alkali-albuminate is then poured into test-tubes, Erlenmayer's bulbs, or flat glass pans, and heated over water to a temperature of 95°-98° C. for a short time. In a few minutes a jelly is produced, which in thin layers is perfectly clear, in thick somewhat opalescent, but which always possesses the consistence and transparency requisite for a nutrient medium. Heating up to 100° C. should be avoided, as bubbles are produced owing to the vaporization of the water.

The alkali-albuminate may, if desired, be modified by the addition of certain inorganic salts (NaCl, KCl, Na<sub>2</sub>CO<sub>3</sub>, Na<sub>2</sub>SO<sub>4</sub>, NaHPO<sub>4</sub>, &c.), or by diluting with other nutrient fluids; thus the authors have obtained very good results from the following mixture:—5 ccm. albumen and 2·2 ccm. 1 per cent. alkali solution mixed with meat infusion, diluted about one-half with distilled water so that the whole quantity amounted to 10 ccm.

**Preparation of Nutrient Gelatin and Agar.†**—The practical worker in bacteriology deplures, says Dr. T. L. Cheesman, jun., the loss of time usually attendant upon the preparation, and especially upon the filtration of nutrient gelatin and agar. The method formulated by Koch and closely followed by most workers, is very satisfactory in producing good, clear culture media, but a few modifications render the procedure a much less formidable one, and as the changes to be suggested are simply those of detail, it may be well to state in brief the method now in use in the Bacterial Laboratory of the College of Physicians and Surgeons, New York, which after considerable trial gives uniform and satisfactory results. One pound of finely chopped beef, as free as possible from fat and gristle, is mixed with 1000 ccm. of distilled water and kept in a cool place for 12 or 18 hours. It is then strained, cold, through a coarse cloth, into a wide-mouthed "agate ware" or "enamelled iron" vessel of sufficient size, and 5 gm. of C.P. sodium chloride, 10 gm. of

\* Biol. Centralbl., viii. (1888) pp. 307-11.

† Amer. Naturalist, xxii. (1888) pp. 472-3.

pepton, and 100 gm. of gelatin (or 10 gm. of agar) are added. This is then placed in a water-bath (to which a large handful of rock salt has been added, if agar is to be prepared) and the gelatin (or agar) melted as rapidly as possible. The fluid is then neutralized by the careful addition of sodium bicarbonate in solution, and the boiling continued for a few minutes after, in order to precipitate the phosphates.

The fluid is now cooled by running water, to such a temperature as will not coagulate the white of egg, yet not enough to solidify it, when the whites of two eggs, thoroughly beaten up, are mixed with it, and the whole boiled for half an hour.

Filtration which has usually been effected by means of filter paper, can be much more rapidly performed by the use of *absorbent cotton in large quantity*. The pores of the paper become clogged by the fine precipitates and by the cooling of the medium, and even with the use of the "hot funnel" the filtration is sometimes very slow. Cotton, on the other hand, presents in its meshes a much larger surface for the entanglement of the fine precipitates, and when used in large quantity, allows the gelatin (or agar) even when not very hot, to flow through it rapidly. The preparation of the filter is as follows:—The absorbent cotton is unrolled and sterilized in bulk in the hot-air chamber, care being taken not to char it. A 6-in. (15 cm.) glass funnel is packed full with the dry sterilized cotton, placed in in layers, in such a way as to keep it well out of the neck, and having no folds nor ridges of cotton next the glass, through which the precipitates might pass into the receiving flask. The neutralized culture medium, after being boiled with the white of egg, as above described, is strained through coarse flannel into a flask, and poured slowly upon the centre of the filter until the cotton is thoroughly soaked, and the fluid begins to run into the flask below. This moistening causes the cotton to sink considerably, and packs it in the funnel, and when packed, the fluid filters through it almost as rapidly as it is poured into the funnel. The funnel is now filled and the fluid filtered as fast as it will run through. The first filtration seldom produces a clear medium, but through the same filter the fluid may be poured again and again, each time becoming clearer, and the moderate cooling which necessarily occurs, does not sensibly retard the rapidity of filtration. When filtration is completed, a considerable portion of the medium entangled in the filter can be saved, by pressing upon the cotton with a sterilized glass rod, gently at first and near the sides, then in the centre and with considerable force. The gelatin or agar pressed from the cotton is sometimes cloudy, for which reason it is well to catch it in a separate flask.

It not infrequently happens that gelatin which filters clear precipitates phosphates on boiling; and that agar, on cooling, forms a flocculent precipitate. To insure against filling tubes with such media, it is safest always to fill one tube with the medium, and by first cooling, then by boiling and again cooling, to test the permanence of the transparency obtained. Should these precipitates form, it will be necessary to boil the gelatin in the flask, and to refilter it through a small plug of dry cotton placed in a funnel; while agar should be allowed to completely solidify, when it is again melted and filtered through a small plug of cotton. The media are now ready for tubing and sterilizing in the usual way.

The large quantity of absorbent cotton used and the considerable amount of medium lost, by remaining entangled in the meshes of the

cotton (this may amount to 200 ccm. for each of the large cotton filters employed) are unquestionably objections to this method of filtration, but in its favour it may be stated that one filter, when properly packed, serves to clear a large quantity of medium, and the great saving of time in filtering enables one to prepare a large amount of these nutrients at one operation, which may be stored for future use. Furthermore, the "hot funnel" is dispensed with.

The modifications here described may be best appreciated by the fact that they render it possible to prepare within three hours several litres of the above-mentioned culture media.

**Eggs for Cultivation purposes.\***—Dr. F. Hüppe has used eggs in the natural condition for the cultivation of micro-organisms for about twelve months. Fresh eggs are first cleaned and the shell is then sterilized with sublimate solution. They are next washed with sterilized water and wiped with sterilized cotton-wool. This done, an opening is made in the shell with an instrument (previously heat-sterilized) and then the contents are inoculated in the usual way. Before the opening is made the egg is well shaken in order to mix its contents. The opening is closed with a thin piece of sterilized paper, and then the paper coated over with collodion. By this procedure experiments have been made as to the reduction of sulphur compounds to sulphuretted hydrogen and on the cholera bacillus. For the latter purpose the procedure is very favourable, as the conditions resembling those of the intestine with regard to oxygenation are imitated very closely.

**Cultivation on Potato.†**—M. Roux has for more than a year used the following method of cultivating on potato. Without any disinfecting washing the potato is cut up into long slices and these put into test-tubes about  $2\frac{1}{2}$  cm. in diameter. About the lower fourth of these tubes is a constriction which prevents the potato slice from slipping to the bottom. The tubes (not hitherto sterilized) are then plugged with cotton wool and heated in a steam sterilizer to  $115^{\circ}$  for about 15 minutes. The pieces of potato should be thick enough not to bend. When removed from the sterilizer the surface of the potato is damp, but after being placed in a vertical position in an incubator it dries in a few hours. The potato is then ready for use. The tubes are then covered with a rubber cap and kept till wanted.

This method, by a simple modification, is applicable to the cultivation of anaerobic micro-organisms. For this purpose a side-piece is added to the test-tube just below the constriction. After inoculation the top of the tube is melted up and then the air is evacuated through the side-piece. Another done, this tube is also melted up. The bacilli of malignant oedema, when cultivated in this way, thrive extremely well.

**Simple Method for reproducing Koch's Cultivation Plates.‡**—Prof. de Giaxa records a simple method for obtaining copies of the colonies on cultivation plates by a system of coarse photography. After the plate has been removed from the moist chamber, its under surface is wiped with blotting-paper moistened with ether, and it is then placed on a piece of albumen paper which has been sensitized with nitrate of silver. The plate and paper supported by a board are then covered with

\* Centrabl. f. Bacteriol., u. Parasitenk., iv. (1888) pp. 80-1.

† Ann. Inst. Pasteur, 1888, p. 28 (2 figs.).

‡ Centrabl. f. Bakteriologie u. Parasitenk., iii. (1888) pp. 700-2 (1 fig.).

a bell-jar. These manipulations are carried out in a dark room, and having been finished the apparatus is placed in the sunlight about half a minute. The paper is next repeatedly washed in a dark room to remove the excess of silver, then placed in a gold chloride bath, and afterwards fixed in one of hyposulphite of soda. After this it is well washed and finally dried.

**Babes' modified Cultivation Vessel.\***—In fig. 151 is shown Dr. V. Babes' recent modification of his cultivation capsule. In this the edge of the lower pan is made oblique, *a*, so that the agar does not slip down when the capsule is turned about in microscopical examination.

FIG. 151.

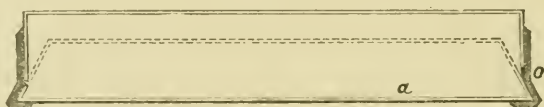

The condensation water now no longer drops upon the cultivation, but runs away down a fissure between the upper and lower pans (at *c*). Vessels made with this shape are much less exposed to infection from without than those with parallel edges. The cultivation can be closed up by means of a rubber ring *c*.

**Cooler for quickly setting Gelatin Plates.†**—Dr. A. Pfeifer recommends instead of the glass apparatus usually employed, a box made of zinc plate (the sides = 25 cm. each, and the height =  $1\frac{1}{2}$ -2 cm.) and supported at each corner on cast-iron feet. When filled with water the box may be made to acquire any temperature. Water from 8°-10° R. suffices to set gelatin in a very short time, and when manipulating agar plates, warm water may be used to prevent the agar from setting too quickly. This apparatus does away with ice, is very cheap, certain, and saves a lot of time.

**Collecting and Preparing Characæ.‡**—Mr. T. F. Allen says that to gather Characæ successfully a dredge must be used; for shallow water a small fine-toothed rake is preferred, but for deeper water (one rarely finds them at a greater depth than 10 feet) the dredge and line are essential. The best dredge for all purposes is the one recommended by Prof. Nordstedt, made as follows:—A disc of lead about 3 in. diam., and  $\frac{3}{4}$  in. thick has imbedded in its circumference a row of hooks, about 10 in number; through the centre of this disc is passed an iron rod, which projects about 3 in. below the disc, and about 9 in. above; to the ring in the upper end toward which the points of the hooks are directed, a cord is attached. The dredge weighs about  $2\frac{1}{2}$  lb., and catches all sorts of "weeds" growing on the bottom.

The dissection of these plants is perfectly simple. The delicate species are placed in water until their normal form is restored (if they have been dried), and a portion is put in a "cell" on a glass slide, and examined under a 2 in. objective; sometimes, but rarely, a higher power

\* Centralbl. f. Bakteriöl. u. Parasitenk., iv. (1888) p. 26 (1 fig.).

† Deutsche Med. Wochenschr., 1887, No. 42.

‡ 'The Characæ of America.' Cf. Amer. Naturalist, xxii. (1888) pp. 455-7.

is needed for determining fine points, such as the structure of the cortex. Should these species be incrustated with lime, a piece should be placed in a little strong vinegar till the lime is completely dissolved, then washed in pure water and examined. Specimens foul with mud must be cleaned in water with a camel's hair brush, but this is liable to detach the globules of fruit, and is only occasionally to be resorted to. Should it be desirable to preserve bits for future reference, they are best mounted in glycerin-jelly, in cells deep enough to avoid crushing, and shallow enough to permit free examination (flattened brass curtain-rings make excellent cells). When the jelly has dried at the edges, turn on a ring of white zinc cement.

#### Cultivation of Lichen-forming Ascomycetes without Algæ.\*—

Dr. A. Möller has, in a number of lichens, especially crustaceous lichens, succeeded in cultivating on nutrient media the fungus from ascospores and spermatia to the exclusion of gonidia, considerable thalli being formed, and in two kinds even spermogonia. The cultivations were rendered difficult in one way by the extremely slow growth of the objects, and in another by the presence of bacteria and saccharomyces. To meet the latter inconvenience the author took the apothecia from places which were as free from dust as possible, and placed them under a stream of water for 10 minutes, and by so doing a few pure cultivations were obtained. When the cultivations on the slides had become visible to the naked eye they were placed in flasks of the same shape as Erlenmayer's bulbs, some in nutrient media, some on sawdust &c., and the flasks closed with filter paper.

**Apparatus for Infecting.**†—Herr N. W. Diakonow proposes the following plan for the culture of fungi. The advantages claimed for the process are:—(1) the absolute purity of the culture from admixture with any other species; (2) the possibility of carrying on the culture in several different vessels at the same time; and (3) the equal distribution of the spores over the whole surface of the nutrient fluid, and the consequent unimpeded growth of every separate mycelium. The author has cultivated *Penicillium glaucum* with great success in this way.

The apparatus (fig. 152) consists of a centre-vessel A, and a number of side-vessels C surrounding it in a circle. To the upper neck of A is fixed, by an india-rubber connection, a tube B, dipping deep down into the vessel; the upper broad half of this tube is loosely filled with cotton-wool; the whole tube is easily movable in all directions. A number of short glass tubes *a*, usually from 4 to 7, are fused into the vessel A in a horizontal plane, at equal distances from one another. To these glass tubes *a* are fixed, by india-rubber connections, the side vessels C of any desired form and size. Each of these vessels has a small glass tube *c* fused into it at the same level as the tubes *a*; the ends of these tubes, about 2 cm. in length, project into the vessels, and are curved at right angles downwards.

When the apparatus is about to be used, each of the side vessels is provided either with the same or with different nutrient fluids. In the centre vessel is also placed a nutrient mixture of glucose and peptone. The side-necks *d* and *e* are then stopped with wads, and all the vessels sterilized at the same time by boiling. During the boiling the cocks *b*

\* Unters. Bot. Inst. Münster i. W., 1887, 52 pp.

† Ber. Deutsch. Bot. Gesell., vi. (1888) pp. 120-6 (1 fig.).

are left open, so that the steam may produce its sterilizing effect in all parts of the apparatus. When the sterilizing is completed, the cocks *b* are closed, and then, after cooling, the germs are introduced with all

FIG. 152.

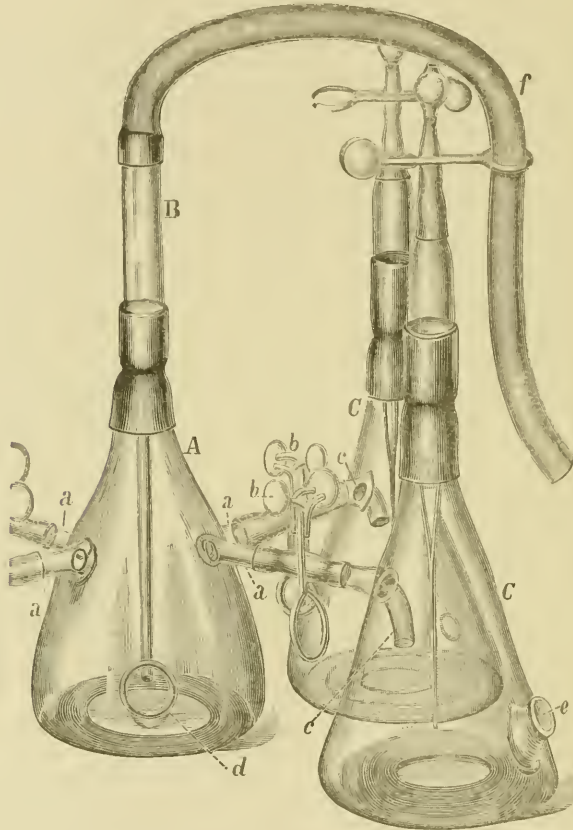

needful precautions, into A through the side-neck *d*. As soon as the conidia in A have developed fertile mycelia, the infection of the side-vessels may be effected.

For this purpose the side-neck *d* is closed by an india-rubber cap or in some other way, and an india-rubber tube *f* fixed to the glass tube B. The cocks *b* are then opened, the tube B moved by the hand in all directions, and a current of air blown through *f* and B into the centre vessel A; and the conidia are thus blown through the connecting-tubes *a* and *c* into all the side-vessels C. The side-vessels can then be detached at pleasure.

HANSEN.—La culture pure de la levure. (The pure culture of yeast.)

*Mon. Scientif.*, XXIX. (1887) p. 1033.

JACKSON, R. T.—Catching fixed forms of Animal life on transparent media for study.

*Science*, XI. (1888) No. 275, 3 pp.

- KLEMENSIEWICZ, R.—Ein Vegetationskasten für niedrige Temperatur. (A culture chamber for low temperatures.) *Wiener Klin. Wochenschr.*, 1888, p. 283.
- NOEGGERATH, E.—Ueber eine neue Methode der Bacterienzüchtung auf gefärbten Nährmedien zu diagnostischen Zwecken. (On a new method of bacteria cultivation on coloured nutrient media for diagnostic purposes.)  
*Fortschr. d. Med.*, VI. (1888) pp. 1-3 (1 pl.).
- UNNA, P. G.—Die Züchtung der Oberhautpilze. (The cultivation of skin fungi.)  
*Monatschrift für Prakt. Dermatol.*, 1888, pp. 465-76.
- ZAGARI, G.—La Coltura dei Micro-organismi Anaerobi. (The culture of anaerobic micro-organisms.)  
*Giorn. Internaz. Sci. Med.*, 1888, p. 218.

## (2) Preparing Objects.

**Effect of Hardening Agents on the Ganglion-cells of the Spinal Cord.\***—Dr. S. Trzebinski has experimented on a number of hardening media to ascertain whether and in what way they affect the ganglion-cells of the spinal cord in rabbits and dogs.

(1) Müller's fluid: hardening 4 to 5 weeks. The preparations were either washed before being placed in spirit, or were placed in spirit in the dark without being washed. The spirit was from the first of 96° or it was made weak (10°), and increased in 5 days to 96°.

(2) Hardening in spirit either of 96° at once or by increased strengths as in No. 1.

(3) Hardening in chromic acid. The preparations were placed for 6 hours in a 0·1 per cent. solution, then for 48 hours in a 0·25 per cent. solution, and were afterwards hardened in spirit or in a mixture of Müller's fluid and spirit.

(4) Hardening in 10 per cent. sublimate solution (8 days) with subsequent hardening in spirit which contained 0·5 per cent. iodine.

The stains used were, borax-carminé, alum-carminé, with or without previous staining in Weigert's hæmatoxylin solution, magenta-red, and Weigert's method. Fresh preparations were coloured with methyl-green. In fresh preparations stained with methyl-green the ganglion-cells were on the whole well stained, their finer structure recognizable, and there was no evidence of pericellular spaces. In all the preparations treated by the above hardening methods the ganglion-cells were altered, (1) pericellular spaces appeared; (2) vacuoles in the cell-substance; (3) the cell contents did not show the same structure as in the fresh cells; (4) the susceptibility of the cell contents for dyes had become inconstant. On the whole the most satisfactory method seemed to be the sublimate process which was followed by iodized alcohol.

**Sublimate as a Hardening Medium for the Brain.†**—Herr A. Diomidoff hardens brains and cords in 7 per cent. watery sublimate solution. The preparations, which should not be larger than 1 ccm., are left in the solution not longer than five to nine days, and then passed through successively 50°, 70°, and 90° spirit. In each spirit the preparation remains about twenty-four hours, so that the whole hardening occupies about eight days.

The chief point in the author's paper consists in his observation that all hardening fluids which contain mercury salts alone or in combination with silver solutions, or solutions of the latter in combination with chromic or copper salts, produce after long action on nerve prepara-

\* Virchow's Archiv, cvii. (1887) pp. 1-17.

† Wratsch, 1887, pp. 472-4. Cf. Zeitschr. f. Wiss. Mikr., iv. (1887) pp. 499-500.

tions, precipitates or albuminates which are indistinguishable from natural pigment, and for which they have been repeatedly mistaken.

Preparations hardened in the above manner can be made into very thin sections, and are easily stained with anilin colours, but are not susceptible of being treated by Weigert's hæmatoxylin method. Safranin stains the chromoleptic substance very beautifully. Over the freezing and alcohol hardening the sublimate alcohol method has the important advantage of not altering the contour of the cells.

With regard to the pigment produced along the vessels and in the nerve-cells, it was found that it disappeared entirely therefrom after long immersion in warm distilled water. Alcohol and ether had no effect except to change the black into brown. Caustic potash dissolved in spirit or 25 per cent. acetic acid had no action. 25 per cent. nitric acid destroyed it slowly, while a 30 per cent. solution of iodide of potassium converted it into a yellow-brown, and the strong Lugol solution quite effaced it in five minutes. Cold distilled water dissolves it after several weeks.

This artificial black pigment, according to the author, is either a compound of a metal and of albumen, or the result of a simple mechanical saturation of the tissue, probably the former.

**Preparation of *Criodrilus lacuum*.**\*—In his investigation into the structure of *Criodrilus lacuum* Dr. A. Collin examined living specimens, and sections prepared with Jung's microtome. Hardening was generally effected by a mixture of one part of corrosive sublimate and one part 70 per cent. alcohol. The pieces were left in the mixture for from thirty minutes to one hour, according to their size. They were then placed in water or weak spirit for some time, dehydrated by alcohol and chloroform, and imbedded in paraffin. Neither chromic nor picric acids are adapted for hardening worms. Specimens were killed with chloroform, and died without any violent muscular contraction. The staining of the pieces was best effected by ammoniacal picrocarmine; the sections were successfully stained by methylen-blue or borax-carmine with acetic acid; the former coloured the ganglionic cells, and the latter the nuclei of the epithelia and of the connective tissue. Macerations were effected partly with Müller's solution and partly with potash.

**Method of Preparing Tegumentary Filaments of Flagellata.**†—M. J. Künstler refers to the well-known fact that flagellate Infusoria, when treated with certain reagents, become covered with a variable, though often very considerable quantity of filaments, which are sometimes very long, and that an analogous phenomenon may be observed in ciliate Infusoria. In the latter, however, each filament is derived from a small refractive capsule, placed in the peripheral layer of the body. Till their homology shall be disproved all these processes may be called trichocysts. The best way to prepare them is to treat perfectly fresh specimens with concentrated osmic acid, so as to fix them, and then to colour them very slowly by diffusion by means of picrocarminate of ammonia. A less delicate method, by which one can at least determine whether or no a given species has trichocysts, is to fix a specimen with concentrated

\* Zeitschr. f. Wiss. Zool., xlvi. (1888) pp. 474-5.

† Comptes Rendus, cvii. (1888) pp. 138-9.

osmic acid, and colour it with Collin-black acidulated by chromic acid to which glycerin has been added.

**New Method for making Microscopical Preparations from Test-tube Cultivations.\***—Dr. R. Fischl recommends the following procedure for obtaining microscopical preparations from test-tube cultivations:—By means of a cork-borer the central track is removed from the gelatin. This gelatin cylinder containing the micro-organisms is then placed for 24–48 hours in 96 per cent. alcohol or in a mixture of equal parts of ether and alcohol, and then sectioned on a microtome between cork layers. The sections are then stained by Gram's method, the micro-organisms alone retaining the stain. The author has applied the foregoing to the examination of ferment-fungi with excellent results.

**Chitin Solvents.†**—Mr. T. H. Morgan reports the results of experiments which he has made with chitin solvents. He followed a prescription recommended by Dr. Loob,‡ namely, Labaraque solution (potassium hypochlorite) and Javelle solution (the corresponding sodium compound). Mr. Morgan used the solutions successfully in two forms, strong as in the commercial fluid, weak when diluted from five to six times with water. In most cases the strong solution acts too rapidly and powerfully. The preparations after removal of the chitin were hardened in picro-sulphuric acid, corrosive sublimate, or different strengths of alcohol. The method was also used for specimens already hardened and preserved. The experiments seem to show that something else in the compound besides free chlorine is brought into play.

**Preparing Slides to show Brownian Movement.§**—Prof. H. M. Whelpley says that permanent mounts to illustrate the phenomenon of pedesis are not difficult to make, "provided, however, that the motion does not cease after a few days, as claimed by some authorities." He has "no reason for doubting the statement of one writer, who says he has a mount six years old that shows the movement nicely and as well as it ever did." Place a well-cleaned slide on the turntable and run a ring of cement on it about 0.5 mm. high. In warm weather, or in a warm room during winter, the cement will become sufficiently dry in a half hour to permit of finishing the mount. This is accomplished by placing in the cell a large drop of a liquid made by mixing carmine or other powders || with 100 times its volume of water, and placing in position a well-cleaned cover-glass. When the cover is pressed down, the superfluous liquid will be pressed out and the fresh cement will hold the cover firmly to the cell. The pressure reduces the depth of the cell to about 0.25 mm. The slides should be washed to remove any particles of the powder that may have run out with the liquid and been deposited on the cover-glass. When dried it is ready for use, and such a mount, at least as far as the mechanical part is concerned, will last a lifetime. Either white zinc cement or Brunswick black can be used.

\* Fortschr. d. Med., v. (1887) p. 653.

† Stud. Biol. Lab. Johns-Hopkins Univ., iv. (1888) pp. 217-9.

‡ See this Journal, 1885, p. 896.

§ Amer. Mon. Micr. Journ., ix (1888) pp. 125-7.

|| Vermilion, cobalt, wood charcoal, indigo, camboge, pumice stone, carbonate of lead, glass.

- BENDA, C.—Eine neue Härtungsmethode besonders für das Centralnervensystem. (A new hardening method especially for the central nervous system.)  
*Centrabl. Med. Wiss.*, XXVI. (1888) p. 497.
- GIESON, J. VAN.—A Résumé of recent Technical Methods for the Nervous System.  
*Journ. Nerv. and Mental Diseases*, XIV. (1887) p. 310.
- GIFFORD, J. W.—Preparations for High Powers.  
[Beale's glycerin-carminé fluid—Gum and glycerin and glycerin jelly—Modification of Flemming's chromo-aceto-osmic acid.]  
*Journ. of Micr.*, I. (1888) pp. 152-4.
- KLEIN, L.—Beiträge zur Technik der mikroskopischen Dauerpräparate. (Contributions to the technique of permanent microscopical preparations.)  
*MT. Bot. Vereins Freiburg*, 1888, Nos. 49-50.
- RUDANOWSKI.—Making Microscopical Nerve Preparations by dividing the nerves into primitive bundles by chemical processes, and the latter into their component parts.  
*Russkaja Medicina*, 1887, No. 38 (Russian)
- WOODHEAD, G. S.—Method of preparation of large sections of the Lung.  
*Brit. Med. Journ.*, 1888, p. 737.

### (3) Cutting, including Imbedding.

**Photoxylin for Imbedding.**—Dr. Krysiniski \* suggests the use as an imbedding substance of photoxylin, a kind of pyroxylin used by Russian photographers, and which he considers superior to celloidin on account of its keeping without deterioration, and remaining clear in solution or mass. Mr. G. M. Beringer,† who has experimented in the production of photoxylin, finds that the following formula gives the best results:—Nitrous acid, 43° R., 3½ lb. av.; sulphuric acid, 4½ lb.; potassium nitrate, granular, 8 oz.; wood pulp, 4 oz.

The nitrous and sulphuric acids are mixed in an earthenware crock and allowed to stand until the temperature has fallen to 90° F., when the potassium nitrate is added and thoroughly incorporated with the acid mixture. The wood pulp is then immediately immersed in the mixture and allowed to remain for twelve hours. It is then removed from the acid and thoroughly washed.

The material thus obtained is quite soluble in equal parts of ether and absolute alcohol. For general work Krysiniski recommends two solutions; a thin solution (1/2 to 1 per cent.), and a 5 per cent. The specimen is placed from strong alcohol into the thin solution, to remain from twelve to twenty-four hours, when it is transferred to the thicker solution. To fix the specimen before cutting, it is only necessary to place it on a cork. A film soon spreads over the mass, which is then submerged in 70 per cent. alcohol, and after two or three hours is ready for sectioning.

**Paraffin-imbedding Process in Botany.**‡—Within a few months there have appeared two articles§ on this subject, and as Mr. D. H. Campbell has been devoting some attention to it lately, he thinks it may be of interest to state briefly the results obtained. It was found convenient to combine to some extent the methods given in the articles referred to, as neither was found in all respects satisfactory, and some simplifications of the processes were made which were found advantageous.

\* Virchow's Arch. f. Path. Anat. u. Hist., 1888. Cf. The Microscope, viii. (1888) p. 183.

† Amer. Journ. Pharm., 1888. Cf. *ibid.*

‡ Bot. Gazette, xiii. (1888) pp. 158-60.

§ Schönland, S., Bot. Centralbl., xxx. (1887) pp. 283-5. See this Journal, 1887, p. 680. Moll, Bot. Gazette, xiii. (1888) pp. 5-14. See this Journal, *ante*, p. 315.

The experiments were made upon the germinating macrospores and the young embryos of *Pilularia globulifera*, and the results obtained warrant a very strong recommendation of the imbedding process where the sectioning of very delicate tissues is necessary; indeed, when the results thus obtained are compared with the imperfect and uncertain methods ordinarily used in such work, no one who has used both will hesitate as to their comparative merits. With the firmer plant tissues there is usually no necessity for any imbedding process, and owing to the time and care necessary to successfully apply this method, it is not to be recommended in such cases.

In regard to the best hardening agents, Schönland and Moll disagree, the former recommending alcohol, which Moll does not consider satisfactory, preferring chromic acid or the mixture of chromic, osmic, and acetic acids used by Flemming. There is no question that for many purposes absolute alcohol is to be preferred, owing to its convenience and the perfection with which it ordinarily preserves all plant tissues. With mixtures of chromic, picric, or osmic acid thorough washing is necessary after hardening; but as Moll rightly remarks, where cuticularized cell-walls are present it is extremely difficult to get the paraffin to penetrate such membranes, whereas it is much easier where fixing solutions containing chromic acid are employed. A practical illustration of this was found in the very thick-walled macrospores of *Pilularia*.

After the material is thoroughly hardened, and, in the case of alcoholic material, allowed to remain for twenty-four hours in borax-carminé, it is treated as described by Schönland. For the gradual transfer from 30 per cent. to absolute alcohol the Schultz apparatus\* was found most serviceable.

The following method of imbedding was found practical and simple:—A small paper box is made by taking a strip of pretty firm paper and winding it tightly about an ordinary cylindrical cork, fastening the paper with a little gum arabic, and holding it in place with a pin until dry. On taking out the pin the paper cylinder can of course be slipped off the cork. The box is completed by cutting out a round piece of paper of exactly the size of the cylinder, and putting this into the cylinder as the bottom of the box. The object to be imbedded is placed horizontally upon the bottom, and the melted paraffin poured over it, after which the whole is placed in a shallow flat-bottomed vessel filled with melted paraffin. Thus there is no possibility of the paraffin's escaping, which otherwise it is almost impossible to prevent, and there is also no necessity of handling the objects after they are once in the paraffin, which in the case of small objects is a great advantage. In case the objects are displaced in pouring the paraffin over them, it is a simple matter to adjust them, using a heated needle for this purpose.

In order to insure thorough saturation, the objects were usually left overnight in the melted paraffin, and then, as in the articles mentioned, quickly cooled to avoid the formation of bubbles. The vessel containing the paper boxes may be exposed to the air for a few minutes until a thin film has formed over the surface of the paraffin in the latter, when these may be quickly lifted out and plunged into cold water. As soon as the paraffin is thoroughly hard, the pasted seam in the paper cylinder may be loosened with the blade of a knife or scalpel, when it will be found

\* Strasburger, Bot. Prak., 2nd ed.

that the paper separates readily from the inclosed paraffin, and on removing the bottom of the box in the same way the result is a solid cylindrical block of paraffin, with the object to be cut lying horizontally close to the smooth lower face, so that the sectioning is easily regulated.

Schönland recommends paraffin with a melting-point of about 45° C., but the author found this much too soft to cut well, and prefers (as Moll recommends) a harder sort, melting at about 50° C. Schönland again says that a temperature above 50° C. is to be avoided, but in no case has the author found that a temperature of 50°–55° C. was in the least degree hurtful.

For sectioning the rocking microtome used by Schönland was employed, and found in every way satisfactory.

Moll describes fully the fixing processes, but the author's experience has been that it is not desirable to hasten the staining process. Safranin was mainly used, and the best results were had by allowing the sections to remain for about twenty-four hours in a very dilute watery solution. At the end of this time they should be deeply stained. The slide is then plunged in absolute alcohol until the excess of the colour is removed, and when this is accomplished, and most of the alcohol has been removed from the slide with a cloth or blotting-paper, taking care of course not to touch the sections, a few drops of xylol are applied, and allowed to remain until the sections look perfectly transparent, when a drop of Canada balsam dissolved in xylol or chloroform may be applied, and a cover-glass put over the preparation, which is now complete.

The employment of soft paraffin in order to make the sections adhere, as described by Schönland, is quite unnecessary, as the sections adhere perfectly without this; indeed, it is much easier to get a good ribbon of sections without the soft paraffin than with it, owing to the difficulty of perfectly removing the surplus soft paraffin.

**Further Notes on Celloidin Technique.\***—Dr. S. Apáthy communicates some further instructions for manipulating celloidin by way of supplement to his previous paper.†

(1) How to keep celloidin blocks.—If cork be used for sticking the celloidin blocks on, it must first be saturated with soft paraffin in order that the 70–80 per cent. spirit in which the object is to be preserved may not be spoilt by the tannic acid. But as celloidin will not adhere to paraffin, the latter must be shaved off from one end, and then this end, together with the celloidin block which has been stuck on, is plunged for a second in some paraffin heated above its boiling point. In this way a block of celloidin can be kept even without spirit without any danger of its becoming dry. Sectioning must, of course, be done with a dry knife. The thin casing of paraffin, even if it does not fall off of itself, can be dissolved at once in bergamot oil, and offers no difficulty. If it be desired to discontinue making sections, it is only necessary to cover the exposed surface with a drop of paraffin.

(2) Writing on celloidin.—Mark the bottom of the paper case in which the object is to be imbedded with a lead pencil. Then, when the paper case is stripped off from the block consolidated in 70–80 per cent. spirit, the writing will be found transferred to the celloidin, and in order to

\* Zeitschr. f. Wiss. Mikr., v. (1888) pp. 45–9.

† See this Journal, *ante*, p. 670.

preserve it there it is only necessary to brush over the surface a layer of thin celloidin.

(3) Staining of the series.—The arrangement of unstained sections or of very small objects may be facilitated by adding to the bergamot oil a few drops of an alcoholic solution of safranin. The sections stained rose-colour are then easily visible. This staining of the celloidin disappears in a day or two, and in a few hours after exposure to sunlight. If now the series, which is placed on a slide, and from which the oil has been mopped up, is to be stained, the slide is placed in a capsule, on the bottom of which are a few drops of ether and absolute alcohol. The series clears up at once, and the celloidin is so far softened that it cleaves firmly to the slide. As soon as drops of ether and of absolute alcohol appear on the slide, it is at once removed to another capsule containing 90 per cent. spirit, whereby the celloidin is hardened, and all trace of the bergamot oil removed. After a quarter of an hour the slide may be placed in any stain which is free from water or contains at least 70 per cent. spirit. If aqueous staining solutions are to be used, care must be taken that when exposed to the alcohol-ether vapour the celloidin sections overlap, or at least touch, so that the series may be treated as one large section.

(4) Applying direction-lines to the celloidin block.—As a general rule, the sides of the block suffice as direction-lines, provided that the celloidin is distinguishable from the outline of the object. This distinction may be rendered more evident by adding to the fluid celloidin or to the bergamot oil a few drops of some pigment dissolved in 90 per cent. spirit, such as picric acid or carmine, dyes which stain celloidin much more quickly than the object.

If it be necessary that the position of an object should be very accurately determined, it is better to imbed in the celloidin a thin plate of gelatin and to arrange the object upon this. By this means there is in each section a fixed outline with fixed end-points, and for the purposes of plastic reconstruction leaves little to be desired as regards orientation.

(5) Modification of the method of staining with hæmatoxylin and the chromic acid salts.—The author finds that a modification of Haidenhain's method for staining celloidin series prevents the sections from becoming overstained and brittle. He now uses hæmatoxylin and the chromic salt in 1 per cent. solutions in 70–80 per cent. spirit. The bichromate solution is made by mixing 1 part of a 5 per cent. solution of bichromate of potash with 4 parts of 80–90 per cent. spirit. Not only must the solution be kept in the dark, but the object must be stained, treated with alcohol, and imbedded in the dark.

**Bruce's Microtome for cutting whole sections of the Brain and other organs.**—This instrument (fig. 153) was designed by Dr. A. Bruce to meet the requirements of those who wish to cut sections of 4 in. diameter and upwards. The construction was necessitated by the inconveniences which were found to attach to large microtomes made after the manner of Rutherford's microtome. The method of freezing adopted in Rutherford's instrument is well adapted for freezing tissues of moderate size, where the freezing mixture is at a small distance from the tissue, but is quite unsuited for a tissue of 4 or 5 in. diam., where some part of the object to be frozen would be at least  $2\frac{1}{2}$  in. from the freezing mixture.

In the new instrument freezing is effected by laying the object to be

frozen upon a zinc plate A connected with metallic pillars, which are surrounded by a freezing mixture, as in the Williams microtome. In order that the plate may be quickly and effectively cooled to a temperature sufficient to freeze a tissue placed upon it, it is put in con-

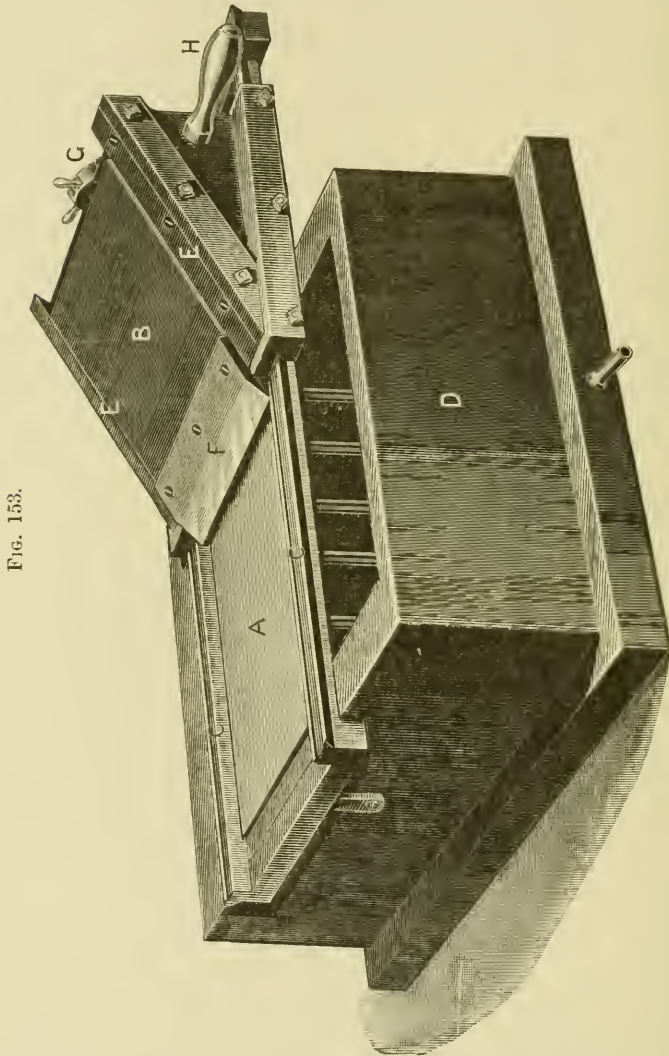

FIG. 153.

nection, not with one, but with twelve pillars, which rest upon the bottom of the freezing-box D, and are in close metallic contact with the plate. In order to further increase the effect of the freezing mixture, the pillars are made of a cruciform shape in their transverse section, as shown in fig. 154. The freezing mixture of ice and salt is passed between the

pillars and against their arms, and this process is found so effective that tissues of 6 in. diam. and upwards, and half an inch in thickness, are frozen through in twenty minutes. Dr. Woodhead has made a further improvement in the method of freezing by placing a shallow box filled with a freezing mixture upon the plate. This box, the under side of which is immediately over the tissue to be frozen, considerably accelerates the freezing process. FIG. 154.

The knife F is attached to a plate B, which slides in grooves in the "plough" E E, and is moved forward or backward by a screw. The capstan head is shown at G. As the knife is placed obliquely, it moves but a small distance vertically for each forward movement of the screw, so that a comparatively coarse screw is as efficient as a fine one would be if acting vertically. The plough is moved backwards and forwards by two handles, one of which is shown at H, travelling in the rails at C C. All the parts are made with "fitting strips," as in a slide-rest, so that wear may be readily taken up.



The dimensions of the apparatus are as follows:—Freezing-box, length 22 in., breadth 12 in., depth 8 in.; rails upon which the plough slides, 34 in. long and 1½ in. wide; plough, 14 in. long and 8 in. high; knife, 9 in. on cutting face.

The microtome is made by Mr. A. Frazer, scientific instrument maker, of Edinburgh.

**Thate's New Microtome.\***—Herr P. Thate has invented an immersion microtome which possesses advantages in its arrangement of the knife-carrier and circumvents certain difficulties inherent in the sliding microtome. It is fully represented in fig. 155.

The three columns  $S_1 S_2 S_3$  are connected near their base by a triangular cast-iron piece. The pillar  $S_1$  is hollowed out at the top, so that the arm A, about 50 cm. long, may be worked through the ball-joint. The columns  $S_2 S_3$  are joined by the arciform piece B, along the upper surface of which the end of the arm A, expanded at its extremity, works. The expanded end of A is supported on two hard steel knobs. The arm A is moved to and fro by the handle *k*. About 20 cm. from its free end the piece A is perforated by a slit through which the tap of the binding-screw C projects, and by means of which the knife-carrier is clamped to the arm A. For this purpose the lower end of C is swallow-tailed, so that it may be pushed into a corresponding opening in the double piece D, and that when the binding-screw is tightened it is fixed to the arm A. The ends of D are gripped by the block E E, joined together by a flat horizontal plate. To the under surface of E E the ends of the knife are screwed, while through their upper extremities pass the screws binding E E to D. Consequently, by altering the screws in E E and the screw C, the knife can be placed in any desired position. The amount of vertical movement of the edge of the knife, which, of course, moves through part of a circle, is shown by the indicator at E. F is the clamp for holding the specimen, and K the pan or well which contains the fluid, water, or spirit. The clamp and well are formed in one piece and fixed to the tube J, which in its turn passes through the block G, and is fixed in any position by the binding-screw S. The fine-adjustment of the block is effected by the micrometer-screw M,

\* Zeitschr. f. Instrumentenk., viii. (1888) pp. 176-7 (1 fig.).

which passes through G, and the latter in its turn is supported on an inclined plane formed by the bars L. Every raising of the block G, 0.005 mm., is indicated by an audible click produced by the plate H. The last arrangement is ungeared by means of the handle *h* when the

FIG. 155.

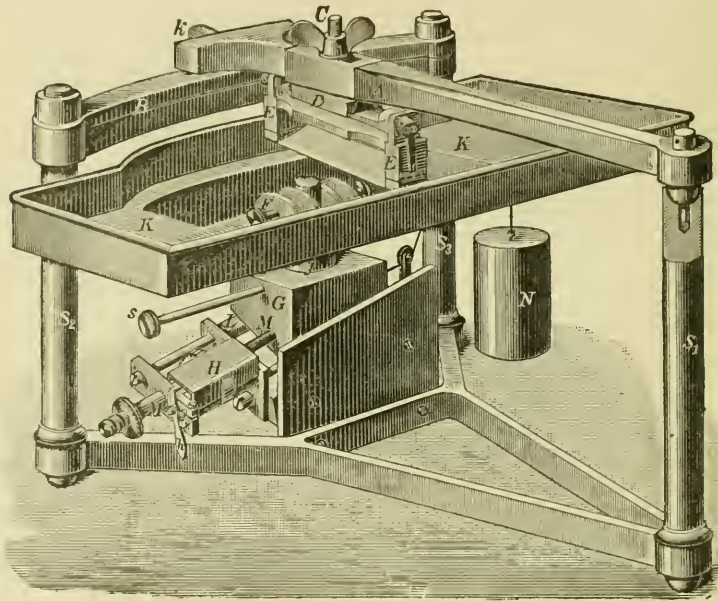

coarse-adjustment of the preparation is necessary. The pressure of the block G on the micrometer-screw is obviated by the counterpoise N suspended by a cord running over two rollers.

**Accessory for rapid Cutting with the Thoma Microtome.\***—Herr J. Erdős has devised an arrangement for the Thoma microtome whereby the knife-carrier is set in motion by pedals, thus leaving both hands free to manipulate the sections, &c. This is claimed to be an improvement, as heretofore the right hand was employed in moving the knife along, &c., while the left was used merely for preventing the section from rolling up.

A plate about  $1\frac{1}{2}$  cm. in diameter, and perforated by a hole in its centre, is fixed to the knife-carrier by means of its binding-screw. Either end is terminated by a small hook. These hooks are connected with cords which run over pulleys (see fig. 156) to pedals. On the end of the microtome farthest from the pulleys, the cord runs over two pulleys, on the nearer side over one. Both cords then pass over another pair of pulleys which are fixed to the edge of the table, and then pass down to the pedals.

It is advised to fix the microtome to the table by means of strips of

\* Internat Monatschr. f. Anat. u. Hist., ii. (1885) pp. 343-6 (1 fig.).

wood nailed to the table round the instrument, so that it cannot move while being worked.

The sections are prevented from rolling up by fixing in the joint of

FIG. 156.

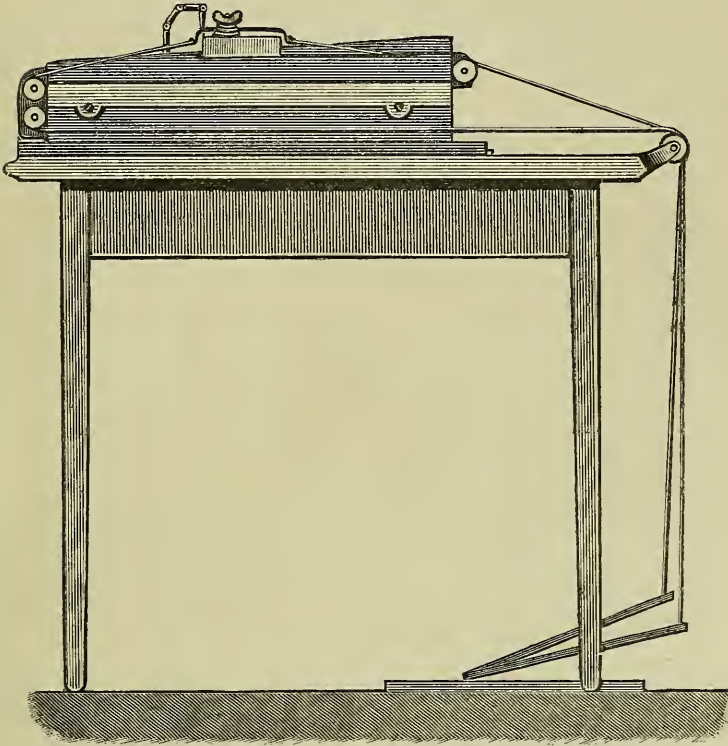

the object-holder a camel's-hair brush, so that the latter just touches the surface of the section or the paraffin.

**New Section-stretcher, with arrangements for removing the Section.\***—Prof. H. Strasser describes a device invented by him for keeping sections straight and causing them at the same time to adhere to a paper band which is one of the principal parts of the apparatus. Over the object and the knife-blade a paper band is arranged parallel to the long axis of the microtome. One end is clamped to the object-holder, and the other kept taut by a weight connected with the band by a cord running over a roller. The band is made to just touch the surface of the object by means of a metal roller of 1 to  $1\frac{1}{2}$  cm. in diameter. The roller can be placed in any position by means of a universal joint, and it is made to move up and down in the same groove as the knife-carrier, by means of a similar carrier. The roller is then adjusted parallel to the edge of the knife, and thus the section is kept from curling up by the superjacent

\* Zeitschr. f. Wiss. Mikr., iv. (1887) pp. 218-9.

pressure. The under surface of the paper band is rendered adhesive by means of gum and collodion, and thus by each action of the knife a new section is placed in position along the band, the front end of which must be snipped off to remove the piece carrying the section, and then reclamped.

BALTZAR, G., and E. ZIMMERMANN.—*Microtom mit festem Messer und selbstthätigem Vorschub des Objekts.* (Microtome with fixed knife and automatic movement of the object.) German Patent, Kl. 42, No. 1431, 1888.

[MANTON, W. P., and others.]—*Modern Methods of Imbedding.*

*The Microscope*, VIII. (1888) pp. 181-4.

STOWELL, C. H.—*Thin Sections.*

*The Microscope*, VIII. (1888) pp. 175.

#### (4) Staining and Injecting.

**Double-staining of Nucleated Blood-corpuscles.\***—Dr. W. M. Gray gives the following directions:—Spread a thin layer of blood on a clean slide and dry. Immerse the slide in a beaker of alum-carmine (Grenacher's formula) for five minutes; wash in clean water, and immerse in a beaker of a weak solution of sulph-indigotato of soda or potash (the solution should be of a dark-blue colour—not black-blue, as in a strong solution). After the slide has acquired a purplish hue, wash in water and dry. After drying, warm slightly and mount in balsam. The nuclei will be a beautiful red, and the protoplasm a greenish blue.

**Vital Methylen-blue Reaction of Cell-granules.†**—If the larvæ of the frog or triton, says Dr. O. Schultze, be placed in a watery solution of pure methylen-blue, of the strength of 1:100,000-1,000,000, after twenty-four hours, certain granules in the cells of the cutaneous epithelium become stained with the weakest solution; the staining is confined to a small spot close to the pylorus which to the naked eye resembles a small blue ring. When the strongest solution is used for eight days, all the parts become of a deep blue colour. The pigment is absorbed by certain granules within the cells and causes them to swell up. These are identical with Altmann's bioblasts. These granules are not stained, or at any rate very slightly, when the dye is introduced through the blood-current, while, on the other hand, in larvæ living in the blue solution, the nerves are not stained. If the larvæ be removed from the blue solution to pure water all trace of the pigment disappears in eight days.

**Differential Staining of the Tissues of Living Animals.‡**—M. A. Pillicet has found that, by a simple subcutaneous or intra-peritoneal injection of methyl-blue, in rats, guinea-pigs, and other small animals, the entire kidney and some other organs are stained a diffused blue. By mixing the same material (methyl-blue) with the food of rats and guinea-pigs, only the glomerules of the kidneys were stained. If, instead of blue, fuchsin be used, the entire kidney becomes stained a vinous red, which, under section, however, shows the glomerules and

\* Queen's Micr. Bulletin, v. (1888) p. 15.

† Anat. Anzeig., ii. (1887) pp. 684-8.

‡ St. Louis Med. and Surg. Journ., lv. (1888) pp. 28-9 from 'Progrès Médical.' Cf. also Journ. de Microgr., xii. (1888) pp. 285-90.

epithelial nuclei to have taken a much deeper colour than the balance of the structures. So marked was this in the experiments of the author, that in perfectly fresh sections these were very sharply and neatly differentiated.

A very remarkable fact was brought out in the course of Pilliet's experiments, viz. that when methyl-blue is introduced intra-peritoneally into guinea-pigs, the glomerule is stained a rose-carmine. When frogs were placed in an aqueous solution of methyl-blue, so weak that they could live in it several days, it was found that while the balance of the tissues were stained a diffused blue the glomerules showed a colour varying from rose-carmine, or rose-red, to ochre-yellow, the nuclei being more strongly tinted than the balance of the cell. In rats in which the blue had been intraperitoneally introduced, the blue was changed to red only on the surface of the glomerule. From these experiments it follows that in certain cases the glomerule possesses a peculiar oxidizing property in a high degree, since methyl-blue is a substance relatively refractory to oxidation. The significance of this discovery is that, in the kidney, the capillary circulation of the glomerules contains a large quantity of oxygenated blood, a fact which demonstrates the organ to be a true reducing apparatus and not simply a filter. We know that in the Reptilia the dark-blood returning from the tail is collected by a voluminous vein and carried to the glomerulæ, from which it departs, viâ the renal vein, not as black but as *red* blood. The kidney in this becomes a true reducing apparatus, partaking in this respect in the functions of the lung. The experiment of Ehrlich in this direction, made some three years ago, demonstrated these facts in a beautifully exact manner. By introducing intravenously into the system two substances, the combination of which gave rise to a coloured produce (indo-phenol), and which combination could take place only where oxygen existed in exceedingly feeble quantity, he arrived at a very exact knowledge of the degree of oxidation existing in any organ or part. In a similar manner, conversely, by using substances easily reducible (alizarine-blue, for instance), a scale of oxygenation may be arrived at. He thus demonstrated the scale of reductive power of the lungs, the cortical substance of the kidney, the mucous membrane of the stomach, &c. Later he established the same functions in the muscles, the liver, glands, &c.

**Staining-differences of Unstripped Muscle and Connective Tissue Fibres.\***—For distinguishing between smooth muscle-fibres and spindle-shaped connective tissue-cells, M. E. Rotterer recommends the following procedure. The fresh preparation is placed for 24 hours in a mixture of 10 vols. 36° alcohol, and 1 vol. formic acid. The hardening fluid is then quite extracted in water, after which the piece is treated with gum and spirit and then sectioned. The sections are stained for 36 hours in Grenacher's alum-carmine, and having been thoroughly washed, mounted in glycerin or balsam. The protoplasm of the unstripped muscle-fibres then appears red, the nucleus having a darker tinge. The cell contour is quite sharp. Connective tissue is quite colourless or rose-coloured, the cells are swollen, and their boundaries ill-defined. From this the author concludes "that the contractile protoplasm of unstripped muscle is not the same as that of connective tissue."

\* Comptes Rend. Soc. Biol., iv. (1887) p. 615.

**Improvements in the Silver-nitrate Method for Staining Nervous Tissue.\***—Dr. C. Martinotti obtains the silver-nitrate reaction in large pieces of tissue, e. g. pons Varolii, by altering Golgi's method as follows:—(1) The quantity of silver-nitrate is increased relatively to the size of the object. (2) The solution is allowed to act for 13–30 days. (3) The pieces are kept at a temperature of 25°, in order that the reaction may reach the ganglion cells, but in order that all the cells of the neuroglia should participate in the reaction, a temperature of 35°–40° is necessary.

If 5 per cent. of glycerin be added to the solution, the reaction in the ganglion cells and their ramifications is facilitated. In order to prevent precipitates forming at the periphery of the pieces, these were imbedded in a mass made out of filter paper and distilled water after the objects had been taken out of Müller's fluid. This artifice was found to increase the contraction of the silver nitrate solution.

**Staining in the Study of Bone Development.†**—Dr. J. Schaffer in a large and diffuse article recapitulates the various stains which have been recommended from time to time for staining cartilage in the transition stage to bone so as to differentiate the osseous and cartilaginous elements. The method upon which the author dilates most was invented by Bouma, who found that safranin imparted a yellow colour to the cartilage, while the connective and osseous tissues appeared red. This yellow stain was supposed by Bouma to be due to the fact that safranin is not a chemically pure substance, and starting from this observation, the author proceeded to examine the relative staining capacities of several kinds of safranin in watery solution (1:2000). (1) The commercial. (2) Pheno-safranin a chemically pure dye. (3) Tetraethyl-pheno-safranin, a substance which contains NaCl. The commercial safranin gave the best differentiation, cartilage orange, bone colourless, medullary tissue red. The pheno-safranin gave similar but less marked results. The tetraethyl-pheno-safranin stained the cartilage red-violet, the bone and medullary tissue blue. The author then gives his method for fixing the stain, a 1:2000 watery solution of safranin.

The unstained sections, decalcified in nitric acid or in hydrochloric acid and salt solution, are placed for half an hour in the safranin solution. They are then washed in water and transferred for 2 to 3 hours to 1/10 per cent. sublimate solution and mounted in glycerin. If, however, the preparations are to be fixed up permanently, the sections on being removed from the sublimate solution must be passed rapidly through alcohol, dried upon the slide with bibulous paper, and left for a long time in oil of cloves or bergamot. They are then mounted in xylol balsam.

**Preparing and Staining Mammalian Testicle.‡**—For hardening the mammalian testicle, Dr. A. Prenant found that osmic acid and Flemming's fluid were the best media, Kleinenberg's picro-sulphuric acid, nitric acid, strong oxalic acid, absolute alcohol, 3 and 4 per cent. bichromate of potash being less effective. A 1 per cent. solution of osmic acid acting for one to two hours gave the best results. Of the

\* Congresso Medico di Pavia, Seduta 6a, Riforma Med., 12 Ott., 1887. Cf. Zeitschr. f. Wiss. Mikr., v. (1888) p. 88.

† Zeitschr. f. Wiss. Mikr., v. (1888) pp. 1–19.

‡ Internat. Monatschr. f. Anat. u. Physiol., iv. (1887) pp. 358–70.

various "Flemming" solutions tried, that which contained most osmic acid was the most successful. The preparations were then soaked in chloroform and imbedded in paraffin and then sectioned in a Dumaige microtome. The sections were fixed to the slide with a mixture of equal parts of albumen and glycerin. The stains used were safranin, hæmatoxylin, hæmatoxylin-eosin, acid carmine, picro-carmine, and gentian-violet. These dyes all acted very slowly on preparations treated with the Flemming solutions, but very quickly on those fixed in osmic acid.

Bizzozero's method was employed for staining the nucleus, safranin being found to be quite as good as gentian-violet for this purpose, provided that the iodine solution were allowed to act more effectually, and the spirit less powerfully.

**Stain for the Morphological Elements in Urine.\***—Dr. F. L. James has hitherto recommended for this purpose the ordinary aqueous solution of eosin. It acts rapidly, and but a small amount is needed to give all the elements so decided a tinge that the most delicate hyaline cast will rarely escape the practical eye. He recently made a solution of boro-eosin, and after a number of experiments with it, much prefers it for this purpose to the simple aqueous solution above referred to. The new stain acts more rapidly, and imparts a deeper and richer tinge to the elements. In nucleated elements the nuclei take the stain in a much more intense degree than does the balance of the structure, and as a consequence, are clearly and sharply differentially stained by it. As to its lasting properties, it is yet too early to speak, but it is reasonable to suppose that it will be quite as permanent as the stain made with the aqueous solution of eosin. This, however, is a secondary consideration, as the chief value of the stain is the rapidity and the ease with which it enables us to find otherwise difficult objects. The formula for boro-eosin is as follows:—Eosin, 10 parts; sodium biborate in powder, 15 parts; alcohol of 95°, 60 parts; distilled water, 415 parts. Dissolve the borax in half of the water. Add the alcohol to the remainder of the water, dissolve the eosin in the mixture, mix the two solutions and filter.

In using it allow the urine to stand in a conical glass until the suspended elements have in a great measure subsided. The clear supernatant fluid is siphoned, or otherwise drawn off and the stain added to the remainder. A few drops of perosmic acid solution is added at the same time. This gives the urine a dark or almost black appearance by direct light, but when examined with transmitted light, the colour is a deep rich ruby. A drop withdrawn and examined within a half hour after adding the stains will show all the elements well coloured, the epithelia and granular casts especially so. The hyaline casts will be sufficiently coloured to be very distinct, but require more time for thorough staining. Permanent mounts of urine thus prepared will last a long time without deterioration, but for preservation the author advises the use of glycerin.

**Staining Spores.†**—Dr. G. Hauser recommends the following method for staining spores. The cover-glass is passed thrice through the flame in the usual manner, and is then covered with a strongish watery solution of fuchsin. The cover-glass is then passed through the flame forty or fifty times until the stain evaporates or even simmers. If

\* St. Louis Med. and Surg. Journ., lv. (1888) pp. 98-9.

† Münchener Med. Wochenschr., 1887, p. 654.

evaporation takes place too quickly, more stain must be dropped on. The preparation is then decolorized for a few seconds in 25 per cent. sulphuric acid. The acid is washed out with water, and the preparation after stained with a weak solution of methylen blue. The time required for the whole manipulation is not more than five minutes.

**Staining Tubercle and Leprosy Bacilli.\***—Prof. N. Lübmoff recommends the following solution for staining the bacilli of tubercle and leprosy. It is called borofuchsin, and consists of fuchsin, 0·5 gr.; boracic acid, 0·5 gr.; absolute alcohol, 15 cm.; distilled water, 20 cm. It is made by first mixing the boracic acid and water, then adding the spirit, and finally the fuchsin. The latter dissolves gradually on agitation.

Thus prepared, the staining fluid has a slightly acid reaction, is transparent, clear, and as it does not deteriorate by keeping, is always ready for use. Cover-glass preparations of phthisical sputum are stained in 1–2 minutes. Sulphuric acid in the proportion of 1–5 is used for decolorizing, the cover-glasses are then washed in spirit, and then immersed for 1½ minute in a saturated alcoholic solution of methylen blue. The superfluous stain is washed off with water, and the cover-glass dried. It is advised to examine the preparation in *Ol. ligni cedri*, or in xylol balsam. Sections are treated in exactly the same way, but it is preferable to stain twenty-four hours in the borofuchsin. The author notes that lepra bacilli are much more easily and rapidly decolorized than tubercle bacilli.

**Alcoholic Solution of Hæmatoxylin.†**—Dr. G. Cuccati gives the following formula for making a hæmatoxylin solution which possesses the advantages of never going bad, and of staining only the chromatic part of the nuclei, the colour being fixed most deeply in the karyokinetic figures.

Dissolve 25 grm. of pure iodide of potassium in 25 cm. of distilled water, and pour the mixture into a glass-stoppered bottle containing 75 cm. absolute alcohol, shaking the while repeatedly.

Then grind together in a mortar 75 egrm. of hæmatoxylin crystals and 6 grm. of alum. When these are intimately mixed, add 3 cm. of the iodide solution. Keeping the mixture well stirred, add little by little the rest of the solution, and then pour into a well-stoppered bottle, and leave for 10–15 days. At the end of this period shake up well again, and in an hour or two afterwards filter and preserve the filtrate very carefully to prevent evaporation and deposit of alum or iodide crystals.

This solution only stains up to a certain point, consequently the sections may be left in it almost indefinitely.

**Osmic Acid and Gold chloride Methods.‡**—Dr. A. Kolossoff says that the penetrating power of osmic acid, which is intrinsically almost nil, may be increased by a mixture of the acid with uranium salts. The author prepares a 0·5 per cent. solution of osmic acid in a 2 to 3 per cent. solution of nitrate or acetate of uranium (the former is the better). Large pieces of an object, for example a frog's tongue cut into two or three pieces, are easily penetrated by this mixture, wherein they may

\* Centralbl. f. Bakteriolog. u. Parasitenk., iii. (1888) pp. 540–3.

† Zeitschr. f. Wiss. Mikr., v. (1888) pp. 55–6.

‡ Ibid., pp. 50–3.

remain for 16, 24, 48 hours without becoming brittle, and only being stained a yellowish-brown colour, except the myelin, which is almost black, the medullated fibres and their endings are clearly seen. The author says that he has had quite satisfactory results with Meissner's and Grandry's corpuscles. The objects fixed by the foregoing solution should be well soaked in water, and after-hardened in absolute alcohol.

The author also gives the following procedure for treating connective tissue formations with gold chloride. The objects are placed for two, three, or more hours in a 1 per cent. chloride solution, acidulated with hydrochloric acid (100:1). After having been washed they are placed in the dark in a 1/50-1/100 per cent. solution of chromic acid for reduction. Though reduction may not at this stage be perfect, it is completed later on in oil of cloves, and the preparation is then mounted in balsam. The more carefully the chromic acid is washed out the clearer the picture is. The non-medullated nerve-fibres and their ramifications are stained almost black. The connective tissue cells appear just as distinctly, while the intercellular substance of the connective tissue is unstained. Muscle-fibres, striped and unstriped, are stained a greenish-blue colour. The author states that this method is almost always certain.

**Phenol in Microscopical Technique.\***—When sections imbedded in paraffin curl up and are placed in turpentine oil it is found extremely difficult to flatten them without breaking them. This inconvenience, says Signor E. Aievoli, may be remedied in the following manner:—the sections are immersed for 15-30 minutes in benzine or turpentine oil, and are then transferred to pure fluid phenol, wherein the sections unroll themselves and come to the surface of the fluid. The carbolic acid does not damage the tissue structure, even if the sections be left in it for twenty-four hours. The sections are then treated in the usual manner.

The author found great advantage in staining tissues *en masse* with a carmine solution prepared in the following manner:—One grm. of carmine is dissolved in 100 ccm. of hot water, and then 7 grm. of powdered carbonate of soda are added. The solution is kept stirred for 30-40 minutes and filtered when cold. In this solution large pieces of tissue may be stained in twenty-four hours. They are then transferred to acidulated (1 per cent.) spirit for some hours. This method is stated to give stronger and clearer colouring to the nuclei than other carmine solutions. It is also especially suitable for tissues which have been fixed with sublimate or absolute alcohol.

**Double Staining.†**—Dr. J. H. List states that the double stains recommended by him for epithelia, glands, and cartilage have undergone the test of time, the preparations retaining the beauty of the stain after a lapse of four years. (For the original methods see this Journal, 1885, p. 902.) In his present note the author mentions again eosin-methyl-green for epithelium, glands, and cartilage, and hæmatoxylin-eosin for glands and retina. With this stain it is absolutely necessary that objects hardened in acids should be thoroughly washed to remove all traces of the acid, otherwise a precipitate may form on the preparation.

Bismarck brown (Weigert's formula) gave excellent results with Invertebrates (connective tissue of molluscs), and rosanilin nitrate was

\* Rivista Internaz. Med. e Chirurg. Napoli, iv. pp. 101-4.

† Zeitschr. f. Wiss. Mikr., v. (1888) pp. 53-4.

very effective for differentiating, for the nuclei of wandering leucocytes and for the mitoses in epithelia.

**Hardening and Staining Plate-cultivations.\***—Dr. E. Jacobi hardens and stains plate-cultivations by putting the plates in flat vessels and pouring over them a 1 per cent. solution of bichromate of potash, which is allowed to act for three days in the light. If the thin gelatin layer does not detach itself it can be easily removed with a knife. Then follows twenty-four hours' soaking in water and afterwards hardening in 50 per cent. and 70 per cent. spirit. From this small pieces of the gelatin, which are treated just like sections, are stained with Löffler's alkaline methylen-blue and afterwards washed in very dilute acetic acid, then placed in absolute alcohol, removed to the slide, where they are cleared up in xylol or in turpentine oil, and then mounted in Canada balsam. A leaden weight placed over the cover-glass serves to keep the specimen flat. Anilin-water-safranin or Gram's method may be used for staining. Experiments with agar plates were unsuccessful. Photographs obtained from these specimens coloured red or blue, the latter from orthochromatic plates, were satisfactory.

**Injection Mass for the Vessels of the Spleen.†**—Dr. H. Hoyer prepares a mass for injecting the vessels of the spleen in the following manner:—5 gm. of Berlin blue made up with oil (obtained from artists' colourmen in zinc tubes) are rubbed up in a mortar with 5 gm. of inspissated linseed oil. To this are then gradually added about 30 grams of some essential oil which is easily soluble in alcohol and has little action on the tissues round about the vessels (e.g. oil of lavender, fennel, thyme, rosemary) until a syrupy fluid is produced. It is then poured into a well-stoppered glass vessel and allowed to stand for twenty-four hours, when the supernatant fluid is poured off from the sediment. This blue fluid may then be preserved for an indefinite time, but if it has stood for a few days it is necessary to shake it up before using it. This must also be done if other than blue pigments be used, for example, chrome yellow, with which very satisfactory results are obtainable, the splenic capillaries appearing greyish-yellow by transmitted, bright yellow with reflected light.

The cannula is best filled with the injection mass by pouring the latter in at the end. Injection of the spleen must be carried out very slowly and at a very low pressure, and should be suspended when the surface arteries become visibly coloured, and if the venous side be injected when the whole organ shows the stain and before any actual swelling is observable. The preparation is then placed for twenty-four hours in strong spirit or absolute alcohol in order to dissolve the essential oil and to precipitate the pigment on the inner surface of the walls of the vessels. The organ may then be sectioned, stained, and mounted in the usual way.

This mass may be used for any other organ or tissue difficult of injection, as, for example, the marrow of bone.

**Injection with Indian Ink.‡**—Prof. K. Taguchi recommends, from nine years' experience, the use of Indian or Chinese ink for cold injections. The colouring matter is not affected by light or chemical

\* *Centrbl. f. Bakteriolog. u. Parasitenk.*, iii. (1888) pp. 536-8.

† *Internat. Monatschr. f. Anat. u. Physiol.*, iv. (1887) pp. 341-57.

‡ *Arch. f. Mikr. Anat.*, xxxi. (1888) pp. 565-7 (1 pl.).

action, the carbon particles do not change the tissues outside the vessels, the material adheres so firmly to the walls of the vessels that it does not flow out on the surface of sections, the preparations may be hardened in alcohol, chromic acid, &c., without losing colour, and they may be examined fresh in glycerin. The sections may be afterwards stained with any colour.

A medium quality of black ink is chosen, Japanese rather than Chinese; it is rubbed down in water till the fluid is such that when dropped on thin blotting-paper it coheres, and forms no grey ring round the drops. The mode of using the fluid is in no way peculiar. Until the preparation is hardened there must be no contact of the section with water. Some sections are figured to show the success of this injection.

**Beck's Microsyringe.\***—Prof. M. Flesch recommends Dr. G. Beck's apparatus for minute injection. It is a small syringe, the piston-rod of which is worked by a cog-wheel arrangement, and can consequently be used for aspiration as well as injection without a change of hands being necessary. It is so made that the cannula needle fits on quite flush, thus preventing the inclosure of air-bubbles. In the original form the cannula screwed on, but this has been found to be quite unnecessary. The graduation, marked on the piston-rod, is accurate enough to allow about 10 ccm. of a fluid to be injected at one time. The piston washer is made of felt and not of leather. As this material does not become hard when heated the syringe can be disinfected in an oil-bath at 150° C. without damage.

The syringe itself and the method of working it are shown in the illustration (fig. 157).

FIG. 157.

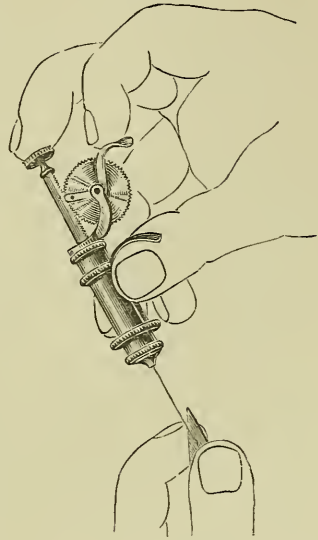

- BARÁNSKI, A.—Zur Färbung des Actinomyces. (On staining Actinomyces.)  
*Deutsch. Med. Wochenschr.*, 1887, p. 1065.
- DURDUFI, G. N.—Beitrag zur physiologischen Methylenblaufärbung. (Contribution to the physiological reaction of methyl-blue.)  
*Deutsch. Med. Wochenschr.*, XXVI. (1888) p. 518.
- GIESON, J. VAN.—The Brain-cortex stained by Golgi's method.  
*New York Med. Rec.*, XXXIII. (1887) p. 283.
- GÜNTHER.—Die schnellste Methode zur Färbung von Tuberkelbacillen. (The quickest method for staining tubercle bacilli.)  
*Wiener Klin. Wochenschr.*, 1888, pp. 292-3.
- NICKEL, E.—Die Farbenreactionen der Kohlenstoffverbindungen. 1. Farbenreactionen mit aromatischen Charakter. (The colour reactions of carbon combinations. I. Colour reactions of an aromatic character.)  
Inaugural diss., 42 pp. 8vo, Berlin, 1888.
- NOTT, T. E.—Staining of Tubercle Bacilli.  
*Atlanta Med. and Surg. Journ.*, 1888, pp. 200-2.

\* *Zeitschr. f. Wiss. Mikr.*, v. (1888) pp. 43-5 (1 fig.).

- TÄNZER, P.—Ueber die Unna'sche Färbungsmethode der elastischen Fasern der Haut. (On Unna's staining method for the elastic fibres of the skin.)  
*Monatsschr. f. Prak. Dermatol.*, VI. (1887) No. 9.
- UNGAR.—Ueber Färbung von Spermatozoen. (On staining spermatozoa.)  
*Verh. Naturhist. Vereins. Preuss. Rheinlande*, XLIII. (1887) SB. p. 303.
- UPSON, H. S.—Die Carminfärbung für Nervengewebe. (Carmine staining for nerve-tissue.)  
*Neurol. Centralbl.*, VIII. (1888) pp. 319 and 320.

(5) Mounting, including Slides, Preservative Fluids, &c.

**Continuous Centering of a Cover-glass.\***—The Rev. J. L. Zabriskie finds that a very satisfactory method for the continuous centering of a cover-glass, for subsequent operations with the self-centering turntable, with either a glycerin or a balsam mount, when no cell is employed, is to run a very delicate ring of india-ink with a fine pen upon the upper, or clean side of the glass slip, while the slip is revolving upon the turntable, and  $1/32$  in. larger than the cover about to be used, as the first step in the operation of mounting.

He has heard of such rings being employed on the under side of the slip. But very few of the latter are such accurate parallelograms that a ring on the under side will be central for the upper side, because, when the slip is turned over, it is liable to be held on the turntable by the pair of diagonal corners, which were not employed in the first instance. And moreover, when the ring is run on the under side the thickness of even a thin slip renders difficult the subsequent centering of a cover by sight.

If the ring of ink is run on the clean side of the slip it is accurately centered for each subsequent operation; the cover can be centered within it accurately without returning to the turntable, and if the application of a spring-clip causes the cover to slide, the latter can still be immediately readjusted by sight.

The india-ink dries at once, and does not, as might be supposed, cause any practical difficulty by running in under the cover-glass. In case of a glycerin mount, if there is excess of glycerin around the cover, a small stream of cold water, used to wash away the excess glycerin, also instantly carries away the ring of ink. If there is no excess of glycerin the ring of ink may be left, and it will be entirely hidden by the sealing of the mount, if any dark-coloured cement is used. In case of a balsam mount the ring of ink will be scraped away when cleaning the slide, or if there is no excess of balsam, it may be quickly removed, when the mount has hardened, by the moisture of the breath and gentle rubbing with a handkerchief.

**Steinach's Filter-capsule.†**—Dr. E. Steinach has devised an apparatus for aiding certain manipulations in microscopical technique. It is a glass filter-capsule, and consists of a small round pan 4 cm. high and 6 cm. in diam. (figs. 158 and 159). Its floor is about 2 to 3 mm. thick, is slightly deepened towards the centre, and perforated by numerous funnel-shaped holes, the small ends of which are uppermost. The holes in the bottom of the sieve may vary in size as required, but as usually made are just capable of allowing a fine needle to pass through (about  $1/2$  to 1 mm.). The sieves are of two kinds, according as they are supported on feet or not. The sieve or filter-capsule is placed within

\* Journ. New York Micr. Soc., iv. (1888) pp. 159-60.

† Zeitschr. f. Wiss. Mikr., iv. (1887) pp. 433-8 (2 figs.).

an outer pan which is supplied with a lid. This external glass capsule is of course somewhat larger than the inner or filter capsule, and its

FIG. 158.

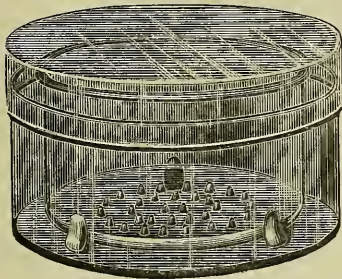

FIG. 159.



measurements are about 9 cm. in diam., and 6 cm. high. By means of this apparatus, preparations are washed, stained, decolorized or dehydrated, &c., by placing the section in the inner pan, and the fluid in the outer, and when the latter has acted sufficiently, the inner pan is merely lifted out, and having been allowed to drain is placed within another pan containing the next reagent and so on. When the reagent is expensive it is advisable to use the filter-capsule without legs. When required for removing all traces of acid from preparations, the apparatus is used as an irrigator.

Apparatus for inclosing microscopical preparations of botanical objects mounted in glycerin.\*—Dr. M. Kronfeld has devised an apparatus for facilitating the inclosure of preparations with turpentine resin when these preparations are mounted in glycerin and a square cover-glass is used. The tool used for laying on the resin is a triangular

FIG. 160.

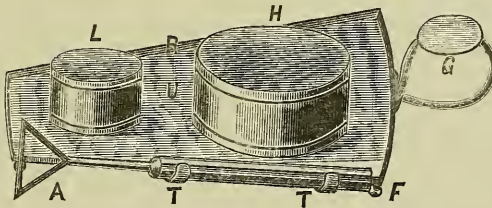

instrument made of wire. The resin is applied by heating the layer-on in the flame of a spirit-lamp or gas-jet, and it is to obviate the inconvenience of having the several apparatus required for this purpose in different places that he has brought them together.

U (fig. 160) is a tray resting on 4 feet F; its edges R are turned up and it is provided with a handle G. It carries two circular filletings in which the spirit-lamp L, and the resin-box H fit. On the side are two clips T T in which the laying-on tool A, with a wooden handle, rests.

\* Bot. Centralbl., xxxiv. (1888) pp. 345-6 (1 fig.).

The spirit-lamp is a metal box filled with tow, and covered with wire gauze.

**Preservation of Plants in Spirit and the Prevention of Browning.\***  
—Dr. H. de Vries describes the following methods for preserving vegetable tissues in spirit and for the prevention of browning.

As the cause of the browning must be sought in certain uncoloured matters present in the cell-juices, and which by oxidation become brown, it follows that the first object is to remove these substances from the preparations before they become oxidized. It has long been known that many leaves become less darkly coloured, if, before the death of the cell, the air be removed (by means of the air-pump or boiling).

Boiling in water and then placing the preparation afterwards in cold spirit frequently gives satisfactory results, e. g. in *Viscus albus*. An excellent method is to boil the parts of the plants in spirit. Leaves of rhododendron, *Viscus*, *Aucuba*, which are only immersed for five minutes in boiling spirit, become quite decolorized afterwards, a result which, at any rate in *Aucuba*, can be attained in no other way.

Another method which, with the exception of *Aucuba*, gave excellent results, is to kill the plants in spirit to which about 2 per cent. hydrochloric, sulphuric, or acetic acid has been added. The preparations are kept in this fluid for several months and then transferred to spirit without acid. This is removed from time to time until all the colouring matter has been removed. The long stay in the acid fluid does not at all injure the plants as they are just as useful for microscopical purposes as fresh or otherwise preserved organs. Even the crystals of oxalate of lime are not dissolved by the mixture of spirit and hydrochloric acid, although they are when the acid is mixed with water. In this way completely decolorized preparations of *Monotropa* and *Orobanche* can be obtained, and this fluid will also prevent *Boletus* from becoming blue.

As the oxidation products are partly insoluble in acid alcohol, organs do not become thoroughly decolorized by the fluid; thus the bracts of *Plantago lanceolata* retain their colour, and in unripe fruits the places where the flowering parts were attached can still be recognized, because these parts were dead before they came into the acid spirit.

The decoloration of preparations which have already become brown can only be effected by oxidation. The most effective reagents for this purpose are chlorate of potash or soda with sulphuric acid. This completely or almost completely removes the browning. The preparations are placed in spirit to which 0.2–0.5 ccm. per cent. of strong sulphuric acid and a small quantity of chlorate of potash crystals are added. If the vessel be shaken from time to time, oxidation will be completed in 6 to 8 days; any trace of pigment left after this time will always be unaffected by the solution. The preparations are then transferred to spirit.

Another method of preservation consists in the use of a one per cent. solution of picric acid. The preparations, however, become stained yellow and always remain flabby, but as the chlorophyll is unaltered by the solution, it is very useful for preserving variegated flowers. Spirit through which sulphurous acid has been passed until a large quantity has been taken up gives satisfactory results. Pure glycerin is not

\* Maandblad van Natuurwetenschappen, 1886, Nos. 1, 5, and 6, 1887, No. 4. Handelingen van het eerste Natuur- en Geneeskundig Congres te Amsterdam, 1887, p. 139. See this Journal, 1887, p. 675; 1886, p. 1075.

recommended for preserving the coloured parts of plants, as the dyes are given off after the lapse of a few months.

The author then discusses the brittleness which affects plants which have been long kept in strong spirit. This brittleness may be prevented by soaking the parts in water until they become quite flaccid and then placing them in spirit. As the results of his examination into the cause of this brittleness, the author finds that when the tinged parts of a plant are killed by immersion in spirit, their death is effected before the tension of different parts has had time to become equalized. Hence this tension is "fixed" by the spirit and becomes the cause of the brittleness. Water, however, equalizes the tension of the various parts, and hence removes the brittleness by rendering the tissue elastic.

**Fixing Sections to the Slide.\***—Mayer's albumen fixative, says Mr. J. Nelson, is absolutely reliable for fixing sections to the slide, and should be used whenever sections are loosely coherent in their parts. Neat results with this can only be obtained with a very thin and even film, to secure which proceed as follows:—A small drop of the fixative is spread on the slide with the ball of the index finger. Excess of fixative is removed by wiping the finger dry, and continuing the rubbing until no frothy streaks appear in the film. Then tap the moist surface lightly with the finger, so that by light reflected at a proper angle it appears finely stippled. Each section is pressed into the film with a brush, and when the slide is full, a piece of filter paper is placed over all, and pressed firmly with the finger until every part of each section is in even contact with the glass. Then heat the slide over steam until the paraffin melts, and then plunge into turpentine. The film is opaque in alcohol, but this is corrected in turpentine and mounting. Should the presence of the foreign albumen in the sections be undesirable, recourse should be had to Gaule's alcoholic fixative. It is a means whereby the albumen molecules of the section are brought into the same adhesive contact with the glass as those of ordinary fixatives. The slide is brushed over with 40–70 per cent. spirit, and when this film has evaporated, thin sections stick closely. Superfluous spirit is removed with bibulous paper, and the slide then evaporated to dryness; this is best done in a thermostat at 40° C. for 1–2 hours. The paraffin should never be allowed to melt. It is removed with turpentine as for other fixatives. Celloidin sections stick well with this method.

VOJNOFF, R. G.—On the different Cements for closing microscopical sections.

*Ejened. Klin. Gaz. St. Petersburg*, VII. (1887) p. 411 (Russian).

WOJNOFF, K.—Einige Bemerkungen betreffend das Festkleben mikroskopischer Schnitte auf Objectträger. (Some remarks on fixing microscopical sections to the slide.)

*Klin. Wochenschr.*, 1887, 6 pp.

#### (6) Miscellaneous.

**Methods of Plastic Reconstruction.†**—Prof. H. Strasser writes at great length and in copious detail on methods of reconstructing the object. All he has to say is practically a recapitulation of Born's procedure for making wax plates upon which the image of the object is drawn. The outline is then cut out, and the various plates are united together in their proper order, and this done the edges are smoothed off so that an enlarged solid copy of the original object is obtained. For

\* *American Naturalist*, xxii. (1888) p. 664.

† *Zeitschr. f. Wiss. Mikr.*, iv. (1887) pp. 168–209, 330–9.

this purpose wax is melted and poured out on a piece of plate glass, and this sheet of wax is rolled level with an iron roller. The wax sheets may be simple, or laid on paper which has been previously saturated with wax, and the roller used may be hot or cold according as the wax is softer or harder. Instead of glass a lithographic stone is recommended.

**Making Mounts Photographic.\***—Mr. G. W. Rafter writes that there is a phase of mounting which could well be impressed upon the attention of microscopists. That is, to make all mounts with reference not merely to use under the tube, but with reference to good photographic results. He thinks he is justified by experience and study in saying what has been well said before, that whatever can be seen with an objective and eye-piece can be photographed as clearly as it can be seen, provided proper methods of preparation for photography are followed. He thinks it may be further stated that such methods of preparation will not diminish their value under the tube. "Go through a cabinet of ordinary mounts and see how few are photographable! The enormity of the thing appears when we consider that nearly all classes of mounts, including opaque, may be readily photographed if properly prepared. To this, however, there are a few exceptions. The additions to general knowledge of matters microscopic which could be made, if all working microscopists would prepare with reference to photography is simply enormous."

**Improved method for Enumerating Blood-corpuscles.†**—M. Mayet has made a further improvement in artificial serum used in the enumeration of blood-corpuscles. Blood to the volume of 4 mm. is first mixed with 500 mm. of a watery 1 per cent. solution of osmic acid by which the corpuscles are fixed and rendered colourable. At the end of three minutes 500 mm. of the following liquid is added:—Glycerin, 45 ccm.; distilled water, 55 ccm.; cosin in aqueous 1 per cent. solution, 17 ccm. The red corpuscles are brightly stained, the leucocytes being scarcely or not at all coloured, and this difference of tint allows the two kinds of corpuscles to be easily counted. The distribution of the corpuscles on the slide is quite uniform, owing to the fact that the mean density of the two fluids used for dilution is equal to about 1084, and also to the viscosity of the glycerin. The further steps in the procedure are as heretofore.

**Improved method for the Bacteriological Examination of Air.‡**—The method adopted by MM. Straus and Wurtz for passing air through fluidified gelatin consists in transmitting the air through a tube contracted at the end, whereby fine bubbles are produced. Frothing is prevented by adding a drop of sterilized oil to the gelatin. The apparatus consists of a glass tube closed at the lower end and measuring 40 mm. broad by 20 cm. high. The diameter of the lower part is reduced to 15 mm., and herein 10 cm. of gelatin are placed. In the upper end, also contracted, is inserted a glass tube, the end of which reaches right to the bottom, and is there much reduced in size. Through this tube the air passes, and those germs which are not caught up by the gelatin are entangled in sterilized cotton-wool, a plug of which is placed

\* Amer. Mon. Micr. Journ., ix. (1888) pp. 77-8.

† Comptes Rendus, cvi. (1888) pp. 1553-9.

‡ Ann. Institut. Pasteur, 1888, p. 171.

around the inner tube at the top of the outer one. The wool is then shaken up in the gelatin, which afterwards may be removed by the inner tube and spread out on plates, or it may be rolled out on the inside of the large tube. The entrance of air is very quick, 50 litres in 15 minutes.

**Gelatin Culture Test for Micro-organisms of Water.\***—Dr. C. Smart concludes an extensive consideration of the micro-organisms of water with the following remarks in reference to the gelatin culture test, which he believes to be valuable only in its doubtful promise for the future: "At present," he says, "in the hands of the sanitary inquirer, it gives but little information, and that little is surrounded on all sides by interrogation points. In the laboratory of the scientific investigator, new methods may be discovered by which pathogenetic germs may be isolated and identified; but until that time arrives the sanitary analyst must depend upon the chemical results as translated in each particular instance by the aid of the ascertained sanitary environment of the water, and however much he may cultivate the microbes, he should not forget to inspect that other field of microscopic life (*Nostoc*, *Kerona*, *Algæ*, &c.) to which reference was made at the beginning of this paper."

**Illustrations of Pond Life.**—The following paragraph appears in the 'Times' report of the 12th September of the soirée of the British Association at Bath:—

"At the soirée there were a large number of Microscopes and illustrations of the vegetable and animal kingdoms, and of histology, but the greatest novelty, which quite surprised most of the company, was a new method of illustrating pond life. Three sides of a long room were occupied with what are called transparencies. Brown paper is stretched on frames. Pieces are cut out of the brown paper corresponding with the size of the illustrations, which are painted on tissue paper. Behind the long row of these illustrations there are rows of gas-jets, and the strong light passing through the tissue paper made the objects distinctly visible at a long distance. The naturalists from other parts of the country quite envied the Bath and Bristol societies for the success they had attained in devising such a method of illustration, and carrying it out so efficiently."

Microscopists will recognize the method as that originally devised by Dr. Hudson, the President of this Society, to exhibit his drawings of Rotifers.†

BROWN, F. W.—A course in *Animal Histology*. III. Blood. IV. The Connective Tissues—Endothelium.

*The Microscope*, VIII. (1888) pp. 177-80 (1 fig.), 201-3, 244-6.

EWICH.—Ein Beitrag zur Fleischschau und Fleischkunde. (A contribution to the examination and knowledge of meat.) Svo, Osterwieck, 1888.

FREEBORN, G. C.—Notice of new Methods. V.

*Amer. Mon. Micr. Journ.*, IX. (1888) pp. 130-2.

HENSOLDT, H.—The Microscopical Investigation of Rocks. A plea for the study of Petrology.

*Journ. N. York Micr. Soc.*, IV. (1888) pp. 139-44.

\* *The Microscope*, viii. (1888) p. 215, from 'Philad. Med. News.'

† The 'Athenæum' of 15th September refers to them as "representing microscopic insect life from its lowest to its highest forms (!). They had been prepared by Dr. Hudson, of Clifton, who also described them verbally."

- HESSE, W.—Zur quantitativen Bestimmung der Keime in Flüssigkeiten. (On the quantitative determination of germs in fluids).  
*Zeitschr. f. Hygiene*, IV. (1888) p. 22.
- KCHNE, H.—Praktische Anleitung zum mikroskopischen Nachweis der Bacterien im thierischen Gewebe. (Practical guide to the microscopical demonstration of Bacteria in animal tissue.) vi. and 44 pp., Svo, Leipzig, 1888.
- MANTON, W. P.—Rudiments of Practical Embryology.  
[Staining—Infiltrating the paper cell—Section-cutting—Preparation of slides—Mounting.] *The Microscope*, VIII. (1888) pp. 180-1, 203-6 (3 figs).
- MIQUEL, P.—De la valeur relative des procédés employés pour l'analyse micrographique des eaux. (On the relative value of the processes employed for the microscopical analysis of water.) *Revue d'Hygiène*, 1888, pp. 391-406.
- NIKIFOROFF, M.—Kurze Studien in der mikroskopischen Technik. (Short studies in microscopical technique.) 169 pp., 16mo, Moscow, 1888.
- OSBORN, H. L.—Studies for Beginners. III. The Vinegar Eel.  
*Amer. Mon. Micr. Journ.*, IX. (1888) pp. 121-3.
- STRENG, A.—Ueber einige mikroskopisch-chemische Reaktionen. (On some microchemical reactions.)  
*Neues Jahrb. f. Mineral., Geol., Palæontol.*, 1888, pp. 142-50 (3 figs.).
- TINDALL, S. J.—Scales on Red Currants.  
[“A very beautiful object for the Polariscope.”] *Sci.-Gossip*, 1888, p. 187.
- TROUP, F.—The Diagnosis of early Phthisis by the Microscope.  
*Edinburgh Med. Journ.*, 1888, pp. 1-7.
- WATERMAN, S.—How to produce Hæmoglobin or Hæmatocrystallin.  
*The Microscope*, VIII. (1888) pp. 165-171 (1 pl.).
- WENDE, E.—[The Microscope in the Diagnosis of Skin Diseases.]  
*The Microscope*, VIII. (1888) p. 217, from *Med. Press of West. New York*.
- WHELPLEY, H. M.—Microscopy for Amateur Workers.  
[Recommendation of vegetable histology and morphology for amateurs.]  
*The Microscope*, VIII. (1888) pp. 195-8.
-

## PROCEEDINGS OF THE SOCIETY.

THE first Conversazione of the Session was held on the 23rd November, 1887.

The following objects, &c., were exhibited :—

Mr. J. Badcock:

*Carchesium polypinum.*

Mr. C. Baker:

(1) Bacteriological Microscope with 1/2 in. homogeneous-immersion and Abbe condenser. (2) Nelson Model Microscope, with differential screw fine-adjustment specially adapted for photomicrography. (3) New Microscope Stands by Zeiss with Iris Diaphragm to Abbe condenser. (4) Podura scale  $\times$  500 under Zeiss apochromatic 4.0 mm. objective N.A. 0.95. (5) *Triceratium favus*  $\times$  300 under Zeiss CC (1/4 in.) objective and Abbe condenser, dark ground illumination. (6) *Aulacodiscus Stoschii* and *A. formosus*, under Zeiss apochromatic 16.0 mm. objective and Abbe condenser; dark ground illumination.

Messrs. R. and J. Beck:

(1) *Spirillum* under new 1/12 oil-immersion. (2) Podura Scale under cheap 1/4 in. with 4th eye-piece.

Mr. Bolton:

*Dendrosoma radians.*

Mr. E. T. Browne:

*Orthesia cataphracta* and *O. insignis.*

Mr. Crisp:

Dellebarre Microscope.

Prof. Crookshank:

Demonstration of specimens in the new Bacteriological Laboratory, and projection of Photographs of Bacteria upon screen with Oxyhydrogen Lantern.

Mr. Dadswell:

(1) Cyclosis in bulbil of *Lychnothammus stelliger.* (2) *Epistylis.*  
(3) *Amœba princeps.*

Mr. F. Enoch:

(1) The Hessian Fly, *Cecidomyia destructor* Say. (2) Parasite of ditto, *Semioteilus destructor* Say. (3) Head of Devil's Coach-horse, *Oxyypus oleus.*

Mr. F. Fitch:

Dissection of Garden Spider, *Epeira diadema.*

Mr. H. E. Freeman:

(1) Serial sections of Spiders prepared by Mr. H. M. Underhill.  
(2) Sections of Eyes of Butterfly (*Pieris brassicæ*).

Prof. Groves:

Continuity of Protoplasm between the cells of a medullary ray in internodes of species of *Nerium* (Oleander) and *Helianthus annuus* (Sunflower).

Mr. H. F. Hailes:

Foraminifera from Davis' Straits.

Mr. J. D. Hardy :

Zoophytes, &c., chiefly from Weymouth.

Mr. J. E. Ingpen :

*Vallisneria*.

Mr. S. J. McIntiro :

Larva of *Tiresias scarra*, the insect whence the hairs formerly known as "Hairs of Dermestes" are obtained.

Mr. R. Macer :

*Musca domestica*, showing eyes, proboscis, &c., by the exhibitor's special apparatus.

Mr. A. D. Michael :

*Anelasmacephalus Cambridgei*.

Dr. J. Millar :

*Coltosphaeræ* n. sp.

Mr. E. M. Nelson :

(1) Photomicrographic negative of *Amphipleura pellucida* taken by Zeiss apochromatic 1/8 in., N.A. 1.42, and projection eye-piece;  $\times$  730 diam. (2) Ditto of *Coscinodiscus asteromphalus*;  $\times$  550 diam. (3) *Amphipleura pellucida*, Powell and Lealand homogeneous-immersion 1/12 in., 1.43 N.A.; achromatic compensating eye-piece;  $\times$  1300. Powell and Lealand achromatic oil-immersion condenser. Intensified by a Nicol analyser.

Messrs. Newton and Sons :

Electrical Polarization Microscope.

Mr. G. D. Plomer :

(1) *Spongilla fluviatilis*. (2) Larva of *Corethra plumicornis*.

Messrs. Powell and Lealand :

(1) *Amphipleura pellucida* with apochromatic homogeneous-immersion 1/12 in. and achromatic oil-immersion condenser. (2) *Pleurosigma angulatum* with 1/30 in. water-immersion and achromatic condenser.

Mr. B. W. Priest :

(1) Diatoms from Arafura Sea. (2) Surface organisms, Faroo Channel.

Mr. C. W. Rousselot :

*Floscularia ornata*.

Mr. G. J. Smith :

(1) Fungus (with sporangia) in Shelly Purbeck Limestone, Durlstone Bay, Swanage. (2) "Flint" from the Purbeck with valves of Entomostraca, Durlstone Bay. (3) Section of Fish-tooth in Purbeck Limestone, Durlstone Bay. (4) Fragment of Corroded Quartz in Basalt, the Weilberg, Nassau. (5) Dolerite, Rossell Hill, I. of Mull.

Prof. C. Stewart :

Shell of *Galathea strigosa*.

Mr. A. W. Stokes :

Peristome of Moss (*Funaria hygrometrica*).

Mr. W. T. Suffolk :

*Drosera rotundifolia*, glandular hair.

Messrs. W. Watson and Sons :

(1) Group of Eggs of Butterflies, Moths, &c. (2) Type slide of Diatoms from Oamaru—88 species. (3) Type slide of Holothuridæ. (4) Type slide of Spines of *Echini*. (5) Lungs and ovipositor

of Spider. (6) Section through bud of *Lilium candidum*, showing Ovary, Anthers, Pollen-grains, Petals, &c.

Mr. T. Charters White :

Album of Photomicrographs.

The second Conversazione of the Session was held on the 25th April, 1888.

The following objects, &c., were exhibited :—

Mr. Badcock :

(1) Fresh-water Polyzoa. (2) *Lophopus cristallinus*. (3) Rotifers, &c.

Rev. G. Bailey :

Foraminifera from the Red Chalk.

Mr. J. W. Bailey :

Dr. Kibbler's Photo-Microscope.

Mr. C. Baker :

(1) Model of proposed form of Mayall removable mechanical stage giving 1 inch vertical and horizontal movements. (2) Large Nelson model Microscope specially adapted for photomicrography, and having differential screw fine-adjustment to substage.

Mr. F. G. Bernau :

(1) *Bacillus anthracis* (kidney). (2) Plant bug, Ceylon.

Mr. Bolton :

*Volvox globator*.

Mr. E. T. Browne :

Pollen of *Gætha Makoyana*.

Mr. H. Burns :

Nests of Living Ants.

Mr. Crisp :

Adams' Projection and Compound Microscope.

Mr. E. Dadswell :

*Volvox* showing cilia.

Mr. F. Enoch :

*Salticus tardigradus* showing the 8 eyes. Various Insect preparations and drawings.

Mr. F. Fitch :

(1) Rectal valve of Blow-fly covered and uncovered. (2) Rectal papillæ of Blow-fly covered and uncovered.

Mr. W. Godden :

Foraminifera from London Clay.

Mr. R. T. Lewis :

*Stentors*, *Vorticellæ*, and *Callidina*.

Mr. J. W. Lovibond :

New instrument for measuring pigmentary colours.

Mr. A. D. Michael :

Female reproductive organs of *Cepheus latus* (Oribatidæ).

Messrs. Powell and Lealand :

*Amphipleura pellucida* with apochromatic homogeneous-immersion 1/12 in., N.A. 1.4, and achromatic oil-immersion condenser, N.A. 1.4.

- Mr. B. W. Priest:  
Fossil spicules from deposit, Jackson's Paddock, Oamaru.
- Mr. H. B. Robinson:  
Hairs (human), long and transverse section.
- Mr. T. B. Rosseter:  
*Stephanoceros Eichhornii*.
- Mr. C. Rousselet:  
Free-swimming Rotifers.
- Mr. G. J. Smith:  
(1) Gabbro, Penig, Saxony. (2) Dolerite (Tertiary) Crawfordjohn, Lanarkshire. (3) Twin Crystals of Augite. (4) Granite, Cheesewring Quarry, Cornwall.
- Mr. J. H. Steward:  
(1) Moving sand from the Diamond Fields, Brazil. (2) Platinocyanide of Cerium.
- Prof. C. Stewart:  
Stridulating Organs of *Lomaptera yorkiana*.
- Mr. A. W. Stokes:  
Diffraction spectra by means of photograph of grating 3000 lines to inch.
- Mr. A. Topping:  
Insect preparations.
- Mr. J. J. Vezey:  
Longitudinal section of Embryo in grain of Maize.
- Messrs. W. Watson and Sons:  
(1) Hand of Human Embryo, 2 months, showing commencement of ossification in metacarpal bones. (2) Group of Eggs of Butterflies, Moths, &c. (3) Head of *Cysticercus* from Hare.
- Mr. C. West:  
(1) *Lagena spiralis* n. sp., Macassar Straits. (2) *Technitella melo* Norman, Cebu, Philippines.
- Mr. W. West:  
(1) Ovaries of House Fly. (2) Wing of Moth infested with parasites.
- Mr. G. Western:  
Free-swimming Rotifers.
- Mr. T. Charters White:  
Photomicrographs.
-

1888. Part 6.

DECEMBER.

{ To Non-Fellows,  
Price 5s.

JOURNAL  
OF THE  
ROYAL  
MICROSCOPICAL SOCIETY;

CONTAINING ITS TRANSACTIONS AND PROCEEDINGS,  
AND A SUMMARY OF CURRENT RESEARCHES RELATING TO  
ZOOLOGY AND BOTANY  
(principally Invertebrata and Cryptogamia),  
MICROSCOPY, &c.

*Edited by*

**FRANK CRISP, LL.B., B.A.,**

*One of the Secretaries of the Society*

*and a Vice-President and Treasurer of the Linnean Society of London;*

WITH THE ASSISTANCE OF THE PUBLICATION COMMITTEE AND

**A. W. BENNETT, M.A., B.Sc., F.L.S.,**

*Lecturer on Botany at St. Thomas's Hospital,*

**F. JEFFREY BELL, M.A., F.Z.S.,**

*Professor of Comparative Anatomy in King's College,*

**JOHN MAYALL, JUN., F.Z.S.,**

**R. G. HEBB, M.A., M.D. (Cantab.),**

AND

**J. ARTHUR THOMSON, M.A.,**

*Lecturer on Zoology in the School of Medicine, Edinburgh,*

FELLOWS OF THE SOCIETY.



WILLIAMS & NORGATE,  
LONDON AND EDINBURGH.

# CONTENTS.

TRANSACTIONS OF THE SOCIETY—

PAGE

XI.—A REVISION OF THE GENUS <i>AULISCUS</i> ERHB, AND OF SOME ALLIED GENERA. By JOHN RATTRAY, M.A., B.Sc., F.R.S. (Plates XII.—XVI.) .. .. .	861
XII.—NOTE ON THE LARGE SIZE OF THE SPICULES OF <i>ACIS ORIENTALIS</i> . By F. JEFFREY BELL, M.A., Sec. R.M.S. .. .. .	921

## SUMMARY OF CURRENT RESEARCHES.

### ZOOLOGY.

#### A. VERTEBRATA:—Embryology, Histology, and General.

##### a. Embryology.

VIRCHOW, H.— <i>Physics of the Yolk</i> .. .. .	923
ROUX, W.— <i>Embryonic Axis</i> .. .. .	923
SANFELICE, F.— <i>Sperm Atogenesis of Vertebrates</i> .. .. .	923
PRENANT, A.— <i>Spermatogenesis of Reptiles</i> .. .. .	924
SIDEBOTHAM, H.— <i>Fate of the Blastopore in Rana temporaria</i> .. .. .	925
MARSHALL, A. MILNES.— <i>Development of the Froy</i> .. .. .	925
CLARKE, S. F.— <i>Eggs of Alligator lucius</i> .. .. .	925
RAFFALLE, F.— <i>Eggs and Larvæ of Teleosteans</i> .. .. .	925
WEISMANN, A.— <i>Heredity</i> .. .. .	926
KHAWKINE, M. W.— <i>Principle of Heredity and the Laws of Mechanics applied to the Morphology of Sol tary Cells</i> .. .. .	926
THOMSON, J. A.— <i>Action of the Environment</i> .. .. .	927
MORGAN, C. LLOYD.— <i>Elimination and Selection</i> .. .. .	927

##### b. Histology.

CIANCI, C., & G. ANGIOLELLA.— <i>Structure of Red Blood-corpuscles</i> .. .. .	928
RABL-RÜCKHARD, H.— <i>Peculiar Fat-cells</i> .. .. .	928
WALDEYER, W.— <i>Karyokinesis in its Relation to Fertilization</i> .. .. .	928
MINGAZZINI, P.— <i>Reticulum of Muscle-fibre</i> .. .. .	928
SCHNEIDER, A.— <i>Sarcolemma</i> .. .. .	928
ROUDE, E.— <i>Nervous System of Amphioxus</i> .. .. .	929

#### B. INVERTEBRATA.

CHATIN, J.— <i>Myelocytes of Invertebrates</i> .. .. .	929
DUBOIS, R.— <i>Role of Symbiosis in Luminous Marine Animals</i> .. .. .	929
ZACHARIAS, O.— <i>Distribution by Birds</i> .. .. .	930

##### Mollusca.

##### a. Cephalopoda.

GIGANTIC Cephalopoda .. .. .	930
WATASE, S.— <i>Germinal Layers in Cephalopods</i> .. .. .	931
JATTA, G.— <i>Olfactory Ganglia of Cephalopods</i> .. .. .	931
WEISS, F. E.— <i>Some Oligopsid Cuttle-fishes</i> .. .. .	931
LAURIE, M.— <i>Organ of Verrill in Loligo</i> .. .. .	932
GRIFFITHS, A. B.— <i>Salivary Glands of Sepia officinulis and Patella vulgata</i> .. .. .	932

##### γ. Gastropoda.

PRENANT, A.— <i>Spermatogenesis of Gastropods</i> .. .. .	932
PELSENER, P.— <i>Classification of Gastropoda by the Characters of the Nervous System</i> .. .. .	933
GARNAULT, P.— <i>Structure and Development of Egg in Chitonidæ</i> .. .. .	933
PLATE, L.— <i>Organization of Dentalium</i> .. .. .	933

##### δ. Lamellibranchiata.

BLANCHARD, R.— <i>Structure of Muscles of Lamellibranchiata</i> .. .. .	935
REICHEL, L.— <i>Formation of Byssus</i> .. .. .	935

##### Molluscoïda.

##### β. Bryozoa.

JULLIEN, J.— <i>Movements of Polypides in Zoecia of Bryozoa</i> .. .. .	936
VIGELIUS, W. J.— <i>Ontogeny of Marine Bryozoa</i> .. .. .	936
JULLIEN, J.— <i>Cristatella mucedo</i> .. .. .	936
JOYEUX-LAFFEUE, J.— <i>Delagia Chætopteri</i> .. .. .	936
BRAEM, F.— <i>Fresh-water Bryozoa</i> .. .. .	937

## Arthropoda.

	PAGE
PATFEN, W.— <i>Eyes of Arthropods</i> .. .. .	938
GILSON, G.— <i>Spermatogenesis of Arthropods</i> .. .. .	940
GEHUCHTEN, A. V.— <i>Striped Muscle of Arthropods</i> .. .. .	941

## a. Insecta.

GRABER, V.— <i>Primary Segmentation of the Germ-stripe of Insects</i> .. .. .	941
NUSBAUM, J.— <i>Germinal Layers of Meloe</i> .. .. .	942
PLANTA, A. V.— <i>Nutrient Food-Material of Bees</i> .. .. .	942
GILSON, G.— <i>Odoriferous Glands of Blaps</i> .. .. .	943
CASAGRANDE, D.— <i>Alimentary Canal in Metamorphosis</i> .. .. .	943
CHATIN, J.— <i>Nerve-terminations in Lepidoptera</i> .. .. .	943
REUTER, E.— <i>Basal Spot on Palps of Butterflies</i> .. .. .	943
BÜTSCHLI, O.— <i>Development of Musca</i> .. .. .	944
BRANDT, E.— <i>Larva of Sarcophila Wohlfartii in Gum of Man</i> .. .. .	944
CUCCATI, G.— <i>Brain of Somomya</i> .. .. .	944

## β. Myriopoda.

GAZAGNAIRE, J.— <i>Phosphorescence in Myriopoda</i> .. .. .	945
---	-----

## δ. Arachnida.

M'COOK, H. C.— <i>Relations of Structure and Function to Colour Changes in Spiders</i> .. .. .	945
FAUSSEK, V.— <i>Development of Generative Organs in Arachnida</i> .. .. .	946
WAGNER, V.— <i>Blood of Spiders</i> .. .. .	946

## e. Crustacea.

STAMATI, G.— <i>Castration of the Cray-fish</i> .. .. .	947
"   " <i>Digestion in Cray-fishes</i> .. .. .	947
BIEDERMANN, W.— <i>Innervation of Crabs' Claws</i> .. .. .	947
BATE, C. SPENCE— <i>'Challenger' Crustacea Macrura</i> .. .. .	948
ROSENSTADT, B.— <i>Structure of Asellus</i> .. .. .	948
BARROIS, T.— <i>Sexual Dimorphism in Amphipoda</i> .. .. .	949
PEREYASLAWZEWA, SOPHIE— <i>Development of Gammarus</i> .. .. .	949
EYLMANN, E.— <i>European Daphniæ</i> .. .. .	949
CHEVREUX, E.— <i>Orchestia</i> .. .. .	949
CATTANEO, G.— <i>Amæbocytes of Crustacea</i> .. .. .	949

## Vermes.

## a. Annelida.

APÁTHY, S.— <i>External Morphology of Hirudinea</i> .. .. .	950
HEYMANN, J. F.— <i>Nerve-endings in the Leech</i> .. .. .	952
FRIEDLÄNDER, B.— <i>Creeping Movements of Earthworm</i> .. .. .	952
BERGH, R. S.— <i>Excretory Organs of Criodrilus</i> .. .. .	953

## β. Nematelminthes.

LAMEERE, A.— <i>Abnormal Ova of Ascaris megaloccephala</i> .. .. .	953
WILLOT— <i>Heterodera Schachtii</i> .. .. .	953

## γ. Platyhelminthes.

HOYLE, W. E.— <i>General Sketch of the Trematoda</i> .. .. .	953
VOELTZKOW, A.— <i>Aspidogaster conchicola</i> .. .. .	954
BRANDES, G.— <i>Holostomum</i> .. .. .	954
BRANDT, E.— <i>Tænia cucumerina in Man</i> .. .. .	955
TUCKERMAN, F.— <i>Tænia saginata</i> .. .. .	955

## δ. Incertæ Sedis.

COSMOVICI, L. C.— <i>Contractile Vesicle of Rotifers</i> .. .. .	955
WELDON, W. F. R.— <i>Haplodiscus piger</i> .. .. .	955

## Echinodermata.

SARASIN, P. & F.— <i>Anatomy of Echinothurida and Phylogeny of Echinodermata</i> .. .. .	956
GRIFFITHS, A. B.— <i>Renal Organs of Star-fishes</i> .. .. .	958
CUÉNOT, L.— <i>Anatomy of Ophiurids</i> .. .. .	958
BARROIS, J.— <i>Development of Comatula</i> .. .. .	960
CARPENTER, P. H.— <i>'Challenger' Comatulæ</i> .. .. .	962

## Cœlenterata.

KOROTNEFF, A. DE— <i>Development of Hydriæ</i> .. .. .	963
KOCH, G. V.— <i>Flabellum</i> .. .. .	963
HICKSON, S. J.— <i>Sexual Cells and Early Stages in Development of Millepora plicata</i> .. .. .	964
HADDON, A. C.— <i>Larval Actinæ parasitic on Hydromedusæ</i> .. .. .	965
FISCHER, P.— <i>Scyphistomata of Acraspedote Medusæ</i> .. .. .	965
HERTWIG, R.— <i>Supplementary Report on 'Challenger' Actiniaria</i> .. .. .	965

	PAGE
NASSONOFF— <i>Boring Clionids</i> .. .. .	965
FIEDLER, K.— <i>Formation of Ova and Spermatozoa in Spongilla fluviatilis</i> .. .. .	965
PRIEST, B. W.— <i>Remarkable Spicules from the Oamaru Deposit</i> .. .. .	967

### Protozoa.

BÜTSCHLI, O.— <i>Phylogeny of Protozoa</i> .. .. .	967
GRUBER, A.— <i>Notes on Protozoa</i> .. .. .	969
RHUMBLER, L.— <i>Various Cyst-formations and Developmental History of Colpoda</i> ..	969
CLARK, J.— <i>Ciliary Movement</i> .. .. .	971
CATTANEO, G.— <i>New Parasitic Ciliated Infusorian</i> .. .. .	971
MASKELL, W. M.— <i>Fresh-water Infusoria of Wellington District, New Zealand</i> ..	972
GARCIN, A. G.— <i>Euglena</i> .. .. .	972
BRUYNE, C. DE— <i>New Monad, Endobiella Bambekii</i> .. .. .	972
BLANCHARD, R.— <i>Monas Dunali</i> .. .. .	973
PLATE, L.— <i>Asellioola digitata</i> .. .. .	973
"   " <i>Acinetoides</i> .. .. .	974
GRASSI, B.— <i>Parasitic Protozoa</i> .. .. .	975
SCHUBERG, A.— <i>Protozoa found in the Stomach of Ruminants</i> .. .. .	975
BEDDARD, F. E.— <i>New Gregarine</i> .. .. .	977

## BOTANY.

### A. GENERAL, including the Anatomy and Physiology of the Phanerogamia.

#### a. Anatomy.

##### (1) Cell-structure and Protoplasm.

STRASBURGER, E.— <i>Division of the Nucleus and of the Cell</i> .. .. .	978
FROMMANN, C.— <i>Properties and Changes of the Membrane, Protoplasm, and Nucleus of Plant-cells</i> .. .. .	980
WENT, F. A. T. C.— <i>Increase of Normal Vacuoles by Division</i> .. .. .	981
WIESNER, J.— <i>Albumen in the Cell-wall</i> .. .. .	982

##### (2) Other Cell-contents (including Secretions).

RENDEL, A. B.— <i>Development of Aleurone-grains in the Lupin</i> .. .. .	982
"   " <i>Occurrence of Starch in the Onion</i> .. .. .	983
BELLUCCI, G.— <i>Formation of Starch in the Chlorophyll-grains</i> .. .. .	983
"   " <i>Reserve-substances in Evergreen Leaves</i> .. .. .	983
FISCHER, A.— <i>Glucose as a Reserve-material in Woody Plants</i> .. .. .	984
LUNDSTRÖM, A. N.— <i>Colourless Oil-plastids in Potamogeton</i> .. .. .	984
HÖHNEL, F. V.— <i>Substance of which Gum-arabic is formed</i> .. .. .	984
MOELLER, H.— <i>Tannin and its connection with Metastasis</i> .. .. .	984

##### (3) Structure of Tissues.

LIGNIER, O.— <i>Importance of the Foliar Fibrovascular System in Vegetable Anatomy</i>	985
WISSELENGH, C. VAN— <i>Wall of Suberous Cells</i> .. .. .	985
PETERSEN, O. G.— <i>Reticulations in Vessels</i> .. .. .	986
DANGEARD, P. A.— <i>Secretory Canals of Araucaria</i> .. .. .	986
TIEGHEM, P. VAN— <i>Super-endodermal Network of the Root of Leguminosæ and Ericacæ</i> .. .. .	986
"   "   & MONAL— <i>Sub-epidermal Network of the Root of Geraniacæ</i>	986
"   " <i>Supporting Network in the Cortex of the Root</i> .. .. .	986
"   " <i>Exoderm of the Root of Restiacæ</i> .. .. .	987
DOULIOT, H.— <i>Periderm of Rosacæ</i> .. .. .	987
TIEGHEM, P. VAN, & H. DOULIOT— <i>Plants which form their Rootlets without a Pocket</i> .. .. .	987
DANGEARD, P. A.— <i>Observations on Pinguicula</i> .. .. .	987
"   " <i>Anatomy of the Salsolæ</i> .. .. .	988
MOLISCH, H.— <i>Thyllæ</i> .. .. .	988

##### (4) Structure of Organs.

DUCHARTRE, P.— <i>Rooting of the Albumen of Cycas</i> .. .. .	988
TRELEASE, W.— <i>Subterranean Shoots of Oxalis</i> .. .. .	988
GOETHE, R.— <i>Torsion of Stems</i> .. .. .	989
LOTHELIER, A.— <i>Spines of certain Plants</i> .. .. .	989
FEIST, A.— <i>Protection of Buds</i> .. .. .	989

	PAGE
JOST, L.— <i>Development of the Flowers of the Mistletoe</i> .. .. .	990
JOHNSON, T.— <i>Arceuthobium</i> .. .. .	991
JUMELLE, H.— <i>Seeds with Two Integuments</i> .. .. .	992
BESSEY, C. E.— <i>Overlooked Function of many Fruits</i> .. .. .	992
OLIVER, F. W.— <i>Trapella, Oliv., a new Genus of Pedalinea</i> .. .. .	992

### β. Physiology.

#### (1) Reproduction and Germination.

FOERSTE, A. G.— <i>Cross-fertilization</i> .. .. .	993
RIDLEY, H. N.— <i>Self-fertilization and Cleistogamy in Orchids</i> .. .. .	994
MAGNUS, P.— <i>Self-pollination of Spergularia salina</i> .. .. .	994
VEITCH, H. J.— <i>Fertilization of Cattleya labiata</i> .. .. .	994

#### (2) Nutrition and Growth (including Movements of Fluids).

MENZE, O.— <i>Daily Assimilation of Carbohydrates</i> .. .. .	994
VEVAUX— <i>Action of Light on Roots grown in Water</i> .. .. .	995
VÖCHTING, H.— <i>Influence of Radiant Heat on the Development of the Flower</i> .. .. .	995

#### (3) Irritability.

SANDERSON, J. BURDON— <i>Electromotive Properties of the Leaf of Dionæa</i> .. .. .	995
DUCHARTRE, P.— <i>Case of Abolition of Geotropism</i> .. .. .	996
MOORE, S. LE M.— <i>Studies in Vegetable Biology</i> .. .. .	996

#### (4) Chemical Changes (including Respiration and Fermentation).

HANSEN, A.— <i>Function of the Colouring Matter of Chlorophyll</i> .. .. .	997
FANKHAUSER, J.— <i>Diasiase</i> .. .. .	997
SMITH, J.— <i>Substance containing Sulphur in Cruciferous Plants</i> .. .. .	997

### γ. General.

TREUB, M.— <i>Myrmecophilous Plants</i> .. .. .	998
DELPINO, F.— <i>Myrmecophilous Plants</i> .. .. .	998
SCHUMANN, K.— <i>New Myrmecophilous Plants</i> .. .. .	998
BONNIEE, G.— <i>Comparative Cultures of the same species at different altitudes</i> .. .. .	999

## B. CRYPTOGAMIA.

### Cryptogamia Vascularia.

SABLON, LECLERC DU— <i>Antherozoids of Cheilanthes hirta</i> .. .. .	999
BERGGREN, S.— <i>Apogamy in Notochlæna</i> .. .. .	999
NEWCOMBE, F. C.— <i>Dissemination of the Spores of Equisetum</i> .. .. .	1000

### Muscineæ.

PHILIBERT— <i>Peristome</i> .. .. .	1000
WALDNER, M.— <i>Development of the Sporogonium of Andreaea and Sphagnum</i> .. .. .	1000
MATTIROLO, O.— <i>Hygrosopic Movements of the Thallus of Marchantiæ</i> .. .. .	1001

### Characeæ.

NORDSTEDT, O.— <i>New Chara</i> .. .. .	1001
„ „ <i>New Nitella</i> .. .. .	1001

### Algæ.

REINSCH, P. F.— <i>New Genera of Floridææ</i> .. .. .	1002
KLEBAHN, H.— <i>Zygosporos of Conjugatæ</i> .. .. .	1002
MURRAY, G., & L. A. BOODLE— <i>Spongoeladia</i> .. .. .	1002
HANSGIRG, A.— <i>Aerophytic Species of Ulotrichaceæ</i> .. .. .	1002
ISTVÁNFFI, G.— <i>Structure of Ulotrix</i> .. .. .	1003
WILDEMANN, E. DE— <i>Bulbotrichia</i> .. .. .	1003
TONI, J. B. DE— <i>Hansgirgia, a new genus of aerial Algæ</i> .. .. .	1003
DANGEARD, P. A.— <i>Chlorogonium</i> .. .. .	1003
„ „ <i>Chlamydomonas</i> .. .. .	1004
„ „ <i>Chlamydococcus pluvialis</i> .. .. .	1004
HAUPTFLEISCH, P.— <i>Cell membrane and Gelatinous Envelope of Desmidiææ</i> .. .. .	1004

### Fungi.

MÖLLER, A.— <i>“Spermatia” of the Ascomycetes</i> .. .. .	1006
COHN— <i>Basidiomycetes</i> .. .. .	1006
COSTANTIN, J.— <i>Heterobasidial Basidiomycetes</i> .. .. .	1007
SEYNES, J. DE— <i>Polyporeæ</i> .. .. .	1007

	PAGE
PATOILLARD, N.— <i>Prototremella</i> .. .. .	1007
VUILLEMIN, P.— <i>Ascospora Beijerinckii</i> .. .. .	1007
DIETEL, P.— <i>Uredinæ</i> and their Hosts .. .. .	1007
WARD, H. MARSHALL— <i>Structure and Life-history of Puccinia Graminis</i> .. .. .	1007
CUBONI, G.— <i>Peronospora viticola</i> .. .. .	1008
“ “ <i>Peronospora of the Rose</i> .. .. .	1008
MORINI, F.— <i>Ascophorous form of Penicillium candidum</i> .. .. .	1008
EICHELEBAUM, F.— <i>New Aspergillus</i> .. .. .	1008
QUÉLET, L.— <i>Ombrophila and Guepinia</i> .. .. .	1008
KLEBAHN, H.— <i>Peridermium Pini</i> .. .. .	1009
BOUDIER, E.— <i>Pilacre</i> .. .. .	1009
WASSERZUG, E.— <i>Fusoma</i> .. .. .	1009
COSTANTIN, J.— <i>Diptocladium</i> .. .. .	1009
MÜLLER, H.—“ <i>Eidelfäule</i> ” of Grapes .. .. .	1009
COSTANTIN, J., & ROLLAND— <i>Stysanus and Homodendron</i> .. .. .	1010
EIDAM, E.— <i>New Mould</i> .. .. .	1010
THAXTER, R.— <i>Entomophthoræ of the United States</i> .. .. .	1010
KIENITZ-GERLOFF, F.— <i>Gonidia of Gymnosporangium</i> .. .. .	1010
HARTOG, M.— <i>Recent Researches on the Saprolegniæ</i> .. .. .	1010
PERRONCITO, E.— <i>Chytridium elegans, n. sp., a Parasite of the Rotatoria</i> .. .. .	1011
TOMASCHEK, A.— <i>New Chytridium</i> .. .. .	1011
COSTANTIN, J.— <i>Parasites of the Higher Fungi</i> .. .. .	1011

### Protophyta.

GOMONT, M.— <i>Cellular Envelope of the Filamentous Nostocææ</i> .. .. .	1012
BORZI, A.— <i>Chlorothecium</i> .. .. .	1012
DANGEARD, P. A.— <i>Reproduction of Nephrocytium</i> .. .. .	1013
HANSGIRG, A.— <i>Trochiscia and Tetraedron</i> .. .. .	1013
REINSCH, P. F.— <i>Polyedriacææ</i> .. .. .	1013
MIQUEL, P.— <i>Bacillus living at a temperature exceeding 70° C.</i> .. .. .	1013
FISCHER— <i>Bacterial Growth at 0° C.</i> .. .. .	1014
HANSGIRG, A.— <i>Cellar Bacteria</i> .. .. .	1014
KOCH, A.— <i>Endosporous Bacteria</i> .. .. .	1014
BUCHNER, H.— <i>Supposed Spores of the Typhoid Bacillus</i> .. .. .	1016
NEISSER— <i>Spore-formation in the Bacilli of Xerosis conjunctivæ, Streptococci, and Cholera spirilla</i> .. .. .	1016
GALTIER, V.— <i>Pathogenic chromo-aromatic Microbe</i> .. .. .	1017
WIEBEL, E.— <i>Vibrios</i> .. .. .	1017
OLIVIER, L.— <i>Physiological Experiments on Organisms of Glairine and Baregine</i> .. .. .	1019

## MICROSCOPY.

### a. Instruments, Accessories, &c.

#### (1) Stands.

ABRENS' <i>New Erecting Microscope</i> (Fig. 161) .. .. .	1020
KLEIN'S <i>Excursion Microscope</i> (Figs. 162-164) .. .. .	1020
PRITCHARD'S <i>Microscope with "Continental" Fine-adjustment</i> (Figs. 165 and 166) .. .. .	1022
GRIFFITH'S (E. H.) <i>Fine-adjustment</i> (Figs. 167 and 168) .. .. .	1022
MAYALL, J.— <i>Necessity for a Sub-stage</i> .. .. .	1024

#### (2) Eye-pieces and Objectives.

DEFECTIVE <i>Objectives and the Binocular Microscope</i> .. .. .	1025
--	------

#### (3) Illuminating and other Apparatus.

KOCH'S & MAX WOLZ'S <i>Reflector</i> (Figs. 169-172) .. .. .	1025
NUTTALL'S (G.) <i>Warm Chamber</i> (Fig. 173) .. .. .	1027
SCHÖNLAND, S.— <i>Modification of Pagan's "Growing Slide"</i> (Fig. 174) .. .. .	1027

#### (4) Photomicrography.

JESERICH'S (P.) <i>Photomicrographic Apparatus</i> (Fig. 175) .. .. .	1029
GRIFFITH'S (E. H.) <i>Photomicrographic Camera</i> (Fig. 176) .. .. .	1031
JESERICH'S (P.) <i>Focusing Arrangement</i> (Figs. 177 and 178) .. .. .	1031
STENGLIN'S (M.) <i>Coarse and Fine Focusing Arrangements</i> (Figs. 179 and 180) .. .. .	1032
NEUHAUSS, R.— <i>Adaptation of the ordinary Eye-piece for Photomicrography</i> .. .. .	1032
STENGLIN, M.— <i>Illumination of Objects in Photomicrography</i> .. .. .	1033
SCHMIDT & HAENSCH— <i>Zirconium Light for Photomicrography</i> .. .. .	1033

#### (5) Microscopical Optics and Manipulation.

MICROSCOPICAL <i>Optics and the Quekett Club Journal</i> .. .. .	1034
--	------

#### (6) Miscellaneous.

## B. Technique.

	PAGE
(1) Collecting Objects, including Culture Processes.	
RICHTER—Agar-agar for Cultivation .. .. .	1036
POZZO, D. DAL—Albumen of Plovers' Eggs as Nutrient Medium for Micro-organisms ..	1037
BUCHNER, H.—New Method for Cultivating Anaerobic Micro-organisms (Fig. 181) ..	1037
RASKIN, M.—Milk as a Medium .. .. .	1038
PAWLOWSKY, A. D.—Cultivation of <i>Bacillus Tuberculosis</i> on Potato .. .. .	1038
ROUX, E.—Cultivation of Anaerobic Microbes .. .. .	1038
BIRCH-HIRSCHFELD—Cultivation of the "Typhus" <i>Bacillus</i> in coloured nutrient media .. .. .	1039
NOEGGERATH—New Method of cultivating Bacteria in Coloured Media for Diagnostic Purposes .. .. .	1039
PLAUT, H.—Improvements in Plaut's Flasks for sterilizing water .. .. .	1040
BARTOSCHWITSCH, S.—Fire-proof Cotton-wool Plug for Test-tubes .. .. .	1040
(2) Preparing Objects.	
MOSSO, A.—Methods of Examining Blood-corpuscles .. .. .	1040
LEIGH, R.—Preserving Blood-corpuscles for Microscopical Examination .. .. .	1041
OBERSTEIN, H.—Methods for Investigating the Structure of the Central Nervous Organs in health and disease .. .. .	1041
PETRONE, L.—Methods for Examining the Structure of the Cerebrospinal Nerves ..	1042
WEIL, L. A.—Making Preparations of Bone and Teeth and Retaining their soft parts .. .. .	1042
WOODHEAD, G. S.—Preparing large Sections of Lung .. .. .	1043
KÜENTHAL—Cleansing the Intestine of many animals of sand .. .. .	1044
ROULE, L.—Killing contractile Animals in a state of extension .. .. .	1044
FEWKES, J. W.—Preparation of Embryos of <i>Asterias</i> .. .. .	1045
FIEDLER, K.—Investigation of Generative Products of <i>Spongilla</i> .. .. .	1045
HABERLANDT, G.—New Method for Marking Root-hairs and for Hardening and Staining Plant-cells .. .. .	1045
KLEIN, L.—Preparation of Fresh-water Algae .. .. .	1046
NIKIFOROW, M.—Simple Method for Fixing Cover-glass Preparations .. .. .	1047
(3) Cutting, including Imbedding.	
CATHCART Improved Microtome (Figs. 182 and 183) .. .. .	1047
REEVES, J. E.—Thin Sections .. .. .	1048
(4) Staining and Injecting.	
MOSSO, A.—Methyl-green for observing the Chemical Reaction and Death of Cells ..	1049
NIKIFOROW, M.—Nuclear Carmine Stain .. .. .	1050
RESEGOTTI, L.—Staining Karyokinetic Figures .. .. .	1050
NIKIFOROW, M.—Safranin as a Stain for the Central Nervous System .. .. .	1051
HAMILTON, D. J.—Combining Weigert's Hæmatoxylin-copper Stain for Nerve-fibre with the use of the freezing Microtome .. .. .	1051
FERRIA, L.—Staining of Elastic Fibres with Chromic Acid and Safranin .. .. .	1053
HEINRICHER, E.—Congo-red as a Reagent for Cellulose .. .. .	1053
LOOMIS, H. P.—Simple and rapid Staining of the Tubercle <i>Bacillus</i> .. .. .	1053
NIKIFOROW, N.—Staining the Spirochæte of Relapsing Fever .. .. .	1054
SOUZA, A. DE—Pyridin in Histological Technique .. .. .	1054
GARBINI, A.—Modification of Garbini's Double Stain with Anilin-blue and Safranin ..	1054
WURSTER, C.—Congo-red as a Reagent for Free Acid .. .. .	1055
MARTINOTTI, G.—Absorption of Anilin Pigments by Living Animal Cells .. .. .	1055
GRIESBACH, H.—Theory of Microscopical Staining .. .. .	1056
GAGE, S. H.—Starch Injection-mass .. .. .	1056
(5) Mounting, including Slides, Preservative Fluids, &c.	
GARBINI, A.—Mounting of specimens to be examined with homogeneous-immersion Lenses .. .. .	1057
MARSSON, TH.—Preparing Styraç Balsam .. .. .	1057
(6) Miscellaneous.	
GARBINI'S (A.) Closed Water-bath (Fig. 184) .. .. .	1058
VRIES, H. DE—New Application of the Plasmolytic Method .. .. .	1059
PETRI, R. J.—New Method for Demonstrating and Counting Bacteria and Fungi Spores in the air .. .. .	1059
SCHNEIDEMÜHL, ELLENBERGER & BAUM—Investigating the Effect of Remedies by the Microscope .. .. .	1060
'ANNALES de Micrographie' .. .. .	1060
PROCEEDINGS OF THE SOCIETY .. .. .	1061

I.—APERTURE TABLE.

Numerical Aperture. ( $n \sin u = \alpha$ )	Corresponding Angle ( $2u$ ) for			Limit of Resolving Power, in Lines to an Inch.			Illuminating Power. ( $\alpha^2$ )	Penetrating Power. ( $\frac{1}{\alpha}$ )
	Air ( $n = 1.00$ ).	Water ( $n = 1.33$ ).	Homogeneous Immersion ( $n = 1.52$ ).	White Light. ( $\lambda = 0.5269 \mu$ , Line E.)	Monochromatic (Blue) Light. ( $\lambda = 0.4861 \mu$ , Line F.)	Photography. ( $\lambda = 0.4000 \mu$ , near Line H.)		
1.52	..	..	180° 0'	146,543	158,845	193,037	2.310	.658
1.51	..	..	166° 51'	145,579	157,800	191,767	2.280	.662
1.50	..	..	161° 23'	144,615	156,755	190,497	2.250	.667
1.49	..	..	157° 12'	143,651	155,710	189,227	2.220	.671
1.48	..	..	153° 39'	142,687	154,665	187,957	2.190	.676
1.47	..	..	150° 32'	141,723	153,620	186,687	2.161	.680
1.46	..	..	147° 42'	140,759	152,575	185,417	2.132	.685
1.45	..	..	145° 6'	139,795	151,530	184,147	2.103	.690
1.44	..	..	142° 39'	138,830	150,485	182,877	2.074	.694
1.43	..	..	140° 22'	137,866	149,440	181,607	2.045	.699
1.42	..	..	138° 12'	136,902	148,395	180,337	2.016	.704
1.41	..	..	136° 8'	135,938	147,350	179,067	1.988	.709
1.40	..	..	134° 10'	134,974	146,305	177,797	1.960	.714
1.39	..	..	132° 16'	134,010	145,260	176,527	1.932	.719
1.38	..	..	130° 26'	133,046	144,215	175,257	1.904	.725
1.37	..	..	128° 40'	132,082	143,170	173,987	1.877	.739
1.36	..	..	126° 58'	131,118	142,125	172,717	1.850	.735
1.35	..	..	125° 18'	130,154	141,080	171,447	1.823	.746
1.34	..	..	123° 40'	129,189	140,035	170,177	1.796	.741
1.33	..	180° 0'	122° 6'	128,225	138,989	168,907	1.769	.752
1.32	..	165° 56'	120° 33'	127,261	137,944	167,637	1.742	.758
1.31	..	160° 6'	119° 3'	126,297	136,899	166,367	1.716	.763
1.30	..	155° 38'	117° 35'	125,333	135,854	165,097	1.690	.769
1.29	..	151° 50'	116° 8'	124,369	134,809	163,827	1.664	.775
1.28	..	148° 42'	114° 44'	123,405	133,764	162,557	1.638	.781
1.27	..	145° 27'	113° 21'	122,441	132,719	161,287	1.613	.787
1.26	..	142° 39'	111° 59'	121,477	131,674	160,017	1.588	.794
1.25	..	140° 3'	110° 39'	120,513	130,629	158,747	1.563	.800
1.24	..	137° 36'	109° 20'	119,548	129,584	157,477	1.538	.806
1.23	..	135° 17'	108° 2'	118,584	128,539	156,207	1.513	.813
1.22	..	133° 4'	106° 45'	117,620	127,494	154,937	1.488	.820
1.21	..	130° 57'	105° 30'	116,656	126,449	153,667	1.464	.826
1.20	..	128° 55'	104° 15'	115,692	125,404	152,397	1.440	.833
1.19	..	126° 58'	103° 2'	114,728	124,359	151,128	1.416	.840
1.18	..	125° 3'	101° 50'	113,764	123,314	149,857	1.392	.847
1.17	..	123° 13'	100° 38'	112,799	122,269	148,588	1.369	.855
1.16	..	121° 26'	99° 29'	111,835	121,224	147,317	1.346	.862
1.15	..	119° 41'	98° 20'	110,872	120,179	146,048	1.323	.870
1.14	..	118° 0'	97° 11'	109,907	119,134	144,777	1.300	.877
1.13	..	116° 20'	96° 2'	108,943	118,089	143,508	1.277	.885
1.12	..	114° 44'	94° 55'	107,979	117,044	142,237	1.254	.893
1.11	..	113° 9'	93° 47'	107,015	115,999	140,968	1.232	.901
1.10	..	111° 36'	92° 43'	106,051	114,954	139,698	1.210	.909
1.09	..	110° 5'	91° 38'	105,087	113,909	138,428	1.188	.917
1.08	..	108° 36'	90° 34'	104,123	112,864	137,158	1.166	.926
1.07	..	107° 8'	89° 30'	103,159	111,819	135,888	1.145	.935
1.06	..	105° 42'	88° 27'	102,195	110,774	134,618	1.124	.943
1.05	..	104° 16'	87° 24'	101,231	109,729	133,348	1.103	.952
1.04	..	102° 53'	86° 21'	100,266	108,684	132,078	1.082	.962
1.03	..	101° 30'	85° 19'	99,302	107,639	130,808	1.061	.971
1.02	..	100° 10'	84° 18'	98,338	106,593	129,538	1.040	.980
1.01	..	98° 50'	83° 17'	97,374	105,548	128,268	1.020	.990
1.00	180° 0'	97° 31'	82° 17'	96,410	104,503	126,998	1.000	1.000
0.99	163° 48'	96° 12'	81° 17'	95,446	103,458	125,728	.980	1.010
0.98	157° 2'	94° 56'	80° 17'	94,482	102,413	124,458	.960	1.020
0.97	151° 52'	93° 40'	79° 18'	93,518	101,368	123,188	.941	1.031
0.96	147° 29'	92° 24'	78° 20'	92,554	100,323	121,918	.922	1.042
0.95	143° 36'	91° 10'	77° 22'	91,590	99,278	120,648	.903	1.053
0.94	140° 6'	89° 56'	76° 24'	90,625	98,233	119,378	.884	1.064
0.93	136° 52'	88° 44'	75° 27'	89,661	97,188	118,108	.865	1.075
0.92	133° 51'	87° 32'	74° 30'	88,697	96,143	116,838	.846	1.087
0.91	131° 0'	86° 20'	73° 33'	87,733	95,098	115,568	.828	1.099
0.90	128° 19'	85° 10'	72° 36'	86,769	94,053	114,298	.810	1.111
0.89	125° 45'	84° 0'	71° 40'	85,805	93,008	113,028	.792	1.124
0.88	123° 17'	82° 51'	70° 44'	84,841	91,963	111,758	.774	1.136

APERTURE TABLE—continued.

Numerical Aperture. ( $n \sin u = a.$ )	Corresponding Angle (2 u) for			Limit of Resolving Power, in Lines to an Inch.			Illuminating Power. ( $a^2$ .)	Penetrating Power. ( $\frac{1}{a}$ )
	Air ( $n = 1.00$ .)	Water ( $n = 1.33$ .)	Homogeneous Immersion ( $n = 1.52$ .)	White Light. ( $\lambda = 0.5269 \mu$ , Line E.)	Monochromatic (Blue) Light. ( $\lambda = 0.4861 \mu$ , Line F.)	Photography. ( $\lambda = 0.4000 \mu$ , near Line h.)		
0.87	120° 55'	81° 42'	69° 49'	83,877	90,918	110,488	.757	1.149
0.86	118° 38'	80° 34'	68° 54'	82,913	89,873	109,218	.740	1.163
0.85	116° 25'	79° 37'	68° 0'	81,949	88,828	107,948	.723	1.176
0.84	114° 17'	78° 20'	67° 6'	80,984	87,783	106,678	.706	1.190
0.83	112° 12'	77° 14'	66° 12'	80,020	86,738	105,408	.689	1.205
0.82	110° 10'	76° 8'	65° 18'	79,056	85,693	104,138	.672	1.220
0.81	108° 10'	75° 3'	64° 24'	78,092	84,648	102,868	.656	1.235
0.80	106° 16'	73° 58'	63° 31'	77,128	83,603	101,598	.640	1.250
0.79	104° 22'	72° 53'	62° 38'	76,164	82,558	100,328	.624	1.266
0.78	102° 31'	71° 49'	61° 45'	75,200	81,513	99,058	.608	1.282
0.77	100° 42'	70° 45'	60° 52'	74,236	80,468	97,788	.593	1.299
0.76	98° 56'	69° 42'	60° 0'	73,272	79,423	96,518	.578	1.316
0.75	97° 11'	68° 40'	59° 8'	72,308	78,378	95,248	.563	1.333
0.74	95° 28'	67° 37'	58° 16'	71,343	77,333	93,979	.548	1.351
0.73	93° 46'	66° 34'	57° 24'	70,379	76,288	92,709	.533	1.370
0.72	92° 6'	65° 32'	56° 32'	69,415	75,242	91,439	.518	1.389
0.71	90° 28'	64° 32'	55° 41'	68,451	74,197	90,169	.504	1.408
0.70	88° 51'	63° 31'	54° 50'	67,487	73,152	88,899	.490	1.429
0.69	87° 16'	62° 30'	53° 59'	66,523	72,107	87,629	.476	1.449
0.68	85° 41'	61° 30'	53° 9'	65,559	71,062	86,359	.462	1.471
0.67	84° 8'	60° 30'	52° 18'	64,595	70,017	85,089	.449	1.493
0.66	82° 36'	59° 30'	51° 28'	63,631	68,972	83,819	.436	1.515
0.65	81° 6'	58° 30'	50° 38'	62,667	67,927	82,549	.423	1.538
0.64	79° 36'	57° 31'	49° 48'	61,702	66,882	81,279	.410	1.562
0.63	78° 6'	56° 32'	48° 58'	60,738	65,837	80,009	.397	1.587
0.62	76° 38'	55° 34'	48° 9'	59,774	64,792	78,739	.384	1.613
0.61	75° 10'	54° 36'	47° 19'	58,810	63,747	77,469	.372	1.639
0.60	73° 44'	53° 38'	46° 30'	57,846	62,702	76,199	.360	1.667
0.59	72° 18'	52° 40'	45° 40'	56,881	61,657	74,929	.348	1.695
0.58	70° 54'	51° 42'	44° 51'	55,918	60,612	73,659	.336	1.724
0.57	69° 30'	50° 45'	44° 2'	54,954	59,567	72,389	.325	1.754
0.56	68° 6'	49° 48'	43° 14'	53,990	58,522	71,119	.314	1.786
0.55	66° 44'	49° 51'	42° 25'	53,026	57,477	69,849	.303	1.818
0.54	65° 22'	47° 54'	41° 37'	52,061	56,432	68,579	.292	1.852
0.53	64° 0'	46° 58'	40° 48'	51,097	55,387	67,309	.281	1.887
0.52	62° 40'	46° 2'	40° 0'	50,133	54,342	66,039	.270	1.923
0.51	61° 20'	45° 6'	39° 12'	49,169	53,297	64,769	.260	1.961
0.50	60° 0'	44° 10'	38° 24'	48,205	52,252	63,499	.250	2.000
0.48	57° 22'	42° 18'	36° 49'	46,277	50,162	60,959	.230	2.083
0.46	54° 47'	40° 28'	35° 15'	44,349	48,072	58,419	.212	2.174
0.45	53° 30'	39° 33'	34° 27'	43,385	47,026	57,149	.203	2.222
0.44	52° 13'	38° 38'	33° 40'	42,420	45,981	55,879	.194	2.273
0.42	49° 40'	36° 49'	32° 5'	40,492	43,891	53,339	.176	2.381
0.40	47° 9'	35° 0'	30° 31'	38,564	41,801	50,799	.160	2.500
0.38	44° 40'	33° 12'	28° 57'	36,636	39,711	48,259	.144	2.632
0.36	42° 12'	31° 24'	27° 24'	34,708	37,621	45,719	.130	2.778
0.35	40° 58'	30° 30'	26° 38'	33,744	36,576	44,449	.123	2.857
0.34	39° 44'	29° 37'	25° 51'	32,779	35,531	43,179	.116	2.941
0.32	37° 20'	27° 51'	24° 18'	30,851	33,441	40,639	.102	3.125
0.30	34° 56'	26° 4'	22° 46'	28,923	31,351	38,099	.090	3.333
0.28	32° 32'	24° 18'	21° 14'	26,995	29,261	35,559	.078	3.571
0.26	30° 10'	22° 33'	19° 42'	25,067	27,171	33,019	.068	3.846
0.25	28° 58'	21° 40'	18° 56'	24,103	26,126	31,749	.063	4.000
0.24	27° 46'	20° 48'	18° 10'	23,138	25,081	30,479	.058	4.167
0.22	25° 26'	19° 2'	16° 38'	21,210	22,991	27,940	.048	4.545
0.20	23° 4'	17° 18'	15° 7'	19,282	20,901	25,400	.040	5.000
0.18	20° 44'	15° 34'	13° 36'	17,354	18,811	22,860	.032	5.555
0.16	18° 24'	13° 50'	12° 5'	15,426	16,721	20,320	.026	6.250
0.15	17° 14'	12° 58'	11° 19'	14,462	15,676	19,050	.023	6.667
0.14	16° 5'	12° 6'	10° 34'	13,498	14,630	17,780	.020	7.143
0.12	13° 47'	10° 22'	9° 4'	11,570	12,540	15,240	.014	8.333
0.10	11° 29'	8° 38'	7° 34'	9,641	10,450	12,700	.010	10.000
0.08	9° 11'	6° 54'	6° 3'	7,713	8,360	10,160	.006	12.500
0.06	6° 53'	5° 10'	4° 32'	5,785	6,270	7,620	.004	16.667
0.05	5° 44'	4° 18'	3° 46'	4,821	5,225	6,350	.003	20.000

**GREATLY REDUCED PRICES**  
OF  
**OBJECT-GLASSES MANUFACTURED BY**  
**R. & J. BECK,**  
68, CORNHILL, LONDON, E.C.

**PRICES OF BEST ACHROMATIC OBJECT-GLASSES.**

No.	Focal length.	Angle of aperture, about	Price.	Linear magnifying-power, with 10-inch body-tube and eye-pieces.				
				No. 1.	No. 2.	No. 3.	No. 4.	No. 5.
		°	£ s. d.					
100	4 inches .. ..	9	1 10 0	10	16	30	40	50
101	3 inches .. ..	7	1 10 0	15	24	45	60	75
102	3 inches .. ..	12	2 10 0					
103	2 inches .. ..	10	1 10 0	22	36	67	90	112
104	2 inches .. ..	17	2 10 0					
105	1½ inch .. ..	23	2 10 0	30	48	90	120	150
106	1 inch .. ..	25	2 0 0					
107	1 inch .. ..	32	2 10 0	70	112	210	280	350
108	1 inch .. ..	45	2 10 0					
109	¾ inch .. ..	65	4 0 0	100	160	300	400	500
110	⅔ inch .. ..	95	5 0 0	125	200	375	500	625
111	⅕ inch .. ..	75	3 10 0	150	240	450	600	750
112	⅓ inch .. ..	120	4 10 0	200	320	600	800	1000
113	¼ inch .. ..	130	5 0 0	250	400	750	1000	1250
114	⅓ imm. .. ..	180	5 5 0	400	640	1200	1600	2000
115	⅓ imm. .. ..	180	8 0 0	500	800	1500	2000	2500
116	⅓ imm. .. ..	180	8 0 0	750	1200	2250	3000	3750
117	⅓ inch .. ..	160	10 0 0	1000	1600	3000	4000	5000
			20 0 0	2000	3200	6000	8000	10,000

**ECONOMIC ACHROMATIC OBJECT-GLASSES,**

APPLICABLE TO ALL INSTRUMENTS MADE WITH THE UNIVERSAL SCREW.

No.	Focal length.	Angle of aperture, about	Price.	MAGNIFYING-POWER, with 6-inch body and eye-pieces.		
				No. 1.	No. 2.	No. 3.
		°	£ s. d.			
150	3 inches .. ..	6	1 0 0	12	15	27
151	2 inches .. ..	8	1 0 0	18	23	41
152	1 inch .. ..	18	1 5 0	46	61	106
153	¾ inch .. ..	38	1 5 0	90	116	205
154	⅔ inch .. ..	80	1 5 0	170	220	415
155	⅓ inch .. ..	110	2 5 0	250	330	630
156	¼ inch .. ..	110	3 10 0	350	450	800
157	⅓ imm. .. ..	180	6 0 0	654	844	1500

Revised Catalogue sent on application to

**R. & J. BECK, 68, Cornhill.**



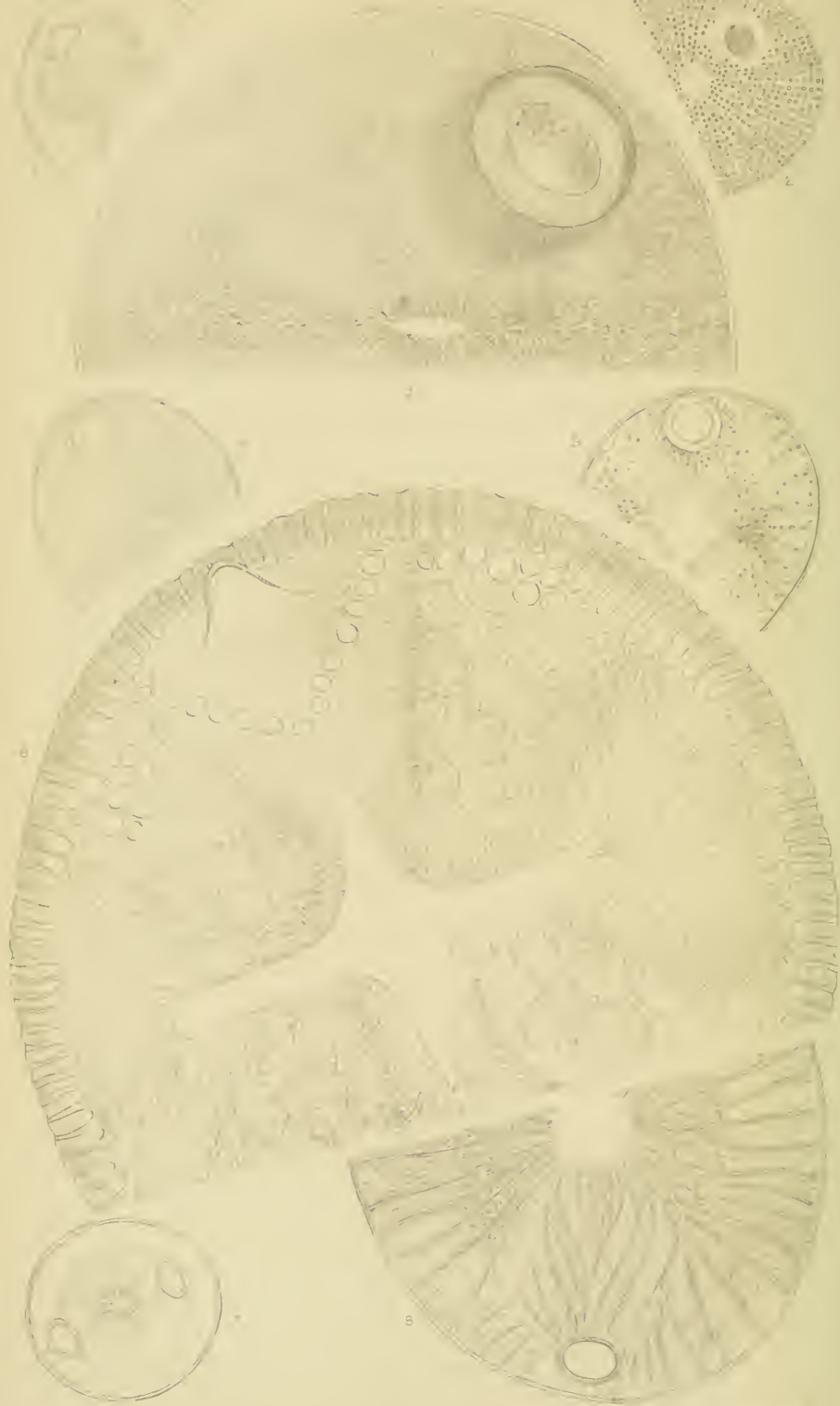



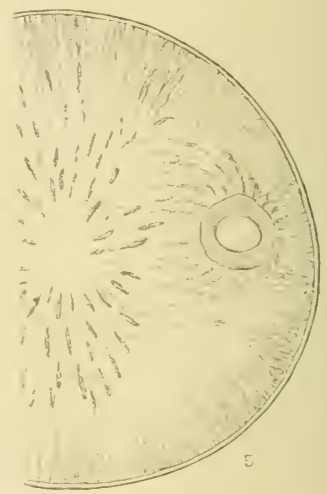
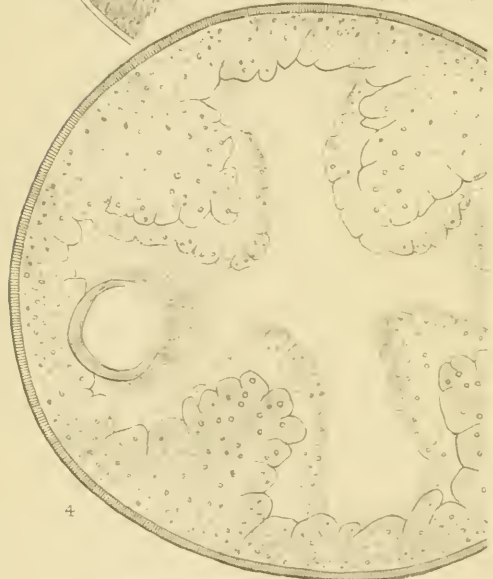
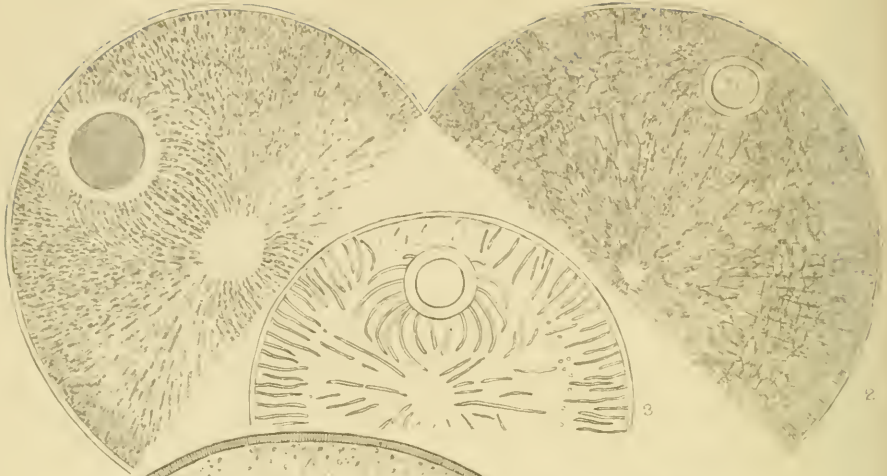



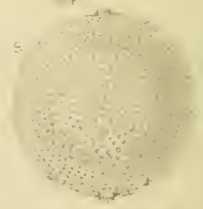
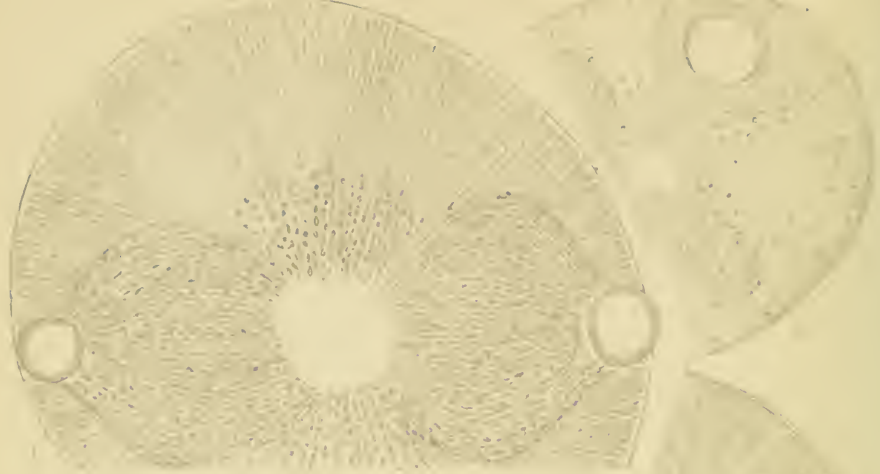

JOURNAL  
OF THE  
ROYAL MICROSCOPICAL SOCIETY.

DECEMBER 1888.

---

---

TRANSACTIONS OF THE SOCIETY.

XI.—*A Revision of the Genus Auliscus Ehrb. and of some allied Genera.*

By JOHN RATTRAY, M.A., B.Sc., F.R.S.E.

(Read 12th December, 1888.)

PLATES XII.—XVI.

IN the elaboration of the present paper, I have again had the privilege of consulting the specimens now preserved in the British Museum (Natural History) as well as many valuable preparations from the private collections of the same home and foreign observers as I have already named in my Revision of *Aulacodiscus* Ehrb.,

---

EXPLANATION OF PLATES XII.—XVI.

PLATE XII.

- Fig. 1.—*Auliscus amoenus* sp. n.  $\times$  660.  
" 2.— " *Rattrayi* Cleve MS.  $\times$  660.  
" 3.— " *raeanus* sp. n.  $\times$  660.  
" 4.— " *nitidus* sp. n. 660.  
" 5.— " *pectinatus* sp. n.  $\times$  660.  
" 6.— " *decoratus* sp. n.  $\times$  660.  
" 7.— " *sublævis* sp. n.  $\times$  660.  
" 8.— " *intermedius* sp. n.  $\times$  660.

PLATE XIII.

- " 1.—*Auliscus rugosus* sp. n.  $\times$  660.  
" 2.— " *spectabilis* sp. n.  $\times$  660.  
" 3.— " *interruptus* var. *sparsa* nov.  $\times$  660.  
" 4.— " *antiquus* sp. n.  $\times$  660.  
" 5.— " *interruptus* sp. n.  $\times$  660.  
" 6.— " *gracillimus* sp. n.  $\times$  660.

PLATE XIV.

- " 1.—*Auliscus acutiussculus* sp. n.  $\times$  660.  
" 2.— " *eximius* sp. n.  $\times$  660.  
" 3.— " *subspeciosus* sp. n.  $\times$  660.  
" 4.— " *opulentus* sp. n.  $\times$  660.  
" 5.— " *fractus* sp. n.  $\times$  660.  
" 6.— " *dissimilis* sp. n.  $\times$  660.  
" 7.—*Eupodiscus parvulus* var. *concentrica* nov.  $\times$  400.  
" 8.— " " *Grev.* MS.  $\times$  400.  
" 9.— " *decrescens* sp. n.  $\times$  600.  
" 10.—*Pseudauliscus tetraophthalmus* Cleve MS.  $\times$  660.

published by the Society in June of the present year; but in addition to the names there recorded, I would here express my gratitude to Dr. A. C. Macrae and Mr. A. de Souza Guimaraens, for the liberality and readiness with which they have placed at my disposal the resources of their cabinets, and to the former for verbal summaries which he has from time to time given me of his extensive observations on the distribution of the Diatomaceæ in the Indian Ocean and Eastern Archipelago.

**AULISCUS** Ehrb. emend.

**AULISCUS** Ehrb. emend., Mon. Ber. Ak., 1843, p. 270.

Valves circular, subcircular, or elliptical, rarely obtusely angular. Surface almost flat, or rising from central space to processes; transverse areas at right angles—rarely oblique—to line of processes frequent, flat or rising towards, and widest at the outer ends; obconical or obcordate areas between central space and processes often distinctly defined; the central portion of the valve between the processes sometimes sharply circumscribed, regularly rounded, elliptical, protuberant, or constricted opposite the central space, sometimes extending to the outer side of the processes, rarely much elevated. Colour pale to pale smoky grey, rarely dark grey or bluish. Central space circular, elliptical, obtusely angular or diamond-shaped with concave sides and protruding angles, hyaline, distinct or inconspicuous. Markings minute, punctate, in delicate continuous or pruinose striæ, sometimes forming wider, straight or curved, continuous or interrupted strands, those striæ converging to central side of processes usually distinct; rarely large, areolate, pearly, and without order; interspaces hyaline; apiculi irregularly scattered outside of central space and processes, or confined to more definite bands, sometimes few or absent; a reticulum with delicate, small or large, coarse, subequal or irregular meshes extending from central space to border or confined to central portion only, more rarely only outside of central portion, sometimes present. Processes

PLATE XV.

- Fig. 1.—*Pseudauliscus ambignus* var. *major* nov. × 660.  
 „ 2.—*Auliscus convolutus* sp. n. × 660.  
 „ 3.—*Pseudauliscus hirsutus* sp. n. × 660.  
 „ 4.— „ *anceps* sp. n. × 660.  
 „ 5.—*Auliscus cælatus* var. *delicatula* nov. × 660.  
 „ 6.— „ „ var. *mutabilis* nov. × 660.  
 „ 7.— „ „ var. *picta* nov. × 660.  
 „ 8.— „ „ var. *constricta* nov. × 660.  
 „ 9.— „ „ var. *impressa* nov. × 660.

PLATE XVI.

- „ 1.—*Auliscus decoratus* var. *affinis* nov. × 660.  
 „ 2.— „ *elegans* var. *subpunctata*, nov. × 660.  
 „ 3.— „ *cælatus* var. *tenuis* nov. × 660.  
 „ 4.—*Isodiscus mirificus* × 660.  
 „ 5.—*Auliscus intermedius* var. *simplex* nov. × 660.  
 „ 6.— „ *cælatus* var. *protuberans* var. nov. × 660.  
 „ 7.—*Pseudauliscus rotatus* sp. n. × 660.

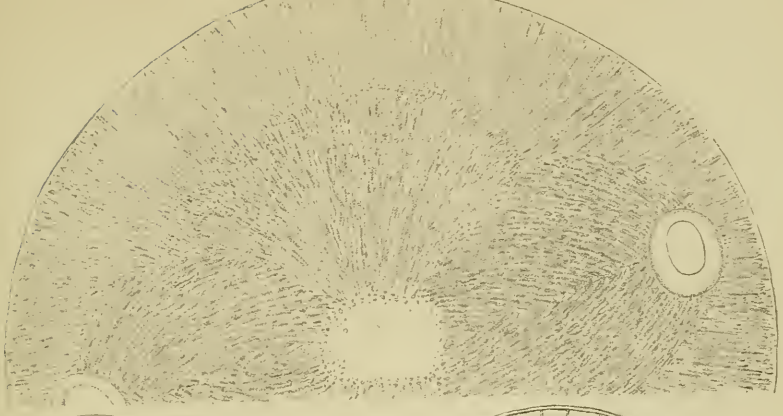

6



2

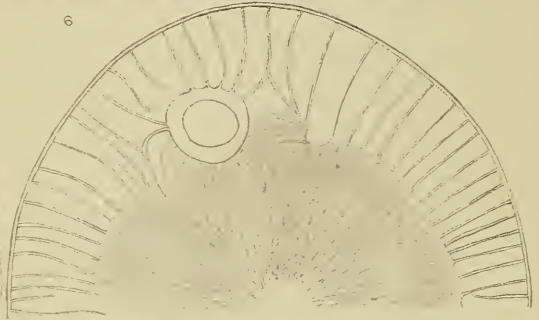

7



8

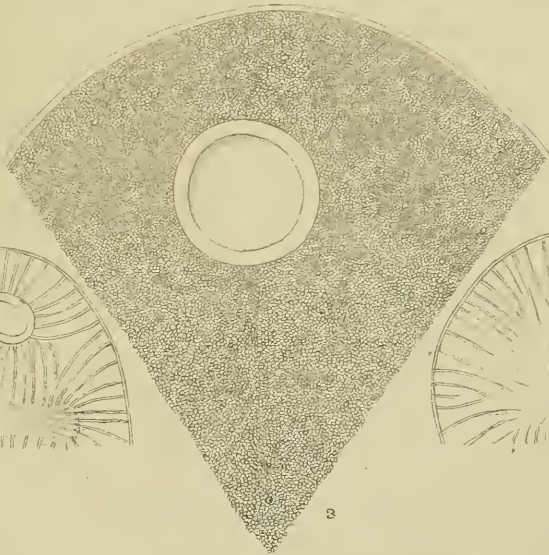

3



9

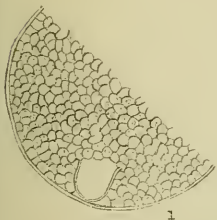

1

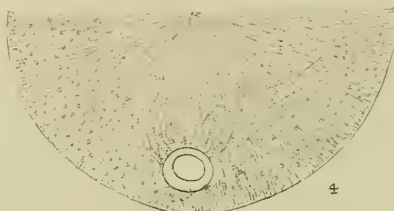

4



5

J. Rattsey del.

West, Newman & Co lith.

Auliscus &c.



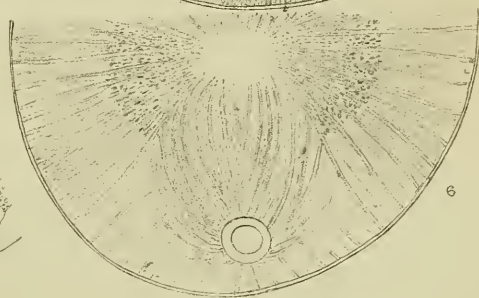
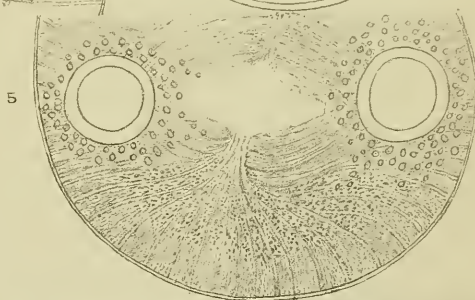
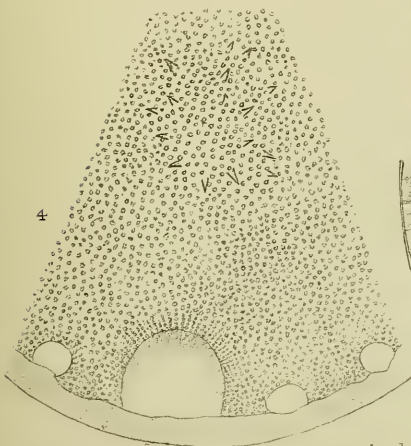
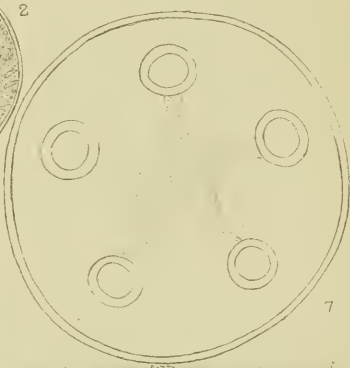
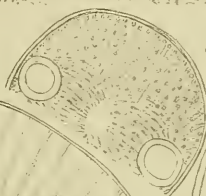
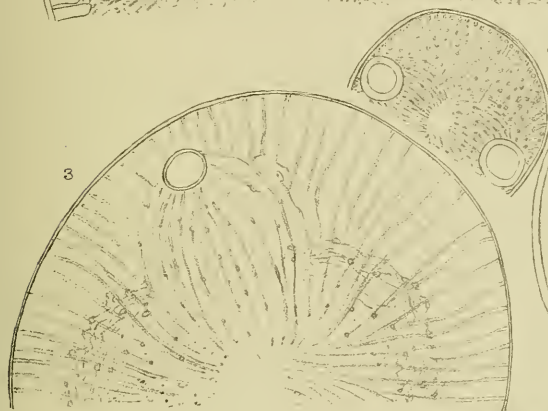



2, rarely 1, 3 or 4, mastoid and low or mammillate and more elevated, the free ends flat or convex, with central portion hyaline or punctate, round, elliptical, or obtusely angular, their border hyaline, rarely striated, the circumference smooth or with minute irregularities.—Bail. Smiths. Contrib., 1853, p. 4; *Coscinodiscus* pro parte Ehrb., ibid. 1843, p. 271, 1844, p. 77; Kütz. Sp. Alg., p. 126; *Mastodiscus* Bail. ibid., p. 4; *Eupodiscus* pro parte Smith Syn. Brit. Diat. vol. i. p. 25.

§ 1. GRANULATI.

Markings granular. No converging striæ between central space and processes.

*A. robustus.*

*A. punctatus* var. *robusta* Truan & Witt, Jerem. Diat. 1888, p. 12, pl. ii. fig. 9.

Roundly elliptical, major axis 0·1025 mm., about  $1\frac{1}{3}$  times minor. Surface with central portion indistinct, its edge convex outwards between the processes about  $\frac{3}{4}$  of radius from border, slope at border slight. Colour pale grey, darker at outer edge of central portion. Central space rounded, 0·01 mm. broad. Markings prominent round granules, subequal,  $3\frac{1}{2}$  to 4 in 0·01 mm., in inconspicuous radiating and diverging rows. Processes 2, nearer central space than border, irregularly round, about 0·02 mm. broad, their border wide, the central portion small, irregular.

Habitat: Jeremie deposit, Hayti (Weissfog!).

*A. pauper* sp. n., Sch. Atl., pl. cxxv. fig. 5 (no name).

Subcircular, diam. 0·053 mm. Surface subplain, rising but slightly at the processes, the transverse central area defined by a distinct clear band, convex outwards between, and passing on central side of, processes. Central space indefinite. Markings small, rounded granular, chiefly on an irregular space around the edge of the transverse area, and in loosely disposed radial lines outside of the clear band, interspaces hyaline. Processes 2, subcircular, 0·0125 mm. broad, their border wide, circumference subsmooth.

Habitat: Simbirsk (Thum).

*A. Rattrayi* Cleve in litt.

Roundly elliptical, major axis 0·06 mm., about  $1\frac{1}{2}$  times minor. Surface subplain. Central space circular, 0·0075 mm. broad. Markings round, granular, most evident towards the border, about 4 in 0·01 mm., interspaces narrow, hyaline. Rows distinct, radial, not converging around the processes. Processes 2, placed from  $\frac{3}{8}$  to  $\frac{1}{2}$  of distance between central space and border, their border broad, irregular.—Pl. XII. fig. 2.

Habitat: Barbadoes deposit (Cleve!).

*A. nanus*, Sch. Atl., pl. xxxii. fig. 27.

Subcircular or elliptical, diam. 0·04 mm. Surface flat. Colour hyaline, with dark border. Central space circular, hyaline, inconspicuous, about 0·003 mm. broad. Markings round, granular, minute, with wide interspaces, irregular or in faintly marked radiating lines curved towards the processes, sometimes absent between the processes and the central space, and for a distance of about 0·0025 mm. from each process. Processes 2, subcircular, 0·005 mm. broad.

Habitat: Cambridge deposit, Barbadoes (Johnson!); Simbirsk Polirschiefer (Schmidt).

*A. Clevei* Grun., Sch. Atl., pl. xxxi. figs. 1-4.

Elliptical, major axis 0·06 mm., about  $1\frac{1}{5}$  times minor. Surface rising suddenly to the processes, a narrow, clear, parallel band passing between the base of the processes on each side of the central space. Colour pale grey. Central space rounded, 0·0075 mm. broad. Markings rounded, distinct, 8 in 0·01 mm., smallest towards central space, arranged in lines radiating and diverging from the central space to the border, and concave towards the processes, absent from a narrow area at base of processes. Processes 2, about 0·0055 mm. broad at the base, free ends rounded, in girdle aspect conical, rising to about 0·0125 mm. above edge of girdle.

Habitat: Campeachy Bay (Weissflog! Cleve!).

## § 2. STRIOLATI.

No transverse median areas. Markings delicate, straight, flexuous or uniformly curved, striæ usually inconspicuous. Apiculi minute or prominent, irregularly scattered, sometimes confined to distinct areas, rarely absent.

*A. pressus* Leud.-Fort. Diat. Ceyl., p. 63, pl. vii. fig. 72.

Irregularly elliptical with obtuse extremities, major axis about 0·045 mm.,  $1\frac{1}{4}$  times minor. Surface with low processes, slope at border slight. Central space circular, about 0·003 mm. broad, distinct. Markings irregular, flexuous, but evident, short striæ radiating from the central space towards the border, those converging to the processes inconspicuous, irregular. Processes 2, subcircular, about 0·0055 mm. broad, their central portion distinctly punctate.

Habitat: Ceylon (Leuduger-Fortmorel).

*A. nitidus* sp. n.

Elliptical, major axis 0·0625 mm.,  $1\frac{1}{4}$  times minor. Surface almost flat. Colour subhyaline. Central space diamond-shaped, indistinct, minute, with straight sides, the angles in the direction of the processes, and of the minor axis. Markings obscure, punctate, isolated delicate puncta around the outer edge of the central space, a few delicate striæ

between the central space and the processes; sparsely disposed, irregular, minute, clear specks chiefly towards the border. Processes 2, close to major axis of valve, circular, 0·01 mm. broad, with wide border.—Pl. XII. fig. 4.

Habitat: Newcastle deposit, Barbadoes (Firth!).

*A. barbadosis* Grev., Trans. Mic. Soc. Lond., 1865, p. 5, pl. i. fig. 1.

Elliptical, major axis 0·05 mm., about  $1\frac{1}{4}$  times minor. Surface highest and slightly convex along the line of the processes, slope at border gentle. Colour subhyaline. Central space subcircular, distinct, about 0·003 mm. broad. Markings obscure; the two narrow, irregular, clear bands passing obliquely between the central space and the border on each side of the striæ converging to the processes, curving and branching towards their outer ends. Processes 2, placed close to the major axis, about 0·0075 mm. broad.

Habitat: Cambridge deposit, Barbadoes (Johnson!); Newcastle deposit, Barbadoes (Weissflog!).

*A. lineatus* Grove & Sturt, Journ. Quek. Mic. Cl., 1887, p. 141, pl. xii. fig. 36.

Roundly elliptical, major axis 0·065 to 0·1 mm., about  $1\frac{1}{10}$  to  $1\frac{1}{2}$  times minor. Surface rising gradually to the processes, and sloping gently to the border, three distinct ridges diverging from the angles of the central space, and dividing the area between the processes on each side into four subequal portions. Colour pale smoky grey. Central space irregular to hexagonal, from 0·0075 to 0·1 mm. broad. Markings granular, scabrous, in flexuous, somewhat curved, short striæ placed obliquely to the ridges, and converging around each process, elsewhere irregular, around the border an inconspicuous circle of more distinct granules. Processes 2, large, obovate, 0·02 to 0·025 mm. broad, their border with distinct striæ, their central portion minutely punctate.—Not *A. fenestratus* Grove & Sturt, Sch. Atl., pl. cxxv., fig. 13.

Habitat: Oamaru deposit (Grove and Sturt! R. Rattray! Doeg! Cleve!).

*A. parvulus* Grev., Trans. Mic. Soc. Lond., 1863, p. 74, pl. v. fig. 22.

Subcircular, diam. 0·0325 to 0·0375 mm. Surface flat. Colour subhyaline. Central space inconspicuous, diamond-shaped, with sides concave and angles protruding, about 0·003 mm. broad. Markings obscure, minute, punctate. Processes 3 or 4, subcircular, about 0·005 to 0·006 mm. broad, their circumference with minute irregularities.

In a valve with 3 processes these are somewhat larger, the central space is still more indistinct and triangular.

Habitat: Cambridge deposit, Barbadoes (Johnson!).

*A. Caballi* Seb. Atl., pl. xxxii. figs. 1, 2.

Circular or subcircular, diam. from 0·0425 to 0·05 mm. Surface rising gradually at the processes. Colour subhyaline. Central space rounded, indistinct, about 0·0025 mm. broad. Markings obscure, sometimes a set of delicate striæ converging to each process just visible, those at the middle of the intervening space diverging slightly towards the border; at their outer ends, and close to the border, a few well-marked round apiculi. Processes 3, circular or obtusely triangular, about 0·006 mm. broad.—H. L. Smith. Sp. Diat. Typ., No. 617.

Habitat: Venezuela (H. L. Smith!); Puerto Cabello (Grundler, Weissflog!); Santa Marta (Firth!).

*A. punctulatus* Grun., Sch. Atl., pl. xxx. fig. 10.

Circular, diam. about 0·045 mm. Surface subplain. Central space obscure. Markings obscure, striæ converging to the processes undifferentiated; apiculi distinct but minute, forming a narrow irregularly elliptical band around the clear central area, and a somewhat broader band around the border, a few close to, and on the central side of the processes. Processes 2, rounded, about 0·009 mm. broad.

Habitat: Simbirsk Polirschiefer (Schmidt).

*A. propinquus* Grove & Sturt, Journ. Quek. Mic. Cl., 1887, p. 141, pl. xii. fig. 34.

Subcircular, diam. 0·525 to 0·0625 mm. Surface flat at the centre, slope at border gentle. Colour pale grey. Central space subquadrate or rounded, 0·0035 mm. broad. Markings obscure, delicate, curved, striæ radiating and diverging from the central space towards the border; apiculi prominent, numerous, fewer on a narrow zone about  $\frac{7}{10}$  to  $\frac{3}{4}$  of radius from the centre, somewhat larger on a distinct band close to the border. Processes 2, circular, 0·01 to 0·0125 mm. broad, placed close to the central space.

Habitat: Oamaru deposit (Gray! Grove & Sturt! Hardman!).

*A. nebulo-punctatus* Leud.-Fort., Diat. Ceyl., p. 63, pl. vii. fig. 13.

Subcircular, diam. 0·0875 mm. Surface slightly elevated between the processes for about  $\frac{1}{3}$  of radius from centre, outside of this almost flat. Colour pale grey, darker around the edge of the elevated area. Central space round, 0·01 mm. broad, distinct. Markings punctate, minute, in radiating striæ straight or slightly flexuous, subpruinose on the elevated area, converging but slightly to the processes, beyond the elevated area only visible near the border; apiculi on a narrow band close to the border, distinct, crowded, irregular, minute. Processes 2, flat on the central side, elsewhere convex, reaching the border, 0·025 mm. broad, their border uniform narrow, the central portion distinctly punctate.

Habitat: Ceylon (Deby! Kitton\*).

\* In the Collection of Mr. E. Grove.

*A. normanianus* Grev., Trans. Mic. Soc. Lond., 1864, p. 82,  
pl. xi. fig. 11.

Circular or roundly elliptical, diam. 0·08 to 0·13 mm., the major axis about  $1\frac{1}{2}$  times minor. Surface rising but slightly at the processes. Colour pale smoky grey. Central space rounded, 0·0125 to 0·015 mm. broad. Markings striate, the striæ converging to the processes delicate, the others radiating and diverging towards the border, more sharply defined, rarely pruinose. Apiculi distinct on a narrow band close to the border, elsewhere irregular, sometimes a few scattered near this band at the middle of the areas between the processes and around the central space. Processes 3, rounded or obtusely triangular, 0·02 to 0·03 mm. broad, with border delicately striated.—Sch. Atl., pl. xxxii. fig. 3, pl. lxvii. fig. 5, pl. cxvii. fig. 8. Pant. Fossil. Bacil. Ung., p. 56, pl. xxx. fig. 314.

Habitat: Moron deposit (Johnson! Hardman! Kitton! Griffin!); Szakal deposit (Pantocsek!).

*A. superbus* Leud.-Fort., Diat. Ceyl., p. 63, pl. vii. fig. 70.

Subcircular, diam. 0·0475 mm. Surface with central portion having the edges distinct, angular, extending between the processes, and reaching about  $\frac{2}{3}$  of radius from centre. Central space triangular, with somewhat obtuse angles and convex sides, about 0·006 mm. broad. Markings on central portion granular, distinct, closely placed, round, subequal, the striæ converging to the processes short, and only evident close to them, those radiating from the outer edge of the central portion to the border faint, somewhat more evident near their outer ends; apiculi minute, scattered, on a narrow band at the border, but absent opposite the outer side of the processes. Processes 2, reaching the border, rounded, about 0·015 mm. broad, their central portion minutely punctate.

Habitat: Ceylon (Leuduger-Fortmorel).

*A. Stöckhardtii* Jan., Abh. Schl. Ges. väter. Cult., 1861, p. 163,  
pl. i. fig. 4.

Subcircular or roundly elliptical, major axis from 0·0875 to 0·125 mm,  $1\frac{1}{4}$  to  $1\frac{1}{5}$  times minor. Surface rising gently at the processes, elsewhere almost flat. Colour pale to dark smoky grey. Central space distinct, elliptical, with major axis at right angles to the line of the processes, irregularly round, triangular, or quadrate, from 0·01 to 0·0175 mm. broad. Markings striate, the striæ converging to the processes inconspicuous, elsewhere still more faint, radial and diverging but slightly or straight; apiculi prominent, on a distinct band extending between the processes on each side of, and inflexed opposite, the central space, and on a narrow band at the border, aggregated around the processes, sometimes absent at the outer ends of the diameter at right angles to line of processes. Processes 2,

irregularly round, 0·015 to 0·025 mm. broad, their border finely striated, and central portion minutely punctate.—Sch. Atl., pl. xxx. figs. 11–13; pl. lxvii. fig. 6. *A. racemosus* Ralfs, Trans. Mic. Soc. Lond., 1863, p. 46, pl. ii. fig. 9. *A. constellatus* Mills, Journ. Roy. Mic. Soc. Lond., 1881, p. 867, pl. xi. figs. 2, 3.

Habitat: Peruvian guano (Janisch); Cambridge deposit, Barbadoes (Johnson!); Monterey deposit (Firth!); “Barbadoes” (Greville!); Santa Maria deposit (Kinker! Rae!\*); Newcastle deposit, Barbadoes (Firth! Weissflog! Griffin!); Jackson’s Paddock Oamaru (Grove!); Oamaru deposit (Firth! Rae! Hardman! Cleve!); Santa Monica deposit (Rae! Cleve! Grove!); Szent Peter deposit (Pantocsek!); Pisagua, Peru (Weissflog!); Islay, Peru (Griffin!); W. Coast S. America (Kinker!); San Pedro and Peru (Grove!); Mejillones, Bolivia (Firth!); Ceylon (Kitton!); California, Pacific Coast (Cleve!); Iquique (Kitton!).

Var. *grandis*.—Major axis 0·225 mm.,  $1\frac{1}{4}$  times minor. Colour pale bluish grey, slightly yellowish between the processes, pale yellow around the border. Markings on the central area punctate, between this area and the punctate band in interrupted strands expanding outwards and with hyaline interspaces, towards the border in coarse, sometimes broken striæ; apiculi numerous around the processes and on the intervening bands about the semi-radius, widely scattered on the band at the border.

Habitat: Pisagua (Kitton!).

Var. *inconspicua*.—Subcircular, diam. 0·07 to 0·0925 mm. Central space sub-quadrate or rounded, 0·0075 mm. broad. Markings striate, the striæ converging to the processes distinct, wide between these, a few straight and diverging from central space, but disappearing about  $\frac{3}{5}$  of radius from centre; apiculi indistinct, on bands between processes, the band close to the border less evident, but within it a zone bearing numerous irregular apiculi.

Habitat: Oamaru deposit, New Zealand (Rae!).

Var. *subpunctata*.—Irregularly round with one large lobe, diam. about 0·105 mm. Surface with an indistinct central area slightly constricted opposite the central space. Central space circular, 0·0125 mm. broad, distinct. Markings striate, the striæ converging to the processes evident, those at border obscure; apiculi numerous, most prominent around the processes and along the edges of the central area, a single well-marked circlet around the border. Processes 2, 0·02 mm. broad.

Habitat: Oamaru deposit (Grove!).

*A. australiensis* Grev., Edin. New Phil. Journ., 1863, pl. iii. fig. 3.

Circular, diam. 0·07 mm. Surface subplain. Central space circular, distinct, 0·0075 mm. broad. Markings obscure, radiating striæ slightly curved near the sides of the processes, those between

\* In the Collections of Dr. John Murray and Dr. Griffin.

the centre and processes straight; apiculi minute, scattered. Processes 2, roundly oval, 0·0225 mm. broad.

Habitat: Sharks Bay, West Coast of Australia, in stomachs of Ascidia (Macdonald\*).

*A. formosus* Leud.-Fort., Diat. Ceyl., p. 63, pl. vii. fig. 71.

Circular or subcircular, diam. from 0·05 to 0·07 mm. Surface with low processes, elsewhere almost flat. Colour pale to pale smoky grey. Central space subcircular, distinct, from 0·005 to 0·0075 mm. broad. Markings, delicate uniform radial striæ, most evident and separated by narrow hyaline interspaces around central space, those converging to the processes indistinct; apiculi minute, irregular, distinct on a narrow band close to the border, absent on the outer side of the processes, a few smaller and more faint sometimes near the central space. Processes 2, flat on the central side, elsewhere uniformly curved, forming the arc of a circle, rarely obtusely quadrangular with slightly convex sides, from 0·015 to 0·0225 mm. broad.

Habitat: Ceylon (Macrae!† Weissflog!); 'Gazelle' expedition (Weissflog!)

*A. punctatus* Bail. Smiths. Contrib., 1853, p. 5, fig. 9.

Roundly elliptical, major axis 0·0725 to 0·125 mm., from 1/9 to 1/13 times minor. Surface sometimes with a faintly defined transverse median area, almost flat to the border. Colour pale grey. Central space rounded, distinct, sometimes somewhat elongated in the direction of the processes, from 0·0075 to 0·015 mm. broad. Markings, delicate striæ, those converging to the processes most evident, elsewhere radiating, diverging, and slightly curved, around the border sometimes hardly visible; apiculi prominent, most crowded on the transverse area and around the border. Processes 2, elliptical or circular, 0·02 to 0·0225 mm. broad.—Grev. Trans. Mic. Soc. Lond., 1863, p. 49, pl. iii. figs. 15, 16; Ralfs in Pritch. Inf., p. 845; Sch. Atl., pl. lxxvii. figs. 7, 8, pl. lxxxix. figs. 16, 17, pl. cviii. fig. 10.

Kitton believes that this species is the same as *A. pruinosus*; by Bailey it was stated to be probably a var. of the latter. Greville, I think, correctly retained both, the apiculi and other markings being very distinct.

Habitat: Cambridge deposit Barbadoes (Johnson!); Szakal deposit (Pantocsek!); Kékkö deposit (Grove!); Santa Monica deposit (Rae! Deby!); Oamaru deposit (Grove! Firth! Rae!); Yokohama mud (Kinker!); St. Bartholomew (Weissflog!); Pensacola (Kitton!); 'Gazelle' expedition (Weissflog!); Gallapagos Islands (Weissflog!); Santos (Weissflog!); Los Angelos (Hardman!); Port Elizabeth (Hardman!‡); Rembang Bay (Deby!); Apia Samoa, Vera Cruz, and Port Seguro (Deby!); Bahia (Griffin! Kitton!)

\* Formerly in the Collection of Mr. George Norman.

† In the Collection of Dr. R. K. Greville.

‡ In the Collection of Mr. A. de Souza Guimaraens.

Var. *circumducta*.

*A. pruinosus* Bail., Sch. Atl., pl. xxxi. fig. 6-9.

Major axis 0·1175 mm., about  $1\frac{1}{4}$  times minor. Surface with an indistinct but irregularly bounded transverse median area reaching almost to the border. Central space round, 0·0175 mm. broad. Markings punctate, the strands converging to the processes delicate, those on the transverse area flexuous, interrupted, diverging, near the border irregular or indistinct; apiculi minute, irregular around the border. Processes 2, rounded, 0·03 mm. broad, their centre distinctly punctate.

Habitat: North America (Weissflog!); St. Augustine, Florida (Weissflog!); Los Angeles (Hardman!); San Pedro (Grove!); Bahia (Hardman!\*); Oamaru deposit (Grove!).

Var. *abrupta*. — Major axis 0·08 mm., about  $1\frac{1}{10}$  times minor. Surface without transverse median area. Central space 0·0125 mm. broad. Markings punctate, the striæ converging to processes only visible near the latter; apiculi prominent, irregular, numerous. Processes 2, 0·02 mm. broad, close to central space.

Habitat: Santa Monica deposit (Rae!).

Var. *Carpentariæ*.

*A. pruinosus* var. *Carpentariæ* Grun., Sch. Atl., pl. xxxi. fig. 11, pl. xxxii. fig. 5.

Diam. 0·07 to 0·145 mm. Central space 0·0125 mm. broad. Markings inconspicuous, striæ closely placed, those converging to the processes short, within the border a narrow band with striæ just visible; apiculi irregular within this band, and sometimes forming a narrow zone at its outer side. Processes 2, 0·015 mm. broad, placed towards the central space.—*A. pruinosus* var. *zanzibarica* Grun., Sch. Atl., pl. xxxi. figs. 13-15; *A. macraeanus* Möll. (not Grev.) Sch. Atl., pl. xxxi. fig. 11.

Habitat: Gulf of Carpentaria (Weissflog!); Zanzibar (Weissflog! Cleve!); Manilla (Hardman!); R. Elizabeth (Hardman!†); Yokohama (Kitton!); Labuan (Cleve!).

Var. *striolata*.

*A. punctatus* Bail., Sch. Atl., pl. lxxxix. fig. 14, 15.

Circular, diam. 0·0675 mm. Surface with transverse median area undifferentiated. Central space round, 0·0125 mm. broad. Markings irregular, clear, rarely anastomosing, lines diverging from central space, the anastomoses sometimes most evident around border; apiculi few, irregular.

Habitat: Los Angeles (Hardman!); Rio de Janeiro (Rae!‡)

\* In the Collection of Mr. Julien Deby.

† In the Collection of Mr. A. de Souza Guimarães.

‡ In the Collection of Dr. Griffin.

Forma *monocula* Hardman M.S.—Subcircular, diam. 0·07 mm. Markings irregular, radiating, clear, faint lines; apiculi few, chiefly on a band near the border. Process 1, flat on central side 0·02 mm. broad.

Habitat: Los Angeles (Hardman!).

*A. accedens* sp. n., Sch. Atl., pl. cxxv. fig. 6 (without name).

Subcircular, diam. 0·08 mm. Surface rising slightly towards the processes. Colour? Central space small, rounded. Markings of delicate radiating slightly flexuous striæ, those converging to the processes well marked; apiculi numerous, distinct, absent from the area bearing converging striæ. Processes 2, circular, about 0·02 mm. broad, placed about half-way between the central space and the border, or somewhat nearer the former.

Habitat: Oamaru (Weissflog).

### § 3. INFLATI.

A prominent sharply defined central inflation extending between the processes, widest opposite the central space. No transverse median areas.

*A. inflatus* Grove & Sturt, Journ. Quek. Mic. Cl., 1887, p. 141, pl. xii. fig. 37.

Roundly elliptical, major axis 0·0875 mm., about  $1\frac{1}{8}$  times minor. Surface with the central inflation uniformly convex towards the circumference, outside of it flat to border. Colour pale smoky grey, darker along the margins of the inflation. Central space round, distinct, 0·0075 mm. broad. Markings striate, the striæ converging to the processes delicate, the others radial, straight, or slightly convex towards the processes, sometimes slightly flexuous, more evident upon than outside of the inflation, a faint reticulum near the border and around the central space; apiculi inconspicuous, chiefly around the central space, near the processes few, and confined to the inflation. Processes, 2, large, elliptical, major axis 0·025 mm., about  $1\frac{2}{3}$  times the minor, their circumference smooth.

Habitat: Oamaru deposit (Hardman! R. Rattray! Firth!).

### § 4. MIRIFICI.

Central portion between processes more elevated than peripheral, its edges distinct, constricted opposite the central space. Striæ sometimes geniculate at edges of elevated area.

*A. amœnus* sp. n.

Circular, diam. 0·045 to 0·0575 mm. Surface with central portion sharply defined, suddenly constricted opposite the central space.

Colour pale grey, darker at sides of elevated area. Central space round, indistinct, 0·005 mm. broad. Markings striate, faint, at the edges of the elevated area geniculate, beyond this area straight along a line at right angles to the direction of the processes, elsewhere slightly concave towards the processes. A hyaline irregular curved narrow band passing outwards from the centre space along the edges of the sets of converging striæ. Processes elliptical, outer side sometimes protuberant, 0·0125 mm. broad at base.—Pl. XII. fig. 1.

Habitat: Galapagos Islands (Weissflog!).

*A. elegans* Grev., Trans. Mic. Soc. Lond., 1863, p. 45, pl. ii. fig. 8.

Subcircular or roundly elliptical, diam. 0·0625 to 0·1125 mm. Surface rising from the central space around the processes, transverse median area short, extending to about 1/4 of radius from centre, with outer ends irregular, beyond this sloping gently to border. Colour, pale grey. Central space rounded, 0·0075 to 0·0125 mm. broad, indistinct. Markings striate, the striæ converging to the processes distinct, those on the transverse median areas short, straight, or slightly concave towards the processes, the narrow adjacent area hyaline, or with a faint irregular reticulum, beyond this the striæ delicate, straight, at right angles to line of processes, elsewhere concave away from this, but again slightly convex near the processes; separate, minutely punctate, narrow, irregular strands between the striæ, sometimes apiculate. Processes 2, rounded, 0·015 to 0·0225 mm. broad, with the circumference irregular and border sometimes minutely punctate.—*A. Grunovii* Sch. Atl., pl. lxxxix. fig. 7.

Habitat: Patos Island guano (Johnson!); Santa Monica deposit (Rae! Hardman!\*); Chalky Mount, Barbadoes (Griffin!); Los Angeles (Hardman!).

Var. *californica*.

*A. Grunovii* var. *californica* Grun., Sch. Atl., pl. lxxxix. fig. 8.

Roundly elliptical, major axis 0·125 mm., about  $1\frac{1}{4}$  times minor. Markings more pruinose, continuous at outer end of transverse median areas, those converging to the processes more extended, sharply curved towards their inner ends, elsewhere almost straight, around border the punctate striæ narrower than the hyaline interspaces. Processes 2, sometimes relatively smaller, elliptical, 0·015 mm. broad.

Habitat: Santa Monica deposit (Rae!).

Var. *Grunovii*.

*A. Grunovii* Sch. Atl., pl. xxx. fig. 14.

Subcircular, diam. 0·22 mm. Markings punctate, scabrous, the clear striæ-like interspaces converging around the processes uniformly curved, at outer ends of transverse area an irregular hyaline space with irregular puncta, near border an irregular crescentic clear

\* In the Collection of Mr. A. de Souza Guimaraens.

space widest on diameter at right angles to line of processes, absent opposite the processes, beyond this space the markings irregular.—Pant. Fossil. Bacil. Ung., p. 56, pl. xxix. fig. 293.

Habitat: Rio de Janeiro (Griffin! Grundler); San Pedro (Grove!); Szakal deposit (Pantocsek!); Chalky Mount, Barbadoes (Griffin!); Galapagos Islands (Cleve!).

Var. *subpunctata*.—Subcircular, diam. 0·045 mm. Central space circular, distinct, 0·005 mm. broad. Markings somewhat distant striæ, apiculi numerous, distinct, the circlet adjacent to the border obvious, the clear area opposite to the transverse area absent. Processes circular, extending from the border half-way to central area.—Pl. XVI. fig. 2.

The specimen figured by Schmidt (Atl., pl. cxxv. fig. 7) as perhaps *A. pruinus* var. must come here. It is quite distinct from *A. pruinus*.

Habitat: Oamaru deposit, New Zealand (Griffin!).

### § 5. LOCULATI.

Clear areas between central space and processes. Markings closely placed, granular or pruinose striæ, apiculi distinct.

*A. lacunosus* Grove & Sturt, Journ. Quek. Mic. Cl., 1887, p. 140, pl. xii. fig. 35.

Roundly elliptical, major axis, from 0·1 to 0·1125 mm., about  $1\frac{1}{10}$  to  $1\frac{1}{7}$  times minor. Surface with transverse median areas flat, the outer ends indistinct, rounded, about 0·0125 mm. from the circumference, between the sides and each process a distinct concavo-convex hyaline area surrounding the central sides of the latter, and from 0·0375 to 0·04 mm. in length, with rounded ends about twice as broad as its median portion. Central space distinct, rounded, hyaline, 0·015 to 0·0175 mm. broad. Markings distinct, striæ radiating and diverging from the central space, on outer portion straight along the diameter at right angles to line of processes, elsewhere slightly concave towards the processes; between their outer ends and the border a hyaline space narrowest or absent opposite the processes; apiculi at outer ends of transverse area, and forming a band close to border, but interrupted opposite the processes. Processes 2, irregularly round, about 0·025 mm. broad, with central portion minutely punctate.—Sch. Atl., pl. cxxv. fig. 4; not *A. fenestratus* Grove & Sturt, Sch. Atl., pl. cxxv. fig. 12. In Cleve's collection specimens named *A. novae-zealandicus* belong to this species.

Habitat: Oamaru deposit (Grove & Sturt! R. Rattray! Hardman! Cleve!)

*A. fenestratus* Grove & Sturt, Journ. Quek. Mic. Cl., 1887, p. 10, pl. iii. fig. 12.

Elliptical, major axis 0·08 to 0·0925 mm., from  $1\frac{1}{3}$  to  $1\frac{1}{5}$  times minor. Surface with central portion flat, slope at border gentle; a

hyaline lunate or concavo-convex area close to and on central side of each process, and close to each of these a narrower and longer straight transverse hyaline band. Colour pale grey. Central space round, inconspicuous, 0·005 to 0·0075 mm. broad. Markings delicate, granular striæ radiating from the central space, between the hyaline areas curved and converging towards the processes, on the outer portion still more delicate and slightly convex towards the processes; apiculi small, numerous, chiefly between the outer ends of the straight hyaline bands, elsewhere sparsely and irregularly placed. Processes 2, circular, about 0·01 mm. broad, with border striated.

An oblique view of one of Grove's specimens indicates the presence of delicate striæ on the girdle at right angles to its margin.

Habitat: Oamaru deposit (Grove & Sturt! Rae! Hardman! Kitton!).

#### § 6. CONVOLUTI.

Transverse median areas sharply defined, those between the central space and processes undifferentiated. Markings large areolate, unequal, somewhat pearly.

##### *A. convolutus* sp. n.

Elliptical, major axis 0·01 mm., about  $1\frac{3}{4}$  times minor. Surface rising but slightly at the processes; the transverse median areas somewhat oblique, their outer ends rounded, reaching close to the border. Central space sub-diamond-shaped, sometimes minute. Markings separated by narrow clear lines, those on the transverse areas sub-regular, with the clear intervening lines straight or curved, and but slightly oblique to the long axes of the area; a distinct band surrounding the base of each process. Processes 2, elliptical, 0·0175 mm. broad, inserted close to the border.—Pl. XV. fig. 2.

Habitat: Oamaru deposit (Grove!).

#### § 7. ORNATI.

Transverse median areas and the areas between central space and processes evident, widest towards their peripheral ends. Markings forming punctate, closely arranged striæ. Processes large, simply rounded, or sides concave, but towards their base and free ends convex.

##### *A. lunatus* Grove & Sturt in litt.

Elliptical, major axis 0·08, about  $1\frac{1}{2}$  times minor. Surface with the transverse median areas large, the edges diverging outwards, the outer angles rounded, the extremities reaching the border. At their centre a short transverse elliptical area with outer ends indistinct, an indistinct lunate band close to inner edge of processes. Colour pale smoky grey. Central space round, indistinct, 0·005 mm. broad. Markings minute punctate, striæ converging to processes and diverging from central space indistinct. Apiculi numerous, minute.

Processes 2, round, with a small protuberance on the side towards the border, 0·01 mm. broad, placed midway between the outer edge of the transverse areas and the border.

This is not *A. fenestratus* Grove & Sturt, as indicated in Sch. Atl., pl. cxxv. fig. 11.

Habitat: Oamaru deposit (Grove & Sturt!).

*A. dissimilis* sp. n.

Roundly elliptical, major axis 0·1075 mm., about  $1\frac{1}{3}$  times minor. Surface subplain; transverse areas with outer extremities rounded, reaching close to the border, and bounded by an evident clear band. Colour pale grey. Central space circular, 0·02 mm. broad. Markings delicate, subpruinose, closely-placed striæ, most evident on the transverse areas, hardly converging around the processes. Processes 6, two large, equal, and mammillate towards the ends of the major axis, two smaller subequal at the extremities of the transverse area, and two others subequal to the latter, placed towards the opposite sides of the mammillate pair, and at considerable unequal distances from them.—Pl. XIV. fig. 6.

Habitat: Yokohama (Cleve!).

*A. insignis* Cleve, Kongl. Sv. Vet. Ak. Handl. Stockh., 1881, No. 5, p. 22, pl. v. figs. 64a, 64b.

Subcircular, diam. 0·0625 to 0·12 mm. Surface with a distinct obcordate area between the centre and each process, the transverse median areas narrow, expanding towards the outer concave or substraight ends, their outer edges clear, well-marked. Colour pale grey, darker along edges of transverse and obcordate areas. Central space 0·0075 to 0·015 mm. broad. Markings obscure, punctate, sometimes between the areas darker irregular spots. Processes 2, tapering gradually to rounded apex, 0·015 mm. broad.—Sch. Atl., pl. lxxxix. fig. 1.

Habitat: Galapagos Islands (Cleve, Weissflog!).

*A. gracillimus* sp. n.

Subcircular, diam. 0·2 mm. Surface flat at centre, the obconical elevated area around processes short, extending only to outer ends of angles of central space, the transverse median areas indistinct, with outer angles obtuse and ends rounded. Colour pale grey. Central space with sides slightly concave outwards, and angles slightly protuberant, about 0·03 mm. broad. Markings obscure; apiculi absent; a reticulum with delicate meshes evident, absent from central space. Processes 2, mammillate, free ends rounded, near their base a series of subparallel striæ evident.—Pl. XIII. fig. 6.

Habitat: Santa Monica deposit (Rae! Firth!).

*A. antiquus* sp. n.

Roundly elliptical, major axis 0·125 mm.,  $1\frac{1}{3}$  times minor. Surface rising slightly to processes, outlines of elevated areas between central space and processes obconical, irregular and acutely angular, those of transverse median areas indistinct, but outer ends slightly convex and irregularly angular. Colour pale grey. Central space indistinct, sides deeply concave outwards. Markings obscure, short faint striæ visible around the processes, a few irregular costate lines at the outer ends of the transverse, and between adjacent sides of these and the obconical areas; apiculi minute, irregular between the elevations. Processes 2, uniformly convex, about 0·02 mm. broad.—Pl. XIII. fig. 4.

Habitat: Santa Monica deposit (Rae!).

*A. decoratus* sp. n.

Roundly elliptical, major axis 0·15 mm., about  $1\frac{1}{4}$  times minor. Surface with obconical elevated areas around processes well marked, their sides straight or slightly concave, extending to the border; the transverse median areas of same size as foregoing, but with outer angles somewhat more obtuse. Colour pale grey. Central space 0·0175 mm. broad, inconspicuous, sides deeply concave outwards, the angles obtuse, more protuberant on the transverse areas than towards the processes. Markings delicate punctate, in flexuous lines on the transverse and obconical areas, and in less evident straight oblique lines between their inner ends; elsewhere irregular; apiculi absent; around the outer edge an irregular band of radially elongate or rounded prominent pearly markings, sometimes double and extending farthest inwards between outer ends of transverse and obconical areas, a single less evident straight band passing from each angle of the obconical areas and meeting at a short distance within the processes on a line joining them with the centre. Processes 2, small, with free ends obtuse.—Pl. XII. fig. 6.

Habitat: Santa Monica deposit (Rae!).

Var. *affinis*. — Major axis from 0·0925 to 0·22 mm.,  $1\frac{1}{6}$  to  $1\frac{1}{2}$  times minor. Markings more distinct, scabrous, those in the prominent band at border extending less deeply inwards between the transverse and obconical areas, no bands meeting on the obconical areas within the processes. Processes larger, more protuberant, sides concave outwards, free ends rounded.—Pl. XVI. fig. 1.

This var. is intermediate between *A. decoratus* and *A. hardmanianus*.

Habitat: Santa Monica deposit (Rae!); Santa Maria deposit (Rae!).

*A. eximius* sp. n.

Roundly elliptical, major axis 0·0925 mm., about  $1\frac{1}{6}$  times minor. Surface rising slightly at processes, obconical areas around the latter

distinct, their outer angles rounded, the transverse median areas narrow, clavate. Colour hyaline, light grey around edges of these areas. Central space inconspicuous, 0·015 mm. broad. Markings indistinct punctate, in faint radiating lines diverging from centres of transverse and obconical areas, elsewhere obscure; apiculi few, irregular, chiefly between the angles of these areas. Processes 2, roundly elliptical, about 0·02 mm. broad, around their base a series of evident parallel striæ.—Pl. XIII. fig. 2.

Habitat: Santa Monica deposit (Rae!).

*A. hardmanianus* Grev., Trans. Mic. Soc., 1866, p. 6, pl. ii. fig. 17.

Roundly elliptical, major axis from 0·075 to 0·2 mm., about  $1\frac{1}{2}$  to  $1\frac{1}{4}$  times minor. Surface flat at centre. Obconical areas between central space and processes, and the transverse sometimes narrower areas rising slightly outwards, their sides sharply defined and outer ends indistinct, the remaining portions flat to border. Colour pale grey. Central space 0·0125 to 0·03 mm. broad. Markings prominent, distant striæ stretching between adjacent sides of obconical and transverse areas, the striæ around and at right angles to margins of these areas numerous, distinct, traceable across about  $\frac{1}{3}$  of the intervening portions, often curved at the outer ends, those around border more faint, straight, or slightly convex towards the processes, irregular, distinct puncta about middle of obconical areas and intervening spaces; apiculi sometimes present. Processes 2, conical free ends rounded, from 0·015 to 0·025 mm. broad.—Sch. Atl., pl. lxxvii. fig. 1, pl. lxxxix. fig. 4. *A. Joysonii* Sch. Atl., pl. lxxvii. fig. 2. *A. hardmanianus* var. (?), Sch. Atl. pl. cviii. fig. 1. *A. hardmanianus* var. *haytiana* Truan & Witt, Jerem. Diat., 1888, p. 12, pl. ii. fig. 4.

In smaller valves the outer ends of the elevated areas bearing the processes are greatly expanded and rounded.

Habitat: Santa Monica deposit (Kinker! Firth! Cleve! Hardman! Deby!); Santa Maria deposit (Rae!); Santa Barbara deposit (Griffin!); Oamaru deposit (Grove! R. Rattray!); Monterey deposit (Hardman!); Crescent City, California (Weissflog!); San Pedro (Grove); Los Angeles, California (Hardman!).

Var. *futilis*.—Elliptical, major axis 0·075 mm.,  $1\frac{1}{2}$  times minor. Surface with transverse and obconical areas indistinct, outer ends of former close to border. Central space with the angles on the transverse area extending close to the outer end of this area. Markings most evident on the transverse area, a few indistinct lines passing to the edges of the areas around the processes.

Habitat: Santa Monica deposit (Rae! Firth!)

Var. *labyrinthula*.—Subcircular, diam. 0·0725 mm. Surface, with outer ends of transverse areas, sharply defined. Markings distinct broad clear lines, convex towards the processes, radiating from the angles at outer ends of transverse areas, and similar irregularly curved lines passing between the angles of the adjacent transverse and obconical areas, and sometimes anastomosing. Processes 2, one regu-

larly rounded, the other with sides concave at the middle and with rounded protuberant ends.

Habitat: Santa Monica deposit (Rae!).

Var. *obscura*.—Roundly elliptical, major axis 0·145 mm., about  $1\frac{1}{6}$  times minor. Surface, with outer ends of transverse median areas, broad and slightly convex; the sides concave. Central space obscure. Markings obscure punctate, delicate striæ around the outer ends of the transverse areas; between the elevations a few large irregular spots.

Habitat: Santa Monica deposit (Rae!).

Var. *bifurcata*.—Major axis from 0·1 to 0·18 mm. Surface, with the four areas, sharply defined, the outer ends of those passing to processes close to border, but slightly convex. The outer ends of the transverse areas bifurcate, the branches tapering outwards and curving towards one another; the intervening central portion convex. Markings distinct, punctate at the middle of these areas and of the intervening portions. Processes rounded.

In Prof. P. T. Cleve's collection of *Aulisci*, preserved in the Royal Botanical Museum, Stockholm, this is named *Auliscus nobilis* Cleve MS.

Habitat: Oamaru deposit (Grove & Sturt! Rae!) Jackson's Paddock, Oamaru (Kitton!).

#### *A. intestinalis* Sch. Atl., pl. cviii. fig. 2.

Roundly elliptical, major axis 0·13 mm., about  $1\frac{1}{11}$  times minor. Surface with the transverse median and obconical areas sharply defined, subequal, expanding regularly and rapidly outwards from their inner ends. Markings delicate striæ radiating outwards from the centres of the transverse areas; short prominent clear lines distinct between the sides of the adjacent areas, and around the outer ends of the transverse areas, convolute and frequently anastomosing; non-apiculate. Processes 2, large, mammillate, with rounded free ends.

Habitat: Santa Monica deposit (Kinker!).

#### *A. pectinatus* sp. n.

Elliptical, major axis 0·0625 mm., about  $1\frac{1}{8}$  times minor. Surface rising but slightly to the processes, transverse median areas narrow, indistinct. Colour pale smoky grey. Central space with sides slightly concave, the angles in the direction of processes most protuberant and almost extending to inner edges of latter, about 0·01 mm. broad. Markings obscure, punctate, on the transverse areas more distinct, delicate almost parallel striæ passing obliquely from the edges of the transverse area to the processes, those diverging from the outer ends of this area to the border more evident, curved; apiculi minute, crowded around the processes, few in the course of the oblique striæ. Processes 2, round, 0·0125 mm. broad.—Pl. XII. fig. 5.

In Cleve's collection specimens of this species occur under the name *A. Sturtii* Cleve MS.

Habitat: Oamaru deposit (Grove & Sturt!).

*A. raeanus* sp. n.

Roundly elliptical, major axis 0·15 mm., about  $1\frac{1}{3}$  times minor. Surface rising gradually from centre, steeply from border to processes; transverse median areas oblique to line joining processes, flat on central portion, with outer ends indistinct, broader, rounded, and close to the border. Colour pale grey. Central space elliptical, major axis corresponding in direction with axis of transverse area, 0·0175 mm. long, about  $2\frac{1}{2}$  times minor. Markings punctate and irregular around the central space; striæ delicate, flexuous around the processes and at middle of outer portion of transverse areas, straight between outer ends of latter and the nearer process, elsewhere slightly convex towards the process near the border. Processes 2, elliptical, 0·03 mm. broad, delicate parallel closely placed striæ contiguous to the markings on their central side.—Pl. XII. fig. 3.

Habitat: Oamaru deposit (Rae!).

*A. Biddulphia* Kitton, Sch. Atl., pl. lxxvii. fig. 3.

Elliptical, major axis 0·125 mm., about  $1\frac{1}{3}$  times minor. Surface with obcordate areas between central space and processes well defined, transverse median areas less prominent, widening greatly outwards, with outer angles rounded, the ends close to the border, slightly convex. Colour pale grey. Central space with the angles but slightly protuberant, 0·0175 mm. broad. Markings minute, punctate, delicate striæ, only visible about outer edges of obcordate and transverse areas. Processes 2, large, the sides towards the base concave, the ends convex.

Habitat: Santa Monica deposit (Weissflog! Kitton! Cleve).

Var. *prominens*.

*A. Biddulphia* var., Sch. Atl., pl. lxxxix. fig. 2.

Major axis from 0·1325 to 0·16 mm., from  $1\frac{1}{5}$  to  $1\frac{1}{7}$  times minor. Surface with obcordate and transverse areas more evident, outer ends of the latter narrower and farther from border. Markings punctate, more evident, the striæ converging to the processes and diverging around outer ends of transverse area distinct, large blunt apiculi prominent between transverse and obcordate areas.

Habitat: Santa Monica deposit (Rae! Weissflog! Hardman! Firth!).

Var. *dentata*.

*A. Biddulphia* var.? Grun., Sch. Atl., pl. lxxxix. fig. 3.

Surface with obcordate and transverse areas indistinct. Markings delicate striæ converging to processes and around border, sometimes also passing obliquely inwards from edges of transverse areas; apiculi prominent at outer ends of transverse areas, elsewhere smaller and less distinct. Processes more rounded.

Habitat: Santa Monica deposit (Schmidt).

## § 8. LINEOLATI.

Transverse median areas indistinct or absent. Markings distinct, forming rough strands or narrow sharply defined pruinose striæ, entire or interrupted around central space. The interspaces distinct, usually wide, hyaline.

*A. interruptus* sp. n.

Roundly elliptical, major axis 0·1125 to 0·15 mm., about  $1\frac{1}{6}$  to  $1\frac{1}{10}$  times minor. Surface rising gradually near the processes, transverse median areas at right angles to line of processes inconspicuous, with faint rounded outer ends. Colour pale grey. Central space round, distinct, about 0·0125 mm. broad. Markings coarse striæ with irregular edges, and with hyaline wide interspaces, those converging to the processes and on the transverse median areas often interrupted, around the border more regular, but of unequal lengths. Processes 2, large, close to ends of major axis, about 0·02 mm. broad.—Pl. XIII. fig. 5; Sch. Atl., pl. cviii. fig. 8.

This species has sometimes been associated with *A. moronensis* Grev., from the type of which it differs in the character of its markings.

Habitat: Santa Monica deposit (Rae!); Kékkö deposit (Kinker); San Pedro (Grove!); Moravian Tegel (Kinker!); Yokohama mud (Kinker!).

Var. *sparsa*.—Circular, diam. 0·075 mm. Markings similar, but the striæ converging to the processes more sharply curved, only a few on the transverse median areas, those around the border more crowded and irregular, delicate apiculi on the transverse areas, chiefly aggregated about their outer ends.—Pl. XIII. fig. 3.

Habitat: Oamaru deposit (Hardman!).

*A. rugosus* sp. n.

Roundly elliptical, major axis 0·095 mm. Surface rising but slightly to the processes. Colour pale smoky grey. Central space circular, distinct, 0·0125 mm. broad. Markings pruinose, in rounded or narrow irregular patches, forming interrupted irregular curved strands between central space and processes and more straight but more inconstant strands on the transverse areas, elsewhere more crowded and without order, short strands evident on the distal side of the processes. Processes large, circular, their circumference rugose, with broad hyaline border.—Pl. XIII. fig. 1.

Habitat: Peruvian guano (Firth!).

*A. moronensis* Grev., Trans. Mic. Soc. Lond., 1864, p. 83, pl. xi. fig. 6.

Roundly elliptical, major axis 0·07 mm., about  $1\frac{1}{8}$  times minor. Surface rising slightly near the processes, elsewhere almost flat. Colour pale grey. Central space rounded, about 0·0075 mm. broad. Markings distinct granular pruinose striæ, those converging to the

processes most prominent, the others straight, radiating, and divergent, close to the border more delicate, non-pruinose, 8 to 10 in 0·01 mm.; apiculi inconspicuous, irregular. Processes 2, circular, about midway between the extremities of major and minor axes, 0·015 mm. broad, their circumference with minute irregularities.—Sch. Atl., pl. xxxii. fig. 4, pl. cviii. fig. 7. Pant. Fossil. Bacil. Ung., p. 56, pl. xix. fig. 172.

A specimen in Weissflog's collection, named *A. moronensis* var. *pruinus*, belongs to this species.

Habitat: Moron deposit (Johnson! Weissflog!); Szakal and Kékkö deposits (Pantocsek!); Szent Peter deposit (Pantocsek! Firth! Doeg!); Oamaru deposit (Grove & Sturt!); Pensacola (Grove!).

*A. Hauckii* Pant., Fossil. Bacil. Ung., p. 56, pl. xxx. fig. 304.

Circular, diam. from 0·07 to 0·0925 mm. Surface rising but slightly to the processes, transverse median areas indistinct, with outer ends rounded close to border. Colour dark bluish grey, sometimes somewhat mottled. Central space circular, 0·015 mm. broad, sometimes roundly elliptical with long axis at right angles to direction of processes. Markings minute punctate, in prominent strands, those converging to the processes closely placed with narrow hyaline interspaces, those on the transverse area irregular, radiating and diverging, widest near the central space, sometimes curved, near the border becoming delicate straight uniform striæ. Processes 2, circular, 0·0175 to 0·025 mm. broad, their circumference subregular. Sch. Atl., pl. cviii. figs. 8, 9.

Habitat: Szent Peter deposit (Pantocsek! Hardman! Grove! Kinker!); Kékkö deposit (Pantocsek! Kinker!); Szakal deposit (Pantocsek!).

*A. confluens* Grun., Sch. Atl., pl. xxxi. fig. 16; pl. xxxii. figs. 6-8.

Circular, diam. from 0·045 to 0·115 mm. Surface rising gently from the centre to the processes, elsewhere almost flat, slope at border slight. Colour pale grey. Central space round, from 0·005 to 0·01 mm. broad, sometimes eccentric. Markings distinct, the converging striæ evident all round the processes, the others straight radial, or but slightly curved and divergent, numerous shorter striæ around the border, interspaces wide, hyaline; apiculi minute, numerous, scattered at wide irregular intervals along the striæ. Border with delicate striæ, 8 to 10 in 0·01 mm., about 0·0025 mm. broad, inner edge indistinct, in small valves obscure. Processes 2, rarely 1 or 3, round, 0·005 to 0·015 mm. broad, sometimes unequal on the same valve, or unsymmetrical and confined to one of its halves, their circumference regular.

Habitat: Campeachy Bay (Weissflog! Hardman! Cleve); Zanzibar (Weissflog!); Kékkö, Szakal, Szent Peter deposits (Pantocsek!); Bahía (Kitton).

*A. pruinus* Bail. Smiths. Contrib., 1853, p. 5, pl., figs. 5-8.

Circular or subcircular, diam. 0·0675 to 0·13 mm. Surface rising slightly near the processes, slope at border gentle. Colour pale or pale smoky grey. Central space rounded, 0·005 to 0·0075 mm. broad. Markings pruinose, lines distinct, entire or interrupted, those converging to the processes most curved near their outer ends, the others radiating straight, or gently curved towards the processes, with narrow hyaline interspaces, sometimes more crowded around border; non-apiculate. Processes 2 or 3, round, 0·0125 to 0·025 mm. broad, their circumference with slight irregularities.—Ralfs in Pritch. Inf., p. 845. Grev. Trans. Mic. Soc. Lond., 1863, p. 48, pl. iii. fig. 13. H. L. Smith, Sp. Diat. Typ. Sup. No. 706.

In H. L. Smith's specimens the bevelled edge described by Bailey, but questioned by Greville, is quite distinct. The form described as perhaps *A. pruinus* var. by Schmidt (Atl., pl. cxxv. fig. 8) may come here.

Habitat: Charleston Harbour (Kitton!); Bahia (Kitton! Hardman! Deby!); Pensacola, Florida (H. L. Smith!); Nottingham, U.S., and Port Elizabeth (Hardman!\*).

*A. acutiusculus* sp. n.

Elliptical, major axis 0·14 mm., about  $1\frac{1}{2}$  times minor. Surface rising steeply from central space to processes, the intervening areas flat at centre and sloping gently at border. Colour dark grey. Central space circular, 0·02 mm. broad. Markings granular, irregular, the lines converging to the processes prominent, irregular, closely placed, those radiating from the central space on the intervening areas straight, indistinct in their inner half, more evident and crowded around the border, interspaces hyaline. Processes 2, elliptical, 0·0175 mm. broad, reaching the border.—Pl. XIV. fig. 1.

Habitat: Santa Barbara deposit (Hardman!); San Pedro (Grove!)

§ 9. STELLATI.

Surface divided into zones. Markings costate, distant, arranged in a star-shaped manner around central space on the innermost zone. Border formed by a single band of granules in contact with one another.

*A. stelliger* Petit., Fonds de la mer, 1877, p. 37, pl. v. fig. 35.

Elliptical, major axis about 0·04 mm.,  $1\frac{1}{2}$  times minor. Surface with 3 distinct areas: the central subcircular, extending to about  $\frac{1}{4}$  of radius, the median extending almost to the semi-radius, sharply defined, the external widest. Central space minute, circular. Markings on the central area, 5 distinct costate rays in the form of a star, on the median area the rays irregular, straight or slightly bent, on the

\* In the Collection of Mr. A. de Souza Guimaraens.

external area straight and radial between those passing obliquely outwards from the processes, at the inner edge of the external area a band of evident round granules with hyaline interspaces. Processes 4, symmetrical, 2 smaller at the ends of minor axis, elliptical, about 0·003 mm. broad.

Habitat: Campbell Island, N. Zealand (Petit).

### § 10. COSTATI.

Transverse median areas with outer ends rounded, rarely indistinct. Markings narrow, continuous, distinct, widely arranged costæ and delicate striæ around border, transverse areas often punctate, sometimes with a faint reticulum near their outer ends.

#### *A. incertus* Sch. Atl., pl. lxxxix. figs. 18, 19.

Elliptical, major axis about 0·05 mm., from  $1\frac{1}{3}$  to  $1\frac{1}{5}$  times minor. Surface rising slightly from central space to processes, transverse median areas indistinct or absent. Colour pale grey. Central space circular, distinct, from 0·0045 to 0·0075 mm. broad. Markings distinct striæ, those converging to the processes distant, the others diverging, straight along the minor axis, elsewhere convex towards the processes, puncta sometimes distinct between the central space and outer limits of the converging striæ. Processes 2, subcircular, from 0·0075 to 0·012 mm. broad.

Habitat: Santa Monica (Rae!); Balearic Islands (Weissflog!); Newcastle deposit, Barbadoes (Firth!); Moron deposit (Firth!).

#### *A. obscurus* sp. n.

Elliptical, major axis 0·04 mm., about  $1\frac{1}{5}$  times minor. Surface rising steeply near the processes, transverse median areas indistinct, with outer ends rounded close to border. Colour hyaline. Central space round, indistinct, 0·005 mm. broad. Markings delicate striæ converging to processes, elsewhere the striæ radial, straight or slightly curved, more distinct around the border, most crowded at the outer portion of the transverse areas. Processes 2, prominent, conical, with sides straight or slightly convex at the base, the apices rounded; the inner side obscure.

Habitat: Zanzibar (Weissflog!).

#### *A. sculptus* Ralfs in Pritch. Inf., p. 845, pl. vi. fig. 3.

Major axis 0·055 to 0·0875 mm., from  $1\frac{1}{4}$  to  $1\frac{1}{10}$  times minor. Surface rising slightly near the processes, transverse median areas distinct, with outer ends regularly rounded. Colour pale grey. Central space rounded, 0·01 to 0·0125 mm. broad, sometimes elongated in direction of processes. Markings distant, the lines converging to the processes distinct, those on transverse areas radiating, straight or slightly curved, around their ends flexuous and almost parallel to the edge, near border convex towards processes. Processes

2, rounded, about 0·0125 mm. broad, their circumference almost smooth.—Brightw. Quart. Journ. Mic. Sci., 1860, p. 94, pl. v. fig. 5. Ralls in Pritch. Inf., p. 845. Grav. Trans. Mic. Soc. Lond., 1863, p. 43, pl. ii. figs. 1–3. Sch. Atl., pl. xxxii. figs. 21, 22. Van Heurck, Syn. Diat. Belg., p. 209, pl. cxvii. figs. 1, 2. Raben. Alg. Europ., Nos. 2487, 2555, 2556, 2558. *Eupodiscus sculptus* W. Sm. Syn. Brit. Diat., i. p. 25, pl. iv. fig. 42.

In Rabenhorst's Alg. Europ., No. 2556, there is noted *Auliscus sculptus*  $\gamma$  *interruptus*. This specimen, which I have not seen, is by Schwarz made synonymous with *A. Gregorii* Janisch.

Habitat: Poole Bay (W. Smith!); Lamlash (Gregory!); Ipswich (Kitton!); sponge sand, West Indies (Dallas!); Ballast, Mediterranean (Griffin!); Mer du Nord (Van Heurck!); "In Mare" (H. L. Smith!); coast of Holland (Suringar); coast of Denmark (Heiberg); Mejillones, Peru (Kinker!); Levant, Cuxhaven, Sheerness, and Galway (Grove!); Smyrna sponges (Grove!); Auckland (Cleve!); mud from Glückstadt, Port William, Falkland Islands, Elbe above Cuxhaven (Rabenhorst and Schwarz!).

*A. rhipis* Sch. Atl., pl. xxxii. figs. 10, 11.

Elliptical, major axis from 0·045 to 0·1 mm.,  $1\frac{1}{8}$  to  $1\frac{1}{12}$  times minor. Surface with transverse median areas distinct, their outer ends rounded and well marked. Colour pale grey. Central space elliptical, rectangular, or diamond-shaped, 0·0075 to 0·01 mm. broad. Markings striate, those converging to the processes distinct, finely punctate; those on the transverse areas faint, wide, radiating, straight, or curved and diverging, the interspaces minutely and closely punctate; those around the border well defined, straight along the minor axis, elsewhere convex towards the processes, the inner ends of the interspaces rounded towards the centre at the transverse areas. Processes 2, round, 0·01 to 0·015 mm. broad.

Habitat: Japan (Grundler); Bay of Kerguelen dredged by H.M.S. 'Challenger'—19th Jan. 1874—20 to 60 fathoms (Rae!); King George's Sound (Grove!); Yokohama (Cleve!).

*A. intercedens* Jan., Sch. Atl., pl. xxxii. fig. 9.

Roundly elliptical, major axis 0·0875 mm., about  $1\frac{1}{8}$  times minor. Surface with central area distinct, its outer edge convex between the converging striæ, reaching about  $\frac{4}{5}$  of radius from the centre and passing close to the processes on their outer side. Central space subcircular, about 0·015 mm. broad. Markings striate, those converging to the processes faint, punctate, closely placed; those on the central area similar, diverging, slightly curved; outside of the central area distant, distinct, continuous, straight, along the minor axis, elsewhere slightly convex towards the processes. Processes 2, round, 0·01 mm. broad, their border narrow.

Habitat: Bay of Carpentaria (Janisch).

*A. spectabilis* sp. n.

Elliptical, major axis 0·1125 mm., about  $1\frac{1}{4}$  times minor. Surface rising slightly for about  $\frac{1}{2}$  radius from centre, highest zone circular, at inner side of processes indistinctly defined, about 0·0125 mm. broad, beyond this sloping gently to the border. Colour pale grey. Central space minute, about 0·0025 mm. broad, indistinct. Markings punctate, in straight radiating lines, those converging to the processes more evident, a faint irregular reticulum upon the highest zone, and less evident on outer portion of depressed central area, outside of this zone narrow, distinct, almost straight lines passing to the border. Processes 2, circular, 0·0125 mm. broad, their border finely striated.—Pl. XIII. fig. 2.

This species is related to *A. cælatus* through *A. cælatus* var. *picta*.  
Habitat: Yokohama (Hardman!).

*A. splendidus* sp. n. *A. gigas* Grun. (not Ehrb.), Sch. Atl.,  
pl. cxvii. figs. 5-7.

Elliptical, major axis, 0·15 to 0·305 mm.,  $1\frac{1}{4}$  to  $1\frac{1}{4}$  times minor. Surface rising but slightly near the processes, elsewhere flat, transverse median area sharply defined. Colour pale grey. Central space roundly elliptical, 0·025 to 0·03 mm. broad. Markings conspicuous, distant, narrow costæ, those converging to the processes often anastomosing near the latter, on the transverse area delicate striæ, straight or slightly curved, and diverging from the central space; at its centre a few diverging, sometimes anastomosing radial costæ. Processes 2, rounded, from 0·035 to 0·04 mm. broad, outer edge irregular, with border broad and central portion distinctly punctate.—*A. sculptus* var. *permagna* Witt, Sch. Atl., pl. cxvii. figs. 5-7.

Habitat: Loc. ? (Griffin!); Iquique (Kitton!).

*A. cælatus* Bail. Smiths. Contrib., 1853, p. 6, pl. figs. 3, 4.

Roundly elliptical, major axis from 0·04 to 0·12 mm.,  $1\frac{1}{5}$  to  $1\frac{1}{4}$  times minor. Surface rising gently to processes, transverse median areas distinct, with outer ends broad, rounded, sharply defined. Colour pale grey. Central space rounded or obtusely angular, rarely rectangular, sometimes indistinct, 0·0075 to 0·0125 mm. broad. Markings costate, those converging to the processes, sometimes less prominent than those proceeding from their outer side to the border, the latter straight in line of processes, elsewhere concave towards that line; on the transverse area least evident, sometimes punctate, straight or flexuous, and diverging; near the outer ends of this area anastomosing between it and the border conspicuous, convex towards the processes. Processes 2, rarely 3, rounded, 0·0075 to 0·0175 mm. broad, their circumference sometimes irregular.—Ralfs in Pritch. Inf., p. 845; Grev. Trans. Mic. Soc. Lond., 1863, p. 44, pl. ii. fig. 7; Sch. Atl., pl. xxxii. figs. 14, 15; Pant. Fossil. Bacil. Ung., p. 55, pl. xix. fig. 173; H. L. Smith, Diat. Spec. Typ., No. 54. *A. Smithii*,

Jan. Abh. Schl. Ges. väter. Cult., 1861, p. 163, pl. ii. fig. 9.  
*A. Gregorii*, Jan. ibid., pl. ii. fig. 12. *A. calatus* forma *triocellata*,  
 Pant. ibid., p. 56, pl. xxviii. fig. 279.

Habitat: Moron deposit (Greville! Griffin!); Californian guano (Greville! Griffin!); Patos Island guano (Greville!); Newcastle deposit, Barbadoes (Firth!); Santa Monica deposit (Rae! Kinker! Griffin! Deby! Grove!); Szent Peter deposit (Pantocsek! Kinker! Doeg!); Oamaru deposit (Grove!); Santa Marta deposit (Doeg!); Kékkö deposit (Pantocsek! Kinker!); Kerguelen (H. L. Smith!); Arran (Greville! Gregory!); Bass Straits (Johnson!); Cagayan Island, Sulu Archipelago (O'Meara!); Woodlark Island (Roberts!); coral washings, Mauritius (Doeg!); shell cleanings (no locality) (Doeg!); Holothurians, Java and California (Kinker!); Yokohama mud (Kinker! Griffin!); West Coast South America (Kinker!); Rembang Bay, Colon, Samoa, Vera Cruz, China (in Holothurians), Monterey and Port Seguro (Deby!); San Pedro, Georgia Swamps, New South Wales, King George's Sound, Sumatra, and Tamatave (Grove); Japan (Firth!); Bahía (Kitton! Grove).

Var. *aucklandica* Grun., Sch. Atl., pl. lxvii. fig. 13.—Surface with broader transverse median area. Central space elliptical, major axis in line of processes, and about twice minor. Markings on transverse median area irregular, obscurely anastomosing. Border narrow, definite, with delicate uniform striæ.—*A. aucklandicus* Habirsh. Cat. Diat., § *Auliscus*. *A. calatus* var., Sch. Atl., pl. lxvii. fig. 12.

Habitat: Auckland Island (Grunow).

Var. *strigillata*, Sch. Atl., pl. xxxii. figs. 24–26.—Rarely unequally and obtusely angular, major axis 0·0625 to 0·165 mm,  $1\frac{1}{4}$  to  $1\frac{1}{6}$  times minor. Central space obtusely angular, its long axis sometimes slightly oblique to line of processes. Markings, the costæ on transverse median area continuous to border; apiculi evident, on this area most crowded around and sometimes confined to its outer edge, more rarely few and large. Processes more irregular on outer than on inner side.—Grev., Trans. Mic. Soc. Lond., 1863, pl. ii. figs. 5, 6.

Habitat: Patos Island guano (Johnson!); Peruvian guano (Browne!); Californian guano (Johnson!); Lamlash, Arran (Gregory!); Iquique (Hardman!); China, from Holothurians (Macrae!); Balearic Islands\* (Weissflog!); Bahía (Hardman!†); Yokohama (Grundler).

Var. *deliculata*—Major axis 0·05 to 0·08 mm., about  $1\frac{1}{3}$  to  $1\frac{1}{4}$  times minor. Surface almost flat, with transverse median area evident. Markings faint or indistinct, striæ minute; apiculi around ends of transverse area. Processes small.—Pl. XV. fig. 5.

Habitat: Yokohama (Hardman!); China (Macrae!); Oamaru deposit (Grove!).

\* This specimen has been associated by Grunow with *A. sculptus*.

† In the Collection of Mr. Julien Deby.

Var. *major*, Sch. Atl., pl. lxvii. fig. 11.—Major axis 0·14 to 0·15 mm., about  $1\frac{1}{3}$  times minor. Central space rounded or bluntly angular. Markings punctate on transverse median areas, in strands, widening towards their outer ends, narrow and in uniformly curved sigmoid or flexuous bands towards the processes, interspaces between costæ at border minutely punctate.—*A. sculptus*, var. *permagna* Witt, Sch. Atl., pl. cxvii. fig. 4.

Habitat: Ægina (Ehrenberg); Santa Monica deposit (Rae!); Mejillones, Bolivia (Witt); Moron deposit (Greville!).

Var. *constricta*.—Major axis 0·075 mm., about  $1\frac{1}{4}$  times minor. Surface with transverse median areas short and narrow. Central space round, 0·01 mm. broad. Markings costate, those converging to the processes as distinct as those passing to the border, on the transverse areas more delicate. Processes 2, about midway between central space and border.—Pl. XV. fig. 8.

Habitat: Moron deposit (Johnson!); Tamatave (Grove!); Mejillones (Deby!).

Var. *impressa*.—Major axis 0·0575 to 0·065 mm., about  $1\frac{1}{2}$  to  $1\frac{1}{2}$  times minor. Surface rising but slightly near the processes, the transverse median areas indistinct or absent. Markings costate, those passing to the border flexuous or simply curved, sometimes anastomosing, their inner ends distinct, passing inwards to the central space.—Pl. XV. fig. 9.—*A. sculptus* var., Leud.-Fort. Diat. Ceyl., pl. vii. fig. 67.

Habitat: West Port Bay (O'Meara!); Arran Island (Greville!).

Var. *late-costata*, Sch. Atl., pl. xxxii. figs. 16–20.—Major axis 0·0425 to 0·0625 mm., about  $1\frac{1}{2}$  to  $1\frac{1}{6}$  times minor. Surface with transverse median areas sometimes narrow and short. Markings costate, placed at wide intervals, at outer ends of the transverse areas an irregular faint reticulum and sometimes minute apiculi.—*A. sculptus* var., Leud.-Fort. Diat. Ceyl., pl. vii. fig. 66.

Habitat: Bass Straits (Johnson!); Newcastle deposit, Barbadoes (Doeg!); Yokohama (Hardman!); Holothurians, Java (Kinker!); Campeachy Bay (Grundler).

Var. *mergens*.

*A. cælatus* var., Sch. Atl., pl. xxxii. figs. 12–13, 23.

Major axis 0·07 to 0·09 mm., about  $1\frac{1}{3}$  times minor. Surface with outline of transverse median areas indefinite. Central space roundly elliptical, long axis in line of processes, 0·01 mm. broad. Markings: the lines converging to the processes uniformly curve l, closely placed, those diverging from outer ends of transverse areas to border often more distinct than others nearer the processes, transverse areas punctate.

Habitat: Moron deposit (Weissflog); Oamaru deposit (R. Rattray!); Tamatave (Grove!); King George's Sound (Grove!); Port Lincoln, Australia (Schmidt).

Var. *picta*.—Major axis 0·12 mm.,  $1\frac{1}{2}$  times minor. Surface

with transverse median areas wide, extending almost to the processes. Central space minute, 0·003 mm. broad, elongated obliquely to direction of processes. Markings on transverse areas delicate, radiating, punctate striæ, a distinct irregular reticulum around their outer edge, on peripheral side of processes short irregular costæ tapering outwards, a few reaching the border.—Pl. XV. fig. 7.

Habitat: Yokohama (Hardman!).

Var. *protuberans*.—Major axis 0·1025 mm., about  $1\frac{1}{9}$  times minor. Central space rounded, 0·01 mm. broad. Markings punctate on the transverse areas and disposed in strands separated by hyaline interspaces with irregular edges, the strands converging to the processes distinct all round the latter, almost straight about their middle, but sharply curved at their inner ends. Processes 2, round, 0·01 mm. broad.—Pl. XVI. fig. 6.

Habitat: 'Challenger' trawl, 22nd January, 1875, 100 to 150 fathoms (Rae!).

Var. *tenuis*.—Major axis 0·0575 to 0·115 mm., about  $1\frac{1}{10}$  times minor. Surface with transverse areas merging gradually into those rising to the processes, and having the outer ends broad, sharply defined. Central space round, 0·075 to 0·015 mm. broad. Markings minute apiculi sometimes on striæ converging to processes, and upon the transverse areas. Processes elliptical, 0·0075 to 0·01 mm. broad.—Pl. XVI. fig. 3.

Habitat: Singapore (Doeg!); extinct crater, Cagayan Island, Sulu Archipelago (O'Meara!); from Holothurians, China (Deby!).

Var. *mutabilis*.—Major axis 0·1 to 0·125 mm.,  $1\frac{1}{6}$  to  $1\frac{1}{12}$  times minor. Colour dark brown to bluish. Central space angular or elliptical, the angles sometimes extending almost to the processes, 0·015 mm. broad. Markings distinct, on the transverse areas irregular, granular, in indistinct radiating and diverging rows, around the border the striæ closely placed, with irregular outlines. Processes 2, irregularly elliptical, 0·02 mm. broad, their circumference with minute irregularities.—Pl. XV. fig. 6.

Habitat: Yokohama (Kitton\*).

## § 11. AREOLATI.

Transverse median areas, when present, with indistinct outer ends. Markings irregular, pearly over general surface, or only on more limited areas. Processes large.

### *Auliscus fractus* Grove and Kitton in litt.

Roundly elliptical, major axis 0·105 mm., about  $1\frac{1}{2}$  times minor. Surface rising but slightly to the processes, slope at border gentle. Colour smoky grey. Central space round, 0·015 mm. broad. Markings prominent, unequal areolæ, separated by narrow clear lines, converging between central space and processes, elsewhere the rows straight or

\* In the Collections of Mr. E. Grove and Mr. Julien Deby.

sigmoid near the converging lines. A band of larger subequal areolæ adjacent to processes. Processes 2, elliptical, 0·03 mm. broad, separated from border by a single band of areolæ. Central portion convex, hyaline.—Pl. XIV. fig. 5.

Habitat: King George's Sound (Grove!).

*A. mirabilis* Grev. Trans. Mic. Soc. Lond., 1863, p. 47, pl. ii. fig. 11.

Elliptical, major axis 0·05 to 0·145 mm., from  $1\frac{1}{4}$  to  $1\frac{1}{7}$  times minor. Surface rising gently at the processes, transverse median areas with sides distinct but outer ends inconspicuous. Colour pale grey. Central space quadrangular, rarely rounded, from 0·005 to 0·015 mm. broad. Markings minute punctate; strands converging to the processes irregular, distinct, sometimes interrupted; on the transverse areas radial, diverging, sometimes scabrous; around the border a single band of larger lanceolate areolæ, with acute peripheral, and more rounded central ends. Processes 2, from 0·01 to 0·025 mm. broad, with broad irregular border, and hyaline central portion.—Sch. Atl., pl. lxxxix. figs. 10–13.

San Diego specimens (Grundler), and some of those from Santa Marta and Santa Monica have the markings more interrupted and less prominent than San Pedro valves.

Habitat: Santa Marta deposit (Doeg!); Monterey (Firth! Griffin!); Santa Monica deposit (Kinker! Cleve, Firth\*); Santa Maria deposit (Rae!\*); San Pedro (Grove!); Los Angeles (Hardman! †).

## § 12. NOBILISSIMI.

Transverse median areas distinct. Markings prominent between the lines converging to processes, and in strands widening towards border; on transverse areas sometimes plumose. Processes large, high.

### *A. subcælatatus* sp. n.

Elliptical, major axis 0·1125 mm., about  $1\frac{1}{8}$  times minor. Surface rising slightly to processes, and sloping gently from ends of transverse median areas to border. Colour pale smoky grey. Central space irregularly hexagonal; those sides on the transverse areas most closely placed, 0·015 mm. apart, the acute angles extending close to the processes. Markings punctate, forming delicate striæ around the processes; beyond these, 4 or 5 unequal strands separated by narrow, wavy, clear bands passing obliquely to the edges of the transverse areas, similar but more uniform strands diverging from outer ends of these areas to the border; upon the transverse areas irregular, diverging, plumose, punctate lines. Processes 2, less convex on inner than on outer side, 0·0225 mm. broad.

Habitat: Oamaru deposit (Rae!)

\* In the Collection of Dr. Griffin.

† In the Collection of Mr. Julien Deby.

*A. oamaruensis* Grove & Sturt, Journ. Quek. Mic. Cl., 1887, p. 10, pl. iii. fig. 13.

Roundly, subregularly, elliptical, major axis from 0·15 to 0·23 mm.,  $1\frac{1}{5}$  to  $1\frac{1}{9}$  times minor. Surface with an elevated broadly obcordate area between central space and processes, having the outer edge sharply defined; the transverse areas with edges sometimes less abrupt, outer ends rounded at about  $\frac{7}{9}$  of radius from centre, and sides uniformly concave. Colour pale brownish yellow, alternating with hyaline strands. Central space diamond-shaped, large, hyaline. Markings granular, closely aggregated in strands with hyaline interspaces, the strands between the edges of the obcordate and transverse areas distinct, the four sets together diamond-shaped; those on the transverse areas radial, expanding towards border, almost straight at the middle, elsewhere convex towards the processes. Processes 2, large, rounded, first expanding to median widest portion, and from this rounding to apex; from 0·02 to 0·03 mm. broad.—Sch. Atl., pl. cxvii. fig. 2, pl. cxxv. fig. 1.

Habitat: Oamaru deposit (Grove & Sturt! R. Rattray! Hardman! Rae!).

*A. intermedius* Grove & Sturt in litt.

Elliptical, major axis 0·1125 mm., about  $1\frac{1}{8}$  times minor. Surface rising from centre towards processes, a transverse area at right angles to the line of processes, distinct, with outer ends rounded at about  $\frac{3}{4}$  of radius from the centre, outside of this the slope to the border gentle. Colour light smoky grey. Central space rounded, about 0·0125 mm. broad. Markings granular, the strands separated by hyaline spaces, those converging to the processes almost straight or slightly concave outward towards the outer, sharply convex outward towards the inner, ends, elsewhere almost straight, elongately obconical, towards the processes confluent laterally. Border indistinct, striæ delicate, 8 in 0·01 mm. Processes 2, subcircular, about 0·015 mm. broad, with the border opaque.—Pl. XII. fig. 8.

Habitat: Oamaru deposit (Grove!).

Var. *simplex*.—Major axis 0·08 mm., about  $1\frac{1}{10}$  times minor. Markings: the strands narrower and of more uniform width, those converging to the processes more concave towards the central space, the inner ends of those on transverse median areas more distinct, around each process an irregular slightly angular band of large unequal granules. Processes round, simple, 0·015 mm. broad, their circumference with minute irregularities.—Pl. XVI. fig. 5.

Habitat: Oamaru deposit (Rae! Grove!).

§ 13. SIGNATI.

The central portion of the valve sometimes distinct, transverse areas indistinct, short or reaching close to border. Markings delicate close striæ around border, convex towards processes, sometimes punctate.

*A. sublævis* Grun. MS.

Irregularly elliptical, major axis  $0\cdot045$  mm., about  $1\frac{1}{17}$  times minor. Surface almost flat, a dark indistinct band between processes and close to border, slope at border gentle. Colour pale grey. Central space round, about  $0\cdot0025$  mm. broad, indistinct. Markings punctate, minute, striæ just visible on central side of processes. Processes 2, plano-convex, or outer side protuberant,  $0\cdot01$  mm. broad.—Pl. XII. fig. 7.

Habitat: Moron deposit (Weissflog!)

*A. lucidus* sp. n., Sch. Atl., pl. xxxi. figs. 10, 12.

Elliptical, major axis  $0\cdot15$  mm.,  $1\frac{1}{3}$  times minor. Surface with central portion slightly elevated, its outer edge faint, convex outwards, at about  $\frac{2}{3}$  of semi-minor axis from central space and passing round the outer side of the processes. Colour hyaline, central space round, indistinct. Markings obscure, a few delicate striæ converging to the processes somewhat more evident. Processes 2, round,  $0\cdot02$  mm. broad, placed near middle of semi-major axis, their circumference distinct, central portion punctate.

Habitat: Gulf of Carpentaria (Weissflog! Grundler).

*A. ovalis* Arnott in Pritch. Inf., p. 846.

Elliptical, sometimes more convex on one side than on the other, or oval, major axis  $0\cdot08$  to  $0\cdot125$  mm., about  $1\frac{1}{2}$  to  $1\frac{3}{4}$  times minor. Surface rising slightly from the centre to the processes, transverse median areas extending to about  $\frac{4}{5}$  of radius, with outer ends rounded, sometimes indistinct and closer to border, outside of this slope to border gentle. Colour pale grey. Central space roundly elliptical, from  $0\cdot008$  to  $0\cdot0125$  mm. broad. Markings delicate, closely placed striæ, straight in direction of axis of transverse areas, sigmoid about sides of these areas, the peripheral curves convex towards the processes; apiculi few between central space and processes, and on transverse median areas, chiefly at outer ends of latter, sometimes absent. Processes 2, elliptical or obtusely triangular, about  $0\cdot0225$  mm. broad.—Grev. Trans. Mic. Soc. Lond., 1863, p. 47, pl. iii. fig. 12; Sch. Atl., pl. xxx. figs. 16, 17, pl. cxxv. fig. 3; H. L. Smith, Sp. Diat. Typ. No. 55.

Some Oamaru valves have the striæ converging to the processes specially well defined.

Habitat: Iquique (Hardman!); Pisagua, Peru (H. L. Smith! Weissflog!); Peruvian guano (Griffin! Grove); Islay, Peru (Griffin!); Algoa Bay guano (Greville!); South African guano (Greville!); Japan oysters (Rae!); Cape of Good Hope (Macrae! Weissflog!); Oamaru deposit (Grove!); Santa Monica deposit (Kinker!).

*A. praelatus* sp. n.

Elongately elliptical or suboval, major axis 0·125 to 0·15 mm., from  $1\frac{1}{3}$  to  $1\frac{1}{4}$  times minor. Surface rising gently from central space to processes, transverse median areas distinct, their outer ends rounded at about  $\frac{3}{4}$  of radius from centre, outside of this the slope to border gentle. Colour pale grey, darker towards centre. Central space rounded, 0·015 mm. broad. Markings, distinct striæ with clear interspaces, those converging to the processes uniformly curved but replaced close to the processes by short delicate striæ 8 in 0·01 mm.; most crowded on the transverse median area, beyond this straight, in direction of axis of this area, elsewhere convex towards processes, at border and near the processes more pruinose, often interrupted or represented by irregular scattered granules; apiculi inconspicuous, chiefly on transverse median areas. Processes 2, large, roundly elliptical, major axis oblique, 0·03 mm. long, border finely striated.

Habitat: Peruvian guano (Rae! Griffin!); Pisagua (Kitton!\*); Islay, Peru (Griffin!); Mejillones, Bolivia (Firth!).

*A. caribæus* Cleve, Sch. Atl., pl. lxxvii. figs. 9, 10.

Subcircular, diam. about 0·05 mm. Surface with indistinctly defined transverse median areas, processes low. Colour? Central space circular, distinct, about 0·0075 mm. broad. Markings punctate and irregular, but distinct on transverse areas, striæ converging to the processes inconspicuous, beyond the central areas radial and straight to border. Processes rounded, about 0·013 mm. broad, with broad border.

Habitat: Darien (Schmidt).

*A. macraeanus* Grev., 'Trans. Mic. Soc. Lond., 1863, p. 51, pl. iii. fig. 18.

Circular or roundly elliptical, major axis 0·0625 to 0·115 mm., about  $1\frac{1}{7}$  times minor. Surface rising slightly from the centre to processes, elsewhere almost flat, transverse median areas short, indistinct. Colour pale grey. Central space circular, 0·005 to 0·01 mm. broad. Markings delicate striæ, those converging to the processes most evident, elsewhere radial and diverging; apiculi sometimes evident on transverse areas, and on a narrow band close to border. Processes 2, large, about 0·0325 mm. broad, circular.—Sch. Atl., pl. xxxi. fig. 5.

Habitat: Ceylon (Macrae!); Oamaru (Rae!); Ashley River, North America (Weissflog!).

*A. Grevillei* Jan., Abh. Schl. Ges. väter. Cult., 1861, p. 163, pl. ii. fig. 11.

Elliptical, rarely oval, major axis from 0·12 to 0·165 mm., about  $1\frac{1}{3}$  to  $1\frac{1}{4}$  times minor. Surface rising slightly from centre to processes,

\* In the Collection of Dr. Griffin.

transverse median areas distinct, with outer ends rounded about  $\frac{3}{5}$  of radius from centre, slope towards border gentle. Colour pale grey, darker at outer ends of transverse areas. Central space round, distinct, 0.01 to 0.015 mm. broad. Markings delicate striæ, those converging to processes most evident, the others almost straight or slightly convex towards processes at border; apiculi numerous, irregular, most prominent at outer ends of transverse areas. Processes 2, roundly elliptical, from 0.025 to 0.325 mm. broad.

*Girdle aspect*\* showing obliquely truncate processes with margin slightly protuberant. Girdle hyaline, with median line parallel to its edges, 0.025 mm. broad in valve 0.115 mm. in diam.—Sch. Atl., pl. xxx. fig. 15.

Habitat: Peruvian guano (Firth! Rae! Kitton!); Mejillones guano (Kitton!); Pisagua (Weissflog! Kitton!\*); Mejillones, Bolivia (Firth! Bessels! †); Pabellan de Pico guano (Cleve).

#### § 14. RETIFORMES.

A reticulum over entire surface or confined to central or peripheral portions, sometimes indistinct. Markings obscure, delicate striæ or costæ, or forming punctate interrupted strands. Interspaces hyaline. Apiculi obscure or absent.

##### *A. textilis* Sch. Atl., pl. lxxxix. fig. 9.

Subcircular, diam. 0.095 mm. Surface sloping gently to border. Central space circular, distinct, 0.015 mm. broad. Markings a delicate reticulum with minute irregular meshes, having delicate points at the angles. Border distinct, with irregular radial or somewhat oblique lines. Processes circular, 0.019 mm. broad, central portion relatively small, hyaline.

Habitat: Santa Monica deposit (Schmidt).

##### *A. subreticulatus*.—*A. pruinosis* var. *subreticulata* Grun., Sch. Atl., pl. lxxxix. figs. 5, 6.

Elliptical, major axis 0.075 to 0.13 mm.,  $1\frac{1}{6}$  to  $1\frac{1}{5}$  times minor. Surface flat or central portion sometimes slightly elevated, with outer edge distinct and convex between processes. Colour pale grey or smoky grey. Central space rounded, 0.01 to 0.0175 mm. broad, distinct. Markings evident, striæ converging to the processes, those on intermediate areas indistinct, straight, radial, a reticulum with unequal meshes well defined; apiculi absent. Processes 2, round or elliptical, 0.0175 to 0.0275 mm. broad, their circumference sometimes rough.

Habitat: Santa Monica deposit (Rae! Firth! Griffin! Cleve!); Crescent City, California (Weissflog! Griffin!); Los Angeles (Hardman! †).

\* Also in the Collection of Dr. Griffin and Mr. E. Grove.

† In the Collection of Dr. Griffin. ‡ In the Collection of Mr. Julien Deby.

Var. *decipiens*. — Irregularly elliptical or suboval, major axis 0·0575 mm., about  $1\frac{1}{4}$  times minor. Surface with transverse median areas indistinct, the outer ends about half of semi-minor axis from centre. Markings minute, punctate, a few short faint irregular striæ converging to the processes; apiculi indistinct or absent. Processes 2, round, 0·0075 mm. broad.

Habitat: Ceylon (Weissflog!); Los Angeles (Hardman!)

*A. reticulatus* Grev. Trans. Mic. Soc. Lond., 1863, p. 46, pl. ii. fig. 10.

Roundly elliptical, major axis 0·0725 mm., about  $1\frac{1}{3}$  times minor. Surface rising gradually from centre to processes, the central portion sharply defined, extending to outer side of processes, widest opposite the central space, reaching to  $\frac{4}{5}$  of radius from centre. Colour pale grey. Central space round, distinct, 0·0125 mm. broad. Markings evident, striæ converging to the processes sometimes with minute lateral protuberances, rarely anastomosing on the central portion, but between the converging sets more faint with frequent anastomoses, around the border distinct, straight, or slightly bent, distant. Processes 2, small, outer end rounded, about 0·01 mm. broad.—Sch. Atl., pl. xxx. figs. 1–3. *A. reticulatus* var., Sch. Atl., pl. xxx. fig. 4.

Habitat: Zanzibar (Weissflog!); Bass Straits (Johnson!); scrapings from *Haliotis* shells, Peru (Grove!); Holothurians, California (Kinker!); Red Sea (Grunow); Peru and Amboyna (Grove).

Var. *quadrisignata* Sch. Atl., pl. xxx. fig. 5.—Major axis 0·05 mm., about  $1\frac{1}{3}$  times minor. Markings: striæ converging to processes less evident, reticulum on transverse areas faint but evident, on 2 or 4 small subsymmetrical areas more prominent.

Habitat: Campeachy Bay (Weissflog!); Auckland (Cleve).

Var. *capensis* Sch. Atl., pl. xxx. fig. 6.—Major axis 0·07 mm., about  $1\frac{1}{4}$  times minor. Surface with central portion extending to middle of processes, its protuberant lateral portion nearer the border. Markings: striæ converging to the processes more distant and irregular, a reticulum faint and only on lateral protuberant parts of central portion. Processes oval, long axis directed straight or obliquely towards centre.

Habitat: Cape of Good Hope (Schmidt).

*A. compositus* Sch. Atl., pl. xxx. fig. 9.

Roundly elliptical, major axis 0·1325 mm., about  $1\frac{1}{2}$  times minor. Surface rising slightly towards the processes, elsewhere almost flat; a distinctly defined, irregularly oval, subsymmetrical, median area, extending to, and with long axis in line of, processes, its minor axis from  $\frac{1}{2}$  to  $\frac{3}{5}$  of that of the valve. Colour light smoky grey. Central space circular, about 0·015 mm. broad. Markings: around central space a band of large, somewhat obconical, unequal, mostly 3- or 4-sided areolæ, reaching from  $\frac{1}{2}$  to  $\frac{3}{5}$  of minor axis of median area, on the remainder of this area an irregular reticulum with meshes,

large, unequal, mostly 4-sided, outside of it the radial lines distinct, slightly concave towards processes, with transverse anastomosing lines, few irregular. Processes 2, outer edge close to border, mammillate, elliptical, breadth 0·02 mm.

Habitat: Manilla (Hardman!); locality unknown (Weissflog!).

*A. Schmidtii* Gründl., Sch. Atl., pl. xxx. fig. 7.

Irregularly elliptical, lobate, major axis 0·1425 mm., about  $1\frac{1}{2}$  times minor. Surface with central portion slightly elevated, its outer edge irregularly rounded, distinct, not reaching processes, but extending to about  $\frac{3}{5}$  of radius from centre. Colour pale grey. Central space inconspicuous, rounded, about 0·005 mm. broad. Markings on central portion faint, irregular, distant, striæ forming an irregular reticulum, most distinct towards its outer edge, those converging to the processes short, distinct, at wide unequal intervals on the outer side of the processes, a distinct reticulum sometimes present but not reaching border, the striæ around the border straight or somewhat convex towards processes, distinct, rarely closely disposed. Processes 2, rounded, about 0·015 mm. broad, at some distance from border.

Habitat: From Holothurians, Sumatra (Deby!); King George's Sound (Grove!); Campeachy Bay (Schmidt).

*A. opulentus* sp. n.

Circular, diam. 0·0875 mm. Surface with outer edge of central portion indistinct, concave between processes. Colour pale smoky grey. Central space round, distinct, 0·0125 mm. broad. Markings minute, punctate, forming distinct strands, diverging from central space, sometimes irregular with hyaline interspaces, the striæ converging to processes irregular, outside of central portion narrow hyaline lines between the punctate areas, the striæ around the border delicate, radial; reticulum absent. Processes 4, unsymmetrical, somewhat unequal, from 0·0125 to 0·0175 mm. broad.—Pl. XIV. fig. 4.

This form has been united by Grunow with *A. cælatrus* as forma *quadriocellata*, but it bears little affinity to this species. It is nearer *A. speciosus*.

Habitat: Santa Monica deposit (Weissflog!).

*A. speciosus* Sch. Atl., pl. lxxx. fig 5.

Obtusely quadrangular, diam. 0·15 mm. Surface with central area flat, its outer edge distinct, irregular, concave outwards between the processes at about  $\frac{2}{3}$  of radius from centre. Elevations beneath processes high. Colour pale smoky grey. Central space round, 0·0225 mm. broad. Markings punctate, distinct, on evident strands diverging and widening outwards from central space, and separated by hyaline interspaces, less distinct around the border, delicate striæ present around base of processes, a reticulum with unequal meshes well marked outside of central area and sometimes around processes,

the meshes smallest close to border. Processes 4, roundly elliptical, about 0.02 mm. broad.—Sch. Atl., pl. cviii. fig. 3.

Habitat: Santa Monica deposit (Rae! Gray! Kinker! Kitton!).

*A. subspeciosus* sp. n.

Elliptical, major axis 0.1125 mm., from  $1\frac{1}{4}$  to  $1\frac{1}{3}$  times minor. Surface with central portion between processes somewhat elevated, oval or irregularly diamond-shaped, outer edge distinct, sometimes irregular, beyond this slope to border gentle. Colour pale grey. Central space circular, 0.015 mm. broad, distinct. Markings punctate, minute, in interrupted, narrow, irregular strands radiating from central space, an irregular reticulum about outer edge of central portion, beyond this the striæ radial or oblique and curved, those converging to the processes irregularly bent and irregular. Processes 2, elliptical, 0.015 mm. broad, the outer ends convex, high.—Pl. XIV. fig. 3.

Habitat: Santa Monica deposit (Rae! Gray! Deby! Griffin!); Los Angeles (Hardman!).

§ 15. SPECIES DUBIÆ VEL EXOLUSÆ.

*A. (?) gigas* Ehrb., Mon. Ber. Ak., 1844, p. 77.—Fragmentary, sides slightly protuberant opposite process and about  $90^\circ$  from this. Central space absent. Markings distinct, distant, curved lines radiating and diverging towards tumid border, the latter bearing sigmoid lines separating similarly curved rows of granules. Process prominent, convex, elliptical, around the central portion a narrow granulate band, and outside of this a broader band similar to the tumid border.—Ehrb. Mikrog., pl. xix. fig. 63; Ralfs in Pritch. Inf., p. 846; Grev. Trans. Mic. Soc. Lond., 1863, p. 52. *Coccinodiscus Auliscus* Kütz., Sp. Alg., p. 126.

Habitat: Ægina (Ehrenberg).

*A. americanus* Ehrb., Mikrog., pl. xxxiii. 14, fig. 2.—Circular. Central space large irregularly quadrate, with rounded angles at processes and middle of intervening area. Markings distinct, distant, lines straight at right angles to line of processes, elsewhere concave towards the processes. Processes 2, subcircular, their border wide.—Ralfs in Pritch. Inf., p. 846; Grev. Trans. Mic. Soc. Lond., 1863, p. 52.

Probably, as pointed out by Ralfs, this species is the same as *A. sculptus* W. Sm.

Habitat: Brackish marshes near Norwich, Connecticut (Ehrenberg).

*A. cylindricus* Ehrb., Mon. Ber. Ak., 1843, p. 271.—Of this species no figure has been published. The frustule is said to be cylindrical, often tibia-like, the disc on each side orbicular, plain, its margin and middle portion marked by various radiating lines, the apertures (= processes) 2, oblique, large, but scarcely raised above the margin. Diam. 0.045 to 0.095 mm. Specimens so named were observed by Ehrenberg from Ems mud near Weimar, from marine

mud at Norderney, from Jahde mud near Hochsiel Jeverland, and from sand at the mouth of the Tajo.—Conf. Ralfs in Pritch. Inf., p. 846; Grev. Trans. Mic. Soc. Lond., 1863, p. 52.

*A. polystigma* Ehrb., Mon. Ber. Ak., 1844, p. 77, has not been adequately defined. Ehrenberg only noted that the valve had “cellules or apiculi” equal, small, disposed without order, and not contiguous. His specimens were from Ems mud near Weimar. Kützing added that it differed from *Coscinodiscus radiolatus* in having a little larger radiating markings—about 7 instead of 9 in 0·01 mm.—converging in two lateral whorls, and recorded it as fossil in North America. It is identical with *Coscinodiscus polystigma* Ehrb., Mon. Ber. Ak., 1843, p. 271, and *Auliscus polystigmus* Ralfs, in Pritch. Inf., p. 846. Conf. Grev. Trans. Mic. Soc. Lond., 1863, p. 52.

*A. fulvus* Raben., Flor. Europ. Alg. aq. dulc, p. 320, is *Eupodiscus fulvus* W. Sm. (Syn. Brit. Diat., i. p. 24), and was correctly referred by Ralfs to *Actinocyclus*.

I am unacquainted with *A. granulatus* Bail. and *A. quadriceps* Bail., which occur, according to Habirshaw, in the collection of Prof. Bailey, but remain *nomina nuda*.

#### ARTIFICIAL KEY.

- |  |                     |
|--|---------------------|
| 1. Processes six, two large mammillate, two smaller at ends of transverse area, and two at considerable unequal distances from the corresponding sides of the large ones. Markings pruinose striæ; a clear curved band at outer ends of transverse areas .. .. . | <i>dissimilis.</i>  |
| No such processes .. .. .  | 2                   |
| 2. A clear concavo-convex space on inner side of each process ..   | <i>lacunosus.</i>   |
| Two clear spaces between each process and the central space, that nearer the centre long, narrow .. .. .   | <i>fenestratus.</i> |
| No such clear areas .. .. .  | 3                   |
| 3. Valve with three distinct zones. Markings costate, star-shaped at centre .. .. .  | <i>stelliger.</i>   |
| No such zones .. .. .  | 4                   |
| 4. Markings areolate, unequal, large, pearly; processes low, broad. Transverse median areas obscure .. .. .  | <i>fractus.</i>     |
| Markings areolate, unequal, large, pearly; processes low, broad. Transverse median areas prominent, obovate .. .. .  | <i>convolutus.</i>  |
| No such markings .. .. .   | 5                   |
| 5. A marginal band of large lanceolate markings .. .. .  | <i>mirabilis.</i>   |
| No such marginal band .. .. .  | 6                   |
| 6. Striæ short, distant, flexuous, irregular but distinct .. ..  | <i>pressus.</i>     |
| No such striæ .. .. .  | 7                   |
| 7. Processes close to the central space .. .. .  | 8                   |
| “ much nearer border .. .. .   | 9                   |
| 8. Apiculate .. .. .   | 10                  |
| Non-apiculate .. .. .  | 11                  |
| 10. Striæ converging to the processes evident, elsewhere obscure ..  | <i>accedens.</i>    |
| Markings obscure throughout .. .. .  | <i>propinquus.</i>  |
| 11. Markings minute, round, granular, most evident towards border, rows radial .. .. .   | <i>Rattrayi.</i>    |
| “ large round granules, rows inconspicuous, radiating and diverging .. .. .  | <i>robustus.</i>    |
| 9. Central space diamond-shaped .. .. .  | 12                  |
| “ “ not diamond-shaped .. .. .   | 13                  |
| 12. Transverse areas absent .. .. .  | 14                  |
| “ “ present .. .. .  | 15                  |

14. Markings obscure. Processes 4 .. .. .	<i>parvulus.</i>
"    minute, punctate. Processes 2, close to major axis.	<i>nitidus.</i>
15. Transverse areas faint .. .. .	16
"    "    distinct .. .. .	17
16. Apiculate .. .. .	18
Non-apiculate, a delicate reticulum with small meshes evident	<i>gracillimus.</i>
18. Apiculi aggregated on a narrow band around each process ..	<i>pectinatus.</i>
"    few, minute, between outer edges of transverse areas	
and the areas between the centre and processes ..	19
19. Transverse area narrow, with clavate outline .. .. .	<i>eximius.</i>
"    "    widening towards border with irregular outline	<i>antiquus.</i>
17. Transverse areas, with concave or straight ends and obscure	
markings .. .. .	<i>insignis.</i>
"    "    with convex ends and evident markings;	
pearly areolæ forming a marginal band	
and V-shaped lines on the central side of	
each process .. .. .	<i>decoratus.</i>
Appearance otherwise .. .. .	20
20. Markings scabrous. Transverse areas narrow towards the	
centre, their outer ends suddenly expanding,	
rounded .. .. .	<i>hardmanianus.</i>
"    delicate. Transverse areas expanding widely out-	
wards. Processes large, high, with sides concave	
and apices convex .. .. .	<i>Biddulphia.</i>
"    delicate. Convolute anastomosing clear lines be-	
tween transverse areas and those extending	
between central space and processes .. .. .	<i>intestinalis.</i>
13. Central space elongately elliptical. Transverse areas oblique	
to direction of processes .. .. .	<i>raeanus.</i>
"    "    indefinite. Transverse areas defined by a clear	
band. Markings small, round, granular, in	
radial rows beyond this band .. .. .	<i>pauper.</i>
"    "    round or angular .. .. .	21
21. No transverse median areas .. .. .	22
Transverse median areas present .. .. .	23
22. A reticulum .. .. .	24
Reticulum almost confined to central portion of valve .. ..	25
No reticulum .. .. .	26
24. Reticulum with small subregular meshes, central portion of	
valve not differentiated from peripheral .. .. .	<i>textilis.</i>
"    coarse, irregular, outline of central portion extending	
between sides of processes faint .. .. .	<i>subreticulatus.</i>
"    irregular, distinct only outside of sharply defined	
central portion. Processes 4 .. .. .	<i>speciosus.</i>
25. Central portion of valve distinct .. .. .	27
"    "    "    indistinct, regularly rounded, a re-	
ticulum with small delicate meshes	
chiefly on its outer part .. .. .	<i>spectabilis.</i>
27. Central portion regularly rounded, not reaching central side	
of processes .. .. .	<i>Schmidtii.</i>
"    "    extending round outer side of processes and	
protruding opposite the central space ..	<i>reticulatus.</i>
"    "    elliptical, not protruding opposite the central	
space .. .. .	<i>compositus.</i>
26. Central portion indistinct .. .. .	28
"    "    distinct .. .. .	29
"    "    undifferentiated .. .. .	30
28. Central portion continued round outer side of processes.	
Markings obscure striæ .. .. .	<i>lucidus.</i>
"    "    extending to processes, between these its	
sides reaching close to border. Markings	
minute, punctate .. .. .	<i>sublævis.</i>
"    "    extending to processes, its sides between these	
concave outwards. Processes 4 .. .. .	<i>opulentus.</i>
29. Outline of central portion hourglass-shaped .. .. .	31
"    "    "    not hourglass-shaped .. .. .	32

31. The central portion distinct. Striæ distant, at border concave towards processes .. .. .	<i>elegans.</i>
"    "    faint opposite the central space. Striæ crowded .. .. .	<i>amænus.</i>
32. The central portion continued round outer side of processes, protruding between these opposite the central space .. .. .	<i>intercedens.</i>
"    "    reaching the processes. Markings in interrupted strands radiating from central space .. .. .	<i>subspeciosus.</i>
30. A clear curved band at sides of central space. Markings granular .. .. .	<i>Clevei.</i>
No such band .. .. .	33
33. On each side of valve 3 symmetrical lines diverging from central space towards border .. .. .	<i>lineatus.</i>
No such diverging lines .. .. .	34
34. Markings punctate, without order .. .. .	<i>nanus.</i>
"    obscure .. .. .	35
"    delicate striæ .. .. .	36
"    distinct .. .. .	37
35. A clear irregular narrow band, radiating from central space to border at sides of converging striæ. Processes 2 .. .. .	<i>barbadensis.</i>
No such band .. .. .	38
38. Apiculi few at border and midway between processes. Processes 3 .. .. .	<i>Caballi.</i>
"    on a narrow band around centre and at border. Processes 2 .. .. .	<i>punctulatus.</i>
36. Apiculi at border only, between processes. Processes 2, large prominent, chiefly at border and around central space .. .. .	<i>nebulo-punctatus.</i>
"    "    numerous, absent only from central space .. .. .	<i>normanianus.</i>
"    aggregated on a narrow band around border, about the processes, and on narrow bands at or within semi-radius, and concave outwards at the middle .. .. .	<i>punctatus.</i>
"    minute, numerous. Striæ between central space and processes straight .. .. .	<i>Stöckhardtii.</i>
"    "    at border. Rounded granules aggregated around central space .. .. .	<i>australiensis.</i>
"    most evident around border. Striæ most evident around central space .. .. .	<i>superbus.</i>
37. The strands of markings diverging from central space distant, often interrupted .. .. .	<i>formosus.</i>
"    "    irregular, broadest but unequal around central space .. .. .	<i>interruptus.</i>
"    "    interrupted to form round or irregular patches, curved, pruinose, towards the border crowded, without order .. .. .	<i>Hanckii.</i>
Striæ coarse; irregular, radial and diverging from central space, at border delicate. Apiculate .. .. .	<i>rugosus.</i>
"    forming subregular sharp rough lines, with shorter lines around border. Apiculi minute, scattered .. .. .	<i>moronensis.</i>
"    rough, more closely placed, radial and diverging. Non-apiculate .. .. .	<i>confluens.</i>
"    diverging from central space to border, straight or sigmoid, distant, convex towards the processes .. .. .	<i>pruinosus.</i>
"    course, interrupted towards central space. Processes small, high .. .. .	<i>incertus.</i>
23. Transverse areas with outer ends faint .. .. .	<i>acutiusculus.</i>
"    "    "    "    distinct .. .. .	39
39. Diverging striæ interrupted near central space, faint at border. Non-apiculate .. .. .	40
Striæ faint, continuous. Processes small, high, with free ends convex .. .. .	<i>caribæus.</i>
Markings otherwise .. .. .	<i>obscurus.</i>
41. Markings in radial strands expanding regularly to border, lines converging to processes sharply curved at inner ends, almost straight on outer portion .. .. .	41
No such strands .. .. .	<i>intermedius.</i>
	42

42. Valve elongately elliptical .. .. .	43
"   subcircular. Striæ delicate but little curved .. .. .	<i>macracamus.</i>
43. Outer ends of transverse areas close to border; striæ delicate, closely placed, convex towards processes. Apiculi few	<i>ovalis.</i>
"   "   "   "   not close to border; striæ distinct. Apiculi minute, chiefly on transverse areas and around border .. .. .	<i>prælatus.</i>
40. Processes 2, large, proximal portion obconical distal convex ..	<i>ocmaruensis.</i>
No such processes .. .. .	44
44. A second elliptical area, with major axis transverse within outer larger transverse area .. .. .	<i>lunatus.</i>
No such area present .. .. .	45
45. Transverse areas with a series of flexuous striæ around and almost parallel to their outer ends..	<i>sculptus.</i>
"   "   "   a faint reticulum at their outer ends.	<i>cælatus.</i>
"   "   "   Striæ continuous, punctate, distinct.	
"   "   "   markings in irregular plumose strands, a few irregular evident bands passing from the outer sides of these areas towards the processes .. .. .	<i>subcælatus.</i>
"   "   "   short distinct costæ at their middle, and delicate curved diverging striæ around the sides .. .. .	<i>splendidus.</i>
"   "   "   striæ fine, distant, radial; the intervals closely punctate .. .. .	<i>rhypis.</i>
Striæ throughout delicate, closely placed. Apiculi numerous, most prominent on transverse area, valve elongately elliptical .. .. .	<i>Grevillei.</i>

**PSEUDAULISCUS Sch. emend.**

*Pseudauliscus* Sch. emend., Atl. Explan., pl. xxxii. figs. 28, 29.

Valve circular, subcircular, or elliptical. Surface flat or with an elevated zone within, more rarely outside of the processes. Colour pale grey to pale smoky grey. Central space absent or minute. Markings areolate, granular or punctate in radial, rarely in secondary concentric or oblique rows, sometimes without order; striæ inconspicuous, sometimes converging around the processes or placed at a distance from these; a reticulum rare; apiculi frequent, scattered over the whole surface, or more rarely confined to the highest zone or only near the border. Border narrow, hyaline or striated. Processes 2 to 9, rarely minute, round or elliptical, inserted close to the circumference, their border sometimes striated.—Leud.-Fort. Diat. Ceyl., p. 64. *Auliscus* pro parte Jan. Abh. Schl. Ges. väter. Cult., 1861, p. 162. *Eupodiscus* pro parte Kitton in Pritch. Inf., p. 938. Grev. Trans. Mic. Soc. Lond., 1864, p. 88. *Cerataulus* pro parte Grun. in Sch. Atl., pl. cxv. fig. 10.

*Pseudauliscus ambiguus* Grev., Trans. Mic. Soc. Lond., 1863, p. 74, pl. v. fig. 23.

Roundly elliptical, major axis 0·045 to 0·055 mm., about  $1\frac{1}{3}$  times minor. Surface highest and slightly convex between the processes, thence sloping gently to the border. Colour hyaline. Markings

irregularly polygonal, about 5 to 6 in 0·01 mm., decreasing slightly towards the border. Processes 2, roundly elliptical, about 0·01 mm. broad, a limiting band of minute markings sometimes distinct.

This species forms the transition to *Eupodiscus*.

Habitat: Cambridge deposit, Barbadoes (Johnson!).

Var. *major*.—Subcircular, axes 0·05 mm., subequal. Colour pale grey. Markings 4 in 0·01 mm., outlines more distinct, largest about each side of the convex area between the processes. Border finely undulate. Processes 2, at ends of minor axis, their peripheral side more sharply defined than their central.—Pl. XV. fig. 1.

Habitat: Barbadoes (Hardman!).

*P. hirsutus* sp. n.

Elliptical, major axis 0·2 mm., about 1½ times minor. Surface rising suddenly at the processes. Colour pale grey. Markings minute polygonal areolæ, 8 in 0·01 mm., without interspaces, rows visible only around the processes, elsewhere without order; apiculi numerous, scattered but prominent. Processes 2, circular or elliptical. 0·025 mm. broad, their free ends obliquely truncated outwards, hyaline, insertion a short distance from the border.—Pl. XV. fig. 3.

Habitat: Eastern Archipelago\* (Macrae!).

*P. tetraophthalmus* Cleve MS.

Circular, diam. 0·0825 mm. Surface with 4 slight but evident cuneate inflations expanding outwards almost from the centre to the outer edge of the processes. Markings faint reticulate, about 4 in 0·01 mm., subequal, in obscure radial rows or without order, most evident on the inflations. Processes 4, symmetrical, rounded, about 0·0075 mm. broad, most abrupt on the outer side, their border narrow, smooth.—Pl. XIV. fig. 10.

The inflations here recall those found in some *Coscinodisci* and *Aulacodisci*.

Habitat: Barbadoes deposit (Cleve!).

*P. notatus*.—*A. notatus* Grev., Trans. Mic. Soc. Lond., 1865, p. 5, pl. i. fig. 2.

Circular, diam. 0·05 mm. Surface flat. Colour pale grey. Markings small, rounded, granular, irregular on the central portion, in indistinct radial but slightly curved rows towards the border, interspaces distinct, widest towards the centre. Processes 2, circular, about 0·0075 mm. broad, insertion about 1/3 of radius from the border.

Habitat: Cambridge deposit, Barbadoes (Johnson!); Oamaru deposit (Grove).

\* Found, according to Dr. Macrae, in Holothurians purchased in the China market, but probably from Torres Straits.

*P. radiatus* Bail., Smiths. Contrib., 1853, p. 6, fig. 13.

Subcircular to elliptical, major axis 0·0525 to 0·1 mm., from  $1\frac{1}{2}$  to  $1\frac{1}{10}$  times minor. Surface almost flat, rising but slightly towards the processes. Colour pale grey. Central area rounded or irregularly elliptical, with long axis at right angles to line of processes, indistinct, from 0·0075 to 0·0125 mm. broad. Markings irregular, and granular on central area, outside of this areolate, minute, gradually increasing in size towards the border; rows converging around the processes distinct, elsewhere straight or slightly convex towards the processes, and radial. Border distinct, with evident radial striæ. Processes 2, subcircular, from 0·01 to 0·015 mm. broad.—*A. Baileyi* Grev., Trans. Mic. Soc. Lond., 1863, p. 49.

The border is more evident in some smaller subcircular, than in larger elliptical specimens from Nottingham U.S.

Habitat: Nottingham deposit (Hardman!); Long Island, United States (Bailey!\*); New York Harbour (Kitton!\*); mud from New York Harbour; mud from Hudson River at West Point (Bailey, Weissflog!); Rockaway, Long Island, United States (Bailey); Pensacola (Grove!); Vera Cruz and Pensacola Bay (Deby!).

*P. Debyi* Leud.-Fort., Diat. Ceyl., p. 64, pl. viii. fig. 75.

Circular, diam. 0·125 mm. Surface sloping gently between the processes to the border. Markings rounded, granular, about 4 in 0·01 mm.; rows straight, radial, secondary indistinct concentric rows most evident towards the centre; interspaces hyaline; indistinct short radiating lines around the border, extending from about outer  $\frac{2}{5}$  of radius, striæ converging to the processes distant, short, straight or slightly curved; apiculi round, widely placed, irregular, forming a single band near the border. Processes 3, irregularly elliptical or more rounded, about 0·01 mm. broad.

Habitat: Ceylon (Leuduger-Fortmorel).

*P. peruvianus*.—*Auliscus peruvianus* Grev., Trans. Mic. Soc. Lond., 1862, p. 25, pl. ii. fig. 6.

Subcircular, elliptical or obtusely triangular, diam. 0·055 to 0·21 mm., major axis sometimes  $1\frac{2}{3}$  times minor. Surface flat at centre, sloping gently to the border, and rising gradually to the processes. Colour pale grey. Markings polygonal, 5 in 0·01 mm., irregular at the centre, elsewhere in straight radial fasciculate rows, those converging to the processes almost straight in their central, but sharply curved in their outer portion; apiculi sometimes present, but inconspicuous. Border distinct, from  $\frac{1}{20}$  to  $\frac{1}{40}$  of radius broad, striæ 10 to 12 in 0·01 mm., and at subregular intervals more evident radial lines. Processes 2, rarely 1, 3, or 4, elliptical, in small valves

\* In the Collection of Dr. R. K. Greville.

often circular.—*Auliscus radiatus* Jan. (not Ehrb.) Abh. Schl. Ges. väter. Cult., 1861, p. 162, pl. i. fig. 6. *Eupodiscus? Peruvianus* Kitton in Prich. Inf., p. 938.

This is not *Eupodiscus radiatus* W. Sm. (Syn. Brit. Diat., i. p. 24, pl. xxx. fig. 255) as Janisch has stated with some hesitation, Smith's species being a *Biddulphia* with a variety of synonyms (see p. 915). *Auliscus peruvianus* var. (?) *ovalis* Grun. forma *quadriocellata*, in Weissflog's collections, is typical.

Habitat: Peruvian guano (Kitton! Macrae! Weissflog! Greville! Rae!\*); Patos Island guano (Johnson!); Santa Marta deposit (Weissflog! Deby!); Colon, (Deby! Hardman!); Port Seguro, intestine of turtle (Hardman!†); Holothurians, California (Kinker!); loc. ? (Griffin!).

Var. *tenera* nov.—Circular, diam. from 0·05 to 0·065 mm. Surface with slope at border less evident. Markings more delicate, 8 to 10 in 0·01 mm., those around the roundly elliptical central area more prominent; the rows radial, non-fasciculate, those converging to the processes less obvious. Processes 2, round or elliptical, 0·0075 mm. broad.

Habitat: Foreign Ascidia, locality unknown (Firth!).

Var. *spinosa* Kitton MS.—Roundly elliptical, major axis 0·135 mm., about  $1\frac{1}{7}$  times minor. Surface rising somewhat steeply to the processes. Central area elliptical, distinctly defined, with major axis almost in line of processes. Markings: apiculi numerous, large, rare, on a narrow band within the border, most distinct in a circle around the border. Processes 2, relatively small, circular, 0·0075 mm. broad.

Kitton is of opinion that this var. might be united to the genus *Biddulphia*.

Habitat: Rio Janeiro (Kitton!).

*P. ralfsianus*.—*Auliscus ralfsianus* Grev., Trans. Mic. Soc. Lond., 1863, p. 52, pl. iii. fig. 21.

Roundly elliptical, major axis from 0·1125 to 0·2 mm., about  $1\frac{1}{9}$  times minor, or circular and smaller, 0·06 mm. diam. Surface highest on a median oval area extending between the processes, and about  $\frac{1}{2}$  of minor axis broad, with outer edge indistinct, sometimes on this area a depression about half of distance of process from centre, slope to the border gentle. Markings round, granular, 4 in 0·01 mm., rows straight, radial, those converging to each process manifest; a reticulum of large irregular polygonal meshes, distinct, but sometimes evanescent towards the central side of the processes, the meshes subequal or slightly smaller on the depressed portions of the median area. Border with almost regular radial sharp lines, inner edge finely and irregularly undulate. Processes 2, elliptical, large, 0·0175 to 0·025 mm. broad.—*Cerataulus pacificus* Grun., Sch. Atl., pl. cxv. fig. 10. *Eupodiscus*

\* In the Collection of Dr. Griffin.

† In the Collection of Mr. Julien Deby.

*barbadensis* Grev., *ibid.*, 1864, p. 88, pl. xii. fig 4. *Auliscus cellulatus* Grev., MS. in Coll.

Habitat : Nottingham, Maryland (Johnson! Griffin!); Cambridge deposit, Barbadoes (Johnson! Hardman!) Bridgewater deposit, Barbadoes (Johnson!); Rio Janeiro (Hardman!); Colon and Calvert County, Maryland (Kitton); Galapagos Islands (Cleve).

*P. spinosus.*—*Auliscus spinosus* F. Christian, Sch. Atl., pl. cxxv. fig. 2.

Circular, diam. 0·0925 to 0·145 mm. Surface rising gradually from the centre for about  $\frac{2}{3}$  of radius to the highest zone, the latter sharply defined on inner, less distinctly on outer side, about 0·0075 mm. broad, slope to the border gentle. Colour pale grey. Markings minute, polygonal, 10 to 12 in 0·01 mm., without interspaces, rows radial, secondary, indistinct, concentric rows visible on the highest zone, striæ converging to the processes short, distant, well marked; apiculi minute, irregularly scattered on the highest zone, a faint irregular reticulum on the outer portion of the depressed central area, and irregular short radial lines on the slope around the border. Processes 2, round, 0·0125 to 0·0175 mm. broad, close to border.—*Auliscus Febigerii* Cleve MS.

Grunow and Schmidt justly regard this species as hardly referable to *Auliscus*, but have not proposed its union to another genus.

Habitat : Nottingham deposit at West River (Febiger!\* Deby!); Cambridge deposit, Maryland (Deby!).

*P. ornatus.* *Auliscus ornatus* Grev., Trans. Mic. Soc. Lond., 1864, p. 88, pl. xii. fig. 2.

Subcircular, diam. 0·0575 mm. Surface flat. Colour pale smoky grey at centre, towards border hyaline. Markings minute, punctate, irregularly disposed, largest towards the centre, near the border faint, short faint striæ visible at the edge of the processes. Processes 5, circular, about 0·01 mm. broad, their circumference with minute irregularities.

Habitat : Cambridge deposit, Barbadoes (Johnson!); Barbadoes (Cleve!).

*P. nebulosus* Rattr. (not Leud.-Fort.).†—*Auliscus nebulosus* Grev., Trans. Mic. Soc. Lond., 1863, p. 74, pl. v. fig. 21.

Circular, diam. 0·0875 mm. Surface rising slightly to the processes. Colour pale grey to hyaline. Markings delicate striæ, those converging to the processes meeting at the centre, and at the middle of the space intervening between the processes, least distinct towards the centre; apiculi few, irregular, chiefly between the

\* In the Collection of Herr E. Weissflog.

† The name *nebulosus* has been used by Leuduger-Fortmorel for a different form, which more properly belongs to *Eupodiscus* (see p. 912).

processes and around the border. Processes 4, subcircular, about 0·0175 mm. broad, their circumference with minute irregularities, the central portion distinctly punctate.

Habitat: Cambridge deposit, Barbadoes (Johnson!); Cebu, Philippine Islands (Cleve!); Labuan (Cleve!).

*P. johnsonianus*.—*A. johnsonianus* Grev., Trans. Mic. Soc. Lond., 1863, p. 51, pl. iii. fig. 20.

Subcircular, diam. 0·0775 mm. Surface with low mammillations beneath the processes, the space between these sloping gently to the border. Colour pale smoky grey. Markings minute, punctate, irregular at the centre, about half-way between the centre and the processes in oblique irregular short lines, on the mammillations in sets of radial slightly curved striæ, and on the middle of the intervening space in radial finely flexuous rows, more faint towards the border. Processes 4, symmetrical, circular, about 0·0075 mm. broad, their border with distinct radial striæ.

Habitat: Cambridge deposit, Barbadoes (Johnson! Greville!).

Var. *eludens*.—Diam. 0·065 to 0·07 mm. Surface with diamond-shaped central area well defined, no mammillations beneath the processes. Colour almost hyaline. Markings on central area more delicate obscure puncta, striæ converging to the processes faint. Processes 4, with narrow non-striated border.

Habitat: Springfield deposit, Barbadoes (Doeg!).

*P. elaboratus*.—*Auliscus elaboratus* Ralfs, Trans. Mic. Soc. Lond., 1863, p. 51, pl. iii. fig. 19.

Circular, diam. 0·075 to 0·125 mm. Surface flat on central area, rising somewhat towards each process. Colour pale smoky grey. Central area indistinct, triangular, its sides concave between the inner ends of the curved striæ. Markings punctate on the central area, largest at its centre, delicate non-flexuous striæ curving from the outer edges of this area to the zone around the processes; this zone with its outer edge rounded, about 0·01 mm. broad, bearing delicate closely-placed irregular puncta or faint striæ, which converge around the processes, at its inner edge faint radial flexuous striæ, diverging towards the border, at the middle of the area between the adjoining processes. Processes 3, circular, about 0·015 mm. broad, the border of each faintly striated.

Habitat: Cambridge deposit, Barbadoes (Johnson!); Bridgewater deposit, Barbadoes (Johnson!); "Barbadoes" (Greville! Cleve!); Chalky Mount, Barbadoes (Firth!).

*P. trigemmis*.—*Auliscus trigemmis* Sch. Atl., pl. cxxv. fig. 16.

Circular, diam. 0·1075 mm. Surface flat, slightly convex at border. Colour pale smoky grey. Markings punctiform, scabrous, closely placed but without order. Border broad, sharply defined, hyaline. Processes 3, symmetrical, circular, about 0·025 mm. broad, their

central portion with numerous evident radial subpruinose striæ, sometimes fasciculate, and meeting at their centre or leaving an elongate narrow hyaline space, their border narrow, hyaline, their circumference smooth.

Habitat: Sysran deposit (Grove!); "Simbirsk" (Thum).

*P. pulvinatus* Cleve, Journ. Quek. Mic. Cl., 1885, p. 171, pl. xii. fig. 9.

Subcircular or circular, diam. from 0·0675 to 0·125 mm. Surface rising slightly from the centre for  $\frac{1}{4}$  to  $\frac{3}{5}$  of radius to the highest zone, this zone from  $\frac{1}{3}$  to  $\frac{1}{12}$  of radius broad, with shallow median depression. its edges indistinctly defined, sometimes passing on the outer side of the processes, slope to the border gentle. Colour pale smoky grey, darker around the edges of the highest zone. Markings minute, punctate, in indistinct irregular radial lines, those converging to the processes short, a series of faint, frequently anastomosing, hyaline lines sometimes present, most evident about the highest zone; apiculi few, near the border and about midway between the processes, sometimes absent. Processes 2 or 3, rounded, from 0·0025 to 0·0075 mm. broad, their circumference sometimes rough. —Pant. Fossil. Bacil. Ung., p. 56, pl. xix. figs. 174, 175, 177. *A. pulvinatus* var. ? Grun. in Sch. Atl., pl. cxxv. fig. 17.

In small valves the elevated zone is sometimes indistinct. Pantocsek has distinguished as forma *apiculata* and forma *inermis* specimens with and without the marginal apiculi respectively. Specimens of the latter with three processes he has named forma *inermis triocellata*.

Habitat: Kékkö deposit (Pantocsek! Kinker! Weissflog!); Szent Peter, Szakal, and Felso-Estergaly deposit (Pantocsek!); Sysran deposit (Thum!\*); Mähren deposit, Austria (Thum!\*).

*P. Petiti* Leud.-Fort. Diat. Ceyl., p. 64, pl. viii. fig. 76.

Circular, diam. 0·0875 to 0·1225 mm. Surface flat from centre to about semiradius, thence sloping gently to the border. Colour pale yellowish grey, darker about the semiradius. Markings, delicate, minute areolæ; rows straight, radial; secondary oblique decussating rows distinct; apiculi close to the border, distant, usually from 3 to 7, occurring between each process. Border opaque, sharply defined on its inner edge, narrow. Processes 3, irregularly and transversely elliptical, about 0·0075 mm. broad.—*Eupodiscus obscurus* Grev., Trans. Mic. Soc. Lond., 1862, p. 90, pl. ix. fig. 4.

Habitat: Ceylon (Leuduger-Fortmorel, Kitton! Macrae!); Cape of Good Hope (Macrae!).

*P. letonensis* Janisch, Sch. Atl., pl. lxxvii. fig. 14.

Circular, diam. 0·035 mm. Surface convex. Markings, delicate areolæ, 6 to 8 in 0·01 mm., rows straight, radial; secondary oblique decussating rows evident, striæ converging to the processes absent.

\* In the Collection of Mr. Julien Deby.

Processes 2, round, about 0·0015 mm. broad, but little elevated above the level of the adjoining surface.

Habitat: Leton Bank (Janisch).

*P. anceps* sp. n.

Subcircular, diam. 0·0825 mm. Surface subplain, rising somewhat at the processes, sometimes a clearer area, much more convex, and reaching closer to the border on one side than on the other, extending between the processes. Markings subpruinose, irregularly but inconspicuously and closely disposed radial striæ, those converging to the processes short, more distinct; apiculi numerous, minute, irregular, most crowded on the outer half of the valve, absent towards the centre. Processes 2, circular, about 0·0125 mm. broad, their border narrow, the circumference smooth.—Pl. XV. fig. 4.—*Auliscus Grovei* Cleve MS. in Coll.

Habitat: Oamaru deposit (Grove! Cleve!).

*P. diffusus* sp. n. Sch. Atl., pl. cxxv. fig. 10 (without name).

Circular, diam. from 0·075 to 0·1125 mm. Surface subplain, processes low. Colour pale smoky grey. Markings minute, punctate, closely disposed, irregular or in faint radial or oblique rows; apiculi numerous, most crowded towards the border, absent from a central circular area, about 0·0175 mm. broad. Processes 2, oval, with the narrower end directed towards the centre, sometimes more nearly circular, about 0·02 mm. broad, their border with distinct radial punctate striæ, their circumference rough.—*Auliscus punctatus* var.? or n. sp.? Cleve MS. in Coll.

I have not observed the small central space shown in Schmidt's figure.

Habitat: Oamaru deposit (Grove! Hardman! Cleve!).

*P. rotatus* sp. n.

Circular, diam. 0·075 mm. Surface subplain, the central area clear, pentagonal, with sides deeply concave outwards, and angles obtuse, extending outwards to processes. Colour pale grey. Markings minute, punctate, obscure, least evident on the central area, without order, striæ converging to processes absent, non-apiculate. Processes 5, symmetrical, circular, 0·01 mm. broad, their border narrow.—Pl. XVI. fig. 7.

Habitat: Chalky Mount, Barbadoes (Firth!).

ARTIFICIAL KEY.

1. Processes 3, large, circular, their central portion with evident radial striæ extending to their border .. .. . *trigemmis*  
 No such processes .. .. . 2
2. Highest zone distinct, sharply defined on inner side and apiculate; markings minute, granular, in secondary concentric rows on the highest zone .. .. . *spinus*

Highest zone indistinctly defined; markings punctate in radial rows only .. .. .	<i>pulvinatus</i>
No such zone .. .. .	3
3. Border sharply defined .. .. .	4
"   inconspicuous .. .. .	5
4. Markings minute, areolate, in radial and oblique rows; apiculi 3 to 7 between adjoining processes, prominent ..	<i>Petiti</i>
"   granular, increasing towards the border, non-fasciculate. Border striated .. .. .	<i>radiatus</i>
"   areolate, rows fasciculate, the converging rows sharply curved near the processes .. .. .	<i>peruvianus</i>
5. Surface convex. Processes minute. Markings delicate, areolate, in radial and oblique decussating rows. Processes 2 ..	<i>letonensis</i>
"   almost flat. Processes large .. .. .	6
"   with a truncate inflation tapering inwards from each of the 4 processes. Markings areolate, 4 in 0·01 mm., most evident on the inflations .. .. .	<i>tetraophthalmus</i>
6. Markings areolate, 4 in 0·01, non-apiculate .. .. .	<i>ambigus</i>
"   "   8 in 0·01 mm., rows visible only at processes, apiculi prominent .. .. .	<i>hirsutus</i>
"   granular .. .. .	7
"   more minute, punctate, or forming delicate striæ ..	8
7. Rows radial, striæ converging to processes short, a circlet of distinct apiculi at border; no reticulum .. ..	<i>Debyi</i>
"   "   a large meshed reticulum .. .. .	<i>rufsiianus</i>
"   short, radial, indistinct near border, elsewhere markings irregular .. .. .	<i>notatus</i>
8. A zone round each process punctate, outside of this zone short curved striæ, centre punctate .. .. .	<i>elaboratus</i>
No such zone .. .. .	9
9. Markings punctate, irregular at centre, in faint oblique lines near processes; low mammillations beneath the processes. Processes 4 .. .. .	<i>johnsonianus</i>
"   striate in subregular order. Valve apiculate .. ..	10
"   punctate, without order. Valve non-apiculate .. ..	11
10. Apiculi evident, absent from a small central area. Processes 2. Markings in radial rows .. .. .	<i>diffusus</i>
"   minute, but numerous. Markings subpruinose in conspicuous close radial striæ, those converging to the processes short, more evident .. .. .	<i>anceps</i>
"   faint, chiefly near border. The four sets of converging striæ meeting at centre and at middle of space between adjoining processes .. .. .	<i>nebulosus</i>
11. Markings largest at centre. Processes 5 .. .. .	<i>ornatus</i>
A pentagonal clear central area with sides concave and angles reaching the processes .. .. .	<i>rotatus</i>

#### MONOPSIA Grove & Sturt.

*Monopsia* Grove & Sturt, Journ. Quek. Mic. Cl., 1887, p. 141.

Valves circular. Surface rising gradually towards the process. Colour pale yellowish grey. Central space absent. Markings, delicate closely-placed striæ radiating from the edge of the process to the border, but less evident on a narrow distinct band contiguous to the border, minute scattered apiculi irregularly disposed, or most abundant near the inner edge of the marginal band. Process single, eccentric, circular, with a single band of distinct elliptical granules, having the long axes radial about its semiradius, the outer portion finely striated, the free end almost flat.

*M. mammosa* Grove & Sturt, Journ. Quek. Mic. Cl., 1887, p. 142, pl. xiii. fig. 38.

Diam. from 0·07 to 0·1325 mm. Colour sometimes pink near the process. Markings striate, striæ 8 in 0·01 mm., sometimes scabrous, the marginal band about 0·01 mm. broad, its inner edge irregular. Process from 0·0125 to 0·0275 mm. broad.—Sch. Atl., pl. cxxv. figs. 14, 15.

Habitat: Oamaru deposit (Grove! Rae! &c.).

#### DEBYA gen. n.

Valves circular. Surface flat on central portion, slope to border distinct. Colour pale smoky grey. Markings minute, punctate, in radial lines, a reticulum sometimes present. Processes minute, 3 to 15, rounded or elliptical, between each adjoining pair 1 or 2 small apiculi.—*Glyphodiscus* pro parte Grove & Sturt, Journ. Quek. Mic. Cl., 1887, p. 10. Grun. in Sch. Atl., pl. cxxv. *Eupodiscus* pro parte Grun., Bot. Centralbl., Bd. xxxi. No. 5, 1887, p. 133. Sch. Atl., pl. lxxx.

*D. oamaruensis*.—*Eupodiscus oamaruensis* Grun., Bot. Centralbl., Bd. xxxi. No. 5, 1887, p. 133.

Diam. 0·06 to 0·095 mm. Surface almost flat from centre for about 5/18 of radius, slope to border steep. Colour most opaque around the flat central portion. Markings in faint radial lines; a reticulum sometimes distinct, with meshes  $3\frac{1}{2}$  to 4 in 0·01 mm., diminishing somewhat towards the border. Processes distinct, 0·0035 mm. broad. Height of centre above edge of girdle 0·025 mm.—*Glyphodiscus scintillans* Grove & Sturt, Journ. Quek. Mic. Cl., 1887, p. 10. *Eupodiscus simbirskianus* Grun., Bot. Centralbl., Bd. xxxi. No. 5, 1887, p. 133. Sch. Atl., pl. lxxx. fig. 8. *Glyphodiscus*(?) *simbirskianus* Grun. in Sch. Atl., pl. cxxv. figs. 18 a-c, 19. *G.*(?) *oamaruensis* Grun. in Sch. Atl., pl. cxxv. fig. 20.

Habitat: Sysran deposit, Simbirsk (Deby!); Oamaru deposit (Grove! Hardman!).

#### EUPODISCUS Ehrb. emend.

EUPODISCUS Ehrb. emend., Mon. Ber. Ak, 1844, p. 73.

Circular. Surface flat or slightly convex, the centre sometimes slightly depressed. Colour pale to dark grey. Central space and rosette absent. Markings areolate, subequal or decreasing from the centre outwards, rarely smallest at the centre; rows radial, straight or curved, sometimes fasciculate or subradial, concentric, or without order; oblique decussating rows sometimes manifest, a distinct band surrounding each process rare; apiculi few or more numerous, and forming a circlet close to the border. Border narrow and hyaline, or with delicate striæ, and sometimes broad and more prominent, with

evident striæ. Processes 1 to 4, circular or roundly elliptical, with major axis radial or at right angles to the radius, sometimes small, inserted close to or a short distance within the border.—*Aulacodiscus* Brightw. pro parte, Quart. Journ. Mic. Sci., 1860, p. 95.

### § 1. HUMILES.

Markings in radial, sometimes concentric or oblique rows or without order. Border simple.

*E. trioculatus* Grev., Trans. Mic. Soc. Lond., 1864, p. 88, pl. xii. fig. 3; Van Heurck, Syn. Diat. Belg., pl. cxviii. fig. 8.

Diam. from 0·0525 to 0·0825 mm. Surface almost flat. Colour pale grey. Markings delicate unequal areolæ, about  $2\frac{1}{2}$  to 3 in 0·01 mm., disposed without order, an indistinct band surrounding each process. Border indistinct. Processes 3, circular, about 0·01 mm. broad, insertion near border.

Habitat: Cambridge deposit, Barbadoes (Johnson! \*).

*E. oculatus* Grev., Trans. Mic. Soc. Lond., 1862, p. 90, pl. ix. fig. 3.

Diam. from 0·05 to 0·15 mm. Surface flat or slightly depressed at centre, with the highest zone indistinctly defined, extending between the processes and sloping gently outwards to border. Colour dark grey. Markings irregular polygonal areolæ, about  $3\frac{1}{2}$  to 4 in 0·01 mm., largest at the centre, decreasing gradually towards the border, somewhat pearly, strongly marked, disposed without order within zone of processes, and in faint, oblique, curved, decussating rows near the border; short delicate radial striæ, 8 to 10 in 0·01 mm. around inner edge of border. Border distinct, from  $\frac{1}{10}$  to  $\frac{1}{15}$  of radius broad, its inner wider portion hyaline, the outer with a single band of closely disposed granules. Processes 2, subcircular or radially elliptical, from 0·01 to 0·015 mm. broad, insertion about  $\frac{2}{3}$  of radius from centre.

Habitat: Monterey Stone (Johnson! Kitton! Griffin!); Santa Monica deposit (Kitton! Ææ! † Griffin!); "Monterey" (Hardman!); Los Angeles (Hardman!).

*E. simplex* Grev., Trans. Mic. Soc. Lond., 1863, p. 73, pl. iv. fig. 20.

Diam. from 0·075 to 0·17 mm. Surface flat. Markings subequal, hexagonal areolæ 4 in 0·01 mm., without a central dot, disposed in straight or slightly curved oblique decussating rows, no distinct band around processes or border; apiculi numerous, prominent, somewhat irregular, forming a single band close to the border. Border narrow, hyaline. Processes 2, subcircular or roundly oval with long axis subradial, from 0·0125 to 0·0175 mm. broad.

Habitat: Cambridge deposit, Barbadoes (Johnson!); "Barbadoes" (Greville!).

\* In the Collection of Dr. Greville.

† In the Collection of Dr. John Murray, Edinburgh.

*E. inconspicuus* sp. n.

Diam. 0·055 mm. Surface flat. Colour pale grey. Markings hexagonal areolæ, 4 in 0·01 mm., subequal or somewhat smaller around the border, without order. Border narrow, hyaline. Processes 4, symmetrical, minute; subcircular, about 0·0025 mm. broad, placed upon the outermost band of areolæ.

This species has sometimes been united to *E. radiatus* to which it shows no close affinity.

Habitat: Cove, Calvert County, Maryland (Greville!).

*E. minutus* Grev., Trans. Mic. Soc. Lond., 1866, p. 5, pl. i. fig. 13.

Diam. 0·05 mm. Surface slightly convex. Markings obscure, areolate, 5 in 0·01 mm., subequal to border, without order. Border narrow, hyaline. Processes 4, about  $\frac{1}{4}$  of radius from circumference, circular,\* 0·005 mm. broad, provided with a prominent lip on their peripheral side.

Greville expresses doubt as to the position of this species, and notes that the processes are somewhat similar to those of *Graspedoporus*. The structure is, however, quite eupodiscoid.

Habitat: Springfield deposit, Barbadoes (Hardman †).

*E. californicus* Grun., Van Heurck, Syn. Diat. Belg., pl. cxviii. fig. 8.

Diam. 0·0475 to 0·075 mm. Surface almost flat. Colour pale grey. Markings, delicate polygonal areolæ without a distinct rounded central granule, irregular but largest about the centre, and decreasing gradually towards the border, 6 to 8 in 0·01 mm., arranged to form an evident band round each process, elsewhere in straight, radial, non-fasciculate rows; apiculi 3, distinct, equidistant from the processes, but closer to the border, sometimes a few other smaller apiculi also near the border. Border distinct, about  $\frac{1}{10}$  to  $\frac{1}{14}$  of radius broad, striæ at its inner edge delicate, 8 in 0·01 mm., those on the outer edge shorter, about 6 in 0·01 mm., intermediate portion hyaline. Processes 3, circular, about 0·003 mm. broad, insertion from  $\frac{3}{4}$  to  $\frac{4}{5}$  of radius from border.

Habitat: Gulf of California (Hardman! Van Heurck); "California" (Cole †‡).

*E. decrescens* sp. n.

Diam. 0·04 to 0·0625 mm. Surface slightly convex. Colour pale to dark grey. Markings hexagonal, areolæ largest at centre and decreasing uniformly towards the border, from 3 to 6 in 0·01 mm., forming oblique, slightly curved, decussating, non-fasciculate rows;

\* In the figure the processes are shown as transversely elliptical.

† I am informed by Mr. Hardman that the original of the species is lost, the slide on which it was mounted having been broken in the Post Office.

‡ In the Collection of Mr. F. Kitton.

a distinct apiculus close to border on each side of the valve and equidistant from the processes. Border hyaline, narrow. Processes 2, close to the border, about 0·003 mm. broad, but high, with truncated ends, and directed obliquely outwards.—Pl. XIV. fig. 9.

Habitat: Kannahack, Cannibal Islands (Greville!).

*E. nebulosus*.—*P. nebulosus* Leud-Fort., Diat. Ceyl., 1879, p. 64, pl. vii. fig. 74.

Diam. 0·12 mm. Surface slightly convex towards the border. Markings minute, areolate, (8?) in 0·01 mm., radial rows obscure, the oblique decussating rows straight, evident; apiculi many, prominent, forming a distinct circlet close to the border, inserted at subregular intervals. Processes 3, symmetrical, elliptical, with major axis at right angles to corresponding radius, low.

The appearance of the markings and processes seems to me to ally this valve to *Eupodiscus* rather than to *Pseudauliscus*.

Habitat: Ceylon (Leuduger-Fortmorel).

*E. parvulus* Grev. MS. in Herb. Brit. Mus.

Diam. 0·0525 to 0·0875 mm. Surface with central portion flat, the slope to the border gentle. Colour pale grey to subhyaline. Markings areolate, towards the centre 5 to 6, decreasing gradually towards the border to 8, in 0·01 mm., without order at the centre, elsewhere in uniformly curved, radial, subfasciculate, decussating rows. Border narrow, hyaline, or with faint striæ, 8 in 0·01 mm. Processes 1 or 2, subcircular or subregularly elliptical, 0·0025 to 0·003 mm. broad, placed close to the border, sometimes more prominent on the peripheral side.—Pl. XIV. fig. 8.

Some specimens labelled *E. punctulatus* by Greville agree with several others which he named *E. parvulus*.

Habitat: "Barbadoes" (Johnson! Greville!); Cambridge deposit, Barbadoes (Johnson!).

Var. *concentrica*.—Diam. (?). Markings subequal from the centre to about semiradius, beyond this decreasing somewhat rapidly outwards, becoming punctiform near the border; on the central portion irregular, beyond this in evident concentric regular bands. Processes 2, prominent, but small.—Pl. XIV. fig. 7.

This var. is established on an unpublished drawing by Greville, now in the British Museum. It is distinguished from *E. punctulatus* by the concentric arrangement of the markings beyond the semiradius. I have found no specimens in Greville's collection corresponding to the drawing, which he left unnamed.

Habitat: Loc. ? (Greville).

*E. punctulatus* Grev., Trans. Mic. Soc. Lond., 1863, p. 73, pl. v. fig. 19.

Diam. 0·08 mm. Surface slightly convex. Colour pale grey. Markings punctate, smallest at the centre, soon becoming somewhat

larger and subequal to the border; irregular at the centre, beyond this in evident, regular, concentric bands. Border narrow, hyaline. Processes 4, roundly elliptical, placed close to the border, about 0·0075 mm. broad.

Habitat: Cambridge deposit, Barbadoes (Johnson).

## § 2. NOBILES.

Markings fasciculate, evident. Border prominent.

*E. radiatus*\* Bail. Smiths. Contrib., 1851, Art. 8, p. 39.

Diam. from 0·045 to 0·1175 mm. Surface flat, slope at border gentle. Markings hexagonal areolæ, 4 in 0·01 mm., subequal, in subradial, almost straight rows arranged in fasciculi, a single distinct band of smaller areolæ around the processes, and of larger somewhat unequal ones around the border. Border narrow, striæ delicate, 14 to 16 in 0·01 mm. Processes 4, central portion hyaline, rounded, about 0·0075 mm. broad.—*Aulacodiscus radiatus* Brightw., Quart. Journ. Mic. Sci., 1860, p. 95, pl. v. figs. 10a, 10b (not *Aulacodiscus radiatus* Grev., Trans. Mic. Soc. Lond., 1864, p. 11, pl. i. fig. 4); Ralfs in Pritch. Inf., p. 843; H. L. Smith, Diat. Spec. Typ., No. 164; Van Heurck, Typ. Syn. Diat. Belg., No. 509.

Ralfs states that the processes may be more than 4, as formerly doubtfully asserted by Bailey. I have only seen specimens with 4.

Habitat: Soundings, South Atlantic, 2835 fathoms (H. L. Smith!); South America (Van Heurck!); rice-fields, Georgia (Norman!); sand from Kamortha, Nicobar Islands (Frauenfeld); shell cleanings (Doeg! †); Colon (Hardman!).

Var. *humilis*.—Diam. 0·045 mm. Surface slightly convex between the processes. Markings sometimes forming fasciculi only between the centre and the processes, the rows in the fasciculi converging to the processes, elsewhere the secondary oblique rows more evident; no distinct band around the processes or border; apiculi 2, inserted near the border, long, narrow, and equidistant, on opposite sides of the valve from the processes. Processes 2, conical, with obtuse free ends.

Habitat: River Orwell (W. Smith!); Medway (Dallas!).

*E. hardmanianus* Grev., Trans. Mic. Soc. Lond., 1866, p. 80,  
pl. viii. fig. 14.

Circular, rarely irregularly oval, diam. from 0·0925 to 0·16 mm. Surface flat or slightly convex at the centre, the outer half flat. Colour pale grey. Markings hexagonal areolæ, subequal, 4 in 0·01 mm., irregular, on a small central area outside of this in straight or substraight, subradial, fasciculate rows. Border broad, somewhat elevated, its inner edge irregular, with remote, irregular, coarse radial striæ and delicate intervening striæ, 8 in 0·01 mm. Processes 4,

\* Not *E. radiatus* W. Sm., see p. 915.

† In the Collection of Dr. Griffin.

rarely unsymmetrical, inserted close to border, circular, or transversely elliptical, hyaline, about 0·005 mm. broad.

This species, founded on Hardman's South American valves, is not to be separated from the specimens in the collections of Greville and Hardman labelled *E. marginatus*.

Habitat: Bridgewater deposit, Barbadoes (Johnson!); Cambridge deposit, Barbadoes (Johnson! Greville!); Colon (Hardman! Kitton!); shell cleanings, South America (Hardman); Gulf of California (Hardman!),

SPECIES EXCLUSÆ VEL INQUIRENDÆ.

*E. americanus* Ehrb. (fide Ralfs in Pritch. Inf., p. 843). *E. germanicus* Ehrb. (Mon. Ber. Ak., 1844, p. 81). *E. quaternarius* Ehrb. (ibid. 1844, p. 81). *E. quinarius* Ehrb. (ibid. 1844, p. 81). *E. monstruosus* Ehrb. (ibid. 1884, p. 81), and *E. argus* W. Sm. (Syn. Brit. Diat., i. p. 24) are *Aulacodiscus argus* (Ratray, Journ. Roy. Mic. Soc. Lond., 1888, pp. 373, 374).

*E. Rogersii* Ehrb. (Mon. Ber. Ak., 1844, p. 81), and *E. Baileyi* Ehrb. (ibid.) are *Aulacodiscus Rogersii* Sch. (Ratray ibid.),

*E. crux* Kütz. (Sp. Alg., p. 135) is *Aulacodiscus crux* Ehrb. (Mon. Ber. Ak., 1844, p. 76).

*E. ? tripes* Johnson (Amer. Journ. Sci., vol. xiii., 1852, p. 33) is said to resemble *Coccolithus radiatus*, but it possesses 3 processes similar to those of *Eupodiscus*. Specimens so named have been procured from Chinchu guano near the Pacific Coast.

*E. crassus* W. Sm. (Syn. Brit. Diat., i. p. 24, pl. iv. fig. 41) is identical with *Actinocyclus octonarius* Ehrb. (Mon. Ber. Ak., 1837, p. 61) which is one of the forms of *A. Ehrenbergii* Ralfs (Pritch. Inf., p. 834).

*E. fulvus* W. Sm. (Syn. Brit. Diat., i. p. 24, pl. iv. fig. 40), belongs to *Actinocyclus* (see p. 897).

*E. sculptus* W. Sm. (Syn. Brit. Diat., i. p. 25, pl. iv. fig. 42) is *Auliscus sculptus* Ralfs (see p. 884).

*E. tenellus* de Bréb. (Mém. Soc. Imp. d. Sci. Nat. Cherb., 1854, p. 257, fig. 9) belongs to *Actinocyclus*. The pseudonodule near the border is evident, and the structure otherwise is actinocycloid. De Brébisson united the specimen with some doubt to *Eupodiscus*, and Donkin, though endorsing the same doubt, did not remove it from *Eupodiscus* (Quart. Journ. Mic. Sci., 1861, p. 7).

*E. crucifer* Shalb. (Trans. Mic. Soc. Lond., 1854, p. 16, pl. i. fig. 12) and *E. Petersii* Kütz. (Sp. Alg., p. 135) are *Aulacodiscus Petersii* (Ratray. ibid., 1888, p. 366).

*E. Ralfsii* W. Sm.\* (Syn. Brit. Diat., ii. p. 86) is *Actinocyclus Ralfsii* (Ralfs in Pritch. Inf., p. 835). *E. sparsus* Greg. (Trans. Mic.

\* Prof. W. Smith was induced to separate his *Eupodiscus Ralfsii*, *E. fulvus*, and *E. crassus* from *Actinocyclus* as he limited the latter genus to frustules possessing undulate valves. He however recognized the presence of the pseudonodule which is a structural feature more significant than mere form of surface, and also a better guide to natural relationship.

Soc. Lond., 1857, p. 81, pl. i. fig. 47) is *Actinocyclus Ralfsii*  $\beta$  *sparsus* Greg. (Ralfs in Pritch. Inf., p. 855).

*E. tessellatus* Roper (Quart. Journ. Mic. Sci., 1858, p. 19, pl. iii. figs. 1a, b) is *Roperia tessellata* Grun. (see p. 917).

*E.?* *Grevillei* Ralfs (Pritch. Inf., p. 938). Ralfs only supplies the following characters: Markings obscure, punctate, spines arranged in a circlet between the processes and the centre, systephanioid. Primary rays absent. Processes 3, clavate, aulacodiscoid.—Habitat: Monterey. This unfigured species probably belonged to *Aulacodiscus*.

*E. ovalis* Norman (Trans. Mic. Soc. Lond., 1861, p. 8, pl. ii. fig. 6) is *Actinocyclus ovalis* (Van Heurck, Syn. Diat. Belg., pl. cxxiv. fig. 11).

*E.?* *peruvianus* Kitton (Pritch. Inf., p. 938) is *Pseudauliscus peruvianus*, (see p. 903).

*E. obscurus* Grev. (Trans. Mic. Soc. Lond., 1862, p. 90, pl. ix. fig. 4), is *Pseudauliscus Petiti* (see p. 906).

*E. minutus* Hantzsch (Raben. Beitr., Heft i., 1863, p. 21, pl. vi. fig. 9) is an *Actinocyclus*.

*E. barbadensis* Grev. (Trans. Mic. Soc. Lond., 1864, p. 88, pl. xii. fig. 4) is *Pseudauliscus ralfsianus* (see p. 904).

*E. scaber* Grev. (Trans. Mic. Soc. Lond., 1864, p. 81, pl. x. fig. 1) is a *Cerataulus*.

*E. eccentricus* O'Me. (Quart. Journ. Mic. Sci., 1867, p. 245, pl. vii. fig. 2) is *Coscinodiscus eccentricus* var. *hyalina*, not *Coscinodiscus minor* as stated in the second edition of Habirshaw's Cat. Diat. § *Eupodiscus*.

*E. gregorianus* Breb. (Journ. Quek. Mic. Cl., 1870, p. 41) is synonymous with *E. subtilis* Greg. (Trans. Roy. Soc. Edin., 1857, p. 501, pl. xi. fig. 50; Raben. Alg. Europ., No. 2001), and belongs to *Actinocyclus*. *E.?* *subtilis* Ehrb. (Mon. Ber. Ak., 1855, p. 302) is a *nomen nudum*. Specimens so designated were procured from Simbirsk.

*E. Roperii* de Bréb. (Journ. Quek. Mic. Cl., 1870, p. 41; Raben. Alg. Europ., No. 2005) is identical with *Coscinodiscus ovalis* Roper (Trans. Mic. Soc. Lond., 1858, p. 21, pl. iii. fig. 4), with *Actinocyclus ovalis* Grun., and *A. Roperii* (Van Heurck, Syn. Diat. Belg., pl. cxxv. fig. 5).

*E. velatus* Grev. (Möll. Cat., 1874).—The specimen in Mr. Julien Deby's Typenplatte No. 380, 4-3-12, by Möller, is *E. radiatus* W. Sm. (Syn. Brit. Diat., i. p. 24, pl. xxx. fig. 255), and is synonymous with *Biddulphia radiata* W. Sm.—not Roper or Brightw.—(ibid., ii. p. 48, pl. lxii. fig. 255), *B. hemitropa* L. W. Bail. (Boston Journ. Nat. Hist., 1862, p. 344, pl. viii. figs. 71-73, *Zygoceeros hemitropus* Bail. (ibid.), *Cerataulus Smithii* Ralfs (Pritch. Inf., p. 847), and *Odontella Smithii* Van Heurck (Syn. Diat. Belg., pl. cv. figs. 1, 2.), but not with *Auliscus radiatus* Janisch (Abh. Schl. Ges. väter. Cult., 1861, p. 162, pl. i. fig. 6; Raben. Beitr., 1863, p. 4, pl. iii. fig. 15) as stated in 2nd edition of Habirshaw's Cat. Diat. § *Auliscus*.

*E. interpunctatus* Brightw.—This species is only mentioned by Grunow (SB. naturw. Ges. Isis Dresden, 1878, p. 131) in his

remarks on *Hyalodiscus maximus* (*Cyclotella maxima* Kütz.). According to Prof. H. L. Smith, who possesses original specimens, it is identical with the latter, an opinion which Grunow is unable to adopt.

*E. commutatus* Grev. (Möll. Cat., 1883, fide Habirsh. Cat. Diat. § *Eupodiscus*) has been named by some *Coscinodiscus concinnus* var. *commutata*; it may be united with the older *E. jonesianus* (Grev. Trans. Mic. Soc. Lond., 1862, p. 22, pl. ii. fig. 3) which is a var. of *Coscinodiscus concinnus*.

*E. Weissflogii* Grun. (Typ. Syn. Diat. Belg., No. 11) has been justly associated to *Eupodiscus* with hesitation by Van Heurek who, in the explanation of his slide, has provisionally united it to *Micropodiscus* Grun. To this genus, modified from its original conception, it may be united.

*E. punctatus* Bail. is an MS. name found in Bailey's collection, but remains a *nomen nudum* (Habirsh. Cat. Diat., 2nd ed., § *Eupodiscus*).

*E. Debi* Grove & Sturt (Grun. in Bot. Centralbl., Bd. xxxiv. Nos. 15-16, p. 38) is *Lampriscus* (?) *Debi* Grove & Sturt (Journ. Quek. Mic. Cl., 1887, p. 138, pl. xi. fig. 27). To neither of these genera is this valve readily assignable, and I regard it as the type of a new genus *Isodiscus*.

The transition to *Biddulphia* from *Eupodiscus* is found in the Oamaru *Biddulphia lata* Grove & Sturt (Journ. Quek. Mic. Cl., 1887, p. 135, pl. xiv. fig. 53).

## ARTIFICIAL KEY.

1. Markings delicate .. .. .	2
"   well defined and more evident .. .. .	3
2. Processes 4. Markings punctate, irregular at centre, elsewhere in concentric bands .. .. .	<i>punctulatus.</i>
Markings not in concentric bands .. .. .	4
4. Processes 1 or 2. Markings 5 to 6, decreasing gradually outwards to 8 in 0·01 mm.; rows curved, subfasciculate .. .. .	<i>parrulus.</i>
"   3, circular. Markings unequal, 2½ to 3 in 0·01 mm., without order, an indistinct band round each process .. .. .	<i>trioculatus.</i>
"   4, inserted at one-fourth of radius from circumference, prominent on their outer edge. Markings 5 in 0·01 mm., subequal, without order .. .. .	<i>minutus.</i>
3. Apiculate .. .. .	5
Non-apiculate .. .. .	6
5. Apiculi 3, equidistant from the 3 processes. Markings 6 to 8 in 0·01 mm., rows radial, a distinct band round each process .. .. .	<i>californicus.</i>
"   2, equidistant from the 2 processes. Markings largest at centre, decreasing rapidly outwards from 3 to 6 in 0·01 mm., rows oblique, curved, decussating .. .. .	<i>decreescens.</i>
"   numerous, forming a distinct circle close to border. Markings subequal, 4 in 0·01 mm. Processes 2, large, oval, with long axis radial .. .. .	<i>simplex.</i>
"   evident, forming a circle close to border. Markings equal, in straight, oblique, decussating rows. Processes 3, elliptical, with major axis at right angles to radius .. .. .	<i>nebulosus.</i>

- |  |                      |
|--|----------------------|
| 6. Border narrow, hyaline or with faint striæ .. .. .  | 7                    |
| "   broader, more prominent, striæ distinct .. .. .  | 8                    |
| 7. Processes 4, subcircular, small. Markings 4 in 0·01 mm., subequal, without order .. .. .  | <i>inconspicuus.</i> |
| "   4, larger. Markings hexagonal, 4 in 0·01 mm.; rows fasciculate, subradial: a single distinct band of smaller areolæ around the processes, and of larger unequal ones around the border .. .. .       | <i>radiatus.</i>     |
| 8. Processes 2, large. Markings 3½ to 4 in 0·01 mm., without order within the processes, in faint, oblique, curved, decussating rows near border. Border with inner part hyaline, outer granular .. .. . | <i>oculatus.</i>     |
| "   4. Markings subequal, 4; rows fasciculate, subradial. Border with remote, coarse, and delicate intervening striæ .. .. .   | <i>hardmanianus.</i> |

**ROPERIA** Grun.

*Roperia* Grun., Van Heurck Syn. Diat. Belg. Explan., pl. cxviii. fig. 6.

Circular or subcircular. Surface flat at centre, sloping gently near border. Colour pale grey. Markings hexagonal, areolate, in almost straight decussating rows at centre, subfasciculate towards the border. A single small circular hyaline spot close to the border.—*Eupodiscus* pro parte Roper, Quart. Journ. Mic. Sci., 1858, p. 19. *Actinocyclus* pro parte Ralfs in Pritch. Inf., p. 835.

*R. tessellata* Grun., Van Heurck Syn. Diat. Belg., pl. cxviii. figs. 6, 7.

Diam. from 0·0575 to 0·07 mm. Surface with slope around border extending inwards for 1/8 to 1/10 of radius. Markings 6 in 0·01 mm., decreasing towards the border, the hyaline spot close to the border from 0·0025 to 0·003 mm. broad.—*Eupodiscus tessellatus* Roper, Quart. Journ. Mic. Sci., 1858, p. 19, pl. iii. figs. 1a, 1b. *Actinocyclus tessellatus* Ralfs in Pritch. Inf., p. 835.

This is not *Coscinodiscus limbatus* Ehrb. (Mikrog., pl. xx. fig. 29) nor *Coscinodiscus fimbriatus* Ehrb. (Mikrog., pl. xxii. fig. 2) as stated by Roper.

Habitat: Caldy, Pembrokeshire (Roper!); Ascidians, Hull (Grevory! Greville!); off Cape Finisterre, in 2360 fathoms (Greville!); stomach of *Pecten* (Grove!); 'Gazelle' Expedition (Weissflog!).

**FENESTRELLA** Grev.

*Fenestrella* Grev., Trans. Mic. Soc. Lond., 1863, p. 67.

Frustules free, disciform. Surface slightly convex; a small, semi-circular, hyaline area, convex towards the border, on opposite sides of, and at equal distances from, the central space, at about 3/5 of radius from centre. Colour pale grey. Central space narrow, bent, but elongate between the inner ends of the converging rows of areolæ. Markings hexagonal, areolate, minute around border, in evident rows converging from central space to the semicircular hyaline areas, elsewhere in fasciculate or radial, less conspicuous rows.

*F. barbadosis* Grev., Trans. Mic. Soc. Lond., 1863, p. 68, pl. iv. fig. 8.

Diam. 0·0875 mm. The semicircular hyaline areas about 0·005 mm. broad. Colour darker towards the centre. Central space 0·0125 mm. long. Markings in the converging rows subequal, 4 in 0·01 mm., elsewhere decreasing gradually for about  $\frac{3}{5}$  of radius, and then more suddenly to the border. Border narrow, with minute, irregularly placed, distant apiculi.

Habitat: Cambridge deposit, Barbadoes (Johnson!).

#### CRASPEDOPORUS Grev.

*Craspedoporus* Grev. emend., Trans. Mic. Soc. Lond., 1863, p. 68.

Valves circular, sometimes dissimilar. Surface usually with distinct compartments, subplain or the compartments sometimes rising towards the border. Colour pale grey. Central space distinct, rounded, sometimes small or absent. Markings punctate, areolate or granular, without order or in radial or oblique rows, secondary sub-concentric rows rarely visible, sometimes converging around processes. Border with delicate striæ or hyaline. Processes 5 to 11, placed on the alternate compartments, subcircular, or roundly elliptical, with major axis radial or at right angles to the radius, sometimes with the outer edge elevated and pocket-like, a surrounding hyaline space sometimes present.

In its general characters this genus hardly approaches *Coscinodiscus* as stated by Greville. It is much nearer the *Eupodiscæe* in the character of the processes, but is quite distinct in other respects. Some frustules with dissimilar valves have one of the valves approaching *Porodiscus*.

*C. ralfsianus* Grev., Trans. Mic. Soc. Lond., 1863, p. 68, pl. iv. fig. 9.

Diam. 0·105 mm. Surface with distinct compartments, those bearing the processes expanding outwards at first regularly, then more suddenly near the processes, the others wider. Central area circular, about  $\frac{1}{4}$  of diam. broad, somewhat more dense than outer portion. Markings irregularly areolate, the meshes smallest about outer edge of central area, about 4 in 0·01 mm. Processes 8 to 9, subcircular, with major axis radial, their distal edge sometimes elevated, giving a pocket-like appearance.

Habitat: Cambridge deposit, Barbadoes (Ralfs, Johnson).

*C. johnsonianus* Grev., Trans. Mic. Soc. Lond., 1863, p. 69, pl. iv. fig. 10.

Diam. 0·625 to 0·07 mm. Surface compartments with straight edges, those bearing the processes rising gradually outwards, the others flat. Central space pentagonal, hyaline, about  $\frac{1}{5}$  of diam.

broad. Markings minute, punctate, in faint lines passing obliquely inwards from the centre of the compartments bearing the processes, and converging around the latter, on the intervening compartments without order. Processes 5, elliptical, with major axis at right angles to corresponding radius, about 0·01 mm. long, their border broad, striated. Border narrow, hyaline.

Habitat: Cambridge deposit, Barbadoes (Johnson!).

*C. elegans* Grove & Sturt, Journ. Quek. Mic. Cl., 1887, p. 64, pl. v. fig. 6.

Diam. 0·0625 to 0·0825 mm.. Valves dissimilar, the one with surface subplain or slightly convex from centre to zone of processes, between the latter sloping gently to border. Central space angular to round, from 1/12 to 1/16 of diam. broad. Markings round, granular, towards the centre 6 to 7, near the border 8 in 0·01 mm.; rows uninterrupted, radial, straight, inconspicuous within the processes, secondary irregularly subconcentric rows most evident, on a band close to, and within the processes; interspaces minute, hyaline. Border distinct, striæ delicate, 16 in 0·01 mm. Processes 8 to 11, elliptical, with major axis at right angles to corresponding radius, surrounded by a cuneate hyaline space, with sides slightly convex or straight and symmetrical with respect to the processes. The other valve with surface convex. Central space circular, hyaline, about 1/3 of diam. broad. Markings round, granular, increasing slightly outwards towards central space, 8 to 10, towards border 6 in 0·01 mm., rows radial, interrupted near border by an irregular hyaline band, beyond this band the markings forming coarse striæ. Border distinct, hyaline. Processes absent.—*Porodiscus interruptus* Grove & Sturt, Journ. Quek. Mic. Cl., 1887, p. 67, pl. v. fig. 8; Morland, Journ. Quek. Mic. Cl., 1887, p. 167.

Herr E. Weissflog in a letter to Mr. F. Kitton, says that he has been able to confirm Morland's observation of the identity of *Craspedoporus elegans* and *Porodiscus interruptus*.

Habitat: Oamaru deposit (Grove! Doeg!).

ARTIFICIAL KEY.

- |  |                     |
|--|---------------------|
| 1. Compartments not differentiated. Valves dissimilar, the one with, the other without processes. Markings small, round, granular; rows radial .. .. | <i>elegans</i>      |
| "   distinct .. .. .. .. .. .. .. .. .. ..   | 2                   |
| 2. Markings large, areolate, edges of compartments not straight .. .. .. ..  | <i>ralf'sianus</i>  |
| "   minute, punctate, edges of compartments straight .. .. .. ..   | <i>johnsonianus</i> |

ISODISCUS gen. n.

Valves circular. Surface almost flat or slightly convex towards border. Colour pale smoky grey, darker at border. Central space large, rounded, and evident, sometimes absent. Markings angular, areolate, without interspaces, in evident subradial rows converging

somewhat around the processes, or small, round, granular, with evident interspaces largest towards the centre, and arranged without order. Processes low, most prominent towards the border, 2 or 3 larger, sometimes asymmetrical, between these 3 to 8 smaller similar processes at subregular intervals. Border distinct, sharply defined, striæ sometimes indistinct.—*Lampriscus* pro parte Grove & Sturt, Journ. Quek. Mic. Cl., 1887, p. 138; *Eupodiscus* pro parte Grove & Sturt, Bot. Centralbl., Bd. xxxiv. Nos. 15–16, p. 38.

*I. Debyi*.—*Eupodiscus Debyi* Grove & Sturt, Bot. Centralbl., Bd. xxxiv. Nos. 15–16, p. 38.

Diam. 0·12 to 0·125 mm. Surface distinctly convex towards the border. Central space circular,  $\frac{1}{5}$  to  $\frac{1}{6}$  of diam. broad, with a few isolated round granules. Markings areolate,  $4\frac{1}{2}$  to 5 in 0·01 mm., subequal; rows distinct, straight or flexuous, converging around the processes, secondary oblique decussating rows evident. Processes 2, larger, opposite, with rounded inner and outer edges and flattened sides, about 0·02 mm. broad, 3 smaller intervening, about 0·0125 mm. broad, subcircular, roundly elliptical, with major axis at right angles to corresponding radius. Border sharply defined, striæ evident, 5 in 0·01 mm.

Habitat: Oamaru deposit (Grove & Sturt! W. J. Gray!).

*I. mirificus* sp. n.

Diam. 0·1375 mm. Surface almost flat, but slightly convex at border. Central space and rosette absent. Markings small, round, granular, and without order towards the centre; towards the border subangular, more crowded, and in faint radial rows, short rows converging round each process. Processes 2, large, rounded, about 0·02 mm. broad, more protuberant on the outer edge, subopposite; a third similar, but somewhat smaller, about 0·015 mm. broad, at equal distances from the former on one side of the valve; 8 still smaller, 0·0075 mm. broad, on the opposite side between the 2 large processes, and 5 of similar size between the latter and the intermediate process. Border distinct, striæ obscure.—Pl. XVI. fig. 4.

Habitat! Oamaru deposit (W. J. Gray!).

#### ARTIFICIAL KEY.

A central space. Markings obviously areolate, rows evident between central space and border .. .. .	<i>Debyi</i>
No central space. Markings small, round, granular, without order towards centre, nearer border subangular, in faint radial rows.. .. .	<i>mirificus</i>

XII.—*Note on the Large Size of the Spicules of Acis orientalis.*

By F. JEFFREY BELL, M.A., Sec. R.M.S.

(Read 14th November, 1888.)

IN the year 1882, Mr. Stuart O. Ridley described \* a species of *Acis* from Mauritius. A specimen lately purchased by the Trustees of the British Museum from the same island shows that the examples seen by Mr. Ridley were either starved or incompletely grown. In the very much finer example lately acquired the spicules of the cœnenchym are seen to form quite a stout armour for the colony, and the examination of it leads to a few considerations of some interest. The scales may be as much as 7 mm. long. These large plates appear to be scattered quite irregularly over the colony; that is to say they are not more common on one side than the other, on the larger than the smaller branches; they are not more frequently developed at the angles of branching than elsewhere; they are quite irregular in form, but they are always longer than broad, and there is a tendency to a lozenge-shape. The smallest plates may not be more than about half a millimetre along their longest axis, but these are, of course, visible to the naked eye; between these two extremes there are plates of every possible intermediate size.

The plates of the calicles offer a somewhat remarkable disposition; they are arranged in two or three rows of slightly imbricating scales of varying size; often, though not always, the basal scales are larger than those above them; the mouth of the cup is guarded by eight scales, so small as to be only just visible to the unaided eye. These scales exhibit a simplified arrangement of the type which Professor Kölliker has made familiar to us by his figures of *Primnoa lepadifera*, *P. verticillaris*, and *P. regularis*. A somewhat similar, but simpler, striation is seen on the scales of the cortex of the cœnenchym, but the larger plates are almost smooth, and exhibit no characteristic markings. The indentations at the edges, where they unite with their neighbours, offer nothing worthy of notice.

It appears to be obvious that the point of real interest in this species is the remarkable size of the cortical scales; other forms have, before now, been described as having large scales, such as *Thesea exserta* or *Acis guadalupensis*, but the greatest length given by Kölliker for the former is 1·2 mm., and for the latter 2·0 mm. In *Calyptrophora japonica* Dr. Gray reports that the scales are large, but the largest scales, which are not those of the cœnenchym but of the polyps, are not more than 1 mm. in their greatest length. The interest of this large size of the spicules lies in the fact that palæontologists, with the exception of Počta,† seem to have hitherto neglected to look for the deposits of Aleyonarians on account of their small size; or, as Prof.

\* Ann. and Mag. Nat. Hist., x. (1882) p. 126.

† See SB. K. Akad. Wiss. Wien, xcii. (1885) p. 7.

Zittel \* expresses it, "Isolirte Spiculä von fossilen Aleyonarien sind bis jetzt noch nicht mit Sicherheit nachgewiesen worden. Ihre wenige Grösse entzieht sie nach ihrer Zerstreung leicht der Beobachtung und überdies dürfte der reichliche Gehalt an organischer Substanz ihre Zersetzung beschleunigen." Spicules of the size I have described in this paper might, however, be very easily recognized, now that it is known that such exist.†

Evidence of the geological age of such large cœnenchymal plates would be of great value in aiding us to determine whether or no a species with large spicules appeared early in the history of the Gorgonid Aleyonarians. At present we can only argue by way of analogy from what we know about Fishes. The earliest were naked, and such must, of course, have been the case. Some of the latest are naked too; so nakedness *per se* offers us no aid. The oldest scaled forms are, like *Cephalaspis*, formed with great shields. Structurally, we are bound to suppose these great shields were formed by the fusion of granules; some of the youngest, like *Diodon*, have large scales also; so, the possession of large scales is, of itself, no aid. But the very early existence of large-scaled fishes shows that, though not primitive, such a character may have been primæval. And it is possible that the Aleyonaria will be found to exhibit a history analogous to that of Fishes. In the present state of our knowledge the case must be left here. It is to be hoped that microscopists who have the opportunity of examining deposits that may contain Aleyonarian spicules will not fail to look for them.

\* 'Handbuch der Palæontologie,' i. p. 209.

† By a curious error the figure of *Acis guadabypensis* is stated by Duchassaing and Michelotti to be "de gr. nat.," when it is clearly the "portion grossie de la même espèce." Cf. figs. 14 and 15 of pl. i., Mem. Acad. Torino (2) xix.

SUMMARY  
OF CURRENT RESEARCHES RELATING TO  
ZOOLOGY AND BOTANY  
(*principally Invertebrata and Cryptogamia*),  
MICROSCOPY, &c.,

INCLUDING ORIGINAL COMMUNICATIONS FROM FELLOWS AND OTHERS.\*

ZOOLOGY.

A. VERTEBRATA:—Embryology, Histology, and General.

a. Embryology.†

Physics of the Yolk.‡—Dr. H. Virchow reports the results of an inquiry (prompted by the observations of G. Quincke) into the physical conditions which lie behind the microscopic phenomena to be seen in studying the yolk of a fowl's egg. Two questions in particular are raised: in what form is the fatty body inclosed in the yolk-spherules, and in what degree do reagents produce artificial features. Herr Virchow describes the phenomena observed in yolk after retention in alcohol for twenty-four hours, after boiling for half an hour, after treatment for twenty-four hours with concentrated sublimate solution. He gives what seems to be the explanation of some of the differences observable. As to the form the fatty body takes in the spherules, he is uncertain. It is contained, at any rate, in all parts of the spherule, perhaps in the form of fine drops, perhaps in solution in the albumin-body which gives shape to the spherules.

Embryonic Axis.§—Dr. W. Roux replies to certain criticisms made by Herr O. Schultze on his researches in regard to the axes of frog-eggs and embryos. On most points of importance the two investigators differ, indeed directly contradict one another. In the present paper Roux examines the evidence for Schultze's conclusions, and maintains the integrity of his own.

Spermatogenesis of Vertebrates.||—Sig. F. Sanfelice gives a completed account of his researches on the spermatogenesis of Vertebrates

\* The Society are not intended to be denoted by the editorial "we," and they do not hold themselves responsible for the views of the authors of the papers noted, nor for any claim to novelty or otherwise made by them. The object of this part of the Journal is to present a summary of the papers *as actually published*, and to describe and illustrate Instruments, Apparatus, &c., which are either new or have not been previously described in this country.

† This section includes not only papers relating to Embryology properly so called, but also those dealing with Evolution, Development, and Reproduction, and allied subjects.

‡ SB. Akad. Wiss. Berlin, xxxvii. (1888) pp. 977-81.

§ Biol. Centralbl., viii. (1888) pp. 399-413.

|| Boll. Soc. Nat. Napoli, i. (1887) pp. 33-45; ii. (1888) pp. 42-98 (3 pls.).

(Fishes, Amphibians, Reptiles, Birds, and Mammals); and deduces the following general conclusions:—

(1) With a few differences, conditioned by the structural level of the testes, the spermatogenesis of Vertebrates exhibits a constant type.

(2) In Mammals, Birds, and Reptiles, there is some division of labour, for the spermatoblasts produce not only spermatozoa, but also elements destined for the expulsion and nutrition of the essential products. In Amphibians and Selachians, the spermatoblasts form only spermatozoa, expelled by the proliferation of the germinal cells.

(3) The Amphibian spermatogenesis is a median type; a spermatocyst in the canal of an Amphibian corresponds morphologically to an ampulla in the Selachian testes.

(4) The germinal cells, the fixed cells of Sertoli, the "cellules de soutien" of Merkel, represent the matrix of the spermatocyst, giving origin to the new spermatoblasts.

(5) Following Flemming, the author regards as cellular what other investigators describe as nuclei—the elements, namely, which divide to give origin to the spermatoblasts.

(6) The protoplasmic network described by various authorities as originating from the germinal cells and extending between the elements of the testicular canal, is the result of the action of the nuclei of the dividing spermatoblasts.

(7) In Mammals, Birds, and Reptiles, the expulsion of the spermatozoa is favoured by the secretory modification of some of the elements of the canal. In Amphibians and Selachians the expulsion is referable to the proliferation of the germinal cells.

(8) The spermatozoa arise directly from small nuclear asters, and are equivalent, therefore, not to cells, but to nuclei. Both chromatic and achromatic portions of the spermatozoa have nuclear origin. Only in Mammals were two different kinds of spermatozoa to be observed.

(9) The polymorphic nuclei, as yet described only in Amphibians, occur throughout the Vertebrate series.

(10) The physiological regeneration of the epithelium of the canals occurs from the germinal cells, when all the elements produced by the first generation have been expelled. There is a constant relation between the transformation of the spermatoblasts and the proliferation of the germinal cells.

**Spermatogenesis of Reptiles.\***—Dr. A. Prenant has studied the spermatogenesis of reptiles in *Gecko communis*, *Anguis fragilis*, *Lacerta agilis*, and *Vipera aspis*, but especially in the first named.

(1) Spermatogonia, seminiferous, or germinative cells. In these cells the author has especially studied the granular crescent in the protoplasm which forms the "Nebenkern," and has observed the presence of that element itself.

(2) Nematoblasts and Spermatozooids. The nematoblasts exhibit the "Nebenkern." It forms amid a crescent of granules. Its history seems to be that as it becomes differentiated it gains the anterior pole of the nucleus, there becomes less definite, and along with the surrounding protoplasm forms a head-cap. The crescent of granules appears to give rise also to the caudal knob and to the beginning of the caudal filament.

\* La Cellule, iv. (1888) pp. 181-97 (1 pl.).

The nature of the various parts of the spermatozoid is discussed at length, but does not readily admit of summary.

**Fate of the Blastopore in *Rana temporaria*.**\*—Mr. H. Sidebotham, from the examination of more than sixty embryos, is more inclined to agree with the account given by the late Prof. Balfour in his 'Comparative Embryology' than with those of Spencer, Johnson and Sheldon, or Durham as to the fate of the blastopore in the frog. He differs from Balfour in so far as he finds that the neural folds do not inclose the blastopore, the closure of the latter being effected subsequently to the meeting of the neural folds. From Spencer he differs essentially, for he finds that the anus is not derived from a persistent blastopore, but is formed from an independent proctodæal invagination.

**Development of the Frog.**†—In the new third edition of his manual on the Frog, Prof. A. Milnes Marshall has added a chapter on its development, which should prove useful to many classes of students. It is illustrated by several woodcuts, some of which are new and very instructive.

**Eggs of Alligator lucius.**‡—Prof. S. F. Clarke has examined the nests and eggs of the alligator. He states that the eggs are white, elliptical, and varying from 39 to 45 mm. in the shorter diameter, and from 67 to 88 mm. in the longer. The shell is thicker than that of a hen's egg and more brittle, and the shell-membrane is also thicker. The white has the consistency of a very thick jelly, so that it will adhere to the yolk after the shell-membrane is removed; the yolk is spherical, and of the faintest yellow or straw colour; the white forms a very thin pellicle, and as, after the first day, it is almost impossible to get off the membrane without rupturing this thin pellicle, and so breaking the embryo, the eggs are very difficult to work with.

**Eggs and Larvæ of Teleosteans.**§—Sig. F. Raffaele gives a preliminary account of his observations on the ova and larvæ of Teleostean fishes. He starts with emphasizing the necessity for rigorous comparison of pelagic and ovarian eggs, and for making the series of larval forms as complete as possible. He proceeds to describe the characters of certain eggs from the Gulf of Naples, which resemble those referred by Agassiz and Whitman to *Osmerus mordax* Gill. The appearance of the hatched larvæ proved them to be Clupeids, and it seemed likely that they were the common sardines (*Clupea pilchardus*). A noteworthy character, which begins to appear in very young larvæ (15–20 days), is a series of regularly disposed transverse folds of the intestinal mucous membrane, from the pylorus to the anus. This appearance, which recalls the spiral valve of Elasmobranchs, and still more that of Ganoids, has been described by Cuvier and Valenciennes in *C. alosa*, *C. pilchardus*, and in some allied forms. The author believes that hints of natural affinities may be profitably looked for in the structure of the vitellus.

The author also describes || the ova and larval form of the anchovy (*Engraulis encrasicolus*). The eggs had a much elongated ellipsoid form; the very transparent vitellus exhibited large vesicular segments; the delicate capsule was perforated by a single micropyle at the inferior

\* Quart. Journ. Micr. Sci., xxix. (1888) pp. 49–54 (1 pl.).

† 'The Frog,' 3rd ed., 1888, Manchester and London.

‡ Zool. Anzeig., xi. (1888) pp. 568–70.

§ Boll. Soc. Nat. Napoli, i. (1887) pp. 53–8.

|| Ibid., pp. 83–4.

pole. The very young ova had the usual round form; the elongated shape was assumed along with the granulation of the vitellus. The ovarian ova are more minutely described. In regard to the origin of the blastoderm Kupffer's observations are confirmed. The incubation lasts 2-3 days; the larvæ are like those of other Clupeids; the vitellus is prolonged far back in the abdominal cavity, and the yolk-sac has a much restricted and elongated form. The very large notochord, the transverse folding of the post-pyloric portion of the intestine, are then alluded to. Referring to his previous description of *Clupea pilchardus*, the author again emphasizes the vesicular structure of the vitellus as expressing a natural affinity.

**Heredity.\***—Prof. A. Weismann discusses the alleged botanical evidence in favour of the inheritance of acquired characters. In a preliminary discussion the author reiterates the essentials of his often misunderstood position. Individually acquired characteristics, not of constitutional origin, are not transmitted; functional and environmental variations may effect the "soma" of the individual, but unless the reproductive elements be affected there can be no transmission; proof of the transmission of such variations is not forthcoming; the ground is taken from under the feet of Lamarckians; direct germinal modification remains the sole fountain of specific variation. But Detmer and Hoffmann have submitted a number of cases among plants which appeared to these botanists to warrant the conclusion that individually acquired characters might be transmitted. Weismann subjects Detmer's cases to examination, but does not find that any of them warrant the conclusion drawn. All the illustrations given by Hoffmann are secondary variations in consequence of variations in the germinal protoplasm, none of them are directly acquired modifications of the soma. With the former, Weismann has of course no difficulty. Beyond the critique of the two botanical memoirs, the paper contains numerous side-remarks illustrating the author's position.

**Principle of Heredity and the Laws of Mechanics applied to the Morphology of Solitary Cells.†**—M. M. W. Khawkinge has made a study of the development of *Paramecium aurelia*. He observes that a mother-cell of *Paramecium*, in which fission is produced, has an annular constriction but no other depression of the body; on the contrary, its external layer is stretched, its contours are rounded, and the whole of its body approaches the form of a revolving solid. The young organisms when freshly separated have likewise no depression, and approach the same form. Under ordinary conditions the freshly separated *Paramecia* long remain at the same place, working with the cilia of their ventral surface so as to attract food; or the young *Paramecium* may at once begin to swim and turn somersaults in the surrounding water; as this somersault and movement of rotation are always produced in opposite directions, the work is almost exclusively that of the ventral cilia. It is possible that it is the large share in diffusion which obtains in the region of the mouth that is the direct cause of the greater part of the work being thrown on the ventral cilia, and of their elongation and increase in strength; whatever and however it be, the work of these cilia produces a pressure on the whole of the corresponding surface of the body. This

\* Biol. Centralbl., viii. (1888) pp. 65-79, 98-109.

† Arch. Zool. Expér. et Gén., vi. (1888) pp. 1-20.

pressure is quite sufficient to make a deep depression on the whole of the surface covered by these cilia, and it is on this surface that the elongated peristome, which is characteristic of the *Paramæcia*, gradually becomes hollowed out. This depression once produced and retained for a sufficiently long time is preserved of itself; as the ventral cilia work throughout the whole of the life of the *Paramæcium* more than the rest, this buccal depression is assured for ever. As the cilia of the anterior part work much more than those of the posterior, there is a much greater pressure on the first half than on the second, and the former, therefore, appears more compressed. To convince oneself of the truth of these generalizations, it is only necessary to make use of a reagent which stops the work of the cilia and causes the contents of the cell to swell out. Under the influence of such a reagent, e.g. a faint odour of ammonia, water penetrates rapidly into the *Paramæcium* and equalizes its walls. The creature at once returns to the form under which it commenced its existence, and becomes completely rounded.

The author considers that the "law of heredity" must yield to the physico-mechanical cause which underlies it.

**Action of the Environment.\***—Mr. J. Arthur Thomson gives a summary of the influence of the environment upon the organism. The paper is mainly an appendix to Semper's 'Animal Life,' and an expansion of Spencer's conclusion that "the direct action of the medium was the primordial factor in organic evolution." The author first furnishes a tabular analysis of the external factors, and a classified review of typical concrete researches. He proceeds to discuss the physiological classification of the results, the variable susceptibility to environmental influence, the different degrees and periods of environmental action, and the like. The relation of environmental modification to heredity and to "functional" and "organismal" variations are then referred to. In conclusion the author summarizes the history of opinion in regard to the action of the environment as a factor in organic evolution. This "balance-sheet of representative facts and opinions in regard to environmental modification" is backed up by a copious bibliography.

**Elimination and Selection.†**—Prof. C. Lloyd Morgan suggests the use of the term "Natural Elimination" alongside of "Natural Selection." "Variations," he says, "are subjected to a double process—a process of elimination—weeding out the unfit; and a process of selection—choosing out the more fit. Of these, elimination is the more universal, selection only coming into play when intelligence has definitely appeared on the scene of life. Of the three kinds of variations—favourable, neutral, and unfavourable—elimination only gets rid of the unfavourable, leaving both favourable and neutral in possession of the field, except where severe and long-continued competition has rendered even the neutral variations relatively unfavourable. Selection, on the other hand, picks out only the favourable variations; so that under selection alone, the occurrence of useless structures and features would be anomalous. Both principles have been operative under Nature; and both are included under Mr. Darwin's terms, "Natural Selection" and "Sexual Selection."

\* Proc. R. Phys. Soc. Edin., ix. (1888) pp. 446-99.

† Proc. Bristol Nat. Soc., v. (1888) pp. 13.

## B. Histology.\*

**Structure of Red Blood-corpuscles.**†—Signori C. Cianci and G. Angioliella have investigated the minute structure of red blood-corpuscles. Their results agree rather with those of Brücke than of Rollet. They have been able to show the existence of two different substances within the corpuscles, one forming a network, the other an amorphous mass. This has been demonstrated from fishes to mammals.

**Peculiar Fat-cells.**‡—Prof. H. Rabl-Rückhard described a peculiar condition of the fatty tissue which he observed in sections of the head of *Cobitis barbatula*. In the typical fat-cell, the protoplasm of the original connective-tissue cell forms a thin envelope, and no evidence of spontaneous amoeboid movements has as yet been recorded. But inside the head-bones of *C. barbatula*, active protoplasmic movements appear to occur in the envelope of the fat-cell. These find expression in fine "pseudopodia" radiating from the surface of the envelope, and producing an appearance curiously like that of an Actinophrys. Wenckebach has described apparently similar phenomena in the pigment-cells of pelagic fish-ova.

**Karyokinesis in its Relation to Fertilization.**§—Prof. W. Waldeyer republishes in extended form a lecture on karyokinesis and its relations to the phenomena of fertilization. Some portions have been rewritten, and recent researches have been incorporated. The memoir gives an account of the history of research, and presents a critical summary up to date. A useful bibliography from Martin Barry's observations on mammalian fecundation (1840) down to those of Kultschitzky (1888) is appended.

**Reticulum of Muscle-fibre.**||—Sig. P. Mingazzini reports the results of his study of the supposed protoplasmic reticulum in striped muscle. His material was obtained from the crayfish. His principal conclusion is as follows:—The appearance of longitudinal filaments in the plasmic reticulum is referable to the walls of the fibrils; their varied forms along their course are due to the contours of the clear and dark zones, and of the membrane of Krause in the individual fibrils. These images are produced in relation to the particular coagulations caused by various reagents acting on the constituent elements of the striated fibres, and especially on the refractive substance of the clear zone. The appearance of transverse bars is referable to the interstitial substance of Cohnheim's areas.

**Sarcolemma.**¶—Prof. A. Schneider maintains that the bundles of muscle-fibrils in all animals are imbedded directly in the connective tissue, and are not surrounded by a fine structureless membrane, the sarcolemma, as has hitherto been invariably stated. He describes in detail some of his investigations on various animals, and affirms that what, in cross-sections, has been taken for sarcolemma is, in reality, only the boundary-line formed by the minute fibrillar columns coming

\* This section is limited to papers relating to Cells and Fibres.

† Boll. Soc. Nat. Napoli, i. (1887) pp. 67-74.

‡ Arch. f. Mikr. Anat., xxxii. (1888) pp. 182-7 (2 figs.).

§ Ibid., pp. 1-122 (14 figs.).

|| Bull. Soc. Nat. Napoli, ii. (1888) pp. 24-41 (1 pl.).

¶ Zool. Beitr. (Schneider), ii. (1888) pp. 212-18 (1 pl.).

into closer proximity at the edge of the fibre. "The sarcolemma is a delusion. It is so firmly established in the conceptions of histologists, that this short essay will hardly avail to displace it. Nevertheless, in time, it will disappear from the text-books."

**Nervous System of Amphioxus.\***—Dr. E. Rohde has made a detailed investigation of the histology of the nervous system of *Amphioxus*, in continuation of his previous researches on that of *Chætopods*. The chief interest of the memoir lies, on the one hand, in the completeness of the account, but even more in the critical review of other researches bearing on the histology of the nervous system. It does not admit of summary.

## B. INVERTEBRATA.

**Myelocytes of Invertebrates.†**—M. J. Chatin does not agree with the view that myelocytes can be compared to free nuclei. They represent true cells, and possess all the essential parts of these elements. This may be proved with various forms of Invertebrates. These cells are always very small, but they do not vary in size as much as those of Vertebrates ( $6\ \mu$  to  $18\ \mu$ ), for they are never less than  $9\ \mu$  nor more than  $15\ \mu$  long. The protoplasmic portion of the element never occupies more than a narrow peripheral zone, and this explains how it is that it has escaped the attention of many observers; it has often fine granules scattered in its substance. The nucleus, which is always very large and effaces or masks the other parts of the element, is elliptical or spheroidal, rarely polyhedral in form. The nuclear mass is always more granular than the somatic portion of the myelocyte. The nucleoli vary somewhat. The secondary products of the cell are chiefly represented by adipose globules or pigment granulations; the former are generally placed in regions parallel to the long axis of the nucleus, while the pigments are found near the poles of the myelocyte.

According to classical descriptions, the myelocyte of Vertebrates has constantly two prolongations placed opposite to one another. Many Invertebrates (such as *Pontobdella*, *Arenicola*, *Locusta*), have only one process, while other (Gastropoda) have several. The prolongations unite to form a fibrillar network, the nature of which becomes mixed when connective fibres take part in its constitution.

The variations observed in the form of the myelocyte are determined by corresponding variations in the nerve-cells; when all the myelocytes are unipolar the nerve-cells are unipolar too; when the former are multipolar the nerve-cells have generally the same form. The author thinks that there can be no doubt that, histologically, the myelocyte is allied to the nerve-cell, and he doubts whether it should be specially distinguished from other forms of nervous cells.

Anthropotomists have long insisted on the localization of myelocytes in the grey substance or in the retina; in Invertebrates these cells have a very similar mode of grouping; they are chiefly observed in ganglia of high physiological value which give off nerves of special sensibility, and they are found near the optic rods.

**Role of Symbiosis in Luminous Marine Animals.‡**—M. R. Dubois, who has already urged that the fundamental reaction necessary for the

\* Zool. Beitr. (Schneider), ii. (1888) pp. 169–211 (2 pls.).

† Comptes Rendus, cvii. (1888) pp. 504–7.

‡ Ibid., pp. 502–4.

production of light in animals is of the nature of those which are effected under the action of ferments, brings forward some new evidence. He has recently demonstrated the normal presence in the walls of the siphon of *Pholas dactylus* of micro-organisms (*Bacillus pholas*) which give a bright light when cultivated in a nutrient fluid prepared from the phosphorescent tissues of the living animal. These tissues contain the substance which M. Dubois has provisionally called luciferine, and on which the ferment acts. The medium in which it acts must have a suitable chemical composition.

The author considers that he has here to do with a case of symbiosis; another case is afforded by *Bacterium pelagia* and *Pelagia noctiluca*. If this bacterium be cultivated in gelatin it rapidly makes funnel-shaped openings filled with a fluid substance; in this there are a number of more or less long filaments, filled with very small, perfectly rounded spores. By the side of these filaments there are free spores and some mobile rods which become spore-bearing filaments. In pure gelatin these filaments are not luminous, but if placed in nitrogenous bodies which contain phosphorus, such as nuclein or lecithin, they give rise to a beautiful bluish phosphorescence in the parts which are in contact with air.

It is possible to collect in these cultivation fluids the characteristic doubly refractive substance which forms the chalky layer of the luminous tissue of various insects, as well as other animals, and the existence of which has been recognized by the author in the phosphorescent seawater of Mentone. In chemical characters this body somewhat resembles leucin. In addition to it there are found a number of phosphatic crystals which are almost all formed by the oxidation of the phosphorized nitrogenous substances which are found in the cultivation fluid.

The author thinks that these researches enable us to reconcile the theory of photogenic fermentation with the hypothesis of some authors that there is an oxidation of a phosphorus-containing body.

**Distribution by Birds.\***—Prof. O. Zacharias notes that although the transportation of lower aquatic animals by migratory swimming-birds has long been accepted as affording a possible explanation of the similarity of the fauna in widely separated inland basins, until recently little has been done to find out definitely what animals might be thus distributed. M. Jules de Guerne has lately made a careful examination of the organic contents of particles of slime adhering to the feathers, bills, and feet of wild ducks (*Anas boschas*). The webbed feet were washed with especial care, and a microscopic examination of the water revealed the presence of little nematods, rotifers (*Philodinidæ*), rhizopods (*Trinema enchelys*), diatoms, desmids, numerous encysted organisms, isolated Cladocera-eggs, pieces of Polyzoan-statoblasts (*Plumatella*), and the shell of an ostracod (*Cytheridea torosa* Jones). Spores and cysts were also found in slime-particles taken from the feathers.

## Mollusca.

### a. Cephalopoda.

**Gigantic Cephalopoda.†**—In an anonymous article on gigantic Cephalopoda, in the compilation of which considerable use has been made of Prof. Verrill's well-known researches, it is stated that a blood-

\* Biol. Centrbl., viii. (1888) pp. 368-9. † Naturforscher, xxi. (1888) pp. 231-3

red Decapod measuring more than 28 feet was observed in 1886 at Cape Campbell, New Zealand.

**Germinal Layers in Cephalopods.\***—Mr. S. Watase gives a more detailed account of his investigations on the homology of the germinal layers in Cephalopods (*Loligo pealii*). His more important results in regard to the "yolk-membrane" and the phenomenon comparable to an epibolic gastrula have already been reported.†

The "yolk-membrane" is a true endoderm and its sole representative in the Cephalopods. The digestive tract with its appendages is entirely formed by the ectodermic invaginations, by the prolongations of the proctodæum and stomodæum. At no period of development is there any connection between the "yolk-membrane" and the digestive tract, and long before the absorption of the food-yolk is completed the permanent digestive canal is formed. With the absorption of the food-yolk the "yolk-membrane" disappears.

The consequences of the gradual increase in the size of the yolk, as emphasized by Ryder for the Vertebrate series, apply with equal force in the Molluscs. "The endoderm in the highest group, the Cephalopoda, is made a temporary embryonic structure which may be said to have no chance of leaving traces of definite structure in the organization of the adult, and the set of secondary digestive organs in addition to the primary one is developed from an entirely different source, the ectoderm." This may possibly be an extreme instance of the influence which the food-yolk exerts in modifying the course of development and the history of the germ-layers.

**Olfactory Ganglia of Cephalopods.‡**—Sig. G. Jatta has investigated the so-called olfactory ganglia of Cephalopods, and comes to the following conclusions:—(1) The so-called olfactory ganglia include a true ganglion and a mass of connective tissue; (2) the ganglion is united to the cerebral by means of nerve-fibres; (3) it may be considered as accessory to the otic ganglion; (4) the mass of connective tissue which in the Cephalopods with more evolved nervous system tends to be less distinct from the ganglion to which it adheres, may perhaps be regarded as itself representing a ganglion, which tends to disappear with cessation of function.

Continuing his observations § he discusses the origin of the olfactory nerve. His investigations were based on *Sepia*, *Loligo*, *Eledone*, and *Octopus*, and warranted him in concluding that the olfactory nerve of Cephalopods arises from the supra-oesophageal ganglion, called by Dietl the superior frontal ganglion.

**Some Oigopsid Cuttle-fishes.||**—Mr. F. E. Weiss has made a careful examination of the cuttle-fishes in University College, London. He has studied, among the Oigopsida, *Chiroteuthis Veranyi*, *Doratopsis vermicularis*, *Histioteuthis Rueppelli*, *Tracheloteuthis Behni*, and *Verania sicula*. He comes to the conclusion that the family Chiroteuthidæ should be retained, but not on the grounds formerly given, namely the absence of siphonal valve, loss of accessory nidamental glands and of one of their oviducts. The various leading points of agreement are pointed out.

\* Stud. Biol. Lab. Johns-Hopkins Univ., iv. (1888) pp. 163-83 (2 pls.).

† This Journal, 1888, pp. 396-7.

‡ Bull. Soc. Nat. Napoli, i. (1887) pp. 30-33.

§ Ibid., pp. 92-3.

|| Quart. Journ. Micr. Sci., xxix. 1888) pp. 75-96 (3 pls.).

**Organ of Verrill in *Loligo*.**\*—Mr. M. Laurio has discovered in a young *Loligo* about 6 mm. in length an organ which appears to be homologous with the valve-like organ described by Verrill at the base of the siphon in *Desmoteuthis* and *Taonia*. It consists of a median dorsal cushion, which is prolonged backwards with two large processes, and a pair of lateral cushions on the ventral wall of the siphon. The organ is glandular in structure. It is well developed in specimens of *Ommastrephes* about 8 mm. long, but there is no trace of it in adults of that genus or of *Loligo*; it is probably, therefore, an archaic organ, but cannot be compared with anything known in Gastropods.

**Salivary Glands of *Sepia officinalis* and *Patella vulgata*.**†—Dr. A. B. Griffiths has found that the salivary secretion of the cuttle-fish converts starch into glucose; mucin, sulphocyanates, and what seemed to be phosphate of calcium were found in the salivary secretion. Similar results were obtained with the limpet. The subjoined table gives a résumé of the author's already attained results.

	Cephalopoda.	Gastropoda.	
	(a) Dibranchiata.	Pulmogastropoda.	Branchiogastropoda.
Soluble diastase ferments	Present	Present	Present
Mucin .. .. .	Present	..	Present
Sulphocyanates .. ..	Present	(?)	Present
Calcium phosphates ..	Present	(?)	Present

The salivary glands of these molluscs seem to have the same functions as those of Vertebrates.

#### γ. Gastropoda.

**Spermatogenesis of Gastropods.**‡—Dr. A. Prenant describes the spermatogenesis of Pulmonate Gastropods (*Helix*, *Arion*), and draws the following principal conclusions. (1) The resting spermatogonium includes peculiar cytomicrosomata, which are the rudiments of the "Nebenkern," or it may contain the perfect Nebenkern itself. It may also exhibit other structures, described by Platner in Lepidoptera as well as Gastropods, and regarded by him as distinct from the Nebenkern. (2) In division the initial phase of the karyokinesis exhibits a remarkable mode of "pelotonnement" and transverse fission, as Platner observed, though Prenant's details differ from those of the previous investigator. (3) The Nebenkern appears to the author to develop indirectly, not directly, from the spindle. Vestiges of the spindle form special cytomicrosomata, which give rise to the Nebenkern.

(4) In the spermatides, the Nebenkern takes part along with the protoplasm in forming the spiral filaments of the envelope of the axial filament. The long caudal filament described by Platner as the head-piece, seems to the author to result from the median portion. The axial filament is formed in its anterior portion of two or more superposed knobs, as Jensen has described in mammals. The differentiation of the spermatide nucleus is described at length.

\* Quart. Journ. Micr. Sci., xxix. (1888) pp. 97-8 (1 pl.).

† Proc. Roy. Soc., xlv. (1888) pp. 327-8.

‡ La Cellule, iv. (1888) pp. 137-77 (2 pls.).

**Classification of Gastropoda by the Characters of the Nervous System.\***—Dr. P. Pelseuer has some critical remarks on the attempt made by Prof. Lacaze-Duthiers to arrange the Gastropoda by the characters of their nervous systems. He regrets that that anatomist did not include in his scheme the Amphineura, Heteropoda, and Pteropoda. It seems unnecessary to give new names to groups whose boundaries remain unaltered. Various instances are cited in which animals have not the anatomical disposition of parts which is assigned to the group to which they belong. The five "orders" of M. Lacaze-Duthiers do not appear to be of the same systematic importance, and that of the Notoneura does not seem to be natural. M. Pelseuer thinks that the imperfections of the new system are due to the inexact interpretation of the morphological value of the pleural ganglia which falsifies the very basis of the system. These ganglia do not belong to the visceral commissure, that is to the asymmetric centre, but to the anterior symmetrical group of the nerve-centres. Moreover it is easy to show that the pleural ganglia do not fuse with the asymmetric or visceral centres, while they often do fuse with one or other of the two anterior pairs.

**Structure and Development of Egg in Chitonidæ.†**—Dr. P. Garnault differs from Prof. Sabatier in his account of the development of the egg in Chitonidæ. He finds that the egg is developed at the expense of the germinal epithelium which lines the ovary; the membrane which surrounds it is always composed of nucleated cells, formed by the transformation of sister-cells of the ovum; this membrane may be called follicular, and it is, contrary to the opinions of Ihering and Sabatier, the only one which is ever formed round the egg. The author finds that the inclosing vitelline masses do not take any part in the formation of the nuclei of the membrane. An account is given of the expansion and retraction of the vitelline masses; these may be considered as the highest known expression of the faculty, possessed by all eggs, of emitting amœboid expansions. The author also describes in some detail the characters of the membrane of the ripe egg.

**Organization of Dentalium.‡**—Dr. L. Plate has been induced to study *Dentalium* by the suggestion of Grobben that the Scaphopoda are the ancestors of the Cephalopoda. The glandular cells on the margin of the mantle are of extraordinary length, and are swollen out at either end. They are succeeded by a layer which seems to be formed of a kind of gelatinous tissue, delicate connective-tissue and muscular filaments lying radially and vertically in a hyaline ground-substance. Further back the mantle-zone becomes quite muscular. On the inner edge there is again a well-developed glandular zone, the elements of which have the form of short flasks. Between it and the outer muscular ring there is a system of irregular blood-lacunæ. The muscles consist of rounded smooth bundles of fibrils; each of these is invested by a delicate membrane; the elongated nuclei lie below this membrane and externally to the fibrils.

The author does not agree with Lacaze-Duthiers in regarding the elongated swellings which lie outside the cerebral ganglia as secondary appendages of these centres, but as independent ganglia which are connected by two commissures, on the one hand with the brain and on the other with the pedal ganglia. Dr. Plate thinks there is no doubt that

\* Bull. Soc. Zool. France, xiii. (1888) pp. 113-5.

† Arch. Zool. Expér. et Gén., vi. (1888) pp. 83-116 (2 pls.).

‡ Zool. Anzeig., xi. (1888) pp. 509-15.

they are the homologues of the pleural ganglia of Gastropods. The cerebropleural commissure in *Dentalium* is very short; the cerebropedal and the pleuropedal commissure run together for almost their whole course, and appear indeed to be closely fused with one another. The author cannot confirm Fol's statement that the ganglionic cells are all unipolar, and in all the nerve-fibres he finds scattered nuclei.

Both Lacaze-Duthiers and Fol have failed to notice that there are two kinds of tentacles, which may be distinguished as "true" and "rudimentary"; the former are placed on the outer and the latter on the inner side of the lamelliform fold, which lies beside the cerebral ganglia; the former are, moreover, very long, hollow, and contractile, and have a subepithelial muscular layer, which extends through the whole length of the tentacle; internally there is a nerve which swells out at the widened end of the tentacle into a ganglion. Nerves, muscles, and cilia are absent from the short solid rudimentary tentacles. There are some intermediate stages between these two kinds of tentacles. Special sensory organs are found in the end-bulbs of the true tentacles, in the form of about a score of long richly granular cells of a nervous character. They are continued into a filament which swells out into an elongated club just in front of the elongated pit which is found on the ventral surface of the terminal bulb. The thick end of this passes through the cuticle and carries a number of small sensory rods. This is a form of tactile organ which does not seem to have been before observed in the Mollusca.

The otocysts have a low epithelium which carries a number of isolated tufts of cilia; the auditory nerve spreads out on the outer side of the epithelium, and, on the other side, soon fuses with the commissure which extends from the pedal ganglion to the nervous centres above the oesophagus.

The epithelium of the two lateral pouches in the oral cone differs from that of the true buccal tube only in the want of cilia; these diverticula must consequently be regarded as labial pouches and not as salivary glands. No suggestion can be offered as to the function of the glandular swelling on the rectum, which contains on its better developed side a multiramified caecal process of the rectum, which is lined by a ciliated epithelium.

The renal tube of one side has a much wider lumen than that of the other; neither has an internal orifice. The walls consist of a simple non-ciliated epithelium, and their secretion is granular. Fol is correct in saying that there is no special efferent duct for the gonads, the products of which make their way to the exterior through the kidneys. The head of the spermatozoon is divided into a long median piece and two short terminal pieces. The tail is long and extends through the whole length of the head in the median line.

There are no vessels, sinuses, or lacunæ from a histological point of view, blood-spaces with true walls being completely wanting. The structure of the "water-opening" on either side of the anus does not seem to have been correctly apprehended by previous workers. The epithelium of the body-wall is, at these points, arranged in several layers, and forms on either side a slight elevation, the cells of which have a remarkably clear protoplasm; a few muscles are connected with the orifice. In the living animal these orifices are ordinarily kept closed, and are only suddenly opened and as suddenly closed. There is

no certain evidence that these pores allow of the direct entrance of water into the blood. The blood-corpuscles may be large or small, and the two kinds differ somewhat in the structure of their nuclei.

There can be no doubt that a genus of Mollusca which has no heart, no internal renal orifices, and no gills, must occupy an isolated place in the system. Dr. Plate believes that Lacaze-Duthiers was wrong in ascribing to it a greater affinity with the Lamellibranchs than with the Gastropods. The single shell, the possession of jaws and a radula, and the whole arrangement of the nervous system, especially the existence of two pleural ganglia, are signs of Gastropod affinities. The so-called oral cone ought to be regarded as a head, the eyes and appendages of which have been lost, as in *Chiton* and some other forms. On the other hand, the hypothesis that *Dentalium* is the ancestor of the Cephalopoda cannot be supported; there is no greater resemblance than there is between a Cephalopod and any Gastropod which has retained its bilateral symmetry. There are great difficulties in homologizing the tentacles of *Dentalium* with the arms of the Cephalopoda, for, *inter alia*, the former are at the base and the latter at the tip of the head, and there are considerable differences in the supply of their nerves.

#### 5. Lamellibranchiata.

**Structure of Muscles of Lamellibranchiata.\***—M. R. Blanchard has studied the structure of muscular tissue in various lamellibranch molluscs. He finds that the constituent element is a fibre-cell 1 to 2 mm. long, and 4 to 38  $\mu$  wide; the nucleus is superficial and marginal, and has no enveloping membrane. This fibre is fundamentally structureless or, at most, is infiltrated with fine granulations, but it often presents a longitudinal striation. This last varies much in distinctness, for at first it is only feebly differentiated. In this case the surface of the cell often presents various ornamentations; this structure is inconstant, and the author is unable to suggest an explanation of it; all that can be certainly said is that it would be a great mistake to compare it to true transverse striation, or, as M. Fol has done, to regard it as due to the spiral rolling of the fibrils. In some further points M. Blanchard is in disagreement with M. Fol, with whose observations he deals more fully in another communication.†

**Formation of Byssus.‡**—Dr. L. Reichel communicates the results of his investigations on the formation of the byssus in Lamellibranchs. These results are based chiefly on the observation of living specimens of *Dreysena polymorpha*, and on microscopic examination of sections of the foot, the byssus-cavity, and the byssus of the same animal. Preparations of *Mytilus edulis* and *Pinna* were used for comparison. The bulk of the memoir is occupied with a discussion of the attaching function of the byssus, and with the details of its development. Dr. Reichel affirms that the byssus arises as a cuticular formation, and that it is not a permanent structure which lasts the animal its lifetime, but that, like the skin of Arthropods, it can be thrown off, and gradually replaced. The throwing off of the byssus is accompanied by a degeneration of the byssus cavity. The walls of partition are reduced, and the cavity becomes a simple groove, but they are formed anew when a new byssus arises.

\* Bull. Soc. Zool. France, xiii. (1888) pp. 74–81.

† Tom. cit., pp. 49–55.

‡ Zool. Beitr. (Schneider), ii. (1888) pp. 107–32 (1 pl.).

## Molluscoida.

## β. Bryozoa.

**Movements of Polypides in Zoëcia of Bryozoa.\***—Dr. J. Jullien has a note on the protrusion and return of the polypide in the zoëcia of monoderm cheilostomatous Bryozoa. He points out that, when a polypide wishes to emerge from its cell it must yield its place to a quantity of water of equivalent volume. But the zoëcium is rigid. The operation is effected, as the author has seen in a specimen of *Catenicella ventricosa*, by the posterior edge of the operculum. This operculum is articulated laterally, and while it closes the tentacular sheath anteriorly it closes posteriorly a second cavity, which is the pouch into which the sea water penetrates when the polypide emerges. In *Schizoporella* the operculum has a small tooth on its lower lip; this is lowered when the polypide is being protruded, and keeps the orifice of the water-chamber widely open. When the polypide returns to its cell the water is driven out, and the operculum is closed over the whole orifice, which, therefore, is not only the opening of the tentacular sheath, but also that of the compensatory water-chamber.

**Ontogeny of Marine Bryozoa.†**—Dr. W. J. Vigelius finds that his observations corroborate in many important particulars the work of M. J. Barrois. The form of the young sessile primary animal is at first more or less rounded, but later becomes elongated, and has somewhat the form of the sole of the foot. Longitudinal sections show that the development of the nutrient apparatus commences with an invagination of the aborally placed disc-organ. The cells which form this invagination are considerably elongated, and lie in a single layer which, later on, forms the epithelium of the enteric canal. Around this invagination there arises later a second cell-layer which is made up of much smaller flattened cells. The author believes that this layer arises, in *Bugula calathus*, from the mesodermal larval tissue. He has never, like Ostroumoff, found any rudiment of hypoblast taking part in the formation of the bud. The number of spines is inconstant in the primary animal, and the buds always arise terminally.

**Cristatella mucedo.‡**—Dr. J. Jullien finds that the male organs of this Bryozoon are formed of seminiferous vesicles, or male ovules or mother-vesicles, in which the spermatozoa are developed; they are suspended to the intracolony trabeculæ. He declares that the colonial disc is not a true foot, and that the direction taken by it may be in its long or in its broad axis. On twenty-five regular lophophores he counted from 71 to 80 tentacles, and on nine irregular lophophores from 3 to 70.

**Delagia Chætopteri.§**—Prof. J. Joyeux-Laffuic gives a full account of this interesting new Bryozoon, the preliminary notice of which we have already recorded. || Part of the colony may be fixed on the inner wall of the tube, and the rest placed more deeply, though always near the inner wall. The zoëcia are oval, flattened along the plane of the

\* Bull. Soc. Zool. France, xiii. (1888) pp. 67-8.

† M. P. Zool. Stat. Neapel, viii. (1888) pp. 374-6 (1 pl.).

‡ Bull. Soc. Zool. France, xiii. (1888) pp. 165-6.

§ Arch. Zool. Expér. et Gén., vi. (1888) pp. 135-51 (1 pl.).

|| See this Journal, 1888, p. 403.

lamella of the tube which carries them, and have the general form of an urn. The walls are formed of two layers, the outer of which is delicate, chitinous and structureless; this is the ectocyst; the endocyst is cellular, and thickest in the median region. The term spherules is applied to two rounded masses which are placed symmetrically on the sides of the zoecia; they consist of a central cavity, which is filled with liquid, and occupies the greater part of the spherule, and of a resisting wall formed by the ectocyst and endocyst. Their function appears to be that of protective organs, acting passively by preventing the compression of the zoecium by the *Chaetopterus*. Morphologically, these bodies appear to be modified individuals. The colony may be considered as formed of a series of differentiated segments placed one behind the other; the polypide has from 12 to 14 tentacles, and a gizzard.

**Fresh-water Bryozoa.\***—Herr F. Braem has been led to disbelieve in the theory that a new polypide may arise at any point of the body-wall by the invagination of its two layers, for he has always found that the formation of young buds is connected with the pre-existence of older ones. He thinks he can show that no bud arises in the colony which cannot be referred to the embryonic cell-material of an older bud-rudiment. If we take a bud *a* at an early stage, when it merely represents a two-layered sac, we find it to give rise to a daughter-bud *b*; as these become separated from one another a second bud *b'* appears between them; and this may be repeated as long as the primary bud is provided with material which is capable of division. Similarly the daughter-buds may give rise to other buds, until at last the youngest individuals are no longer capable of germination.

The inner layer of the bud becomes fashioned into the ectoderm, while the outer forms the inner epithelium of the wall of the cystid; the cells of the latter are partly differentiated into the muscular tissue of the integument and of the gut, and partly give rise to the retractor and folding muscles, and to long unicellular filaments which connect the polypid and cystid. The difference in the rapidity with which the bud-generations follow one another is the cause of the delicate branched colonies like those of *Fredericella* and *Plumatella fruticosa* on the one hand, and the more compact colonies of *Alcyonella* on the other. Further differences may, at last, result in the formation of a *Cristatella*. This last is to be regarded as a colony of Phylactolœmata with creeping individuals which have become so approximated to one another that their cystids have fused laterally; the sum of the basal parts of the cystids becomes the foot, and that of the dorsal pieces, with the orifices, the upper covering of the apparently unjointed colony. The metamorphosed lateral parts appear to be septa in the interior of the common body-space, and there are consequently only radial septa, for those which have been described as being perpendicular to these do not exist. The manner in which the buds follow one another in *Cristatella* is essentially the same as in other Lophopoda.

In all the Phylactolœmata observed by the author the statoblast gives rise to a single primary individual, which forms the stock by budding in the same way as the younger branches are developed later on. The funiculus of *Cristatella* arises at the time when the gastric space is cut off in the lower part of the saccular primary knob by the

\* Zool. Anzeig., xi. (1888) pp. 503-9, 533-9.

infolding of its two lamellæ. In the median line the cells of the outer layer become raised up in the form of a longitudinal ridge, which is bounded laterally by the continuation of the gastric folds. This ridge becomes separated from the mother-tissue and forms a connection between the body-wall and the base of the bud-sac. The funiculus is bilaminate at its point of origin; the ingrowth of ectodermal cells gives rise to the material from which the future statoblasts are built up. In the course of growth the origin of the funiculus becomes more and more separated from the polypide to which it belongs, and we find it at last at the peripheral boundary of the colony just above the foot. The author denies the secondary division of the cell-aggregates which form the statoblast into a cystogenous half and a formative mass, for the two arise quite separately from one another. In *Cristatella* the former arises as a blastula-like sphere, and is probably derived from a single cell.

The cells of the formative mass gradually take on the form of spindles, and at the same time their contents wander round the yolk-spheres until at last the nucleus alone remains visible. The inner layer of the cystogenous half forms the ectoderm; the inner epithelium of the body-cavity and the muscles of the embryo arise from the cells of the formative mass. All the buds are richly nourished by the yolk, which remains in the closest connection with the cells of the inner epithelium, and consequently also with the cavities of the lophophore which are lined by it.

The spermatozoa of *Cristatella* do not develop on the funiculus, but on the septa, and generally near the upper surface. The ova, as in *Plumatella*, are developed on the oral side of the cystid. In most points which he notes the author is found to differ from Verworn, but he confirms that observer's statement as to the presence of an excretory organ in *Cristatella*.

#### Arthropoda.

**Eyes of Arthropods.\***—Dr. W. Patten continues his account of the structure of the eye of Arthropods by a history of the development of those of *Acilius*. He finds that the larval optic ganglion is composed of three segments, each of which is united with a segment of the brain on the one hand, and with a segment of the optic plate on the other. Each segment of the optic plate bears a pair of eyes. The ocelli are composed of four or more sensory spots or pits, each of which is supplied with a separate cuticular thickening and a nerve; in the centre of each group of four sensory pits there is a single large nucleus, the significance of which is not yet understood. The pits of each eye finally unite to form a thickened patch of ectoderm, with a median double row of gigantic cells and a common cuticular thickening. The thickened ectoderm is invaginated to form an optic vesicle, the inner walls of which form the retina, while the surrounding indifferent ectoderm forms a third layer of cells over each vesicle; in this way a typical three-layered eye is produced.

In the embryonic stages of eyes I.-IV., the retinæ of which are invaginated without the formation of a cavity in the optic vesicle (unless, indeed, the space between the median row of gigantic cells be

\* Journal of Morphology, ii. (1888) pp. 97-190 (7 pls.).

such), all the rods are horizontal; in the full-grown larvæ the smaller outermost rods become upright, but those that are larger and deeper retain their horizontal position. In eye V. there is at first a strong tendency to form horizontal rods, but the laterally flattened optic vesicle expands and forms a spacious cavity in the vesicle; all the rods, except those of the median row of gigantic cells, become upright. In eye VI., which has no median row of gigantic cells, no horizontal rods are formed.

The outer wall of the optic vesicle in eyes I.-IV. seems to be absent, its presence in the embryo being only indicated by a few characteristic nuclei between the retina and the corneagen. In eye V. the outer wall of the optic vesicle is represented by two great masses of inverted, rod-bearing cells, which are probably derived from two corresponding sensory spots. In eye VI. the outer wall is composed of a thin nucleated membrane, and a cluster of inverted retinal cells derived from a sense organ.

Eye I. is composed of at least nine sensory spots, four of which, with their central nucleus and median row of giant cells, give rise to the horizontal retina; four more, exactly like the first, give rise to the vertical retina, and the ninth spot to the appendage. All these sense spots unite to form a simple homogeneous organ; but, during the later stages, the three groups of sensory spots become greatly modified, so that in the adult eye the parts to which they give rise are very different in structure. All the retinæ are composed of retinophoræ, formed by the union of two cells; they contain two nuclei and two rods, and are supplied with axial and external nerve-fibres. Ganglionic cells are rarely found in the retina of *Acilius*. The rods are arranged in pairs, which form a mosaic of hexagonal figures when upright, and straight vertical lines when horizontal. In both sets the retinidial fibrillæ are set at right angles to the rays of light.

All the larval ocelli of *Acilius* and of *Dytiscus* contain more or less distinct dimorphic retinal cells. The giant cells always form a double row along the bottom of the furrow; their free ends are bent at right angles, and bear short, but broad, horizontal rods. The ends of the smaller retinal cells, and, consequently their rods, may be horizontal, upright or inverted. Between the two rows of giant rods are two sheets of coarse, vertical nerve-fibres and a layer of medulla-like substance. The pigment granules are deposited on the surface of the retinophoræ and around the external nerve-fibres.

All the eyes are developed from the optic plate—the thickened distal edge of the cephalic lobes. On the proximal edge of this optic plate is a semicircular furrow, which gives rise to the optic ganglion. The furrow is deepened to form two distinct pockets which give rise to the first and second segments of the optic ganglion. The third segment is formed by an inward proliferation on the proximal side of the third segment of the optic plate. The innermost walls of the ganglionic segments are, from the earliest stages, connected with the inner face of the optic plate. Numerous ganglionic cells arise from the optic thickening, and wander along the optic nerves into the optic ganglion. Towards the close of this process, at about the time when the invagination of the sensory areas begins, enormous tripolar cells are formed in each eye, which pass along the optic nerve from the eye to the optic ganglion, dividing rapidly on the way, and producing small tripolar ganglion-cells. Only one of

the proliferating cells retains its great size throughout life, and this finally takes up its position on one side of the medulla belonging to the eye from which it arose.

The author thinks that the history of these cells affords excellent evidence in proof of the theory which explains the presence of intercellular nerve-fibres, by supposing them to be the outer ends of sensory cells, now converted into ganglionic cells.

The optic ganglion of the convex eye of Arthropods is composed of three lobes; the first always, and the third sometimes, disappear; the second gives rise to the optic ganglion proper. The retinal ganglion is a secondary product, and is not formed by invagination. The three-lobed optic ganglion of the convex eye of Arthropods is derived from a three-segmented larval ganglion, every segment of which belongs to a pair of larval ocelli. The first, second, and third segments of the optic ganglion of *Acilius*-larvæ are respectively homologous with the second, first, and third lobes of the optic ganglion of the compound eye, and so it follows that the optic ganglion proper of the compound eye is derived from the first segment of the larval ganglion, or that one which is united with the large, posterior, dorsal ocellus. The optic ganglion contains six medullæ, every one of which corresponds in structure to that of the ganglion to which it belongs, and this indicates that the arrangement of the medullary fibrillæ is as nearly like that of the retinidial fibrillæ as existing conditions will allow.

The structure of the retina in the larval ocelli of Insects is much like that of Myriopods, and the whole eye is composed on the same plan as that of *Peripatus* and of most Molluscs. Mr. Patten believes that the primitive ganglion-cells were tripolar, and were derived from tripolar neuro-epithelial cells. The outer extremities of these cells were reduced to intercellular nerve-ends, the bases of which, in *Acilius*, became the protoplasmic prolongations of the ganglion-cells, and are, probably, homologous with the axis-cylinders of Vertebrates.

**Spermatogenesis of Arthropods.\***—Prof. G. Gilson concludes his series of comparative researches on the spermatogenesis of Arthropods. The first part of his memoir contains an account of the spermatogenesis of Gamasidæ and Ixodidæ. (1) The mother sperm-cells multiply solely by binary segmentation. (2) Each resulting sperm-cell contains a large nucleus, rich in karyoplasma, lodging a nucleolus. The cell elongates, the nucleus likewise, the nucleolus retains its form. (3) The adult spermatozoa are free and immobile, but exhibit movements in the female.

The greater part of Gilson's memoir is devoted to a synthetic survey of his previous results. Throughout Arthropods, he discusses the structure of the spermatozoa as regards form, nucleus, and protoplasm, and then notes the condition of the adult sperms when free or contained in the manifold spermatophores. His general conclusions are disappointing. He first notices the generalizations of Kölliker, Schweigger-Seidel, and de la Valette St. George, but does not admit that they are general or complete. Nor is he satisfied with the theory proposed by Sabatier, nor with the homologies pointed out by P. Geddes and J. A. Thomson. Gilson himself distinguishes three stages of cell-multiplication and differentiation, but maintains the impossibility of formulating any law of spermatogenesis.

\* *La Cellule*, iv. (1888) pp. 351-446 (1 pl.).

**Striped Muscle of Arthropods.\***—Herr A. v. Gehuchten has re-investigated the much studied structure of the striated muscles of Arthropods. He distinguishes the yellow muscles of the appendages from the white muscles of the wings.

(1) The muscles of the appendages. After describing the well-known phenomena, the author notes the differences observed when the reagent is coagulatory in its action and when it is dissolvent. In the fibre there are two portions, one soluble in dissolvent reagent, the other persistent. The latter has a structure and takes the form of a network—it is the protoplasmic reticulum. The former is more or less fluid, rich in albumen and especially in myosin, it is the “enchylème myosique.” These two portions exist in the living fibre; the transverse striæ of the clear zone and the longitudinal filaments of the darker band belong to the reticulum; the dull and homogeneous basis of the dark band is the enchylema. With a coagulating reagent the reticulum is rendered stiff and brittle; in the enchylema the albuminoid substances are coagulated around the longitudinal trabeculæ of the reticulum. The phenomena of discs, fibrils, &c., are explained in terms of these observations, and the structural identity of muscle-cell with any ordinary cell maintained.

(2) In the muscles of the wings, the structure is quite different. There one finds the fibrils of Krause. Each fibril is inclosed in a cylindrical tube divided into cases by complete transverse membranes. The divisions are filled with enchylema. The fibrils are usually united into bundles (without sarcolemma) by interfibrillar granular substance. The striated muscles of Vertebrates agree in structure with what has been described in regard to the muscles of Arthropod appendages. Finally the complicated structure of the nuclei of the muscles in the frog is described.

#### a. Insecta.

**Primary Segmentation of the Germ-stripe of Insects.†**—Prof. v. Graber has been investigating the early stages of development in Insects. He finds that the germ-band is at first either discoid (as in *Stenobothrus* and *Æcanthus*) or more elongated (as in *Hydrophilus*, *Lina*, &c.). The discoid portion corresponds chiefly to the antennary segment, while the primitive trunk has at first a comparatively slight extension. In a few cases two transverse grooves arise simultaneously, thus giving rise to three primitive segments, which appear to correspond to the three primary divisions of the adult body (head, thorax, and abdomen). The primitive trunk of the germ-band of *Stenobothrus* and *Æcanthus* is not segmented, as has been hitherto supposed for Insects, into the permanent segments (metameres or microsomes), but three larger sections (macrosomes) are formed. Of these three segments of the primitive trunk the first correspond to the sum of jaw-bearing metameres, the second to the sum of leg-bearing metameres, and the third to the abdomen. In the primary or macrosomic segments of the primitive trunk of *Stenobothrus* there is not merely an external jointing, but a complete division of the hypoblast.

The secondary or microsomic segmentation of the primitive trunk does not in *Stenobothrus* and *Lina* (any more than in Spiders—Morin)

\* Arch. Anat. u. Physiol. (Physiol. Abth.), 1888, pp. 560-4.

† Morphol. Jahrb., xiv. (1888) pp. 345-68 (2 pls.).

progress, as is ordinarily supposed, from before backward, but first affects the median or thoracic primitive segment.

It is clearly difficult to explain the tetramerism of the segmented primitive stage by the trimerism of the terminal stage, but it is clear that it must have some relation to certain stages of segmentation in the ancestor of the Insect, though none to any such few-jointed Arthropod form as, for example, the *Nauplius*.

**Germinal Layers of Meloe.\***—Dr. J. Nusbaum gives a preliminary account of part of his researches on the embryology of the Meloidæ. He discusses the establishment of the germinal layers in *Meloe proscarabæus*, which appears to be exceedingly well suited for such investigations.

The segmentation nucleus divides into two, these into many vacuolated cells, which are scattered in the yolk and connected by fine anastomosing processes. Some of the cells remain in the yolk to form the so-called yolk-cells, others approach the surface and form a layer of blastoderm. On the third day the ventral plate and rudiment of the amnion are apparent; the former becomes segmented and the appendages become marked out; along with the development of the amnion the ventral groove becomes distinct, progressing from behind forwards, representing as in other insects the gastrula invagination.

From the disguised invagination a solid strand of primary endoderm or endo-mesoderm results. This exhibits by the 7th–8th day a special posterior mass of cells, which on the 9th–10th day mingle with the yolk-cells, but have nothing to do with the mesenteron. The primary endoderm is differentiated into two large, paired, lateral, solid portions, and a smaller median part. In the lateral rudiments a narrow lumen appears in segmental fashion. The outer wall represents somatopleure, but the inner forms not only the muscular, but the epithelial layer of the mid-gut. The central, unpaired, and inconspicuous portion serves merely to unite the paired endodermic rudiments of the mid-gut, except at the anterior end where it forms by broadening the greater part of the epithelial wall. In the yolk, which exhibits a sort of segmentation, the “yolk-cells” long persist, but are finally absorbed.

**Nutrient Food-Material of Bees.†**—Herr A. von Planta has made an examination of the food provided by the “nurses” for the larvæ of bees; he finds that for queens 69·38 per cent., for drones 72·75 per cent., and for workers 71·63 per cent. is water. The chemical composition of the remaining solids is shown in the accompanying table:—

	Queens.	Drones (1–4 days).	Drones (after 4 days).	Workers.
Nitrogenous materials..	45·14	55·91	31·67	51·21
Fatty .. .. .	13·55	11·90	4·74	6·84
Glucose .. .. .	20·39	9·57	38·49	27·65
Ashes .. .. .	4·06	..	2·02	..

As the food varies in composition the author is inclined to reject the theory that we have here to do with a secretion analogous to that of milk, and to support the theory of Schönfeld that the food comes from

\* Biol. Centralbl., viii. (1888) pp. 449–52.

† Notice by E. Bourquelot in Arch. Zool. Expér. et Gén., vi. (1888) pp. xiii.–xvi. See Zeitschr. f. Phys. Chem., xii. p. 327.

the stomach, and that its composition and degree of digestion are varied by the bee according to the age and sex of the larva.

**Odoriferous Glands of Blaps.\***—Prof. G. Gilson thus sums up the principal results of his researches on the odoriferous glands of *Blaps mortisaga* and several other species: There exists in *Blaps mortisaga* a well-developed odoriferous apparatus formed by cells, the so-called unicellular cutaneous glands. These cells are grouped so as to form lobes resembling glandular tubes, but they are specialized in having an excretory tube connecting each cell with the exterior. Each cell possesses a secreting apparatus consisting of four parts—a radial vesicle, a central ampulla, a thin excretory tube, and a tube-sheath analogous in structure to the radial vesicle. The solid portions of these parts are continuous with the reticulum of the protoplasm. The inner rays of the vesicle and of the sheath are regular, strengthened, radial trabeculæ of protoplasm. The membrane of the vesicle, and those of the sheath, tube, and ampulla are similar in structure to the cellular and nuclear membranes; they are productions of the protoplasm. The reticulum does not necessarily radiate from the nucleus of the cell; many of the trabeculæ radiate from other protoplasmic structures such as the radial vesicle, the sheath, and the excretory tube itself.

**Alimentary Canal in Metamorphosis.†**—Dr. D. Casagrande reports the results of his researches on the transformation exhibited by the alimentary canal of Lepidoptera in the metamorphosis from the larval to the adult state. His research was based on the silkworm. The general conclusion of his investigation of this important point is as follows:—The epithelium of the cesophagus and of the hind-gut of the perfect insect is derived from the epithelium of the mid-gut; in such a case the cesophageal and hind-gut epithelium in the adult insect cannot be regarded as ectodermic in origin as they are in the larva, but must be endodermic, arising as they do from the mid-gut.

**Nerve-terminations in Lepidoptera.‡**—M. J. Chatin has studied the nerve-terminations in Lepidoptera. In the proboscis below the skin they form a rich network of fine filaments and cells. From multipolar cells fine prolongations proceed outwards and are lost between the elements of the hypodermis. In many cases (*Sphinx*, &c.) the nerve-filaments were observed to dilate into a fusiform cell and then to enter into relations with a tactile cell of the hypodermis. Soft cones with similar innervation were observed on various parts of the proboscis, on the labial palps, &c.

In a further paper the author describes the nerve-terminations on the antennæ of *Tinea tapezella*. Two types occur—tactile hairs and long soft cones. With these, nerve-filaments are associated as above described.

**Basal Spot on Palps of Butterflies.§**—Herr E. Reuter states that in all the species of Butterflies (between two and three hundred) which he has examined there is at the base of the inner surface of the palps a naked spot which can always be easily seen. He consequently regards it as typical of the order Lepidoptera. It is generally well defined and ordinarily occupies the basal half of the first joint of the palp. The

\* La Cellule, v. (1888) pp. 1–21 (1 pl.).

† Bull. Soc. Entom. Ital., xix. (1887, pub. 1888) pp. 323–33 (3 pls.).

‡ Boll. Soc. Entom. Ital., xix. (1887) pp. 183 and 367. Bull. Soc. Philom. Paris, x. and xi. (1887) p. 145.

§ Zool. Anzeig., xi. (1888) pp. 500–3.

rings or furrows discovered by Landois are always present, though often indistinct or incomplete. When present they ordinarily occupy the greater part of the basal spot, and are more or less parallel. They are best developed on the part of the surface which, in the natural position of the palps, is directed upwards and inwards; it is this part which is most commonly pressed against the basal part of the proboscis, which is provided with a raised ridge.

In addition to these rings there are peculiar forms of hairs which do not seem to have ever yet been described. They are conical in form, chitinous, and surrounded at their base by a circular membrane; they are all connected with nerve-fibres, on which, just before they enter the cone, a ganglionic swelling can be seen. There are several hundreds of these cones, and, in addition to them, there are immense numbers of similar, but much smaller, conical bodies. In the Microlepidoptera there are sometimes also pits or pores, and sometimes these pits are alone present.

There can be no doubt that we have here to do with specific sensory organs, but what is the special sense we do not yet know. The author is inclined to think that it is of an olfactory nature. The cones exhibit the greatest variability and highest grade of development in the Rhopalocera, and their variations may be of use in the definition of families and genera. In the Butterflies proper the organ in question is always much larger and better developed in the male than in the female.

**Development of *Musca*.**\*—Prof. O. Bütschli gives an account of some observations by two of his pupils, Herren C. Maurice and H. Debus, on the development of the fly; it is, unfortunately, so written as to be unintelligible without reference to the figures by which it is illustrated. It would appear that *Musca* differs from other Metazoa with a similar mode of development of the mesoderm in that the extended gastrula-invagination is only differentiated into endoderm and mesoderm at its hinder end, and that the greater part corresponds only to the part of the endoderm which forms the cœlomic diverticula.

**Larva of *Sarcophila Wohlfartii* in Gum of Man.**†—Prof. E. Brandt relates a case of the presence of the larva of *Sarcophila Wohlfartii* in the gums of human patients. This viviparous creature is very active in the hot part of the day (from 1 p.m. to 4 p.m.), and attacks men sleeping in the open, and unguilates, but does not go into rooms or stalls. The gum of the patient was inflamed and swollen, but all troubles ceased as soon as the larvæ were pressed out. The larvæ found in this case were in the second stage of development, that marked by the possession of only two oral hooks, two stigmatic clefts on the hinder stigma-plates, and by the peculiar arrangement of the spines which has been figured by Portschinsky in his monograph.

**Brain of *Somomya*.**‡—Dr. G. Cuccati has investigated the minute structure of the brain of *Somomya erythrocephala*.

The otic-ophthalmic bundle, the "corpo foreato" in the brain, the antennary lobes, the "olfactory glomeruli," the otic ganglia, the cerebral peduncles, &c., are referred to with appalling exactness, and the results are compared with the author's previous investigation of the supra-œsophageal ganglia of Orthoptera.

\* Morphol. Jahrb., xiv. (1888) pp. 170-4 (2 figs).

† Zool. Anzeig., xi. (1888) pp. 560-1.

‡ Boll. Soc. Entom. Ital., xix. (1887, pub. 1888) pp. 286-8.

## β. Myriopoda.

**Phosphorescence in Myriopoda.**—M. J. Gazagnaire,\* in face of the discussion between Professors Dubois and Macé on phosphorescence in Myriopods, relates some observations which he has made himself. He found that, in *Oryx barbarica*, the whole of the ventral surface of the body was luminous; pressure alone was sufficient to give rise to the luminosity; it was either total or localized in one or more rings. The light is seen on the sternal plates, and on the anterior and posterior plates of the episternum; with the aid of a good hand-glass it is possible to detect the presence of a number of cutaneous pores on these plates. On contact these pores secrete a yellowish viscous substance of a peculiar odour; in contact with air it dries rapidly; it is insoluble in alcohol, and of an acid reaction. This substance is very phosphorescent, and the light which it emits is intense, persistent, and bluish-green. Owing to its viscosity it attaches itself to objects in contact with it, and makes them luminous for a short time. In fact, this photogenic material behaves like the phosphorus of a match on moist fingers. The author thinks that we have here to do with a cutaneous secretion which contains the photogenic matter, and he believes that in other species the facts are the same, and that the photogenic body is always secreted by glandular organs ventral in position.

M. R. Blanchard † states that he collected a specimen of this luminous Myriopod; he found the phosphorescent matter attach itself to his fingers, and there show brightly for four or five minutes. He rubbed his fingers on his clothes, and he found that the rubbed parts also became luminous, and presented luminous waves absolutely identical with those of match-phosphorus; they disappeared gradually. It seems to him evident that the luminous substance is distributed over the whole length of the body, or at least over its greater part, and that it is a liquid or mucilaginous substance which is easily spread by rubbing.

## δ. Arachnida.

**Relations of Structure and Function to Colour Changes in Spiders.**‡—The Rev. H. C. McCook has some suggestive notes on the relations of structure and function to colour changes in spiders. He points out that as young spiders advance in age their colour deepens; this must be explained by gradual hardening of the tissues making them more opaque, since, up to this period, no food has been taken. It is not until sedentary spiderlings have established themselves upon their own webs that the characteristic colours of the species begin to appear with any positive degree of distinctness. Moulting seems to produce changes in colour-patterns of a very decided kind in some species; some organic change is probably the cause of this phenomenon. Advanced age, as a rule, makes the colours darker. In gravid females the changes of colour are often very decided; the lighter coloration is probably due to the skin being disturbed and more transparent. The action of the muscles on the skin and chitinous shell or walls, serves to compel certain aggregations of pigment along the lines of use.

With regard to the relation of environment and habit to colour

\* Bull. Soc. Zool. France, xiii. (1888) pp. 182-6.

† Tom. cit., p. 186.

‡ Proc. Acad. Sci. Philad., 1888, pp. 172-6.

changes, Dr. M'Cook observed that spiders that live on plants as a rule have colours that are harmonious with the prevailing greens and yellows. Spiders that nest in stables, houses, on fences, &c., ordinarily have dusky colours, harmonious with the environment. Ground spiders generally have colours of neutral greys that blend well with the soil, rocks, or stalks of grass, especially when the last are somewhat dry.

On the whole, we may conclude that many spiders that appear to be more exposed to enemies by reason of bright colours or greater size have developed, or at least possess special variations in industry and habits that in some degree are protective. But there are a number of apparent exceptions which require more careful study before any general deduction can be warranted.

**Development of Generative Organs in Arachnida.\*** — Herr V. Faussek makes a welcome contribution to our scanty knowledge of the development of the generative organs in Arachnida, in an investigation based upon *Phalangium (cornutum?)*. When the segmentation of the ventral plate begins, the rudiments of the reproductive organs lie as a group of cells at the abdominal end of the embryo, protruding somewhat into the segmentation cavity. The boundaries of the closely packed cells are hardly distinguishable, the nuclei are large, the chromatin granules isolated.

When nerve-cord, &c., are differentiated, the rudiment still lies as before, inclosed in the mesoderm at the hind end of the nerve-cord. It lies between the two mesoderm plates, in the future coelom. In the liberated young, the rudiment is still an unpaired mass of cells, and soon it becomes a differentiated organ. Only the female organ was traced.

As to the origin of the germinal cells no quite certain answer can yet be given. It seems very probable, however, that they arise directly from the yolk-cells, contemporaneously with the appearance of the germinal streak, and quite independent of the somatic cells of the blastoderm. If this is so, it is interesting as another illustration of the very early differentiation of the reproductive elements.

**Blood of Spiders.†**—M. V. Wagner has investigated the blood of spiders. It consists of a colourless liquid plasma in which float corpuscles or blood-cells. Blood freshly drawn from an adult spider contains four kinds of cells, of which only two, the amoeboid and the coloured, are constant. These two forms have some properties in common, and have certain affinities of structure, but they differ widely in regard to other properties, and in their mode of multiplication. They also differ in origin, the former being mesodermic, the latter, endodermic. The other two kinds of cells are only provisional stages of the constant forms, and may be considered as the results of multiplication. The size of the blood-cells increases with the age of the animal. In an adult the proportion of the different forms of corpuscles, in the various regions of the body, is strictly defined. During growth the proportion varies constantly (in different stages), and periodically (in connection with the skin-casting). The proportion is altered periodically by the sudden appearance of the spherical forms whose number increases to excess after the casting of the skin. As these spheres represent the stage of multiplication in the constant forms, they indicate the intensity of the

\* Biol. Centralbl., viii. (1888) pp. 359-63.

† Arch. Slav. Biol., iv. (1888) pp. 297-336.

processes in these cells at that time. This intensity may be explained, to some extent, by the slowness of the circulation during and immediately after the moulting. As only two forms are constant, it must obviously be those two which, from this point of view, are of most importance. The difference of reaction between the amœboid and the coloured cells, and the affinity between the amœboid cells and the leucocytes of higher animals, enable us to determine the rôle of these elements, up to a certain point, with much probability, if not certainty.

#### e. Crustacea.

**Castration of the Cray-fish.\***—M. G. Stamati remarks that no one has yet attempted to castrate any animals except Mammals and Birds. He failed when he tried to inject by the male deferent ducts an aqueous solution of acetic acid, or to directly extirpate the gonad and duct; the best way is to remove the deferent duct by an incision in the membrane which separates the cephalothorax from the abdomen, by the insertion of very fine forceps. The animal must then be put into a very small amount of water, sufficient for breathing purposes, but not sufficient to enter the wound, which, after a time, heals. He promises to communicate what the results of this experiment are, but time is necessary for the observation of them.

**Digestion in Cray-fishes.†**—M. G. Stamati has made some observations on digestion in cray-fishes by the aid of gastric fistulæ. The fluid of the stomach produces almost instantaneously a permanent emulsion and saponification of a neutral oil; it converts cane-sugar into inverted sugar, changes uncooked starch into glucose, and forms peptones from proteid foods. The gastric juice, which is secreted continuously, was found to be formed by the so-called liver, which is a gland of double function, for, in addition to giving rise to the changes just enumerated, the gland contains glycogen, the quantity present of which varies with the food. Lecithin and cholesterin can be obtained from this gland. There is a colouring matter in the organ, but it cannot be said to be analogous to the biliary secretions of Mammals. Like some preceding writers, M. Stamati proposes to call this organ of double function a hepatopancreas.

**Innervation of Crabs' Claws.‡**—Prof. W. Biedermann, in his twenty-first communication on the physiology of nerve and muscle, reports the results of his investigation of the innervation of crabs' claws. In the first place he discusses the changes in form observed in the two antagonistic muscles under the influence of electrical stimulation of the nerves supplying the claws. In the second place, he describes the electromotor activities in the closing muscles on tetanic stimulation of the associated nerves. "All the observed consequences of indirect stimulation of the claw muscles of the crab seem to find their simplest explanation in the supposition that each of the two muscles is provided with two functionally distinct, inhibiting and stimulating nerves." "These nerves, which, on the theory maintained by Löwit and Gaskell, may be described as 'Assimilirungs- and Dissimilirungsnerven,' induce by their excitation opposite conditions in the muscle substance, which

\* Bull. Soc. Zool. France, xiii. (1888) pp. 188-9.

† Ibid., pp. 146-51.

‡ SB. K. Akad. Wiss. Wien, xevii. (1888) pp. 49-82 (4 pls.).

find expression on the one hand in opposed changes of form, and on the other in contrary electromotor activities." "The mutual relation of the two processes simultaneously set up in the muscle, may have a different import in relation to the mechanical effect of stimulation, from that exhibited in relation to the electromotor activities." The author points out that Fano's experiments on the cardiac muscle of the tortoise also showed an imperfect agreement between the changes of form and the simultaneous electric phenomena. Finally, it is to be noted, as Gaskell's researches have shown, that in several respects there are analogies between the innervation conditions of the cardiac muscle of Vertebrates and those of the claw muscles of crabs, as especially exhibited in the galvanic consequences of stimulation.

'Challenger' Crustacea *Macrura*.\*—Mr. C. Spence Bate has completed his investigations into the 2000 specimens of macrurous Crustacea which were collected during the voyage of H.M.S. 'Challenger.' In addition to the detailed descriptions of this vast quantity of material, the author gives an interesting introduction in which he treats of the morphology of the group. With slight modifications, the classification proposed in 1883 by Prof. Huxley is accepted, the group being divided into the Trichobranchiata, Dendrobranchiata (= Penæidea, Dana), Phyllobranchiata, and Ammobranchiata.

Structure of *Asellus*.†—Herr B. Rosenstadt has investigated the structure of *Asellus aquaticus* and related Isopods, and notes the points in which his results differ from those of Sars.

(1) *Vascular system*. The heart begins at the boundary of the fourth and fifth segment, and extends into the reduced abdominal segments. The two pairs of venous ostia are symmetrically disposed. The aorta becomes smaller till it reaches the cardiac portion of the fore-gut, where it expands into a vesicular enlargement, and gives off two ophthalmics, a peri-oesophageal ring, and branches to antennæ and brain. From the heart there also rise two lateral arteries, three pairs of thoracics, and a fourth pair to the reduced abdomen. The peri-oesophageal ring is continued into a ventral artery, connected by seven pairs of vessels with the thoracics. There are no branchio-pericardial vessels. On the dorsal surface of the heart of *Asellus* embryos are two delicate strands, also seen in *Idotea* and *Jaera*, and regarded by Claus as sympathetic nerves. The peculiarities of *Jaera* are discussed.

(2) *The Nervous system of Asellus* and other Isopods is then described, but the results are chiefly corroboratory of Brandt and other previous investigators. (3) In regard to the *alimentary system*, two pear-shaped glandular sacs on the posterior end of the upper lip of *Asellus*, and similar glands are described. The structure of the gut is briefly discussed. In the mid-gut gland only epithelial cells of different sizes were to be seen. Weber's hepatic cells and ferment-cells are large and small stages of the same kind of cells.

(4) *Excretory system*. At the base of the outer antennæ lies a rudimentary antennary gland. Coiled canals by the side of the stomach contained urates, and were seen to open by a duct on the base of the second maxillæ. This gland, seen in six genera, seems to be really a shell-gland, such as Claus has observed in *Apsudes*. (5) *Reproductive*

\* 'Challenger' Reports, lii. (1888) xc. and 942 pp. (157 pls.).

† Biol. Centralbl., viii. (1888) pp. 452-62.

*system.* Schöbl's observations in regard to the changes in the females after impregnation are confirmed. After the moulting the female aperture is lost, and a brood-chamber develops. After young have been borne twice, the female moults and regains its apertures.

**Sexual Dimorphism in Amphipoda.\***—Prof. T. Barrois finds that *Mæra integrimana* Hiller is the female of *M. scissimana* Costa, and that *M. Donatoi* of Hiller is, similarly, not a good species, but the female of *M. grossimana* Montagu.

**Development of Gammarus.†**—Dr. Sophie Pereyaslawzewa communicates the first of a series of researches on the development of Amphipods. The present memoir deals with *Gammarus pœcilurus* Rthk.

The living egg is first described in its initial and subsequent stages. The author then briefly discusses the modifications exhibited previous to segmentation. The segmentation itself and the establishment of the layers are described. The derivation of the organs of the three layers is followed in detail. Amœboid movements were observed in the embryonic cells, especially in those of the endoderm, and this not only in *Gammarus*, but also in *Caprella* and *Orchestia*. The author reserves general deductions until a larger number of forms have been investigated by herself and her students. An appreciation of the results will then be more readily made.

**European Daphnidæ.‡**—Dr. E. Eylmann gives a valuable systematic account of European Daphnidæ. After giving a diagnosis of the family, he distinguishes the five genera—*Daphnia*, *Simocephalus*, *Scapholeberis*, *Ceriodaphnia*, and *Moina*. The (forty-seven) species are then diagnosed in detail. *Daphnia curvirostris* is noted as a new species. Tables for specific identification, and one showing the distribution, increase the value of this systematic monograph.

**Orchestia.§**—M. E. Chevreux has a note on the presence of *Orchestia Chevreuxi* at Teneriffe, and a description of the male of this species. With regard to the locomotor activity of this genus, he observed that, in *O. littorea*, the posterior part of the abdomen was always folded under the body when the creature was moving on a horizontal plane, and that the last five pairs of thoracic limbs were alone used. It was evident that the longer they were the more easily could the creature move, so that we may ascribe the difficulty of capturing *O. Chevreuxi* to the great length of its appendages. In an earlier essay || the author has some remarks on the adaptation of Amphipods to a terrestrial mode of life.

**Amœbocytes of Crustacea.¶**—Dr. G. Cattaneo has a preliminary notice of the amœbocytes of Crustacea, in which he discusses the structure and spontaneous modifications of the amœboid cells of *Carcinus*, their histological phenomena, and their variations in different surroundings and under the influence of various reagents. Prof. F. Leydig \*\* calls attention to his description of similar bodies in his 'Naturgeschichte der Daphniden,' published in 1860. There, too, are to be found some observations on the corpuscles found in the blood and other tissues of sick caterpillars.

\* Bull. Soc. Zool. France, xiii, pp. 57-9.

† Bull. Soc. Nat. Moscou, 1888, pp. 183-219 (4 pls.).

‡ Ber. Nat. Gesell. Freiburg, ii. (1887) pp. 61-148 (5 pls.).

§ Bull. Soc. Zool. France, xiii. (1888) pp. 92-6.

¶ Zool. Anzeig., xi. (1888) pp. 452-5.

|| Tom. cit., pp. 59-66.

\*\* Tom. cit., pp. 515-6.

## Vermes.

## a. Annelida.

**External Morphology of Hirudinea.\***—Dr. S. Apáthy has made a close study of the external body-form of Leeches. The typical somites are found in the mid-body, and consist of a number of rings, constant within the limits of the genus, and having, either in part or all, special distinguishing marks. Among the Rhynchobdellidæ *Branchellion* and *Clepsine* have three rings, *Calliobdella*, *Ichthyobdella*, and *Pontobdella* six, *Piscicola* twelve; the Gnathobdellidæ have five rings. All the rings have tactile goblets, of which *Piscicola* has eighteen in a transverse row; there are also one internal and one external paramedian, one external and one internal paramarginal, and one marginal goblet on the boundary of the rings. These goblets contain a group of specific epithelial cells, which always carry a tactile seta each. Further distinguishing marks are afforded by the plexiform superficial pigment which forms dark transverse bands, and by the position of the nephridiopores. The special marks of the several rings are regularly repeated in each somite in which the ring is present, and the absence of these marks indicates the absence of certain rings.

All the somites of the other parts of the body are only modifications of the typical somites of the mid-body. These modifications are seen in the more or less well-marked character of the rings, in the appearance of certain superficial foldings of the skin, and in the smoothing out of foldings which are found in the somites of the mid-body; but the most marked character is the shortening and reduction of the somite, due to change in or loss of function.

The first form of shortening is the simple reduction in length of the somite, without any fusion of the ring. In the mid-body the somites are all of much the same length, except where secondary extension of certain parts of the enteron combined with a thickening of the body has produced a certain increase in length of the somite. It is to be noted, however, that, in all genera, there is a regular increase in length of the somite from the clitellum to the end of the body, and from the hinder boundary of the mid-body to the sucking disc.

The second form of shortening is the fusion of certain rings, ordinarily belonging to the same third of a somite, with one another, so that in some genera where the typical somite consists of six rings, there are only three independent rings. It is rare for rings of different thirds to become fused by the secondary adaptation of tegumentary folds. When a somite of the Rhynchobdellidæ is reduced the reduction is first seen in the hinder ring; if the reduction goes further the second ring is affected, and beyond this reduction never goes.

This law of reduction is due to the relation of the general function of the typical somite to the three thirds of the internal somite. As soon as a change of function of a given part of the body causes certain organs to become superfluous, that third of the internal somite with which that function or group of functions was connected disappears also; the remaining third or thirds are developed at the cost of what has disappeared. The hinder third contains no organs which are necessary for absolute existence, and so it is the first to disappear; on the other hand,

\* Mittheil. Zool. Stat. Neapel, viii. (1888) pp. 153-232 (2 pls.).

the first third contains the most important, and so it is always retained. Although this disappearance must have been quite gradual phylogenetically, yet in ontogeny the result alone is seen, the reduced somite being reduced in the embryo. On the other hand, all the shortenings, reductions, and fusions of the rings, and the appearance characteristic of the species or bearing on their sexual life, are put off to a late embryonic stage, or, more frequently, till post-embryonic life. The Gnathobdellidæ follow the same laws as the Rhynchobdellidæ.

The author makes some critical remarks on Mr. Whitman's explanation of the external morphology of the Hirudinea.

If we sum up what is known as to the external morphology of these forms, we may say that the Hirudinea have an elongated body which, as a rule, tapers at both ends; it is smooth externally and is provided with regularly distributed folds of the integument; it is always distinctly ringed, and is, in cross section, rounded or horizontally oval; it only becomes flattened secondarily, and its length is, proximately, due to the number of rings found in each somite. The body is always made up of thirty-three distinct somites, each of which possesses a ganglion consisting of six ganglionic capsules, which become more closely approximated to one another at either end than elsewhere, without undergoing any greater modifications. The somites shorten regularly towards either end of the body, and at the same time become more or less reduced. The number of non-reduced somites is characteristic of the genus, but the extent and mode of reduction are generally specific characters only; they have no direct connection with the phylogeny of the whole order.

The whole body may be divided into six functionally different regions, all of which, with the exception of the anal, consist of six somites each; they are the cephalic or suckorial region, the clitellar region, the region of the fore- and that of the hind-gut, the anal region, and that of the attaching disc. The cephalic region has, in the interest of a semi-parasitic mode of life, been more or less converted into a sucker; this is a thickening of the end of the body; the apparently secondary anus is in the form of a transverse cleft which, at a late period, breaks through the skin in the middle line of the back. The final region has a disc, the size and form of which is in direct connection with the grade of parasitism, and which, in non-parasitic forms, is chiefly used as a locomotor organ. The clitellum occupies somites 10-12, and is more or less secondarily modified, its form varying in different families; the male generative orifice is on the eleventh and the female on the twelfth somite. The relative size of the mid-body is an adaptation to the quantity of food which the genus has to obtain; its median segments, or somites 14-23, are typical of genus and species.

In all Hirudinea there is a highly developed tactile sense, and eighteen longitudinal rows of tactile goblets; in some genera the marginal line is distinguished by larger goblets, and so presents a distinct homology to the lateral lines of the Capitellidæ. Eyes, which in the more highly developed genera perceive light, colour, and probably even form, are best developed in the fresh-water forms.

Specific glands are present in the form of special chitin-glands which are used to form the cocoon, and, when no cocoon is made, as in some species of *Clepsine*, they form an embryonic attaching gland.

The author believes that the Hirudinea form an order of Annulata parallel to the Chætopoda. In later times there appears to be a tendency

to revert to a free, carnivorous life, which, starting from *Pontobdella* and *Branchellion*, culminates in *Aulostoma* and *Hæmadipsa*. The most parasitic forms are all marine, emancipation from the parasitic mode of life having gone on in fresh water; the most parasitic are by far the richest in individuals, but very poor in species. *Ichthyobdella* appears to be the link between the free Annulate ancestor and the Selachian parasites *Pontobdella* and *Branchellion*. *Cylicobdella* leads through *Lumbricobdella* to *Nepheleis*, and by another line to *Hirudo*, and *Hæmadipsa*, and to *Aulostoma*. *Piscicola* leads to *Clepsine*. The author appears to have examined a large number of species of Leeches, some of which seem to be new, but are not here diagnosed.

**Nerve-endings in the Leech.\***—Herr J. F. Heymann has investigated the nerve-endings in the unstriped muscle-fibres of the leech. His results differ from those of previous investigators. Thus, besides the ventral visceral nerve there are two quite similar in a dorsal position. The main nerve-plexus lies between the circular and longitudinal sheath of muscles. This is known to be connected with a peripheral or inter-muscular, but what the exact endings were has been doubtful. According to the author distinct terminal plates may occur on the terminal fibrils, or these may be absent. Sometimes one muscle-fibre was seen to have four associated terminal plates. In the lateral contractile vessels the author maintains the existence of two muscle-layers, circular and longitudinal, but formed from the same fibres. Their innervation and the termination of the fibrils in ovoid knots are described. Finally, Herr Heymann describes how the lateral nerves from the ventral chain are associated with the voluntary muscles. Each twig ends in a granular plate in and not on the contractile sheath of the muscle-fibre.

**Creeping Movements of Earthworm.†**—In the course of experiments on earthworms Herr B. Friedländer was led to make some interesting observations in regard to their creeping movements. If some of the posterior segments of an earthworm be cut off, the animal acts quite normally; it bores at once into the earth. But if some of the anterior segments be cut off, the worm begins at once to move and twist violently, and creeps about for a time. It soon becomes quiet, however, and may lie on damp earth for weeks without moving. On the slightest irritation it awakes out of its passivity, moves or creeps about for a little, but soon relapses into its former lethargy. Still more interesting is the following experiment. A ventral lateral incision was made about the middle of a worm, and a small portion of the nerve-cord removed. Herr Friedländer found, to his astonishment, that worms which had been so treated crept exactly like normal animals. In explanation, he discusses the possibility of the stimulus being transmitted directly from muscle to muscle, but gives reasons against the probability of this. He is inclined to believe that the pull is transmitted in a purely mechanical way through the enervated region, and that the rest is reflex. He supposes that "a longitudinal extension sets up a longitudinal contraction as a reflex movement, and thus the locomotion of the normal and of the injured worm are explicable in one and the same way." His facts, he submits, at least remain.

\* Arch. Anat. Physiol. (Physiol. Abth.), 1888, pp. 556-60.

† Biol. Centralbl., viii. (1888) pp. 363-6.

**Excretory Organs of *Criodrilus*.**\*—Dr. R. S. Bergh describes the ontogeny of the excretory organs in *Criodrilus*. They arise entirely in the somatic muscle-plate, without any relation to or connection with the rudiments of the adjacent segments. Funnel, coil, and terminal portions are differentiated from a common rudiment. The funnel is formed chiefly from a cellular material, derived from the divisions of the funnel cell, and its cavity arises from the subsequent separation of the cells. The lumen of the coiled portion arises from fusion by vacuoles appearing within the cells. The terminal portion bores in between the epidermic cells, and breaking through forms an external aperture.

After a chapter devoted to a critical review of the results reached by Kowalewsky, Kleinenberg, Whitman, Hatschek, Vejdoovsky, and Wilson, the author passes to describe the pair of provisional excretory organs which are present in *Criodrilus* embryos before the segmental organs are established. The pair of primitive kidneys consist of perforated cells, and form white strands, very readily seen, though hitherto overlooked. They have their blind beginning beside the œsophagus, and in the head-cavity lie close to the epithelium of the gut. From their origin they extend backwards, arching towards the back, but bend again ventrally, and open to the exterior on the side of the body about the middle of its length.

#### β. Nemathelminthes.

**Abnormal Ova of *Ascaris megalcephala*.**†—M. A. Lameere has found two female specimens of *Ascaris megalcephala*, in which the ova have retained the club-shaped form which they ordinarily have only in the upper part of the oviduct. Most of these eggs were non-fecundated.

The external hyaline layer becomes thickened at the slender end of the cell; in the neighbouring region the protoplasm is clearer than in the rest of the egg; on each side of the handle of the club there is a constriction which corresponds to a circumference which bounds a surface that is distinctly folded. This region clearly corresponds to the part which constitutes the primitive form of the oviducal eggs. It is in that part that, in the first period of maturation, when the eggs begin to be gradually ellipsoidal in form, there is a groove in which the polar disc is differentiated. The author believes that the germinal vesicle tends to advance in a direction opposite to the pole of impregnation.

**Heterodera Schachtii.**‡—M. Willot points out that, like Dr. Steubell, he has recommended the use of sea-salt as a means of killing this nematode. Curiously enough their objects were different, for M. Willot was seeking what he calls a nematocide, while the German naturalist was trying to keep the worms alive, and did not see the bearings of his observations on economic husbandry.

#### γ. Platyhelminthes.

**General Sketch of the Trematoda.**§—Under this title Mr. W. E. Hoyle has reprinted, with additions, his article on the Trematoda from the ninth edition of the 'Encyclopædia Britannica.' The ordinary historical

\* Arbeit. Zool.-Zoot. Inst. Würzburg, viii. (1888) pp. 223-48 (2 pls.).

† Bull. Acad. R. Sci. Belg., lviii. (1888) pp. 980-4 (1 pl.).

‡ Comptes Rendus, cvii. (1888) pp. 507-9.

§ Svo, Edinburgh, 1888, 19 pp., 4 pls. of woodcuts.

introduction is followed by an account of the anatomy and life-history of the common liver-fluke, and that by a few words on pathological and economic relations. A sketch is given of the generally received systematic arrangement of the group; in discussing the phylogenetic relations of the Trematoda attention is called to Fewkes's description of a marine cercaria which had a tail distinctly annelid in character, with bundles of bristles disposed at intervals along it.

*Aspidogaster conchicola*. \*—Herr A. Voeltzkow has investigated the structure and life-history of the Trematode *Aspidogaster conchicola* discovered by Von Baer in the fresh-water mussel. His general results are as follows:—The parasite occurs in the pericardium, the kidney, and the red-brown organ of *Anodonta* and *Unio*. It lived four to five weeks in a weak salt solution. The alimentary system consists of a protrusible pharynx with salivary glands, and a sac-shaped gut with amœboid epithelial cells. The nervous system is well developed. The sucker includes tasting organs and mucus-glands. The water-vascular system consists of an expelling tube with a terminal bladder and foramen and of the ciliated vessels throughout the body. The male side of the reproductive system consists of testis, vas deferens, seminal vesicle, prostate, penis sheath, and penis. The female system exhibits an ovary, a "fallopian tube," oviduct and vulva, and also a triangular "ootyp" or junction of fallopian tube, oviduct. and duct of the "yolk-receptacle." There are two pairs of yolk-glands, two yolk-ducts ending in a yolk-vesicle, which opens into the oviduct. Hitherto undescribed is a special *receptaculum vitelli* opening into the ootyp. There is no internal fertilization.

The differentiation of the perfect sucker from the embryonic structure is accomplished by the development of transverse, median longitudinal, and two external ridges. The ovum undergoes total segmentation. As in other Trematodes an insheathing membrane is formed from cap-shaped cells. The water-vascular system arises from the primitive secreting organ. The essential reproductive organs are mesodermic; penis, vulva, receptaculum vitelli, and the associated ducts are ectodermic in origin. The young animals enter the gut, pass their early stages there, and pass through the gut, where it traverses the red-brown organ and pericardium. In an appended paper, Herr Voeltzkow discusses *A. limacoides*, a new species described by Diesing.

*Holostomum*. †—Herr G. Brandes has a preliminary notice of his researches on the genus *Holostomum*. A comprehension of its anatomy and general form is not easy, as it has been reported to exhibit very different arrangements from those generally seen in Trematodes. Linstow, for example, has spoken of the dorsal as the ventral side. The author explains the morphology of *Holostomum* by reference to the simpler characters presented by *Hemistomum*. The former may be shown to exhibit the following characters:—The ovary lies in the anterior third of the hind-body, and the paired testes are a little way behind it. The oviduct, after some coils above the first testis, gives off the canal of Laurer to the dorsal surface, then passes between the two testes, becomes united with the unpaired yolk-duct, passes into the shell-gland, and becomes a uterus. This extends as far as the anterior pole of the hind-

\* Arbeit. Zool.-Zoot. Inst. Würzburg, viii. (1888) pp. 249-292 (6 pls.).

† Zool. Anzeig., xi. (1888) pp. 424-6.

body, then bends round and extends along the ventral surface of the animal as far as the hinder pole of the body, where it ends in the generative cone. At the base of this cone the efferent duct of the vesicula seminalis opens into the uterus; the yolk-glands, which extend over the whole ventral surface of the worm, pass the yolk into an unpaired duct by transverse ducts which arise at the level of the shell-gland. The excretory pore is found on the dorsal surface, and almost at the extreme end of the animal.

*Tænia cucumerina* in Man.\*—Prof. E. Brandt gives an account of two cases of *Tænia cucumerina* in Man. From one patient forty-eight specimens, which varied in length from ten to thirty-five centimetres, were expelled; this large number had set up enteric irritation and disturbances of the nervous system. The patient, a peasant boy of fourteen, used to play with and caress a mastiff, which had lately become offensive from the "lice" with which it was affected. Prof. Brandt has no doubt that the "louse" was *Trichodectes*. In the second case thirty examples were expelled after treatment, all with heads; the patient was in the habit of playing with a King Charles's spaniel which was troubled with *Trichodectes*.

*Tænia saginata*.†—Dr. F. Tuckerman has a supplementary note † on this tape-worm, based on a second, even more remarkable, specimen. The worm appears to have had a total length of 8·253 metres, but the number of joints (727) is considerably below the number allowed by most authorities to a much smaller worm. The smallest segment was 1 mm. broad and 2 mm. long; the largest 4·5 mm. across, with a length of 31 mm. Several of the joints were 2 mm. thick. Supernumerary joints were not infrequent. One sexually mature segment is so bent as to form a right angle.

### 8. Incertæ Sedis.

Contractile Vesicle of Rotifers.§—M. L. C. Cosmovici thinks that the characters of the contractile vesicle of Rotifers have hitherto been misunderstood. He considers that, anatomically, it is nothing but a cloaca. He thinks its function is to drive out the water which has passed into a digestive tube, and not to expel the perivisceral fluid.

*Haplodiscus piger*.||—Mr. W. F. R. Weldon gives an account of the remarkable new pelagic organism discovered by himself in the Bahamas. In its mode of progression and superficial likeness to a protozoon it has a strong resemblance to *Leptodiscus medusoides* of R. Hertwig.

The body-wall is formed dorsally of two, and ventrally of three layers; dorsally, the cuticle is an apparently structureless or very finely granular layer, while ventrally there is, beneath the layer which is like the dorsal cuticle, an inner layer which appears in section as a very narrow transversely striated band. A muscular layer seems to be present on the ventral surface only; in the region of the ductus ejaculatorius some of the fibres pass inwards to form part of the sheath of that organ. Beneath the layer of transverse fibres there is a longitudinal

\* Zool. Anzeig., xi. (1888) pp. 481-4.

† Ibid., pp. 473-5.

‡ See this Journal, 1888, p. 427, where by an error the account, which is by Dr. Tuckerman, is ascribed to Dr. J. G. Stanton, from whom the specimen was received.

§ Bull. Soc. Zool. France, xiii. (1888) pp. 167-9.

|| Quart. Journ. Micr. Sci., xxix. (1888) pp. 1-8 (1 pl.).

layer which appears to be much less important. A protoplasmic tunic, perforated only by the ductus ejaculatorius, forms the innermost layer of the body-wall; it consists of an irregular layer of granular protoplasm, in which nuclei are imbedded at frequent intervals, but which does not show any trace of division into distinct cells. From its inner wall numerous processes are given off which anastomose with one another in the cavity of the body, and so form a reticulum which is continuous with or forms an investment for the remaining organs of the animal. A number of mucous glands which open to the exterior are imbedded in the tunic.

The brain is transversely elongated, and is imbedded in the tissue at the anterior end of the body; it is composed of a mass of fibres, below which is a layer of nerve-cells; a nerve of precisely the structure of the brain goes on each side for a short distance round the edge of the creature.

The mouth is merely a small perforation of the ventral cuticle, round which the muscles and other tissues do not seem to have undergone any special modification; the alimentary tract consists of a large mass of protoplasm, continuous at the sides of the mouth with the general tunic; nuclei seem to be absent, except occasionally at the edge of the mass. Vacuoles are frequently found, containing generally small crustaceans in various stages of decomposition. It is possible that prey are captured by the protrusion of pseudopodia from the mouth.

There is a single testis and a pair of ovaries; the former is a mass of large, deeply staining cells, not separated by any definite investing membrane from surrounding structures; the spermatozoa do not appear to have vibratile tails; the seminal vesicle is simply a space in the general somatic reticulum, which is a little larger than usual. The ductus ejaculatorius appears to be lined by a thick continuation of the ventral cuticle. The ovaries each contained less than twenty ova; each ovum is granular in young and spongy in older specimens; the large vesicular nucleus has a reticulum, which generally breaks up during the preparation of sections; the nucleolus is a remarkable rounded structure of considerable size; the ova are, for a time at any rate, surrounded by a delicate follicular epithelium; no oviduct could be made out, and it is suggested that the ova escape by the mouth. The author was unable to form any opinion as to the presence or absence of an excretory system. Neglecting it, the other characters of *Haptodiscus* seem to be exactly such as might be looked for in a free-living Cestode which had either retained or acquired a mouth. On the other hand, it may be conceived to be a Cestode or Trematode larva which had acquired reproductive organs.

#### Echinodermata.

**Anatomy of Echinothurida and Phylogeny of Echinodermata.\***  
 Drs. P. and F. Sarasin have issued another part of their beautifully illustrated account of their researches in Ceylon; the description of the anatomy of the Echinothurida is chiefly based on their new species *Athenosoma urens*. The skeleton is first dealt with; the ambulacral primary plates do not fuse to form secondary plates. The oral area is just like that of the Cidarida, being covered by five double rows of imbricating plates, each of which is perforated by an ambulacral pedicle.

\* *Ergebnisse Naturw. Forschungen auf Ceylon*, i. (1888) pp. 83-154 (8 pls.).

The interambulacral area of the buccal membrane, in the outer margin of which the gills are placed, is not completely covered by the lateral processes of the ambulacral plates; it is proposed to call the narrow intermediate band the branchial area. This is covered by delicate calcareous plates, and not, as in the Cidaridæ, by plates which are as thick as those of the ambulacral rows. The central anal orifice is surrounded by concentric circles of small calcareous plates; the genital and ocular plates are arranged in a single circle. The former are not perforated by the genital pores, nor is the so-called ocular tentacle always surrounded by the ocular plate.

The remarkable vermiform movements observed by Wyville Thomson in living specimens of *Asthenosoma hystrix* have never been explained. The authors have discovered five pairs of powerful longitudinal muscles running between the ambulacra and interambulacra; these have the form of broad semilunar lamellæ, which consist of a number of separate bundles, one or more of which take their origin from the ambulacral plates. The separate cords take a radial direction, and are collected at a centrum tendineum; they may be called the *musculi motores coronæ*; others are inserted into the buccal membrane, and may be called the *motores membranæ buccalis*. The fibres are smooth. These muscles serve also as suspenders of the enteric canal. After discussing the resemblance of these muscles to the longitudinal muscles of Holothurians, the authors point out the bearing of the facts on the homology of the calcareous ring of Holothurians, which Johannes Müller compared with certain parts of the "lantern" of Echinoids, but which later authors have rather regarded as homologous with the auricles. Their account serves to support the correctness of Müller's view.

The organs of Stewart are well developed in *Asthenosoma urens*, and probably also in all other Echinothurids; as this group is regarded by the authors as the oldest of Echinoids, their presence in the Cidarida must be due to inheritance, and the separation of the latter as Entobranchiata (Bell) from all other Echinoids must be given up. Rudiments of these organs were long since found by Ludwig in the Diadematidæ, and the authors state that they have discovered rudiments in *Toxopneustes pileolus*.

The function of a renal organ is ascribed to the well-known brown body which accompanies the stone-canal, and which has already had so many names given to it, and so many functions ascribed to it. This organ has a central cavity throughout the whole of its length, which ends blindly in the immediate neighbourhood of the pericæsoophageal ring, while it narrows towards the madreporite and becomes a fine canal, which may be called the ureter. This ureter unites with the stone-canal into a common collecting vesicle, which lies just beneath the madreporic plate, with the canaliculi of which it is connected. These observations are confirmatory of the descriptions of some recent French anatomists. The walls of the central cavity are surrounded by branched glandular lobes, which are themselves hollow; all these lateral ducts open into the central space. The glandular tubes themselves are imbedded in a ground-substance of connective tissue; they contain large vesicular elements, which are generally arranged in several layers; these vesicles contain a nucleus surrounded by a rather fine protoplasm, which gives off delicate processes in various directions; these elements call to mind the renal cells of Helicidæ. Connected with the glandular lobes are

funnels which open freely into the cœlom. Blood circulates in the stroma of connective tissue, and chemical investigations are alone now wanting to complete the proof of the renal nature of this much discussed organ. This kidney must be regarded as an annex of the water-vascular system.

After a short notice of the poison-glands the authors pass to a consideration of the affinities of the Echinothuridæ, and the phylogeny of the Echinodermata. The former may be regarded as an independent sub-group of the Echinoidea, distinguished by the flexibility of the test, the imbrication of its plates, the presence of longitudinal motor muscles, small spines invested in tegumentary sheaths, and the great development of the organs of Stewart. They are most nearly allied to the Cidaridæ on the one hand and the Diadematidæ on the other, but of the three they are the oldest. They share the imbrication of all the plates of the body with the Palæechinidæ, which is only an early condition in the Cidaridæ; in the great majority of the Perischochinidæ the test is flexible. In some Asthenosomas the genital orifices are not yet connected with the genital plates, as in most other Echinids. The apical area of *A. urens* is very like that of *Palæechinus elegans*, and appears to be of an older type than that of the Cidaridæ. As to the absence of external gills in the Cidarids, it is possible that they are present in the young and are lost later on, and the possession of buccal clefts would support this view. The investiture of the spines in tegumentary sheaths is an eminently embryonic arrangement, for, as is well known, it is seen in the ontogeny of all the Euechinoidea. The organs of Stewart in the Cidaridæ are rudimentary as those of the Diadematidæ, and they arise from a common source which is to be found in the Echinothuridæ.

The authors bring forward a number of considerations which induce them to support the view, not now suggested for the first time, that the Echinoids are derived from the Holothurians; they think that Perrier's observations on the development of *Comatula* advance the proof that the Crinoids may be referred to the same source. They have less to say with regard to the Asteroids and Ophiuroids, but Agassiz has shown that Asteroids pass through a Holothuria-stage. As to the derivation of these two groups from the Crinoids, the authors are content with a jest, with so little seriousness do they regard it.

Of the Holothurians the apodal forms are, in the judgment of the Drs. Sarasin, the most ancient; these may be derived from an unsegmented worm, while *Balanoglossus* stands quite close to them. The apodal Holothurian is to the beautiful *Actinometra* as the bud is to the rose or the caterpillar to the butterfly.

**Renal Organs of Star-fishes.\***—Dr. A. B. Griffiths has been able to isolate uric acid from the clear liquid found in the five gastric sacs of the common star-fish; no urea, guanin, or calcium phosphate could be detected.

**Anatomy of Ophiurids.†**—M. L. Cuénot has some notes on the anatomy of Ophiurids. The epithelium of the body is distributed irregularly in all except the Euryalida. The colours of Ophiurids are due to very fine refractive granules which appear black with transmitted light. In the forms which live, like *Ophiothrix* and *Astrophyton*, in stony places, there are small hooks on the sides of the arms, and the

\* Proc. Roy. Soc., xliv. (1888) pp. 325-7.

† Arch. Zool. Expér. et Gén., vi. (1888) pp. 33-82 (3 pls.).

spines are longer than in those which live on sand; this difference points to the locomotor function of these appendages.

The form of the large sac which constitutes the chief part of the digestive tract varies in different species; in *Ophioglypha albida* it has five large interradial and five small radial lobes, while in *Ophiothrix rosula* it has only the interradial lobes. In form the digestive tube of Ophiurids is absolutely comparable to that of a young *Luidia* before the development of the radial cæca. There is no muscular layer, or it is reduced to a few scattered and unimportant fibres; the tube is firmly attached to the test by a number of mesenteric bands. The glandular cells which give the tube its dark coloration are similar to the granular cells already described by the author in Asterids, but there is no nervous layer among the digestive cells as there are in them. In the Ophiurids proper the prolongation which connects the nerve-ring with the digestive tube is solely composed of connective fibrils and epithelial nuclei, without any trace of nerve-fibrils, while in the Euryalids it is altogether nervous. Ophiuroids feed on dead or inert material which they gnaw with their peristomial teeth; the digestive tube takes no part in the prehension of food.

M. Cuénot differs from preceding describers of the nervous system, who, he finds, have taken epithelial nuclei for nervous cells. As in the Asteroids there is a nervous ring with radial cords, but while, in the former, the central parts are continuous with the digestive tube and the external epithelial investment, and are as much epithelial as nervous, in the latter the peripheral nerves and their branches to the spines correspond to the superficial nerve-plexus; the digestive nervous band is found in Euryalids only; the Ophiurids appear to be peculiar in the nerves which supply the muscles of the arm and the disc. The only sensory organs are those of touch, represented by the spines, the ambulacral and the terminal tentacles; the olfactory sense which informs Ophiurids of their prey can only be exercised by the tentacles, the nerves of which are sufficiently near to the external medium.

The fluid of the blood is sea-water with an exceedingly small quantity of albumen dissolved in it; the corpuscles are exactly similar to those of Asterids. The colouring matter is not, as has been stated, hæmoglobin, but a ferment which converts peptones into non-dialysable albuminoids. The amœbocytes and their albuminogenous granules are produced by lymphatic glands, and appear to be formed in just the same way as in Star-fishes.

In *Ophiothrix rosula* the respiratory sac is not a mere involution, but sends out a prolongation which passes into the interradial muscle, in such a way as to carry oxygenated fluid to it, and to bring away its products of excretion. The uric salts, guanin, xanthin, &c., pass by osmosis through the walls of the respiratory sacs.

In his account of the ambulacral system the author differs considerably from M. Koehler. He regards the sand-canal as "un simple souvenir morphologique" which may have some function in the embryo, but has almost no importance in the adult.

A somewhat detailed account is given of the vascular system, in which views different from those of preceding observers are expressed.

With the exception of *Amphiura squamata*, all Ophiurids have the sexes separate. The genital organs are of two different types: in *Ophiocoma*, *Ophioglypha*, and *Ophiomyxa*, there are a series of cæca on

the genital vessel, but in *Ophiopholis* and *Ophiotrix* there is a single large organ. It is exceedingly probable that the genital orifices are only patent at the moment of sexual maturity. Spermatogenesis has much the same history as in Asterids, but while in the latter there is a nucleus quite similar to the lymphatic nuclei, in the Ophiurids the initial nucleus undergoes a special mode of development which causes it to increase considerably in size. The primordial ova of Asterids are lymphatic cells, but in Ophiurids the lymphatic cell of the genital cord undergoes first a special development.

M. Cuvénot disapproves of the union of Asterids and Ophiurids. He believes that *Ophiotrix rosula* is the most differentiated type of the latter, as is *Asterias glacialis* of the former. The Ophiurid presents certain characters of very young Asterids, chiefly in the digestive tube and the ambulacral and vascular systems. They differ in the calcareous plate which covers the ambulacral groove, and in the greater perfection and specialization of the nervous system.

The Asterid, the Ophiurid, and the Sea-Urchin, taken when quite young, are absolutely similar; the first have followed most directly the common phylum whence all are derived. The Urchins have become more specialized than the Ophiurids, from the stock of which the Euryalids broke off to become more specialized than the rest. The want of personal study of Holothurians and Crinoids, and the insufficiency of our knowledge concerning these, have caused the author to omit them from his comparisons.

**Development of Comatula.\***—Dr. J. Barrois has investigated the development of *Comatula mediterranea*. The process lasts a week; the first day includes segmentation and blastosphere formation; the second witnesses the establishment of gastrula and blastopore; the third is marked by the formation of enterocœle and intestine; the fourth finishes the development of the visceral mass; the fifth takes effect in the displacement of this mass; the sixth reveals the formation of the skeleton; and the seventh is the day of hatching.

The *segmentation* results, at the 32 stage, in a mass with eight sides, including four blastomeres each. It exhibits eight large blastomeres (endodermic) at the inferior pole, and a cavity opening to the exterior, by a slit between the blastomeres at each pole. The resulting *blastula* loses these two distinctive features of the dividing mass. The *gastrula* is a typically invaginated archigastrula. With the *closure of the blastopore* at the end of the second day, the cells of the endoderm become disposed in several rows, of which the most exterior form the *mesenchyme*. The endodermic sac becomes completely detached from the ectoderm, and is divided by a constriction into two superposed vesicles. The cells of the mesenchyme continue to accumulate on the lower portion of the embryo, which becomes distinguishable into two parts:—the upper part (future calyx) contains the endodermic sac, the lower part (future calyx) contains the mesenchyme. The *enterocœle* is formed at the beginning of the third day. The superior vesicle, just alluded to, elongates; the inferior vesicle gives off two horns, which surround it—a small transitory one on the ventral side and a larger dorsal one which will form the *intestine*. The endoderm is now more delicate than the ectoderm. The latter exhibits on its ventral surface a thickening, which is the first

\* Rec. Zool. Suisse, iv. (1888) pp. 543-651, 6 pls.

trace of the ventral dimple (fossette) of the larva. Indications of the ciliary rings also appear. The superior vesicle divides into two *peritoneal* sacs, while the inferior vesicle is continued upwards with the gut, still quite closed. Thereafter the inferior vesicle divides into two parts, the *water-vascular vesicle* on the left, the *stone-canal* on the right. Compared with other Echinoderms, the peduncular end is anterior, the calycine or blastopore end is really posterior. The gut separates from the water-vascular vesicle, the latter becomes situated on the top of the visceral mass with the stone-canal on the side. The *visceral mass* then acquires the typical form seen in other Echinoderm larvæ, with the gut surrounded by the two peritoneal sacs, and surmounted by the water-vascular vesicle. It alters its position from being parallel with the main axis to being oblique, and eventually becomes parallel with the lesser axis. The accurate details of the *displacement* can hardly be compressed. With the appearance of the *skeleton* various changes have to be noticed. The horseshoe-shaped water-vascular vessel is divided into five lobes; the stone-canal is separated from the latter, and comes to lie transversely below the water-vascular horseshoe. The two peritoneal sacs become unequal and lie obliquely to one another. In the middle of the compact mass of mesenchyme the cells begin to be stratified in horizontal strands. At the same time appear the peduncular cord and the fixing depression.

The *free larva* of the seventh day has a solid stalk cord, formed from concentrically disposed cells, and originating from mesenchyme. The fixing dimple (fossette), situated just at the side of the terminal cap, forms, like the latter, an extremity of the larva, viz. the extremity of the calcareous axis of the stalk, while the cap forms the true extremity of the larva. There is here a coincidence of the two longitudinal axes of the Pentacrine and of the larva. In the free larva, the cap has given origin on its margins to a fifth circle, the visceral mass is slightly turned towards the superior pole, and the hollow (*échancrure*) of the water-vascular horseshoe, at first directed upwards, is turned downwards.

(2) *Metamorphosis*.—The ectoderm loses its divisions and becomes a rounded delicate sac; the ventral dimple is transformed into a thick mass, which invaginates to give origin to the tentacular chamber; the visceral mass continues to become more oblique until it has changed its transverse position for one in which it is directed towards the superior pole of the embryo. The intestine expands into a spherical mass full of nutritive vitellus. The stone-canal opens by a narrow duct to the left. The two peritoneal sacs are decidedly superposed; the original left becomes the peri-oesophageal horseshoe, the original right forms the peritoneal cap. The ventral curvature becomes accentuated, and the stratified portion of the solid mass of the stalk extends from the centre through the entire mass.

(3) *Post-embryonic Development*.—The young Pentacrinæ at all stages appear in profile to be incurved on one side. This is really a continuation of the ventral curvature of the embryo. Stalk and calyx are gradually defined by a thinning off of the entire posterior region. After becoming a simple sac, the *ectoderm* passes through four stages:—(a) the cells are small and closely apposed; (b) they are slightly elongated and separated; (c) they are reduced to delicate fibres, with the slight residue of the cell-body proper at their internal extremity, and surrounded by the preponderant structureless substance filling up the interspaces; (d) the cells become like true connective cells, while

the structureless layer unites with the internal gelatinous layer of the stalk, and the whole looks like mesenchyme without epidermis. Important changes occur in the general disposition of the embryo; thus the mesenchyme is turned out of the general cavity to form with the modified epidermis the thick cortical layer of the calyx. The *water-vascular ring* with five lobes has these trifurcated, and elongated in the arc of a circle. The modification of the *tentacular lobes* and the evolution of the *vestibule*, the changes on the *stomach-caanal* and *peritoneal sacs* are then described. The *gut* arises (1) from the endodermic mass of which the intestinal portion opens (without ectodermic invagination) on the ventral surface to the right, and (2) from the oesophageal invagination which meets the stomach.

(4) *Critical portion*.—Dr. Barrois then proceeds to a critical review of the results of previous investigators. He afterwards devotes special chapters to the development of the ciliary bands, of the ten primitive limy pieces, of the buccal and anal apertures. Some account is given of aberrant metamorphoses.

One of the most important results of this valuable investigation is the establishment of the homology between the peduncle of the larvæ of *Comatula* and the preoral lobe of other Echinoderms, between the calyx of the former and the proper body of other larvæ. In making a comparison between the different larvæ, the author emphasizes, among others, the following four points. (1) The vestibular invagination of the *Comatula* larvæ, instead of being superposed to the buccal pad, occupies on the left a position exactly congruent with that occupied by the amniotic cavity described by Metschnikoff in sea-urchins—a cavity namely, which incloses the five primitive tentacles of the young Echinoid, and is situated in the left half of the sub-umbrella. (2) The water-pore, situated at first on the left surface of the embryo, comes to lie on the dorsal surface, in a position, that is to say, corresponding to that in all other Echinoderm larvæ. (3) The dorsal limy plates really occupy a similar position in *Comatula* larvæ and in other Echinoderms. (4) The same is true of the stomachic and intestinal branches of the endodermic gut. The displacement marked by the difference of position of blastopore and anus, may also take place in other Echinoderms. Two differences are to be noted: (*a*) in the displacement of the body proper or calyx, and (*b*) in the fact that the ventral and dorsal surfaces of the larva correspond to the ventral and dorsal surfaces of the adult, a condition associated with the change of position exhibited by the two peritoneal sacs. But the unity of development among Echinoderms is nevertheless emphatic.

'Challenger' *Comatulæ*.\*—Dr. P. H. Carpenter completes his work on the Crinoids of the 'Challenger' by this volume, which deals with the unstalked forms. One hundred and twenty species of *Antedon* and forty-eight of *Actinometra* are now known, and of these seventy-nine were discovered by the 'Challenger.' The other genera of this family are *Eudiocrinus*, *Atelecrinus*, *Promachocrinus*, and *Thaumatocrinus*; of these *Promachocrinus* differs from all other Crinoids in having ten primary radials to its calyx, in place of five only.

The author deals with the morphology of the centrodorsal and calyx, and the geographical, bathymetrical, and geological distribution of the

\* 'Challenger' Reports, lx. (1888) ix. and 401 pp. (70 pls.).

group; he adopts the method of formulation, on which he has already written, and discusses in great detail the species found in this large collection.

#### Cœlenterata.

**Development of Hydridæ.\***—Prof. A. de Korotneff has made a study of the ova of *Myriothele*. He finds that the egg arises from a primordial cell of ectodermic origin; this cell gives rise to secondary germinal elements, of which there are more than twenty; of these one alone produces the true germinal vesicle, while the nuclei of the other elements disappear without leaving any trace behind them; the nuclei of the vitelline cells are converted into fatty or vitelline globules, and all this mass of cells collects and forms a common mass which possesses one germinal vesicle. From this point of view the egg itself ought to be considered as an agglomeration of elements, the functions of which are very different; one of the secondary germinal cells gives up its nucleus to the egg, and this serves as the germinal vesicle, the other germinal elements produce the formative plasma of the egg, while the rest gives rise to its vitelline parts. At the same time, each of these three kinds of elements takes part in forming the plasma of the egg.

The mode of origin of the male sexual products is altogether similar to that of the females. Fecundation appears to be effected by the penetration of spermatozoa into the peduncle of the egg.

Metschnikoff has thrown doubt on the author's earlier account of the remarkable mode of development of *Myriothele*, but later observations have convinced Prof. Korotneff that he was quite correct. The free ovum, fixed by its peduncle, has no envelope whatever; after a short time, however, one appears, which may be regarded as a vitelline membrane; it is delicate, yellowish, and fairly resistant. As Prof. Allman discovered, the median part of *Myriothele* produces long delicate filaments with small tentaculiform heads at their free extremities. When the vitelline membrane is formed, three or four of these heads attach themselves and hold the egg in a certain position. At the same time the connection between the egg and its stalk diminishes, the egg separates from the stalk and remains fixed to the animal by the filaments. Analogous phenomena may be observed in fresh-water *Hydræ*.

In the egg itself there may be distinguished a central, finely granular mass, a cortical layer altogether devoid of ectoplasmic vesicles, and vitelline globules or modified nuclei, which are found in the endoplasm only. Of the succeeding stages, some only were seen. There is an active multiplication of the embryonic cells of the ovum, and a morula results. The internal mass forms the endoderm, and this primitive endoderm is not, as in most Arthropods, replaced by a secondary endoderm.

**Flabellum.**†—Dr. G. v. Koch has made a close examination of the arrangement of the septa in *Flabellum Michelini* and *F. pavoninum*. Both species afford, in his opinion, ideal examples of a law previously enunciated by him, viz.—In the Hexacoralla every new septum arises in the space between two that are older, and the septa of every cycle are nearly of the same size. There may be occasional exceptions, and these are due to changes in the general growth.

\* Arch. Zool. Expér. et Gén., vi. (1888) pp. 21–31 (2 pls.).

† Morphol. Jahrb., xiv. (1888) pp. 329–44 (1 pl.).

The author refers to the observations of some recent workers on corals. He urges that he has made sufficient observations on the epitheca of *Astroïdes*, and that Mr. G. C. Bourne's lament is unnecessary. He does not remain silent under Mr. Bourne's treatment of his diagram of the epitheca. There are also replies to other criticisms by Mr. Bourne and Dr. G. H. Fowler, all of which are, to use the author's own expression, "polemisch."

**Sexual Cells and Early Stages in Development of *Millepora plicata*.**\*—Dr. S. J. Hickson, who has already noted that a species of *Millepora* is hermaphrodite, has been continuing his investigations. Both male and female cells arise in the ectoderm of the cœnosarcial canals which anastomose between the dactylozooids and gastrozooids; the young ova become spindle-shaped and penetrate the mesoglaea to enter the endoderm earlier than the spermatospores. As soon as the latter have taken up their position in the endoderm their nucleus increases considerably in size, the protoplasmic meshwork splits up into a number of hook or rod-shaped pieces, and then divides again into a large number of very small particles. The male spores now migrate along the canals to the zooids, in most cases choosing the dactylozooids, but occasionally the gastrozooids; and they pass into their cavity, which, by the disappearance of the surrounding membrane of the spermatospore, is occupied by a swarm of young spermatoblasts. Again entering the endoderm, they push out the mesoglaea into a number of diverticula between the tentacles, in which they remain till they are mature; these diverticula, or sporosacs, vary considerably in number. As the author was unable to find any trace of the formation of the sporosac before the advent of the spermatoblasts he thinks that these must be the active agents in the formation of the sporosacs; or that, in other words, they do not migrate to any locality or structure already prepared for them, but choose for themselves localities which can readily be pushed out in the form of sporosacs.

As the ova increase in size they become stalked, the stalk remaining attached to the mesoglaea; this stalk is not a separate structure, but merely a pseudopodium modified for the purpose of retaining the ovum in position. Two polar globules are successively given off. During the formation of the second spindle, and subsequently, the substance of the ovum becomes clouded and heterogeneous, as if some considerable disturbance of the protoplasm was going on. After impregnation the ovum again becomes clear and homogeneous; the nucleus, soon after its reappearance, is seen to be filled with a number of small spherical bodies like nucleoli; the wall of the nucleus next disappears, and then spherical bodies, together with a number of very small fragments, are seen scattered about in that region of the ovum which was formerly occupied by the nucleus; later on, they migrate and form an equatorial zone of two or three rows; this zone divides into two clusters of fragments, which are eventually scattered over the whole ovum. Favourably stained specimens show that each fragment is surrounded by its own proper protoplasm; this is the morula stage, which is succeeded by a solid blastosphere. The embryos are then, probably, set free into the sea as ciliated larvæ.

The migration of the sexual cells into the endoderm may be ex-

\* Phil. Trans., clxxix. B. (1888) pp. 192-204 (2 pls.).

plained by the presence of a hard, inflexible, calcareous exoskeleton, while the possibility of better nourishment in the endoderm should be taken into consideration.

There is no good reason for associating *Millepora* with *Hydractinia* in the zoological system; the Milleporidæ and Stylasteridæ probably belong to a separate stock altogether from the Hydromedusæ, and to one which never possessed medusæ or medusiform gonophores.

**Larval Actiniæ parasitic on Hydromedusæ.\***—Prof. A. C. Haddon has a note on some parasitic larval Actiniæ found at St. Andrews by Prof. M'Intosh. At first sight, these larvæ appear to be young of *Halcapa chrysanthellum*, but they differ in the much less conspicuous longitudinal retractor muscle of the larger tentacles; it may be that Prof. M'Intosh was right in regarding them as young specimens of *Peachia hastata*.

**Scyphistomata of Acraspedote Medusæ.†**—Dr. P. Fischer gives a short account of some Scyphistoma-forms which he examined at Roscoff, and which, though kept under observation for ten days, exhibited no signs of strobilization. A number of explanations, more or less satisfactory, suggested themselves to him.

(1) They were primitive, and ought consequently soon to produce Ephyræ; against this we have the observation that they did not do so.

(2) They constituted the remnants of primitive Scyphistomata after the departure of the Ephyræ. On these residual forms a new colony would be developed, which might strobilate in the succeeding spring. As to this it can only be said that we have as yet no information as to the fate of the remains of the Scyphistoma-larvæ after the formation and departure of the Ephyræ.

(3) They were primitive, but born late, and so had to retain their actiniiform stage until the succeeding spring. Here, again, we know little as to the influence of the date of birth on the further development of Scyphistoma.

(4) They arose from an acraspedote Medusa which does not strobilate, but passes at once into the Ephyra-stage; but the irregularity of the numbers of their tentacles is against this view.

**Supplementary Report on 'Challenger' Actiniaria.‡**—Prof. R. Hertwig has a second report on the *Actinaria* collected by the 'Challenger,' which affords him an opportunity for making some critical observations on Andrès' monograph of the group. A good deal of the more interesting part of this report is contained in the extracts from Dr. Erdmann's investigations into the anatomy of the Zoantheæ, which we have already noticed.§

#### Porifera.

**Boring Clionids.||**—M. Nassonoff has investigated several species of Clionids, and especially a new species, *C. stationis* Nass., which lives on

\* Ann. and Mag. Nat. Hist., ii. (1888) pp. 256-9.

† Bull. Soc. Zool. France, xiii. (1888) pp. 96-9.

‡ 'Challenger' Reports, lxxiii. (1888) 56 pp. (4 pls.).

§ See this Journal, 1886, p. 454.

|| Arch. Slav. Biol., iv. (1888) pp. 362-6. Bull. Soc. Nat. Moscou, i. (1888) p. 236.

the shells of *Ostrea* and *Mytilus*. He arrives at the following conclusions:—

The boring of the canals and galleries is performed solely by the soft parts of the sponge. The penetration of the prolongation of the body of the sponge into the limy substance of the support appears to be accomplished by the secretion of a corroding liquid, probably an acid. The perforation has only been observed in young specimens, but it is probable that the same thing takes place in the adult. The secondary canals formed by the prolongations are only the rudiments of the larger canals or galleries; the smooth canals crossing the shell may be for orientation. In species which are very small compared with the mass in which they are buried, the limy substance is simply protective. In other species the sponge encircles the shell as well as penetrates it, and in such cases the support has the same rôle as any other skeleton, siliceous or calcareous. The destructive action of the sponge is considerable.

**Formation of Ova and Spermatozoa in *Spongilla fluviatilis*.\***—Dr. K. Fiedler has made an examination of the developmental history of the generative products of the fresh-water Sponge. A necessary preliminary study is the investigation of the various cell-forms which are found in the mesoderm—or, to use a more indifferent expression—in the layer of connective substance or the internal parenchyma. These cells fall into two groups, for some are cells with regularly, and others with irregularly granular protoplasm.

The former were long unobserved; in *S. fluviatilis* they were first seen by Weltner, and later on, independently, by the author. The granules of the protoplasm are spherical, and all of much the same size; a clear marginal zone of quite transparent protoplasm often remains quite free from granules. The chromatin of the nuclei of these cells has always the form of a more or less fine framework, and as a rule there are no nucleoli in it. There can be no doubt that these cells are capable of amœboid movement. They are scattered through the whole of the body, but are most abundant near the free surfaces. It is very probable that they have a nutritive function. The author enters with some detail into the vexed question of the method of nutrition in Sponges.

The greater part of the parenchyma of the sponge is made up of cells of the second kind, or those in which the granulation of the protoplasm is irregular. In some of these the nucleus has a filamentar framework of chromatin, in which there are no nucleoli, while others have a rather large, highly refractive nucleolus and very little chromatin; in the first category are included the slightly specialized ordinary connective-tissue-cells, which, at the time of formation of the generative products, take an important part in the formation of the follicle and Schulze's contractile fibre-cells; in the second category are the ovarian cells, the silicoblasts, and some forms of amœboid migratory cells.

The young ova are distinguished not only by their size and, generally, rounded forms, but by their very clear, because very finely granular, protoplasm, and their sharply limited vesicular nucleus, which is large, not only in comparison with other cell-nuclei, but with that of the egg-cell itself. In some cases there is a zone free of granules around the nucleus, and the protoplasm has a rather faint radial striation. The centre of

\* *Zeitschr. f. Wiss. Zool.*, xlvii. (1888) pp. 85-128 (2 pls.).

the nucleus is occupied by a nucleolus which stains very easily; the rest of the nuclear cavity is clear, and is often, especially in the later stages of development, traversed by a few chromatin filaments, while small spherules of chromatin are deposited at the periphery. The ova exhibit great variability in their position relatively to the other cells of the parenchyma; the follicle first arises owing to the continuous growth of the egg-cell, the pressure thus caused producing an approximation of adjacent cells. The older follicles are more like one another than the younger. Those of the young egg consist of cells varying in number and form. The history of the follicle is described at some length.

When the egg-cell has attained its full size the changes begin in it which have been associated with the "maturation of the ovum"; the nucleus wanders towards the surface to eliminate the directive corpuscles; it is to be noted, however, that the characteristic spindle-figures have not yet been observed. The whole process of segmentation is never the so-called indirect, but always a modified form of direct nuclear division.

The cells of *Spongilla* which give rise to the spermatozoa have a rather finely granular protoplasm and a proportionately large nucleus; the latter consists of a thick network of chromatin with numerous nucleoli which appear to lie at the nodal points of the network. Two nuclei next appear, one of which is as rich in chromatin as the first nucleus, while the second, which is more superficial in position, is very much poorer in chromatin and somewhat smaller. Its protoplasm was sometimes found to be separated by a fine line from that of the inner nucleus. Later on this separation becomes more distinct, and it is seen that a delicate layer of protoplasm with a double contour incloses a number of cells which are to be regarded as the products of division of the internal nucleus and of its protoplasmic investment. The ripe spermatozoa have a spherical head and a small tail which is set in the direction of the long axis of the head.

The male elements of *Spongilla* are so small as to come almost to the limits of vision possible with our Microscopes. The author compares and discusses his results with those of observers of the spermatogenesis of other species of Sponges.

**Remarkable Spicules from the Oamaru Deposit.\***—Mr. B. W. Priest has found in some material from the deposit from Oamaru, New Zealand, two spicules, one an acerate, the other a trifold, in which the enlarged axial cavities have a spiral, vermiform body lying within them, and perfectly siliceous. The author cannot "quite grasp the idea" of a vegetable organism penetrating a siliceous substance, "excepting that some chemical caustic action is set up."

#### Protozoa.

**Phylogeny of Protozoa.**†—Prof. O. Bütschli has published an interesting introduction to his first volume on the Protozoa. After an important historical account, he gives a phylogenetic table (see next page), which exhibits his own views on the classification of the group.

The root of all the unicellular forms must be sought for not in amœboid organisms, but in those which stand between the Sarcodina and the Mastigophora; they are, perhaps, best retained by the Rhizo-

\* Journ. Quek. Micr. Club, iii. (1888) pp. 254-6.

† Bronn's Klassen u. Ordnungen, i. Protozoa (1888) pp. i.-xviii.

mastigoda. With regard to Haeckel's suggestion that the simplest forms are the Monera, or organisms without a nucleus, it must be borne in mind that this was made when the methods of nucleus-investigation were much less complete than they are now, and before it was recognized that the place of a single large nucleus is often taken by a number

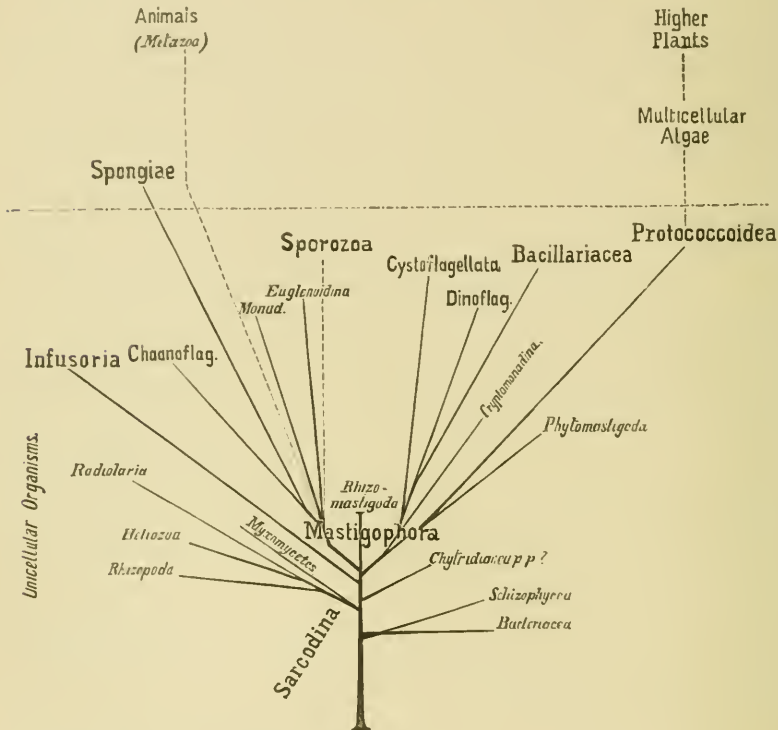

of small and scarcely distinguishable bodies. Both botanists and zoologists now allow that nuclei are often not really absent from organisms which were supposed to be without them. In fact it is generally agreed that, with the exception of the Schizophyceæ and Bacteriaceæ, nuclei are generally present. The author himself has never met with a *Protomaba* or a *Protomonas*, and other observers have said the same. Much has been written on Bacteria, but very little from a morphological point of view; Schmitz has shown that in the protoplasm of the Schizophyceæ there is a varying number of granules of different sizes, which are sometimes collected into one group. It is possible that these are nuclein-grains; De Bary found colourable granules in the protoplasm of certain Bacteria, and it must not be positively asserted that these forms have no nuclei. On these grounds Prof. Bütschli refuses to regard the Monera as the starting-point of the higher unicellular organisms.

The origin of the group of Infusoria is uncertain, owing to the want of connecting forms; but it seems to be clear that it is not either a

differentiated branch of the Mastigophora nor derived from any more ancient lateral branch of the main trunk. Some branches of the Mastigophore-trunk lead no doubt to new and very significant developments. The Bacillariaceæ form an isolated branch which may have had close relations to the Dinoflagellata. The origin of the Sporozoa is involved in great obscurity; it is possible that they branched off from the main trunk much earlier than is here represented, and somewhere near the Chytridaceæ; this remark applies only to the Gregarinida, as the relations of the other so-called divisions of the Sporozoa to them are still very doubtful.

There can be no doubt as to the connection between the Protococcoidea and the Phytomastigoda, and it is almost certain that the higher multicellular plants were derived from them.

Prof. Bütschli doubts whether the Sponges have any relation to the Choanoflagellata on the one hand, or the rest of the Metazoa on the other. We have as yet no intermediate forms between the Metazoa and the Mastigophora. He is inclined to accept with modifications Haeckel's conception of a kingdom of Protista; he extends it, indeed, for he regards the morphological agreement of a unicellular nature as the fundamental character; but this does not prevent his seeing that in practice the groups will fall into the kingdoms of Plants and Animals. The divisions which in his work on Protozoa he treats of have no right to be regarded as forming a natural group; they are those which, on account of their physiological characters, have been hitherto conventionally regarded and described as animals. They are the Sarcodina, Mastigophora, Sporozoa, and Infusoria.

Three further parts of the general treatise \* have been issued, in which, *inter alia*, the ciliation of the peristome and mouth, the endoplasm, the nutrient vacuoles and ingestion of nutriment, the contractile vacuoles, the trichocysts, and the pigments of the Ciliata are discussed.

Notes on Protozoa.†—Prof. A. Gruber communicates some detached observations on Protozoa.

(1) *The encystation of Euglypha alveolata*.—The small plates, originally intended for a process of division, are utilized when encystation sets in for the construction of the so-called internal shell. When the encysted state is abandoned and the sheath bursts, the inner shell is resolved into its component parts. In the subsequent division these are utilized for their original purpose, and form the shell of the daughter-Euglypha.

(2) *The division of Diffugia*.—The point emphasized is the puzzling way in which the *Diffugia* seems to take in as many particles as are necessary for the formation of a new shell, and the fact that we seem bound at this low level to speak of "an artistic impulse and of instincts."

(3) *Nervous system of Infusorians*.—In support of his conclusion that the nervous functions of Infusorians are diffuse, Gruber describes the interesting habit of a *Stentor* which he cut in longitudinal halves, and which reunited with the ends of the halves reverse, but still remained as good a unity as before. A similar experiment with a *Volvox* colony is described.

\* Tom. cit., parts 47-99 (1888) pp. 1377-1488. Title-pages and tables of contents for Abth. i. (Sarcodina and Sporozoa), and Abth. ii. (Mastigophora) are also published.

† Ber. Nat. Gesell. Freiburg, ii. (1887) pp. 149-62 (1 pl.).

(4) *The specific distinctions of Amœbæ* are finally discussed. The apparently simple protoplasmic body is in reality very heterogeneous. The fine differences between the species are far from passing phases, but express constant protoplasmic qualities.

**Various Cyst-formations and Developmental History of Colpoda.\***  
—Herr L. Rhumbler has investigated the life-history of this holotrichous Infusorian. In discussing the granular deposits on the endoplasm and the metabolism of the Infusoria, he points out that the corpuscles are of service in assimilation, as they convert the useful stuffs of the ingested food into protoplasm. Assimilation is only effected with the aid of water containing oxygen, and taken in from outside the body. This traverses the clear zones of the assimilation-corpuscles, and after giving up its oxygen, is driven to the exterior by the vacuole. These assimilation-corpuscles give off their assimilated protoplasm for the purpose of forming new parts, and for the further growth of the rest of the endoplasm. As the final product of metabolism, they excrete uric acid in their interior, where they are gradually collected. The corpuscles are finally destroyed. When this happens the outer protoplasmic zone of the corpuscles is again given up to the endoplasm, while the particles of uric acid are passed to the exterior by the contractile vacuole. This last is, therefore, both an excretory and a respiratory organ. In this Infusorian, further, assimilation and respiration are united in one process.

The cysts of *Colpoda* are of three kinds: dividing cysts, lasting cysts, and sporocysts. The first of these is characterized by an orifice in its wall, by the presence of nutrient spheres in the endoplasm, by the undisturbed pulsation of the vacuole, and by the process of division. The lasting cyst has none of these characters. The sporocyst is distinguished by being protected by two (sometimes three) envelopes; the contents are such that the primitive organization of the *Colpoda* can no longer be recognized; the assimilation-corpuscles are broken up and their uric acid excreted; the sarcodæ, by the loss of the water, is condensed to an eighth; the nucleus is no longer apparent; and the body-wall itself is to all appearance lost.

These various cysts may, under certain circumstances, be converted into one another, the dividing cyst becoming a lasting cyst or a sporocyst, and the lasting cyst a sporocyst. The latter may be effected either by the particles of uric acid from the assimilation-corpuscles and the watery fluid being slowly expelled by the vacuole, or by both gradually passing from all parts of the periphery of the body into the velar space. It is clear that the sporocyst cannot be converted into any other kind of cyst, if we reflect that the complete degeneration of the organization shows that the animal has come to an end of its individual life.

On the first appearance of the dividing cyst, its movement in more or less straight lines is often broken by rotatory movement. The lasting cyst moves rapidly across the field of vision, and the sporocyst still more rapidly. The first has nutrient spheres within, the other two have expelled them. While the gelatinous envelope is being excreted and hardens, the dividing cyst rotates around the long axis of the body or remains at rest, and the contractile vacuole is always at the same place, so that there is an orifice in the wall of the cyst; the other two forms rotate around various axes, the vacuole appears at different points, and there is no orifice in the cyst-wall. During and after the hardening of the cyst-wall

\* Zeitschr. f. Wiss. Zool., xlv. (1888) pp. 549-601 (1 pl.).

the cilia of the sporocyst alone remain. The number of beats of the vacuole of the dividing cyst remain normal, since fresh water can be constantly forced into the body by the orifice; in the lasting-cyst the number rapidly decreases and becomes zero, as the cyst-wall hardens and no more can enter. In the sporocyst the number of beats remains unaltered, but as there is no orifice in the cyst-wall by which fresh water can enter, the volume of the body of the animal diminishes, and an intermediate space appears between the cyst (velum) and the animal, and into this the vacuole-water is driven. The further changes which appear in the dividing cyst are the formation of walls and nuclei for the divided parts, and new formation of vacuoles in the parts of the dividing-cysts. In the sporocyst the volume of the body diminishes to one-eighth of its original extent, while the nucleus and the pellicula disappear. New cilia next become formed in the dividing cyst, and two or four parts swarm out by the orifice; the thickened protoplasm of the sporocyst becomes completely homogeneous, and a second cyst-wall (the true sporocyst-wall) becomes excreted. The characters of a complete dividing cyst are a simple wall with an orifice at one pole, several parts (two to four) in the cyst, nutrient spheres, assimilation-corpuscles, and a normally pulsating vacuole; those of the lasting-cyst are a simple (generally thick) wall without any orifice, one animal in the cyst, assimilation-corpuscles, but no nutrient spheres, the vacuole does not pulsate, and is either dilated or compressed and invisible. The sporocyst has double walls and no orifice; its contents are completely homogeneous and opalescent; there are no nutrient spheres, assimilation-corpuscles, or pulsating vacuole.

The object of the dividing cyst is protection during the formation of two or four parts, and its duration is from two to twelve hours; that of the lasting-sphere is protection from drying, and its duration one to four hours. The sporocyst is for the formation of spores, and lasts from a half to one hour.

The development of *Colpoda* shows that the "biogenetic fundamental law" applies to the Monoplastida, for we have (1) a non-nucleated spore-stage, (2) a multinuclear, and then (3) a uninuclear amoeba-flagellate stage, and (4), finally, the young *Colpoda*. This form is a very primitive Ciliate; the structure of the nucleus of *Colpoda steinii* is throughout life vesicular, and has just the appearance of the nucleus of a Flagellate, while the division in cysts is perhaps also a sign of affinity with the Flagellata. In the mode of formation of its spores *Colpoda* exhibits many signs of relation to the Gregarinida and Coccidia, as in the disappearance of the nucleus and the formation of a double wall of encystation.

**Ciliary Movement.\***—Dr. J. Clark in investigating the effect of reduced oxygen pressures on the streaming movements of protoplasm, has also made some interesting experiments in regard to the influence of the same condition upon cilia. Removal or reduction of the oxygen caused *Chlamydomonas*, *Euglena*, &c., to pass into the resting stage. Return of oxygen recalled them to activity. *Pleurotricha*, *Stylonychia*, *Paramæcium* required less than 1 mm. oxygen pressure to revive them; others even less. He describes an interesting experiment with a *Stylonychia*, which, at a temperature of 17.2° C., was brought under a pressure of 2.5 mm. In four minutes it became quiescent, and rapidly

\* Ber. Deutsch. Bot. Gesell., vi. (1888) pp. 273-80.

began to break up. After it had lost a third of its substance, the pressure was raised to 6 mm. The disruption ceased, and the animal, in spite of diminished body, was soon moving actively as before. With a *Pleurotricha* the experiment was repeated thrice in succession, with repeated diminution of the substance, but to the last with power of recovery on restoration of the original conditions.

**New Parasitic Ciliated Infusorian.\***—Dr. G. Cattaneo describes a new species of ciliated Infusorian which was found parasitic in the blood of *Carcinus mænas*. It appears to belong to the holotrichous family Eueheliidae, and to Cohn's genus *Anophrys*; it may be called *A. Maggii*. The body is oval and elongated, 35–45  $\mu$  by 10–12  $\mu$ , rounded posteriorly, while the anterior part is recurved like a beak, beneath which is the oral opening. It may be noted that the two species already described, *A. carniun* and *A. sarcophaga*, live in sea-water in which there is decomposing flesh.

**Fresh-water Infusoria of Wellington District, New Zealand.†**—Mr. W. M. Maskell observes that there is often no absolute stability, even in the same individuals, among Infusoria. The members of the Wellington Microscopical Section have, therefore, thought it best to avoid describing as new any species about which there might be doubt. He contrasts this with the method adopted by Prof. A. C. Stokes in dealing with American Infusoria.

**Euglena.‡**—M. A. G. Garcin states that this note is brought forward in order to throw some light on the vegetable nature of the genus *Euglena*. *Euglena* either divides by bipartition, or else becomes rounded off and forms a cyst. The cyst at a given moment bursts, and by the opening thus made a crowd of small *Euglenæ* escape, being formed by the division of the encysted protoplasm; they enlarge and become rapidly similar to their parents. The author then describes the development of *Euglenæ* in a humid atmosphere, in which alone it takes place. It commences by rounding off and forming a cyst with a thin wall; then, after resting a certain time, this cyst divides into two. The bipartition continues by a process which might be compared to the segmentation in the egg of Mammifers. The author then compares *Euglena* with *Protococcus viridis*. The cell of *Protococcus* is compared with the cyst of *Euglena*; both are green and globular, and both possess a membrane of cellulose. In a humid atmosphere the cells of both produce, by repeated bipartition of the protoplasm, a mass of immobile spores.

The author concludes by stating that *Euglena* is an alga of the family Siphonææ (tribe Sciadieæ). The thallus is a globular cell (cyst) which, after having vegetated, gives rise to a crowd of zoospores, which enlarge and round off and reproduce the thallus.

**New Monad, Endobiella Bambekii.§**—Dr. C. de Bruyne has found in the cells of *Chara* a monad which he has called after Prof. E. Bambeke. The cultivation method consists in placing some of the pale cells of *Chara vulgaris* in a moist chamber wherein the parasites could be examined during several days. The development of bacteria was prevented by means of some green algæ. The parasite has three stages of

\* Zool. Anzeig., xi. (1888) pp. 456–9.

† Ann. and Mag. Nat. Hist., ii. (1888) pp. 275–6.

‡ Morot's Jouru. de Bot., ii. (1888) pp. 241–6.

§ Centralbl. f. Bakteriol. u. Parasitenk., iv. (1888) pp. 1–5 (1 pl.).

development, being found as a zoospore, an amoeba, and also in a resting state.

The zoospore is a spherical body, and possesses a cilium  $1\frac{1}{2}$  to  $2\frac{1}{2}$  times its length. It contains 1 to 2 contractile vacuoles, numerous drops of oil, and a nucleus which is only demonstrable after fixation with picric acid, washing with spirit and water, and staining, say, with gentian violet. The transition stage to the amoeboid form is shown by the gradual diminution and finally the cessation of movement of the flagellum.

Amoeboid stage. In this condition the animal is less spherical. There are no true pseudopodia, but merely coarse projections. The nucleus is only visible after staining with gentian-violet and previous fixation. The amoeba measures 6 to 9  $\mu$  in length, and 6 to 8  $\mu$  in breadth, is inclosed by a delicate investing membrane, and contains, like the zoospore, numerous small drops of oil. These last gradually coalesce to a single large drop situated excentrically. This forms the transition stage to the resting condition.

In the resting stage the investing membrane thickens, and shows a double contour, while in its general appearance its surface seems covered with curved facets. This membrane does not stain blue with the chlor-zinc iodine solution, thus showing the absence of cellulose. It is coloured red with congo. The spores contain, besides the oil-globules, small slightly refracting spherules. These are not stained by osmic acid, but are by congo red. The author has called his organism *Endobiella*, and regards it as a new genus.

*Monas Dunali*.\*—Dr. R. Blanchard has a preliminary notice on *Monas Dunali*, a flagellate which he regards as the cause of the red colour of salt marshes. This red colour appears in summer, but only in the rectangular compartments at the bottom of which salt is deposited, and the surface of which is covered by a more or less thick crust of salt; in other words, the water of these spaces is saturated with salt.

*Asellicola digitata*.†—Dr. L. Plate has given the name of *Asellicola digitata* to the "gefingerte Acinete" of Stein; it lives on the branchial plates of *Asellus aquaticus*. It is non-pedunculate and hemispherical, and adheres closely to the surface of the gill-plate by its flattened but gently rounded under surface. The thin cuticle is continued over the numerous tentacles which radiate from the dorsal surface. The protoplasm is not divisible into a central or a cortical layer, but is homogeneous throughout. The contractile vacuole, as in *Dendrocometes paradoxus*, opens directly outwards by a small duct, and contracts in such a way that the fluid which has collected in it must be pressed out through this tubule. The striated appearance presented by the protoplasm is not in any way connected with the sucking organs, but has probably only the function of giving the cell-body an increased degree of firmness at its point of fixation, by the development of rigid rods.

The tentacles are remarkably broad, end acutely, vary in number in different individuals, and may arise from any part of the dorsal surface; the plasma is quite free from coarse granules, and in the middle there is a longitudinal canal filled with a limpid fluid, which opens at the

\* Bull. Soc. Zool. France, xiii. (1888) pp. 153-4.

† Ann. and Mag. Nat. Hist., ii. (1888) pp. 208-19 (7 figs.). Translated from Zool. Jahrb. (Spengel), iii. (1888) pp. 143-55.

anterior end. This canal is so fine as to be often invisible in the living animal, but it can be demonstrated with certainty by the aid of osmic acid. Unlike the sucking tubes of most *Acinetæ*, this canal is not continued into the interior of the cell. If one of the tubes of a lively specimen is fixed for a few minutes, the extreme tip raises itself from the tentacle as a distinct tentaculet, which is pushed out and retracted several times a minute. The object of this movement is not clear. The tentaculets very probably secrete a viscid substance, for very small flagellates were often observed adherent to them; in the case of such small organisms the nutriment is simply pumped into the tentacular canal by means of the tentaculet.

The reproduction of *Asellicola* is exactly similar to that of *Dendrocometes paradoxus*, but the process of conjugation exhibits an essential difference. As the *Asellicolæ* do not, as a rule, stand so close as to touch each other, those individuals which are about to conjugate are almost always compelled to unite themselves by a process of the body. For this purpose a tentacle at one end of the body grows enormously beyond its ordinary size; sometimes one only, sometimes both develop a conjugation-tentacle. This tentacle is slowly moved to and fro until the object is attained. When the two animals are united the conjugation canal becomes thicker and thicker, as more of the body-substance from both sides passes into it. Although the cytoplasm of the two animals is very intimately mixed in the canal, the distinctness of the two individuals is not effaced, for, on the least disturbance, the cell-bodies separate from each other in the middle of the canal and lie near each other, covered by a thin membrane. When the canal is completed it swells up, and the nuclei of both individuals migrate into the canal of union and towards one another. They do not, however, seem to come into contact, and they at this time undergo no change of structure, but the author believes that they reciprocally influence one another. After this is effected, the nuclei return to their original position; the plasma returns from the canal of union into the cell-body, and rupture is effected. The nuclei then begin to divide, and finally break up into a number of larger and smaller pieces, which are scattered through the whole of the cell-body. In general it is medium-sized individuals that conjugate, while those that are full-grown form buds.

*Acinetoides*.\*—Dr. L. Plate gives an account of a new genus—which he calls *Acinetoides*—intermediate between the ciliated *Infusoria* and the *Acinetæ*. His examples were found on colonics of *Zoothamnium* from the Bay of Naples. The larger species is called *A. Graffi*, and the smaller *A. zoothamnii*. The anterior end projects beyond the ventral margin of the body in the form of a low cone, bearing in its middle the organ for the inception of nourishment, a sucking thread clubbed at its extremity; this may be traced far into the interior of the cell-body, and is distinguished only by its remarkable shortness and rigidity from the similar organs of most other *Acinetæ*. The ventral surface has an elliptical inner area ciliated; the cilia are arranged in longitudinal rows, and appear to be placed in special grooves. The ventral surface is highly contractile. *A. zoothamnii* was observed to undergo transverse

\* Ann. and Mag. Nat. Hist., ii. (1888) pp. 201-S. Translated from Zool. Jahrb., iii. (1888) pp. 135-43 (3 figs.).

fission ; this is a rare mode of increase among the Suctoria, but common among the Ciliata.

The author is of opinion that the existence of this intermediate form furnishes a fresh argument in support of the opinion already maintained by some naturalists that the Acinetæ are modified Ciliata.

**Parasitic Protozoa.\***—Prof. B. Grassi communicates a number of morphological and systematic notes on parasitic Protozoa which he has studied. (1) What he had described as “*Monere*” (?), Fisch has re-investigated and established as *Grassia ranarum*. (2) Against Danilewsky and Bütschli, Grassi maintains the integrity of his genus *Paramecioides*. (3) He proceeds to consider the morphological features of *Monocercomonas*, *Cimænomonas* (*Trichomonas*), *Trichomonas* Grassi, *Plagiomonas*, and *Amœba coli*. (4) After criticizing Bütschli’s classification and nomenclature, the author submits his own :—

Fam. CERCOMONADINEA Kent emend.

- Gen. 1. *Herpetomonas* Kent emend. (Syn. *Monomita* Grassi.)  
 „ 2. *Trypanosoma* Gruby.  
 „ 3. *Paramecioides* Grassi. (Syn. *Paramecium* Wedl, 1850.)  
 „ 4. *Plagiomonas* Grassi, 1882. (Syn. *Cystomonas* R. Blanchard, 1886.)  
 „ 5. *Bodo* Ehr. (Syn. *Heteromita* Duj.)  
 „ 6. *Monocercomonas* Grassi. (Syn. *Trichomastix* Bloch.)  
 „ 7. *Cimænomonas* Grassi. (Syn. *Trichomonas* Donné.)  
 „ 8. *Costifera* Grassi, 1887. (Syn. *Polymastix* ? Bütschli.)  
 „ 9. *Dicercomonas* Grassi. (Syn. *Hexamita* Duj., *Giardia* Künst.)

Fam. MEGASTOMIDEA Grassi, 1882. (Syn. POLYMASTIGINA Bütschli, 1883.)

- Gen. 10. *Megastoma* Grassi. (Syn. *Cercomonas* Lambl, 1859 ; *Lambliia* R. Blanch., 1886.)

Fam. LOPHOMONADIDEA Grassi.

- Gen. 11. *Lophomonas* Stein.  
 „ 12. *Joenia* Grassi.

The author then gives a useful short summary of the diagnostic characters of the above twelve genera ; and concludes his memoir with some special observations on *Megastoma*, *Trichomonas hominis* Dav., and *Amœba coli*.

**Protozoa found in the Stomach of Ruminants.†**—Herr A. Schuberg obtains fluid from the rumen of freshly slaughtered oxen and sheep without taking any more precautions than collecting the juice in a test-tube and keeping it warm in the breast pocket. On reaching home the tubes are placed in an incubator at 35°–36° whereby the Protozoa were kept alive for about a day, their death probably being due to the decomposition of the gastric juice. The animals may be obtained still more simply from particles of food taken from the mouths of ruminants. Living parasites must be examined on a hot stage, and their movements last longest at temperatures between 30° and 35° in filtered gastric juice.

\* Atti R. Accad. Lincei—Rend., iv. (1888) pp. 5-12.

† Zool. Jahrb. (Spengel), iii. (1888) pp. 365-418 (2 pls.).

The effect of certain reagents (osmic acid 1 per cent.) and dyes (alum-carmine) should also be ascertained. In his present communication the author describes the following Protozoa:—

1. *Buetschlia* with two new species *parva* and *neglecta*. (a) *B. parva* is 0·03–0·53 mm. long, 0·26–0·038 mm. broad, oval, occasionally spherical. The oral aperture is at the anterior extremity and leads into a narrow conical gullet. Ciliation is confined to this extremity, but there is no special arrangement of the cilia. Highly refracting concretions are always to be seen in a vacuole situated somewhere in the anterior extremity. A special contractile vacuole appears to be wanting. Nucleus spherical. Multiplication by division was observed.

(b) *B. neglecta*, 0·057 mm. long and 0·012 mm. broad, resembles in general the last variety, but has in its posterior half four deep pits, so that a transverse section thereof would present the appearance of a cross. Other differences are that this variety presents a tuft of cilia at the posterior and also cilia at the deepest part of the four pits. Vacuoles are always present. The nucleus is large, pale, and spherical.

2. (a) *Isotricha prostoma* Stein, 0·08–0·16 mm. long by 0·053 to 0·12 mm. broad; very frequent; body elastic, not contractile, cylindrical, anterior and posterior extremities pointed, sides somewhat flattened. The whole body is beset with cilia arranged in rows, and beneath the cilia lies a thick refracting membrane, which an addition of water lifts up, preserving its continuity with the body only at the anterior and posterior extremities. Numerous contractile vacuoles in the protoplasm. The nucleus resembles in shape that of the body, and on its dorsal side is a small bright nucleolus. It is especially noteworthy that the nucleus is attached to both the inner and external membranes by fibres, the significance of which is enigmatical. Propagation by fission was observed.

(b) *I. intestinalis* Stein, 0·097–0·131 mm. long by 0·068–0·087 mm. broad, is very closely allied to *I. prostoma*, the most important difference being that the position of the mouth is almost in the middle of the body and also the somewhat more compact form of the nucleolus.

3. (a) *Dasytricha ruminantium* nov. gen. nov. sp., 0·05–0·1 mm. long, 0·025–0·066 mm. broad; very frequently confounded with *Isotricha*. Viewed from the ventral or dorsal aspect the body is oval, from the sides it seems somewhat compressed and bent inwards ventrally. The whole body is ciliated and invested in a double membrane. The mouth and pharynx are situated anteriorly. There is only one contractile vacuole. The nucleus is granular, oval, and possesses a nucleolus lying external to it. There are no nuclear prolongations. Propagation appears to take place by budding.

4. (a) *Entodinium bursa* Stein, 0·055–0·114 mm. long, 0·037–0·078 mm. broad, not very frequent. Body dorsoventrally flattened, somewhat oval, but more obtuse anteriorly. About the centre of the posterior extremity is a somewhat tortuous pit which receives the anal cleft. The cilia are confined to the anterior extremity where the oral aperture leading into a deep conical pharynx is situated. There is a contractile vacuole. The elongated sausage-shaped nucleus has a shining nucleolus. Propagation by fission.

(b) *Entodinium caudatum* Stein, 0·053 mm. long, 0·026 mm. broad, distinguished from *E. bursa* chiefly by its shape, the dorsal surface being less incurved than the ventral which on the left side is hollowed out, and

at the same time elongated into a sort of flat tail-like appendix. On the right side, dorsally and ventral, a pointed lobe projects posteriorly.

(c) *Entodinium minimum* nov. sp., 0.038 mm. long, 0.023 mm. broad, resembles the first species in form, it is, however, smaller. The anus is a fissure.

**New Gregarine.\***—Mr. F. E. Beddard gives a description of a new Gregarine found by him in the vesiculæ seminales and body-cavity of a *Perichæta* from New Zealand. It is from  $1\frac{1}{2}$ –2 mm. in length. The smallest examples had a globular body furnished with one or two slender processes, which are usually of greater length than it, so that the creature may have the appearance of a bead strung upon a thread. Older forms have the body limited by a clear membrane, and there are superficial fibrillar markings. Up to this stage multiplication is by transverse fission. In a third stage the body is covered by a remarkable cyst; this is of great thickness on the processes of the body, though much thinner on the spherical region. In this cyst there are nuclei, and it is probable, therefore, that it is not entirely formed by the parasite; this cyst is quite unlike anything that has been recorded in a Gregarine, but in the Myxosporidia cysts are met with which are nucleated, and, therefore, probably formed pathologically by the tissues in which the parasite lives. The author had not been able to obtain evidence of sporulation, but hopes to be able to do so.

\* Proc. Zool. Soc. Lond., 1888, pp. 355–8.



## BOTANY.

## A. GENERAL, including the Anatomy and Physiology of the Phanerogamia.

## a. Anatomy.\*

## (1) Cell-structure and Protoplasm.

Division of the Nucleus and of the Cell.—Prof. E. Strasburger† follows out his previous important observations on this subject with additional ones, among which the following are the more important points:—

(1) Division of the nucleus and of the cell in *Spirogyra polytaeniata* n.sp. As respects the development of the spindle-fibres, this occupies an intermediate position between species already described.

(2) The resting nucleus. In that of *Fritillaria*, there are no bridges which are less receptive to pigments between the thicker strings of the framework of the nucleus, as Flemming and others have described in the case of *Salamandra*.

(3) Construction of the nuclear threads in the knot-condition. The relatively large chromatin-discs of the nuclear thread during karyokinesis are the result of gradual fusion of the usually much smaller chromatin-balls in the framework of the resting nucleus.

(4) Number of the nuclear threads. Contrary to his previous view, Strasburger has now, in preparations fixed in alcohol, and stained by methyl-blue, and afterwards treated with *cau de Javelle*, demonstrated the segmentation of the nuclear thread in the resting nucleus. In the vegetative organs he found sometimes slight variations in the number of segments during karyokinesis, while in the nuclei of generative cells the number appears to be very constant. It seems probable that the number of segments in the threads of the two nuclei which unite in the process of impregnation is always the same in the higher plants.

(5) The loose knot-condition of the polar field. Strasburger shows that the formation of the segments of the nuclear filaments in the direction of the so-called polar field, first observed by Rabl in animal cells, occurs also in various vegetable cells. He now agrees with Guignard and Zacharias in regarding the structures which he had previously described under the name *paranucleoli* as identical with the *nucleoli* of the nucleus.

(6) Transformation of the nuclear filaments in the formation of the nuclear plate. The author shows that in various vegetable cells the polar field formed at the commencement of the knot-stage lies in the equatorial plane of the figure in the subsequent division of the nucleus.

(7) Origin of the nuclear spindle and formation of the nuclear plate. The polar corpuscles found in animal cells have not been detected in those of plants. Radial structures in the cytoplasm are, however, not altogether wanting during karyokinesis. The processes which take place

\* This subdivision contains (1) Cell-structure and Protoplasm; (2) Other Cell-contents (including Secretions); (3) Structure of Tissues; and (4) Structure of Organs.

† 'Ueb. Kern- u. Zell-theilung im Pflanzenreiche, nebst einem Anhang ü. Befruchtung,' 258 pp., Jena, 1888. See *Bot. Centralbl.*, xxxv. (1888) p. 192. See also *Nature* xxxix. (1888) p. 4. Cf. this Journal, 1883, p. 227.

in the parietal layer of the embryo-sac of *Leucosium æstivum* are described in detail. The nuclei are first of all enveloped in denser protoplasm; but before the absorption of the cellular membrane a spindle-like differentiation of this mass of protoplasm may be perceived. Strasburger shows that the microchemical reactions of the nuclear spindle by no means oppose the theory of its origin from the cytoplasm.

(8) The separation of the secondary segments. In opposition to his previous views, the author now agrees with Heuser and Guignard that the separation of the halves of the segments within the cells of higher plants always takes place so that the end of each half-segment which is directed outwards points immediately after the separation towards the equatorial plane.

(9) Absorption of the nucleoli. The differences in the capacity of the nuclear filaments for absorbing pigments observed by Went do not always coincide in time with the disappearance or reappearance of the nuclei; and it is improbable that the nucleoli contribute to the nutrition of the nuclear filaments.

(10) Uniting-threads and cell-plate. In opposition to the recent views of Berthold and Zacharias, but in agreement with those of Guignard, Strasburger shows that, in the higher plants, the spindle-fibres always go from pole to pole, and pass over afterwards into the so-called uniting-threads, the number of which can, however, gradually increase considerably at the expense of the cytoplasm. In their chemical reactions these threads agree altogether with the spindle-fibres. In cells which contain but little protoplasm, these threads form a more or less thick continuous tube extending from one of the two daughter-nuclei to the other, which becomes gradually more and more stretched by the growth outwards of the membrane.

(11) Origin of the membrane. The new membrane arises by the fusion and chemical metamorphosis of the dermatosomes, which are at first simply thickenings of the uniting-threads.

(12) Formation of the nucleoli in the daughter-nuclei. With the new-formation of the nucleoli the nuclear sap loses its capacity for absorbing pigments.

(13) Part played by the nuclear sap and nucleoli. From the facts that the nuclear sap becomes receptive for pigments on the disappearance of the nucleoli during karyokinesis, and that strongly receptive substances accumulate in the neighbourhood of the cell-plate before the formation of the new membrane, Strasburger concludes that the substance of the nucleoli takes part in the formation of the new membrane.

Herr E. Zacharias\* discusses in detail Strasburger's observations, controverting some of his conclusions. He regards Strasburger's explanation of the changes in the nuclear threads, viz. that they result from the opposition of forces in different directions operating within and without the nucleus, as being but imperfectly founded on facts. He disputes the accuracy of conclusions drawn from preparations of nuclei in the knot-condition treated with alcohol or chromacetic acid and stained by safranin or hæmatoxylin, since all parts of the nucleus are not brought out clearly and definitely. Nor can Strasburger's negative results of treatment with methyl-blue and eau de Javelle be set against Zacharias's previous results obtained by other means. Zacharias repeats his previous

\* Bot. Ztg., xlvi. (1888) pp. 437-50, 453-60 (4 figs.).

statement that the mass of the spindle-fibres differs chemically from the cytoplasm—not containing any substance incapable of digestion—and therefore cannot result entirely from the entrance of the cytoplasm into the nucleus. Pollen-mother-cells of *Heimerocallis* freshly observed in white of egg show clearly that the nuclear cavity is, by its homogeneous character, sharply distinguished from the non-homogeneous cytoplasm. Zacharias dissents also in some points from Strasburger's conclusions respecting the constitution of the uniting-threads and the function of the nucleoli.

Strasburger explains the act of impregnation as depending on a union of similar nuclear threads, the further development of which is excited by the mixing of the nuclear sap. Zacharias considers the part assigned to the nuclear sap to be unsupported by direct observation; and that the former portion of this statement is rather a description of the last stage in the process of fertilization.

**Properties and Changes of the Membrane, Protoplasm, and Nucleus of Plant-cells.\***—Prof. C. Frommann has a series of essays in which he deals with points connected with plant-cells. The first is devoted to some structural relations observed in the membranes of the epidermis of the leaves of *Dracæna draco* and *Euphorbia cyparissias*. He comes to the conclusion that the filamentar structures or networks which belong to the membrane and are sometimes connected with the intracellular protoplasm, sometimes resemble those of the latter, and are sometimes much firmer and more refractive; the intermediate substance is sometimes feebly, and sometimes highly refractive; in the latter case it may be the cause of the protoplasmic parts becoming indistinct or disappearing; in homogeneous membranes the protoplasmic structures which belong to the foundations of the membrane may be made visible again by the use of reagents which cause considerable swelling. It must not, however, be supposed that all homogeneous membranes inclose networks or fibrillar structures which belong to the protoplasm. The appearance of large rounded spindle-shaped or irregularly formed and partly anastomosing structures, such as the author has detected in the side-walls of *Dracæna*, lead to the belief that, within circumscribed areas, networks of protoplasm first fuse with one another to form homogeneous bodies; it is only after this that cellulose is formed in them. That membranes are really formed in this way from homogeneous protoplasmic layers is shown in the essay which treats of the formation of cellulose-membranes within the intercellular spaces and the cells of the parenchyma of the knobs of *Cyclamen* and *Phajus*.

The appearance of chlorophyll in cell-membranes has been studied; sections and surface-views show that the cuticle in a number of places either becomes thickened, and beset with knot-like or wart-like growths, or it becomes considerably swollen and softened. In the latter case fine granules and filaments become differentiated and often connected together by plexuses of delicate meshwork. Vacuoles appear at the same time. The layers thus formed extend into the adjoining unaltered or only slightly thickened cuticle. In addition, we find prominent aggregations of granular filamentar substance; from these, newly-formed parts may be differentiated which fuse with those already present. But, when this occurs, several of the green layers are found to have their boundaries

\* Jenaisch. Zeitschr. f. Naturwiss., xxii. (1888) pp. 47-174 (5 pls.).

formed not by filaments or granules, but by a delicate layer of freely projecting homogeneous green substance; sections of uncoloured layers are often observed to have round clear homogeneous drop-like bodies along their periphery. An account is given of the chemical and physical characters of the green-coloured portions of the unaltered cuticle, from which it seems to follow certainly that the green colour is identical with chlorophyll.

The formation and growth of starch-granules in chlorophyll-granules, nucleus, and protoplasm, are next discussed. In all cases starch is formed by the plexuses, or by these and the ground-substance in which the plexuses are imbedded. The plexuses appear in the form of rounded granules; the quantity of starch formed generally increases rapidly, so that the filamentar structure of even the small granules becomes obscured. The growth of the granules is due to apposition, and to either the formation of starch-containing processes or to that of a shell-like covering. Starch-granules which are inclosed by a special thick protoplasmic capsule grow at the expense of the latter. The formation of chlorophyll from starch-grains is treated of at some length.

**Increase of normal Vacuoles by Division.\***—Pursuing his researches on the structure and formation of vacuoles, M. F. A. T. C. Went restates his previous conclusions, viz. :—That all living vegetable cells, with the possible exception of antherozoids, Cyanophyceæ, and bacteria, inclose vacuoles, each of which is surrounded by a membrane of its own, the *tonoplast*.† In all young cells a division and a fusion of vacuoles may be observed. All the normal vacuoles in a plant result from the successive division of that of the oosphere. The tonoplasts are as much entitled to be regarded as organs of the protoplasm as the nuclei or the chromatophores. The protoplasm is always in movement from the youngest state of the cell. Normal vacuoles are never formed at the expense of the protoplasm, but only pathological vacuoles in the case of the disorganization of the tissues.

In certain cases the necessity for the tonoplast is evident, as when the cell-sap contained in the vacuoles is sufficiently acid to kill the protoplasm, as in *Rheum* and *Begonia*. The tonoplast offers much greater resistance to reagents than the rest of the protoplasm. Thus, a 10 per cent. solution of nitre, sufficient to plasmolyse the cell-contents, kills the protoplasm, while the vacuoles remain alive in the form of colourless vesicles. The contents of the vacuoles are an aqueous solution of various substances, some of them crystallizable; the reaction is usually feebly acid, sometimes, as in aleurone-grains, alkaline. At first these substances are chiefly organic and inorganic salts, afterwards glucose, tannin, and albumin. Calcium oxalate occurs in the crystalline state in the cell-sap, but never in the cytoplasm. Albumin may occur in the soluble state, as in the case of albumin tannate or alkaline albuminates, but it may also exist in the crystalline state, as in the crystalloids of *Ricinus* and other plants. When these crystalloids are formed in the endosperm in a state of repose, and surrounded by their tonoplast, they are known as aleurone-grains. On germination, the albumin dissolves and the vacuoles again become clear. Tannin is found only in the cell-sap, and the so-called vesicles of tannin are probably nothing

\* Pringsheim's Jahrb. f. Wiss. Bot., xix. (1888) pp. 295-356 (3 pls.). Cf. this Journal, *ante*, p. 243.

† See this Journal, 1886, p. 637.

but vacuoles; at least this is the case in the leaves of *Mimosa pudica*. Many vacuoles may also contain a pigment, red in acid, blue in alkaline cells, occasionally yellow. These pigments appear to be always connected with the presence of tannin.

When there are several vacuoles in a cell, their contents often differ; thus in many petals each cell has one large coloured vacuole and several small colourless "adventitious vacuoles"; the former contains tannin, while the others do not. This selection of different substances contained in the cell-sap is not due to the granular protoplasm, which is always in movement, but to the tonoplast. The phenomenon is not dissimilar to that displayed by chromatophores; the coloured vacuoles may be compared to chromoplasts, the uncoloured adventitious vacuoles to leucoplasts.

The vacuoles always increase in number by division. The process may be observed in living cells, by allowing the preparations to remain for a time in a 3·5 per cent. solution of sugar. The best materials to employ are the hyphæ of fungi, pollen-grains, and epidermal hairs. In the endosperm a large vacuole divides into a certain number of smaller ones, which become the aleurone-grains; on germination, the albumin dissolves, and the small vacuoles fuse again into a large one. The phenomenon of aggregation in the tentacles of *Drosera* is due to the large vacuoles dividing, as they do under the influence of any excitation, into a large number of small vacuoles, while the volume of the cell-sap diminishes. When the excitation has ceased, the vacuoles fuse again into one large central vacuole.

The principal function of the vacuoles is to incite, by their osmotic force, the turgidity of the cells, thus contributing to the growth of the plant. Another important function consists in storing up substances of all kinds, whether reserve-materials, such as cane-sugar, glucose, and inulin, or tannin, which occurs nowhere else but in the vacuoles, and which appears to serve as a protection against the attacks of animals. It is probable that in the vacuoles are also localized the greater part of vegetable poisons, such as the alkaloids, and that the tonoplast prevents these exercising an injurious influence on the protoplasm. Another class of substances stored up in vacuoles is the pigments, which are chiefly connected with the visits of insects. Finally they contain substances the use of which is at present unknown, such as calcium oxalate. In some cases the function of the vacuoles is still obscure, as in that of the aggregation of protoplasm in insectivorous plants, where they may contribute to the secretion of a ferment, or to the absorption of nutriment.

**Albumen in the Cell-wall.\***—Herr J. Wiesner replies further to Fischer's arguments† against the validity of his demonstration of the presence of albumen in the walls of living cells. He points out that Fischer must be in error in suggesting that the substance supposed by Wiesner to be albumen is in reality tyrosin, since the possibility of the presence of tyrosin is excluded by the process employed.

#### (2) Other Cell-contents (including Secretions).

**Development of Aleurone-grains in the Lupin.‡**—Mr. A. B. Rendle describes the formation of aleurone-grains in *Lupinus digitatus*. Until

\* Ber. Deutsch. Bot. Gesell., vi. (1888) pp. 187-95.

† See this Journal, ante, p. 602. ‡ Ann. of Bot., ii. (1888) pp. 161-6 (1 pl.).

the cotyledons completely fill the seed-coat, there is no trace of the aleurone-grains, the cells contain a conspicuous nucleus slung in the centre by thick protoplasmic bridges, or sometimes lying in the parietal protoplasm. If sections of the cotyledons be examined when the seeds begin to swell, the cells are seen to contain small spherical or oval bodies, partly or wholly projecting from the granular protoplasm, whether the parietal layer or that surrounding the nucleus, or forming the connecting strands. These bodies are the rudimentary aleurone-grains; they increase in size and number and soon fill up the vacuole. The grains, therefore, are evidently actually secreted by and in the protoplasm itself. Solid organic constituents were repeatedly sought for, but without success.

**Occurrence of Starch in the Onion.\***—Mr. A. B. Rendle states that the leaves of the onion are known to be somewhat exceptional in that they do not form starch in the process of assimilation; glucose, which is present in large quantities in the mesophyll-cells, apparently taking its place. From the papers of Böhm, Schimper, A. Meyer, and others, it would appear that the green leaf of the onion does not form starch at all. From the author's experiments, however, it is evident that the onion is rather to be considered as an extreme instance of a plant like *Euphorbia Lathyris*, where the starch is present almost exclusively near the vascular bundle and at the base of the leaves; since, at any rate in seedlings, starch occurs under natural conditions in the same position as in this plant.

**Formation of Starch in the Chlorophyll-grains.†**—Sig. G. Bellucci finds, by experiment on a number of plants, that, during the day starch and glucose accumulate in the plant, especially the latter. By night the starch disappears almost entirely from the leaves, while the quantity of glucose remains nearly unchanged, the loss from metabolism being compensated by constant transformation of starch into sugar. In the grape-vine, if the fruit is cut off, the amount of glucose in the leaves increases, not being used up in other parts. Experiments with cut portions of plants afford no guide for what takes place in the living plant.

**Reserve-substances in Evergreen Leaves.‡**—Herr E. Schulz has investigated the mode of formation and distribution of the reserve-substances, especially tannin, in the leaves of a number of evergreen trees and shrubs, both Angiosperms and Gymnosperms. The following are the more important results:—

Sachs's view that evergreen leaves serve during the period of rest as receptacles for reserve-materials, and Haberlandt's, that the assimilating tissue of evergreen leaves performs this function, are true for Gymnosperms and most Dicotyledons. This accumulation of reserve-substances cannot, however, be demonstrated in the case of Monocotyledons and some Dicotyledons. The author was unable to confirm Zimmermann's statement that the parenchymatous cells which accompany the transfusion-tissue in Coniferæ, and the sheath which surrounds them, contain starch in the dormant period. Haberlandt's assertion that the starch disappears from evergreen leaves in October, and makes its appearance again in

\* Ann. of Bot., ii. (1888) pp. 225-7.

† Staz. sperim. agrarie ital., xiv. (1888) pp. 77-85. See Bot. Centralbl., xxxv. (1888) p. 231.

‡ Flora, lxxi. (1888) pp. 223-41, 248-58 (1 pl.).

March, is only true to a limited extent for Gymnosperms, with the exception of the Gnetaceæ.

The reserve-materials in evergreen leaves consist of starch, fatty oil, and tannin; the latter may be alone or may be accompanied by either of the others. Starch and tannin, however, are seldom found in the same cell; there appears to be a certain alternative relationship between them. Details are given with respect to the special tissue in the leaf in which the tannin is mostly found.

Under the head of both Gymnosperms and Dicotyledones the details of the observations on a number of species are given.

**Glucose as a Reserve-material in Woody Plants.\***—Very few observations have hitherto been made on the occurrence of glucose as a reserve-material. Dr. A. Fischer states that it is of very common occurrence in woody Angiosperms. He finds it especially in the cells of dead tissues from which the protoplasm has disappeared. He never met with it in the living elements of the wood, the medullary rays, or the parenchyma of the wood, in which other non-nitrogenous reserve-substances (oil, starch, and tannin) are stored up. The distribution in the dead elements of the bark, the pith, and the wood, varies very greatly in different trees. The test used for the presence of glucose was the ordinary one of the reduction of oxide of copper.

**Colourless Oil-plastids in Potamogeton.†**—Herr A. N. Lundström observes that the young leaves and stipules of many species of *Potamogeton* exhibit a shining surface, which renders them completely dry even when immersed in water. This is due to large drops of oil in the epidermal cells. The author states that the formation of these oil-drops is connected with certain definite minute bodies contained in them, which he compares with Schimper's starch-generators or leucoplastids, and terms "oil-plastids." They are rod-shaped, from 2–9  $\mu$  in length, and 0.5  $\mu$  in breadth; there is sometimes only one, sometimes two or three are associated with each drop of oil. In living cells they are in a constant oscillating motion. They are not situated in the vacuoles, but in the parietal protoplasm, and are independent of the nucleus. They often disappear very rapidly out of the cells, and are certainly not the direct result of assimilation, being formed long before the chlorophyll-grains.

**Substance of which Gum-arabic is formed.‡**—Herr F. v. Höhnel has determined, by examination of a branch of *Acacia Vereh* to which was attached a large lump of gum, that it cannot have been formed, as is the case with tragacanth and some other gums, by disorganization of the substance of the cell-walls, but that it belongs to the class of gums formed by modification of the cell-contents.

**Tannin and its connection with Metastasis.§**—Herr H. Moeller maintains that tannin arises in the plant as an oxidation product in the transformation of starch; that starch unites with tannin to form a glucoside, possibly grape-sugar or amyloextrin; and that this glucoside splits up easily into tannin and sugar, starch, or cellulose. Tannin is

\* Bot. Ztg., xvi. (1888) pp. 405–17.

† SB. Naturv. Studentsällsk Upsala, Oct. 20, 1887. See Bot. Centralbl., xxxv. (1888) p. 177.

‡ Ber. Deutsch. Bot. Gesell., vi. (1888) pp. 156–9.

§ Ueb. d. Vorkommen d. Gerbsäure u. ihre Bedeutung f. d. Stoffwechsel, Berlin, 1888. See Bot. Centralbl., xxxv. (1888) p. 266.

therefore excreted especially where starch is being displaced or transformed into cellulose, or where metastasis is carried forward uninterruptedly. It is formed in large quantities where respiration is active, as in the assimilating organs, germinating seeds, &c.

### (3) Structure of Tissues.

**Importance of the Foliar Fibrovascular System in Vegetable Anatomy.\***—M. O. Lignier states that, in order to find new taxonomic characters or materials for comparative vegetable anatomy, numerous botanists have studied the course of the fibrovascular bundles. An examination of the facts shows that the fibrovascular system of each leaf is ordinarily independent of that of the neighbouring leaves, and that in each of the bundles that compose the leaf-trace, the differentiation of primary tissues is made from above downwards. The arrangement of the fibrovascular bundles of a stem depends (1) on the symmetry of the stem at the moment of differentiation; (2) on the form of the foliar system. Finally, it is necessary to compare, first, not the course of the bundles in the stem, but that of the bundles in the foliar fibrovascular system of two branches. The study of the contacts which are established between the different leaf-traces ought only to take the second place.

**Wall of Suberous Cells.†**—M. C. van Wisselingh gives the following as a summary of the results of his work:—

(1) The suberous layer does not contain cellulose. (2) After maceration in chromic acid or in potash, or after being heated with solution of potash, the suberous layer is coloured violet by iodine or by chloridide of zinc. (3) In opposition to the cuticularized layer, the suberous layer does not leave the cellulose base when warmed in glycerin. (4) Different chemical combinations, comprised under the common name of suberin, constitute the essential element of the suberous layer. (5) Heated in glycerin at the temperature when fats decompose, the suberous layer undergoes decomposition, which is not preceded by fusion. (6) The temperature at which this decomposition takes place is different for different plants, and often even for different parts of the same suberous layer. (7) The ability to resist the action of potash and other energetic reagents is very different for different elements of the suberous layer. (8) After prolonged treatment by these reagents at ordinary temperature, one is able by pressure to divide the suberous layer into small globular bodies or dermatosomes, which consist of suberin, and in consequence differ from those separated by M. Wiesner from many other tissues. (9) In this treatment the suberin which is found between the dermatosomes undergoes a decomposition, a saponification when potash is employed. (10) When potash is employed, it is found that the connections between the dermatosomes are more easily destroyed in a tangential than in a radial direction. (11) The substances included under the name of cutin resemble those which are united under the name of suberin. (12) The presence of wax is rarer than has been formerly supposed. (13) Undulations may be formed in the suberous layer. (14) In many cases it is not necessary to suppose that a suberification of the middle lamella in the radial walls takes place.

\* Comptes Rendus, cvii. (1888) pp. 402-5.

† Arch. Néerland., xxii. (1888) pp. 253-96.

**Reticulations in Vessels.\***—Dr. O. G. Petersen calls attention to the occasional occurrence of a network with angular, or less often rounded meshes, and very delicate, almost colourless and transparent cell-walls, clothing the cavity of individual cells. This occurs in *Cordia Myxa*, *Bougainvillea glabra*, and *Testudinaria elephantipes*. It presents the appearance of an intermediate structure between tracheæ with bordered pits and sieve-tubes.

**Secretory Canals of Araucaria.†**—M. P. A. Dangeard finds *Araucaria imbricata* to differ from all other Conifers at present observed in the presence of secretory canals in the primary cortex of the root. While in *Pinus sylvestris* each cotyledon receives only one fibrovascular bundle, in *Araucaria imbricata* seven or eight pass into the cotyledons, accompanied by the secretory canals of the pericycle. The number of cotyledons is either two or three. The secretory canals of the stem are independent of the two systems which may be detected in the embryo, the one lying a few layers below the epidermis of the cotyledons, the other more towards the interior.

**Super-endodermal Network of the Root of Leguminosæ and Ericacæ.‡**—M. P. van Tieghem points out that many of the Coniferæ, Rosacæ, Caprifoliacæ, and Cruciferæ have the super-endodermal layer of their root provided with a sustaining network. The author has found a similar network in the roots of certain Leguminosæ, notably *Cassia*, and in certain Ericacæ, more particularly *Clethra*.

**Sub-epidermal Network of the Root of Geraniacæ.§**—MM. P. van Tieghem and Monal state that the root of *Geranium* (*G. molle*, *Robertianum*, *pyrenaicum*, *sanguineum*, *rotundifolium*, *striatum*, *carallianum*, &c.) has below the piliferous layer a layer of large cells, constituting what is usually called the suberous layer or exoderm. Each cell of this layer has on its lateral and transverse face a band strongly thickened towards the interior. This constitutes the sustaining network. The same character is found in *Pelargonium* and in *Erodium*. In *E. arabicum* and *chium* the sub-epidermal network is often interrupted, and sometimes but feebly developed.

**Supporting Network in the Cortex of the Root.||**—According to M. P. van Tieghem, a great number of Dicotyledons and Gymnosperms develop a supporting network in the cortex of their root; this has not been observed up to the present time either in Monocotyledons or Cryptogams. It is formed by a layer of cells being strongly thickened on their radial and transverse septa. This network may be either simple or compound, and may occupy three different positions. Most frequently it belongs to the last cortical layer but one, and is in contact with the endoderm. This may be observed in many Cruciferæ, Rosacæ, Caprifoliacæ, &c. Sometimes, on the contrary, it is the external cortical layer, as in Geraniacæ; while sometimes it may occupy a position intermediate between the two preceding, as in *Rhizophora Mangle*. In fact it will be thus seen that the network may occupy almost any position between the epidermis and the endoderm.

\* Bot. Centralbl., xxxv. (1888) pp. 27-8.

† Bull. Soc. Linn. Normandie, i., 1886-7 (1888) pp. 174-7.

‡ Bull. Soc. Bot. France, xxxv. (1888) p. 273.

§ Ibid., p. 274.

|| Ann. Sci. Nat., vii. (1888) pp. 375-8.

**Exoderm of the Root of Restiaceæ.\***—M. P. van Tieghem states that the cortex of the root of Restiaceæ includes, as usual, two zones, the thick internal layer surrounding the central cylinder, and the external layer. It is in the external cortical zone that the peculiar cortical character which is the subject of this paper resides.

All the Restiaceæ have this common character, that the exoderm is folded; but either this endoderm constitutes by itself the external cortical zone and is derived directly from the differentiation of the initial layer of the zone (as in *Elegia*, &c.); or it is only the outermost layer of a more or less thickened and lignified mass produced by the centrifugal tangential division of the initial layer, and derived by the differentiation of the merismatic layer of this zone (as in *Restio*, &c.).

**Periderm of Rosaceæ.†**—M. H. Douliot states that it is well known that in the Pomeæ the periderm originates in the epidermis, while in the Amygdaleæ and Pruneæ it originates in the first layer of the cortex situated immediately beneath the epidermis; in the *Rubi* this same formation originates in the endoderm; and finally, as in the case of *Spiræa opulifolia*, it may originate in a layer of cells situated beneath the endoderm. It is thus seen that the periderm may be formed in four different places in the stem of Rosaceæ, but the last case of all, where it originates beneath the endoderm, that is, in the pericycle, is by far the most common, and examples are met with in the Spirææ, Fragariæ, Poteriæ, and Roseæ. The author concludes by describing in detail the formation of the periderm in *Alchemilla vulgaris*.

**Plants which form their Rootlets without a Pocket.‡**—MM. P. van Tieghem and H. Douliot have already shown that rootlets and lateral roots are formed in the pericycle by two successive tangential divisions. There are, however, certain secondary differences which are of interest, and which vary in the different families, as, for example, that the root or rootlet is sometimes naked, sometimes enveloped in an endodermal "pocket." Among Dicotyledons the authors have observed the formation of rootlets without a pocket in fifteen families:—Cruciferae, Capparideæ, Fumariaceæ, Papaveraceæ, Resedaceæ, Caryophyllaceæ, Portulacaceæ, Illecebraceæ, Crassulaceæ, Chenopodiaceæ, Amaranthaceæ, Baselleæ, Aizoaceæ, Cactaceæ, and Begoniaceæ. In Monocotyledons the absence of a pocket is very rare, and the only instance cited by the authors is *Pandanus*. In Gymnosperms the Abietineæ are destitute of a pocket, also *Taxus*, *Podocarpus*, and *Sequoia*.

**Observations on Pinguicula. §**—M. P. A. Dangeard continues his observations on *Pinguicula*. An endoderm exists in the stem of all the species the author has examined, the cells of this layer being often rectangular. The bundle which passes into the leaf proceeds from two different sympodia. These sympodia follow in the stem a course analogous to that found in *Primula spectabilis* or *Androsace septentrionalis*; they, however, may be found arranged in two different ways. The sympodia either form a normal annual ring, or they are the same as in the lower part of the stem. From this anatomical point of view, then, the genus *Pinguicula* can be divided into two sections.

\* Bull. Soc. Bot. France, xxxiv. (1888) pp. 448-50.

† Ibid., pp. 425-7.

‡ Ibid., xxxv. pp. 278-81. § Ibid., xxxv. pp. 260-3. Cf. this Journal, *ante*, p. 74.

**Anatomy of the Salsolæ.\***—M. P. A. Dangeard states that the Salsolæ present several interesting structural peculiarities. In *Noëa spinosissima* Moq. three fibrovascular bundles detach themselves from those which form the central cylinder of the axillary branch; the median bundle is destined for the leaf, the two lateral ones bifurcate when near the cortex, one ramification approaches the median bundle, while the other furnishes the bundles which are met with in the cortex of the stem. The cortical parenchyma includes (1) the epidermis; (2) a single layer of palisade tissue, interrupted in several places; (3) a layer of cubical cells; (4) a large number of small bundles with the xylem on the outside; (5) a colourless parenchyma. In certain of the Salsolæ, for example *Anabasis aphylla* L., the structure of the cortical parenchyma is slightly different.

**Thyllæ.†**—Dr. H. Molisch has investigated the phenomena connected with the formation of thyllæ in various tissues. They may occur in spiral, annular, or pitted vessels. In the first two cases the extremely thin wall of the vessel coalesces completely with the wall of the adjoining parenchymatous cell to form a homogeneous membrane which grows out into a thylla. In pitted vessels it is the closing membrane of the pit which grows out into the thylla. The remarkable growth of the membrane in all these cases appears to confirm the view of Wiesner that the growing cell-wall is permeated by protoplasm, and owes to it its power of growth. The thylla does not, as a rule, become shut off from the parenchymatous cell by a septum; they are therefore not themselves correctly described as cells. In a few cases they become sclerotized.

The number of genera in which thyllæ have at present been observed amounts to about 100. The greater number occur in the natural orders Marantaceæ, Musaceæ, Juglandæ, Urticaceæ, Moreæ, Artocarpeæ, Ulmaceæ, Anacardiaceæ, Vitaceæ, Cucurbitaceæ, and Aristolochiaceæ.

The most important function of thyllæ appears to be to serve as stoppers, and secondly as organs for the storing up of starch. The stomata become in some cases stopped by protrusions from the mesophyll-cells which project into the pore.

#### (4) Structure of Organs.

**Rooting of the Albumen of Cycas.‡**—M. P. Duchartre states that of the two parts which constitute the kernel of an adult albuminous seed, the one, the embryo, is essentially living and active, and susceptible of vegetating, while the other portion, the albumen, has been regarded until the present time as inactive and inert, and not susceptible of ulterior development. The author, however, has found that the seeds of *Cycas Thouarsii* R. Br., a great number of which often contain no embryo, can not only rupture the three zones of seminal integument, but can even form adventitious roots.

**Subterranean Shoots of Oxalis.§**—Mr. W. Trelease describes the underground shoots of *Oxalis violacea*. The watery tap-root is very strongly developed. From the withered bulb just above this protruded

\* Bull. Soc. Bot. France, xxxv. (1888) pp. 197-8.

† SB. K. Akad. Wiss. Wien, June 14, 1888. See Bot. Centralbl., xxxv. (1888) p. 222.

‡ Bull. Soc. Bot. France, xxxv. (1888) pp. 243-51.

§ Bot. Gazette, xiii. (1888) p. 191 (1 pl.).

from three to seven fleshy white runners, 1–2 mm. in diameter, and in some cases considerably over 2 in. long, with a few scales in the lower part, the rather acute apex somewhat enlarged, and crowded with scales, the inner ones very thick and yellow, forming the young bulb of next year. The runners appear to curve downwards at first, afterwards bending upwards at the apex.

**Torsion of Stems.\***—Herr R. Goethe gives particulars with regard to the twisting of the trunk of a number of trees. Many trees, as *Populus canadensis* and *alba*, appear never to exhibit torsion, while others, like the horse-chestnut, do so almost invariably. In the same species, or sometimes only in the same variety, the direction of the torsion is always constant; thus in the horse-chestnut it is always to the right, in the hornbeam to the left. Sometimes it does not manifest itself till the tree is 20 or 30 years old.

**Spines of certain Plants.†**—M. A. Lothelier states that numerous botanists have studied the spines of plants; but they have either exclusively noted the external morphology of the organs, or they have studied them from the point of view of their development. The anatomical study has been completely neglected. The author, in this paper, gives the results of some observations on this head.

If a section be made of the spine of *Ulex europæus*, from the middle to the apex, the pith appears thick and already sclerotized; round the pith are numerous fibrovascular bundles. A sclerenchymatous bundle alternates regularly with each of the fibrovascular bundles, usually corresponding to the number of ribs in the branch. In addition, radial collenchymatous bands situated opposite the fibrovascular bundles correspond to each of the ribs, and assist in sustaining the organ. The spines of *Cratægus oxyacantha*, as also those of *Genista hispanica*, *Lycium barbarum*, *Citrus triptera*, &c., have the morphological value of branches arrested in their development.

The author concludes with the following remarks:—(1) That in spines there is a reduction of the vessels from the base to the apex, with a gain in the sclerenchymatous elements; (2) The sustaining elements are furnished by the central cylinder, and especially by the strongly sclerotized pith. (3) All the tissues are differentiated. (4) In spinous branches the growth does not take place at the base, but at the apex.

**Protection of Buds.‡**—Herr A. Feist has investigated the various arrangements for the protection of the leaf-buds of dicotyledonous trees.

I. The protection of buds may consist of modified leaf-structures—

(a) The great majority of dicotyledonous trees have buds protected by special leaf-like structures of variable morphological nature, but in function exclusively protective. This is the case in *Quercus*, *Fagus*, *Populus*, *Ulmus*, *Carya alba* and *tomentosa*, *Tilia*, *Maackia*, *Laburnum*, *Actinidia*, *Cephalanthus*, *Ailanthus*. (b) Naked buds surrounded by leaves only are exhibited by *Pterocarya caucasica*, *Carya amara*, *Juglans nigra*, *Viburnum Lantana*, *V. Lentago*, *V. dentatum*, *Virgilia lutea*, *Rhus glabra*, *Ptelea mollis* and *trifoliata*, *Sophora japonica*, *Robinia viscosa*. In this case the buds not unfrequently require protection during development, and this is always afforded by various forms of hairs.

\* Gartenflora, xxxviii. (1888). See Bot. Ztg., xlvi. (1888) p. 450.

† Bull. Soc. Bot. France, xxxv. (1888) pp. 313–8.

‡ Nova Acta K. Leop.-Carol. Akad. Naturf., li. (1887) pp. 303–44 (2 pls.).

(c) In species of *Salix*, in *Viburnum Opulus* and *V. opulifolium*, the first pair of leaves grow together to form a completely inclosed protective sheath. (d) A similar sheath, morphologically referable however to the stipules, is exhibited by the buds of *Platanus* and *Magnoliaceæ*. This ochrea arises by true fusion of the stipules of aborted main leaves in *Platanus*, by apparent fusion in *Magnolia* and *Liriodendron*. (e) In stipulate plants the stipules usually share in the equipment of the buds. Exceptions are found in trees with very much reduced stipules, as *Euonymus*, *Ailanthus*, and *Viburnum Lantana*. In the species of *Alnus*, the protection is essentially restricted to the stipules of a developed main leaf of the daughter-bud. *Petteria ramentacea* exhibits another modification of stipular protection.

II. As a summer protection, some plants have utilized the leaf-base, which either incloses the axial bud like a cap, or covers it like a cushion. The first mode is seen in *Virgilia lutea*, *Rhus glabra*, *Robinia viscosa*, *R. hispida*, *R. Pseudacacia*, *Platanus*, and some of the *Philadelphaceæ*. The latter is exhibited in the species of *Gleditschia*, *Sophora japonica*, *Ptelea mollis* and *trifoliata*, *Menispermum canadense*, *Aristolochia siphon*, *Negundo aceroides*, *Calycanthus floridus* and *occidentalis*.

The separation of the subtending leaf takes place in *Robinia*, *Menispermum*, most *Philadelphaceæ*, and in *Gleditschia*, in such a way that the many-layered leaf-base covers the bud in winter.

An effective winter and summer protection is afforded in *Kalmia latifolia* and *Spartianthus junceus*, by a leaf-stalk which completely conceals the resting buds. In many plants (*Papilionaceæ*, *Amygdalaceæ*, *Rosaceæ*), the leaf when it falls leaves an articulation behind.

III. The bark may also function in preserving the buds. This protection may be a summer one, produced by the leaf-base, as in *Xanthoxylon Bungei*, *Sophora*, *Skimmia*, *Gleditschia*, *Phellodendron amurense*. When the cortical tissue protects the buds also during development, the modification occurs in very young stages when the subtending leaf is still in the hyponastic state. This is seen in *Actinidia colomieta* and *A. polygama*, *Cephalanthus occidentalis*, and *Gymnocladus canadensis*.

IV. Finally, the hairs furnish effective protection. They serve either to augment protective modifications of another nature, or they may by themselves discharge the greater part of this function. Hairy protections may be well seen in *Virgilia lutea*, *Gymnocladus*, *Viburnum Lentago*, *Pterocarya*, &c.

Development of the Flowers of the Mistletoe.\*—Herr L. Jost has minutely followed out the development of both male and female flowers in *Viscum album*, comparing it with what is known in other species belonging to the *Loranthaceæ*. The general results arrived at are that the organs of reproduction of both kinds are greatly reduced in structure. The ovules are reduced to single macrospores or embryo-sacs which are formed at the end of the axis of the flower; the anthers or microsporangia are not placed on special staminal leaves, but on the perianth. In their structure they bear a closer resemblance to those of some Vascular Cryptogams than to the andrœcium of most Angiosperms.

In the development of the female flowers, the mother-cells of the embryo-sacs are produced in considerable numbers, a common number

\* Bot. Ztg., xlv. (1888) pp. 357-68, 373-87 (1 pl.).

being seven; they do not appear to be formed in any regular order, and have no relationship to the two carpels. Only a small proportion of them develop into embryo-sacs capable of impregnation; in the specimens examined which were parasitic on *Populus laurifolia* and *Æsculus Pavia*, the number of embryos and embryo-sacs was always two or three, but it is stated to vary according to the species of the host.

The embryo-sac always consists in its early stage of two cells resulting from the transverse septation of a mother-cell; and, as in most other Phanerogams, the lower of these two cells alone develops into the embryo-sac, putting out a lateral protrusion which penetrates into the parenchyma of the ovary, and develops into the broad lower end of the sac. The upper of the two sister-cells does not, however, entirely disappear, as in most other flowering plants, and may possibly also sometimes develop into a fertile embryo-sac. This confirms Goebel's view that every daughter-cell of an archespore may potentially develop into an embryo-sac. In the mature embryo-sac are seen three antipodals with thick membranes, three bodies belonging to the egg-apparatus, and two central nuclei which afterwards unite into one.

The above description closely corresponds to that of Treub respecting *Viscum articulatum*, excepting that in the latter case the upper of the two sister-cells disappears altogether. In both species the embryo-sacs are developed from the hypodermal layer of cells of the end of the floral axis.

The male flowers of the mistletoe are much less common than the female. Here also it is the hypodermal layer of the anther from which the pollen-cells originate. In the course of their formation the epidermis undergoes irregular periclinal divisions, and ceases to exist as a special layer. The outermost layer of the archespore-cells develops into the tapetal cells, the inner layers undergo further increase of size, and become the mother-cells of the pollen. The mode of formation of the pollen in the mother-cells presents nothing special.

The great peculiarity of the male flowers of *Viscum*, viz. the direct formation of the anther on the perianth, and not in connection with a special staminal leaf or stamen, appears to belong exclusively to the Loranthaceæ; but, within this order, occurs also in *Arceuthobium*, and apparently also in the very rare *Castræa falcata*.

*Arceuthobium*.\*—Mr. T. Johnson has carefully followed out the embryogeny of this genus of Loranthaceæ, especially of *A. Oxycedri*. The following is a summary of the results.

There is formed in the ovary, at the time of pollination, a conical papilla projecting free from its base, containing two embryo-sacs imbedded at the side of the apex, in which the contents are arranged as in a normal angiosperm. The embryo-sacs arise in each case from a single hypodermal archespore-cell. The morphological value of the contents of the ovary is the same as in *Loranthus sphærocarpus*, as described by Treub,† the papilla consisting of the modified apex of the floral axis, and constituting a placenta bearing two buried ovules reduced to embryo-sacs. At no time does the papilla fuse with the wall of the ovary; its apical region becomes a pseudo-calyptra to the solitary embryo, which is straight, and has an exerted radicle without a root-cap. The dehiscence of the fruit is finally due to the rupture of a basal horizontal merismatic

\* Ann. of Bot., ii. (1888) pp. 137-60 (1 pl.).

† See this Journal, 1882, p. 363.

zone. The seed is covered by the endocarp, the most external layer of which consists of viscid cells, which are severed at their peripheral (distal) ends when the seed is ejected. Neither the sessile anthers nor the carpels are vascular; the latter are opposite to the segments of the perianth. The author found no adventitious purely vegetative shoots; he detected a constant connection of the xylem-vessels of the parasite with the tracheides of the host (*Pinus* or *Juniperus*), and a cleavage of the radial wall of the tracheide of the host by the finest haustoria of the parasite.

**Seeds with Two Integuments.\***—M. H. Jumelle states that the integuments of seeds do not generally coincide with those of the ovule. When the seed has two integuments, these integuments are formed from the external envelope of the ovule, the internal one disappearing. This rule, to which up to the present time the Euphorbiaceæ have been considered an exception, is not however absolute; the author pointing out two other groups which form exceptions. These groups are Rosaceæ and Rutaceæ, in both of which, as in Euphorbiaceæ, the two integuments of the ovule persist. In this case these two integuments are separated by the formation of a layer of cork in the region of the chalaza, where they were previously in contact.

**Overlooked Function of many Fruits.†**—Prof. C. E. Bessey points out that the green colour of the rind of many fruits is not an original condition, but that the colour makes its appearance during their increase in size. He suggests that this very general development of chlorophyllous tissue is for the nutrition of the embryo in the seed. A striking instance is afforded by many species of elm in which, at the time of flowering, there are no leaves upon the tree, nor do any appear until the fruits are fully grown.

**Trapella, Oliv., a new Genus of Pedalineæ.‡**—Dr. F. W. Oliver describes the structure, development, and affinities of *Trapella* Oliv., a new genus of Pedalineæ, the single known species, *T. sinensis*, growing in China.

*Trapella* is an aquatic plant with long straggling and simple or sparingly branched stems, which ascend obliquely through, and float on the surface of the water. In the axils of the floating leaves, and of the submerged ones for some distance below the surface, flowers are formed, which in the former case open just above the surface, but in the latter are cleistogamic. The ovary is bilocular, but the anterior loculus is quite rudimentary. The placentation is axile, and the two ovules are inserted high up in the fore-part of the ovary. Both are pendulous, and apparently anatropous, with superior micropyle. They are attached right and left of the median line to the top of the partition separating the reduced and fully developed loculi. The upper ovule, attached on the right side of the median line, is sessile, but the lower one is suspended by a longish funicle.

In the youngest buds the author was able to investigate, all the organs were already formed. Up to a certain point the developmental history of both upper and lower ovules is identical; since, however, in

\* Bull. Soc. Bot. France, xxxv. (1888) pp. 302-4.

† Amer. Natural., xxii. (1888) p. 531.

‡ Ann. of Bot., ii. (1888) pp. 75-112 (5 pls. and 1 fig.).

all cases it is the upper one only which becomes a seed, this only is described.

The author then describes in detail the development of ovule and embryo-sac both before and after fertilization. The cell which is cut off from the archesporial cell does not lie, as is usual, at the micropylar, but at the opposite end of the embryo-sac mother-cell; and another most anomalous appearance is to be seen at the base of the embryo-sac after fertilization. The lowest cap-cell elongates until it has considerably outstripped the embryo-sac in length; further, it becomes divided by a longitudinal median wall into symmetrical halves. The "appendage," as the author denotes this structure, consists therefore of two very long tapering cells, applied side by side, and ensheathed in the down-growing ovular tissue.

In the earlier stages after fertilization no formation of endosperm takes place in the micropylar region of the embryo-sac. This region is occupied by the synergidæ, which, instead of dwindling after fertilization in the usual manner, go on increasing in bulk. By the time the seed is ripe, they have become so large as to constitute a conspicuous tubercle at the top of the seed. They have a granular protoplasm, often highly vacuolated, and each has a large nucleus. Dr. Oliver suggests that these enlarged synergidæ assist in the absorption of the food-material for the placenta.

In *Trapella* the cap-cells normally all lie below, i. e. at the chalazal end of the embryo-sac, and not at its micropylar end. It is the uppermost cell of the row which becomes the embryo-sac; a structure almost unique among known plants. The author points out analogies in some respects in the development of the embryo-sac in *Loranthus*, *Asarum*, and *Crocus*, but in no other case do we meet with a persistent enlarged cap-cell, as in *Trapella*.

As to the affinities of *Trapella*: though coming in touch with Myoporinæ in the form and arrangement of the seeds, it is separated therefrom by its eminently pedalinaceous fruit and opposite leaves. None the less *Trapella* forms a connecting link between the two somewhat artificially separated cohorts of the "Genera Plantarum," namely the *Personales* and *Lamiales*; Pedalinæ being placed with the former, Myoporinæ with the latter. *Trapella* must, however, rest in Pedalinæ, forming the only genus in a new tribe *Trapelleæ*.

### β. Physiology.\*

#### (1) Reproduction and Germination.

Cross-fertilization.†—Mr. A. G. Foerste describes the structure of the flowers of the following American species in connection with their adaptation for cross-fertilization by insects:—*Silene pennsylvanica* and *regia*, *Sabbatia angularis*, *Psoralea Onobrychis*, *Desmodium canescens*, *Lespedeza violacea*, *Tecoma radicans*, *Mimulus alatus* and *ringens*, *Scrophularia nodosa*, *Ruellia strepens*, *Pycnanthemum lanceolatum*, *Monarda fistulosa*, *Brunella vulgaris*, and *Stachys cordata*.

\* This subdivision contains (1) Reproduction and Germination; (2) Nutrition and Growth (including Movements of Fluids); (3) Irritability; and (4) Chemical Changes (including Respiration and Fermentation).

† Bot. Gazette, xiii. (1888) pp. 151-6 (1 pl.).

**Self-fertilization and Cleistogamy in Orchids.\***—Mr. H. N. Ridley points out four common methods of self-fertilization among orchids:—(1) By breaking up of the pollen-mass and the falling of the pollen, either directly upon the stigma or into the labellum, whence it comes into contact with the stigma. This, of course, can only happen in the case of orchids with pulverulent pollen. (2) By the falling of the pollen-masses as a whole from the clinandrium into the stigma. This is probably not rare, but the author has met with records of but few examples. (3) By the falling forward of the pollinia from the clinandrium or the anther-cap, the caudicle and gland remaining attached to the column. (4) By flooding of the stigma. The pollen-masses remain in the anther-cap or on the clinandrium, while the stigma exudes so great a quantity of stigmatic fluid that it eventually reaches the edge of the pollinia, which immediately emit pollen-tubes. This seems to be the commonest method of self-fertilization.

**Self-pollination of *Spergularia salina*.†**—While this species from Egypt and the oases of the Libyan desert is described as having open flowers with pink petals, Herr P. Magnus finds it at Kissingen cleistogamous and usually with only three stamens. The apetalous condition and reduction in the number of stamens he believes to be a hereditary peculiarity in certain localities due to the continued absence of any means of pollination.

**Fertilization of *Cattleya labiata*.‡**—Mr. H. J. Veitch deduces the following general statements from a series of observations he has made on the fertilization of *Cattleya labiata*:—The impregnation of the ovules of *Cattleya labiata* var. *Mossiae*, under glass in the climate of London, takes place from 75–90 days after the pollination of the flower, the length of time being doubtless influenced by the state of the weather during the interval, and especially by the amount of direct sunlight the plants receive; the more direct sunlight, the shorter the interval, and *vice versa*. A proportion of the ovules only are fertilized; but how great that proportion is it is not possible to determine with certainty; it is never probably much less than one-half; it probably varies from a little less to a little more than one-half. It is certain also that of the seeds which are mature and good, a greater or less proportion of them failed to germinate under artificial conditions. It takes about twelve months, under the same conditions, to effect the maturation of the capsules; it being highly probable that during the winter months, when the temperature in which the plants are kept is comparatively low, and the amount of direct sunlight and sunheat is at the minimum, there is a cessation of growth which is renewed as the summer months are approached.

(2) Nutrition and Growth (including Movements of Fluids).

**Daily Assimilation of Carbohydrates.§**—From the results of a number of experiments on the chemical composition of leaves in the

\* Journ. Linn. Soc. (Bot.), xxiv. (1888) pp. 339–94 (1 pl.).

† SB. Gesell. Naturf. Freunde Berlin, Feb. 28, 1888. See Bot. Centralbl., xxxv. (1888) p. 5.

‡ Journ. Linn. Soc. (Bot.), xxiv. (1888) pp. 395–406 (14 figs.).

§ 'Zur Kenntniss d. tägl. Assimilation der Kohlehydrate,' Halle, 1887. See Bot. Ztg., xlv. (1888) p. 465.

ordinary air and in an atmosphere devoid of carbon dioxide, Herr O. Menze draws the following conclusions:—The dry weight of leaves increases by day when assimilation is unchecked; and this increase in dry weight is due to the increase in the amount of assimilated starch. In cut leaves the amount of sugar increases in the light, in consequence of the absorption of starch. When leaves are exposed in light to an atmosphere containing no carbon dioxide, they decrease in dry weight from loss of starch, which is indicated by an increase in the amount of soluble carbohydrates.

**Action of Light on Roots grown in Water.\***—M. Devaux gives the results of some experiments he has made on the action of light on roots grown in water. When exposed to light the growth of roots in water is far less than when left in darkness; hairs, however, are more abundant. The ramification of roots exposed to light is feeble, while if left in darkness branches are quickly and abundantly formed. The pigmentation, however, of roots exposed to light is strong, while in darkness it is weak.

**Influence of Radiant Heat on the Development of the Flower.†**—Herr H. Vöchting has shown, by placing between the source of light and an opening bud of *Magnolia conspicua* a solution of iodine in carbon bisulphide, which has the power of completely absorbing the illuminating rays of the spectrum, while allowing the dark heat-rays to pass, that the curvature attendant on growth takes place just as in normal sunlight. It must therefore be the non-illuminating rays to which the growth is due.

### (3) Irritability.

**Electromotive Properties of the Leaf of *Dionæa*.‡**—Prof. J. Burdon Sanderson has continued his investigations into the electromotive properties of the leaf of *Dionæa* in the excited and unexcited states. They confirm his previous conclusion, that the property by virtue of which the excitable structures of the leaf respond to stimulation is of the same nature as that possessed by the similarly endowed structures of animals. He finds the two sets of phenomena termed those of the resting-current and those of the action-current of the leaf—i. e. the electrical properties possessed by the leaf when stimulated and those which it displays when at rest—so linked together that every change in the state of leaf when at rest conditionates a corresponding change in the way in which it reacts to stimulation; the correspondence consisting in this, that the direction of the response is opposed to that of the previous difference of potential between the opposite surfaces, so that as the latter changes from ascending to descending, the former changes from descending to ascending.

The author considers that this can only be understood to mean that the constantly operative electromotive forces which find their expression in the persistent difference of potential between the opposite surfaces, and those more transitory ones which are called into momentary existence by touching the sensitive filaments or by other modes of stimulation, have the same seat, and that the opposition between them is in

\* Bull. Soc. Bot. France, xxxv. (1888) pp. 305-8.

† Ber. Deutsch. Bot. Gesell., vi. (1888) pp. 167-78 (1 pl.).

‡ Proc. Roy. Soc., xlv. (1888) pp. 202-4. Cf. this Journal, 1882, p. 533.

accordance with a principle applicable in common to the excitable structures of plants and animals, viz. that the property which renders a structure capable of undergoing excitatory change is expressed by relative positivity, the condition of discharge by relative negativity.

All these changes depend, in the author's opinion, on a difference of physiological activity between adjacent excitable cells or strata of cells of which the protoplasmic linings are in continuity.

**Case of Abolition of Geotropism.\***—M. P. Duchartre observed that, out of a dozen seeds of *Phaseolus multiflorus* sown at the same time, the germination of one was very abnormal. At the end of several days a small body was seen to project from this seed above the soil. This body elongated vertically; then, upon four equidistant longitudinal lines, small protuberances were formed. The author then recognized it to be the radicle of the embryo. He allowed it to grow for about two months, and then examined it anatemically, an account of which is included in the paper.

**Studies in Vegetable Biology.†**—Mr. S. Le M. Moore continues his observations on the influence of light upon protoplasmic movement. After making various experiments with *Selaginella Martensii* and other plants, the author states that we are justified in concluding that intense light and prolonged darkness act in precisely the same manner upon chlorophyll-bodies; and it appears also that, paradoxical though it may sound, fragmentation and condensation are really the same phenomenon, the only difference between them being that in the former condensation is more violent along certain lines than along others, thus entailing disruption, whereas in the latter it proceeds equally all round.

The author then makes some further observations on photolysis. In those epidermal cells which are well provided with apparently healthy chlorophyll without starchy contents, the deficient factor is protoplasmic energy; and if this be correct, the failure of photolysis to come off in epidermal issues is easily understood. At any rate, it is submitted that, in view of its inability to stand the crucial test here applied to it, the "activity" doctrine should henceforth be dismissed from vegetable physiology.

The author then makes some observations on the behaviour of the chlorophyll-plate of *Mesocarpus* with regard to light. (1) In diffused light the chlorophyll-plate of *Mesocarpus* sets itself so as to cut the greatest number of light-rays of the highest intensity. (2) In weak sunlight the plate turns edge up. (3) The plate can be negatively apostrophized. (4) When the turning movement is in progress, it will not be stopped in the dark if light have imparted sufficient impetus to the plate. (5) In darkness the plate may turn so as to remain either face up or on its edge.

He then goes on to discuss the lateral position of the chlorophyll of palisade-cells. The capacity of light to modify the form of palisade-cells is admitted on all hands. This granted, what difficulty is there in conceiving that the form of all cells in direct relation with light is so ordained by this agency, as to insure, upon simple mechanical principles, the maximum exposure of the protoplasm to favourable, and its minimum exposure to unfavourable (positive) grades of illumination?

\* Bull. Soc. Bot. France, xxxv. (1888) pp. 266-71.

† Journ. Linn. Soc. (Bot.), xxiv. (1888) pp. 351-86 (3 pls.).

## (4) Chemical Changes (including Respiration and Fermentation).

**Function of the Colouring Matter of Chlorophyll.\***—Prof. A. Hansen states, that like the colouring matter of blood, the absorption-bands of chlorophyll have no connection with the assimilative power of the same. The colouring matter absorbs carbonic anhydride, and forms with it an unstable compound, which passes on the carbonic anhydride to the plasma of the chlorophyll-grains. Chlorophyllous cells absorb more and more gas as the temperature rises, consequently the law of diffusion and absorption of gases is not followed in this case; but the absorption is dependent on atmospheric pressure.

**Diastase.†**—Herr J. Fankhauser states that during the germination of barley, the development of the plumule is accompanied by the destruction and solution of the cell-walls in the grain. This solution may be due either to a substance formed by the embryo, namely diastase, or to micro-organisms. A microscopical examination, however, failed to show the presence of the latter.

Experiments showed that during the germination both of potatoes and of barley, the evolution of carbonic anhydride is accompanied by the secretion of one or of several powerful acids. Malt treated with 5 per cent. solution of potash yielded an extract, which, after suitable treatment, gave a distillate, in which formic acid was the chief constituent. It was found that both this distillate, and also commercial formic acid, had the power of changing a carbohydrate into sugar.

The author believes that the cell-walls of the starch-granules which are in direct contact with the plumule are attacked by the formic acid it secretes, and that in the course of brewing, the formic acid acts on the starch just as dilute sulphuric acid would. He also attributes the sweetness that potatoes acquire to a similar cause; formic and probably other allied acids, are formed during the respiratory process that accompanies sprouting, and these acids attack the cell-walls and also change the starch into sugar. Many other phenomena of plant growth can be explained by this secretion of strong acids by organs containing no chlorophyll, for instance, the piercing of wood by the mycelia of fungi.

**Substance containing Sulphur in Cruciferous Plants.‡**—Mr. J. Smith states that in the animal body the substances which contain sulphur are, with one exception, exclusively proteid or derived from proteids. In plants, on the other hand, numerous sulphur-containing substances are found. The amount of uncombined and of combined sulphuric acid was estimated in the seeds of nineteen varieties of Crucifers; the former occurs either not at all, or in mere traces, except in *Isatis tinctoria*, and here it is probably in the shell of the seed. The ethereal hydrogen sulphates were found abundantly in all, but especially in the seeds of *Sinapis nigra*. In this form of mustard seed, about one-third of the total sulphur is combined as proteid, the remaining two-thirds as myronic acid.

\* Bied. Centr., 1888, pp. 357-8. See Journ. Chem. Soc., 1888, Abstr., p. 867.

† Bied. Centr., 1888, pp. 205-7. See Journ. Chem. Soc., 1888, Abstr., p. 867.

‡ Zeitschr. Physiol. Chem., xii. pp. 419-33. See Journ. Chem. Soc., 1888, Abstr., p. 869.

## γ. General.

**Myrmecophilous Plants.\***—M. M. Treub adduces fresh evidence in favour of his theory that the passages inhabited by ants in the stem of *Myrmecodia tuberosa* (previously described as *M. echinata*) have for their primary function to serve as reservoirs of water to prevent desiccation, and only secondarily become the abode of ants, which may possibly then be of some service to the plant; though he finds them to flourish equally when not visited by ants. The passages are developed in the hypocotyl of the seedling at the very earliest period, before it can possibly be visited by insects. The author adduces a number of examples of a similar protection against desiccation, where there is no question of the water-receptacles being due to the attacks of ants.

**Myrmecophilous Plants.†**—Prof. F. Delpino continues his observations on those plants which attract the visits of ants by extra-floral nectaries. In the order Bignoniaceæ they are especially numerous, amounting to about 66 per cent. of the total number of species in the order. They occur chiefly on the upper or under side of the leaf.

In the Pedalineeæ 13 out of 28 species have extra-floral nectaries. In the Convolvulaceæ a few species only are named. In the Verbenaceæ there are all grades, from the entire absence of such organs to their very elaborate development in *Clerodendron*. In this genus there are 24 myrmecophilous species; in *Citharoxylum* 12. In Scrophularineæ, *Melanopyrum* is a myrmecophilous genus. In Polygonaceæ only very few species are named. In the Euphorbiaceæ there are 56 myrmecophilous species in the Crotonaceæ, 20 each in the Acalyphaceæ and Hippomaneæ, 2 in the Euphorbiaceæ, none in the remaining tribes. In the Salicineæ and Orchideæ a few species are enumerated. In the Liliaceæ many species of *Lilium* have extra-floral nectaries; in the Smilacaceæ there are about 95 species; a few in the Dioscoreaceæ, Hæmodoraceæ, and Irideæ; about 30 in the Musaceæ, and a few among Palmæ.

Among Filices *Pteris aquilina* has nectaries at the base of the frond. Among Fungi the honey-secreting spermogonia of the Uredineæ appear to attract flies rather than ants. Ustilagineæ also protect the leaves of the host-plant by attracting ants, and thus preventing their being browsed by animals.

**New Myrmecophilous Plants.‡**—Herr K. Schumann describes in great detail the structure of several hitherto undescribed myrmecophilous plants, mostly from tropical South America, belonging to the Melastomaceæ.

*Duroia hirsuta* (*Amajona hirsuta* P. and E.) is a small tree in which the provision for the inhabiting ants is in the form of a chamber in the main stem, contained in a large swelling, of very complicated and perfect structure. Other species described are *Cuviera physinodes*, belonging to the Rubiaceæ, *Pleurothyrium macranthum* (Lauraceæ), *Calophysca tocoicoidea*, *Maiaca Guianensis* and *flexuosa*, and *Tococa lancifolia* and *macrophysca*.

*Duroia saccifera*, as well as *D. hirsuta*, possesses also another con-

\* Ann. Jard. Bot. Buitenzorg, vii. (1888) pp. 191-213 (3 pls.). See Bot. Centralbl., xxxv. (1888) p. 295. Cf. this Journal, 1884, p. 81.

† Mem. R. Accad. Sci. Istit. Bologna, viii. (1888) pp. 601-50. See Bot. Centralbl., xxxv. (1888) p. 233. Cf. this Journal, 1887, p. 620.

‡ Pringsheim's Jahrb. f. Wiss. Bot., xix. (1888) pp. 357-421 (2 pls.).

trivance for the lodging of ants, in the form of bladders on the leaf-stalk or upper surface of the leaf.

The author concludes with a classification of the various contrivances for the accommodation of ants, which he divides in the first place into axial cavities, and chambers connected with the leaves.

**Comparative Cultures of the same species at different altitudes.\***—M. G. Bonnier has undertaken the culture of a certain number of species at different altitudes in the Alps and Pyrenees. In all cases certain plants were sown, while others were planted. When a sowing was to be made, the packet of seeds was divided into three lots, one was sown at a high altitude, another at a medium altitude, and the third at Paris. The author found that the plants he experimented with were very unequally affected by this change in their external physical conditions. Thus *Thymus Serpyllum*, for instance, changed much less in aspect than *Lotus corniculatus* or *Leontodon autumnalis*. It may be laid down as a general rule that annuals or biennials are much less modified than perennials. The author then compares *Teucrium Scorodonia* grown at high altitudes in the Pyrenees with that grown in Paris. In the former case the plants produced very short aerial stems, with deep green hairy leaves, while in the latter case the stems were much longer, the green of the leaf much lighter, and hairs less numerous.

## B. CRYPTOGAMIA.

### Cryptogamia Vascularia.

**Antherozoids of *Cheilanthes hirta*.†**—M. Leclerc du Sablon has carefully followed out the mode of formation of the antherozoids in this fern. In the way in which the mother-cells of the antherozoids are formed, there is no essential difference from that described by Strasburger in the case of *Polystichum aculeatum*. When the antherozoid is about to be formed, the nucleus of the mother-cell becomes first eccentric; then a portion of the protoplasm forms a hyaline ring round the cell in contact with the nucleus; the nucleus then elongates itself to the length of this ring, and forms the body of the antherozoid; the greater part of the hyaline ring is employed in the formation of the cilia; the rest forms the thin protoplasmic envelope of the antherozoid. This vesicle plays no essential part in the process of impregnation.

**Apogamy in *Notochlæna*.‡**—Prof. S. Berggren records an additional instance of apogamy among ferns, in the case of *Notochlæna distans* from New Zealand, which differs in some respects from the well-known example of *Pteris cretica*. From the anterior incision in the prothallium there proceeds a ligulate lobe, usually unilamellar, but sometimes composed of several layers of cells. This may again produce a similar lobe at its apex. As the central lobe possesses a fibrovascular bundle, it may be regarded as an intermediate structure between an ordinary prothallium and the first leaf of a young fern. Near the apex of the central lobe a papilla-like swelling is formed by cell-division, which develops into the rudiment of the first leaf of the young shoot. Between it and the margin of the central lobe is the apex of the young stem; the second leaf is formed at the opposite side of the apex, and at a later period the first root.

\* Bull. Soc. Bot. France, xxxiv. (1888) pp. 467-9. † Ibid., xxxv. pp. 238-42.

‡ Bot. Notiser, 1888, pp. 14-6 (1 fig.). See Bot. Centralbl., xxxv. (1888) p. 183.

**Dissemination of the Spores of Equisetum.\***—According to Mr. F. C. Newcombe, there are three factors in the mechanism for the dissemination of the spores of *Equisetum (arvense)*:—(1) The somewhat sudden lengthening of the axis of the spike immediately before ripening, due to the elongation of the cells of which it is composed, by which the sporangia are pushed apart. (2) The unequal contraction in length and width of the strong external layer of cells of the sporangium-wall. In this layer are both annular and spiral cells. (3) The action of the elaters, which is twofold; first, the ejection of the spores from the sporangium, which is brought about by the unequal hygroscopic properties of the two layers of cells of which the elaters are composed; and secondly, the facility for carriage by the wind afforded by their broad spatulate extremities.

#### Muscineæ.

**Peristome.†**—M. Philibert in this paper concludes his observations on the internal peristome of mosses and its variations. The Fontinalaceæ, including *Dichelyma*, ought to be included among the Hypnobryaceæ, while the genera *Cinclidotus* and *Scouleria* belong, on the contrary, to the Aplolepideæ. In *Scouleria aquatica* the peristome is remarkable; it is composed of thirty-two large linear obtuse teeth, and approaches the structure of that of *Grimmia*, while the peristome of *Cinclidotus* has more analogy with that of *Barbula*.

After describing the Timmiaceæ in some detail, the author states that this type may be considered as belonging to the Hypnobryaceæ, as the basilar membrane and teeth preserve exactly the same structure. The difference, however, becomes much more marked in the Funariaceæ, the primitive plan of the peristome in this family being much the same as in the Bryaceæ. The plates and lamellæ of the teeth are disposed in exactly the same manner. The dorsal network of the internal peristome is made up of a series of rectangles which are opposed to the ventral plates of the teeth, and the ventral network is made up of two rows of trapezes placed opposite to each tooth.

The author, in conclusion, states that the simple peristome of the Aplolepideæ has more analogy in its structure with the internal peristome of the Diplolepideæ than with their external peristome. In order to explain the origin of the Aplolepideæ, it is only necessary to suppose that, in an analogous structure to that of *Funaria*, the exterior teeth being wanting, the internal peristome then remained, and this latter in course of time took upon itself a much more varied and larger development.

**Development of the Sporogonium of Andreaea and Sphagnum.‡**—Dr. M. Waldner has carefully followed the development of the sporogonium in these two genera of mosses. In *Andreaea* he finds that, as is the case in the typical forms of mosses, the spore-forming layer originates in the layers of cells at the base of the sporogonium. The wedge-shaped apical cell forms, by apical growth, from eleven to thirteen segments, and the formation of the sporogenous layer begins in the third oldest segment. In *Sphagnum*, on the other hand, the first rudiment of the

\* Bot. Gazette, xiii. (1888) pp. 173-8 (1 pl.).

† Rev. Bryol., xv. (1888) pp. 50-60, 65-9. Cf. this Journal, ante, p. 620.

‡ 'Die Entwickl. d. Sporogone v. *Andreaea* u. *Sphagnum*,' Leipzig, 1887. See Oesterr. Bot. Zeitschr., xxxviii. (1888) p. 281. Cf. this Journal, 1880, p. 122.

sporogonium, formed by apical growth, consists of only from six to eight segments, and the sporogenous layer does not spring from the basal but from the parietal layer, the uppermost three layers and the apical cell take part in its formation.

**Hygroscopic Movements of the Thallus of Marchantieæ.\***—Dr. O. Mattirollo finds the thallus of certain Marchantieæ to be remarkably sensitive to hygroscopic influences. The observations were made chiefly on species belonging to the genera *Plagiochasma*, *Reboulia*, *Grimaldia*, *Fimbriaria*, and *Targionia*.

Taking *Grimaldia dichotoma* as an example, the flat thallus consists of three distinct layers of tissue, viz. (1) the epidermal layer, perforated with stomata; (2) the assimilating layer, consisting of rows of chlorophyllous cells at right angles to the surface, between which are large air-chambers; and (3) the mechanical layer, composed of closely-packed spherical or polyhedral cells without intercellular spaces, containing a certain amount of chlorophyll, starch-grains, and oily substances. The whole is attached to the soil by rhizoids, and its under surface covered with brown or dark violet scales.

The seat of the movements is in the mechanical layer, the cells of which are remarkably hygroscopic, more than doubling in size on absorption of water. To such an extent does the thallus shrink up on desiccation that it seems almost to disappear; but it has the power of retaining its vitality in this condition for a very long period (certainly as much as thirteen months), swelling and resuming its normal appearance when again moistened. The movements are entirely independent of light or darkness, and are produced solely by changes in the moisture of the air. When the air is dry, the thallus folds itself up, the free margins rising and bending over, so that the ventral scaly surface completely covers the whole thallus, concealing the stomata, and protecting it from further desiccation and from injury from changes of temperature.

The cells of the mechanical layer were very frequently found to be occupied by *Nostoc* colonies.

#### Characeæ.

**New Chara.†**—Dr. O. Nordstedt describes a new species of *Chara* from Australia, belonging to the section *Euchara*. Its diagnosis he gives thus:—*Ch. haplostephana*, *bistipulata*, *haplostiche*, *corticata*, *gymnophylla*, *dioica*. The leaves are in whorls of from 7 to 10, with 2 to 4 antheridia in the secondary whorls of the male plant; the diameter of the stem is from 0·2 to 0·4 mm.; the leaves 0·15, the secondary leaves 0·12 mm.; the antheridia 0·45 to 0·60 mm.; the nucleus of the sporangium black, with seven spirals, from 0·42 to 0·52 mm. long and 0·30 to 0·35 mm. broad.

**New Nitella.‡**—Dr. O. Nordstedt describes a remarkable new species of *Nitella*, which he calls *N. dualis*, obtained from Liberia among the results of the "Gazelle" Expedition. It has unusually long slender internodes, and the secondary and tertiary branches are densely clustered, so as to give it a very beautiful appearance.

\* Malpighia, ii. (1888) pp. 181–223 (2 pls.).

† Hedwigia, xxvii. (1888) p. 189 (1 pl.).

‡ Forschungsreise S.M.S. Gazelle, part iv. [Bot.], Characeæ, 2 pp. and 1 pl.

## Algæ.

**New Genera of Florideæ.\***—Herr P. F. Reinsch describes a number of new species of Florideæ from the island of S. Georgia, together with the following three new genera:—*Chroa*, a genus of Chordariaceæ, with an entire vesicular frond without dissepiments, near to *Chordaria*; *Merenia*, a genus of Rhodomelaceæ, with filamentous monosiphonous frond, and transversely septate stichidia, intermediate between *Poly-siphonia* and *Dasya*; and *Straggaria*, an epiphytic genus, of which the fructification is unknown, forming subconvex tubercles on *Almfeltia plicata*, the exact position of which is at present undetermined.

**Zygospores of Conjugatæ.†**—Herr H. Klebahn has followed out closely the history of the nuclei of the two cells which unite to form the zygote of the Conjugatæ; he finds it to differ in some cases from the process as described by Schmitz and Strasburger. In several species of *Spirogyra* there are in the young zygospore still two distinct nuclei, each with its own nucleolus. In this state it may remain some days before the complete fusion of the nuclei. In the species of *Zygnema* examined the complete coalescence of the nuclei appeared to take place much more rapidly. Among the Desmidiæ, he obtained in *Closterium (lunula)* the remarkable result that even in the ripe zygote the two nuclei still remained perfectly distinct. In another genus of desmids, *Cylindrocystis (Brebissonii)*, the process more closely resembled that in *Zygnema*. In the young zygospore was found a single nucleus, but usually with two nucleoli.

**Spongocladia.‡**—Messrs. G. Murray and L. A. Boodle discuss the systematic position of this genus of Areschoug's, referred by him to the Siphonæ, with which they identify *Spongodendron* Zanard. They regard these algæ as probably more nearly allied to *Cladophora* than to the Siphonæ, though closely resembling some genera of that family, especially *Codium*, in external appearance. The thallus of *S. vaucherix-formis* Aresch. consists of long filiform tubes so interwoven as to form a number of irregularly dichotomous branches, the whole recalling the appearance of a digitate sponge. The tubes of which the branches are composed are septate below, and short lateral branches are given off at about a right angle from the cells. These serve to bind more closely together the interwoven filaments. A probable formation of zoospores was observed, which appear to germinate within the mother-cell.

A remarkable feature of these algæ is the groups of siliceous spicules which plentifully strew the course of the tubes. They are obviously sponge-spicules, and are far more abundant than is consistent with a merely accidental presence. Those found in connection with the different species belong to the different sponges; and the authors suggest that there may possibly be some biological relationship of a symbiotic character between the sponge and the alga.

**Aerophytic Species of Ulotrichaceæ.§**—Dr. A. Hansgirg gives a synopsis of the known species of the genera *Hormidium*, *Hormiscia*, and *Schizogonium*, which he treats as belonging to the Ulotrichaceæ. He

\* Ber. Deutsch. Bot. Gesell., vi. (1888) pp. 144-56. † Ibid., pp. 160-6 (1 pl.).

‡ Ann. of Bot., ii. (1888) pp. 169-75 (4 figs.).

§ Flora, lxxi. (1888) pp. 259-66. Cf. this Journal, ante, pp. 465 and 775.

restates his previous view that the so-called genera *Schizogonium*, *Hormidium*, and *Prasiola*, are but stages in the development of the same organism, there being an unbroken chain of intermediate forms between them. The species of *Hormidium* are to be distinguished from those of *Hormiscia* or *Ulothrix* proper by the form of their chromatophores. Those of *Schizogonium* and *Prasiola* resemble those of *Hormidium*.

**Structure of Ulothrix.**\*—Herr G. Istvánffi describes several points in the structure and details of *Ulothrix zonata*. The rhizoids, for which he prefers the term haptera, he finds, after a time, lose their contents, and then serve the purpose simply of mechanical cells. They exhibit peculiar phenomena of proliferation, and almost invariably branch dichotomously.

Some of the cells are subject to a peculiar hypertrophy, swelling up to fifteen or even twenty-five times the length of the ordinary vegetative cells; they are endowed with life, and are frequently divided up into smaller cells; they contain a number of nuclei.

The cells of *Ulothrix* always contain a nucleus which is visible without special treatment. The chlorophores are stretched and ruptured by the rapid growth of the vegetative cells; they can, within a short period, assume various forms and display a variety of movements.

**Bulbotrichia.**—M. É. de Wildeman † proposes the suppression of the genus *Bulbotrichia* Ktz., which he regards not as an independent genus of algæ, but as being of a lichenoid nature, consisting of gonidia allied to *Protococcus*, which are beginning to be invaded by filaments of a parasitic fungus, in fact, as a lichen in process of construction. In this opinion Dr. J. B. de Toni ‡ agrees.

**Hansgirgia**, a new genus of aerial Algæ.§—Dr. J. B. de Toni describes an epiphytic alga found on the leaves of *Anthurium Scherzianum* in the botanic garden at Padua, which he establishes as the type of a new genus *Hansgirgia* (*flabelligera*), belonging to the Trentepohliaceæ, but distinguished from the other known genera of the family by the green colour being masked by the presence of chlororufin or hæmatochrome in the cells. The vegetative structure consists of a mass of chroolepidiform branched and anastomosing filaments; these are in parts distinct, forming a network, in parts more or less united laterally into imperfect discs having the form of a fan. The chlorophores are parietal, concealed by the orange-yellow pigment, which occurs in the form of globules, and is turned violet or nearly black by zinc chloriodide. The reticulate filaments produce ovoid zoosporanges containing biciliated zoospores; their germination has not been observed, nor any conjugation between them. He proposes from it the establishment of a sub-family, *Hansgirgiæ*, connecting the two other sub-families of Trentepohliaceæ, viz. *Chroolepideæ* and *Mycoidæ*.

**Chlorogonium.** ||—*Chlorogonium euchlorum* Ehrb., placed by Ehrenberg and Stein among the Flagellate Infusoria, has been carefully examined by M. P. A. Dangeard, who considers it to belong to the Volvocineæ, and to come very near to *Chlamydomonas*. It has both a

\* MT. Med.-Naturw. Classe Siebenbürg. Mus.-Vereins, xiii. (1888) pp. 53-66 (1 pl.). See Bot. Centralbl., xxxv. (1888) p. 122.

† CR. Soc. R. Bot. Belg., 1888, pp. 157-9.

‡ Loc. cit., p. 157.

§ Ibid., pp. 154-7, and Notarisia, iii. (1888) pp. 581-4.

|| Bull. Soc. Linn. Normandie, i. 1886-7 (1888) pp. 160-4.

sexual and a non-sexual mode of reproduction; the latter by zoospores, the former by zoogametes, which resemble the zoospores but are smaller. The process is exceedingly similar to that in *Chlamydomonas Reinhardti* Dang.

*Chlamydomonas*.\*—M. P. A. Dangeard gives a review of the species belonging to this genus, which amount to four, two of them being new, viz. *C. Reinhardti* and *C. Morieri*. He divides the genus into two sections, according as the membranes of the zoogametes serve to form the membrane of the zygospore, or the oospore surrounds itself with a membrane of its own, the former section, including *C. Reinhardti* and *multifilis*, the latter *C. pulvisculus* and *Morieri*.

In *C. Reinhardti* the biciliated zoogametes are indistinguishable before conjugation; the zygospore contains corpuscles which have often been mistaken for nuclei. In *C. multifilis* Fres., the zoogametes have four cilia; the zygospore breaks up into a colony resembling that of *Pleurococcus*. In *C. pulvisculus* Müll., the female zoogametes are distinctly larger than the male. *C. Morieri* displays a peculiar kind of conjugation. When the zoogametes come together, a perforation takes place in their cell-walls; their cilia disappear; and the protoplasts of the two cells fuse together through the perforation. This species also develops non-sexual zoospores, which become resting-spores in the winter.

Considerable doubt rests upon other species which have been included in the genus.

*Chlamydococcus pluvialis*.†—M. P. A. Dangeard reviews the previous observations on this organism (*Protococcus pluvialis* A. Br., *Hæmatococcus lacustris* Gir.). He confirms the observations of Rostafinski as to the formation of two kinds of zoospore, microzoospore and macrozoospore, and compares the structure to that of *Gonium pectorale*; the only difference being that while in that genus the macrospores and microspores remain united in one plane, in *Chlamydomonas* and *Chlamydococcus* they separate from one another. The zoospores of *C. pluvialis* become encysted in the winter, and then constitute resting-spores of a red colour, in which condition they may remain dormant for a very long period. Before germinating the external red layer again becomes green, and divides into zoospores which escape by the rupture of the membrane of the resting-spore. The statement of some observers that conjugation takes place between the macrozoospores the author believes to rest on an error of observation; as is also the case with the so-called amœboid phase.

Cell-membrane and Gelatinous Envelope of Desmidiæ.‡—Herr P. Hauptfleisch has made a series of very careful observations on the investing cell-wall and gelatinous sheath of the desmids. The two halves of the cell are not exactly symmetrical, the plane of symmetry of one half lying at an acute angle to that of the other half. Hence the two cells which remain connected after division, or the filament where a number are united together, always exhibits an evident torsion.

The wall of a desmid-cell always consists of two separate pieces,

\* Bull. Soc. Linn. Normandie, i. 1886-7 (1888) pp. 151-8. † Ibid., pp. 43-9.

‡ 'Zellmembran u. Hüllgallerte d. Desmidiaceen,' 78 pp. and 3 pls., Greifswald, 1888. See Hedwigia, xxvii. (1888) p. 199.

which firmly embrace one another by their sharp edges; and these two shells can be more or less easily separated by pressure. An exception is presented in *Spirotænia*, where the whole cell-membrane consists of a single connected piece, and the author proposes to unite this genus with *Mesotænium* and *Cylindrocystis* into a distinct group intermediate between the Desmidiæ and Zygnemacææ. In some species of *Penium* and *Closterium* the cell-wall consists of more than two pieces, and each of the two shells is also provided with a girdle-band formed subsequently. The author considers this structure of the cell-membrane to indicate an evident affinity between the Desmidiæ and the Diatomacææ.

When the cell is about to divide, a short cylindrical piece of cell-wall is first of all intercalated on the inside of each cell on the line of contact, and this becomes set free by the separation of the two shells. It is only in some species of *Closterium* that the wall of the two shells opens by a transverse fissure. A cylindrical cushion is then formed on its inner side, which gradually develops into a complete septum. A fresh half-cell is gradually formed on the inner side of the newly-formed septum.

Independently of the well-known warts, spines, &c., the cell-wall of desmids is, in almost all cases, perforated by regularly arranged pore-canal, through which pass fine threads of protoplasm from the interior of the cell, ending on the outside in smaller or larger knobs. The warts, spines, and ribs of the cell-wall are hollow, and are usually destitute of these pore canals.

The majority of desmids are invested in a narrow or broader gelatinous envelope, which is sometimes easily visible, in other cases only by the use of staining reagents. This envelope is always composed of caps or prisms, placed separately on the pores of the cell-wall, and usually closely connected into a continuous layer. These prisms are in many cases (*Didymoprium*, &c.) penetrated by tufts of finer threads proceeding from the knobs which terminate the threads which perforate the pores, ending in very fine cilia at the surface of the envelope. The gelatinous envelope of the individual cells is at times thrown off, and a fresh envelope then excreted by the cell. In those species in which no evident pores were detected in the cell-wall there was also no enveloping gelatinous sheath. The author believes that the substance of the gelatinous envelope is excreted from the protoplasm of the cell through the pores, and that its chief purpose is to protect the knobs of the threads and especially the tufts of delicate cilia. Whether these serve for the conduction of irritation, or for absorption or excretion, he was unable to determine.

In those species where the cells are united into filaments, the end-surfaces are also perforated, but exhibit no visible jelly; except that in *Sphærozoma* the individual cells are surrounded by jelly, and in *Desmidiium* jelly is also formed in cavities of the septa. The end-surfaces of the cells of these filamentous desmids are either altogether in contact (*Hyalotheca mucosa*) or only at certain points (*Desmidiium*, *Didymoprium*); and although threads of protoplasm could not with certainty be detected passing through the pores, it is most probable that the protoplasm of the filament is in this way connected through its whole length.

In young shells formed as the result of cell-division, the gelatinous envelope is usually not formed until after the shell is fully developed. Up to this time, in the filamentous forms, the growing shells are covered and protected by the envelopes of the old shells. The pores are also

usually not to be seen until the cell-membrane is fully developed. When first formed they are exceedingly minute; they then gradually increase in size, and it is only when they have attained a considerable size that prisms of jelly are excreted through them. In some species the newly-formed shells of the mature individuals which result from division are partially or entirely thrown off and replaced by new shells; and these temporary shells are then destitute of pores.

### Fungi.

“Spermatia” of the Ascomycetes.\*—Herr A. Möller adduces further arguments against the hypothesis that these organs have sexual functions. The “spermatia” of *Collema microphyllum*, after lying for one month in a nutrient solution, begin to show signs of germination; in the course of the second or third month they put out protuberances in two or three directions; and in the fourth month a branched tube has made its appearance. In no single case has the union of a “spermatium” with a trichogyne been demonstrated; in addition to the improbability that so minute a body could transmit its fertilizing power through a row of twenty-four cells. The argument drawn from the swarm-cells of the Ectocarpeæ—that bodies which have sexual functions can still germinate directly when the opportunity of exercising that function is wanting—he dismisses on the ground of the very distant relationship between the Ectocarpeæ and the Ascomycetes.

Basidiomycetes.†—The last published part of Cohn’s ‘Cryptogamic Flora of Silesia,’ compiled by Dr. J. Schröter, treats of Tremellinei, comprising the genera *Sebacina*, *Exidia*, *Ulocolla*, *Craterocolla*, *Tremella*, *Tremellodon*, and the new genus *Tulasnella*, with the following diagnosis:—On globular basidia, similar to those of *Tremella*, but undivided, are formed thick ovate sterigmata resembling large spores or the partial basidia of the Tremellinei, which lengthen, and bear spores at their sharp-pointed ends. It is intermediate between *Sebacina* and *Thelephora*, but its position among the Tremellinei is doubtful.

Then follows an account of the Dacryomyces, comprising the genera *Dacryomyces*, *Guepinia*, *Calocera*, *Dacryomitra*, and doubtfully *Ditiola*, with insufficiently known basidia, and the Hymenomyces, which are arranged under eight families:—Exobasidiacei, Hypochnacei, Thelephoracei, Clavariacei, Hydnacei, Polyporacei, Cantharellacei, and Agaricacei. The following new genera belonging to the Hymenomyces are described:—*Hypnochella*, *Aleurodiscus*, *Clavulina*, *Phæodon*, *Amaurodon*, *Oclroporus*, *Phæoporus*, and *Dædaleopsis*, as well as a number of new species.

Heterobasidial Basidiomycetes.‡—M. J. Costantin criticizes the publication of MM. Brefeld, Istvánffi, and Johan-Olsen § on the Protobasidiomycetes, especially on some points of classification and nomenclature; and gives himself a review of the conidial filamentous forms described in Brefeld’s work, comparing them with the known genera of Mucedineæ.

\* Bot. Ztg., xlv. (1888) pp. 421-5. Cf. this Journal, *ante*, p. 466.

† ‘Kryptogamen-Flora v. Schlesien,’ Bd. iii. Lief. 4, Breslau, 1888. See Hedwigia, xxvii. (1888) p. 213. Cf. this Journal, *ante*, p. 79.

‡ Morot’s Journ. de Bot., ii. (1888) pp. 229-34.

§ Cf. this Journal, *ante*, p. 778.

**Polyporeæ.\***—M. J. de Seynes traces the complete life-history of two species belonging to this family:—*Polyporus sulfureus* and *biennis*.

In *P. sulfureus* the thickenings in the cell-walls are often coloured blue by iodine. The reproductive bodies are of two types, spores and conidia. The spores are usually developed on basidia. The conidia may be formed either on the mycelium, or in the interior of the sporiferous receptacle, or in the receptacles which produce nothing but conidia, which resemble a Myxomycete, and have been described under the name *Ptychogaster aurantiacus*. The mycelial conidia are produced in the interior of the woody tissue of the tree on which the *Polyporus* grows.

*P. biennis* may occur in the condition of *Fibrillaria* or of *Ceriumyces*; the former being a kind of rhizomorph; the latter consisting of rounded tubercles or stalked cones. The basidia are replaced by branching conidiophores which may produce larger or smaller conidia.

**Prototremella.†**—M. N. Patouillard characterizes this new genus of heterobasidioid Hymenomycetes as follows:—*Prototremella* nov. gen. A heterobasidioid Hymenomycete with an exposed, sub-gelatinous receptacle, the simple basidia carrying four large sterigmata; spores and conidia globular.

This fungus is met with on the willow and poplar, and has been named *Prototremella Tulasnei* by the author; two other species are indicated, which possibly belong to this genus: *Corticium uvidum* Fr., and *Exidiopsis effusa* Brefeld.

**Ascospora Beijerinckii.‡**—M. P. Vuillemin describes *Ascospora Beijerinckii*, a parasite which attacks cherry trees. On the black spots which may be seen on the surface of the fruit, various adaptations of the mycelium for its latent life will be found. The violet-brown filaments with thick walls frequently take a moniliform aspect. Stylospores and pycnidia are also formed. The perithecia are black, depressed, spherical in shape, and with either a very small opening or none at all. At first the ripe asci are ovoid, being attached by the larger extremity; they inclose eight spores.

**Uredinæ and their Hosts.§**—Herr P. Dietel has here classified all the known species of Uredinæ, 980 in number, according to their host plants, which belong to 122 different families. The greatest amount of heterocism is displayed by the parasites of the Compositæ and the Gramineæ. Among Rosaceæ, true species of *Phragmidium* occur only on the Roseæ, Potentillæ, Rubeæ, and Poterieæ, while the *Gymnosporangia* are confined to the Pomeæ. The 12 species of the exotic genus *Ravenelia* are confined to the Leguminosæ, the species of *Hemileia* to the Rubiaceæ, and *Pileolaria* to the Anacardiaceæ. On 120 species of Compositæ there are known, as parasites, 25 æidia, 9 *Uromyces*, about 20 *Puccinæ*, 1 *Cronartium*, 1 *Melampora*, and 3 *Coleosporiæ*.

**Structure and Life-history of Puccinia Graminis.||**—Prof. H. Marshall Ward describes in this paper a portion of a series of illustrations of life-histories of parasitic fungi, which he has made for the

\* 'Rech. pour servir à l'hist. nat. des végétaux inférieurs,' pt. ii. Polypores, 66 pp. and 6 pls. See Bull. Soc. Bot. France, xxxv. (1888) Rev. Bibl., p. 114.

† Morot's Journ. de Bot., ii. (1888) pp. 267-70.

‡ Ibid., pp. 255-9.

§ 'Verzeichn. sämtlicher Uredineen, nach Familien ihrer Nährpflanzen geordnet,' 58 pp., 1888. See Bot. Centralbl., xxxv. (1888) p. 187. Cf. this Journal, ante, p. 97.

|| Ann. of Bot., ii. (1888) pp. 217-22 (2 pls.).

Science and Art Department, South Kensington. Fig. 1 is drawn from a longitudinal section through a still green leaf of the wheat, attacked by the fungus in what is termed the *Uredo*-form. In fig. 2 are seen the details of development of the uredospores under a higher power. Fig. 3 shows a series of four successive stages in the germination of the same uredospore, sown in water on glass. Fig. 4 is a longitudinal section through the leaf of a young wheat plant, on which uredospores had been allowed to germinate for 48 hours. In fig. 5 is a group of *teliospores*. Fig. 8 shows three of the sporidia germinating in water on glass. Fig. 10 is a transverse section of a leaf of barberry infested with the *Aecidium* form. Fig. 11 is a portion of a very thin section through a spermatogonium.

*Peronospora viticola*.\*—According to Sig. G. Cuboni, this parasite of the vine occurs in two forms:—(1) “forma palese,” on the flower-stalks either before or after flowering, numerous conidiophores appearing through the stomata, and causing the flower or young fruit to perish; and (2) “forma larvata,” on the fruit when nearly ripe, bringing about its discoloration and decay; in this form no conidia appear, but the pulp is permeated by the characteristic unicellular mycelium with its globular haustoria and chamber-like prolongations. Infection takes place on the flower-stalks by the conidia formed on the leaves; the fungus spreads from them to the berries, and not from the berries backwards on to the ax's. Sexual organs are never found on the fruit. The mycelium appears to retain its vitality for a long time in the dead fruits. The remedy recommended is copper sulphate, which prevents the germination of the conidia on the flower-stalks.

*Peronospora* of the Rose.†—Sig. G. Cuboni describes *Peronospora sparsa*, a parasite of the rose, hitherto very rarely seen in Europe. The mycelium has long branched haustoria; the conidiophores project through the stomata on the under side of the leaf, the leaf-stalk, and the flower-stalk. The hitherto unknown oospores were found in the sepals.

Ascophorous form of *Penicillium candidum*.‡—To the species of *Penicillium* of which the ascophorous form is known, viz. *P. glaucum* and *aureum*, Dr. F. Morini now adds *P. candidum*, growing on an acorn of *Quercus pubescens*. The ascophorous hyphæ were only obtained with great difficulty, and Dr. Morini describes in detail several points in which this phase differs from that in the two species named above.

New *Aspergillus*.§—Dr. F. Eichelbaum describes a peculiar form of *Aspergillus*, possibly a new species, from eczema-scales from the human skin. It possesses the peculiarity of presenting all stages of transition between the ordinary mode of formation of the pencils of spores in *Aspergillus* to the simple abstriction of single conidia from the extremities of hyphæ.

*Ombrophila* and *Guepinia*.||—M. L. Quélet states that the genus *Ombrophila* was founded by Fries in 1849, and included two species,

\* Atti Congr. Naz. d. Bot. Critt. Parma, 1887, 20 pp. and 2 pls. See Hedwigia, xxvii. (1888) p. 117.

† Le staz. sperim. agr. ital., xiv. pp. 295-308 (1 pl.). See Hedwigia, xxvii. (1888) p. 210.

‡ Malpighia, ii. (1888) pp. 224-34.

§ SB. Gesell. Bot. Hamburg, Jan. 9, 1888 (1 fig.). See Bot. Centralbl., xxxv. (1888) p. 113.

|| Morot's Journ. de Bot., ii. (1888) p. 322-4.

*O. rubella* P. and *O. lilacina* Wulf. Karsten, however, in 1871, united with it certain species belonging to the genera *Bulgaria* and *Cudonia* (*Helotium* of some authors), while the *Ombrophila* of Boudier (1885) contained one species, *O. clavus* A. S. The genus *Ombrophila* of Phillips (1887) contained three species taken from three different genera, *Bulgaria sarcoides* Jacq., *Cudonia clavus* A. S., and *Calloria atrovirens* Pers. It appears, however, rational and necessary to the author to preserve for the generic name of this group the sense in which it was first given. The genus *Guepinia* Fries has been divided by M. Brefeld into *Gyrocephalus* Pers. and *Dacrymyces* Rees, which division appears quite justifiable.

**Peridermium Pini.\***—Herr H. Klebahn identifies this parasite of the Weymouth pine with *Coleosporium Senecionis* parasitic on *Senecio*. He distinguishes three forms of *Peridermium*, viz.:—(a) *P. Pini acicolum*, with the spore-membrane warty throughout, on leaves of *Pinus sylvestris*; (b) *P. Pini corticolum*, spore-membrane warty, but with a spot that is only areolated, on the bark of *P. sylvestris*; and (c) *P. Strobi* n. sp. or var., spore-membrane warty, with a larger quite smooth space, on the bark of *P. Strobus*.

**Pilacre.†**—According to M. E. Boudier, *Pilacre* is a good genus; although it was not sufficiently characterized at first by its author, this is not a reason for suppressing it and substituting another. *Pilacre faqinea*, *Petersii*, and several others of Berkeley's species are not true *Pilacres*, but belong to the genus *Echyma*, and it is also necessary to substitute this latter name for that of *Pilacre* in the important works of Brefeld. *Pilacre* remains a true discomycetous fungus.

**Fusoma.‡**—On a species of *Fusoma* which he grew equally well on solid and on fluid substrata, M. E. Wasserzug finds three kinds of spore:—septate fusiform conidia, which vary greatly in size and number according to the medium; unseptate conidia, formed either at the extremity of slender mycelial filaments or springing directly from the septate conidia; and a third kind, spherical cysts with thick walls formed within mycelial filaments, and analogous to the so-called chlamydospores of the Mucorini.

**Diplocladium.§**—M. J. Costantin finds a *Diplocladium* parasitic on a morel, and occurring in two forms—a *Diplocladium*-form, and that of a bulbiform sclerotium. He discusses the question whether this latter form is identical with *Hypomyces aurantius* or *ochraceus*, or with an undescribed species of *Hypomyces*, but without coming to any definite decision.

**"Edelfäule" of Grapes.||**—Dr. H. Müller (Thurgau) has determined this disease to be caused by the attacks of a *Botrytis*, the *B. acinorum* of Pers., but identical with *B. cinerea*. Attacking the unripe berries in wet, but only the ripe berries in dry weather, it kills the epidermal cells, increases evaporation, and hence raises the concentration of the juice. It takes up sugar and acids, which it decomposes in the process

\* Abhandl. Naturw. Ver. Bremen, x. pp. 145-55 (1 pl.). See Hedwigia, xxvii. (1888) p. 118.

† Morot's Journ. de Bot., ii. (1888) pp. 261-4.

‡ Bull. Soc. Bot. France, xxxv. (1888) pp. 199-204.

§ Ibid., pp. 291-6.

|| Landwirth. Jahrb., 1888, pp. 83-160 (1 pl.). See Bot. Zeit., xlvi. (1888) p. 429.

of respiration, and hence diminishes the quantity of these substances in the berry. The percentage of sugar in proportion to other substances is, however, increased.

**Stysanus and Hormodendron.\***—MM. J. Costantin and Rolland describe the various stages in the development of *Stysanus*, a genus of Mucedinæ not uncommon on excrement cultures. Also a new species of the allied genus *Hormodendron*, which they call *H. nigro-album*, found on the excrements of a fowl, springing up only after a long period of rest.

**New Mould.†**—Herr E. Eidam finds a new hyphomycetous fungus, to which he gives the name *Coemansia spiralis*, forming white spots on a damp horse-cloth, characterized by the septate unbranched conidiophores being coiled spirally in their upper portion.

**Entomophthoræ of the United States.‡**—Mr. R. Thaxter has commenced the publication of a monograph of the Entomophthoræ of the United States. There are three genera, *Empusa* (including *Entomophthora* and *Triplosporium*), *Massospora*, and *Basidiobolus*. The publication commences with *Empusa*, of which twenty-six species are recognized, sixteen of them new.

**Gonidia of Gymnosporangium.§**—Herr F. Kienitz-Gerloff has detected two kinds of gonidia on *Gymnosporangium clavariæforme* growing on the juniper, one chiefly in the interior, the other near the periphery of the fructification. Both are double spores, and about 0.09 mm. in length. In the former the pedicel has usually disappeared as mucilage; they are equally pointed at the two ends, and strongly constricted in the middle, and have a thin and colourless membrane, and finely granular yellow-brown contents; the latter are always stalked, more pointed at one end than the other; they have a scarcely perceptible constriction, their membrane is dark brown and much thicker, and their contents are not granular, resembling those of ordinary teleutospores. These latter form, on germination, at most four, usually only one or two germinating tubes, as is usually the case with teleutospores; the former, on the contrary, always form more than one, usually about five. He suggests that the thin-walled spores may possibly be the hitherto unknown uredospores of *Gymnosporangium*.

**Recent Researches on the Saprolegniæ. ||**—Prof. M. Hartog discusses recent researches on the Saprolegniæ, and more particularly those of Rothert published in the 'Proceedings of the Cracow Academy,' xvii., 1887.

Rothert's paper affords the first full and complete account of the double segregation and homogeneous stage, worked out independently, but confirming the author's views as far as they go. His paper, however, does more than this; it affords the first complete account of the formation of the zoosporangium, its septum, and the tubular process through which the spores escape.

The author then gives an abstract of Rothert's paper, and supple-

\* Bull. Soc. Bot. France, xxxv. (1888) pp. 296-302.

† JB. Schles. Gesell. Väterl. Cultur, 1887, pp. 262-5. See Bot. Centralbl., xxxv. (1888) p. 304.

‡ Proc. Boston Soc. Nat. Hist., iv. (1888) pp. 131-201 (8 pls.). See Bot. Gazette, xiii. (1888) p. 194.

§ Bot. Zig., xlvi. (1888) pp. 389-93 (1 pl.).

|| Ann. of Bot., ii. (1888) pp. 201-16.

ments this abstract by the criticism of all points on which his own work has led him to take a different view. Rothert's work was principally conducted on three forms of *Saprolegnia* belonging to the *ferax* group; and he has shown that these species are far more favourable than *Dictyuchus* or *Achlya*.

*Chytridium elegans*, n. sp., a Parasite of the Rotatoria.\*—Prof. E. Perroncito found that *Philodina roseola* Ehrenberg, the characteristics of which are “*Philodina roseola* aut *carnea*, *lævis*, *ocellis ovatis*, *pedis corniculis*” was very common in the hot-springs of Vinadio and Valdieri. These Rotatoria often die from disease produced by vegetable parasites, of which the author has observed two instances. One of these is characterized by the slowing down of the movement of the rotifer, the body of which contracts to form a spherical mass. With a magnification of 350–500 there can be observed in the body of the animal cell elements with thick nucleus and sharply-defined nucleoli. These cells are spherical, oval, or pyriform with well-defined outline and with a diameter of 20–30  $\mu$ .

With these cells the cuticula of the animal becomes completely filled, and they are the cause of gradual death. The skin of the rotifer is finally perforated by processes of the parasite. These processes are tubular masses of protoplasm, and finally give exit to zoospores. When treated with iodine water, the parasite turns yellow, and if sulphuric acid be added, the nuclei of the cells become a deep red-violet. The spores which at maturity form the contents of the parasitic cells are 2  $\mu$ , rarely 3–4  $\mu$  broad, and reflect a pale yellow light. When quite ripe the spores are reddish, oval, and mobile. In one cell there may be 30–50 or more 4–5  $\mu$  long, 2–3  $\mu$  broad, and each of them is provided with two long delicate flagella. When free their movements are very lively.

In form, structure, and development, this parasite shows great resemblance to some Chytridineæ, their zoospores are identical, and they have the same kind of development. The filamentous processes are, however, simple, while in the best known forms of Chytridineæ they are complex. This characteristic the author thinks is insufficient to make a new genus, and he therefore calls his parasite *Chytridium elegans* n. sp.

**New Chytridium.** †—Under the name *Chytridium luxurians* Herr A. Tomaschek describes a new species distinguished by its rapid growth and the great abundance of the zoosporangia. It made its appearance in the method of pollen-grain cultivation of the lower fungi described by Zopf (for the proposal of which method Tomaschek claims priority), modified in the following way. The pollen of conifers is scattered over several layers of filter-paper and laid on an ordinary flower-pot filled with sand, which is placed in a vessel of water and covered by a bell-glass. On the pollen-grains are rapidly developed a number of forms belonging to the lower fungi.

**Parasites of the Higher Fungi.** ‡—M. J. Costantin describes and discusses the correct position of several fungus-parasites found on Agaricini and *Pezizæ*:—1. *Asterothecium strigosum* Wall., found on *Peziza hemisphærica*, appears to be quite distinct from *A. Pezizæ* Cord.

\* Centralbl. f. Bakteriöl. u. Parasitenk., iv. (1888) pp. 295–9.

† Bot. Centralbl., xxxv. (1888) p. 221.

‡ Bull. Soc. Bot. France, xxxv. (1888) pp. 251–6.

2. *Mycohyne verrina* on species of *Peziza*, is the *Hypomyces verrinus* of Tulasne. 3. *Sphaerocema Leotiarum* on *Leotia lubrica*. This is probably the pyrenial form of *Hypomyces Leotiarum* Fayod.

#### Protophyta.

**Cellular Envelope of the Filamentous Nostocaceæ.\***—M. M. Gomont publishes further details of his investigations on this subject. The true cell-membrane he finds to be always present at all times of the life of the plant, though it is always very thin. The enveloping sheath, on the other hand, is gelatinous or membranous, and is composed of parallel lamellæ or of coats inclosed one within another.

As regards the development of these structures in the different families of Filamentous Nostocaceæ:—in the Oscillariaceæ the cellular membrane frequently takes the form of a cap, varying in form in the different species, but constant in each. That this cap does not belong to the mucilaginous sheath, as was supposed by Borzi,† is shown by the fact that it is frequently formed within the prolonged tube of the latter when the filament is broken. This cap was observed in many species belonging to different genera, fresh-water, saline, and terrestrial; it is especially well developed in *Oscillaria antliaria*.

In the Nostocæ the presence of the cellular membrane can only be demonstrated by the use of reagents. This is also the case in the Seytonemæ and Stigonemæ. In all cases the heterocysts appear also to be provided with this membrane.

In the Rivulariaceæ the terminal hyaline bristle is in perfect continuity with the rest of the cellular membrane; it is distinguished only by having fewer transverse septa, and by the entire absence of granular protoplasm.

The spores of the Nostocaceæ always possess two coats, an exospore and an endospore, the former of which is again composed of two distinct layers, the outer one being very frequently warty or otherwise marked. These spores are always the result of the encysting of ordinary vegetative cells.

**Chlorothecium ‡**—Sig. A. Borzi describes several points not hitherto known in the life-history of *Chlorothecium Pirotteæ*, belonging to the Sciadaceæ. The nearest approach to its structure is presented by *Mischococcus*. It was found especially growing on *Marsilea* and *Chaetomorpha*, in palmelliform colonies of cells with a length of 14–40, and a breadth of 10–18  $\mu$ , with an ultimately thick and firm cell-wall. These cells develop into zoosporangia without any alteration of their primitive form; from each cell there usually escape two or four, rarely only a single zoospore, from 3–5  $\mu$  in length, and provided with a single cilium and a conspicuous eye-spot. Conjugation takes place between these zoospores or zoogametes by gradual fusion. The mature zygospore has a diameter of 7–10  $\mu$ , and a moderately thick but transparent membrane. After hibernating the contents of the zygospore breaks up into two masses, each of which escapes in the form of a zoospore, so that the zygospore is itself a zoosporangium. From these zoospores are again

\* Bull. Soc. Bot. France, xxxv. (1888) pp. 204–36 (2 pls.). Cf. this Journal, ante, p. 632.

† See this Journal, 1887, p. 448.

‡ Malpighia, ii. (1888) pp. 250–9. Cf. this Journal, ante, p. 632.

formed the palmelloid colonies, in which condition *Chlorothecium* may multiply itself non-sexually without producing zoogametes.

**Reproduction of Nephrocytium.\***—M. P. A. Dangeard has observed the hitherto unknown mode of propagation of *Nephrocytium Agardhianum*, by the formation of four or eight colonies within the membrane of the mother-colony, which they finally rupture. They are entirely unprovided with cilia.

**Trochiscia and Tetraedron.†**—Prof. A. Hansgirg proposes to restore Kützing's generic name *Trochiscia* for the *Acanthocladus* of Lagerheim (*Glochiococcus* De Toni), dividing it into the three sections *Acanthococcus*, *Dictyococcus*, and *Kymatococcus*; as also Kützing's *Tetraëdron* (*Astericium* Corda, *Polyedrium* Näg., *Cerasterias* Reinsch), this again consisting of two sections *Polyedrium* and *Pseudostaurastrum*, the latter including Ralfs's *Staurastrum enorme*.

**Polyedriaceæ.‡**—Herr P. F. Reinsch proposes to establish under this name a new family of Palmellaceæ, distinguished by consisting of single cells, with periphery either regularly geometrical or varying between all degrees of lobing; the number of nuclei is often considerable, and the cell-wall thick. The family is divided into two subdivisions: *Polyedriææ* with simple, *Cerasteriææ* with compound colonies. Each is composed of two genera, the former of *Polyedrium* Näg. (ex part.) and *Closteridium* n. gen., the latter of *Cerasterias* Reinsch and *Thamniastrum* n. gen.; and the total number of species is 27.

*Closteridium* is distinguished by its solitary free-swimming sub-cylindrical or semilunar cells, each pole armed with a single spine. The membrane is thin, but thicker towards the poles, and prolonged into the spine. The cytoplasm is coarsely granular, and contains large chlorophyllous granules. The species have the appearance of a *Closterium*.

In *Thamniastrum* the cells are solitary, free-swimming, and usually composed of six branches arranged in the form of an octohedron. The branches spring from a common centre, and themselves branch repeatedly dichotomously or trichotomously, these secondary branches are ultimately bifurcate; the total number of secondary branches may amount to from 100 to 180.

**Bacillus living at a temperature exceeding 70° C.§**—This microbe (*B. thermophilus*) which has been cultivated by Dr. P. Miquel, is characterized by being viable at a temperature above 70° C. The author's method of obtaining it was as follows:—

In an oil-bath kept at a temperature of 69° are placed several vessels containing sterilized slightly alkaline pepton-bouillon. When the temperature of the bouillon reaches 69°, a drop of sewer (or other dirty water) is allowed to fall into each of the tubes. In twenty-four hours all the vessels have become cloudy from the presence of *B. thermophilus*. The bath is then raised to a temperature of 71° and fresh bouillon tubes placed in it. These new tubes are inoculated with a small drop of the cultivation, and so on to the fourth generation. Then in order to be

\* Bull. Soc. Linn. Normandie, i., 1886-7 (1888) pp. 196-8.

† Hedwigia, xxvii. (1888) pp. 126-32.

‡ Notarisia, iii. (1888) pp. 493-516 (5 pls.).

§ Ann. de Micrographie, i. (1888) pp. 1-10.

certain that the cultivations contain nothing but *B. thermophilus*, fresh tubes are inoculated from the last and are kept at 40°. These tubes remain unaltered.

The author then isolates his bacillus either by the fractional method or on plates: on the latter it thrives well at a temperature of 60°.

The microbe is aerobic, and is formed of motionless filaments variable in length and about 1  $\mu$  thick. It varies in appearance according to the temperature at which it is cultivated. At 50° it appears usually as short rods, at one extremity of which is a simple oval highly refracting spore. At 60° the filaments are longer and the spores less frequent. At 70° the protoplasm of the filaments assumes a granular look, which in cultivations several days old is almost oily. At 71–72° the bacillus has an almost moniliform appearance, and spores are altogether absent. It cannot be cultivated at a temperature below 42°, but between 45° and 70° it thrives very well in a 2 per cent. agar-agar, but the most favourable heat, according to the author, is from 65–70°. Above 70° it grows with considerable difficulty. It is chiefly found in waters containing sewage, it occurs also on the soil, but rarely in the air. It has been found in the alimentary canal of men and animals, a fact which seems to show that it is capable of reproduction at from 37–40°. It is not pathogenic.

**Bacterial Growth at 0° C.\***—The discovery that certain microorganisms exist at 0° C. by Dr. Fischer led him to investigate the subject further, and from the earth and sea-water in the neighbourhood of Kiel harbour fourteen different organisms were found, all growing at 0° C. Of these, besides the *Bacterium phosphorescens* and the "endemic" light bacillus, three were non-illuminant bacilli, and only one of these fluidified gelatin. Of the remaining nine, one was a fungus of undetermined species. Of the eight bacterial forms found in the earth, seven were decidedly rod-like, and four of these caused the gelatin to fluoresce (one with and three without fluidifying). All the foregoing were found to grow at ordinary temperatures also. Their pathogenic properties were not ascertained.

**Cellar Bacteria.†**—Prof. A. Hansgirk, as the result of an examination of subterranean bacteria found in cellars, &c., in Prague, arrives at the conclusion that the subterranean forms differ little, if at all, from bacteria which develop in the light. He further surmises that the cellar bacteria collected by him have been deposited by chance by drain water, &c., which has percolated through. In consequence, however, of the changed conditions of the environment, it is advisable to regard certain forms as new species and varieties, of which the following are examples:—*Leptothrix cellaris* n. sp.; *Bacillus subtilis* n. var. *cellaris*; *Leuconostoc Lagerheimii* n. var. *subterraneum*; *Mycethece cellaris* n. gen. et sp.; *Hyalococcus cellaris* n. sp.; *Bacterium termo* n. var. *subterraneum*; *Micrococcus subterraneus* n. sp.

**Endosporous Bacteria.‡**—Dr. A. Koch describes three new species of endosporous bacteria, and also discusses *Bacillus tumescens* Zopf, *B. alvei* Cheshire and Cheyne, and *B. Brassicæ* Pommer.

\* Centralbl. f. Bakteriol. u. Parasitenk., iv. (1888) pp. 89–92.

† Oesterreich. Bot. Zeitschr., xxxviii. (1888) pp. 227–30, 263–7.

‡ Bot. Ztg., xlv. (1888) pp. 277–87, 293–99, 309–18, 325–32, 341–350 (1 pl. and 31 figs.).

The first of the new species, *B. carotarum*, was found on the root of a carrot which had been boiled and left under a bell-jar for two or three days. It forms long threads, which become more or less twisted, especially if grown on beet-root, when they bear great resemblance to *Spirillum*. It bears endogenous spores, and when in this condition is very similar in appearance to *B. tumescens*; indeed, both these bacilli were found in an approximately pure state on the boiled carrot.

The spores of *B. carotarum* are invested in a membrane which on germination is burst about its equator by the young rod. These, in drop-cultivations, grow rapidly to long filaments, which are always quite motionless. The filaments, which are, while young, straight, afterwards become curved or angularly crooked. They are composed of a number of segments separated by transverse septa only visible by the aid of reagents. The next step after the full development of these filaments is the production of spores, and these are oval bodies  $1.31-2.38 \mu$  long and  $1.03 \mu$  broad, placed at regular intervals along the filament.

In addition to drop-cultivations colonies were grown on gelatin, meat infusion, potato, &c. With regard to the rate of growth, the author found that *B. carotarum* doubled its length at  $30^{\circ}-33^{\circ}$  C. in forty-three minutes, at  $40^{\circ}$  C. in eighteen minutes, and  $45^{\circ}$  in twenty-two minutes.

Heating the spores in the dry state was unable to weaken, much less to destroy, their germinating power, although they were exposed for eight hours to  $100^{\circ}$ , and in some cases four hours to  $120^{\circ}$  C., and it was also determined that air was necessary to start their development.

*B. tumescens* Zopf.—Besides *B. carotarum* another endosporous *Bacterium* forms white colonies upon the boiled root of carrot. The oval bright-looking spores soon swell up in a nutrient medium, and, bursting through the spore membrane equatorially, develop into rods which eventually become irregularly bent. When young the individuals show a certain amount of movement. One of the peculiarities of *B. tumescens* is that in the adult condition the individual elements measure more in breadth than they do in height, that is, measured on the long axis of the filament (breadth =  $2.1 \mu$ , height =  $0.8-1.5 \mu$ ); and another is that frequently amidst a chain of cells one will be seen without a spore. *B. tumescens* grows luxuriantly on solid media, potato, carrot, gelatin plates, &c. It rapidly liquefies the gelatin.

*B. inflatus* nov. sp., found by chance as an impurity in a drop-cultivation, is distinguished by swelling up, so as to assume a lozenge shape, when about to sporulate. The spores are fusiform or bean-shaped, have no definite disposition as regards the cell-axis, and may be two in number. When germinating they escape through an aperture about the middle of the cell. It is only grown with certainty in drop-cultivations in a 1-2 per cent. meat infusion. In large quantities of nutrient medium it grows well, and also on potato. Cultivated on gelatin the colonies are spheroidal; the gelatin is slowly liquefied.

*B. ventriculus* nov. sp., like *B. inflatus*, was discovered as an impurity, and resembles that bacillus in every respect except the arrangement of the individuals in drop-cultivations and in its manner of growth on potato. These differences are considered sufficient by the author to form a basis of distinction between the two species.

The *Bacillus alvei* Cheyne and Cheshire, which forms spores in an

analogous manner to the foregoing, is referred to chiefly to show that the author's own measurements differ from those of Cheyne and Cheshire; the former gives  $1.77\mu$  length of spore and  $0.90\mu$  breadth, while the latter for the same give  $2.12\mu$  and  $1.07\mu$ . The breadth of cell in Canada balsam as given by Cheyne and Cheshire =  $0.83\mu$  and by Koch as  $0.73\mu$ . Notwithstanding these discrepancies, the author considers that the bacillus he investigated was undoubtedly the same as that described by Cheshire and Cheyne as *Bacillus alvei*, the cause of foulbrood in hive bees.

*B. Brassicæ* Pommer resembles *B. carotarum* in appearance, but it is distinguished therefrom by the greater thickness of the spore-membrane, by the closer growth of the filaments, and by the appearance of granules and ill-defined dark spots about the period of spore-formation.

**Supposed Spores of the Typhoid Bacillus.\***—When Gaffky found certain spheroidal bodies, highly refracting, situated at the extremities of the typhoid bacillus, and characterized also by their resistance to anilin dyes, he came to the conclusion that these polar bodies were spores. This conclusion is erroneous, says Dr. H. Buchner, for these polar bodies are wanting in three characteristics of the true endogenous spores, namely, the resistance to dyes, resistance to drying, and their power of germination. In one respect, however, they do resemble spores; that is, in being composed of thickened plasma.

The conditions under which the polar bodies appear in the typhoid bacillus are limited apparently to the acidity of the nutrient medium and the withdrawal of oxygen during cultivation. These the author regards as producing a condition of degeneration, of which the polar bodies are the result. Gaffky had said that these polar bodies were insusceptible to anilin dyes. Quite the contrary, says the author, for these bodies not only take up the dye most strongly, but also retain it longer than the rest of the cell after the action of decolorants. This, he says, is easily shown if a watery solution of gentian-violet be gradually added to a fresh preparation. But if stained on a cover-glass in the usual manner they are not to be seen. Hence, says the author, these polar bodies are due to a retraction of the plasma.

This retraction is produced either as the result of the drying of the cover-glass or by the dye (gentian-violet) acting as a poison. For with other non-poisonous or less poisonous dyes (as phloxin-red), no retraction or staining is observable.

On the whole, the author thinks these polar bodies consist of cell-plasma in a somewhat thicker condition than the rest of the cell-contents because of their affinity for dyes, and also on account of their refraction in the fresh condition.

**Spore-formation in the Bacilli of Xerosis conjunctivæ, Streptococci, and Cholera spirilla.†**—Dr. Neisser thinks that the xerosis bacilli are probably not the specific contagion of xerosis conjunctivæ, as was maintained by Ernst, because he has come across other micro-organisms which are morphologically identical with this bacillus.

The organism in question is a small thin mobile rod divided into two parts by a clear space, and it propagates by division through the clear

\* Centrabl. f. Bakteriologie u. Parasitenkunde, iv. (1888) pp. 353-8, 385-90 (1 pl.).

† Zeitschr. f. Hygiene, iv. (1888) pp. 268-97.

space, and also by spore-formation. As the young bacilli grow up, they may show at both ends prominent spherules, or they may develop into long thick threads, at the extremities of which may appear dark granules. These granules develop into new bacilli, and form a filament placed vertically to the original cell. From the appearances produced by these formations, Neisser supposed them to be gonidia, and in his first work so called them.

The foregoing organisms thrive in various media, especially in agar to which glycerin is added at incubation heat. They do not liquefy gelatin. The reaction of the nutrient is of slight importance, provided it be not too acid. The most suitable method of staining was as follows:—(1) Stain in warm carbolic fuchsin, wash in 1 per cent. sulphuric acid, and then contrast stain with a watery or Loeffler's methylen-blue solution; or (2) stain in anilin-methyl-violet solution, wash in 1 per cent.  $H_2SO_4$ , and contrast stain with an acid brown. By this method the ground-substance and certain granules and spherules of a round or oval shape are distinguishable.

From the microscopical appearances as shown by staining, and from the fact that cultivation experiments always showed spores, it was deduced that the spherules were to be regarded as endogenous spores, and not as resting-spores merely.

In Streptococci nothing analogous to spore-formation was observed. Although a difference in the intensity of staining, and a fission in the direction parallel to that of the chain, were noticed with cholera spirilla, the author's results were negative, and he regards the gaps and spherules found in old agar cultivations as having nothing to do with spores.

**Pathogenic chromo-aromatic Microbe.\***—Prof. V. Galtier has found a new bacillus in a pig which died with well-marked lesions in the respiratory and digestive organs.

This bacillus, which is pathogenic to rabbits and guinea-pigs, is cultivable in various media which have been inoculated with the blood of animals dead after intravenous injection. The chief characteristic of this microbe is its property of secreting a coloured and aromatic substance. In bouillon these microbes form whitish masses, while at the same time the liquid begins to assume a light yellow-green colour, which goes on deepening until it dies away into a slaty-brown. The same hue is observed on agar-agar, on gelatin (which is rapidly liquefied), and on potato. The cultures, especially those made in bouillon, give off a well-marked agreeable and persistent aroma.

**Vibrios.†**—Dr. E. Weibel has continued to investigate the characteristics of these micro-organisms,‡ and the following are the main facts of his communication.

Further examination of the vibrio from nasal mucus, left it an open question whether this microbe could become pathogenic; in some experiments the mice died, in others they did not.

Vibrios from tongue-fur.—Bent rodlets which are about the same size as those of cholera. Some elements are swollen at the ends, and the

\* Journ. de Méd. Vétérinaire et de Zootechnie, xxxix. (1888) June.

† Centralbl. f. Bakteriol. u. Parasitenk., iv. (1888) pp. 225-32 (6 figs.), 257-64 (4 figs.), 289-95.

‡ See this Journal, ante, p. 99.

swellings pick up colour readily, consequently they are not spores. Unlike most vibrios, this one is well stained by Gram's method. It does not liquefy gelatin, but on plates forms characteristic colonies of a dirty white colour, which, in a few days, attain a diameter of 0.3-0.5 mm. It is apparently not pathogenic.

Vibrios from canal mud.—The primary fact connected with these organisms appears to be that certain of them are antagonistic to others; that is, an examination of the canal mud showed various microbes, some of which, when the original material was sown on gelatin plates, were found to disappear. One kind which is very constant is "hay vibrio," and as it would seem to have some connection with rotting substances, the author proposes to alter its cognomen to *Vibrio saprophiles a*. Hay vibrio  $\beta$  might then be renamed *Vibrio saprophiles  $\beta$* . A third form of this class of vibrio, *V. saprophiles  $\gamma$* , morphologically resembles *V. saprophiles a*, but it is of larger dimensions, and has rounded ends. One peculiarity is its tendency to produce abnormal forms, especially in old cultures, and another is the possession of round or oval spaces which are unstainable.

On gelatin-plates the deeper colonies, macroscopically white, attain the diameter of 1/2 mm. in a week. Under a low power the centre of the colony is orange, and the sharply defined margin yellow. The more superficial colonies are less regular. On potato they show a striking inconstancy, although the cultivations are quite pure.

Vibrios which grow with a yellow colour.—On gelatin plates it is noticeable that from canal mud vibrio-colonies frequently appear with a yellow colour. These are morphologically identical, and one description serves for all. They exhibit an extraordinary variety in their growth and form in the same and in different cultivations. Their only constant is their thickness, which is about half that of the cholera vibrio. Degeneration-forms are also found in artificial media. These are characterized by the irregularity of their shape, that is, irregular as to the recognized form of a vibrio. Although morphologically alike, the author finds it necessary to make three varieties of these yellow vibrios, namely *Vibrio aureus, flavus*, and *flavescens*, between which the differences seem comparatively trivial.

The author then proceeds to impart some general considerations on the morphology and biology of vibrios. A vibrio is defined to be a bent rod twisted about its long axis. The degree of bending and torsion, and the relation between the two, determine the shape of the screw, and to all bacteria which, either singly or collectively, are developed with this torsion, the author would give the name of Vibrio.

With regard to spore-formation in vibrios, the author is of opinion that true spore-formation has never been hitherto demonstrated. It is, however, probable, that in the saprophilous vibrios, the formation of resting forms does occur.

Many vibrios show in liquid media characteristic movements, and this is associated with the necessity for oxygen, in which the yellow varieties thrive best.

The part which the author assigns to decomposition vibrios—is, not that of exciting the process, but rather of destroying its results, namely those matters which act harmfully on animal organisms.

Many vibrios possess the power of developing in very dilute nutrient media and of successfully competing therein with other bacteria.

**Physiological Experiments on Organisms of Glairine and Baregine.\***—M. L. Olivier has investigated the question of under what form the sulphur-containing organisms of glairine and baregine lose this metalloid. He finds that they consume their intracellular sulphur without oxidizing it. They produce  $H_2S$  and  $CNS(NH_4)$  which is a sulphosubstituted derivate of an isomer of urea. This fact, which is absolutely new, seems to assign to sulphur a function of which no example is as yet known. It is possible that this body is capable of replacing oxygen in the transformation of albuminoids into amides, and in a general way, in the combustion of living matter. In a further communication † the author gives an account of some further experiments, which show, *inter alia*, that during life the formation of  $SO_3$  follows, and does not precede that of  $H_2S$ . After the death of the organisms the intracellular sulphur may be oxidized, and the reaction is quite different from that which obtains during life.

\* Comptes Rendus, cvi. (1888) pp. 1744-6.

† Tom. cit., pp. 1806-9.



## MICROSCOPY.

## a. Instruments, Accessories, &amp;c.\*

## (1) Stands.

**Ahrens' New Erecting Microscope.\***—In this instrument (fig. 161) the erection of the image is obtained by two right-angled prisms

FIG. 161.

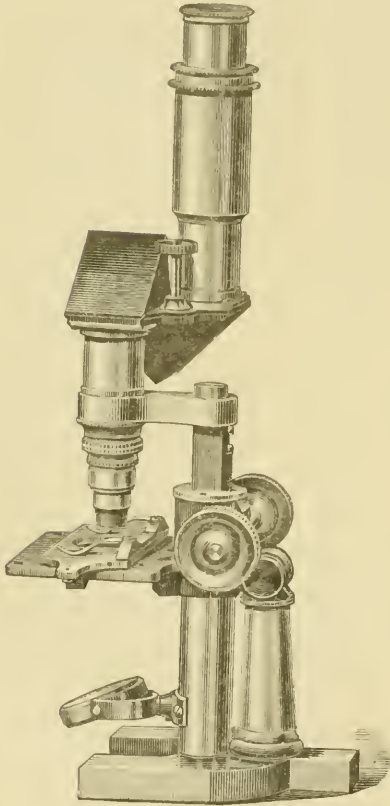

crossed in the way used in some of the binocular field-glasses. The form of the prisms will be gathered from the woodcut, which shows the boxes in which they are placed. The following is Mr. C. D. Ahrens' description of the instrument.

“The advantages of this over the one I made some years ago are that the rays are parallel with the stage, and better definition of the object is given. The prisms are not so troublesome to make, and by making them of quartz more light is obtained. The surfaces are also more perfect, and they are less liable to sweat or get injured. If properly cut they only show one image. As the rays travel across the prisms to the extent of about 3 in., only a short body is required. I believe such an erecting Microscope is the only way to see the objects in their right form, as I have found that lenses when used for inverting make some objects appear as in a pseudoscope with prisms.”

**Klein's Excursion Microscope.†**—Dr. L. Klein writes that botanists and zoologists who are accustomed to make

excursions to collect microscopical specimens only too often feel the want at the collecting place of a useful Microscope which would enable them to determine approximately what they have collected, and to recognize whether a locality offers them any advantage or not. By practice a rough separation of the larger specimens can be made with the naked eye, but of the smaller ones many a rare specimen is over-

\* This subdivision contains (1) Stands; (2) Eye-pieces and Objectives; (3) Illuminating and other Apparatus; (4) Photomicrography; (5) Microscopical Optics and Manipulation; (6) Miscellaneous.

† Zeitschr. f. Wiss. Mikr., v. (1888) pp. 196-9 (3 figs.)

looked which with the Microscope would have been easily recognized as such. Especially annoying is it when, with collecting-glasses full, fresh finds are made, and the question as to what has to be thrown aside has to be answered by macroscopical examination alone.

For excursion purposes the ordinary instruments are too heavy. The cheap school or "Salon" Microscopes are easy of transport, but not sufficiently good for the purpose. The only useful instrument, the so-called *Algensucher* of Zeiss, has the disadvantage that it only gives a very small field of view, so that small interesting objects may be easily overlooked, and much time is consumed in setting up the object.

These considerations induced the author to attempt to combine the advantage of easy portability with the use of a good instrument. The instrument devised by him, and shown in fig. 162, was constructed by Herr R. Winkel of Göttingen, and has been proved by use to be admirably suitable for the purpose intended. The weight of an ordinary Microscope is centered chiefly in the stage, the pillar, and the foot. In the present instrument the stage is made as small as possible (52 mm. by 52 mm.) and the pillar and foot dispensed with altogether and replaced by an ordinary stout walking stick provided with a sharp ferule. The stick is fixed upright in the ground, and thus affords to the Microscope attached to it a most convenient position for observation. The

FIG. 162.

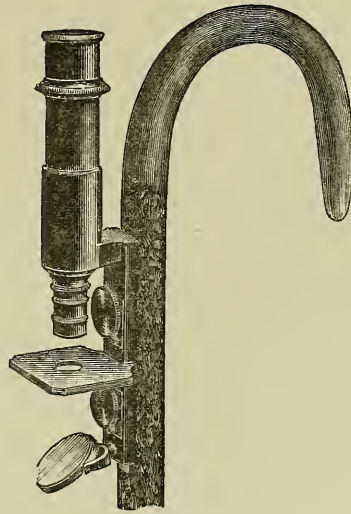
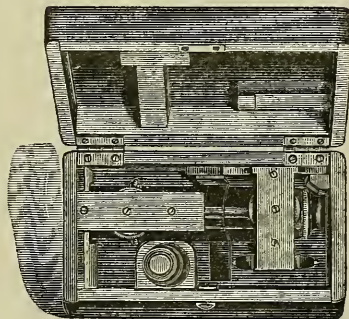

FIG. 163.



FIG. 164.



instrument, for convenience of transport, is made up of three parts :—the stick, near the handle of which is firmly screwed a metal plate (fig. 163)

for the reception of the two principal parts, the socket with the Microscope-tube and the stage with the mirror. These parts, with the objective and eye-piece, are contained in a box 12 cm. long and 6 cm. wide and deep (fig. 164), which can be carried in the pocket or slung across the shoulder by a strap.

The body-tube (115 mm. long) slides by hand in the socket for focusing, but the author suggests replacing this by the ordinary rack-and-pinion arrangement. The socket (46 mm. long) is attached by means of a short arm to a brass piece 19 mm. broad and 60 mm. long, which reaches down to the top of the stage. Through this piece passes a broad-headed screw, by which the socket is firmly screwed to the metal plate on the stick. A pin above and below the screw fitting into corresponding holes in the metal plate helps to keep the socket firmly in position. The stage with the mirror is fastened to the metal plate in a similar way. The mirror is only arranged for direct illumination, but is movable in all directions, so that the handle of the stick can never interfere with the observation. In the figure the stage-opening is represented by mistake as rather too large, so that a diaphragm would be necessary if it were desired to use somewhat high powers. A stage-opening of only 2 to 3 mm. is found to be most suitable for all purposes, and renders diaphragms unnecessary unless a specially low power is used.

**Pritchard's Microscope with "Continental" Fine-adjustment.**—An early form of achromatic Microscope is shown in fig. 165, which, from several points of its construction, we have ventured to assign to the late Andrew Pritchard, and which is interesting from the peculiarity of the fine-adjustment.

The spiral spring encircling the stem, in combination with the arrangement of the fine-adjustment screw below, would seem to indicate that what is generally known as one of the earliest forms of the "Continental" fine-adjustment was very soon adopted in England, if, indeed, its construction here did not precede G. Oberhäuser's, to whom the origination has been generally attributed. It is obvious that, if the spiral spring were sheathed by a tube, the fine-adjustment would be the "Continental" pure and simple.

The rectangular motions of the stage, actuated in diagonal directions on either side of the stem, are similar in design to those shown in one of A. Ross's earliest Microscopes figured in the 7th edition of the 'Encyclopædia Britannica,' and shown in fig. 166 from an extant example, a form which was also issued under Pritchard's name.

The condenser beneath the stage, with its long tube mounting, in the continuation of which the mirror is placed, reminds one of the tube with sliding condenser and mirror below, which formed an accessory to many of the earlier Pritchard and Ross Microscopes, and which was in fact a modification of Wollaston's doublet Microscope.

**Griffith's Fine-adjustment.**—Mr. E. H. Griffith sends us the following description of his new fine-adjustment. In fig. 167, 1, 2, 3 represent the milled head, pinion-axis, and pinion of the ordinary method of coarse-adjustment. The milled-head (1) is countersunk on its inner side, and the small wheel (4) is made to exactly fit the countersunk space, the inner surface of (1) and of the wheel (4) being perfectly smooth and flat. Attached to (4) is the socket and pinion (7), all of which are perfectly fitted over the pinion-axis (2) between the pinion (7) and milled

FIG. 165.

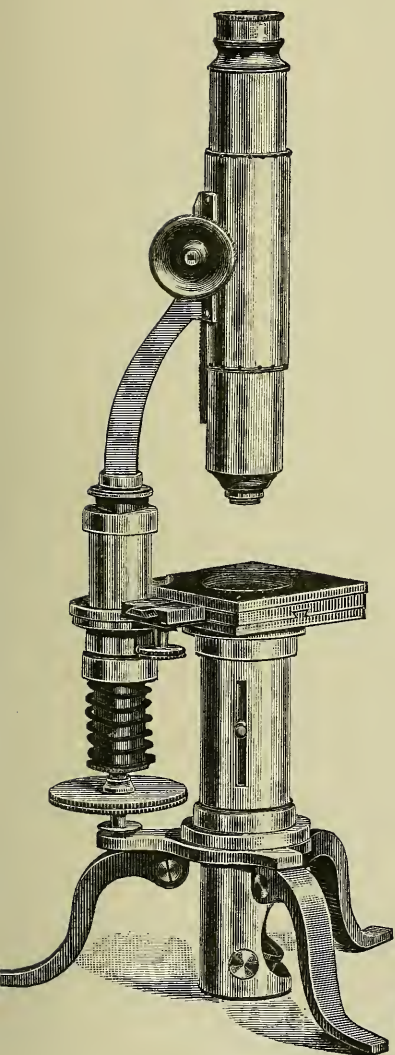
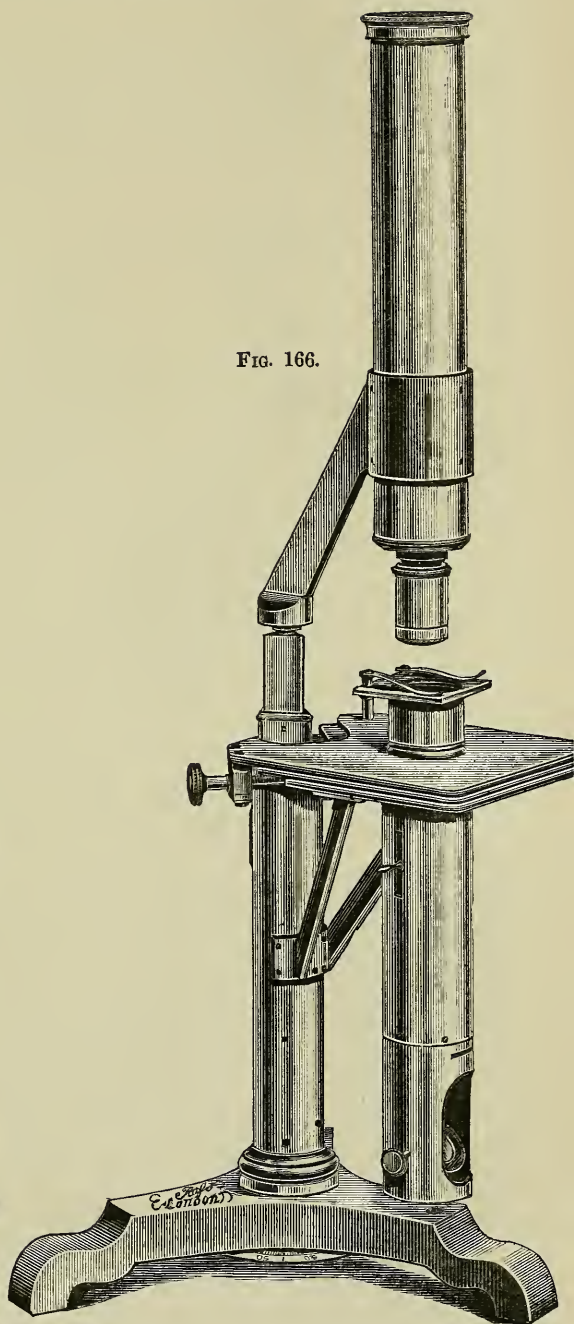

FIG. 166.



head (1). A leather washer (5) is made to rest closely against the inner surfaces of (1) and (4). It is held in position by another washer of metal (6) which, by means of two screws passing through it and (5), is made fast to the milled head. A small tension-wheel (10) has a screw passing through both washers, also binding them to (1), and when desired, locking the coarse-adjustment by making the whole combination prac-

Fig. 167.

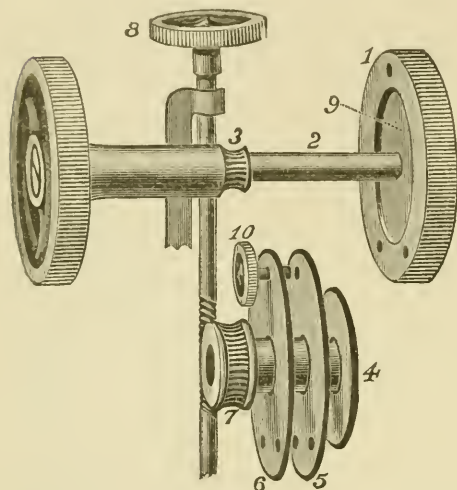
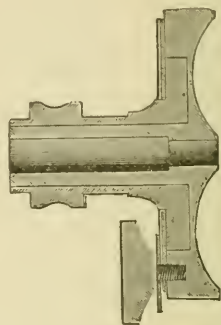

FIG. 168.



tically one wheel. When the coarse-adjustment is used the spindle (8) holds (7), (6), (5), (4), so that they cannot revolve with the pinion.

When the fine-adjustment is required the friction of the leather washer makes the whole combination practically one wheel, which is turned by means of the milled head (8), giving the entire range of the coarse-adjustment. Both adjustments are always ready for use except when the coarse one is purposely locked to prevent accidents. All wear is taken up by the spring as shown in the fig.

Fig. 168 shows the entire combination in proper position.

**Necessity for a Sub-stage.\***—Mr. J. Mayall, junr., in the second series of his Cantor Lectures on the Microscope at the Society of Arts, says that, in his opinion, every Microscope with which it is intended to do serious work should have a racking and centering sub-stage; and if the opticians would supply an adapter fitted with a pivoting diaphragm-carrier, or even a disc of apertures, so that objectives could be conveniently used as condensers, they would add much to the interest of popular microscopy.

As it is, it is to be feared that the great majority of possessors of Microscopes are not aware of the immense advantages attendant upon the use of condensers—achromatic condensers being, of course, far preferable, for it is with them alone that it is really practicable to observe

\* Journ. Soc. Arts, xxxvi. (1888) p. 1169.

objects projected, as it were, in the image of the source of light focused by the condenser. It is, without doubt, highly desirable to have a series of achromatic condensers of different foci, to suit the field of view of objectives of different power. It appears not to be generally known that distancing the lamp from the Microscope will give a considerable range of size of luminous field, with one and the same condenser.

STRICKER, S.—[Electric Microscope.]

[“By the use of his electric Microscope and of silver bromide plates, Prof. Stricker is enabled to get very fine photographs of living bacteria and other moving cells. He has taken photographs of living white blood-corpuscles with high-power lenses, which showed clearly and distinctly the network-like structure of those bodies.”]

*Engl. Mech.*, XLVI. (1888) p. 475.

### (2) Eye-pieces and Objectives.

**Defective Objectives and the Binocular Microscope.**—It has been observed that badly corrected objectives appear worse with the Binocular Microscope than with the single tube. The reason of this is that with a badly corrected lens the different parts of the aperture will not work together exactly, the images formed by different parts disagreeing. In using the binocular different parts of the aperture are always made effective in forming the two images, so that the binocular is to this extent a test for good correction.

HEURCK, H. VAN.—Les nouveaux objectifs apochromatiques de M. Reichert. (The new apochromatic objectives of Herr Reichert.)

*Bull. Soc. Belg. Micr.*, XIV. (1888) pp. 156-9.

SCHULZE, A.—The new Apochromatic Micro-objectives and Compensating Oculars of Dr. Carl Zeiss.

*Proc. and Trans. Nat. Hist. Soc. Glasgow*, II. (1888) pp. 154-62.

SCHULTZE, F. E.—Eine von Herrn Westien in Rostock angefertigte Doppelloupe. (A double lens made by Herr Westien of Rostock.)

*SB. Gesell. Nat. Freunde Berlin*, 1887, pp. 146-7.

” ” Ueber eine binoculäre Präparirloupe. (On a binocular dissecting lens.)

*Tagebl. 60. Versamml. Deutsch. Naturf.*, 1887, p. 112

### (3) Illuminating and other Apparatus.

**Koch's and Max Wolz's Reflector.**—Mr. T. Christy has recently exhibited a novel form of lamp. The lamp is shaded by a metal cover, near the bottom of which is inserted a solid curved rod of glass with a plane end. The light from the lamp passes into the rod, and after various internal total reflections, arrives at the end of the rod, where it may be directed upon the object.

The apparatus has been patented in Germany by Dr. W. Koch and Herr Max Wolz of Bonn, of whose specification the following is a translation :—\*

“As is well known, rays proceeding from a source of light in a glass body on emergence are deflected from the normal. The more oblique the rays, the more are they deflected, the consequence of which is that finally they can no longer emerge, but are reflected back. This happens if the angle of incidence (for glass) amounts to  $40\frac{3}{4}^{\circ}$  and over. Use is

\* Patentschrift No. 42,818, Klasse 4, 29th July, 1887.

made of this physical law in order to totally reflect all light-rays and cause them to pour out on any particular spot. The glass bodies used for this purpose are bent into the form of a parabola, and may consist of solid glass or of a glass bell, in which the source of light is at the vertex of the descending branch of the parabola.

"In the drawings different forms of the instrument are represented: thus fig. 169 shows in elevation and plan a glass bell, which can be used as a lamp-glass. The outer as well as the inner surfaces of this bell are bent on both sides into a parabolic form. The rays from the source of light *l*, situated in an opening *o* in the middle of the bell, are on both sides thrown from one parabolic surface to the other until they

FIG. 169.



FIG. 170.



FIG. 172.



FIG. 171.

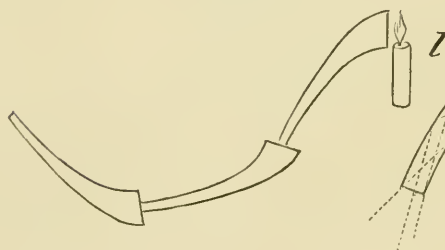

emerge and are dispersed from the lower end. All rays which enter the glass body are totally reflected with the greatest intensity, since each angle of incidence at least amounts to  $40^\circ$ . In the example chosen for the drawing, the side surfaces are not parallel but converge towards a point, in consequence of which the rays are rendered convergent before they emerge from the lower end, and thus the intensity of the emergent beam is heightened.

"This is also the case in the apparatus represented in fig. 170, which may replace the laryngeal, ophthalmoscopic, &c., mirrors hitherto used. By the use of this apparatus the light-rays are directed upon any desired spot and there uniformly distributed, so that no shadows can occur. The glass body in this case consists of a piece of solid glass bent into a parabolic form, to which a small prism can be attached in order better to see through the beam of light.

"By fitting into each other several of such parabolic glasses with sides running both parallel and also towards each other, it is possible to direct the light upon any particular spot which cannot be directly illuminated. Various examples of this are shown in figs. 171 and 172."

Nuttall's Warm Chamber.\*—For experiments on Bacteria at the temperature of the blood Dr. G. Nuttall devised the apparatus shown in

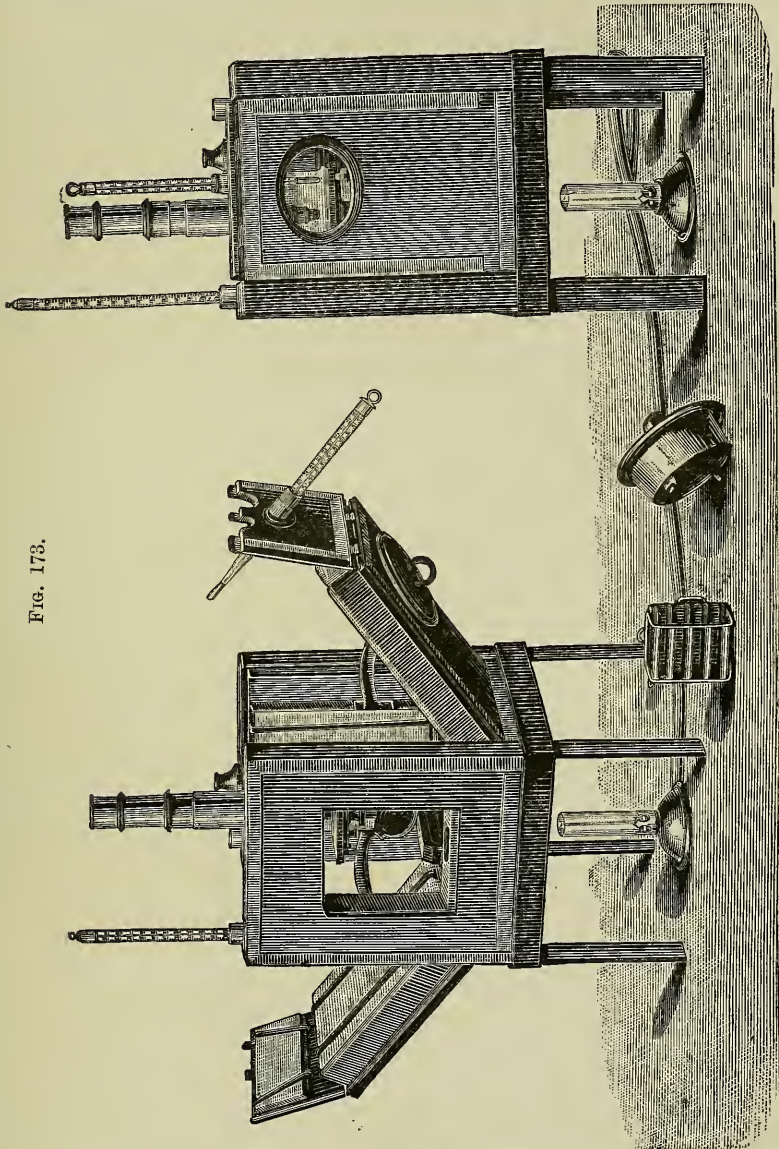

FIG. 173.

fig. 173, which is a modification of the warm chamber of Sachs, the figure on the left being a front view (open), and that on the right a side view (closed).

\* Zeitschr. f. Hygiene, iv. (1888) pp. 353-94 (1 pl. and 1 fig.).

The whole of the lower part of the Microscope, with the object, is inclosed in a metal box, the four walls and bottom of which are double. The two sides are hinged on the bottom so that they can be turned down to facilitate the arrangement of the object in the first instance. These are filled with asbestos; the other two and the bottom being filled with water. The walls and top are covered with felt. A lamp beneath heats the water, which warms the air in the box. A thermometer passing into one of the walls shows the temperature of the water, and a second one passing through the top into the interior shows that of the inclosed air and the object. If it is desired to move the object during observation, an oval opening in one of the sides (closed by the cover shown on the ground between the two figs.) enables the hand to be introduced, and so saves the lowering of temperature which would be likely to arise if the whole side were let down. The inner surfaces of the walls are, in use, lined with several layers of wet blotting-paper.

Dr. Nuttall considers that the apparatus has great advantages over an ordinary warm stage, as the temperature can be maintained to fractions of a degree for a long time, and the thermometer shows accurately the temperature of the object.

**Modification of Pagan's "Growing Slide."\***—Mr. Selmar Schönland, referring to the arrangement designed by the Rev. A. Pagan for growing on microscopical slides small organisms, such as rotifers, algæ, &c., which live in water and require a frequent change of the medium, says that the results obtained with it were very remarkable. In the original design, however, the slide had always to be removed from the Microscope and kept on a specially constructed stage; and although in many cases this is of no importance, yet occasionally it is a very great drawback. The author has, therefore, devised an arrangement which

FIG. 174.

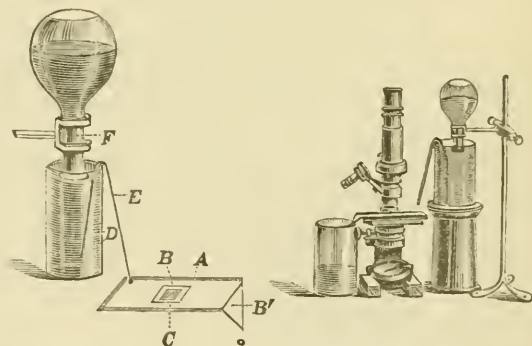

allows of the slide being kept constantly on the stage of the Microscope, and thus of the continuous observation of the same individual for weeks, and even, under certain conditions, for an indefinite period. The arrangement is represented in fig. 174.

The slide A has the ordinary form, but is made slightly longer than

\* Ann. of Bot., ii. (1888) pp. 227-31 (2 figs.).

the stage of the Microscope so as to project a little at both ends. On it is placed a piece of ordinary blotting-paper which just leaves the margins of the slide free; a hole is cut out in the centre of this paper B C, and at one end is a triangular prolongation B', which is bent downwards close to the slide. Water is drawn from a tumbler E by means of a capillary tube D, and drops on to the blotting-paper. The author usually makes the tube just wide enough to allow a small drop of water to escape about every 20 seconds. The water is drained off by the triangular prolongation of the blotting-paper already mentioned. An inverted flask F, filled with water, has its mouth just touching the surface of the water in the tumbler E, and keeps the level of the water in the tumbler constant, thus ensuring the regular escape of drops from the capillary tube D. The capillary tube has a thickened portion in the middle, which is convenient to keep the tube steady. To be quite sure that the tube will work properly, it is well to empty and refill it every 24 or 48 hours. On the right of the fig. the apparatus is represented in use.

DIXON, H. G.—Sub-stage Condensers. *Engl. Mech.*, XLVIII. (1888) p. 199.

GROSSE, W.—Ueber Polarisationsprismen. (On polarizing prisms.)  
72 pp., 2 pls., Kiel, 1888.

KRÜSS, A.—Prismenkombination aus Kalkspath zwecks Mischung und Vergleichung von Lichtbündeln. (Prism-combinations of calc-spar for mixing and comparing light-pencils.)

[German Patent, No. 43,569, 27th September, 1887. Could be used as a comparator such as Inostranoff's.]

*Zeitschr. f. Instrumentenk.*, VIII. (1888) p. 371 (1 fig.).

[MANTON, W. P., and others.]—Sub-stage Condensers.

[Principally a description of the Abbe Condenser.]

*The Microscope*, VIII. (1888) pp. 312-3.

WEISS, D.—Ueber die Hämatoskopie des Dr. A. Hénotque.

*Prag. Med. Wochenschr.*, XIII. (1888) p. 117.

#### (4) Photomicrography.

Jeserich's Photomicrographic Apparatus.\*—Dr. P. Jeserich describes the apparatus shown in fig. 175, which can be used either with sunlight or artificial illumination and either vertical or horizontal, and an ordinary Microscope can be used, provided it has a horse-shoe base with sufficiently wide space to admit the light from the illuminating apparatus.

The instrument consists of a rectangular iron base, to which are screwed four vertical iron uprights of L shaped section, forming guides for the camera to slide in. The camera can be fixed at any height to a plate between two of the uprights by means of a nut and bolt passing through a slot in the plate. These two uprights are accurately graduated, so that an index on the camera gives the distance of the objective from the focusing plate. The index lies at a point a little below the focusing plate; consequently the zero point of the scale is placed at the same distance below the objective, and the true distance between the plate and the objective is then given by a direct reading. At the height of the body-tube is a very shallow box, or kind of camera, fixed in the same way by bolt and nut in the vertical slot, and united by a bellows connection to the first camera. The lower face of the smaller camera has in its centre a small opening provided with a screw-thread to receive a

\* Jeserich, P., 'Die Mikrophotographie,' Svo, Berlin, 1888, pp. 99-105 (2 figs.).

photographic objective. The objective may be replaced by an adapter, which acts as a light-proof connection with the Microscope when the latter is used. The light from the illuminating apparatus is transmitted through a circular opening in the base-plate; and the Microscope is screwed to the base by three adjustment-screws, so that the tube is vertically above this opening and vertically below the centre of the camera. The whole apparatus is placed on a strong wooden table. The illuminating apparatus is attached to the upright shown in the figure,

FIG. 175.

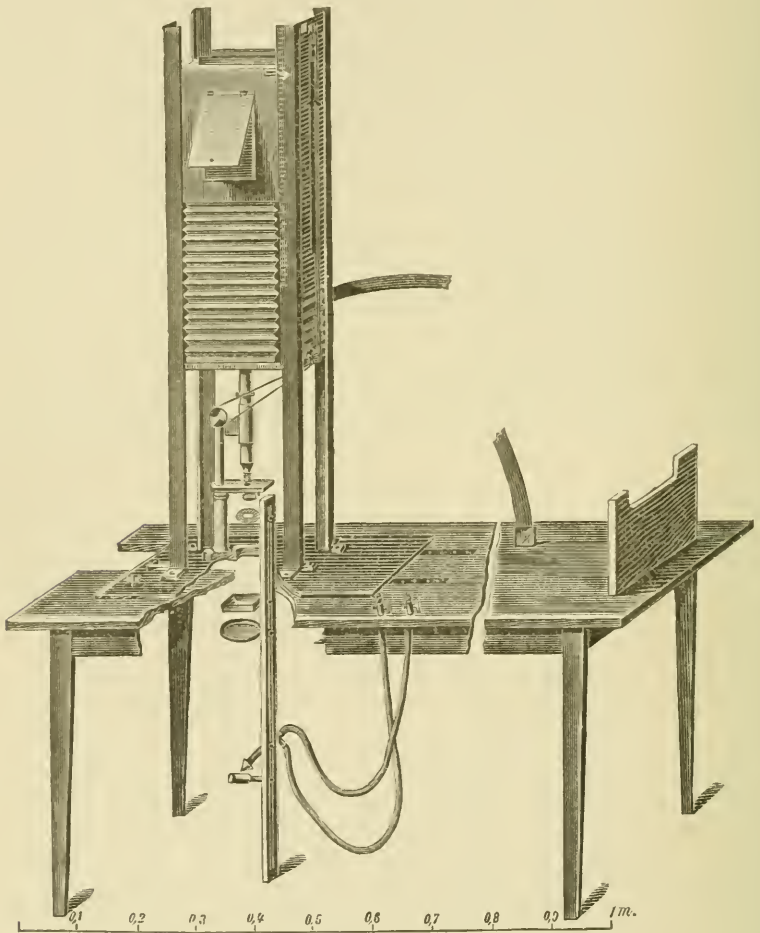

and can be adjusted as required. The mechanism for moving the fine-adjustment is described in the next note but one. The camera can be easily used in a horizontal position. For this purpose the base-plate is hinged to the table on the right-hand side, so that it can be inclined along a

semicircular guide until it finally rests in a horizontal position upon the support at the end of the table. In this position the apparatus is at a height of about 70 cm.

**Griffith's Photomicrographic Camera.**—Mr. E. H. Griffith suggests the use of a camera made of a wire spring cone in the place of the ordinary bellows (fig. 176).

The wire is properly tempered and of sufficient diameter to keep it in position. It is covered with black tape to prevent reflection, and a closely fitting piece of black cloth or other suitable material is placed over the entire frame. For transportation the camera may be put in a very small space, and it is less liable to accident than those with bellows made of leather.

FIG. 176.

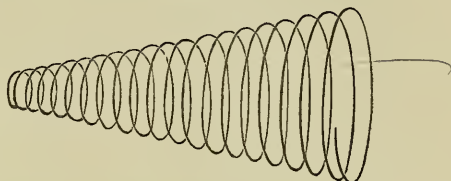

**Jeserich's Focusing Arrangement.\***—Figs. 177 and 178 represent Dr. P. Jeserich's contrivance for working the micrometer screw from a distance where the upper part of the Microscope with the stage is made to revolve, as in the Hartnack model, the mechanism following all the changes of position and the micrometer screw not being loaded.

S is a horizontal endless screw working in bearings at X X attached to the cross-piece of the Microscope; at one end this screw carries a grooved wheel R of about 5-6 cm. diameter, which serves as a pulley, any motion of which is communicated by means of S to the toothed wheel Z, which is attached to the micrometer screw. The endless cord passes from R over two freely-moving pulleys upon one axle attached by a clamp to the face of the camera, and from these over two similar pulleys at the other end of the camera; beyond these a weighted pulley G (5-10 grams) is suspended on the cord so as to keep it always taut. The

FIG. 177.

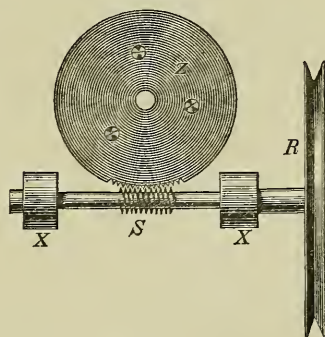
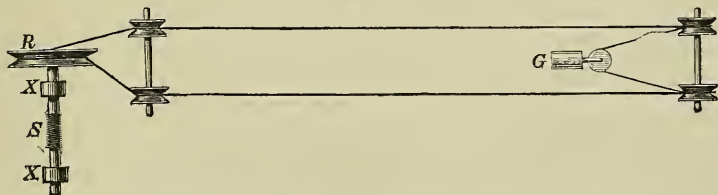

FIG. 178.



least movement of the string is thus communicated to the micrometer screw, while the whole apparatus is able to follow any movement of the

\* Jeserich, P., 'Die Mikrophotographie,' 8vo, Berlin, 1888, pp. 132-4 (3 figs.).

Microscope. The most convenient arrangement for the cord is shown in fig. 178, in which position it can be used with a vertical, inclined, or horizontal camera.

**Stenglein's Coarse and Fine Focusing Arrangements.\***—After describing a form of horizontal camera which does not present any novel features, Herr M. Stenglein describes the method he adopts for moving the coarse-adjustment. C (fig. 179) is the milled head of the Microscope

FIG. 179.

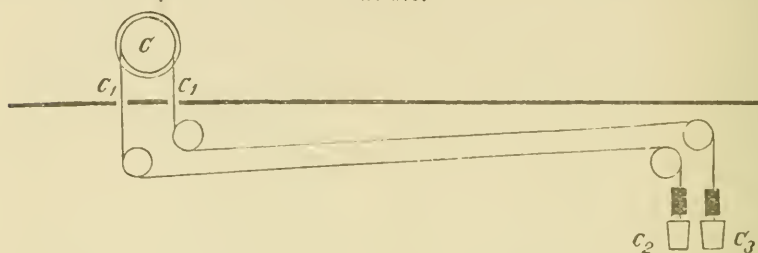

round which is a cord;  $C^1 C^1$  are holes in the base-board for the cord to pass through, and  $C^2 C^3$  weights attached to the cord at the focusing end of the camera. Each half of the cord passes over a couple of fixed pulleys.

The device employed for moving the fine-adjustment is shown in fig. 180, and is claimed to be better than any arrangement with toothed wheels.

FIG. 180.

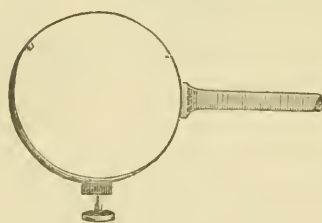

It consists of a brass ring, the circumference of which is a little larger than the head of the micrometer screw; on its inner side are two fixed points, while a third is supplied by a screw which serves to secure the ring to the milled head. To the outside of the ring is fixed a light and thin brass plate 45 mm. long, from the extremity of which the cords pass over two pulleys

fixed to the board on each side of the camera. At the opposite end of the camera the cords again pass over a pair of pulleys, and are kept taut by a weight of 25–30 gr. By pulling one or other of the cords motion is imparted to the micrometer screw.

**Adaptation of the ordinary Eye-piece for Photomicrography.**†—Dr. R. Neuhaus has found that if the lenses in the eye-piece be separated for a little distance and an additional diaphragm fitted on, an image just as sharp as can be obtained with the expensive projection-ocular is thrown on the focusing screen.

The arrangement is extremely simple; a paper case or tube,  $2\frac{1}{2}$  cm. long, is fitted on to the brass tube of the eye-piece. The internal diaphragm remains in its original place, while the new one is fixed over the eye-piece by means of a short movable tube.

\* Centralbl. f. Bakteriolog. u. Parasitenk., iii. (1888) pp. 442–5, 471–5 (3 figs.).

† Zeitschr. f. Wiss. Mikr., v. (1888) pp. 328–9.

The nearer the objects to be photographed are to the focusing disc, the greater distance must the lenses of the eye-piece be removed from one another. On the whole the lengthening varies from 1 to 2 cm.

**Illumination of Objects in Photomicrography.\***—Dr. M. Stenglein gives the results of his experiments on this subject. In photographing a microscopical preparation, the light is passed through a condensing lens on to the object, the image of which is thrown on some white screen. If now the object be removed, the image of the light will appear in its place. And the examination of this picture shows that its surface is not illuminated with perfect regularity, but that all the irregularities of the zirconium and calcium plates are reproduced in the zirconium and calcium lights. If a petroleum lamp with circular wick be used, the dark streak in the centre of the flame appears.

If now the image of the light be made to approach the objective, it will be noticed that the above-mentioned image gradually disappears and in its place there appears upon the white disc a circle which is more or less bright, according as the position of the image is in the objective or in front of it.

Now if the illuminating lens be covered with a screen behind which in a properly darkened room the cone of light can be observed, it will be rendered evident that when the greatest possible brightness of the light-circle is observed on the white screen, the cone of light is interrupted at the aperture of the objective.

If the cone be smaller than the objective's aperture, the image of the light shows more or less sharply on the white screen, and therefore all the shadow-lines of the source of light. If the cone be larger than the aperture, then the light and dark circles appear. If, having in the above described way obtained the greatest brightness and a regular illumination, the object to be photographed is inserted, it will be found that the sharpness of the image towards the margin is much increased.

The author's experiments were made with Klönne and Müller's 1, 2, 3, 4 objectives, and an apochromatic of Zeiss with 0.30 aperture and 30.0 mm. focal distance.

**Zirconium Light for Photomicrography.†**—Herren Schmidt and Haensch have recently brought out a new burner for photomicrographic purposes; in this zirconium replaces the calcium cylinder, which is found in practice to become partially consumed, and hence a rapid deterioration of the light. Zirconium is found to be very resistant, even in the hottest part of the flame, and a small plate thereof fixed in platinum and placed in the hottest part of the flame gives a splendid white light, the spectrum of which extends from A to H, and is perfectly continuous, being unbroken by any lines. The advantages of the light are that it gives a regular flame in any position, and when focused for the optical axis of an apparatus the illuminating point remains steady at the same spot.

ARSONVAL, — D'.—Nouvelle lumière par incandescence du gaz d'éclairage. Application à l'examen microscopique, à l'analyse spectrale et la photographie. (New incandescent gas-light; its application to microscopical examination, spectral analysis and photography.)

*CR. Soc. Biol.*, V. (1888) No. 8.

\* *Centralbl. f. Bakteriol. u. Parasitenk.*, iii. (1888) pp. 511-2.

† *Zeitschr. f. Wiss. Mikr.*, v. (1888) p. 225.

EGBERT, S.—An Appliance for making Photo-micrographs with the Microscope in the upright position.

[Simply a right-angled prism.]

*The Microscope*, VIII. (1888) pp. 310-2 (2 figs.).

Photomicrographic Apparatus, Some.

*Scientific News*, II. (1888) pp. 361-2 (1 fig.), 378-9 (2 figs.), 402-3 (2 figs.).

Schmidt & Haensch, Die neue verbesserte Vergrößerungscamera von. (The new improved enlarging camera of Schmidt and Haensch.)

*Phot. Mittheil. v. Vogel*, I. (1888) February, 4 pp.

ZEISS, C.—Special-Katalog über Apparate für Mikrophotographie. 4to, Jena, 1888.

#### (5) Microscopical Optics and Manipulation.

Microscopical Optics and the Quekett Club Journal.—Our remarks on this subject at p. 817 have produced letters from Mr. H. Morland and Mr. T. F. Smith,\* the two authors whose papers were referred to, and also from "A Member of both Societies.† These letters illustrate in so marked a manner what we desired to enforce, that we deal with them further here.

One of Mr. Morland's original blunders was expressed in the following words:—"The only objection to my mind against this medium is that "its refractive index is not sufficiently high for the new immersion "lenses"! It is almost incomprehensible that notwithstanding the time that has elapsed he should not have appreciated the absurdity of what he thus propounded; but in the letter now published not the faintest glimmer is shown of any recognition on his part that his statement was as absurd as an assertion that the power of a telescope depends upon whether it is encased in wood or brass.

But if Mr. Morland's want of appreciation of the principles of the subject with which he was dealing is surprising, what are we to say to Mr. Smith's letter, which contains the most astounding microscopical mare's nest propounded since the days of the old aperture controversy.

It is hardly credible, but it is the fact, that Mr. Smith now justifies his original criticisms on the diffraction theory, and which we ventured to describe as "terrible nonsense," by the statement that that theory rested on objectives of low apertures, and that subsequently "the aperture of objectives has been increased by nearly one-half," so that adherence to the theory in the present day is "nothing better than superstition."

The first remark on this statement is that when the diffraction theory was propounded, we had not merely dry objectives with a theoretical maximum aperture of 1.0 N.A., but water-immersion objectives with 1.33 N.A., so that in the advance to 1.52 N.A. there is an increase not of nearly one-half or 50 per cent., but of 15 per cent. only. The second remark is that Mr. Smith is by his own admission wholly unaware that the theory was restated by Prof. Abbe *after* homogeneous-immersion objectives had come into use, and that in 1882 it was again developed by him in the fullest detail.‡

The letter of "A Member of both Societies" points the moral to

\* Eng. Mech., xlviii. (1888) p. 178.

† Ibid., p. 159.

‡ Mr. Smith's idea as to Prof. Abbe in 1875 "never having dreamt of the possibilities of the present objectives" is still more comical when it is considered what has been published in this Journal by Prof. Abbe on that very point, and the same remark applies to his views on "doubling the illuminating power," and "observing by direct light."

what at the best is a very humiliating chapter so far as microscopical optics is concerned. "A Member" insists that when Societies print rubbish in their Proceedings such comments as we made are beside the mark. Let us look at the matter by means of a parallel case.

Suppose a Fellow read a paper at the Astronomical Society refuting Newton's theory of gravitation on the ground that the premiss with which he started was wrong—that the apple fell to the ground simply because it got loose from the stalk, without which it would not have fallen. Can it be seriously suggested that the Society, as a Society, would not very properly incur serious discredit for printing such a paper in their Transactions? Is it conceivable that any astronomer would venture to write as "A Member" does, that "If no paper is to appear in any journal because some one or other, and perhaps very rightly, may consider it rubbish, most Societies had better give up printing their proceedings altogether; and if the opinions of an author, under his own signature, and controverted at the time of reading, are to be fathered upon a whole Society, either some animus exists or editorial craft must be in a poor way!"

It is especially to the Society who print nonsense that the complaint must be addressed, because it is they who are in reality the offenders. To the end of time there will be authors who will write with an air of transcendent knowledge on subjects of which they know nothing, and who will make similarly absurd mistakes to those of Mr. Morland and Mr. Smith. If the matter rested there it would be of small consequence—an affair of only passing amusement. But when it comes to publication it is a very different question. Not only are the readers of the papers misled, but microscopical science itself is degraded and disgraced, and made a laughing-stock in other scientific circles.

There is no possible reason why a Microscopical Society should be less jealous of its good name and credit than any other learned Society; and so long as we have any share in the conduct of this Journal we shall spare no effort to prevent the publication by any recognized microscopical authority of views which whether by ignorance or only wrong-headedness, are what we have described as terrible nonsense. We are glad to note that the tone in which the authors write in their recent letters sufficiently shows that when they next write a microscopical paper they will take much more care than they did with the last, in order to avoid the comments it has been our duty to make, so that even in that quarter some good will have been accomplished; the similar feeling displayed in another direction by "A Member" leads us also to the hopeful conclusion that even if similar authors should hereafter be found, yet that we have seen the last of any reproduction in print of such lamentable papers as those on which we have commented.

*Amphipleura pellucida.*

[Criticism, by Delta, of Mr. Nelson's note, *ante*, p. 809, and remarks by T. F. S., E. M. Nelson, Delta, and Jack.]

*Engl. Mech.*, XLVIII. (1888) pp. 117, 138, 159, 178, 199 (1 fig.),  
219 and 260 (4 figs.).

D'AGEN, E.—Initial Magnifying Power of Microscope Objectives.

*Engl. Mech.*, XLVIII. (1888) pp. 178-9.

HASSELBERG, B.—Über eine Methode die Brennweite eines Linsensystems für verschiedene Strahlen mit grosser Genauigkeit zu bestimmen. (On the method of determining with great accuracy the focal length of a system of lenses for different rays.)

*Bull. Acad. Imp. Sci. St. Pétersbourg*, XXXII. (1888) pp. 412-34.

- KERBER, A.—Bestimmung der Hauptbildebene und Prüfung der Korrektionszustandes optischer Systeme. (Determination of the principal image-plane and testing of the correction-condition of optical systems.)  
*Central-Ztg. f. Optik u. Mech.*, IX. (1888) pp. 205-8 (4 figs.).
- NELSON, E. M.—A simple Correction for Curvature of Image.  
*Engl. Mech.*, XLVIII. (1888) pp. 259 (2 figs.).

## (6) Miscellaneous.

- B., J. E.—Review of Tripp's 'British Mosses.'  
[“The author wisely advises her readers to avoid as much as possible the use of lenses.”(?)]  
*Journ. of Bot.*, XXVI. (1888) p. 351.
- DOLBEAR, A. E.—The Art of Projecting; a Manual of Experimentation in Physics, Chemistry, and Natural History, with the Porte-Lumière and Magic-Lantern.  
New ed., vi. and 178 pp., 119 figs., 8vo, Boston, 1888.
- FABRE-DOMERGUE.—Premiers principes du Microscope et de la Technique Microscopique. (First principles of the Microscope and microscopical technique.)  
250 pp. and figs., 12mo, Paris, 1888.
- FLESCHE, M.—Über den Einfluss der neueren Verbesserungen auf die Anschaffung eines Mikroskopes seitens des Arztes. (On the influence of modern improvements on Microscopes for medical men.)  
*Correspondenzbl. f. Schweizer. Aerzte*, XVII. (1888) p. 458.
- LEHMANN, O.—Molekularphysik mit besonderer Berücksichtigung mikroskopischer Untersuchungen und Anleitung zu solchen, sowie einem Anhang über mikroskopische Analyse. (Molecular physics, with special reference to microscopical investigations, and a guide thereto, as well as an appendix on microscopical analysis.)  
Vol. I., x. and 852 pp., 5 pls. and 375 figs., 8vo, Leipzig, 1888.
- MAYALL, J., JUN.—The Modern Microscope. I, II.  
[Cantor Lectures at the Society of Arts, 1888.]  
*Journ. Soc. Arts*, XXXVI. (1888) pp. 1149-59 (19 figs.), 1164-72 (7 figs.).
- ROYSTON-PIGOTT, G. W.—Microscopical Advances. XXXIX., XL.  
[Attenuated lines, circles, and dots.]  
*Engl. Mech.*, XLVIII. (1888) pp. 209 and 249 (1 fig.).

## β. Technique.\*

## (1) Collecting Objects, including Culture Processes.

**Agar-agar for Cultivation.**†—Dr. Richter gives a method for making agar which avoids to a great extent the difficulty of dissolving this medium in water. While the meat (250 grm.) for the infusion is macerating in water, into a flask holding about 250 ccm. are poured 10 grm. of agar finely chopped up and 150 ccm. of Moselle wine. Having been allowed to soak for a couple of hours, they are heated up to boiling-point in a water-bath. When the pieces are dissolved the agar-wine is set aside to cool. Next morning it is again liquefied in a water-bath and neutralized with carbonate of soda. The gelatin-meat-infusion, 2 per cent. gelatin, is then prepared in the usual way. When ready the agar wine is added to it, the mixture boiled for a quarter of an hour, and the whole filtered while hot.

The fluid (20-30 ccm.) which flows through at first is somewhat cloudy, but afterwards becomes quite clear. If cloudy the filtrate must

\* This subdivision contains (1) Collecting Objects, including Culture Processes; (2) Preparing Objects; (3) Cutting, including Imbedding and Microtomes; (4) Staining and Injecting; (5) Mounting, including slides, preservative fluids, &c.; (6) Miscellaneous.

† Berlin Klin. Wochenschr., 1887, p. 600.

be re-filtered. In order that the mass may have the proper degree of consistence it is necessary to use only 350 c.cm. of water in making the meat infusion instead of 500, in view of the addition of the 150 c.cm. wine.

All kinds of microbes thrive excellently on this medium.

**Albumen of Plovers' Eggs as Nutrient Medium for Micro-organisms.\***—Dr. D. Dal Pozzo prepares the albumen of plovers' eggs in the following way. The egg is first carefully cleaned externally, and then, having been opened, the thin albumen which runs out is received into a sterilized vessel. To this one-fourth of water is added, and then the medium is poured into test-tubes, &c., where it is discontinuously sterilized, and allowed to set obliquely. From one egg four or five tubes may be filled. If necessary the medium may be modified with glycerin, dextrin, paste, &c. The thicker portion of the albumen surrounding the yolk may also be made use of by diluting it with water, and even with glycerin; it is then filtered and treated as before. Discontinuous sterilization is not absolutely necessary, as the albumen is always free from micro-organisms.

The albumen mass may also be used for the production of plates. The inoculating matter is finely disseminated throughout the albumen, and the plate is then dried over sulphuric acid, and the micro-organisms developed in a moist chamber at ordinary temperatures.

**New Method for Cultivating Anaerobic Micro-organisms.†**—Dr. H. Buchner's method consists in absorbing the oxygen by means of pyrogallic acid. There results an atmosphere of nitrogen and a little carbonic acid mixed with a trace of carbonic oxide.

The apparatus is shown on a reduced scale in fig. 181. The outer tube is usually made 22–24 cm. long and 3 cm. wide, the inner tube having corresponding proportions. In the bottom of the outer tube is placed 1 gm. of dry commercial pyrogallic acid, and on this by means of a pipette are poured 10 c.cm. of a 10 per cent. solution of caustic potash. The smaller tube containing the previously inoculated gelatin, &c., is then placed within the larger one, and prevented from reaching the bottom by means of a wire stand. The smaller tube is plugged with cotton wool, and the outer one with a caoutchouc bung.

If the air space in the outer tube amount to 100 c.cm., the quantity of pyrogallic acid to 1 gm., and that of the potash solution to 10 c.cm., then the absorption of oxygen is completed in an incubator at a temperature of 37° in 24 hours. If the temperature be only 20° C., then it takes about two days to remove the oxygen entirely, while at 0° C. the absorption is very slow.

Frequent shaking of the pyrogallic acid produces of course a quicker absorption, and the addition of the alkali boiling hot accelerates the action. This method is said to save much time and labour in the laboratory.

FIG. 181.



\* Med. Jahrb., 1887, pp. 523–9.

† Centralbl. f. Bakteriol. u. Parasitenk., iv. (1888) pp. 149–51 (1 fig.).  
1888.

**Milk as a Medium.\*** — Fr. M. Raskin has made an elaborate series of experiments on the culture of pathogenic micro-organisms on a firm and transparent basis prepared from milk. From milk three kinds of culture-media may be obtained, (1) where casein is retained, (2) where it is replaced by peptone, or (3) by sodium albuminate. The investigator describes the preparation of milk-peptone-gelatin, milk-peptone-agar, milk-casein-gelatin, milk-casein-agar, milk-albumen-gelatin, and milk-albumen-agar. The media proved to be very suitable. Eight species of Bacteria were found to flourish, *Bacillus mallei*, *B. typh. abdominalis*, *Komina bacillus cholerae asiaticae*, *B. tussis convuls.*, *Staphylococcus pyogenes albus*, *Steph. pyog. aureus*, *Bacillus anthracis*, *Pneumococcus friedländeri*.

**Cultivation of Bacillus Tuberculosis on Potato.†**—Dr. A. D. Pawlowsky cultivates the bacillus of tubercle on potato as follows. Into narrow test-tubes, of the shape devised by Roux, are placed slips of potato. These are then sterilized for half an hour at 115°. When withdrawn from the steamer, the tubes are placed at an angle of 30°, in order to get cool, and also to drain. The potato is then inoculated, the tubes plugged and kept at a temperature of 39°.

After a dozen days' incubation the culture appears. It is whitish and glossy, and shows up distinctly against the yellow colour of the potato. In 5 to 6 weeks the surface is covered with greyish-white granulations. If glycerinated potato be used, the bacillus seems to develop with greater rapidity. The pathogenic properties of the bacillus are quite maintained, rabbits inoculated therewith die in 18 days.

The author is of opinion that the reason why other experimenters have failed to propagate the bacillus on potato, is that they have failed to recognize that humidity is an essential condition of the life of this microbe.

**Cultivation of Anaerobic Microbes.‡**—M. E. Roux describes some apparatus for cultivating anaerobic microbes. For cultivating in liquid media, in carbonic acid, or other gases the author uses Pasteur's double tubes, the open ends of which unite in a common narrow glass tube, besides which there is an additional tube at the side for filling purposes. The apparatus having been sterilized, the one test-tube is filled through the side tube with the inoculated nutrient solution, the other with sterile solution, after which the side tubes are melted up. Through the common exit tube the flask is evacuated with an air-pump and then filled with the gas desired. The connecting tube is now melted up. The nutrient tube is for control purposes, but afterwards may be used for another inoculation.

The simple plan for cultivating anaerobic microbes in solid media is to fill completely pipette-like vessels with gelatin nearly boiling, and then to melt up the ends. The gelatin is freed from air by the boiling. The tubes are inoculated by breaking off an end and then inserting the platinum needle, after which the end is melted up again. Another method employed is to have test-tubes with a narrow neck and then introduce the gas by means of a capillary tube passing through the cotton-wool plug into the gelatin. This done, the neck is melted up.

\* Biol. Centralbl., viii. (1888) pp. 462-70.

† Ann. Institut. Pasteur, ii. (1888) p. 315.

‡ Ibid., 1887, No. 2.

The author also uses test-tubes 25 cm. long and 3 cm. broad, ending in a narrow tube 10–15 cm. long, which serves to connect with the air-pump and gasometer. When the tubes are filled with a small quantity of agar or gelatin they are inoculated, evacuated of air, and then filled with the selected gas. This done, the tube is melted up and the tube laid in the horizontal position.

An original experiment of the author's in anaerobic cultivation was to use *Bacillus subtilis* as an agent to use up the oxygen. The gelatin was boiled up in a tube with a narrow neck, then set by immersing in ice-water, and at once inoculated. The inoculated gelatin was then covered with a layer of agar inoculated with the *B. subtilis*, whereupon the tube was melted up. When the aerobic *B. subtilis* began to develop it absorbed the free oxygen present in the tube, and thereby created, for the germs of the anaerobic microbes lying below, the proper condition for their development.

Cultivation of the "Typhus" Bacillus in coloured nutrient media.\*—Herr Birch-Hirschfeld has applied the method of staining Bacteria in the living condition to the study of the morphology and development of the typhoid Bacillus. The staining of the living Bacteria was effected partly in drop-cultivations and partly in test-tubes. For making the bouillon drop-cultures the author used the ordinary hollow-ground slides. The cover-glass was fixed on a rim made out of 5 parts vaselin and 1 part paraffin. This rim was run on the slide with a turntable while the mixture was hot. This kind of rim allows the cover-glass to be easily lifted up, and an incubation does not run into the drop. Instead of the dyes usually adopted the author employed phloxin-red, a pigment which does not cause, like fuchsin, methyl-violet, &c., a granular precipitate to be deposited in the bouillon. Of a sterilized watery 1 per cent. solution of phloxin-red 1 ccm. is added to 6 ccm. of sterilized slightly alkaline bouillon. Of this the drops are made, and in it the typhoid Bacillus grows up coloured a bright red. The spores, too, which remain unstained in cover-glass preparations, are here (typhus and anthrax) brightly stained, and often more strongly than the rest of the protoplasm. If the bouillon solution be less stained than in the foregoing the spores only are stained.

Benzo-purpurin in similar quantities is still more suitable for the purpose than phloxin-red. This dye stains the spores brown.

One of the positive results, according to the author, of this method is to set at rest the disputed question of endogenous spores in typhoid Bacillus.

The author furthermore showed from the example of anthrax Bacillus that Bacteria bred in this way are unaffected both in development and virulence.

New Method of cultivating Bacteria in Coloured Media for Diagnostic Purposes.†—Dr. Noeggerath constructed a mixture of anilin dyes to correspond as nearly as possible with the spectrum colours. Of these dyes strong watery solutions were made, and then mixed in the following proportions:—Methylen-blue, 2 ccm.; gentian-violet, 4 ccm.; methyl-green, 1 ccm.; chrysoidin, 4 ccm.; fuchsin, 3 ccm. This mixture was then diluted with 200 ccm. water and added unfiltered to the gelatin in the proportion of 7–10 drops to about 10 ccm. of the latter. The whole

\* Arch. f. Hygiene, vii. (1887) p. 341.

† Fortschr. d. Med., vi. (1888) p. 1.

having been boiled twice or thrice in a test-tube was poured out on a plate, and when it had set, inoculated with the microbes to be examined. With the development of the microbes certain colours may appear; for example, *Streptococcus pyogenes* forms an orange-red streak in the midst of the dark-grey gelatinous mass. As this colour was not in the original mixture, the author regards it as a product of the vital activity of the Bacteria.

**Improvement in Plaut's Flasks for sterilizing water.\***—Dr. H. Plaut finds that his sterilizing bottles are subject to the inconvenience of an escape of the water when the closure of the stopper and neck is quite air-tight. This is obviated by using a cork stopper, and by drawing out the glass tube as far as the level of the water. When sterilization is completed the glass tube is pushed back again.

**Fire-proof Cotton-wool Plug for Test-tubes.†**—Dr. S. Bartoschewitsch has invented a modification of the cotton-wool stopper which consists in moistening it, before sterilization, with silicate of potash. Any shape can then be given to the plug with the fingers. The mass dries during sterilization, and in this way is produced a fire-proof casing which is difficult to remove from the plug, and can be used again a thousand times. This modification has the further advantage of preventing the nutrient medium from drying, and is much more convenient than the caoutchouc capsule in vogue.

- BORDONI-UFFREDUZZI, G.—La Coltivazione del bacillo della lebbra. (The culture of the leprosy bacillus.) *Arch. Sci. Med.*, XII. (1888) p. 53.
- MANGERI, C.—Sulla preparazione della gelatine all' agar-agar. (On the preparation of gelatin from agar-agar.) *Gazz. degli Ospitali*, 1888, pp. 179-80.
- ROUSSELET, C.—On some methods of Collecting and Keeping Pond-life for the Microscope. *Trans. Middlesex Nat. Hist. and Sci. Soc.*, 1888, pp. 64-71.
- SCHIMMELBUSCH, C.—Eine Modification des Koch'schen Plattenverfahrens. (A modification of Koch's plate process.) *Fortschr. der Medizin*, 1888, pp. 616-9.
- SOYKA, J.—Bakteriologische Untersuchungs-methoden mit besonderer Berücksichtigung quantitativer bakteriologischer Untersuchungen. (Bacteriological investigation methods, with special reference to quantitative bacteriological investigations.) *Prag. Med. Wochenschr.*, 1888, pp. 429-30.

## (2) Preparing Objects.

**Methods of Examining Blood-corpuses.‡**—According to Prof. A. Mosso there are three principal reagents suitable for the examination of blood. The first of these is sodium chloride 0.75 per cent. solution, and this is unsatisfactory, as it alters and decolorizes many corpuses. This negatives the advantages which this salt possesses in allowing the examination of blood in the fresh condition. Against the use of serum and iodized serum there are also weighty objections.

The other two reagents are perchloride of mercury, and osmic acid. These fix and solidify the blood, but the former suffers from the inconvenience of coagulating the serum. Perchloride of mercury is used chiefly according to the formulæ of Pacini and Hayem. The solution of the former is mercury perchloride 1 gr.; sodium chloride 4 gr.; distilled water 200 gr.

Hayem modified Pacini's formula as follows:—Distilled water

\* *Centralbl. f. Bakteriol. u. Parasitenk.*, iv. (1888) pp. 152-3. † *Ibid.*, p. 212.

‡ *Arch. Ital. Biol.*, x. (1888) pp. 40-8.

200 gr.; sodium chloride 1 gr.; sulphate of soda 5 gr.; perchloride of mercury 0·5 gr.; glycerin 28°.

The chief objections to mercurial solutions are, according to the author, that they do not prevent all the corpuscles from becoming altered, and that they always produce a decoloration of the red corpuscles.

Osmic acid used in 1 per cent. solution preserves blood-corpuscles better than any other known reagent, and does not precipitate the albumen like sublimate. It fixes the leucocytes in their natural condition, and though they become granular, they remain transparent, and preserve their proper and characteristic outlines.

**Preserving Blood-corpuscles for Microscopical Examination.\***—The following method of preparing permanent microscopical specimens of blood-corpuscles is extremely simple, and in Mr. R. Leigh's hands has yielded very satisfactory results.

A thin film of blood on a cover-glass is gently dried, and inverted, for half an hour or more, into a covered capsule containing a half-saturated solution of safranin in absolute alcohol. The loosely adhering stain is then washed off by a stream of distilled water, after which the specimen is again thoroughly dried, and mounted either in Canada balsam, liquefied by heat, or thinned by turpentine.

With human blood the corpuscles are stained a beautiful clear pink colour, and in non-mammalian blood the nuclei are stained dark pink, while the rest of the red corpuscles are lightly tinged. The specimens which were made three months before have retained their colour perfectly.

**Methods for Investigating the Structure of the Central Nervous Organs in health and disease.†**—In his 'Introduction to the Study of the Structure of the Central Nervous Organs in health and disease,' Dr. H. Oberstein recommends the dissociation method of Stilling. Harden in Müller's fluid, and then place in absolute alcohol. Then immerse in artificial wood vinegar for several weeks (glacial acetic acid 200 gr., water 800 gr., kresote 29 drops). The preparations can, after being treated with oil of cloves, be mounted in balsam. If continuous series of sections be required, the tissue should be hardened in bichromate of potash. Begin with a 1 per cent. solution, change very often, gradually strengthening to 2 or 3 per cent. (time 6–8 weeks). In an incubator at from 35°–45° hardening is effected in 8–14 days. Special care is necessary for hardening spinal cord. If the preparations are to be kept in the bichromate solution after having been hardened, the strength should be 0·1 per cent. Hardening may be hastened by the addition of 20 to 30 drops of a 1 per cent. solution of chromic acid to the solution of the salt. When hardened the preparations are to be washed and then transferred to 50 per cent., and finally to 95 per cent. spirit. Müller's and Erlitzki's fluids and bichromate of ammonia are condemned. The best fixative for the delicate structures is a modification of Flemming's solution (Fol):—osmic acid 1 per cent., 2 vols.; chromic acid 1 per cent., 25 vols.; acetic acid 2 per cent., 8 vols.; water 68 vols. After being in this fluid for 24 hours, the pieces are thoroughly washed and then placed in 80 per cent. spirit.

\* Journ. Anat. and Physiol., xxii. (1888) p. 497.

† 8vo, Leipzig u. Wien, 1888, 406 pp. 178 figs. Cf. Zeitschr. f. Wiss. Mikr., v. (1888) pp. 203–7.

For staining, Gerlach's ammonia-carminé is most recommended. The sections may be stained in 3 to 5 minutes, if placed over a water-bath filled with boiling water. Löwenthal's picrocarminé, Czokor's cochineal-alum solution, Bismarck brown, nigrosin, and Grenacher's alum-carminé are also mentioned favourably. For staining the nerve-sheaths, osmic acid (osmic acid 1 per cent. + glycerin + ammonia), and Golgi's sublimate and silver methods are also alluded to. Palladium and gold and Weigert's method are mentioned.

**Methods for Examining the Structure of the Cerebrospinal Nerves.\***

—M. L. Petrone found that the two following methods were the best for investigating the structure of the intracranial and spinal nerves:—

(1) Bichromate of potash, or Müller's fluid, and nitrate of silver. The pieces of nerve were kept in a 2 per cent. solution of the bichromate, or in Müller's fluid, frequently changed, for at least two months. The hardening was accelerated by keeping the fluids at a temperature of about 25° C. After this the pieces are placed for 24 to 48 hours in 0.75 per cent. solution of nitrate of silver and kept in a warm place. The sections are washed several times, to free them of excess of nitrate of silver, with ordinary spirit, and finally with absolute alcohol. They are then passed through creosote and turpentine oil successively, and having been placed on a slide, are covered over with dammar merely (no cover-glass). The disadvantages of this method are the copious precipitate on the surface of the sections and the inconstancy of the staining.

(2) Bichromate of potash, or Müller's fluid, and sublimate. The pieces are first hardened as before, and then are placed by degrees in 0.35–0.5 per cent. sublimate solutions, which must for the first 10 days be renewed daily, and afterwards every third or fifth day. In this solution the pieces must remain for at least two months. The further treatment is as before, except that the copious use of water is required before the sections are placed in spirit in order to prevent the precipitate on their surface.

The foregoing methods may also be used for isolation of the elements:—(1) The pieces hardened in bichromate are thoroughly stained with ammonia-carminé, picrocarminé, chinolin, or methylen-blue, and then dissociated in glycerin or some other suitable medium. (2) The preparations are macerated in Ranvier's one-third spirit. Small pieces are then shaken up in a test-tube with a little water, to which picrocarminé and afterwards osmic acid are added.

**Making Preparations of Bone and Teeth and retaining their soft parts.†**—Dr. L. A. Weil takes only fresh, or nearly fresh, teeth, and in order to allow reagents and stains to penetrate into the pulp cavity, divides the tooth immediately after extraction with a sharp fret-saw, below the neck, into two or three pieces, "allowing water to trickle over it the while." The pieces are then laid in concentrated sublimate solution for some hours to fix the soft parts. After this they are washed in running water for about one hour, then placed in 30 per cent. spirit, which in 12 hours is changed to 50 per cent., and again after a similar period for 70 per cent. Then, in order to remove the black sublimate precipitate, the teeth are laid for twelve hours in 90 per

\* Internat. Monatschr. f. Anat. u. Physiol., v. (1888) Heft. i.

† Zeitschr. f. Wiss. Mikr., v. (1888) pp. 200–2.

cent. spirit, to which 1.5-2.0 per cent. tincture of iodine has been added. The iodine is afterwards removed by immersion in absolute alcohol, until the teeth become white.

For staining, alcohol or aqueous solutions of borax-carminé gave the best results. From the absolute alcohol the teeth are removed to running water from 15 to 30 minutes, and then placed in the stain. In the watery solution of borax-carminé they remain one or two, in the spirituous two or three, days. They are then transferred to acidulated 70 per cent. spirit (70 per cent. spirit 100 ccm., acid. muriat. 1.0) in which they remain, the watery ones stained at least 12, the alcohol-stained ones 24 to 36 hours. This done, they are immersed for about 15 minutes in 90 per cent. spirit, and then for half an hour in absolute alcohol, after which they are transferred to some ethereal oil for twelve or more hours.

The ethereal oil is then quickly washed off the objects with pure xylol, and then they are placed for at least 24 hours in pure chloroform. After this they are passed into a solution of balsam in chloroform. The balsam is prepared by drying, in a water-bath heated gradually up to 90°, for eight hours or more, until when cold the mass will crack like glass on being punctured. Of this balsam so much is added to the chloroform as to make a thin solution, in which, as before mentioned, the teeth lie for 24 hours. After this time as much balsam is added to the solution as will dissolve. When no more balsam will dissolve, the teeth and a sufficiency of the balsam are poured into a vessel and heated up to 90° in a water-bath until the mass when cold shall be hard as glass. When the balsam is sufficiently set the teeth are carefully picked out, placed in a vice, and thin discs are cut from them with a fret-saw, water being allowed to trickle over them the while, and then they are ground in the usual way. The preparations are mounted in chloroform-balsam.

**Preparing large Sections of Lung.\***—Dr. G. S. Woodhead makes large sections of lung for demonstrating morbid appearances as follows:—Make the first incision through the lung in the direction in which you wish to have your sections. The second incision is made parallel to the first and not more than half an inch from the first. The section should then be placed in a flat dish on a layer of lint, and covered with several layers of lint, and over this a piece of plate-glass to keep the section flat and submerged. After being five or six weeks in the Müller, the sections are washed for about 24 hours in water. The slice is then placed in a mixture of 5 parts mucilage (B.P.) and 4 parts of syrup made by boiling 20 oz. of sugar in a pint of water. In winter 3 parts of syrup will suffice. Two drops of carbolic acid to the ounce prevent formation of fungi. After soaking in this for 48 hours or more, the slice is taken out for sectioning, dried with a soft cloth, then placed in B.P. mucilage for a few minutes, and then transferred to the freezing plate of the microtome. The microtome used is a modification by Dr. A. Bruce of the best features of the Hamilton and Williams microtomes. From time to time the slice must be banked up with gum, and when nearly frozen pare down the tissue to the level of the rails with a long thin knife. In front of the microtome place a flat white dish filled with warm distilled water, and in which is also placed a flat glass, larger than the slice, and which will eventually serve as

\* The Microscope, viii. (1888) pp. 272-5.

cover-glass. The first complete section which finds its way into the white pan placed at a level of about one inch below that of the sections, is removed on the cover-glass to a dish of distilled water, wherein it remains for some hours. The sections are then stained with alum-carmin, picrocarmin, or ammonia-carmin. With picrocarmin rapid staining on the slide is best. In alum-carmin the section on the cover-glass may be left all night. Then transfer to distilled water to remove alum crystals.

Some of the unstained sections may be cleared up by Hamilton's liquor potassæ method. Having been thoroughly washed, pour over the surface of the sections with a pipette a solution of liquor potassæ 1:4 water. To imbed and mount take a quantity of gelatin, wash and cover with a saturated solution of salicylic acid. Soak all night, then pour off superfluous water and heat over a water-bath until the whole is thoroughly melted. To every one part of this add two parts of glycerin. Heat over water-bath, keeping it stirred until the whole is thoroughly mixed, strain through a piece of close flannel into a flask in which it may be reheated as required. Having allowed most of the water to drain away, the slide is placed on a level stand, and a thin layer of warm glycerin jelly run slowly and gently over the surface by means of a pipette; then set aside to cool. To finish off the preparation, the slide on which the section is to be mounted is placed on three or four pieces of cork over a water-bath until it is warmed through. It is then transferred to the tripod, and a quantity of jelly is passed on to the centre and gradually on to the end nearer the manipulator. The cover-glass is then gently lowered down, the near end first. The jelly on the cover-glass keeps the section in position long enough to allow of the cover-glass coming into its place. The slide usually retains sufficient heat to melt away all superfluous jelly. Should this not be the case, the whole slide may be again heated and the extra mounting medium gently squeezed out. If there be any surplus at the margin of the cover the slide may be left for some time without further treatment. To preserve the specimen, remove the extra jelly with a knife, wipe carefully first with a moist, and afterwards with a dry cloth. Then paint round the margin several layers of benzol balsam. This must be done at once after the superfluous jelly has been scraped away, otherwise air-bubbles get in owing to the jelly becoming dry. It is convenient to mount these slides in common wooden frames.

**Cleansing the Intestine of many animals of sand.\***—Dr. Küenthal remarks that the grit present in the gut of many animals, and which is due to their way of life, prevents the preparation of thin sections. Such is the case with the earthworm. The author advises that the animal be first washed clean and then be placed for some time in a tall glass vessel which has been filled up with bits of moistened blotting-paper. The worm gradually evacuates the earthy particles from the gut and fills it instead with paper.

**Killing contractile Animals in a state of extension.†**—M. L. Roule divides the contractile animals into those which contract rapidly, like Actiniæ, Hydroids, Bryozoa, and Ascidiæ, and those which contract more slowly, like *Acyonium* and *Veretillum*. The latter

\* Tagebl. 60. Versamml. Deutscher Naturf. u. Aerzte: Wiesbaden, 1887, p. 259.

† Arch. Zool. Expér. et Gén., vi. (1888) pp. v.-vii.

may be best killed by being plunged in a quantity of E. van Beneden's fluid, which consists of a saturated solution of corrosive sublimate in distilled water 3 parts, and crystallizable acetic acid 1 part. Specimens should be left in this fluid for from five to twenty-five minutes according to their size, and then washed in pure water. They should then be placed in alcohol of 45°, then 60°, 70°, and finally 80°. For histological purposes 90° and absolute alcohol should also be used. If necessary the quantity of acetic acid may be diminished.

For animals which contract rapidly it is best to use ordinary alum. Specimens are put in glass dishes with sufficient water to enable them to expand; when expanded some crystals of alum are quietly put near them; as these dissolve slowly the animals are killed gradually. Several hours are necessary for this reagent. They are then washed clean of alum, fixed with dilute solutions of Van Beneden's fluid; then washed with water and treated with a series of various strengths of alcohol.

**Preparation of Embryos of Asterias.\***—Mr. J. W. Fewkes, in his investigations into the development of *Asterias*, killed the young forms in 35 per cent. alcohol; they were then rapidly passed through various grades (50, 70, 90 per cent.) to absolute alcohol. They were then clarified in clove-oil, and mounted in balsam. Those which were stained were carried from 70 per cent. alcohol into Grenacher's alcoholic borax-carmine, washed, afterwards placed in from 90 per cent. to 100 per cent. alcohol, then removed to clove-oil or balsam. The preparations mounted without staining show very well the relation of the plates to each other, but it is necessary to use a staining fluid to bring out the tissues of the organs in the immediate vicinity of the calcareous skeleton. Mr. Fewkes, who used chloroform for clarifying purposes in his study of *Amphiuva*, finds that clove-oil is to be preferred.

**Investigation of Generative Products of Spongilla.†**—Herr K. Fiedler has fixed and preserved the pieces of *Spongilla*, which he examined, with absolute alcohol and a mixture of alcohol and sublimate; the latter consisted of one part of cold saturated sublimate solution, one part of 70 per cent. alcohol, and one part of distilled water. Kleinenberg's picric sulphuric acid and Flemming's chrom-osmium-acetic acid mixture were also used with satisfactory results. Pieces were stained with Grenacher's borax-carmine and Schweigger-Seidel's hydrochloric acid and carmine. Smaller pieces were well stained with Böhmer's hæmatoxylin and with picrocarmine. Imbedding was generally effected in paraffin, rarely in celloidin. The thickness of the sections varied between 1/50 and 1/160 mm. Lyons blue was found to be especially useful in staining sections, for on being washed with ammoniacal alcohol the blue coloration was limited to the yolk-granules of the egg, and this showed up the red-stained nuclear structures. Sections of tissues preserved in picro-sulphuric acid showed, when stained with hæmatoxylin, a double coloration, the nuclei being of a bluish-violet and the vitelline constituents of a yellowish or feebly red tone.

**New Method for Marking Root-hairs and for Hardening and Staining Plant-cells.‡**—In his work on 'The Relations between Func-

\* Bull. Mus. Comp. Zool. Camb. U.S.A., xvii. (1888) pp. 3-4.

† Zeitschr. f. Wiss. Zool., xlvii. (1888) pp. 86-8.

‡ 'Ueber die Beziehungen zwischen Function und Lage des Zellkerns bei den Pflanzen,' Svo, Jena, 1887, 135 pp. (2 pls.).

tion and Position of the Cell-nucleus in Plants' Dr. G. Haberlandt gives the following new methods.

In order to control the growth of the root-hairs and to be able to measure their increase (it not being possible to mark these forms artificially), the germling was placed in the moist chamber on a slide, and then fine dry rice-starch was blown against the root-hairs and thereupon the cover-glass imposed. The starch-granules adhere to the sticky surface of the hairs and form marks placed at irregular intervals. The measurements were made under a low power by means of an ocular micrometer. The experiments frequently fail because the tender sensitive hairs very frequently stop growing after they have been marked. Successes, however, were scored with *Cucurbita Pepo*, *Pisum sativum*, *Polygonum Fagopyrum*, *Helianthus annuus*.

For studying the cell-nucleus, *Vaucheria* filaments were cut in two, and 20-30 minutes afterwards placed in a 1 per cent. chromic acid solution and the nuclei eventually stained with picrocarmine. For examining the plasma-balls ejected by the wounded *Vaucheria* the plants were not cut up in water, but in a 5-10 per cent. sugar solution, and cultivated for three to seven days either in porcelain capsules or in hanging drops.

It may also be mentioned that the author repeatedly obtained good results with picrocarmine, dilute methyl-green and acetic acid, and with borax-carmin. Excellent preparations showing the lacteal vessels were obtained by laying pieces of the epidermis in borax-carmin for several to twenty-four hours, and after treating with hydrochloric acid-alcohol examining in glycerin. The nuclei of *Saprolegnia* were brought out by hardening in 1 per cent. chromic acid, carefully washing, and staining with hæmatoxylin. Spores of *Pertusaria* were first treated with alcohol and ether to remove the oil in the nuclei, then stained with picrocarmine or logwood.

**Preparation of Fresh-water Algæ.\*** — Dr. L. Klein proposes a modification of the ordinary method of preparing fresh-water algæ for microscopic examination. The use of any fluids, such as glycerin or potassium acetate, he has almost entirely abandoned, because of the time required in their preparation to secure their permanency, and the danger of injury to the cover-glasses in cleaning them. In those cases where a fluid is necessary, as when a single minute object lies in water beneath the cover-glass, he places a drop of 1 per cent. superosmic acid on the margin of the cover-glasses, and, after ten or twelve minutes, potassium acetate; this is blown under the cover-glass by means of a very fine glass tube. The hardening is effected by superosmic acid, and the closing by Canada balsam.

The solid substance preferred by Dr. Klein is Kaiser's glycerin-jelly, † viz. 1 part of very fine gelatin diluted with six parts of distilled water for two hours, and 7 parts by weight of chemically pure glycerin then added. To 100 gr. of this mixture 1 gr. of concentrated carbolic acid is added, and the whole warmed for ten minutes. In order to prevent shrivelling up the algæ must be hardened in superosmic acid before placing in the glycerin-gelatin.

For minute, and especially for unicellular algæ, Dr. Klein uses not

\* Hedwigia, xxvii. (1888) pp. 121-6.

† See this Journal, 1887, p. 694.

the fluid but vapour of superosmic acid, the alga to be hardened being placed in a hanging drop on a glass slide over the mouth of the flask containing the osmic acid. But this plan answers only when the object to be preserved occurs in the drop in considerable quantities. When it is solitary, or present only in very small numbers, the water in which it is contained must be partially evaporated in a watch-glass, a watch-glass containing from 5-10 drops of osmic acid being also placed in the evaporating-chamber; after the drops of the fluid have been partially evaporated dilute glycerin is added.

Glycerin-jelly is especially valuable as an imbedding material for such objects as are difficult to inclose in glycerin in consequence of their slipperiness.

**Simple Method for Fixing Cover-glass Preparations.\***—Dr. M. Nikiporow fixes fluids, e.g. blood, on cover-glasses by immersing them for one or two hours in a mixture of ether and absolute alcohol. The cover-glass is then taken out, and having been dried in the air, is stained by Ehrlich's method.

The process may also be used when micro-organisms are to be stained.

KLEIN, L.—*Beiträge zur Technik der Mikroskopischen Dauerpräparate.* (Contributions to the technique of microscopical permanent preparations.)

*MT. Bot. Vereins Freiburg*, 1888, Nos. 49 and 50, 7 pp.

LAMB, D. S.—Notes on the Technique of Frozen Anatomical Sections.

*Amer. Mon. Micr. Journ.*, IX. (1888) p. 205.

### (3) Cutting, including Imbedding.

**Cathcart Improved Microtome.**—This instrument (fig. 182) differs from the original Cathcart Microtome in the following points:—(1) The principal screw is of larger diameter than in the old form, and has a head of considerably greater size; (2) The wooden frame is made with a projecting part, by means of which the instrument may be clamped on *both* sides, and two clamps are supplied; (3) The freezing-plate is made of circular shape, is supported on three pillars, and is provided with a ledge to prevent the ether getting to the upper side of the plate; (4) The construction of the instrument has been so modified that it may be used both for specimens frozen in gum and those imbedded in paraffin or celloidin.

The increased size of the screw gives a more steady movement than was possessed by the older and smaller microtome, while the greater circumference of the screw-head enables the operator to impart a finer movement to the screw. The relation between the pitch of the screw and the circumference of its head is such, that if the edge be moved forward a quarter of an inch, an object will be raised one-thousandth of an inch; and if it be moved an eighth of an inch, the object will be raised the two-thousandth of an inch.

It is found that, when the instrument is clamped at both sides, less pressure need be applied at either side; and the tendency which the instrument had to turn upon the point of clamping, as on a pivot, is quite done away with.

In the original instrument, the plate was supported on two pillars, in order that as little heat as possible might be conveyed to the freezing-

\* *Zeitschr. f. Wiss. Mikr.*, v. (1888) p. 340.

plate from the body of the instrument. In the new instrument, the size of the three supporting pillars and screws is so much reduced that

FIG. 182.

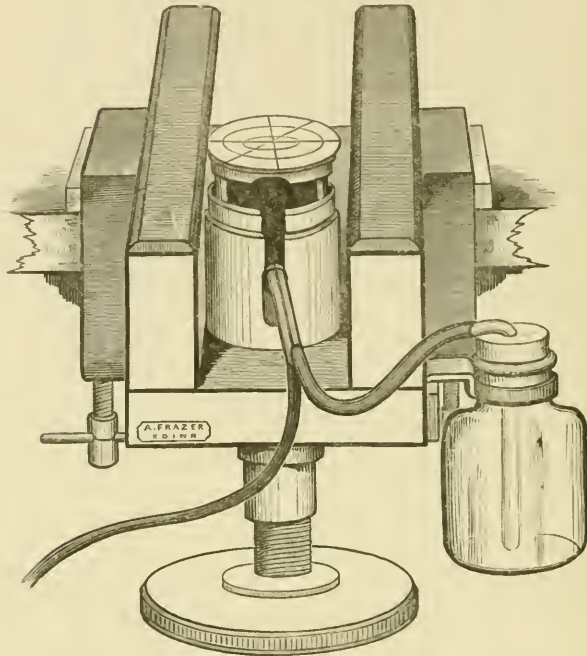

the conducting surface is not greater than in the old microtome. The arrangement for cutting imbedded sections consists of a tube (fig. 183) which fits the principal well of the microtome, and within which fits a hinged part similar to an ordinary vice. With the instrument are provided the means of preparing paraffin blocks for imbedding sections.

FIG. 183.

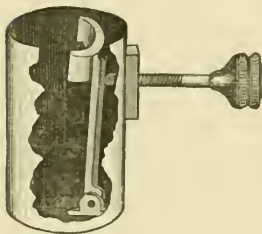

When it is intended to use the microtome for imbedding, the ether-spray, spray-bellows, and ether-bottle should be removed, and the freezing-tube, having been raised as far as possible by means of the principal screw, should then be withdrawn from the well. The imbedding-tube is now placed in the well, and, having been pushed down until it rests upon the point of the

large screw, it may be lowered to a convenient height by working the large screw backwards.

The instrument is made by Mr. A. Frazer, of Edinburgh.

**Thin Sections.**—In opposition to the note of the Editors of the 'Microscope' (*ante*, p. 671), Dr. J. E. Reeves contends\* that "the proper

\* The Microscope, viii. (1888) pp. 252-5.

thickness of the section is a matter to be wholly determined by the particular character of the tissue or object to be examined and studied. Of course, no one having any correct knowledge of tissue structure would think of attempting to cut a section of bone, or of the skin of the heel, to the same measure of thinness that would be necessary to demonstrate bacilli in a section of tuberculous lung."

"If coarse details only are required, then a thick section properly cleared, and a low-power objective, will answer the purpose in view; but when the finest possible details of a histological or pathological specimen are sought by the aid of a high-power objective, a section just thin enough to hold the tissue elements together will not be too thin—the thinner the better—provided the section has been handled from beginning to end in the highest style of the beautiful art. In other words, a very thin, evenly-cut section—the 1/3000 in.—is of no more use or value than a section the 1/50 in. thick, if it—the thinner section—has not been perfectly cleared up and well mounted."

In reply \* to Dr. Reeves's criticism, the editors "still insist that our sections must have a thickness that will include as many layers as can be *clearly* studied; for the details of a specimen cannot be observed unless it is thick enough to show the arrangement of its parts. As for studying the finest possible details, such as the structure of or changes in individual cells, no section, however thin, will serve the purpose. Other methods must then be employed."

BALTZAR, G., and E. ZIMMERMANN.—Mikrotom mit festem Messer und selbstthätigen Vorschub des Objekts. (Microtome with fixed knife and automatic movement of the object.)

German Patent, 12th March, 1888, No. 45,504.

CAMPBELL, D. H.—Paraffin-Einbettungsmethode für pflanzliche Objecte. (Paraffin imbedding methods for vegetable objects.)

*Naturwiss. Wochenschr.*, II. (1888) p. 61.

#### (4) Staining and Injecting.

**Methyl-green for observing the Chemical Reaction and Death of Cells.**†—Prof. A. Mosso used for his researches on the reaction between methyl-green and blood- or pus-corpuscles, a watery 1 per cent. solution of sodium chloride in which 0.2 per cent of methyl-green was dissolved. To observe the action of this solution on the red corpuscles it is only necessary to prick the finger, and touch a drop of the solution placed on a slide with the blood. This preliminary examination, made with an apochromatic 20 mm., aperture 1.30, oculars 4 and 12, was supplemented by observations in the moist chamber at periods of 6 and 24 hours. The result of these experiments showed that if cells were quite healthy or in their proper working condition they did not become stained, but if this condition became weakened they stained violet, then bluish-green, and finally green. Dead cells became coloured green at once.

The solution was also noted to have a toxic action indicated by the death of the cells, and their consequent staining, as their enfeeblement began and death took place. The cells used for the examination were red and white corpuscles of the blood of fishes, frogs, &c., cilia

\* *The Microscope*, viii. (1888) p. 248.

† *Arch. Ital. Biol.*, x. (1888) pp. 29-39.

from the branchiae of *Unio* and *Anodonta*, and spermatozoa. To the contractile protoplasm of vegetable cells methyl-green is also toxic (hairs from *Tradescantia virginica*, and spores of *Ulva lactuca*, a marine alga).

The author further found that methyl-green prevents the coagulation of blood. A solution of 0·5 per cent. methyl-green in 0·75 per cent. sodium chloride retards coagulation even in the proportion of 2 ccm. to 40 ccm. of blood, and if the amount be increased to 3 or 4 ccm. to 40 ccm. coagulation does not take place.

With regard to the chemical explanation of some of the foregoing facts, it was found that if the alkalinity of the cells be considerable, the methyl-green is destroyed, and consequently the violet staining of the cells is an index of diminished alkalinity.

**Nuclear Carmine Stain.\***—Dr. M. Nikiforow recommends the following method for making a carmine solution, which he says will keep for years, and while giving excellent results with nuclei in sections, may also be used for staining tissue *en masse*. Three parts of carmine, five parts of borax, and 100 parts of water are boiled together in a porcelain vessel. Ammonia is then added until the carmine has dissolved, the solution assuming a cherry-red colour. To this solution dilute acetic acid is added very carefully until the cherry-red colour has disappeared. Prepared in this way carmine is a thick, deeply stained (*sic*), odourless fluid, which will keep for a long time if a little carbolic acid be added to prevent the formation of fungi. Sections are stained in about 15 minutes, but may be left in the solution for 24 hours without over staining. If required for staining *en masse* the pieces must be left in the solution for several days, and when removed carefully washed. This carmine solution is especially suitable for preparations fixed in alcohol or osmic acid, or the chromic acid salts if not used for longer than two weeks.

**Staining Karyokinetic Figures.†**—Dr. L. Resegotti who, in conjunction with Prof. Martinotti, had previously shown that the mitoses of the nucleus may be demonstrated very well by means of safranin and chromic acid (see this Journal, 1888, p. 516), has recently extended his experiments to other anilin pigments and also to certain trade varieties of safranin. These varieties of safranin not only differ in colour and in specific weight, but also in solubility; for example, they are divided by the author into three classes, those which are soluble in spirit, those which are soluble in water, and those which are best dissolved by a mixture of spirit and water. In all 14 samples of safranin were examined, and all these gave positive results, but some varieties were better for the end in view than others.

Another difference noted is the resistance to decoloration by the chromic acid. This also varied with the different samples, but there is no note as to relation between the decoloration and solubility in water or spirit. Other anilin dyes which gave positive results were the hydrochlorate and acetate of fuchsin, dahlia, methyl-violet, gentian-violet, rubin, victoria blue, magenta red.

The author also made some experiments to see if the karyokinetic figures would not stain by substitution, but the only favourable results

\* Zeitschr. f. Wiss. Mikr., v. (1888) pp. 337-8.

† *Ibid.*, pp. 320-4.

he seems to have had come from a combination of methyl-violet or dahlia, with eosin or acid fuchsin. The sections hardened in absolute alcohol are stained with an aqueous or weak spirituous solution of methyl-violet for five minutes, they are then transferred to a very dilute solution of eosin in spirit, wherein they remain for one or two minutes. After this they are again treated with spirit and mounted in the usual way.

**Safranin as a Stain for the Central Nervous System.\***—It has already been pointed out, says Dr. M. Nikiforow, that safranin stains certain parts of the central nervous system in a characteristic way when the tissue has been hardened in chromic acid salts. Thus the medullary sheath of the fibre (erythrophilous substance) stains rose, while the nuclei of the nerves, glia cells, and blood-vessels assume a violet hue. This property of safranin is all the more important, because in disease, and even in the earlier stages thereof, the characteristic coloration is lost. The method of the author for manipulating the tissue in order to obtain a satisfactory result, as far as differentiation is concerned, is as follows:—The brain or cord is hardened in chromic acid salts (Müller's fluid or bichromate of ammonium). The chromic acid salts are not to be washed off with water, and the sections are to be transferred directly from spirit to the concentrated aqueous solution of safranin. The anilin water solution or a 5 per cent. carbolic acid solution of this dye may be used. It is advised to over-stain the sections or to leave them in the staining solution for 24 hours. After this the sections are removed to spirit, where the excess of stain is washed off. As soon as the grey substance begins to appear, and can be distinguished from the white matter, the section is lifted out and placed in a solution of a metallic salt, chloride of gold, or chloride of platinum, the strength of which is 1:500 and 1:1000. When a trace of violet begins to show in the grey substance the section is at once placed in water and thoroughly washed. After this it is placed in alcohol until the rose-violet of the grey substance is clearly distinguishable from the red of the rest of the tissue. It is next cleared up in oil of cloves, and the latter replaced by xylol, and finally the specimens mounted in balsam.

**Combining Weigert's Hæmatoxylin-copper Stain for Nerve-fibre with the use of the freezing Microtome.†**—Prof. D. J. Hamilton states that sections of brain of any size can be cut with the freezing microtome and stained to perfection with the copper and hæmatoxylin if the following method be adopted.

The brain should be hardened in Müller's fluid, the longer the better, those which have lain years in the fluid being best to work on. Human brain requires three to four months, and that of a small animal three to four weeks. When thoroughly hardened it is cut into perpendicular transverse slices, about half an inch thick, and these are allowed to lie in Müller's fluid two or three weeks longer, and may be kept in this indefinitely. They are then cut into pieces required to fit the microtome, and these are placed in ordinary methylated or absolute alcohol for three days, the spirit being changed each day. From this they are transferred to a mixture of equal parts pure alcohol and ether, in which

\* Zeitschr. f. Wiss. Mikr., v. (1888) pp. 338-40.

† Journ. of Anat. and Physiol., xxi. (1887) pp. 444-9.

they are allowed to lie for forty-eight hours. They are then transferred to a thin solution of celloidin in equal parts of ether and absolute alcohol. Collodion being cheaper than celloidin, and answering the same purpose, is preferable. In this solution the piece of tissue remains for at least three days, and is afterwards removed to a paper capsule filled with celloidin solution, and allowed to stand until a film forms on the surface. The mass is then consolidated by immersion for twenty-four hours in weak spirit, and the latter removed, in order that it may be sectioned in a freezing microtome, by immersion for 24 to 48 hours in Erlicki's fluid (bichromate of potash 5; copper sulphate 1; water 200).

The next step is to impregnate it with the last of the three following mixtures (C):—

A. Syrup (crystallized sugar 28.5 grm. to 31 ccm. water), 3 ccm.; mucilage (gum acacia, 57 grm. to 310 ccm. water), 5 ccm.; water, 9 ccm.

B. Solution A., 2 parts; syrup as above, 1 part.

C. Cupric sulphate, 1 grm.; potassii bichrom., 5 grm.; solution B, 200 ccm.

It is kept in an air-tight bottle filled with this mixture for at least three days at a temperature of 100° F. The microtome used by the author is a Rutherford's freezer of large size, and the knife an ordinary planing iron, such as is used by carpenters, and set in a wooden handle. Before placing the piece of tissue in the well it should be wiped, in order to remove the liquid in which it has been soaked. A quantity of mucilage, only sufficient to cause the piece to adhere, is then poured into the well, and in this the piece of tissue itself. The ice and salt in the box must be frequently renewed in order to keep the temperature as low as possible, and if the sections should adhere to the knife the mass is not sufficiently frozen or the knife has become too warm. To keep the planing iron cool it must be plunged in the freezing mixture after every four or five sections. When cut, the sections are removed at once to a dish filled with Erlicki's fluid, in order to dissolve any mucilage that may be adhering to it. No harm results if left herein for several days. The section is next transferred to a dish filled with weak spirit to remove the Erlicki's fluid. The spirit is to be changed once. A slide is now covered with a thin film of collodion, in which the section is placed, in the position it is intended to occupy, and when it has partially dried the upper surface is covered with collodion. When thus fixed to the slide it is transferred to absolute alcohol. If absolute or very strong alcohol be not used the collodion may strip off the slide. After it has lain for a few minutes in spirit it is ready for staining with Weigert's hæmatoxylin (hæmatoxylin 1, absolute alcohol 10, carbonate of lithia 1, distilled water 90 parts). The staining may be effected by leaving the preparation in a warm chamber at a body temperature for twelve hours or longer, but a quarter of an hour suffices to stain the fibres, even without the aid of the warm chamber, if the brain has been hardened long enough and the solution of hæmatoxylin of proper quality.

When the section and surrounding collodion are thoroughly blackened, the slide is washed in a running stream of tap water. The slide is then transferred to the ferridcyanide and borax decolorizer (borax 2, ferridcyanide of potassium 2½, water 100 parts), wherein it remains until all superfluous stain has been removed from the grey matter. When thoroughly decolorized, the slide, with the collodion still adhering, is transferred to running water for twenty-four hours, in order to thoroughly

remove all trace of the decolorizer, the incomplete removal of which causes the stain to fade sooner or later.

The edges of the collodion are next clipped off close to the preparation and the slide dehydrated in strong spirit. It is then immersed in oil of cloves, wherein it is almost instantaneously clarified. This done, the surface is washed with xylol, and finally mounted in a mixture of gum-dammar and gum mastic dissolved in xylol, and placed in a warm chamber for twenty-four hours.

#### Staining of Elastic Fibres with Chromic Acid and Safranin.\*—

Dr. L. Ferria, who has been examining various examples of safranin, 18 in all, found that these differed in colour, specific gravity, in their solubility in water and spirit, and in their behaviour with chromic acid.

When an aqueous solution of chromic acid is added to an aqueous solution of safranin a precipitate is thrown down. This precipitate may vary from an abundant red, almost black, to a scanty red or yellowish red, and it is the samples of the latter which are least satisfactory in staining the elastic fibres. These latter were certified by their makers to be the purer varieties, and the author notes also that those varieties which stained elastic tissues well were less suitable for staining nuclei or showing the nuclear mitosis.

The author also found that preparations which had been hardened in spirit were stained very well if the sections were left for about five hours in a watery solution of safranin (1 : 1000) at a temperature of about 37°, and then, having been washed, were placed in the safranin solution. If the specimen should be overstained so that the section is of a diffuse red colour, it should be treated for a short time with a very dilute alcoholic solution of caustic potash and then left for 24 hours in absolute alcohol. Only the nuclei of the tissue are then stained red, and contrast well with the blackness of the elastic fibres.

Clarifying in bergamot oil and mounting in dammar is said to aid the clearness of the picture.

**Congo-red as a Reagent for Cellulose.†**—Dr. E. Heinricher in examining the behaviour of Congo-red towards the thickenings in cell-walls which occur as reserve matter in the cotyledons of *Impatiens Balsamina* and other varieties of *Impatiens*, found that these thickenings were stained red. As another series of reactions negatived the cellulose nature of these thickenings, the author proceeded to examine the behaviour of this pigment towards the mucous element of plants. The general result was that Congo-red stains not only cellulose and amyloid matter, but also mucus of most of the plants examined.

Hence, the author concludes that Congo-red is not to be considered as a specific reagent for cellulose, and, if used for distinguishing it, great care must be taken to guard against errors.

**Simple and rapid Staining of the Tubercle Bacillus.‡**—Mr. H. P. Loomis recommends Ziehl's solution for staining the tubercle bacillus, and Fraenkel's methylen-blue solution as a contrast stain. This method has the merit of being simple and rapid and dispensing with the use of acids.

\* Zeitschr. f. Wiss. Mikr., v. (1888) pp. 341-3.

† Ibid., pp. 343-6.

‡ Medical Record, xxxiii. (1888) p. 631.

**Staining the Spirochæte of Relapsing Fever.\***—M. N. Nikiforow gives the following modification of his method of staining this micro-organism.

Instead of placing the drop of blood between two cover-glasses and then drawing them asunder, the author now takes a cover-glass between two fingers and touches the summit of a drop of blood with it, and then with the edge of a second cover-glass, held at an angle of  $45^\circ$  to the first, touches the blood, so that a thin layer becomes spread out on the first cover-glass. When dry the cover-glass is placed in a capsule of absolute alcohol, to which ether has been added. Herein the cover-glass remains from several hours to one day. When taken out, the preparations are stained with the ordinary watery anilin solution.

If the red corpuscles are not to be stained as well, the preparation must, before staining, be placed in 1 per cent. acetic acid.

**Pyridin in Histological Technique.†**—M. A. de Souza finds that, as pyridin coagulates albuminates with a neutral reaction, it can be used as a hardening agent. From the fact that it is miscible with oils and fats as with water, it possesses certain advantages where tissues are rich in such substances.

Hardening is effected in an incubator in about eight days, and with small animals in even a shorter time. The tissues are at once hardened, dehydrated, and cleared up, and can be easily sectioned and stained, as pyridin easily dissolves anilin dyes. The sections may be mounted in balsam, or, after four days' hardening, transferred to water without cockling. In the latter case they take up hæmatoxylin and picrocarmin very well.

The author obtained fair results by hardening skin in pyridin; he was less successful with liver, but the reagent seems suitable for pursuing the appearances in karyokinesis. The brain, however, gave the best results, the hardening being rapid and the cells of the grey matter staining deeply.

The author also employed this reagent for staining tubercle bacilli in sputum. The bacilli were rapidly stained without warming in the following way. A saturated solution of the dye (methyl-violet, fuchsin, or rubin) is made in pure pyridin. With this solution the preparation is moistened for 40–60 seconds; it is then decolorized in 30 per cent. nitric acid, and after being contrast-stained with vesuvin, cosin, or methylen-blue, also dissolved in pyridin, mounted in balsam. The method is more suitable for cover-glass preparations than for sections, although decent preparations can be obtained from the latter by soaking them in a dilute solution of ammonia.

If the advantages of pyridin are as stated by the author, there is no doubt it will be extensively employed.

**Modification of Garbini's Double Stain with Anilin-blue and Safranin.‡**—Dr. A. Garbini now uses carbonate of lithium as a decolorizer and his method is now modified and improved as follows:—Immerse the sections in 1 per cent. solution of anilin-blue for 2 to 4 minutes. Wash in distilled water; decolorize in a 1 per cent. solution of lithium carbonate. Then bring back the colour in a 0·5 per cent.

\* Wratsch, 1887, p. 183 (Russian). Cf. Zeitschr. f. Wiss. Mikr., v. (1888) pp. 107–8.

† Comptes Rendus Soc. Biol., iv. (1887) pp. 622–3.

‡ Zeitschr. f. Wiss. Mikr., v. (1888) p. 170–1.

hydrochloric acid. Wash carefully; immerse in safranin for 10 to 20 minutes, and if possible in the warm. Dehydrate in *methylated* spirit, and then decolorize in a mixture of oil of cloves (2 parts) and cedar oil 1 part. Then immerse in xylol until the right hue is attained. (See this Journal, 1886, p. 899.)

**Congo-red as a Reagent for Free Acid.\***—Herr C. Wurster has shown by experiment that Congo-red, when used for organic substances, is not a certain test of free acid. In the presence of ammonia it forms with this a compound which is not decomposed by organic acids at all and not readily by inorganic acids (carbonic, acetic, hydrochloric, sulphuric, &c.). The blue-violet colour which shows the presence of free acids, does not occur in the presence of ammonia, when organic acids are added, or on addition of inorganic acids when all the ammonia has been combined with the free organic acid.

Since in animal chemistry, ammonia in many cases can scarcely be excluded, the yellow-red coloration of Congo-red may remain persistent in spite of the presence of relatively large quantities of acid.

**Absorption of Anilin Pigments by living Animal Cells.†**—The results of the experiments made by Dr. G. Martinotti on the absorption of anilin dyes by animal cells differ in some particulars from those of Pfeffer, &c., who experimented in the same direction. It is found that living animal or vegetable cells, if made to live in a medium coloured with these pigments, are variously affected; that is, that certain of these dyes are more poisonous than others, a result which is reckoned by the more or less rapid staining of the nucleus; for when the nucleus becomes visible by being stained, this indicates that the cell is dying or dead. If, however, a quantity of pigment short of being poisonous be used, the protoplasm of the cell becomes stained. But according to the author, this quantity is, certainly for certain dyes such as methyl-violet, methyl-green, &c., infinitesimal, and he only found two, Bismarck-brown and methylen-blue, to give satisfactory results.

If tadpoles be placed in a very dilute solution of Bismarck-brown they take on a brownish-yellow colour in 24 hours, while the water has lost all its colour. And if the solution be renewed from day to day, they may finally be made to assume a yellowish-black hue characteristic of the dye. Again, if they be placed in pure water, all the absorbed dye may be gradually removed.

Microscopical examination showed that certain kinds of cells only possessed the power of selecting the pigment. These were the pigmented cells of the skin within which the dye collected in such a way as to completely conceal their shape. Other cells which were red stained were the branched connective tissue cells lying in the subcutaneous stratum. Certain other polygonal epithelioid cells were found to contain large well-stained granules in their protoplasm. In muscular fibre cells, in the walls of blood-vessels, its coloured granules were occasionally seen.

The action of methylen-blue was similar, but less active and less pronounced. While the animal was alive the author did not find that the axis-cylinder was stained, as Ehrlich did. With methylen-blue certain granules normally found in the red corpuscles assumed a deep blue colour.

With regard to the absorption of these dyes during cell-prolifera-

\* Centralbl. f. Physiol., 1887, p. 240.

† Zeitschr. f. Wiss. Mikr., v. (1888) pp. 305-13.

tion and its bearing on karyokinesis, the author found that it did not seem to have any direct relation to the nuclear mitosis. In order to fix the methylen-blue in the tissues an iodized solution of iodide of potash, or picrocarmine, or picrocarminate of ammonia, was used, the preparations being afterwards mounted in glycerin. This method was found to be inconvenient.

If Bismarck-brown be used, the tadpoles were immersed alive in a 0.2 per cent. solution of chromic acid. This fixed the tissues without affecting the Bismarck-brown. The tissues were then washed, and afterwards stained with safranin. In using spirit it is necessary to be cautious, as it rapidly absorbs the dye.

**Theory of Microscopical Staining.\***—Dr. H. Griesbach says that the more he considers the subject of microscopical staining the more he is convinced that it is based on chemical combinations taking place between the tissues and the pigments, both of which must, for various reasons, have very different chemical compositions at different times. This is easily obvious from certain examples, say, the composition of the infantile and adult brain. This difference in chemical composition is further augmented by the various reagents used for fixing the tissues, and also complicated by the reaction and composition of the dye itself. And so on.

**Starch Injection-mass.†**—Prof. S. H. Gage prepares a cold-flowing coarse injection-mass, the principle of which was first introduced by Ad. Pansch, from starch. This mass may be forced up nearly to the capillaries, rapidly hardens after injection, leaves the vessels flexible, and is suitable for permanent dry or alcoholic preparations.

Mass for ordinary injection : dry (laundry) starch, 100 ccm. ; water or  $2\frac{1}{2}$  per cent. aqueous solution of chloral hydrate, 100 ccm. ; 95 per cent. alcohol, 25 ccm. ; colour mixture, 25 ccm. When thoroughly mixed filter through two or three thicknesses of cambric. To prevent the starch from settling, the cloth should be tilted from side to side or the mass stirred during filtration.

The colour mixture : dry colour (e.g. Berlin blue), 100 ccm. ; glycerin, 100 ccm. ; 95 per cent. alcohol, 100 ccm. Mix well in a mortar and keep in stoppered bottle. If permanent preparations are not desired, anilin dyes may be used.

Special injection-mass for brains, &c. : corn starch, 100 ccm. ; 5 per cent. aqueous solution of chloral hydrate, 50 ccm. ; 95 per cent. alcohol, 75 ccm. ; colour mixture, 25 ccm. Either of the masses may be kept in large quantities in wide-mouthed bottles, but must be well stirred before using. If it be desired to inject very fine vessels, a preliminary injection should be made by using the stock mass diluted with an equal volume of water or of chloral solution. In any case it is advisable to make the injection as quickly as is possible.

A CHARD, C.—*Sur l'emploi de la teinture d'orcanette dans la technique histologique.*  
(On the employment of a tincture of orcanet in histological technique.)

*Arch. de Physiol.*, IX. (1887) pp. 164-8.

ERDÖS, J.—*Eine Methode zur Injection der Blutgefäße mit kaltflüssiger Masse.*  
(A method for the injection of the blood-vessels with a cold fluid mass.)

*Anat. Anzeig.*, III. (1888) p. 261.

KERTESZ, A.—*Die Anilinfarbstoffe. Eigenschaften, Anwendung, Reactionen.*  
(The Anilin stains. Properties, use, reactions.) Svo, Braunschweig, 1888.

\* *Zeitschr. f. Wiss. Mikr.*, v. (1888) pp. 314-19.

† *Amer. Mon. Micr. Journ.*, ix. (1888) pp. 195-6.

- KOWALEWSKY, N.—Ueber die Wirkung von Methylenblau auf die Säugethiere. (On the action of methyl-blue on mammals.) *Centralbl. Med. Wiss.*, 1888, p. 209.
- LETULLE.—Note sur un procédé de coloration stable de la matière amyloïde au moyen de l'éosine et de la potasse caustique. (Note on a process of stable staining of the amyloid matter by means of eosin and caustic potash.) *Bull. Soc. Anat. Paris*, II. (1888) p. 85.
- REDFERN, J. J.—The Pal-Exner Method of Staining Sections of the Central Nervous System. *Brit. Med. Journ.*, 1888, p. 642.

(5) Mounting, including Slides, Preservative Fluids, &c.

Mounting of specimens to be examined with homogeneous-immersion lenses.\*—Dr. A. Garbini adopts the following device for preventing any damage to the specimen from the resin or balsam being acted on by cedar oil or other solvents after the examination under homogeneous immersion or during the clearing of the cover-glass. The slide when mounted is baked for some hours at a temperature of 30° C., until the solvent of the resinous medium has been, as far as possible, evaporated. When cool the edge of the cover-glass is ringed round with a thinnish coating of gum. The material best suited for this purpose is sold under the name of Senegaline (Adrien Maurin, Paris). It may be made to take any colour if desired. By this device a cover-glass can be cleaned with xylol or benzol with the greatest ease.

Preparing Styrax Balsam.†—Dr. Th. Marsson, who recommends styrax for mounting microscopical specimens, prepares it in the following way:—The grey commercial styrax is shaken up every day several times for eight days with an equal quantity of chloroform until two layers have separated out, the lower one of which contains the styrax. The contents of the bottle are then filtered, the filter being moistened with chloroform, and the clear brown styrax solution evaporated to the consistence of a thin syrup. This syrupy mass is then placed in a bottle, of which it occupies not more than 1/6 of the space, and petroleum-ether is added little by little. A first a clear brown fluid is formed, but after a time a milky clouding shows that the styrax is beginning to separate out. The petroleum-ether may now be added in larger quantity in order to hasten the precipitation of the balsam. When all the balsam is thrown down the clear fluid is poured away, and then the styrax balsam is purified from all trace of chloroform or petroleum-ether by evaporation in a water-bath, after which the residue forms a thick, clear brown, stringy mass, and after exposure to the air dries quite hard and can be scratched with a needle. As the styrax balsam in this condition is too stiff for manipulation, it is thinned down with a solvent. The solvent used by the author is monobromnaphthalin, which has a higher refractive index than styrax, and diluted with this a perfectly clear solution is formed. It flows very easily under the cover-glass, but dries somewhat slowly.

Herstellung von flüssigem Kitt oder Gummi. (Preparation of fluid Cement or Gum.) [For every 500 cc. of the cement or gum dissolve 150 gr. of glue or gelatin, 12.5 gr. borax, and 6.25 gr. soda, in 750 cc. of water, and keep it for some hours below the boiling-point. Let it stand, decant and concentrate the fluid by evaporation. The solution is fluid at ordinary temperatures.]

*Chem. Ztg.*, 1888, p. 287; *Engl. Patent*, 1886, Nr. 13,168.

SMILEY, C. W.—Rinnbock's Slide of Arranged Diatoms, Chirodota wheels, Synapta plates, Synapta anchors, &c. *Amer. Mon. Micr. Journ.*, IX. (1888) pp. 199-200 (1 pl.).

\* *Zeitschr. f. Wiss. Mikr.*, v. (1888) pp. 171-2.

† *Ibid.*, pp. 346-50.

## (6) Miscellaneous.

**Garbini's Closed Water-bath.\***—Dr. A. Garbini uses a modification of the water-bath described in his 'Manuale per la tecnica del microscopio,' for the purpose of heating slides on which sections are to be stuck by Giesbrecht's or Mayer's methods.

The apparatus (fig. 184) consists of a rectangular box 20 cm. long, 15 cm. broad, and 4 cm. high, closed hermetically. From the middle of the bottom projects the copper bulb *a*, having a diameter of 8 cm. On one side is a small tube *b*, with a stop-cock. It connects with a wider tube *c*, into which may be fitted a cork bung, and a glass funnel, for the purpose of filling the box. Upon the top of the box, by means of four fluted pillars

FIG. 184.

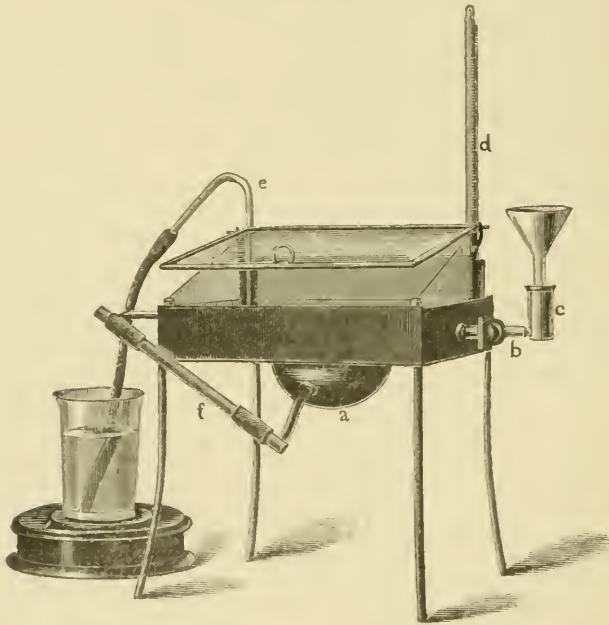

(the two front ones 0.5 cm. high, the two hind ones 4 cm. high) and three plates of glass fitting into the flutings a compartment is formed. This is closed above by a glass lid moving on hinges fixed to the posterior columns. From the figure it will be evident that this compartment is not quite closed when the lid is down, as there is a narrow aperture in front, and a wider one behind.

Behind the box are two glass tubes 3 cm. high, and with a diameter of 1.5 cm. Into one of these *d* fits a thermometer, and into the other a bent glass tube *e*, to carry off the steam.

Loss of water may be prevented by using, instead of the tube *e*, a

\* Zeitschr. f. Wiss. Mikr., v. (1888) pp. 166-8 (1 fig.).

glass tube 60 cm. high, with a diameter of 2 cm., in which the steam can condense, and flow back into the water-bath.

The quantity of water in the bath is shown by the gauge *f*. Two of the special advantages of this form of water-bath are the prevention of dust, and the current of air which carries off the various vapours so that the lid always remains bright, and the progress of the preparation may be watched.

**New Application of the Plasmolytic Method.\***—Herr H. de Vries suggests an application of the method of plasmolysis for the determination of the molecular weight of a given substance. The calculation of the isotonic coefficient of any compound soluble in water, by means of the law implied in De Vries's † method for the analysis of the force of turgidity, presupposes a knowledge of the molecular weight or equivalent of the substance in question. If, therefore, the isotonic coefficient is known, it follows from the law that the molecular weight can be ascertained. If two substances have the same isotonic coefficients, this must result from their solutions containing the same number of molecules in a given quantity of water. Application of this law was made in the case of raffinose, a sugar of considerable importance in the manufacture of beet-root sugar, with a much higher power of rotation than cane-sugar, and affecting the estimation of the latter in molasses.

Three formulæ have been proposed for raffinose, agreeing in their percentage composition, viz.  $C_{12}H_{22}O_{11} + 3H_2O$ ,  $C_{13}H_{22}O_{16} + 5H_2O$ , and  $C_{36}H_{64}O_{32} + 10H_2O$ . By the application of the proposed method, De Vries found the degree of concentration of raffinose isotonic with 0.1 molecule of cane-sugar to be 5.957 per cent. It follows that the molecular equivalent of raffinose must be approximately 595.7, which agrees very nearly with the second of the above formulæ.

**New Method for Demonstrating and Counting Bacteria and Fungi Spores in the air. †**—Dr. R. J. Petri's method consists in drawing air by means of an air-pump through a sand filter. The sand consists of particles 0.25–0.5 mm. and must be thoroughly heated. It is then made up into the shape of corks with wire gauze. Two of these filters, each 3 cm. long and 1.5–1.8 cm. broad, are inserted in a glass tube 8–9 cm. long. The two filters touch in the middle of the tube. The second filter serves to control the efficiency of the first, and should remain quite free from germs, all of which should have been picked up by the first. After the filters are fitted in, the ends of the tube are plugged with cotton-wool. During an experiment the plugs are removed and one end of the tube connected with an aspirator. The air should be removed at the rate of about 10 litres in 1 to 2 minutes. The rapidity of the air stream in the filter should never exceed 0.7 m. a second. The germ-laden sand is then strewn in flat double capsules about 9 cm. broad, and then liquid gelatin poured over it so as to form a layer, care being taken that the sand is uniformly distributed. As the colonies grow they can be counted and examined microscopically. For the purposes of examination the author has constructed a special enumerator, for information about which the original must be consulted. For the purposes for which it is intended, namely, the examination of

\* Bot. Ztg., xlv. (1888) pp. 393–7.

† See this Journal, 1885, p. 84.

‡ Zeitschr. f. Hygiene, iii. (1887) p. 1.

bacteria, &c., contained in air, both as to kind and number, the author maintains that his method gives better results than any other.

**Investigating the Effect of Remedies by the Microscope.\***—A new method of research, says Dr. Schneidemühl, has been proposed by Prof. Ellenberger and Dr. Baum, who by means of the Microscope study the effect of drugs on organs. The remedies or drugs were administered to animals, and these having been killed, their livers were sectioned in order to find out if the liver cells showed the regular dark granulation of rest, or if on account of increased activity, they showed only faint granulation at their periphery. The hepatic activity was found to be stimulated by pilocarpin, muscarin, aloes, salicylate of soda, benzoate of soda, while atropin, sulphate of magnesia, acetate of lead, hydrochlorate of ammonia, and calomel were inhibitory.

**'Annales de Micrographie.'**—This new monthly journal seems likely to prove a useful addition to microscopical literature. It is edited by Dr. Miquel, Chief of the Micrographical Service of the Municipal Observatory of Montsouris, Paris, assisted by Dr. Fabre-Domergue and M. E. de Freudenreich. It is intended to be devoted to Bacteriology, Proto-phyta, and Protozoa, and it will contain both original articles and abstracts of French and foreign papers.

BOWER, F. O.—**A Course of Practical Instruction in Botany. Part I.**

[Chap. I. deals with the making of preparations and the adjustment of the Microscope; Chap. II., practical exercises; Chap. III., Micro-chemical reactions, &c.] 2nd ed., 8vo, London, 1888.

JAKSCH, R. V.—**Manuel de diagnostic des maladies internes par les méthodes bactériologiques, chimiques et microscopiques.** Trad. par L. Moulé. (Manual of the diagnosis of internal diseases by bacteriological, chemical, and microscopical methods. Translated by L. Moulé.)

xix. and 355 pp., 108 figs., 8vo, Paris, 1888.

KELLICOTT, D. S.—**Presidential Address to the American Society of Microscopists, Columbus, O., 1888.**

[The nature of Protozoa and lessons of these simplest animals.]

*The Microscope*, VIII. (1888) pp. 289-309.

KÜHNE, H.—**Praktische Anleitung zum mikroskopischen Nachweis der Bakterien im thierischen Gewebe.** (Practical Guide to the microscopical demonstration of Bacteria in animal tissues.)

vi. and 44 pp., 8vo, Leipzig, 1888.

LATHAM, V. A.—**The Microscope and how to use it.**

[XV. Practical hints on histology. Special methods for examination of the spinal cord, brain, &c. *Continued.*]

*Journ. of Microscopy*, I. (1888) pp. 249-54.

MANTON, W. P.—**Rudiments of Practical Embryology. Continued.**

*The Microscope*, VIII. (1888) pp. 278-9.

*Scientific News*, II. (1888) pp. 512-3.

MIQUEL, P.—**Des procédés usités pour le dosage des bactéries atmosphériques.** (The methods used for determining the percentage of atmospheric bacteria.)

*Ann. Instit. Pasteur*, 1888, pp. 364-73.

WHELPLEY, H. M.—**Microscopical Examination of Drugs.**

*Amer. Mon. Micr. Journ.*, IX. (1888) pp. 203-5.

WOTHSCALL, E.—**Ueber die mikrochemischen Reactionen des Solanin.** (On the micro-chemical reactions of Solanin.)

*Zeitschr. f. Wiss. Mikr.*, V. (1888) pp. 19-38, 182-95.

\* *Zeitschr. f. Naturwiss.*, lxi. (1888) pp. 212-3.

PROCEEDINGS OF THE SOCIETY.

MEETING OF 10TH OCTOBER, 1888, AT KING'S COLLEGE, STRAND, W.C.  
DR. C. T. HUDSON, M.A., LL.D., PRESIDENT, IN THE CHAIR.

The Minutes of the meeting of 13th June last were read and confirmed, and were signed by the President.

The List of Donations (exclusive of exchanges and reprints) received since the last meeting was submitted, and the thanks of the Society were given to the donors.

	From
Sherborn, C. D., A Bibliography of the Foraminifera, Recent and Fossil, from 1565-1888. vi. and 152 pp. (8vo, London, 1888)	<i>The Author.</i>
Packard, A. S., Entomology for Beginners. xvi. and 367 pp., 273 figs. (8vo, New York, 1888) .. .. .	,,

The President said he had the melancholy duty to perform of announcing to the Society the death of one of their distinguished Honorary Fellows, which had taken place since they last met: they would know that he referred to the late Mr. Philip Henry Gosse. To himself the loss had been a very sad one, associated as he had been so intimately with that gentleman during their joint production of the work on the 'Rotifera.' He felt that it was unnecessary to say anything there as to his scientific attainments, or the value of the work which he had accomplished; his books and his drawings were familiar to microscopists wherever such were found. Those who had the advantage of his personal acquaintance could speak of him as a man who was absolutely free from the slightest spice of scientific jealousy, and who was always ready to place his stores of knowledge at the disposal of others. He was quite a stranger to him when they first met, and yet he placed the whole of his beautiful drawings in his hands with the freest permission to make full use of them. Fortunately, as they were aware, he was able to induce Mr. Gosse to join with him in the work of publication. He continued as vigorously at work up to the last as he had been at the time when he first met him, and a series of 60 to 70 large coloured drawings of new species which had recently been sent by his son, showed that up to within six months of his death, his hand and eye were as perfect as they were previously. It was proposed by the Council to fill up the vacancy thus occurring in their list of Honorary Fellows by the election of Prof. G. J. Allman, F.R.S., so well known by his work on the Polyzoa and Hydroids.

Lord Edward Churchill exhibited and described a form of photomicrographic apparatus, which had been made for him by Mr. Swift, and which he thought possessed some advantages. The objective was screwed into the end of the camera itself, and a movable stage with condenser, &c., worked in front of it, instead of working with these parts fitted to the body of a Microscope, with which he had found a difficulty both in focusing and in getting the image straight. A means was provided for chromatic adjustment, and for fine-adjustment, which could be easily

worked from the opposite end, an ordinary eye-piece being used for the purpose of focusing.

Mr. Pringle said that the camera upon the table was exceedingly similar to the one which he had first used for the purpose of photomicrography, resembling it in the most remarkable manner because of the objective being fixed to the body. The arrangement was one which he soon gave up, because he found it to be inconvenient, doubtful, and uncertain as to getting the object in the centre, and although the intention was to save trouble, he really found it gave a great deal more. Now he used a Microscope and light fixed upon a moving table, which turned upon a pivot, and had a stop by which it could be clamped if required; this was never out of centre to any great extent. He found the best plan for getting the object arranged was to use first a piece of ground glass and then plain glass with ruled lines.

Mr. J. Mayall, jun., said that in his opinion, when photography was to be used in connection with the Microscope, it was best to combine a really good Microscope with a substantial and well-made camera. It was only courting difficulty to build up such a photomicrographic apparatus as that under discussion, in which, however good the arrangements might be for the photography, those for the microscopy were wholly defective. No provision had been made to enable the worker to adjust the object at all conveniently, for the stage would ordinarily be out of reach when the image was being viewed. Microscopes were in general use to suit every class of work, and therefore it was sheer waste of ingenuity to construct photomicrographic apparatus with the intention of supplanting the use of a Microscope. If low-power work only were required, then a Microscope of moderate pretensions could be easily combined with a camera; but where high-power work was to be done, the highest class of Microscope must be employed, and special means were necessary to facilitate the centering of the image on the screen, and, above all, to enable the worker to control all the adjustments readily, and to assure himself, by direct inspection in the Microscope, that the image was such as he desired to photograph. These were the points sought to be embodied in the photomicrographic apparatus of Dr. Zeiss, Mr. Nelson, and others. The apparatus recently exhibited at the Society by Mr. C. L. Curties—in the designing of which he (Mr. Mayall) understood Mr. Nelson had assisted—was a praiseworthy attempt to construct a good and serviceable arrangement for combining a Microscope with a camera at a very moderate cost. The aim was distinctly practical, and based on a full knowledge of what had been done previously in that direction by other designers; but the apparatus designed by Lord Edward Churchill presented no points that he (Mr. Mayall) could commend, and was clearly a step in the wrong direction.

---

Mr. J. Mayall, jun., said that it would be remembered that some time ago Mr. E. H. Griffith, of the United States, sent a very pretty Microscope with a lamp attached to it; he had now sent another somewhat similar in appearance, but in which the chief novelty was the fine-adjustment. Mr. Ladd had devised one on somewhat the same general principle, that is, with the lever attached to the coarse-adjustment; but the action was here produced by a worm-wheel and a tangent screw that could be readily clamped to act on the coarse-adjustment. He thought,

however, this system was open to some objection, because the person using it would be apt to strain the mechanism if he inadvertently tried to move the coarse-adjustment when it was clamped to the fine-adjustment. The Microscope before them was very elegantly made, and he thought that Mr. Griffith was much to be congratulated upon its appearance (*supra*, p. 1022).

Mr. Crisp read to the meeting Mr. Griffith's description of the fine-adjustment, and showed how the base of the stand being unscrewed from the pillar and inverted upon a pin fixed in the case, formed an effective turntable.

The President thought the contrivance was very ingenious.

Mr. Crisp said they had had a great many criticisms in that room as to what constituted ingenuity in this respect, and there were some of the objectors who would consider it open to doubt whether a Microscope was not better if it could *not* be used as a turntable.

---

Mr. Crisp exhibited Cutter's Cam Microscope, with a tilting stage to act as a fine-adjustment, the tilting being effected by eccentric cams turned by a lever. Also, Fasoldt's "Patent" Microscope, by the use of which Mr. Fasoldt claimed that his test-plates could be resolved. It had an arrangement which prevented the body-tube running down on the object, an adapter for rapidly changing objectives, and an elaborated form of Beck's vertical illuminator.

Mr. Ingpen inquired if anything was said as to any peculiarity in the objectives?

Mr. Crisp said the objectives were not mentioned; the result was said to be due to the method of illumination, which was the vertical illuminator.

---

Mr. Crisp exhibited and described Zeiss's "micron" eye-piece micrometer, which obviates the necessity for constructing tables giving the value of an interval for each eye-piece and objective (*ante*, p. 797).

---

Mr. Rowland's reversible compressorium was exhibited and described by Mr. Crisp (*ante*, p. 803).

The President said this was practically the same as one which was made for him by Mr. Swift. This he gave up as useless, because, in consequence of the two surfaces of glass not being absolutely parallel to one another, the water was all carried off to one side. Unless the apparatus was made with a perfectly parallel motion it would be entirely useless.

Mr. C. Beck also remarked on its resemblance to Wenham's compressorium.

---

Mr. Crisp exhibited a form of safety stage (sent from America), which was fitted with two screws and nuts, by which the tension of the springs could be regulated as desired.

---

Mr. T. F. Smith exhibited some photomicrographs of portions of valves of *Pleurosigma formosum*, in illustration of what he imagined, from recent observations with high powers, to be the real structure. He had, he considered, discovered at least three layers, and thought there were possibly more. He had found the examination to be a matter of some

difficultly, because, if mounted in balsam, the finer details were obliterated, and if dry only such portions of the valve could be seen as adhered to the cover-glass. By means of drawings on the blackboard, he explained that the peculiarity consisted of a grating, each alternate hole of which threw an image in a different focal plane, giving the effect when seen by an achromatic condenser of a series of red beads with white spaces between them. In the photographs these beads came out square, and by deeper focusing they appeared blue, and the valve itself was seen to be somewhat hollow in section. Taken from that side, the valve showed two distinct layers of structure, and from the other side he found that there was a very delicate membrane and a series of lines with a number of fine rings stuck upon them; this structure was very indistinct owing to the interference of light in passing through the very fine membrane. On focusing deeper a grating was seen; but whether, in addition to these three layers, there was any other structure, he was at present unable to say. Referring to Dr. Carpenter's figures—which he reproduced on the board—he inferred that the appearance there shown must have been obtained by using oblique light: he had seen an appearance something like it, but could not say that this showed the real structure. He had examined other species of this genus, and had found at least a double structure in five other species—*angulatum*, *decorum*, *balticum*, and two species from Virginia. The photographs were all taken with central light, and with as large an aperture as could be used without spoiling the contrast.

Mr. Ingpen inquired if Mr. Smith had used any mounting media of a much higher refractive index, such as sulphide of arsenic, which would produce contrasts in opposite directions, and in which, if he got a happy fracture, he might see what would cause him to modify his opinions on some points.

Mr. Smith said he had not tried them: he was not a good hand at mounting, but he had tried them in Canada balsam without good results.

Mr. Ingpen said that Canada balsam would be useless; the diatoms should be mounted in something of a higher refractive index than themselves to get as strong a contrast as possible.

Mr. Karop said that one point which seemed to be overlooked was that diatoms in their fresh state were composed of silica in a colloid condition, and the treatment of this by acids in the course of preparation might account for a good deal of variation in the appearance of the structure.

Mr. Ingpen thought this was very probable, as it was impossible to get a perfect resolution of beadings or skeleton structure upon fresh specimens, the only exception being perhaps in the case of *Amphipleura*, which was so extremely delicate that, unless fresh specimens were procured, the structure would be found greatly destroyed. In the case of the stronger diatoms, it was necessary to submit them to acid or other treatment to remove surface or internal substances, which otherwise prevented what was supposed to be the complete skeleton from being seen.

Mr. J. Mayall, jun., said that one point had been touched upon which he thought needed a little clearing up. It had become somewhat fashionable for people to say that, in making their observations, they were most careful to exclude all oblique light, and that their improved ideas were due to the use of central light. Assuming that a condenser

were employed either within or without the focus, a circular diaphragm would cut off more or less of the oblique light: but the central portion used, unless reduced to a very small pencil, would still consist of sensibly oblique rays, because it was part of a solid cone of light. If strictly central parallel rays were to be employed, only a very small pencil would have to be utilised by means of a system of collimating diaphragms. He was not aware that any important results in microscopy had been obtained by the employment of such a pencil of light. A great deal too much was claimed on behalf of what was termed central light, regardless of the fact that some images could not even be glimpsed with the finest objectives in existence unless the illumination was limited to an intense beam of light of the highest obliquity the objective would transmit.

---

The President said they had received two exquisite photomicrographs of *Amphipleura pellucida* from Mr. E. M. Nelson, which would be found well worthy of inspection.

---

Mr. H. B. Brady's paper "On the Reproductive Condition of Orbitolites complanata, var. laciniata" (*ante*, p. 693) was communicated to the meeting by Prof. Bell, who said that the interest of the subject attached to the information given on a vexed point connected with these organisms. Two French naturalists had pointed out that there were what they called two forms, one of which had a small number of large chambers, and the other had a large number of small chambers. These they called form A and form B, and though there was nothing to show that there was any distinction of sex, it had been said that A and B were the males and females of the species. Mr. Brady came to the conclusion that the young forms were the result not of sexual intercourse of any kind, but of a process of gemmation.

---

Mr. Dowdeswell's letter was read, accompanying some photomicrographs of spermatozoa from the Triton:—

"I have the pleasure herewith to hand to the Society photographs of the spermatozoa of the Triton, showing with perfect distinctness the minute barb on the extremity of the head, the existence of which, I believe, has been doubted, but is here unmistakably evident. The photographs are admirable, and reflect great credit upon Mr. Andrew Pringle, of Cromwell House, Bexley Heath, Kent, who took them. If the barbs are not shown with absolute sharpness, I can testify that they are at least as distinct as in the preparation from which they are taken, which is five years old, and has become materially altered.

"I must beg to be allowed a few words of 'personal explanation,' and a reclamation, though not for myself. In my first mention of the existence of this process (*Quart. Journ. Micr. Sci.*, 1882, p. 73), I stated that it had been first observed and pointed out to me, in a preparation I had given him, by Mr. E. M. Nelson; but in the fuller notice, with drawing of it (*ib.* 1883, p. 336), which, being sent in late, was printed without a proof being sent to me for revision, I omitted to state this, and overlooked the omission till I saw the barb referred to as a discovery of my own. At the time, intending to publish some further observations on the subject, I omitted to correct this, and take this opportunity of

doing justice to Mr. Nelson, who deserves the more credit for his observation, as in the preparation he examined the point had escaped my own notice, which was directed to another feature—viz. the filament and membrane, both of which are clearly shown in one of the accompanying photographs. I hope the Society will be good enough to promulgate this note, as though it may be a matter of indifference to Mr. Nelson, it is not so to me—viz. that I should appear to allow to be attributed to me an observation first made by another.”

---

The following Instruments, Objects, &c., were exhibited:—

Lord Edward S. Churchill:—Photomicrographic Apparatus.

Mr. Crisp:—(1) Cutter's Cam Microscope; (2) Fasloldt's Patent Microscope; (3) Zeiss's "Micron" Eye-piece Micrometer; (4) Rowland's Reversible Compressorium; (5) Safety Stage with Adjusting Screws.

Mr. Dowdeswell:—Photomicrographs of Spermatozoa of Triton.

Mr. E. H. Griffith:—Griffith Club Microscope with new Fine-adjustment.

Mr. E. M. Nelson:—Photomicrographs of *Amphipleura pellucida*.

Mr. T. F. Smith:—Photomicrographs of *Pleurosigma formosum*.

---

New Fellow:—The following was elected an Ordinary Fellow:—  
C. H. Jolliffe.

---

MEETING OF 14TH NOVEMBER, 1888, AT KING'S COLLEGE, STRAND, W.C.  
THE REV. DR. DALLINGER, F.R.S., VICE-PRESIDENT, IN THE CHAIR.

The Minutes of the meeting of 10th October last were read and confirmed, and were signed by the Chairman.

The List of Donations (exclusive of exchanges and reprints) received since the last meeting was submitted, and the thanks of the Society given to the donors.

	From
Mawer, W., Primer of Micro-petrology, 68 pp., 26 figs. (8vo, London, 1888) .. .. .	The Author.
Slide of <i>Navicula venustissima</i> n. sp. .. .. .	Mr. F. Kitton.

---

Mr. Crisp exhibited a portable Microscope in a very heavy brass box which came from Vienna, the design being good, and closely resembling one brought out some years ago by Mr. Collins, but having a wood case. The disadvantage of a case made of such stout brass was apparent, seeing that it added so greatly to the weight of the whole that it could hardly be regarded as portable.

---

Mr. C. D. Ahrens' gigantic Microscope was exhibited. Mr. Mayall explained that Mr. Ahrens having invented a polarizer with a large field, had designed this Microscope for use in connection with it. The very large eye-piece gave a field of considerable diameter, but unfortunately it was only achromatized for the centre of the field, the outer portions showing colour in a very marked degree. The correction was also very imperfect for flatness of field, so that if a slide of fine writing were examined it could only be read across the centre of the field, the outer

portions being entirely out of focus; or if the outer portion was focused the centre was entirely indistinct. Of course the advantages of a large field were obvious in a Microscope of that kind, but with only a partial achromatism the eye-piece was neither one thing nor another.

---

Mr. Ahrens' erecting Microscope for dissecting was also exhibited, the chief improvement consisting of the incurved form of the hand-rests.

Mr. Michael did not think there was anything particularly new about this: practically he had been using the same thing for some time past.

---

Dr. Bate exhibited and described a small case for holding a number of cover-glasses, intended especially for the use of persons engaged in bacteriological studies. The interior was arranged as a series of racks to take  $\frac{3}{4}$  in. covers, each one sufficiently separated from the others to prevent them from touching, and every tenth groove being indicated by an engraved number to facilitate reference. Being made entirely of metal, screwed together and without solder, it could be readily taken to pieces for sterilization by heat or for cleaning. There were places for forceps, and a card for memoranda was fitted inside the cover. He thought it would be found extremely useful by medical men, who could, in the course of their professional visits, transfer small portions of sputa or pus to glass covers and carry them home in this way for examination.

A Fellow asked if any provision had been made for preventing the mixing of various germs, as he thought that in the event of the covers becoming dry, portions of what had been placed upon them might get detached; also it seemed likely that the places where the glasses fitted in might get coated with the matter, and cause it to get mixed.

Dr. Bate said he had made no provision against the possibility of the germs falling about, but there would be no difficulty whatever as to cleaning. The box might, he thought, be found useful in drying sputum, &c., in a sulphuric acid chamber.

---

Mr. Crisp called attention to a new foreign publication, 'Annales de Micrographie,' an extract from the prospectus of which was read to the meeting (*supra*, p. 1062).

---

Prof. Bell read a paper "On the Large Size of the Spicules of *Acis orientalis*" (*supra*, p. 921).

---

Mr. William West's paper "On a List of Desmids from Massachusetts" (*post*) was explained by Mr. Bennett. Mr. Bennett said he had looked over the paper, and was somewhat doubtful if one of the species described as new was really a *Xanthidium*. The paper would be a useful addition to their knowledge of the Desmids, and was interesting as showing what a large number of them were cosmopolitan.

---

Mr. Crisp read a paper by Prof. Govi, the object of which was to show that Galileo invented the Compound Microscope in 1610.

Mr. J. Mayall, jun., said it would, of course, be very difficult to discuss so many points as those mentioned by Prof. Govi off-hand, because his paper was evidently the result of very considerable research and would require careful consideration. Many of his quotations were, of course, well known to those who had made investigations into the history of the Microscope, but there was one which seemed of rather more importance, in which Galileo excused himself in 1620 for not sending the instrument on account of its not being completed at that time. Another point was with regard to its being called a compound Microscope, when it had a convex lens at one end and a concave lens at the other. The modern definition of a compound Microscope was that the image projected by the objective should be examined by an eye-lens. In the so-called Brücke lens the object itself was seen, and not the aerial image. He thought, therefore, that Prof. Govi should more strictly define what he meant by a Compound Microscope. As to Galileo making lenses with the magnifying power assigned, he could only say that he was not impressed with the idea that any such power as 36 was obtained with the instruments in the Museum at Florence. He hoped to be able to submit to Prof. Govi some considerations as to the possibility of getting 36 diameters with such an arrangement, and if it was as he imagined, it might lead the Professor to modify his opinions.

---

The Chairman announced that the Society's next *Conversazione* would be held on Wednesday, the 28th inst.

---

The following Instruments, Objects, &c., were exhibited:—

Mr. Ahrens:—Erecting Dissecting Microscope.

Dr. Bate:—Case for Cover-glasses.

Mr. Crisp:—(1) Portable Microscope in heavy brass box; (2) Ahrens' large Microscope for polarizer, with large field.

Mr. F. Kitton;—*Navicula venustissima* n. sp.

---

New Fellows:—The following were elected *Ordinary* Fellows:—Messrs. Alfred D. Bell, Frank Inskipp, C. A. Macallum, M.A., R. Macer, E. W. A. A. Mayhew, Charles Rousselet, and George H. Wright; and Prof. George James Allman, F.R.S., was elected an Honorary Fellow.

---

## INDEX.

## A.

- Abbe Camera Lucida, Large form of, 113.  
 ————, Screen for, 809.
- Abbott, A. C., Improvement in the method of preparing Blood-serum for use in Bacteriology, 142.
- , H. C. de S., Plant Analysis as an Applied Science, 89.
- Absorption of Water by Gastropoda, 563.
- Acanthus spinosus, Tannin in, 72.
- Acarida on Trees, 34.
- Acetabularia, Incrustation of the Cell-wall of, 463.
- Achard, C., Employment of a tincture of orcanet in histological technique, 1056.
- Acid, Free, Congo-red as a Reagent for, 1055.
- Logwood Stain, 517.
- Acids, Formation of Organic, in the growing parts of Plants, 247.
- Acineta, New Species of, 438.
- Acinetoides, 974.
- Acis orientalis, Note on the Large Size of the Spicules of, 921.
- Actinïa, Larval, parasitic on Hydro-medusæ, 965.
- of Coasts of France, 593.
- Actiniaria, 'Challenger,' Supplementary Report on, 965.
- Actinomyces, On Staining, 849.
- Acton, E. H., Formation of Sugars in the Septal Glands of Narcissus, 759.
- Adan, H. P., The Invisible World revealed, 523.
- Address, The President's 177.
- Æcidium, Sexual Organs in, 782.
- Aerial Stems, 451.
- Aerophytic Species of Ulotrichaceæ, 1002.
- Africa, Fresh-water Crabs of, 415.
- Agar and Gelatin, Preparation of Nutrient, 825.
- Agar-agar for Cultivation, 656, 1036.
- Agaricinæ, Classification of, 467.
- Agaricus procerus, Abnormal Fructification of, 269.
- Ahrens' (C. D.) New Erecting Microscope, 1020.
- Aievioli, E., Phenol in Microscopical Technique, 847.
- 1888.
- Air, Improved method for the Bacteriological Examination of, 854.
- Air-canals of the Root, Diaphragms in, 447.
- Albumen in the Cell-wall, 69, 982
- of Cycas, Rooting of, 988.
- of Plovers' Eggs as Nutrient Medium for Micro-organisms, 1037.
- Albumin, Active, in the Cell-sap, 246.
- , ——, Separation of Silver by, 244.
- Albuminoid Constituents of White of Egg, 551.
- Albuminoids, New Reagent for, 165.
- , Synthesis of, 455.
- Albuminous reaction of Cell-wall, 602.
- Alcoholic Alum-carminé Stain, 517.
- Aleyonaria, Classification of, 237.
- , Norse, 239.
- Aleyonella, Spermatogenesis in, 566.
- Aleyonidium gelatinosum, Reproductive Organs of, 208.
- Aleyonids, Nervous Tracts in, 61.
- Aleurone-grains, Development of, in the Lupin, 982.
- - ——, Formation of, 443.
- - —— in the Seed of Myristica surinamensis, 72.
- Alge, Application of Lactic Acid to the Examination of, 666.
- , Isolating Lower, 511.
- , See Contents, xxviii.
- Alimentary Canal in Metamorphosis, 943.
- Alkali-albuminate as a Nutrient Medium, 825.
- Alkaline Egg-albumen as a Medium for Bacteria Cultivation, 503.
- Alkaloid and Sugar in Cyclamen, 759.
- Allen, T. F., American Characæ, 461.
- , Collecting and Preparing Characæ, 828.
- , New Species of Characæ, 90.
- Alligator lucius, Eggs of, 925.
- Allurus tetradrus, Anatomy of, 421.
- Almonds, Localization of Emulsin in, 247.
- Alpheus, Abbreviated Metamorphosis of, 414.
- , Development of, 577.
- Alpine Flowers, Size and Colour of, 452.
- Plants, Pollination of, 454.
- Alstroëmeria, Explosive Fruits of, 255.

- Alternation of Generations in Green Plants, 459.  
 Altmann, R., Demonstrating Cell-granules, 146.  
 Alum-carmine Stain, Alcoholic, 517.  
 Anans, —, Aquatic Locomotion, 19.  
 Ambrohn, H., Pleochromism of Coloured Cell-walls, 602.  
 Ambrosiaceæ and Seneceioideæ, Comparative Anatomy of, 449.  
 America, North, Two new Aquatic Worms from, 582.  
 American and Foreign Microscopes, 797.  
 — Characeæ, 461.  
 — Fresh Waters, Notices of new Infusoria Flagellata from, 698.  
 — Microscopes, 652.  
 — —, A Complaint, 285, 482.  
 — Postal Microscopical Club, 304, 654.  
 — Society of Microscopists. Columbus, Ohio, Meeting (1888), 503.  
 — Tarantula, Age and Habits of, 215.  
 Amœbocytes of Crustacea, 949.  
 Amœbid Corpuscles in the Star-fish, Emigration of, 431.  
 Amphibia, Preparing Ova of, 146.  
 Amphibians, Fate of the Blastopore in, 189.  
 —, Gastrula of, 549.  
 Amphioxus, Nervous System of, 390, 929.  
 Amphipleura pellucida, Curious Interference Phenomena with, 302, 1035.  
 Amphipod, New Commensal, 416.  
 Amphipoda, Sexual Dimorphism in, 949.  
 Amphiuira squamata, Development of Apical Plates in, 58.  
 Ampullaria, Anatomy and Affinities of, 204.  
 Amygdalæ, Disease attacking, 781.  
 Anaerobic Microbes, Cultivation of, 1038.  
 — Micro-organisms, Cultivation of, 824.  
 — — — — —, New Method for Cultivating, 1037.  
 Ancestry of Man, 193.  
 Anderson, H. H., New Parasitic Infusoria, 436.  
 André, G., and Berthelot, —, Phosphorus and Phosphoric Acid in Plants, 760.  
 Andreea and Sphagnum, Sporogonium of, 91, 1000.  
 Anemone apennina, Germination of, 613.  
 Angiotelella, G., and C. Cianci, Structure of Red Blood-corpuscles, 928.  
 Anguillidæ of the Onion, 585.  
 Anilin Pigments, Absorption of, by living Animal Cells, 1055.  
 — Stains, 1056.  
 Anilin-blue and Safranin, Modification of Garbini's Double Stain with, 1054.  
 — -oil Safranin Solution, 676.  
 Animals and Vegetables, Distinction between, 257.  
 Ankylostomum duodenale, 739.  
 Annales de Micrographie, 1060.  
 Annelida, Preparing and Staining, 662.  
 —. See Contents, xiv.  
 Anolis, Embryology of, 387.  
 Antedon rosacea, Development of, 232.  
 Antennary Sensory Organs of Insects, 723.  
 Antherozooids of Cheilanthes hirta, 999.  
 Antherozooids of Hepatiæ, 461.  
 Anthozoa, New Type of, 745.  
 Ants and Plants in the Tropics, Relationship between, 772.  
 —, Senses of, 571.  
 —, So-called Digestive Stomach, 570.  
 Aorta of Bombyx mori, 212.  
 Apáthy, L., Histology of Najadæ, 205.  
 —, Preparing Long Series of Sections with Celloidin, 670.  
 —, Further Notes on Celloidin Technique, 836.  
 —, S., External Morphology of Hirudinea, 950.  
 Aphides, 727.  
 —, Development of, 573.  
 Apical Growth of Leaf, Duration of, 455.  
 — meristem of the Roots of Pontederiaceæ, 248.  
 — Plates in Amphiuira squamata, Development of, 58.  
 Aplysia, Nervous System of, 20.  
 —, Spermatogenesis in, 397.  
 Apochromatic Objectives, 285, 287.  
 Apogony and Viviparous Plants, 768.  
 — in Notochlæna, 999.  
 Apples, Potato, and Water for cultivation purposes, Sterilization of, 310.  
 Apeudes and the Tanaidæ, 416.  
 Aquarium Microscope, Collins's, 103.  
 Aquatic Locomotion, 19.  
 Araceæ, Roots of, 607.  
 Arachnactis and Cerianthus, 743.  
 Arachnida. See Contents, xiii.  
 Arachnoidiseus as a New Test for High-power Objectives, 815.  
 Aralia, Thickening of the Cell-walls in the Leaf-stalk of, 70.  
 Araliaceæ and Umbelliferæ, Secreting Canals contained in the Phloëm, 605.  
 Araucaria, Secretary Canals of, 986.  
 Arcangeli, G., Flowering of Euryale ferox, 83.  
 —, Influence of Light on the Growth of Leaves, 614.  
 —, Saccharomyces minor, 633.  
 Arceuthobium, 991.  
 Arloing, S., Modification in a Bacteriological Analyser, 311.  
 —, Presence of a Phlogogenous matter in the Cultures of certain Microbes, 634.  
 Armillaria mellea, Rhizomorpha subcorticis of, 97.  
 Arnold, J., Cell-division, 712.  
 —, Division and Metamorphosis of Wandering Cells, 393.  
 Arnstein, C., Staining Nerve-endings with Methylene-blue, 515.  
 Arsonval, D', New Incandescient Gas-light, 1033.  
 Arthropoda. See Contents, xii.

- Arthur's (—) Report on Minnesota, 89.  
 Artichoke, Jerusalem, Germination of the  
 Tuber of, 613.  
 Articulata, Nerve-centres and Sensory  
 Organs of, 403.  
 Ascaris, Fertilization of, 583, 736.  
 —, Intestinal Epithelium of, 583.  
 —, Larval Stage of Species of, 45.  
 —, lumbricoides and *Tænia elliptica*,  
 Life-history of, 426.  
 Ascaris megaloccephala, Abnormal Ova of,  
 953.  
 — —, Boveri's Method of Preparing  
 the Eggs of, 664.  
 — —, Fertilization and Segmentation  
 in, 43, 423.  
 — —, Preparation of, 148.  
 — —, Preparing Ova of, 508.  
 — —, Zacharias' Method of Preparing  
 the Eggs of, 663.  
 — Ova, Maturation and Division of, 42.  
 —, Polar Bodies in, 43, 425.  
 Asci, Formation of, in *Physalospora Bid-*  
*wellii*, 629.  
 — of *Penicillium crustaceum*, 271.  
 Asclepiadæ, Insect relations of, 82.  
 Ascomycetes, Cultivation of Lichen-form-  
 ing, without Algæ, 466, 829.  
 —, Oleina and Podocapsa, New Genera  
 of, 271.  
 —, "Spermatia" of, 1006.  
 Ascophorous form of *Penicillium candi-*  
*dum*, 1008.  
 Ascospora Beijerinckii, 1007.  
 Asellicola digitata, 973.  
 Asellus, Structure of, 948.  
 Askenasy, E., Development of *Pediastrum*,  
 624.  
 Aspergillus, New, 1008.  
 Aspidium Filix-mas, Aspidol from, 619.  
 Aspidogaster conchicola, 954.  
 Aspidol from *Aspidium Filix-mas*, 619.  
 Asplanchnidæ, 740.  
 Assimilation and Expiration of Plants,  
 768.  
 — and Respiration of Plants, 258.  
 — Daily, of Carbohydrates, 994.  
 — in Plants destitute of Chlorophyll,  
 455.  
 Asterias, Preparation of Embryos of, 1045.  
 Atmospheric Movement, Influence of, on  
 Transpiration, 259.  
 Attachment-organ of Algæ, 461.  
 Auditory Hairs, So-called, 411.  
 Auer incandescent gas-burner, 495.  
 Aulacodiscus, A Monograph of the Genus,  
 335, 337.  
 —, Varieties of, 627.  
 Auliscus, Ehrb., A Revision of, and of some  
 allied Genera, 861.  
 Aurantiacæ, Anatomy and Diseases of,  
 453.  
 Aurivillius, C. W. S., Acarida on Trees, 34.  
 Australian Earthworms, New, 420.  
 Auxanograph, Hilgendorf's, 646.  
 Auxospores, Formation of, in Diatoms, 268.  
 Avetta, C., Anomalies in the Structure of  
 the Roots of Dicotyledons, 606.  
 Axis, Embryonic, 923.  
 — of Frog Ovum, 15.  
 — of the Inflorescence, 79.  
 Axis-cylinder and Nerve-cells, 556.  
 —, Segmentation in, 392.  
 Axolotl, Development of, 707.
- B.
- B., J. E., Review of Tripp's 'British  
 Mosses,' 1036.  
 Babes, V., Anilin-oil Safranin Solution,  
 676.  
 — Hot Stage, 800.  
 —, Methods for Pathological Investiga-  
 tions, 154.  
 — Modified Cultivation Vessel, 828.  
 Babuchin's (A.) Microscope, 637, 794.  
 Baccarini, P., Sphærocrystals, 603.  
 Bacilli of Xerosis conjunctivæ, and Spore-  
 formation in, 1016.  
 —, Phosphorescent, Photographing by  
 means of their own light, 813.  
 —, Staining Lepra and Tubercle, 157,  
 846.  
 Bacillus cœruleus, 472.  
 —, Dissemination of, by Flies, ( 35.  
 — living at a temperature exceeding  
 70° C., 1013.  
 — muralis, 276, 786.  
 —, New Chromogenic, 472.  
 — of Glanders, Spore-formation in, 473.  
 —, Phosphorescent, 277.  
 —, Scheuren's Cancer, 472, 785.  
 —, Supposed Spores of the Typhoid,  
 1016.  
 —, Tubercle, Simple and Rapid Stain-  
 ing of, 1053.  
 —, — Stain, Specificness of, 157.  
 — Tuberculosis, Cultivation of, on  
 Potato, 1038.  
 —, "Typhus," Cultivation of, in  
 coloured nutrient media, 1039.  
 Bacteria and Fungi Spores, Demonstrating  
 and Counting of, in the Air, 1059.  
 — and Root-tubers, 82.  
 —, Cellar, 1014.  
 —, &c., Chemotactic movements of, 770.  
 — Cultivation, Alkaline Egg-albumen  
 as a Medium for, 503.  
 —, Endospores, 1014.  
 — for laboratory purposes, Methods of  
 examination of, 686.  
 — in animal tissues, On a combined  
 universal process for demonstrating, 315.  
 — in Hallstones, 277.  
 —, Iron-, 786.  
 —, Lectures on, 102.  
 —, New Method of cultivating in  
 Coloured Media for Diagnostic Pur-  
 poses, 1039.  
 —, Phosphorescent, from Sea-water, 101.

- Bacteria, Spore-formation in, 787.  
 —, Symbiosis of, with *Glœoeapsa polydermatica*, 634.  
 —, Technique of, 151.  
 Bacteria-like Bodies in Tissues and Ova, 31.  
 Bacterial Cultures, Method of preparing Potatoes for, 143.  
 — Growth at 0° C., 1014.  
 — — between 50° and 70° C., 824.  
 — Increase, Method of Calculating the Rapidity of, 682.  
 Bacterio-purpurin, 473.  
 Bacteriological Analyser, Modification in, 311.  
 — Examination of Air, Improved Method for, 854.  
 Bacteriology, Improvement in the Method of Preparing Blood-serum for use in, 142.  
 Bacterium *Laminariæ*, Life-history and Morphological Variations of, 275.  
 —, New Marine, 789.  
 Badhamia and Brefeldia, Plasmodium of, 783.  
 Bahamas, New *Pennatula* from, 593.  
 Bailey, G., H. W. Burrows, and C. D. Sherborn, The Foraminifera of the Red Chalk, 383.  
 Baillon, H., Ovules of Grasses, 611.  
 —, — of *Plantago*, 452.  
 Baker, J. G., *Enterosora*, 262.  
 Balanoglossus *Mereshkovskii*, 588.  
 Baldini, T. A., Emergences on the Roots of *Podocarpus*, 252.  
 Balfour, J. B., Replum in *Crucifera*, 611.  
 Baland, —, Development of Wheat, 769.  
 Balsam Bottle, Doty's, 163.  
 Baltimore Microscopical Society, 304.  
 Baltzar, G., and E. Zimmermann, Microtome with fixed knife and automatic movement of the object, 842, 1049.  
 Bambeke, C. Van, Artificial Deformations of the Nucleus, 196.  
 Bamberg's Spherometer Microscope, 280.  
 Baránski, A., On Staining Actinomyces, 849.  
 Barbaglia, G. A., Chemical Substances contained in the Box, 72.  
 Barbe, —, and P. A. Dangeard, Arrangement of the Fibro-vascular Bundles in *Pinguicula*, 74.  
 Baregine and Glairine, Physiological Experiments on Organisms of, 1019.  
 Barley, Saccharomyces *ellipsoideus* and its Use in the Preparation of Wine from, 785.  
 Barrois, J., Development of *Comatula*, 960.  
 —, T., Sexual Dimorphism in Amphipoda, 949.  
 Bartet, —, and Vuillemin, —, "Rouge" of the Scotch Fir, 781.  
 Bartoschewitsch, S., Fire-proof Cotton-wood Plug for Test-tubes, 1040.  
 Eary's (A. De) Lectures on Bacteria, 102.  
 —, Obituary Notice, 140.  
 Basal Spot on Palps of Butterflies, 943.  
 Basidiomycetes, 1006.  
 —, Classification of, 778.  
 —, Heterobasidial, 1006.  
 Bastin-Bullock Microscope, 285.  
 Bat, Attachment of the Blastocyst to the Uterine Wall in, 387.  
 Bataillon, —, and F. Houssay, Development of the Axolotl, 707.  
 Bate, C. S., 'Challenger' *Crustacea Macrura*, 948.  
 —, G. P., Case for Cover-glasses, 1067.  
 Bateson, A., Effect of Cross-fertilization on Inconspicuous Flowers, 612.  
 —, and F. Darwin, Method of Studying Geotropism, 770.  
 Bather, F. A., Growth of Cephalopod Shells, 200.  
 —, Shell-growth in Cephalopoda, 397, 559.  
 Batrachospermum, *Chantransia*, and *Lemanea*, 464.  
 Baum, —, Investigating the Effect of Remedies by the Microscope, 1060.  
 Baumgarten's (P.) Method of Triple-staining, 676.  
 — Pathological Mycology, 791.  
 — Scherren's Cancer Bacillus, 472.  
 — Spore-formation in the Bacillus of Glanders, 473.  
 Bausch, E., Society Screw, 486.  
 Bausch and Lomb Optical Co.'s Petrographical Microscope, 279.  
 — — "Watchmaker Glass," 795.  
 Bdellostoma, Ova of, 192.  
 Beaumont's (C. R.) Reservoir Life-slide, 804.  
 Beauregard, H., and V. Galippe, Practical Guide to Microscopy, &c., 323.  
 Beauvige, —, Bracts of *Crucifera*, 609.  
 Beck, R. and J., Adjusting an Objective for the Thickness of the Cover-glass, 497.  
 Beck's Microsyringe, 849.  
 Beddard, F. E., Anatomy of *Allurus tetradrus*, 421.  
 —, — of *Perichæta*, 422.  
 —, Eyes of *Cymothoidæ*, 730.  
 —, Mucous Gland of *Urochæta*, 422.  
 —, Nephridia of Earthworms, 421.  
 —, New Gregarine, 976.  
 —, Reproductive Organs of *Moniligaster*, 221.  
 —, — — of *Phreoryctes*, 579.  
 —, So-called Prostate Glands of *Oligochæta*, 221.  
 —, Structural Characters of Earthworms, 420.  
 Beecher, C. E., Preparing Radulæ of small species of *Gastropoda*, 507.  
 Beeke, F., Measuring Corrosion Surfaces in Iron Pyrites, 803.  
 Beer-ferment, Organic nourishment of, 785.  
 Bees, Nutrient Food-Material of, 942.

- Bell, F. J., Note on the Large Size of the Spicules of *Acis orientalis*, 921.
- , Remarkable Ophiurid from Brazil, 591.
- Bellucci, G., Formation of Starch in the Chlorophyll-grains, 71, 983.
- Bellonci, G., Polar Globule of Mammalian Ovum, 186.
- Belzung, E., Starch- and Chlorophyll-grains, 70.
- Benda, C., A new hardening method especially for the central nervous system, 834.
- Benda's Modified Copper-hæmatoxylin, 158.
- Beneden, E. v., Attachment of the Blastocyst to the Uterine Wall in the Bat, 387.
- , Classification of Tunicata, 206.
- , Fertilization and Segmentation in *Ascaris megaloccephala*, 423.
- , Preparing Ova of *Ascaris megaloccephala*, 508.
- Benham, W. B., New Earthworm, 222.
- Bennett, A. W., Fresh-water Algae (including Chlorophyllous Protohyta) of the English Lake District. II. With descriptions of a new genus and five new species, 1, 171.
- , Rare Alga at Kew, 687.
- Benze, W., Leaves of Polyodiaceæ, 619.
- Berard, E., and G. Corin, Albuminoid Constituents of White of Egg, 551.
- Bergendal, D., Male Appendages on Female Crabs, 730.
- Berggren, S., Apogamy in *Notochlæna*, 999.
- Bergh, R. S., Excretory Organs of *Criodilus*, 953.
- Beringer, G. M., Photoxylin for Imbedding, 834.
- Berlese, A. N., Clathrospora and Pyrenopora, 631.
- , New Genus *Peltosphæria*, 630.
- , Pleospora, 469.
- Bernard, F., Anatomy of *Valvata piscinalis*, 719.
- , Mantle of Gastropods and Dependent Organs, 399.
- Bertelli, D., Salivary Glands of Leech, 38.
- Berthelot, —, and G. André, Phosphorus and Phosphoric Acid in Plants, 760.
- Berthold, G., Nuclear and Cell-division, 440.
- Bertkau, P., Scent Organs of German Lepidoptera, 406.
- Bertrand's (E.) Refractometer, 291, 649.
- Bessey, C. E., Overlooked Function of many Fruits, 992.
- Bevan, E. J., Indian Fibres, 495.
- Beyerinck, M. W., *Cecidium* of *Nematus Caprææ*, 458.
- Bicuba, Germination of, 613.
- Biddulphia from Fiji, New Species of, 466.
- Bidwell, W. D., The Microscope in Medicine, 654.
- Biedermann, W., Innervation of Crabs' Claws, 947.
- Biehinger, J., Inversion of the Germinal Layers in the Shrew, 706.
- Bigelow, R. P., Frond of *Champia parvula*, 623.
- Bigeneric Orchid Hybrids, 257.
- Bilharzia, 588.
- Billet, A., Life-history and Morphological Variations of *Bacterium Laminariæ*, 275.
- , New Marine Bacterium, 789.
- Biological Studies of Fungi, 628.
- Biondi, D., New Method for Investigation of Blood, 313, 659.
- Birch and Hornbeam, Spring-sap in, 445.
- Birch, H., On the Cultivation of Schizomycetes in coloured Media, 145.
- Birch-Hirschfeld, —, Cultivation of Schizomycetes in Coloured Nutritive Media, 823.
- of the "Typhus" Bacillus in coloured nutrient media, 1039.
- Bird's Feather, Methods of studying typical, 314.
- Birds, Distribution by, 930.
- Bizzozero, G., and G. Vassale, Staining Mitoses, 674.
- Blackburn, W., Diffraction Spectra, 652.
- Blake, J. F., and F. A. Bather, Shell-growth in Cephalopoda, 559.
- Blake, J. H., Prickle-pores of *Victoria regia*, 81.
- Blanc, H., New Foraminifera, 598.
- Blanchard, R., *Monas Dunali*, 973.
- , Phosphorescence in Myriopoda, 945.
- , Striated Muscles in Mollusca, 402.
- , Structure of Muscles of Lamellibranchiata, 935.
- Blaps, Odoriferous Glands of, 943.
- , Intermediary host of *Echinorhynchus*, parasitic in Man, 739.
- Blastocyst, Attachment of, to the Uterine Wall in the Bat, 387.
- Blastopore, Fate of, in *Rana temporaria*, 925.
- in Amphibians, Fate of, 189.
- Blatta germanica*, Development of Endoderm of, 406.
- Blochmann, F., and C. Hilger, *Gonaetia proliferata*, 593.
- , J., Bacteria-like Bodies in Tissues and Ova, 31.
- Blood, Colouring matter of, as a means of distinguishing between the gas exchange of plants in light and darkness, 322.
- , decomposing, *Spirillum concentricum*, a new species from, 278.
- , Hæmoglobin Crystals of Rodents, 198.
- in Teleostei, Origin of, 192.

- Blood, New Method for Investigation of, 313, 659.  
 — of Invertebrata, 557.  
 — of Spiders, 946.  
 Blood-corpuscles, Artificial Serum for Computation of, 162.  
 — — —, Double-staining of Nucleated, 673, 842.  
 — — —, Improved Method for Enumerating, 854.  
 — — —, Methods of Examining, 1040.  
 — — —, Preserving, for Microscopical Examination, 1041.  
 — — —, Red, Development of, 395.  
 — — —, Structure of, 198, 928.  
 — — —-serum for use in Bacteriology, Improvement in method of preparing, 142.  
 — — —-stains, Medico-legal Identification of, 520.  
 — — —-vascular System of the Chick, Development of, 187.  
 — — —-vessels, Injection of, with a cold fluid mass, 1056.  
 Boecardi, G., Staining Nerve-terminations with Chloride of Gold, 155, 674.  
 Boehm, J., Respiration of the Potato, 85.  
 Bohemia, Hansgirg's Alga-flora of, 626.  
 Bokorny, S., Action of basic substances on living Protoplasm, 758.  
 — — —, Formation of Starch from various substances, 771.  
 — — —, Separation of Silver by active Albumin, 244.  
 Bokorny, T., and O. Loew, Presence of active Albumin in the Cell-sap, 246.  
 — — —, Chemico-physiological Study of Algae, 463.  
 Bolton, M., Method of preparing Potatoes for Bacterial Cultures, 143.  
 Bombaceae, &c., Comparative Anatomy of, 606.  
 Bombyx mori, Aorta of, 212.  
 — — —, Parthenogenesis in, 571, 725.  
 Bond, G. M., Standards of Length and their practical application, 503.  
 Bone and Teeth, Method for making Preparations of, and retaining their soft parts, 1042.  
 — — —, Preparing Sections of, 147.  
 Bone-corpuscles, Demonstrating the Canalicular Prolongations of, 661.  
 — — —-development, Staining in the Study of, 844.  
 Bonnet, H., Parasitism of the Truffle, 780.  
 Bonnier, G., Comparative Cultures of the same species at different altitudes, 999.  
 — — —, J., and A. Giard, Bopyridæ, 216.  
 — — —, New Species of Ceponinæ, 731.  
 — — —, Two New Genera of Epicarida, 217.  
 Boodle, L. A., and A. Calvert, Laticiferous System of Manihot and Hevea, 72.  
 — — —, and G. Murray, Spongocladia, 1002.  
 Bopyridæ, 216.  
 Borden, W. C., Alcoholic Alum-carmino Stain, 517.  
 — — —, Carmine Injections, 677.  
 Bordered Pit Membranes &c., Staining, 675.  
 Bordoni-Uffreduzzi, G., New Pathogenic Microphyte in Men and Animals, 634.  
 — — —, The culture of the leprosy bacillus, 1040.  
 Boring Clionids, 965.  
 Bornet, E., and C. Flahault, Filamentous Heterocystous Nostochinæ, 472.  
 — — —, New Genera of Perforating Algae, 776.  
 Borragineæ, Fruit of, 255.  
 Borzi, A., Chlorothecium, 1012.  
 — — —, Development of *Mischococcus confervicola*, 632.  
 — — —, Formation of Lateral Roots in Monocotyledones, 762.  
 — — —, Microchete, 275.  
 Botany, Application of Paraffin Imbedding in, 315.  
 Botteher's Gas-chamber, 288.  
 Bottle, Doty's Balsam, 163.  
 Bottle-cultivation, 143.  
 Boudier, E., Conidiferous Form of *Polyporus bicinnis*, 778.  
 — — —, New *Mucedinæ*, 631.  
 — — —, *Pilaere*, 1009.  
 — — —, *Tremella fimetaria*, 270.  
 Boulger, G. S., Endosperm, 446.  
 Bourne, A. G., Vascular System of Hirudinea, 219.  
 — — —, J. C., Kleinenberg on Development of *Lopolarhynchus*, 579.  
 Bouvier, E. L., Anatomy and Affinities of *Ampullaria*, 204.  
 — — —, Nervous System of Prosobranchs, 21.  
 Boveri, T., Cell-studies, 552.  
 — — —, Method of Preparing the Eggs of *Ascaris megalocephala*, 664.  
 — — —, Polar Globules of *Ascaris*, 425.  
 Bovista, Revision of the genus, 629.  
 Bower, F. O., Formation of Gemmæ in *Trichomanes*, 262.  
 — — —, *Humboldtia laurifolia* as a myrmecophilous Plant, 88.  
 — — —, Modes of Climbing in the genus *Calamus*, 258.  
 — — —, Morphological Peculiarity of *Cordylina australis*, 81.  
 — — —, Oophyte of *Trichomanes*, 617.  
 — — —, Practical Instruction in Botany, 1060.  
 Bowman, F. H., Does Science aid Faith? 654.  
 Box, Chemical Substances contained in, 72.  
 Brachyurous Crustacea, Excretion in, 216.  
 Bracts of Cruciferæ, 609.  
 Brady, H. B., Note on the Reproductive Condition of *Orbitolites complanata*, var. *laciniata*, 693, 1065.  
 Braem, F., Fresh-water Bryozoa, 937.

- Brain Markings, 822.  
 — of *Iulus*, 408.  
 — of *Phalangida*, 576.  
 — of *Phylloxera*, 408.  
 — of *Somomya*, 407, 944.  
 —, Sublimate as a Hardening Medium for, 831.  
 Brains and other Organs, Preparation of, 507.  
 Bramwell, B., Half-clearing method of preparing Nerve Sections, 680.  
 Branches and Inflorescences, Anatomy of Annual, 451.  
 Branchioma, Structure of the Eye of, 219.  
 Braudes, G., *Holostomum*, 954.  
 Brandt, E., Larva of *Sarcophila Wohlfartii* in Gum of Man, 944.  
 —, *Tænia cucumerina* in Man, 955.  
 —, K., Preparing Spherozoa, 665.  
*Brasenia peltata*, Vegetative Organs of, 449.  
 Brauns, R., Simple Method for clearing Methylene Iodide, 677.  
 Brazil, Remarkable Ophiurid from, 591.  
 Brefeld, O., Classification of Basidiomycetes, 778.  
*Brefeldia* and *Badhamia*, Plasmodium of, 783.  
 Brenstein, G., Action of Ether on Plant-life, 773.  
 Bret, Colouring matter of the waters of the Lake of, 785.  
 Brewing, Analysis of Water used for, as regards Micro-organisms, 685.  
 Briggs, D. H., Beautiful Micro-polariscope Objects, 523.  
 British Oribatidæ, 412.  
 Brock, J., So-called Eyes of *Tridacna* and occurrence of Pseudochlorophyll Corpuscles in the Vascular System of *Lamellibranchs*, 564.  
 —, Systematic Arrangement of Cranchia, 397.  
 Brook, G., Germinal Layers in Teleostei, 189.  
 —, Reproduction of Lost Parts, 414.  
 Brooklyn Microscopical Society, 304.  
 Brooks, W. K., Life-history of *Epenthesis McCradyi*, n. sp., 743.  
 —, New Method of Multiplication in Hydroids, 433.  
 Brown, F. W., A Course in Animal History, 324, 523, 686, 855.  
 Brownian Movement, Preparing Slides to show, 833.  
 Bruce, A. F., Embryology of Insects and Arachnids, 567.  
 Bruce's (A.) Microtome for cutting whole sections of the Brain and other organs, 837.  
 Bruck, T., Morphology of Underground Stems, 450.  
 Brun, J., Notes on microscopical technique applied to natural history, 166.  
 Brunchorst, J., Cabbage-Hernia, 273.  
 —, Fungus Parasitic on the Salt-fish, 781.  
 —, New Potato-disease, 471.  
 —, Potato Fungus, 274.  
 Brunotte, C., Structure of the Eye of *Branchioma*, 219.  
 Brunton, L., B. Sanderson, and M. Foster, Manual of the Physiological Laboratory, 686.  
 Bruyne, C. de, Nature of Contractile Vacuole, 749.  
 —, New Monad, *Endobiella Bambekii*, 972.  
 Bryan, G. H., Mounting in Canada Balsam by the Exposure Method, 160.  
 Bryozoa. See Contents, xi.  
 Buchner, H., T. Longard, and G. Riedlin, Method of calculating the rapidity of Bacterial Increase, 682.  
 —, New Method for Cultivating Anaerobic Micro-organisms, 1037.  
 —, Supposed Spores of the Typhoid Bacillus, 1016.  
 Buchtien, O., Prothallium of *Equisetum*, 262.  
 Bud, Development of Flowers in, 610.  
 Budding in Star-fishes, 233.  
 Buds on Roots and Secondary Roots, Arrangement of, 80.  
 —, Preparing Sections of, 511.  
 —, Protection of, 989.  
 Buffalo Microscopical Club, 485.  
 — Society of Natural Sciences, Microscopical Club of, 305.  
 Buffham, T. H., Arranging Slides, 161.  
 Buijwid, O., Bacteria in Hailstones, 277.  
*Bulbotrichia*, 1003.  
 Bulbs, Mechanical Protection of, 607.  
 Bumpus, H. C., Inexpensive Section-smoother, 670.  
*Bupleurum*, Leaves of, 608.  
 Burek, W., Heterostylism and Self-fertilization, 453.  
 Burgerstein, A., Literature of Transpiration, 259.  
 Burrows, H. W., C. D. Sherborn, and G. Bailey, The Foraminifera of the Red Chalk, 383.  
 Burstert's (H.) Photomicrographic Apparatus, 808.  
 Bury, H., Development of *Antedon rosacea*, 232.  
 Buscalioni, L., and O. Mattirollo, Root-tubercles of Leguminosæ, 251.  
 Bütschli, O., Development of *Musca*, 944.  
 —, Growth by Intussusception, 557.  
 —, Phylogeny of Protozoa, 967.  
 — Protozoa, 597.  
 Butterflies and Moths, Villi on the Scales of, 498.  
 —, Basal Spot on Palps of, 943.  
 Butterfly Scales, Finer Structure of, 405.  
 Bye Laws, Alterations in, 170.  
 Byssus, Formation of, 935.

## C.

- Cabbage-hernia, 273.  
 Calamus, Modes of Climbing in the genus, 258.  
 Calandruccio, S., and B. Grassi, Echinorhynchus parasitic in Man, and whose intermediary host is a Blaps, 739.  
 Calcareous Corpuscles of Holothurians, 58.  
 — Incrustations on Fresh-water Plants, Deposition of, 773.  
 — Sponges, Skeleton of, 63.  
 Calcium oxalate, Crystals of, 445.  
 Calcutta Microscopical Society, 503.  
 Calloni, S., Ovnules of Rumex, 764.  
 Callus. Microchemical Tests for, 323.  
 Calopogon parviflorus, Fertilization of, 454.  
 Calostoma Desv. (Mitremyces Nees), 780.  
 Calvert, A., and L. A. Boodle, Laticiferous System of Manihot and Hevea, 72.  
 Cambridge Rocking Microtome, Accessory to, 669.  
 Camera, Griffith's Photomicrographic, 1031.  
 —, Neuhaus's Photomicrographic, 293.  
 —, Stegemann's Photomicrographic, 116.  
 — Lucida, Dumaige's, 487.  
 — — —, Large form of Abbe, 113.  
 — — —, Screen for the Abbe, 809.  
 Camerano, L., Life-history of Gordius, 228.  
 —. Structure and Position of Gordiaceæ, 737.  
 Cameras, Marktanner's Photomicrographic, 117.  
 Campani's (J.) Compound Microscopes, 109.  
 Campbell, D. H., Development of Onoclea Struthiopteris, Hoffm. (Struthiopteris germanica, Willd.), 618.  
 —, Paraffin-embedding method for vegetable objects, 672, 1049  
 — — — — — Process in Botany, 834.  
 Camponotus lateralis, Parasitism and Mimicry of, 30.  
 Canada Balsam, Mounting in, by the Exposure Method, 160.  
 Cancer Bacillus, Scheurle's, 472, 785.  
 Canna, Morphology of the Flowers of, 611.  
 Cannula-holder, Collin's Automatic, 680.  
 Capillary Slide and accessories for the examination of Ova, 801.  
 Capitellidæ, Monograph of, 418.  
 Capranica, S., Instantaneous Photomicrography, 651.  
 Caprifoliaceæ, Super-endodermal Network in the Root of, 73.  
 Carboniferous Foraminifera, 533.  
 Carbohydrates, Daily Assimilation of, 994.  
 Carcinus Mænas, Supra-oesophageal Ganglia of, Effects of Lesions of, 730.  
 Cardiac Body of Annelids, 418.  
 Carini, A., Maturity of the Ovum, 15.  
 Carlet, G., Mode of Locomotion of Caterpillars, 726.  
 —, Poison of Hymenoptera, 724.  
 Carmine Injections, 677.  
 — Stain, Alcoholic Alum, 217.  
 Carnoy, J. B., Maturation and Division of Ascaris Ova, 42.  
 —, Polar Bodies in Ascaris, 43.  
 Carpenter, P. H., 'Challenger' Comatulæ, 962.  
 —, Development of Apical Plates in Amphura squamata, 58.  
 Carter, H. J., Nature of Opaque Scarlet Spherules found in many Fossilized Foraminifera, 438.  
 —, Observations on Parkeria, 757.  
 Casagrande, D., Alimentary Canal in Metamorphosis, 943.  
 Castracane, F., Deep-sea Diatoms, 94.  
 Castration of the Cray-fish, 947.  
 —, Parasitic, in the Eucyphotes of Palemon and Hippolyte, 414.  
 Caterpillars and Adult Insects, Vision of, 404.  
 —, Mode of Locomotion of, 726.  
 Cathcart Improved Microtome, 1047.  
 Cattaneo, G., Amœboocytes of Crustacea, 949.  
 —, Intestine and Digestive Glands of Decapods, 729.  
 —, New Parasitic Ciliated Infusorian, 971.  
 Cattleya labiata, Fertilization of, 994.  
 Caulerpa, Rejuvenescence of, 464.  
 Cœcidium of Nematode Capreæ, 458.  
 Cedar-apple, Anatomy of the Common, 631.  
 Cell and Nuclear Division, 243, 440.  
 —, Apical of Fucus, 621.  
 —, Division of the Nucleus and, 978.  
 —, Flemming, on the, 553.  
 —, Morphology of, 17.  
 —, — and Physiology of, 442.  
 —, Physiology of, 758.  
 Cell-division, 18, 554 712.  
 — — —, Impregnation, and Division of the Nucleus, 600.  
 — — —, Part taken by the Nucleus in, 69.  
 — -granules, Demonstrating, 146.  
 — — — Vital, Methylene-blue Reaction of, 842.  
 — -membrane, 712  
 — — — and Gelatinous Envelope of Desmidiæ, 1004.  
 — -nucleus, Pathological Structure of, 391.  
 — -sap, Active Albumin in, 246.  
 — -studies, 552.  
 — -wall, Albumen in, 69, 982.  
 — — —, Albuminous reaction of, 602.  
 — — — in Mosses, Absorption of Water and its Relation to the Constitution of, 263.  
 — — — of Acetabularia, Incrustation of, 463.

- Cell-wall, Structure and Growth of, 441, 442.  
 — walls, Pleochromism of Coloured, 602.  
 — —, Thickening of, in the Leaf-stalk of *Aralia*, 70.  
 Cellar Bacteria, 1014.  
 Celloidin Corrosion Mass, Modification of Schiefferdecker's, 159.  
 —, Preparing Long Series of Sections with, 670.  
 — Technique, Further Notes on, 836.  
 Celloidin-paraffin Methods of Imbedding, 512.  
 Cells and Tissues, 710.  
 —, Anomalous, in the Interior of the Tissue of Fossil Plants, 605.  
 —, Contractility of the Protoplasm of Certain, 457.  
 —, destitute of Starch, Action of Formose on, 85.  
 —, Epidermal, Influence of the Turgidity of, on the Stomata, 605, 763.  
 —, Forms of, 758.  
 —, Glandular, of Stomach, 393.  
 —, Interstitial, of the Ovary, Reticulated Protoplasm in, 311.  
 —, living Animal, Absorption of Anilin Pigments by, 1055.  
 —, Lymphatic, Fusion of, into Plasmodia, 555.  
 —, Methyl-green for observing the chemical Reaction and Death of, 1043.  
 —, Mucous, in Mussels, 402.  
 —, Muscle, Nuclei of, 18.  
 — of the Aril of the Nutmeg, Contents of, 760.  
 —, plant, Properties and changes of the Membrane, Protoplasm, and Nucleus of, 980.  
 —, Power of Contractility exhibited by the Protoplasm of certain, 614.  
 —, Secreting, of Intestinal Epithelium, 553.  
 —, Sexual, and Early Stages in Development of *Millepora plicata*, 964.  
 —, Solitary, Principle of Heredity and the Laws of Mechanics applied to the Morphology of, 926.  
 —, Spinal Ganglion, 556.  
 —, Tubular, of the *Fumariaceæ*, 73.  
 —, Wall of Suberosus, 985.  
 —, Wandering, Division and Metamorphosis of, 393.  
 —, Wax, 519.  
 Cellular Envelope of the Filamentous *Nostocaceæ*, 632.  
 — Statics, 555.  
 Cellulose, Congo-red as a reagent for, 1053.  
 Cement, Preparation of fluid, 1057.  
 —, Shellac, 520.  
 Centering, Continuous, of a Cover-glass, 850.  
 Centrolepidæ, Roots and Rootlets, 251.  
 Cephalopoda. See Contents, x.  
*Ceponinæ*, New Species of, 731.  
*Cerianthus* and *Arachnactis*, 743.  
*Ceriumyces* and *Fibrillaria*, 630.  
*Cestoda*, Development of Generative Organs of, 426.  
 Cestoid Embryos, 46.  
 Chabry, L., Capillary Slide and Accessories for the Examination of Ova, 801.  
*Chaetoceros*, 627.  
*Chaetognatha*, Spermatogenesis in, 227.  
*Chaetopterus Valencini*, Nervous System of, 225.  
*Chalininæ*, New System of, 63.  
 'Challenger' Actiniaria, Supplementary Report on, 965.  
 — *Comatulæ*, 962.  
 — *Crustacea Macrura*, 948.  
 — *Cumaceæ*, 35.  
 — *Hexactinellida*, 597, 747.  
 — *Myzostomida*, 590.  
 — *Nemertea*, 52.  
 — *Phyllocarida*, 36.  
 — *Pteropoda (Gymnosomata)*, 26.  
 — Sponges, 597.  
*Champia parvula*, Frond of, 623.  
 Chaney, H. J., Micromillimetre, 502.  
*Chautransia*, *Batrachospermum* and *Lemanea*, 464.  
 Chapman, E. T., Slide for Observing Soap-bubble Films, 647.  
 Chara, New, 1001.  
*Characeæ*, Collecting and Preparing, 828.  
 —. See Contents, xvii.  
 Characters, Inheritance of Acquired, 193.  
 Chatin, J., *Anguillulidæ* of the Onion, 585.  
 —, Integument of *Heterodera Schaectii*, 738.  
 —, Myelocytes of Invertebrates, 929.  
 — Nerve-terminations in *Lepidoptera*, 943.  
 Cheesman, T. L., Preparation of Nutrient Gelatin and Agar, 825.  
*Cheilanthes hirta*, Antherozoids of, 999.  
 Chemical Preparations, Photomicrography of, 293.  
 Chemico-physiological Study of *Algæ*, 463.  
 Chemistry of Germination, 767.  
 — of the Nucleus, 390.  
 Chemotactic Movements of Bacteria, *Flagellata*, and *Volvocineæ*, 770.  
*Chermes*, Some Species of, 213.  
 Cherry and Plum-trees, Disease affecting, 274.  
 Chevreux, E., and J. de Guerne, New Commensal Amphipod, 416.  
 —, *Orchestia*, 949.  
 Chiaragi, G., Preparing Sections of Bone, 147.  
 —, Demonstrating the Canalicular Prolongations of Bone-corpuscles, 661.  
 Chick, Development of Blood-vascular System of, 187.  
 —, First Branchial Cleft of, 387.  
 Chitin Solvents, 833.

- Chitonidæ, Structure and Development of Egg in, 933.
- Chlamydococcus pluvialis, 1004.
- Chlamydomonas, 1004.
- Chlorogonium, 1003.
- Chlorophyceæ. Classification of, 775.
- , Venetian, 627.
- Chlorophyll, Assimilation in Plants destitute of, 455.
- , Epidermal, 245.
- , Fluorescence of, 245.
- , Function of the Colouring Matter of, 997.
- , Organs for the absorption of vegetable food-material by plants containing, 249.
- , Preparation of Pure, 245.
- , Quantitative estimation of, 71.
- Chlorophyll-grains, Formation of Starch in, 983.
- — — and Starch-grains, 70.
- -granules, Formation of Starch in, 71.
- Chlorothecium, 1012.
- Chlorozoosporeæ, Uronema, A New Genus of, 626.
- Chodat, R., Diagram of the Flower of Crucifere, 611.
- Cholera spirilla, &c., Spore-formation in, 1016.
- Cholodkovsky, N., Development of Endoderm of *Blatta germanica*, 406.
- , Some Species of Chermes, 213.
- Choristocarpus tenellus, 93.
- Chrapowitzki, —, Synthesis of Albuminoids, 455.
- Christy, T., Koch's and Max Wolz's Reflector, 1025.
- Chromatology of Sponges, 595.
- Chromic Acid and Safranin, Staining of Elastic Fibres with, 1053.
- Chromo-aromatic Microbe, 634.
- Chrysalis, Diminution in Weight of, 31.
- Chun, C., Morphology of Siphonophora, 59.
- , Pelagic Animals at Great Depths, and their Relations to the Surface Fauna, 558.
- Churchill, Lord E., Photomicrographic Apparatus, 1061.
- Chytridiacea parasitic on Diatoms, 99.
- Chytridium elegans, n. sp., a Parasite of the Rotatoria, 1011.
- , New, 1011.
- Ciaccio, G. V., Eyes of Diptera, 31.
- Cianci, C., and G. Angiolilla, Structure of Red Blood-corpuscles, 928.
- Ciliary Movement, 971.
- Cirriped, New, 417.
- Cladocera, and greatest depth at which found, 578.
- Cladonemidæ, 235.
- Cladonia, 621.
- Cladotrix dichotoma, Cultures of, 784.
- Clarke, C. B., Root-pressure, 769.
- , S. F., Eggs of Alligator lucius, 925.
- Clark, J., Ciliary Movement, 971.
- Clathrospora and Pyrenophora, 631.
- Claus, C., Apsendes and the Tanaidæ, 416.
- , Lernæaceus and the Philichthyidæ, 217.
- Clearing, Substitute for, 160.
- Cleistogamy and Self-fertilization in Orchids, 994.
- Clematis, Split Xylem in, 248.
- Clepsine, Germ-layers of, 37.
- Climate, Influence of, on the Cuticularization and Thickening of the Leaves of some Coniferæ, 608.
- Climbing, Modes of, in the genus *Calamus*, 258.
- Clinging-Plants, 253.
- Clionæ, So-called Peripheral Prolongations of, 239.
- Clionids, Boring, 965.
- Cockroach, Salivary Glands of, 725.
- Cœlenterata. See Contents, xviii.
- Cœlom and Embryonic Layers of a Limicolous Oligochaete, Formation of, 735.
- and Vascular System of Mollusca and Arthropoda, 395.
- Cohn's Cryptogamic Flora of Silesia (Fungi), 99.
- Cole's (A. C.) Microscopical Preparations, 523.
- Collin, A., *Criodrilus lacuum*, 733.
- , Preparation of *Criodrilus lacuum*, 832.
- (C.), Aquarium Microscope, 103.
- Automatic Cannula-holder, 680.
- Collodion for Imbedding in Embryology, 667.
- Colomb, G., Stipules, 252.
- Coloration of Fungi, Blue, by Iodine, 628.
- Colour changes in Spiders, Relations of Structure and Function to, 945.
- Colour-reaction; its use to the Microscopist and to the Biologist, 320.
- -relation between Pupæ and Surroundings, 727.
- -test, Roux's, for the detection of Gonococcus, 517.
- Coloured Nutrient Media, new method of cultivating Bacteria in, 1039.
- Colouring Matter of the Waters of the Lake of Bret, 785.
- Colours of Corals, 60.
- of Leaves and Fruits, 254.
- Colpoda, Various Cyst-formations and Developmental History of, 969.
- Comatula, Development of, 960.
- Comatulæ, 'Challenger,' 962.
- Comes, O., Mal nero of the Vine, 762.
- Comothyrium diplodiella, Grape-disease, 98.
- "Compensation Eye-piece 6 with 1/1 Micron-division," Zeiss's, 797.
- Compositæ, Oil-passages in the Roots of, 447.
- , Oil-receptacles in the Roots of, 760.
- "Compressorium," Hallstén's, 489.
- , Rowland's Reversible, 803.

- Condenser, new Combination, 334.  
 Conferoideæ, Classification of, 775.  
 —, Development of, 266.  
 Congo-red as a Re-agent for Cellulose, 1053.  
 — — — — — for Free Acid, 1055.  
 Conidiferous Form of *Polyporus biennis*, 778.  
 Coniferæ, Demonstrating the Membrane of the Bordered Pits in, 155.  
 —, Influence of Climate on the Cuticularization and Thickening of the Leaves of some, 608.  
 —, Lateralness in, 78.  
 —, Structure of the Leaves of certain of, 451.  
 Conjugatæ, Zygosporæ of, 1002.  
 Conjugation of *Paramæcium*, 65.  
 — of *Spirogyra*, 625.  
 — of *Vorticellidæ*, 752.  
 Continental Fine-adjustment, Pritchard's Microscope with, 1022.  
 Contractility of the Protoplasm of certain Cells, 457.  
 —, Power of, exhibited by the Protoplasm of certain Cells, 614.  
 Cook, A. J., Morphology of the Legs of Hymenoptera, 725.  
 Cooke, —, Photomicrographs of the Odontophores of Mollusca, 333.  
 Cooler for quickly setting Gelatin Plates, 828.  
 Copepod, New Parasitic, 417.  
 Coplin, —, Brief Directions for Using the Microscopical Mounting Outfit (Jefferson design), 322.  
 Copper-hæmatoxylin, Benda's Modified, 158.  
 Corals, Colours of, 60.  
 Cordyline australis, Morphological Peculiarity of, 81.  
 Corin, G., and E. Berard, Albuminoid Constituents of White of Egg, 551.  
 Corpuscles, Amœboid, in the Star-fish, Emigration of, 431.  
 —, Calcareous, of Holothurians, 58.  
 Corrosion Mass, Modification of Schieffer-decker's Celloidin, 159.  
 — Surfaces, Measuring, in Iron Pyrites, 803.  
 Corsica, Protozoa of, 755.  
 Cosmovici, L. C., Contractile Vesicle of Rotifers, 955.  
 Costantin, J., *Diplocladium*, 1009.  
 —, Heterobasidial Basidiomycetes, 1006.  
 —, New *Papulaspora*, 631.  
 —, Parasites of the Higher Fungi, 1011.  
 —, and Rolland, —, *Stysanus* and *Hormodendron*, 1010.  
 Coulter, J. M., and J. N. Rose, Development of the Fruit of *Umbelliferæ*, 79.  
 Council, Report of, for 1887, 330.  
 Couvreur, E., The Microscope and its applications to the study of plants and animals, 654.  
 Cover-correction, 496.  
 Cover-glass, Adjusting an Objective for the thickness of, 497.  
 — — — Preparations, Simple Method for Fixing, 1047.  
 — — —, Continuous Centering of a, 850.  
 Cox, C. F., American Microscopes, 652.  
 Crab, Effects of Lesions of the Supra-œsophageal Ganglia of, 730.  
 Crabs' Claws, Innervation of, 947.  
 —, Male appendages on Female, 730.  
 — of Africa, Fresh-water, 415.  
 Cramer, C., *Dasycladaceæ*, 464.  
 Cranchia, Systematic Arrangement of, 397.  
 Crangon, Development of the Compound Eye of, 34.  
 —, Methods of studying Development of Eye of, 148.  
 Crassulaceæ, Tannin in, 603.  
 Crayfish, Castration of, 947.  
 —, Green Gland of, 216.  
 Crayfishes, Digestion in, 947.  
 —, Interoxal Lobe of certain, 577.  
 Creeping Movements of Earthworm, 952.  
 — — —, in Gastropods, 718.  
 Crépin, F., Polymorphism attributed to certain generic groups, 453.  
*Cribrella ocellata*, Madreporite of, 431.  
*Criodrilus*, Excretory Organs of, 953.  
 — lacuum, 733.  
 — — —, Preparation of, 832.  
 Crisp, F., Ancient Microscopes, 304.  
 —, Micromillimetre, 652.  
 Cristatella, Method of investigating, 147.  
 — mucedo, 936.  
 Cross, C. F., Indian Fibres, 495.  
 Cross-fertilization, 993.  
 — — —, Adaptation of the Flowers of *Eremurus altaicus* to, 767.  
 — — — on Inconspicuous Flowers, Effect of, 612.  
 Crossing, Production of Sex and Phenomena of, 256.  
 Cruciferæ, Bracts of, 609.  
 —, Diagram of the Flower of, 611.  
 —, Replum in, 611.  
 Cruciferous Plants, Substance containing Sulphur in, 997.  
 Crustacea. See Contents, xiv.  
 Cryptogamia. See Contents, xxvi.  
*Cryptomonadineæ*, 754.  
 Crystal Palace Photographic Exhibition, 296.  
 Crystal-plastids, 243.  
 Crystalline Style, 566.  
 Crystalloids in Marine Algae, 463.  
 Crystals, Methæmoglobin, 506.  
 — of Calcium oxalate, 445.  
 Cuboni, G., *Peronospora* of the Rose, 1008.  
 —, viticola, 1008.  
 Cuccati, G., Alcoholic Solution of Hæmatoxylin, 846.  
 —, Brain of *Somomya*, 944.  
 —, J., Organization of Brain of *Somomya erythrocephala*, 407.

- Cuénot, L., Anatomy of Ophiurids, 958.  
 —, Blood of Invertebrata, 557.  
 —, Development of Red Blood-corpuscles, 395.  
 —, Nervous System and Vascular Apparatus of Ophiurids, 57.  
 Cultures, Comparative, of the same species at different altitudes, 999.  
 Cugini, G., Fluorescence of Chlorophyll, 245.  
 Culex, Larva of, 212.  
 Culture Processes. See Contents, xxxv.  
 — Test for Micro-organisms of Water, Gelatin, 855.  
 — Tubes, Geissler's, 287.  
 Cultures of certain Microbes, Presence of a Phlogogenous matter in, 634.  
 — of *Cladotrix dichotoma*, 784.  
 Cunaeca, 'Challenger,' 35.  
 Cunningham, J. T., Anatomy of Polychaeta, 41.  
 —, Eggs and Larvæ of Teleosteans, 191.  
 —, Nephridia of *Lanice conchilega*, 735.  
 —, Ova of *Idellostoma*, 192.  
 —, and R. Vallentin, *Photospheria* of *Nyctiphanes norvegica*, 415.  
 —, K. M., Collecting and Cleaning Diatoms, 143.  
 "Curiosities of Microscopical Literature," 140.  
 Curiosities of the Senses, 500.  
 "Curl" of Peach-leaves, 89.  
 Curties, C. L., New Combination Condenser, 334.  
 Curtis, C., The Tapeworm: methods of preparing, 511.  
 —, J. S., The Quantitative Determination of Silver by means of the Microscope, 494.  
 Curvature of Plants, 769.  
 Cuticularization and Thickening of the Leaves of some Coniferae, Influence of Climate on, 608.  
 Cuttle-fishes, Some Oigopsid, 931.  
 Cycas, Anomalous Thickening in the Roots of, 75.  
 —, Rooting of the Albumen of, 988.  
 Cyclamen, Alkaloid and Sugar in, 759.  
 Cyclostoma elegans, Anatomy and Histology of, 716.  
 Cymothoidæ, Eyes of, 730.  
 Cyprida, so-called Mucous Gland of Male, 731.  
 Cypridina, Structure of, 36.  
 Cypridiuæ, Preparation of, 508.  
 Cyst-formations, Various, and Developmental History of Colpoda, 970.  
 Cystids, Function of, 96.  
 Cystocarp and Procarp of *Gracilaria*, 622.  
 Czapcki, S., Bamberg's Spherometer Microscope, 280.  
 —, Remarks on Prof. Abbe's paper: The magnifying power of a lens or a lens-system, 500.
- D.  
 D., M. T., Microscopical Drawings, 500.  
 Daae, H., Spinal Ganglion-cells, 556.  
 D'Abbadie, A., Micromillimetre, 503.  
 D'Abundo, G., Staining Cultivation Media and its results on micro-organisms, 319.  
 Daccamo, G., Aspidol from *Aspidium Filix-mas*, 619.  
 Daday, E. v., Monograph of Tintinnodea, 436.  
 D'Agén, E., Initial Magnifying Power of Microscope Objectives, 1035.  
 Daguillon, A., Structure of the Leaves of certain of the Coniferae, 451.  
 Dal Pozzo, D., The albumen of plover's egg as a culture medium for micro-organisms, 311, 1037.  
 Dale's (H. F.) Microtome, 317.  
 Dallinger, W. H., Advantages of a Knowledge of the Theory of the Microscope, 296.  
 —, Daylight or Lamplight for Microscopical Observation, 302.  
 —, Least and simplest forms of Life, 503.  
 —, Memoir, 822.  
 —, Presentation to, 822.  
 —, President's Address, 177.  
 —, Retirement of, 327.  
 Dammer, U., Adaptation of the Flowers of *Eremurus altaicus* to Cross-fertilization, 767.  
 Dancer, J. B., Death of, 140.  
 Dangeard, P. A., Anatomy of the Salsolææ, 988.  
 —, *Chlamydococcus pluvialis*, 1004.  
 —, *Chlamydomonas*, 1004.  
 —, *Chlorogonium*, 1003.  
 —, *Cryptomonadinae*, 754.  
 —, Foliar Sheath of the *Salicorniææ*, 609.  
 —, Importance of the Mode of Nutrition as a means of Distinction between Animals and Vegetables, 257.  
 —, Mycological Notes, 783.  
 —, Observations on *Pinguicula*, 987.  
 —, Parasites of the *Peridinieæ*, 781.  
 —, Reproduction of *Nephrocystium*, 1013.  
 —, Secretory Canals of *Arancaria*, 986.  
 —, and Barbé, —, Arrangement of the Fibro-vascular Bundles in *Pinguicula*, 74.  
 Daphnidæ, European, 919.  
 Darwin, F., and A. Bateson, Method of studying Geotropism, 770.  
 Dasycladaceæ, 464.  
 Dawson, J. W., Eozoon Canadense, 241.  
 Daylight or Lamplight for Microscopical Observation, 302.  
 Debray, F., Development of the Thallus of certain Alge, 265.  
 Deby, J., Dipterous Insect from Biarritz, 687.

- Deby, J., Myrmecophilous Plants, 688.
- Decapods, Intestine and Digestive Glands of, 729.
- Decortication of Trees, Effects produced by the Annular, 447.
- Defence, Secretion of Pure Aqueous Formic Acid by Lepidopterous Larvæ for the Purposes of, 405.
- Deformations, Artificial, of the Nucleus, 196.
- Degagny, C., Nuclear Origin of Hyaloplasm, 440.
- Degeneration, 194.
- Deliscence of the Sporangium of Ferns, 90.
- Dekhuizen, M. C., Action of Staining, 158.
- Delagia Chætopteri, 936.
- Delpino, F., Floral Nectary of *Symphoricarpos*, 255.
- , Myrmecophilous Plants, 998.
- Dendrocœla, Embryogeny of Fresh-water, 586.
- Dendy, A., Comparative Anatomy of Sponges, 594.
- , New System of Chalininæ, 63.
- , and S. O. Ridley, 'Challenger' Sponges, 597.
- Dennert, E., Anatomy of *Nelumbium*, 765.
- Dentalium, Organization of, 933.
- Dentist's Examining Glass, 795.
- Dermal Sensory Organs of Insects, 210, 569.
- Desert Flora, 617.
- Desmidiæ, Cell-membrane and Gelatinous Envelope of, 1004.
- Detmer, W., Inheritance of Acquired Characters, 193.
- , Laboratory Course of Vegetable Physiology, 617, 686.
- , Physiological Oxidation in the Protoplasm, 454.
- Detmers, H. J., American and Foreign Microscopes; the Verdict of an Impartial Expert, 798.
- De Toni, D., and G. B. Levi's Venetian Chlorophyceæ, 627.
- Devaux, —, Action of Light on Roots grown in Water, 995.
- Development of Compound Eye of Crangon, 34.
- , —, Methods of Studying, 148.
- of *Helix* Waltoni, 24.
- of *Peripatus* Novæ-Zelandiæ, 33.
- of Spermatozoa in *Murex*, 200.
- of *Vermetus*, 201.
- , See Embryology in Contents, vii.
- Devoletzky, R., Lateral Organs of Nematodes, 51.
- Dewitz, H., Simple Method of Warming and Cooling under the Microscope, 113.
- Diakonow, N. W., Apparatus for Infecting, 829.
- , Vessel for the Culture of Low Organisms, 657.
- Diaphragm, Zeiss's Iris, 111.
- Diaphragms in the Air-canals of the Root, 447.
- Diaptomus, Geographical Distribution of, 731.
- Diastase, 997.
- Diatom-Structure, On the Formation of, 495.
- , —, Some points in, 94.
- Diatomacœ, 667.
- Diatoms, Arranged Slide of, 1057.
- , Chytridiacea parasitic on, 99.
- , Collecting and Cleaning, 143.
- , Deep-sea, 94.
- , Formation of Auxospores in, 268.
- , Fossil Marine, from New Zealand, 94.
- , —, of Hungary, 466.
- from a Trygon, 777.
- , Photomicrographs of, 295.
- , Staining, 156.
- , Tempère's Preparations of, 667.
- Dichotomy, 78.
- Dicotyledons, Anomalies in the Structure of the Roots of, 606.
- , Formation of Endosperm in, 765.
- , Petiole of, 610.
- Dietel, P., Uredinæ, 97.
- , — and their Hosts, 1007.
- Dietz, S., Flowers and Fruit of *Sparganium* and *Typha*, 78.
- Diez, R., Vernation of Leaves, 252.
- Differential Screw Slow Motion, 110.
- Diffraction Spectra, 652.
- Theory and Histological Structures, 119.
- Digestion in Cray-fishes, 947.
- in Rhizopods, 240.
- Digestive and Intestine Glands of Decapods, 729.
- Dingler, H., Motion of rotating Winged Fruits and Seeds, 612.
- Diomidoff, A., Sublimate as a Hardening Medium for the Brain, 831.
- Dionæa, Electromotive Properties of the Leaf of, 995.
- Diplocladium, 1009.
- Diplocystis Schneideri, 68.
- Diplozoon paradoxum, Generative Apparatus of, 427.
- Diptera, Eyes of, 31.
- Dipterous Larvæ, Comparative Biology of Necrophagous and Coprophagous, 407.
- Disaggregation of Rocks, 315.
- Discopus Synaptæ, Parasitic Rotifer, 52.
- Disease affecting Cherry and Plum-trees, 274.
- , New, of the Douglas Pine, 471.
- , — Potato, 471.
- , — Vine, 471.
- Diseases and Anatomy of Aurantiacœ, 453.
- Dissecting Dish, 161.
- Distomum, New Human, 49.
- Dixon, H. G., Substage Condensers, 1029.

- Döderlein, L., Echinoidea of Japan, 431.  
 Dolbear, A. E., The Art of Projecting; a Manual of Experimentation, &c., 1036.  
 Dolley, C. S., Histology of *Salpa*, 207.  
 Domatia, 87.  
*Dorocidaris papillata* and other Mediterranean Echinids, Researches on, 430.  
 Dorsal Appendages, 570.  
 Doty's Balsam Bottle, 163.  
 Double Leaves, 253.  
 — Staining, 847.  
 Douglas-pine, New Disease of, 471.  
 Douliot, H., Formation of Periderm, 761.  
 —, Periderm of Leguminosæ, 606.  
 —, — of Rosaceæ, 987.  
 —, and P. v. Tieghem, Plants which form their Rootlets without a Pocket, 987.  
 Dowdeswell, G. F., Photomicrographs of Spermatozoa from the Triton, 1065.  
 Drago, W., Parasite of *Telphusa*, 40.  
 Drawing-board, Eternod's, 798.  
 Drawings, Microscopical, 500.  
 —, Preserving, 822.  
 — v. Photographs, Screen for the Abbe Camera Lucida, 809.  
 Dreyfus, L., Scientific Exhibition at Wiesbaden, 823.  
 —, Reflector, Gauz's Pinakoscope with, 796.  
 Drude, O., Staining Diatoms, 156.  
 Dubief, H., Practical Manual of Microbiology, 686.  
 Dubois, P., Role of Symbiosis in Luminous Marine Animals, 929.  
 —, R., Photogenic Property of *Pholas dactylus*, 26.  
 Duboseq's Projection Microscope, 108.  
 Duchartre, P., Case of Abolition of Geotropism, 996.  
 —, Rooting of the Albumen of Cycas, 988.  
 Dudley, P. H., Faslold's Test Plates, 299.  
 Dufet's (H.) Polarizing Microscope, 107.  
 Dufour, L., Development and Fructification of *Trichocladium*, 630.  
 —, Influence of Light on the Form and Structure of Leaves, 84.  
 Dumaige's Camera Lucida, 487.  
 — Nose-piece for Changing Objectives, 488.  
 — Travelling Microscope, 476.  
 Dumont, A., Comparative Anatomy of Malvaceæ, Bombaceæ, Tiliaceæ, and Sterculiaceæ, 606.  
 Dunlop, J., and H. A. Ward, Fruits and Seeds of *Rhamnus*, 78.  
 Duramen and Protecting-wood, 248, 761.  
 —, Formation of, 446.  
 Durand, W. F., Parasites of *Teredo navalis*, 199.  
 Durdafi, G. N., Contribution to the physiological reaction of methyl-blue, 849.  
 Durham, H. E., Emigration of Amoeboid Corpuscles in the Star-fish, 431.  
 —, Madreporite of *Cribrella ocellata*, 431.  
 Duval, M., Collodion for Imbedding in Embryology, 667.
- E.
- Earthworm, Creeping Movements of, 952.  
 —, New, 222.  
 Earthworms, Experiments on, 580.  
 —, Nephridia of, 421.  
 —, New Australian, 420.  
 —, Structural Characters of, 420.  
 East London Microscopical Society, 503.  
 Ebner, V. v., Skeleton of Calcareous Sponges, 63.  
 —, Spermatogenesis of Mammals, 517.  
 —, and E. Sertoli, Spermatogenesis of Mammals, 707.  
 Eccles, R. G., Thallophytes in Medicinal Solutions, 459.  
 Echinids, Researches on *Dorocidaris papillata* and other Mediterranean, 430.  
 Echinocactus, Irritability of the Stamens of, 261.  
 Echinocardium cordatum, Development of Egg of, 590.  
 Echinodermata, Preparation of, 510.  
 —. See Contents, xvii.  
 Echinoderms, Histology of, 53, 149.  
 Echinorhynchii, Mode of Investigating, 509.  
 —, Structure of, 422.  
 Echinorhynchus parasitic in Man, and whose intermediary host is a Blaps, 739.  
 Echinothuriida, Anatomy of, and Phylogeny of Echinodermata, 956.  
 Echinothurids, Longitudinal Muscles and Stewart's Organ in, 429.  
 Ectoproctous Bryozoa, Embryogeny of, 721.  
 "Edelfaule" of Grapes, 1009.  
 Edmonds's (J.) Automatic Mica Stage, 111, 171.  
 Edmunds, J., Theory of the Microscope—Nägeli and Schwendener, 140.  
 Egbert, S., An Appliance for making Photomicrographs with the Microscope in the upright position, 1033.  
 Ege, J., The value of microscopical examination of Phthisical Sputum as a means of giving a correct Prognosis, 686.  
 Egg, Albuminoid Constituents of White of, 551.  
 — during Maturation and Fecundation, Kinetic Phenomena of, 546.  
 —. Hen's, Trematode in White of newly-laid, 51.  
 — of *Echinocardium cordatum*, Development of, 590.  
 — of Fly, Early Stages in Development of, 573.  
 — of *Musca vomitoria*, Development in, 572.

- Egg, Structure and Development of, in Clitoniidæ, 933.
- Egg-albumen, Alkaline, as a Medium for Bacteria Cultivation, 503.
- membranes of Insects, 722.
- shell of Lepadogaster, 550.
- Eggs, Albumen of Plovers', as Nutrient Medium for Micro-organisms, 1037.
- and Larvæ of Teleosteans, 191, 925.
- for Cultivation purposes, 827.
- , Influence of Movement on Developing, 193.
- of Alligator lucius, 925.
- of Ascaris megaloccephala, Boveri's Method of Preparing, 664.
- — —, Zacharias' Method of Preparing, 663.
- Eichelbaum, F., New Aspergillus, 1008.
- Eidam, E., New Mould, 1010.
- Eiselen, J., Position and Number of Raphides, 445.
- Eisen, G., New Annelid, *Sutroa rostrata*, 582.
- Eiseberg, J., Potato Cultivations, 310.
- Eisig, H., Monograph of the Capitellidæ, 418.
- Elaioplast, 443.
- Elaphomyces, 273.
- Elastic Fibres of the Skin, Staining of, 155.
- Electric Microscope, 285, 1025.
- Electromotive Properties of the Leaf of *Dionæa*, 995.
- Eledone moschata, Spermatozoa of, 560.
- Elimination and Selection, 927.
- Ellenberger, —, Investigating the Effect of Remedies by the Microscope, 1060.
- Elving, F., Curvature of Plants, 769.
- Embryo-sac of Rosaceæ, 610.
- Embryo-chemical Investigations, 551.
- Embryogeny of Ectoproctous Bryozoa, 721.
- of Fresh-water Dendrocœla, 586.
- Embryology. See Contents, vii.
- Embryonic Axis, 923.
- Layers and Cœlom of a Limicolous Oligochæte, Formation of, 735.
- Embryos of Asterias, Preparation of, 1045.
- , Insect, Polypody of, 568.
- Embryoscope, Gerlach's, 491.
- Emergences on the Roots of *Podocarpus*, 252.
- Emery, C., Love-lights of *Luciola*, 30.
- , Mimicry and Parasitism of *Campopotus lateralis*, 30.
- , So-called Digestive Stomach of some Ants, 570.
- Emigration of Amoeboid Corpuseles in the Star-fish, 431.
- Emu, Development of, 187.
- Emulsin in Almonds, Localization of, 247.
- Enchytræidæ, 40.
- , New, 736.
- Encystation of *Megastoma intestinale*, 439.
- Endobiella *Bambekii*, New Monad, 972.
- Endoderm of *Blatta germanica*, Development of, 406.
- Endosperm, 446.
- , Formation of, in Dicotyledons, 765.
- of Gelsomineæ (*Jasmineæ*), 249.
- Endosporous Bacteria, 1014.
- Engelmann, T. W., Bacterio-purpurin, 473.
- , Colouring matter of blood as a means for distinguishing between the gas exchange of plants in light and darkness, 322.
- , Gas Chamber, 288.
- Enock's (F.) Insect Slides, 523.
- Enterosora, 262.
- Entomologists, Young, Microscopic Work for, 511.
- Entomophthoræ of the United States, 1010.
- Environment, Action of, 927.
- Eozoon *Canadense*, 241.
- Epenthesis *McCradyi*, n. sp., Life-history of, 743.
- Epicarida, Two New Genera of, 217.
- Epidermal Chlororophyll, 245.
- Glands, 81.
- Reservoirs for water, 448.
- Epidermis of Leaves, Permeability of, to Gases, 448, 763.
- Epiphytic *Jungermannieæ*, 92.
- Epithelium, Secreting Cells of Intestinal, 556.
- Equisetum, Development of the Root of, 773.
- , Dissemination of the Spores of, 1000.
- , Prothallium of, 262.
- Erdős, J., Accessory for rapid Cutting with the Thoma Microtome, 840.
- , Injection of the Blood-vessels with a cold fluid mass, 1056.
- Eremurus *altaicus*, Adaptation of the Flowers of, to Cross-fertilization, 767.
- and Leguminosæ, Super-endodermal Network of the Root of, 986.
- Ericaceæ, Root-symbiosis in, 86.
- Eriocaulææ, Roots and Rootlets in, 251.
- Ermengem, E. v., Scheurlen's Cancer Bacillus, 785.
- Errera, L., Accumulation and Consumption of Glycogen by Fungi, 96.
- , Cellular Statics, 555.
- , Forms of Cells, 758.
- , Microscopy at the Wiesbaden Exhibition, 140.
- , Photographing Moving Microscopic Objects, 812.
- Essex County Microscopical Society of New Jersey, 304.
- Eternod's (A.) Apparatus for Stretching Membranes, 163.
- Drawing-board, 798.
- Ether, Action of, on Plant-life, 773.
- Eucyphotes of *Palæmon* and *Hippolyte*, Parasitic Castration in, 414.
- Euglena, 754, 972.
- Euglypha, Karyokinesis of, 66.
- Euphrasia, Fertilization of, 767.

- Enplotes harpa*, Direct Division of Nucleus in, 436.  
*Eupomatus elegans*, Embryology of, 578.  
 European Daphniidæ, 949.  
*Euryale ferox*, Flowering of, 83.  
 Ewell, M. D., A Manual of Medical Jurisprudence for the Use of Students at Law and of Medicine, 140.  
 Eurich, —, A contribution to the examination and knowledge of meat, 855.  
 Examinations in Microscopy, 654.  
 Excretion in Brachyurous Crustacea, 216.  
 Excretory Organs of *Criodrilus*, 953.  
 — Systems, Larval and Definite, in Lumbricidæ, 220.  
 Excursion Microscope, Klein's, 1020.  
 Exhalation of Oxygen by Fleshy-leaved Plants in Absence of Carbonic Anhydride, 85.  
 Exner, S., Histological Structures and the Diffraction Theory, 119.  
 Exoderm of the Root of Restiaceæ, 987.  
 Expiration and Assimilation of Plants, 768.  
 Explosive Fruits of *Alstroemeria*, 255.  
 Exposure Method, Mounting in Canada, Balsam by, 160.  
 External Forces, their Influence on the Form of Plants, 456.  
 Eye, Compound, of Crangon, Development of, 34.  
 —, Larval Anal, in Opisthobranch Gastropods, 19.  
 — of Branchiomma, Structure of, 219.  
 — of Crangon, Methods of Studying Development of, 148.  
 Eye-pieces, Powers of, 501.  
 — — — See Contents, xxxiii.  
 —shades, 488.  
 Eyes in Scorpions, 411.  
 — of Arthropods, 209, 938.  
 — of Cymothoidæ, 730.  
 — of Diptera, 31.  
 —, So-called, of Tridacna, 564.  
 Eylmann, E., European Daphniidæ, 949.  
 Eyre, J., Pond Dredging and Collecting, 505.
- F.
- Fabre-Domergue, —, First principles of the Microscope and microscopical technique, 1036.  
 — Researches on Ciliated Infusoria, 751.  
 —, Structure of Urcolaria, 753.  
 Fankhauser, J., Diastase, 997.  
 —, Euglena, 754.  
 Farabœuf's, Robin's and Lacaze-Duthiers' Injecting Syringes, 678.  
 Farre, A., Death of, 170.  
 Fasoldt, C., Test-plates, 298, 817.  
 —, Variation in Micrometric Measurements due to different illumination, 814.  
 Fat-cells, Peculiar, 928.  
 Fatty Matters in Cultivation Media, 504.  
 Fauna of Mosses, 199.  
 Faussek, V., Development of Generative Organs in Arachnida, 946.  
 Feather, Methods of studying typical Birds', 314.  
 Fegatella, Production of Gemmæ by, 92.  
 Feist, A., Protection of Buds, 989.  
 Fell, G. E., Exhibition of "Letter O occupying space of 1/1,000,000 in. magnified 3200 times," 140.  
 Female Crabs, Male Appendages on, 730.  
 Fermentation in Phanerozamia. See Contents, xxvi.  
 Ferments, Spores of, 633.  
 Ferns, Preparation and Mounting of, 665.  
 — See Cryptogamia Vascularia, Contents, xxvi.  
 Ferria, L., Staining of Elastic Fibres with Chromic Acid and Safranin, 1053.  
 Ferry, —, Medico-legal Identification of Blood-stains, 520.  
 Fertile, Conversion of, into Sterile Fronds, 261.  
 Fertilization and Segmentation in *Ascaris megalcephala*, 423.  
 — of *Ascaris megalcephala*, 43, 583, 736.  
 — of *Calopogon parviflorus*, 454.  
 — of *Cattleya labiata*, 994.  
 — of *Euphrasia*, 767.  
 — of Flowers, 82.  
 —, Karyokinesis in its Relation to, 928.  
 Fetterolf, G., and J. A. Ryder, Vestiges of Zonary Decidua in Mouse, 186.  
 Fever, Relapsing, Staining Spirochæte of, 1054.  
 Fewkes, J. W., Are there Deep-sea Medusæ? 236.  
 —, Medusæ from New England, 592.  
 —, New Mode of Life among Medusæ, 591.  
 —, New Physophore, 592.  
 —, Preparation of Embryos of *Asterias*, 1045.  
 —, Sucker on Fin of *Pterotrachea*, 205.  
 Fibres, Elastic Staining of, with Chromatic Acid and Safranin, 1053.  
 Fibrillaria and Ceratomyces, 630.  
 Fibrin and Micro-organisms, New Method for Staining, 675.  
 Fibro-vascular Bundles in Pinguicula, Arrangement of, 74.  
 — — — in the Petiole, Distribution of, 74.  
 — — — System, Foliar, importance of, in Vegetable Anatomy, 985.  
 Fibrosin, A new cell-content, 246.  
 Fick, R., Inosite, 72.  
 Fiedler, K., Development of Generative Products in *Spongilla*, 64.  
 —, Formation of Ova and Spermatozoa in *Spongilla fluviatilis*, 966.  
 —, Investigation of Generative Products of *Spongilla*, 1045.  
 Fielde, A. M., Dorsal Appendages, 570.

- Fiji, New Species of *Biddulphia* from, 466.  
 Films, Measuring Thin, 501.  
 Filter-capsule, Steinach's, 850.  
 Fin of Pterotrachea, Sucker on, 205.  
 Fine-adjustment by tilting the Stage, 478.  
 ———, Griffith's, 1022.  
 ———, Pritchard's Microscope with "Continental," 1022.  
 Finland, Fungi of, 275.  
 Fire-proof Cotton-wool Plug for Test-tubes, 1040.  
 Fir, Scotch, "Rouge" of, 781.  
 Fisch, C., and M. Reess, Elaphomyces, 273.  
 Fischer, A., Albuminous reaction of Cell-wall, 602.  
 ———, Bacterial Growth at 0° C., 1014.  
 ———, Glucose as a Reserve-material in Woody Plants, 984.  
 ———, B., Phosphorescent Bacillus, 277.  
 ———, E., Stretching of the Receptacle of the Phalloidei, 629.  
 ———, P., Actiniae of Coasts of France, 593.  
 ———, Photographing Phosphorescent Bacilli by means of their own light, 813.  
 ———, Scyphistomata of *Acraspedote Medusae*, 965.  
 Fischl, R., (a) A new process for making Microscopic preparations from test-tube cultures; (b) the preparation of threads effectively impregnated with micro-organisms, 311, 833.  
 Fishes, Bony, Origin and Significance of the so-called free Nuclei in the Nutrient Yolk of, 706.  
 Fixation, Note on, and New Nuclear Stain, 675.  
 Fixing Sections, 159.  
 Flabellum, 963.  
 ———, Growth of, 237.  
 Flagellata, &c., Chemotactic Movements of, 770.  
 ———, Method of Preparing Tegumentary Filaments of, 832.  
 Flahault, C., and E. Bornet, Filamentous Heterocystous Nostochineae, 472.  
 ———, New Genera of Perforating Algae, 776.  
 Flea, To prepare Head of, 511.  
 Fleischl Hæmometer, 808.  
 Fleischmann, A., Absorption of Water by Molluscs, 563.  
 ———, Development of Egg of *Echinocardium cordatum*, 590.  
 Fleming (N.) on the Cell, 553.  
 ———, W., Preparing Testicle for observing Nuclear Fission, 146.  
 ———, Spermatogenesis of Salamander, 189.  
 ———, Staining with Rosanilin Nitrate in watery Glycerin Solution, 518.  
 Flesch, M., Beck's Microsyringe, 849.  
 ———, Micro-chemistry of Nerve-cells, 712.  
 ———, On the influence of the modern improvements on Microscopes for medical men, 1036.  
 1888.  
 Flesch, M., Preparation of Brains and other Organs, 507.  
 ———, Staining Living Preparations, 515.  
 Fletcher, J. J., New Australian Earth-worms, 420.  
 Flies, Dissemination of Bacillus by, 635.  
 ——— tongues, mounting, 511.  
 Floral Axis, Anatomy of, 254.  
 ——— Nectary of *Symphoricarpus*, 255.  
 Floridea, New Fresh-water, 93.  
 ———, New Genera of, 1002.  
 Flos-aquæ, Remarkable, 633.  
 Floscularia annulata, 231.  
 Flot, L., Aerial Stems, 451.  
 Flower, Comparative Morphology of, 451.  
 ——— of Cruciferae, Diagram of, 611.  
 Flowering of *Euryale ferox*, 83.  
 Flowers and Fruit of Sparganium and Typha, 78.  
 ———, Comparative Anatomy of, 255.  
 ———, Development of, in the Bud, 610.  
 ———, Fertilization of, 82.  
 ———, Inconspicuous, Effect of Cross-fertilization on, 612.  
 ——— of *Canna*, Morphology of, 611.  
 ———, Physiological Organography of, 256.  
 ———, Size and Colour of Alpine, 452.  
 Fluorescence of Chlorophyll, 245.  
 Fly, Early Stages in Development of Egg of, 573.  
 Foà, F., Structure of Red Blood-corpuscles, 198.  
 Focke, W. O., Dichotypy, 78.  
 Focus, Depth of, 652.  
 Focusing Arrangement, Jeserich's, 1031.  
 ———, Neuhaus's, 809.  
 ———, Plössl's, 651.  
 ——— Screen, Nelson's Photomicrographic, 119.  
 ———, Stenglein's Coarse and Fine, 1032.  
 Foerste, A. G., Cross-fertilization, 993.  
 Foettinger, A., Anatomy of *Pedicellina*, 208.  
 Fol, H., Collin's Automatic Cannula-holder, 680.  
 ———, Distribution of Striped Muscle, 714.  
 ———, Microscopic Structure of Muscles of Molluscs, 199.  
 Foliar Fibrovascular System, Importance of, in Vegetable Anatomy, 985.  
 ——— Sheath of the *Salicornieae*, 609.  
 Folliculina ampulla, 598.  
 Food Constituents, Supply of, at Different Periods of the Growth of Plants, 614.  
 Food-material, Organs for the absorption of vegetable, by plants containing chlorophyll, 249.  
 ———, Nutrient, of Bees, 942.  
 Foot, Heteropod, Morphology of, 24.  
 Foraminifer, New, 437.  
 Foraminifera, Carboniferous, Additions to the Knowledge of, 533.  
 ———, Isolating, 664.

- Foraminifera, Nature of Opaque Scarlet Spherules found in many Fossilized, 438.  
 —, New, 598.  
 —, of the Red Chalk, 383.  
 —, Primitive Resemblance of Ovarian Ova and, 700.  
 —, Relationships of, 66.  
 —, Sherborn's Bibliography of, 757.  
 Foreign and American Microscopes, 797.  
 —; the Verdict of an Impartial Expert, 798.  
 Forel, A., Lenses of Ants, 571.  
 Formic Acid, Secretion of Pure Aqueous, by Lepidopterous Larvæ for the Purposes of Defence, 405.  
 Formica rufa, Sense of Direction in, 212.  
 Formose, Action of, on Cells Destitute of Starch, 85.  
 Forssell, K. B. J., Glæolichenes, 95.  
 Fossil Botany, Solms-Laubach's Introduction to, 620.  
 — Plants, Anomalous cells in the interior of the tissue of, 605.  
 Foster, M., B. Sanderson, and L. Brunton, Manual of the Physiological Laboratory, 686.  
 Fowler, G. H., Anatomy of Madreporaria, 434.  
 —, New Pennatula from the Bahamas, 593.  
 —, and A. M. Marshall, 'Porcupine' Pennatulida, 745.  
 Fowls, Gape Worm of, 740.  
 Fraipont, J., Polygordius, 225.  
 —, Preparing Polygordius, 662.  
 France, Actiniæ of Coasts of, 593.  
 Frank, B., Formation of Nitric Acid in Plants, 616.  
 —, New Forms of Mycorrhiza, 268.  
 —, Root-symbiosis in the Ericaceæ, 86.  
 Frankel, C., Cultivation of Anaerobic Micro-organisms, 824.  
 Frankland, G. C., and P. F., New and Typical Micro-organisms from Water and Soil, 789.  
 Frazer, A., Cathcart's Improved Microtome, 1018.  
 Frechou, —, Formation of the Asci in Physalospora Bidwellii, 629.  
 Freeborn, G. C., Notices of New Methods for Staining, 320, 519, 667, 855.  
 Fresh-water Algæ (including Chlorophyllous Protophyta) of the English Lake District II. With description of a new genus and five new species, I, 171.  
 ————— of the United States, Wolle's, 94.  
 —————, Preparation of, 1046.  
 ————— Bryozoa, 27.  
 —————, Nervous System of Phylactolematus, 402.  
 ————— Crabs of Africa, 415.  
 ————— Dendrocœla, Embryogeny of, 586.  
 ————— Floridea, New, 93.  
 Fresh-water Infusoria, New, 65.  
 ————— of the United States, 598.  
 ————— Plants, Deposition of Calcareous Incrustations on, 773.  
 ————— Polyzoa, 566.  
 ————— Sponges, 63, 748.  
 —————, Collecting, Growing, and Examining, 305.  
 Freudenreich, E., Preparing Agar-agar, 656.  
 Fricken, v. Respiration of Hydrophilus, 212.  
 Friedländer, B., Creeping Movements of Earthworm, 952.  
 Fritsch, G., 822.  
 —, Billharzia, 588.  
 Frog, Development of, 925.  
 —, Irritability of Spermatozoa of, 707.  
 —, Ovum, Axis of, 15.  
 Frog-tadpole, Infection of, by Saprolegnia ferax, 272.  
 Frommann, C., Properties and Changes of the Membrane, Protoplasm, and Nucleus of Plant-cells, 980.  
 Fructification, Abnormal, of Agaricus procerus, 269.  
 Fruit and Flowers of Sparganium and Typha, 78.  
 — of Borraginæ, 255.  
 — of Solanaceæ, 611.  
 — of Umbelliferæ, Development of, 79.  
 — trees, Fungi of, 780.  
 Fruits and Leaves, Colours of, 254.  
 — and Seeds, Motion of Rotating Winged, 612.  
 — of Rhamnus, 78.  
 —, Explosive, of Alstroemeria, 255.  
 —, masked, 79.  
 —, Overlooked Function of many, 992.  
 Fucus, Apical Cell of, 621.  
 Fumariaceæ, Tubular Cell of, 73.  
 Fungi. See Contents, xxix.  
 — Spores and Bacteria, Demonstrating and counting of, in air, 1059.  
 Fürst, C. M., Spermatogenesis of Marsupials, 386.  
 Fusari, R., Segmentation of Teleostean Ova, 191.  
 Fusoma, 1009.
- G.
- Gage, H., Determination of the Number of Trichinæ or other Animal Parasites in Meat, 164.  
 —, S. H., Starch Injection-mass, 1056.  
 Galileo's Microscopes, 639.  
 Galippe, V., and H. Beauregard, Practical Guide to Microscopy, &c., 323.  
 Galland-Mason's (R.) Microphotoscope, 281.  
 Galtier, V., Chromo-aromatic Microbe, 634.  
 —, —, Pathogenic chromo-aromatic Microbe, 1017.

- Gamasidæ. Anatomy of, 729.  
 Gammarus, Development of, 949.  
 Ganglia, Supra-oesophageal, in Snails, Effects of Lesions of, 717.  
 —, —, of Crab, Effects of Lesions of, 730.  
 Ganglion-cells of the Spinal Cord, Effect of Hardening Agents on, 831.  
 Ganz's (J.) Pinakoscope with Dreyfus's Reflector, 796.  
 Gape Worm of Fowls, 740.  
 Garbini (A.) Closed Water-bath, 1058.  
 — Double Stain with Anilin-blue and Safranin, Modification of, 1054.  
 —, Preparation of Cypridinæ, 508.  
 —, Structure of Cypridina, 36.  
 —, G., Mounting of specimens to be examined with homogeneous-immersion lenses, 1057.  
 Garcin, A. G., Euglena, 972.  
 —, Fruit of Solanaceæ, 611.  
 Gardiner, W., Contractility of the Protoplasm of certain Cells, 457, 614.  
 Gariel, C. M., Practical Treatise on Physical Manipulation, &c., 819.  
 Garnault, P., Anatomy and Histology of *Cyclostoma elegans*, 716.  
 —, Anatomy of *Valvata piscinalis*, 718.  
 —, Reproductive Organs and Oogenesis of *Helix*, 398.  
 —, Structure and Development of Egg in *Chitonidæ*, 933.  
 Gas and Moist Chambers, 287, 288, 289, 290, 291.  
 — Burner, On the Auer Incandescent, 495.  
 Gases, Permeability of the Epidermis of Leaves to, 448, 763.  
 Gasperini, G., New Disease of Lemons, 98.  
 —, Polymorphism of the *Hyphomycetes*, 468.  
 Gasterolichenes, 95.  
 Gastropoda, Preparing Radulæ of Small Species of, 507.  
 — See Contents, x.  
 Gastropods, &c., Ingestion of Water, 199.  
 Gastrula of Amphibians, 549.  
 Gazagnaire, J., Phosphorescence in *Myriopoda*, 945.  
 Grey, F., *Ulothrix*, 465.  
 Gehrke, O., Germination of Palms, 257.  
 Gehuchten, A. v., Striped Muscle of Arthropods, 941.  
 Geissler's Culture Tubes, 287.  
 Gelatin and Agar, Preparation of Nutrient, 825.  
 — Culture Test for Micro-organisms of Water, 855.  
 — Plates, Cooler for quickly setting, 828.  
 Gelatinous Envelope and Cell-membrane of *Desmidiæ*, 1004.  
 Gelsomineæ (*Jasminæ*), Endosperm of, 249.  
 Gemmæ in *Trichomanes*, Formation of, 262.  
 —, Production of, by *Fegatella*, 92.  
 Gemmation in *Linckia multipora*, 431.  
 Gemmules of *Silicispongia*, 596.  
 Generative Apparatus of *Diplozoon paradoxum*, 427.  
 — Organs, Development of, in *Arachnida*, 946.  
 — — of *Cestoda*, Development of, 426.  
 — Products in *Spongilla*, Development of, 64, 1045.  
 — — of *Spongilla*, Investigation of, 1045.  
 Genital Products in *Oligochaeta*, Homology of Segmental Organs and Efferent Ducts of, 419.  
 Geotropism, 458.  
 —, Case of Abolition of, 996.  
 —, Method of Studying, 770.  
 Geraniaceæ, Comparative Anatomy of, 75.  
 —, Sub-epidermal Network of the Root of, 986.  
 Gerlach, L., Embryoscope, 491.  
 —, Experimental Embryology, 16.  
 Germ-bands of *Lumbricus*, 38.  
 — -cells, Wandering Primordial, in *Echinoderms*, 56.  
 — -layers of *Clepsine*, 37.  
 — -stripe of Insects, Primary Segmentation, of, 941.  
 German *Lepidoptera*, Scent-organs of, 406.  
 — *Sphagnaceæ*, 621.  
 Germany, Sydow's Lichens of, 621.  
 Germinal Layers in *Cephalopods*, 931.  
 — — in *Teleostei*, 189.  
 — — in the Shrew, Inversion of, 706.  
 — — of *Cephalopods*, Homology of, 396.  
 — — of *Meloe*, 942.  
 Germination of *Phanerogamia*. See Contents, xxiv.  
 Germs in fluids, On the quantitative determination of, 686.  
 Giard, A., Parasitic Castration in the *Eucyphotes* of *Palæmon* and *Hippolyte*, 414.  
 —, *Photodrilus phosphoreus*, Type of a New Genus of Phosphorescent *Lumbricids*, 39.  
 —, Symbiotic Fungus in *Molgulidæ*, 782.  
 — and J. Bonnier, New Species of *Ceponinæ*, 731.  
 — —, The *Bopyridæ*, 216.  
 — —, Two new Genera of *Epicardia*, 217.  
 Giaxa, --- de, Simple Method for reproducing Koch's Cultivation Plates, 827.  
 Gibson, G., Odoriferous Glands of *Blaps*, 943.  
 —, Spermatogenesis of Arthropods, 940.

- Gieson, J. v., 834.  
 —, The Brain-cortex stained by Golgi's method, 849.  
 Gifford, J. W., Apochromatic Objectives, 287.  
 —, Preparations for High Powers, 834.  
 Gigantic Cephalopoda, 930.  
 Gilbert, J. H., and J. B. Lawes, Sources of the Nitrogen of Vegetation, 261.  
 Glairine and Baregine, Physiological experiments on Organisms of, 1019.  
 Gland, Green, of Crayfish, 26.  
 —, Mucous, of Urochæta, 422.  
 Glanders, Spore-formation in the Bacillus of, 473.  
 Glands, Epidermal, 81.  
 —, Odoriferous, of Blaps, 943.  
 —, Salivary, of Insects, 211.  
 —, —, of Leech, 38.  
 —, Salt-excreting, of Tamariscinæ, 249.  
 Glandular Epithelium of Kidney of Prosobranch Gastropods, Comparative History of, 715.  
 Glass, "New, just made in Sweden," 499.  
 —, The Jena Optical, 486.  
 Globig, —, Bacterial Growth between 50° and 70° C., 824.  
 Gloeocapsa polydermatica, Symbiosis of Bacteria with, 634.  
 Gloeolichenes, 95.  
 Glucose as a Reserve-material in Woody Plants, 984.  
 Glycerin, Isotonic Coefficient of, 617.  
 — Solution, Staining with Rosanilin Nitrate in watery, 518.  
 Glycogen, Accumulation and Consumption of, by Fungi, 96.  
 Goblet-cells of Intestine of Salamander, 712.  
 Godlewski, E., Irritability of Growing Parts of Plants, 615.  
 Goebel, K., Conversion of Fertile into Sterile Fronds, 261.  
 —, Epiphytic Jungermannicæ, 92.  
 —, Germination of Ferns, 89.  
 —, Heterophyllous Ferns, 90.  
 Goethe, R., Torsion of Stems, 989.  
 Goette, A., Development of Petromyzon fluviatilis, 549.  
 Gold, Chloride of, Staining Nerve-terminations with, 155, 673, 674.  
 — — — and Osmic Acid Methods, 846.  
 Goldman, F., Critical studies on the methods of determining the presence of starch in plants, especially in grain-plants, 324.  
 Golfarelli's (J.) Micrometric Microscope for Horologists, 103.  
 Gomont, M., Cellular Envelope of the Filamentous Noctacææ, 632, 1012.  
 —, Relationship between Phormidium and Lyngbya, 784.  
 Gonactinia prolifera, 503.  
 Gonidia of Gymnosporangium, 1010.  
 Gonococci, Roux's Colour-test for the detection of, 517.  
 Gordiaceæ, Structure and Position of, 737.  
 Gordii, Development and Specific Determination, 228.  
 Gordiidae, Studies on, 583.  
 Gordius, Life-history of, 228.  
 Gorgonidae of Naples, 435.  
 Gosse, P. H., Obituary, 822, 1061.  
 Gourret, P., and P. Roeser, Protozoa of Corsica, 755.  
 Graber, —, v., Apparatus for determining Sensibility to Heat, 114.  
 —, Polypody of Insect Embryos, 568.  
 —, Primary Segmentation of the Germ-stripe of Insect s, 941.  
 —, Thermic Experiments on Periplaneta orientalis, 31.  
 Gracilaria, Procarp and Cystocarp of, 622.  
 Graff, L. v., Annelid Genus Spinther, 42.  
 Granel, —, Origin of the Suckers in Phnacrogamous Parasites, 80.  
 Grape-disease—Comothyrium diplodiella, 98.  
 Grapes, "Edelfäule" of, 1009.  
 Grasses, Ovules of, 611.  
 Grassi, B., Parasitic Protozoa, 974.  
 —, Primitive Insects, 29.  
 —, Protozoa Parasitic in Man, 240.  
 —, Tenia nana, 46.  
 — and S. Calandruccio, Echinorhynchus parasitic in Man, and whose intermediary host is a Blaps, 739.  
 — and W. Schewiakoff, Megastoma entericum, 599.  
 Gray, A., Obituary, 822.  
 —, W. M., Double-staining of Nucleated Blood-corpuscles, 673, 842.  
 —, Photomicrography, 813.  
 Greff, L. v., 'Challenger' Myzostomida, 590.  
 Green, J. R., Germination of the Tuber of the Jerusalem Artichoke, 613.  
 Green Gland of Crayfish, 216.  
 Greenwood, M., Digestion in Rhizopods, 240.  
 Gregarine, New, 976.  
 Gregg, W. H., Anomalous Thickening in the Roots of Cycas, 75.  
 Greinert, M. Morphology and Anatomy of Loasacææ, 453.  
 Grevillius, A. Y., Mechanical system of Pendent Organs, 75.  
 Grieg, J. A., Norse Aleyonaria, 239.  
 Griesbach, H., Metanil-yellow, 677.  
 —, Theory of Microscopical Staining, 1056.  
 Griffith (E. H.), Club Microscope, 1062.  
 —, Fine-adjustment, 1022.  
 —, Photomicrographic Camera, 1031.  
 Griffiths, A. B., Problematical Organs of the Invertebrata, 714.  
 —, Renal Organs of Star-fishes, 958.  
 — Salivary Glands of Sepia officinalis and Patella vulgata, 932.

- Griffiths, A. B., and Mrs. —, Influence of certain Rays of the Solar Spectrum on Root-absorption and on the Growth of Plants, 769.
- , G. C., Colour-relation between Pupæ and surroundings, 727.
- Grigorjew, A. W., Specificness of the Tubercle Bacillus Stain, 157.
- Grobben, C., Morphology of the Heteropod Foot, 24.
- , Pericardial Gland in Lamellibranchs, 720.
- Groom, T. T., New Features in *Pelanechinus corallinus*, 233.
- Grosse, W., On polarizing prisms, 1029.
- Grove, E., and G. Sturt, Fossil Marine Diatoms from New Zealand, 94.
- Groves, W. B., *Pimina*, a new Genus of Hyphomycetes, 780.
- “Growing Slide,” Modification of Pagan’s 1028.
- Growth of Phanerogamia. See Contents, xxv.
- Gruber, A., Multinuclear Infusoria, 597, 750.
- , New Rhizopods, 757.
- , Notes on Protozoa, 969.
- Guepinia and Ombrophila, 1008.
- Guerne, J. de, Asplanchnidae, 740.
- , and E. Chevreux, New Commensal Amphipod, 416.
- , and J. Richard, Geographical Distribution of *Diaptomus*, 731.
- Guinea-pig, Spermatogenesis in, 707.
- Gütel, F., Egg-shell of *Lepadogaster*, 550.
- Gulliver, G., Note on the Minute Structure of *Pelomyxa palustris*, 11, 171.
- Gum-arabic, Substance of which it is formed, 984.
- Gundlach, E., Apochromatic Objectives, 285.
- Günther, —, The quickest Method for Staining Tubercle bacilli, 849.
- Gymnosporangium, Gonidia of, 1010.
- H.
- Haacke, W., Nature of Polyparium, 594.
- Haberlandt, G., New Method for Marking Root-hairs and for Hardening and Staining Plant-cells, 1045.
- Habits and Age of American Tarantula, 215.
- Haddon, A. C., Larval Actiniæ parasitic on *Hydromedusa*, 965.
- Haeckel, E., *Radiolaria*, 437.
- , System of Siphonophora, 741.
- Hæmatoxylin, Alcoholic Solution of, 846.
- Copper, Benda’s Modified, 158.
- Method, Weigert’s, as applied to other than Nervous Tissues, 674.
- Hæmochromometer, Improved, 494.
- Hæmoglobin Crystals of Rodents’ Blood, 198.
- Hæmometer, On the *Fleischl*, 808.
- Haensch, —, and Schmidt, —, The new improved enlarging camera of, 1034.
- — —, Zirconium Light for Photomicrography, 1033.
- Haensell, P., Method of Imbedding the Eye in Paraffin and Celloidin, 515.
- Hailstones, Bacteria in, 277.
- Hairs, Trigger-, of the Thistle-flower, 452.
- Half-clearing method of preparing Nerve Sections, 680.
- Haliotis, Abnormal Growth in, 561.
- Hallez, P., Embryogeny of Fresh-water *Dendrocoela*, 586.
- Halliburton, W. D., Hæmoglobin Crystals of Rodents’ Blood, 198.
- , Methæmoglobin Crystals, 506.
- Hällstén’s (K.) “Compressorium,” 489.
- Halsted, B. D., Three Nuclei in Pollen-grains, 440.
- , Trigger-hairs of the Thistle-flower, 452.
- Hamann, O., Histology of Echinoderms, 53, 149.
- , Morphology of Ophiurids, 432.
- , Preparation of Echinodermata, 510.
- , Wandering Primordial Germ-cells in Echinoderms, 56.
- Hamilton, D. J., Method of combining Weigert’s Hæmatoxylin-copper Stain for Nerve-fibre with the use of the Freezing Microtome, 159, 1051.
- Handlirsch, A., Sand-wasps, 30.
- Hanitsch, R., Anatomy and Histology of *Limax agrestis*, 716.
- Hansen, A., Function of the Colouring Matter of Chlorophyll, 997.
- , E. C., Analysis of Water used for Brewing as regards Micro-organisms, 685.
- Moist Chamber, 290.
- , Pure culture of yeast, 830.
- Hansgirk, A., Aerophytic Species of *Ultrichaceæ*, 1002.
- , Alga-flora of Bohemia, 626.
- , Algological Studies, 267.
- , *Bacillus muralis*, 277, 787.
- , Cellar Bacteria, 1014.
- , Classification of *Confervoideæ*, 775.
- , *Trochiscia* and *Tetraedron*, 1013.
- Hansgirkia, a genus of aerial Alga, 1003.
- Haplococcus reticulatus*, 782.
- Haplodiscus piger*, 955.
- Harchek, A., Optometer and apparatus for measuring the foci of, and centering optical lenses, 819.
- Hardening Agents, Effect of, on the Ganglion-cells of the Spinal Cord, 831.
- Medium for the Brain, Sublimate as a, 831.
- Hardy’s (J. D.) Growing Slide, 489.
- Harless’ Gas Chamber, 288.
- Harmer, S. F., Embryogeny of *Ectoproctus Bryozoa*, 721.
- Harris and Power, Manual for the Physiological Laboratory, 166.

- Hartig, R., *Trichosphæra paradoxa* and *Herpotrichia nigra*, 470.
- Hartlaub, C., *Cladonemide*, 235.
- Hartnack's new Objective, 646.
- Hartog, M., Recent Researches on the Saprolegniææ, 1010.
- , True Nature of the Madreporic System of Echinodermata, 57.
- Harz, C. O., *Oidium Fragariæ*, 274.
- Haseloff, B., Crystalline Style, 566.
- Hasselberg, B., On the method of determining with great accuracy the focal length of a system of lenses for different rays, 1035.
- Haskell, W. A., Development of Emu, 187.
- , Embryology of *Vermilia caespitosa* and *Eupomatus elegans*, 578.
- , *Tennocephala*, 50.
- Hatschek, B., Significance of Sexual Reproduction, 193.
- Hauck, F., *Choristocarpus tenellus*, 93.
- and Richter's *Phycotheca universalis*, 627.
- Hauptfleisch, P., Cell-membrane and Gelatinous Envelope of Desmidiææ, 1004.
- Hauser, G., Sarcina of the Lungs, 634.
- , Staining Spores, 845.
- Haushalter, —, and Spillmann, —, Dissemination of *Bacillus* by Flies, 635.
- Hauatoria of the Rhinanthææ and Santalacææ, 250.
- Hay Infusion, Two kinds of *Vibrios* found in decomposing, 100.
- Hayward, R. B., Micromillimetre, 503.
- Heart of Pulmonate Mollusca, Development of, 204.
- Heat, Apparatus for determining Sensibility to, 114.
- , Influence of Radiant, on the Development of the Flower, 995.
- Heathcote, F. G., Post-embryonic Development of *Julus terrestris*, 213, 727.
- Heather's (J. F.) "Mathematical Instruments," 501.
- Heckel, E., Formation of two fertile hymenia in *Polyporus applanatus*, 629.
- , and F. Schlagdenhauffen, Laticiferous product of *Mimusops* and *Paysona*, 759.
- Heckert, G., Natural History of *Leucochloridium paradoxum*, 49.
- Hegelmair, F., Formation of Endosperm in Dicotyledons, 765.
- Hegetschweijer, —, and Stizenberger, —, Lichens on unusual substrata, 96.
- Heidenhain's Gas Chamber, 288.
- Heimerl, A., *Nyctagineæ*, 82.
- Heinrich, E., Congo-red as a Reagent for Cellulose, 1053.
- , Structure of *Impatiens*, 764.
- , Tubular Cells of the *Fumariacææ*, 73.
- Helix, Reproductive Organs and Oogenesis of, 398.
- Helix Waltoni*, Development of, 24.
- Helriegel, —, and Willfarth, —, Absorption of Nitrogen by Plants, 770.
- Henking, H., Early Stages in Development of Egg of Fly, 573.
- Henning, E., Latrality in *Conifereæ*, 78.
- Henrici, J. F., Recently-discovered Microscopes of historic interest, 485.
- Hen's Egg, Trematode in white of newly-laid, 51.
- Henslow, G., Comparative Anatomy of Flowers, 255.
- , Transpiration as a Function of Living Protoplasm, 456.
- Hensoldt, H., The Microscopical Investigation of Rocks, 855.
- (M.) Reading Microscopes, 640.
- Hepaticææ, Antherozoids of, 461.
- , Distribution of, 264.
- Herdman, W. A., Reproductive Organs of *Aleyonidium gelatinosum*, 208.
- Heredity, 926.
- and Karyokinesis, 554.
- , Principle of, and the Laws of Mechanics applied to the Morphology of Solitary Cells, 926.
- Hernia, Cabbage, 273.
- Hero, Systematic Position of, 718.
- Hérouard, E., Calcareous Corpuscles of Holothurians, 58.
- Herpotrichia nigra* and *Trichosphæra paradoxa*, 470.
- Herrick, F. H., Abbreviated Metamorphosis of *Alpheus*, and its Relation to the Condition of Life, 414.
- , Development of *Alpheus*, 577.
- Hertwig's (O.) Human and Vertebrate Embryology, 710.
- Hertwig, R., Supplementary Report on 'Challenger' *Actinaria*, 965.
- Herxheimer, K., Staining the Elastic Fibres of the Skin, 155.
- Hesse, W., On the quantitative determination of germs in fluids, 686, 856.
- Heterobasidial Basidiomycetes, 1006.
- Heterodera Schachtii, 953.
- , Integument of, 738.
- , Structure and Development of, 737.
- Heterophylly, 253.
- Heteropod Foot, Morphology of, 24.
- Heteropoda and Pteropoda, Musculature of, 560.
- Heterostylism and Self-fertilization, 453.
- Heurck, H. v., The new apochromatic objectives of Herr Reichert, 1025.
- , Watson and Sons' Anglo-Continental or Student's Microscope, 797.
- Hevea and Manihot, Laticiferous System of, 72.
- Hexactinellida, 'Challenger,' 597, 747.
- Heymann, J. F., Nerve-endings in the Leech, 952.
- Hick, T., Physiology of *Phæophyceææ*, 462.

- Hickson, S. J., Sex-cells and Development of *Millepora*, 236.
- , Sexual Cells and Early Stages in Development of *Millepora plicata*, 964.
- Hildebrand, F., Germination of *Oxalis rubella*, 613.
- , Production of Vegetative from Fertile Shoots of *Opuntia*, 768.
- Hildebrandt, H., Comparative Anatomy of *Ambrosiaceæ* and *Senecioideæ*, 449.
- Hilgendorf's (F.) Auxanograph, 646.
- Hilger, C., and F. Blochmann, *Gonactinia prolifera*, 593.
- Hillhouse, W., Function of Tannin, 444.
- Hinde, G. J., New Species of Uruguay, 748.
- Hippolyte and Palæmon, Parasitic Castration in the Eucyphotes of, 414.
- Hirudinea, External Morphology of, 950.
- , Vascular System of, 219.
- His, W., and H. Strasser. On the Methods of Plastic Reconstruction and their importance for Anatomy and Embryology, 686.
- Histology. See Contents, ix.
- Hitchock, R., May's Apparatus for marking Objects, 113.
- , Reminiscences and notes on recent progress, 140.
- , The Biological Examination of Water, 166.
- Hobbs, W. H., On the use of Microscope in Petrography, 523.
- Hochstetter, F., Modification of Schiefferdecker's Celloidin Corrosion Mass, 159.
- Hodgkinson, A., On the Diffraction of Microscopic Objects in Relation to the Resolving Power of Objectives, 501.
- Hofer, B., Salivary Glands of Cockroach, 725.
- Hoffmann, C. K., Origin and Significance of the so-called free Nuclei in the Nutrient Yolk of Bony Fishes, 706.
- Höhnel, F. v., Substance of which Gum-arabic is formed, 984.
- Holman's Current Slide, 806.
- Holostomum, 954.
- Holothurians. Calcareous Corpuscles of, 58.
- , New and Old, 591.
- Homogeneous Paraffin, 151.
- Hood, J., *Floscularia annulata*, 231.
- Hornodendron and *Stysanus*, 1010.
- Hornbeam and Birch, Spring-sap in, 445.
- Hornberger, R., Spring-sap in the Birch and Hornbeam, 445.
- Horologists, Gofarelli's Micrometric Microscope for, 103.
- Horst, R., Cardiac Body of Annelids, 418.
- Hot-plate Apparatus, 681.
- stage, Babes', 800.
- water Circulation Stage, Schäfer's 649.
- Houssay, F., and —, Bataillon, Development of the Axolotl, 707.
- Houzeau, J. C., Microscope and Telescope, 820.
- Hovelacque, M., Development and Structure of *Orobanche* in a young stage, and of its suckers, 80.
- , Propagula of *Pinguicula*, 764.
- How to work with the Microscope, 324.
- Howchin, W., Additions to the Knowledge of the Carboniferous Foraminifera, 533.
- Hoyer, H., Injection-mass for the Vessels of the Spleen, 848.
- Hoyle, W. E., General Sketch of the Trematoda, 953.
- Hubrecht, A. A. W., 'Challenger' Nematode, 52.
- Hudson (C. T.) Illustrations of Pond Life, 855.
- Hueppe, F., Assimilation in Plants destitute of Chlorophyll, 455.
- , Eggs for Cultivation purposes, 827.
- Huizinga's Gas-chamber, 288.
- Human Distomum, New, 49.
- Embryos, Two Young, 16.
- Ovum, 547.
- Humboldtia laurifolia as a Myrmecophilous Plant, 83.
- Hungary, Fossil Diatoms of, 466.
- Hunger, E. H., Viviparous Plants and Apogamy, 768.
- Huth, E., Clinging Plants, 253.
- Hvass, T., On new staining methods in the histological study of nerve-tissue, 519.
- Hy, —, Microchete, 99.
- Hyaloplasm, Nuclear Origin of, 440.
- Hybrid Mosses, 264.
- Hydra, 236.
- Hydridae, Development of, 963.
- Hydroids, New Method of Multiplication in, 433.
- Hydromedusæ, Larval Actinæ parasitic on, 965.
- Hydrophilus, Respiration of, 212.
- Hydrurus, Development of, 623.
- Hygroscopic Movements of the Thallus of *Marchantiæ*, 1001.
- Hymenoptera, Morphology of the Legs of, 725.
- , Poison of, 724.
- Hyphomycetes, *Pimina*, a new Genus of, 780.
- , Polymorphism of, 468.
- Hyrano, K., Seeds of *Pharbitis triloba*, 764.

## I.

- Ide, M., Cell-membrane, 712.
- Ihering, H. v., The *Orthonera*, 400.
- Ijima, J., Some European Tricladæ, 229.
- Illuminating. See Contents, xxxiii.
- Illumination of Objects in Photomicrography, 1033.
- Illuminator, Vertical and Lamp, 650.
- Illustrations of Pond-life, 855.
- to Microscopical Publications, 521.
- Imbedding. See Contents, xxxviii.

- Imhof, O. E., Fauna of Mosses, 199.  
 Immich, E., Development of Stomata, 217.  
 Impatiens, Structure of, 764.  
 Impregnation, Division of the Nucleus, and Cell-division, 600.  
 —, Partial, 709.  
 Incandescant Gas-burner, On the Auer, 495.  
 Incrustation of the Cell-wall of Acetabularia, 463.  
 Indexing Microscopical Slides, 320.  
 Indian Ink, Injection with, 848.  
 Infecting, Apparatus for, 829.  
 Infection of a Frog-tadpole by *Saprolegnia ferax*, 272.  
 Inflorescence, Axis of, 79.  
 Inflorescences and Branches, Anatomy of Annual, 451.  
 Infusoria flagellata, New, from American Fresh Waters, 698.  
 —, Fresh-water, of the United States, 598.  
 —, — — —, of Wellington District, New Zealand, 972.  
 —, Further Observations on Multinuclear, 750.  
 —, Multinucleate, 597.  
 —, New Fresh-water, 65.  
 —, New Parasitic, 436.  
 —, Researches on Ciliated, 751.  
 Infusorian, New Parasitic Ciliated, 971.  
 Inheritance of Acquired Characters, 193.  
 Injecting. See Contents, xxxviii.  
 Innervation of Crabs' Claws, 947.  
 Inosite, 72.  
 Insect relations of *Asclepiadæ*, 82.  
 — Slides, Enock's, 523.  
 Insecta. See Contents, xii.  
 Insects, Section-cutting applied to, 152.  
 Instantaneous Photomicrography, 651, 811.  
 Intercoral Lobe of certain Crayfishes, 577.  
 Intestinal Epithelium of *Ascaris*, 583.  
 — — —, Secreting cells of, 555.  
 Intestine and digestive Glands of Decapods, 729.  
 —, Cleansing the, of many animals of sand, 1044.  
 Intussusception, Growth by, 557.  
 Iodine, Blue Coloration of Fungi by, 628.  
 Iron-bacteria, 786.  
 — Pyrites, Measuring Corrosion Surfaces in, 803.  
*Irpex fusco-violaceus*, Fr., and *Polyporus abietinus*, Fr., Identity of, 468.  
 Irritability of Growing Parts of Plants, 615.  
 — of Spermatozoa of Frog, 707.  
 — of the Stamens of *Echinocactus*, 261.  
 Irritation, Movements of, 259.  
 — — —, of Multicellular Organs, 615.  
 Ishikawa, C., and A. Weismann, Formation of Polar Globules in Animal Ova, 705.  
 — — —, Partial Impregnation, 709.  
 Isoetes, Systematic Position of, 773.  
 Isotonic Coefficient of Glycerin, 617.  
 Israel (O.) and M. Stenglein's Photomicrographic Microscope, 115.  
 Istvánfi, G., Structure of *Ulothrix*, 1003.  
 Italian Microscopical Society, 655.
- J.
- Jackman, W. S., Mounting Tape-worms, 314.  
 Jackson, R. S., Catching fixed forms of Animal life on transparent media for Study, 830.  
 Jacobi, E., Hardening and Staining Plate-cultivations, 848.  
 — Preparation of Nutritive Media, 655.  
 Jacquemin, G., *Saccharomyces ellipsoideus* and its Use in the Preparation of Wine from Barley, 785.  
 Jakimovitch, J., Axis-cylinder and Nerve-cells, 556.  
 Jaksch, R. V., Diagnosis of internal diseases, 1060.  
 James, F. L., Apochromatic Objectives, 286.  
 — Clinical Microscopical Technology, 324.  
 —, Medico-legal Identification of Blood-stains, 524.  
 —, Nobert's Bands, 501.  
 —, Physicians and the Microscope, 523.  
 —, Stain for the Morphological Elements in Urine, 845.  
 —, Teasing-needle, 520.  
 Janczewski, Ed., Germination of *Anemone apennina*, 613.  
 Jännicke, W., Comparative Anatomy of Geraniaceæ, 75.  
 Janosik, J., Histology of the Ovary, 713.  
 —, Two Young Human Embryos, 16.  
 Janse, J. M., Permeability of Protoplasm, 601.  
 —, Plasmolysis of Algae, 93.  
 Japan, Echinoidea of, 431.  
 Jatta, G., Olfactory Ganglia of Cephalopods, 931.  
 Jena Optical Glass, 486.  
 Jensen, O. S., Spermatogenesis, 16.  
 Jerusalem Artichoke, Germination of the Tuber of, 613.  
 Jeserich, P., Photomicrography by the bromo-silver gelatin process, 296.  
 Jeserich's Focusing Arrangement, 1031.  
 — Photomicrographic Apparatus, 1029.  
 Jickeli, C. F., Nervous System of *Echino-dermata*, 741.  
 Joblot's Microscope, 640.  
 Johannsen, W., Localization of Emulsin in Almonds, 247.  
 —, Oxidation process in Plants after death, 88.  
 Johanson, C. J., *Taphrina*, 470.  
 Johnson, T., *Arceuthobium*, 991.  
 —, Procarp and Cystocarp of *Gracilaria*, 622.

- Jordan, K. F., Physiological Organography of Flowers, 256.  
 Joseph, —, Histology of Nerve-fibres, 395.  
 Jost, L., Development of the Flowers of the Mistletoe, 990.  
 —, Respiratory Organs, 76.  
 Jourdain, S., *Machilis maritima*, 408.  
 Jourdain, E., Preparing and Staining Annelida, 662.  
 Joyeux-Laffaie, J., *Delagia Chætopteri*, 936.  
 — — —, Nervous System of *Chætopterus Valencinii*, 225.  
 — — —, New Genus of Bryozoa, 403.  
 Joynton, E., Indian Fibres, 495.  
 Judd, J. W., Microscopy and the Study of Rocks, 820.  
 Juel, O., Anatomy of *Maregraviaceæ*, 419.  
 Julus, Brain of, 408.  
 Jullien, J., *Cristatella mucedo*, 936.  
 —, Movement of Polypides in *Zoœcia* of Bryozoa, 936.  
 — *terrestris*, Post-embryonic Development of, 213, 727.  
 Jumelle, H., Seeds with Two Integuments, 992.  
 Junceæ, Roots and Rootlets in, 251.  
 Jungermannieæ, Epiphytic, 92.
- K.
- Kaczander, J., Relation of Medullary Canal and Primitive Streak, 15.  
 Kaiser's gelatin, Adaptation of, for arranging Microscopic preparations in rows, 680.  
 Kalide, G., Musculature of Heteropoda and Pteropoda, 560.  
 Karsten, G., Production of Gemmæ by *Fegatella*, 92.  
 —, H., Classification and Description of Fungi, 628.  
 Karyokinesis and Heredity, 554.  
 — in its Relation to Fertilization, 928.  
 — in Lepidoptera, 571.  
 — of Euglypha, 66.  
 Karyokinetic Figures, Demonstrating, 516.  
 — — —, Staining, 1050.  
 Kastschenko, N., A short note in reference to my method, 686.  
 Katz, O., Improved Method for Cultivating Micro-organisms on Potatoes, 142.  
 —, Phosphorescent Bacteria from Seawater, 101.  
 Keller, C. C., Isolating Foraminifera, 664.  
 —, Purification of Tolu Balsam for Microscopical Purposes, 681.  
 —, R., Size and Colour of Alpine Flowers, 452.  
 Kellicott, D. S., Pres. Amer. Soc. Micr., Memoir of, 305.  
 —, Presidential Address to the American Society of Microscopists, 1060.  
 Kerber, A., Determination of the principal image-plane, &c., 1036.  
 Kertesz, A., The Anilin stains, 1056.  
 Kessler, H. F., Aphides, 727.  
 Ketel, F., Lemanea, 93.  
 Khawkin, M. W., Principle of Heredity and the Laws of Mechanics applied to the Morphology of Solitary Cells, 926.  
 Kibbler's, —, Photomicrographic Microscope, 529.  
 Kidney Disease and the Microscope, 138.  
 — of Monotocardate Prosobranch Gastropods, 399.  
 — of Prosobranch Gastropods, Comparative Histology of Glandular Epithelium of, 715.  
 Kienitz-Gerloff, F., Gonidia of *Gymnosporangium*, 1010.  
 Killing contractile Animals in a state of extension, Method of, 1044.  
 Kinetic Phenomena of the Egg during Maturation and Fecundation, 546.  
 King, C. M., Indian Fibres, 495.  
 —, J. D., Preparation and Mounting of Ferns, 665.  
 Kingsley, J. S., Development of the Compound Eye of *Crangon*, 34.  
 —, Methods of Studying Development of Eye of *Crangon*, 148.  
 Kitasato, S., *Spirillum concentricum*, a new species from decomposing blood, 278.  
 Kitt, T., On Photomicrographs, 651.  
 Kitton, F., New Species of *Biddulphia* from Fiji, 466.  
 Klaatsch, H., Radial Micrometer, 293.  
 —, Staining of Ossification Preparations, 154.  
 Klausch, P., Leaves of *Bupleurum*, 608.  
 Klebahn, H., *Peridermium Pini*, 1009.  
 —, Zygosporæ of *Conjugatæ*, 1002.  
 Klebs, G., Albumen in the Cell-wall, 69.  
 —, Physiology of the Cell, 758.  
 Klein, L., Contributions to the technique of permanent microscopical preparations, 834.  
 —, Excursion Microscope, 1020.  
 —, Preparation of Fresh-water Algæ, 1046.  
 —, Technique of microscopical permanent preparations, 1047.  
 —, O., Axis of the Inflorescence, 79.  
 Kleinenberg on Development of *Lopodorrhynchus*, 579.  
 Klemensiewicz, R., A culture-chamber for low temperatures, 831.  
 Knösel's Photomicrographs, 296.  
 Knowles, E. L., "Curl" of Peach-leaves, 89.  
 Knüppel, A., Salivary glands of Insects, 211.  
 Koch A., Endospore Bacteria, 1014.  
 —, G. v., *Flabellum*, 963.  
 —, *Gorgonidæ* of Naples, 435.  
 —, L., Biology of *Orobanche*, 85.  
 —, Organs for the absorption of vegetable food-material by plants containing chlorophyll, 249.

- Koch's Cultivation Plates, Simple Method for reproducing, 827.  
 — and Max Wolz's Reflector, 105.
- Koehler, R., Form and Development of Spermatozoa in *Murex*, 200.  
 —, Mode of Investigating Echinorhynchi, 509.  
 —, Structure of Echinorhynchi, 422.
- Kolessnikoff, —, and J. Tarchanoff, Alkaline Egg-albumen as a Medium for Bacteria Cultivation, 503.
- Kolossow, A., Osmic Acid and Gold Chloride Methods, 816.
- Korotneff, A. de, Development of Hydrida, 963.  
 —, Spermatogenesis, 27.  
 —, — in *Aleyonella*, 566.
- Korschelt, E., Egg-membranes of Insects, 722.  
 —, Relation between the Function and Position of the Nucleus, 601.
- Kossel, A., Chemistry of the Nucleus, 390.
- Kotlarewsky, A., Micro-Chemistry of Nerve-cells, 713.  
 —, Preparation of Nerve-cells and Peripheral Ganglia, 505.
- Kowalewsky, N., Action of Methyl-blue on Mammals, 1057.
- Krabbe, G., Formation of Annual Rings in Wood, 75.  
 —, Structure and Growth of the Cell-wall, 441.
- Kräpelin, K., Fresh-water Polyzoa, 566.
- Krašin, F., Retrogression in Oaks, 88.
- Krasser, F., Albuminous reaction of Cell-wall, 602.  
 —, Heterophylly, 253.  
 —, Split Xylem in Clematis, 218.
- Kreusler, U., Assimilation and Expiration of Plants, 768.  
 —, — and Respiration of Plants, 258.
- Kronfeld, M., Apparatus for inclosing microscopical preparations of botanical objects mounted in glycerin, 851.  
 —, Biology of the Mistletoe, 86.  
 —, Double Leaves, 253.  
 —, New Reagent for Albuminoids, 165.
- Krukenberg, C. F. W., Colours of Corals, 60.  
 —, Influence of Salinity, 60.  
 —, Nervous Tracts in Aleyonids, 61.
- Krüß, A., Prism-combinations of calc-spar for mixing and comparing light-pencils, 1029.
- Krysinski, —, Photoxylum for Imbedding, 834.
- Kühne, H., Microscopical Demonstration of Bacteria in Animal Tissues, 315, 856, 1060.  
 —, W., Staining Nerve-endings with Gold Chloride, 673.
- Kühne's Gas Chamber, 288.
- Kükenthal, —, Cleansing the Intestine of many animals of sand, 1044.
- Kükenthal, W., Preparing the Nervous System of Opheliacea, 509.  
 —, Experiments on Earthworms, 580.
- Kulagin, N., Russian Lumbricida, 581.
- Kultschitzky, N., Fertilization of *Ascaris*, 583, 736.  
 —, Methods of Fixing and Preserving Animal Tissues, 510.
- Kündig, J., Development of the Sporangium of Polypodiaceæ, 459.
- Künstler, J., Diplocystis *Schneideri*, 68.  
 —, Method of Preparing Tegumentary Filaments of Flagellata, 832.  
 —, New Foraminifer, 437.  
 —, New Remarkable Worms, 428.  
 —, Technique of Bacteria, 151.  
 —, Vesicular Elements of Protoplasm in Protozoa, 748.
- Kupffer, C., Development of the Lamprey, 708.

## L.

- L., A. S., Differential Screw Slow Motion, 110.  
 —, Inquiry as to the best proportion of Eye-piece to Objective, 487.  
 —, Powers of Eye-pieces, 501.
- Labellum, Sensitive, of *Masdevallia muscosa*, 616.
- Laboulbène, A., Larval Stage of Species of *Ascaris*, 45.
- Lacaze-Duthiers, H. de, Classification of Gastropods, based on the Arrangement of the Nervous System, 401.  
 —, Nervous System of *Aplysia*, 20.  
 —, New Type of Anthozoa, 745.  
 —, Testacella, 562.  
 — and G. Pruvot, Larval Anal Eye in Opisthobranch Gastropods, 19.  
 —, Robin's, and Farabeuf's Injecting Syringes, 678.
- Lachmann, —, Pitcher-like leaflets of *Staphylea pinnata*, 253.
- Lactic Acid, Application of, to the Examination of Algae, 666.
- Lagerheim, G., Application of Lactic Acid to the Examination of Algae, 666.  
 —, Development of Convolvaceæ, 266.  
 —, — of Hydrurus, 623.  
 —, New Pleurocapsa, 784.  
 —, — Puccinia, 782.  
 —, Uronema, a new genus of Chlorozoosporeæ, 626.  
 —, *Stichococcus bacillaris*, 632.
- Labille, F., Central Nervous System of *Tunicata*, 26.
- Lake District, English, Fresh-water Algae of, 1.
- Lamb, D. S., Technique of Frozen Anatomical Sections, 1047.
- Lameere, A., Abnormal Ova of *Ascaris megaloccephala*, 953.
- Lamellibranchiata. See Contents, xi.
- Laminariæ, Sieve-tubes in, 265.
- Lamp and Vertical Illuminator, 650.

- Lamplight or Daylight for Microscopical Observation, 302.
- Lamprey, Development of, 708.
- Lamps for Microscopical Work, 807.
- , magnesium, 494.
- , Schieck's Microscope, 490.
- Lancaster's Gas Chamber, 290.
- Lanice conchilega, Nephridia of, 735.
- Lankester, E. R., Cœlom and Vascular System of Mollusca and Arthropoda, 395.
- Lantern Microscope, The Advantages and Deficiencies of, 646.
- Slides, Making, 305.
- , Photomicrography and the making of, 652.
- Larva of Culex, 212.
- of *Sarcophila Wohlfartii* in Gum of Man, 944.
- Larvæ and Eggs of Teleosteans, 191, 925.
- Larval Anal Eye in Opisthobranch Gastropods, 19.
- Stage of Species of *Ascaris*, 45.
- Lateral Organs, 587.
- of Nemerteans, 51.
- Roots in Monocotyledones, Formation of, 762.
- Latham, V. A., Preparing Sections of Buds, 511.
- , The Microscope and How to Use It, 322, 523, 1060.
- , To prepare the Head of a Flea. Mounting Tongues of Flies, 511.
- Laticiferous product of *Mimusops* and *Payena*, 759.
- System of *Manihot* and *Hevea*, 72.
- Laurent, E., Organic nourishment of Beer-ferment, 785.
- Laurie, M., Organ of *Verrill* in *Loligo*, 932.
- Laux, W., Vascular Bundles in the Rhizome of Monocotyledons, 74.
- Lawes, J. B., and J. H. Gilbert, Sources of the Nitrogen of Vegetation, 261.
- Leach, W., The Lantern Microscope, 646.
- Leaf, Duration of the Apical Growth of, 455.
- of *Dionæa*, Electromotive Properties of, 995.
- of *Mimosa pudica*, Movement of, 457.
- Leaf-fall, Phenomenon analogous to, 88.
- stalk, Anatomy of, 448.
- - —, Growth of, 258.
- - — of *Aralia*, Thickening of the Cell-walls in, 70.
- Leaflets, Pitcher-like, of *Staphylea pin-nata*, 253.
- Leaves and Fruits, Colours of, 254.
- , Double, 253.
- , Evergreen, Reserve-substances in, 983.
- , Formation of Oxalate of Lime in, 444.
- , Influence of Light on the Form and Structure of, 84.
- Leaves, Influence of Light on the Growth of, 614.
- of *Bupleurum*, 608.
- of certain of the Coniferæ, Structure of, 451.
- of Orchideæ, Anatomical Structure of, 608.
- of Polypodiaceæ, 619.
- of *Sigillaria* and *Lepidodendron*, 263.
- of some Coniferæ, Influence of Climate on the Cuticularization and Thickening of, 608.
- , Peach, "Curl" of, 89.
- , Permeability of the Epidermis of, to Gases, 448, 763.
- , Vernation of, 252.
- Leblois, A., Secretory Canals and Secretory Reservoirs, 604.
- Leclerc du Sablon, —, Antherozoids of *Cheilanthes hirta*, 999.
- , — of Hepaticæ, 461.
- , Haustoria of the Rhinanthæ and Santalaceæ, 250.
- , Root-hairs of the Rhinanthæ, 450.
- , *Selaginella lepidophylla*, 620.
- Lecomte, H., Effects produced by the Annular Decortication of Trees, 447.
- Lee, A. B., Spermatogenesis in *Chætognatha*, 227.
- Leech, Nerve-endings in, 952.
- , Salivary Glands of, 38.
- Leeuwenhoek's Discovery of Micro-organisms, 522.
- Legs of Hymenoptera, Morphology of, 725.
- Leguminosæ and Ericaceæ, Super-endo-dermal Network of the Root of, 986.
- , Periderm of, 606.
- , Root-tubercles, of, 251.
- , Tubercles on the Roots of, 608.
- Lehmann, O., Apparatus for Microphysical Investigations, 292.
- , Homology of Segmental Organs and Efferent Ducts of Genital Products in *Oligochæta*, 419.
- , Molecular physics, with special reference to microscopical investigations, 1036.
- , Photomicrography of Chemical Preparations, 293.
- Leidy, J., *Hydra*, 236.
- Leigh's, R., Preserving Blood-corpuscles for Microscopical Examination, 1041.
- Leitgeb, H., Incrustation of the Cell-wall of *Acetabularia*, 463.
- Leitz's Demonstration Microscope, 794.
- small Photomicrographic Apparatus, 650.
- Lemanea, 93, 464.
- Lemoine, V., Brain of *Phylloxera*, 408.
- Lemons, New Disease of, 98.
- Lenhossék's (J. v.) Polymicroscope, 104.
- Lennox, —, Observations on the histology of the Retina by means of the Weigert staining method, 519.
- Lepadogaster, Egg-shell of, 550.

- Lepas, First changes in Fecundated Ovum of, 218.
- Lepidodendron and Sigillaria, Leaves of, 263.
- Lepidoptera, German, Scent-organs of, 406.
- , Karyokinesis in, 571.
- , Nerve-terminations in, 943.
- Lepidopterous Larvæ, Secretion of Pure Aquous Formic Acid by, for the Purposes of Defence, 405.
- Lepra and Tubercle Bacilli, Staining, 157, 846.
- Lernæans and the Philicthydæ, 217.
- Letalle, —, Process of stable staining of amyloid matter by means of eosin and caustic potash, 1057.
- Lettsom, —, Death of, 170.
- Leucchloridium paradoxum, Natural History of, 49.
- Levi, G. B., Venetian Chlorophyceæ, 627.
- Lewin, A., Baumgarten's Method of Triple-staining, 676.
- Lewin, M., Germination of Monocotyledons, 767.
- Lewis's (T. R.) Moist Slide, 291.
- , Collected Papers of, 522.
- Leydig, F., Amœboeytes of Crustacea, 949.
- , Animal Ovum, 13.
- , Cells and Tissues, 710.
- Lichen-forming Ascomycetes, Culture of, without Algæ, 466, 829.
- Lichenes. See Contents, xxix.
- Liebermann, L., Embryochemical Investigations, 551.
- Liebscher, G., Supply of Food Constituents at Different Periods of the Growth of Plants, 614.
- Lierau, M., Roots of Araceæ, 607.
- Life, New Mode of, among Medusæ, 591.
- Life-box, Rousslet's, 112.
- Light, Action of, on Roots grown in Water, 995.
- , Influence of, on Oxidation, 714.
- , —, on the Growth of Leaves, 614.
- , —, on the Form and Structure of Leaves, 84.
- , —, upon Protoplasmic Movement, 242.
- Lighton, W. R., Notes on Staining Vegetable Tissues, 159.
- Lignier, O., Importance of the Foliar Fibrovascular System in Vegetable Anatomy, 985.
- Ligules and Stomata of Selaginella, 460.
- Limax agrestis, Anatomy and Histology of, 716.
- Lime, Formation of Oxalate of, in Leaves, 444.
- Limpriecht, K. G., Rabenhorst's "Cryptogamic Flora of Germany" (Musei), 91.
- Linckia multipora, Gemmation in, 431.
- Lindman, C., Pollination of Alpine Plants, 454.
- Lindner, P., Stained Yeast-preparations, 156, 519.
- Linton, E., Cestoid Embryos, 46.
- , Trematode in white of newly-laid Hen's Egg, 51.
- List, J. H., Double Staining, 847.
- Lister, A., Plasmodium of Badhamia and Brefeldia, 783.
- Live-box and Small Portable Binocular Microscope, 110.
- Living Preparations, Staining, 515.
- Lizard, Embryology of, 518.
- Loasaceæ, Morphology and Anatomy, 453.
- Locomotion, Aquatic, 19.
- of Caterpillars, Mode of, 726.
- Loeb, J., Influence of Light on Oxidation, 714.
- Loew, O., Action of Formose on Cells destitute of Starch, 85.
- , and T. Bokorny, Chemico-physiological Study of Algæ, 463.
- , —, Presence of active Albumen in the Cell-sap, 246.
- Logwood Stain, Acid, 517.
- Lohrer, O., Comparative Anatomy of Roots, 75.
- Loligo, Organ of Verrill in, 932.
- Longard, T., H. Buchner, and G. Riedlin, Method of calculating the rapidity of Bacterial Increase, 682.
- Loomis, H. P., Simple and Rapid Staining of the Tubercle Bacillus, 1053.
- Lophorhynchus, Kleinenberg on Development of, 579.
- Loranthaceæ, Formation of Roots in, 450.
- Lost Parts, Reproduction of, 414.
- Lothelier, A., Spines of certain Plants, 989.
- Louisville Microscopical Club, 304.
- Love-lights of Luciola, 30.
- Löwenthal, N., Demonstrating the Reticulated Protoplasm in the Interstitial Cells of the Ovary, 311.
- Lübimoff, N., Staining Tubercle and Leprosy Bacilli, 846.
- Luciani, L., and A. Piutti, Respiration of Silk-worm Ova, 726.
- Luciola, Love-lights of, 30.
- Ludwig, H., New and Old Holothurians, 591.
- Lugger, O., A New Method of Preserving Transparent Aquatic Insects for the Microscope, 667.
- Lukjanow, S. M., Intestinal Epithelium of Ascaris, 583.
- , Morphology of the Cell, 17.
- , Nuclei of Muscle-cells, 18.
- Lumbricidæ, Larval and Definite Excretory Systems in, 220.
- , Russian, 581.
- Lumbricus, Germ-bands of, 38.
- Luminosity of Fungi, 777.
- Luminous Marine Animals, Role of Symbiosis in, 929.
- Lundström, A. N., Colourless Oil-plastids in Potamogeton, 984.
- , Domatia, 87.

- Lundström, A. N., Masked Fruits, 79.  
 —, Mycodomatia in the Roots of Papi-  
 lionaceæ, 450.  
 —, Myrmecophilous Plants, 87.  
 Lung, Preparing large Sections of, 1043.  
 Lungs, Sarcina of, 634.  
 Lupin, Development of Aleurone-grains  
 in, 982.  
 Lutz, A., Life-history of *Ascaris lumbrico-*  
*coides* and *Tænia elliptica*, 426.  
 Lycopodium, Life-history of, 262.  
 Lymphatic Cell, Fusion of, into Plasmodia,  
 555.  
 Lyngbya and Phormidium, Relationship  
 between, 784.  
 Lyon, F. M., Dehiscence of the Sporangium  
 of *Ferax*, 90.
- M.
- Macallum, A. B., and Wright, R. R.,  
 Methods of studying *Sphyranura*, 149.  
 —, —, *Sphyranura osleri*, 47.  
 M'Cassey, G. H., Microscopy and Histology  
 for Office Students, 686.  
 Macchiati, L., Preparation of Pure Chloro-  
 phyll, 245.  
 M'Cook, H. C., Age and Habits of American  
*Tarantula*, 215.  
 —, New Orb-weaving Spider, 412.  
 —, Relations of Structure and Function  
 to Colour Changes in Spiders, 945.  
 —, Sense of Direction in *Formica rufa*,  
 212.  
 MacDonnell, —, Exhibition of Slides,  
 682.  
 Macé, E., Cultures of *Cladotrix dictio-*  
*toma*, 784.  
 MacGillivray, P. H., Polyzoa of Victoria,  
 403.  
 Machilis maritima, 408.  
 McIntire, S. J., Another Evening at the  
 Royal Microscopical Society, 141.  
 —, The Quekett Microscopical Club,  
 503.  
 Mackay, W. J., Intercoxal Lobe of certain  
*Crayfishes*, 577.  
 MacLeod, J., Fertilization of Flowers, 82.  
 MacMunn, C. A., Chromatology of  
 Sponges, 595.  
 M'Nab, W. R., Stomata and Ligules of  
*Selaginella*, 460.  
 Maddox's Moist Slide, 291.  
 Madreporaria, Anatomy of, 434.  
 Madreporic System of Echinodermata,  
 True Nature of, 57.  
 Madreporite of *Cribrella ocellata*, 431.  
 Magnesium Lamps, 494.  
 Magnification in Photomicrographs, 652.  
 — of Microscopic Objects in the Pro-  
 jected Images, Method of Representing  
 and Calculating, 135.  
 Magnifying Power, Highest, 819.  
 — of Objectives, Measurement of,  
 135.
- Magnus, P., Pollination of *Silene inflata*,  
 454.  
 —, Self-pollination of *Spergularia salina*,  
 994.  
 —, *Schinzia*, 631.  
 —, Sterility of Fungi, 467.  
 Mal nero of the Vine, 762.  
 Malasscz, L., Hot Plate Apparatus, 681.  
 —, Hot Stage, 488.  
 —, Improved hæmochromometer, 494.  
 —, Tubes for Microspectroscopic Ana-  
 lysis, 807.  
 Male Appendages on Female Crabs, 730.  
 Mall, F. P., First Branchial Cleft of  
 Chick, 387.  
 Mallard, E., Bertrand's Refractometer,  
 291.  
 Malvaceæ, &c., Comparative Anatomy of,  
 606.  
 Mammalian Ovaries, Preparing, 662.  
 — Ovum, Polar Globule of, 186.  
 — Testicle, Preparing and Staining, 844.  
 Mammals, Action of methyl-blue on, 1057.  
 —, Spermatogenesis of, 547, 707.  
 Man, Ancestry of, 193.  
 —, Larva of *Sarcophila Wohlfartii* in  
 Gum of, 944.  
 —, Protozoa, Parasitic in, 240.  
 —, *Tænia cucumerina* in, 955.  
*Mancinia areolata*, Development of, 434.  
 Manfredi, L., Fatty Matters in Cultivation  
 Media, 504.  
 Mangeri, C., On the preparation of gelatin  
 from agar-agar, 1040.  
 Mangin, L., Development of Flowers in  
 the Bud, 610.  
 —, Permeability of the Epidermis of  
 Leaves to Gases, 448, 763.  
 Manihot and Hevea, Laticiferous System  
 of, 72.  
 Manipulation, White's Elementary Micro-  
 scopical, 165.  
 Mantle of Gastropods and Dependent  
 Organs, 399.  
 Manton, W. P., Rudiments of Practical  
 Embryology, being working notes, with  
 simple methods for beginners, 315, 523,  
 667, 856, 1060.  
 —, and others, Photomicrography, 495.  
 —, —, Modern Methods of Imbedding,  
 842.  
 —, —, Sub-stage Condensers, 1029  
 —, —, Use and Abuse of the Micro-  
 scope, 822.  
 Marcacci, A., Influence of Movement on  
 Developing Eggs, 193.  
*Marcgraviaceæ*, Anatomy of, 449.  
 Marchal, P., Excretion in Brachyurous  
 Crustacea, 216.  
 Marchantiae, Hygroscopic Movements of  
 the Thallus of, 1001.  
 Marenzeller, E. v., Growth of *Flabellum*,  
 237.  
 Marilaun, A. K. v., Fertilization of *Euphrasia*, 767.

- Marine Algae, Crystalloids in, 463.  
 Marking Objects, May's Apparatus for, 113.  
 Marktanner's (T.) Photomicrographic Camera, 117.  
 Marloth, R., Salt-excreting Glands of Tamariscinæ, 249.  
 Marshall, A.M., and G. H. Fowler, 'Porepine' Pennatulida, 745.  
 —, Development of the Frog, 925.  
 —, C. F., Methods of Preparing Muscle for investigation, 147.  
 Marsson, H., Preparing Styra Balsam, 1057.  
 Marsupials, Spermatogenesis of, 386.  
 Martinotti, C., Improvements in the Silver-nitrate Method for Staining Nervous Tissue, 844.  
 Martinotti, G., Absorption of Anilin Pigments by living Animal Cells, 1055.  
 —, Nitrate of Silver Method, 319.  
 —, and L. Resegotti, Demonstrating Karyokinetic Figures, 516.  
 Masdevallia muscosa, Sensitive Labellum of, 616.  
 Maskell, W. M., Fresh-water Infusoria of Wellington District, New Zealand, 972.  
 —, Note on Micrasterias amricana, Ralfs, and its Varieties, 7, 169.  
 Massalongo, C., Distribution of Hepaticæ, 264.  
 Massart, J., Chemotactic Movements of Bacteria, Flagellata, and Volvocinæ, 771.  
 —, Irritability of Spermatozoa of Frog, 707.  
 Massee, G., Calostoma, Desv. (Mitremyces Nees), 780.  
 —, Gasterolichenes, 95.  
 —, Growth and Origin of Multicellular Plants, 83.  
 —, On the Type of a new Order of Fungi—Matuleæ, 173, 335.  
 —, Revision of the genus Bovista, 629.  
 —, Sexual Organs in *Æcidium*, 782.  
 'Mathematical Instruments,' Heather's, 501.  
 Mattiolo, O., Hygroscopic Movements of the Thallus of Marchantiæ, 1001.  
 — and L. Buscalioni, Root-tubercles of Leguminosæ, 251.  
 Matuleæ, The Type of a New Order of Fungi, 335.  
 Maupas, E., Conjugation of Paramæcium, 65.  
 —, — of Vorticellidæ, 752.  
 May's Apparatus for Marking Objects, 113.  
 Mayacæ, Roots and Rootlets in, 251.  
 Mayall, J., jun., Lectures on the Microscope, 140.  
 —, Necessity for a Sub-stage, 1024.  
 —, The Modern Microscope, 1036.  
 —, Recent Improvements of the Microscope: a Visit to Jena, 304.  
 Mayer, A., Exhalation of Oxygen by Fleahy-leaved Plants in absence of Carbonic Anhydride, 85.  
 —, P., Fixing Sections, 159.  
 —, S., Histological Pocket-book, 686.  
 —, Large Form of Abbe Camera Lucida, 113.  
 —, Microtechnique, 686.  
 Mayet, —, Artificial Serum for Computation of Blood-corpuscles, 162.  
 —, Improved Method for Enumerating Blood-corpuscles, 854.  
 Measurement of Magnifying-power of Objectives, 135.  
 Measuring Thin Films, 501.  
 Meat, Determination of the Number of Trichinæ or other Animal Parasites in, 164.  
 Meat-examining Microscope, Schieck's, 793.  
 Meates, A. E., Medium of High Refractive Index, 519.  
 Medicine, Photomicrography in, 119.  
 Media, Cultivation, Fatty Matters in, 504.  
 —, — of Schizomycetes in Coloured Nutritive, 823.  
 Medical Microscopical Society of Brooklyn, 304.  
 Medicinal Solutions, Thallophtes in, 459.  
 Medicine, The Microscope in, 654.  
 Medico-legal Identification of Blood-stains, 520.  
 Mediterranean Echinids, Researches on *Dorocidaris papillata* and other, 430.  
 — Synaptidæ, 233.  
 Medium, Alkali-albuminate as a Nutrient, 825.  
 — of High Refractive Index, 519.  
 —, Milk as a, 1038.  
 Medullary Canal and Primitive Streak, Relation of, 15.  
 Medusæ, Acraspedote, Scyphistomata of, 965.  
 —, Are there Deep-sea? 236.  
 —, New Mode of Life among, 591.  
 — from New England, 592.  
 Meehan, T., Irritability of the Stamens of *Echinocactus*, 261.  
 Megastoma entericum, 599.  
 — intestine, Encystation of, 439.  
 Mégnin, P., Fauna of the Tombs, 32.  
 Meissner, M., Physiology of Nutrition in Protozoa, 749.  
 Meloe, Germinal Layers of, 942.  
 Membrane, Protoplasm, and Nucleus of Plant-cells, Properties and Changes of, 980.  
 Membranes, Eternod's Apparatus for Stretching, 163.  
 Men and Animals, New Pathogenic Microphyte in, 634.  
 Menozzi, A., Chemistry of Germination, 767.  
 Mental Powers of Spiders, 575.

- Menze, O., Daily Assimilation of Carbohydrates, 994.
- Mer, E., Causes which produce Eccentricity of the Pith in Pines, 761.
- , Formation of the Duramen, 446.
- , Influence of Exposure on the Formation of the Annual Rings in the Savin, 762.
- Mergier, G. E., Practical Treatise on Physical Manipulations for Students in Medicine, 819.
- Metamorphosis, Alimentary Canal in, 943.
- Metanil-yellow, 677.
- Metastasis, Tannin and its connection with, 984.
- Methæmoglobin Crystals, 506.
- Methyl-blue, Action of, on Mammals, 1057.
- , Contribution to the Physiological Reaction of, 849.
- green for observing the Chemical Reaction and Death of Cells, 1049.
- Methylen-blue Reaction, Vital, of Cell-granules, 842.
- , Staining Nerve-endings with, 515.
- Iodide, Simple Method for Clearing, 677.
- Meyer, E., Organization of Annelids, 222.
- Mica Stage, Edmonds's Automatic, 111, 171.
- Michael, A. D., British Oribatidæ, 412.
- , Parasitism, 503.
- , Rhodium Oil, 167.
- Michaelsen, W., Enchytræidæ, 40.
- , New Enchytræidæ, 736.
- Michaud, G., Alkaloid and Sugar in Cyclamen, 759.
- Michel, A., Fusion of Lymphatic Cells into Plasmodia, 555.
- Micrasterias americana, Ralfs, and its Varieties, 7, 169.
- Microbe, Chromo-aromatic, 634.
- , Pathogenic chromo-aromatic, 1017.
- Microbes, Presence of a Phlogogenous Matter in the Cultures of certain, 634.
- Microbiology, Practical Manual of, 686.
- Microchæte, 99, 275.
- Micro-chemical Tests for Callus, 323.
- chemistry of Nerve-cells, 712.
- Micrometer, Radial, 293.
- Micrometers, Screw, of Reading-Microscopes, Testing, 814.
- Micrometric Measurements, Variation in, due to different Illumination, 814.
- Microscope for Horologists, Galfarelli's, 103.
- Micromillimetre, 502, 652.
- Micro-organisms and Fibrin, New Method for Staining, 675.
- , Cultivation of Anærobic, 824.
- , from Water and Soil, New and Typical, 789.
- , Improved Method for Cultivating, on Potatoes, 142.
- Micro-organisms, Leeuwenhoek's Discovery of, 522.
- , Milk-peptone-gelatin for Cultivating Pathogenic, 656.
- Microphotoscope, Galland-Mason's, 281.
- Microphysical Investigations, Apparatus for, 292.
- Microphyte, New Pathogenic, in Men and Animals, 634.
- Microscope, Ahrens' New Erecting, 1020.
- , A New Method of Preserving Transparent Aquatic Insects for, 667.
- , Advantages of a Knowledge of the Theory of, 296.
- “— and Kidney Disease,” 138.
- and Microscopical images, on the mode of determining and indicating correctly the amplification of, 304.
- and Telescope, 820.
- and the Museum, Preparing Tape-worms for, 148.
- , Apparatus. See Contents, xxxiii.
- , Babuchin's, 637, 794.
- , Bamberg's Spherometer, 280.
- , Bastin-Bullock, 285.
- , Bausch and Lomb Optical Co.'s Petrographical, 279.
- , Collins's Aquarium, 103.
- , Compound, Development of, 136.
- , Defective Objectives and the Binocular, 1025.
- , Duboscq's Projection, 108.
- , Dufet's Polarizing, 107.
- , Dumaige's Travelling, 476.
- , Electric, 285, 1025.
- for Horologists, Galfarelli's Micrometric, 103.
- in Medicine, 654.
- in the examination of Rock Sections by Polarized Light, The use of, 655.
- , Investigating the Effects of Remedies by, 1060.
- , Joblot's, 640.
- , Kibbler's Photomicrographic, 529.
- , Klein's Excursion, 1020.
- , Lamps, Schieck's, 490.
- , Lantern, The Advantages and Deficiencies of, 646.
- , Learning to see with, 495.
- , Leitz's Demonstration, 794.
- , Nachet's Crane-arm, 475.
- , Nägeli and Schwendener, 141.
- , Old Demonstration, 794.
- , Photomicrographic, Israel and Stenglein's, 115.
- , Physicians and the, 523.
- , Quantitative Determination of Silver by means of, 494.
- , Recent Improvements of: a visit to Jena, 304.
- , Schieck's Meat-examining, 793.
- , Travelling, 794.
- , Simple Method of Warming and Cooling under, 113.

- Microscope, Small Portable Binocular, and a Live-box, 110.  
 — stands. See Contents, xxxii.  
 ' —, Student's Handbook to,' 137.  
 —, Theory of, Nägeli and Schwendener, 140.  
 —, Thury's Five-tube, 792.  
 —, Use and Abuse of, 822.  
 —, Watson and Son's Anglo-Continental or Student's, 797.  
 — with "Continental" Fine-adjustment, Pritchard's, 1022.  
 —, Zeiss's Ila., 637, 794.  
 Microscopes, American, 652.  
 —, —, A Complaint, 285, 482.  
 —, — and Foreign, 797.  
 —, — —; the Verdict of an Impartial Expert, 798.  
 —, Ancient, 304.  
 —, Campani's Compound, 109.  
 —, Galileo's, 639.  
 —, Hensoldt's Reading, 640.  
 — of historic interest, Recently discovered, 485.  
 —, Testing Screw-micrometers of Reading, 814.  
 Microscopic Algae, Collecting, 504.  
 — manipulation, 1060.  
 "Microscopical Advances," 137, 141.  
 — Club of the Buffalo Society of Natural Sciences, 305.  
 — Optics and the Quekett Club Journal, 817, 1034.  
 — Society, Medical, of Brooklyn, 304.  
 — — of Pittsburg, 305.  
 — Societies, Local, 304.  
 Microscopy and the Study of Rocks, 820.  
 —, examinations in, 654.  
 Microspectroscopic Analysis, Tubes for, 807.  
 Microspora, 94.  
 Microsyringe, Beck's, 849.  
 Microtome, Accessory for rapid Cutting with the Thoma, 840.  
 —, — to the Cambridge Rocking, 669.  
 — and Technique, Pharmacognostic, 513.  
 —, Dale's, 317.  
 — for cutting under alcohol, Schiefferdecker's, 152.  
 — for cutting whole sections of the Brain and other organs, Bruce's, 837.  
 —, Cathart Improved, 1047.  
 — freezing, Combining Weigert's Hæmatoxylin-copper Stain for Nerve-fibre with the use of, 1051.  
 —, Schwabe's Sliding, 668.  
 —, Thate's New, 839.  
 — with fixed knife and automatic movement of the object, 842.  
 Mikosch, K., Structure of Starch-grains, 443.  
 Milk as a Medium, 1038.  
 —, media prepared from, for micro-cultivation, 145, 658.  
 Milk-peptone-gelatin for cultivating Pathogenic Micro-organisms, 656.  
 Millar, Dr. J., Death of, 325.  
 Millepora pleniata, Sexual Cells and Early Stages in Development of, 964.  
 —, Sex-cells and Development of, 236.  
 Miller, M. N., New Injecting Mass, 518.  
 —, Practical Microscopy: A course of Normal Histology for Students and Practitioners of Medicine, 166, 523.  
 Milne-Edwards, A., Fresh-water Crabs of Africa, 415.  
 Mimicry and Parasitism of *Camponotus lateralis*, 30.  
 Mimosa pudica, Movement of Leaf of, 457.  
 Minusops and Payena, Laticiferous product of, 759.  
 Minerals, Rock-forming, 823.  
 Mingazzini, P., Reticulum of Muscle-fibre, 928.  
 Minnesota, Arthur's Report on, 89.  
 Minot, C. S., "American Microscopes—A Complaint," 285, 482.  
 —, The Mounting of Serial Sections, 682.  
 Miquel, P., Bacillus living at a temperature exceeding 70° C., 1013.  
 —, Determining the percentage of Atmospheric Bacteria, 1060.  
 —, On the relative value of the processes employed for the microscopical analysis of water, 856.  
*Mischococcus confervicola*, Development of, 632.  
 Mischoldt, A., Preservation of Parts and Organs of Animals, 658.  
 Mistletoe, Biology of, 86.  
 —, Development of the Flowers of, 990.  
*Mitremyces Nees*, *Calostoma*, Desv., 780.  
 Mittmann, R., Anatomy of Spines, 763.  
 Mitoses, Staining, 674.  
 Möbins, K., Direct Division of Nucleus in *Euplotes harpa*, 436.  
 —, Folliculina ampulla, 598.  
 —, M., Anatomical Structure of the Leaves of Orchidæ, 608.  
 —, New Fresh-water Floridæ, 93.  
 Models in Metal of Microscopical Preparations, 165.  
 Moeller, H., Tannin and its connection with Metastasis, 984.  
 Möhring, W., Branching of the Frond of Ferns, 619.  
*Moina bathycoler*, and the greatest depths at which Cladocera are found, 578.  
 Moist and Gas Chambers, 287.  
 Molgulidæ, Symbiotic Fungus in, 782.  
 Molisch, H., Secretion from the Roots, 246.  
 —, Thyllæ, 988.  
 Moll, J. W., Application of Paraffin Imbedding in Botany, 315.  
 Müller, A., Cultivation of Lichen-forming Ascomycetes without Algae, 466, 829.  
 —, "Spermatia" of the Ascomycetes, 1006.

Mollusca. See Contents, x.  
 Molluscoida, See Contents, xi.  
 Monal, —, and P. v. Tieghem, Sub-epidermal Network of the Root of Geraniaceæ, 986.  
 Monas Dunali, 973.  
 Moniez, R., New Parasite of the Silk worm, 471.  
 —, *Tœnia nana*, 229.  
 Moniligaster, Reproductive Organs of, 221.  
 Monocotyledons, Formation of Lateral Roots in, 762.  
 —, Germination of, 767.  
 —, Vascular Bundles in the Rhizome of, 74.  
 Moore, S. Le M., Epidermal Chlorophyll, 245.  
 —, Influence of Light upon Protoplasmic Movement, 242.  
 —, Studies in Vegetable Biology, 996.  
 Morgan, C. L., Elimination and Selection, 927.  
 —, T. H., Chitin Solvents, 833.  
 Morini, F., Ascophorous form of *Penicillium candidum*, 1008.  
 —, Germination of the Spores in *Ustilago*, 270.  
 —, Sexuality of *Ustilagineæ*, 269.  
 Morot, L., Identity of *Polyporus abietinus*, Fr. and *Irpex fusco-violaceus*, Fr., 468.  
 Mosso, A., Methods of Examining Blood-corpuscles, 1040.  
 —, Methyl-green for observing the Chemical Reaction and Death of Cells, 1049.  
 Moths and Butterflies, Villi on the Scales of, 498.  
 Mould, New, 1010.  
 Moulds, Preparing, 150.  
 Mounting. See Contents, xi.  
 Mounts, Making Photographic, 854.  
 Mouse, Vestiges of Zonary Decidua in, 186.  
 Mucedinæ, New, 631.  
 Mucous Cells in Mussels, 402.  
 — Gland, so-called, of Male *Cypridæ*, 731.  
 — of *Urochæta*, 422.  
 "Muffe," Composition of, 633.  
 Müller, C., New *Sphagna*, 91.  
 —, Secreting Canals of *Umbelliferæ* and *Araliaceæ* contained in the Phloem, 605.  
 —, F., Germination of the *Bicuiba*, 613.  
 —, H., "Edelfäule" of Grapes, 1009.  
 —, J., Action of Lichens on Rocks, 95.  
 —, N. J. C., Atlas of wood structure represented in photomicrographs, 651.  
 —, W., Scent-glands of *Phryganidæ*, 406.  
 Multicellular Organs, Movements of Irritation of, 615.  
 — Plants, Growth and Origin of, 83.  
 Multinucleate *Infusoria*, 597.  
 Munchausen still alive, 655.  
 Müntz, A., Occurrence of the Elements of Sugar of Milk in Plants, 604.  
 1888.

*Murex*, Form and Development of Spermatozoa in, 200.  
 Murray, G., and L. A. Boodle, *Spongiocladia*, 1002.  
 Musca, Development of, 944.  
 — vomitoria, Development in Egg of, 572.  
 Muscinæ. See Contents, xxvii.  
 Muscle for investigation, Methods of Preparing, 147.  
 —, Staining-differences of Unstriped, and Connective Tissue Fibres, 843.  
 —, Striped, Distribution of, 714.  
 —, —, of Arthropods, 941.  
 Muscle-cells, Nuclei of, 18.  
 —fibre, Reticulum of, 928.  
 Muscles of *Lamellibranchiata*, Structure of, 935.  
 —, Longitudinal, and Stewart's Organ in *Echinothurids*, 429.  
 — of Molluscs, Microscopic Structure of, 199.  
 —, Striated, in Mollusca, 402.  
 Musculature of Heteropoda and Pteropoda, 560.  
 Museum and the Microscope, Preparing Tape-worms for, 148.  
 Mussels, Mucous Cells in, 402.  
 Mycodomatia in the Roots of *Papilionaceæ*, 450.  
 Mycorhiza, New Forms of, 268.  
 Myelocytes of Invertebrates, 929.  
 Mutualism, Remarkable Case of, 557.  
 Mycological Notes, 783.  
 Mycology, Baumgarten's Pathological, 791.  
 Myriopoda. See Contents, xiii.  
*Myristica, surinamensis*, Aleurone-grains in the Seed of, 72.  
 Myrmecophilous Plant, *Humboldtia laurifolia* as, 88.  
 — Plants, 87, 998.  
 Myrtle-wax Imbedding Process, 151.  
 Myzostoma, Nervous System of, 231.  
 Myzostomida, 'Challenger,' 590.

## N.

Nachet's (A.) Crane-arm Microscope, 475.  
 — Gas Chamber, 289.  
 Nagel, W., Human Ovum, 547.  
 Najadæ, Histology of, 205.  
 Nansen, F., Histological Elements of the Central Nervous System, 194.  
 —, Methods of investigating Structure of Nerve-tissues, 312.  
 —, Nervous System of *Myzostoma*, 231.  
 Naples, *Gorgonidæ* of, 435.  
 Narcissus, Formation of Sugars in the Septal Glands of, 759.  
 Nasal Mucus, Vibrio from, 99.  
 Nassonoff, —, Boring Clionids, 965.  
 Nebaliæ, Second Species of Turbellarian Living on, 428.  
 Nectar of *Rhododendron*, 603.

- Nectary, Floral, of *Symphoricarpus*, 255.  
 Needle-Teasing, James's, 520.  
 Neisser, A., Preparing Sections from Test-tube Cultivations, 671.  
 —, Spore-formation in the Bacilli of *Xerosis conjunctivæ*, *Streptococci*, and *Cholera spirilla*, 1016.  
 Nelson, E. M., *Amphipleura pellucida*, 819.  
 —, A simple Correction for Curvature of Image, 1036.  
 —, Curious Interference Phenomena with *Amphipleura pellucida*, 302.  
 — — — Optical Effect, 172.  
 —, Development of the Compound Microscope, 136.  
 —, Mechanical Stage, 477.  
 —, New form of mechanical stage, 334.  
 —, Nobert's Bands, 305.  
 —, Nomenclature of eye-pieces and objectives, 652.  
 —, On a new Eye-piece, 111.  
 —, On the Formation of Diatom Structure, 495.  
 —, On the Interpretation of a Photomicrographic Phenomenon by the Abbe Diffraction Theory, 819.  
 — Photomicrographic Focusing Screen, 119.  
 —, Spectra of *Pleurosigma angulatum*, 303.  
 —, Tests for Modern Objectives, 816.  
 —, "The Microscope," Nägeli and Schwendener, 141.  
 —, True and False Images in Microscopy, 819.  
 —, J., Fixing Sections to the Slide, 853.  
 —, S. N., Methods of examination of Bacteria for laboratory purposes, 686.  
 Nelson-Curties Microscope for Photomicrography, 691.  
 Nelumbium, Anatomy of, 765.  
 Nemathelminthes. See Contents, xv.  
*Nematus Capræ*, *Cecidium* of, 458.  
 Nemertea, 'Challenger,' 52.  
 Nemerteans, Lateral organs of, 51.  
 Nephridia of Earthworms, 421.  
 — of *Lanice conchilega*, 735.  
 Nephrocytium, Reproduction of, 1013.  
 Nerve-cells and Axis-cylinder, 556.  
 — — — and Peripheral Ganglia, Preparation of, 506.  
 — — —, Micro-Chemistry of, 712.  
 — — —, Two new Methods for preparing, 658.  
 Nerve-centres and Sensory Organs of Articulata, 403.  
 — — — -endings in the Leech, 952.  
 — — —, Staining, with Gold Chloride, 155, 673, 674.  
 — — —, —, with Methylene-blue, 515.  
 — — — -fibre, Combining Weigert's Hamatoxylin-copper Stain for, with the use of the freezing Microtome, 1051.  
 — — —, Histology of, 395.  
 — — —, Structure of, 197.  
 Nerve-sections, Half-clearing method of preparing, 680.  
 — — — -terminations in Lepidoptera, 943.  
 Nerve-tissues, Methods of investigating Structure of, 312.  
 Nerves, Methods for Examining the Structure of the Cerebrospinal, 1011.  
 Nervous Organs, Central, in health and disease, Methods for Investigating the Structure of, 1011.  
 — — — System and Vascular Apparatus of Ophiurids, 57.  
 — — —, Central, Histological Elements of, 194.  
 — — —, —, of Tunicata, 26.  
 — — —, —, Safranin as Stain for, 1051.  
 — — —, Classification of Gastropods, based on the Arrangement of, 401.  
 — — — of *Amphioxus*, 390, 923.  
 — — — of *Aplysia*, 20.  
 — — — of *Chætopterns Valenciæ*, 225.  
 — — — of Echinodermata, 741.  
 — — — of *Myzostoma*, 231.  
 — — — of Ophieliaceæ, Preparing, 509.  
 — — — of *Phylactolamatus* Fresh-water Bryozoa, 402.  
 — — — of Prosobranchs, 21.  
 — — — of Pteropods, 25.  
 — — —, Physiology of, 559.  
 — Tissue, Improvements in the Silver-nitrate Method for Staining, 841.  
 — Tracts in Alcyonids, 61.  
 Network, Sub-epidermal, of the Root of Geraniaceæ, 986.  
 —, Super-endodermal, of the Root of Leguminosæ and Ericaceæ, 986.  
 —, Supporting, in the Cortex of the Root, 986.  
 Neuhaus, R., Adaptation of the ordinary Eye-piece for Photomicrography, 1032.  
 —, Focusing Arrangement, 809.  
 —, Guide to Photomicrography for Physicians, Botanists, &c., 119.  
 —, Photomicrographic Camera, 293.  
 —, The Development of Photomicrography in the last two years, 813.  
 Neumayer, G., Guide to Scientific Observations in Travelling, 823.  
 Neunmayr, M., Relationships of Foraminifera, 66.  
 New England, Medusæ from, 592.  
 — Jersey, Essex County Microscopical Society of, 304.  
 — York, Central, Microscopical Club, 304.  
 — Zealand, Fossil Marine Diatoms from, 94.  
 — — —, Wellington district, Fresh-water Infusoria of, 972.  
 Newcombe, F. C., Dissemination of the Spores of *Equisetum*, 1000.  
 Ney, O., Magnesium Lamps, 494.  
 Nickel, E., The Colour Reactions of Carbon Combinations. I. Colour Reactions of an Aromatic Character, 849.

- Nicholson, H. A., Structures and Affinities of *Parkeria*, 237.
- Nicotra, L., Pollination of *Serapias*, 256.
- Nikiforow, M., Short Studies in Microscopical Technique, 856.
- Nuclear Carmine Stain, 1050.
- , Safranin as a Stain for the Central Nervous System, 1051.
- , Simple Method for Fixing Cover-glass Preparations, 1047.
- , Staining the Spirochæte of Relapsing Fever, 1054.
- Nitella, New, 1001.
- Nitrate of Silver Method for Staining, 319.
- Nitric Acid in Plants, Formation of, 616.
- Nitrogen, Absorption of, by Plants, 770.
- of Vegetation, Sources of, 261.
- Noack, F., Influence of Climate on the Cuticularization and Thickening of the Leaves of some Coniferæ, 608.
- Nobbe, F., Production of Sex and Phenomena of Crossing, 256.
- Robert's Bands, 305.
- Noeggerath, E., On a new method of bacteria cultivation on coloured nutrient media for diagnostic purposes, 831, 1039.
- Nöll, F., Growth of the Cell-wall, 442.
- , Influence of External Forces on the Form of Plants, 456.
- , Protonema of *Schistostega osmundacea*, 774.
- , Staining Membranes in Living Siphonæ, 516.
- , F. C., Natural History of Siliceous Sponges, 745.
- , Silicoblasts, 596.
- Nordqvist, O., *Moina bathycola* and the greatest depths at which Cladocera are found, 578.
- Nordstedt, O., New *Chara*, 1001.
- , New *Nitella*, 1001.
- Norman, A. M., New Crustacean Parasite, 418.
- Norse Alcyonaria, 239.
- Nose-piece for Changing Objectives, Dumaige's, 488.
- Nostocacæ, Cellular Envelope of the Filamentous, 632, 1012.
- Nostochinæ, Filamentous Heterocystous, 472.
- Notochlæna, Apogamy in, 999.
- Nott, T. E., Staining of Tubercle Bacilli, 849.
- Nuclear and Cell Division, 243, 440.
- Carmine Stain, 1050.
- Fission, Preparing Testicle for Observing, 146.
- Origin of Hyaloplasm, 440.
- Stain, New, and Note on Fixation, 675.
- Nuclei of Muscle-cells, 18.
- , So-called Free, in the Nutrient Yolk of Bony Fishes, Origin and Significance of, 706.
- , Three, in Pollen-grains, 440.
- Nuclein and Plastin, Demonstrating, 505.
- Nucleus and Cell, Division of, 978.
- , Artificial, Deformations of, 196.
- , Changes of Position of, 390.
- , Chemistry of, 390.
- , Direct Division of, in *Euplotes harpa*, 436.
- , Division of, Cell-division, and Impregnation, 600.
- in Cell-division, Part taken by, 69.
- in *Oscillaria* and *Tolypothrix*, 275.
- , Membrane, and Protoplasm of Plant-cells, Properties and Changes of, 980.
- , Relation between the Function and Position of, 601.
- Nusbaum, J., Germinal Layers of *Meloe*, 942.
- , M., First Changes in Fecundated Ovum of *Lepas*, 218.
- Nutmeg, Contents of the Cells of the Aril of, 760.
- Nutrient Media, Coloured, 1039.
- for microbes from milk, on the preparation of solid, 658.
- Medium for Micro-organisms, Albumen of Plovers' Eggs, 1037.
- Nutrition of Phanerogamia. See Contents, xxv.
- , Physiology of, in Protozoa, 749.
- Nutritive Media, Preparation of, 655.
- Nuttall's, G., Warm Chamber, 1027.
- Nutting, C. C., New Species of *Acineta*, 438.
- Nyctagineæ, 82.
- Nyctiphanes norvegica, Photospheria of, 415.
- O.
- Oaks, Retrogression in, 88.
- Oamaru Deposit, Remarkable Spicules from, 967.
- Oberstein, H., Methods for Investigating the Structure of the Central Nervous Organs in health and disease, 1041.
- Objectives. See Contents, xxxiii.
- Odontophores of Mollusca, Photomicrographs of, 333.
- Odoriferous Glands of Blaps, 943.
- Office Students, Microscopy and Histology for, 686.
- Ohio State Microscopical Society, 305.
- Oidium *Fragariæ*, 274.
- Oil-passages in the Roots of Compositæ, 447.
- -plastids, Colourless, in *Potamogeton*, 984.
- -receptacles in the Roots of Compositæ, 760.
- Olbers, A., Fruit of *Borraginæ*, 255.
- Oleina, Ascomycetes and *Podocapsa*, New Genera of, 271.
- Olfactory Ganglia of Cephalopods, 931.
- Oligochaeta, Homology of Segmental Organs and Efferent Ducts of Genital Products in, 419.

- Oligochaeta, Limicolous, Formation of Embryonic Layers and Coelom, 735.  
 —, So-called Prostate Glands of, 221.
- Oliver, F. W., Microchemical Tests for Callus, 323.  
 —, Phenomenon analogous to Leaf-fall, 88.  
 —, Sensitive Labellum of *Masdevallia muscosa*, 616.  
 —, Sieve-tubes in the *Laminariæ*, 265.  
 —, *Trapella*, Oliv., a new Genus of *Pedalineæ*, 392.  
 —, L., Physiological Experiments on Organisms of Glairine and Baregine, 1019.
- Omphila and Guepinia, 1008.
- Onion, *Anguillulidæ* of, 585.  
 —, Occurrence of Starch in, 983.
- Onoclea *Struthiopteris*, Hoffm., Development of, 618.
- Oontogeny of Marine Bryozoa, 936.
- Oogenesis and Reproductive Organs of *Helix*, 398.
- Oophyte of *Trichomanes*, 617.
- Opheliacea, Preparing the Nervous System of, 509.
- Ophiurid, Remarkable, from Brazil, 591.
- Ophiurids, Anatomy of, 958.  
 —, Morphology of, 432.  
 —, Nervous System and Vascular Apparatus of, 57.
- Optometer and apparatus for measuring the foci of, and centering of optical lenses—North Harehek's System, 819.
- Opuntia, Production of Vegetative from Fertile Shoots of, 768.
- Orbitolites *complanata*, var. *laciniata*, Reproductive Condition of, 693, 1065.
- Oreanet, Employment of tincture of, in histological technique, 1056.
- Orchestia, 949.
- Orchid Hybrids, Bigeneric, 257.
- Orchidæ, Anatomical Structure of the Leaves of, 608.  
 —, Flower of, 764.
- Orchids, Self-fertilization and Cleistogamy in, 994.
- Oribatidæ, British, 412.
- Orobanche, Biology of, 85.  
 —, Development and Structure of, in a young stage and of its suckers, 80.
- Orr, H., Embryology of *Anolis*, 387.  
 —, — of Lizard, 548.
- Orthoneura, 400.
- Osborn, H. L., Microscope in Medicine, 166.  
 —, Microscopical Societies should combine for work, 305.  
 —, Practical Courses, 324.  
 —, Studies for Beginners, 686, 856.
- Oscillaria and *Tolypothrix*, Nucleus in, 275.
- Osmic Acid and Gold Chloride Methods, 846.
- Ossification Preparations, Staining of, 154.
- Ostracoda," "On the Generative Organs of, 168.
- Ova, Abnormal, of *Ascaris megaloccephala*, 953.  
 — and Spermatozoa, Formation of, in *Spongilla fluviatilis*, 966.  
 — and Tissues, Bacteria-like Bodies in, 31.  
 —, Animal, Formation of Polar Globules, 705.  
 —, *Ascaris*, Maturation and Division of, 42.  
 —, Capillary Slide and accessories for the examination of, 801.  
 — of Amphibia, Preparing, 146.  
 — of *Ascaris megaloccephala*, Preparing, 508.  
 — of *Bdellostoma*, 192.  
 —, Respiration of Silk-worm, 726.  
 —, Segmentation of Teleostean, 191.
- Ovarian Ova and the Primitive Foraminifera, Resemblance of, 706.
- Ovaries, Preparing Mammalian, 662.
- Ovary, Histology of, 713.  
 —, Reticulated Protoplasm in the Interstitial Cells of, 311.
- Oven and Water-bath, Reeves's, 163.
- Overton, C., Conjugation of *Spirogyra*, 625.
- Oviatt, B. L., Permanent Preparations of Tissues treated with Potassium Hydrate, 147.
- Ovules of Grasses, 611.  
 — of Plantago, 452.  
 — of Rumex, 764.
- Ovum, Animal, 13.  
 —, Axis of Frog, 15.  
 —, Human, 517.  
 —, Maturity of, 15.  
 — of *Lepas*, First Changes in Fecundated, 218.  
 —, Polar Globule of Mammalian, 186.
- Oxalis rubella, Germination of, 613.  
 —, Subterranean Shoots of, 988.
- Oxidation, Influence of Light on, 714.  
 —, Physiological, in the Protoplasm, 454.  
 — -process in Plants after death, 88.
- Oxygen, Exhalation of, by fleshy-leaved Plants in absence of Carbonic Anhydride, 85.

## P.

- Pachydrilus enchytræoides*, Histology of, 222.
- Pagan's "Growing Slide," Modification of, 1028.
- Paladino, G., Preparing Mammalian Ovaries, 662.
- Palæmon and Hippolyte, Parasitic Castration in the Eucyphotes of, 414.
- Pal-Exner Method of Staining Sections of the Central Nervous System, 1057.
- Palladin, W., Formation of organic acids in the growing parts of plants, 247.

- Palms, Germination of, 257.  
 Palpiform Organs of Crustacea, 413.  
 Palps of Butterflies, Basal Spot on, 943.  
 Paneth, J., Secreting Cells of Intestinal Epithelium, 556.  
 Pantanelli, D., Mounting small Organisms—Disaggregation of Rocks, 315.  
 Pantocsek, J., Fossil Diatoms of Hungary, 466.  
 Paper, Microscopical Examination of, 521.  
 Papilionaceæ, Mycodomatia in the Roots of, 450.  
 Papulaspora, New, 631.  
 Paraffin, Homogeneous, 151.  
 — Imbedding in Botany, Application of, 315, 672, 834.  
 Paramæcium, Conjugation of, 65.  
 Parasite, New Crustacean, 418.  
 —, —, of the Silk-worm, 471.  
 — of the Rotatoria, Chytridium elegans, 1011.  
 — of Telphusa, 40.  
 Parasites of *Teredo navalis*, 199.  
 — of the Higher Fungi, 1011.  
 — of the Pezizaceæ, 781.  
 —, Phanerogamous, Origin of the Suckers in, 80.  
 Parasitic Algæ on the Sloth, 624.  
 — Fungi, Character of the Injuries produced by, upon their Host-plants, 470.  
 — Fungus on Pineapple, 780.  
 — on Salt-fish, 781.  
 — on the Plane, 631.  
 — Infusoria, New, 436.  
 — Protozoa, 974.  
 — in Man, 240.  
 — Rotifer, *Discopus Synaptæ*, 52.  
 Parasitism and Mimicry of *Camponotus lateralis*, 30.  
 — of the Truffle, 780.  
 Parker, G. H., Eyes in Scorpions, 411.  
 —, W. N., On the objects of the Biological and Microscopical Section of the Cardiff Naturalists' Society, 686.  
 Parkeria, Observations on, 757.  
 —, Structure and Affinities of, 237.  
 Parthenogenesis in *Bombyx mori*, 571, 725.  
*Patella vulgata* and *Sepia officinalis*, Salivary Glands of, 932.  
 Pathogenic chromo-aromatic Microbe, 1017.  
 Pathological Investigations, Methods for, 154.  
 — Mycology, Baumgarten's, 791.  
 — Structure of the Cell-nucleus, 391.  
 Patouillard, N., Classification of the Agaricinæ, 467.  
 —, New Tubercularia, 779.  
 —, Prototremella, 1007.  
 Patten, W., Eyes of Arthropods, 209, 938.  
 Pawlowsky, A. D., Cultivation of *Bacillus Tuberculosis* on Potato, 1038.  
 Payena and *Mimusops*, Laticiferous product of, 759.  
 Peach-leaves, "Curl" of, 89.  
 Peal, C. N., Microscopy for Beginners, 686.  
 Peckham, G. W., Senses of Ants, 571.  
 — and E. G., Mental Powers of Spiders, 575.  
 Pedalineæ, *Trapella*, Oliv., a new Genus of, 992.  
 Pediastrum, Development of, 624.  
 Pedicellina, Anatomy of, 208.  
 Pelagic Animals at Great Depths, and their Relations to the Surface Fauna, 558.  
*Pelanechinus corallinus*, New Features in, 233.  
 Pelletan, J., Diatomaceæ, 667.  
 —, Objectives, 111.  
*Pelomyxa palustris*, Minute Structure of, 11, 171.  
 Pelseneer, P., 'Challenger' Pteropoda (*Gymnosomata*), 26.  
 —, P. N., Classification of Gastropoda by the Characters of the Nervous System, 933.  
 —, Lamellibranchiata without gills, 564.  
 —, Nervous System of Pteropods, 25.  
*Peltophæria*, New Genus, 630.  
 Pendent Organs, Mechanical System of, 75.  
*Penicillium candidum*, Ascophorous form of, 1008.  
 — crustaceum, Asei of, 271.  
 Pennatula, New, from the Bahamas, 593.  
 Pennatulida, 'Porcupine,' 745.  
 Penny, W. G., Eye-pieces—Physical Aberration and Distortion, 616.  
 Penzig, O., Anatomy and Diseases of Aurantiaceæ, 453.  
 Pereyaslawzewa, S., Development of *Gammarus*, 949.  
 Perforation in the Walls of Vessels, Systematic Value of, 447.  
 Pericardial Gland in Lamellibranchs, 720.  
*Perichæta*, Anatomy of, 422.  
 Periderm, Formation of, 761.  
 — of Leguminosæ, 606.  
 — of Rosaceæ, 987.  
*Peridermium Pini*, 1009.  
 Peridineæ, Parasites of, 781.  
 —, Spore-formation in, 437.  
*Peripatus capensis* and *P. Novæ Zealandiæ*, Anatomy of, 577.  
 —, Development of a South American, 410.  
 —, — of the Cape Species of, 409.  
 —, Monograph of the Genus, 576.  
 — *Novæ-Zelandiæ*, Development of, 33.  
 Peripheral Ganglia and Nerve-cells, Preparation of, 506.  
*Periplaneta orientalis*, Thermic Experiments on, 31.  
 Peristome, 1000.  
 —, Internal, of Mosses, 461.  
 — of Mosses, 263, 620.  
 Permeability of Protoplasm, 601.  
 — of the Epidermis of Leaves to Gases, 448, 763.

- Peronospora of the Rose, 1008.  
 — viticola, 1008.  
 Perrier, R., Kidney of Prosobranch Gastropods, 399, 715.  
 Perroncito, E., Chytridium elegans, n. sp., a Parasite of the Rotatoria, 1011.  
 —, Encystation of Megastoma intestinale, 439.  
 — and L. Valada, Composition of "Muffe," 633.  
 Peter, A., Batrachospermum, Chantryasia, and Lemanca, 464.  
 Petersen, O. G., Reticulations in Vessels, 986.  
 Petiole, Distribution of Fibro-vascular Bundles in, 74.  
 — of Dicotyledons, 610.  
 Petit, L., Distribution of Fibro-vascular Bundles in the Petiole, 74.  
 —, Effects of Lesion of Supra-oesophageal Ganglia in Snails, 717.  
 —, Effects of Lesions of the Supra-oesophageal Ganglia of the Crab (Carcinus Menas), 730.  
 —, Petiole of Dicotyledons, 610.  
 Petri, R. J., New Method of Demonstrating and Counting Bacteria and Fungi Spores in the Air, 1059.  
 Petrographical Microscope, Bausch and Lomb Optical Co.'s, 279.  
 Petromyzon, Development of, 388, 549.  
 Petrone, L., Methods for examining the Structure of the Cerebrospinal Nerves, 1041.  
 Pfeiffer, W., Chemotactic Movements of Bacteria, Flagellata, and Volvocineæ, 770.  
 Pfeifer, A., Cooler for quickly setting Gelatin Plates, 828.  
 Pfützer, E., Flower of Orchidæ, 764.  
 —, New Imbedding Material, 316.  
 Pfützer, W., Pathological Structure of the Cell-nucleus, 391.  
 Phaeophyceæ, Physiology of, 462.  
 Phæozoosporeæ, New Genera of, 465.  
 Phalangida, Brain of, 576.  
 Phalloidei, Stretching of the Receptacle of, 629.  
 Phanerogamia, Anatomy and Physiology of. See Contents, xx.  
 Pharbitis triloba, Seeds of, 764.  
 Pharmacognostic Microtome and Technique, 513.  
 Phenol in Microscopical Technique, 847.  
 Philibert, —, Internal Peristome of Mosses, 461, 1000.  
 —, Peristome of Mosses, 263, 620, 1000.  
 Philicthydæ and Lernaæus, 217.  
 Phillips, W., Luminosity of Fungi, 777.  
 Ploem, Secreting Canals of Umbellifera and Araliaceæ contained in, 605.  
 Pliogonous matter, Presence of a, in the Cultures of certain Microbes, 634.  
 Pholas dactylus, Photogenic Property of, 26.  
 Phormidium and Lyngbya, Relationship between, 784.  
 Phosphorescence in Myriopoda, 945.  
 Phosphorescent Bacilli, Photographing, by means of their own light, 813.  
 — Bacillus, 277.  
 — Bacteria from Sea-water, 101.  
 — Lumbricids, Type of a New Genus, 39.  
 Phosphoric Acid and Phosphorous in Plants, 760.  
 Photodrilus phosphoreus, New Genus of Phosphorescent Lumbricids, 39.  
 Photogenic Property of Pholas dactylus, 26.  
 Photographing 'moving Microscopic Objects, 812.  
 Photographs v. Drawings.—Screen for the Abbe Camera Lucida, 809.  
 Photomicrographs of Diatoms, 295.  
 — of the Odontophores of Molluses, 333.  
 — with high amplification, 526.  
 —, Zeiss's, 525.  
 Photomicrography. See Contents, xxxiv.  
 Photomicroscope, "Stein's" Large, 295.  
 Photospheria of Nyctiphanes norvegica, 415.  
 Photoxylin for Imbedding, 834.  
 Phycocytetes, Reproductive Organs of, 579.  
 Phryganida, Scent-glands of, 496.  
 Phthisical Sputum, The value of Microscopical examination of, as a means of giving a correct Prognosis, 686.  
 Phycoerythrin, 622.  
 Phycomycetes, Cultivation of, 469.  
 Phycohematin, 265.  
 Phycotheca universalis, Hauck and Richter's, 627.  
 Phyllocearida, 'Challenger,' 36.  
 Phylloxera, Brain of, 408.  
 Phylogeny of Echinodermata, &c., 956.  
 — of Lamellibranchs, 565.  
 — of Protozoa, 967.  
 Physalospora Bidwellii, Formation of the Ascii in, 629.  
 Physicians and the Microscope, 523.  
 Physophore, New, 592.  
 Pichi, P., Thickening of the Cell-walls in the Leaf-stalk of Aralia, 70.  
 —, Tubercles on the Roots of Leguminosæ, 608.  
 Picrocarmine, Preparing, 518.  
 Piersol, G. A., Benda's Modified Copper-hæmatoxylin, 158.  
 —, Drawings v. Photographs.—Screen for the Abbe Camera Lucida, 809.  
 —, Homogeneous Paraffin, 151.  
 —, Laboratory Jottings, 166.  
 —, Substitute for Clearing, 160.  
 Pilacre, 1009.  
 Pilliet, A., Differential Staining of the Tissues of Living Animals, 842.  
 —, Glandular Cells of Stomach, 393.

- Pimina, a new Genus of Hyphomycetes, 780.
- Pinakoscope, Ganz's, with Dreyfus's Reflector, 796.
- Pine-apple, Fungus Parasitic on, 780.
- Pines, Causes which produce Eccentricity of the Pith in, 761.
- Pinguicula, Arrangement of Fibro-vascular Bundles in, 74.
- , Observations on, 987.
- , Propagula of, 764.
- Pirota, R., Endosperm of Gelseminæ (Jasminæ), 249.
- Pitcher-like leaflets of *Staphylea pinnata*, 253.
- Pith in Pines, Causes which produce Eccentricity of, 761.
- Pits, Bordered, Mode of rendering visible the closing Membrane of, 315.
- Pittsburg, Microscopical Society of, 305.
- Piutti, A., and L. Luciani, Respiration of Silk-worm Ova, 726.
- Plane, Fungus Parasitic on, 631.
- Plant Analysis as an Applied Science, 89.
- Planta, A. v., Nutrient Food-Material of Bees, 942.
- Plant-cells, Properties and Changes of the Membrane, Protoplasm and Nucleus of, 980.
- — —, new method for Hardening and Staining, 1045.
- Plantago, Ovules of, 452.
- Plants, Preservation of, in Spirit and the Prevention of Browning, 852.
- which form their Rootlets without a Pocket, 987.
- Plasmodia, Fusion of Lymphatic Cells into, 555.
- Plasmodium of *Badhamia* and *Briefeldia*, 783.
- Plasmolysis in Flowering Plants, 759.
- of Algae, 93.
- Plasmolytic Method, New Application of, 1059.
- Plastic Reconstruction, Methods of, 853.
- Plastin and Nuclein, Demonstrating, 505.
- Plate, L., *Acinetoides*, 974.
- , *Asellicola digitata*, 973.
- , Organization of *Dentalium*, 933.
- Plate-cultivations, Hardening and Staining, 848.
- Plateau, F., Palpiform Organs of Crustacea, 413.
- , Powers of Vision, 32.
- , Respiration of Arachnida, 214.
- , Vision in Arachnids, 214.
- , — of Caterpillars and Adult Insects, 404.
- Platner, G., Karyokinesis in Lepidoptera, 571.
- , New Nuclear Stain and Note on Fixation, 675.
- Platyhelminthes. See Contents, xvi.
- Plaut, H., Improvement in Plaut's Flasks for sterilizing water, 1040.
- Plaut, H., Sterilization of Potato, Apples, and Water for cultivation purposes, 310.
- Pleochromism of coloured Cell-walls, 602.
- Pleospora, 469.
- Pleurocapsa, New, 784.
- Pleurosigma angulatum, Spectra of, 303.
- formosum, Structure of, 1063.
- Plitt, C., Anatomy of the Leaf-stalk, 448.
- Plössl's (S.) Focusing Arrangement, 651.
- Plovers' Eggs, Albumen of, as Nutrient Medium for Micro-organisms, 1037.
- Plum and Cherry-trees, Disease affecting, 274.
- Pocket-book, Histological, 686.
- Podocapsa, Ascomycetes and Oleina, New Genera of, 271.
- Podocarpus, Emergences on the Roots of, 252.
- Podura Scale, New Appearances in, 499.
- Poirier, J., New Human Distomum, 49.
- Poison of Hymenoptera, 425, 724.
- Polar Bodies in Ascaris, 43.
- Globule of Mammalian Ovum, 186.
- Globules in Animal Ova, Formation of, 705.
- Polarized Light, The use of the Microscope in the examination of Rock Sections by, 655.
- Polarizing Microscope, Dufet's, 107.
- Poli, A., Adaptation of Kaiser's gelatin for arranging microscopic preparations in rows, 680.
- , 304.
- Pollen-grains, Three Nuclei in, 440.
- Pollination and Distribution of the Sexual Organs, 612.
- in *Zannichellia palustris*, 256.
- of Alpine Plants, 454.
- of *Serapias*, 256.
- of *Silene inflata*, 454.
- Polychæta, Anatomy of, 41.
- Polyedriaceæ, 1013.
- Polygordius, 225.
- , Preparing, 662.
- Polymicroscope, Lenhossék's, 104.
- Polymorphism attributed to certain generio groups, 453.
- of the Hyphomycetes, 468.
- Polyparium, Nature of, 594.
- Polypides, Movements of, in Zoecia of Bryozoa, 936.
- Polypodaceæ, Development of the Sporangium of, 459.
- , Leaves of, 619.
- Polypody of Insect Embryos, 568.
- Polyporeæ, 1007.
- Polyporus abietinus, Fr., and *Irpex fusco-violaceus*, Fr., Identity of, 468.
- *applanatus*, Formation of two fertile hymenia in, 629.
- *biennis*, Conidiferous Form of, 778.
- Polyzoa. See Bryozoa, Contents, xi.
- Pond Dredging and Collecting, 505.
- Life, Illustrations of, 855.

- Pontederiaceæ, Apical meristem of the roots of, 248.
- Pontia brassicæ, Decrease of Weight in Winter Pupæ of, 572.
- 'Porcupine' Pennatulida, 745.
- Porifera. See Contents, xviii.
- Portehinski, —, Comparative Biology of Neoplaxons and Coprophagous Dip-terous Larvæ, 407.
- Post-embryonic Development of Julus, 213.
- Postal Microscopical Society, 503.
- Potamogeton, Colourless Oil-plastids in, 984.
- Potassium Hydrate, Permanent Preparations of Tissues treated with, 147.
- Potato, Apples, and Water for cultivation purposes, Sterilization of, 310.
- , Cultivation of Bacillus Tuberculosis on, 1038.
- Cultivations, 142, 143, 310, 311, 827.
- Fungus, 274.
- , Respiration of, 85.
- Potato-disease, New, 471.
- Potter, M. C., Alga epiphytic on a Tor-toise, 268.
- Potts, E., Collecting, Growing, and Ex-aminating Fresh-water Sponges, 305.
- , Fresh-water Sponges, 63.
- Poulton, E. B., Learning to see with the Microscope, 495.
- , Secretion of Pure Aqueous Formic Acid by Lepidopterous Larvæ for the Purposes of Defence, 405.
- Power and Harris, Manual for the Physi-ological Laboratory, 166.
- Praël, E., Protecting-wood and Duramen, 248, 761.
- Prenant, A., Preparing and Staining Mammalian Testicle, 844.
- , Spermatogenesis of Gastropods, 932.
- , — of Reptiles, 924.
- Preservation of Parts and Organs of Ani-mals, 658.
- President's Address, 177.
- Prickle-pores of Victoria regia, 81.
- Pricst, B. W., Remarkable Spicules from Oamaru Deposit, 967.
- Prillieux, E., Grape-disease — Comothyrium diplodiella, 98.
- Primitive Insects, 29.
- Streak and Medullary Canal, Relation of, 15.
- Pringsheim, N., Deposition of Calcareous Incrustations on Fresh-water Plants, 773.
- Prisms, Tri-ocular, Quadri-ocular, &c., 796.
- Pritchard's Microscope with "Continen-tal" Fine-adjustment, 1022.
- Problematical Organs of Invertebrata, 714.
- Procarp and Cystocarp of Gracilaria, 622.
- Propagula of Pinguicula, 764.
- Prosobranchs, Nervous System of, 21.
- Prostate Glands, So-called, of Oligochæta, 221.
- Protecting-wood and Duramen, 248, 761.
- Protein-granules, &c., Staining, 675.
- Prothallium of Equisetum, 262.
- Protoplasm, Membrane, and Nucleus of Plant-cells, Properties and Changes of, 980.
- Protista, Biological Studies on, 755.
- Protonema of Schistostega osmundacea, 774.
- Protophyta. See Contents, xxxvi.
- Protoplasm, Action of basic substances on living, 758.
- , Living, Transpiration as a Function of, 456.
- of Certain Cells, Contractility of, 457.
- — —, Power of Contractility exhibited by, 614.
- , Permeability of, 601.
- , Physiological Oxidation in, 454.
- , Reticulated, in the Interstitial Cells of the Ovary, 311.
- , Vesicular Elements of, in Protozoa, 748.
- Protoplasmic Movement, Influence of Light upon, 242.
- Prototracheata. See Contents, xiii.
- Protoremella, 1007.
- Protozoa. See Contents, xviii.
- Proulo, H., Researches on Dorooidaris papillata and other Mediterranean Echinids, 430.
- Pruvot, G., and H. de Lacaze-Duthiers, Larval Anal Eye in Opisthobranch Gastropods, 19.
- Prazmowski, A., Spore-formation in Bac-teria, 787.
- Pseudochlorophyll corpuscles in the vas-cular system of Lamellibranchs, 565.
- Psorospermium Haeckeli, 240, 598.
- Pteropoda. See Contents, x.
- Pteropods, Lamellibranchs and Gastropods, Ingestion of Water in, 199.
- Pterotrachea, Sucker on Fin of, 205.
- Puccinia Graminis, Structure and Life-history of, 1007.
- , New, 782.
- Pulfrich, C., A new refractometer, specially intended for the use of chemists, 495.
- Pulmonate Mollusca, Development of Heart of, 204.
- Pupæ and Surroundings, Colour-relation between, 727.
- Purification of Tolu Balsam for Micro-scopical Purposes, 681.
- Puteren, D. v., On the preparation of solid nutrient media for microbes from milk, 658.
- Pyrenomyces, New Genus of Sphæri-aceous, 630.
- Pyrenophora and Clathrospora, 631.
- Pyridin in Histological Technique, 1054.
- Pythium, New, 98.

## Q.

- Quadri-ocular, Tri-ocular, &c., Prisms, 796.  
 Quantitative estimation of Chlorophyll, 71.  
 Queen, J. W., Apparent and Actual Size of Field, Magnifying Power, &c., 501.  
 Quekett Club Journal and Microscopical Optics, 817, 1034.  
 Quélet, L., Ombrophila and Guepinia, 1008.  
 Quimby, B. F., Widening the Scope of Microscopical Societies, 503.  
 Quinn, E. P., Simple method of Projecting upon the screen Microscopic Rock Sections, both by ordinary and by polarized light, 819.  
 —, The Advantages and Deficiencies of the Lantern Microscope, 646.  
 —, The use of the Microscope in the examination of Rock Sections by Polarized Light, 655.

## R.

- Rabenhorst's 'Cryptogamic Flora of Germany' (Musci), 91.  
 Rabl-Rückhard, H., Peculiar Fat-cells, 928.  
 Radiolaria, 437.  
 Radulæ of small species of Gastropoda, Preparing, 507.  
 Raffaele, F., Eggs and Larvæ of Teleosteans, 925.  
 Rafter, G. W., Making Mounts Photographic, 854.  
 —, Photomicrographs, 813.  
 Rana temporaria, Fate of the Blastopore in, 925.  
 Raphides, Position and Number of, 445.  
 Raschke, E. W., Larva of Culex, 212.  
 Raskin, M., Milk as a Medium, 145, 656, 1038.  
 Rath, O. v., Dermal Sensory Organs of Insects, 210, 569.  
 Ráthay, E., New Vine-disease, 471.  
 Rattray, J., "A Monograph of the genus *Aulacodiscus*, 335, 337.  
 —, A Revision of the Genus *Auliscus* Ehrb. and of some allied Genera, 861.  
 —, Varieties of *Aulacodiscus*, 627.  
 Rauwenhoff, N. W. P., Sphæroplea, 267.  
 Rawitz, B., Green Gland of Crayfish, 216.  
 —, Mucous Cells in Mussels, 402.  
 Reading Microscopes, Hensoldt's, 640.  
 Red Chalk, The Foraminifera of, 383.  
 Redfern, J. J., Pal-Exner Method of Staining Sections of the Central Nervous System, 1057.  
 Reess, M., and C. Fisch, Elaphomyces, 273.  
 Reeves, J. E., Thin Sections, 1048.  
 Reeves's Method, 314.  
 — Water-bath and Oven, 163.  
 Reflector, Dreyfus's, with Ganz's Pinacroscope, 796.  
 —, Koch's and Max Wolz's, 1025.

- Refractometer, A new, specially intended for the use of chemists, 495.  
 —, Bertrand's, 291, 649.  
 Regeneration of Lost Parts, 215.  
 Regulator, Swift's, 649.  
 Reiche, K., Anatomy of the Floral Axis, 254.  
 Reichel, L., Formation of Byssus, 935.  
 Reichert, C., Cover-correction, 496.  
 —, Directions for using the Microscope, 141.  
 Reinherz, —, Testing Screw-Micrometers of Reading-Microscopes, 814.  
 Reinke, J., Oxidation-process in Plants after death, 88.  
 Reinsch, P. F., New Genera of Floridææ, 1002.  
 —, Polyedriacææ, 1013.  
 Rejuvenescence of Caulerpa, 464.  
 Relations of Structure and Function to Colour Changes in Spiders, 445.  
 Renal Organ of Echinoids, 590.  
 — Organs of Star-fishes, 958.  
 Renault, B., Leaves of Sigillaria and Lepidodendron, 263.  
 Rendle, A. B., Development of Aleurone-grains in the Lupin, 982.  
 —, Occurrence of Starch in the Onion, 983.  
 Repiachoff, W., Second Species of Turbellarian living on Nebalia, 428.  
 Replum in Crucifera, 611.  
 Reproduction of Phanerogamia. See Contents, xxiv.  
 Reproductive Organs and Oogenesis of Helix, 398.  
 Reptiles, Spermatogenesis of, 924.  
 Resegotti, L., and G. Martinotti, Demonstrating Karyokinetic Figures, 516.  
 —, Staining Karyokinetic Figures, 1050.  
 Reserve-substances in Evergreen Leaves, 983.  
 Respiration and Assimilation in Plants, 258.  
 —, Changes of Substance and Force connected with, 771.  
 — of Arachnida, 214.  
 — of Hydrophilus, 212.  
 — of Phanerogamia. See Contents, xxvi.  
 — of Silk-worm Ova, 726.  
 — of the Potato, 85.  
 — Relation between the Heat and the Carbonic Acid given off by Plants in, 455.  
 —, Sub-aquatic, 569.  
 Respiratory Organs (of Plants) 76.  
 Restiacea, Exoderm of the Root of, 987.  
 Reticulations in Vessels, 986.  
 Reticulum of Muscle-fibre, 928.  
 Retrogression in Oaks, 88.  
 Reuter, E., Basal Spot on Palps of Butterflies, 943.  
 Reynolds, R. N., A new Planisher, 515.  
 —, Reeves's Method, 314.  
 Rhamnus, Fruits and Seeds of, 78.

- Rhinanthem and Santalaceæ, Haustoria, of, 250.  
 —, Root-hairs of, 450.  
 Rhizome of Monocotyledons, Vascular Bundles in, 74.  
 Rhizomorpha subcorticalis of Armillaria mellea, 97.  
 Rhizopods, Digestion in, 240.  
 —, New, 757.  
 Rhododendron, Nectar of, 603.  
 Rhumbler, L., Various Cyst-formations and Developmental History of Colpoda, 969.  
 Richard, J., and J. de Guerne, Geographical Distribution of Diaptomus, 731.  
 Richter, —, Agar-agar for Cultivation, 1036.  
 — and Hauck's Phycotheca universalis, 627.  
 Ridley, H. N., Self-fertilization and Cleistogamy in Orchids, 994.  
 —, S. O., and A. Dendy, 'Challenger' Sponges, 597.  
 Riedlin, G., H. Buehner, and T. Longard, Method of calculating the Bacterial Increase, 682.  
 Rings, Annual, in Wood, Formation of, 75.  
 Rinnebock's Slides of Arranged Diatoms, 1057.  
 Ritzema Bos, J., Natural History of Tylenchus, 229, 585.  
 Robert, E., Spermatogenesis in Aplysia, 397.  
 Robertson, C., Fertilization of Calopogon parvillorus, 454.  
 —, Insect relations of Asclepiadeæ, 82.  
 Robin's, Lacaze-Duthiers', and Farabœuf's Injecting Syringes, 678.  
 Robinson, B. L., Taphrina, 274.  
 Rocks, Action of Lichens on, 95.  
 —, Disaggregation of, 315.  
 —, Microscopy and the Study of, 820.  
 Rodent's Blood, Hæmoglobin Crystals of, 198.  
 Rodewald, H., Changes of Substance and Force connected with Respiration, 771.  
 —, Relation between the Heat and the Carbonic Acid given off by Plants in Respiration, 455.  
 Roesser, P., and P. Gourret, Protozoa of Corsica, 755.  
 Rohde, E., Nervous System of Amphioxus, 390, 929.  
 Rolfe, R. A., Bigeneric Orchid Hybrids, 257.  
 Röhl, —, Forms of Sphagnum, 775.  
 Rolland, L., Blue Coloration of Fungi by Iodine, 628.  
 —, and J. Costantin, Styxanus and Hormodendron, 1010.  
 Romiti, G., Exhibition of a Microtome, 672.  
 Roosevelt, J. W., New Staining Fluid, 157.  
 Root of Caprifoliaceæ, Super-endodermal Network in, 73.  
 —, Diaphragms in the Air-canals of, 447.  
 — of Equisetum, Development of, 773.  
 — of Geraniaceæ, Sub-epidermal Network of, 986.  
 — of Leguminosæ and Ericaceæ, Super-endodermal Network of, 986.  
 — of Restiaceæ, Exoderm of, 987.  
 —, Supporting Network in the Cortex of, 986.  
 Root-absorption and the Growth of Plants, Influence of certain Rays of the Solar Spectrum on, 769.  
 —-hairs, Geminate, 251.  
 — —, New Method for Marking, 1015.  
 — of the Rhinanthem, 450.  
 —-pressure, 769.  
 —-symbiosis in the Ericaceæ, 86.  
 —-tubercles of Leguminosæ, 251.  
 —-tubes and Bacteria, 82.  
 Roots, Comparative Anatomy of, 75.  
 —, Floating, of Sesbania aculeata, 607.  
 — grown in Water, Action of Light on, 995.  
 — in Loranthaceæ, Formation of, 450.  
 —, Lateral, in Monocotyledons, Formation of, 762.  
 — of Araceæ, 607.  
 — of Compositæ, Oil-passages in, 447.  
 — —, Oil-receptacles in, 760.  
 — of Cycas, Anomalous Thickening in, 75.  
 — of Dicotyledons, Anomalies in the Structure of, 606.  
 — of Leguminosæ, Tubercles on, 608.  
 — of Papilionaceæ, Mycodomatia in, 450.  
 — of Podocarpus, Emergences on, 252.  
 — of Vicia Faba, Tubercular Swellings on, 251.  
 —, Secretion from, 246.  
 —, Structure of, and Arrangement of the Rootlets in Centrolepideæ, Ericaceæ, Junceæ, Mayaceæ, and Xyridæ, 251.  
 Rosaceæ, Embryo-sac of, 610.  
 —, Periderm of, 987.  
 Rosanilin Nitrate in watery Glycerin Solution, Staining with, 518.  
 Rose, J. N., and J. M. Coulter, Development of the Fruit of Umbellifereæ, 79.  
 Rose, Peronospora of, 1008.  
 Rosen, F., Mycological Notes, 784.  
 Rosenstadt, B., Structure of Asellus, 948.  
 Rosenthal, J., and O. Schulz, Alkali-Albuminate as a Nutrient Medium, 825.  
 Rosseter, T. B., "On the Generative Organs of Ostracoda," 168.  
 Rostrup, E., Fungi of Finland, 275.  
 Rotatoria, Chytridium elegans, n. sp., a Parasite of, 1011.  
 Rothert, W., Formation of Sporangia and Spores in the Saprolegniæ, 271.

- Rotifer, Parasitic, *Discopus Synaptae*, 52.  
 Rotifers, Contractile Vesicle of, 955.  
 Rotterer, E., Staining-differences of Un-  
 striped Muscle and Connective Tissue  
 Fibres, 843.  
 "Rouge" of the Scotch Fir, 781.  
 Roule, L., Formation of Embryonic Layers  
 and Coelom of a Limicolous Oligochaete,  
 735.  
 —, Histology of *Pachydrilus enchytrae-*  
*oides*, 222.  
 —, Killing contractile Animals in a  
 state of extension, 1044.  
 —, Striated Muscles in Mollusca, 402.  
 Roumeguère, C., Fungus Parasitic on the  
 Plane, 631.  
 Rousselet's (C.) Life-box, 112.  
 —, On a small Portable Binocular  
 Microscope and a Life-box, 110.  
 —, On some methods of Collecting and  
 Keeping Pond-life for the Microscope,  
 1040.  
 —, Pond Dredging and Collecting, 505.  
 Rouvier, L., Gas Chamber, 289.  
 —, Preparation and Staining of the  
 Spinal Cord, 660.  
 —, Technical Treatise on Histology,  
 686.  
 Roux, E., Colour-test for the detection of  
*Gonococcus*, 517.  
 —, Cultivation of Anaerobic Microbes,  
 1038.  
 —, On Potato cultivation, 311.  
 —, W., Embryonic Axis, 923.  
 Rowland's (W.) Reversible Compressorium,  
 803.  
 Royston - Pigott, G. W., Microscopical  
 Advances, 141, 305, 501, 652, 1036.  
 —, Villi on the Scales of Butterflies and  
 Moths, 498.  
 Roze, E., Pollination in *Zannichellia*  
*palustris*, 256.  
 Rücker, A. W., Micromillimetre, 502, 652.  
 Rudanowski, —, Microscopical Nerve Pre-  
 parations, 834.  
 Ruland, F., Antennary Sensory Organs of  
 Insects, 723.  
 Rumex, Ovules of, 764.  
 Ruminants, Protozoa found in the Stomach  
 of, 975.  
 Russian Lumbricidae, 581.  
 Russow, E., German Sphagnaceae, 621.  
 —, Physiological and Comparative  
 Anatomy of Sphagnaceae, 774.  
 Rutley, F., Rock-forming Minerals, 823.  
 Ryder, J. A., Celloidin-paraffin Methods  
 of Imbedding, 512.  
 —, Resemblance of Ovarian Ova and  
 the Primitive Foraminifera, 706.  
 —, and G. Feterolf, Vestiges of Zonary  
 Decidua in Mouse, 186.
- Sabatier, A., Spermatozoa of *Eledone*  
*moschata*, 560.  
 S. S.  
 Sablon. See Leclerc du Sablon.  
 Saccardo, P. A., New Genus of Sphaeri-  
 aceous Pyrenomyces, 630.  
 Saccharomyces, Cultivation of, 141.  
 — ellipsoideus and its Use in the Pre-  
 paration of Wine from Barley, 785.  
 — minor, 633.  
 Saeftigen, A., Nervous System of Phylac-  
 tolematous Fresh-water Bryozoa, 402.  
 Safranin and Anilin-blue, Modification of  
 Garbini's Double Stain, 1054.  
 — and Chromic Acid, Staining of Elastic  
 Fibres with, 1053.  
 — as a Stain for the Central Nervous  
 System, 1051.  
 St. Louis Club of Microscopists, 305.  
 Saint-Remy, G., Brain of *Iulus*, 408.  
 —, — of *Phalangida*, 576.  
 Salamander, Goblet-cells of Intestine of,  
 712.  
 —, Spermatogenesis of, 189.  
 Salensky, M., Development of Annelids,  
 218.  
 —, — of *Vermetus*, 201.  
 —, W., Lateral Organs, 587.  
 Salicorniæ, Foliar Sheath of, 609.  
 Salinity, Influence of, 60.  
 Salivary Glands of Cockroach, 725.  
 — of Insects, 211.  
 — of *Lech*, 38.  
 — of *Sepia officinalis* and *Patella*  
*vulgata*, 932.  
 Salomons, D., Note on Depth of Focus,  
 652.  
 Salpa, Histology of, 207.  
 Salsolæ, Anatomy of, 988.  
 Salt-excreting Glands of *Tamariscinæ*,  
 249.  
 — fish, Fungus Parasitic on, 781.  
 Sand-wasps, 30.  
 Sanderson, B., M. Foster, and Brunton,  
 Manual of the Physiological Laboratory,  
 686.  
 —, J. B., Electromotive Properties of  
 the Leaf of *Dionæa*, 995.  
 Sanfelice, F., Spermatogenesis in Guinea-  
 pig, 707.  
 —, — of Vertebrates, 523.  
 Sanford, E., Anatomy of the Common  
 Cedar-apple, 631.  
 Sanio, C., Hybrid Mosses, 264.  
 Santalacæ and *Rhinanthea*, *Haustoria*  
 of, 250.  
 Sap, Conduction of, through the Secondary  
 Wood, 768.  
 Saposhnikoff, W., Geotropism, 458.  
 Saprolegnia *ferax*, Infection of a Frog-  
 tadpole by, 272.  
 Saprolegniæ, Formation of Sporangia and  
 Spores in, 271.

- Saprolegnia, Recent Researches on, 1010.
- Sarasin, P. and E., Anatomy of Echinothuriada and Phylogeny of Echinodermata, 956.
- , Budding in Star-fishes, 233.
- , Development of *Helix Waltoni*, 21.
- , Gemmation in *Linekia multipora*, 431.
- , Longitudinal Muscles and Stewart's Organ in Echinothuriads, 429.
- , Renal Organ of Echinoids, 590.
- Sarcina of the Lungs, 634.
- Sarcolemma, 928.
- Sarcophila Wohlfartii, Larva of, in Gum of Man, 944.
- Sars, G. O., 'Challenger' Cumacea, 35.
- , —, Phyllocarida, 36.
- Sauvageau, C., Diaphragms in the Air-canal of the Root, 447.
- Savin, —, Influence of Exposure on the Formation of the Annual Rings in, 762.
- Scales of Butterflies and Moths, Villi on, 498.
- Secret-glands of Phryganidæ, 406.
- , —, organs of German Lepidoptera, 406.
- Schäfer's (E. A.) Hot-water Circulation Stage, and Swift's Regulator, 649.
- , R. P. C., Influence of the Turgidity of the Epidermal Cells on the Stomata, 605, 763.
- Schaffer, J., Staining in the Study of Bone Development, 844.
- Schanz, F., Fate of the Blastopore in Amphibians, 189.
- Scheuck, H., Anatomy of Water-plants, 77.
- Scheurle's Cancer Bacillus, 472, 785.
- Schewiakoff, W., Karyokinesis of *Euglypha*, 66.
- , and B. Grassi, *Megastoma entericum*, 599.
- Schieck's (F. W.) Meat-examining Microscope, 793.
- , Microscope Lamps, 490.
- , Travelling Microscope, 794.
- Schiffederdecker, P., Celloidin Corrosion Mass, Modification of, 159.
- , Microtome for Cutting under Alcohol, 152.
- , Structure of Nerve-fibre, 197.
- , Weigert's Hæmatoxylin Method as applied to other than Nervous Tissues, 674.
- Schiemenz, P., Ingestion of Water in Lamellibranchs, Gastropods, and Pteropods, 199.
- Schill, J. F., Læwenhoek's Discovery of Micro-organisms, 522.
- Schimmekewitsch, W., *Balanoglossus Mereschkovskii*, 588.
- , Development of Heart of Pulmonate Mollusca, 204.
- Schimmelbusch, C., A modification of Koch's plate process, 1010.
- Schimper, A. F. W., Formation of Oxalate of Lime in Leaves, 444.
- Schimper, A. F. W., Relationship between Ants and Plant in the Tropics, 772.
- , Starch and Chlorophyll-grains, 71.
- Schinzia, 631.
- Schistostega osmundacea, Protonema of, 774.
- Schizomycetes in coloured media, On the cultivation of, 115, 823.
- Schlagdenhauffen, F., and E. Heckel, Laticiferous product of *Mimusops* and *Paysona*, 759.
- Schmid, E., Sub-aquatic Respiration, 569.
- Schmidt and Haensch, The new improved enlarging camera of, 1034.
- , Zirconium Light for Photomicrography, 1033.
- , F., Development of Generative Organs of Cestoda, 426.
- Schneidemühl, —, Investigating the Effects of Remedies by the Microscope, 1060.
- Schneider, A., Sarcolemma, 928.
- Schnetzler, J. B., Colouring matter of the waters of the Lake of Bret, 785.
- , Infection of a Frog-tadpole by *Saprolegnia ferax*, 272.
- , Reproduction of *Thamniium alopecurum*, 773.
- , Tannin in *Acanthus spinosus*, 72.
- Schönland, S., Apical meristem of the roots of Pontederiacæ, 248.
- , Imbedding Plant Tissues, 511.
- , Modification of Pagan's "Growing Slide," 1028.
- Schottländer, F., Cell-division, 554.
- Schrenk, J., Vegetative Organs of *Brasenia peltata*, 449.
- Schröder, H., 503.
- Schroeter, J., Basidiomycetes, 1006.
- , Cohn's 'Cryptogamic Flora of Silesia' (Fungi), 99.
- Schuberg, A., Protozoa found in the Stomach of Ruminants, 975.
- Schultz, O., Physiological Anatomy of Stipules, 609.
- Schultze, F. E., A double lens made by Herr Westien of Rostock, 1025.
- , On a binocular dissecting lens, 1025.
- , O., Changes of Position of Nucleus, 390.
- , Segmentation in *Axolotl*, 392.
- , Vital Methylene-blue Reaction of Cell-granules, 842.
- Schulz, A., Pollination and Distribution of the Sexual Organs, 612.
- , E., Reserve-substances in Evergreen Leaves, 983.
- , O., and J. Rosenthal, Alkali-Albuminate as a Nutrient Medium, 825.
- Schulze, A., The new Apochromatic Micro-objectives and Compensating Oculars of Dr. Carl Zeiss, 1025.
- , F. E., 'Challenger' Hexactinellida, 597, 747.

- Schulze, H., Vegetative reproduction of a Moss, 91.
- , O., Preparing Ova of Amphibia, 146.
- Schumann, K., Comparative Morphology of the Flower, 451.
- , Morphology of the Flowers of *Canna*, 611.
- New Myrmecophilous Plants, 998.
- Schütt, F., *Chætoceros*, 627.
- , Formation of Auxospores in Diatoms, 268.
- , Phycocerythrin, 622.
- , Phycophæin, 265.
- , Spore-formation in Peridineæ, 437.
- Schwabe's Sliding Microtome, 668.
- Schwarz, C. G., So-called Mucous Gland of Male Cypridæ, 731.
- Schwerdoff, —, Method of investigation for the earlier stages of the development of Mammalian ova, 511.
- Schwinck, —, Gastrula of Amphibians, 549.
- Sclater, W. L., Development of a South American *Peripatus*, 410.
- Scorpions, Eyes in, 411.
- Scotch Fir, "Rouge" of, 781.
- Scott, D. H., Floating-roots of *Lesbania aculeata*, 607.
- , Nucleus in *Oscillaria* and *Tolyptothrix*, 275.
- , G. P., Exhibition of a Microscope, 485.
- , W. B., Development of *Petromyzon*, 388.
- Screen for the Abbe Camera Lucida, 809.
- Scyphistomata of *Acraspedote Medusæ*, 965.
- Seaman, W. H., American and Foreign Microscopes, 797.
- , Lamp and Vertical Illuminator, 650.
- , Myrtle-wax Imbedding Process, 151.
- , Shellac Cement, 529.
- Sea-water, Phosphorescent Bacteria from, 101.
- Secreting Canals of Umbelliferæ and Araliacæ contained in the Phloem, 605.
- Cells of Intestinal Epithelium, 556.
- Secretion of Pure Aqueous Formic Acid by Lepidopterous Larvæ for the Purposes of Defence, 405.
- , Organs of, 77.
- Secretions, Development of some, and their Receptacles, 604.
- Secretory Canals and Reservoirs, 604.
- of *Araucaria*, 986.
- Section-cutting. See Contents, xxxviii.
- Sections, Fixing, 159, 853.
- , Nerve, Half-clearing method of preparing, 680.
- Sedgwick, A., Development of the Cape Species of *Peripatus*, 409.
- , Monograph of the Genus *Peripatus*, 576.
- Seed of *Myristica surinamensis*, Aleurone-grains in, 72.
- Seeds and Fruits, Motion of rotating Winged, 612.
- — — of *Rhamnus*, 78.
- of *Pharbitis triloba*, 764.
- with Two Integuments, 992.
- Segmental Organs and Efferent Ducts of genital glands, homology of, in Oligochaeta, 419.
- Segmentation and Fertilization in *Ascaris megalocephala*, 423.
- in *Axolotl*, 392.
- of Teleostean Ova, 191.
- , Primary of the Germ-stripe of Insects, 941.
- Seifert, O., *Ankylostomum duodenale*, 739.
- , On the Auer incandescent gas-burner, 495.
- Selaginella lepidophylla, 620.
- , Stomata and Ligules of, 460.
- Selection and Elimination, 927.
- Selenka, E., Models in Metal of Microscopical Preparations, 165.
- Self-fertilization and Cleistogamy in Orchids, 994.
- — — and Heterostylism, 453.
- — — pollination of *Spergularia salina*, 994.
- Selvatico, S., Aorta of *Bombyx mori*, 212.
- Semon, R., Mediterranean Synaptidæ, 233.
- Senecioidæ and Ambrosiaceæ, Comparative Anatomy of, 449.
- Sense of Direction in *Formica rufa*, 212.
- Senses, Curiousities of, 500.
- of Ants, 571.
- Sensibility to Heat, Apparatus for determining, 114.
- Sensory Organ, Dermal, of Insects, 569.
- Organs and Nerve-centres of *Articulata*, 403.
- — —, Antennary, of Insects, 723.
- — — of Insects, Dermal, 210.
- Sepia officinalis* and *Patella vulgata*, Salivary Glands of, 932.
- Septal Glands of *Narcissus*, formation of Sugars in, 759.
- Serapias, Pollination of, 256.
- Serial Sections, The Mounting of, 682.
- Serpula, Structure of, 42.
- Sertoli, E., and V. v. Ebner, Spermatogenesis of Mammals, 707.
- Serum, Artificial, for Computation of Blood-corpuscles, 162.
- Sesbania aculeata*, Floating-roots of, 607.
- Sex, Production of, and phenomena of Crossing, 256.
- Sex-cells and Development of *Millepora*, 236.
- Sexual Dimorphism in Amphipoda, 949.
- Organs in *Æcidium*, 782.
- — —, Pollination and Distribution of, 612.
- — — Reproduction, Significance of, 193.
- Sexuality of *Ustilaginæ*, 269.

- Seymour, A. B., Character of the Injuries produced by Parasitic Fungi upon their Host-plants, 470.
- Seynes, J. de, Ceriomyces and Fibrillaria, 630.
- , Fungus Parasitic on the Pine-apple, 780.
- , Polyporæ, 1007.
- , Rhizomorpha subcorticalis of Armillaria mellea, 97.
- Sharp, B., Phylogeny of Lamellibranchs, 565.
- Sheldon, L., Anatomy of Peripatus capensis and P. novæ Zealandiæ, 577.
- , Development of Peripatus Novæ Zealandiæ, 33.
- Shellac Cement, 520.
- Shell-growth in Cephalopoda, 397, 559.
- Shells, Growth of Cephalopod, 200.
- Sherborn, C. D., H. W. Burrows, and G. Bailey, The Foraminifera of the Red Chalk, 383.
- Bibliography of the Foraminifera, 757.
- Shrew, Inversion of the Germinal Layers in, 706.
- Sidebotham, H., Fate of the Blastopore in Rana temporaria, 925.
- Sieve-tubes in the Laminariæ, 265.
- Sigillaria and Lepidodendron, Leaves of, 263.
- Silene inflata, Pollination of, 454.
- Siliceous Sponges, Natural History of, 745.
- Silicispngiæ, Gemmules of, 596.
- Silicoblasts, 596.
- Silk-worm, New Parasite of, 471.
- — — Ova, Respiration of, 726.
- Silver, Quantitative Determination of, by means of the Microscope, 494.
- , separation of, by active Albumin, 244.
- Silver-nitrate, Method for staining Nervous Tissue, Improvements in, 844.
- Simmons, W. J., Magnification in Photomicrographs, 652.
- Simonelli, V., Structure of Serpula, 42.
- Siphonæ, Staining Membranes in Living, 516.
- Siphonophora, Morphology of, 59.
- , System of, 741.
- Skeleton of Calcareous Sponges, 63.
- Skin, Staining the Elastic Fibres of, 155.
- Slide, Capillary, and accessories for the examination of Ova, 801.
- , Fixing Sections to, 159, 853.
- for observing Soap-bubble Films, 647.
- , Hardy's Growing, 489.
- , Holman's Current, 806.
- , Modification of Pagan's "Growing, 1028.
- , Preparing, to show Brownian Movement, 833.
- Slides, Life, 804, 806.
- Sliding Microtome, Schwabe's, 668.
- Sloth, Algæ parasitic on, 624.
- Sluiter, C. P., Remarkable Case of Mutualism, 557.
- Smart, C., Gelatin Culture Test for Microorganisms of Water, 855.
- Smiley, C. W., Rinnbock's Slide of arranged Diatoms, 1057.
- Smith, E. A., Abnormal Growth in Haliotis, 561.
- , G., Nelson's Photomicrographic Focusing Screen, 119.
- , J. A., New Chromogenic Bacillus—Bacillus coruleus, 472.
- , J., Substance containing Sulphur in Cruciferous Plants, 997.
- , L. H., Memoir of D. S. Kellicott, Pres. Amer. Soc. Micr., 305.
- , T., The Microscope in the Study of Bacteriology, 324.
- , T. F., Arachnidiscus as a new Test for High-power Objectives, 815.
- , Finer Structure of Butterfly Scales, 405.
- , New Appearances in Podura Scale, 499.
- , On True versus False Images in Microscopy, 819.
- , Some points in Diatom-structure, 94.
- , Structure of Pleurosigma formosum, 1063.
- , Villi on the Scales of Butterflies and Moths, 498.
- Smalls, Effects of Lesion of Supra-oesophageal Ganglia in, 717.
- Soap-bubble Films, Slide for observing, 647.
- Society Screw, 486.
- Soil and Water, New and Typical Microorganisms from, 789.
- Solanaceæ, Fruit of, 611.
- Solar Spectrum, Influence of certain Rays of, on Root-absorption and on the Growth of Plants, 769.
- Solereder, —, Systematic Value of the Perforation in the Walls of Vessels, 447.
- Sollas, W. J., Sponges, 62.
- Solms-Laubach's (H. v.) Introduction to Fossil Botany, 620.
- Somomya, Brain of, 944.
- erythrocephala, Organization of Brain of, 407.
- Sonntag, P., Duration of the Apical Growth of the Leaf, 455.
- Sorauer, P., Root-tubers and Bacteria, 82.
- Soulier, A., Formation of Tube of Annelids, 418.
- Souza, A. de, On pyridin in Histology, 519, 1054.
- Soyka, J., Bacteriological investigation methods, with special reference to quantitative, 1040.
- Sparganium and Typha, Flowers and Fruit of, 78.
- Spæcia of Pleurosigma angulatum, 303.

- Spergularia salina*, Self-pollination of, 991.
- “Spermata” of the Ascomycetes, 1006.
- Spermatogenesis, 16, 27.
- in *Alyconella*, 566.
- in *Aplysia*, 397.
- in *Chætognatha*, 227.
- in Guinea-pig, 707.
- of Arthropods, 940.
- of Gastropods, 932.
- of Mammals, 547, 707.
- of Marsupials, 386.
- of Reptiles, 924.
- of Salamander, 189.
- of Vertebrates, 923.
- Spermatozoa and Ova, Formation of, in *Spongilla fluviatilis*, 966.
- from Triton, 1065.
- in *Murex*, Form and Development of, 200.
- of *Eledone moschata*, 560.
- of Frog, Irritability of, 707.
- Sphærocrystals, 603.
- Sphæroplea, 267.
- Sphærozoa, Preparing, 665.
- Sphagna, New, 91.
- Sphagnaceæ, German, 621.
- , Physiological and Comparative Anatomy of, 774.
- Sphagnum and *Andræa*, Sporogonium of, 91, 1000.
- , Forms of, 775.
- Spherometer Microscope, Bamberg’s, 280.
- Sphyranura, Methods of studying, 149.
- osleri, 47.
- Spicules, Remarkable, from the Oamaru Deposit, 967.
- Spider, New Orb-weaving, 412.
- Spillmann, —, and Haushalter, —, Dis-semination of *Bacillus* by Flies, 635.
- Spinal Cord, Effect of Hardening Agents on the Ganglion-cells of, 831.
- — —, Preparation and Staining of, 660.
- Ganglion-cells, 556.
- Spines, Anatomy of, 763.
- of certain Plants, 989.
- Spinther, Annelid Genus, 42.
- Spirillum concentricum*, a new species from decomposing blood, 278.
- Spirochæte of Relapsing Fever, Staining, 1054.
- Spirogyra, Conjugation of, 625.
- Spleen, Injection Mass for the Vessels of, 848.
- Sponges. See *Porifera*, Contents, xviii.
- Spongilla*, Development of Generative Products in, 61.
- *fluviatilis*, Formation of Ova and Spermatazoa in, 966.
- , Investigation of Generative Products of, 1045.
- Spongillæ*, Survival of, after Development of Swarm-larvæ, 596.
- Spongoeccladia*, 1002.
- Sporangia and Spores in the *Saprolegniæ*, Formation of, 271.
- Sporangium of Ferns, Dehiscence of, 90.
- of *Polypodiaceæ*, Development of, 459.
- Spore-formation in Bacteria, 787.
- — — in *Peridnieæ*, 437.
- — — in the *Bacilli* of *Xerosis conjunctivæ*, *Streptococci*, and *Cholera spirilla*, 1016.
- — — in the *Bacillus* of Glanders, 473.
- Spores and Sporangia in the *Saprolegniæ*, Formation of, 271.
- , Germination of, in *Ustilago*, 270.
- of *Equisetum*, Dissemination of, 1000.
- of the Ferments, 633.
- , Staining, 845.
- Sporogonium of *Andræa* and *Sphagnum*, Development of, 91, 1000.
- of Mosses, Anatomy and Development of, 460.
- Sporophore of Mosses, Transpiration of, 91.
- Spring-sap in the Birch and Hornbeam, 445.
- Stage, Babes’ Hot, 800.
- , Edmonds’s Automatic Mica, 111, 171.
- , Fine-adjustment by Tilting, 478.
- , Malassez’s Hot, 483.
- , Nelson’s Mechanical, 477.
- , new form of mechanical, 334.
- , Schäfer’s Hot-water Circulation, 649.
- Staining. See Contents, xxxviii.
- Stamati, G., Castration of the Cray-fish, 947.
- , Digestion in Cray-fishes, 947.
- Stamens of *Echinocactus*, Irritability of, 261.
- Standards of Length and their practical application, 503.
- Stapf, O., Explosive Fruits of *Alstroëmeria*, 255.
- Staphylea pinnata*, Pitcher-like Leaflets of, 253.
- Star-fish, Emigration of Amoeboid Corpuscles in, 431.
- -fishes, Budding in, 233.
- - —, Renal Organs of, 958.
- Starch, Action of Formose on Cells destitute of, 85.
- and Chlorophyll-grains, 70.
- , Formation of, from various substances, 771.
- , — of, in the Chlorophyll-grains, 71, 983.
- , Injection-mass, 1056.
- , Occurrence of, in the Onion, 983.
- Starch-grains, Structure of, 443.
- Stedman, J. M., Preparing Tape-worms for the Museum and the Microscope, 148.
- Stegemann’s (A.) Photomicrographic Camera, 116.

- Stein's (S. T.) "Large Photomicroscope," 295.
- Steinach's (E.) Filter-capsule, 850.
- Steiner, —, Physiology of Nervous System, 559.
- Steinhaus, J., Goblet-cells of Intestine of Salamander, 712.
- Stems, Aerial, 451.
- , Torsion of, 989.
- , Underground, Morphology of, 450.
- Stenglein, M., Course and Fine Focusing Arrangements, 1032.
- , Illumination of Objects in Photomicrography, 1033.
- , Instantaneous Photomicrography, 811.
- , and O. Israel's Photomicrographic Microscope, 115.
- Sterculiaceæ, &c., Comparative Anatomy of, 606.
- Sterile Fronds, Conversion of Fertile into, 261.
- Sterility of Fungi, 467.
- Sterilization of Potato, Apples, and Water for cultivation purposes, 310.
- Sterilizing water, Improvement in Plaut's Flasks for, 1040.
- Sternberg, G. M., Photomicrography in Medicine, 119.
- Stewart, C., Exhibition of remarkable form of Lamellibranch Shell (*Thecalia*), 170.
- Stewart's Organ and Longitudinal Muscles in Echinothurids, 429.
- Stichococcus and Ulothrix, 777.
- bacillaris, 632.
- Stipules, 252.
- , Physiological Anatomy of, 609.
- Stizenberger, —, and Hegetschweiler, —, Lichens on unusual substrata, 96.
- Stöhr, P., Handbook of Histology and Human Microscopical Anatomy, including Microscopical Technique, 686.
- Stokes, A. C., Fresh-water Infusoria of the United States, 598.
- , Life Slides, 806.
- , New Fresh-water Infusoria, 65.
- , Notices of New Infusoria Flagellata from American Fresh Waters, 698.
- , Two new Aquatic Worms from North America, 582.
- Stomaeh, Glandular Cells of, 393.
- of Ruminants, Protozœa found in, 975.
- , So-called Digestive, of some Ants, 570.
- Stomata and Ligules of Selaginella, 460.
- , Development of, 247.
- , Influence of the Turgidity of the Epidermal Cells on, 605, 763.
- Stone, W. E., Cultivation of Saccharomyces, 141.
- Stowell, C. H., Thin Sections, 812.
- Strasburger, E., Division of the Nucleus, Cell-division, and Impregnation, 600, 978.
- Strasburger, E., Microscopic Botany. A Manual of the Microscope in Vegetable Histology, 166.
- Strasser, H., Methods of Plastic Reconstruction, 853.
- , New Section-stretcher, with arrangements for removing the Section, 841.
- , and W. His, On the methods of Plastic Reconstruction and their importance for Anatomy and Embryology, 686.
- Straus, —, and Wurtz, —, Improved method for the Bacteriological Examination of Air, 854.
- Strecker's Gas Chamber, 288.
- Streptococci, &c., Spore-formation in, 1016.
- Streng, A., On some microchemical reactions, 856.
- Stricker, S., Electric Microscope, 1025.
- Stricker's Gas Chamber, 288.
- Stroemfelt, H. F. G., Attachment-organ of Algae, 461.
- , New Genera of Phæozoopores, 465.
- Strubel, A., Structure and Development of *Heterodera Schachtii*, 737.
- Struthiopteris germanica, Willd., Development of, 618.
- 'Student's Handbook to the Microscope,' 137.
- Studer, T., Classification of Aleyonaria, 237.
- Studies in Vegetable Biology, 996.
- Sturt, G., and E. Grove, Fossil Marine Diatoms from New Zealand, 94.
- Styrax Balsam, Preparing, 1057.
- Styranus and Homodendron, 1010.
- Sub-aquatic Respiration, 569.
- epidermal Network of the Root of Geraniaceæ, 986.
- stage, Necessity for a, 1024.
- Suberites, Structure of, 239.
- Suberosus Cells, Wall of, 985.
- Sublimate as a Hardening Medium for the Brain, 831.
- Subterranean Shoots of Oxalis, 988.
- Sucker on Fin of *Pterotrachea*, 205.
- Suckers in Phanerogamous Parasites, Origin of, 80.
- Sugar and Alkaloid in Cyclamen, 759.
- of Milk, Occurrence of the Elements of, in Plants, 604.
- Sugars in the Septal Glands of *Narcissus*, Formation of, 759.
- Sulphur in Cruciferous Plants, Substance containing, 997.
- Super-endodermal Network in the Root of the Caprifoliaceæ, 73.
- — — — of the Root of Leguminosæ and Ericaceæ, 986.
- Sutroa rostrata, New Annelid, 582.
- Swaen, A., Development of *Torpedo ocellata*, 389.
- Swarm-larvæ, Survival of Spongillæ after Development of, 596.
- Sweden, "New Glass just made in, 499.
- Swift, J., The Jena Optical Glass, 486.
- Regulator, 649.

- Sycon, Sections of, 690.  
 Sydow's (P.) Lichens of Germany, 621.  
 Symbiosis of Bacteria with *Gloeocapsa polydermatica*, 634.  
 —, Role of, in Luminous Marine Animals 929.  
 —, Root-, in the Ericaceæ, 86.  
 Symbiotic Fungus in Molgulidæ, 782.  
 Symphoricarpos, Floral Nectary of, 255.  
 Synaptidæ, Mediterranean, 233.  
 Synthesis of Albuminoids, 455.  
 Syringes, Robin's, Lacaze-Duthiers', and Farabœut's Injecting, 678.
- T.
- "T. F. S.," "Microscopical Advances," 137.  
*Tænia cucumerina* in Man, 955.  
 — *elliptica* and *Ascaris lumbricoides*, Life-history of, 426.  
 — *nana*, 46, 229.  
 — *saginata*, 955.  
 — —, Interesting Specimen of, 427.  
 Taguchi, K., Injection with Indian Ink, 848.  
*Tamariscinæ*, Salt-excreting Glands of, 249.  
*Tanaidæ* and the *Apsedes*, 416.  
 Tanakadate, A., Note on the Constants of a Lens, 819.  
 Tange, F., Cell-division, 18.  
 Tannin and its connection with Metastasis, 984.  
 —, Function of, 444.  
 — in *Acanthus spinosus*, 72.  
 — in the *Crassulaceæ*, 603.  
 Tänzer, P., On Unna's staining method for the elastic fibres of the skin, 850.  
 Tape-worm, Methods of preparing, 511.  
 — -worms for the Museum and the Microscope, Preparing, 148.  
 — —, Mounting, 314.  
*Taphrina*, 274, 470.  
*Tarantula*, American, Age and Habits of, 215.  
 Tarchanoff, J., and Kolessnikoff, —, Alkaline Egg-albumen as a Medium for Bacteria Cultivation, 503.  
 Tassi, F., Nectar of *Rhododendron*, 603.  
 Tate, A. W., Use of the Microscope for practical purposes, 324.  
 Tavel, F. v., Mechanical Protection of Bulbs, 607.  
 Taylor, T., Crystalline formations of Lard and other Fats, 166, 324.  
 —, Wax-cells, 519.  
 Teasing-needle, James's, 520.  
 Teeth and Bone, Method for making Preparations of, and retaining their soft parts, 1042.  
 Tegumentary Filaments of Flagellata, Method of Preparing, 832.  
 Teleostean Ova, Segmentation of, 191.  
 Teleosteans, Eggs and Larvæ of, 191, 925.  
 Teleostei, Germinal Layers in, 189.  
 —, Origin of Blood in, 192.  
 Telescope and Microscope, 820.  
 Telphusa, Parasite of, 40.  
 Temnocephala, 50.  
 Tempère's (J.) Preparations of Diatoms, 667.  
*Teredo navalis*, Parasites of, 199.  
 Testacella, 562.  
 Test, Arachnoidiscus as a new, for High-power Objectives, 815.  
 Test-plates, Fasoldt's, 298, 817.  
 — -tube Cultivations, Preparing Sections from, 671, 833.  
 — -tubes, Fire-proof Cotton-wool Plug for, 1040.  
 Testicle, Mammalian, Preparing and Staining, 844.  
 —, Preparing, for observing Nuclear Fission, 146.  
 Tests for Callus, Microchemical, 323.  
 — for Modern Objectives, 816.  
 Tetraedron and Trochisci, 1013.  
 Thallophtyes in Medicinal Solutions, 459.  
 Thallus of certain Algæ, Development of, 265.  
 — of *Marchantiæ*, Hygroscopic Movements of, 1001.  
*Thamnum alopecurum*, Reproduction of, 773.  
 Thanhoffer, L. v., Two new Methods for preparing Nerve-cells, 658.  
 Thate's (P.) New Microtome, 839.  
 Thaxter, R., Entomophthoræ of the United States, 1010.  
 Thecalia, Shell of, 170.  
 Thermic Experiments on *Periplaneta orientalis*, 31.  
 Thickness, Proper, of Microscopical Sections, 671.  
 Thistle-flower, Trigger-hairs of, 452.  
 Thoma Microtome, Accessory for rapid Cutting with, 840.  
 Thompson, J. C., New Parasitic Copepod, 417.  
 Thomson, J. A., Action of the Environment, 927.  
 —, Structure of *Suberites*, 239.  
 Thümen, F. v., Fungi of Fruit-trees, 780.  
 —, New Vine-disease, 471.  
 Thury's Five-tube Microscope, 792.  
 Thyllæ, 988.  
 Tichomiroff, A., Parthenogenesis in *Bombyx mori*, 725.  
 Tieghem, P. v., Arrangement of Secondary Roots and Buds on Roots, 80.  
 —, Exoderm of the *Restiaceæ*, 987.  
 —, Geminate Root-hairs, 251.  
 —, New Genera of *Ascomycetes*, *Oleina*, and *Podocypsa*, 271.  
 —, Structure of the root and arrangement of the rootlets in *Centrolepidæ*, *Ericaceæ*, *Juncæ*, *Mayaceæ*, and *Xyridæ*, 251.

- Tieghe, P. v., Super-endodermal Network of the Root of Leguminosæ and Ericaceæ, 986.  
 —, ——— in the Root of the Caprifoliaceæ, 73.  
 —, Supporting Network in the Cortex of the Root, 986.  
 —, Tubercles on the Roots of Leguminosæ, 608.  
 — and H. Douliot, Plants which form their Rootlets without a Pocket, 987.  
 — and Monal, —, Sub-epidermal Network of the Root of Geraniaceæ, 986.  
 Tiemann, F., 686.  
 Tiliacæ, &c., Comparative Anatomy of, 606.  
 Tindall, S. J., Seales on Red Currants, 856.  
 Tintinnosæ, Monograph of, 436.  
 Tissue of Fossil Plants, Anomalous Cells in the Interior of, 605.  
 Tissues and Cells, 710.  
 — and Ova, Bacteria-like Bodies in, 31.  
 —, Imbedding Plant-, 511.  
 —, Methods of Fixing and Preserving Animal, 510.  
 — of Living Animals, Differential Staining of, 842.  
 Tolu Balsam for Microscopical Purposes, Purification of, 681.  
 Tolypothrix and Oscillaria, Nucleus in, 275.  
 Tomaschek, A., Bacillus muralis, 276, 786.  
 —, New Chytridium, 1011.  
 —, Symbiosis of Bacteria with Gloecapsa polydermatia, 634.  
 Tombs, Fauna of, 32.  
 Toni, J. B. de, Bulbotrichia, 1003.  
 —, Classification of Chlorophyceæ, 775.  
 —, Diatoms from a Trygon, 777.  
 —, Hlansgirgia, a new genus of aerial Algæ, 1003.  
 —, Remarkable Flos-aquæ, 633.  
 Toppent, E., Gemmules of Silicispongiæ, 596.  
 —, So-called Peripheral Prolongations of Clonæ, 239.  
 Torpedo ocellata, Development of, 389.  
 Torsion of Stems, 989.  
 Tortoise, Alga epiphytic on, 268.  
 Transpiration as a Function of Living Protoplasm, 456.  
 —, Influence of Atmospheric Movement on, 259.  
 —, Literature of, 259.  
 — of the Sporophore of Mosses, 91.  
 Trapella, Oliv., a new Genus of Pedalineeæ, 992.  
 Trautwein, J., Anatomy of Annual Branches and Inflorescences, 451.  
 Treasurer's Account for 1887, 331  
 Trees, Acarida on, 34.  
 —, Effects produced by the Annular Decortication of, 447.  
 Trelease, W., Subterranean Shoots of Oxalis, 988.  
 Trematoda, General Sketch of, 953.  
 Trematode in white of newly-laid Hen's Egg, 51.  
 Tremella fimetaria, 270.  
 Trentepohlia, 777.  
 Treub, M., Life-history of Lycopodium, 262.  
 —, Myrmecophilous Plants, 998.  
 Trichinæ or other Animal Parasites in Meat, Determination of the Number of, 164.  
 Trichocladium, Development and Fructification of, 630.  
 Trichomanes, Formation of Gemmæ in, 262.  
 —, Oophyte of, 617.  
 Trichosphaeria paradoxa and Herpotrichia nigra, 470.  
 Tricladæ, Some European, 229.  
 Tridacna, So-called Eyes of, &c., 564.  
 Triebel, R., Oil-passages in the Roots of Composite, 447, 760.  
 Trigger-hairs of the Thistle-flower, 452.  
 Tri-ocular, Quadri-ocular, &c., Prisms, 796.  
 Triple-staining, Baumgarten's Method of, 676.  
 Triton, Spermatozoa from, 1065.  
 Trochiscia and Tetraedron, 1013.  
 Troup, F., The Diagnosis of early Phthisis by the Microscope, 856.  
 Truan, A., and O. Witt, Photomicrographs of Diatoms, 295.  
 Truffle, Parasitism of, 780.  
 Trygon, Diatoms from a, 777.  
 Trzebinski, S., Effect of Hardening Agents on the Ganglion-cells of the Spinal Cord, 831.  
 Tschireh, A., Aleurone-grains in the Seed of Myristica surinamensis, 72.  
 —, Contents of the Cells of the Aril of the Nutmeg, 760.  
 — Development of some Secretions and their Receptacles, 604.  
 —, Organs of Secretion, 77.  
 —, Quantitative estimation of Chlorophyll, 71.  
 Tube of Annelids, Formation of, 418.  
 Tubercle and Lepra Bacilli, Staining, 157, 846.  
 — Bacillus Stain, Specificness of, 157.  
 — —, Simple and Rapid Staining of, 1053.  
 Tubercles on the Roots of Leguminosæ, 608.  
 Tubercular Swellings on the Roots of Vicia Faba, 251.  
 Tubercularia, New, 779.  
 Tubes for Microspectroscopic Analysis, 807.  
 Tubeuf, C. v., Formation of Roots in Loranthaceæ, 450.  
 —, New Disease of the Douglas-pine, 471.  
 Tubular Cells of the Fumariaceæ, 73.  
 Tuckerman, F., Tænia saginata, 427, 955.

- Tunicata. See Contents, xi.  
 Turbellarian, Second Species of, Living on  
 Nebaliae, 428.  
 Tylenchus devastatrix, 585.  
 —, Natural History of, 229.  
 Typha and Sparganium, Flowers and Fruit  
 of, 78.  
 Typhoid Bacillus, Supposed Spores of,  
 1016.  
 "Typhus" Bacillus, Cultivation of, in  
 coloured nutrient media, 1039.

## U.

- Uhlitzsch, P. G., Growth of the Leaf-stalk,  
 258.  
 Ulothrix, 465.  
 — and Stichococcus, 777.  
 — crenulata, 268.  
 —, Structure of, 1003.  
 Ulotrichaceæ, Aerophytic Species of,  
 1002.  
 Umbelliferæ and Araliaceæ, Secreting  
 Canals of, contained in the Phloem, 605.  
 —, Development of the Fruit of, 79.  
 Underground Stems, Morphology of, 450.  
 Underhill, H. M. J., Section-cutting applied  
 to Insects, 152.  
 Ungar, —, On staining Spermatozoa, 850.  
 United States, Entomophthoræ of, 1010.  
 — —, Fresh-water Infusoria of, 498.  
 — —, Wolle's Fresh-water Algæ of,  
 94.  
 Unna, P. G., The cultivation of Skin fungi,  
 831.  
 Upson, H. S., Carmine staining for nerve-  
 tissue, 850.  
 Urceolaria, Structure of, 753.  
 Urech, F., Decrease of Weight in Winter  
 Pupæ of *Pontia brassicæ*, 572.  
 —, Diminution in Weight of Chrysalis,  
 31.  
 Uredineæ, 97.  
 — and their Hosts, 1007.  
 Urine, Stain for the Morphological Ele-  
 ments in, 845.  
 Urochæta, Mucous Gland of, 422.  
 Uronema, a new genus of Chlorozooporeæ,  
 626.  
 Uruguay, New Species of, 748.  
 Uskow, N., Development of Blood-vascular  
 System of the Chick, 187.  
 Ustilagineæ, Sexuality of, 269.  
 Ustilago, Germination of the Spores in,  
 270.

## V.

- Vacuole, Nature of Contractile, 749.  
 Vacuoles, Increase of Normal, by Division,  
 981.  
 Vaizey, J. R., Absorption of Water and its  
 Relation to the Constitution of the Cell-  
 wall in Mosses, 263.  
 —, Alternation of Generations in Green  
 Plants, 459.

- Vaizey, J. R., Anatomy and Development  
 of the Sporogonium of Mosses, 460.  
 — Development of the Root of *Equi-  
 setum*, 773.  
 — Transpiration of the Sporophore of  
 Mosses, 91.  
 Vallentin, R., and J. T. Cunningham,  
 Photospheria of *Nyctiphanes norvegica*,  
 415.  
 Valvata piscinalis, Anatomy of, 718.  
 Van Gieson, J., A résumé of recent  
 Technical Methods for the Nervous  
 System, 511.  
 Varalda, L., and E. Perroncito, Composi-  
 tion of "Muffe," 633.  
 Vascular System and Cœlom of Mollusca  
 and Arthropoda, 395.  
 — Apparatus and Nervous System of  
 Ophiurids, 57.  
 — Bundles in the Rhizome of Mono-  
 cotyledons, 74.  
 — System of Hirudinea, 219.  
 Vassale, G., and G. Bizzozero, Staining  
 Mitoses, 674.  
 Vayssière, A., Systematic Position of *Hero*,  
 718.  
 Vegetable Biology, Studies in, 996.  
 Vegetative reproduction of a Moss, 91.  
 Veitch, H. J., Fertilization of *Cattleya  
 labiata*, 994.  
 Vejdovsky, F., Larval and Definite Excre-  
 tory Systems in Lumbricidæ, 220.  
 —, Studies on Gordiidæ, 583.  
 Venetian Chlorophyceæ, 627.  
 Vereker, J. G. P., Numerical Aperture,  
 819.  
 —, On the Choice of a Microscope,  
 823.  
 —, Presidential Address to the Postal  
 Microscopical Society, 305.  
 Vermes. See Contents, xiv.  
 Vermetus, Development of, 201.  
 Vermilia cæspitosa, Embryology of, 578.  
 Vernation of Leaves, 252.  
 Verson, E., Parthenogenesis in *Bombyx  
 mori*, 571.  
 Verworm, M., Biological Studies on Pro-  
 tista, 755.  
 —, Fresh-water Bryozoa, 27.  
 —, Method of investigating *Cristatella*,  
 147.  
 Vescovi, P. de, Method of Representing  
 and Calculating the Magnification of  
 Microscopic Objects in the projected  
 images, 135.  
 Vesque, J., Epidermal Reservoirs for Water  
 448.  
 Vessel for the Culture of Low Organisms,  
 657.  
 Vessels, Systematic Value of the Perfora-  
 tion in the Walls of 447.  
 Viallanes, H., Nerve-centres and Sensory  
 Organs of Articulata, 403.  
 Vibric from Nasal Mucus, 99.  
 Vibrios, 1017.

- Vibrios, Two kinds of, found in decomposing Hay Infusion, 100.
- Vicia Faba, Tubercular Swellings on the Roots of, 251.
- Victoria, Polyzoa of, 403.
- regia, Prickle-pores of, 81.
- Vigelius, W. J., Ontogeny of Marine Bryozoa, 936.
- Viguier, C., New Type of Anthozoa, 745.
- Villi on the Scales of Butterflies and Moths, 498.
- Villot, A., Development and Specific Determination of Gordii, 228.
- Vinassa, E., Pharmacognostic Microtome and Technique, 513.
- Vine, Mal nero of, 762.
- Vine-disease, New, 471.
- Vines, S. H., Movement of Leaf of *Mimosa pudica*, 457.
- , Systematic Position of Isoetes, 773.
- Virchow, H., Physics of the Yolk, 923.
- Vision in Arachnids, 214.
- of Caterpillars and Adult Insects, 404.
- , Powers of, 32.
- Viviparous Plants and Apogamy, 768.
- Voelting, H., Influence of Radiant Heat on the Development of the Flower, 995.
- Voeltzkow, A., *Aspidogaster conchicola*, 954.
- , Development in Egg of *Musca vomitoria*, 572.
- Vogt, C., *Arachnaetis* and *Cerianthus*, 743.
- Voimoff, R. G., On the different Cements for closing microscopical sections, 853.
- Volkens, G., Desert Flora, 617.
- , Salt-excreting glands of *Tamariscinae*, 249.
- Volvoeinae, &c., Chemotactic Movements of, 770.
- Vorce, C. M., Making Lantern Slides, 305.
- , The Meeting of the American Society of Microscopists, 141.
- Vorticellidæ, Conjugation of, 752.
- Vries, H. de, Isotonic Coefficient of Glycerin, 617.
- , New Application of the Plasmolytic Method, 1059.
- , Preservation of Plants in Spirit and the Prevention of Browning, 852.
- Vuillemin, P., *Ascospora Beijerinckii*, 1007.
- , Biological Studies of Fungi, 628.
- , Disease affecting Cherry and Plum-trees, 274.
- , — attacking *Amygdalæ*, 781.
- , Epidermal Glands, 81.
- and Bartet, —, "Rouge" of the Scotch Fir, 781.
- W.
- Wagner, E., Regeneration of Lost Parts, 215.
- , Tannin in the *Crassulacæ*, 603.
- V., Blood of Spiders, 916.
- Wagner, W., So-called Auditory Hairs, 411.
- Wahrlich, W., New *Pythium*, 98.
- Wainio, E., *Cladonia*, 621.
- Wakker, J. H., Crystalloids in Marine Algae, 463.
- , Crystals of Calcium oxalate, 445.
- , Elaioplast, 443.
- , Formation of Alourone-grains, 443.
- , Rejuvenescence of *Caulerpa*, 464.
- Waldeyer, W., Karyokinesis and Heredity, 554.
- , — in its Relation to Fertilization, 928.
- Waldner, M., Development of the Sporogonium of *Andreaea* and *Sphagnum*, 91, 1000.
- Walker, H. D., Gape Worm of Fowls, 740.
- Wall of Suberous Cells, 985.
- Walls of Vessels, Systematic Value of the Perforation in, 447.
- Walmsley, W. H., Photomicrography and the making of Lantern Slides, 652.
- Walsingham, Lord, Gape Worm of Fowls, 740.
- Ward, H. M., Structure and Life-history of *Puccinia Graminis*, 1007.
- , Tubercular Swellings on the Roots of *Vicia Faba*, 251.
- , and J. Dunlop, Fruits and Seeds of *Rhamnus*, 78.
- Ward, R. H., Fasadit's Test Plates, 300.
- , Indexing Microscopical Slides, 320.
- , Instantaneous Mounting in Farrant's Gum and Glycerin Medium, 520.
- Warm Chamber, Nuttall's, 1027.
- Wasps, Sand, 30.
- Wasserzug, E., *Fusoma*, 1009.
- , Principal processes of staining Bacteria, 159.
- , Spores of the Ferments, 633.
- Watase, S., Germinal Layers in Cephalopods, 931.
- , Homology of Germinal Layers of Cephalopods, 396.
- "Watchmaker Glass," Bausch and Lomb Optical Co.'s, 795.
- Water, Absorption of, and its Relation to the Constitution of the Cell-wall in Mosses, 263.
- , —, by *Gastropoda*, 563.
- and Soil, New and Typical Micro-organisms from, 789.
- , Epidermal Reservoirs for, 448.
- , Gelatin Culture Test for Micro-organisms of, 855.
- , Ingestion of, in Lamellibranchs, *Gastropods*, and *Pteropods*, 199.
- , Potato, and Apples for cultivation purposes, Sterilization of, 310.
- used for Brewing, Analysis of, as regards Micro-organisms, 685.
- Water-bath and Oven, Reeves's, 163.
- — —, Garbini's Closed, 1058.
- plants, Anatomy of, 77.
- Waterhouse, G. R., Obituary Notice, 141.

- Waterman, S., How to produce Hæmoglobin or Hæmatocrystallin, 856.
- Watson and Son's Anglo-Continental or Student's Microscope, 797.
- Watt, G., Indian Fibres, 495.
- Wax Cells, 519.
- Webb, —, Death of, 654.
- Weber, van Bosse, —, Algæ parasitic on the Sloth, 624.
- Wehmer, C., Action of Formose on Cells destitute of Starch, 85.
- Weibel, E., Two kinds of Vibrios found in decomposing Hay Infusion, 100.
- , Vibrio from Nasal Mucus, 99.
- , Vibrios, 1017.
- Weigert, C., New Method for Staining Fibrin and Micro-organisms, 675.
- Weigert's Hæmatoxylin-copper Stain for Nerve-fibre with the use of the freezing Microtome, Combining, 1051.
- Hæmatoxylin Method as applied to other than Nervous Tissues, 674.
- Weight, Decrease of, in Winter Pupæ of *Pontia brassicæ*, 572.
- of Chrysalis, Diminution in, 31.
- Well, L. A., Method for making Preparations of Bone and Teeth and retaining their soft parts, 1042.
- Weismann, A., Degeneration, 194.
- , Heredity, 926.
- , and C. Ischikawa, Formation of Polar Globules in Animal Ova, 705.
- , —, Partial Impregnation, 709.
- Weiss, D., Henocque's Hæmatoscope, 1029.
- , On the Fleischl Hæmometer, 808.
- , F. E., Some Oigopsid Cuttle-fishes, 931.
- Weldon, W. F. R., *Haplodiscus piger*, 955.
- Wellington District, New Zealand, Fresh-water Infusoria of, 972.
- Weltner, M., Survival of Spongillæ after Development of Swarm-larvæ, 596.
- , W., New Cirriped, 417.
- Wende, E., The Microscope in the Diagnosis of Skin Diseases, 856.
- Wendt, E. C., Roux's Colour-test for the detection of Gonococcus, 517.
- Wenham, F. H., Retirement of, 305.
- Went, F. A. T. C., Embryo-sac of Rosacæ, 610.
- , Increase of normal Vacuoles by Division, 981.
- , Nuclear and Cell Division, 243.
- Wesener, F., Staining Lepra and Tubercle Bacilli, 157.
- Wettstein, R. v., Abnormal Fructification of *Agaricus procerus*, 269.
- , Function of Cystids, 96.
- Wheat, Development of, 769.
- Whelpley, H. M., Microscopical Examination of Drugs, 1060.
- , Microscopy for Amateur Workers, 856.
- Whelpley, H. M., Preparing Slides to show Brownian Movement, 833.
- White, S. S., Dentist's Examining Glass, 795.
- (T. C.), Elementary Microscopical Manipulation, 165.
- , W., Colour-relation between Pupæ and Surroundings, 727.
- Whitman, C. O., Germ-layers of Clepsine, 37.
- , Kinetic Phenomena of the Egg during Maturation and Fecundation, 546.
- Wiedersheim, R., Ancestry of Man, 193.
- Wieler, A., Conduction of Sap through the Secondary Wood, 768.
- , Plasmolysis in Flowering Plants, 759.
- Wiener, O., Measuring Thin Films, 501.
- Wierzejski, A., Fresh-water Sponges, 748.
- , *Psorospermium Hæckelii*, 598.
- Wiesner, J., Albumen in the Cell-wall, 602, 982.
- , Influence of Atmospheric Movement on Transpiration of, 259.
- , The microscopical investigation of paper, with special reference to the oldest Oriental and European papers, 324, 521.
- Wigand, A., Colours of Leaves and Fruits, 254.
- , Crystal-plastids, 243.
- Wildeman, E. de, *Bulbotrichia*, 1003.
- , Microspora, 94.
- , *Trentepohlia*, 777.
- , *Ulothrix* and *Stichococcus*, 777.
- , — *crenulata*, 268.
- Wilfarth, H., Cultivation-bottle, 143.
- Wilkinson, W. H., Colour-reaction: its use to the Microscopist and to the Biologist, 320.
- Will, L., Development of Aphides, 573.
- Wille's (N.) Contributions to Algology, 626.
- Willem, V., Creeping Movements [in Gastropods], 718.
- Willfarth, —, and Helriegel, —, Absorption of Nitrogen by Plants, 770.
- Williams, G. H., Bausch and Lomb Optical Co.'s Petrographical Microscope, 279.
- Williamson, W. C., Anomalous Cells in the Interior of the Tissue of Fossil Plants, 605.
- Willot, —, *Heterodera Schachtii*, 953.
- Wilson, E. B., Germ-bands of *Lumbricus*, 38.
- , Preparing Moulds, 150.
- , H. V., Development of *Mancinia areolata*, 434.
- Wine from Barley, *Saccharomyces ellipsoideus* and its Use in the Preparation of, 785.
- Winged Fruits and Seeds, motion of rotating, 612.
- Winkler, W., Anatomy of *Gamasidæ*, 729.
- Winogradsky, S., Iron-bacteria, 786.

- Wisseligh, C. v., Wall of Suberous Cells, 985.
- Witt, O., and A. Truan, Photomicrographs of Diatoms, 295.
- Wojnoff, K., Some remarks on fixing microscopical sections to the slide, 853.
- Wolfe's (F.) Fresh-water Alga of the United States, 94.
- Wood, Conduction of Sap through the Secondary, 768.
- , Formation of Annual Rings in, 75.
- , Structure, represented in photomicrographs, Atlas of, 651.
- Wood, J. G., The Boy's Modern Playmate, 305.
- Woodhead, G. S., Method of preparation of large sections of the Lung, 834.
- , Preparing large Sections of Lung, 1043.
- Woodworth, W. M., Apical Cell of Fucus, 621.
- Woody Plants, Glucose as a Reserve-material in, 984.
- Tissue, &c., Staining, 675.
- Worms, New Remarkable, 428.
- Wortmann, J., Movements of Irritation, 259, 615.
- Wothschall, E., Micro-chemical reactions of Solanin, 1060.
- Wray, R. S., Methods of studying typical Bird's Feather, 314.
- Wright, R. R., and A. B. Macallum, Methods of studying Sphyrnura, 149.
- , Sphyrnura osleri, 47.
- Wurster, C., Congo-red as a Reagent for Free Acid, 1055.
- Wurtz, —, and Straus, —, Improved method for the Bacteriological Examination of Air, 854.
- X.
- Xerosis conjunctivæ, &c., Spore-formation in the Bacilli of, 1016.
- Xylem, Split, in Clematis, 248.
- Xyridæ, Roots and Rootlets in, 251.
- Y.
- Yeast-preparations, Stained, 156.
- Yolk, Physics of, 923.
- Z.
- Zabriskie, J. L., Continuous Centering of a Cover-glass, 850.
- Zacharias, E., Demonstrating Nuclein and Plastin, 503.
- , Division of the Nucleus and of the Cell, 440, 979.
- , Fertilization of *Ascaris megaloccephala*, 43, 148.
- Zacharias, E., Method of Preparing the Eggs of *Ascaris megaloccephala*, 663.
- , Part taken by the Nucleus in Cell-division, 63.
- , *Psorospermium Haackelii*, 240.
- , O., Distribution by Birds, 930.
- , of Arachnida, 215.
- Zagari, G., The culture of Anaerobic micro-organisms, 831.
- Zannichellia palustris, Pollination in, 256.
- Zeck, P., Elementary treatment of lens-systems, 501.
- Zeiss, C., 1034.
- , "Compensation Eye-piece 6 with 1/1 Micron-division," 797.
- Iris Diaphragm, 111.
- IIa. Microscope, 637, 794.
- , The New Apochromatic Micro-objectives and Compensating Oculars of, 1025.
- (R.) Photomicrographs, 525
- Zelinka, C., Parasitic Rotifer, *Discofus synapta*, 52.
- Zeller, E., Generative Apparatus of *Diplozoon paradoxum*, 427.
- Zentmayer, J., Obituary of, 655.
- Ziegler, H. E., Origin of Blood in Teleostei, 192.
- , The technique of the histological investigation of pathologico-anatomical preparations, 166.
- Ziemaeki, J., 320.
- Zimmerman, A., Demonstrating the Membrane of the Bordered Pits in Coniferæ, 155, 315.
- , Morphology and Physiology of the Cell, 442.
- , Staining Leneoplasts, Protein-granules, Bordered Pit Membranes, and Woody Tissue, 675.
- , Zeiss' Iris Diaphragm, 111.
- , E., and G. Baltzar, Microtome with fixed knife and automatic movement of the object, 812, 1049
- Zirconium Light for Photomicrography, 1033.
- Zonary Decidua in Mouse, Vestiges of, 186.
- Zopf, W., Chytridiacea parasitic on Diatoms, 99.
- , Cultivation of Phycomycetes, 469.
- , Fibrosin, a new cell-content, 246.
- , *Haplococcus reticulatus*, 782.
- , Isolating Lower Alga, 511.
- Zukal, H., Asci of *Penicillium crustaceum*, 271.
- Zune, A., Course of medical and pharmaceutical microscopy, 166, 686.
- Zwaardemaker, H., Accessory to the Cambridge Rocking Microtome, 669.
- Zygospores of Conjugatæ, 1002.

1888. Part 6a.

DECEMBER.

Gratis with  
No. 67.

JOURNAL  
OF THE  
ROYAL  
MICROSCOPICAL SOCIETY;

CONTAINING ITS TRANSACTIONS AND PROCEEDINGS,

AND A SUMMARY OF CURRENT RESEARCHES RELATING TO

ZOOLOGY AND BOTANY

(principally Invertebrata and Cryptogamia),

MICROSCOPY, &c.

*Edited by*

**FRANK CRISP, LL.B., B.A.,**

*One of the Secretaries of the Society*

*and a Vice-President and Treasurer of the Linnean Society of London;*

WITH THE ASSISTANCE OF THE PUBLICATION COMMITTEE AND

**A. W. BENNETT, M.A., B.Sc., F.L.S.,**

*Lecturer on Botany at St. Thomas's Hospital,*

**F. JEFFREY BELL, M.A., F.Z.S.,**

*Professor of Comparative Anatomy in King's College.*

**JOHN MAYALL, JUN., F.Z.S.,**

**R. G. HEBB, M.A., M.D. (Cantab.),**

AND

**J. ARTHUR THOMSON, M.A.,**

*Lecturer on Zoology in the School of Medicine, Edinburgh,*

FELLOWS OF THE SOCIETY.



WILLIAMS & NORGATE,

LONDON AND EDINBURGH.

JOURNAL  
OF THE  
ROYAL MICROSCOPICAL SOCIETY.

1888. Part 6a.

CONTENTS.

TITLE-PAGES.	PAGE
CONTENTS .. .. .	vii
CHARTER .. .. .	xliii
BYE-LAWS .. .. .	xlvii
INDEX .. .. .	1069



THE  
ROYAL MICROSCOPICAL SOCIETY.

(Founded in 1839. Incorporated by Royal Charter in 1866.)

---

**The Society** was established for the communication and discussion of observations and discoveries (1) tending to improvements in the construction and mode of application of the Microscope, or (2) relating to Biological or other subjects of Microscopical Research.

It consists of Ordinary, Honorary, and Ex-Officio Fellows.

**Ordinary Fellows** are elected on a Certificate of Recommendation signed by three Fellows, stating the names, residence, description, &c., of the Candidate, of whom one of the proposers must have personal knowledge. The Certificate is read at a Monthly Meeting, and the Candidate balloted for at the succeeding Meeting.

The Annual Subscription is 2*l.* 2*s.*, payable in advance on election, and subsequently on 1st January annually, with an entrance Fee of 2*l.* 2*s.* Future payments of the former may be compounded for at any time for 3*l.* 10*s.* Fellows elected at a meeting subsequent to that in February are only called upon for a proportionate part of the first year's subscription, and Fellows absent from the United Kingdom for a year, or permanently residing abroad, are exempt from one-fourth of the subscription during absence.

**Honorary Fellows** (limited to 50), consisting of persons eminent in Microscopical or Biological Science, are elected on the Recommendation of three Fellows and the approval of the Council.

**Ex-officio Fellows** (limited to 100) consist of the Presidents for the time being of such Societies at home and abroad as the Council may recommend and a Monthly Meeting approve. They are entitled to receive the Society's Publications, and to exercise all other privileges of Fellows, except voting, but are not required to pay any entrance Fee or Annual Subscription.

**The Council**, in whom the management of the affairs of the Society is vested, is elected annually, and is composed of the President, four Vice-Presidents, Treasurer, two Secretaries, and twelve other Fellows.

**The Meetings** are held on the Second Wednesday in each month, from October to June, in the Society's Library at King's College, Strand, W.C. (commencing at 8 P.M.). Visitors are admitted by the introduction of Fellows.

In each Session two additional evenings are devoted to the exhibition of Instruments, Apparatus, and Objects of novelty or interest relating to the Microscope or the subjects of Microscopical Research.

**The Journal**, containing the Transactions and Proceedings of the Society, with a Summary of Current Researches relating to Zoology and Botany (principally Invertebrata and Cryptogamia), Microscopy, &c., is published bi-monthly, and is forwarded post-free to all Ordinary and Ex-officio Fellows residing in countries within the Postal Union.

**The Library**, with the Instruments, Apparatus, and Cabinet of Objects, is open for the use of Fellows daily (except Saturdays), from 10 A.M. to 5 P.M., and on Wednesdays from 6 to 9 P.M. also. It is closed for four weeks during August and September.

*Forms of proposal for Fellowship, and any further information, may be obtained by application to the Secretaries, or Assistant-Secretary, at the Library of the Society, King's College, Strand, W.C.*







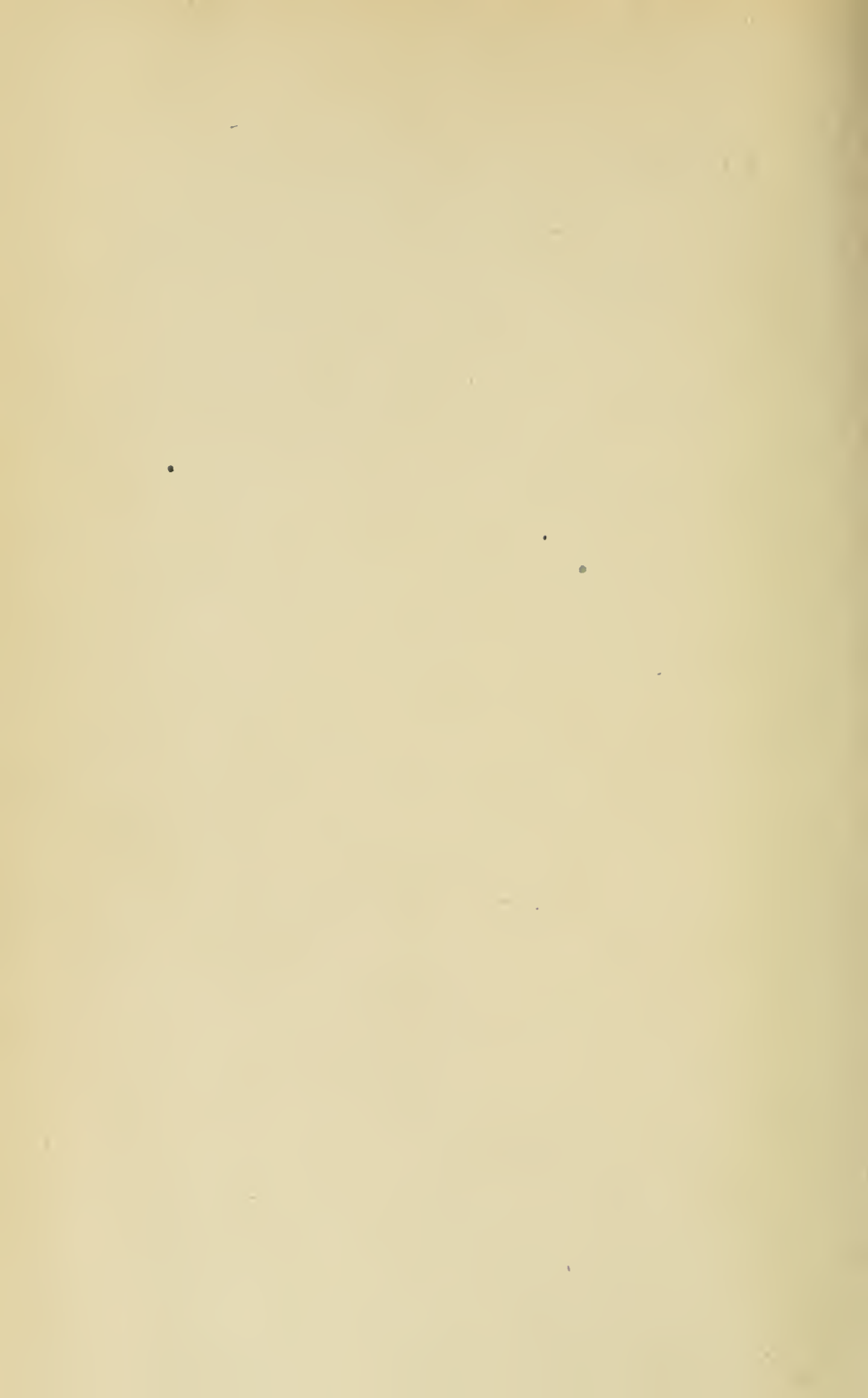



3 5185 00266 7796

