

Survival of Food Crops and Livestock in the Event of Nuclear War

Historic, archived document

Do not assume content reflects current scientific knowledge, policies, or practices

**United States
Department of
Agriculture**



National Agricultural Library

3602
20397

Survival of Food Crops and Livestock in the Event of Nuclear War

Proceedings of a symposium held at
Brookhaven National Laboratory
Upton, Long Island, New York
September 15-18, 1970

Sponsored by
Office of Civil Defense
U. S. Atomic Energy Commission
U. S. Department of Agriculture

Editors

David W. Bensen
Office of Civil Defense
Arnold H. Sparrow
Brookhaven National Laboratory

U.S. DEPARTMENT OF AGRICULTURE
NATIONAL AGRICULTURAL LIBRARY

OCT 28 1996

CATALOGING PREP.

December 1971

AVAIL AS CONF-700909 FOR \$26.75
FROM
: NATIONAL TECHNICAL INFORMATION SV
U.S. DEPARTMENT OF COMMERCE
SPRINGFIELD VA 22161

Library of Congress Catalog Card Number: 77-170334

Printed in the United States of America
USAEC Technical Information Center, Oak Ridge, Tennessee

December 1971

FOREWORD

Since its inception, the Brookhaven National Laboratory has had a deep and active interest in the effects of radiation, including radiation from fallout. As examples of this interest, we can list the East River Project, carried out in large part by the laboratory many years ago; the initial and continuing care of the Marshallese who were accidentally exposed to large doses of fallout radiation in 1954; and the extensive studies at Brookhaven on the effects of radiation on animals and plants.

The particular interest at this symposium is radiation effects resulting from high-dose exposure, rather than the effects of low-level exposure (i.e., doses and dose rates commensurate with the radiation-exposure guides for radiation workers and for the public). These studies, of course, have a strong pragmatic component, in that the objective is to develop the ability to predict the potential effects of large doses of radiation on man directly and indirectly via possible detrimental effects on animals and food crops and via isotopes in the food chain. We must be able to evaluate the relative importance of these and other factors in the overall damage situation following nuclear warfare.

However, I do not need to remind you that studies on the effects of radiation have led and will continue to lead to very basic findings, the importance of which transcends pragmatic considerations. For instance, Arnold Sparrow's excellent work on the relation of the chromosome volume to radiation sensitivity has told us a great deal about the sensitive unit within the cell. The entire concept of repair at a molecular or biochemical level grew out of radiation studies. Whole new areas of scientific endeavor owe their effective origin to radiation studies. Cell and tissue kinetics, now a very large field involving many hundreds of investigators, grew from the need to understand these processes both in the context of the effects of radiation of the entire animal and plant and of radiotherapy. The

FOREWORD

field of tissue transplant, now progressing at an accelerated pace, owes its origin to early attempts to modify radiation injury in the mammal by means of bone-marrow transplants. Immunology also received enormous impetus from findings derived from studies of impaired immunological response following large doses of radiation.

These examples remind us that, while many of the goals of this symposium are pragmatic, these investigators are indeed dealing with very basic problems in sciences.

V. P. Bond
Associate Director
Brookhaven National Laboratory

PREFACE

Results of ongoing research and study reported in these symposium proceedings should significantly improve the ability to forecast and assess the postattack availability and safety of food should a nuclear attack on this country occur. This improvement could not have occurred, of course, without an accompanying expansion in knowledge of the basic scientific phenomena involved.

A number of the problems that would confront the nation following nuclear attack were identified and discussed in the proceedings of a symposium on Postattack Recovery from Nuclear War held at Fort Monroe, Virginia, in November 1967.

The consensus of the symposium was that, after such an attack, crippling problems of food, health, ecology, and long-term effects on man were unlikely. Major areas of greatest doubt and less optimism were those of postattack management (including both government and private sectors of the economy) and of motivations, incentives, and behavior of the population at all levels.

Since the Fort Monroe meeting, significant new information on the food problem has been developed. In particular, sufficient new research data on the effects of fallout radiation—both beta and gamma—on food crops and livestock have accumulated to warrant a symposium to review and consolidate these data and to make them available for planning purposes.

The conclusion of the earlier symposium that crippling problems of food appear unlikely remains valid when applied to the total resources that should be available to the nation. However, it is certain that there would be serious local shortages and that damage to individual crops and herds would be extensive.

This symposium serves two other important purposes: (1) It provides an improved communication link between the users of research information and the scientists who produce it. (2) Perhaps of equal significance, it demonstrates a mutuality of interests among

PREFACE

the three sponsoring federal agencies, the Office of Civil Defense, the Atomic Energy Commission, and the Department of Agriculture.

Although this symposium indicates that the broad dimensions of the postattack food-supply problems are generally understood, some uncertainties still exist. Through discussions and working group sessions, the types of additional research and study needed to clarify this important aspect of national survival were identified.

To this end an Interagency Technical Steering Committee represented by the Office of Civil Defense, the Atomic Energy Commission, and the Department of Agriculture has been created for the purpose of coordinating and guiding research in which a mutuality of interest exists.

John E. Davis

Director of Civil Defense

CONTENTS

Session I: The Hazard—Properties of Fallout

Introductory Remarks	1
<i>Jack C. Greene</i>	
Physical, Chemical, and Radiological Properties of Fallout	9
<i>J. H. Norman and P. Winchell</i>	
Beta-Radiation Doses from Fallout Particles Deposited on the Skin	31
<i>S. Z. Mikhail</i>	
Measurement and Computational Techniques in Beta Dosimetry	51
<i>James Mackin, Stephen Brown, and William Lane</i>	
Measurement of Beta Dose to Vegetation from Close-In Fallout	56
<i>A. D. Kantz</i>	
The Importance of Tritium in the Civil-Defense Context	71
<i>J. R. Martin and J. J. Koranda</i>	
Properties of Fallout Important to Agriculture	81
<i>Carl F. Miller</i>	
Preparation and Use of Fallout Simulants in Biological Experiments	107
<i>William B. Lane</i>	

CONTENTS

Session II: Fallout-Radiation Effects on Livestock

Fate of Fallout Ingested by Dairy Cows	115
<i>G. D. Potter, G. M. Vattuone, and D. R. McIntyre</i>	
Fate of Fallout Ingested by Swine and Beagles	125
<i>Robert J. Chertok and Suzanne Lake</i>	
Radionuclide Body Burdens and Hazards from Ingestion of Foodstuffs Contaminated by Fallout	131
<i>Yook C. Ng and Howard A. Tewes</i>	
Retention of Simulated Fallout by Sheep and Cattle	173
<i>James E. Johnson and Arvin I. Lovaas</i>	
Simulated-Fallout-Radiation Effects on Sheep	178
<i>L. B. Sasser, M. C. Bell, and J. L. West</i>	
Simulated-Fallout-Radiation Effects on Livestock	193
<i>M. C. Bell, L. B. Sasser, and J. L. West</i>	
Pathology of Gastrointestinal-Tract Beta-Radiation Injury	208
<i>J. L. West, M. C. Bell, and L. B. Sasser</i>	
Responses of Large Animals to Radiation Injury	224
<i>David C. L. Jones</i>	
Criteria for Radiation Injury	234
<i>John S. Krebs</i>	
Species Recovery from Radiation Injury	245
<i>J. F. Spalding and L. M. Holland</i>	
Radioiodine Air Uptake in Dairy Cows After a Nuclear-Cratering Experiment	259
<i>Ronald E. Engel, Stuart C. Black, Victor W. Randecker, and Delbert S. Barth</i>	
Problems in Postattack Livestock Salvage	269
<i>S. A. Griffin and G. R. Eisele</i>	

CONTENTS

Session III: Fallout-Radiation Effects on Plants

- Exposure-Rate Effects on Soybean Plant
Responses to Gamma Irradiation 277
M. J. Constantin, D. D. Killion, and E. G. Siemer
- Effects of Acute Gamma Irradiation on
Development and Yield of Parent Plants and
Performance of Their Offspring 287
E. G. Siemer, M. J. Constantin, and D. D. Killion
- Effects of Exposure Time and Rate on the
Survival and Yield of Lettuce,
Barley, and Wheat 306
P. J. Bottino and A. H. Sparrow
- Dose-Fractionation Studies and Radiation-Induced
Protection Phenomena in African Violet 325
C. Broertjes
- Summary of Research on Fallout Effects on
Crop Plants in the Federal Republic of Germany 343
Hellmut Glubrecht
- Radiation Doses to Vegetation from Close-In
Fallout at Project Schooner 352
W. A. Rboads, H. L. Ragsdale, R. B. Platt, and E. M. Romney
- Survival and Yield of Crop Plants
Following Beta Irradiation 370
Robert K. Schulz
- Field Studies of Fallout Retention by Plants 396
John P. Witherspoon
- Retention of Near-In Fallout by Crops 405
A. I. Lovaas and J. E. Johnson

Session IV: Effects of Fallout Radiation on Agricultural and Natural Communities

- Prediction of Species Radiosensitivity 419
*Harvey L. Cromroy, Richard Levy,
Alberto B. Broce, and Leonard J. Goldman*

CONTENTS

Insect-Induced Agroecological Imbalances as an Analog to Fallout Effects	434
<i>Vernon M. Stern</i>	
Ecological Effects of Acute Beta Irradiation from Simulated-Fallout Particles on a Natural Plant Community	454
<i>Peter G. Murphy and J. Frank McCormick</i>	
Effect of Nuclear War on the Structure and Function of Natural Communities: An Appraisal Based on Experiments with Gamma Radiation	482
<i>G. M. Woodwell and B. R. Holt</i>	
Prediction of Radionuclide Contamination of Grass from Fallout-Particle Retention and Behavior	492
<i>Roger C. Dabلمان</i>	
Responses of Some Grassland Arthropods to Ionizing Radiation	509
<i>Clarence E. Styron and Gladys J. Dodson</i>	
Survival of Crickets, <i>Acheta domesticus</i> (L.), as Affected by Variations in Gamma Dose Rate	521
<i>R. I. Van Hook, Jr.</i>	
Effects of Beta-Gamma Radiation of Earthworms Under Simulated-Fallout Conditions	527
<i>David E. Reichle, John P. Witherspoon, Myron J. Mitchell, and Clarence E. Styron</i>	
Cesium-137 Accumulation, Dosimetry, and Radiation Effects in Cotton Rats	535
<i>D. DiGregorio, P. B. Dunaway, J. D. Story, and J. T. Kitchings III</i>	
Session V: Considerations in Agricultural Defense Planning	
The Significance of Long-Lived Nuclides After a Nuclear War	548
<i>R. Scott Russell, B. O. Bartlett, and R. S. Bruce</i>	
Control of Fallout Contamination in the Postattack Diet	566
<i>J. C. Thompson, Jr., R. A. Wentworth, and C. L. Comar</i>	

CONTENTS

Sensitivity Analysis of Agricultural Damage Assessment	595
<i>Stephen L. Brown</i>	
Application of Damage-Assessment Data in U. S. Agricultural Defense Planning	608
<i>Bruce M. Easton</i>	
United Kingdom Considerations in Agricultural Defense Planning	616
<i>W. T. L. Neal</i>	
Appendix A: Reports of Committee Working Groups	
Committee 1: Vulnerability of Livestock to Fallout Beta and Gamma Irradiation	627
Committee 2: Vulnerability of Crops to Fallout Beta Irradiation	630
Committee 3: Vulnerability of Crops to Fallout Gamma Irradiation	633
Committee 4: Beta Dosimetry: Calculational Techniques and Measurements	637
Committee 5: Fallout Radiation Fields	639
Committee 6: Radioecological Effects of Fallout Radiation	643
Committee 7: Use and Requirements for Research Data in Agricultural Defense Planning	645
Appendix B: Radiation Effects on Farm Animals and Crops	
Vulnerability of Livestock to Fallout Gamma Radiation	648
<i>Edwin T. Still and Norbert P. Page</i>	
Radiation Effects on Farm Animals: A Review	656
<i>M. C. Bell</i>	
The Effects of External Gamma Radiation from Radioactive Fallout on Plants, with Special Reference to Crop Production	670
<i>A. H. Sparrow, Susan S. Schwemmer, and P. J. Bottino</i>	
List of Attendees	712
Author Index	719
Subject Index	721



INTRODUCTORY REMARKS

JACK C. GREENE

Office of Civil Defense, Washington, D. C.

May I extend a warm welcome to you all. I am highly gratified at the extent of interest in the subject matter of this symposium, as evidenced by our fine roster of speakers and by the size and diversity of the audience. John E. Davis, National Director of Civil Defense, asked me especially to note his interest in the proceedings of the symposium and his concern about the problems to be discussed. He wished us a very successful meeting.

As perhaps most of you know, this is the fourth in the series of conferences on the general subject of survivability of food crops and livestock in the event of a nuclear attack. The first, which was primarily an organizing and planning session, was held at Estes Park, Colo., in June 1967. The second was in Oak Ridge, Tenn., in May 1968. By the time of the third, which was held in June of last year in Fort Collins, Colo., a sufficient body of research data highly relevant to the civil-defense question had become available and needed to be reported and recorded in the literature. That was when the idea for the Brookhaven Symposium germinated, and the decision was made that for the first time we would ask for manuscripts of the papers to be presented. We are highly pleased that the Atomic Energy Commission has agreed to publish these papers as a volume in their Symposium Series.

The research fraternity represented here is relatively quite small. If we were to give proper credit to all those who have contributed to the recent very rapid expansion of knowledge in this field, we would have to list, as a minimum, all the speakers for the symposium. Let me, however, acknowledge only a few. Arnold Sparrow, our host and cochairman of the conference, has pioneered in studies of plant radiosensitivity. We should note also the contributions of Nathan Hall, Vernon Cole, and Carl Bell, whose foresight and painstaking preparatory work lead to the definition of the Office of Civil Defense's research program in this area. And, finally, on behalf of the Office of Civil Defense, I

wish to acknowledge formally the fine spirit of cooperation displayed by our cosponsors of the symposium, the Department of Agriculture and the Atomic Energy Commission.

Now I shall take a few minutes to, in effect, step back from the focus on food survivability and attempt to provide a perspective on how food fits into the overall problem of survival and recovery from nuclear attack. Obviously food is a necessary consideration for survival, but food alone is not sufficient for survival. My purpose here is to point out to you some of the other constituents of sufficiency. To do this I shall employ a flow diagram model of U. S. society during and after a nuclear attack (Fig. 1). The descriptive material in the following paragraphs about the flow-diagram transfer coefficients is based on a very large number of research studies conducted over the past several years by personnel and contractors of the Office of Civil Defense and other organizations.*

If P is the size of the U. S. population immediately prior to a nuclear war, then what happens to P as a result of the war can be examined in terms of the flow diagram shown in Fig. 1.

If the initial flow input is of magnitude P and each of the attack effects is represented by an impediment, or barrier, to flow, then the value of the transfer coefficient represents the fraction of population that successfully passes the particular barrier to which a given coefficient applies. (It may be useful to think of each barrier as a sort of semipermeable membrane.)

The fraction of the preattack population which survives all the attack effects is the product of the transfer coefficients $a \cdot b \cdot c \cdot d \cdot e \cdot f \cdot g \cdot h \cdot i$. Clearly the objective of a civil-defense system (or any other military offense or defense system) is to make this product as large as possible. It is equally clear that if any single transfer coefficient is critically small, there is no point in attempting to raise the others until the critical one is also raised.

Each of these transfer coefficients will now be discussed in turn, both in terms of probable range of values and in terms of action needed either to lessen the uncertainties about the coefficients or to increase their values.

Direct Weapons Effects. The transfer coefficient for direct weapon effects, a , represents the fraction of the preattack U. S. population surviving the blast and initial thermal and nuclear radiation. For today's civil defense, a probably would be in the range of 0.5 to 0.8, depending on the type and weight of attack. Employment of antiballistic missiles, blast shelters, or preattack evacuation increases a .

Fallout. The transfer coefficient for lethal fallout effects, b , represents the fraction of the population surviving the direct effects (a) and also surviving the

*Those wishing to pursue a particular point or to obtain specific references may do so by communicating with me at the following address: Postattack Research Division, Office of Civil Defense, The Pentagon, 1E542, Washington, D. C. 20310; Phone: Area 202, 695-9613.

hazard of lethal fallout-radiation doses. Typical results of hypothetical attacks indicate that b would be in the range of 0.4 to 0.8. The value of b can be increased cheaply, at least on the margin; i.e., expenditures to save lives with a fallout shelter program are highly cost effective, as are expenditures to educate the public on the nature of the fallout threat and means of protecting against it.

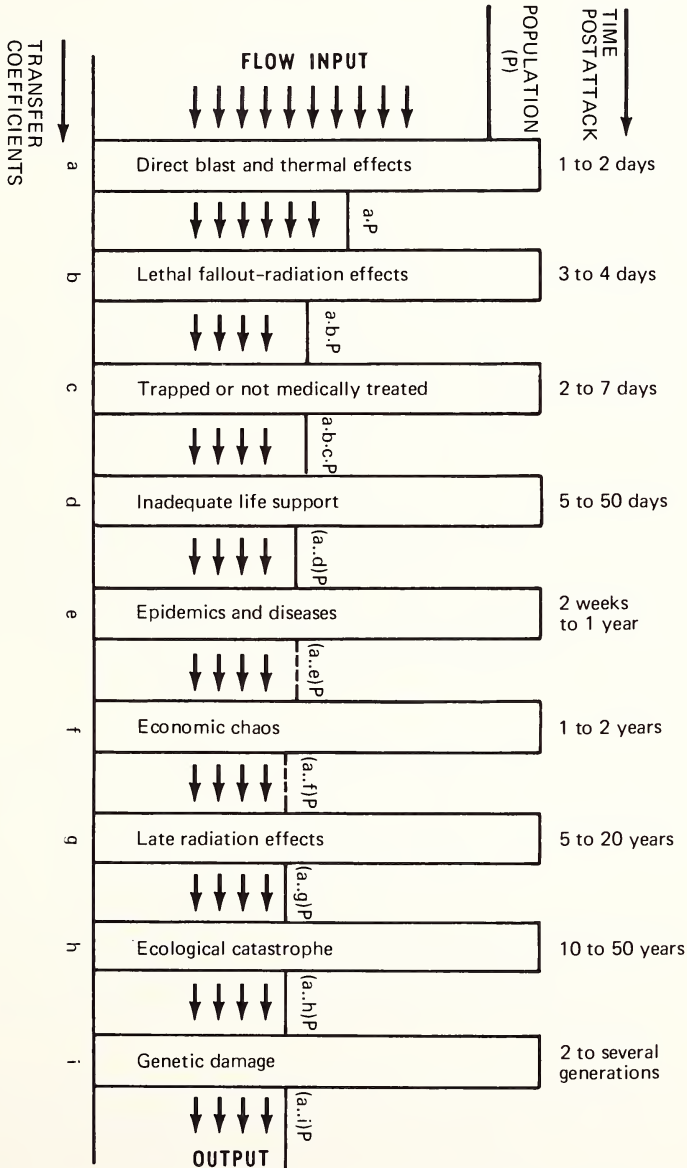

Fig. 1 Flow-diagram model of U. S. society during and after nuclear attack.

For just these reasons the emphasis of the current civil-defense program is on fallout protection.

At this point the flow diagram may be used to illustrate the importance of viewing civil defense as a system. A certain tactic intended to raise b may appear highly attractive if a narrow perspective is applied (suboptimization). But if this tactic at the same time reduces some other transfer coefficient, say a , so that the product ab becomes less than it was before, the tactic obviously is not desirable. For example, a policy of sending people to the upper stories of high-rise buildings to increase fallout protection in target areas may decrease b , but the accompanying increase in a (deaths due to initial weapons effects) may result in a net decrease in the number of people surviving both effects. Table 1 indicates how a and b might vary as a function of the weight of attack.

Table 1
TRANSFER COEFFICIENTS a AND b AND THEIR PRODUCT
FOR VARIOUS WEIGHTS OF ATTACK*

Transfer coefficient	1000 Mt†	3000 Mt	5000 Mt	7000 Mt	9000 Mt
a	0.78	0.64	0.57	0.54	0.49
b	0.81	0.70	0.58	0.48	0.39
$a \cdot b$	0.63	0.45	0.33	0.26	0.19

*Data are based on a composite of damage-assessment studies by the Department of Defense. The attacks were assumed to be against military-urban-industrial targets, and people were assumed to use the best protection available in the normal place of residence.

†Units of attack weight are in megatons equivalent of TNT.

Rescue and Medical Care. The transfer coefficient c is attributable to the effectiveness of emergency operations services, such as rescue and medical teams and represents the fraction of the population surviving blast, thermal, and fallout effects, not already foredoomed to die, which could and would be saved by rescue and emergency medical care. Contrary to much prevalent intuition, c probably is a fraction near 1. The reason for this is not that rescue and medical care are expected to be highly effective, but that the percentage of people that *could* be rescued in time or *could* be saved by medical care is very small. Therefore expenditures to increase c do not appear to very cost effective. (The value for c is probably greater than 0.95.)

Life-Support Requirements. The transfer coefficient d represents survival during the very early postattack period when people in shelters or other isolated locations could be running out of food or water or the shelters (because of inadequate ventilation) might become intolerable. The value of d depends on

how rapidly food-, water-, and power-distribution systems can be reestablished and how rapidly an effective emergency management system evolves. In some localities and under some conditions, the problems could be severe. Very hot or very cold weather, radiological constraints, and disrupted transportation and communications systems could have a serious impact. This area requires more study and the development of individual plans tailored to the needs of individual localities and situations. On a national average, however, d is not likely to fall much below 1.0.

Epidemics and Diseases. The transfer coefficient for epidemics and diseases is e . Postattack health problems could be exacerbated because of disrupted water and sewerage systems, malnutrition, and radiation exposures. The range of e might be wide, but, with reasonable precautions and attention, it probably could be kept high. The national average value for e should be above 0.95. Additional study and development of contingency plans for specific health problems that might occur are needed and are being undertaken.

The Economy. The transfer coefficient accounting for the requirement that the economy become functional and produce the commodities essential to sustain the attack survivors before surviving inventories are used up is f . In this respect it is particularly fortuitous that the U. S. agricultural industry is highly efficient. About 6% of the U. S. population produces not only enough food to feed America but also vast quantities for export.

Numerous studies show that the physical wherewithal (transportation, fertilizer and petroleum products, essential industry, etc.) to continue to provide food to sustain the survivors of a nuclear attack would also survive. This damaged economy could provide for an adequate diet and for the other items essential to survival without undue strain, and a surplus of labor, capital, and raw materials would be left with which to rebuild the economy. It is not enough, however, to say that the physical capacity to sustain survivors would exist. One has only to recall that there was no physical incapacity of the nation's ability to produce in the late 1920's and early 1930's during the worst depression of U. S. history. The machine was in good shape; the problem was that management did not know how to operate it. To expect efficient or even adequate operation of an economy damaged by a massive nuclear attack, with the attendant social and psychological trauma, may be highly optimistic.

If there is an Achilles' heel in the postattack recovery system, it probably lies in f , the transfer coefficient relating to economic chaos. But this Achilles' heel, if it exists, is not inherent; it would result from inadequate planning and preparations for management rather than from limitations of the physical capacity to produce.

Late Radiation Effects. The transfer coefficient g accounts for the people who would die from bone cancer, leukemia, thyroid damage, and other radiation-induced effects. Although the impact on the survivors might well be detectable

(and might have a more important psychological than physiological impact), these late radiation effects pose little threat to the society's survival. The value of g probably is a number greater than 0.99. The research in this area is done largely under AEC and U. S. Public Health Service sponsorship. Charles L. Dunham (former Director of the AEC Division of Biology and Medicine and currently the Chairman of the Division of Medical Sciences, Academy of Sciences) recently summarized the long-term effects with the following statement: "20,000 additional cases per year of leukemia during the first 15 to 20 years postattack followed by an equal number of cases of miscellaneous cancers, added to the normal incidence in the next 30 to 50 years, would constitute the upper limiting case. They would be an unimportant social, economic, and psychological burden on the surviving population." (The Dunham statement was in reference to specific hypothetical attacks—one, CIVLOG, was a 455-weapon 2000-Mt attack; the other, UNCLEX, was an 800-weapon 3500-Mt attack. Current status of civil defense was assumed.)

The yearly rate appearing today for the 200-million U. S. population is about 20,000 new cases of leukemia. There are about 15,000 deaths per year due to this cause.

The Ecology. The transfer coefficient h accounts for the damage to the ecology which could occur from the nuclear attack. Probable ecological consequences of nuclear war are still uncertain. Extensive research programs are underway, and progress is being made. The most comprehensive program, at least in the Western World, is that of the Radioecology Section of the Oak Ridge National Laboratory—research partially supported by OCD over the last several years.

The "doom and gloom" predictions prevalent in the late 1950's and early 1960's are not supported by this research. The summary report of Project Harbor, a 1963 study of civil defense by a committee of the National Academy of Sciences under the leadership of Eugene Wigner, contains this statement: "Large-scale primary fires, totally destructive insect plagues, and ecological imbalances that would make normal life impossible are not to be expected." In the 1969 study (again under the leadership of Dr. Wigner) intended to update the Project Harbor work, is the following statement: "A reasonable conclusion, therefore, is that the long-term ecological effects would not be severe enough to prohibit or seriously delay recovery."

Some perspective as to the possible ecological effects of a nuclear attack can be gained by considering that man is now, in peacetime, doing just about everything he can do to upset the ecological balances. The ultimate results on the ecology of water and air pollution and of widespread application of herbicides and insecticides are beyond our knowledge to predict; *but, whether or not there is a nuclear war, these problems have to be faced and solved.* At this point in the flow diagram, it is no longer feasible to ascribe a numerical value to the transfer coefficient. By the time these ecological consequences would manifest themselves, limiting the growth of population might have again become

a socially desirable goal. But to think that the ecological damage of nuclear war would be so severe as to limit flow in the concept of the diagram is just not justified. (Though verging on the macabre, it should be pointed out that a nuclear war could alleviate some of the factors leading to today's ecological disturbances that are due to current high-population concentrations and heavy industrial production.)

Genetic Effects. The transfer coefficient for genetic damage, *i*, is included primarily for completeness. Genetic effects, like late radiation and ecological effects, are widely misunderstood, and consequently feared, and probably have aroused more emotional heat than the others. Although *g*, *h*, and *i* could be important, there is little question that they represent minor consequences compared with others.

The genetic effects of radiation exposure have received a great deal of study—with animals in the laboratory and with humans in follow-up studies of people given radiation for therapeutic and diagnostic purposes, people involved in accidents, and the survivors of Hiroshima and Nagasaki. The Atomic Bomb Casualty Commission, a joint U. S.—Japanese study, has had an extensive program underway in Japan since the early days following World War II.

Dr. Dunham, in the same summary referred to previously, said, "The genetic effects would be lost, as at Hiroshima and Nagasaki, in all the other 'background noise'."

The concepts that people harbor about late radiation, ecological, and genetic effects probably are far more severely distorted than those concepts about any of the other potential attack effects. To illustrate, in May 1970, *The New Yorker* magazine's lead article contained the following statement: "Since the development of nuclear weapons, everyone has known that an international crisis could lead to the *extinction of the human species*." Other examples just as dramatic can be found in Robert Kennedy's book on the Cuban crisis. The following quote is typical: "Each one of us was being asked to make a recommendation which would affect the future of all mankind, a recommendation which, if wrong and if accepted, could mean the *destruction of the human race*." (Italics in both references are used for emphasis.)

I cannot prove by this flow-diagram model or by any other analytical device or line of reasoning that this country could survive and recover from a nuclear attack, any more than I can prove that we will satisfactorily solve our pollution or population-growth problems or work out a more acceptable rapprochement with our young. On the other hand, when people make dogmatic statements to me claiming that we could not survive and recover from a nuclear attack, I defy them to identify in accordance with this or with any other model the barrier or barriers that would be insuperable.

In any case, I am firmly convinced that our chances of survival and recovery from a nuclear catastrophe, should it occur, will be much higher, the progress

much faster, and the trauma less severe if we have studied and understand the potential problems and have figured out the best ways of handling them.

An absolute requisite at any stage of the recovery process is an adequate supply of food that is nutritionally sufficient and radiologically acceptable. The work that is being reported here constitutes, I believe, a giant step toward understanding the physical and physiological components of this food problem. More work is needed, especially work to improve the plans and procedures for allocation and distribution of food. If civil defense, like the army, "must travel on its stomach," the work you are doing will help assure that the wherewithal to travel is in plentiful supply.

PHYSICAL, CHEMICAL, AND RADIOLOGICAL PROPERTIES OF FALLOUT

J. H. NORMAN and P. WINCHELL
Gulf General Atomic Company, San Diego, California

ABSTRACT

The importance to a biological-damage model of physical chemistry associated with the sorption of fission products by fallout is suggested. Calculated sorption behavior for Small Boy fallout of several nuclide chains is demonstrated according to a condensed-state diffusion-limited sorption model. An experiment on glassy Johnie Boy fallout revealed a diffusion-controlled profile of ^{137}Cs in partial support of the calculated model.

To describe the biological activity of the various fission-product nuclides, we must understand the leaching properties of radionuclides in the fallout particles. As an initial report on our work in this field, we considered sorbed iodine transport in contact with (1) moist air and (2) solutions. Sodium and iodine leaching from several glasses was also studied. Leaching of fission products from a $\text{CaO}-\text{Al}_2\text{O}_3-\text{SiO}_2$ glass a few days after recoil loading was studied. In these leaching studies the data were fitted to several models: surface-reaction-rate-limited, diffusion-limited, and desorption-limited processes. The observation of the pertinence of several models suggests considerable complexity in a leaching model for fallout.

The most important questions in characterizing fallout with respect to a biological-damage model are:

1. How much fallout has been deposited in the region of concern?
2. How much radioactivity as a function of time is associated with the fallout?
3. What is the distribution of the radioactivity with respect to the fallout particles?
4. What is the physical, chemical, and radiological behavior of the particles with respect to the environment?

Tolerance levels for various radionuclide exposures must be established, of course. Nevertheless, the essential doses and dose rates resulting from an

exposure to fallout are intimately connected with the description of the fallout. Therefore our premise is that knowledge of fallout properties is necessary for radiological-damage estimates, and thus a damage model must incorporate a fallout model as a base.

During the last two decades, there has been a considerable effort to formulate a physical-chemical fallout-formation model. Fractionation of volatile fission products was noted early by Freiling.¹ Models have been constructed, for instance, by Freiling,² Miller,³ and Korts and Norman⁴ to simulate fractionation. Considerable effort has been made to define the phenomena involved in fallout formation. Recently Freiling⁵ presented a good description of nonturbulent, nonagglomerating fallout formation in which fission-product sorption is described as controlled by one or more of three processes: gas-phase diffusion, condensed-phase diffusion, and surface condensation. He presented a basic method for determining the importance of each of these processes to fallout formation. This method involves evaluating the basic chemical and physical parameters associated with each of these phenomena. Freiling lists these parameters as follows:

1. Particle radii and distributions thereof.
2. Vapor-phase diffusivities.
3. Condensed-phase diffusivities.
4. Henry's law constants (distribution coefficients).
5. Condensation coefficients.
6. Mean molecular speed of the gas-phase species.

Information is available for most of these quantities for evaluating fallout formation. Particle-size distributions have been discussed many times.^{6,7} Heft's⁸ bimodal particles certainly should be considered. Vapor-phase diffusivities and mean molecular speeds can be readily derived from knowledge of the gaseous species and the pressures and temperatures encountered during fallout formation. Norman⁹ presented an estimate of Henry's law constants for silicates, and information on silicate diffusivities was presented by Winchell and Norman.¹⁰ Condensation-coefficient studies were performed by Adams, Quan, and Balkwell¹¹ and by Bloore et al.¹² Russell¹³ also contributed to an understanding of several of these phenomena.

Although the phenomenological studies have shown considerable promise, much less has been accomplished in terms of establishing a model incorporating the six parameters. Miller³ provided the first physical-chemical model, which employed a step response in condensed-state diffusivity at a soil melting temperature, surface equilibrium, and Raoult's law constants (i.e., fission products were assumed to condense in silicates according to ideal-solution law until particles froze, and thereafter they were assumed to surface deposit). Korts and Norman⁴ constructed a more general model in which a set of Henry's law constants⁹ was employed along with silicate-diffusion constants to make

approximate dynamic calculations of condensed-state profiles assuming that the gas phase was in equilibrium with the surfaces of the fallout particles.

These models are very complex. An interdecaying population of fission products must be imposed on the kinetics of sorption. The set of differential equations to describe fully the decaying population and sorption by the three listed processes is extensive, and good, approximate solutions are difficult to achieve.

The problem of obtaining a complete physical-chemical model, then, is discouraging to those looking for a quick answer. Some empirical models have been developed [e.g., the U. S. Naval Radiological Defense Laboratory (USNRDL) RAD model²] which have proved quite useful, but they do not describe well some properties important to biological activity.

At this point we will consider further the Korts-Norman model as a possible limiting physical-chemical description of fallout. Model features that should be important in fallout are the predicted fractionation, the nature of fission-product-penetration profiles, and the activity division according to particle size. These features can be calculated for a field of altered and unaltered fallout according to Heft's suggestions.⁸ Fractionation affects the quantity and type of fission products encountered in a given region of a fallout pattern since sedimentation rates are particle-size dependent. Profiles affect the beta-dose rates from particles, as discussed by Mikhail,¹⁴ and also the biological availability. The model output, together with a leaching description of the matrix, determines the mobility of fission products. The character of the fallout itself establishes the sorptive and leaching properties. Altered (from molten droplets to glassy spheres) and unaltered debris exhibit considerably different fission-product profiles. Late or peripheral entry of debris into the cloud is important, as are sorptive properties and leaching properties of the debris.

The basic question is: What is necessary to provide a better physical-chemical description of fallout for use in a biological model? Our answer is twofold: (1) Establish fission-product profiles in fallout particles, and (2) establish the degree of corrosion of and migration in fallout particles under appropriate conditions. The remainder of this paper bears on these two points.

DESCRIPTION OF FALLOUT ACCORDING TO THE CONDENSED-STATE DIFFUSION-CONTROLLED FISSION-PRODUCT SORPTION MODEL

The condensed-state diffusion model for fission-product absorption assumes (1) that the rate of fission-product sorption during the critical time-temperature regime is controlled by diffusion of surface-absorbed fission products into the bulk of fallout particles, (2) that the surface of a particle is in equilibrium with the neighboring gas, and (3) that the pressures of the gaseous fission products are locally constant (i.e., that gas-phase diffusion is fast enough that local fission-product pressure gradients are negligible). Descriptions of the calcula-

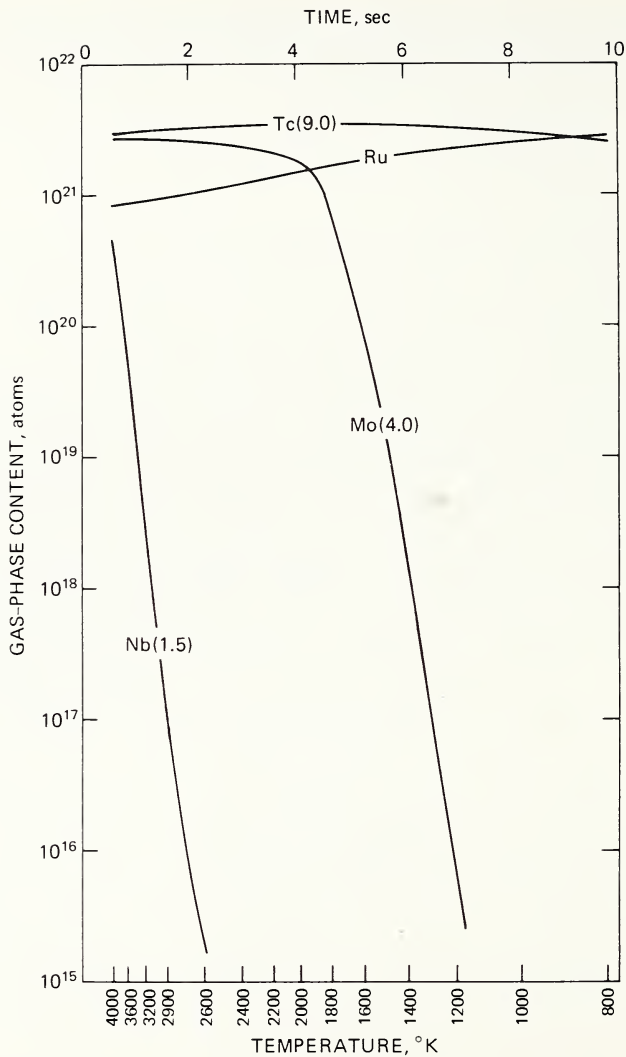

Fig. 1 Calculated gas-phase concentrations in 106 chain for Small Boy (ruthenium precursors and half-lives in seconds listed).

tional methods and some parameter scaling for this model were presented by Korts and Norman.⁴ A short description of the model was given by Norman et al.,¹⁵ and a parametric study including some simulated Small Boy calculations was presented by Norman et al.¹⁶ In this report, some additional data from our Small Boy calculations are presented to demonstrate the properties of the model which are important to a biological-activity model. The Small Boy time-temperature history is approximated on the abscissas of Figs. 1 and 2, and the

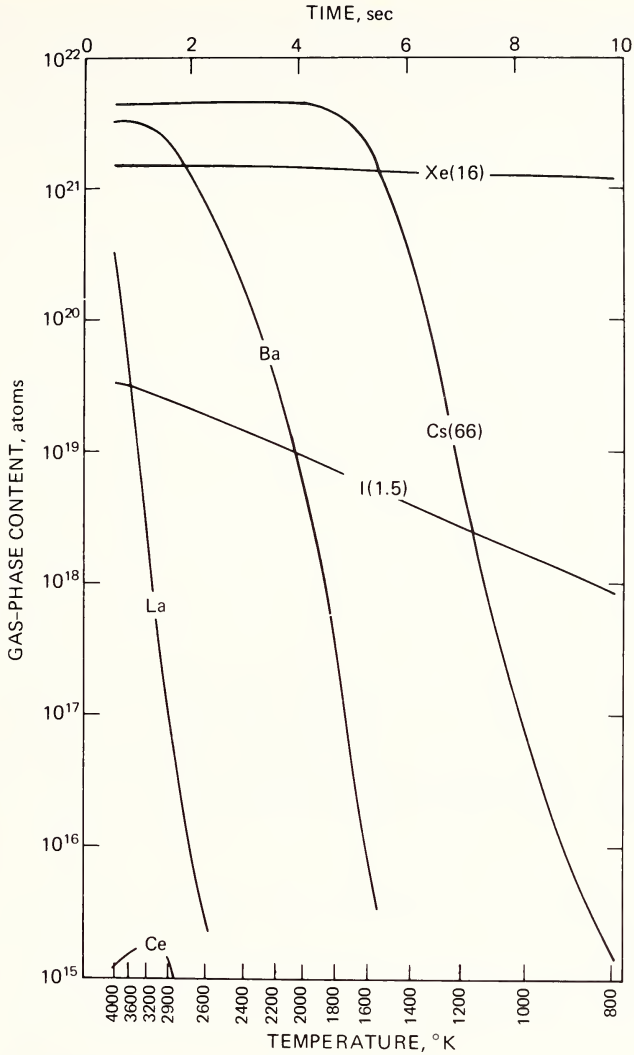

Fig. 2 Calculated gas-phase concentrations in 140 chain for Small Boy (cesium precursors and half-lives in seconds listed).

particle-size distribution is approximated on the abscissa of Fig. 3. Figure 1 shows the calculated gas-phase content of elements in the 106 chain. This figure demonstrates the early condensation of ^{106}Nb , which decayed about a factor of 2 for the calculations shown although the niobium gas-phase content dropped five orders of magnitude when it cooled to 2600°K. The condensation of molybdenum at later times is demonstrated. Molybdenum does not condense appreciably until the fireball temperature drops to 2000°K, and then the

molybdenum pressure drops sharply over the next few hundred degrees Kelvin. The moderate volatility of molybdenum is due to the species $\text{MoO}_3(\text{g})$. This figure further shows that neither technetium nor ruthenium condenses appreciably all the way down to 800°K . The volatility of $\text{RuO}_3(\text{g})$, $\text{RuO}_4(\text{g})$, $\text{TcO}_3(\text{g})$ (Ref. 9), Tc_2O_7 , or HTcO_4 [actually $\text{TcO}_3(\text{g})$ in this calculation] is thus

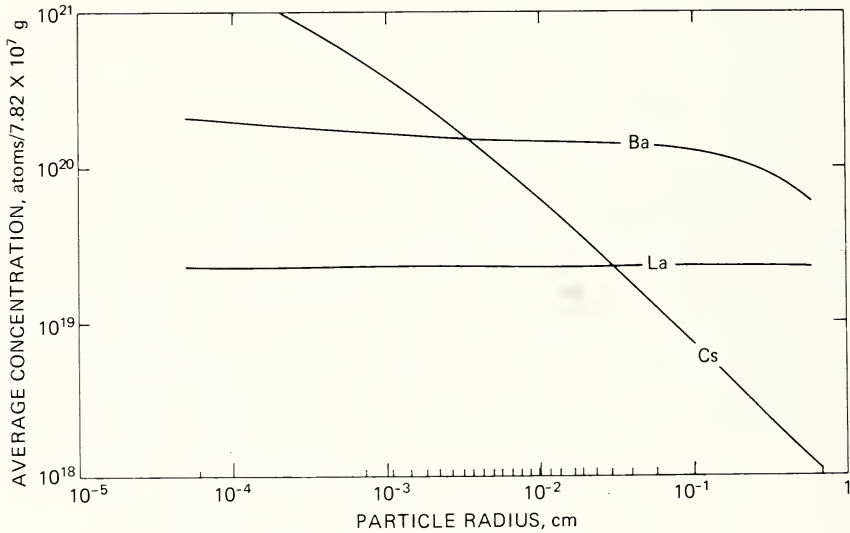

Fig. 3 Calculated 800°K concentrations for Small Boy. Each particle-size group contained 7.82×10^7 g of silicate-type fallout.

reflected. However, most of the ruthenium and technetium should condense at lower temperatures. The point is that the diffusion coefficients at temperatures below 1200 to 1400°K are so low that condensing fission products are essentially surface loaded at these temperatures. Accordingly, niobium will volume load, molybdenum will exhibit a more surface-oriented profile, and ruthenium and technetium will surface load fallout particles. Note that, in a much larger detonation than Small Boy (1.5 kt), much of the ^{106}Nb and ^{106}Mo could have decayed before the cloud cooled to condensing temperatures for these isotopes. If this were to happen, the 106 chain would be considerably more volatile since nearly 50% of the primary yield is in molybdenum and niobium. Also it is important to understand that a refractory element which has condensed at high temperature and which subsequently decays to a volatile element cannot efficiently vaporize at appreciably lower temperatures, because of condensed-state diffusion limitations.

Another interesting chain, 140, is considered in Fig. 2. The gas-content curves show lanthanum coming down at high temperatures (volume loading).

This is correct for the lanthanum existing in this time regime; however, since lanthanum is a daughter of barium and barium is a daughter of cesium, etc., the ^{140}La observed experimentally in fallout displays the properties of its precursors, and the small initial lanthanum yield is masked. Barium behaves like a fairly refractory element and will essentially volume load. However, it is a daughter of less refractory elements, and thus the barium observed in fallout is mixed in character. A moderate amount volume loads, whereas the barium from cesium exhibits a profile intermediate between volume loading and surface loading. The barium contributed from xenon and iodine is largely associated with the surface. The result of this is shown in Fig. 3, where the calculated average concentrations of lanthanum, barium, and cesium in the various-size fallout particles 9.8 sec after detonation are demonstrated. Lanthanum shows the same concentration for all size particles (volume loading), but barium exhibits a small change in concentration. For big particles the effect is a diffusion limitation of the original barium, and for small particles the increasing slope is caused by cesium's decaying to barium, a process that will later generally dominate the barium concentrations. The cesium values exhibit surface-loading characteristics. Pure surface loading in this model would be given by the average concentration's being inversely proportional to the particle radius; i.e., $C = k[4\pi r^2 / (4\pi r^3 / 3)]$. Figure 4 shows the ratio of surface concentration to average concentration of all the isotopes in a chain for various chains for the particle ensemble at 800°K , along with the remaining gaseous fraction at 800°K . Where the concentration ratio is near unity and little material is left in the gas phase, the chains will volume load. The further this is from being the case, the more highly surface loaded the chain will be. This plot is in good relative agreement with the experimental data. In an earlier paper¹⁶ a reasonable check with Small Boy data was demonstrated for the 89 chain.

This model is capable of handling various inhomogeneities. A crystalline phase can be injected at some time when the cloud is lower in temperature than the melting point of the crystals. This would correspond to some of Heft's⁸ observations. We can segment the problem so that different properties could be assumed in different sections of the cloud. Detachment of particles and cloud can be handled easily. Mathematically, intraparticle turbulence and particle agglomeration are not permitted. The question then becomes: How realistic is this model? At least we can say that it is a limiting condition. Condensation rates would not normally be considered to exceed the rates used in this condensed-state diffusion model. Under certain conditions, e.g., when a great deal of condensation was taking place, gas-phase diffusion would be rate limiting. This could slow up condensation so that fission products would be more surface sorbed than predicted with this model. It could instead be true that a condensation step would be rate limiting. In this case the final result would again predict more surface sorption. We believe that, in the absence of a complete calculational model, our condensed-state diffusion model is a good place for biological models to begin.

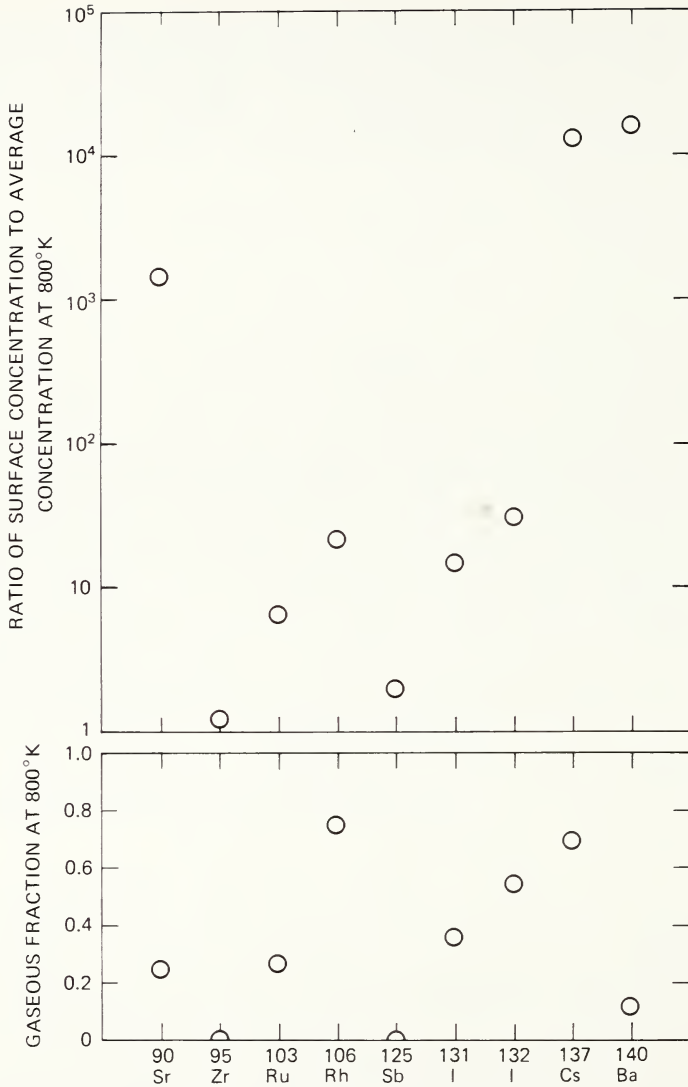

Fig. 4 Physical-chemical calculations for Small Boy.

FALLOUT-PARTICLE GRADIENT STUDIES

The condensed-state diffusion-limited model of fission-product absorption during fallout formation suggests that the concentration gradients of some radionuclides are very sharp. This is the result expected for radiocesium, for example. The importance of diffusion seems to be confirmed by the cursory experiment described in the following paragraph.

Some large silicate fallout particles from shot Johnie Boy (supplied by USNRDL) were microscopically examined and divided into two sets, uncoated particles and iron- and lead-coated particles. Three particles were selected from the uncoated set for an experiment. Their gross appearance was that of a somewhat inhomogeneous, dark glass with obvious nodules of white material on the surface. Radii, r_0 , were about 0.05 cm. The presence of radiocesium in the particles was established by gamma analysis using a multichannel analyzer and a ^{137}Cs standard for reference. After the particles were leached for 1 hr with 19% HCl, no significant loss of cesium was observed. Leaching studies were then made using 5% HF with subsequent washing, drying at 110°C for 1 hr, gamma analysis, and weighing on a microbalance. Microscopic examination of the particles throughout this process showed a continuous, but not uniform, radial attack. The experiment was concluded when the specimens lost their integrity. Results obtained in this experiment are shown in Table 1. The relative average

Table 1
COMPOSITE ^{137}Cs PROFILES IN THREE
JOHNIE BOY PARTICLES

r/r_0	$K\bar{C}$
0.973	3.4
0.921	1.8
0.880	1.6

concentration, \bar{C} , of cesium in the leached section is presented according to a calculated average radius, r , given by the weight loss. A concentration gradient is apparent in this table. Although this gradient, if we assume a uniform attack, seems small compared with the model calculations, it appears to support diffusion phenomenology.

INTERACTIONS OF FALLOUT PARTICLES WITH THE ENVIRONMENT

One of the most important properties of fallout is leachability. The chemical availability of fission-product nuclides to the biosphere is largely determined by this step. In general, the important variables in leaching are time, temperature, particle size, particle composition, the chemical nature of the leachant, degree of agitation, nature of the nuclide, and the leaching mechanism. The concentration gradient of fission products within the particle and the surface concentration of fission products are, of course, very important in establishing the leaching rate. Since this subject cannot be treated fully in this paper, treatment has been necessarily restricted to a few examples. However, it is emphasized that reliable prediction of the biological availability of fission products depends on an understanding of the diverse variables involved in leaching. The experiments

described here were performed in our laboratory. However, a large amount of pertinent information is reported in the literature, particularly in the glass and ceramics publications. For example, the studies of Douglas and El-Shamy¹⁷ indicate that leaching may occur by diffusion of the leachant through a silica-rich layer with protons or alkali ions occupying surface sites. Elliot and Auty,¹⁸ investigating the leaching of borosilicate glasses containing fission products, proposed that a layer rich in silica and fission-product oxides was formed at the glass surface. They noted that the glass durability depended on cooling rate and reported the temperature dependencies of leaching. In several examples leaching of silicates appears to follow a desorption mechanism.¹⁹⁻²¹ Löcsei²² described the importance of the degree of crystallinity in leaching of silicates.

The removal of surface-adsorbed radionuclides may be considered the simplest step in leaching of fallout. In an experiment performed to study the loss of ¹³¹I from standard glass beads (National Bureau of Standards), tellurium dioxide was neutron irradiated in a Gulf General Atomic TRIGA reactor for 250 kw-hr and then allowed to decay for approximately 50 ¹³¹Te half-lives. The sample was then heated, and the ¹³¹I, transpired by humidified oxygen, was absorbed on the 1.17- to 1.65-mm beads at near room temperature. The beads were transferred to a flask equipped with a charcoal trap, and the fractional loss of ¹³¹I from the beads in the laboratory atmosphere at room temperature was monitored by gamma analysis of the trap. The fractional release of ¹³¹I as a function of time is shown in Fig. 5. Except for small, initial rapid release, the time dependence is linear with a loss of approximately 1% in about one week. The data are described well by

$$F \times 10^3 = 0.945 + 5.58 \times 10^{-2} t \quad (1)$$

where t is time (hours). The linearity of the data in Fig. 5 is consistent with several possible release mechanisms, for instance, vaporization, vapor-phase transport, or reaction-rate control.

It is concluded that appreciable amounts of adsorbed radioiodine may be lost to the atmosphere from fallout particles at room temperature during the half-life of ¹³¹I.

After the air-release experiment, the beads were leached with distilled water to simulate rain. At intervals a small aliquot was removed, gamma analyzed, and replaced in the container. A small volume of saturated KI was then introduced, and the leaching was again monitored at various periods. The data are shown in Fig. 6. A solution of KI is apparently a better leaching agent than H₂O since it provides a direct exchange for I⁻ or a solubilizing agent for I₂. Most of the sorbed iodine could be removed with a KI solution.

Another study involved the leaching of radioiodine-doped glass with a composition of the 1450°K eutectic from the CaO-Al₂O₃-SiO₂ system. These data thus pertain to the special case of a refractory matrix containing

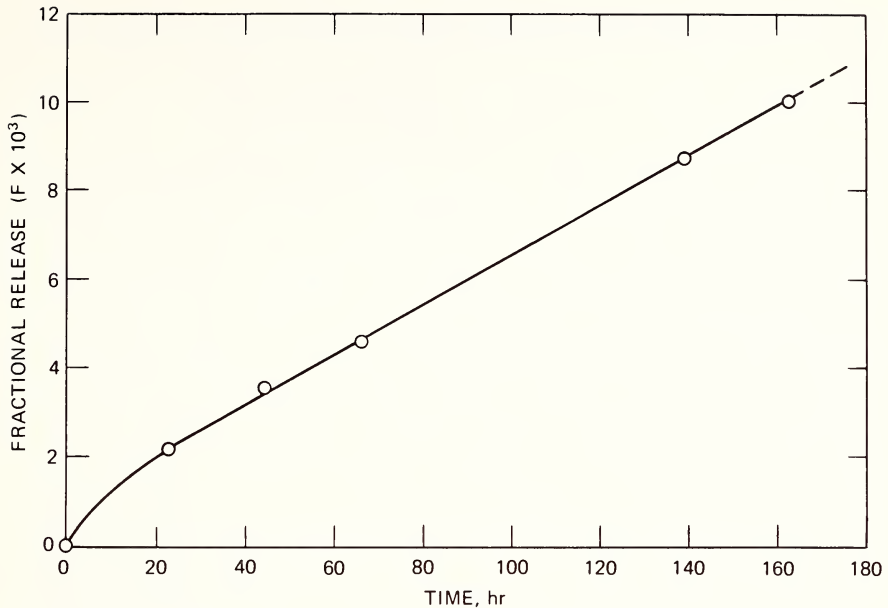

Fig. 5 Fractional release of surface adsorbed ¹³¹I by glass spheres at 298°K in laboratory air as a function of time.

homogeneously distributed radioiodine. A portion of the glass was powdered, passed through a 100-mesh screen, and dried at approximately 100°C. Weighed samples were placed in double-thickness, No. 42 Whatman filter papers, which were supported in funnels equipped for aliquoting from the tip. Periodically 5 ml of leachant were added after the previous leachant was drained, and the aliquot was made up to 50 ml and gamma analyzed with the use of reproducible geometry. Leaching was carried out at room temperature without agitation. Because of the low leaching rates, initial leaching times were about 20 min; the longest experiment lasted 2 days.

The following four leachants were used:

Leachant	pH	Remarks
HCl	2	To represent the human stomach
Tap water	8.3	Colorado River water
Deionized water	7	To represent rain water
NaOH	10	For comparison

Although the adsorption characteristics of the paper may have been important, particularly in the deionized-water experiments, the effect was assumed to be negligible. Since a surface-area measurement has not been obtained for the

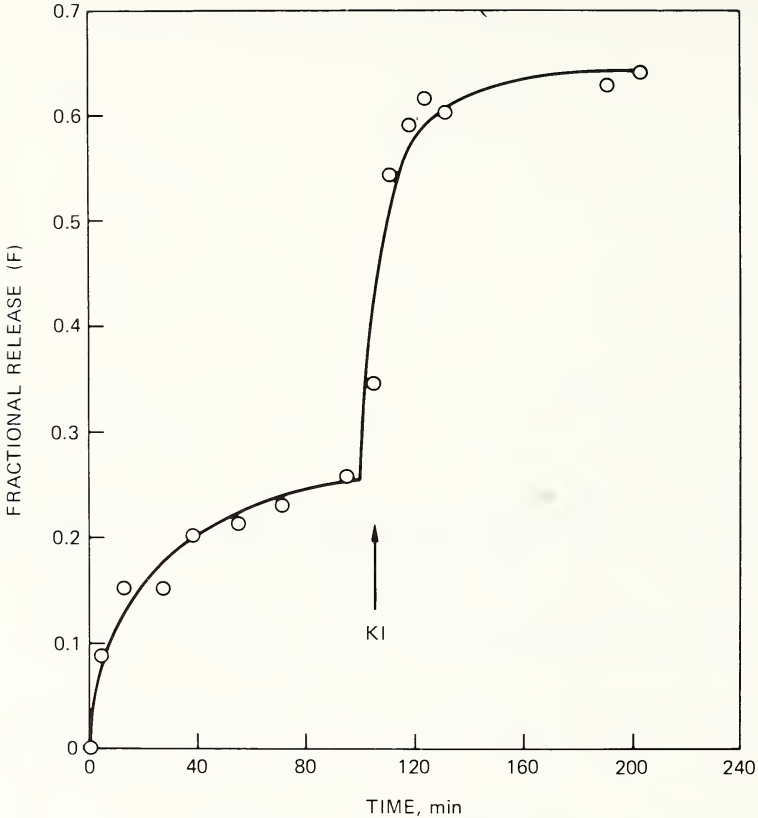

Fig. 6 Leaching of adsorbed ^{131}I from glass spheres with distilled water and potassium iodide at 298°K as a function of time.

prepared sample, the results can only be placed on a reciprocal weight basis at this time. By photomicrography the particles were found to be roughly $100\ \mu$ in "diameter."

The leaching data are shown in Fig. 7. At first it was felt that the mechanism of leaching might be diffusion-limited transport of the leachant into the matrix or of radioiodine out through the matrix. If this were the case, since only about 1% of the activity was removed, leaching should be proportional to $t^{1/2}$ (Fick's law). This dependence was not observed. However, the data can be described by the Elovich equation, which has found wide application in chemisorption:

$$\frac{dQ}{dt} = a \exp(-\alpha Q) \quad (2)$$

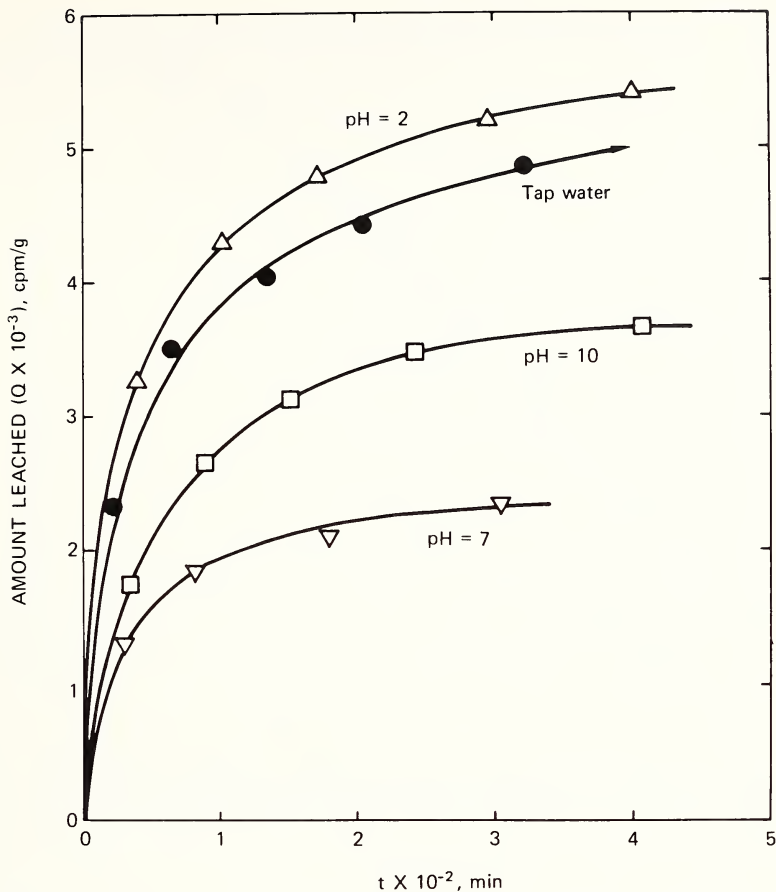

Fig. 7 Leaching of radioiodine from powdered 1450°K eutectic CaO-Al₂O₃-SiO₂ doped with ¹³¹I.

where Q is the amount of material desorbed (sorbed), t is time, and a and α are constants at fixed temperature. By assuming that $Q = 0$ when $t = 0$, we can write the integrated form:

$$\alpha Q = \ln(1 + a\alpha t) \quad (3)$$

The data can be fitted to Eq. 3 by using the values of a and α given in Table 2.

The data fitted in this manner are shown in Fig. 8, where it is seen that their agreement with the Elovich equation is good. Leaching data reported by other laboratories¹⁹⁻²¹ can also be fitted to this equation. The fact that leaching data can be fitted to the Elovich equation, at least for short times, should be regarded as an empirical fact.

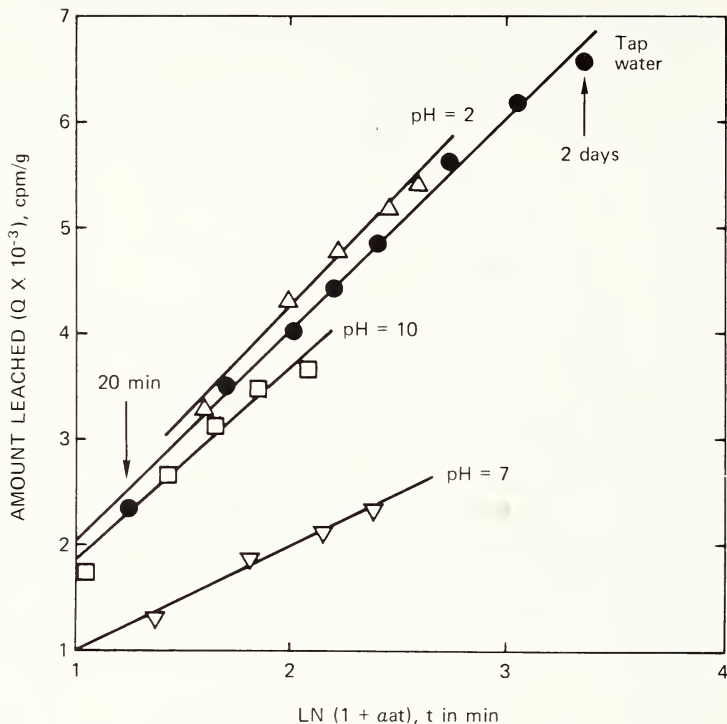

Fig. 8 Leaching of radioiodine from powdered 1450°K eutectic $\text{CaO}-\text{Al}_2\text{O}_3-\text{SiO}_2$. The data have been fitted to the Elovich equation (see text).

Table 2

COEFFICIENTS FOR THE ELOVICH EQUATION AT 300°K

Leachant	$a \times 10^{-2}$, cpm/g/min	$\alpha \times 10^3$, (cpm/g) $^{-1}$
Distilled water	3.33	2.33
NaOH	2.32	1.25
HCl	8.77	1.08
Tap water	6.62	1.15

To demonstrate further how a change in conditions can affect a change in mechanism, we performed a study of the leaching of sodium from a medium refractory glass. The matrix used for this study was purchased from the National Bureau of Standards in the form of glass spheres (Standard Reference Material

1019). The composition of this glass is similar to that of window glass. A set of standard sieves was used to screen the sample, and four subsamples were chosen. These samples are described in Table 3.

Table 3
GLASS SAMPLES USED FOR LEACHING STUDIES

Sample	Diameter, cm	Number of particles
A	0.259 to 0.236	32
B	0.236 to 0.165	39
C	0.165 to 0.117	261
D	0.117 to 0.089	530

Before they were weighed, the samples were inspected for foreign material and were briefly washed with distilled water and dried. Irregular-shaped or inhomogeneous particles were discarded. After weighing, the samples were irradiated with neutrons in a Gulf General Atomic TRIGA reactor for 250 kw-hr. A multichannel gamma analysis to 2 MeV showed peaks at 0.51, 1.37, and 1.73 MeV which can be attributed to activated sodium (pair production, primary gamma, double escape from 2.75-MeV gamma) in the glass. The samples were placed in double-thickness, No. 44 Whatman filter papers, which were held in funnels equipped for aliquoting from the tip. Colorado River tap water with a pH of approximately 8.2 was used as the leachant. Periodically 10 ml of leachant was added to the glass samples after draining of the previous aliquot, which was integrally gamma counted above 0.4 MeV. Leaching was done at room temperature without agitation. The pH of the leachant remained constant throughout the leaching periods. The overall leaching period was approximately 30 hr.

The results are shown in Fig. 9, where the total amount of activity leached per particle is plotted as a function of the square root of the time. Referring to this figure, we see that samples B, C, and D exhibited a short lag period but that the early loss by sample A was rapid. After this lag period, the losses are all linear functions of the square root of the time. The results of a least-squares fit of the data to the equation

$$Q = a + b\sqrt{t} \quad (4)$$

where Q is the amount of leached radioactivity per particle (counts per minute) and t is the time (minutes), are given in Table 4. From Table 4 and Fig. 9, the leaching mechanism for sample A appears to differ from that of the other three

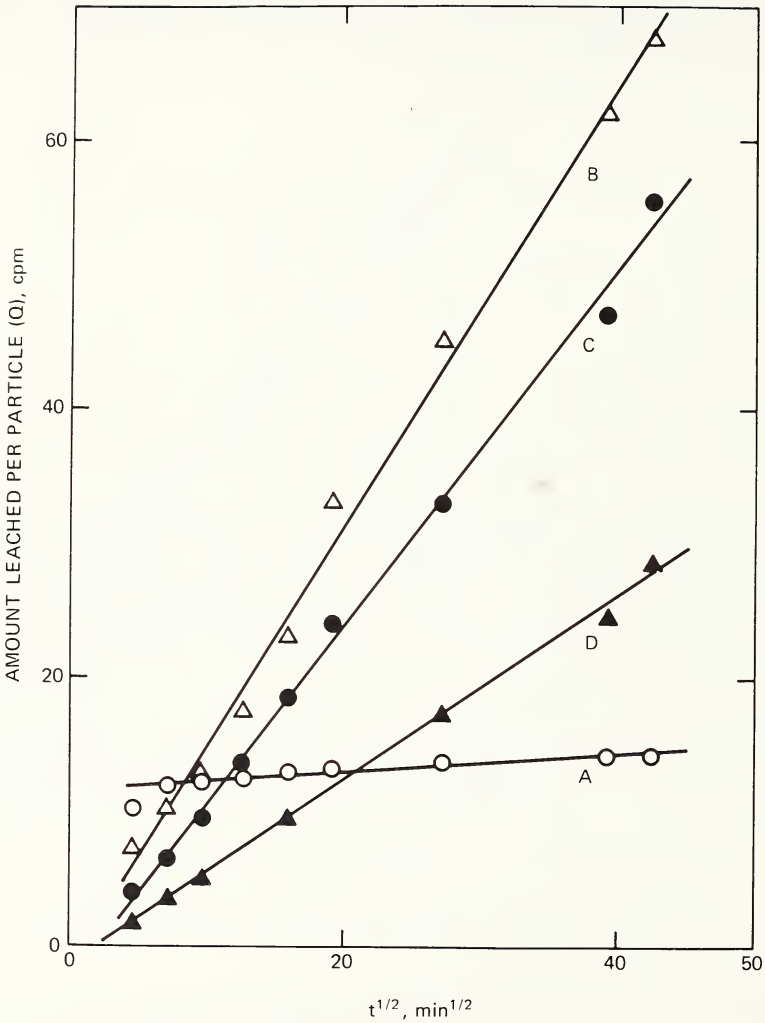

Fig. 9 Leaching of radioactivity from glass spheres by tap water as a function of the square root of the time.

samples. This result is not understood. For samples B, C, and D, the square-root time dependence indicates a diffusion mechanism. As expected, the parameter b (cpm/min^{1/2} in Table 4) increases with the particle surface area. These three samples also showed evidence of etching. The lag period may be attributed to an initially slow attack of the glass surface with respect to the interior, as was observed by Elliot and Auty.¹⁸

The fractional release of the radioactivity by samples B, C, and D may be considered on the basis of diffusion from a sphere with zero surface

Table 4
COEFFICIENTS IN EQ. 4

a, cpm	b, cpm/min ^{1/2}	Mean particle radius, cm	b/R ²
11.8	0.0644	0.124	
-1.69	1.64	0.100	164
-2.83	1.33	0.071	26.4
-1.53	0.689	0.052	25.5

concentration. Since less than 1% of the activity was lost, this process is described by^{2,3}

$$f = \frac{6}{R} \left(\frac{Dt}{\pi} \right)^{1/2} \quad (5)$$

where f = fractional release

R = radius

D = diffusion coefficient

t = time

Radius-corrected leaching "rates" are presented in the last column of Table 4 as b/R². Although it is not certain that sodium-ion migration is the rate-controlling process, these data suggest this to be the case. From these data and from initial specifications, the average value of D associated with a sodium-ion-migration mechanism was calculated to be 2.2×10^{-11} cm²/sec.

A different matrix would probably yield different results. As an example, Lőcsei^{2,2} studied the leachability of a Na₂O-CaO-MgO-Al₂O₃-SiO₂ system using 10% HCl. The character of the matrices ranged from 100% vitreous to 100% crystalline. His data are described well by an equation of the form

$$S = ae^{-bx} \quad (6)$$

where S is the solubility (grams per square meter per day), x is the percentage of crystallinity, and a and b are constants. The effect of crystallinity was pronounced, being roughly two orders of magnitude in S.

Another of our studies involved the leaching of recoil-loaded glasses. The recoil loading was done to simulate fallout containing high radionuclide concentrations near the particle surface as described by the Korts-Norman fallout model.⁴

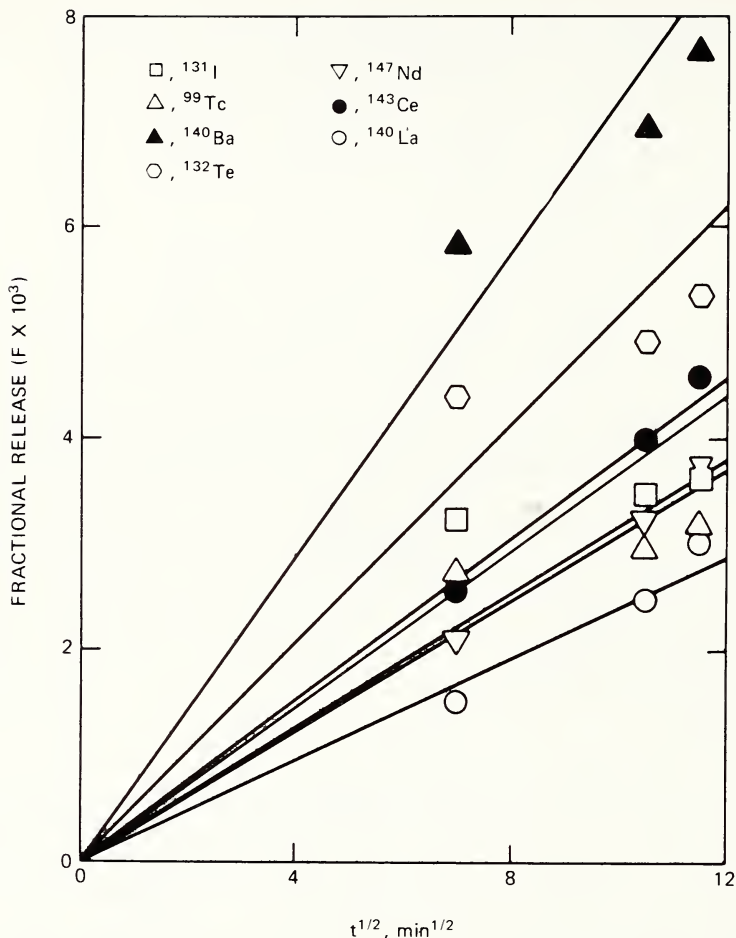

Fig. 10 Fractional release of fission products from eutectic glass during leaching; the average uncertainty is 15%.

Two silicate matrices were used, vitreous Nevada soil and the glass of 1450°K eutectic composition from the $\text{CaO}-\text{Al}_2\text{O}_3-\text{SiO}_2$ system. The glasses were treated by heating them on flat platinum surfaces for several hours at 1400°C in air. A small piece of fully-enriched uranium foil was placed between the two flat glass surfaces when they had cooled, and the sample was irradiated with neutrons in a Gulf General Atomic, Inc., TRIGA reactor for 125 kw-hr. The radioactivity was allowed to decay for approximately 5 days. Then the glasses were separated from the foil and were lightly cleaned with fine carborundum paper to eliminate spalled uranium and fission products from the surfaces. After being cleaned and dried, the samples were subjected to leaching at room temperature in plastic beakers containing 5 ml of a slurry of 11.5 g of

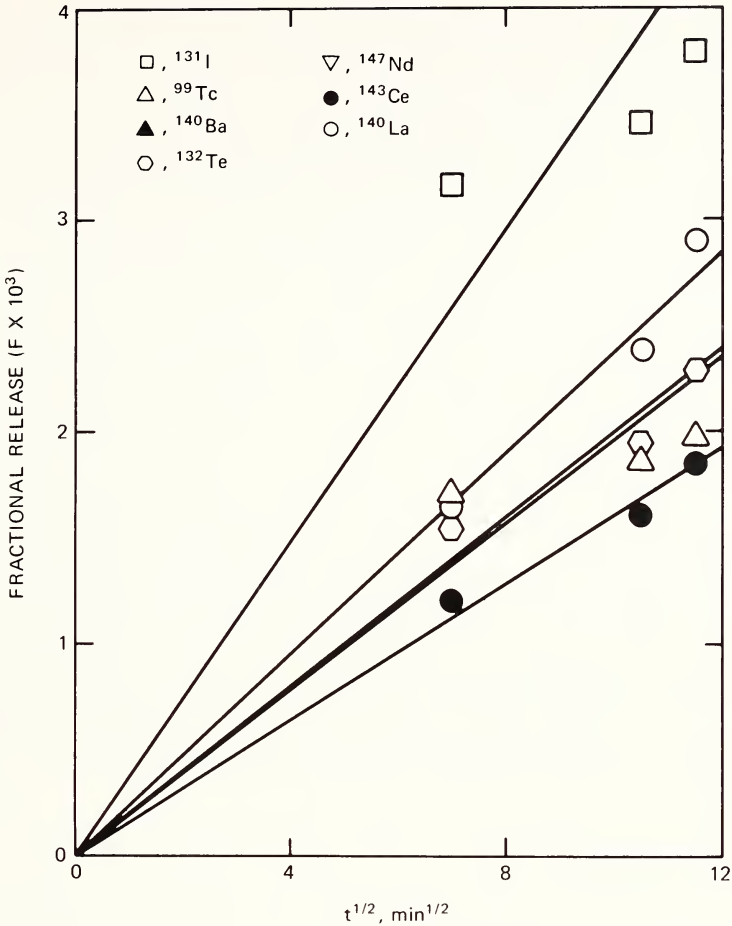

Fig. 11 Fractional release of fission products from Nevada glass during leaching; the average uncertainty is 25%.

montmorillonite in 750 ml of distilled water. The clay was used to provide an efficient sink for leached fission products. During leaching both the glasses and the leaching slurries were separately analyzed with a 4096-channel gamma analyzer equipped with a lithium-drifted germanium detector. The gamma spectra were then corrected by referring them to the irradiation time using the pertinent half-lives. Several nuclides were found in all spectra for the leaching slurries and for both glasses.

The data are shown in Figs. 10 and 11, where the fractional releases of the glasses are plotted as functions of the square root of the time. From these figures the leaching process appears to be one of diffusion during the leaching period of 132 min. Several qualitative conclusions may be made concerning these data.

Since the fractional releases are not highly correlated with mass number (recoil ranges are highly correlated with mass), the leaching process is not totally dependent on the recoil distribution of fission products. The approximate leaching penetration during the experiment can also be calculated. Assuming a recoil range of $10\ \mu$ for a nuclide in the eutectic glass and using a fractional release value of 5×10^{-3} for this nuclide, we calculate a penetration distance of approximately $200\ \text{\AA}$. Thus for volatile chains the degree of surface loading can play a dominant role in subsequent leaching. In the present study leaching rates differ by up to a factor of about 4 for all the nuclides studied in the two glasses. The reason for differences between nuclides is not known, but, if diffusion is rate controlling, such differences are expected. It is also observed that the order of leaching rates of different nuclides from the eutectic glass differs from that of the Nevada glass, and, surprisingly, the leaching rates are only slightly different for the two glasses. This is consistent with the similarity of these two glasses in high-temperature diffusion studies.

Considering the studies reported in this section, it appears unlikely that any a priori unified scheme of transfer of radionuclides from fallout particles to the biosphere can be established now. Such a scheme would require the output of a model such as Korts and Norman have described. It would also require a good physical-chemical model involving chemical attack on fallout particles and migration of radionuclides in many environments. This latter task is formidable. It is not true that simple models to describe leaching of fallout should not be devised. This is exactly what should be done. However, these simple models should strive for as much realism as possible, and, in view of our present knowledge, we are quite limited, particularly in the leaching model.

ACKNOWLEDGMENT

This work was supported by the Department of the Army, Office of Civil Defense, under Contract DAHC20-70-C-0388.

REFERENCES

1. E. C. Freiling, Fractionation. I. High-Yield Surface Burst Correlation, Report USNRDL-TR-385, U. S. Naval Radiological Defense Laboratory, Oct. 29, 1959.
2. E. C. Freiling, G. R. Crocker, and C. E. Adams, Nuclear-Debris Formation, in *Radioactive Fallout From Nuclear Weapons Tests*, Proceedings of the Second Conference, Germantown, Md., Nov. 3-6, 1964, A. W. Klement (Ed.), AEC Symposium Series, No. 5 (CONF-765), pp. 1-43, 1965.
3. C. F. Miller, Fallout and Radiological Countermeasures. Volume I., Report AD-410522, p. 26, Stanford Research Institute (Project No. IM-4021), 1963.
4. R. F. Korts and J. H. Norman, A Computational Model for Condensed State Diffusion Controlled Fission Product Absorption During Fallout Formation, Report GA-7598, General Dynamics Corp., General Atomic Div., Jan. 10, 1967.

5. E. C. Freiling, Mass-Transfer Mechanisms in Source-Term Definition, in *Radionuclides in the Environment*, Advances in Chemistry Series, No. 93, pp. 1-12, American Chemical Society, Washington, D. C., 1970.
6. M. W. Nathans, R. Thews, and I. J. Russell, The Particle Size Distribution of Nuclear Cloud Samples, in *Radionuclides in the Environment*, Advances in Chemistry Series, No. 93, pp. 360-380, American Chemical Society, Washington, D. C., 1970.
7. R. C. Tompkins, I. J. Russell, and W. N. Nathans, A Comparison Between Cloud Samples and Close-In Ground Fallout Samples from Nuclear Ground Bursts, in *Radionuclides in the Environment*, Advances in Chemistry Series, No. 93, pp. 381-400, American Chemical Society, Washington, D. C., 1970.
8. R. E. Heft, The Characterization of Radioactive Particles from Nuclear Weapons Tests, in *Radionuclides in the Environment*, Advances in Chemistry Series, No. 93, pp. 254-281, American Chemical Society, Washington, D. C., 1970.
9. J. H. Norman, Henry's Law Constants for Dissolution of Fission Products in a Silicate Fallout Particle Matrix, Report GA-7058, General Dynamics Corp., General Atomic Div., Dec. 29, 1966.
10. P. Winchell and J. H. Norman, A Study of the Diffusion of Radioactive Nuclides in Molten Silicates at High Temperatures, in *High Temperature Technology*, Proceedings of the Third International Symposium, Asilomar, Calif., Sept. 17, 1967, p. 479, Butterworth & Co. (Publishers) Ltd., London, 1969.
11. C. E. Adams, J. T. Quan, and W. R. Balkwell, High Temperature Measurements of the Rates of Uptake of Molybdenum Oxide, Tellurium Oxide, and Rubidium Oxide Vapors by Selected Oxide Substrates, in *Radionuclides in the Environment*, Advances in Chemistry Series, No. 93, pp. 35-62, American Chemical Society, Washington, D. C., 1970.
12. E. W. Bloore, R. F. Benck, D. A. Furey, P. C. Harris, B. L. Houseman, and L. A. Walker, The Mechanisms of Fallout Particle Formation, Annual Progress Report for Period Ending April 1969, Report NDL-SP-36, U. S. Army Nuclear Defense Laboratory, 1969.
13. I. J. Russell, Fundamental Studies in Fallout Formation Processes, Progress Report, June 1, 1967, to May 31, 1968, USAEC Report NYO-3756-2, Boston College, June 1, 1968.
14. S. Z. Mikhail, Beta-Radiation Doses from Fallout Particles Deposited on the Skin, this volume.
15. J. H. Norman, P. Winchell, H. G. Staley, M. Tagami, and M. Hiatt, Henry's Law Constant Measurements for Fission Products Absorbed in Silicates, in *Thermodynamics of Nuclear Materials, 1967*, Symposium Proceedings, Vienna, 1967, p. 209, International Atomic Energy Agency, Vienna, 1968 (STI/PUB/162).
16. J. H. Norman, P. Winchell, J. M. Dixon, B. W. Roos, and R. F. Korts, Spheres: Diffusion-Controlled Fission Product Release and Absorption, in *Radionuclides in the Environment*, Advances in Chemistry Series, No. 93, pp. 13-35, American Chemical Society, Washington, D. C., 1970.
17. R. W. Douglas and T. M. M. El-Shamy, Reactions of Glass with Aqueous Solutions, *J. Amer. Ceram. Soc.*, **50**: 1-8 (1967).
18. M. N. Elliot and D. B. Auty, The Durability of Glass for the Disposal of Highly Radioactive Wastes: Discussion of Methods and Effect of Leaching Conditions, *Glass Technol.*, **9**: 5-13 (1968).
19. J. Ralkova and J. Saidl, in *Treatment and Storage of High-Level Radioactive Wastes*, Symposium Series, Vienna, 1962, p. 347, International Atomic Energy Agency, Vienna, 1963 (STI/PUB/63).
20. R. Bonniaud, C. Sombret, and F. Laude, in *Treatment and Storage of High-Level Radioactive Wastes*, Symposium Series, Vienna, 1962, pp. 366-368, 372-373, International Atomic Energy Agency, Vienna, 1963 (STI/PUB/63).

21. W. E. Clark and H. W. Godbee, in *Treatment and Storage of High-Level Radioactive Wastes*, Symposium Series, Vienna, 1962, p. 430, International Atomic Energy Agency, Vienna, 1963 (STI/PUB/63).
22. B. P. Lőcsei, Acid Resistance of Vitroceramic Materials on a Feldspar-Diopside Base, in *Symposium on Nucleation and Crystallization in Glasses and Melts*, p. 71, American Ceramic Society, Columbus, Ohio, 1962.
23. J. Crank, *The Mathematics of Diffusion*, p. 87, Oxford University Press, London, 1956.

BETA-RADIATION DOSES FROM FALLOUT PARTICLES DEPOSITED ON THE SKIN

S. Z. MIKHAIL

Environmental Science Associates, Burlingame, California

ABSTRACT

Absorbed beta-radiation dose expected from fallout particles deposited on the skin was estimated by use of the Beta Transmission, Degradation, and Dissipation (TDD) model. Comparison of computed doses with the most recent experimental data relative to skin response to beta-energy deposition leads to the conclusion that, even for fallout arrival times as early as 10^3 sec (16.7 min postdetonation), no skin ulceration is expected from single particles 500μ or less in diameter.

Doses from arrays of fallout particles of different size distributions were computed also for several fallout-mass deposition densities; time intervals required to accumulate doses sufficient to initiate skin lesions were calculated.

In 1954 residents of Rongelap Atoll in the Marshall Islands were exposed to fallout arriving within hours after detonation of the Castle Bravo nuclear device. Several of the atoll's inhabitants suffered severe skin burns. Primarily as a result of this experience, the possibility of "beta burn" from nuclear fallout has been recognized. However, to date, attempts to predict the acute or chronic skin effects that might be expected following exposure to fallout have been limited. This limitation results mainly from the lack of experimental data on the biologic response of the skin to particulate-source exposures, from incomplete understanding of the relation of such response to that encountered in other localized exposures (e.g., collimated X-ray beams) for which data are available, and from the absence of reliable beta-dose calculational models. All these are required to relate dose to observed effect in a manner allowing prediction of the biological effects from knowledge of the expected fallout interaction.

The literature indicates that work on the theoretical aspects of the beta-dose problem has progressed faster than have experimental efforts. As early as 1956 Loevinger, Japha, and Brownell devised an analytical representation (model) to calculate beta doses from "discrete radioisotope sources."¹ By 1966 four models

were available.² The most precise, though complex, of these models is the Transmission, Degradation, and Dissipation (TDD) model.² This paper is based on the TDD model and presents predicted beta doses that would result from skin deposition of nuclear-weapon fallout particles.

A nuclear attack on the United States would be expected to result in low-intensity gamma-radiation fields over much of the fallout area that would develop. Exposure to the low-intensity field would pose little or no immediate or long-term whole-body gamma-radiation hazard. However, it has been suggested that in such situations contact of individual fallout particles with exposed skin could constitute a potential hazard. Individual particles can deposit on the skin via direct deposition during passage of the fallout cloud or following resuspension of particles at a later time.

Each particle, if radioactive enough, is capable of producing a lesion. If several particles reside close enough in the same general skin area, their effects could be additive, in the sense of causing one lesion. However, at larger particle-separation distances, beta-radiation dose deliveries would not interact. That is, the dose contribution from one particle to the tissue in the vicinity of another particle would be negligible. This situation is treated separately in the next three sections. At small particle-separation distances, estimation of the dose delivered at any point in tissue would require summation of the dose contributions from all particles in the immediate vicinity. This latter situation is treated separately also.

THE SINGLE-PARTICLE BETA-DOSE MODEL

The TDD model for single particles is composed of six separate semi-independent computer codes. The first (Code 1) is a nuclide-abundance code that calculates the activity of each radionuclide generated in the detonation of a nuclear device or weapon. This code also considers radioactive decay and calculates fission-nuclide activity at any postdetonation time.

Code 2 computes the beta spectrum for each beta-emitting nuclide, given the end-point energies, beta branching fractions, and degree of forbiddenness of the beta transitions.³ Output from this code is a sequence of values representing the probability that a beta particle will be emitted with an energy between E and $E + \Delta E$, where $\Delta E = 0.04$ MeV and values for E range from 0 to the maximum β energy, E_{max} . Individual fission-product beta spectra have been generated and are stored on tape for use with the composite-spectrum code (Code 3).

Code 3 is a composite-spectrum routine that sums the individual beta spectra of the fission-product nuclides with appropriate weighting for the activity of each contributing nuclide, as determined by Code 1. Code 3 produces a point-source beta spectrum at a given time for the specific weapon under consideration. Output from this code is a sequence of values representing the number of betas per energy interval emitted by the source.

The electron spectrum from a fallout particle (assumed to be spherical in shape) differs from that produced by a point source because scattering and absorption processes within the particle degrade the spectrum. Calculation of the extent of degradation is complicated by the fact that in fallout particles some fission products are uniformly distributed within the particle material, others have condensed on the particle surface, and the rest behave in an intermediate fashion.⁴

Korts and Norman developed a model,⁵ termed the Condensed State Diffusion Controlled Model, which describes the mechanism of fission-product absorption in fallout material distributed in a radioactive cloud following a nuclear detonation. In this model they assumed that (1) the fallout material is glassy silicate; (2) the surface of a fallout particle is in equilibrium with the gas phase; and (3) the rate of transfer of fission products into the interior of the fallout particle is diffusion controlled. One output of this Condensed State Diffusion Controlled Model consists of a set of radial fission-product-concentration profiles in fallout particles of different sizes. Using such concentration profiles, Korts and Norman calculated for each fission product the percentage of total nuclide present which would diffuse into the particle. In almost all cases examined, they found that "loadings" of 0, 25, 50, 62.5, 75, 82.5, and 100% (by weight) could be used to describe the portion of fission product present diffusing into the particle. (The complementary percentage in each of the seven classes represents the portion of the fission product present that remains at the particle surface.) Zero percent diffusion takes place when the fission product condenses on the particle surface, essentially without any diffusion during particle cooling; whereas 100% diffusion represents complete diffusion leading to homogeneous distribution of the fission product in the silicate matrix. This Condensed State Diffusion Controlled Model was used in the manner described in the following paragraph to provide the geometric basis for the electron degradation within fallout particles.

Degradation suffered by the emanating electron spectrum is handled by Code 4, a Monte Carlo program that starts with a given number of emitted betas in a specified energy interval and then computes the loss in electron energy and number due to scattering and absorption processes within the particle. The code outputs two sets of Monte Carlo determined energy-dependent loss coefficients, set A for homogeneously distributed fission products and set B for surface-condensed fission products. These coefficients are then applied to the composite beta spectrum from the point source of fission products (Code 3) by Code 5. Application of these loss factors is straightforward for the 0 and 100% diffusion cases (in which set B and set A, respectively, are utilized). For five intermediate diffusion cases, set A was applied to the percentage diffusing into the particle, and set B was applied to the percentage remaining at the surface. Output of Code 5 thus consists of a degraded beta spectrum emerging from a fallout particle of a specified size.

Code 6 operates on the resulting composite degraded spectrum to compute the depth-dose rate in tissue. This is based on energy-dissipation factors for fast electrons as calculated by Spencer.⁶

The dose rate, D_τ (in rads per hour), at a tissue depth Z centimeters from a particle of volume V (in cubic centimeters) emitting $N_e(E_0)$ beta particles per second per cubic centimeter in the energy interval ΔE with mean energy E_0 (in million electron volts) (this is the emerging degraded spectrum in the present work) is given by:

$$D_\tau = \frac{kfgV}{4\pi Y^2} \sum_{E_0=\Delta E/2}^{E_0=E_{\max}-\Delta E/2} J(x) (dE/dr)_{E_0} N_e(E_0) \quad (1)$$

where k = a constant, 5.76×10^{-5} (rad-g-sec)/(MeV-hr), relating energy-transport rate to dose rate

f = dimensionless correction factor for a semi-infinite absorber, determined from an auxiliary Monte Carlo program

g = ratio of dose rate at a distance Y (in centimeters) from the center of a spherical source (radius R in centimeters) to the dose rate from a point source at the same distance ($Y > R$); the ratio is a dimensionless quantity given by

$$g = \frac{3Y^2}{R^2} \left[0.5 + \left(\frac{R^2 - Y^2}{4RY} \right) \ln \left(\frac{Y + R}{Y - R} \right) \right] \quad (2)$$

$J(x)$ = Spencer's energy-dissipation-distribution function evaluated at tissue depth Z measured in units of the normalizing residual range, r_0 ;
 $x = z\rho/r_0$, ρ being the density of the absorbing medium⁶

$(dE/dr)_{E_0}$ = stopping power of the absorber for electrons emitted from the particle with energy E_0

The resulting dose rates, summed over the composite degraded spectrum, form the output of this part of the model.

The final operation of the composite TDD model integrates the various dose rates (from each energy interval) computed via Eq. 1 over time to get the total absorbed dose. In practice, to reduce computation time, we carry out the integration by the use of time-integrated beta activities derived from the inventory code (Code 1) to make up a time-integrated composite beta spectrum. This spectrum is then degraded and deposited in tissue as explained previously; i.e., the time integration is done from the start rather than as the last step.

Recently the six codes have been unified into a single modified composite program to reduce computer run time.⁷ Also, several new features have been introduced into the composite program to increase its ability to cope with a variety of beta-dose problems.⁸

EVALUATION OF THE SINGLE-PARTICLE MODEL

Validity of the TDD-model dose predictions has been examined⁸ by comparing the model-computed doses delivered by reactor-irradiated UC_2 particles with (1) doses from the UC_2 particles measured with a β -extrapolation chamber;⁹ (2) values for UC_2 particle dose obtained by a photographic-film dosimetry technique; and (3) dose values computed by applying a completely independent Monte Carlo calculational technique.

Tests included doses at shallow as well as at relatively large depths (7500μ) in tissue and at points directly underneath the particle and points radially displaced to distances as far as 5000μ . Particles of variable sizes and reactor irradiation times of different duration were also included in the comparisons.

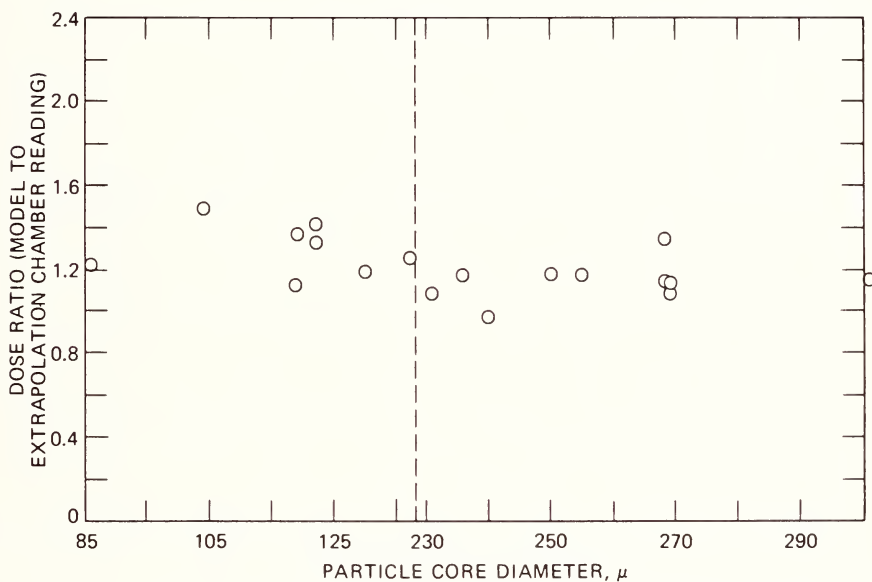

Fig. 1 Ratio of calculated (TDD model) dose to dose measured with a β -extrapolation chamber (tissue depth, 30μ).

Typical results obtained in the comparisons with data from the extrapolation chamber, the Monte Carlo program, and the photographic-film exposure technique are presented in Figs. 1, 2, and 3, respectively. The primary conclusions drawn from the comparisons were:⁸

1. On the whole, agreement between values obtained by use of the composite program and those obtained by experimentation and exercise of the cited Monte Carlo program was satisfactory.

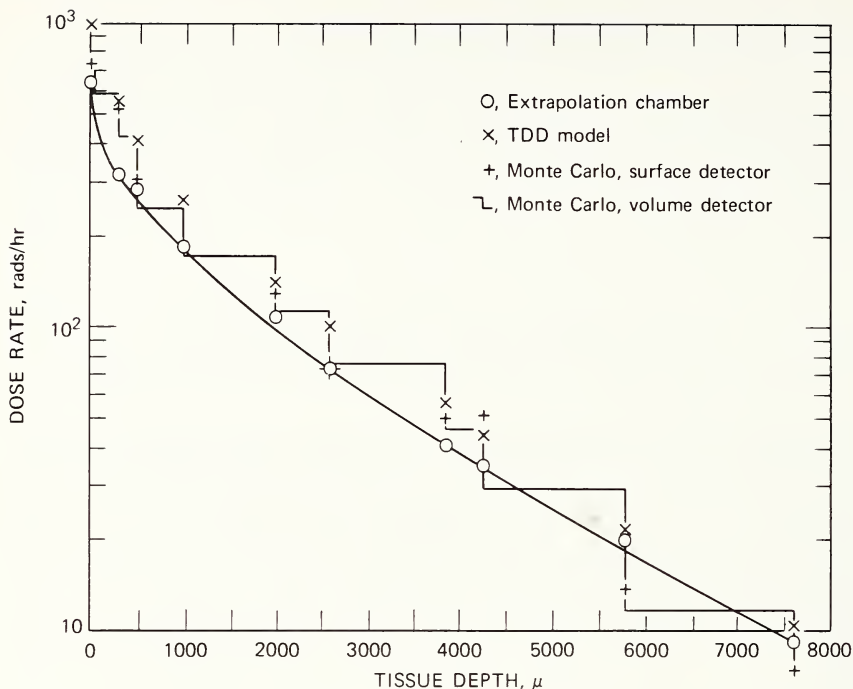

Fig. 2 Comparison of TDD model calculations with Monte Carlo calculations and extrapolation-chamber measurements (delay time, 5.75 hr).

2. The ranges of particle sizes (85 to 310 μ) and time periods of reactor irradiation (5 min to 24 hr) considered appear to have little influence on the extent of agreement achieved.

3. Tissue beta-radiation delivery (i.e., absorption) estimated by the composite TDD model for shallow tissue depths is invariably higher than that derived from the Monte Carlo calculations. As the tissue depth considered increases, agreement between the TDD model and experimental results improves until, as shown in Fig. 4, at a tissue path length of about 4000 μ the values for the model and those for the test method tend to agree. Such relations are interpreted to indicate that the model underestimates electron attenuation in the particle material and overestimates that in tissue.

4. Delay times (time periods between termination of reactor irradiation and start of tissue exposure) greater than approximately 25 hr appear to increase the difference between model predictions and values determined by the test methods, but not to an appreciable degree.

5. Doses measured directly below the particle by photographic-film experiments agree rather well with model predictions, except for dose locations very close to the particle, in which case apparent saturation of film occurs.

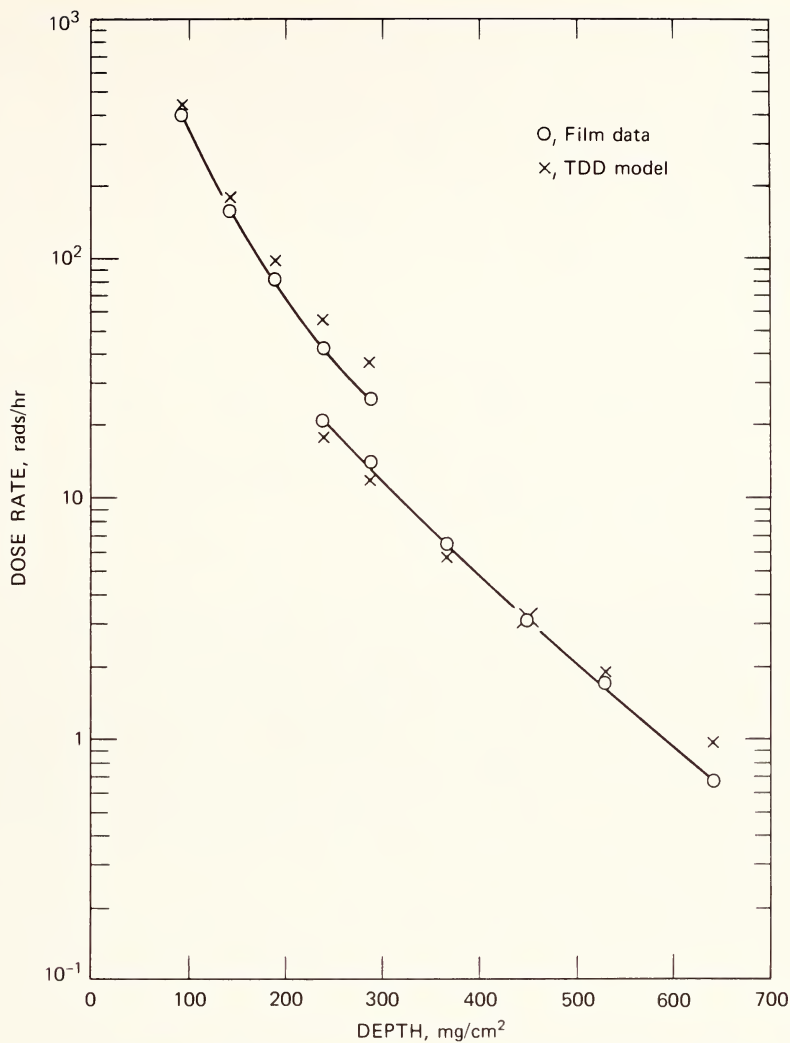

Fig. 3 Comparison of calculated (TDD model) dose rates with film data (160- μ particles).

DOSE CRITERIA FOR SINGLE-PARTICLE EXPOSURE

Serious acute lesions of the skin are induced primarily by the destruction of the germinal cells of the epithelium. In humans the subsurface depth of the skin germinal-cell layer varies from 20 to 250 μ . However, for convenience a single depth of 100 μ is usually chosen to represent the critical level. The absorbed beta dose (or amount of beta energy absorbed in an infinitesimally small mass of

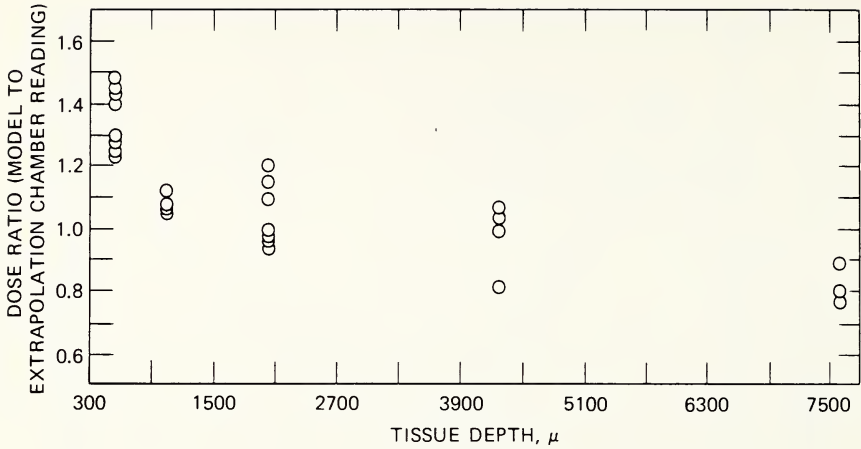

Fig. 4 Ratio of model (TDD) dose to extrapolation-chamber dose, as a function of tissue depth (236- μ particles).

tissue surrounding the point of interest) at a point 100 μ deep “underneath” the source (fallout particle) is termed the “point depth dose” at 100 μ .

For a considerable period of time, beta-radiation damage to skin was viewed almost entirely in terms of the estimated 100- μ point depth dose. However, in recent years it has become generally accepted that for a serious radiation lesion to occur the germinal cells must be destroyed over an area of skin too large for normal regeneration to replace them within a reasonable period of time. Of necessity this has led to consideration of area dose absorption rather than dose absorbed at a specific point.

A survey by Krebs¹⁰ in 1967 showed that, for an acute lesion of the skin to develop, the viable germinal cells must be reduced to a survival level of less than 0.001 over an area sufficiently large to prevent replacement of dead cells via cell proliferation in the margin of the exposure field. The criterion recommended by Krebs is that a 1500-rad or greater dose to the skin, deposited on the periphery of a 4-mm-radius circular field 100 μ deep in tissue, constitutes a potential skin-damage threat.

Krebs derived his conclusions from X-ray microbeam studies. At the time of his evaluation, few biological-damage data were available from single-particle investigations. After Krebs's conclusions were published, an experimental study testing the suggested criterion was conducted.¹¹ Irradiated microspheres were used as radiation sources, and swine were the experimental animals. Results obtained in this study showed that the minimum radiation dose, deposited at the periphery of a 4-mm-radius field, required to produce a very small ulcer (less than 0.5 mm in diameter) is estimated to be below 405 rads. An ulcer 1 mm in diameter was produced by absorption of 660 rads (same field), a 2-mm-diameter

ulcer by about 1150 rads, etc. If we assume linearity of the ulcer diameter with dose (4-mm-radius field), as indicated by the data, then by extrapolation a 350-rad delivery would be sufficient to yield a zero-diameter ulcer.

In this work the 660-rad dose was used as the threshold dose for damage to human skin from deposited fallout particles. This admittedly arbitrary threshold was chosen on the basis that a 1-mm-diameter ulcer is small enough to be considered a threshold for damage but large enough to be recognizable. Choice of 350 or 1150 rads as a threshold dose does not appreciably affect the conclusions derived.

THE MULTIPLE-PARTICLE BETA-DOSE MODEL

The multiple-particle beta-dose model is designed for evaluation of dose situations in which the fallout-particle deposition density on the skin is of such magnitude that beta radiation emitted from adjacent particles is absorbed in the same tissue volume.

Two distinct approaches can be used to examine the absorbed dose from multiparticle sources. In the first the source is viewed as a uniform plane source of strength dependent only on the number of "equivalent fissions" of fission products deposited per unit area. In the more realistic second approach, the source is taken to be a group of fallout particles of size distribution dependent on the weapon yield and the distance from ground zero to the deposition point of interest. The beta dose delivered by such a source to the skin depends, in addition to the particle-size distribution, on the fallout mass deposited per unit area and on the specific activity of the fallout.

The plane-source approach was pursued by Brown,¹² who used Spencer's plane-source calculations to compute beta-dose-rate multipliers for each fission-product beta emitter. Brown considered two situations: (1) contact dose, where the plane source lies between an absorbing medium and a backscatterer, and (2) beta bath, where an attenuation medium separates the absorbing medium from the plane source.

Using Brown's contact-dose multipliers and the output from the abundance code (Code 1) of the TDD program, we can calculate the dose delivered to the skin from a plane source of the desired activity level. Results of these computations are considered later.

In the second, or particulate, model, the source is viewed, for purposes of analytical examination, as consisting of superimposed strata of fallout particles, each stratum being in contact with the skin surface. Each stratum consists of an array of equal-size particles with separate particles placed at the intersections of a uniform rectangular-plane grid. Figure 5 illustrates the concept. The dose is estimated at point X, 100 μ below the central point of the grid plane. The dose at X can be determined by summation of the dose contributions from individual particles as computed by the TDD model.

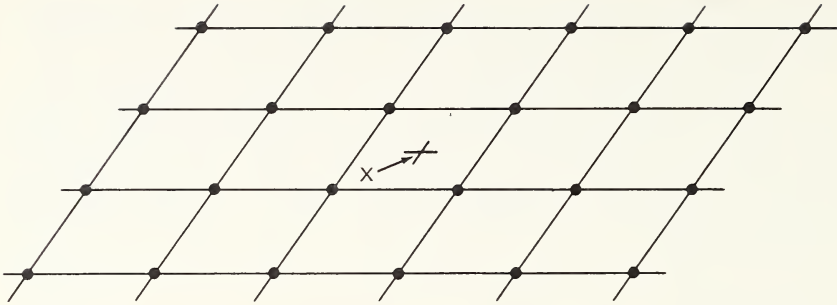

Fig. 5 Schematic of the multiple-particle array concept.

Dimensions of the unit cell of the grid are determined by the mass deposition density (in grams of fallout per square foot) and the size class of particles forming the grid. For a relatively large array of closely spaced particles, the dose at any point 100μ below the plane becomes very close to the dose at X .

For calculation of the dose at X , dose contributions from the particles closest to X are computed and added. Then doses from particles at increasing distances from X are added until the incremental increase in dose falls below a predetermined fraction of the initial sum, at which time the calculation stops.

For accuracy, 10 strata of arrays were considered in the calculations. Each stratum was assumed to contain 10% of the total fallout mass deposited (on a unit-area basis). Particle sizes for the arrays were determined by the following procedure:

1. Assume a mean and a maximum particle size for the fallout deposit. In the first four situations considered, take the means parametrically as 100, 250, 500, and 700μ each with a fixed maximum of 1000μ . In a fifth case take the mean as 1000 and the maximum as 2000μ .

2. Assuming a log-normal distribution⁴ of particle sizes in each case, and with the knowledge of the maximum and the mean, trace a log-probability line for the particle-size distribution.

3. Subdivide the line into 10 equal-probability regions and determine for each region the particle size, corresponding to the midrange probability. Use these 10 mean particle sizes for the strata.

Two facts are worth mentioning here. (1) For obvious reasons, the particulate approach is much more realistic than the plane-source approach. (2) For the same number of equivalent fissions per unit area, the plane-source computations give dose values higher than the Multiparticle Model by as much as an order of magnitude (see Fig. 6). The discrepancies are apparently chiefly due to attenuation within particles. The detailed differences between the dose values resulting from the two approaches depend on the particle-size distribution

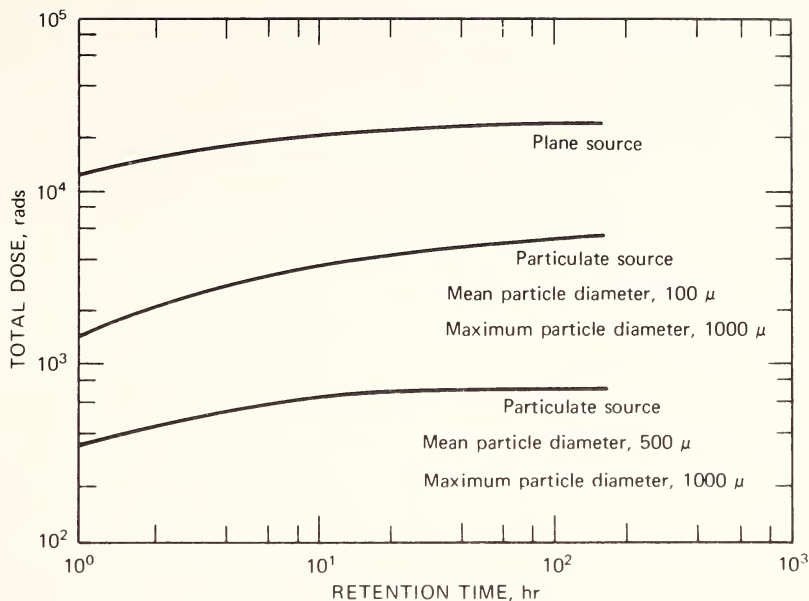

Fig. 6 Comparison between doses computed for a plane source and the corresponding values for a multiparticle source. Tissue depth, 100μ ; delay time, 10^3 sec; deposition density, 100 mg/sq ft ; activity, 10^{15} fissions/cc.

assumed in the particulate approach (Fig. 6). For a fixed maximum size, the difference decreases as the mean particle size decreases, but a factor of 5 was the smallest encountered for the cases considered.

DOSE CRITERIA FOR MULTIPLE-PARTICLE DEPOSITION

To date no criterion has been explicitly proposed for skin damage from multiple particles. However, the following points serve as guidelines for establishing such a criterion:

1. As in the case of single-particle sources, damage to the skin will occur when the survival level of the germinative cells is reduced to less than 0.001 over an area sufficiently large to preclude replacement of dead cells via proliferation.¹⁰
2. Such a reduction in survival occurs at a lower dose level from a multiparticle source than from a single-particle source. Krebs estimates that a uniform 1300-rad dose from a multiparticle source would cause the same reduction in survival level brought about by a 1500-rad dose from a single-particle source.¹³

3. In view of the difference between the predicted single-particle critical dose (1500 rads) and the corresponding experimentally determined value of 660 rads, an adjustment has to be made to the suggested multiple-particle value to bring it into line with experiment.

4. It seems reasonable to accept a proportional dose for the multiparticle situation; i.e., $(1300/1500) \times 660 \approx 570$ rads. That is, exposure of the skin (100- μ depth) to a uniform deposited dose of 570 rads from a multiple source will be assumed sufficient to damage the skin in the manner described for the single-particle exposure.

RESULTS AND DISCUSSION

Doses from Single Particles

Point depth doses (estimated at 100- μ tissue depth directly below the fallout particle) and Krebs doses (estimated at a point radially displaced 4000 μ in a plane 100 μ below the skin surface) were computed for particles 50, 100, 200, 500, 750, and 1000 μ in diameter; for each particle size, doses were computed for 10^3 , 10^4 , 10^5 , and 10^6 sec of delay time (time between weapon detonation and deposition of the particle on the skin). The fallout particles were assumed to contain 10^{15} fissions per cubic centimeter. For all but exceptional situations, 10^{15} fissions/cc is considered the maximum expected fallout activity. Beta doses from fallout of higher fission density can be obtained from the values reported here by linear extrapolation.

Figures 7 to 10 present samples of the computer-plotted doses as functions of particle retention time on the skin. It can be seen from Fig. 7, which presents Krebs doses for the earliest particle arrival time considered, that single fallout particles smaller than 500 μ in diameter, landing on the skin as early as 10^3 sec (16.7 min) after detonation, will not cause any skin burns. A single 500- μ particle arriving even this early has to be retained about 10 hr before it delivers the 660 rads required for damage. Table 1 shows experimental data obtained at Oak Ridge National Laboratory (ORNL) for expected retention times of particles on human skin under normal conditions of temperature and humidity.¹⁴ Considering the values in Table 1, even a 500- μ particle would obviously be incapable of producing a 1-mm lesion.

Figure 8 presents the point depth doses delivered by the same particles under the same (early arrival) conditions. Comparison of Figs. 7 and 8 shows that point depth doses are higher than the corresponding Krebs doses by a factor of 10^2 to 10^3 depending on the particle size. Lower ratios correspond to larger particle sizes.

From Figs. 9 and 10, it can be seen that, after a delay of a little over 10^4 sec (about 2.8 hr), even a 1000- μ particle can be tolerated, provided its retention time does not exceed its expected value in Table 1.

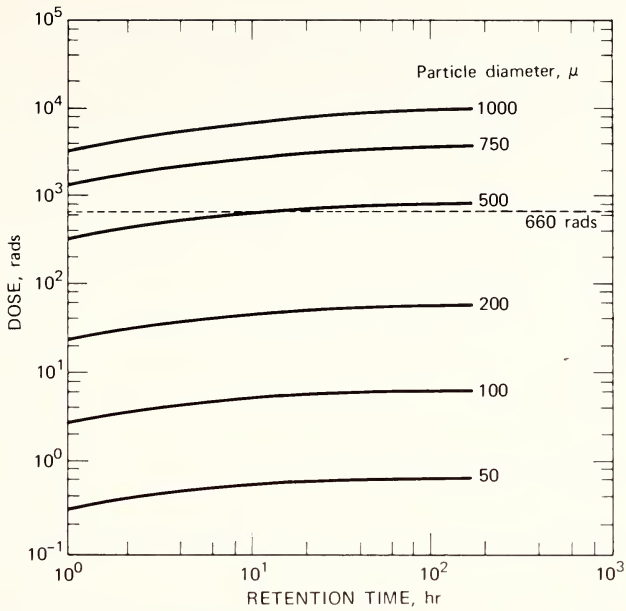

Fig. 7 Krebs dose delivered to the skin by single fallout particles at an exposure starting time of 10^3 sec after detonation. Tissue depth, 100 μ .

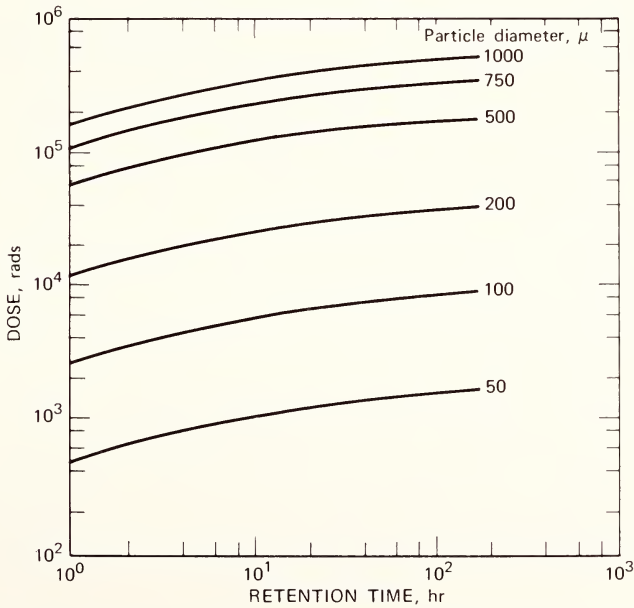

Fig. 8 Point depth dose delivered to the skin by single fallout particles at an exposure starting time of 10^3 sec after detonation. Tissue depth, 100 μ .

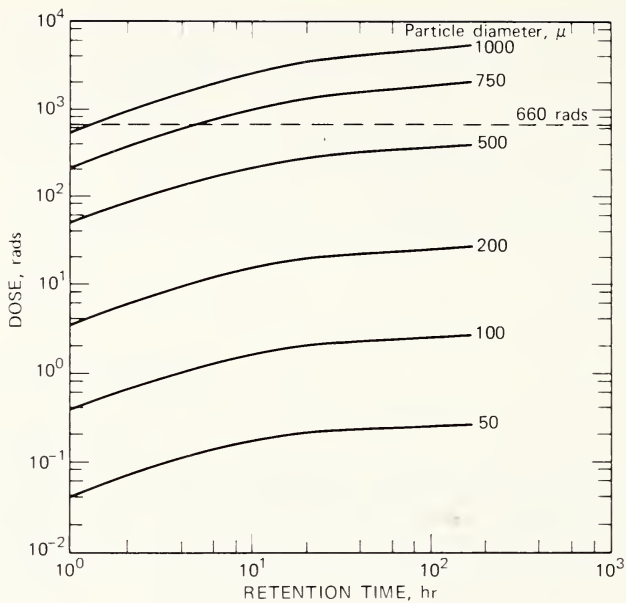

Fig. 9 Krebs dose delivered to the skin by single fallout particles at an exposure starting time of 10^4 sec after detonation. Tissue depth, 100 μ .

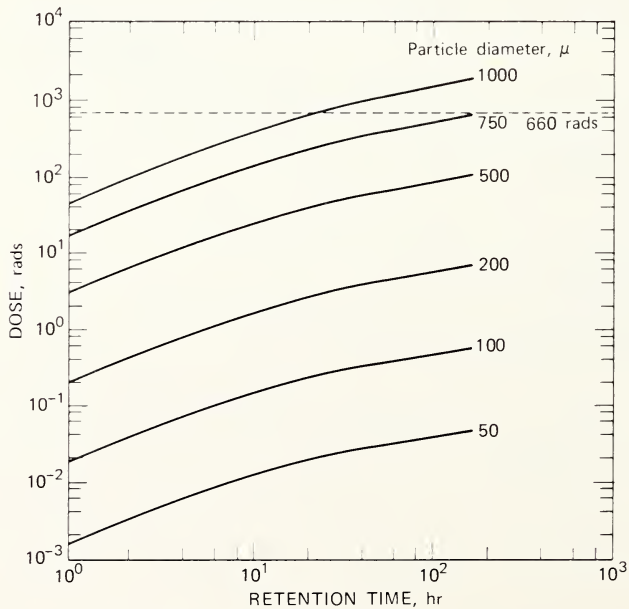

Fig. 10 Krebs dose delivered to the skin by single fallout particles at an exposure starting time of 10^5 sec after detonation. Tissue depth, 100 μ .

Table 1
 EXPECTED RETENTION TIMES OF
 PARTICLES ON HUMAN SKIN*

Particle diameter, μ	Time, hr
50	6.8
100	3.5
200	2.7
500	2.2
750	2.1
1000	2.0

*From Ref. 14.

Figure 10 shows further that, after a delay of 10^5 sec (about 28 hr), no single particle of any size can possibly cause a beta burn (except for the 1000- μ particle retained for an inordinately long time).

Doses from Multiparticle Fallout

Samples of the data computed with the Multiparticle Model are shown in Figs. 11 to 15. In these figures time-integrated doses from fallout deposition densities of 100, 200, 500, 1000, 2000, and 5000 mg/sq ft for different particle-size distributions have been plotted as functions of fallout retention time. All computations are based on 10^{15} fissions/cc. Delay times of 10^3 , 10^4 , 10^5 , and 10^6 sec are covered.

Figure 11 shows that for a delay time of 10^3 sec even the lowest deposition density (100 mg/sq ft) of particles of 100- μ mean diameter and 1000- μ maximum diameter (size distribution A) can deliver to the skin in less than 1 hr more than the 570 rads required for damage in the multiparticle situation. However, as seen in Fig. 12, the same mass of fallout of 1000- μ mean diameter and 2000- μ maximum diameter (size distribution B) delivers a maximum of only 300 rads, even if retained over 100 hr. Other size distributions give intermediate doses.

The situation changes somewhat at the next higher fallout-arrival (delay) time, 10^4 sec. A 200 mg/sq ft deposit of size distribution A can be tolerated in this case for about 1.5 hr (Fig. 13).

After a delay of 10^5 sec, a 2000 mg/sq ft deposit of size distribution A gives the critical 570 rads in about 1.5 hr (Fig. 14); after a delay of 10^6 sec (11.5 days), it takes 5000 mg/sq ft of the same size distribution about 10 hr to cause skin burns (Fig. 15).

Other formulations of output data can be derived from the multiparticle dose computations. A few examples follow.

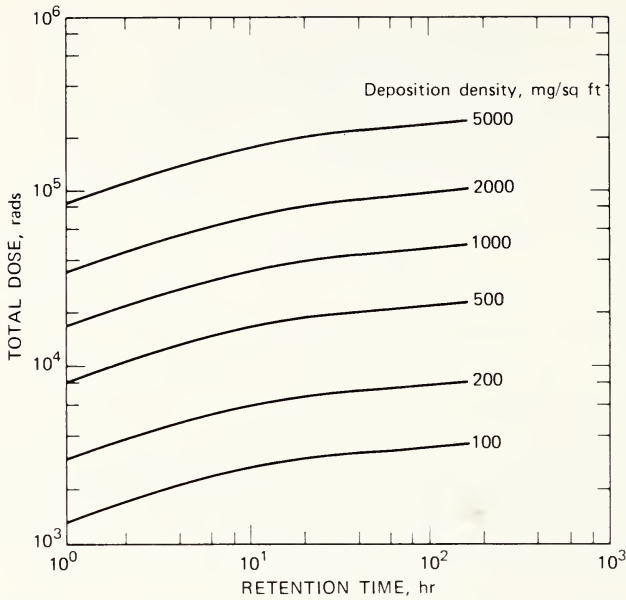

Fig. 11 Dose delivered to the skin by multiparticulate fallout of 100- μ mean diameter and 1000- μ maximum diameter at an exposure starting time of 10^3 sec after detonation. Tissue depth, 100 μ .

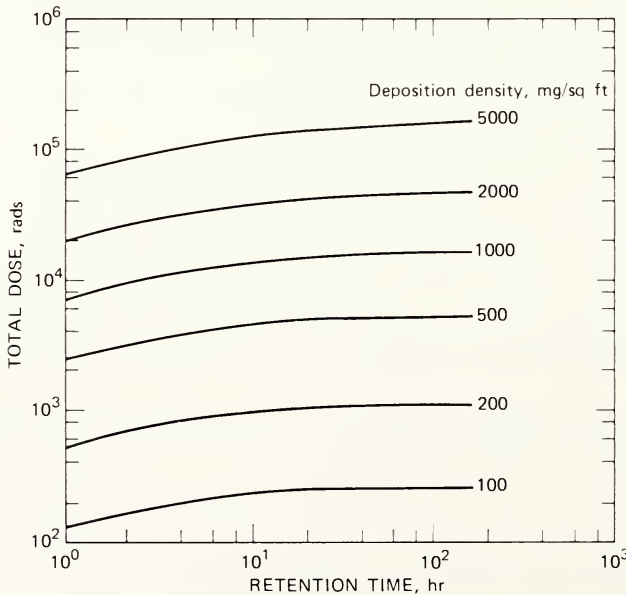

Fig. 12 Dose delivered to the skin by multiparticulate fallout of 1000- μ mean diameter and 2000- μ maximum diameter at an exposure starting time of 10^3 sec after detonation. Tissue depth, 100 μ .

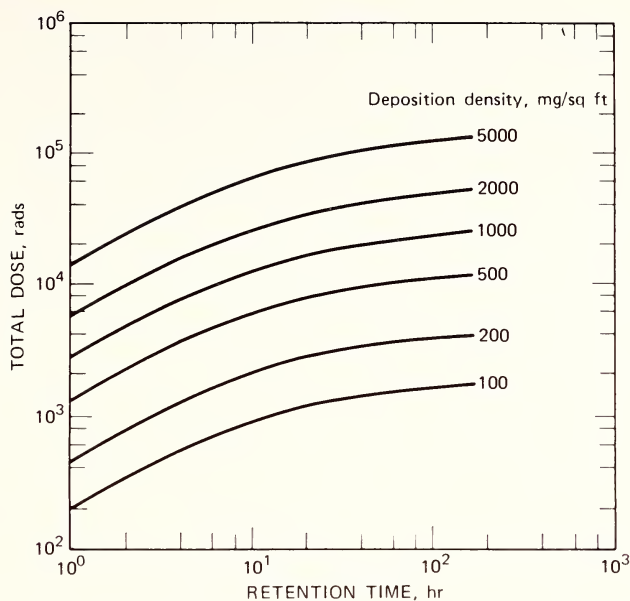

Fig. 13 Dose delivered to the skin by multiparticle fallout of 100- μ mean diameter and 1000- μ maximum diameter at an exposure starting time of 10⁴ sec after detonation. Tissue depth, 100 μ .

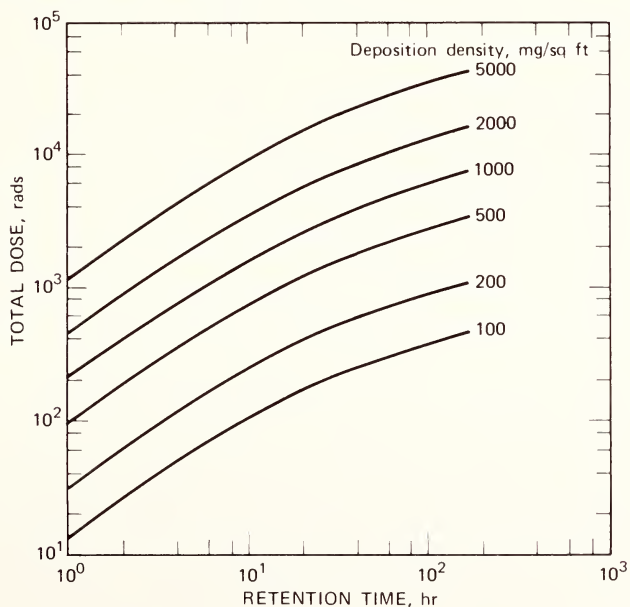

Fig. 14 Dose delivered to the skin by multiparticle fallout of 100- μ mean diameter and 1000- μ maximum diameter at an exposure starting time of 10⁵ sec after detonation. Tissue depth, 100 μ .

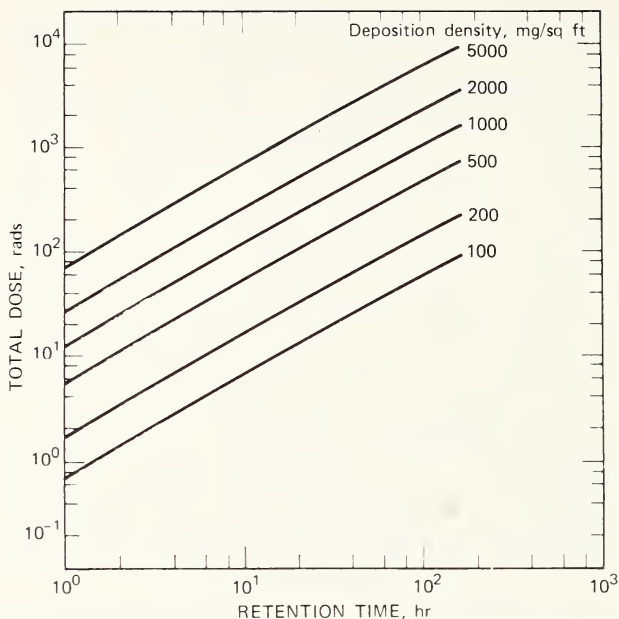

Fig. 15 Doses delivered to the skin by multiparticle fallout of 100- μ mean diameter and 1000- μ maximum diameter at an exposure starting time of 10^6 sec after detonation. Tissue depth, 100 μ .

Table 2 presents one formulation, the effect of exposure-initiation time (delay time) on the Krebs dose received by the skin from the same fallout deposition density. The table presents doses delivered by two deposition densities, 100 and 2000 mg/sq ft, in each case over 1-, 2-, 5-, 10-, and 24-hr exposure periods, all following delays of 24, 48, 72, and 168 hr. Also given are the time periods for which fallout under these conditions would have to be retained before delivery of 570 rads takes place if the exposure starts at 24, 48, 72, and 168 hr postdetonation. In both parts of the table, size distribution A is assumed.

Another type of output formulation that may be useful (not illustrated) would show the skin dose accumulated in 1 hr, e.g., starting at fallout arrival or some later time, as a function of distance from ground zero for various weapon yields. The figure could be obtained by combining the dose data given here with the data of Clark and Cobbin,¹⁵ for example; the latter data relate midrange particle size to downwind distance from ground zero for different weapon yields. It must be recognized that, for a given weapon yield and downwind distance, fallout phenomenology, as exemplified by the Clark-Cobbin approach, specifies uniquely not only (1) the midrange particle size but also (2) the ground-surface deposition density and (3) the times of fallout arrival and

Table 2
EFFECT OF EXPOSURE-INITIATION TIME ON KREBS
DOSES DELIVERED TO THE SKIN*

Retention time, hr	Exposure-initiation time			
	24 hr	48 hr	72 hr	168 hr
Fallout Deposition Density of 100 mg/sq ft†				
<i>Doses received, rads:</i>				
1	18	8	5	2
2	36	16	10	4
5	84	39	24	9
10	151	73	46	17
24	291	153	101	41
<i>Retention times required to accumulate 570 rads, hr:</i>				
	76	250	600	2400
Fallout Deposition Density of 2000 mg/sq ft‡				
<i>Doses received, rads:</i>				
1	466	217	120	50
2	912	423	230	98
5	2138	998	608	228
10	3862	1879	1182	445
24	7420	3918	2571	1030
<i>Retention times required to accumulate 570 rads:</i>				
	78 min	170 min	4 hr, 40 min	13 hr, 20 min

*Mean particle diameter of 100 μ and maximum particle diameter of 1000 μ .

† 4×10^{13} fissions/sq ft.

‡ 8×10^{14} fissions/sq ft.

cessation. The unique values of the deposition density and times of arrival and cessation would have to be considered in the preparation of a family of curves covering a range of weapon yields. Skin deposition density could be parameterized at, for example, 100 mg/sq ft, which would allow for consideration of fallout-particle resuspension, or simply for normalization to the correct skin-deposition value at each point. A carefully planned family of curves could thus provide a picture of those yields and downwind distances at which a 1-hr

exposure to fallout which starts to deposit on the skin at arrival time or later would produce the critical skin dose of 570 rads. Such kinds of results could be most useful in postattack planning.

REFERENCES

1. R. Loevinger, E. M. Japha, and G. C. Brownell, Discrete Radioisotope Sources, in *Radiation Dosimetry*, pp. 693-754. Academic Press, Inc., New York, 1956.
2. J. C. Ulberg and D. B. Kochendorfer, Models for Estimating Beta Dose to Tissue from Particle Debris in Aerospace Nuclear Applications, USAEC Report USNRDL-TR-1107, Naval Radiological Defense Laboratory, Dec. 12, 1966.
3. O. H. Hogan, P. E. Zigman, and J. L. Mackin, Beta Spectra II. Spectra of Individual Negatron Emitters, Naval Radiological Defense Laboratory, USAEC Report USNRDL-TR-802, Dec. 16, 1964.
4. C. F. Miller, Fallout and Radiological Countermeasures. Volume I, Report AD-410522, Stanford Research Institute (Project No. IM-4021), 1963.
5. R. F. Korts and J. H. Norman, A Calculational Model for Condensed State Diffusion Controlled Fission Product Absorption During Fallout Formation, Report GA-7598, General Dynamics Corp., General Atomic Div., Jan. 10, 1967.
6. L. V. Spencer, Energy Dissipation by Fast Electrons, National Bureau of Standards, Monograph 1, 1959.
7. G. B. Curtis and J. S. Petty, A Program to Compute Beta Radiation Dosage. Volume I. Program Description. Final Report, USAEC Report TID-24033 (Vol. 1), American Research Corp., Aug. 1, 1967.
8. S. Z. Mikhail, Tissue Beta Radiation Doses from Particulate Fission-Product Sources: Comparison of Model Predictions with Experimental and Monte Carlo Values, Report ESA-TR-70-01, Environmental Science Associates, 1970.
9. R. Loevinger, Extrapolation Chamber for the Measurement of Beta Sources, *Rev. Sci. Instr.*, **24**: 907 (1953).
10. J. S. Krebs, The Response of Mammalian Skin to Irradiation with Particles of Reactor Debris, Report USNRDL-TR-67-118, Naval Radiological Defense Laboratory, 1967.
11. P. D. Forbes and S. Z. Mikhail, Acute Lesions in Skin Produced by Radioactive Microspheres, Temple University Report, Contract SNPN-49, 1970.
12. S. L. Brown, Disintegration Rate Multipliers in Beta-Emitter Dose Calculations, USAEC file No. NP-15714, Stanford Research Institute (SRI Project MU-5116), August 1965.
13. J. S. Krebs, Stanford Research Institute, personal communication, September 1970.
14. B. R. Fish, Environmental Studies: Radiological Significance of Nuclear Rocket Debris. Semiannual Progress Report July 1-Dec. 31, 1964, USAEC Report ORNL-TM-1053, Oak Ridge National Laboratory, April 1965. (Classified)
15. D. E. Clark, Jr., and W. C. Cobbin, Some Relationships Among Particle Size, Mass Level and Radiation Intensity of Fallout from a Land-Surface Nuclear Detonation, Report USNRDL-TR-639, Naval Radiological Defense Laboratory, Mar. 21, 1963.

MEASUREMENT AND COMPUTATIONAL TECHNIQUES IN BETA DOSIMETRY

JAMES MACKIN, STEPHEN BROWN, and WILLIAM LANE
Stanford Research Institute, Menlo Park, California

ABSTRACT

A small beta dosimeter developed for use in biological-effects experiments was calibrated and tested in a series of laboratory experiments, including a uniform-volume-source exposure, a point-source exposure, surface-roughness exposures, and an environmental resistance test. The dosimeters were then used in cooperation with biological experiments being conducted by other investigators. These included a plant-community exposure, a corn-plot exposure, three wheat and potato exposures, and a field test of surface roughness. The measured data were then compared with calculated values, and, in general, agreement was found to be satisfactory.

The beta-ray component of fallout radiation is important to many biological and ecological effects of nuclear war. For some small organisms, including most food and feed-crop plants, it is surely the dominant component, at least in the early stages of growth. Recognizing the importance of estimating biological damage from beta radiation, Stanford Research Institute (SRI) conducted a series of theoretical and experimental studies in an attempt to make such estimates with accuracies sufficient for damage-assessment studies.¹⁻⁵

When young bean plants were exposed to ^{90}Y radiation,² both contact-source and beta-bath geometries produced plant sterility at estimated doses of 100,000 rads to leaves and 2000 rads to meristems. Although these few results only indicated a range of expected results, they verified the need for additional studies of beta-dose computation and measurement.

The theoretical basis for the interpretation of beta dose was investigated by comparing the results of computational models^{3,4} with experimental measurements made with lithium fluoride powder exposed to a variety of ^{90}Y sources.⁵ In the simplest geometries the comparison was quite good, but the computational procedures were not sufficiently developed to deal accurately with some

of the more complicated cases. In a damage-assessment context, however, the discrepancies were not large enough to make damage estimates grossly uncertain. In such a context, then, the agreement for the relatively simple geometries was adequate. Real fallout exposures are not even relatively simple, however; they deal with very complex geometries that would require an inordinate effort to model mathematically. Methods must be sought that can estimate beta damage with much less effort.

APPROACH

The specific objective of our investigation⁶ was to develop better dosimetric methods for use in biological-effects experiments and thus to provide a means for relating observed effects to existing and revised computational methods. To this end, a small beta dosimeter was developed and tested in the laboratory and then was used to measure beta doses in field experiments conducted by cooperating investigators.

Preparation of Sources

In all cases the basic starting material for the preparation of each radiation source was an essentially carrier-free solution of ⁹⁰Y activity. Aliquots were taken from each solution to prepare sources in the form of (1) activity uniformly dispersed in gelatin, (2) evaporated aliquots of solution, and (3) synthetic fallout. The gelatin sources were prepared simply by adding measured amounts of active solution to stirred suspensions of gelatin in distilled water and pouring the gelatin into suitable molds for hardening.

Sources prepared from liquid aliquots were made by stretching Mylar film over a given substrate, usually a clear plastic. A small aliquot was handpipetted onto the film and then air dried. The sources were stripped from the substrate after exposures were completed and were measured directly in the ionization chamber.

The basic material employed for the preparation of solid sources was synthetic fallout of particles in the sieve size range of 88 to 177 μ . The fallout simulant was prepared by spraying an aliquot of radionuclide solution on a sized portion of warm sand, heating it slowly to dryness, and then thermally treating it at high temperature so that the activity is fixed on the particle surfaces. Solid sources for surface-roughness experiments were prepared by dispersing the simulant in air and permitting the particles to fall under gravity. A cylindrical pipe 3 ft long and 6 in. in diameter, positioned over the substrate, was used to direct the particles uniformly over a circular area.

In the field experiments the method of fallout-simulant dispersal was determined by the cooperating investigator. The University of North Carolina experiments used a shielded container from which the simulant was dispersed through a slit. The container was moved over the plots by hand. In the

University of California experiments, the method of dispersal utilized a motorized hopper that reciprocated across the plot while being moved down the plot on railings. Dispersal was accomplished by a rotary rod that fed simulant into a long slot as in a lawn seeder.

Radiation Dosimetry

A principal objective of the research was to develop a dosimetric method that was more convenient than the loose-powder method used in the previous work. The loose-powder method used thermoluminescent lithium fluoride (LiF) powder, which has a wide range of dose sensitivities (from a few millirads to kilorads), low energy dependence, reproducibility, and stability. A disadvantage of the loose-powder method is that much care must be exercised both in emplacement and in subsequent recovery of the material.

To surmount this difficulty, we mounted a joint effort with Radiation Detection Co. to design a convenient dosimeter with the features mentioned previously. The dosimetric material was again LiF powder,* in the size range 80 to 200 mesh, which was obtained in quantity and standardized with ^{60}Co . Calibration of each dosimeter independently was unnecessary. This simplified the experimental procedures since the dosimeters were completely interchangeable. Calibration was based on exposure of aliquots of powder to ^{60}Co and on the factor 0.807 rad/R. The factor was based on 0.869 rad deposited in air per roentgen and 0.929 for the ratio of stopping powers for ^{60}Co gammas for LiF and air.

The LiF powder was encapsulated in glass capillary tubing approximately 2 mm in outside diameter and about 0.1 mm (31.8 mg/cm^2) thick and was sealed by flaming. The dosimeters, which averaged about 5 mm long and contained either 6 or 12 mg of LiF powder each, were individually tested for environmental closure by being allowed to stand under 30 cm of water for 15 min or longer. When returned to Radiation Detection Co. for readout, they were placed in a special planchet, and the luminescence was measured directly through the glass in a Mark IV model 1100 TLD Reader.

Method of Comparison

Theory and experiment were compared in terms of the disintegration-rate multiplier (DRM). The DRM for experimental results is obtained by dividing the observed dose by the total number of disintegrations during the period of exposure:

$$\text{DRM} = \frac{D}{B_0} \left(\frac{1 - e^{-\lambda t}}{\lambda} \right) \quad (1)$$

*The powder used was Radiation Detection Co. "Throwaway" Powder, Batch 8/69, having linear response to gamma radiation through 10,000 rads.

where D = dose, rads

B_0 = initial source strength, dis/sec/unit area, volume, or mass, as appropriate

λ = decay constant for ^{90}Y (3.0×10^{-6} /sec)

t = exposure time, sec

Infinite-medium methods, line-of-flight perturbation methods, or pseudo-source methods were used in the computation of beta dose. These models are described in another report⁵ and will not be discussed here. In judging the adequacy of the comparisons, we developed the rule of thumb that agreement with a factor of 2, on the average, was acceptable. This degree of uncertainty has been shown to result in less than 10% uncertainty in damage-assessment results.

Results of Experiments

Several laboratory experiments were conducted to test the dosimeter. First, dosimeters were calibrated by exposure to an effectively infinite uniform-volume source. Next, verification of their performance was obtained with exposures at various distances from a point source. The geometrical backscattering effect previously reported was again observed. A series of exposures using a fallout-simulant source distributed on sized pebble substrates was then performed. The general features of the measured surface-roughness attenuation factor were similar to those found before, but the variation in the factor with substrate particle size was less pronounced than previously, probably because of differences in handling between dispersal and exposure.

Several sets of field-exposure measurements were also conducted. Two plant communities were contaminated with fallout simulant by investigators from the University of North Carolina, and dose measurements were made with SRI dosimeters. The comparison of measured and calculated doses was satisfactory within the uncertainties of the exposure geometry. Next, a plot of corn plants was contaminated with fallout simulant by investigators from the University of California, Berkeley, and again dosimeters were distributed on and near the plants. Agreement was not so good as previously, because of difficulties in dispersing the simulant and recovering the dosimeters, but order-of-magnitude agreement was obtained. In a second University of California series plots containing wheat and potato plants were contaminated. Agreement between measured and calculated values was again found to be good, except where the computational model was clearly inappropriate. The final set of dose measurements, taken over a smooth plot of contaminated loam, yielded a surface-roughness factor of about 0.75.

Reasonable agreement between calculated and observed beta doses can therefore be obtained when sufficiently good input information can be provided for the computations. More effort is indicated to obtain better input values for such parameters as plant density and fraction of fallout retained on foliage.

Attention should also be given to empirical dose-prediction methods that do not depend so heavily on precise input information.

REFERENCES

1. S. L. Brown, Disintegration Rate Multipliers in Beta-Emitter Dose Calculations, USAEC file No. NP-15714, Stanford Research Institute (SRI Project No. MU-5116), August 1965.
2. W. B. Lane and J. L. Mackin, Response of Bean Plants to Beta Dose Problems, Report TRC-68-16, Stanford Research Institute, November 1967.
3. S. L. Brown and O. S. Yu, Computational Techniques in Beta Dose Problems, Report TRC-68-13, Stanford Research Institute, January 1968.
4. S. L. Brown, Beta Radiation Effects on Agriculture, Report TN-RMR-34, Stanford Research Institute, June 1968.
5. J. L. Mackin, S. L. Brown, and W. B. Lane, Beta Radiation Dosimetry for Fallout Exposure Estimates: Comparison of Theory and Experiment, Report TRC-69-26, Stanford Research Institute, June 1969.
6. S. L. Brown, W. B. Lane, and J. L. Mackin, Beta Radiation Hazard Evaluation, Stanford Research Institute, (in press).

MEASUREMENT OF BETA DOSE TO VEGETATION FROM CLOSE-IN FALLOUT

A. D. KANTZ

EG&G, Inc., Santa Barbara Division, Goleta, California

ABSTRACT

Dosimetry experiments are described in which both beta and gamma-ray doses to the environment and to vegetation were measured with thermoluminescent dosimetric techniques in the close-in fallout fields from the Plowshare cratering events Cabriole and Schooner. The beta doses measured were found to be an order of magnitude greater than the gamma-ray doses at the same locations. This work was performed in support of ecological- and environmental-effects studies sponsored by the Environmental Sciences Branch of the Atomic Energy Commission's Division of Biology and Medicine.

Before the Plowshare Palanquin event in April 1965, radiation damage to vegetation from nuclear detonations, whether aboveground or belowground, was attributed largely to heat, blast, and thermal shock.¹⁻⁹ After the Palanquin detonation, however, extensive damage to vegetation was observed over an area of about 4 km² in which there was no evidence of blast, shock, or thermal damage except in the immediate vicinity of the crater.¹⁰

Since an experimental study of the gamma-ray doses required to kill the various types of vegetation prevalent at the Palanquin site revealed that the amount of radiation encountered on the peripheries of the damage patterns was insufficient to account for the observed damage, it was hypothesized that beta radiation was a contributing factor. To validate this view, we developed special dosimetry techniques for measuring the gamma-ray and beta dose in the fallout fields of subsequent Plowshare cratering events. The objectives were to:

1. Determine the total dose to plants and distinguish clearly between gamma-ray and electron contributions.
2. Evaluate any low-energy photon contribution.
3. Specify as much information as possible regarding the energy and distribution of the beta sources.

This paper describes the dosimetry techniques and their application to radiation-dose measurements in support of ecological- and environmental-effects studies sponsored by the Environmental Sciences Branch of the Atomic Energy Commission's Division of Biology and Medicine during the Cabriole and Schooner cratering events at the Nevada Test Site in 1968. The assessment of vegetation damage is described in studies by Rhoads et al.^{1,12}

DOSIMETRY TECHNIQUES

The general characteristics of fallout radiation expected from a cratering event include a 1-MeV gamma-ray component, an associated beta component with energies in the 1-MeV region, and a possible low-energy-photon characteristic. Two approaches for measuring this mixed field are equally valid: (1) measurement of fluence and interpretation of dose deposition or (2) direct measurement of absorbed dose in some material and correlation with another material through known absorption coefficients.

Because of time constraints and the need for obtaining the best information possible on the beta source, we chose the more straightforward of the two methods, that of measuring fluence by determination of depth-dose profiles, for the Cabriole and Schooner events.

Dosimeter Design

The dosimeters for these experiments had to be designed to accommodate very wide dose ranges and to be capable of withstanding weathering under severe winter conditions at an elevation of 6000 ft for a period of several weeks. Also, because of the large number of dosimeters required, logistical considerations made it desirable for the dosimeters to be easy to fabricate, field, and analyze. Calcium fluoride (CaF_2) appeared to fulfill these requirements, and thermoluminescent dosimeters (TLD's) made up of hot-pressed chips of CaF_2 -Mn measuring 3 by 3 by 1.5 mm were constructed.

The dosimeters, which were designed to simulate energy deposition from ionizing radiation in plant tissue, consisted of a 32-mm-square piece of 3-mm-thick plastic polycarbonate containing eight holes, each 7 mm in diameter (see Fig. 1). The CaF_2 -Mn chips, with individual shields, were placed in the holes, and the entire dosimeter was covered by a thin, light-tight film. The shielding for the chips during the Cabriole event was as follows: (1) none except the thin, light-tight covering, (2) 0.17-mm Mylar, (3) 0.55-mm polycarbonate, (4) 1.55-mm polycarbonate, (5) 0.85-mm aluminum, and (6) 0.5-mm lead.

Since the thickness of the TLD chips was sufficient to completely stop electrons with energies up to 1.0 MeV, readings on individual chips were proportional to energy fluence incident on the chip. The change in fluence (ergs per square centimeter) as mass was added in front of the TLD was used to infer the dose (ergs per gram).

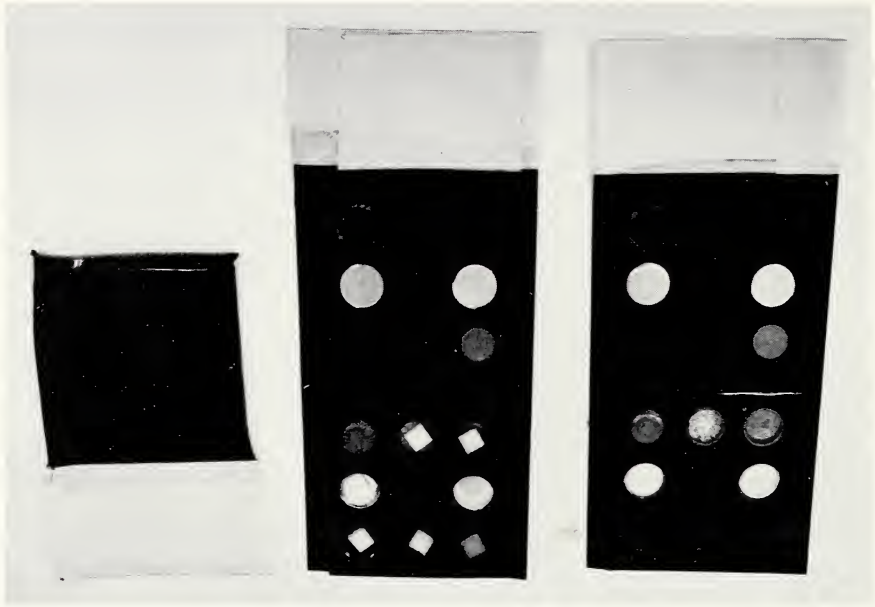

Fig. 1 Thermoluminescent dosimeters (TLD's) constructed for the Cabriole event. Shown from left to right are the open TLD holders, the holders with chips in place, and the dosimeters ready for use in the field.

Shielding was selected to produce a gradual decrease in beta contribution, the thickest shield being capable of stopping the most energetic beta particles. This thickness, however, did not require significant correction for the absorption of 1-MeV gamma rays. The presence of a low-energy-photon component could be inferred by differences in the stopping power of polycarbonate and aluminum. These materials present equal absorption of electrons but have a Z dependence for absorption of low-energy photons. Thus a high reading for the polycarbonate-shielded chips signified a low-energy-photon component whose magnitude could be estimated.

Field Arrangement

For the Cabriole event the dosimetry stations were positioned along two arcs (Fig. 2). This arrangement was based on records of the early dose rates for the preceding Palanquin event and on the availability of materials and personnel. The first arc was along a radius 610 m (2000 ft) from ground zero (GZ), extending from 330° on the west to 90° on the east. The second arc, which was along a radius 915 m (3000 ft) from GZ, was much shorter than the first and covered the direction from GZ considered most likely to be contaminated on the basis of weather conditions anticipated at the time of the event.

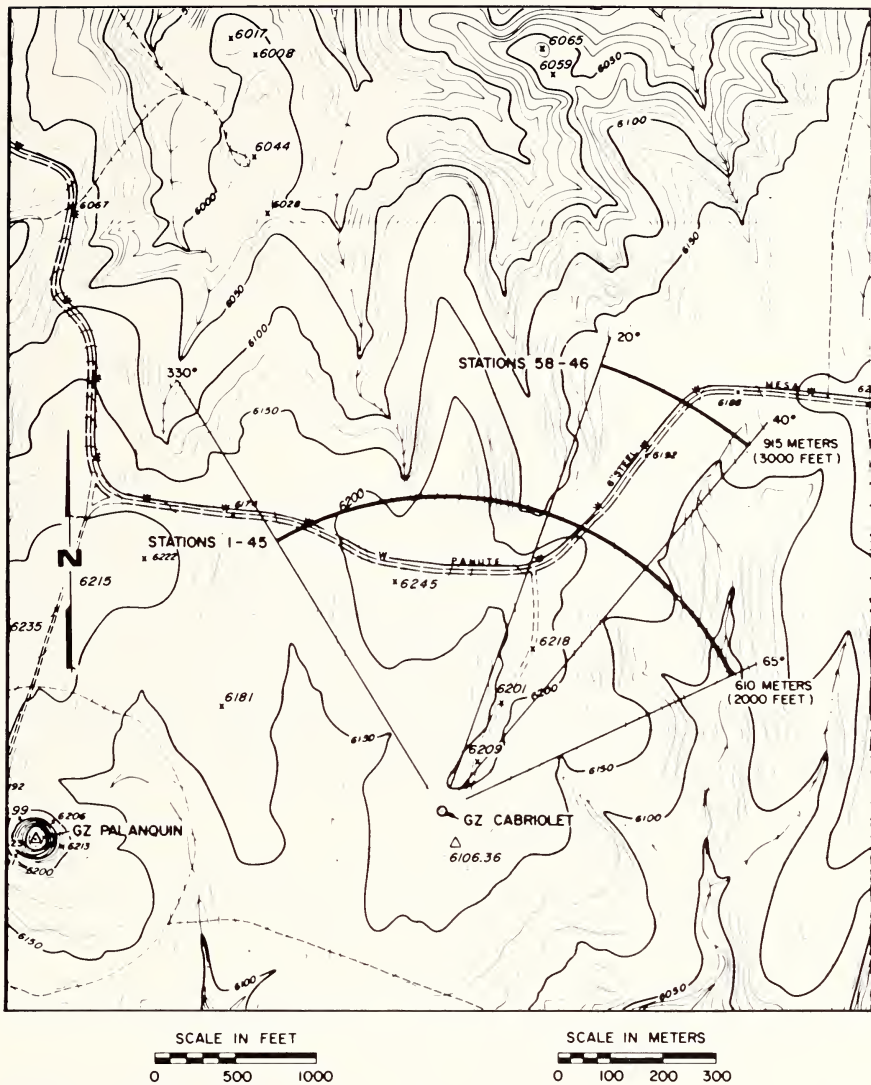

Fig. 2 Map of the Cabriolet area, showing locations of arcs along which dosimetry stations were positioned.

At each station along the arcs, the dosimeters were suspended from a vertical wire and were arranged in an array so that each dosimeter lay in a horizontal plane. The dosimeters were spaced above the soil surface at various distances to take advantage of the beta shielding represented by the air path from the ground to the dosimeter. The highest dosimeter was 150 cm above the soil surface; this was expected to be sufficient to raise it out of the beta bath.

Plant Correlation

Additional smaller dosimeters with only three chips were prepared and placed directly on shrubs in the vicinity of the vertical arrays. It was expected that the readings from the dosimeter 25 cm above the soil surface in the vertical array would closely resemble the average absorbed dose in the surrounding shrubs. The smaller dosimeters were fabricated with the following shielding: (1) minimum shielding, afforded by the thin cover, (2) a thick cover of lead capable of completely stopping the electrons so that no beta dose could be received, and (3) an intermediate shielding representing the gamma-ray background and a fraction of the beta contribution.

The dosimeters were arranged carefully on the exterior of shrubs in the immediate vicinity of the vertical stations and were oriented so that one dosimeter was on the front of the shrub (toward GZ), one on the back, one on the top, and one at a third side.

To further delineate the radiation levels, we fabricated a plant phantom for use as a fallout collector for each vertical array. The phantom consisted of two wire-mesh cylinders, one placed inside the other, with opposite ends closed. The cylinders were covered with cheesecloth, which had previously proved to be an efficient collector of radioactive debris. The retentive capacity of the phantoms for fallout was expected to be similar to that of actual shrubs. Dosimeters were placed on the shrub phantoms to correlate with the vertical arrays. These dosimeters successfully measured the small differences in both gamma-ray background and beta dose in the various geometries described.

Dosimeter Readout and Analysis

The dosimeter packages from the field were individually read out in a standard EG&G model TL-3 reader. Since the chips were calibrated against a standard ^{60}Co source, the scale readings were a direct measure of the exposure in roentgens.

The energy deposited in a $\text{CaF}_2\text{-Mn}$ chip when it is exposed to a calibrating ^{60}Co source is

$$E_1 = 86R(\rho At) \text{ ergs} \quad (1)$$

where R = exposure in roentgens

ρ = density of the dosimeter

A = area of the dosimeter

t = thickness of the dosimeter

The light emitted when the dosimeter is read is proportional to the energy (E_1):

$$L_1 = cE_1 \quad (2)$$

When the dosimeter is exposed to low-energy beta radiation and subsequently read out, the energy deposited per unit area is

$$\phi = \frac{E_2}{A} = \frac{L_2}{cA} = \frac{L_2}{A} \frac{86R\rho At}{L_1} \text{ ergs/cm}^2 \quad (3)$$

If the readout instrument is adjusted to read in roentgens ($R = L_1$), the final calibrating formula is

$$\phi = 86\rho t \times L_2 \text{ ergs/cm}^2 \quad (4)$$

For a typical chip ρt is 0.550 g/cm^2 . The calibrating relation is then

$$\phi = 47.3L_2 \text{ ergs/cm}^2 \quad (5)$$

where L_2 is the scale reading on the dosimeter.

Dose may be inferred from the readings ϕ_1 and ϕ_2 on two dosimeters covered by absorbers having masses m_1 and m_2 :

$$D = \frac{\phi_1 - \phi_2}{m_1 - m_2} \quad (6)$$

In this case dose is determined for the absorbing material.

Data taken with the use of Mylar may be used to infer dose in water by multiplying by the stopping power for water and dividing by the stopping power for Mylar:

$$D_{\text{H}_2\text{O}} = D_{\text{Mylar}} \times \frac{(dE/dx)_{\text{H}_2\text{O}}}{(dE/dx)_{\text{Mylar}}} \quad (7)$$

RESULTS AND DISCUSSION

Project Cabriolet Dosimetry

The data from each array were plotted as a function of shield thickness. Station 7, near the center of the fallout pattern, shows the typical decrease in scale readings with increasing shield thickness (Fig. 3). The residual reading (from the lead-covered chip) was due to gamma-ray radiation. For every station the gamma-ray contribution was found to be the same for each vertical position, within a probable error of $\pm 3\%$.

The contribution of the gamma-ray dose was subtracted and the beta contribution evaluated from plots for each of the stations recovered. The penetration by the beta source through the shielding indicated an average range

of about 325 mg/cm^2 of Mylar. This corresponds to a beta source having a maximum energy of approximately 850 keV.

The maximum gamma-ray dose encountered on the Cabriole event in the center of the fallout pattern was approximately 700 rads (absorbed dose in water). Figure 4 shows the variation seen in the gamma-ray dose from the vertical array, from shrubs in the immediate vicinity of the stations, and on simulation shrub phantoms.

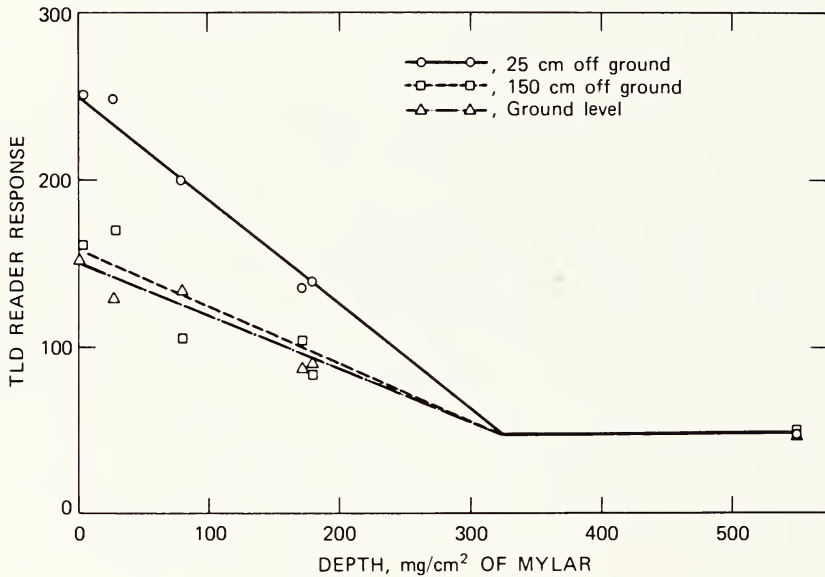

Fig. 3 Depth dose at Station 7 (Cabriole).

Figure 5 illustrates the gamma-ray radiation doses experienced by *Artemisia* shrubs in the vicinity of the stations and the variations in the doses received by the fronts, tops, and backs of the shrubs. It is evident from the illustrated data that the fronts received the greatest gamma-ray dose; the backs were protected to some extent. As anticipated, the variations in the doses were greatest in the center of the fallout pattern where erratic distribution could be expected.

The beta doses shown in Fig. 6 are derived for the dose that would be absorbed on the surface of vegetation located at that point. The pattern of the variations seen is somewhat different from the gamma-ray distribution. The beta doses tend to increase in the lower topographical regions where the gamma-ray contributions decreased. The protection of the backs of the shrubs is very marked in the center of the fallout pattern. The dependence is shown in Fig. 7. In regions outside the central pattern, the differences between front and back are negligible.

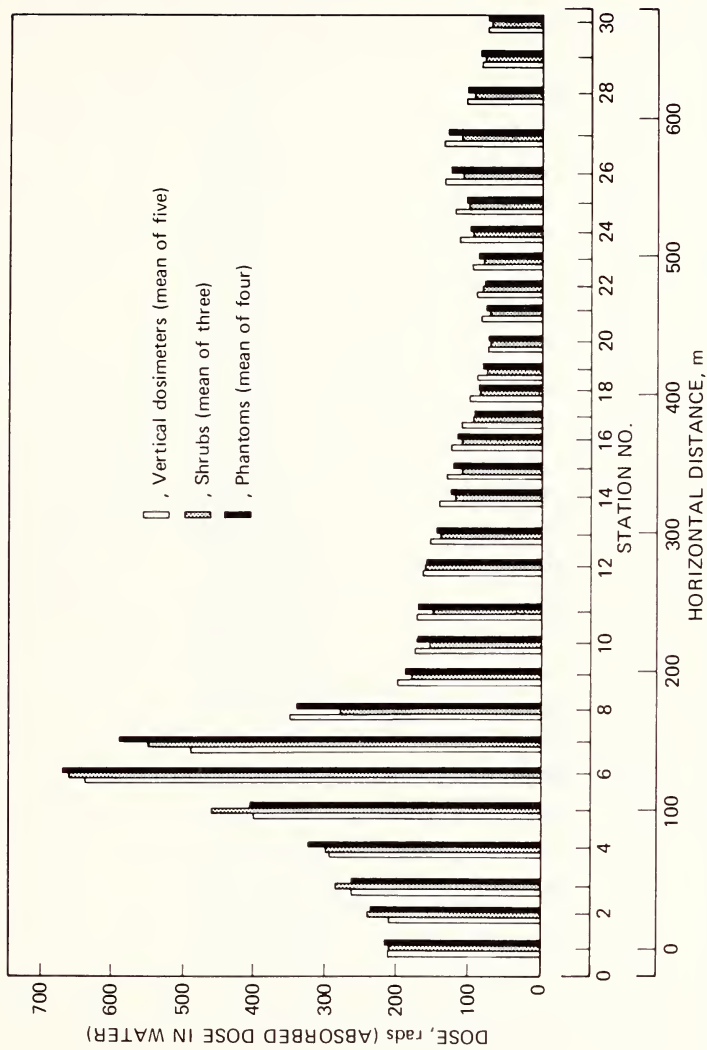

Fig. 4 Averaged gamma-ray doses at Stations 1 to 30, as measured by dosimeters on vertical strings, shrubs, and phantoms (Cabriolet).

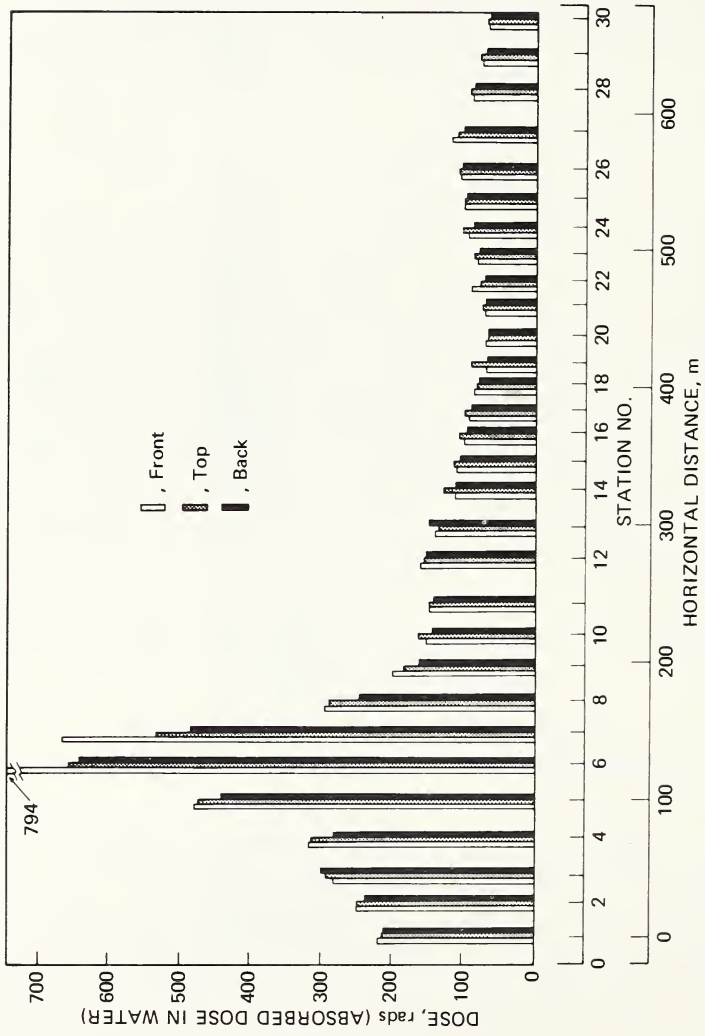

Fig. 5 Gamma-ray doses as measured at three positions on *Artemisia* shrubs (Cabriolet).

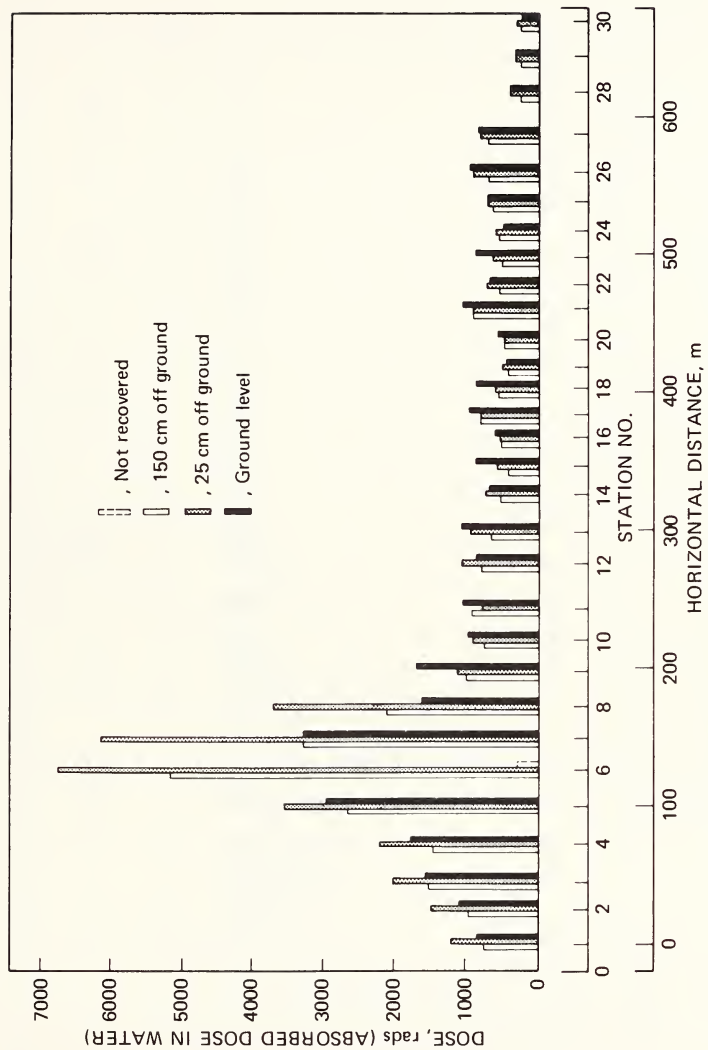

Fig. 6 Beta-radiation doses from incident beta fluxes (Cabriolet).

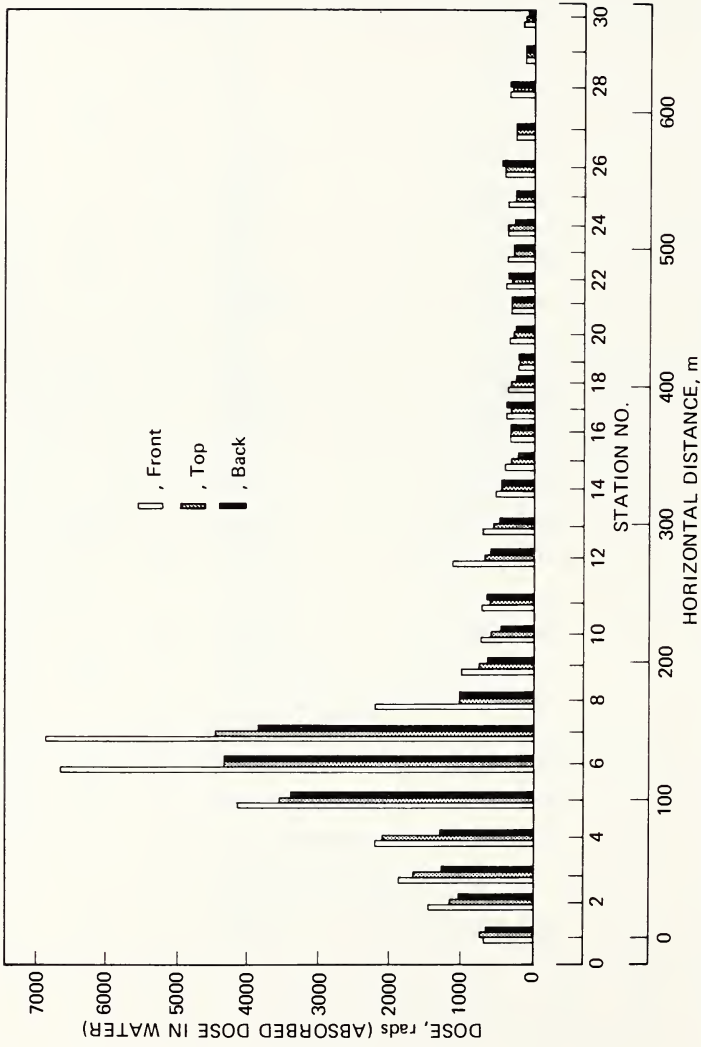

Fig. 7 Mean of beta doses as measured by dosimeters on fronts, tops, and backs of three *Artemisia* shrubs at each Station (Cabriolet).

Project Schooner

The area of ecological interest in the Schooner cratering event was a valley protected from the direct line of sight from GZ by canyon walls. The dosimetry instrumentation and techniques used to measure doses to the environment and vegetation were patterned closely after those used in the Cabriole event. However, certain modifications and additions were incorporated based on the Cabriole results.

The beta penetration to 325 mg/cm^2 of tissue during Cabriole indicated that dosimeters should be placed 3 to 4 m aboveground to escape the beta bath. Therefore during the Schooner event dosimeters were positioned at distances of 25, 100, and 300 cm above the soil surface in vertical arrays. Figure 8 shows the results of measurements at Station 0 near the edge of the central fallout pattern. The depth-dose profile obtained was very similar to that measured at Cabriole, and the beta penetration was identical.

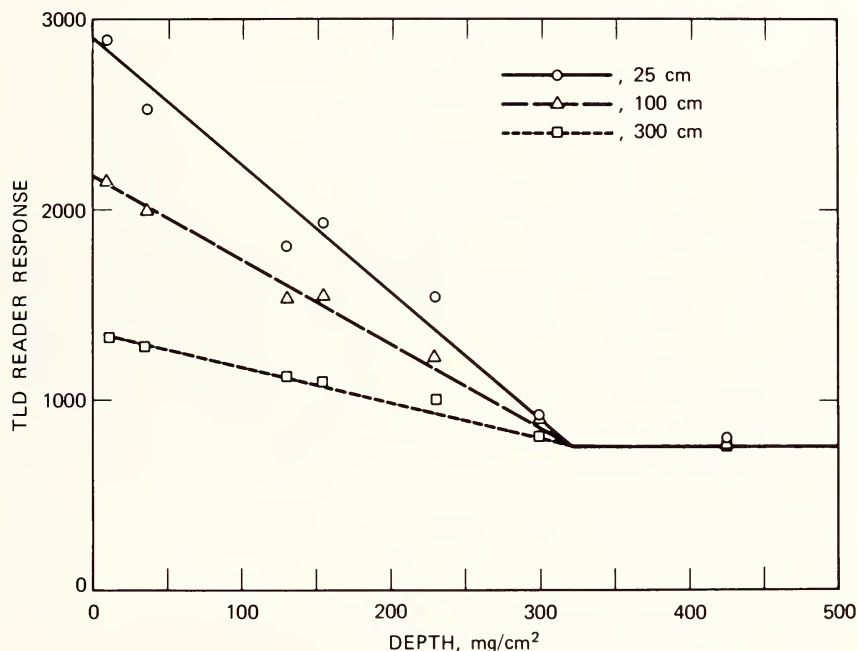

Fig. 8 Depth dose at Station 0 (Schooner).

For the Schooner event two of the eight $\text{CaF}_2\text{-Mn}$ chips in the dosimeters were provided with shielding only on the upper side or only on the lower side. Thus a beta source exclusively limited to the ground could be expected to contribute to the dose measured on one of the chips and a source from the sky to contribute exclusively to the other. The results of this directional lead

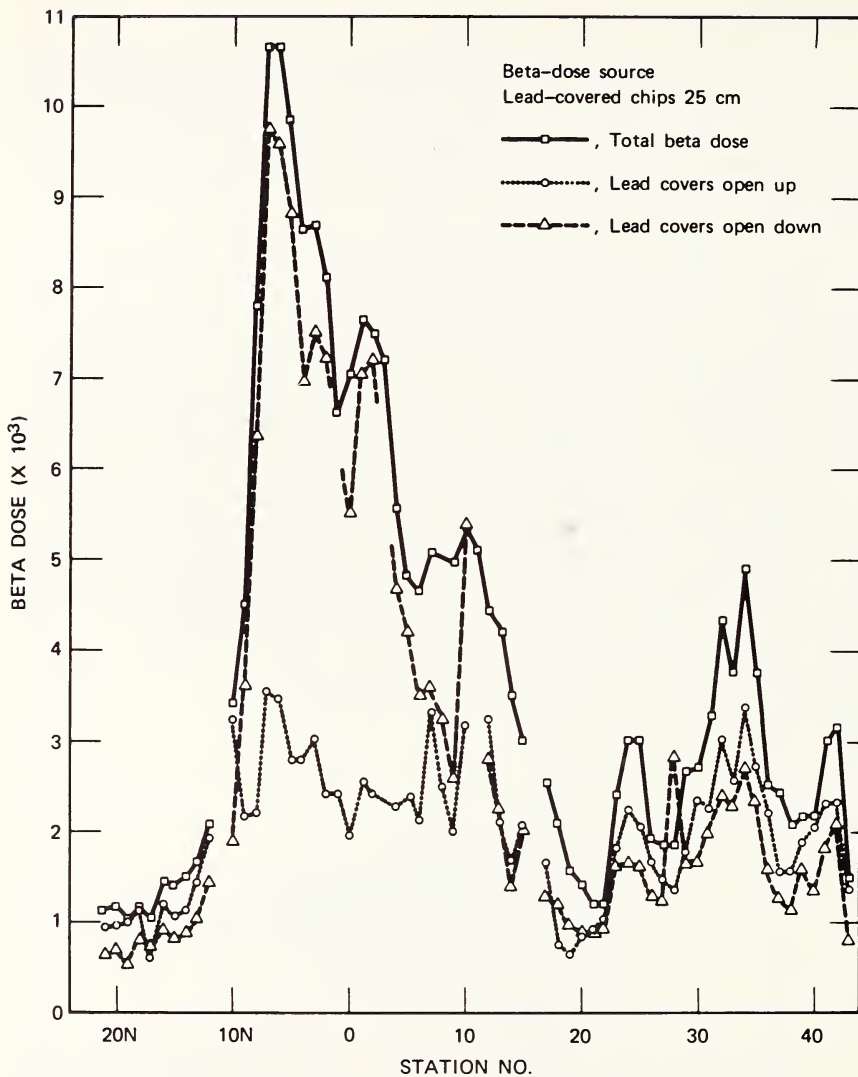

Fig. 9 Distribution of beta source in the Schooner event.

shielding presented interesting information for the interpretation of the beta source. The beta distribution data in Fig. 9 show that in the major fallout pattern (centered at Station 7N) the TLD chips with lead covers open toward the ground experienced three times the beta dose of those open toward the sky. In a secondary peak near Station 33, the contributions are essentially equal; the chips exposed to the sky show a slight additional beta dose compared to those open toward the ground.

The marked differences in the absorbed dose observed at Cabriole in the fronts, tops, and backs of shrubs were not detected. Instead, dosimeters placed at these positions received the same dose within the statistics of the measurements. Also, the type of vegetation damage observed after this event contrasted sharply with that observed at Cabriole.

The effects of close-in fallout on vegetation at the Schooner site are described in detail by Rhoads et al.^{1,2} in this volume.

Direct Dose Measurements for Future Events

To supplement the method of determining the energy fluence and the interpretation in terms of absorbed dose, we can use a dosimeter material directly to measure absorbed dose if it absorbs only a negligible portion of the incident radiation (i.e., if, considering an absorption of the form $E_0 e^{-\mu t}$, the material is "thin" under the condition that $\mu t \approx 0$).

From the experience gained in measuring depth dose in cratering fallout fields, we determined that a direct-reading dosimeter having a small thickness compared with the beta range of 325 mg/cm^2 could be made. This dosimeter, which consists of a 0.012-in. cube of hot-pressed $\text{CaF}_2\text{-Mn}$, was found to have a stable geometry, and measurements made with it in radiation fields were consistent within a probable error of $\pm 3 \text{ R}$.

This small cube can be placed directly alongside a stem, leaf, or branch or at a meristem; thus dosimetric measurements can be made at the vital points of interest to ecological studies. The gamma-ray contributions can be evaluated in a manner similar to that of the fluence measurements by shielding with sufficient material to absorb electrons entirely while producing a negligible effect on the gamma-ray component.

In summary, the direct measurement of absorbed dose by the small, 12-mil cubes of $\text{CaF}_2\text{-Mn}$ greatly simplifies the logistics of making dosimetry measurements on cratering events. Such dosimeters have been fabricated for use in ecological and environmental studies of fallout effects during any future events.

ACKNOWLEDGMENT

This work was done under Contract No. AT(29-1)-1183 between Environmental Sciences Branch, Division of Biology and Medicine, U. S. Atomic Energy Commission, and EG&G, Inc., Santa Barbara Division.

REFERENCES

1. Roy Overstreet et al., Preliminary Report, Trinity Survey Program, August 1947, USAEC Report, University of California, Los Angeles, 1947.

2. S. L. Warren and A. W. Bellamay (Comps.), The 1948 Radiological and Biological Survey of Areas in New Mexico Affected by the First Atomic Bomb Detonation, USAEC Report UCLA-32, University of California, Los Angeles, Oct. 12, 1949.
3. K. H. Larson et al., Alpha Activity Due to the 1945 Atomic Bomb Detonation at Trinity, Alamogordo, New Mexico, USAEC Report UCLA-108, University of California, Los Angeles, Jan. 5, 1951.
4. J. L. Leitch, Summary of the Radiological Finding in Animals from the Biological Surveys 1947, 1948, 1949, and 1950, USAEC Report UCLA-111, University of California, Los Angeles, Feb. 7, 1951.
5. K. H. Larson, J. H. Olafson, J. W. Neel, W. F. Dunn, S. H. Gordon, and B. Gillooly, The 1949 and 1950 Radiological Soil Survey of Fission Product Contamination and Some Soil-Plant Interrelationships of Areas in New Mexico Affected by the First Atomic Bomb Detonation, USAEC Report UCLA-140, University of California, Los Angeles, May 31, 1951.
6. Lora M. Shields and P. V. Wells, Effects of Nuclear Testing on Desert Vegetation, *Science*, **22**: 38-40 (1962).
7. W. H. Rickard and L. M. Shields, An Early Stage in the Plant Recolonization of a Nuclear Target Area, *Radiat. Bot.*, **3**: 41-44 (1963).
8. W. E. Martin, Close-in Effects of Nuclear Excavation and Radiation on Desert Vegetation, abstract in *Radiation Effects on Natural Populations*, a Colloquium Held in Philadelphia, May 23, 1965, George A. Sacher (Ed.), USAEC file No. NP-16374, pp. 7-9, Argonne National Laboratory, January 1966.
9. Janice C. Beatley, Effects of Radioactive and Non-Radioactive Dust upon *Larrea divaricata Cav.*, Nevada Test Site, *Health Phys.*, **11**: 1621-1625 (1965).
10. W. A. Rhoads, Robert B. Platt, and Robert A. Harvey, Radiosensitivity of Certain Perennial Shrub Species Based on a Study of the Nuclear Excavation Experiment, Palanquin, with Other Observations of Effects on the Vegetation, USAEC Report CEX-68.4, EG&G, Inc., May 1969.
11. W. A. Rhoads, R. B. Platt, R. A. Harvey, and E. M. Romney, Ecological and Environmental Effects from Local Fallout from Cabrioleet. I. Radiation Doses and Short-Term Effects on the Vegetation from Close-in Fallout, USAEC Report PNE-956, EG&G, Inc., June 25, 1969.
12. W. A. Rhoads, H. L. Ragsdale, and R. B. Platt, Radiation Doses to Vegetation from Close-in Fallout at Project Schooner, this volume.

THE IMPORTANCE OF TRITIUM IN THE CIVIL-DEFENSE CONTEXT

J. R. MARTIN and J. J. KORANDA

Lawrence Radiation Laboratory, Bio-Medical Division, University of California,
Livermore, California

ABSTRACT

The importance of tritium in the civil-defense context is assessed by comparing the dose rate and the 30-year dose integral for tritium from fusion with the external dose of gamma-emitting fission products.

The tritium dose is computed by assuming equilibration of fallout tritium with water in the biosphere and with the body water of man. The fission-product gamma dose for late-time dose-significant nuclides is tabulated in roentgens per hour per kiloton per square mile as a function of time.

Tritium is shown to be relatively unimportant in the civil-defense context when compared with the external gamma dose from an equal yield of fission products.

The survival of man in an environment contaminated with radioactive fallout after a nuclear attack is the basis on which the importance of tritium in the civil-defense context can be assessed. Although tritium is a weak beta emitter, the radiation hazard to man can be significant because of the high yield of residual tritium from fusion devices. Also, tritium is relatively mobile and, as tritiated water, becomes rapidly dispersed in the environment where it is available for ingestion by man. On the other hand, the hazard is reduced somewhat by the dilution of tritium with the large amount of water in the environment.

The importance of any single isotope can only be compared with respect to other radioisotopes produced in a nuclear explosion. As a first estimate, therefore, the radiation hazard to man from residual tritium is compared with that from fission-product radioactivity.

When certain reasonable assumptions are made, the dose rate as a function of time and the 30-year dose integral can be determined per unit area and unit

explosive yield for residual tritium from fusion and for fission-product radioisotopes. For example, in the civil-defense context we assume a 2-week shelter period following the detonation of nuclear weapons with equal parts of fission and fusion. The 2-week shelter period eliminates blast, heat, shock-wave, and prompt-radiation effects from consideration. The assumption of equal parts of fission and fusion is necessary to normalize the explosive yield. The results obtained in this study can be scaled directly for any other ratio of fission to fusion.

Finally, we assume that fallout is uniformly deposited over an area of 1 sq mile per kiloton of yield. The essential consideration of this assumption is that tritium is distributed in the same manner as the fission products are. Any deviation from uniform distribution will not affect the results of this study as long as the distribution of tritium and of fission-product fallout changes in the same way. The results can also be scaled directly for any area of deposition per unit explosive yield.

Fleming¹ provides a convenient summary of external gamma dose as a function of time for uniformly deposited, unfractionated plutonium fission products in roentgens per hour per kiloton per square mile. To simplify, we will consider in comparison with the tritium dose only the nuclides that contribute significantly to the external gamma dose at late times. Many short-lived fission products are, of course, eliminated from consideration by the 2-week shelter period.

The tritium dose rate can be expressed in the same terms as the gamma dose rate if we assume that the uniformly distributed residual tritium yield is thoroughly mixed and in equilibrium with water in the fallout environment by the end of the 2-week shelter period. The specific-activity approach then permits dose calculations based on equilibration of tritiated water with vegetation, livestock, and man.

TRITIUM DOSIMETRY

To use the specific-activity approach, we must determine the water compartment of the biosphere in which tritium fallout will be mixed. The water compartment can be estimated from studies of the behavior of tritium in a desert ecosystem by Koranda and Martin² and in the tropical rain-forest ecosystem by Martin et al.³ and Jordan et al.⁴ These studies show that tritium behavior in the environment is influenced largely by rainfall. These diverse ecosystems probably represent the extremes of the range of rainfall, from the low of 5 in./year in the desert to the high of 100 in./year in the rain forest.

Tritium behavior can be considered in terms of a simple mixed-tank model. A single deposition of tritium is assumed to mix completely with a finite soil-water volume defined as the water-compartment capacity, C . The incoming flux of rainwater, F , which represents the flow through the compartment, is

assumed to be immediately and completely mixed with the water compartment. The outgoing flux of water from the compartment, which must be equal to the incoming flux, contains the instantaneously diluted concentration of tritium. Thus the physical removal of tritium is exponential with time. The mean residence time for tritium, T , defined as the average time a tritium atom remains in the compartment, is given by the ratio of the capacity, C , to the flux, F :

$$T = \frac{C}{F} \quad (1)$$

The exponential physical removal of tritium was demonstrated in the desert and rain-forest ecosystem studies. The capacity of the water compartment, C , can be determined from a measurement of the flux of rainwater, F , and the observed mean residence time, T :

$$C = FT \quad (2)$$

In the rain-forest experiment described by Jordan et al.,⁴ the surface deposit of tritium moved down into the soil profile, giving a peaked distribution with depth. The peak tritium concentration moved deeper into the soil profile and became more diffuse with time. Martin et al.³ described how the residence time was determined by plotting the integrals of the tritium depth-distribution curves with time. The mean residence time for tritium in the rain-forest ecosystem following a surface application was 42 days. The incoming flux of rain was 100 in./year, or 6.66 kg/m²/day; thus, from Eq. 2, the capacity of the water compartment is

$$C = FT = 6.66 \times 42 = 280 \text{ kg/m}^2 \quad (2a)$$

A similar pattern of tritium behavior with time was observed in the soil of the desert ecosystem at the Sedan crater. The mean residence time for tritium determined by Martin and Koranda⁵ was 18.8 months, or 570 days. The incoming flux of rain was only 5 in./year, or 0.35 kg/m²/day; thus the water-compartment capacity is

$$C = FT = 0.35 \times 570 = 200 \text{ kg/m}^2 \quad (2b)$$

The agreement in the calculated values for the water-compartment capacity of these diverse ecosystems can be explained by the difference in the depth of the zone of interaction of their respective soils. Although the rain-forest soil had a relatively high average water content, only a shallow layer of soil water mixed with incoming rain. The water compartment of the wet tropical rain-forest soil corresponded to a depth zone of less than 2 ft. In the dry desert soils, significant interaction of tritium was observed at depths of 6 ft. The estimated water-

compartment capacity for the biosphere was therefore taken to be the average value, 240 kg/m².

This estimate is conservatively low with respect to dose calculations because desert plants growing at the Sedan crater typically had tritium concentrations in their water; this indicated a water compartment of three to nine times that of the measured value. There appeared to be greater dilution of the tritium than could be accounted for by the water compartment. This is apparently due to the fact that the tritium is not uniformly distributed in the soil. The plants draw water from selected depths in the soil, whereas the water compartment is determined from the integrated depth profile.

The tritium concentration in the biosphere can be calculated from a tritium yield of 2 g/kt dispersed over a 1 sq mile area and diluted by the water compartment of 240 kg/m². The resulting specific activity of tritium, A, is

$$A = \frac{(2 \text{ g/kt})(9800 \text{ Ci/g}) (3.86 \times 10^{-7} \text{ sq mile/m}^2)}{240 \text{ kg/m}^2} \\ = 3.15 \times 10^{-5} \text{ Ci/kg/kt/sq mile} \quad (3)$$

If a man is equilibrated with this specific activity, the resulting dose rate, D₀, is

$$D_0 = (3.15 \times 10^{-5} \text{ Ci/kg/kt/sq mile}) (7.44 \text{ R/hr/Ci/kg}) \\ = 2.34 \times 10^{-4} \text{ R/hr/kt/sq mile} \quad (4)$$

The dose rate, D_t, at any time, t, is

$$D_t = D_0 e^{-(\lambda_p + \lambda_r)t} \quad (5)$$

where λ_r is the radiological decay constant for tritium (0.0565 year⁻¹) and λ_p is the physical-removal decay constant.

The integrated dose, I, from t = 0 to t = t, is given by

$$I_t = \frac{D_0 [1 - e^{-(\lambda_p + \lambda_r)t}]}{\lambda_p + \lambda_r} \quad (6)$$

The 30-year dose integral for no physical removal (λ_p = 0) is

$$I_{30} = \frac{2.34 \times 10^{-4}}{0.0565} (8760 \text{ hr/year}) [1 - e^{-30(0.0565)}] \text{ R/kt/sq mile} \quad (7)$$

$$I_{30} = 30 \text{ R/kt/sq mile} \quad (7a)$$

If allowance is made for the physical residence time of tritium, the 30-year dose integral is much lower. Even when the most conservative observed value,

18.8 months ($\lambda_p = 0.639 \text{ year}^{-1}$), in the desert ecosystem is used for the physical residence time, the dose integral becomes

$$I_{30}' = 3 \text{ R/kt/sq mile} \quad (7b)$$

FISSION-PRODUCT DOSIMETRY

The dose rate at various times and the 2-week to 30-year dose integral for the late-time dose-significant gamma-emitting fission products are given in Table 1. The dose rates were taken directly from Fleming's data,¹ in which the point of exposure is 3 ft above a smooth infinite plane uniformly contaminated with the nuclide in question. The late-time dose-significant nuclides are those which contribute 1% or more of the total external gamma dose integral from 2 weeks to 30 years. The nuclides listed account for more than 95% of the dose rate at any time after 2 weeks postdetonation.

At early times after the 2-week shelter period, the dose rate is due mainly to fission products with half-lives in the range of several days to several weeks. The contribution of ^{140}Ba — ^{140}La , for example, is half the total dose rate at $t = 2$ weeks. The contribution of these nuclides falls off rapidly with time because of their relatively short half-lives. The long-lived nuclides, such as ^{106}Ru — ^{106}Rh and ^{137}Cs , contribute only a small fraction of the dose rate at $t = 2$ weeks but become increasingly significant at later times. At $t = 2$ years, for example, these nuclides account for 85% of the total external gamma dose rate of the uniformly deposited fission products.

In the period from 2 weeks to 2 years, the major fraction of the dose rate is from nuclides with half-lives of the order of months which have relatively high yields, such as ^{95}Zr — ^{95}Nb and ^{103}Ru . These nuclides account for more than 85% of the dose rate at $t = 20$ weeks and more than 60% of the dose rate at $t = 50$ weeks. These nuclides also account for more than 50% of the total 2-week to 30-year dose integral.

Except for ^{95}Nb , the 2-week to 30-year dose integrals are computed for each significant nuclide by means of Eq. 6 with the physical decay constant $\lambda_p = 0$. In computing the ^{95}Nb dose integral, we must consider its growth from the decay of ^{95}Zr . Since all other nuclides are produced at early times or have short-lived precursors, the change in dose rate with time is due only to radiological decay. The sum of all individual contributors gives a total 2-week to 30-year dose integral of 1124 R/kt/sq mile.

Since the dose rate decreases rapidly with time, most of the integrated dose is delivered at early times postdetonation. For example, during the period from 2 to 20 weeks, 680 R/kt/sq mile, or more than 60% of the total 2-week to 30-year dose integral, is delivered. An additional 200 R/kt/sq mile is delivered in the period from 20 to 50 weeks. Thus nearly 80% of the 30-year total integrated gamma dose is delivered during the first year postdetonation.

Table 1
LATE-TIME DOSE-SIGNIFICANT GAMMA-EMITTING FISSION PRODUCTS

Nuclide	Dose rate, R/hr/kt/sq mile				Dose integral (2 weeks to 30 years), R/kt/sq mile
	2 weeks	20 weeks	50 weeks	100 weeks	
^{95}Zr	9.5×10^{-2}	2.6×10^{-2}	2.6×10^{-3}	7.0×10^{-5}	214
^{95}Nb	2.5×10^{-2}	4.0×10^{-2}	6.0×10^{-3}	1.4×10^{-4}	225
^{103}Ru	1.4×10^{-1}	1.5×10^{-2}	4.0×10^{-4}		192
^{137}Cs — $^{137\text{m}}\text{Ba}$	8.2×10^{-4}	8.2×10^{-4}	8.2×10^{-4}	7.8×10^{-4}	156
^{106}Ru — ^{106}Rh	8.2×10^{-3}	6.3×10^{-3}	4.2×10^{-3}	2.2×10^{-3}	104
^{131}I	1.6×10^{-1}			5.5×10^{-4}	45
^{132}I	4.0×10^{-1}				45
^{136}Cs	1.0×10^{-1}				45
^{140}Ba — ^{140}La	1.2×10^0	1.0×10^{-4}			22
^{141}Ce	2.0×10^{-2}	1.1×10^{-3}			23
^{144}Ce — ^{144}Pr	1.2×10^{-3}	1.5×10^{-3}	5.0×10^{-4}	2.2×10^{-4}	11
^{147}Nd	2.8×10^{-2}	8.5×10^{-4}			11
Others	8.0×10^{-2}	1.0×10^{-5}	2.0×10^{-4}	1.0×10^{-4}	31
Total	2.26×10^0	9.24×10^{-2}	1.47×10^{-2}	3.51×10^{-3}	1.28×10^{-3}

COMPARISON OF TRITIUM DOSE WITH EXTERNAL GAMMA DOSE

The dose rate and the 2-week to 30-year dose integrals for tritium and for the gamma-emitting fission products are listed in Table 2 in roentgens per hour per kiloton per square mile and roentgens per kiloton per square mile, respectively. Table 3 lists the same data, except that here the tritium is assumed to have an 18.8-month residence time in the biosphere. It can be seen that in both cases the gamma dose rate is very much greater than the tritium dose rate, particularly at early times. The dose ratio is the ratio of the fission-product gamma to tritium dose rate.

At early times the dose ratio is about 10^4 , but it decreases rapidly to a ratio of about 70 at $t = 50$ weeks. The decline with time then becomes more gradual until a minimum ratio of 7 is reached at about $t = 4$ years. The ratio then increases slowly to a value of about 10 at $t = 30$ years. When the tritium residence time in the biosphere is assumed to be 18.8 months, the dose ratio has a minimum value of 50 at $t = 2$ years. In either case, the fission-product external gamma dose rate is always at least 7 times the tritium dose rate. When the physical residence time of tritium is considered, the tritium dose rate is never more than 2% of the external gamma dose from fission products.

The comparison of tritium with the external gamma dose from fission products can also be made on the basis of the 2-week to 30-year dose integral. The dose integral for the fission products is 1124 R/kt/sq mile; the value for tritium is 30 R/kt/sq mile, or 3 R/kt/sq mile when the residence time is considered. The fission-product dose integral is thus at least 37 times the tritium dose integral and is more likely to be 370 times as much.

CONCLUSIONS

This analysis was done on a relative scale. The importance of other internal beta emitters and of activation products can be assessed in a similar manner, relative to the fission-product external gamma scale. The full significance of the fallout-radiation hazard to the survival of man in the event of nuclear attack will depend on assessment of the absolute values of dose rate and dose integrals. The extent of preventive or corrective measures to be taken against the fallout radiation hazard can then be determined. Many hypothetical attack situations that go beyond the scope of this paper will have to be considered in making the assessment of the absolute hazard. The task can be simplified somewhat by the approach presented here, which shows that tritium is relatively unimportant in the civil-defense context when compared with the external gamma dose from fission products.

ACKNOWLEDGMENT

This work was performed under the auspices of the U. S. Atomic Energy Commission.

Table 2
ESTIMATED TRITIUM INTERNAL RADIATION DOSE COMPARED WITH FISSION-PRODUCT DOSE

	Dose rate, R/hr/kt/sq mile					Dose integral (2 weeks to 30 years), R/kt/sq mile
	2 weeks	20 weeks	50 weeks	100 weeks	200 weeks	
Total						
Fission products per kiloton of fission	2.26×10^0	9.24×10^{-2}	1.47×10^{-2}	3.51×10^{-3}	1.28×10^{-3}	4.1×10^{-4}
Tritium						1124
per kiloton of fusion	2.33×10^{-4}	2.29×10^{-4}	2.22×10^{-4}	2.10×10^{-4}	1.88×10^{-4}	4.29×10^{-5}
Dose ratio						30
Fission products	$\sim 10^4$	400	70	17	7	10
Tritium						37

Table 3
 ESTIMATED TRITIUM INTERNAL RADIATION DOSE COMPARED WITH FISSION-PRODUCT
 DOSE WITH THE USE OF AN 18.8-MONTH RESIDENCE TIME FOR TRITIUM

	Dose rate, R/hr/kt/sq mile					30 years	Dose integral, (2 weeks to 30 years), R/kt/sq mile
	2 weeks	20 weeks	50 weeks	100 weeks	200 weeks		
Total							
Fission products per kiloton of fission	2.26×10^0	9.24×10^{-2}	1.47×10^{-2}	3.51×10^{-3}	1.28×10^{-3}	4.1×10^{-4}	1124
Tritium per kiloton of fusion	2.28×10^{-4}	1.82×10^{-4}	1.26×10^{-4}	6.74×10^{-5}	1.94×10^{-5}	8.0×10^{-10}	3
Dose ratio <u>Fission products</u> Tritium	$\sim 10^4$	500	120	50	70	5×10^5	370

REFERENCES

1. E. H. Fleming, Jr., The Fission Product Decay Chains ^{239}Pu with Fission Spectrum Neutrons. Vol. III. Roentgens per Hour per Kiloton per Square Mile vs. Time, USAEC Report UCRL-50243, Lawrence Radiation Laboratory, University of California, Mar. 31, 1967.
2. J. J. Koranda and J. R. Martin, Persistence of Radionuclides at Sites of Nuclear Detonations, in *Biological Implications of the Nuclear Age*, Livermore, Calif., Mar. 5-7, 1969, B. Shore and F. Hatch (Coordinators), AEC Symposium Series, No. 16 (CONF-690303), pp. 159-187, 1969.
3. J. R. Martin, C. F. Jordan, J. J. Koranda, and J. R. Kline, Radioecological Studies of Tritium Movement in a Tropical Rain Forest, in Symposium on Engineering with Nuclear Explosives, Las Vegas, Nev., Jan. 14-16, 1970, USAEC Report CONF-700101 (Vol. 1), pp. 422-438, American Nuclear Society, May 1970.
4. C. F. Jordan, J. J. Koranda, J. R. Kline, and J. R. Martin, Tritium Movement in a Tropical Ecosystem, *Bioscience*, 20(14): 807 (1970).
5. J. R. Martin and J. J. Koranda, Distribution, Residence Time and Inventory of Tritium in Sedan Crater Ejecta, USAEC Report UCRL-72572, Lawrence Radiation Laboratory, University of California, Nov. 10, 1970; also *Nucl. Technol.*, in preparation.

PROPERTIES OF FALLOUT IMPORTANT TO AGRICULTURE

CARL F. MILLER

The Systems Operations Corporation, Hallock, Minnesota

ABSTRACT

The intrinsic properties of fallout associated with radiological hazards which could affect agricultural operations in the postattack period of a nuclear war include: (1) the radionuclide composition of the fallout material, which determines the energy composition of the gamma and beta radiation emitted, (2) the physical and chemical properties of the fallout particles (such as size, shape, composition, structure, and solubility) which influence their retention by surfaces, and (3) the solubility and biological availability of specific radionuclides. In terms of crop or agricultural-product output, both operational factors (effects on man and his social system) and biological factors (response of plants and animals) would be important.

Since the degree of the hazard to the food-producing agricultural systems would generally depend more on external parameters (such as the available weapon system, form or mode of attack, level of attack, explosive yield of weapons, relative heights of burst, and local and regional weather patterns) than on the properties of the fallout, these parameters are discussed in detail.

A major recent development in weapon systems which could have a significant impact on the type and extent of hazard to agriculture in a nuclear war is the Multiple Independent Targeted Reentry Vehicle (MIRV). Estimates of MIRV system capabilities, especially in terms of using many smaller-yield warheads on many smaller targets, are used to identify several important implications for future civil-defense planning and the role of civil-defense capabilities in the relative deterrence posture. If sufficient fallout shelters with protection factors of 130 or more were available for the U. S. population, it appears that the U.S.S.R. could not deploy sufficient SS-9 missiles to assure the destruction of the U. S. population within the next 800 years (even with MIRV) using currently available technology. Also, the effect of MIRV and the associated lower-yield warheads would be to almost eliminate the widespread fallout effects previously estimated for attacks in which land-surface detonations of weapons in the megaton-yield range have been postulated; a comparable degree of effect on agriculture might be achieved from attacks that are designed to kill more than 65% of the U. S. population if all detonations in rural areas were surface bursts.

The more important properties of fallout which could significantly affect agricultural operations after a nuclear war are those related to the total gamma- and beta-radiation emissions from the particles and the physical and chemical properties of the particles which influence their retention by plant and animal surfaces. In addition, physiochemical properties of the fallout, such as the solubility of individual radionuclides, can become important radiological-hazard problems in the production and consumption of specific agricultural products. A well-publicized example of this is the relative solubility of ^{131}I and its accumulation in milk produced by cows that have ingested fallout-contaminated food and water.

In terms of radiobiological effects to agriculturally important plants and animals, previous analyses have shown that the major cause of radiation damage would be the exposure of temporal units of the biota of rural farmland ecosystems to ionizing radiation.¹ Under the subject of longer-term ecological effects, the major concern would be with the secondary effects to functional units of the biosphere including biological populations, communities, and ecosystems.² Secondary effects, in contrast to direct effects, are disturbances and injury or damage, usually caused by the direct effects, which do not become important or do not develop until some time later. One property of fallout that could affect the relative severity of short-term and long-term effects on agricultural plants and animals is the combined decay rate of the radionuclides in the fallout; another property is the energy spectrum of the absorbed radiation.

SOURCE OF RADIOLOGICAL INJURY OR DAMAGE

In a nuclear explosion more than a hundred radioactive fission-product nuclides and many additional neutron-induced radionuclides are produced. This radioactive mixture initially consists of radionuclides with radioactivity-decay half-life values that vary from a fraction of a second to many years. Since most of the radionuclides emit both beta particles and gamma rays when they disintegrate, these two types of ionizing radiation are present in a fallout environment as potential causes of biological damage to living tissue. The presence of all these radionuclides in an ecosystem thus constitutes a source of radiological hazard from fallout. The major radiological hazard to man is external gamma radiation from deposited fallout; this fact requires special recognition both in damage-assessment studies and in civil-defense planning.

Fallout particles from land-surface detonations as nuclear-radiation sources consist of fused, sintered, and unchanged grains of soil minerals or other materials present at the point of detonation.³ Also present to a minor extent in fallout particles are inert materials from the weapon or warhead, as well as the radioactive elements produced in the fission and neutron-capture processes occurring at detonation. Roughly, the relative amounts of soil minerals, bomb-construction materials, and radioactive elements in fallout particles are

(1) up to 1 Mt of soil per megaton of total weapon yield, (2) of the order of 1 ton of warhead materials per megaton of total weapon yield, (3) about 120 lb of fission products per megaton of fission yield, and (4) about 100 to 200 lb of induced radioactive atoms per megaton of total yield.

Analyses of fallout particles from surface and near-surface detonations collected at weapons tests at both the Eniwetok Proving Ground and the Nevada Test Site show that the radioactive elements are either within the interior of fused and sintered particles or are attached to the exterior layers of all three types of particles.³ Larger fallout particles are formed, not by the condensation of vaporized soil, but from individual or agglomerated soil particles that originally either existed as single soil grains or were produced through the breakup of a fused mass of liquid soil or rock. All three types of particles are drawn into the rising fireball and apparently serve as collectors for small vapor-condensed particles and as condensation centers for vaporized fission-product and radioactive neutron-induced atoms.

On the basis of physiochemical properties of common metallic oxides of the chemical elements in soil and coral, it can be concluded that the fallout-formation process does not begin until the fireball temperature (or the temperature of the gaseous material in the fireball) has decreased to about 3000°K , because at higher temperatures all materials tend to dissociate rather than to condense. As the fireball temperature decreases below about 3000°K , vapor-condensation processes should take place to produce very small liquid particles. Such small particles have been observed in worldwide fallout collections and as attached particles on unchanged coral grains in the fallout materials collected from weapons tests at the Eniwetok Proving Ground.

As the fireball rises and cools and the crater materials are drawn up into its volume, the thermal action at the surfaces of entering molten particles should gradually change from a vaporization process to a condensation process in which the less volatile fission products condense onto and diffuse into the liquid phase of the particles. In addition, the larger molten soil particles, as they circulate through the fireball volume, would rapidly form agglomerates with a large fraction of the smaller, previously formed, vapor-condensed particles. Particles entering the fireball volume at later times may be heated to sintering temperature or may never be thermally altered.

As the surface temperature of the particles decreases, the rate of diffusion of the condensed radioactive atoms into the interiors of the particles should also decrease so that the more volatile of the radioactive elements, which can condense only at lower temperatures, collect and concentrate on the exterior surface of the particles. Also, radioactive daughter atoms (even if not volatile) formed at later times from volatile parent nuclides, such as those from rare-gas elements, would be concentrated on the exteriors of the smaller particles. Because of the differences in volatility as a function of temperature among the various fission-product elements, fractional condensation would be expected to

occur throughout the whole fallout-formation process. The observed degree of solubility and biological availability of such radionuclides as ^{89}Sr , ^{90}Sr , and ^{137}Cs from the fallout of nuclear-weapons tests strongly supports these views regarding the condensation process.⁴

In general, two rather distinct periods of fallout formation by condensation processes have been postulated.³ In the first period the condensation of volatile radioelements is considered to occur by deposition onto and diffusion into large molten soil particles and by agglomeration with smaller particles. The radioelements thus condensed would become fused within the volumes of the molten particles when they cooled and solidified. In the second period the remaining volatile gaseous radioelements condense onto the surfaces of relatively cold solid particles (most of which consist of late-entering, thermally unaltered grains of soil).

The significant chemical property associated with the amount of a radioelement that condenses during the second period of formation is its potential solubility, whereby it can become biologically available for later assimilation by plants and animals. The more volatile radioelements in fallout are more soluble and more biologically available than the refractory elements. However, the fractional degree to which each element condenses in either period of condensation is expected to depend very much on both the temperature and the rate of temperature decrease, which determine the conditions and times at which diffusion into the particle effectively ceases and at which the condensing radioelement begins to concentrate on the surface of the particles.

If all the materials produced in a land-surface nuclear detonation and all entering the fireball volume remained together for the first 5 or 10 min after detonation, the radioactive composition and the subsequent radioactive decay (and nuclide solubility) would be about the same for all fallout particles. However, it is known that all the entering particles do not remain together in the fireball and cloud for such periods of time. Immediately after the fireball expands to maximum size it begins to rise in the air. The upward movement of the hot gases sets in motion a large-scale toroidal circulation because of the drag forces of the surrounding air. This toroidal motion, with circulation velocities in excess of 100 mph, is probably responsible for setting up air motions whose forces are sufficiently strong to pull the blast-loosened soil from the crater and crater lip into the rising fireball.

The circulation of the particles in the toroid should result in rapid separation of the larger particles from the circulating mass of condensing gases and should, by centrifugal force, move them to the periphery of the toroid. When the circulating particles reach the periphery or the bottom of the cloud and the pull of gravity begins to exceed the upward drag forces of the air near the base of the rising cloud, the particles should begin falling toward the earth. Other particles of the same size that are not yet near the periphery of the toroid may continue to circulate for a much longer time before they leave the base of the cloud.

These views of particle circulation and formation are suggested by (1) the relatively long period over which particles of a given size arrive on the ground, (2) the relatively early initial arrival times for close-in fallout, (3) the variation in composition of the radioelements carried by particles of different sizes, and (4) the variation in specific activity and radioelement composition among particles of a given size.

The concentration of the volatile radioelements in the radioactive compositions carried by the larger particles is generally low. This relatively low concentration could occur only through the earlier ejection of the large particles from the volume of the fireball containing the radioelements (vapors plus small vapor-condensed particles). In addition, the large fallout particles from many low tower detonations do not contain or carry any soluble radioelements; therefore these particles must have been ejected from the rising fireball or cloud when the particle surfaces were still at a very high temperature. Thus the toroidal motion is considered to be partially responsible for the observed differences in gross radioactive decay and biological availability of different radioelements carried by fallout particles of different diameters.

The toroidal motion, which apparently causes early ejection of the larger particles (i.e., early with respect to time-of-fall from the height of the stabilized cloud), can also cause prolonged apparent buoyancy of the smaller particles. The smaller particles should circulate for longer times and should remain in the toroid where they could adsorb the more volatile radioactive elements on their surfaces. Essentially all fallout particles, except those with diameters less than about 50 to 80 μ , apparently leave the cloud volume under influences of toroidal circulation.

No observed data exist on the properties of fallout from detonations on soils similar to those of likely targets in a nuclear war. In fact, only a few detonations at the Eniwetok Proving Ground and the Nevada Test Site have provided data useful for the development of fallout models for land-surface detonations. All the large-yield test devices were detonated over water, on coral atolls, or in the air. Most test detonations in the yield range of 1 kt to 1 Mt were mounted on towers. Consequently there is no evidence proving that all types of fallout information obtained from the weapons tests (even under suitable detonation conditions) are satisfactory for evaluating computational procedures developed to give quantitative estimates of properties of the fallout particles, as well as of their distribution over the country as a consequence of an assumed set of nuclear detonations on specified targets in the continental United States. Further theoretical developments and supporting experimental work are needed to evaluate and improve the validity of some available input data used in the formulation of many fallout models.

The radionuclides in worldwide fallout from high airbursts, in contrast to those described for the close-in local fallout from near-surface detonations, are generally quite soluble. Therefore essentially all the radionuclides in long-range worldwide fallout are biologically available. Fused-type particles formed from

the warhead or bomb materials have been identified and found in fairly large numbers in stratospheric collections of bomb debris.⁵ But a large fraction of the worldwide fallout from a large-yield nuclear airburst is apparently formed in the stratosphere at some time after detonation through processes of coagulation and coprecipitation of the radioactive atoms with the natural stratospheric aerosol particles. These particles, composed mainly of water-soluble ammonium sulfate compounds, apparently serve as carriers for eventually returning the longer-lived radioactive elements to earth.

Under all conditions of detonation that lead to the production of fallout, the form and properties of the fallout particles are determined during the cooling period of the fireball and cloud; for the decay products of gaseous and several other radioelements, the attachment to particles occurs at later times. The materials in or entering the fireball at these times are particularly important factors in determining the properties of the fallout particles. These formation processes set the stage for all subsequent radiological interactions between the fallout materials and the biological and ecological environments in which they deposit.

One of the chief difficulties in predicting fallout levels at a given location, in addition to the problem of defining the fallout-particle-cloud source, lies in the problems associated with analyzing and predicting the wind fields. The winds at all altitudes through which the particles fall, of course, determine how the fallout particles are distributed over the earth's surface. Other major factors for which very little accurate data exist, especially for fallout from detonations over silicate soils, include (1) variation of the specific activity of fallout with particle size and (2) influence of weapon yield, burst height, and environmental material (soils and other likely target materials) on the gross particle-size distribution of the fallout (i.e., by particle number, mass, or radioactivity content).

The radiation, chemical, and physical properties resulting from the fallout-formation processes and conditions may give rise to one or more of five major types of radiological hazard to biological species. These are (1) external gamma hazard, as mentioned for humans, (2) contact beta hazard, (3) beta-field hazard, (4) internal hazard from ingested radionuclides, and (5) inhalation hazard.

The nature of the hazard and the response of biological species to it are perhaps better known and understood for external gamma radiation than for the other four hazards. Under most exposure situations occurring under nuclear war conditions, the external gamma hazard would be the major cause of serious direct radiation injury to large biological species.

The contact beta hazard could arise when fresh fallout particles remained in contact with biological tissue for some period of time. Humans could easily avoid this type of exposure by wiping or brushing fallout particles from exposed skin. This hazard would develop only during and shortly after fallout deposition. After several days the fallout particles would no longer have the radioactive content necessary to cause serious damage to skin tissues. Some data on the retention of particles by humans⁶ and on skin doses to animals⁷ have been

reported. No reliable correlations of such data with fallout-deposition levels have yet been made, but unverified relations between the two have been proposed.⁸ A few sets of computations and experimental measurements have been made of the contact beta dose to plants;⁹ data on the retention of fallout particles by the foliage of many different types of plants have been reported.⁶

The beta-field hazard (sometimes called the "beta-bath" hazard) could occur in certain confined radiation source geometries for humans. It would be expected to be severe for small plants, small animals, and insects whose habitats become covered with the deposited fallout particles. In such geometries the beta-to-gamma ratio (i.e., the rad-to-roentgen ratio) would generally be between 30 to 100 for fallout-radiation compositions similar to those of past weapons tests. No mathematical models on the beta-field hazard to small plants and animals or insects are known to exist; however, some related work on this hazard was reported.^{10,11} The combined radiological hazards (external gamma, contact beta, and beta-field) for plants, animals, and insects should be considered in future research investigations.

The internal hazard from ingested radionuclides and the consequent pattern of exposure of humans, animals, plants, and insects to this hazard after a nuclear war would depend mainly on their uptake and assimilation of biologically available (soluble) radionuclides. Several major processes are involved in the entry of the radionuclides into food chains (or webs). The internal hazard from fallout is characterized mainly by the fact that, at least in humans and other large vertebrate animals, most of the radiation sources (e.g., radioactive atoms) tend to concentrate in specific body organs and that assimilation occurs according to the biochemical properties of specific radionuclides. Thus evaluations of the internal hazard must consider the behavior patterns of each radioelement in the fallout. Data on absorbed doses from ingestion of radionuclides by adult humans have been developed in a significant research effort conducted by Morgan and co-workers¹² over the past 15 years. Similar sets of data for the absorbed doses for young people during their growing years have yet to be developed. Kulp et al.¹³ developed a bone model for the uptake of ⁹⁰Sr in worldwide fallout. Models for estimating the absorbed dose from assimilation of radionuclides in organs of humans have been developed.¹⁴

The inhalation hazard would be associated with the inhalation and deposition in the respiratory system of small fallout particles of a narrow size range. All the available data on exposure of animals in fallout areas at weapons tests and in laboratories, on air-filter samples in various fallout environments, and on fallout-particle resuspension in air give negligible results for the inhalation hazard. Therefore this hazard is considered to be minor relative to other possible radiological hazards.

The major primary radiological hazards that apparently would cause most damage to farmland (and wild land) ecosystems are external gamma and beta radiation and internal beta radiation from assimilation of radionuclides. It is significant for biological repair and recovery processes that injury sustained from

external radiological hazards under nuclear war conditions would generally be more comparable to an acute assault than to a chronic assault, whereas the assimilation of radionuclides would be mainly a chronic exposure to low levels of nuclear radiation. The general effect of radionuclide cycling in species of ecosystems appears from all available data to be mainly a long-term public-health problem rather than a cause of injury leading to the death of biological species.

Because of the large variability in the radiosensitivity of plants according to species, age, and period between growth and reproduction cycles, the gross effects in plant population from exposure to gamma radiation would depend a great deal on the time of year, perhaps of month, when an attack occurred. Thus the total consequence would depend on the targeting pattern for many agricultural areas; the Midwestern states, for example, could receive high levels of fallout from high-yield surface detonations on missile sites in neighboring states and in the Rocky Mountain area.

RADIOLOGICAL DAMAGE ASSESSMENTS

Current Weapons Systems

In most damage-assessment analyses, military targets normally play an important role in establishing the pattern of weapon delivery for any hypothetical attack. For many military targets it is appropriate to assume ground-surface detonations to assure destruction of the target components. Therefore in such attack patterns, called counterforce attacks, a large amount of local fallout is produced. Furthermore, in such studies rather large weapon yields are customarily assigned to military targets, perhaps for consistency with the assured destruction concept.* The relative area of the continental United States within a given standard ($H + 1$) exposure-rate contour (using an open-field radiation source as the reference condition) as a function of attack level in total megatons detonated is shown in Fig. 1 (Ref. 15). The relative area of the continental United States at a given attack level is shown in Fig. 2 as a function of the standard exposure-rate-contour level.

For hypothetical nuclear attacks on the United States in which most individual weapon yields are assumed (or assigned) to be in the range of 1 to 10 Mt, pure counterforce attacks at attack levels very much larger than 10,000 Mt would not be realistic, at least on a first-strike basis, because of the limit in number of military targets. Thus the extrapolation of the solid lines in Fig. 1 to the higher attack levels probably does not represent any real situation.

*The assured destruction concept is an extension of the notion that a weapon system or attack pattern can be designed or deduced to perform as envisioned by calculation, within a specified degree of assurance or a stated degree of reliability, ipso facto. The concept is to some degree a technical embellishment evolved by military technicians and analysts to provide a logical basis for deterrence policies.

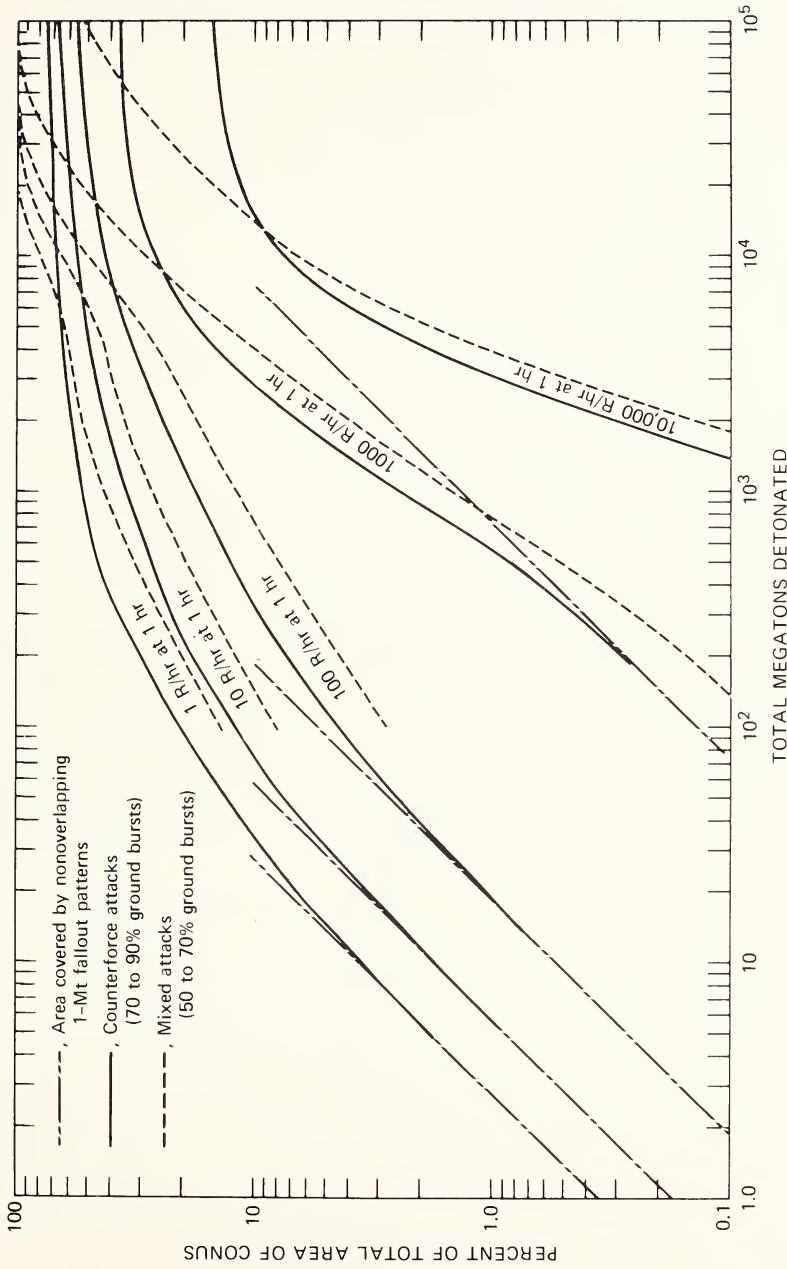

Fig. 1 Percent of area of the continental United States enclosed within selected I_5 contours as a function of attack weight (50% fission weapons).

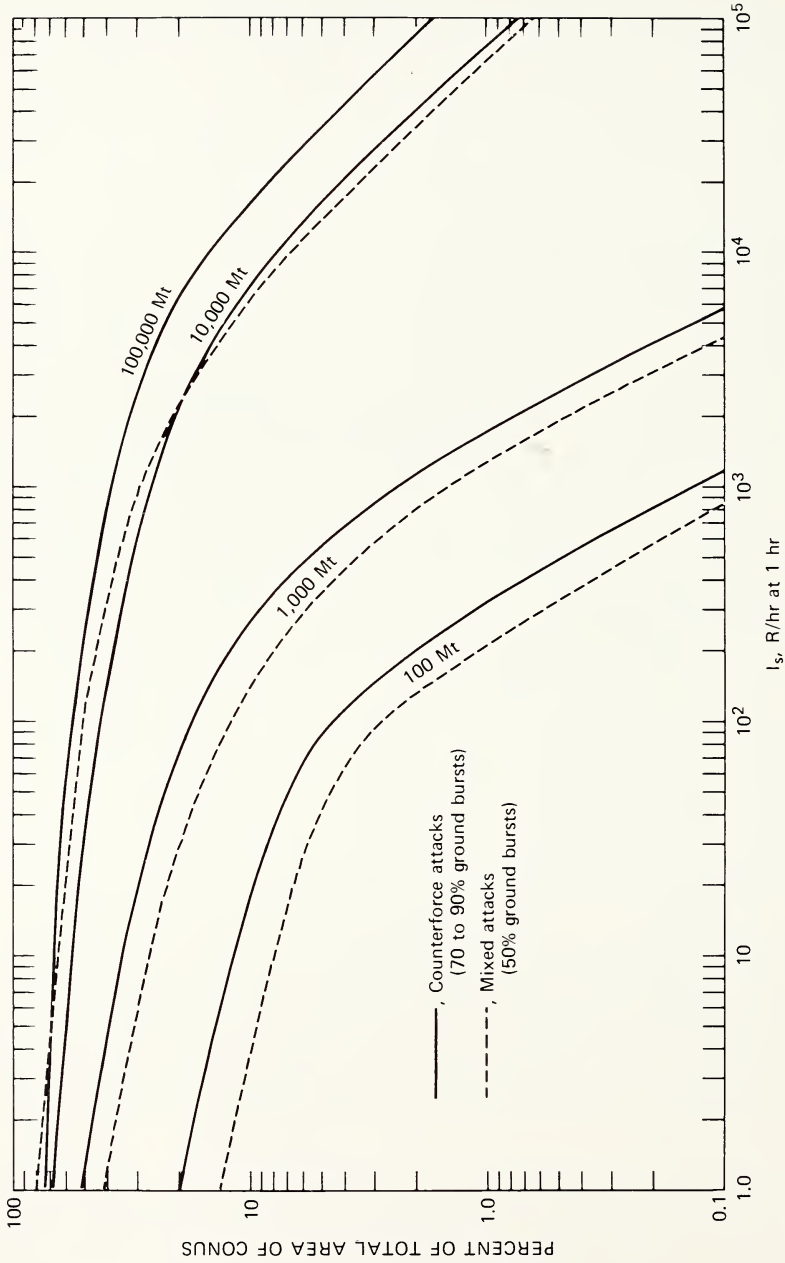

Fig. 2 Percent of area of the continental United States enclosed within I_s contours for selected attack weights (50% fission weapons).

As a general guide, I_s values up to 10 R/hr at 1 hr for fallout from fission weapons do not represent a serious direct radiological hazard to humans or to most other biological species. At I_s values greater than 100 R/hr at 1 hr, extended (but variable) stay times in shelter generally would be required to avoid possible effects of radiation sickness to humans. The I_s values of about 1000 R/hr at 1 hr and greater represent a serious radiological hazard for a fairly long time after attack; sickness and possible fatalities among poorly sheltered or unsheltered people could result. For I_s values of 10,000 R/hr at 1 hr and greater (radiation levels that generally would occur only as a result of overlapping fallout patterns), survival would be possible only in the best available fallout shelters with facilities for an extended stay time plus decontamination requirements for a reasonably short reoccupation time after attack.

For the weather conditions usually assumed for the hypothetical counterforce and mixed attacks (the latter may include some ground bursts on urban targets) with a total delivered explosive yield of less than about 10,000 Mt, the areas within extremely high I_s contours would enclose less than 10% of the land area of the United States, and essentially all such areas would be rural forested or agricultural areas. Since the current Soviet nuclear force capability is estimated to be more than 10,000 Mt,¹⁵ the delivery of such a force in a counterforce or mixed attack such as those represented in Figs. 1 and 2 would likely involve the coverage of more than 40% of the continental United States by I_s values of 100 R/hr at 1 hr and more than 25% of the area by I_s values of 1000 R/hr at 1 hr. Although these relative coverages of the land area are rather large, the associated degree of damage to or decrease in the yield of specific agricultural products by the respective exposures cannot be deduced from the curves of Figs. 1 and 2. To deduce damage, the relative geographic locations of the crops, targets, and assumed points of detonation, along with the meteorological inputs for each hypothetical attack must be considered; this procedure has been used in recent analyses.¹⁶

Future Weapon Systems

Over the past several years, one of the major developments in weapon systems has been the Multiple Independent Targeted Reentry Vehicle (MIRV). Certain information and estimates of apparent U.S.S.R. and U. S. progress and capabilities in the development of MIRV systems, especially with respect to their missile-carrying capacities, have been released to the press by various Department of Defense officials, including Secretary Laird. The following statements on Soviet nuclear force capabilities and MIRV system characteristics were provided by William Beecher¹⁷ in a special article in the *New York Times*, Oct. 28, 1969:

- As recently as last November, for example, the intelligence community predicted that the Soviet Union would stop deploying more intercontinental missiles when they had roughly equaled the 1054 in the American arsenal.

- The Soviet Union has in place or going into place about 1350 inter-continental ballistic missiles, roughly 300 more land-based units than the United States and 150 more than reported by American officials last spring.
- The Soviet Union has been testing a new swing-wing medium-range bomber, presumably for use against targets in Western Europe and Asia, even though it already has a fleet of 750 medium bombers. With aerial refueling, the new bomber could be used on round-trip strikes against the United States.
- The Russians are testing a new medium-range ballistic missile, though they already have more than 700 such missiles aimed at targets in Western Europe and Asia.
- The SS-9 can carry a single warhead of from 9 to 25 Mt (9 to 25 million tons of TNT) or three warheads of 4 to 5 Mt each. The SS-11 carries a warhead of 1 Mt, similar to the payload of the Minuteman missile.
- John S. Foster, Jr., the Pentagon's research and development chief, said that 420 SS-9's carrying three separately targetable warheads with one-quarter-mile accuracy could destroy about 95% of the 1000 Minutemen in their underground silos.
- The Soviet Union is now believed to have about 280 such giant missiles in various stages of construction. At the present rate of deployment, they could have the Minuteman killer force in three more years.
- The Minuteman-3 is designed to carry three warheads of about 100 kt, and the Poseidon submarine-based missiles, 10 warheads of 30 to 40 kt each. By comparison, the Soviet SS-9 is being tested with three warheads of about 5 Mt each, 50 times more powerful than each Minuteman-3 warhead.

On Jan. 6, 1970, the *Washington Daily News*, under a dateline from London, quoted the following statements:

- The Institute of Strategic Studies said the Soviet Union should have the capability to fit multiple nuclear warheads to its most powerful rockets by 1973.
- The influential study group, specializing in international defense developments, said the Soviets could have 500 of the multiple-warhead missiles ready for use by 1975.
- The multiple warheads are to be fitted to SS-9 Scarp rockets, "extremely powerful" three-stage missiles with a maximum range of 9800 miles, the report said. It estimated that each launcher cost between \$25 and \$30 million.
- About 250 of the SS-9's are believed to have been installed already in the Soviet Union, but these are not armed with the multiple warheads, the institute said.
- The Soviet SS-9 rocket originally was designed to carry a single warhead of between 10 and 25 Mt.

On January 7, 1970, Secretary of Defense Melvin Laird provided the following information to newsmen:

- The Russians could have a knockout missile force in place earlier than the 1974 period forecast to Congress last year.
- The discussion centered around Laird's estimate last summer that the Soviets could have about 420 of the huge SS-9 missiles in readiness by 1974. Such a force, Laird said then, could destroy 95% of this country's Minuteman missiles in a surprise first attack.
- He declined to say how many of the SS-9's, capable of hurling a single 25-Mt warhead or three warheads of 5 Mt each, are now in place or under construction. There have been unofficial estimates running up to about 279.

Defense officials, the news media, prominent scientists, and politicians have repeated similar information to the public over the past 10 months or more. The statements indicate that for the SS-9 missile the number of warheads apparently depends on the explosive yield of each warhead according to the relation

$$n_m = 866W^{-2/3} \quad (1)$$

where n_m is the maximum number of warheads carried by the missile and W is the explosive yield of each warhead. Similarly, for the Minuteman-3 missile

$$n_m = 65W^{-2/3} \quad (2)$$

and for the Poseidon and SS-11 missiles

$$n_m = 100W^{-2/3} \quad (3)$$

Values of n_m for the SS-9 missile, the maximum explosive load, and the total target area enclosed by the 35-psi overpressure contour for selected warhead yields are given in Table 1 (for the case where all weapons are airburst at the height for which the area enclosed by the selected overpressure contour is

Table 1
CALCULATED VALUES FOR SS-9 MISSILE*

W ($\frac{\text{megatons}}{\text{warhead}}$)	n_m ($\frac{\text{warheads}}{\text{missile}}$)	$n_m W$ ($\frac{\text{megatons}}{\text{missile}}$)	A_m (35 psi) ($\frac{\text{sq miles}}{\text{missile}}$)
0.1	40	4.0	31.8
0.3	19	5.7	31.4
1.0	8	8.0	29.5
3.0	4	12.0	30.7
10.0	1	10.0	17.1
25.0	1	25.0	31.9

maximized and at ground zero locations that are arranged in a hexagonal pattern in which the overpressure contours overlap in such a way that no point within the target receives less than 35 psi).

Table 1 shows that A_m (35 psi) is maximum at values of W which yield integer values of n_m in Eq. 1. For n_m equal to 2.0 warheads per missile, for example, W is 9.0 Mt. For this yield A_m (35 psi) is 31.9 sq miles/missile, although for the single 10-Mt warhead selected, A_m (35 psi) is only 17.1 sq miles/missile. In this case additional smaller warheads could be added to the capacity of the missile as appropriate to increase the value of A_m over that given. If the target area is less than 30 to 32 sq miles and n_m is more than 2, decoys could be used to replace some of the warheads.

Neglecting any possible effect of decoys and of active defense capabilities, the MIRV system using a maximum number of warheads, in contrast to a single warhead of maximum yield, apparently would provide no advantage in decreasing the number of missiles for imposing a selected minimum overpressure on a single target on an area basis. However, if the shape of the target area is considered, MIRV system weapons could achieve area enclosure within a selected overpressure contour with a smaller number of missiles and a smaller total explosive yield than could a single-warhead missile system. For example, a single SS-9 missile loaded with 40 100-kt warheads (4.0-Mt total yield) could, according to Table 1, enclose an area about 32 miles long and 1 mile wide within the 35-psi contour. Lengthwise coverage by the same overpressure contour would require five SS-9 missiles if each carried a single 25-Mt warhead (125-Mt total yield).

If the MIRV system could be employed with essentially no constraint on warhead dispersion among neighboring targets and if full use could be made of such capabilities to deliver warheads to targets, then any set of estimates of single-weapon missile force requirements may be directly converted to missile requirements for a system with MIRV. Under such conditions estimates of the number of SS-9 missiles required to cause specified levels of fatalities among the 1970 U. S. population sheltered in wood-frame structures exposed to selected minimum overpressures are given in Table 2 for weapon yields of 0.1, 1.0, and 10 Mt.* The lowest number of missiles for a given percentage of fatalities always occurs for a weapon yield of about 100 kt or less for the urban-center target areas.²⁰ Thus the general dependence of missile requirements on fatalities or area by a given overpressure contour relative to target size apparently ceases to be important for weapon yields less than about 100 kt. This independence is shown especially for the smaller high-density urban areas that would comprise the first set of targets for an antipopulation attack; a similar situation pertains for the smaller urban target areas listed in Table 2 in the range of 55 to 65% of the total population.

*These estimates are based on information from the Japanese experience at Hiroshima and Nagasaki in World War II as discussed in Refs. 15, 18, and 19.

Table 2

ESTIMATED MINIMUM NUMBER OF SS-9 MISSILES WITH MIRV REQUIRED FOR SPECIFIED LEVELS OF FATALITIES AMONG THE 1970 U. S. POPULATION SHELTERED IN WOOD-FRAME STRUCTURES

Fatalities, %	Minimum overpressure				
	5 psi	10 psi	15 psi	20 psi	35 psi
W = 0.1 Mt					
20	633	128	87	82	119
30	2,645*	528	220	184	250
40		5,770	470	348	473
50		21,820*	4,698	533	770
60			16,850	4,450	1,063
70			32,550*	12,210	5,310
80				51,630*	15,590
100					115,500*
W = 1.0 Mt					
20	1,237	187	114	100	137
30	10,950*	1,094	270	223	292
40		6,615	903	420	542
50		24,020*	5,454	833	870
60			18,530	5,063	1,179
70			35,430*	13,520	5,832
80				55,930*	16,920
100					124,500*
W = 10 Mt					
20	6,848	924	427	340	324
30	23,570*	1,541	1,408	707	669
40		16,260	6,178	1,707	1,173
50		46,000*	14,010	5,008	2,208
60			36,520	13,290	4,319
70			65,610*	26,910	14,270
80				100,900*	33,360
100					218,800*

* $F_f(\max)$ is 0.28 at 5 psi, 0.45 at 10 psi, 0.62 at 15 psi, 0.80 at 20 psi, and 1.00 at 35 psi.

In other words, a further significant reduction in overkill and wastage of explosive energy associated with the detonation of large-yield weapons on small-size targets would not be achieved by the use of weapons with yields less than 100 kt on U. S. urban centers as a target system. However, for attacks designed to cause more than about 65% fatalities under the conditions assumed in Table 2, the various states or the country as a whole would become a single

target, and on an area basis the number of missiles required would be essentially independent of weapon yield for missiles carrying maximum payload.

The Soviet's estimated 1970 intercontinental nuclear force, from the previously quoted statements, is approximately 11,000 Mt, assuming a one-way mission or refueling of 750 bombers carrying a payload of 5 Mt each, 1100 SS-11's carrying 1 Mt each, and 250 SS-9's carrying 25 Mt each. These estimates do not include the submarine force of perhaps 200 vessels, because it is assumed that its mission would be that of a reserve or second-strike force. Such a ready force, if delivered in an antipopulation attack with 100% reliability and accuracy in the most efficient manner (i.e., by allocating the 1-Mt weapons to densely populated cities with small areas and the 25-Mt weapons to less densely populated urban centers covering larger areas) utilizing full-target coverage by 20- or 35-psi overpressure contours, could result in fatalities amounting to about 42% of the population if all were sheltered in wood-frame structures. This percentage of fatalities is equivalent to the entire 1970 population of the 680 largest U. S. cities.

If this same nuclear striking force were converted to efficient and maneuverable MIRV systems with 100-kt warheads, the single 5-Mt warhead assumed for the bombers would convert to thirteen 100-kt warheads; the single 1-Mt warhead taken for the SS-11 would convert to four 100-kt warheads; and the single 25-Mt warhead for the SS-9 would convert to about forty 100-kt warheads. The combined striking power for these warheads is then 2375 Mt, which, if delivered according to the assumptions in Table 2, could produce about 52% fatalities among the 1970 U. S. population. This combined nuclear striking force would be equivalent to a total of 593 deployed SS-9 missiles with the MIRV system, all armed with 100-kt warheads.

Assuming such an SS-9 MIRV force to be in existence, estimated minimum deployment times and costs in 1970 U. S. dollars for both the total and additional SS-9 missiles (each fitted with 40 100-kt warheads) required to cause stated relative fatality levels among the 1970 U. S. population for the conditions of Table 2 are given in Table 3. The year of final deployment is based on the assumption of both a constant rate of production and one that increases linearly from 50 to 100 missiles per year from 1970 to 1980.

Note that the calculations are based on the 1970 U. S. population distribution; thus, for the fatality percentage having Y_1 and Y_2 values significantly larger than 1970, the number of required missiles, the values of Y_1 and Y_2 , and the added cost are all underestimates (except for the 100% level of fatalities). Since the estimated number of missiles refers to weapons delivered on target, these figures are, by definition, underestimates of force requirements for the stated fatality levels.

These estimates suggest that at the current rate of production the most economical and effective SS-9 MIRV system could not impose, through air-blast weapons effects, the current popular view of assured and complete destruction of the 1970 U. S. population in a nuclear attack until sometime after the year

Table 3

ESTIMATED NUMBER OF SS-9 MISSILES WITH MIRV, YEAR OF FINAL DEPLOYMENT, AND COSTS FOR CAUSING A STATED PERCENTAGE OF FATALITIES AMONG THE 1970 U. S. POPULATION BY BLAST EFFECTS ON PEOPLE IN WOOD-FRAME STRUCTURES

Fatalities, %	Total required number of SS-9 missiles	Additional required number of SS-9 missiles	Y_1^* (year)	Y_2^\dagger (year)	Added cost, 10^9 \$ (U. S., 1970)
20	80				
30	180				
40	340				
50	530				
60	1,060	467	1979	1977	13
70	5,310	4,717	2064	2005	130
80	15,600	15,010	2270	2037	413
90	38,700	38,110	2732	2084	1050
100	115,500	114,900	4268	2175	3200

* $Y_1 = 0.02N_m + 1958$, at a constant rate of 50 SS-9 missiles per year.

† $Y_2 = (0.4N_m - 137)^{1/2} + 1960$, at a rate of 50 (1 + 0.1t) SS-9 missiles per year, where $t = Y_2 - 1970$.

3000. With a constantly increasing rate of production of the missile system, however, the force required for such a level of fatalities might be assembled and deployed in 100 to 200 years. The cost of such a system could be two times the estimated \$3 trillion (1970 dollars); this is about 1000 times the current yearly Gross National Product of the U.S.S.R.

Methods for estimating the intermediate-range fallout from 100-kt-yield weapons detonated as airbursts to give maximum area coverage of a given overpressure contour are not immediately available. Thus the general extent or degree of the radiological hazard to agricultural areas downwind from any of the larger urban centers hit in such an attack cannot be given.

The effects of detonating the 100-kt weapons at ground level were investigated in an alternate assumed attack mode. This alternative is suggested since the fallout levels in the vicinity of ground zero appear to be maximized at a yield of around 100 kt. The areas enclosed by exposure-dose contours of 400 and 1200 R over a period of 100 hr after fallout arrival for 100-kt-yield (100% fission) and 1-Mt-yield (50% fission) surface detonations are shown in Fig. 3. The 400-R contour indicates generally the limiting extent (outer boundary) at which a significant number of persons sheltered in wood-frame houses would experience radiation sickness. The 1200-R contour indicates generally the limiting boundary at which essentially all persons sheltered in wood-frame houses over the specified 100-hr period would eventually die. In other words, all

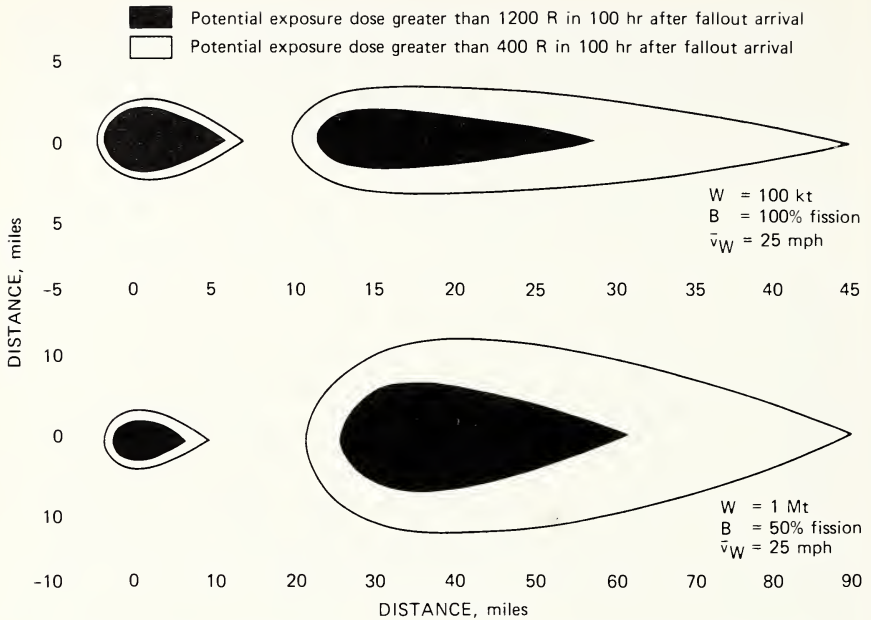

Fig. 3 Area enclosed by exposure-dose contours of 400 and 1200 R for fallout from 100-kt- and 1-Mt-yield surface detonations.

persons in the shaded area of Fig. 3 who were in shelters with a protection factor of 2 (or more at central locations) would become fatalities.

The full significance of the total fallout-radiation hazard within the two elliptically shaped areas, in terms of number of fatalities, cannot be readily incorporated into the described antipopulation attack patterns (in which the only hazard considered was blast overpressure from air detonations) without using a large-scale computer program. However, a conceptual view of the relative hazard to people in small wood-frame structures can be obtained from simple arithmetic estimates if only the circular portion of the potentially lethal area around ground zero is considered. The radius of this area is 1.9 miles for the 100-kt detonation and 2.5 miles for the 1-Mt detonation. Thus the potential lethal radius for the fallout hazard from the 100-kt surface detonation under the assumed exposure conditions is 3.4 times the lethal radius for the overpressure hazard from the 100-kt air burst (the area ratio is almost 12 to 1). In comparison, these radius and area ratios for the 1-Mt detonation are only 2.1 and 4.4, respectively. Another way of stating the relative extent of these two hazards for the specified exposure conditions is that the area coverage of the 100% lethal fallout level from a 100-kt surface burst is equal to that of the overpressure effects from a 4-Mt air detonation.

For people inside concrete buildings with a protection factor of 100, the radius of the 600-R lethal-exposure dose from ground-zero-region fallout from the 100-kt surface detonation is almost 0.5 mile, only slightly larger than the radius of the 48-psi contour (100% lethal for occupants of concrete structures) for the 100-kt air burst. The same relative potential hazard from fallout does not occur for the 1-Mt surface detonation since the absolute magnitudes of the fallout levels near ground zero are smaller in this case; also, the time of fallout arrival is shorter for the smaller-yield detonation.

The general dispersion of ground-zero- and downwind-fallout patterns, as represented by the 1200-R potential-exposure-dose contour, for closepacking of the ground-zero patterns to cover circular-shaped urban areas is illustrated in Figs. 4 and 5. In these figures A_T is the largest inscribed circular area enclosing an urban target area, and A_R is the area within the downwind 1200-R exposure-dose perimeter for fallout from cloud altitudes. Figure 5 shows that A_T for 16 and 28 detonations includes a portion of several cloud-fallout patterns; in addition, the maximum downwind extent of the perimeter of the

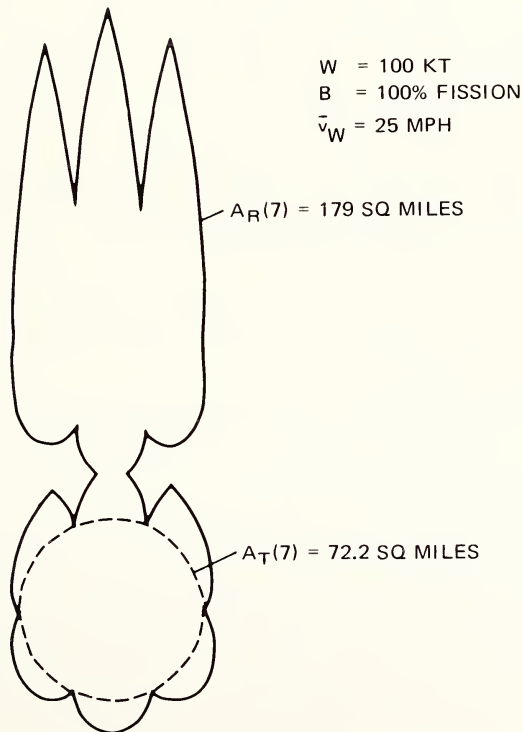

Fig. 4 Geometric configuration of A_T and A_R for the 1200-R exposure-dose perimeter when A_T is equal to the maximum circular area covered by seven overlapping ground-zero fallout patterns.

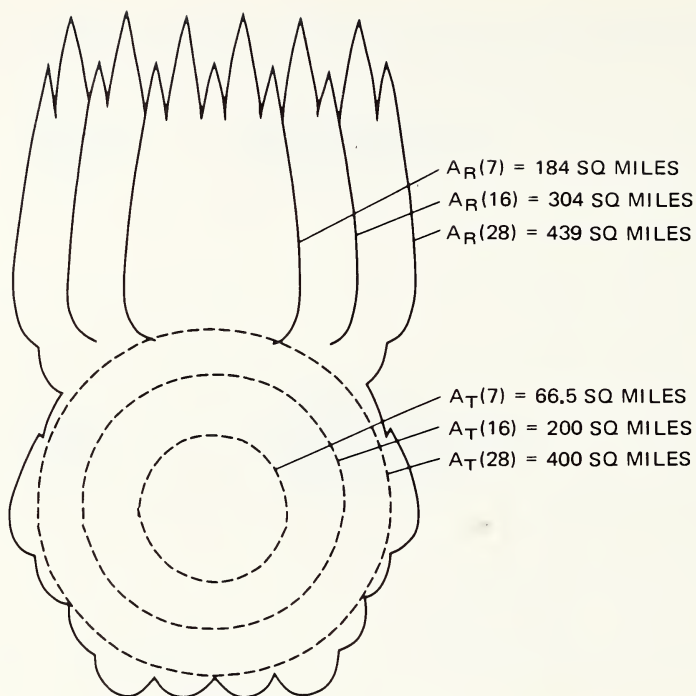

Fig. 5 Geometric configuration of A_T and A_R for the 1200-R exposure-dose perimeter when A_T is equal to the maximum circular area covered by 7, 16, and 28 overlapping ground-zero fallout patterns.

1200-R exposure-dose contours is essentially constant and independent of the size of the circular target.

The average, or midrange, values of A_T and A_R are plotted as a function of the number of weapons detonated (or the number of ground-zero patterns) giving full circular coverage of the target area. No real, single, smooth curve of A_T and/or A_R as a function of the number of detonations or weapons exists for target-area coverage requiring one to seven weapons per target. The curves in Fig. 6 tend to follow midrange values of A_T and A_R ; as the number of weapons per target increases, the percentage spread in possible values of these two parameters decreases. The curves in Fig. 6 were used to estimate the number of weapons per target required to enclose each of the 500 largest U. S. cities or urban places within the 1200-R contour and the relative amount of land area outside the urban areas that would also be enclosed (assuming no overlapping of the fallout patterns from these targets and no loss of fallout to areas outside the country). The calculated cumulative explosive yield of the 100-kt weapons, the total rural land area enclosed, and the number of people involved (i.e., those

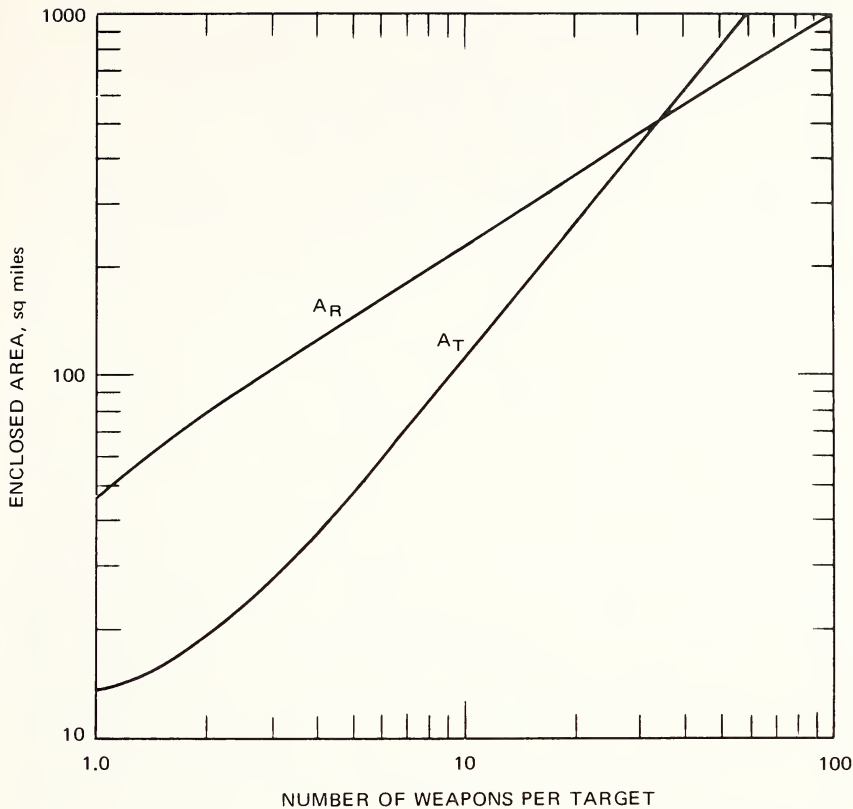

Fig. 6 Variation of A_T and A_R with number of weapons detonated or number of ground-zero fallout patterns.

residing in the area given by A_T who would be fatally involved if sheltered in wood-frame houses) are given in Table 4.

The calculations in Table 4 indicate that, for the 500 most densely populated cities or urban places, coverage of the respective A_T with at least the 1200-R exposure-dose contour could be accomplished with a total explosive yield of about 103 Mt (i.e., 1030 delivered weapons yielding 100 kt each) and that almost 1.0% of the land area of the United States outside the cities would be enclosed within the specified 1200-R exposure-dose contour. As shown, the 500 most densely populated cities or urban places contain about 35% of the 1970 U. S. population; the estimated number of 100-kt airbursts required to cause 35% fatalities by air-blast effects among the population sheltered in wood-frame structures would be about 14,000.

Thus, if the major portion of the U. S. population were in shelters with a protection factor of 2 at the time of attack, the number of SS-9 missiles with an

Table 4
 CUMULATED TOTAL YIELD OF 100-KT SURFACE BURSTS
 TO ENCLOSE THE 50 TO 500 MOST DENSELY POPULATED CITIES
 AND NEARBY RURAL AREAS WITHIN THE 1200-R
 EXPOSURE-DOSE CONTOUR

Target number	M, Mt	AR, sq miles	AR/3.6 × 10 ⁴ , %	Cumulated percent of total population
50	15.2	4,470	0.12	12.8
100	23.3	7,520	0.21	15.9
200	41.5	14,190	0.39	21.4
300	62.3	21,240	0.59	27.1
400	79.0	27,690	0.76	30.4
500	103.4	35,750	0.99	35.0

idealized MIRV system and 100-kt weapons required to cause a given level of fatalities would be about a factor of 13.5 less for an attack in which all explosions are ground bursts instead of airbursts (i.e., if the fallout effect instead of the air-blast effect were used against the population). This result suggests that, without reasonably good fallout protection in the cities, the planned use of surface-detonated 100-kt weapons could reduce the time scale required to construct a force that could assuredly destroy the 1970 U. S. population from about a century or two to about a decade or two (especially if all technical problems of production of such a force would be solved without causing extended delays in deployment).

This rather high relative degree of potential effectiveness of the fallout hazard from the 100-kt surface detonation could, of course, be countered by the provision and use of shelters with protection factors higher than 2. Increasing the protection against the fallout radiation would decrease the lethal radius from fallout radiation. In turn, a larger number of warheads and missiles would be required to accomplish the same level of population destruction by either fallout radiation or air blast. The times for producing the needed force would then be increased beyond the minimum of the decade or two indicated previously. For a shelter protection factor of 130, the 100% lethal radius for the very close-in fallout from a 100-kt true surface burst would be equal to the 100% lethal radius for the population sheltered in concrete buildings subjected to the air-blast overpressure from a 100-kt airburst. In such a protective posture, the limiting force requirements for assured destruction of the 1970 population would be 160,000 SS-9 missiles carrying 100-kt warheads with MIRV's for the smaller targets. Such a force, built at the previously assumed rates which increase continuously with time, could be deployed approximately by the year 2760 at a cost of about \$4.5 trillion (1970 U. S. dollars).

The apparent advantage of the reduction in force requirements gained when lower-yield warheads with MIRV are allocated to small urban places, missile sites, and other military targets, together with the fact that area coverage for the circular prompt weapons-effect contours is independent of weapon yield, could suggest a gradual conversion of existing stockpiled weapons to lower-yield warheads in all nuclear arsenals soon after MIRV capabilities become operational. If this is the case, some major changes in civil-defense policies, programs, and operational plans could be considered to provide an appropriate response to salient features of the revised-force capabilities. Two major options are: (1) the provision of increased protection to the population and to other resources in urban areas against the prompt weapons effects (i.e., blast, thermal, shock, and initial nuclear radiation) and (2) the evacuation of cities when there is sufficient warning time. The first option would include the provision of shelters with a minimum protection factor of 130 to negate the advantage of the 100-kt surface burst. For the second option, some difficulties could occur if ground bursts were used; however, the downwind extent and width of the fallout pattern from the 100-kt surface detonation is much less than that from detonations in the megaton-yield range, as shown in Fig. 3. This associated reduction in fallout areas for attack patterns including only urban-area targets (65% or less of the 1970 population) would leave essentially all the rural areas and the agricultural sector free of direct exposure to any weapons effects. If shelters were available in urban areas, postattack evacuation to rural areas free of fallout would be a feasible operational alternative.

As previously mentioned, exposure doses from fallout radiation near ground zero are greater for detonations with yields close to 100 kt because of the early fallout arrival times and the rather heavy local deposits surrounding the point of detonation. Further insight into these ramifications of the fallout hazard would require a more detailed analysis than that given here; such an analysis could be readily accomplished with the aid of computers. Specific consideration of the people, animals, and plants that could be exposed to radiological hazards from the downwind fallout has been neglected here. However, practically no human fatalities would occur from fallout in the downwind area from the 100-kt surface burst if shelters with a protection factor of 130 were available and were used. In the described antipopulation attacks (similar results would apply to a pure counterforce attack), the downwind boundary of the 1200-R exposure-dose contour extends a distance of 20 to 30 miles from the downwind edge of the urban areas. Thus the size of the rural farm areas receiving moderately heavy fallout levels from the 100-kt surface bursts would be approximately equal to the size of the urban areas subjected to direct attacks. Consequently agricultural problems caused by fallout would be limited to regions near target cities or target military installations. This pattern would persist until more than about 65% of the population (all urban places) was involved. For much heavier attacks, with 100-kt-yield ground-burst weapons, however, the radiological effects on

agriculture could approach those predicted for the counterforce and mixed attacks using larger-yield weapons.

SUMMARY AND CONCLUSIONS

The intrinsic properties of fallout associated with radiological hazards which could affect agricultural operations in the postattack period of a nuclear war include: (1) the radionuclide composition of the fallout material, which determines the energy composition of the gamma and beta radiation emitted, (2) the physical and chemical properties of the fallout particles (such as size, shape, composition, structure, and solubility) which influence their retention by surfaces, and (3) the solubility and biological availability of specific radionuclides. In terms of crop or agricultural-product output, both operational factors (effects on man and his social system) and biological factors (response of plants, animals, birds, and insects) would be important.

The degree of the hazard to the food-producing agricultural systems would generally depend more on external parameters, such as the available weapon system, form or mode of attack, level of attack, explosive yield of weapons, relative heights of burst, and local and regional weather patterns, than on the properties of the fallout. The latter would tend to influence the form rather than the degree of the hazard.

A major recent development in weapon systems that could have a significant impact on the type and extent of hazard to agriculture in a nuclear war is the Multiple Independent Targeted Reentry Vehicle. Indeed, estimates of MIRV system capabilities, especially in terms of using many smaller-yield warheads on many smaller targets, may be used to identify several important implications for future civil-defense planning. One estimate involves the relatively high levels of the fallout hazard near ground zero, which apparently has a maximum for a surface detonation at a yield of about 100 kt. The implication of this effect on weapon-system cost and times of deployment for the Soviet Union and its SS-9 missile system is that, if the U. S. fallout-shelter system were poor and a majority of people had to remain in their houses during an attack, the Soviets could build and deploy at a cost of about \$30 billion within the next 10 to 20 years a nuclear force of sufficient capability to essentially assure the destruction of the entire U. S. population. In this case "sufficient capability" refers to the use of the force in an antipopulation attack in which local fallout would be the main cause of fatalities. On the other hand, if fallout shelters with protection factors of 130 or more were available and were used, no advantage in force requirements would accrue by the use of surface bursts. Instead, the more reliable overpressure effects would be used. In the limit, the assured destruction of the U. S. population by blast effects would require at least 160,000 SS-9 missiles. Even at reasonable increases in production rates, the Soviets would have difficulty in deploying such a force within the next 800 years (using currently

available technologies); the cost of such a force would be prohibitive at more than \$4.5 trillion (1970 U. S. dollars).

The major implication for agricultural systems of the possible use of MIRV and the associated lower-yield warheads in a nuclear war is that the fallout would be of the intermediate or worldwide type for attacks in which air-blast effects are emphasized and that, where the fallout effects are emphasized by use of ground bursts, the heavy downwind deposits of local fallout would be limited to a distance of about 30 miles from the downwind edge of any target independent of the size of the target. In other words, the effect of MIRV and the associated lower-yield warheads would be to almost eliminate the widespread fallout effects previously estimated for attacks in which land-surface detonations of weapons in the megaton-yield range have been postulated. With the described Soviet SS-9 missile system with MIRV capabilities, a comparable degree of effect on agriculture might be achieved from attacks designed to kill more people than the entire U. S. urban population (i.e., more than 65% of the 1970 U. S. population) in which all detonations programmed for the rural areas would be surface bursts. Further detailed calculations are required before the potential of such an attack to cause significant adverse effects on agriculture can be evaluated, given the current public fallout-shelter system as a basis for estimating population survival.

REFERENCES

1. C. F. Miller and P. D. LaRiviere, Introduction to Longer-Term Biological Effects of Nuclear War, SRI Project IMU-5779, Stanford Research Institute, 1966.
2. R. B. Platt, Ecological Effects of Ionizing Radiation on Organisms, Communities, and Ecosystems, in *Radioecology*, Reinhold Publishing Corporation, New York, 1963.
3. C. F. Miller, Fallout and Radiological Countermeasures, Vols. I and II, SRI Project IMU-4021, Stanford Research Institute, 1963.
4. K. H. Larson and J. W. Neel, Summary Statement of Findings Related to the Distribution, Characteristics, and Biological Availability of Fallout Debris Originating from Testing Programs at the Nevada Test Site, USAEC Report UCLA-438, University of California, Los Angeles, Sept. 14, 1960.
5. J. P. Friend, H. W. Feely, P. W. Krey, J. Spar, and A. Walton, The High Altitude Sampling Program, Report DASA-1300 (Vols. 1, 2A, 2B, 3, 4, and 5), Defense Atomic Support Agency, Aug. 31, 1961.
6. C. F. Miller, Operation Ceniza-Arena: The Retention of Fallout Particles from Volcán Irazú (Costa Rica) by Plants and People, Parts Two and Three, SRI Project IMU-4890, Stanford Research Institute, 1967.
7. National Academy of Sciences—National Research Council, Damage to Livestock from Radioactive Fallout in Event of Nuclear War, Publication No. 1078, Washington, D. C., 1963.
8. National Committee on Radiation Protection and Measurements, Exposure to Radiation in an Emergency, Report No. 29, 1962.
9. J. L. Mackin, S. L. Brown, and W. B. Lane, Beta Radiation Dosimetry for Fallout Exposure Estimates: Comparison of Theory and Experiment, SRI Project 7402, Stanford Research Institute, 1969.

10. S. L. Brown, Disintegration Rate Multipliers in Beta-Emitter Dose Calculations, SRI Project IMU-5116, Stanford Research Institute, 1965.
11. J. D. Teresi and C. L. Newcombe, An Estimate of the Effects of Fallout Beta Radiation on Insects and Associated Invertebrates, Report AD-633024, Naval Radiological Defense Laboratory, Feb. 28, 1966.
12. Report of ICRP Committee on Permissible Dose for Internal Radiation (1959), *J. Health Phys.*, 3 (1960).
13. J. L. Kulp and A. R. Schulert, Strontium-90 in Man and His Environment, USAEC Report NYO-9934 (Vols. I, II, and III), Columbia University, 1961 and 1962; also R. S. Hirschman and A. R. Schulert, Strontium-90 Assay of Various Environmental Materials, USAEC Report NYO-9934 (Vol. III) Ext., Columbia University, 1961.
14. C. F. Miller and S. L. Brown, Models for Estimating the Absorbed Dose from Assimilation of Radionuclides in Body Organs of Humans, SRI Project IMU-4021, Stanford Research Institute, 1963.
15. C. F. Miller, Assessment of Nuclear Weapon Requirements for Assured Destruction, URSRC Report 757-6, URS Research Company, 1970.
16. R. K. Laurino, National Entity Survival Following Nuclear Attack, SRI Project IN-OAP-28, Stanford Research Institute, 1967.
17. William Beecher, Soviet Arms Gain Detected by U. S., *New York Times*, 1969.
18. Ashley W. Oughterson and Shields Warren, *Medical Effects of the Atomic Bomb in Japan*, Division VIII, Vol. 8, National Nuclear Energy Series, McGraw-Hill Book Company, Inc., New York, 1956.
19. Raisuke Sirake, Medical Survey of Atomic Bomb Casualties, Research on the Effects and Influences of the Nuclear Bomb Test Explosives, Volume II, Japan Society for the Promotion of Science, Tokyo, 1956.
20. C. F. Miller, Protection of People by Structures from the Initial Radiation, Blast, and Thermal Phenomena of Nuclear Explosives, Research Report No. 7, Office of Civil Defense, Department of Defense, 1962.

PREPARATION AND USE OF FALLOUT SIMULANTS IN BIOLOGICAL EXPERIMENTS

WILLIAM B. LANE

Stanford Research Institute, Menlo Park, California

ABSTRACT

Facilities developed by the Office of Civil Defense for the production of synthetic fallout are described. The capability for simulating nuclear fallout is reported and is exemplified by a description of the production (1) of a 300-lb batch of synthetic fallout tagged with 15 Ci of ^{137}Cs and (2) a small routine batch of synthetic fallout tagged with ^{90}Y , which is produced once or twice a month.

The nuclear weapons test-ban treaty, which effectively prohibits the detonation of nuclear weapons in the atmosphere, has made necessary the development of alternative experimental techniques for obtaining data on the interaction of radioactive fallout with the environment. Procedures for preparing synthetic fallout that simulates some of the important properties of fallout generated by nuclear weapons have been developed over the past few years. Synthetic radioactive fallout can be employed in many experimental programs directed toward obtaining operational and technical data used to develop plans for survival and recovery measures during and after a nuclear war.

Procedures developed to simulate many properties of real fallout¹⁻³ have been used in the hot-cell facility at Camp Parks to prepare batches of synthetic fallout for studies sponsored by the Office of Civil Defense. Investigators at the U. S. Naval Radiological Defense Laboratory (USNRDL), Cornell University, Oak Ridge National Laboratory (ORNL), University of Tennessee, University of California, Lawrence Radiation Laboratory, Colorado State University, University of North Carolina, and Stanford Research Institute all have used synthetic fallout prepared to their specifications.

Stanford Research Institute now operates the Camp Parks hot cell for the Office of Civil Defense.

SYNTHETIC-FALLOUT PRODUCTION PROCESS

The steps in producing synthetic fallout include: (1) mineral processing to produce sized particles in ton quantities, (2) radioisotope processing in the hot cells, (3) radiotagging the mineral particles in concrete mixers and high-temperature furnaces, and (4) testing and control to ensure the radiochemical, chemical, and physical properties of the synthetic fallout.

Mineral Processing

Radioactive particles from 44 to 700 μ in diameter comprise a very large fraction of local fallout from a land-surface nuclear detonation. Four particle-size groups—44 to 88, 88 to 175, 175 to 350, and 350 to 700 μ —are produced to cover the range.

Carload lots of feldspar, quartz, and clay, the principal minerals in the earth's crust, were purchased. Some required crushing and pulverizing, but most were in the form of sand and required only sieving to produce the full range of particle sizes.

The particles were separated into sized groups on a commercial sieving machine manufactured by Novo Corp. A wet centrifugal method was used to remove fine particles from the 44- to 88- μ material. Sieving efficiency was measured and controlled by frequent determinations of particle size made with Tyler sieves and a Ro-Tap machine. Each of the size groups was produced in ton quantities and stored in color-coded bags and barrels. If extremely clean cuts were required, pound lots of these stored particles were further processed on the Ro-Tap by wet sieving.

Some important physical properties of the four particle-size groups of Wedron sand were measured by careful sieving into a large number of intermediate sizes. The data permitted calculations of the properties as shown in Table 1.

Table 1
PHYSICAL PROPERTIES OF WEDRON SAND

Group, μ	Number of particles per gram	Average surface area per particle, cm^2	Average particle diameter, μ
44 to 88	6.98×10^6	6.69×10^{-5}	47
88 to 175	6.20×10^5	3.21×10^{-4}	101
175 to 350	7.54×10^4	1.39×10^{-3}	210
350 to 750	7.09×10^2	7.85×10^{-3}	500

Radioisotope Processing

Two hot cells are provided for radioisotope handling. Each cell has an inside floor area 8 by 8 ft. Shielding is provided by 2-ft-thick concrete walls, and there is a 2-ft-thick zinc bromide-filled viewing window.⁴ One cell is fitted with a pair of model 8 Hevi-Duty Master-Slave manipulators and the other cell with a pair of model 4 manipulators. Ventilation is provided by blowers that maintain a slight negative pressure inside the cells. Leakage air, amounting to about 500 cfm, is exhausted through absolute filter banks. A $\frac{1}{2}$ -ton monorail hoist provides access to the cells and to a shielded alleyway. One cell is equipped with a $\frac{1}{4}$ -ton jib crane that remains inside the enclosure. Each cell has through-wall holes for sample removal and for pressure, vacuum, and water lines. Each cell is supplied with a 100-amp three-phase four-wire electrical service. Work tables consist of stainless-steel trays atop cubic-yard concrete blocks that are carried on warehouse dollies. A 15-gal drum is cast into the center of the concrete block to serve as a receptacle for waste disposal. Separate work tables set up for specific operations are wheeled into the hot cell as needed.

Solid waste is collected in polyethylene-lined drums and then transferred to approved shipping boxes. Liquid waste is poured into 5-gal polyethylene carboys and then solidified with Micro-Cell E (a Johns-Manville product). Ultimate disposal is contracted to a licensed company such as Nuclear Engineering of Walnut Creek, Calif.

Radioisotopes that have been processed include kilocuries of ^{140}Ba , ^{140}La , ^{147}Pm , and ^{204}Tl ; multicuries of ^{85}Sr , ^{90}Sr , ^{95}Zr , ^{95}Nb , ^{103}Ru , ^{106}Ru , ^{131}I , ^{137}Cs , ^{144}Ce , ^{177}Lu , and ^{198}Au ; millicuries of ^{85}Rb and ^{134}Cs ; and gross fission product.

Many of these radioisotopes have been produced by neutron irradiation in the nearby General Electric Company test reactor at Vallecitos. Tools and equipment for encapsulating, testing, and opening the irradiated capsules are available in the hot cells.

Radiotagging Mineral Particles

Radiotagging consists in spraying a weak acid solution of a selected radioisotope on a charge of mineral particles as they are tumbling in a rotating mixer. The particles are then dried by the direct application of heat or by introduction of heated air to the mixer. Subsequent treatment determines the solubility or availability of the radioisotope.

A nonleaching synthetic fallout is produced by "fixing" the radioisotope with an overcoat of sodium silicate. This is accomplished by spraying a solution of sodium silicate on the dry radiotagged particles while they are still in the mixer; after this spraying they are again dried. The amount of sodium silicate is adjusted to produce a layer less than 1μ thick. Tagged particles are then removed from the mixer and placed in a furnace at 2000°F to fuse the sodium

silicate layer and seal in the radionuclide. The physical properties of the mineral particles are not appreciably altered by this treatment. However, in many cases a realistic and specified solubility of the radionuclide is desired. This is accomplished by heating the radiotagged mineral particles (without sodium silicate) to previously determined temperatures that alter the particle surface and control the combined chemisorption and diffusion of the radionuclide in the particle matrix.

The batch size of mineral particles dictates which of the available rotating mixers is selected for a particular operation. Ball mills and twin-shell blenders are used for gram and pound lots. Portable 1-cu-ft concrete mixers are used for lots of up to 100 lb. Specially modified 2-yd concrete mixers are used for 500-lb batches. The latter are charged with mineral particles by lift truck and hoppers. The radioisotope is sprayed on, the particles are dried, the sodium silicate is sprayed on, and the particles are dried again; the synthetic fallout is then discharged on an endless belt that conveys it to a bucket elevator and a metering hopper where it is placed in stainless-steel pans. The pans are pushed by hydraulic ram along skid rails into a gas-fired furnace. After spending an hour in the furnace at 2000°F, the pans are pushed out the other end of the furnace where the synthetic fallout cools. Further pushing automatically dumps the pans and discharges the cooled synthetic fallout on to another endless belt for transfer to shielded hoppers. All these operations are performed from a remote and shielded location to minimize the radiation dose to personnel.

Several electric furnaces are available for heating gram and pound lots of synthetic fallout. A large number of lead and concrete containers are available to meet a wide range of volume and shielding requirements.

Testing and Control of Synthetic Fallout

Radiation-measuring equipment for analytical purposes consists of a 4-pi ionization chamber, a gamma spectrometer, a scintillation crystal counter, and a Geiger counter.

1. The 4-pi ionization chamber is used to assay all incoming shipments of radioisotopes and all outgoing batches of synthetic fallout. Over the years it has proved to be a reliable instrument, and the results obtained with it are considered very accurate.

The 4-pi ionization chamber is filled with argon to 600 psig at 70°F. The cylindrical steel chamber is 11 in. in diameter and 14 in. high and has a reentrant sample thimble 1 $\frac{3}{4}$ in. in internal diameter by 12 in. deep. The entire chamber is shielded by 3 in. of lead. Current produced in the chamber by ionizing radiation is applied to suitable load resistors; the resulting voltage drop drives a plate-difference amplifier and is read out on a microammeter. The useful ionization current ranges between 4×10^{-10} and 3×10^{-5} ma. All readings are normalized to a standard response of 5.60×10^{-7} ma for 100 μ g of radium. The

response (milliamperes per disintegration per second) of many radioisotopes has been accurately determined.⁵

2. The gamma spectrometer is used to verify the radiochemical purity of all incoming radioisotopes and all outgoing batches of synthetic fallout. It is composed of a pulse-height analyzer, a paper-tape printer, and an X-Y plotter. The Technical Measurement Corp. (TMC) Gammascop analyzes signals whose pulse height is proportional to photon energy and sorts the signals into one of 100 channels, depending on their peak amplitude. The accumulated data are presented on a display oscilloscope and then read out on a TMC paper-tape printer or a Moseley X-Y plotter.

3. The scintillation counter consists of a 3- by 3-in. sodium iodide crystal with a 1 $\frac{1}{4}$ - by 2-in. deep well mounted on an E&M Instruments Co., Inc., 3-in. photomultiplier tube whose output is fed directly into a Systron model 1091-3 scaler. The scaler is controlled by a Nuclear Dual Timer. A John Fluke Manufacturing Company, Inc., model 412A high-voltage power supply provides dynode string voltage for the photomultiplier tube. Shielding consists of a lead cylinder 3 in. thick, 9 in. in internal diameter, and 22 in. high. A 2-in.-thick lead cover moves in and out to permit sample access to the well crystal.

4. A Geiger counter consisting of a thin-walled Geiger tube and a Berkeley scaler measures activity on filter papers that are used to collect air samples or to swipe floors or bench tops.

Instruments for radiation safety and contamination control consist of 1-cfm constant-flow air samplers, El-Tronics, Inc., CP30 meters (Cutie Pie), and Nuclear Electronics XX2 survey instruments.

SYNTHETIC-FALLOUT PRODUCTION

Synthetic-fallout production can be illustrated and the capability exemplified by reporting on two production batches.

Cesium-137 Tagged Synthetic Fallout

Investigators at ORNL requested a synthetic fallout for an ecological study they were conducting for the Office of Civil Defense. The study measured effects of ^{137}Cs on a controlled ecological system over a period of years.

Three hundred pounds of 88- to 175- μ sand was tagged with ^{137}Cs in a 1-cu-ft mixer in two batches. The first batch of 140 lb had a specific activity of 36.6 mCi/lb, and the other batch of 160 lb had a specific activity of 46.7 mCi/lb. All the tagged sand was heated to 900°C and held at that temperature for 2 hr. The resulting synthetic fallout was leached overnight by 0.1N HCl. Overnight leaching of 2-g samples of the resulting synthetic fallout by 20 ml of 0.1N HCl removed 21% of the ^{137}Cs activity.

Since the ORNL study was designed to continue for several years, leaching data covering a few hours seemed inadequate to predict the availability of cesium. Accordingly, long-term tests were initiated to measure the leaching of cesium at extreme dilutions. This was accomplished by setting aside the 20-ml aliquot of 0.1N HCl that resulted from overnight leaching and adding a second, similar aliquot to the once-leached synthetic fallout. This process of leaching the same mineral fraction for random time intervals with fresh aliquots was continued for 1250 days and resulted in the accumulation of 28 successive leaching aliquots.

The mechanism for the first 10 days of leaching appeared to be a chemisorption process that was well described by a Freundlich adsorption equation of the form

$$C_m = kC_l^n \quad (1)$$

where C_m is the average cesium concentration in the mineral particles and C_l is the concentration in the leaching solution.

It appeared that the longer-term leaching behavior (from 10 days to more than 3 years) was described by a diffusion-limiting mechanism corresponding to the solution of Frick's law for diffusion from a sphere:

$$\frac{C_m}{C_0} = \frac{6}{\pi^2} \sum_{\nu=1}^{\infty} \frac{1}{2} \exp(-\nu^2 \pi^2 Dt/r_0^2) \quad (2)$$

When t is sufficiently large, the first term of the series is a good approximation, so that

$$\frac{C_m}{C_0} \approx \frac{6}{\pi^2} \exp\left(-\frac{t}{\tau}\right) \quad (3)$$

where

$$\tau = \frac{r_0^2}{\pi^2 D}$$

C_0 = initial average cesium concentration in the mineral

C_m = concentration after various leaching times

t = time of leaching

r_0 = radius of the fallout particle

D = diffusion coefficient

In this approach the leaching of radionuclides from fallout particles for long periods of time can be predicted if the numerical values of k , n , and D in Eqs. 1 and 2 are known.

Monthly Batch of Multicurie ^{90}Y Tagged Synthetic Fallout

A 250-mCi ^{90}Sr "cow" was started in a lead-shielded Berkeley glove box about 3 years ago to supply ^{90}Y for a study of beta effects on beans. To satisfy requirements for several OCD studies, the activity level was soon raised to 30 Ci. This was accomplished by wheeling the shielded box inside one of the two hot cells to ensure double containment and simply adding 30 Ci of carrier-free ^{90}Sr to the 400-ml beaker that already contained 250 mCi and 2 g of inactive strontium nitrate.

Yttrium-90 is "milked" from the equilibrium mixture by taking the dry strontium nitrate up in 25 ml of distilled water. Strontium nitrate is then precipitated by adding 125 ml of 90% nitric acid. The acid solution containing the ^{90}Y is removed through a filter frit by suction and transferred to the second hot cell where it is evaporated to dryness. The carrier-free ^{90}Y is taken up in 25 ml of water, and 2 g of inactive strontium nitrate is added and precipitated with 125 ml of 90% nitric acid. The acid solution of ^{90}Y is again filtered off, evaporated to dryness, and taken up in 100 ml of 0.1N HNO_3 . About 20 Ci of ^{90}Y are usually available at this point. A 100- μl aliquot of this solution is assayed in the 4-pi ionization chamber to determine the volume required for tagging the particular batch of sand. In the meantime, the ^{90}Sr cow in the Berkeley box is slowly evaporated to dryness and taken up in 25 ml of water to make ready for the next milking.

Sufficient Wedron sand to meet the batch requirements is prepared by wet sieving and Ro-tapping to ensure that all particles are within the specified size range. The sand (up to 600 g) is added to the rotating drum of a ball mill that is operating inside the second hot cell, and the calculated volume of carrier-free ^{90}Y solution is sprayed on the tumbling particles. The radiotagged sand is dried by the heat from a hot plate placed directly under the metal drum, after which 10 ml of sodium silicate is sprayed into the rotating drum to overcoat the particles. After the particles are again dried, the synthetic fallout is transferred to a crucible and placed in a muffle furnace at 1950°F for 1 hr. The synthetic fallout is removed from the furnace, cooled, and returned to the hot cell for assay. When it is determined that the specific activity is within acceptable limits, the synthetic fallout is packaged and shipped.

The ^{90}Sr cow has been milked 25 times for the University of California, 22 times for the University of Tennessee, and 13 times for studies at Stanford Research Institute.

ACKNOWLEDGMENT

This work was done by Stanford Research Institute under Office of Civil Defense Work Unit 3211C.

REFERENCES

1. William B. Lane, Fallout Simulant Development: The Sorption Reactions of Cerium, Cesium, Ruthenium, Strontium, and Zirconium-Niobium, Project No. MU-5068, Stanford Research Institute, November 1965.
2. William B. Lane, Fallout Simulant Development: Temperature Effects on the Sorption Reactions of Cesium on Feldspar, Clay, and Quartz, Project No. MU-6014, Stanford Research Institute, March 1967.
3. William B. Lane, Fallout Simulant Development: Temperature Effects on the Sorption Reactions of Strontium on Feldspar, Clay, and Quartz, Project No. MU-6503, Stanford Research Institute, March 1968.
4. William B. Lane, Argon Improves ZnBr₂ Shielding Windows, *Nucleonics*, **22**: 88-89 (February 1964).
5. Carl F. Miller, Response Curves for USNRDL 4-pi Ionization Chamber, Report USNRDL-TR-155, Naval Radiological Defense Laboratory, May 1957.

FATE OF FALLOUT INGESTED BY DAIRY COWS

G. D. POTTER, G. M. VATTUONE, and D. R. McINTYRE
Lawrence Radiation Laboratory, Bio-Medical Division, University of California,
Livermore, California

ABSTRACT

The fate of fallout ingested by dairy cows—its retention, absorption from the gut, deposition in tissues, and transport to man—is of direct concern when we consider survival of livestock and ingestion of their by-products by man in the event of a nuclear war. The data presented here are from two cows fed debris from a nuclear cratering event. The first of these was given a single dose of debris, and the second received a daily administration of debris. The gamma-emitting radionuclides observed in milk were ^{131}I , ^{132}Te , ^{140}Ba , ^{181}W , ^{187}W , and ^{188}W – ^{188}Re , and in urine, ^{74}As , ^{103}Ru , ^{131}I , ^{132}Te , ^{181}W , ^{187}W , and ^{188}W – ^{188}Re .

Maternal and fetal tissues in the second cow were analyzed for gamma-emitting radionuclides and compared with the maternal plasma levels of these nuclides. Maternal kidney, liver, and spleen concentrated ^{74}As , but fetal tissues had none. Both maternal and fetal thyroids concentrated ^{131}I by 10^5 over maternal plasma. Fetal bone was the primary target organ for ^{140}Ba . The radiotungstens were concentrated by fetal bone and by maternal kidney, liver, spleen, and bone. Elimination patterns of the nonabsorbed radionuclides from debris are also presented.

The fate of fallout ingested by livestock—its retention, absorption from the gut, deposition in tissues, elimination in urine or feces, and transport to man via meat and milk—is of direct concern when we consider the survival of livestock in the event of a nuclear war or the hazard related to ingestion of food products derived from contaminated livestock. Probably the most damaging effects from the ingestion of large amounts of fallout by animals are the early effects of radiation damage and their sequelae leading to radiation sickness and subsequent death. If livestock survive these initial insults, then their suitability as sources of food for man becomes important in long-range considerations.

In recent years the only debris from actual nuclear tests which has been available for study has come from the Plowshare nuclear cratering program. Our

studies are concerned primarily with the biological availability of debris radionuclides from a specific Plowshare nuclear cratering experiment, the Schooner event. This most recent Plowshare nuclear cratering experiment consisted of a 31-kt nuclear detonation executed on Dec. 8, 1968, at the Nevada Test Site. Debris from this event was administered orally to a lactating cow and to a near-term pregnant cow for maternal-fetal transfer studies. These experiments deal primarily with the distribution of gamma-emitting radionuclides in the dairy cow fed debris from this event.

METHODS

Debris from the base-surge area of the Schooner event was collected in fallout trays or in a cyclone-type separator. In both cases the debris consisted of fine dust particles that passed through an 88- μ sieve. One hundred ninety-two grams of the debris from the tray were fed to a lactating cow in 1½-oz gelatin veterinary capsules administered with a balling gun. The animals were catheterized and maintained in metabolic stalls to facilitate collection of urine and feces. Samples of feces, urine, and milk for each 24-hr collection period were pooled and mixed in order to obtain homogeneous samples for counting. Heparinized blood samples were taken following each morning's milking. Samples consisting of 200 g of each of the metabolic products were placed in aluminum tuna cans with formalin added as a preservative and were sealed for counting.

In the second experiment, the maternal-fetal transfer study, 895 g of debris from the cyclone collector was divided into four equal daily doses and administered to a near-term pregnant cow in the same manner. Smaller tissues were minced and suspended in a 2% agar solution in order to ensure constant counting geometry.

All samples were counted on a solid-state germanium-lithium [Ge(Li)] drifted detector using a 2048-channel analyzer (gain = 1.0 keV/channel). The high resolution of these Ge(Li) systems has made them extremely useful for the analysis of complex mixtures of gamma-emitting radionuclides. The resulting gamma-ray spectra were recorded on magnetic tape and analyzed by using a computer code to quantitate the area under each of the gamma peaks, which were then listed in order by energies. The peaks of interest for specific radioisotopes were then selected and processed with a second code, which corrected for physical decay and subsequently calculated the activity per unit weight, the recovery as a fraction of the administered dose for each collection, and the fraction of the administered dose per unit weight of each sample. In addition, this code also plotted the recovery of milk, urine, feces, and plasma as a percent of the administered dose per kilogram vs. time after administration.

RESULTS AND DISCUSSION

Experiment I: Single Administration of Debris

Table 1 shows the nuclides recovered in milk, urine, and feces of the cow following a single oral administration of 92 g of early (5 days postshot) Schooner debris from fallout trays. Arsenic, ruthenium, iodine, tellurium, barium, tungsten, and rhenium were recovered in milk and/or urine. Manganese, cobalt, yttrium, zirconium, gold, and lead were observed only in feces or were in

Table 1
RADIONUCLIDES IN FECES, URINE, AND MILK
FOLLOWING ORAL ADMINISTRATION OF
SCHOONER DEBRIS TO A LACTATING COW

Nuclide	Administered dose, %		
	Feces	Urine	Milk
^{54}Mn	98.99	ND*	ND
^{58}Co	109.9	ND	ND
^{74}As	50.8	29.9	ND
^{88}Y	78.9	ND	ND
^{89}Zr	71.0	ND	ND
^{103}Ru	91.4	7.06	ND
^{131}I	46.4	35.9	2.23
^{132}Te	87.4	1.28	0.07
$^{140}\text{Ba}-^{140}\text{La}$	93.4	ND	0.05
^{181}W	60.1	9.6	0.31
^{187}W	82.4	8.8	0.18
$^{188}\text{W}-^{188}\text{Re}$	80.4	34.8	0.43
^{196}Au	97.6	ND	ND
^{203}Pb	96.4	ND	ND

*The abbreviation ND, no data, indicates amounts too low for quantitation.

levels too low to quantitate in milk or urine. The total amounts of individual radionuclides in the debris were relatively low compared with those of the radiotungstens, which were at least two to three orders of magnitude greater than any of the other radionuclides present. Although ^{196}Au was not observed in milk or urine, it was observed in plasma. The recovery of ^{188}W was greater than 100%. This anomaly is due to the fact that the 155-keV peak of ^{188}Re was used to measure the ^{188}W . The ^{188}Re ($T_{1/2} = 16.8$ hr), the daughter of ^{188}W ($T_{1/2} = 69$ days), was in equilibrium in the debris at the time of administration, and, since the samples were counted shortly after collection, both the ^{188}Re in the debris and the ^{188}Re derived from ^{188}W are present in them. Rhenium is

very rapidly absorbed from the gut, probably directly in the rumen, and is very rapidly excreted, especially in urine and milk, as observed in single isotope experiments. Therefore, since the first two collections of urine and milk reflect rhenium absorption and excretion in addition to the ^{188}W absorption and excretion, a high recovery results.

Figure 1 shows a typical fecal excretion curve for a nonabsorbed nuclide, ^{88}Y . Figure 2 shows the curves for a readily absorbed nuclide, ^{131}I , in feces, urine, milk, and plasma. The curves for urinary and fecal excretion of ^{131}I are quite similar. The levels in milk initially exceed those in plasma but fall more

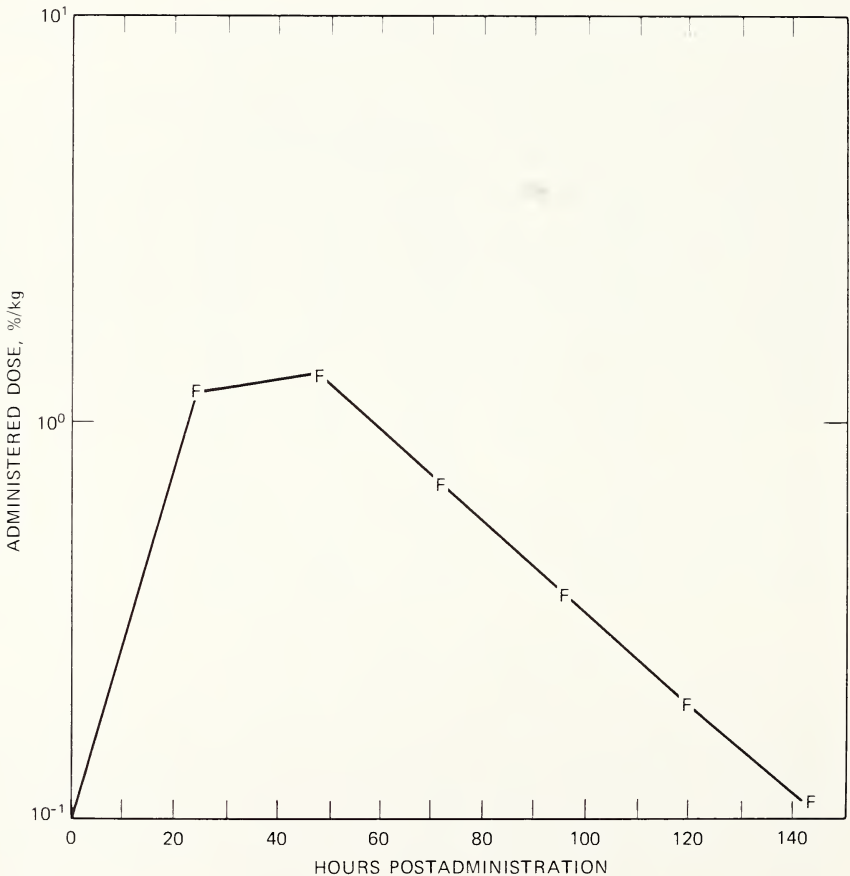

Fig. 1 Typical fecal excretion curve for a nonabsorbed radionuclide (^{88}Y) following a single oral administration of Schooner debris. Concentrations in milk, urine, and plasma are too low for quantitation or are not detected. Fecal curves for ^{57}Co , ^{88}Y , ^{95}Zr — ^{95}Nb , ^{103}Ru , $^{110\text{m}}\text{Ag}$, ^{140}Ba — ^{140}La , ^{141}Ce , ^{182}Ta , ^{196}Au , and ^{203}Pb were almost identical.

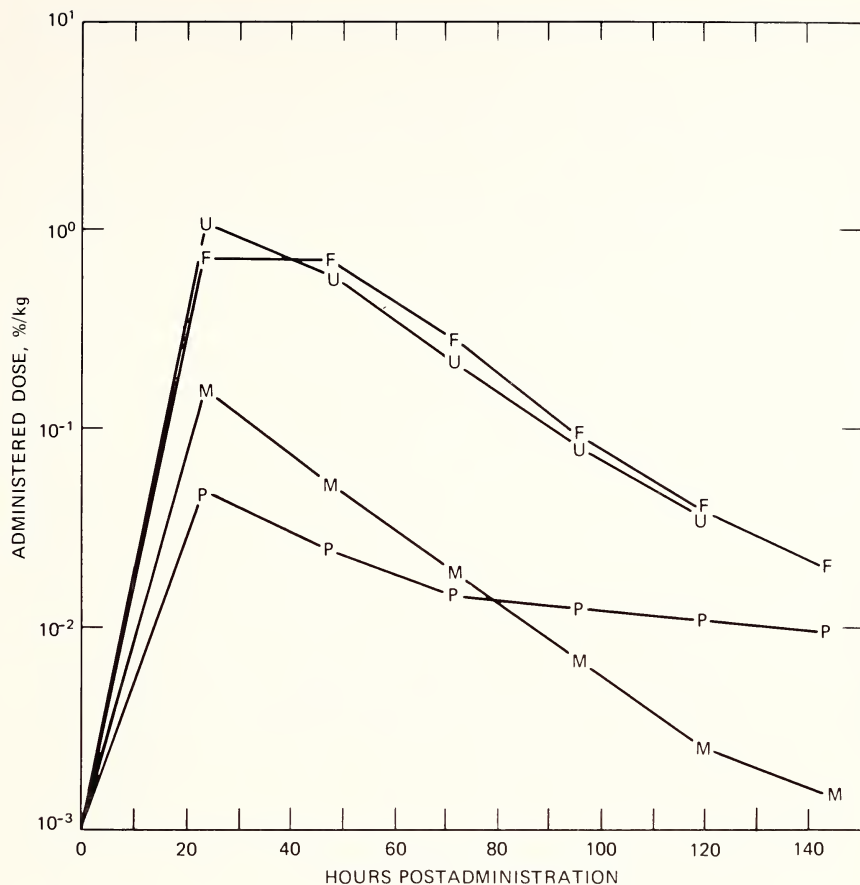

Fig. 2 Uptake and disappearance curves for ^{131}I in feces (F), urine (U), milk (M), and plasma (P) following a single oral administration of Schooner debris.

rapidly since inorganic iodine is secreted in milk, whereas the plasma level reflects, in addition, the presence of organic or protein-bound iodine as well as recycled iodine.

Experiment II: Repeated Administration of Debris and Maternal-Fetal Transfer

A near-term pregnant cow was fed 895 g of Schooner debris from the cyclone collector. This debris, recovered 6 weeks after the detonation, consisted of particles less than $88\ \mu$, the bulk of which were between 20 and $50\ \mu$. The debris was administered in four equal daily doses. The procedure was the same as

in the previous experiment except that at 144 hr the cow was anesthetized and exsanguinated and maternal and fetal tissues were removed for counting.

Figure 3 shows the fecal excretion curve for ^{88}Y , which is typical of nuclides that were not appreciably absorbed from the gut. These included ^{54}Mn , ^{57}Co , ^{88}Y , ^{89}Zr , ^{103}Ru , $^{110\text{m}}\text{Ag}$, ^{140}Ba – ^{140}La , ^{141}Ce , ^{182}Ta , and ^{196}Au .

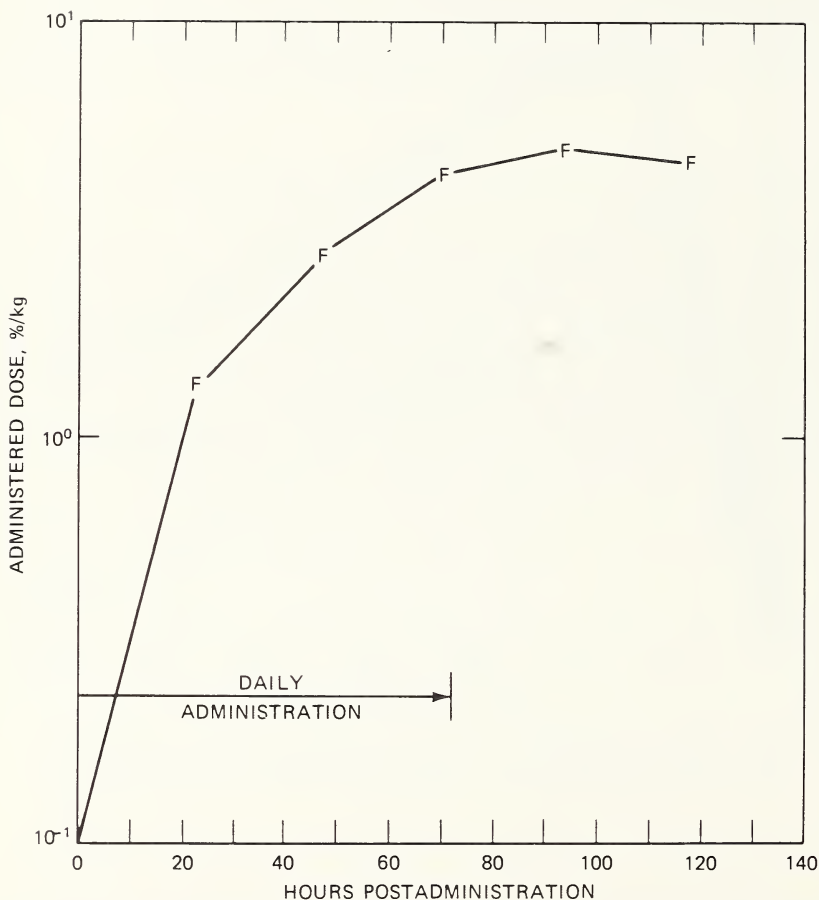

Fig. 3 Typical fecal excretion curve for a nonabsorbed radionuclide (^{88}Y) following repeated daily doses of Schooner debris.

On the other hand, curves for nuclides that are readily absorbed differ in that part of the activity is recovered in milk and/or urine (See Fig. 4). Examples of these nuclides are ^{74}As , ^{131}I , ^{181}W , ^{188}W – ^{188}Re , and ^{184}Re . Of these, ^{74}As was not observed in milk and ^{184}Re was not observed in feces; similar results were obtained in our studies of cows given single carrier-free isotope

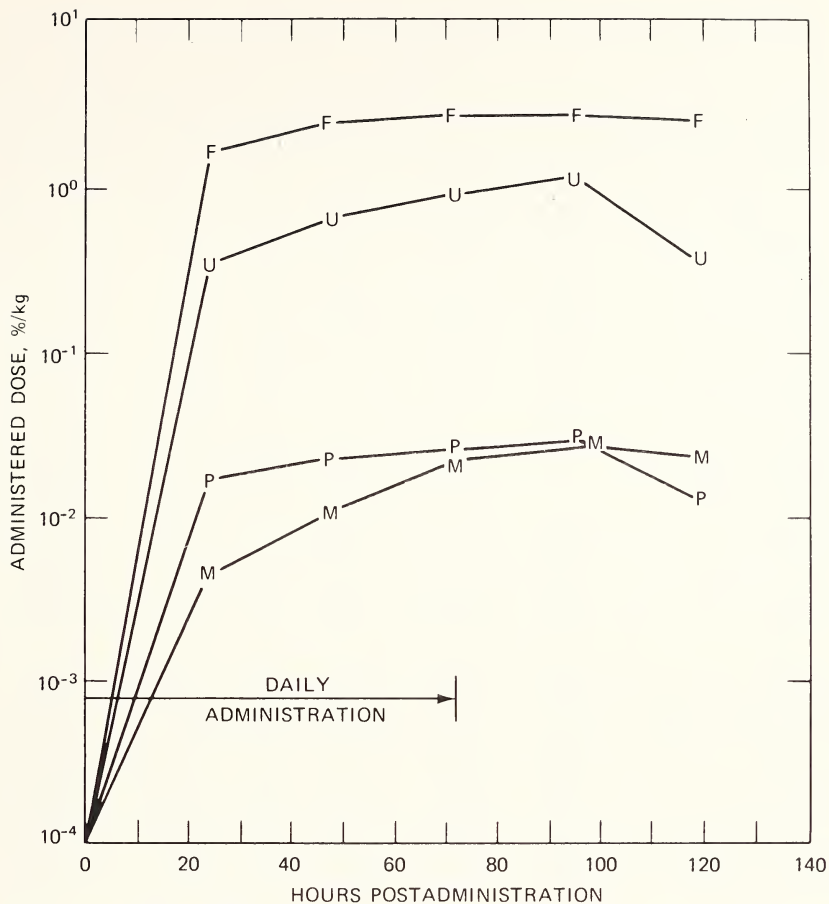

Fig. 4 Uptake curves for ^{181}W in feces (F), urine (U), milk (M), and plasma (P) following repeated daily doses of Schooner debris. Curves for ^{185}W and ^{188}W were almost identical with the exception of ^{188}W mentioned in the text.

solutions, except that 0.1% of the administered dose of ^{74}As was present in milk and 1.1% of the ^{186}Re was found in feces. Since the levels of radioactivity of the various isotopes in the debris were at least two to three orders of magnitude lower than those of the tungstens, some radionuclides would be expected to be present at or below the limits of detection.

Table 2 shows the tissue-to-maternal-plasma (T/P) ratios, in which fetal tissues are considered to be organs of the maternal organism. At the time the debris was fed, most of the shorter-lived nuclides had decayed. Those observed in tissue were ^{74}As , ^{131}I , ^{140}Ba – ^{140}La , and the tungstens. Debris radionuclides not observed in tissues were omitted from the table. In maternal tissues

Table 2

TISSUE-TO-MATERNAL-PLASMA RATIOS* OF MATERNAL AND FETAL TISSUES
FROM A PREGNANT COW FED DEBRIS FROM PLOWSHARE NUCLEAR TEST

Tissue	⁷⁴ As	¹³¹ I	¹⁴⁰ Ba	¹⁸¹ W	¹⁸⁵ W	¹⁸⁸ W- ¹⁸⁸ Re
Maternal spleen	9.8	ND†	2.25	3.4	3.0	3.3
Fetal spleen	ND	ND	5.25	0.18	ND	0.23
Maternal kidney	45.7	1.25	1.25	9.1	8.9	9.37
Fetal kidney	ND	1.85	ND	0.38	ND	0.27
Maternal plasma	1.0	1.0	1.0	1.0	1.0	1.0
Fetal plasma	ND	5.04	3.25	0.24	ND	0.20
Maternal muscle	6.5	ND	2.25	0.16	ND	0.13
Fetal muscle	ND	0.14	0.62	0.09	ND	0.09
Maternal heart	3.7	4.56	ND	0.36	0.35	0.38
Fetal heart	ND	1.39	ND	0.18	ND	0.11
Maternal thyroid	ND	1.6×10^5	ND	1.90	ND	1.30
Fetal thyroid	ND	1.8×10^5	ND	1.60	ND	1.20
Maternal liver	11.8	0.93	ND	4.54	4.16	4.36
Fetal liver	ND	1.73	ND	1.29	1.58	0.43
Maternal RBC	3.0	0.53	ND	0.47	0.41	0.43
Fetal RBC	ND	0.81	ND	0.11	ND	ND
Maternal bone	ND	ND	ND	2.80	3.00	3.00
Fetal bone	ND	0.80	7.75	5.00	5.90	5.60
Maternal cerebellum	ND	ND	ND	0.11	ND	0.11
Fetal brain	ND	ND	ND	0.60	ND	0.17
Maternal cerebrum	3.0	ND	ND	0.09	ND	0.09
Maternal bone marrow	ND	ND	ND	0.36	ND	0.20
Maternal salivary gland	7.2	ND	ND	0.63	ND	0.56
Maternal omental fat	ND	ND	ND	0.12	ND	0.12
Maternal mammary gland	2.8	2.30	ND	1.38	1.32	1.29
Maternal placenta	5.4	2.10	ND	1.25	1.46	1.33
Fetal amniotic fluid	5.3	0.49	0.75	1.01	0.96	1.04
Fetal thymus	ND	ND	5.90	0.10	ND	ND
Fetal lung	ND	ND	3.90	0.12	ND	0.10
Fetal skin	ND	1.78	0.92	0.20	ND	0.20

*The tissue-to-maternal-plasma ratio = (cpm/100 g tissue)/(cpm/100 g maternal plasma).

†The abbreviation ND, no data, indicates amounts too low for quantitation.

the ratios of ^{74}As were generally greater than unity in kidney, liver, spleen, salivary gland, and muscle (listed in decreasing order of concentration); ^{74}As was not observed in fetal tissues. It is also of interest that, although relatively large amounts of ^{74}As were observed in the maternal urine, it was not observed in milk.

The ^{131}I was low at this time (7 weeks postshot), but large amounts were concentrated both in the maternal and the fetal thyroids. The T/P ratios for ^{140}Ba were greater than unity in fetal plasma, spleen, thymus, and lung as well as in maternal spleen, kidney, and muscle. The T/P ratios for radiotungsten (^{181}W , ^{185}W , and ^{188}W – ^{188}Re) were essentially the same for each tissue; this indicates that all the tungsten isotopes behaved similarly. The ^{181}W was determined by counting its X rays with an NaI counter at a later time, the ^{185}W by measuring its 125-keV peak from the Ge(Li) spectrum, and the ^{188}W by measuring the 155-keV peak of the newly formed ^{188}Re after that originally present had decayed. Maternal kidney, liver, thyroid, and bone had T/P ratios greater than 1. Fetal bone had a T/P ratio almost twice that of maternal bone; this indicates that bone is a principal target organ for radiotungsten in the fetus. A comparison of tungsten levels in fetal tissues generally shows that the placenta acts as a partial barrier to tungsten. However, tungsten that does cross the placenta is concentrated primarily in the developing bone.

Despite such obvious sources of variation as differences in physical and chemical form in which radionuclides might exist in debris, inherent errors in counting statistics, and disparity of radionuclide concentrations in debris, a comparison of data from cows fed debris from different Plowshare experiments as well as carrier-free radionuclides shows excellent correlation. Transport of ions across the gut depends on many predictable factors; these include surface or mass distribution of radionuclides within fallout particles, their solubility product in the gut contents at different hydrogen ion concentrations (e.g., the formation of insoluble precipitates), and the binding of specific ion species to insoluble gut contents such as lignins or cellulose residues. Within single-debris experiments fecal elimination curves expressed as percentages of the administered dose per unit weight are essentially identical for the nonabsorbed radionuclides. This appears to demonstrate that the fecal elimination of debris radionuclides associated with particles less than $88\ \mu$ depends primarily on the rate of passage of digesta through the gut. Many of the nuclides in debris fall in this category (e.g., ^{54}Mn , ^{58}Co , ^{60}Co , ^{89}Zr , ^{141}Ce , etc.). On the other hand, a number of radionuclides are absorbed to varying degrees, and each of these have unique transfer coefficients to specific organs as metabolic pools. Examples of these include the iodines, arsenic, the tungstens, molybdenum, rhenium, sodium, and tritium. This group requires more-detailed studies. The data from such studies are necessary as input for the construction of predictive models such as those presented by Ng (this volume).

SUMMARY

We have presented data on the fate of gamma-emitting radionuclides in debris from the Schooner event administered orally to lactating cows. Nuclides appearing in milk were ^{131}I , ^{132}Te , ^{140}Ba , ^{181}W , ^{187}W , and ^{188}W – ^{188}Re , and those appearing in urine were ^{74}As , ^{103}Ru , ^{131}I , ^{132}Te , ^{181}W , ^{187}W , and ^{188}W – ^{188}Re . Levels of the other nuclides were too low for quantitation in biological products. At the time the maternal–fetal transport experiment was carried out, only ^{74}As , ^{131}I , ^{140}Ba , ^{181}W , ^{185}W , and ^{188}W – ^{188}Re were present in adequate amounts for quantitation. The ^{74}As did not appear to cross the placenta. The concentration of ^{131}I was similar in both the maternal and fetal thyroid glands. Fetal bone and spleen concentrated ^{140}Ba . Bone appeared to be the primary target organ for tungstens in the fetus. Transfer coefficients derived from such experimental data can be used for predicting milk and meat contamination and internal organ burdens.

ACKNOWLEDGMENT

This work was performed under the auspices of the U. S. Atomic Energy Commission.

FATE OF FALLOUT INGESTED BY SWINE AND BEAGLES

ROBERT J. CHERTOK and SUZANNE LAKE

Lawrence Radiation Laboratory, Bio-Medical Division, University of California, Livermore, California

ABSTRACT

The increased use of nuclear energy necessitates thorough investigation of the biological availability of radionuclides released to the biosphere. The radionuclides produced by a nuclear event occur in a variety of chemical and physical forms and are associated with particles of various sizes. Therefore distribution or retention data from laboratory experiments with a single, pure radionuclide cannot reasonably be extrapolated to a radionuclide in a complex mixture, as in debris. The Plowshare nuclear cratering experiments offer a unique opportunity to study the biological availability of radionuclides associated with debris from nuclear detonations.

We have taken advantage of these events to determine the retention and excretion of the gamma-emitting radionuclides produced by three Plowshare detonations and one other event. Near-surface atmospheric debris was administered orally to the experimental animals (two for each study), which were then confined to metabolic cages for the duration of the experiment (5 to 9 days). For two events the experimental animals were beagles, and for two others they were peccaries (*Tayassu tajacu*). Daily whole-body analyses were performed with a lithium-drifted germanium [Ge(Li)] detector. Daily collections of urine and feces were analyzed similarly on the same detector.

In these studies the percentage of dose absorbed is the sum of the percentage excreted in the urine and the percentage remaining in the whole body at the conclusion of the experiment. Our results indicate that for some radionuclides the percentage absorbed varies not only from literature values but also from event to event. Admittedly these variations may be due to species differences, but they are more likely due to variations in the chemical and/or physical form of the radionuclide in the debris of different events. For the radionuclides analyzed so far, ranges of absorption for the four events are ^{54}Mn , 1.0%; ^{58}Co , 4.3%; ^{74}As , 45.4%; ^{88}Y , 1.1%; ^{99}Mo , 11.5 to 31.0%; ^{103}Ru , not detectable (ND) to 5.5%; ^{122}Sb , 4.0 to 4.2%; ^{131}I , 32.7 to 78.5%; ^{132}Te , 0.9 to 24.5%; ^{140}Ba - ^{140}La , 0.5 to 4.1%; ^{141}Ce , ND to 0.5%; ^{187}W , 7.0 to 41.4%; ^{188}W - ^{188}Re , 18.2%; and ^{198}Au , 4.1 to 7.7% (the radionuclides for which only one value is given were measured in only one event).

The increased use of nuclear energy necessitates investigation of the fate of radionuclides released to the biosphere. The radionuclides produced by atomic

explosions occur in a variety of chemical and physical forms and are associated with particles of various sizes. Thus the radionuclides in debris usually differ in biological activity from the simple forms encountered in laboratory experiments.

In the nuclear cratering excavations carried out as part of the Plowshare Program for the study of peaceful uses of atomic energy, we have a unique opportunity to study the biological availability of the radionuclides in the atmospheric debris produced by an atomic detonation. We are therefore conducting as many experiments as possible in conjunction with these events to accumulate enough information to develop predictive capability in terms of the absorption and excretion rates of radionuclides produced by different kinds of nuclear events and to furnish input for models that predict the biological impact of radioactive fallout.

To date we have studied four events, of which all but the first were Plowshare tests. In these experiments atmospheric debris was collected at 1000 to 4000 ft from the sites of detonation, weighed, and placed in gelatin capsules. These were then orally administered to the experimental animals (two animals per experiment). The animals used in Events I and II were beagles; those in Events III and IV were peccaries (*Tayassu tajacu*). The peccary, a wild pig native to the southwestern United States, was chosen as an experimental animal because its small size is an advantage in whole-body counting and because its physiology closely resembles that of man. The animals were confined in metabolic cages for the duration of the experiment and were analyzed daily for the gamma-emitting radionuclides by whole-body counting with a solid-state germanium (lithium-drifted) detector and a 2048-channel pulse-height analyzer. Daily urine and feces samples were collected, preserved with formaldehyde, sealed in tuna cans of approximately 200 cc capacity, and analyzed for the gamma-emitting radionuclides on the same detector. This procedure was followed until the excreta and whole-body activities reached very low levels, between 5 and 9 days.

All the radionuclides discussed in this report are listed in Table 1 under each event, along with the percentages retained in the whole body and recovered in the urine and feces. The table also includes the values listed by the International Commission on Radiological Protection (ICRP)¹ for the fraction transferred from the gastrointestinal tract to blood. All values are corrected for physical decay. The values for radionuclide absorption used in this presentation represent the sum of the radionuclides excreted in the urine and those remaining in the whole body at the termination of the experiment. Of course, this restricted definition omits consideration of any portions absorbed and excreted by other routes (e.g., excreted in bile) or portions completely unabsorbed and still remaining in the lumen of the gastrointestinal tract.

For the first radionuclide listed, ⁵⁴Mn, the absorption (whole-body + urinary excretion) was 1.0% of the dose. The ICRP value is listed as 10.0%. However, Furchner et al.² demonstrated that ⁵⁴Mn was poorly absorbed

Table 1
WHOLE-BODY RETENTION AND EXCRETION OF DEBRIS RADIONUCLIDES EXPRESSED AS PERCENTAGES OF TOTAL DOSE

Radio-nuclide	Event I*			Event II			Event III			Event IV			Fraction from G.I. tract to blood (ICRP [†])
	Whole body†	Urine†	Feces	Whole body†	Urine†	Feces	Whole body†	Urine†	Feces	Whole body†	Urine†	Feces	
⁵⁴ Mn	4.0	27.0	73.4	7.5	11.8	60.1	2.0	9.5	72.5	1.0	ND	91.5	0.10
⁵⁸ Co	ND	ND	99.7	ND	3.4	72.5	0.2	0.7	89.5	4.3	ND	87.0	0.30
⁷⁴ As				1.0	3.2	120.6	ND	4.0	76.5	2.0	43.4	49.2	0.03
⁸⁸ Y				12.2	40.8	27.4	6.0	72.5	25.0	1.1	ND	82.9	<10 ⁻⁴
⁹⁹ Mo				8.4	3.0	85.8	1.5	23.0	69.5				0.80
¹⁰³ Ru				2.5	1.6	97.4	0.5	ND	94.0				0.03
¹²² Sb				ND	ND	112.0	0.5	ND	100.0				0.03
¹³¹ I	2.8	29.9	69.9	12.2	40.8	27.4	6.0	72.5	25.0	17.4	39.4	58.3	1.00
¹³² Te	0.6	0.3	99.8	8.4	3.0	85.8	1.5	23.0	69.5				0.25
¹⁴⁰ Ba- ¹⁴⁰ La				2.5	1.6	97.4	0.5	ND	94.0				0.05 (¹⁴⁰ Ba) <10 ⁻⁴ (¹⁴⁰ La)
¹⁴¹ Ce				ND	ND	112.0	0.5	ND	100.0				<10 ⁻⁴
¹⁸⁷ W				0.6	40.8	71.1	ND	7.0	67.5				0.10
¹⁸⁸ W- ¹⁸⁸ Re				6.7	1.0	96.5	2.0	2.1	88.0	1.9	16.3	81.7	0.10 (¹⁸⁸ W) 0.50 (¹⁸⁸ Re)
¹⁹⁶ Au										ND	7.3	95.5	0.10
¹⁹⁸ Au													0.10

*Event I was not a Plowshare event.

†The abbreviation ND means not detected.

from the gut of mice, rats, monkeys, and dogs and that after oral administration rapid fecal excretion resulted in a whole-body retention of less than 1%.

Heinrich and Gabbe³ reported that inorganic ⁶⁰Co administered orally to rats was excreted in 2 days, 90% in the feces and 15% in the urine; that remaining in the body (0.9%) had a biological half-life of 18 days. Our experiment indicates that 4.3% of the dose of ⁵⁸Co was absorbed; the ICRP value is 30%.

According to Schroeder and Balassa,⁴ pentavalent and trivalent arsenic differ markedly in their metabolism. Pentavalent arsenate, normally nontoxic, is rapidly excreted by the kidneys, whereas toxic trivalent arsenic is excreted mainly by the intestines. It seems possible that the debris of Event IV contained both forms since we found 45.4% of the administered dose to be absorbed; the ICRP value is 3%.

For ⁸⁸Y, 1.1% of the administered dose was absorbed. The ICRP value is less than 0.01%. These two values are probably statistically the same. Chemically yttrium is closely related to the lanthanides, and, on the basis of its chemical properties and metabolic behavior, ⁸⁸Y can be grouped with the heavy lanthanides.⁵ According to the results of Durbin et al.,⁶ other heavy lanthanides are poorly absorbed.

The absorption of ⁹⁹Mo ranged from 11.5 to 31.0%, compared with an ICRP value of 80%. Bell et al.⁷ reported that in swine 79% of the orally administered dose was excreted in the urine and about 12% in the feces in the first 5 days; the rate of urinary excretion was increased when the ⁹⁹Mo was diluted with carrier molybdenum. Admittedly species differences may be involved, but it is probable that the chemical and/or physical state of the ⁹⁹Mo in the debris is a major factor. The radionuclides in debris are associated with particles of various sizes and may be either surface distributed or volume distributed; both particle size and mode of distribution affect the availability of the nuclide for absorption from the gut.

Van Dilla⁸ found ¹⁰³Ru to be poorly absorbed by the gut in the rat. Our values ranged from nondetectable levels to 5.5%; the ICRP value is 3%.

Moskalev⁹ showed that about 3% of orally administered ¹²⁴Sb is absorbed from the gastrointestinal tract of rats. Our data for ¹²²Sb are in agreement; our range is from 4.0 to 4.2%. The ICRP value is 3%.

The ¹³¹I absorption in our experiments ranged from 32.7 to 78.5% of the administered dose; the ICRP value is 100%. According to the results of Busnardo and Cassan,¹⁰ however, iodine from the body pool is excreted in part in the feces. This may account somewhat for our lower absorption values, but it is probable that the chemical-physical state of the ¹³¹I was a major factor.

Wright and Bell¹¹ found that, in swine given a single oral dose of ¹²⁷Te, over 70% was excreted in the feces and approximately 20% in the urine within 120 hr. Moskalev⁹ reported similar values in rats; 10 to 25% of orally administered ¹²⁷Te was absorbed. Our range of absorption for ¹³²Te was from 0.9 to 24.5% of the dose; the ICRP value is 25%.

The isotopes of lanthanum are not absorbed through the intestinal wall to a significant degree,⁶ but ^{140}Ba is absorbed.¹² The major part of an equilibrium mixture of ^{140}Ba – ^{140}La injected intraperitoneally in rats was eliminated in the feces;¹² the kidney appeared to differentiate between ^{140}Ba and ^{140}La and to retain ^{140}La . In our experiments the animals were fed an equilibrium mixture of the two radionuclides, and the nuclide measured was ^{140}La . Our results indicate an absorption range from 0.5 to 4.1% of the dose. The ICRP values are 5% for barium and less than 0.01% for lanthanum.

It has also been shown that ^{144}Ce , too, is poorly absorbed by the gut in rats.⁸ Our values for ^{141}Ce indicate a range from nondetectable amounts to 0.5% of the dose. The ICRP value is less than 0.01%. Considering the difficulties in measuring such small quantities of ^{141}Ce and the counting statistics, the values are probably statistically the same.

Kaye¹³ has reported that a total of approximately 44% of the orally administered dose of ^{185}W and ^{187}W was excreted in the urine of rats. Our data for ^{187}W and ^{188}W – ^{188}Re range from 7 to 40.8%. The ICRP value is 10%. Other data from this laboratory indicate that 71% of the orally administered dose of ^{181}W (as K_2WO_4) is absorbed by beagles.

About 15% of ^{198}Au administered by mouth or rectum to humans in the form of colloidal or salt solutions was absorbed and excreted rather rapidly.¹⁴ For ^{196}Au and ^{198}Au , our range of absorption is from 4.1 to 7.7% of the dose. The ICRP value is 10%.

In summary, the differences between our data obtained with debris and the ICRP values can be attributed to species differences and/or the chemical–physical form of the radionuclides in debris. The importance of the latter consideration is demonstrated by our finding that absorption for the same radionuclides sometimes varies from event to event.

ACKNOWLEDGMENT

This work was performed under the auspices of the U. S. Atomic Energy Commission.

REFERENCES

1. International Commission on Radiological Protection, Report of Committee II on Permissible Dose for Internal Radiation (1959), pp. 154–230, Pergamon Press, Inc., New York, 1960.
2. J. E. Furchner, C. R. Richmond, and G. A. Drake, Comparative Metabolism of Radionuclides in Mammals. III, *Health Phys.*, **12**: 1415–1423 (1966).
3. H. C. Heinrich and E. E. Gabbe, Stoffwechselverhalten des anorganischen Kobalts und des in der vitamin B_{12} -bzw. Vitamin B_{12} coenzyme-struktur organisch gebundenen Kobalts in säugetier-organismus, *Z. Naturforsch., B*, **19**: 1032–1042 (1964).
4. H. A. Schroeder and J. J. Balassa, Abnormal Trace Metals in Man: Arsenic, *J. Chron. Dis.*, **19**: 85–106 (1966).

5. D. H. Copp, J. G. Hamilton, D. C. Jones, D. M. Thomson, and C. Cramer, The Effect of Age and Low-Phosphorus Rickets on Calcification and the Deposition of Certain Radioactive Metals in Bone, *Transactions of the Conference on Metabolic Interrelations*, Vol. 3, pp. 226-258, 1951.
6. P. W. Durbin, M. H. Williams, M. Gee, R. N. Newman, and J. G. Hamilton, Metabolism of the Lanthanons in the Rat, *Proc. Soc. Exp. Biol. Med.*, **91**: 78-85 (1956).
7. M. C. Bell, B. H. Diggs, R. S. Lowry, and P. L. Wright, Comparison of ^{99}Mo Metabolism in Swine and Cattle as Affected by Stable Molybdenum, *J. Nutr.*, **84**: 367-372 (1964).
8. M. A. Van Dilla, Zinc-65 and Zirconium-95 in Food, *Science*, **131**: 659-660 (1960).
9. Y. I. Moskalev, Distribution of Antimony-124 and Tellurium-127, in *Raspredelenie, Biologicheskoe Deistvie, Uskorenie Vyvedeniya Radioaktivnykh Izotopov*, pp. 62-70, Meditsina, Moscow, 1964. (In Russian)
10. B. Busnardo and F. Casson, Aspects of Fecal Iodine Excretion in Man, *Acta Isotop.*, **5**: 5-13 (1965).
11. P. L. Wright and M. C. Bell, Comparative Metabolism of Selenium and Tellurium in Sheep and Swine, *Amer. J. Physiol.*, **211**: 6-10 (1966).
12. V. R. Sastry and L. K. Owens, Fission Products: Retention and Elimination of the Parent-Daughter Radionuclide Pair Barium-140-Lanthanum-140 by Rats, *Toxicol. Appl. Pharmacol.*, **9**: 431-444 (1966).
13. S. V. Kaye, Distribution and Retention of Orally Administered Radiotungsten in the Rat, *Health Phys.*, **15**: 399-417 (1968).
14. H. Kleinsorge, Absorption of Therapeutic Gold Salts and Gold Sols, *Arzneim.-Forsch.*, **17**: 100-102 (1967).

RADIONUCLIDE BODY BURDENS AND HAZARDS FROM INGESTION OF FOODSTUFFS CONTAMINATED BY FALLOUT

YOOK C. NG* and HOWARD A. TEWEST†

*Bio-Medical Division and †K Division,
Lawrence Radiation Laboratory, University of California,
Livermore, California

ABSTRACT

A method developed for predicting the internal dose that could result when radionuclides are released to the atmosphere and deposited on agricultural land has been used to extend earlier studies of the problems associated with food contamination following a nuclear attack. The study considers activation products as well as fission products and attempts to take into account recent data on retention and rate of loss by weathering of both small and large particles on plants, on uptake of nuclides into dietary constituents, and on biological availability of nuclides in nuclear debris. In this study potential levels of food contamination and internal dose commitment are estimated both for the immediate postattack period and for the year closely following the attack when the initial deposition rates of stratospheric debris would be highest. The results are discussed in the light of the modifying factors that would influence them.

A method for predicting the internal dose that could result when radionuclides are released to the atmosphere and deposited on agricultural land¹ was developed to assess the potential burden and dosage to man which could result from the release of nuclides to the biosphere from any source. By means of this analysis, we can identify the nuclides that could contribute most to the internal dose and determine the contribution of each nuclide to the total dose.

This paper considers the application of this method to examine possible postattack levels of contamination of terrestrial foods and the dosages that could result from their consumption and extends earlier studies of the problems associated with food contamination immediately following a nuclear attack.²⁻⁴ The work considers activation products as well as fission products and takes into account more-recent data on retention of small and large particles on plants and their subsequent rate of loss by weathering, on uptake of nuclides into dietary

constituents, and on biological availability of nuclides in nuclear debris. It also attempts to assess the levels of food contamination that could result from the initial deposition rates of the nuclear debris injected into the stratosphere.

We make certain simplifying assumptions in order to apply our models to estimate the potential levels of contamination of foods and the internal dose commitment to man. We then examine the results and note how various modifying factors would influence them.

METHOD FOR ESTIMATION OF DOSAGE

Our predictive model combines source, transport, and interaction terms to estimate possible levels of contamination of foodstuffs and possible internal dosages that could result from their consumption. "Source" refers to the radionuclides produced and their quantities. The source term consists of the activity of each radionuclide produced in the detonation. "Transport" refers to the transport of nuclides from the site of detonation and their subsequent distribution to the biosphere. The combination of transport and source terms yields either the deposition or the rate of deposition from the atmosphere. "Interaction" refers to the interaction of the nuclides with the biosphere, i.e., their entry into food chains and subsequently into the tissues of man. The interaction terms directly relate deposition or deposition rates and air concentrations to levels of contamination in foods and to internal dosages. The general approach is described in detail elsewhere,^{1,5} and the input parameters required for the analysis are available in a continuously updated handbook.*⁶

The present analysis is confined to contamination of terrestrial foods as a result of foliar contamination by fallout. Early deposition of local and tropospheric fallout would usually result in a far greater level of contamination of vegetation than that from subsequent root uptake of the fallout deposited on soil. Similarly, the early rates of deposition of stratospheric debris can be expected to cause higher levels of plant contamination than would subsequent root uptake from the cumulative deposition in soil.

This analysis focuses on the forage-cow-milk and plant-herbivore-meat pathways. Both milk and meat are important constituents of the human diet, and much is known regarding their input parameters. Since relatively large contaminated areas can be grazed daily by cows and other herbivores, the milk and meat pathways are important for many nuclides. For milk the period between the deposition of fallout and the ingestion of the contaminated food can be especially short.

*No attempt is made in this paper to list the input parameters used in the calculations. Input parameters and a comprehensive bibliography of the sources from which they were obtained appear in a continuously updated handbook.⁶ Many of the parameters used are updated values that will appear in the forthcoming revision of the handbook. This issue will be available on request.

This analysis considers both the immediate postattack impact on food contamination, which is attributable to local and tropospheric fallout, and the longer-term impact, which is attributable to the continuous deposition of nuclides from the stratosphere.

Case studies of hypothetical nuclear attacks on the United States provide a useful frame of reference for the analysis of problems relating to civil defense. For example, two cases of hypothetical attacks, the CIVLOG and the UNCLEX, were used as starting points in planning for postattack recovery.⁷ Other cases of hypothetical attacks were used by Brown and his associates at the Stanford Research Institute in the assessment of "national entity vulnerability."³ The general magnitude and structure of these attacks in large measure compare with those of CIVLOG and UNCLEX.

For the immediate purpose of predicting the dosage that could result from the ingestion of contaminated foods, we do not need to make fine distinctions. Thus we have simply adopted some of the features of these case studies. We arbitrarily assumed an attack of about 1000 surface-detonated weapons with a total yield of 4000 Mt. These weapons are assumed to be half-fission half-fusion devices with individual yields between 1 and 10 Mt. It will be readily apparent how the results would scale with other combinations of total and individual yields.

RADIONUCLIDE SOURCE TERMS

The radionuclides produced by the detonation of thermonuclear weapons include fission products, activities induced in device and environmental materials, and tritium. In this section source terms are derived for the 1-Mt-yield explosive, which is taken as the unit to be scaled linearly to higher yields.

Fission Products

Fission products derived from weapons test have been studied extensively over the past 20 years. We used the fission yields listed by Weaver et al.⁸

Neutron-Activation Products of Device and Environmental Materials

From the standpoint of potential external dose from the fallout gamma field, the fission products resulting from the hypothetical half-fission half-fusion 1-Mt explosive represent the most important contribution, although nuclides resulting from neutron interactions with unburned fissionable material can represent up to 40% of the total activity of the weapon debris.⁹ However, because of special concentrating mechanisms, "minor" neutron-activation products could still contribute appreciably to the internal dose following their entry into certain food chains. Therefore the total production is estimated for a number of these activation products that were not considered heretofore in the estimation of fallout fields from weapon detonations.

Activation of Unreacted Fissionable Materials

Predominant isotopes in the category of unreacted fissionable materials are ^{237}U , ^{239}U , ^{239}Np , and ^{240}Np (Ref. 9). However, neither the ^{239}U nor the ^{240}Np source terms are estimated since their relatively short half-lives (23.5 min and 60 min, respectively) preclude their contributing to internal doses delivered via food chains.

Kimura,¹⁰ as quoted by Miller,¹¹ indicates that for the Bravo detonation, there were 0.3 neutron captures per fission in ^{238}U ; thus for 500 kt of fission a total of 2.2×10^{25} atoms of the mass-239 chain ($^{239}\text{U} \rightarrow ^{239}\text{Np} \rightarrow ^{239}\text{Pu}$) would be produced. This estimate can be compared with that of Langham and Anderson¹² that 3600 Ci of ^{239}Pu are produced per megaton of fission (the equivalent of about one neutron capture per fission in ^{238}U). This more conservative estimate is used in the present assessment. Kimura¹⁰ determined that approximately 0.15 atom of ^{237}U per fission was produced by the Bravo event of 1952. Using this source term, we find that 500 kt of fission results in the formation of about 1.1×10^{25} atoms of ^{237}U .

Activation of Device Materials (Including Canister)

A considerable body of work has been reported on atmospheric concentrations and burdens of radioactive species produced during the nuclear tests of 1961 and 1962. Summaries by Feely et al.¹³ and by Thomas et al.¹⁴ indicate that the stratospheric residence half-time of all weapon-produced radionuclides is approximately 10 months; hence total atmospheric burdens of the predominant radioactive species measured in 1963 or later must characterize uniquely the 1961–1962 injections.

As confirmation of this hypothesis, Feely et al.¹³ determined that the total atmospheric burden of ^{90}Sr (corrected to July 1, 1962) was 10 MCi; since the total fission yield of the 1961–1962 atmospheric detonations has been estimated as 101 Mt¹⁵ and the ^{90}Sr production from a "typical" device has been reported as 0.1 MCi per megaton of fission,*¹² we can see that the measured burden represents essentially the total calculated inventory of ^{90}Sr . At the same time, Feely et al.¹³ found the total atmospheric burden of ^{54}Mn to be about 57 MCi (corrected to July 1, 1962); this represents a production source term of about 0.0056 atom per fission.

In an independent study, Thomas et al.¹⁴ determined that the activity ratio of ^{54}Mn to ^{137}Cs , as measured on filters mounted on high-volume near-surface air samplers, was about 3.9. If we assume that 0.14 MCi of ^{137}Cs is produced per megaton of fission, we find that the production source term for ^{54}Mn is 0.0036 atom per fission. When the two determinations are averaged, the production of ^{54}Mn appears to be of the order of 0.0046 atom per fission. Since

*As quoted by Eisenbud.¹⁶

the total yield of the 1961–1962 detonations¹⁵ was 337 Mt, an average source term of 1.4×10^5 Ci of ^{54}Mn per megaton of total yield can be inferred.

Table 1 summarizes activity ratios for a number of radionuclides measured in air and gives the references from which the ratios were abstracted. This table also includes some heretofore unpublished isotope ratios measured in debris from the Schooner event.¹⁷

Table 1
ACTIVITY RATIOS (RELATIVE TO ^{54}Mn) FOR A NUMBER
OF NEUTRON ACTIVATION PRODUCTS

Nuclide	Activity ratio* (Relative to ^{54}Mn)	Source	Ref.
^{22}Na	1.4×10^{-3}	1961–1962 test series	14
^{56}Mn	6700	Schooner	63
^{55}Fe	2.0	1961–1962 test series	64
^{59}Fe	0.091	Schooner	63
^{57}Co	0.65	Schooner	63
^{58}Co	3.1	Schooner	63
^{60}Co	2.2×10^{-3}	1961–1962 test series	14
^{65}Zn	2.4×10^{-2}	1961–1962 test series	14
$^{110\text{m}}\text{Ag}$	2.2×10^{-3}	1961–1962 test series	14
^{134}Cs	9.3×10^{-4}	1961–1962 test series	14

*Activity ratios obtained from debris resulting from the 1961–1962 test series were calculated for July 1, 1962; activity ratios from the Schooner experiment were corrected to the time of detonation.

Activation of Environmental Materials

One of the potentially significant radionuclides created by nuclear detonations conducted in the atmosphere is ^{14}C . Machta¹⁸ estimates that the total production over all atmospheric tests to date is 9.17×10^{28} atoms; since the cumulative yield of such tests¹⁵ is about 511 Mt, the average production is about 20,000 Ci/Mt.

Since most of the nuclear tests of the 1961–1962 series were airbursts, smaller quantities of soil activation products were produced and injected into the atmosphere than would be expected from surface bursts of the same total megatonnage. Certain radionuclides of environmental origin can be expected to be potentially important contributors to the internal radiation dose following entry into food chains and consumption by man. For example, ^{32}P , ^{24}Na , ^{86}Rb , ^{45}Ca , ^{84}Rb , ^{134}Cs , ^{47}Ca , and ^{22}Na are neutron-activation products of soil and rock that are potentially important via milk.¹ Except for ^{22}Na and ^{134}Cs , measurements of neutron-activation products of soil and rock produced by nuclear device testing have not been reported in the open literature. The

production of these nuclides was therefore estimated using a calculational approach previously reported in the literature.^{19,20}

The neutron-activation calculations assume that 14-MeV neutrons are incident on granite. By assuming 14-MeV neutrons, we maximize the production of ^{84}Rb , ^{47}Ca , and ^{22}Na . The neutron yield per megaton of fusion is assumed to be 1.45×10^{27} neutrons, the oft-cited figure assumed by Leipunsky.²¹ If we accept the estimate of ^{14}C production reported in this section and assume that essentially all the neutrons released to the environment are captured by atmospheric nitrogen with the resultant formation of ^{14}C , some 2×10^{26} neutrons are released to the environment per megaton of fusion. This assumption is not unreasonable since most of the nuclear tests of the 1961–1962 series were airbursts and since the bulk of the neutron-absorption cross section of the atmosphere is attributable to nitrogen. Furthermore, the calculations of Lessler and Guy¹⁹ indicate that for airbursts at a height of 1000 m only about 1% of the neutrons released to the environment are captured by soil at ground level.

The release of 2×10^{26} neutrons per megaton combined with the total production of 1.45×10^{27} neutrons per megaton of fusion suggests that some 13 to 14% of the neutrons produced are released to the environment. This compares with the 20% escape fraction previously assumed by Libby.²² Our estimates therefore assume that 400 moles of neutrons per megaton of fusion are released to the environment; this is equivalent to an escape fraction of about one-sixth. One-half of the neutrons escaping the device (i.e., 200 moles per megaton of fusion) are assumed to be captured in rock or soil following a surface detonation. Estimates of the production of ^{22}Na and ^{134}Cs based on the activity ratios of Table 1 suggest that, in the 1961–1962 test series, 3 to 4 moles of neutrons were released to soil per megaton. This observation is not inconsistent with our assumption if we remember that the 1961–1962 detonations were largely airbursts. Furthermore, special neutron-shielding materials would have to be employed to reduce the neutrons released to the environment to levels as low as 3 or 4 moles per megaton of fusion.²³

Tritium

Dose estimates from tritium are considered elsewhere in this volume,²⁴ but its source term is included here for the sake of completeness. Leipunsky²¹ indicated that the amount of residual tritium per megaton of thermonuclear yield was about 0.7 kg. Miskel²⁵ gave a range of from 0.7 to 5 kg/Mt, and, more recently, Tewes²⁶ reported that the residual tritium was on the order of 2 kg per megaton of thermonuclear yield. We will use the Tewes estimate.

Summary of Radionuclide Source Terms

The data in the preceding section are summarized in Tables 2 and 3. Table 2 lists the source terms for fission products, and Table 3 lists the source terms for

Table 2
FISSION-PRODUCT SOURCE TERMS
FOR 1-MT FISSION EXPLOSIVE

Nuclide	Curies produced*	Nuclide	Curies produced*
^{89}Sr	1.5×10^7	$^{131\text{m}}\text{Te}$	2.0×10^8
^{90}Sr	8.8×10^4	^{132}Te	4.4×10^8
^{99}Mo	6.2×10^8	^{131}I	1.5×10^8
^{103}Ru	3.5×10^7	^{133}I	2.1×10^9
^{106}Ru	2.1×10^6	^{136}Cs	2.0×10^7
^{125}Sn	2.6×10^7	^{137}Cs	1.5×10^5
^{125}Sb	3.3×10^5	^{140}Ba	1.1×10^8
$^{129\text{m}}\text{Te}$	6.0×10^5	^{144}Ce	3.6×10^6

*Values are corrected to detonation time.

tritium and activation products. Included in Table 3 are not only the specific production terms in atoms and curies per megaton but also the "equivalent fission yields" of the various species. From the standpoint of contribution to the gamma fallout field, neutron-activation products represent a relatively small fraction when compared with fission products.

Figure 1 shows the number of curies of radioactivity resulting from the detonation of the hypothetical 1-Mt explosive and the decay of this radioactivity with time. The radionuclides produced by neutron activation of the unfissioned uranium represent a significant fraction of the total radioactivity during the first few weeks after detonation.

We should emphasize at this point that the radioactivity source term developed here does not necessarily represent that which would be produced by any existing nuclear weapon; however, the various radionuclides considered here would certainly be produced in some quantity by the surface detonation of any weapon. Details of device construction and variations in soil composition obviously could drastically affect the amounts that would be formed of almost every species. This work, however, is expected to give at least some guidance in the estimation of possible internal radiation exposures from nuclides other than fission products and possibly to serve to identify isotopes that could be especially troublesome.

PREDICTION OF THE INTERNAL DOSAGE FROM EARLY DEPOSITION

We define a standard fallout field as one that would deliver an exposure rate of 100 R/hr at 1 hr postdetonation. The total dose resulting from exposure to such a field starting at H + 8 hr would be about 250 R. (For a more detailed discussion of this subject, see Ref. 9, Chap. IX.) The total dose resulting from exposure beginning at H + 4 hr would be about 300 R. The dosages would

Table 3
TRITIUM AND ACTIVATION-PRODUCT SOURCE TERM
FOR 1-MT NUCLEAR EXPLOSIVE*

Nuclide	Source‡	Total produced		Equivalent fission yield,† kt	
		Atoms	Curies	Dose rate (H + 1 hr)	Dose (H + 1 hr to ∞)
³ H	1	2×10^{26}	1.0×10^7		
¹⁴ C	2	1.8×10^{26}	2×10^4		
²² Na	2	2×10^{22}	4.5×10^3	3×10^{-5}	0.25
²⁴ Na	2	3×10^{24}	1×10^9	9	60
³² P	2	3×10^{22}	4×10^5		
⁴² K	2	3×10^{23}	1.2×10^8	8×10^{-2}	0.4
⁴⁵ Ca	2	3×10^{22}	4×10^4		
⁵⁴ Mn	3	2×10^{23}	1.4×10^5	3×10^{-4}	1.0
⁵⁶ Mn	3	4×10^{23}	9×10^8	4	4
⁵⁵ Fe	3	1.2×10^{24}	3×10^5		
⁵⁹ Fe	3	3×10^{21}	1.3×10^4	5×10^{-5}	2×10^{-2}
⁵⁷ Co	3	1.1×10^{23}	9×10^4	3×10^{-5}	8×10^{-2}
⁵⁸ Co	3	1.3×10^{23}	4×10^5	1.1×10^{-3}	0.7
⁶⁰ Co	3	3×10^{21}	3×10^2	2×10^{-6}	4×10^{-2}
⁶⁵ Zn	3	3×10^{21}	3×10^3	4×10^{-6}	1.0×10^{-2}
⁸² Br	2	7×10^{20}	1.1×10^5	7×10^{-4}	1.1×10^{-2}
⁸⁴ Rb	2	7×10^{21}	4.5×10^4	1.1×10^{-4}	4×10^{-2}
⁸⁶ Rb	2	2×10^{22}	2×10^5	6×10^{-5}	1.1×10^{-3}
^{110m} Ag	3	3×10^{20}	3×10^2	2×10^{-6}	5×10^{-3}
¹³⁴ Cs	2	1.8×10^{22}	5×10^3	2×10^{-5}	0.16
²³⁷ U	4	1.1×10^{25}	4×10^8	0.14	9
²³⁹ Np	4	7×10^{25}	6×10^9	3	70

*Values are calculated exclusive of fission products and assuming 500 kt of fission and 500 kt of fusion yield.

†The equivalent fission yield⁶⁵ of a radionuclide, expressed as a dose rate at H + 1 hr, is defined as "that amount of fission required to produce fission products which, at H + 1 hour, will emit gamma-ray energy at the same rate as does the amount of the particular radionuclide under consideration." Similarly, the equivalent fission yield of a radionuclide, expressed as total dose delivered after H + 1 hr, is defined as "that amount of fission required to produce fission products which will emit (after H + 1 hour) the same total amount of gamma-ray energy as will the amount of the particular radionuclide under consideration."

‡The numbers indicate the following sources: 1, residue from thermonuclear reactions; 2, from neutron activation of environmental material; 3, from neutron activation of explosive components; and, 4, from neutron activation of unfissioned uranium.

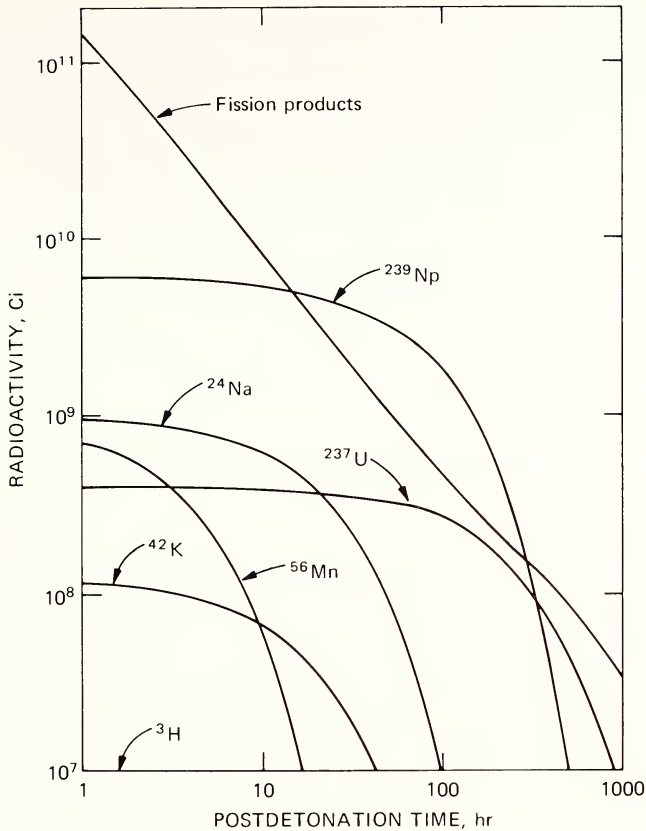

Fig. 1 Radioactivity from 1-Mt explosive with a fission-to-fusion ratio of 1.0. The activity values are derived from Table 3.

actually be about 0.7 as great, because of terrain shielding, and would be further reduced if protection were available and were utilized. Thus a unit-time dose rate not exceeding 100 R/hr would be compatible with effective survival of a substantial segment of the population.^{2,7} Roughly 50% or more of the land area of the nation would be outside the 100 R/hr contour from the hypothetical attack.^{3,7}

Fractional Deposition of Early Fallout

If we accept a theoretical unit-time dose rate of 3700 R/hr in association with the uniform deposition of 1 kt of fission products per square mile of surface, a unit-time dose rate of 100 R/hr from unfractionated fission products is equivalent to a deposition of 1.05×10^{-8} kt of fission products per square meter of surface. (See Ref. 9, Sec. 9.183–9.184.) We have assumed that the

contributions of neutron-activation products to the gamma field are small and, conservatively, that a unit-time dose rate of 100 R/hr is equivalent to a deposition of fission products totaling 10^{-8} kt/m². By these assumptions, an equivalent yield of neutron-activation products would be produced by the 10^{-8} kt of fusion and would also be deposited per square meter. For a single 1-Mt detonation, a deposition of 10^{-8} kt/m² corresponds to a fractional deposition of 10^{-11} per square meter and, for a 10-Mt detonation, to a fractional deposition of 10^{-12} per square meter. Fallout levels observed subsequent to nuclear-device testing at the Nevada Test Site indicate that fractional depositions in the range from 10^{-11} to 10^{-12} per square meter could be expected within 20 hr after detonation.^{2,8} Both neutron-activation products and fission products are assumed to be deposited as unfractionated activities. The implications of assuming unfractionated deposition are considered later.

Initial Retention on Vegetation and Rate of Loss by Weathering

Physical Character of Deposition

The cloud from a single 1-Mt surface burst in the latitude band 30 to 90° N can be expected to stabilize between altitudes of 26,000 and 53,000 ft; the cloud from a single 10-Mt burst can be expected to stabilize^{2,9} between 50,000 and 100,000 ft. Calculations based on Stoke's law can be made to estimate the minimum size of particles that can be deposited from these elevations under the influence of gravity alone. (See Ref. 9, Sec. 9.186–9.187.) These estimates suggest that, if the 100 R/hr contour represented fallout deposited 4 to 12 hr after detonation, particles of diameter $>200 \mu$ would deposit inside the contour and particles of diameter $<50 \mu$ would deposit outside. A dominant particle-diameter range of 50 to 200 μ could be expected in the fallout deposited along the 100 R/hr contour from a single surface burst. Dry deposition of nonfalling particles would not be significant at these early times.³⁰

Taking into account the total of all surface bursts contributing to the 100 R/hr fallout field, we anticipate (1) earlier times of arrival than previously assumed, which means deposition of particles larger than 200 μ , and (2) deposition of particles less than 50 μ originating from the more distant detonations. Small particles could also be deposited by rain. Predictions for the concentrations of nuclides in foods subsequent to the deposition of fallout should take into account the particle-size distribution that would be encountered. Accordingly two sets of predictions have been made. One set is based on data obtained from large particles, i.e., particles 50 to 200 μ and greater in diameter; the other is based on data obtained from small particles ($<30 \mu$) and worldwide fallout. We anticipate that, in general, the estimates of higher dose rates would more properly be based on the estimates of food contamination from large particles, whereas the estimates of lower dose rates would be based on those from small particles.

Behavior of Small Particles

The initial retention of small particles on vegetation is based on Chamberlain's analysis³¹ of data from short-term experimental releases of vapors and aerosols. The fraction of the deposited activity initially retained on vegetation, p , is approximated by the relation

$$1 - p = \exp - \mu w \quad (1)$$

where μ is the absorption coefficient in square meters per kilogram and w is the herbage density in kilograms per square meter of dry matter. The initial retention of small particles ($\leq 30 \mu$ in diameter) on grass was characterized by μ values of 2.3 to 3.3 m^2/kg . On the basis of Chamberlain's analysis, the initial retention factor for herbage densities between 0.2 and 0.4 kg/m^2 would vary between 30 and 70%. In our treatment the initial retention factor for small particles on forage is assumed to be two-thirds (67%).

In Thompson's review of the half-residence time and effective half-life of fallout on pasture plants, the half-residence time was noted to be independent of isotope and to vary in most cases between 9 and 14 days.³² Recently Chamberlain³¹ examined the data obtained from field experiments on the loss of small-particle activity from foliage. The field-loss coefficient was found to be of the order of 0.05 per day during the growing season, but lower values were observed in winter. Our estimates assume that the half-residence time of small particles on forage is 14 days; this is equivalent to a rate of loss by weathering of 0.05 per day.

Behavior of Large Particles

Table 4 is a summary of data obtained from field experiments by Witherspoon and Taylor³³ and Johnson and Lovaas^{34,35} on the initial retention of large-particle fallout simulants on forage plants. The table also includes retention data of volcanic particles as reported by Miller.³⁶ The initial retention is expressed where possible both as the percentage of fallout initially intercepted and retained by foliage and as the plant contamination factor, a . The plant contamination factor was defined by Miller as

$$a = \frac{\text{activity per unit mass dry matter on foliage}}{\text{activity per unit area of ground}}$$

A main feature of the design of the experiments of Table 4 is the early sampling, which permitted the measurement of plant retention before significant field losses could occur.

We excluded from Table 4 the initial retentions obtained under "damp" conditions (relative humidity $>90\%$). Plant contamination factors of volcanic particles as reported by Miller were enhanced by about a factor of 2 under damp

Table 4
INITIAL RETENTION OF LARGE PARTICLES ON FORAGE PLANTS

Species	Particle diameter, μ	Initial retention		Wind, mph	Rain, in.	Ref.
		Average (range), %	Average or range, m^2/kg			
Lespedeza	44 to 88	7.5	3.71	0 to 7	2.5 to 3	33
	88 to 175	1.9	0.93	0 to 7	2.5 to 3	33
Alfalfa	88 to 175	6.5	0.45	6		35
		17	0.8	0 to 10		35
		23 (16 to 35)	1.1	None	Trace	34, 35
	175 to 350	7.2 (5 to 12.2)	0.28	0 to 20		34, 35
		15	0.65	4	Dew	35
		3	0.17	6		35
Bromegrass	88 to 175	6	0.25	2 to 10		35
		5 (2.1 to 13.1)	0.24	None		34, 35
	175 to 350	4.5	0.3	6		35
		7.4 (3.1 to 10.9)	0.74	None	Light rain	34, 35
		0.4	0.04	7		35
Sundan grass	88 to 175	8.5	0.4	2 to 4		35
	175 to 350	7.5	0.25	2 to 4		35
"Grass"	*		6.7	0 to 2		36
Barley grass†	*		2.4 to 12.6	1 to 8		36
Oat grass†	*		2.4 to 7.3	1 to 8		36
Rye grass†	*		2.2 to 10.4	1 to 9		36
Wheat grass†	*		2.1 to 10.4	1 to 9		36

*Estimated range of particle size is 10 to 250 μ , and mass median diameter is \sim 50 to 80 μ .

†With reference to cereal grains, "grass" means the aerial parts prior to the development of grain heads.

conditions of exposure. In this connection Johnson and Lovaas noted that the retention on bromegrass of particles 88 to 350 μ in diameter approached or reached 100% in the presence of heavy dew. We also excluded measurements obtained when exposure was accompanied by strong winds (>20 mph). Typical amounts of rain were encountered during some of the experiments represented in Table 4.

The data of Witherspoon and Taylor³³ and Johnson and Lovaas^{34,35} suggest that 0.5 to 0.6 m^2/kg might be a typical value for the plant contamination factor for 88- to 350- μ particles on forage plants. Under these

conditions a cow consuming 10 to 12 kg of dry matter per day would effectively graze about 5 to 7 m² of contaminated land per day. This is about one-fifth of the 30 m²/day assumed to be utilized by the cow when small particles are deposited ["utilized area factor" (UAF), 45 m²/day; plant retention factor, 0.67]. Miller's data³⁶ suggest that the plant contamination factor for local fallout on forage plants would be an order of magnitude greater, i.e., about 5 to 6 m²/kg. The land area effectively utilized daily by a cow consuming 10 to 12 kg/day of dry matter would then be about 60 m²/day, which is comparable within a factor of 2 to the area assumed to be utilized by the cow when small particles are deposited. The volcanic ash studied by Miller apparently was of a somewhat smaller range of particle sizes, having a maximum diameter of about 240 μ and a mass median diameter we estimate to be about 50 to 80 μ , as far as can be determined. Interestingly, a plant contamination factor of 3.7 m²/kg was obtained by Witherspoon and Taylor for 44- to 88- μ particles on lespedeza.

The half-residence time of large particles on forage plants was also studied in these experiments. In the experiments of Witherspoon and Taylor,³³ the retention curve of simulated fallout particles on crop plants was characterized by a number of weathering half-lives. We estimated the integrated retention on lespedeza from these data and found it to be about 5.4 days for 44- to 88- μ particles and 6.7 days for 88- to 175- μ particles. If we assume a simple exponential retention function, these integrated retentions correspond to a half-residence time of 3.7 to 4.7 days. In the experiments of Johnson and Lovaas,³⁵ less rainfall occurred and somewhat longer half-times were noted. Half-times on alfalfa, bromegrass, and sudan grass were about a week or longer. Miller's data³⁶ on volcanic particles suggest a much more rapid rate of loss by weathering, with half-times being measured in hours. For example, on the basis of the median wind-weathering factor obtained for broadleaf grasses, the field-loss coefficient would be 0.2 per hour when the average wind speed is 2 mph; this is equivalent to a half-residence time of 3.5 hr (about 0.15 day), which represents about a hundredfold reduction of the 14-day half-residence time assumed for small particles on forage. On the other hand, a small fraction of the particles deposited on vegetation, of the order of 2 to 10%, was found to be "nonremovable" and was quantitatively retained.

The effect of large-particle deposition on the estimates of food contamination and dosage is evaluated later by assuming a plant contamination factor of 0.5 m²/kg, in accord with the observations of Witherspoon and Taylor³³ and Johnson and Lovaas.^{34,35} A plant contamination factor of this magnitude is equivalent to a retention of 12 to 13%, which is about one-fifth that assumed for small-particle deposition. The estimates for large-particle deposition will be made assuming a half-residence time on forage of 4 days. This is consistent with our integrated retention calculated from the observations of Witherspoon and Taylor and does not depart significantly from the somewhat longer half-times observed by Johnson and Lovaas.

Forage-Cow-Milk Pathway (Small Particles)

In the forage-cow-milk model,¹ the fallout deposited on pasture is continuously ingested by the grazing cow. The UAF is assumed to be 45 m²/day; i.e., the cow is assumed to utilize 45 m² of pasture daily. This value is based on Koranda's review of agricultural factors affecting the intake of dairy cows, in which a median UAF value of 45 m²/day was found for dairy cows in the United States.^{3,7} The initial daily rate of ingestion by the cow of a given nuclide (I_0) in microcuries per day is then given by

$$I_0 = R \times \text{UAF} \times F_0 \quad (2)$$

where R is the initial retention factor and F_0 is the initial deposition in microcuries per square meter. In presenting the estimates of food contamination and dosage, we report the results for small particles first since they are higher. Please recall that R is assumed to be 0.67 for small particles.

Concentration of Nuclides in Milk

Tables 5 and 6 list the estimated peak concentrations in milk from the deposition of small particles; Table 5 shows the results for fission products and Table 6 the results for activation products. In these tables f_M is the transfer coefficient to milk, the fraction of the element ingested daily by the cow which is secreted per liter of milk. These transfer coefficients include corrections for the observed biological availability, where it is known, of the nuclide in fallout.⁶ Some of the correction factors were obtained by Potter^{3,8-40} in experiments of the kind reported in this volume.

The peak concentrations in milk, C_M , are given both as the fraction of the initial daily intake, I_0 , per liter and in microcuries per liter. The concentrations were calculated on the basis of the rate of disappearance of nuclides in milk following a single administration to the lactating cow. If the turnover rate of a nuclide in milk was not available from the literature, an instantaneous steady state was assumed with respect to the secretion of activity in milk following deposition on forage. In these cases, C_M expressed as a fraction of I_0 is numerically the same as f_M . Note that input parameters are well known for the nuclides that contribute most to the dosage.

Estimated Dosage via Milk

Tables 7 and 8 present the dosage estimates via milk from the deposition of small particles. Table 7 presents the estimates for fission products and Table 8 those for activation products. The first column of each table lists the total activity ingested assuming milk consumption at the rate of 1 liter/day. The second and third columns of each table list the dose commitment to the whole body and bone of an adult. As previously recognized,¹ the nuclides that

Table 5
ESTIMATED PEAK CONCENTRATION IN MILK FROM
DEPOSITION OF SMALL PARTICLES (FISSION
PRODUCTS ONLY)*

Radionuclide	f_M /liter/day†	C_M †	
		Fraction of I_0 per liter	$\mu\text{Ci/liter}$
^{89}Sr	9.0 (-4)	6.7 (-4)	3.1 (0)
^{90}Sr	9.0 (-4)	7.2 (-4)	1.9 (-2)
^{99}Mo	7.5 (-4)	3.5 (-4)	6.5 (1)
^{103}Ru	1.0 (-6)	1.0 (-6)	1.0 (-2)
^{106}Ru	1.0 (-6)	1.0 (-6)	6.3 (-4)
^{125}Sn	1.0 (-3)	1.0 (-3)	8.0 (0)
^{125}Sb	5.0 (-6)	5.0 (-6)	4.9 (-4)
^{129m}Te	1.25 (-4)	8.3 (-5)	1.5 (-2)
^{131m}Te	1.25 (-4)	2.3 (-5)	1.4 (0)
^{132}Te	1.25 (-4)	4.3 (-5)	5.6 (0)
^{131}I	5.0 (-3)	2.5 (-3)	1.1 (2)
^{133}I	5.0 (-3)	1.0 (-3)	4.6 (2)
^{136}Cs	7.5 (-3)	3.2 (-3)	1.9 (1)
^{137}Cs	7.5 (-3)	4.8 (-3)	2.1 (-1)
^{140}Ba	1.5 (-4)	7.8 (-5)	5.1 (0)
^{144}Ce	2.0 (-5)	2.0 (-5)	2.1 (-2)

*Deposition is assumed to be 10^{-8} kt of fission products per square meter.

†The numerical value in parentheses signifies the exponential power of 10; thus 9.0 (-4) signifies 9.0×10^{-4} .

contribute most to the dose commitment via milk are the fission products ^{89}Sr , ^{90}Sr , ^{99}Mo , ^{132}Te , ^{131}I , ^{133}I , ^{136}Cs , ^{137}Cs , and ^{140}Ba and the activation products of soil and rock, ^{22}Na , ^{24}Na , ^{32}P , ^{45}Ca , ^{47}Ca , ^{84}Rb , ^{86}Rb , and ^{134}Cs . All the parameters required for the forage-cow-milk model are adequately known for all these nuclides. Activation products of device materials do not contribute appreciably to the total dose commitments. The isotopes whose input parameters via milk are not well known include ^{125}Sn (Table 7) and ^{110m}Ag , ^{237}U , and ^{239}Np (Table 8). Since conservative estimates were assumed, the dosages may be overconservative. These isotopes, however, do not make substantial contributions to the total dosage.

The estimates of dosage to the whole body and bone via milk (Tables 7 and 8) should be compared with the corresponding estimates for the thyroid. For the adult thyroid the dosage estimate corresponding to the 4.6-rad whole-body dosage from ^{131}I is 2500 rads; the corresponding estimate from ^{133}I is 500 rads (assuming deposition occurs at 8 hr postdetonation).

Table 6
ESTIMATED PEAK CONCENTRATION IN MILK FROM
DEPOSITION OF SMALL PARTICLES (ACTIVATION
PRODUCTS ONLY)*

Radionuclide	f_M /liter/day†	C_M †	
		Fraction of I_0 per liter	$\mu\text{Ci/liter}$
^{22}Na	1.5 (-2)	4.5 (-3)	1.4 (-2)
^{24}Na	1.5 (-2)	1.9 (-4)	1.1 (2)
^{32}P	2.0 (-2)	1.3 (-2)	3.3 (0)
^{42}K	5.0 (-3)	2.8 (-4)	2.0 (1)
^{45}Ca	1.4 (-2)	1.1 (-2)	2.7 (-1)
^{47}Ca	1.4 (-2)	7.3 (-3)	1.3 (-1)
^{54}Mn	1.0 (-5)	1.0 (-5)	4.2 (-4)
^{55}Fe	4.0 (-5)	4.0 (-5)	3.6 (-3)
^{59}Fe	4.0 (-5)	4.0 (-5)	1.6 (-4)
^{57}Co	4.0 (-4)	4.0 (-4)	1.1 (-2)
^{58}Co	4.0 (-4)	4.0 (-4)	4.9 (-2)
^{60}Co	4.0 (-4)	4.0 (-4)	3.6 (-5)
^{65}Zn	1.0 (-2)	1.0 (-2)	9.0 (-3)
^{82}Br	1.1 (-2)	1.1 (-2)	7.4 (-1)
^{84}Rb	1.5 (-2)	8.4 (-3)	2.3 (-1)
^{86}Rb	1.5 (-2)	7.5 (-3)	1.0 (0)
^{110m}Ag	5.0 (-3)	5.0 (-3)	4.5 (4)
^{134}Cs	7.5 (-3)	4.7 (-3)	1.4 (-2)
^{237}U	1.5 (-4)	1.5 (-4)	1.8 (1)
^{239}Np	5.0 (-5)	5.0 (-5)	9.0 (1)

*Deposition is assumed to be 10^{-8} kt of neutron-activation products from fusion per square meter.

†The numerical value in parentheses signifies the exponential power of 10; thus 1.5 (-2) signifies 1.5×10^{-2} .

Plant-Herbivore-Meat Pathway

Since most of our cattle and sheep remain on pasture throughout the year, meat potentially could contribute relatively large quantities of nuclides to the diet following their deposition on vegetation. The plant-herbivore-meat model represents a preliminary attempt to evaluate the importance of meat contamination following the release of nuclides to the biosphere. In the model the fallout deposited on pasture is continuously ingested by grazing livestock and deposits in their muscle. The concentration of nuclides in the muscle of the 500-kg standard herbivore having a muscle mass of 200 kg was estimated from the daily rate of ingestion of contaminated vegetation and the turnover rate in muscle.

Table 7

ESTIMATED DOSAGE VIA MILK TO WHOLE BODY AND BONE
FROM FISSION PRODUCTS DEPOSITED AS SMALL PARTICLES

Radionuclide	Total activity ingested,*† μCi	Dose commitment,*‡ rads	
		Whole body	Bone
⁸⁹ Sr	6.5 (1)	0.56	4.4
⁹⁰ Sr	4.8 (-1)	0.70	5.7
⁹⁹ Mo	3.5 (2)	0.45	0.63
¹⁰³ Ru	1.6 (-1)	7 (-4)	1 (-3)
¹⁰⁶ Ru	1.2 (-2)	5 (-4)	1 (-3)
¹²⁵ Sn	4.8 (1)	0.028	0.13
¹²⁵ Sb	9.7 (-3)	4 (-6)	1 (-5)
^{129m} Te	3.0 (-1)	9 (-4)	1.4 (-3)
^{131m} Te	4.8 (0)	2 (-3)	2.3 (-3)
¹³² Te	4.1 (1)	0.054	0.06
¹³¹ I	1.3 (3)	4.6	2.4
¹³³ I	1.2 (3)	0.93	0.68
¹³⁶ Cs	3.5 (2)	5.9	5.9
¹³⁷ Cs	6.7 (0)	0.45	0.45
¹⁴⁰ Ba	8.1 (1)	0.13	0.95
¹⁴⁴ Ce	4.1 (-1)	1 (-5)	4 (-5)
	Total dose commitment	14	21

*The numerical value in parentheses signifies the exponential power of 10; thus 6.5 (1) signifies 6.5×10^1 .

†Values are based on a daily intake of 1 liter of milk having radionuclide concentrations as listed in Table 5.

‡Dose commitment is calculated as the 30-year dose to an adult (standard man).

For these estimates conservative but reasonable values were assumed for the fractional uptake to muscle by ingestion; these uptake values were estimated on the basis of experimental data from animals. The studies of Potter³⁹ and Chertok,⁴¹ as reported in this volume, were useful for this purpose. The biological half-life in muscle was then estimated from these fractional uptakes and from the stable-element concentrations in meat and forage plants as reported in the literature.⁶ Minor corrections were applied to the fractional uptakes and turnover rates on the basis of radionuclide burdens reported for animal muscle and vegetation.^{42,43} Details of this procedure will be reported subsequently. The fractional uptake and turnover rates of ⁹⁰Sr, ¹³¹I, and ¹³⁷Cs are comparable with previously assumed values.⁴⁴

Table 8
ESTIMATED DOSAGE VIA MILK TO WHOLE BODY AND BONE
FROM ACTIVATION PRODUCTS DEPOSITED AS SMALL PARTICLES

Radionuclide	Total activity ingested,*† μCi	Dose commitment,*‡ rads	
		Whole body	Bone
²² Na	3.1 (-1)	0.015	0.015
²⁴ Na	1.3 (2)	0.22	0.022
³² P	4.6 (1)	0.34	1.95
⁴² K	1.3 (1)	0.011	0.011
⁴⁵ Ca	5.9 (0)	0.053	0.52
⁴⁷ Ca	1.3 (0)	0.0042	0.041
⁵⁴ Mn	8.1 (-3)	1 (-5)	7 (-5)
⁵⁵ Fe	7.1 (-2)	2 (-5)	3 (-5)
⁵⁹ Fe	2.4 (-3)	9 (-6)	1 (-5)
⁵⁷ Co	2.1 (-1)	1 (-4)	9 (-5)
⁵⁸ Co	8.2 (-1)	0.003	0.002
⁶⁰ Co	7.2 (-4)	8 (-6)	6 (-6)
⁶⁵ Zn	1.7 (-1)	0.001	0.002
⁸² Br	1.4 (0)	0.003	0.003
⁸⁴ Rb	5.2 (0)	0.18	0.18
⁸⁶ Rb	2.1 (1)	0.24	0.24
^{110m} Ag	8.6 (-3)	7 (-4)	0.001
¹³⁴ Cs	4.5 (-1)	0.050	0.050
²³⁷ U	1.2 (2)	0.002	0.003
²³⁹ Np	2.6 (2)	2 (-5)	1 (-4)
Total dose commitment		1.1	3.0

*The numerical value in parentheses signifies the exponential power of 10; thus 8.1 (-1) signifies 8.1×10^{-1} .

†Values are based on a daily intake of 1 liter of milk having radionuclide concentrations as listed in Table 6.

‡Dose commitment is calculated as the 30-year dose to an adult (standard man).

Concentrations of Nuclides in Meat

Peak concentrations of nuclides in herbivore muscle were estimated assuming small-particle deposition. The standard herbivore, such as the cow, is assumed to utilize 45 m² of pasture daily and actually to consume daily the small particles deposited on 30 m² (initial retention factor, two-thirds). The half-residence time on forage is assumed to be 14 days.

Table 9 lists the estimated peak concentrations for fission products in herbivore muscle from the deposition of small particles, and Table 10 lists concentrations for activation products. The estimates are presented for nuclides

Table 9

ESTIMATED PEAK CONCENTRATION IN HERBIVORE MUSCLE
FROM DEPOSITION OF SMALL PARTICLES (FISSION PRODUCTS ONLY)*

Radionuclide	$C_{\text{meat}}^{\dagger}$		Ratio of C_{meat} to C_M , \ddagger ($\mu\text{Ci/kg}$)/($\mu\text{Ci/liter}$)
	($\mu\text{Ci/kg}$)/($\mu\text{Ci/m}^2$)	$\mu\text{Ci/kg}$	
^{89}Sr	4.9 (-3)	4.9 (-1)	0.2
^{90}Sr	5.3 (-3)	3.2 (-3)	0.2
^{103}Ru	1.4 (-2)	3.2 (0)	300
^{106}Ru	2.2 (-2)	3.0 (-1)	400
^{125}Sn	2.5 (-2)	4.4 (0)	0.9
^{125}Sb	6.8 (-3)	1.5 (-2)	30
$^{129\text{m}}\text{Te}$	2.1 (-2)	8.5 (-2)	6
^{131}I	3.2 (-2)	3.1 (1)	0.3
^{136}Cs	4.5 (-1)	6.0 (1)	3
^{137}Cs	1.1 (0)	1.0 (0)	5
^{140}Ba	5.3 (-4)	3.9 (-1)	0.08
^{144}Ce	2.2 (-3)	5.1 (-2)	2

*Deposition is assumed to be 10^{-8} kt of fission per square meter. \dagger The numerical value in parentheses signifies the exponential power of 10; thus 4.9 (-3) signifies 4.9×10^{-3} . \ddagger The peak concentrations in milk, C_M , are given in Table 5.

having half-lives greater than 7 days. The concentrations in muscle (C_{meat}) in microcuries per kilogram are presented both for unit deposition and for the 10^{-8} kt/m² hypothetical deposition. The last column of each table lists for each nuclide the ratio of peak concentration in meat to that in milk. Meat-to-milk ratios greater than 10 are noted for ^{103}Ru , ^{106}Ru , and ^{125}Sb (Table 9) and for ^{54}Mn , ^{55}Fe , and ^{59}Fe (Table 10). These nuclides were found earlier to be relatively unimportant via milk, but they could potentially represent a greater hazard via meat.

Estimated Dosage via Meat

Table 11 presents the dosage estimates for fission products via meat from the deposition of small particles and Table 12 the dosage estimates for activation products. We assumed for the estimates that the animal is slaughtered when the concentration in muscle is maximal and that meat consumption begins immediately and proceeds for a 6-month period at the rate of 300 g/day. Although these assumptions appear to be both overconservative and unrealistic, they serve to emphasize the relative unimportance of the meat pathway in comparison with the milk pathway.

Table 10

ESTIMATED PEAK CONCENTRATION IN HERBIVORE MUSCLE FROM DEPOSITION OF SMALL PARTICLES (ACTIVATION PRODUCTS ONLY)*

Radionuclide	$C_{\text{meat}}^{\dagger}$		Ratio of C_{meat} to C_M , \ddagger ($\mu\text{Ci/kg}$)/($\mu\text{Ci/liter}$)
	($\mu\text{Ci/kg}$)/($\mu\text{Ci/m}^2$)	$\mu\text{Ci/kg}$	
^{22}Na	1.0 (0)	6.1 (-2)	4
^{32}P	2.3 (-1)	1.3 (0)	0.4
^{45}Ca	5.7 (-2)	3.0 (-2)	0.1
^{54}Mn	1.6 (-2)	1.5 (-2)	40
^{55}Fe	3.5 (-2)	7.1 (-2)	20
^{59}Fe	2.1 (-2)	1.8 (-3)	10
^{57}Co	2.1 (-2)	1.3 (-2)	1
^{58}Co	1.7 (-2)	4.6 (-2)	1
^{60}Co	2.3 (-2)	4.6 (-5)	1
^{65}Zn	2.4 (-1)	4.7 (-3)	0.5
^{84}Rb	5.0 (-1)	3.0 (-1)	1
^{86}Rb	4.1 (-1)	1.2 (0)	1
$^{110\text{m}}\text{Ag}$	7.3 (-2)	1.5 (-4)	0.03
^{134}Cs	1.0 (0)	7.0 (-2)	5

*Deposition is assumed to be 10^{-8} kt of neutron-activation products from fusion per square meter.

\dagger The numerical value in parentheses signifies the exponential power of 10; thus 1.0 (0) signifies 1.0×10^0 .

\ddagger The peak concentrations in milk C_M are given in Table 6.

Table 11

ESTIMATED DOSAGE VIA MEAT TO WHOLE BODY AND BONE FROM FISSION PRODUCTS DEPOSITED AS SMALL PARTICLES

Radionuclide	Total activity ingested,* \dagger μCi	Dose commitment,* \ddagger rads	
		Whole body	Bone
^{89}Sr	2.4 (1)	0.087	0.67
^{90}Sr	4.5 (-1)	0.24	2.0
^{103}Ru	5.3 (1)	0.22	0.32
^{106}Ru	1.4 (1)	0.59	1.5
^{125}Sn	1.8 (1)	8 (-3)	0.036
^{125}Sb	7.6 (-1)	3 (-4)	9 (-4)
$^{129\text{m}}\text{Te}$	1.2 (0)	3.6 (-3)	5.5 (-3)
^{131}I	1.1 (2)	0.38	0.20
^{136}Cs	3.4 (2)	5.7	5.7
^{137}Cs	5.7 (1)	3.9	3.9
^{140}Ba	2.2 (0)	2.8 (-3)	0.021
^{144}Ce		6 (-5)	2 (-4)
Total dose commitment		11	14

*The numerical value in parentheses signifies the exponential power of 10; thus 2.4 (1) signifies 2.4×10^1 .

\dagger Values are based on a daily intake of 300 g for a 6-month period of meat having radionuclide concentrations as listed in Table 9.

\ddagger Dose commitment is calculated as the 30-year dose to an adult (standard man).

Table 12

ESTIMATED DOSAGE VIA MEAT TO WHOLE BODY AND BONE FROM
ACTIVATION PRODUCTS DEPOSITED AS SMALL PARTICLES

Radionuclide	Total activity ingested,*† μCi	Dose commitment,*‡ rads	
		Whole body	Bone
²² Na	3.1 (0)	0.057	0.057
³² P	7.8 (0)	0.058	0.33
⁴⁵ Ca	1.2 (0)	0.010	0.10
⁵⁴ Mn	6.7 (-1)	1.2 (-3)	5.5 (-3)
⁵⁵ Fe	3.6 (0)	1.1 (-3)	1.7 (-3)
⁵⁹ Fe	3.3 (-2)	1 (-4)	1 (-4)
⁵⁷ Co	5.5 (-1)	3 (-4)	3 (-4)
⁵⁸ Co	1.2 (0)	4.1 (-3)	3 (-3)
⁶⁰ Co	2.4 (-3)	3 (-5)	2 (-5)
⁶⁵ Zn	2.0 (-1)	1.3 (-3)	2.3 (-3)
⁸⁴ Rb	4.2 (0)	0.14	0.14
⁸⁶ Rb	1.0 (1)	0.11	0.11
^{110m} Ag	6.3 (-3)	5 (-4)	8 (-4)
¹³⁴ Cs	3.5 (0)	0.40	0.40
Total dose commitment		0.78	1.2

*The numerical value in parentheses signifies the exponential power of 10; thus 3.1 (0) signifies 3.1×10^0 .

†Values are based on a daily intake of 300 g for a 6-month period of meat having radionuclide concentrations as listed in Table 10.

‡Dose commitment is calculated as the 30-year dose to an adult (standard man).

The nuclides that could contribute most to the dose commitments via meat include some of those previously singled out in the discussion of the milk pathway: ⁸⁹Sr, ⁹⁰Sr, ¹³¹I, ¹³⁶Cs, and ¹³⁷Cs (Table 11) and ²²Na, ³²P, ⁴⁵Ca, ⁸⁴Rb, ⁸⁶Rb, and ¹³⁴Cs (Table 12). Of the nuclides having meat-to-milk concentration ratios greater than 10, only ¹⁰³Ru and ¹⁰⁶Ru could contribute substantially to the dose commitment. The input parameters required in the plant-herbivore-meat model for isotopes of ruthenium cannot be regarded as being firmly established. Activation products of device origin do not contribute appreciably to the dose commitments via meat. The estimates of dosage to the whole body and bone should be compared with the corresponding estimate for the thyroid from ¹³¹I, a dosage of 200 rads.

Estimated Dosage from Deposition of Large Particles

Tables 13 and 14 present the dosage estimates for fission products and for activation products, respectively, via milk and meat from the deposition of large

Table 13
ESTIMATED DOSAGE TO WHOLE BODY AND BONE FROM FISSION
PRODUCTS DEPOSITED AS LARGE PARTICLES

Radionuclide	Dose commitment, rads*†			
	Via milk‡		Via meat§	
	Whole body	Bone	Whole body	Bone
⁸⁹ Sr	0.038	0.29	0.013	0.10
⁹⁰ Sr	0.040	0.33	0.036	0.29
⁹⁹ Mo	0.064	0.089		
¹⁰³ Ru	5 (-5)	7 (-5)	0.021	0.030
¹⁰⁶ Ru	3 (-5)	8 (-5)	0.044	0.11
¹²⁵ Sn	0.007	0.032	0.001	0.005
¹²⁵ Sb	2 (-7)	6 (-7)	2 (-5)	6 (-5)
^{129m} Te	6 (-6)	1 (-4)	4 (-4)	6 (-4)
^{131m} Te	3.7 (-4)	4 (-4)		
¹³² Te	0.007	0.008		
¹³¹ I	0.48	0.25	0.053	0.028
¹³³ I	0.16	0.12		
¹³⁶ Cs	0.54	0.54	0.71	0.71
¹³⁷ Cs	0.026	0.026	0.32	0.32
¹⁴⁰ Ba	0.010	0.074	3 (-4)	0.003
¹⁴⁴ Ce	6 (-7)	3 (-6)	4 (-6)	2 (-5)
Total dose commitment	1.4	1.8	1.2	1.6

*The numerical value in parentheses signifies the exponential power of 10; thus 5 (-5) signifies 5×10^{-5} .

†Dose commitment is calculated as the 30-year dose to an adult (standard man).

‡Values are based on a daily milk intake of 1 liter.

§Values are based on a daily meat intake of 300 g for a 6-month period.

particles. Please recall that these estimates were made by assuming an initial retention of 13% and a half-residence time on forage of 4 days. In other respects the dosage estimates were made in the same manner as those from deposition of small particles.

Summary of Dosage Estimates

Table 15 summarizes the dosage estimates from deposition of small and large particles via milk, and Table 16 summarizes those via meat. For both routes and both kinds of deposition, the dose to the thyroid from iodine isotopes is the highest of all doses listed. The thyroid doses via milk exceed the total doses to whole body and bone by two orders of magnitude and via meat by one order of magnitude. The dosages from fission products exceed the dosages from

Table 14
ESTIMATED DOSAGE TO WHOLE BODY AND BONE FROM
ACTIVATION PRODUCTS DEPOSITED AS LARGE PARTICLES

Radionuclide	Dose commitment, mrad*†			
	Via milk‡		Via meat§	
	Whole body	Bone	Whole body	Bone
²² Na	0.86	0.86	4.5	4.5
²⁴ Na	41	41		
³² P	30	170	6.9	39
⁴² K	2.1	2.1		
⁴⁵ Ca	3.2	32	0.93	9.1
⁴⁷ Ca	0.52	5.1		
⁵⁴ Mn	8 (-4)	4 (-3)	0.11	0.53
⁵⁵ Fe	1 (-3)	2 (-3)	0.074	0.11
⁵⁹ Fe	6 (-4)	7 (-4)	0.011	0.012
⁵⁷ Co	8 (-3)	6 (-3)	0.027	0.020
⁵⁸ Co	0.19	0.14	0.35	0.26
⁶⁰ Co	5 (-4)	4 (-4)	0.002	0.001
⁶⁵ Zn	0.07	0.12	0.10	0.18
⁸² Br	0.55	0.55		
⁸⁴ Rb	12	12	16	16
⁸⁶ Rb	20	20	14	14
^{110m} Ag	0.04	0.06	0.04	0.06
¹³⁴ Cs	3.0	3.0	34	34
²³⁷ U	0.27	0.33		
²³⁹ Np	3 (-3)	2 (-3)		
Total dose commitment	110	290	77	120

*The numerical value in parentheses signifies the exponential power of 10; thus 8 (-4) signifies 8×10^{-4} .

†Dose commitment is calculated as the 30-year dose to an adult (standard man).

‡Values are based on a daily milk intake of 1 liter.

§Values are based on a daily meat intake of 300 g for a 6-month period.

Table 15

SUMMARY OF SOURCE CONTRIBUTIONS TO THE ESTIMATED DOSAGE
VIA MILK FROM DEPOSITION OF SMALL AND LARGE PARTICLES*

Source	Small particles, rads			Large particles, rads		
	Whole body	Bone	Thyroid	Whole body	Bone	Thyroid
Fission	14	21	3000†	1.4	1.8	340†
Neutron activation	1.1	3		0.11	0.29	
Total	15	24		1.5	2.1	

*This table summarizes the dosage estimates of Tables 7, 8, 13, and 14.

†The thyroid dosage is attributed to ^{131}I and ^{133}I .

Table 16

SUMMARY OF SOURCE CONTRIBUTIONS TO THE ESTIMATED DOSAGE
VIA MEAT FROM DEPOSITION OF SMALL AND LARGE PARTICLES*

Source	Small particles, rads			Large particles, rads		
	Whole body	Bone	Thyroid	Whole body	Bone	Thyroid
Fission	11	14	200†	1.2	1.6	28†
Neutron activation	0.78	1.2		0.077	0.12	
Total	12	15		1.3	1.7	

*This table summarizes the dosage estimates of Tables 11, 12, 13, and 14.

†The thyroid dosage is attributed to ^{131}I .

activation products by about an order of magnitude. Most of the dose commitment from activation products is attributable to nuclides derived from rock and soil. The total doses to the whole body and bone are about the same via milk and via meat. In view of the overconservative and unrealistic assumptions involved in making the dosage estimates via meat, this similarity serves to emphasize the much greater importance of the milk pathway following single depositions on vegetation. The thyroid dose from iodine isotopes via milk exceeds that via meat by an order of magnitude; this further emphasizes the importance of the milk pathway. When we consider the dose commitment to a child, the importance of the milk pathway is magnified still further. For both pathways the dosage estimate for a child's thyroid would be higher by about a factor of 10 than that shown in Tables 15 and 16 for an adult. However, a child

is likely to consume a liter of milk daily but would be likely to consume meat at a much lower rate than 300 g/day.

The estimates of dosage from large-particle deposition are almost uniformly one-tenth those from small-particle deposition. The differences would be greater if we assumed a retention factor less than 13% and/or a half-residence time on forage less than 4 days.

Uncertainties in the Estimates

Some of the uncertainties in predicting food contamination and dosage relate to the assumptions adopted. In the estimates of milk contamination, we assumed that cows are continuously grazing on pasture. If cows were feeding on stored feed collected before the deposition of fallout, milk contamination could be expected to be lower by one to two orders of magnitude. Similarly, our assumption that milk consumption begins immediately with no delay for processing and handling leads to estimates that are overconservative for the particularly short-lived nuclides such as ^{99}Mo , $^{131\text{m}}\text{Te}$, ^{133}I , ^{24}Na , ^{42}K , and ^{82}Br . The dosages would also be lower if milk consumption were delayed.

The same considerations apply to the estimates via the meat pathway, where delays associated with processing and handling would be greater. As we have pointed out, the conservative, unrealistic assumptions adopted for the meat pathway serve to emphasize the much greater importance of the milk pathway following single depositions of radionuclides on vegetation.

Additional uncertainties in the predictions are attributable to uncertainties in the transport and interaction terms. We have assumed unfractionated deposition of nuclides. Among the nuclides that were shown to make important contributions to the dosage are ^{89}Sr , ^{90}Sr , ^{137}Cs , and ^{140}Ba , which have rare-gas precursors. We can reasonably expect that nuclides with rare-gas precursors would be distributed to a greater extent on the smaller particles. Consequently food contamination and dosage from large particles may be overestimated, whereas those from small particles may be underestimated. The actual differences between the dosage estimates from small and large particles would then be greater than those shown in Tables 15 and 16.

The actual extent of food contamination by the other important nuclides singled out (^{99}Mo , ^{131}I , ^{136}Cs , ^{22}Na , ^{24}Na , ^{32}P , ^{45}Ca , ^{84}Rb , ^{86}Rb , and ^{134}Cs) depends similarly on their partitioning between small- and large-particle fractions. Most of these nuclides would be expected to exhibit intermediate behavior with respect to fractionation. The refractory nuclide ^{99}Mo , which would contribute to the dosage via milk at early times, could be expected to be distributed to a greater extent in the larger particles.

The major uncertainty in the interaction term is the biological availability of the nuclide in fallout, which depends in turn on the partitioning of the nuclide between small- and large-particle fractions. The biological availabilities of ^{22}Na , ^{89}Sr , ^{90}Sr , ^{99}Mo , ^{131}I , ^{133}I , ^{134}Cs , ^{137}Cs , and ^{140}Ba in small-particle debris

($\leq 50 \mu$) with respect to milk secretion have been found to be comparable to those of tracers used in experiments within a factor of 2 or 3. The biological availabilities of ^{24}Na , ^{32}P , ^{45}Ca , ^{47}Ca , ^{84}Rb , ^{86}Rb , and ^{136}Cs have not been determined. The biological availabilities of some nuclides in large particles may be less than in small particles by virtue of differences in physical state, which would lead to lower estimates from large-particle deposition.

PREDICTION OF THE INTERNAL DOSAGE FROM LONG-TERM DEPOSITION BASED ON CHRONIC-CONTAMINATION MODEL

It is estimated that a land-surface burst in the 1-Mt range would inject about 50% of its radioactivity into the stratosphere.^{2,9} Therefore we shall assume that 50% of the nuclides produced would enter the stratosphere and be deposited as long-term fallout. At the same time we can reasonably assume an equivalent injection into the stratosphere originating from retaliatory detonations initiated by friendly forces. On this basis we have simply assumed that all the activity produced would be injected into the stratosphere, as would be the case for airbursts involving weapons of the size assumed.

Air Concentrations and Rate of Deposition of Nuclides

The estimated rate of deposition of nuclides from the stratosphere is based on Peterson's empirical model for estimating worldwide deposition from nuclear debris injected into the stratosphere.^{2,9} According to this model the maximum annual surface deposition of ^{90}Sr in the 30 to 50° N latitude band for a 1-MCi injection into the lower polar stratosphere (9 to 17 km altitude) would be expected to vary between 250 and 400 kCi. For a 1-MCi injection into the upper polar stratosphere (17 to 50 km altitude), the maximum annual deposition could be expected to vary between 50 and 170 kCi. The cloud from a 1-Mt burst in the latitude band 30 to 90° N can be expected to stabilize in the lower polar stratosphere, whereas a 10-Mt burst in this region can be expected to stabilize in the upper polar stratosphere. Accordingly we have based our estimates on an intermediate value of 200 kCi of ^{90}Sr deposited in one year in the 30 to 50° N latitude band per megacurie injected into the stratosphere. It can be readily shown that an annual deposition of 1 kCi in the 30 to 50° N latitude band is equivalent to a deposition rate of $1.7 \times 10^{-9} \mu\text{Ci}/\text{m}^2/\text{hr}$.

An apparent deposition velocity of 40 m/hr has been determined empirically from the observed monthly deposition rates and average surface-air concentrations of ^{90}Sr in the Northern Hemisphere.^{4,5} An apparent deposition velocity of 40 m/hr has also been determined on the basis of quarterly deposition rates and average surface-air concentrations from U. S. stations alone.^{4,6} A deposition velocity of 40 m/hr, together with these assumptions regarding the deposition rate of stratospheric debris, leads to an estimate of $8.5 \times 10^{-9} \mu\text{Ci}/\text{m}^3$ for the average concentration of ^{90}Sr in surface air during any 12-month period closely

following the injection of 1 MCi into the stratosphere. For present purposes we can simply round this off to $1 \times 10^{-8} \mu\text{Ci}/\text{m}^3$, which is the value we have assumed for all the nuclides of interest.

The assumption that $10^{-8} \mu\text{Ci}/\text{m}^3$ is the average surface-air concentration in the 30 to 50° N latitude band following the injection of 1 MCi into the stratosphere is consistent with measurements reported by Thomas et al.¹⁴ Table 17 shows ground-level air concentrations measured at Richland, Wash. (46° N). The table compares the spring concentration maxima measured in 1963

Table 17
RELATION BETWEEN GROUND-LEVEL AIR CONCENTRATION AND
STRATOSPHERIC BURDEN AT RICHLAND, WASH. (46° N), IN 1963¹⁴

Nuclide	Spring concentration maxima		Stratospheric burden, MCi	Ratio, $\frac{\mu\text{Ci}/\text{m}^3}{\text{MCi}}$
	dis/min/ 10^6 ft^3	$\mu\text{Ci}/\text{m}^3$		
⁵⁴ Mn	1.4×10^4	2.2×10^{-7}	5.7×10^1	3.9×10^{-9}
¹⁰⁶ Ru	7.0×10^4	1.1×10^{-6}	2.1×10^2	5.3×10^{-9}
¹²⁵ Sb	9.0×10^3	1.4×10^{-7}	3.3×10^1	4.4×10^{-9}
¹³⁷ Cs	7.5×10^3	1.2×10^{-7}	1.5×10^1	8.2×10^{-9}
¹⁴⁴ Ce	1.0×10^5	1.6×10^{-6}	3.6×10^2	4.5×10^{-9}

with the megacuries injected into the stratosphere in the 1961–1962 series. As mentioned previously, the total fission yield of the 1961–1962 atmospheric detonations was about 100 Mt. The ratio between the air concentration in microcuries per cubic meter and the stratospheric burden in megacuries varied between 4×10^{-9} and 8×10^{-9} ; if the ratio were calculated with the average concentration for the year, it would of course be smaller. A large fraction of the stratospheric burden from the 1961–1962 test series was injected into the upper stratospheric compartment. By assuming a higher value of 10^{-8} for the ratio of air concentration to stratospheric burden, we allow for injections into the lower stratospheric compartment, from which initial deposition rates will be greater.

Deposition of Nuclides on Vegetation

To estimate the dosage that could result from the continuous deposition of radionuclides on vegetation, we estimated the steady-state deposition of particles on forage, F_{eq} , as the quotient of the deposition rate, R , and the rate of loss by weathering, λ_M :

$$F_{\text{eq}} = \frac{R}{\lambda_M} \quad (3)$$

Since the deposition rate, R , is related to the air concentration, L , by the deposition velocity, V_g ,

$$R = V_g L \quad (4)$$

the equilibrium deposition on forage can be expressed in terms of the air concentration:

$$F_{eq} = \frac{V_g L}{\lambda_M} \quad (5)$$

The food contamination and dosage from the continuous deposition of nuclides from the stratosphere were estimated from equilibrium depositions, F_{eq} , determined as outlined previously. The deposition velocity, V_g , was assumed to be 40 m/hr, and the rate of loss by weathering, λ_M , was assumed to be 0.05 per day, which is equivalent to a half-residence time on forage of 14 days.

Forage-Cow-Milk Pathway

The forage-cow-milk model, as previously described for small particles, assumes a UAF of 45 m²/day and an initial retention factor of two-thirds.

Concentrations of Nuclides in Milk

Table 18 lists the estimated average concentrations for fission products in milk from stratospheric deposition during a year closely following the

Table 18
ESTIMATED AVERAGE CONCENTRATIONS IN MILK AND MEAT FROM
THE STRATOSPHERIC DEPOSITION DURING A YEAR CLOSELY
FOLLOWING THE HYPOTHETICAL ATTACK (FISSION PRODUCTS ONLY)

Radionuclide	C_M^*		C_{meat}^*		Ratio of C_{meat} to C_M
	$\frac{\mu\text{Ci/liter}}{\mu\text{Ci/m}^3}$	$\mu\text{Ci/liter}$	$\frac{\mu\text{Ci/kg}}{\mu\text{Ci/m}^3}$	$\mu\text{Ci/kg}$	
⁸⁹ Sr	3.9 (2)	1.2 (-3)	6.4 (1)	1.9 (-4)	0.2
⁹⁰ Sr	4.9 (2)	8.6 (-4)	8.3 (1)	1.5 (-4)	0.2
¹⁰⁶ Ru	5.3 (-1)	1.1 (-5)	1.8 (3)	3.8 (-2)	3000
¹²⁵ Sb	2.7 (0)	1.4 (-5)	3.5 (3)	1.8 (-2)	1000
¹³⁷ Cs	4.1 (3)	1.2 (-2)	4.7 (4)	1.4 (-1)	10
¹⁴⁴ Ce	1.0 (1)	3.0 (-4)	3.7 (2)	1.1 (-2)	30

*The numerical value in parentheses signifies the exponential power of 10; thus 3.9 (2) signifies 3.9×10^2 .

hypothetical attack. Table 19 gives the estimates for activation products. The nuclides listed are those having half-lives greater than 45 days. The concentrations are both for unit air concentration and for the estimated average concentration for the year.

Table 19

ESTIMATED AVERAGE CONCENTRATIONS IN MILK AND MEAT FROM
THE STRATOSPHERIC DEPOSITION DURING A YEAR CLOSELY
FOLLOWING THE HYPOTHETICAL ATTACK (ACTIVATION PRODUCTS ONLY)

Radionuclide	C_M^*		C_{meat}^*		Ratio of C_{meat} to C_M
	$\frac{\mu\text{Ci/liter}}{\mu\text{Ci/m}^3}$	$\mu\text{Ci/liter}$	$\frac{\mu\text{Ci/kg}}{\mu\text{Ci/m}^3}$	$\mu\text{Ci/kg}$	
^{22}Na	8.1 (3)	1.3 (-3)	6.2 (4)	8.7 (-3)	7
^{45}Ca	7.1 (3)	2.3 (-3)	2.2 (3)	7.1 (-4)	0.3
^{54}Mn	5.3 (0)	6.3 (-6)	5.0 (2)	6.0 (-4)	100
^{55}Fe	2.2 (1)	9.9 (-5)	6.1 (3)	2.8 (-2)	300
^{57}Co	2.1 (2)	1.5 (-4)	1.4 (3)	1.0 (-3)	7
^{58}Co	1.8 (2)	4.4 (-5)	8.4 (2)	2.0 (-4)	4
^{60}Co	2.2 (2)	1.2 (-5)	1.8 (3)	9.6 (-6)	0.8
^{65}Zn	5.2 (3)	1.1 (-4)	1.6 (4)	3.5 (-4)	3
^{110m}Ag	2.6 (3)	5.7 (-6)	6.4 (3)	1.4 (-5)	2
^{134}Cs	4.0 (3)	5.6 (-4)	4.5 (4)	6.3 (-3)	10

*The numerical value in parentheses signifies the exponential power of 10; thus 8.1 (3) signifies 8.1×10^3 .

Estimated Dosage via Milk

Tables 20 and 21 present estimates of the average dose rate via milk to adult whole body and bone from the nuclides depositing from the stratosphere during a year closely following the hypothetical attack. Fission products are considered in Table 20 and activation products in Table 21. The rates of ingestion were calculated assuming milk consumption of 1 liter/day. The dose rates to whole body and bone assume that the concentration of the nuclide in tissue has reached a steady state with respect to the constant rate of ingestion.* The total dose rate from fission products (Table 20) is about 1 rad/year in the whole body and about 6 rads/year in bone. It comes as no surprise that ^{90}Sr , ^{137}Cs , and, to a lesser extent, ^{89}Sr , contribute most to the dose rate from fission products.

*The dose commitment (rads) from a given nuclide would be estimated as the product of the dose rate (rads/year) and the mean residence time of the nuclide in the stratosphere (year).

Table 20

ESTIMATED AVERAGE DOSE RATE VIA MILK TO WHOLE BODY AND BONE
FROM FISSION PRODUCTS DEPOSITING FROM THE STRATOSPHERE
DURING A YEAR CLOSELY FOLLOWING THE HYPOTHETICAL ATTACK

Radionuclide	Rate of ingestion,* $\mu\text{Ci/year}$	Dose rate,* rads/year	
		Whole body	Bone
^{89}Sr	4.2 (-1)	3.6 (-3)	0.028
^{90}Sr	3.2 (-1)	0.62	5.4
^{106}Ru	4.1 (-3)	1 (-4)	4 (-4)
^{125}Sb	4.9 (-3)	2 (-6)	5 (-6)
^{137}Cs	4.4 (0)	0.29	0.29
^{144}Ce	1.1 (-1)	3 (-6)	1 (-5)
Total dose rate		0.91	5.7

*The numerical value in parentheses signifies the exponential power of 10; thus 4.2 (-1) signifies 4.2×10^{-1} .

Table 21

ESTIMATED AVERAGE DOSE RATE VIA MILK TO WHOLE BODY AND BONE
FROM ACTIVATION PRODUCTS DEPOSITING FROM THE STRATOSPHERE
DURING A YEAR CLOSELY FOLLOWING THE HYPOTHETICAL ATTACK

Radionuclide	Rate of ingestion,* $\mu\text{Ci/year}$	Dose rate,* mrad/year	
		Whole body	Bone
^{22}Na	4.1 (-1)	7.6	7.6
^{45}Ca	8.2 (-1)	7.2	7.2
^{54}Mn	2.3 (-3)	4 (-3)	2 (-2)
^{55}Fe	3.6 (-2)	1 (-2)	2 (-2)
^{57}Co	5.3 (-2)	3 (-2)	2 (-2)
^{58}Co	1.6 (-2)	6 (-2)	5 (-2)
^{60}Co	4.2 (-4)	5 (-3)	3 (-3)
^{65}Zn	4.2 (-2)	0.3	0.47
$^{110\text{m}}\text{Ag}$	2.1 (-3)	0.16	0.26
^{134}Cs	2.1 (-1)	23	23
Total dose rate		38	100

*The numerical value in parentheses signifies the exponential power of 10; thus 4.1 (-1) signifies 4.1×10^{-1} .

A comparison of Tables 20 and 21 reveals that the dose rate to the whole body from fission products would exceed that from activation products by about a factor of 20; the dose rate to bone from fission products would exceed that from activation products by about a factor of 50. The activation products of Table 21 which would contribute most to the dosage via milk are the neutron-activation products of soil and rock, ^{22}Na , ^{45}Ca , and ^{134}Cs . The dose rates listed in Table 21 are expressed in millirad units. Activation products of device origin would contribute relatively little to the total dose rate.

Plant—Herbivore—Meat Pathway

The estimates via meat, like those via milk, were made as previously described for small particles, assuming a UAF of $45\text{ m}^2/\text{day}$ and an initial retention factor of two-thirds.

Concentration of Nuclides in Meat

Tables 18 (for fission products) and 19 (for activation products) list the estimated average concentrations in meat from stratospheric deposition during a year closely following the hypothetical attack. The nuclides listed have half-lives greater than 45 days. The concentrations are both for unit air concentration and for the estimated average concentration for the year. The meat-to-milk ratios of average concentrations, given in the last column of these tables, suggest that, except for isotopes of calcium and strontium, the nuclide concentrations in meat would be about the same as, or greater than, those in milk. According to these calculations, the average concentration of ^{106}Ru and ^{125}Sb in meat would exceed their average concentration in milk by three orders of magnitude. The average concentration of ^{55}Fe in meat would exceed its average concentration in milk by more than a factor of 100.

Estimated Dosage via Meat

Tables 22 and 23 present the estimates of the average dose rate via meat to the adult whole body and bone from the nuclides depositing from the stratosphere during a year closely following the hypothetical attack. Fission products are considered in Table 22 and activation products in Table 23. The rate of ingestion was calculated assuming meat consumption at the rate of 300 g/day. Again ^{90}Sr and ^{137}Cs make major contributions to the total dose rate via meat; in addition, ^{106}Ru makes a substantial contribution. As mentioned earlier, the input parameters required for ruthenium isotopes via this pathway are open to question. The dose rate to the whole body from fission products via meat totals 1.2 rads/year, whereas that to bone totals 1.8 rads/year. The dose estimates from activation products are again less by about an order of magnitude. The neutron-activation products singled out in Table 23 include ^{22}Na , ^{45}Ca , and ^{134}Cs , the same nuclides of environmental origin previously

Table 22

ESTIMATED AVERAGE DOSE RATE VIA MEAT TO WHOLE BODY AND BONE FROM FISSION PRODUCTS DEPOSITING FROM THE STRATOSPHERE DURING A YEAR CLOSELY FOLLOWING THE HYPOTHETICAL ATTACK

Radionuclide	Rate of ingestion,* $\mu\text{Ci/year}$	Dose rate,* rads/year	
		Whole body	Bone
^{89}Sr	2.1 (-2)	1.8 (-4)	1.4 (-3)
^{90}Sr	1.6 (-2)	0.03	0.27
^{106}Ru	4.2 (0)	0.12	0.45
^{125}Sb	2.0 (0)	8 (-4)	2 (-3)
^{137}Cs	1.5 (1)	1.0	1.0
^{144}Ce	1.2 (0)	3 (-5)	1 (-4)
	Total dose rate	1.2	1.8

*The numerical value in parentheses signifies the exponential power of 10; thus 2.1 (-2) signifies 2.1×10^{-2} .

Table 23

ESTIMATED AVERAGE DOSE RATE VIA MEAT TO WHOLE BODY AND BONE FROM ACTIVATION PRODUCTS DEPOSITING FROM THE STRATOSPHERE DURING A YEAR CLOSELY FOLLOWING THE HYPOTHETICAL ATTACK

Radionuclide	Rate of ingestion,* $\mu\text{Ci/year}$	Dose rate,* mrad/year	
		Whole body	Bone
^{22}Na	9.6 (-1)	17	17
^{45}Ca	7.8 (-2)	0.68	6.8
^{54}Mn	6.6 (-2)	0.11	0.5
^{55}Fe	3.1 (0)	0.93	1.4
^{57}Co	1.1 (-1)	0.07	0.05
^{58}Co	2.2 (-2)	0.08	0.06
^{60}Co	1.1 (-3)	0.01	0.01
^{65}Zn	3.8 (-2)	0.25	0.43
$^{110\text{m}}\text{Ag}$	1.6 (-3)	0.1	0.2
^{134}Cs	6.9 (-1)	77	77
	Total dose rate	96	100

*The numerical value in parentheses signifies the exponential power of 10; thus 9.6 (-1) signifies 9.6×10^{-1} .

singled out via milk. In addition, ^{55}Fe , of device origin, would make a small contribution.

Summary of Dosage Estimates

Table 24 summarizes the dosage estimates from stratospheric deposition. The table shows the dominant role of fission products, whose contributions to the dosage exceed those of activation products by more than a factor of 10. The

Table 24

SUMMARY OF SOURCE CONTRIBUTIONS TO THE ESTIMATED AVERAGE DOSE RATES VIA MILK AND MEAT FROM STRATOSPHERIC DEPOSITION DURING A YEAR CLOSELY FOLLOWING THE HYPOTHETICAL ATTACK

Source	Milk pathway, rads/year		Meat pathway, rads/year	
	Whole body	Bone	Whole body	Bone
Fission	0.91	5.7	1.2	1.8
Neutron activation	0.038	0.10	0.096	0.10
Total	0.95	5.8	1.3	1.9

table also shows that the dose rates via the two routes (via milk and via meat) would not differ greatly. Thus, for continuous deposition extending in time, the meat and milk pathways would be more comparable in importance. For the single discrete depositions previously considered, the milk pathway assumes a far greater importance.

Interpretations of the Estimates

Before discussing the dosage estimates from nuclides initially depositing from the stratosphere, let us consider briefly the validity of the model for chronic contamination. This model involves the derivation of a proportionality factor between the average nuclide concentration in milk or meat and the average nuclide concentration in surface air. The relation of air concentration of a nuclide to food contamination obviously involves factors relating to plant-retention characteristics, the local environment, and agricultural feeding practices. Wilson⁴⁷ developed an ecologically based quantitative model of the transport of ^{137}Cs from fallout to milk. This model can predict to a high degree of precision the mean quarterly levels of ^{137}Cs in milk from the mean surface concentrations in air. The linear correlation between mean quarterly ^{137}Cs levels in milk and mean surface-air concentrations during the growing season for

various milksheds across the nation was characterized by a value of 710 pCi/liter in milk per picocurie per cubic meter in surface air. This particular correlation was associated with dry-lot feeding. The Seattle milkshed exhibited a different correlation, which by our calculations is characterized by a value of 4100 pCi/liter in milk per picocurie per cubic meter in surface air. The response of the Seattle milkshed was thought to be characteristic of pasture feeding. Our model assumes that the animals providing the milk and the meat are continuously on pasture. The ^{137}Cs concentration in milk listed in Table 18 is equivalent to 4100 pCi/liter per picocurie per cubic meter in surface air. This close correspondence to the Seattle value obtained by Wilson is, of course, fortuitous. An inspection of milk concentrations and surface-air concentrations of ^{137}Cs and ^{90}Sr measured from the middle of 1963 at Ispra, Italy (as reported in the HASL series of reports from the Health and Safety Laboratory, U. S. Atomic Energy Commission⁴⁸), indicates that the correlation between ^{137}Cs concentrations in milk and air would be about $5200 (\text{pCi/liter})/(\text{pCi/m}^3)$. For ^{90}Sr the correlation at Ispra would be about $960 (\text{pCi/liter})/(\text{pCi/m}^3)$. When the concentrations of ^{90}Sr in milk from the Seattle milkshed⁴⁹ were compared with the surface-air levels over Seattle,⁴⁸ the correlation was estimated to be $620 (\mu\text{Ci/liter})/(\mu\text{Ci/m}^3)$. The concentration of ^{90}Sr listed in Table 18 is $490 (\mu\text{Ci/liter})/(\mu\text{Ci/m}^3)$. If we assume that pasture feeding was the dominant practice at Ispra and Seattle, the values listed in Table 18 for the concentrations of ^{137}Cs and ^{90}Sr in milk appear to be reasonable.

Since field data on concentrations of nuclides in meat are far less abundant than those in milk, particularly for ^{90}Sr , we simply compared the predicted and observed ratios of the concentration in meat to that in milk. The concentration of stable strontium per gram of calcium in meat is about twice that in milk.⁵⁰ The concentration of ^{90}Sr per gram of calcium in meat also was found to be twice that in milk in the United Kingdom diet of 1963 and 1964 (Refs. 51 and 52). On the basis of the stable calcium content of milk and meat (1.3 g Ca/liter and 0.1 g Ca/kg, respectively⁶), the ratio of the average concentration of ^{90}Sr in meat to that in milk could be expected to be 0.15. (We assumed that the ^{90}Sr burdens of 1963 and 1964 are largely attributed to direct contamination.) The ratio can be expected to vary with geographical location. Thus the ratio of the average yearly concentration of ^{90}Sr in meat to that in milk in the Danish diet from 1962 to 1964 varied from 0.20 to 0.26 (Refs. 53–55). After examining the tri-city data on ^{90}Sr concentration in foods from 1962 to 1964 (from the HASL reports⁴⁸), we estimated the increments of the burdens that were associated with recent deposition. The estimated ratio of the average concentration of ^{90}Sr attributable to direct contamination in meat to that in milk was about 0.11 to 0.14 in the San Francisco and Chicago diets. The concentration of ^{90}Sr reported for meat in the New York diet was relatively insensitive to fresh contamination, and the meat-to-milk ratio was less than 0.05. The ratio listed in Table 18, 0.2, is within the range reported.

Meat and milk together have been the main dietary sources of ^{137}Cs . The concentration of ^{137}Cs in meat could be expected to exceed that in milk; e.g., the correlation between the ^{137}Cs contents in beef and milk in Sweden from 1962 to 1966 is characterized by a concentration ratio (picocurie per kilogram of meat to picocurie per liter of milk) averaging 4.3 (Ref. 56). The ratio of the average yearly concentration of ^{137}Cs in meat to that in milk in the United Kingdom from 1961 to 1964 varied from 3.2 to 5.3 (Ref. 52). The ratio in Denmark was 5.8 in 1963 (Ref. 54) and 5.3 in 1964 (Ref. 55). The meat-to-milk ratio of ^{137}Cs listed in Table 18 is 10. The predicted concentration of ^{90}Sr and ^{137}Cs in meat appears to be acceptable in view of the wide variation that could be expected. Thus the average concentration of ^{137}Cs in beef sampled at various slaughterhouses in Norway from 1965 to 1967, ranged from 120 to 1700 pCi/kg (Ref. 57). The average concentration in mutton ranged from 520 to 4800 pCi/kg. This variation points out the important role of differences in local environmental factors and feeding practices.

Let us now consider the dosage estimates presented in Tables 20 and 23 for the nuclides depositing from the stratosphere. If both the concentrations of the nuclides in milk and meat and the ingestion rates were as we have supposed, we could accept these estimates at face value. The dose rates shown in these tables for the year closely following the initial injection of the nuclides into the stratosphere, combined with the decreasing dose rates that would be associated with nuclide deposition in succeeding years, would constitute a long-term internal dose commitment. This dose commitment would make a substantial contribution to the dose commitment for the individual who was adequately protected from the gamma field in the few weeks immediately following an attack and who also avoided contaminated foods during this period.

It is interesting to compare the estimated yearly dose rates from fission products via milk (Table 20) with the corresponding estimated doses from local and tropospheric deposition at early times (Table 7). The total yearly dose rate to the whole body and bone from stratospheric deposition is somewhat less than the total dose commitment to these organs from the 10^{-8} kt/m² deposition at early times. However, the yearly dose rate from stratospheric deposition, which is attributable to ^{90}Sr and ^{137}Cs , is comparable to the dose from the early deposition of these nuclides. This simple comparison points out the significance of the stratospheric compartments for these long-lived nuclides. The initial deposition rate from the stratosphere, and hence the initial average dose rate, may be either greater or less than our estimate. But, since the residence time of stratospheric debris is measured in months or years rather than in decades, essentially all the stratospheric burden of ^{90}Sr and ^{137}Cs would reach ground level where it could then contribute to the internal dose commitment before radioactive decay.

It is also interesting to compare the external and internal dosages that would be associated with long-term deposition. The internal and external dosages

resulting from ^{137}Cs deposition are estimated to be equal.^{5,8,59} Since over 80% of the activity injected into the lower and upper polar stratospheric compartments can be expected to deposit in the hemisphere of injection,²⁹ the average cumulative deposition of ^{137}Cs in the Northern Hemisphere following the hypothetical injection of 2000 Mt of fission products into this region of the stratosphere would be about $1.2 \mu\text{Ci}/\text{m}^2$. The average deposition in the 30 to 50°N latitude band would be about twice as great,²⁹ or $2.4 \mu\text{Ci}/\text{m}^2$. A dose-conversion factor of $0.04 (\text{rad}/\text{year})/(\mu\text{Ci}/\text{m}^2)$ coupled with a mean life of 44 years leads to an external dose commitment of 4.2 rads from ^{137}Cs (Ref. 59). The actual dose to the gonads and bone marrow would be about one-fifth as great, or about 0.85 rad, because of shielding by building structures and screening by the human body.^{5,9}

The internal dose commitment to these tissues from stratospheric ^{137}Cs , assuming milk consumption at the rate of 1 liter/day, is estimated according to our present scheme as the product of the dose rate, 0.29 rad/year (Table 20), and the mean life of ^{137}Cs in the stratosphere. The half-residence time of debris is estimated to be 5 months in the lower polar stratosphere and about 2 years in the upper polar stratosphere.²⁹ If we assume a half-residence time of 1 year, the dose commitment from ^{137}Cs via milk would be 0.42 rad. This seems to be a reasonable value in relation to the total estimated external or internal dose commitment of 0.84 rad since milk is known to contribute a substantial fraction of the dietary ^{137}Cs and since direct contamination is regarded as the predominant pathway for the entry of ^{137}Cs into foods.^{6,0} Bear in mind that this analysis is confined to the contamination of food as a result of direct contamination of vegetation. For ^{90}Sr , uptake from soil over the long term can be expected to make a major contribution to the contamination of terrestrial foods.^{6,0}

Although the external and internal dosages from ^{137}Cs deposition would be comparable, it is important to note that initially the internal dose rate will exceed the external dose rate. The cumulative ground deposition of ^{137}Cs from stratospheric deposition would be about $1.0 \mu\text{Ci}/\text{m}^2$ at the end of the year following the hypothetical attack. The gamma field associated with such a deposition of ^{137}Cs is $0.04 \text{ rad}/\text{year}$, which is considerably less than the estimated initial average dose rate via milk ($0.29 \text{ rad}/\text{year}$) shown in Table 20. If we consider the other dietary sources of ^{137}Cs and at the same time make more reasonable assumptions regarding average rates of ingestion, the internal dose rate would still initially exceed the external dose rate to the degree shown above or to an even greater degree.

Evaluation of Risk

This analysis was undertaken to estimate potential levels of food contamination and dosage to individuals and is not intended to evaluate risk from radiation exposure either to individuals or to populations. If the dosage estimates are to be

used for risk evaluation, we must take into account two factors: how the dose from a given nuclide is spatially distributed among tissues and the relative susceptibility of the cell types involved.^{6,1} The ^{90}Sr , for example, concentrates in bone. The risk of developing malignant diseases, which is associated with ^{90}Sr deposition, is a consequence of the dosages delivered to the cells that line bone surfaces and to bone marrow. The dose delivered to the cells that line bone surfaces has been estimated to be about one-half and that to bone marrow about one-fourth the mean dose delivered to bone.^{6,2} The concentration of ^{90}Sr in bone is so very much greater than that in other tissues that the estimated whole-body dose would not be representative of the dose to the gonads or to other soft tissues. Thus the gonad dose from ^{90}Sr is usually neglected. On the other hand, ^{137}Cs is distributed more or less uniformly; thus the dose to the gonads, bone marrow, and cells that line bone surfaces would be comparable to the estimated whole-body dose.^{5,9}

SUMMARY

A method was developed for predicting the internal dose that could result when radionuclides are released to the biosphere and deposited on agricultural land. By means of this analysis, we can identify the nuclides that could contribute most to the internal dose. The method was used to estimate the potential levels of food contamination and the dose commitment to man as a consequence of a nuclear attack. Neutron-activation products as well as fission products were considered as source terms. Of the many nuclides considered, relatively few were singled out as critical. It has been recognized many times that the potential dosage to a child's thyroid from isotopes of iodine via milk would be the principal internal hazard in the immediate postattack period. Thus, if normally functioning cows were grazing on pasture contaminated by unfractionated fission products deposited as small particles, children consuming the milk could receive thyroid dosages exceeding the open-field gamma dose by two orders of magnitude. The dosages to the whole body and bone would not exceed the external dose. Neutron-activation products of the environment would not be expected to contribute more than one-tenth of the total dose to the whole body and bone. Activation products of device origin would contribute little to the internal dose via the terrestrial pathways considered. Dosages attributable to a comparable deposition of large particles (such as are characteristic of close-in fallout) would be lower by a factor of 10 or more. As we might expect, the meat pathway would be unimportant compared with the milk pathway following single depositions on vegetation.

Preliminary estimates were made for the average dose rates that could result from the initial rate of deposition of the nuclides injected into the stratosphere. To no one's surprise, ^{90}Sr and ^{137}Cs would predominate among the contributors to the total dose rate. In this situation, where there is continuous

deposition extending in time, the meat pathway would be more comparable to the milk pathway in importance than was the case for single deposition. Neutron-activation products, particularly those of device origin, would not contribute substantially to the dose rates from stratospheric deposition. Comparison of the estimated dose rates from the stratospheric deposition of ^{90}Sr and ^{137}Cs with the dosages from the single deposition points out the important role of the stratosphere as a reservoir from which, sooner or later, essentially all ^{90}Sr and ^{137}Cs is transported to ground level, where it can deposit on vegetation and soil and contribute to the internal dose commitment before radioactive decay. The internal dose commitment from this source would constitute a residual long-term burden, which would be a major fraction of the total burden from these nuclides.

ACKNOWLEDGMENTS

This work was performed under the auspices of the U. S. Atomic Energy Commission.

We are pleased to acknowledge helpful discussions with Daniel W. Wilson, Fallout Studies Branch, Division of Biology and Medicine, U. S. Atomic Energy Commission, and with the following investigators from the Lawrence Radiation Laboratory, Livermore: Kendall R. Peterson, K Division, and Arthur R. Tamplin, Bio-Medical Division. We also wish to thank R. Scott Russell, Agricultural Research Council, Letcombe Laboratory, Wantage, Berkshire, United Kingdom, for helpful comments and suggestions. We gratefully acknowledge the assistance provided by C. Ann Burton and Stanley E. Thompson in updating the Handbook parameters and making them available, by Michael W. Pratt and Gary A. Kortan in programming and computation, by Yvonne Ricker and Thelma Smith in data handling and processing, and by Valeska Evertsbusch in editing the manuscript.

We are grateful to J. P. Witherspoon and F. G. Taylor, Jr.,^{3,3} and to J. E. Johnson and A. I. Lovaas^{34,35} for making results of their studies available to us in advance of formal publication.

REFERENCES

1. Y. C. Ng, Estimation of the Maximum Dose to Man from the Fallout of Radionuclides on Agricultural Land, in *Biological Implications of the Nuclear Age*, Lawrence Radiation Laboratory, Livermore, Calif., Mar. 5-7, 1969, Bernard Shore and Frederick Hatch (Coordinators), AEC Symposium Series, No. 16 (CONF-690303), pp. 95-124, 1969.
2. R. S. Russell, Dietary Contamination: Its Significance in an Emergency, in *Radiological Protection of the Public in a Nuclear Mass Disaster*, Proceedings of a Symposium held at Interlaken, Switzerland, May 26-June 1, 1968, Report CONF-680507, pp. 279-306. Fachverband für Strahlenschutz.

3. S. L. Brown, H. Lee, and O. S. Yu, Postattack Food Production and Food and Water Contamination, Final Report, Report SRI Project No. MU-6250-050, Stanford Research Institute, 1968.
4. Y. C. Ng, Estimation of the Internal Dose to Man from the Radionuclides Produced in a Surface Explosion of a Nuclear Device, in Radiological Protection of the Public in a Nuclear Mass Disaster, Proceedings of a Symposium held at Interlaken, Switzerland, May 26–June 1, 1968, Report CONF-680507, pp. 315–332. Fachverband für Strahlenschutz.
5. M. W. Pratt, Prediction of the Dosage to Man from the Fallout of Nuclear Devices. VII. Estimation of the Maximum Dose Rate from the Continuous Release of Radionuclides in the Biosphere, USAEC Report UCRL-50163(Pt. 7), Lawrence Radiation Laboratory, Livermore, Nov. 2, 1970.
6. Y. C. Ng, C. A. Burton, S. E. Thompson, R. K. Tandy, H. K. Kretner, and M. W. Pratt, Prediction of the Maximum Dosage to Man from the Fallout of Nuclear Devices. IV. Handbook for Estimating the Maximum Internal Dose from Radionuclides Released to the Biosphere, USAEC Report UCRL-50163(Pt. 4), Lawrence Radiation Laboratory, Livermore, May 14, 1968.
7. J. C. Pettee, Example Attacks, in Proceedings of the Symposium on Postattack Recovery from Nuclear War, Fort Monroe, Va., Nov. 6–9, 1967. Report CONF-671135, pp. 9–20, Office of Civil Defense, Office of Emergency Planning, and National Academy of Sciences–National Research Council, April 1968.
8. L. E. Weaver, P. O. Strom, and P. A. Killeen, Estimated Total Chain and Independent Fission Yields for Several Neutron-Induced Fission Processes, USAEC Report USNRDL-TR-633, Naval Radiological Defense Laboratory, Mar. 5, 1963.
9. S. Glasstone, The Effects of Nuclear Weapons, Sec. 9.32, USAEC Report ACCESS-127, Defense Atomic Support Agency, 1962.
10. K. Kimura, Radiochemical Analysis of Radioactive Dusts, in *Proceedings of the Second United Nations International Conference on the Peaceful Uses of Atomic Energy, Geneva, 1955*, Vol. 7, pp. 196–209, United Nations, New York, 1956.
11. C. F. Miller, Fallout and Radiological Countermeasures, Volume I, Report AD-410522, p. 52, Stanford Research Institute, January 1963.
12. W. H. Langham and E. C. Anderson, Entry of Radioactive Fallout into the Biosphere and Man, *Bull. Schweiz. Akad. Med. Wiss.*, **14**: 434–478 (1958).
13. H. W. Feely, H. Seitz, R. J. Lagomarsino, and P. E. Biscaye, Transport and Fallout of Stratospheric Radioactive Debris, *Tellus*, **18**: 316–328 (1966).
14. C. W. Thomas, J. A. Young, N. A. Wogman, and R. W. Perkins, The Measurement and Behavior of Airborne Radionuclides Since 1962, in *Radionuclides in the Environment*, Advances in Chemistry Series, No. 93, pp. 158–172, American Chemical Society, Washington, D. C., 1970.
15. A. W. Klement, Radioactive Fallout Phenomena and Mechanisms, *Health Phys.*, **11**: 1265–1274 (1965).
16. M. Eisenbud, *Environmental Radioactivity*, p. 307, McGraw-Hill Book Company, Inc., New York, 1963.
17. H. A. Tewes, Results of the Schooner Excavation Experiment, in Engineering with Nuclear Explosives, Las Vegas, Nev., Jan. 14–16, 1970, USAEC Report CONF-700101 (Vol. 1), pp. 306–333, American Nuclear Society, May 1970.
18. L. Machta, Status of Global Radioactive-Fallout Predictions, in *Radioactive Fallout from Nuclear Weapons Tests*, Germantown, Md., Nov. 3–6, 1964, A. W. Klement, Jr. (Ed.), AEC Symposium Series, No. 5 (CONF-765), pp. 369–391, 1965.
19. R. M. Lessler and F. W. Guy, Neutron-Induced Activity in Earth and Seawater from Buried and Surface Neutron Sources, USAEC Report UCRL-12407, Lawrence Radiation Laboratory, Livermore, Apr. 9, 1965.

20. Y. C. Ng, Neutron Activation of the Terrestrial Environment as a Result of Underground Nuclear Explosions, USAEC Report UCRL-14249, Lawrence Radiation Laboratory, Livermore, June 22, 1965.
21. O. I. Leipunsky, Radiation Hazards from Clean Hydrogen Bomb and Fission Atomic Bomb Explosions, *At. Energ. (U.S.S.R.)*, 3: 530 (1957); English translation in U. S. Congressional Hearings on Fallout from Nuclear Weapons Tests, pp. 2423-2447, May 5-8, 1969.
22. W. F. Libby, Radioactive Fallout, *Proc. Nat. Acad. Sci. U. S. A.*, 44: 800-820 (1958).
23. R. M. Lessler, Reduction of Radioactivity Produced by Nuclear Explosives, in Engineering with Nuclear Explosives, Las Vegas, Nev., Jan. 14-16, 1970, USAEC Report CONF-700101(Vol. 2), pp. 1563-1568, American Nuclear Society, May 1970.
24. J. R. Martin and J. J. Koranda, The Importance of Tritium in the Civil-Defense Context, this volume.
25. J. A. Miskel, Characteristics of Radioactivity Produced by Nuclear Explosives, Engineering with Nuclear Explosives, Proceedings of the Third Plowshare Symposium, Davis, Calif., Apr. 21-23, 1964, USAEC Report TID-7695, pp. 153-158, University of California and AEC San Francisco Operations Office.
26. H. A. Tewes, Radioactivity from Nuclear Excavation Explosives, USAEC Report UCRL-71323, Lawrence Radiation Laboratory, Livermore, Oct. 23, 1968.
27. G. V. LeRoy, Re-examination of NCRP Report No. 29, in Radiological Protection of the Public in a Nuclear Mass Disaster, Proceedings of a Symposium held at Interlaken, Switzerland, May 26-June 1, 1968, Report CONF-680507, pp. 494-516, Fachverband für Strahlenschutz.
28. A. R. Tamplin, Prediction of the Maximum Dosage to Man from the Fallout of Nuclear Devices. I. Estimation of the Maximum Contamination of Agricultural Land, USAEC Report UCRL-50163(Pt. 1), Lawrence Radiation Laboratory, Livermore, Jan. 3, 1967.
29. K. R. Peterson, An Empirical Model for Estimating World-Wide Deposition from Atmospheric Nuclear Detonations, *Health Phys.*, 18: 357-378 (1970).
30. T. V. Crawford, A Computer Program for Calculating the Atmospheric Dispersion of Large Clouds, USAEC Report UCRL-50179, Lawrence Radiation Laboratory, Livermore, Nov. 23, 1966.
31. A. C. Chamberlain, Interception and Retention of Radioactive Aerosols by Vegetation, *Atmos. Environ.*, 4: 57-78 (1970).
32. S. E. Thompson, Effective Half-Life of Fallout Radionuclides on Plants with Special Emphasis on Iodine-131, USAEC Report UCRL-12388, Lawrence Radiation Laboratory, Livermore, Jan. 29, 1965.
33. J. P. Witherspoon and F. G. Taylor, Jr., Interception and Retention of a Simulated Fallout by Agricultural Plants, *Health Phys.*, 19: 493-499 (1970).
34. J. E. Johnson and A. I. Lovaas, Retention of Near-In Fallout by Field Crops and Livestock, Report AD-715423, Colorado State University, 1970.
35. A. I. Lovaas and J. E. Johnson, Retention of Near-In Fallout by Crops, this volume.
36. C. F. Miller, The Retention by Foliage of Silicate Particles Ejected from the Volcano Irazu in Costa Rica, in *Radioecological Concentration Processes*, Proceedings of an International Symposium, Stockholm, Apr. 25-29, 1966, pp. 501-525, Pergamon Press, Inc., London, 1967.
37. J. J. Koranda, Agricultural Factors Affecting the Daily Intake of Fresh Fallout by Dairy Cows, USAEC Report UCRL-12479, Lawrence Radiation Laboratory, Livermore, Mar. 19, 1965.
38. G. D. Potter, D. R. McIntyre, and D. Pomeroy, Transport of Fallout Radionuclides in the Grass-to-Milk Food Chain Studied with a Germanium Lithium-Drifted Detector, *Health Phys.*, 16: 297-300 (1969).

39. G. D. Potter, G. M. Vattuone, and D. R. McIntyre, Fate of Fallout Ingested by Dairy Cows, this volume.
40. G. D. Potter, Lawrence Radiation Laboratory, Livermore, personal communication, 1970.
41. R. J. Chertok and S. Lake, Fate of Fallout Ingested by Swine and Beagles, this volume.
42. W. C. Hanson, D. G. Watson, and R. W. Perkins, Concentration and Retention of Fallout Radionuclides in Alaskan Arctic Ecosystems, *Radioecological Concentration Processes*, Proceedings of an International Symposium, Stockholm, Apr. 25–29, 1966, pp. 233–245, Pergamon Press, Inc., London, 1967.
43. C. E. Jenkins and W. C. Hanson, Radionuclide Distribution in the Alaskan Arctic Ecosystem, in Pacific Northwest Laboratory Annual Report for 1968 to the USAEC Division of Biology and Medicine. Volume II. Physical Sciences. Part II. Radiological Sciences, USAEC Report BNWL-1051(Pt. 2), pp. 14–17, Battelle–Northwest, June 1969.
44. C. F. Miller and P. D. LaRiviere, Introduction to Long-Term Biological Effects of Nuclear War, Report SRI Project No. MU-5779, Stanford Research Institute, 1966.
45. M. T. Kleinman and H. L. Volchok, Radionuclide Concentrations in Surface Air: Direct Relationship to Global Fallout, *Science*, 166: 376–377 (1969).
46. K. R. Peterson, Lawrence Radiation Laboratory, Livermore, personal communication, 1970.
47. D. W. Wilson, G. M. Ward, and J. E. Johnson, A Quantitative Model of the Transport of ^{137}Cs from Fall-out to Milk, in *Environmental Contamination by Radioactive Materials*, Symposium Proceedings, Vienna, Mar. 24–28, 1969, pp. 125–134, International Atomic Energy Agency, Vienna, 1969 (STI/PUB/226).
48. Fallout Program Quarterly Summary Reports, U. S. Atomic Energy Commission Health and Safety Laboratory, New York Operations Office.
49. *Radiological Health Data and Reports*, published monthly by the U. S. Public Health Service.
50. Great Britain Agricultural Research Council, Strontium-90 in Human Diet in the United Kingdom, 1958. Report No. 1, British Report ARCRL-1, 1959.
51. Agricultural Research Council, Annual Report, 1963–1964, British Report ARCRL-12, 1964.
52. Agricultural Research Council, Annual Report, 1964–1965. British Report ARCRL-14, 1965.
53. A. Aarkrog, J. Lippert, and J. Petersen, Environmental Radioactivity in Denmark in 1962, Danish Report No. 63, 1963.
54. A. Aarkrog and J. Lippert, Environmental Radioactivity in Denmark in 1963, Danish Report No. 85, 1964.
55. A. Aarkrog and J. Lippert, Environmental Radioactivity in Denmark in 1964, Danish Report No. 107, 1965.
56. Report of the United Nations Scientific Committee on the Effects of Atomic Radiation, General Assembly Official Records, Twenty-first Session, Supplement No. 14 (A/6314), United Nations, New York, 1966.
57. B. Underdal, Measurement of Cs^{137} in Meat from Different Species, 1965–1967, *Nord. Veterinarmed.*, 20: 344–353 (1968).
58. Estimates and Evaluation of Fallout in the United States from Nuclear Weapons Testing Conducted Through 1962, Report No. 4, Federal Radiation Council, 1963.
59. Report of the United Nations Scientific Committee on the Effects of Atomic Radiation, General Assembly Official Records, Twenty-fourth Session, Supplement No. 13 (A/7613), United Nations, New York, 1969.
60. R. S. Bruce and R. S. Russell, Agricultural Aspects of Acute and Chronic Contamination Situations, in *Environmental Contamination by Radioactive Materials*, Symposium

- Proceedings, Vienna, Mar. 24–28, 1969, pp. 79–89, International Atomic Energy Agency, Vienna, 1969 (STI/PUB/226).
61. International Commission on Radiological Protection, *Radiosensitivity and Spatial Distribution of Dose*, ICRP Publication 14, Pergamon Press, Inc., New York, 1969.
 62. Report of the United Nations Scientific Committee on the Effects of Atomic Radiation, General Assembly Official Records, Seventeenth Session, Supplement No. 16 (A/5216), United Nations, New York, 1962.
 63. L. L. Schwartz, Lawrence Radiation Laboratory, Livermore, personal communication, 1970.
 64. H. W. Feely and F. Bazan, Stratospheric Distribution of Nuclear Debris in 1962, 1963, and 1964, in *Radioactive Fallout from Nuclear Weapons Tests*, Germantown, Md., Nov. 3–6, 1964, A. W. Klement, Jr. (Ed.), AEC Symposium Series, No. 5 (CONF-765), pp. 301–322, 1965.
 65. G. H. Higgins, Calculation of Radiation Fields from Fallout, USAEC Report UCID-4539, Lawrence Radiation Laboratory, Jan. 25, 1963.

RETENTION OF SIMULATED FALLOUT BY SHEEP AND CATTLE

JAMES E. JOHNSON and ARVIN I. LOVAAS

Department of Animal Science, Colorado State University, Fort Collins, Colorado

ABSTRACT

The initial retention of 88- to 175- μ or 175- to 350- μ near-in fallout-simulant sand on the backs of cattle averaged 50%. This was independent of mass loading up to 100 g/m². The retention half-time of simulant deposited on the animals' backs averaged 9 days for cattle kept under feedlot conditions and 2 days for cattle kept under pasture conditions.

The fecal excretion of simulant sand given to sheep and cattle could be described by single exponential functions. The mean lifetime ($1.44T_{1/2}$) of material in the gut averaged 1.1 days in sheep and 4.8 days in cattle.

The beta-particle radiation dose to grazing and feedlot animals from near-in fallout would be principally due to retention of particulates on the body and their passage through the gut.

RETENTION ON THE SURFACE OF ANIMALS

Near-in fallout-simulant sand was spread as an aerosol over 26 Hereford and Angus cattle by means of a blower. The sand, which was labeled with ¹⁷⁷Lu for identification by gamma-ray spectrometry, was in the particle range either 88 to 175 μ or 175 to 350 μ . The aerosol was generated at a height sufficient to guarantee terminal velocity before deposition. Initial retention was determined by comparison with deposition on disk impactors. A 0.6-cm-thick 7.5-cm-diameter NaI(Tl) scintillation crystal was used for counting.

The initial retention, as well as the retention as a function of time, was dependent on the location on the surface of the animal's back. The mean initial retention of all the sites monitored was about 50% for studies using the 88- to 175- μ sand. For the 175- to 350- μ size the mean initial retention was also near 50%.

Figure 1 shows the retention vs. time at four different locations for one cow. Loss is reasonably rapid for the convex locations and is minimal for the flat or concave locations.

Retention was also strongly dependent on the activity of the animals. Figure 2 compares retention on animals kept under feedlot conditions with that on animals allowed the greater mobility of pasture conditions. The retention half-time for pastured animals was less than 2 days but was greater than 9 days for animals kept under feedlot conditions. The loss rate for the coarse sand was slightly greater than for the fine sand.

In summary, the greatest beta-radiation skin dose would be to the region between the hook bones, and, since most U. S. cattle are kept under pasture conditions, a retention half-time of 2 days should probably be used in the dose calculation.

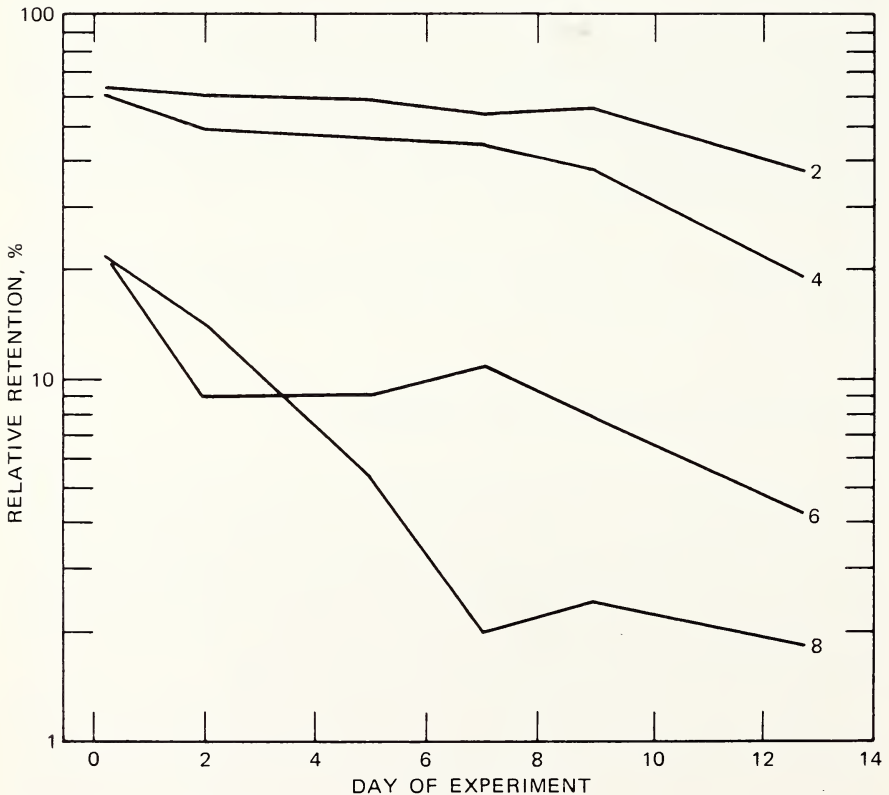

Fig. 1 Typical retention of 88- to 175- μ sand at four locations on the back of cow 712: curve 2, between tuber coxa; curve 4, between shoulders; curve 6, paralumbar fossa; and curve 8, over shoulder joint.

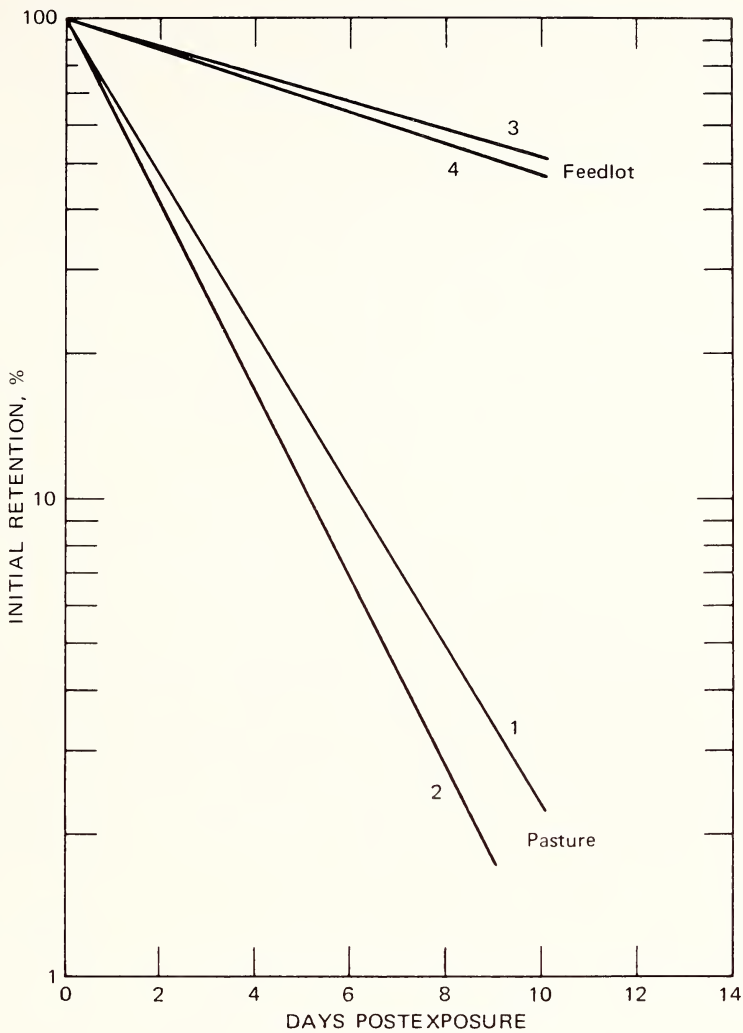

Fig. 2 Composite normalized retention on the backs of cows, comparing particle size and cattle kept under pasture conditions and under feedlot conditions. Curves 1 and 3 are for 88- to 175- μ sand; curves 2 and 4, for 175- to 350- μ sand.

RATE OF PASSAGE OF NEAR-IN FALLOUT IN THE GUT

The radiation dose to segments of the gut would be from unabsorbed near-in fallout reaching the gut by either ingestion or inhalation. The radiation dose to the whole gut or to any segment is proportional to the average time that

particles spend in any location. The definition of the mean retention time or mean transit time is the summation of times that individual particles spend in the gastrointestinal tract divided by the total number of particles. By this definition, however, mean retention time is very difficult to determine.

If the ruminant gut is considered in a one-compartment model where mixing of digesta is very rapid and emptying is by first-order kinetics, the mean retention time can be calculated very simply. It is the reciprocal of the first-order rate constant, or 1.44 times the biological half-time. A typical excretion curve of 88- to 175- μ sand particles in sheep is given in Fig. 3.

The true estimate of the mean retention time (τ) from such data is the weighted average abscissal value (i.e., the centroid of the curve), and, if the function of the curve is not known, mean retention time must be determined by approximation methods. From our data, however, the area under the buildup portion of the curve is small compared with the total area, and there is little error in calculating τ from the measured half-life.

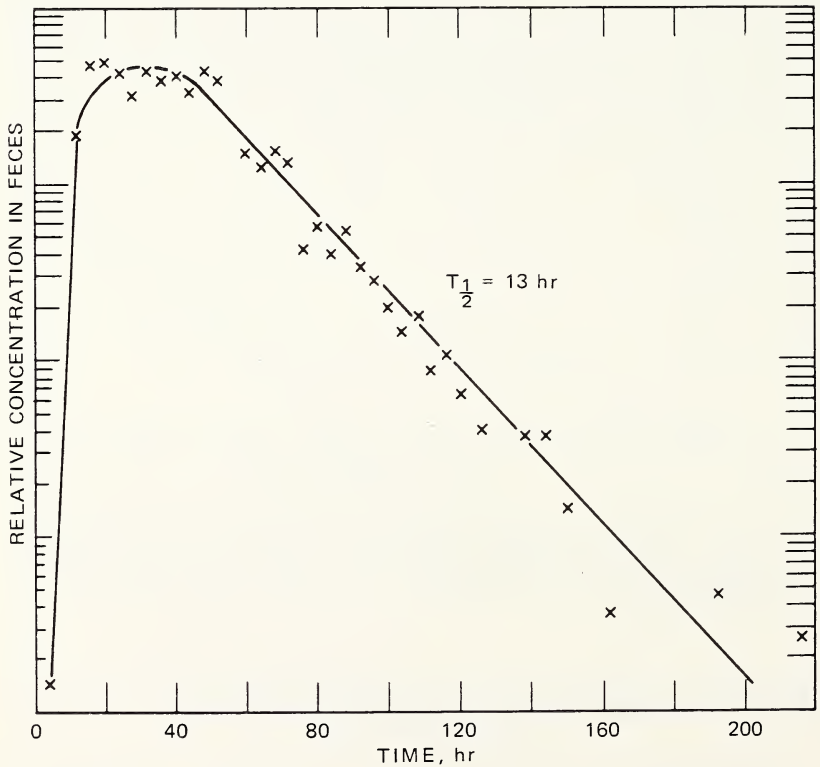

Fig. 3 Typical excretion function of a single dose of 88- to 175- μ ^{177}Lu -labeled sand in sheep.

There is actually a great amount of data in the animal-science literature on the rate of passage of digesta in ruminants since this is an important factor in determining nutritional efficiency of feedstuffs.¹ Rate of passage as calculated from our model is simply the average mass of rumen digesta at any time divided by τ .

The values observed from our study are shown in Table 1. They are, in general, greater than those reported in the literature for feedstuffs of the same particle size. The data in Table 1 show little difference caused by sand particle size but an appreciable difference between sheep and cattle.

Table 1

MEAN LIFETIMES OF SIMULATED NEAR-IN FALLOUT
IN THE GUT OF SHEEP AND CATTLE

Sand size, μ	Lifetime in sheep, days	Lifetime in cattle, days
88 to 175	1.2	4.8
175 to 350	1.1	

A very important finding was that for both sizes of sand and with both sheep and cattle there was 98 to 100% recovery. This implies that very little, if any, of the sand particles are trapped in fine structures of the GI tract.

Again we must stress that our data correspond to normal intake conditions. If dose to the GI tract is sufficient to cause appreciable damage, then decreases in motility are to be expected; this would increase retention times and further increase the dose.

REFERENCE

1. C. C. Balch and R. C. Campling, Rate of Passage of Digesta Through the Ruminant Digestive Tract, in *Physiology of Digestion in the Ruminant*, pp. 108-123, Second International Symposium, Ames, Iowa, 1964, R. W. Dougherty et al. (Eds.), Butterworth & Co. (Publishers) Ltd., London, 1965.

SIMULATED-FALLOUT-RADIATION EFFECTS ON SHEEP

L. B. SASSER, M. C. BELL, and J. L. WEST
UT-AEC Agricultural Research Laboratory, Oak Ridge, Tenn.

ABSTRACT

Sixty-four yearling lambs were exposed to the following radiation treatments: (1) ^{90}Y beta irradiation of the gastrointestinal tract (2.4 mCi/kg of body weight for 3 consecutive days, (2) ^{90}Y beta irradiation of the skin (57,000 rads), (3) ^{60}Co irradiation of the total body (240 R), or (4) all possible combinations of these treatments. Irradiation of the gastrointestinal tract produced severe injury to the rumen and abomasum and resulted in severe anorexia and diarrhea and a significant loss (>20%) of body weight. Nearly 50% of the lambs subjected to combined gastrointestinal and whole-body irradiation died within 60 days, but lambs in other treatment groups were able to recover from the initial irradiation insult. Skin irradiation caused no immediate threat to life but affected survival several months postirradiation. Implications of multiple irradiation trauma on animal survival are discussed from a postattack recovery viewpoint.

In the event of a surface thermonuclear detonation, farm livestock located downwind from the site of attack would be vulnerable to fallout radiation. The response of grazing livestock to fallout radiation would result from the combined insults of external whole-body gamma irradiation, irradiation from contaminated feed, and beta irradiation to animals' skin. Considerable information is available on the effects of whole-body gamma radiation on large animals,^{1,2} and incidences of skin irradiation from radioactive fallout have been reported in livestock^{3,4} as well as in man.⁵ Less is known about the response of the gastrointestinal tract of large animals to ingested radioactive materials. Nold, Hayes, and Comar,⁶ measuring internal radiation doses in dogs and goats using implanted glass-rod dosimeters, reported that, when a soluble ^{90}Y solution was given, the greatest doses were measured in the lower large intestine. Lethal levels of ingested soluble ^{144}Ce - ^{144}Pr severely damaged the rumen and omasum of sheep.⁷ More recently it has been shown that ingestion by sheep of insoluble ^{90}Y -labeled fallout simulant at levels to be expected in fallout contamination

severely affected animal health and productivity but was seldom lethal.⁸ Furthermore, the sites of major damage were confined to the rumen and abomasum.

Even though previous studies demonstrate the effects of radiation on livestock, few studies have been conducted to determine the interaction of simultaneous administration of multiple modes of irradiation. Baxter et al.⁹ reported that the additional trauma of thermal burns increased mortality in whole-body X-irradiated (400 R) swine. George, Hackett, and Bustad¹⁰ irradiated lambs by three different methods (whole-body X-ray, oral ^{131}I , and beta irradiation of the skin) to study the additive effects at two planes of nutrition. None of the single or combined treatments were lethal, and weight gain appeared to have been influenced mainly by the nutritional treatments. The need for information on the survival of large animals in a postattack fallout situation was recently emphasized,¹¹ and this study was initiated to investigate these interactions.

EXPERIMENTAL PROCEDURES

Yearling wether lambs of mixed breeding were treated for parasites, shorn, and gradually adjusted to a 680-g ration of pelleted alfalfa preconditioned with 140 g of water. The ration, which was supplemented with trace-mineralized salt, represented about 80% of ad libitum consumption. The sheep, averaging 31.1 ± 0.6 kg in weight, were placed in collection stalls approximately 7 days before irradiation. One wether was randomly assigned to each of eight treatment groups: (1) control, (2) gastrointestinal irradiation (GI), (3) whole-body gamma irradiation (WB), (4) skin irradiation (Skin), (5) WB + Skin, (6) GI + Skin, (7) GI + WB, and (8) GI + WB + Skin. Eight replicates of each treatment were made over a period of 9 months.

A sublethal bilateral exposure of 240 R (midline dose of 145 rads) at 1 R/min from ^{60}Co sources¹² was used for whole-body gamma irradiation. Sheep assigned to the four treatments requiring gamma irradiation were simultaneously irradiated 12 to 16 hr before gastrointestinal and skin irradiation began. Four 43-by-28-cm, flexible, sealed ^{90}Sr - ^{90}Y plaques¹³ with surface dose rates ranging from 913 to 1570 rads/hr were used to irradiate about 12% of the body area. A plaque was affixed to the thoracolumbar region of the back of each sheep and left until a total beta dose of 57,000 rads had been delivered. The ratio of skin beta dose to whole-body gamma dose in the combined treatments was 240 to 1—the ratio estimated for the cattle exposed during the Trinity shot³ in 1945.

The insoluble labeled fallout simulant (^{90}Y -labeled silica sand 88 to 175 μ in size) was mixed with the daily ration and fed for 3 consecutive days, as previously described.⁸ An initial activity of 2.4 mCi/kg of body weight was fed on day 1, but, because of ^{90}Y decay, only 1.8 and 1.4 mCi/kg remained when

the ration was fed on days 2 and 3, respectively. The specific activity of the various batches of sand ranged from about 5 to 10 mCi/g; thus 6 to 17 g of sand were fed daily.

The half-life, energy, and particle size of the synthetic fallout were selected to simulate fallout from a 1-Mt or greater surface nuclear burst at a distance sufficient for most livestock to survive the gamma dose. The gastrointestinal dosimetry procedure and results are described in detail by Wade et al.¹⁴

Consumption of feed and water and excretion of feces and urine were recorded daily. Six to seven weeks after treatment, the animals were removed from the collection stalls and fed an alfalfa-grass hay and grain ration ad libitum. Body weights were recorded periodically throughout the study.

Fecal samples were oven dried at 60°C, and bremsstrahlung was counted with a well-type gamma scintillation counter set to exclude all pulses less than 2 MeV. This technique required a shorter decay period before counting than did beta counting and eliminated the detection of any ⁹⁰Sr contaminate. Standards were prepared by adding known quantities of ⁹⁰Y-labeled sand to non-radioactive fecal material.

Necropsies were performed on all sheep at death and on surviving sheep slaughtered 40 to 64 weeks postirradiation. Selected tissues were preserved in 10% buffered formalin for microscopic examination (detailed histopathology is reported elsewhere¹⁵).

RESULTS

Clinical Observations

Clinical signs of digestive disturbances were manifest in all sheep ingesting the synthetic fallout. Anorexia appeared between the fourth and tenth day after irradiation and continued in many of the sheep for several weeks (Fig. 1). There were no significant differences in severity of anorexia among the various GI-treatment groups; however, the duration of anorexia was less in sheep subjected to both GI and Skin irradiation. A significant interaction ($P < 0.05$) was observed among trials for feed intake, but this difference could not be correlated with the specific activity or the amount of sand fed. Feed intakes of all non-GI treatments did not differ from those of the control animals.

From minor to severe diarrhea was observed in the sheep after ingestion of ⁹⁰Y-contaminated feed. Fecal water began to increase 3 to 4 days after initiation of ⁹⁰Y feeding, reached a maximum at the fifth or sixth day, and then declined, probably as a result of the anorexia (Fig. 2). Another increase in fecal water, occurring between days 11 and 17, was not synchronous among all GI-treatment groups. The severe diarrhea was frequently accompanied by a slight mucous discharge and occasionally by a discharge of bright red blood, but hemorrhagic diarrhea was not evident. Marked changes in fecal water were not

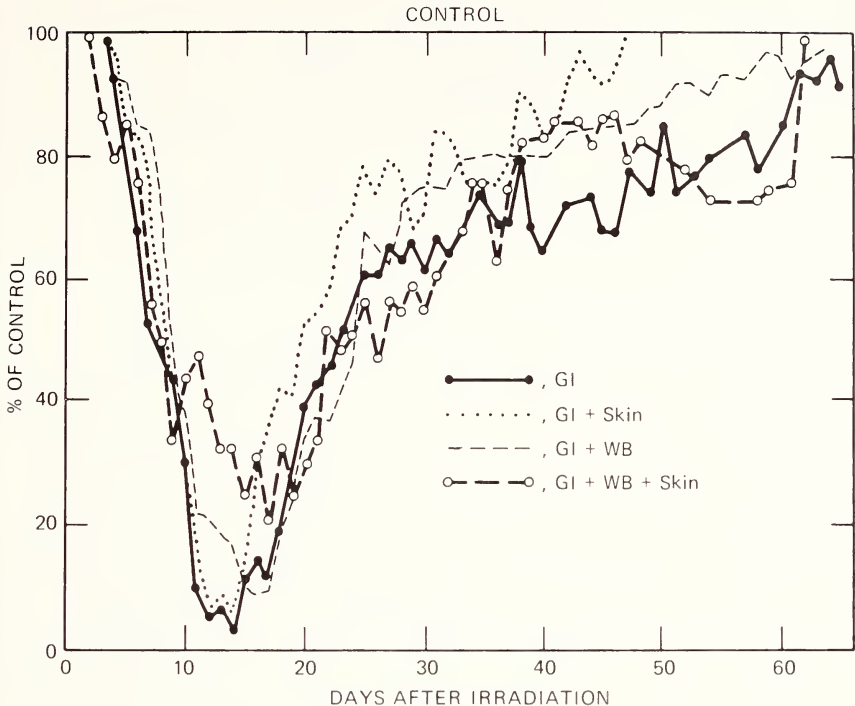

Fig. 1 Effect of gastrointestinal irradiation on feed consumption by sheep as a percent of feed consumption by control sheep. Feed intake of sheep receiving whole-body (WB) gamma and skin irradiation did not differ from that of control sheep.

observed in sheep of the non-GI-treatment groups during the 3-week period, nor was diarrhea a frequent occurrence among the surviving sheep after 3 to 4 weeks.

A marked increase in both water consumption and urine excretion ($P < 0.05$) was also associated with the severe illness of the GI-treatment groups (Table 1). The WB-treatment group also showed a less pronounced drop in water intake and urine excreta. However, no significant change in percentage of body water per kilogram of body weight as measured by tritium dilution was observed in a study using many of these animals (unpublished data).

An increase in body temperature was frequently observed in sheep of the GI-treatment groups, but this condition was neither continuous nor consistent. Pyrexia, however, usually was observed prior to death.

The changes in body weight during the 10-week period after irradiation are shown in Fig. 3. By the second week all the GI-treatment groups had lost approximately 20% of their initial body weight; this was probably a reflection of the severe anorexia and diarrhea. The animals receiving the triple insult continued losing weight; in this they differed significantly ($P < 0.05$) from the

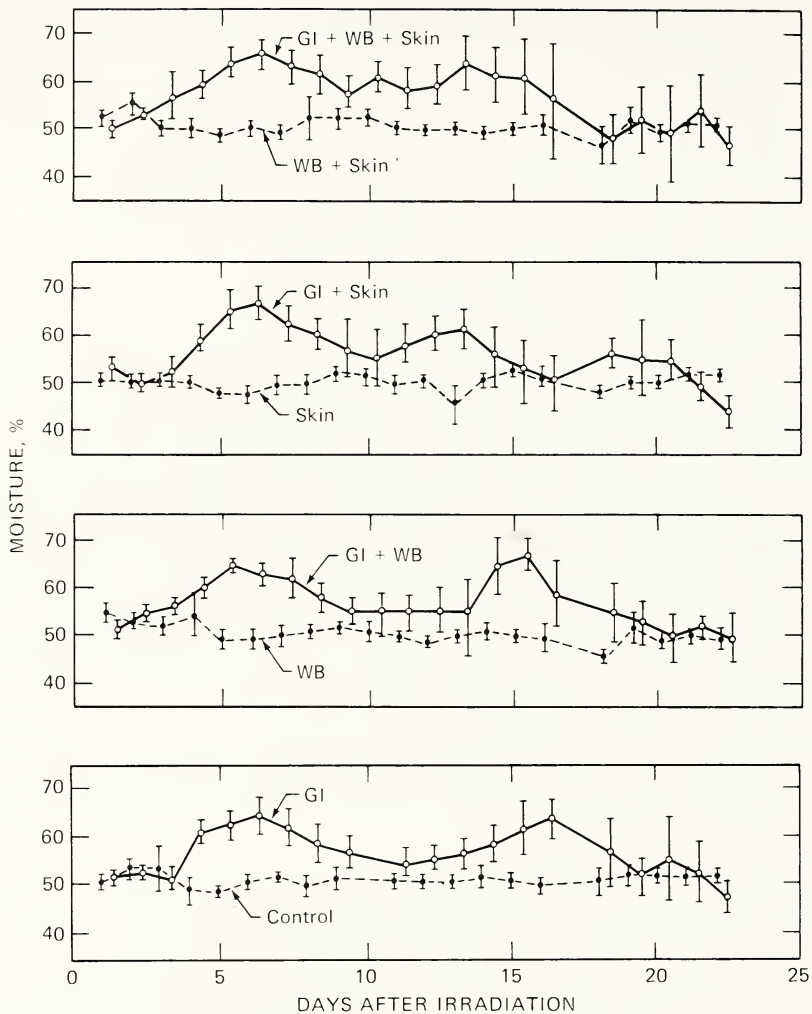

Fig. 2 Effect of irradiation on the moisture content of fecal excreta. Diarrhea occurred only in GI-irradiated sheep.

other GI-treatment groups by the fifth week. A sharp increase in body weight of the GI, GI + Skin, and GI + WB groups occurring between days 24 and 35, synchronous with the partial recovery in appetite, was probably a reflection of rumen fill.

Skin and Skin + WB irradiated sheep were unable to maintain their body weight on the restricted ration and lost over 10% of their weight by the seventh week. The WB-irradiated and control animals nearly maintained initial weight during this period of feed restriction. During the recovery period of ad libitum

Table 1
EFFECTS OF VARIOUS RADIATION TREATMENTS ON DAILY WATER CONSUMPTION AND URINE EXCRETION BY SHEEP

Treatment	Days after treatment				Days after treatment			
	1 to 6	7 to 12	13 to 18	19 to 24	1 to 6	7 to 12	13 to 18	19 to 24
	Water, ml/day*				Urine, ml/day*			
Control	929 ± 163	1206 ± 139	1180 ± 173	1257 ± 153	689 ± 78	723 ± 38	776 ± 44	804 ± 54
WB	752 ± 142	943 ± 167	754 ± 136	870 ± 137	617 ± 60	441 ± 38	341 ± 36	385 ± 42
Skin	680 ± 131	1003 ± 156	932 ± 147	1021 ± 52	592 ± 37	566 ± 40	625 ± 34	695 ± 38
GI	871 ± 149	283 ± 82	252 ± 625	596 ± 108	515 ± 40	371 ± 34	346 ± 23	361 ± 41
WB + Skin	877 ± 125	1315 ± 139	997 ± 117	1286 ± 134	563 ± 23	641 ± 17	667 ± 20	636 ± 21
GI + Skin	838 ± 154	732 ± 72	619 ± 180	869 ± 139	608 ± 30	379 ± 23	371 ± 26	417 ± 29
GI + WB	885 ± 148	930 ± 94	308 ± 86	866 ± 66	676 ± 59	863 ± 64	776 ± 56	876 ± 68
GI + WB + Skin	672 ± 128	550 ± 105	261 ± 67	520 ± 84	496 ± 52	341 ± 19	418 ± 28	422 ± 27

*Mean values ± standard error.

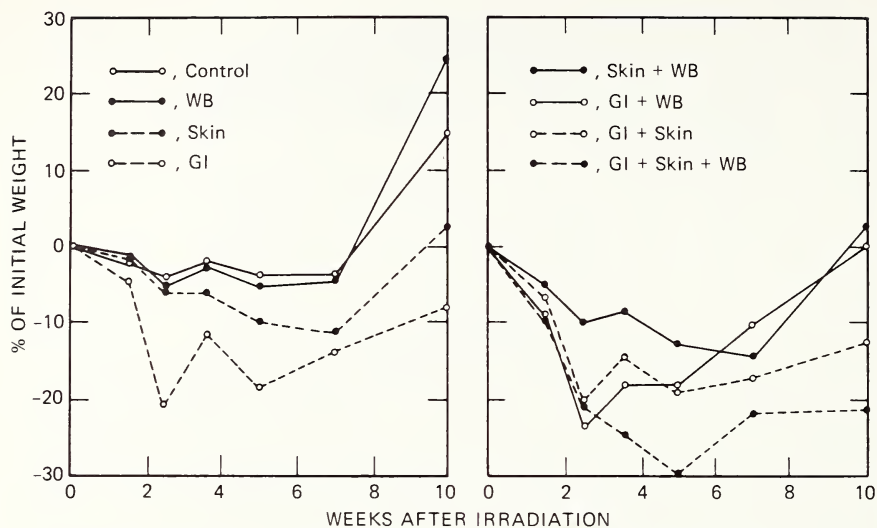

Fig. 3 Effects of irradiation on body weight (expressed as a percentage of the initial weight) of sheep fed a restricted diet for 7 weeks and then fed ad libitum.

feeding, all surviving animals gained weight. Survival weight at 40 weeks (Table 2) was significantly ($P < 0.05$) lower than that of control sheep for all treatments except WB, and the weight gain of GI + Skin and GI + Skin + WB groups was significantly less ($P < 0.05$) than that of all other treatment groups.

Table 2
EFFECT OF GI, WB, AND SKIN IRRADIATION ON SURVIVAL OF SHEEP

Treatment	Initial weight, kg	Survival* weight, kg	Deaths	
			No.	Days postirradiation
Control	31.3	55.6 ^{a†}		
WB (240 R gamma)	31.1	56.5 ^a	1	61‡
Skin (57,000 rads beta)	31.1	47.5 ^b	3	55, ‡ 114, 120
GI (2.4 mCi ⁹⁰ Y/kg)	32.6	50.5 ^b	3	25, 102, § 133 §
WB + Skin	33.1	48.8 ^b	2	156, 239
GI + Skin	31.4	36.3 ^c	2	134, § 172 §
GI + WB	30.2	52.7 ^b	4	5, 17, 19, 68 §
GI + WB + Skin	30.5	37.8 ^c	4	20, 30, 47, 61

*Forty weeks postirradiation.

†The values followed by the same letter (a, b, or c) are not different at the 5% level of significance.

‡Accidental death not attributable to radiation.

§ Killed following the development of ruminal and/or abomasal fistulae.

^{90}Y Excretion and Dosimetry

Fecal ^{90}Y excretion levels (as a percentage of the total dose) increased rapidly and reached a peak by the third or fourth day (Fig. 4). After feeding of the fallout simulant was discontinued, fecal radioactivity declined with an effective half-time of less than 1 day. Ninety-nine percent of the ^{90}Y had decayed or had been excreted by 8 to 10 days after feeding. There were no significant differences in excretion among the various GI-treatment groups.

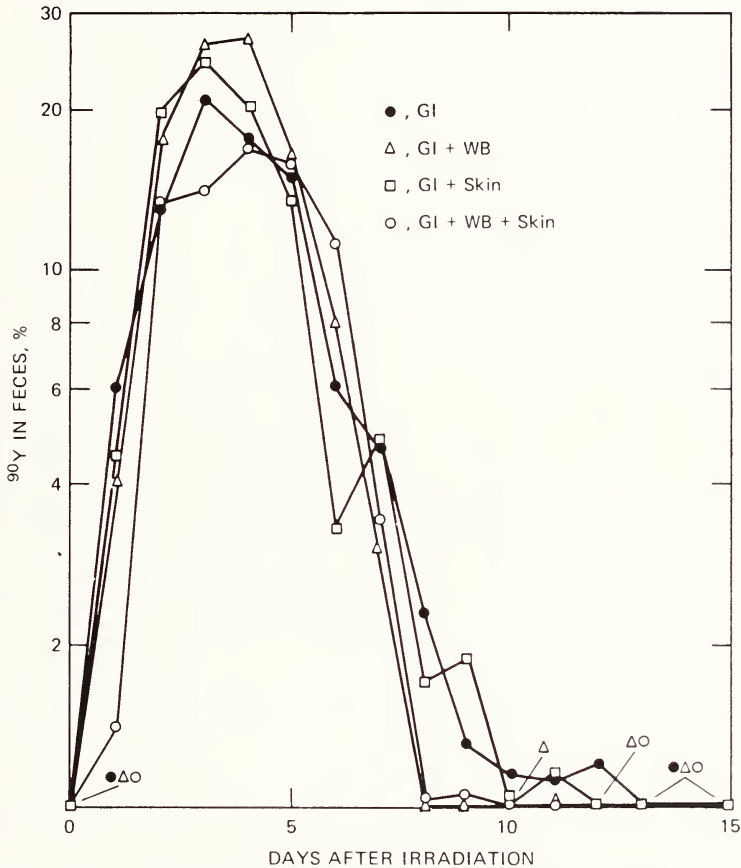

Fig. 4 Fecal excretion of ^{90}Y -labeled sand (percentage of total dose) fed for three consecutive days.

Radiophotoluminescent glass-rod dosimeters were used to estimate the absorbed dose from the ingested fallout simulant in 13 wethers of a similar weight and age.¹⁴ The total dose, measured 7 to 10 days after initiation of feeding, was greatest in the fundic region of the abomasum (4.8 to 35 krads), a site of severe radiation damage. However, the doses measured in the affected

areas of the rumen were only 0.5 to 5.3 krads and were not different from doses measured in the undamaged pyloric region of the abomasum (1.0 to 10.2 krads). This was probably due to the inability of the relatively large dosimeters to measure the dose delivered by the sand particles lodged among the papillae, rather than to a tissue-sensitivity effect.

Lethality and Gross Pathology

The number of deaths occurring in each treatment group and the number of days between irradiation and death are presented in Table 2. Early deaths occurred only in the GI-treatment groups, except for an accidental death of a Skin-irradiated sheep. Nearly 50% of the sheep receiving the two treatments involving a combination of GI and WB irradiation died within 60 days, a death rate significantly greater ($P < 0.01$) than the mortality from any of the other treatments.

Of the 24 sheep receiving Skin irradiation either as the only insult or in combination with GI or WB irradiation, six died between weeks 16 and 39. Four additional sheep were in poor condition at 40 weeks, but the remainder of the surviving Skin-irradiated sheep appeared to be healthy.

Abomasal prolapse through a hernial ring occurred in five sheep of the GI-treatment groups 68 to 172 days after treatment (Fig. 5a). In one sheep a small rumen fistula developed about 1 cm cranial to the prepuce 134 days after treatment, and a fistulous tract was seen in a sheep that died 60 days after irradiation. All these sheep were euthanatized due to their terminal condition.

The radiation damage to the gastrointestinal tract of the GI-treatment groups was similar to damage previously reported from ^{90}Y irradiation alone.⁸ Major gastrointestinal lesions of sheep dying during the early period were usually confined to the ventral and lateral regions of the rumen and to the fundic-pyloric junction and associated laminae of the abomasum. The ventral and lateral regions of the rumen usually contained three to four areas of yellow polyplike fibrino-necrosis, which became friable and detached with time, leaving a smooth, pale, underlying base. By 40 to 60 days, tan or dark-colored scar tissue with a central erosion or necrosis was usually present. The abomasum was characteristically inflamed and edematous, with a large area of hemorrhagic necrosis at the caudal fundus and cephalic pylorus. The laminae were generally inflamed and edematous, and the pylorus was occasionally hyperemic and edematous. Only a slight increase in hemorrhage could be attributed to the added insult of WB irradiation. In several cases there were fibrino-hemorrhagic serosal adhesions of the abomasum and rumen to each other and/or to the abdominal wall. A purulent exudate was usually associated with the adhesions.

Damage to the intestines was limited to mild hyperemia and edema of the duodenal mucosa. Although the laminae of the omasum was congested in several sheep, necrosis of this organ was seen in only one sheep. Hydropericardium, dilated cardiac ventricles, and heavy and edematous lungs were observed in

these sheep at necropsy. Sheep of the GI-treatment groups surviving 40 to 52 weeks had residual ruminal and/or abomasal scars when slaughtered, and in many cases the scars contained eroded or necrotic centers as shown in Fig. 5b.

The locations of major damage in the gastrointestinal tract in these sheep differ from results predicted from dosimetric studies⁶ in dogs and goats following an ingested dose of soluble ^{90}Y and studies⁷ in sheep receiving lethal levels of soluble ^{144}Ce – ^{144}Pr . The passage of sand particles through the rumen and abomasum appears to be independent of that of feed or fluids; thus sedimentation and concentration of these particles in the ventral portion of these organs resulted in significantly greater doses than expected from soluble material. In the intestinal tract the passage of sand in a homogeneous mixture with the less-fluid ingesta prevented settling of the particles and thus reduced the dose to the mucosa of the intestine.

Beta irradiation of the skin produced erythema, cessation of wool growth, moist reaction of plasma exudate, and a gradual formation of a firm crusted mat of the wool during the first 4 to 6 weeks. The wool was easily removed if mechanically disturbed, but in most cases epilation was not complete until 10 to 16 weeks after irradiation (Fig. 6a). Along with epilation was sloughing of the epidermal layer leaving exposed a hemorrhagic necrotic dermal tissue. The healing and repair process was characterized by epithelialization of the periphery (2 to 4 cm) of the wound with the sequential development of an ivory horny or leaflike material. The central area of the injury of most sheep was still covered with necrotic tissue or a granulating surface when the sheep were slaughtered (Fig. 6b). The size of the irradiated area had decreased from 43 by 28 cm to approximately 25 by 16 cm. On one sheep retained for extended observation, 6-by 3-cm horny keratinizations about 3 cm thick developed by 62 weeks.

Hydropericardium, dilated cardiac ventricles, and heavy edematous lungs were observed in Skin-irradiated sheep at death. However, milder manifestations of these abnormalities were common among Skin-irradiated sheep killed 40 to 64 weeks after irradiation.

The exact mode of death and the relation between the respiratory and cardiac involvement and the irradiation treatment of these sheep are not clear.

DISCUSSION

These results demonstrate that the additional stress of gastrointestinal irradiation injury from contaminated feed may cause not only a great loss of animal production but also a greater death rate than anticipated from WB irradiation alone. The early deaths were practically all due to WB and GI insults. The whole-body gamma LD_{50} of sheep at the dose rate used in the present study was approximately 200 rads (midline tissue dose).¹ However, when GI irradiation damage was imposed, the LD_{50} was reduced to 145 rads. With due regard for the limited sample size of this study, this is approximately a 25 to



Fig. 5a Mucosal surface of the abomasum of a sheep showing the fistula through which the lamina of the abomasum had prolapsed 14 weeks after the animal received ^{90}Y -labeled sand. Note the congested and hemorrhagic condition of the prolapsed tissue.



Fig. 5b Residual scar tissue in the rumen of a sheep 14 weeks after it received ^{90}Y -labeled sand. Similar scar tissue existed in all these animals slaughtered at 40 to 64 weeks. Note the necrotic center of the scar tissue.



Fig. 6a The irradiated area (43 by 28 cm) of a sheep's back 12 weeks after irradiation. Note the area of necrosis and the firm mat of undisturbed wool.



Fig. 6b The irradiated area (28 by 17 cm) of a sheep's back 40 weeks after irradiation. Note the ivory horny or leaflike material at the periphery, the nodular necrotic center, and the marked decrease in size of the irradiated area.

30% reduction in the LD_{50} from the whole-body gamma-ray dose. The mortality and secondary effects, such as loss of body weight, would certainly be critical to the livestock industry and would be of national importance as far as the food reserve is concerned in an emergency situation. A substantial radiation dose to the gastrointestinal tracts of livestock could result in reduction of meat production and reduced or lost milk production without causing death to the animal.

The additional stress of beta irradiation of the skin did not affect survival to a great extent for several months postirradiation. The loss in body weight was statistically significant ($P < 0.05$), but this might not have occurred if the ration had not been restricted. The large contiguous area of irradiated skin is probably an extreme situation, complete healing being virtually impossible. The fallout injury to the backs of the Alamogordo cattle was not uniform, and areas with minor or no injury probably influenced the healing of more severely affected areas.³ The fact that major injury from skin irradiation was delayed may have allowed partial recovery from WB and GI trauma before the additional stress of skin irradiation was manifest. Thus skin injury from beta burns probably would not contribute significantly to sheep mortality during the period immediately following a nuclear attack. However, this does not preclude possible effects of skin irradiation on longevity or other physiological mechanisms which can lead eventually to abnormal conditions.

Several deaths resulting from secondary effects occurred several months after irradiation. The development of hernias and fistulae would affect the sheep's longevity but not its value for food. However, accumulation in the meat of soluble fallout material such as ^{137}Cs and ^{90}Sr would be of concern. Most sheep with severely damaged skin could be used for food; few cases of liver abscesses or internal infection were apparent in these animals at death. During summer months vigilance was required in treating the injured skin to prevent severe damage from fly larvae. In winter the loss of heat from the damaged skin would be a problem and could affect the ability of these animals to grow or even to survive. The type of care necessary to prevent animal losses would be practically impossible to provide under range conditions. Nevertheless, in cases of food shortages, these survivors could still be sources of food if slaughtered prior to the onset of serious illness,¹⁶ even though the meat quality and production per animal would probably be reduced.

Consideration must be given to the probability of animal exposure at the levels used in the present study. We can assume that a sheep must graze a pasture area of 6.8 m^2 to equal the daily feed intake of the sheep in this study and that 160 mCi/m^2 of gross fission products would be present at time $H + 24 \text{ hr}$ in any area having had an exposure rate of 100 R/hr at $H + 1 \text{ hr}$.¹⁷ Thus approximately 1100 mCi of fission products could be produced by time $H + 24 \text{ hr}$ on the area grazed by one sheep during a 24-hr period. The forage would have to retain only 7% of the fallout to produce the activity fed in the present study on day 1. Recent studies of retention of fallout sand indicate values at this level, but

varying to some degree depending on the particle size, wind conditions, and pasture type and density.¹⁸ Because of decay, the fallout arrival time would influence the amount of contamination at a given area, but, with due concern for all the variables involved, the activity fed in this study is considered to be a realistic level.

From the estimated exposures of the Alamogordo cattle,³ a ratio of skin beta dose to whole-body gamma dose of 240 to 1 was used to determine the skin dose, but recent data indicate a beta-to-gamma ratio on plants of 12 to 1 from venting of underground nuclear devices.¹⁹ A beta-to-gamma ratio of 10 to 1 was not sufficient to produce the severe effects observed in cattle exposed to beta irradiation.³ This matter is probably not critical for postattack planning purposes, since even the high doses and the large areas of involvement in the present study did not affect animal survival for several months.

When predicting the vulnerability of farm livestock to fallout radiation, we must consider the effect of multiple radiation assaults on the survival and productivity of livestock. Many of our underground missile defense systems are located in areas of grazing livestock, and the possibility of surface nuclear attacks raises the question of the vulnerability of the livestock to fallout radiation.

ACKNOWLEDGMENTS

The UT-AEC Agricultural Research Laboratory is operated by the Tennessee Agricultural Experiment Station for the U. S. Atomic Energy Commission under Contract AT-40-1-GEN-242.

This work was supported by funds from the U. S. Office of Civil Defense and is published with the permission of the Dean of the University of Tennessee Agricultural Experiment Station, Knoxville.

REFERENCES

1. D. G. Brown, R. G. Cragle, and T. R. Noonan (Eds.), Proceedings of a Symposium on Dose Rate in Mammalian Radiation Biology, Apr. 29–May 1, 1968, Oak Ridge, Tenn., USAEC Report CONF-680410, UT-AEC Agricultural Research Laboratory, July 12, 1968.
2. D. G. Brown, Clinical Observations on Cattle Exposed to Lethal Doses of Ionizing Radiation, *J. Amer. Vet. Med. Ass.*, **140**: 1051–1055 (1962).
3. D. G. Brown, R. A. Reynolds, and D. F. Johnson, Late Effects in Cattle Exposed to Radioactive Fallout, *Amer. J. Vet. Res.*, **27**: 1509–1514 (1966).
4. C. F. Tessmer, Radioactive Fallout Effects on Skin. 1. Effects of Radioactive Fallout on Skin of Alamogordo Cattle, *Arch. Pathol.*, **72**: 175–190 (1961).
5. R. A. Conrad, The Effects of Fallout Radiation on the Skin, in The Shorter-Term Biological Hazards of a Fallout Field, Dec. 12–14, 1956, Washington, D. C., G. M. Dunning and J. A. Hileken (Eds.), USAEC Report M-6637, pp. 135-141, U. S. Atomic Energy Commission and the Department of Defense, 1956.

6. M. M. Nold, R. L. Hayes, and C. L. Comar, Internal Radiation Dose Measurements in Live Experimental Animals—II, *Health Phys.*, **4**: 86–100 (1960).
7. M. C. Bell, Airborne Radionuclides and Animals, in *Agriculture and the Quality of Our Environment*, N. C. Brady (Ed.), pp. 77-90, Symposium No. 85, American Association for the Advancement of Science, Washington, D. C., 1967.
8. M. C. Bell, L. B. Sasser, J. L. West, and L. Wade, Jr., Effects of Feeding ^{90}Y -Labeled Fallout Simulant to Sheep, *Radiat. Res.*, **43**: 71–82 (1970).
9. H. Baxter, J. A. Drummond, L. G. Stephens-Newsham, and R. G. Randall, Reduction of Mortality in Swine from Combined Total-Body Radiation and Thermal Burns by Streptomycin, *Ann. Surg.*, **137**: 450–455 (1953).
10. L. A. George, Jr., P. L. Hackett, and L. K. Bustad, Triple Radiation Assault on Debilitated Lambs, USAEC Report HW-42540, General Electric Company, April 1955.
11. M. C. Bell and C. V. Cole, Vulnerability of Food Crop and Livestock Production to Fallout Radiation, Final Report, USAEC Report TID-24459, UT–AEC Agricultural Research Laboratory, Sept. 7, 1967.
12. J. S. Cheka, E. M. Robinson, L. Wade, Jr., and W. A. Gramly, The UT–AEC Agricultural Research Laboratory Variable Gamma Dose-Rate Facility, *Health Phys.*, **20**: 337–340 (1970).
13. M. C. Bell, Flexible Sealed ^{90}Sr – ^{90}Y Sources for Large Area Skin Irradiation, *Int. J. Appl. Radiat. Isotop.*, **21**: 42–43 (1970).
14. L. Wade, Jr., R. F. Hall, L. B. Sasser, and M. C. Bell, Radiation Dose to the Gastrointestinal Tract of Sheep Fed an Insoluble Beta-Emitter, *Health Phys.*, **19**: 57–59 (1970).
15. J. L. West, M. C. Bell, and L. B. Sasser, Pathology of Gastrointestinal-Tract Beta-Radiation Injury, this volume.
16. J. H. Rust, Report of the National Academy of Sciences Subcommittee for Assessment of Damage to Livestock from Radioactive Fallout, *J. Amer. Vet. Med. Ass.*, **140**: 231–235 (1962).
17. National Academy of Sciences–National Research Council, Damage to Livestock from Radioactive Fallout in Event of Nuclear War, Publication 1078, Washington, D. C., Dec. 20, 1963.
18. J. E. Johnson and A. I. Lovaas, Deposition and Retention of Simulated Near-In Fallout by Food Crops and Livestock. Technical Progress Report No. 1, Report AD-695683, Colorado State University, May 1969.
19. W. A. Rhoads, R. B. Platt, R. A. Harvey, and E. M. Romney, Ecological and Environmental Effects from Local Fallout from Cabrioleet. I. Radiation Doses and Short-Term Effects on the Vegetation from Close-In Fallout, USAEC Report PNE-956, EG&G, Inc., Aug. 23, 1968.

SIMULATED-FALLOUT-RADIATION EFFECTS ON LIVESTOCK

M. C. BELL, L. B. SASSER, and J. L. WEST

UT-AEC Agricultural Research Laboratory, Oak Ridge, Tennessee

ABSTRACT

Cattle ingesting ^{90}Y -labeled fallout simulant at the rate of 2 mCi/kg of body weight were more severely affected than those given 57,000 rads beta irradiation to 8% of the dorsal body surface. Whole-body irradiation of 240 R from ^{60}Co at 1 R/min affected only blood platelets and leukocytes. When these three treatments were combined on eight steers, all died within 54 days. Cattle were more sensitive to simulated-fallout radiation than sheep, but major damage from ingested radioactivity was in the rumen and abomasum of both species. No data were found on combined fallout-simulant effects on simple-stomach animals, but effects are predicted to be less than in ruminants. Sheltering cattle in barns would be the most effective practical measure to increase animal survival and reduce productivity losses in the survivors. Corraling animals to prevent their grazing heavily contaminated pastures would be an alternative where barns are not available. About 80% of the 112 million U. S. cattle are on pasture. In a 4-hr roundup time, it is estimated that this percentage could be reduced to 34% by corraling about 43 million cattle and by placing about 31 million in barns.

In the event of nuclear war, major farm livestock losses from airbursts would be caused principally by blast and thermal injury, whereas losses from surface bursts would be caused by fallout-radiation injury. Airbursts would be expected to be concentrated on urban areas and would not involve a large number of livestock, but fallout from surface bursts would probably include areas with heavy livestock populations. Grazing livestock would be exposed to gamma radiation to the entire animal, beta radiation to the skin, and beta radiation to the gastrointestinal tract. Most of the gamma exposure would come from ground fallout, but the total exposure would include the gamma component of fallout ingested and also from particles retained on the skin.

Early reports¹ indicated that beta irradiation was of little consequence in affecting livestock survival and production, but more-recent data show that,

owing to stratification of simulated fallout particles in the gastrointestinal tract, beta irradiation can severely affect survival and productivity of sheep.^{2,3} The early reports, based on dosimeter readings in dogs and goats fed soluble ⁹⁰Y, have recently been reconfirmed by Ekman, Funkqvist, and Greitz,⁴ who fed goats soluble ¹⁵³Sm and ¹⁴⁰La.

The purpose of this paper is to report the effects of simulated-fallout radiation on yearling beef calves and to predict the impact of fallout radiation on the livestock industry.

EXPERIMENTAL PROCEDURE

Sixty-four yearling Hereford steers averaging 184 kg were divided into eight groups and randomly assigned to the treatments listed in Table 1. Bilateral

Table 1
RADIATION-TREATMENT EFFECTS ON WEIGHTS AND
SURVIVAL OF YEARLING CATTLE

Treatment	Weights, kg		Deaths	
	Initial	After 5 weeks	No.	Days after treatment
Control	183.4* ± 6.9	198.9 ± 6.6	0	
WB	183.5 ± 5.9	193.5 ± 6.1	0	
Skin	186.4 ± 6.5	193.9 ± 6.2	0	
GI	184.3 ± 4.9	149.4 ± 6.5	3	14, 44, 61
WB + Skin	183.6 ± 5.7	189.1 ± 4.2	1	168
GI + Skin	184.8 ± 2.2	145.1 ± 4.4	4	25, 53, 67, 83
GI + WB	185.5 ± 4.9	141.5 ± 3.5	5	14, 17, 19, 40, 54
GI + WB + Skin	183.5 ± 5.3	135.5 ± 9.5	8	15, 19, 19, 25, 25, 27, 33, 54
Starved control	171.7 ± 7.4	155.7 ± 5.3	0	

*Mean values ± standard error.

exposure to whole-body gamma (WB) irradiation of an air dose of 240 R was made at a dose rate of 1 R/min with a ⁶⁰Co facility.⁵ Whole-body exposure was made 12 to 20 hr before the initiation of the other treatments. Exposure of about 8% of the body surface⁶ (Skin) to beta irradiation was accomplished by placing two flexible sealed ⁹⁰Sr—⁹⁰Y sources⁷ over the thoracolumbar region to give 57,000 rads at the surface of the hair at the rate of 17 to 25 rads/min. Gastrointestinal (GI) irradiation was accomplished by feeding 2 mCi of ⁹⁰Y-labeled sand per kilogram of body weight using the previously described procedure.² In addition to these three treatments and all possible combinations

of treatments, there was a control group and a group whose feed was restricted to that consumed by the GI group. One animal was exposed to each of the treatments at a time with eight replications over a period of 11 months. During a period of adjustment before treatment and for 5 weeks thereafter, the cattle were kept in individual stalls⁸ for separation and collection of urine and feces. During this time they were daily fed 2.7 kg of alfalfa pellets moistened with 0.8 kg of water. The ⁹⁰Y-labeled sand was mixed with the moistened alfalfa for each animal for three consecutive days. The ⁹⁰Y averaged 9.4 mCi/g of sand (88 to 175 μ) at the time of feeding. Steers weighing 184 kg were fed 368 mCi of ⁹⁰Y in 39 g of sand on day 1; this quantity had decayed to 284 mCi by day 2 and to 219 mCi by day 3. Control animals were fed the same quantity of nonradioactive sand for each of the 3 days. Feed intake, body temperature, and signs of radiation injury were recorded daily.

After 5 weeks of close observation in the collection stalls, the steers were grouped together by trial in large pens with shelter, access to limited pasture, and free access to grass hay, water, and trace-mineralized salt. In addition, they were fed enough 15%-protein grain mixture to provide a growth rate of about 0.4 kg daily for the control animals. Body weights and general recovery were observed periodically for 40 weeks after treatment.

In addition to these treatment groups, four yearling Hereford steers of comparable size and origin were implanted with glass-rod dosimeters into several segments of the gastrointestinal tract by a previously described procedure.⁹ After 3 weeks they were fed 2 mCi ⁹⁰Y sand for 3 days. They were subjected to necropsy 13 days later, and the recovered dosimeters were read.

Necropsy examinations were performed on all dead animals, and specimens of selected tissues were photographed and then preserved in 10% formalin for histological examination.

RESULTS

Table 1 shows that deaths occurred only in treatment groups including GI irradiation, with the exception of one steer that died 168 days after WB and Skin irradiation. Of the 20 deaths, 17 occurred within 60 days after treatment, and only 7 of the 17 occurred within 30 days. From these data it appears more reasonable to use LD_{50/60} than LD_{50/30} for grazing cattle exposed to combinations of fallout exposures.

Most of the early deaths were associated with combinations of GI and WB exposures with the resulting hemorrhagic necrotic involvement. Damage in the four major "pockets" of the rumen was more extensive than was observed in sheep. The rumen floor contained large fibrinous masses. In addition, sections of the ventral reticular honeycombs of most of the cattle were filled with a rubbery, yellow, glandular-appearing material. Minor fibrinous necrotic areas were seen in the omasum of most of the steers. Major areas of hemorrhagic necrosis were surrounded by edematous hyperemic laminae in the abomasum of

all cattle fed ^{90}Y . Adhesions among the rumen, abomasum, and reticulum were frequent, and some involved a mass of gelatinous serosal exudate. Gross lesions in the large intestine were restricted to minor areas in the cecum and colon of a few steers fed ^{90}Y sand. Several animals showed degenerative changes in the heart. Necropsy results are given in more detail in an accompanying paper.¹⁰

Data summarized in Table 1 also show that the combinations of radiation sources were more detrimental than single exposures not only to survival but also to body weight of the animals at 5 weeks after exposure. No animals given the combined GI + Skin + WB irradiation treatments survived longer than 54 days. At 35 days the three surviving steers had lost an average of 48 kg, which was the greatest loss by any treatment group. Only the "starved" control steers and the steers fed ^{90}Y sand lost weight. Although feed intake by the starved controls was restricted to that of the GI-treated steers, the GI-treated steers lost 25% of body weight, while the starved controls lost 9% and the normal controls gained 8%. The excess weight loss by the GI-treated steers was probably due to pyrexia and mild-to-severe diarrhea.

The depression in feed intake by the GI-treated steers was dramatic, but only minor differences were noted among the four groups fed ^{90}Y sand (these data are pooled in Fig. 1). After 9 days, feed intake averaged less than 5% of the controls for the remainder of the 28-day period of observation. Comparable data on sheep, also shown in Fig. 1, indicate that depression of feed intake occurred later and that appreciable recovery was evident by day 28. Feed consumption by cattle and sheep receiving WB, Skin, and WB + Skin treatments was not different from the untreated control animals for each respective species.

Since all cattle were group fed after 28 days of individual feeding, no feed data are available on the treatment groups after that time. Observations on the surviving cattle are incomplete at this writing, but the 40 weeks of observations

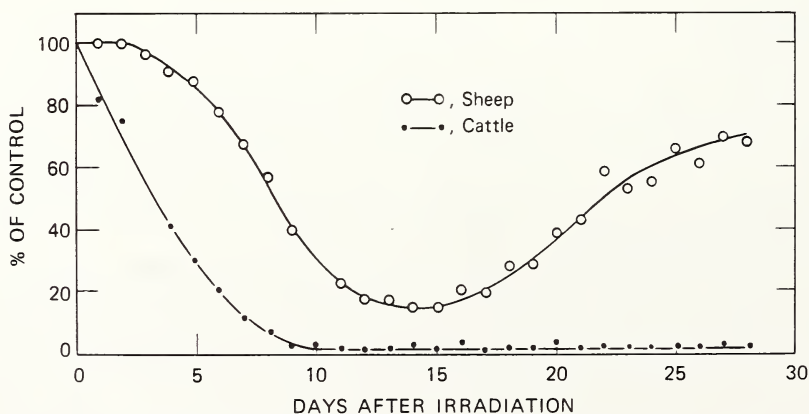

Fig. 1 Feed consumption by sheep and cattle fed ^{90}Y -labeled fallout simulant. Feed consumed by WB- and Skin-irradiated animals was the same as that consumed by controls.

are complete on four of the eight replications. During this period the average kilograms of weight gained per surviving animal for each treatment group were: control, 118; WB, 131; Skin, 66; GI, 48; Skin + WB, 58; GI + WB, 36; and GI + Skin, 22. None of the animals receiving GI + WB + Skin treatment survived beyond 54 days (Table 1). These data show that GI-treated survivors had regained much of the weight lost in the first 28 days (Table 1).

Body temperature was not significantly different among the controls, WB, Skin, and WB + Skin treatment groups for the 25-day postexposure period. All cattle fed ^{90}Y -labeled sand showed elevated body temperature, which persisted longer in those with combined GI and WB irradiation. The starved control group showed a drop in body temperature, indicating a lowered metabolic rate (Table 2).

Except for the larger exposure area, the skin irradiation changes developed similarly to those described by George and Bustad.¹¹ A moist reaction developed during the first 3 weeks, with crusted plasma and epilation in 8 to 12 weeks, followed by a hemorrhagic necrosis.

Whole-body gamma irradiation of 240 R at 1 R/min alone did not give the characteristic visible signs of radiation sickness. These animals did show the depression of white blood cells and platelets.

All steers fed ^{90}Y -labeled sand had mild-to-severe watery diarrhea. The onset of diarrhea varied from 6 to 15 days after initiation of the ^{90}Y feeding. In about half of the animals, this was followed by regurgitation of feed and water. Also about half of the animals were audibly grinding their teeth constantly. The loss of body fluids from diarrhea and vomiting probably contributed to the death of many of these animals.

DISCUSSION

General

The results of these investigations on simulated-fallout-radiation effects on beef cattle are similar to the data obtained on sheep.³ Nevertheless, there were differences in response between the two species which would prevent the exclusive use of sheep as models for beef cattle. Both species are grazing ruminants with many similar physiological functions, but they differ in size and grazing habits.

These data clearly demonstrate that cattle exposed to simulated-fallout grazing conditions were so severely affected by the combination of treatments that there were no survivors at nonlethal levels of WB exposure where no physical signs of radiation sickness were seen from WB exposure alone.

Skin Exposures

No deaths occurred from Skin exposure alone, but, in combination with other treatments, Skin exposure apparently contributed to increased mortality

Table 2
BODY TEMPERATURE OF CATTLE EXPOSED TO RADIATION TREATMENTS

Treatment	Days after irradiation				
	1 to 5	6 to 10	11 to 15	16 to 20	21 to 25
Control	101.9* ± 0.2	101.8 ± 0.2	101.7 ± 0.1	101.6 ± 0.2	101.9 ± 0.2
WB	102.1 ± 0.2	102.0 ± 0.2	101.7 ± 0.2	102.1 ± 0.2	102.1 ± 0.2
Skin	101.4 ± 0.2	101.7 ± 0.1	101.7 ± 0.1	102.0 ± 0.2	101.6 ± 0.2
WB + Skin	101.5 ± 0.2	101.7 ± 0.1	102.0 ± 0.1	102.4 ± 0.2	102.1 ± 0.2
GI	101.9 ± 0.3	103.0 ± 0.3	102.9 ± 0.2	102.1 ± 0.2	101.6 ± 0.2
GI + Skin	102.0 ± 0.2	103.2 ± 0.2	103.3 ± 0.2	102.4 ± 0.2	101.6 ± 0.2
GI + WB	101.4 ± 0.2	102.4 ± 0.2	104.4 ± 0.3	104.1 ± 0.4	103.2 ± 0.2
GI + WB + Skin	102.1 ± 0.2	102.4 ± 0.2	104.0 ± 0.3	104.6 ± 0.2	103.9 ± 0.2
Starved control	101.6 ± 0.2	101.1 ± 0.1	100.9 ± 0.2	101.2 ± 0.3	100.5 ± 0.2

*Mean Fahrenheit temperature ± standard error.

rates. Although the flexible, sealed sources exposed rectangular areas of 28 by 43 cm fairly uniformly, these areas resembled the beta-damaged areas on the Alamogordo cows.¹² Healing around the edges reduced the severely damaged area by the end of 40 weeks of observation. No data are available on the dimensions of the original damaged areas of the cattle exposed in 1945, but in 1950 hyperkeratosis was evident from the anterior withers to the tail head and extended up to about 23 cm laterally from the midline of one of these cattle. Some areas of extensive hyperkeratotic plaques and horns measured on the preserved hide taken from the same cow in 1960 were 13 by 10 cm with an elevation of about 2 cm over most of this surface. The skin exposure of the Alamogordo cattle was not uniform, but apparently some of these areas could have originally been as large and the damage as extensive as those seen on our cattle from the exposed rectangular areas of 28 by 43 cm. Some healing and tissue repair is already evident in the Skin-irradiated areas on the cattle, but the extensive hyperkeratosis has not developed in those exposed in July 1969. A few areas of moderate hyperkeratosis and scaling have developed.

Frequent insecticide spraying was required to reduce the fly problem on the skin-damaged areas during warm weather. Since these cattle had free access to shelter and shade, exposure to weather extremes was considerably reduced. Animals in other areas of the United States could be exposed to greater climatic extremes, and many would have much less protection. The loss of the dorsal hair coat covering 8% of the body surface would be expected not only to increase thermal losses but also to increase nutrient requirements for tissue repair. This is evident by the limited data showing that the Control steers gained 52 kg more than the Skin-irradiated steers during the 40 weeks of observation.

GI Exposure

Feeding steers 2 mCi of ⁹⁰Y sand per kilogram of body weight was more detrimental than feeding 2.4 mCi/kg to sheep. This was reflected in greater reduction of feed consumption, increased mortality, and increased organ damage. The reduction in feed intake was accompanied by a more severe diarrhea, vomiting, and grinding of teeth. Fallout-simulant feeding was calculated to represent a 9% forage retention with the calculation procedure described previously.¹ Since this corresponds closely to the level of 7% calculated for sheep,² the results were expected to be quite similar. Possibly cattle are more sensitive to GI beta irradiation, or perhaps the larger accumulation of ⁹⁰Y-labeled sand in the damaged areas produced a greater exposure. Dosimetry data are incomplete, but preliminary data indicate that the rumen exposure was greater than that observed in sheep.⁹

The long-term effects of GI exposure in cattle survivors appear to be less than in sheep. None of the surviving cattle developed rumen fistulae or abomasal hernia and prolapse, but six sheep fed ⁹⁰Y sand developed these sequelae. The greater thickness of cattle tissue probably reduced the eventual extent of

injurious effects on tissues adjacent to the primary site of injury, and no adhesions were found between affected organs and the abdominal wall.

These data show that feeding a particulate fallout simulant of size and density similar to early fallout produces results quite different from using soluble fallout simulants.^{4,13} Early fallout particles would be expected to collect in pockets in the gastrointestinal tract of ruminants as shown in this and similar studies.^{2,3}

WB Exposure

No cattle died from exposure to 240 R at 1 R/min unless this treatment was used in combination with other radiation exposures. Except for depressed white blood cells and blood platelets, none of these steers showed the depressed appetite and other symptoms of radiation sickness described by Brown.¹⁴ Brown established an $Ld_{50/30}$ of 543 R in a study of 70 adult female Hereford cattle exposed to 450 to 700 R at 0.9 R/min; about 10% of the cattle exposed to 450 R were lost. More-recent unpublished data from the same laboratory show a loss of five of 120 Hereford heifers exposed to 300 R at 0.7 R/min and no losses from 200 R exposure. None of these deaths occurred during the second 30 days after exposure, but four of the eight deaths from a combination of WB + GI + Skin exposures were observed in the first 30 days and the other four during the second 30-day period.

Animals surviving the WB component of fallout exposure of 240 R alone would be expected to produce almost as well as nonirradiated animals. During the 40 weeks of observation, the weight gain of the four WB-irradiated cattle averaged 131 kg, while the controls gained 118 kg. Data on other animals indicate life-shortening WB-irradiation effects, but, when aged cattle cease producing or production becomes uneconomical, they are normally culled and replaced by young breeding stock.

Combined Effects

Although no cattle died at a WB exposure of 240 R and all died from a combination of WB + GI + Skin, there are no data available for cattle on what might be expected from a different forage-retention level or from other combinations of exposures. It would be prohibitively expensive to obtain data on all possible combinations, but the need for more data is clearly indicated, and threshold lethality levels should be determined. These data show that combinations of two or more radiation injuries are lethal to a greater percentage of animals and severely affect productivity of survivors. Whole-body exposures affect the bone marrow as the most sensitive target system, and beta exposure to the skin and gastrointestinal tract affects the local tissue primarily, but abscopal effects are also observed on mineral metabolism.² Whole-body gamma radiation from ^{60}Co is reduced by 50% in about 18 cm of unit-density tissue, whereas

beta penetration from ^{90}Y is reduced by 50% by a thickness of only 1 mm of unit-density tissue.

IMPLICATIONS

Livestock Inventories

Since the 1967 report on livestock and postattack recovery,¹⁵ the inventory and productivity of the major classes of livestock have increased. Cattle number above 112 million and supply over 50 kg of meat and over 150 kg of dairy products per person in the United States annually. Production and consumption of pork and poultry products have also increased. With the increase in the livestock inventories, the estimated market value for cattle alone has now increased to over \$20 billion. This is indeed a food reserve worth evaluating in terms of reliable vulnerability estimates for fallout effects on survival and production of these animals. Cattle can produce highly nutritious food when fed products not usable for human consumption. However, if 90% of the breeding cattle were lost, about 11 years would be required to replenish the inventory of breeding animals;¹⁵ this further emphasizes the need to consider vulnerability and protective measures. In contrast, the inventory of poultry and swine is small; about 1 year is required to replenish a 90% loss of breeding stock.¹⁵ In even greater contrast is the radiation resistance and small inventory of seed grains required to resume normal production of food crops. These food crops are sensitive to fallout radiation only during the growing season, but livestock are sensitive at all seasons of the year.

The importance of livestock production in helping to improve world protein supplies has been reemphasized by Director General Boerma of the Food and Agriculture Organization of the United Nations in a new "Indicative World Plan." In the short run, he recommended that swine and poultry production be increased and that in the more distant future ruminant livestock inventories be built up to provide more meat and milk. Recommendations were made also to simultaneously increase production of cereals and crop products in the developing nations.¹⁶

Loss Predictions

In estimating survival of livestock populations in a nuclear war, most builders of damage-assessment models have used gamma radiation as the only criterion. Some estimate that, under the same conditions, half the human deaths will result from causes other than gamma irradiation. Soft targets, such as major cities, would probably get mostly airbursts, which would cause many thermal and blast fatalities among the population. Hard targets would be expected to be hit by surface bursts, which increase the fallout fatalities. Livestock are widely dispersed and would be affected mostly by fallout from surface bursts. Nevertheless, some losses would occur around population centers. In 1969 the

livestock yards in Chicago, Ill., handled 1.1 million cattle and 1 million hogs; those in Omaha, Nebr., handled 1.5 million cattle and 1.8 million hogs.¹⁷ Although marketing is being decentralized, many livestock are in transit through large population centers in addition to those destined for slaughter.

The limited data available in this and the preceding paper³ show definitely that, regardless of the conclusions based on dosimeter readings in animals fed soluble radioisotopes, grazing livestock losses from fallout radiation would not be limited to gamma irradiation alone. The 1970 Swedish paper⁴ based on dosimeter readings in goats given a solution of ^{153}Sm and ^{140}La neglects the physical characteristic of fallout particles in combination with the physiological functions of the ruminant gastrointestinal tract. Fallout particles from a surface nuclear burst deposited downwind on forage in an area where the gamma exposure would be above 200 R would be expected to collect in "pockets" in the rumen and abomasum owing to the strong muscular movements of the different compartments of these organs. This has been demonstrated not only by recovery of sand particles but also by observation of damaged areas and by dosimetry measurements. Radiation irritation to the colon would be expected to reduce the further beta exposure by increasing the rate of passage and by reducing water reabsorption in the lower large intestine. The reports from dosimeter readings in dogs and goats^{4,13} are from levels of soluble isotopes which showed minor to no physiological responses. Soluble isotopes would be expected to adsorb to feed particles and move in a homogeneous mixture with the ingesta. Early fallout levels apt to affect livestock survival would not be expected to have a solubility above 10%, but radiations from ^{153}Sm and ^{140}La appear to be characteristic of beta and gamma-ray emissions of mixed fission products. For animal research the gamma radiation from ^{153}Sm and ^{140}La would increase the hazard to personnel using these isotopes to label fallout-simulant sand particles, but the beta energy would be more characteristic of early fallout than that from ^{90}Y used in most other studies.

Data available on grazing livestock indicate that cattle are the most sensitive species to combinations of fallout exposures. Therefore damage-assessment estimates should concentrate on cattle since they supply more food products and require more time to replenish breeding stock than any other U. S. food source. Since there were no losses of cattle exposed to 240 R of gamma radiation but there was 100% loss of those exposed to 240 R of WB + GI + Skin irradiation, it is difficult to estimate the $\text{LD}_{50/60}$ gamma exposure when combined with the beta exposure. Based on the limited data available, very rough estimates of $\text{LD}_{50/60}$ exposures for livestock in barns and corrals or pens and for those grazing heavily contaminated pastures are presented in Table 3. Data on sheep represent a 7% forage retention of fallout with the combined effects being lethal to four of eight animals;³ data on cattle are for 9% forage retention with a loss of eight out of eight exposed animals. Apparently differences between these species are greater than can be accounted for by forage-retention differences. No data are available on cattle consuming forage at

Table 3

ESTIMATED LIVESTOCK LETHALITY ($LD_{50/60}$) FROM
FALLOUT-GAMMA-RADIATION EXPOSURE ALONE AND IN
COMBINATION WITH BETA RADIATION

	$LD_{50/60}$, total gamma exposure, R		
	Barn (WB)	Pen or corral (WB + Skin)	Pasture* (WB + Skin + GI)
Cattle	500	450	180
Sheep	400	350	240
Swine	640	600†	550†
Equine	670	600†	350†
Poultry	900	850†	800†

*Assumed forage retention of 7 to 9%.

†No data available.

the extremes of 5 to 25% forage retention reported by the Colorado workers¹⁸ using 88- to 175- μ sand. Also, no data are available on the effects of smaller radioactive fallout-simulant particles on the gastrointestinal tract of sheep or cattle.

Estimates in Table 3 on combined effects on swine, equine, and poultry were obtained, not from research results, but from estimates based on grazing habits and on gastrointestinal anatomical and physiological functions of these species.

To determine the number of animals which might be exposed, we can make assumptions on the different management practices for the classes of livestock within each species. A very rough estimate has been made of the normal numbers of the 112 million cattle expected to be on pasture, in penned or corralled areas, and in shelters (Table 4). The 4-hr roundup time does not imply that livestock producers would neglect other emergency procedures to protect livestock, but only what might be done in 4 hr to help protect cattle.

Removal from pasture offers the greatest protection to grazing livestock, as shown in Table 3. Pastured dairy cows are normally near the milking parlors and would be much easier to confine than other cattle. Milk cows and some calves creep-fed on pasture would get supplemental grain, and thus their intake of radioactive fallout would be diluted, but almost all other grazing cattle would depend entirely on pasture forages and mineral supplements. It would be futile to attempt to corral animals in the large range cattle operations in a short time, and 4 hr is insufficient time for many range operations. The operators of small family farms, which are typical of most of Tennessee farms, would be able to confine cattle in a short time. For this reason the surveys by Griffin¹⁹ are more optimistic than the data presented in Table 4. His pilot survey covered 176 farms in Tennessee, but no data were found for the entire United States. Again it should be emphasized that the greatest reduction in the number of lethalties can

Table 4
ESTIMATED NUMBERS OF U. S. CATTLE SHELTERED
OR CORRALLED INITIALLY AND AFTER A
4-HR ROUNDUP EFFORT

	Number in millions			
	Milk cows	Feedlot cattle	Other cattle	Total
Shelter				
No warning	3	< 1	1	5
4-hr roundup	8	3	20	31
Pen or corral				
No warning	4	10	4	18
4-hr roundup	5	8	30	43
Pasture				
No warning	7	1	81	89
4-hr roundup	1	< 1	36	38
Total	14	12	86	112

be made by preventing livestock from grazing for the first few days after fallout arrival (Table 3).

Productivity of Survivors

WB Effects

Gamma irradiation alone had no effect on rate of weight gain of cattle surviving exposure to 240 R at 1 R/min given as discussed previously, and no measurable effect was seen on the sheep exposed to the same treatments, as reported by Sasser, Bell, and West.³ Differences were not statistically significant, but WB-irradiated sheep gained 25 kg in 40 weeks, whereas controls gained 24 kg. These data are in agreement with earlier reports on swine,²⁰ minor effects on milk production,^{21,22} and minor effects on poultry.²³

Reproductive performance has not been affected in 179 surviving beef cows covering 8 years after an acute WB exposure, and offspring performance has not been different from control performance.²⁴ Embryos of food-producing animals exposed to a minimum of 100 R are sensitive to bone deformities for only 3 days during the first trimester of pregnancy.^{24,25}

WB + Skin Effects

Livestock surviving in open pens, corrals, and feedlots could receive sufficient exposure to affect productivity. The skin exposures of the cattle

discussed previously and those of sheep³ were sufficient to reduce weight gains, and the exposure levels were quite similar to those reported for the nonlethal exposure of cattle at Alamogordo in 1945.^{1,2} Skin-irradiated sheep gained 16 kg in 40 weeks; controls gained 24 kg. Observations are incomplete on cattle, but the 40-week gains (in kilograms) on four animals per treatment were: control, 118; WB, 131; Skin, 66; and Skin + WB, 58. All these animals had access to shelter; greater thermal losses would be expected under more-extreme environmental conditions. Skin irradiation at levels causing alopecia would also be expected to reduce milk production and increase problems from external parasites, which could also lower productivity and reduce survival.

WB + Skin + GI Effects

Livestock ingesting sufficient radioactive fallout to elicit a physiological response would almost always be expected to be exposed to WB and Skin irradiation levels sufficient to cause physiological changes. The four sheep surviving a combination of these three treatments recovered from the early weight loss, but the net 40-week gain was only 7 kg compared with 24 kg for the eight controls. No cattle survived a combination of these three treatments. Observations are continuing on the survivors of GI exposure alone and in combination with either Skin or WB. The conclusion is therefore made that grazing ruminants surviving in a fallout field where the gamma exposure is above 100 R would suffer a large reduction in productivity. No data are available on simulated exposure of grazing simple-stomach livestock, but effects would probably be less than in grazing cattle and sheep.

Protective Measures

Ideally, fallout shelters with high protection factors would save the most livestock from radioactive fallout in the event of a nuclear war. From a practical viewpoint, existing barns providing a protection factor of 2, as shown in the limited survey by Griffin,¹⁹ would offer protection much greater than that from the reduction in gamma exposure alone. Cattle in barns would probably survive a gamma contour (measured 1 m above the ground in the open) ten times greater than cattle grazing on pasture.

Cattle restricted to a small area with a high density of animals and limited or no grazing opportunity would have a much better chance of survival than those on pasture. They would provide mutual shielding against gamma exposure and, more important, would not receive the high-level GI exposure. In the USSR²⁶ it was suggested that canvas and blankets may be used to protect the skin of large animals. Also suggested was a chemically treated protective muzzle bag to be used on cattle to reduce inhaled fallout and to prevent them from eating contaminated feed.

Prevention of grazing of contaminated pastures for the first few days is one of the major ways of reducing lethality and productivity losses. Under these

conditions, giving cattle and sheep no feed at all is much better than permitting them to graze heavily contaminated pastures. Farm livestock can survive many days without feed but only a few days without water. Providing water for animals in barns and/or pens would be an additional problem.

ACKNOWLEDGMENTS

The UT-AEC Agricultural Research Laboratory is operated by the Tennessee Agricultural Experiment Station for the U. S. Atomic Energy Commission under Contract AT-40-1-GEN-242.

This work was supported by funds from the U. S. Office of Civil Defense and is published with the permission of the Dean of the University of Tennessee Agricultural Experiment Station, Knoxville.

REFERENCES

1. National Academy of Sciences—National Research Council, *Damage to Livestock from Radioactive Fallout in Event of Nuclear War*, Publication 1078, Washington, D. C., Dec. 20, 1963.
2. M. C. Bell, L. B. Sasser, J. L. West, and L. Wade, Jr., Effects of Feeding ^{90}Y -Labeled Fallout Simulant to Sheep, *Radiat. Res.*, **43**: 71–82 (1970).
3. L. B. Sasser, M. C. Bell, and J. L. West, Simulated-Fallout Radiation Effects on Sheep, this volume.
4. L. Ekman, B. Funkqvist, and U. Greitz, Beta- and Gamma-Dose Measurements in the Gastrointestinal Tract of Goats with LiF Dosimeters After a Single Intake of Simulant Mixed Fission Products, Report FOA-4-4418, The Research Institute of National Defense, Stockholm, Sweden, March 1970.
5. J. S. Cheka, E. M. Robinson, L. Wade, Jr., and W. A. Gramly, The UT-AEC Agricultural Research Laboratory Variable Gamma Dose-Rate Facility, *Health Phys.*, in preparation.
6. S. Brody, *Bioenergetics and Growth*, Reinhold Publishing Cooperation, New York, 1945.
7. M. C. Bell, Flexible Sealed ^{90}Sr – ^{90}Y Sources for Large Area Skin Irradiation, *Int. J. Appl. Radiat. Isotop.*, **21**: 42–43 (1970).
8. C. S. Hobbs, S. L. Hansard, and E. R. Barrick, Simplified Methods and Equipment Used in Separation of Urine from Feces Eliminated by Heifers and by Steers, *J. Anim. Sci.*, **9**: 565–579 (1950).
9. L. Wade, Jr., R. F. Hall, L. B. Sasser, and M. C. Bell, Radiation Dose to the Gastrointestinal Tract of Sheep Fed an Insoluble Beta-Emitter, *Health Phys.*, **19**: 57–59 (1970).
10. J. L. West, M. C. Bell, and L. B. Sasser, Pathology of Gastrointestinal-Tract Beta-Radiation Injury, this volume.
11. L. A. George and L. K. Bustad, Comparative Effects of Beta Irradiation of Swine, Sheep, and Rabbit Skin, in *Swine in Biomedical Research*, Proceedings of a Symposium, Richland, Wash., July 19–22, 1965, L. K. Bustad and R. O. McClellan (Eds.), USAEC Report CONF-650708, pp. 491–500, Battelle-Northwest.
12. D. G. Brown, R. A. Reynolds, and D. F. Johnson, Late Effects in Cattle Exposed to Radioactive Fallout, *Amer. J. Vet. Res.*, **27**: 1509–1514 (1966).
13. M. M. Nold, R. L. Hayes, and C. L. Comar, Internal Radiation Dose Measurements in Live Experimental Animals, *Health Phys.*, **4**: 86–100 (1960).

14. D. G. Brown, Clinical Observations on Cattle Exposed to Lethal Doses of Ionizing Radiation, *J. Amer. Vet. Med. Ass.*, **140**: 1051-1055 (1962).
15. M. C. Bell, Livestock and Postattack Recovery, in Proceedings of the Symposium on Postattack Recovery from Nuclear War, Fort Monroe, Va., Nov. 6-9, 1967, Report CONF-671135, pp. 43-58, Office of Civil Defense, Office of Emergency Planning, and National Academy of Sciences-National Research Council, April 1968.
16. A. H. Boerma, A World Agricultural Plan, *Sci. Amer.*, **223**: 54-69 (1970).
17. USDA Consumer and Marketing Service, Livestock Market News, **38**: 260 (Mar. 17, 1970).
18. J. E. Johnson and A. I. Lovaas, Deposition and Retention of Simulated Near-In Fallout by Food Crops and Livestock. Technical Progress Report No. 1, Report AD-695683, Colorado State University, May 1969.
19. S. A. Griffin, Vulnerability of Livestock to Fallout Radiation, in Annual Progress Report, Civil Defense Research Project, March 1968-March 1969, USAEC Report ORNL-4413(Pt. 1), pp. 94-96, October 1969.
20. R. S. Lowrey and M. C. Bell, Whole-Body Irradiation in the Young Pig: Growth, Hematology and Metabolism of ^{45}Ca and ^{89}Sr , *Radiat. Res.*, **23**: 580-593 (1964).
21. R. G. Cragle, J. K. Miller, E. W. Swanson, and D. G. Brown, Lactation and Radionuclide Metabolism Responses of Dairy Cattle to Lethal Doses of Gamma and Neutron Radiation, *J. Dairy Sci.*, **48**: 942-946 (1965).
22. E. W. Swanson, R. G. Cragle, and J. K. Miller, Effects of Irradiation upon Lactation, *J. Dairy Sci.*, **48**: 563-568 (1965).
23. D. K. Wetherbee, Gamma Irradiation of Birds' Eggs and the Radiosensitivity of Birds, Bulletin No. 561, USAEC Report TID-24521, Massachusetts Agricultural Experiment Station, October 1966.
24. UT-AEC Agricultural Research Laboratory, Annual Progress Report, Jan. 1-Dec. 31, 1968, USAEC Report ORO-672, October 1969.
25. B. H. Erickson and R. L. Murphree, Limb Development in Prenatally Irradiated Cattle, Sheep and Swine, *J. Anim. Sci.*, **23**: 1066-1071 (1964).
26. G. A. Malinin (Ed.), *Civil Defense in Rural Regions—A Textbook*, Military Publishing House of the USSR Ministry of Defense, Moscow, 1965. (STS Order No. 5666 for ORNL.)

PATHOLOGY OF GASTROINTESTINAL-TRACT BETA-RADIATION INJURY

J. L. WEST, M. C. BELL, and L. B. SASSER
UT-AEC Agricultural Research Laboratory, Oak Ridge, Tennessee

ABSTRACT

Fifty-five wether lambs of mixed breeding and seventeen yearling grade Hereford steers fed ^{90}Y -labeled sand as a fallout simulant developed characteristic lesions, particularly in the upper digestive tract. These changes occurred in selective areas in the stomach compartments. Typically there were large, friable, yellowish, elevated areas of fibrino-necrosis in the rumen sacs; areas of fibrino-necrosis or hemorrhagic necrosis in the reticulum; small hematomas, linear erosions, and focal yellowish necrotic exudate in the omasum; and areas of hemorrhagic necrosis in the abomasum. Healing occurred by scar-tissue formation. Scars in many instances had tags of necrotic exudate and/or superficial erosions months later. Changes in the reticulum and omasum were of appreciably higher incidence and severity in the steers than in sheep. Intestinal lesions were also of increased incidence and severity in steers as compared to sheep. Exposure of animals to beta skin-plaque irradiation in addition to feeding radionuclide did not significantly influence gastrointestinal-tract involvement, but whole-body irradiation exerted a definite additive effect. The conclusion that steers are more sensitive to the effects of the irradiation procedures employed than are sheep appears to be valid.

Livestock grazing in the area of a surface thermonuclear detonation would incur injury and/or death as the result of exposure to external gamma irradiation, skin-surface contamination with fallout beta particles, ingestion of fission products, or as combinations of these exposures. The extent of injury would depend on numerous factors, many of which have been discussed in the light of the possibilities of such an occurrence.¹⁻³

Nold, Hayes, and Comar,⁴ after feeding soluble ^{90}Y to dogs and goats, concluded that the lower large intestine was the critical organ. These observations were cited in a subsequent report¹ to serve as models for grazing animals. Ekman, Funkqvist, and Greitz⁵ found the highest beta concentration in the terminal colon of adult goats treated with a mixture of ^{153}Sm and ^{140}La .

The omasum was the organ severely damaged in the majority of sheep orally treated with soluble ^{144}Ce — ^{144}Pr ; injury to the rumen was found in only one animal. No changes were observed in the large intestines at levels that were lethal to about 25% of the sheep.⁶ Plutonium microspheres in gelatin capsules administered to miniature swine by stomach tube produced macroscopic necrotic and inflammatory areas in the lymphoid tissue at the ileo-cecal junction. Focal microscopic changes were detected throughout the small intestine.⁷ Clark reported that insoluble ^{90}Sr administered orally to pigs produced areas of damage in the ileum, cecum, and colon but that the principal lesions occurred in the stomach (see discussion of Ref. 7).

The paucity of information regarding the effects in ruminants resulting from the ingestion of radioactive fallout products and the necessity of these data for arriving at a more realistic evaluation of the results of a nuclear detonation prompted this study.

EXPERIMENTAL PROCEDURE

The experimental design for these studies has been previously described.⁹⁻¹¹ Of the experimental animals, 63 yearling wether lambs of mixed breeding, including 8 untreated controls, and 17 treated yearling Hereford steers were subjected to necropsy. Procedures involving the preparation and feeding of ^{90}Y -labeled sand were previously reported.⁹ Skin of the dorsal thoracolumbar region was beta irradiated by the method described by Bell¹² to expose about 8 and 12% of the body surfaces of steers and sheep, respectively. An estimated 57,000 rads was delivered to the exposed skin area in a 3-day period. In animals subjected to bilateral whole-body irradiation, an exposure of 240 R from ^{60}Co sources was delivered at 1 R/min. The number of sheep examined and the treatments were: 38 sheep fed 1.0 to 4.0 mCi of ^{90}Y -labeled sand per kilogram of body weight for 1 to 3 consecutive days; 7 sheep fed ^{90}Y -labeled sand and exposed to skin irradiation; 3 sheep fed ^{90}Y -labeled sand and exposed to whole-body irradiation; and 7 sheep subjected to a combination of the three treatments. Steers were similarly treated: 3 steers fed ^{90}Y -labeled sand at the rate of 2.0 mCi per kilogram of body weight for 3 consecutive days; 3 steers fed ^{90}Y -labeled sand and exposed to skin irradiation; 4 steers fed ^{90}Y -labeled sand and exposed to whole-body irradiation; and 7 steers subjected to the combined treatments.

Most of the animals were examined in extremis or promptly after death. Some animals were destroyed and examined several months posttreatment (PT). The day of postmortem examination indicates the time period between final treatment and examination; e.g., day 2 indicates that the animal was examined 48 hr after the last dose of ^{90}Y . Representative blocks of tissues were fixed in 10% buffered formalin, dehydrated in alcohol, mounted in paraffin, sectioned at $6\ \mu$, and routinely stained with hematoxylin and eosin or special staining procedures if conditions indicated.

RESULTS

General

In both ovine and bovine species, the most extensive pathologic changes occurred in the floor of the caudal half of the ventral ruminal sac (VRS). Frequently involvement of the VRS and posterior ventral blind sac (PVBS) was continuous. Changes in decreasing severity and extent were present in the anterior ventral blind sac (AVBS), the PVBS, and the posterior dorsal blind sac (PDBS) of the rumen. Frequently groups of papillae 2 to 5 cm in diameter in the vicinity of necrotic lesions were "matted" together or coalesced and were dull reddish gray and rather firm. Other individual papillae were enlarged and deep red, and the apex were shrunken and hard. The posterior wall and/or the floor of the reticulum was principally affected in cattle but was seldom affected in sheep. Omasal alterations were minor and involved the ventral or free aspects of the major laminae, usually adjacent to the reticulo-omasal orifice. In the abomasum the greater curvature of the caudal fundus and adjacent pylorus were the predominant sites of injury. Frequently the involvement extended for variable distances anteriorly between two or more fundic spiral folds. The mucosa was edematous, hyperemic, and frequently studded with petechial and ecchymotic hemorrhages. Spiral folds surrounding ulcers often had sloughed. Subserous hemorrhages and gelatinous infiltration occurred frequently, especially over mucosal lesions. Fibrinous and fibrous adhesions were commonly observed between organs and/or the abdominal floor. The entire thickness of the walls of the rumen, reticulum, and abomasum was affected in moderately severe and severe lesions.

Sheep

The severity of lesions was variable; usually lesions produced were proportional to the amount of radionuclide fed. The usual biologic variation, however, was observed.^{2,3,13}

Oral Treatment

No lesions were detected in sheep examined at days 0, 1, and 2. An ovoid, tan, elevated, necrotic plaque (3 by 4 cm) with several polypoidlike nodules around the periphery was observed in the VRS on day 3. Five smaller, soft, fluctuating, tan, polypoidlike nodules were in the floor of the PVBS. Similar ruminal changes were observed on day 5, and a few small hematomas involved two omasal laminae. Similar and somewhat more extensive changes were found in all ruminal compartments on day 6. A small tan nodule was observed in the reticulum. A few superficial erosions and ecchymotic hemorrhages were seen on a few omasal laminae. The abomasal mucosa was hyperemic, with a few lineal hemorrhages on the free borders of a few fundic spiral folds. An area of

hemorrhagic necrosis (3 by 4 cm) with a fibrinous exudate was observed in the caudal fundus. Ruminal changes were similar but more extensive by day 7, but the reticulum and omasum were unchanged. A large area of hemorrhagic necrosis involved the abomasum. On day 9 more extensive but similar ruminal involvement and a few yellowish nodules in the reticulum were observed. A few major omasal laminae had superficial linear erosions and a few adherent yellowish nodules. Abomasal changes were somewhat less severe than on day 7.

Similar but less extensive ruminal changes were observed on days 10 and 11. The reticulum and omasum were not affected. The abomasal mucosa and submucosa were markedly edematous and hyperemic with a small area (1 by 1.5 cm) of hemorrhagic necrosis. Ruminal changes on day 13 were similar to those observed on day 9, and there were no alterations in the reticulum and omasum. The abomasal mucosa was slightly hyperemic and edematous.

A Y-shaped, partially healed scar with scattered necrotic tags was observed in the AVBS on day 17. Fibrino-necrotic plaques in the other compartments were detaching at the edges or "rolling up", exposing granular hemorrhagic bases. Similar changes were seen on day 18, but the surface exposed by the detaching, friable, necrotic plaques was pale and smooth.

Similar ruminal changes were observed on day 21. An elliptical area of hemorrhagic necrosis in the abomasum was covered with a mottled, reddish-tan, fibrino-necrotic exudate. There was a moderate amount of sanguineous fluid and of clear, yellowish fluid in the abdominal and thoracic cavities, respectively. The lungs were expanded, heavy, reddish gray in color, and edematous.

Stellate bluish scars with scattered necrotic tags were seen in ruminal compartments on day 57. The caudal fundus and cephalic pylorus of the abomasum over an area measuring 7 by 10 cm were firmly adherent to the abdominal wall by dense fibrous tissue. An ulcer 4 cm in diameter extended almost to the skin. The skin overlying this area was cyanotic and rather firm. Sheep examined on days 72, 298, 307, 344, 365, and 372 had stellate, grayish-white, ruminal and abomasal scars. Several scars were studded with variable-sized superficial erosions.

The mucosa of the proximal duodenum was frequently congested and edematous. Changes in other portions of the intestines were insignificant.

Severe Complications

One sheep developed a ruminal fistula on day 132. A thick-walled, fistulous tract 3.5 cm in length and 1.5 by 2.5 cm in diameter extended from the anterior aspect of the posterior pillar of the VRS to the exterior, emerging about 1.3 cm anterior to the prepuce. The pillar was eroded. A deep ulcer surrounded by dense fibrous tissue was found in the adjacent PVBS. The rumen in this area was firmly adherent to the abdominal wall by fibrous connective tissue.

A soft, fluctuating, epilated, pendulous enlargement (4 by 6.5 cm) anterior and sagittal to the prepuce was observed in a sheep on day 66. The hernial sac

contained 5.5 by 6 cm of the caudal abomasal fundus. The abomasum was firmly attached to the hernial ring and a dirty yellow necrotic exudate covered the mucosa of the herniated tissue. A scar (3 cm) extended into the pylorus from the diverticulum. Eversion-type abomasal prolapse developed in three sheep on days 81, 169, and 201. A similar lesion developed on day 171 in a sheep that received combined oral and skin-plaque treatment. Since the caudal fundus was firmly adherent to the hernial ring by dense fibrous tissue, the cephalic pylorus constituted the major part of the prolapsed tissue. The prolapsed tissue was hyperemic, markedly edematous, and studded with superficial necrotic foci.

Oral and Skin-Plaque Treatment

Combined oral and skin-plaque treatment did not appear to influence significantly the extent of stomach changes; however, these animals were examined 171, 176, 315, 350, 439, and 447 days PT. It is of interest to note that the pericardial fluid was increased in these animals. Myocardial atony and dilated, thin-walled ventricles were associated with this finding.

Oral and Whole-Body Treatment

Three sheep exposed to combined oral and whole-body irradiation were examined 2, 15, and 365 days PT. The exudate of the ruminal lesions of the animal examined on day 15 was blood stained. A large area of hemorrhagic necrosis involved the abomasum (Fig. 1).

Oral, Whole-Body, and Skin-Plaque Treatment

Ruminal lesions of a sheep examined on day 19 following combined oral, whole-body, and skin-plaque irradiation were not increased in size, but the exudate contained a significant admixture of blood (Fig. 2). Three fistulous tracts originating from ruminal scars were found in a sheep examined on day 58. These tracts were surrounded by dense, reactive, fibrous tissue. Ruminal scars with superficial erosions were present in a sheep examined 419 days PT.

Steers

Oral Treatment

Steers fed ^{90}Y -labeled sand were examined 13, 42, and 59 days PT. The pharyngeal mucosa of one steer was moderately congested and edematous (day 13). Ruminal changes were grossly similar to those in sheep. These changes consisted of elevated, yellowish to yellowish-green, necrotic plaques frequently accompanied by polypoidlike masses of similar composition. Detachment of the friable necrotic exudate at the borders exposed a roughened, hemorrhagic surface (day 42). The necrotic plaques measured up to 12 by 21 cm and involved

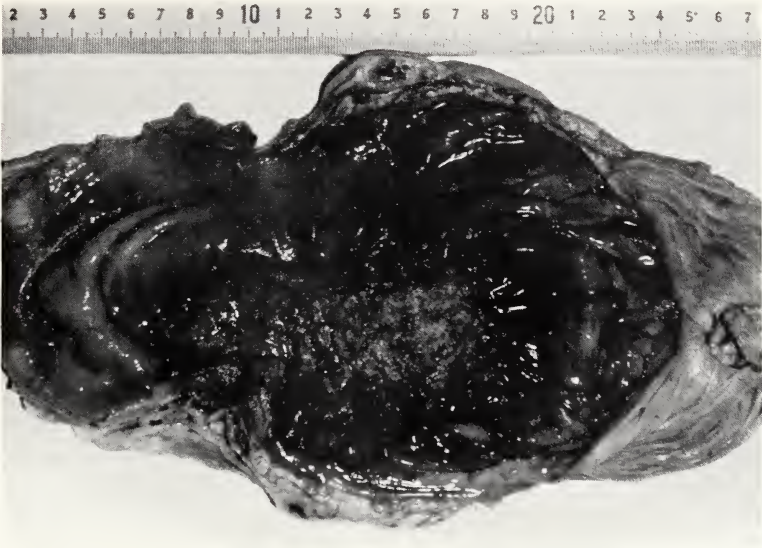

Fig. 1 Abomasum of sheep 41, 15 days after oral and whole-body irradiation. A 5.5- by 11-cm area of hemorrhagic necrosis involving the fundic-pyloric region. Spiral folds in the necrotic area have sloughed. The mucosa and submucosa of the entire organ is hyperemic, edematous, and focally hemorrhagic.



Fig. 2 Rumen and reticulum of sheep 10, 19 days after oral, whole-body, and skin-plaque irradiation. Rumen PDBS (left) fibrino-necrotic plaque; PVBS (lower left) fibrino-hemorrhagic-necrotic plaque; VRS (below) large fibrino-hemorrhagic-necrotic plaque; and AVBS (right) large area of fibrino-necrosis with a large hemorrhagic ulcer in the center. Reticulum (right) is normal.

the entire thickness of the wall. Gelatinous exudation, hemorrhage, and fibrinous or fibrous adhesions to adjacent organs (or less frequently to the abdominal wall) were seen. A tortuous, thick-walled, fistulous tract extended from the postero-medial floor of the VRS to the medial wall of the abomasum (day 59). Variable-sized scars partially covered with necrotic exudate were seen in the ruminal compartments. An area of necrosis (5 by 7 cm) was observed in the reticulum (day 13). A scar (1.5 by 17 cm) studded with small superficial erosions was observed on day 42. Omasal changes were limited to focal congestion of a few major laminae. An area of hemorrhagic necrosis (5 by 8 cm) involved the cephalic pylorus of the abomasum of one steer. The necrotic process had extended into the submucosa of the contiguous fundus (day 13). A tear-shaped scar (5 by 21 cm) with scattered necrotic tags was observed (day 42). The communicating fistulous tract (day 59) from the rumen entered the medial aspect of the terminal abomasal fundus. The spiral folds surrounding the tract had sloughed. A healed scar (3 by 7 cm) was seen in the caudal fundus. The surrounding mucosa was edematous and dirty brownish red in color.

Scattered areas of congestion were observed in the mucosa of the small intestine. A thickened area consisting of numerous nodules up to 1.5 cm in diameter was observed at the ceco-colic junction. The centers of some of the nodules contained yellow, necrotic plugs (day 42). The ileal and colic mucosae (and possibly the submucosa) of one steer were dull grayish red in color and appreciably thickened by transverse ridges (day 59).

An estimated 16 liters of sanguineous ascitic fluid containing yellowish fibrinous aggregates was seen in the steer examined on day 13. Fibrinous tags were adherent to the parietal and visceral peritoneum. Three liters of clear ascitic fluid was present in the steer examined on day 42.

Oral and Skin-Plaque Treatment

Ruminal changes were comparable to those in the previous group (days 20 and 51). Superficial erosions studded the scars of the animal examined on day 300. Depressed stellate scars (2 by 8 cm and 1.5 by 16 cm) were observed in the reticulum (days 20, 51, and 300). Linear erosions and small yellowish nodules of necrotic exudate were observed on some major omasal laminae (day 20). Variable-sized scars (12 to 21 by 2 to 4 cm) were observed in the wall of the greater curvature of the abomasum (days 20 and 51). The scars extended for several centimeters between five laminae (day 20). The surfaces of the scars were partially covered with yellowish-green necrotic exudate. There was a stellate scar (2 by 12 cm) in the caudal fundus and a second scar (1 by 11 cm) in the cephalic pylorus of the abomasum of the steer examined on day 300. Intestinal changes were comparable to those in the previous group.

Oral and Whole-Body Treatment

Elevated, linear and ovoid, dull gray, superficial erosions studded the mucosa of the thoracic portion of the esophagus of steers examined on days 17 and 37.

Ruminal involvement was of increased extent and severity, some plaques measuring 2.5 by 25 by 30 cm. In addition to the thick, yellowish or yellowish-green, friable plaques with polypoid masses (Fig. 3), there were elevated, yellowish areas covered with enlarged, sparse papillae. Some necrotic plaques (up to 5 by 12 by 14 cm) had completely detached and exposed a hemorrhagic granular surface. Necrosis of the reticulum was increased in extent and severity and consisted of large yellow or yellowish-green plaques and areas of hemorrhagic necrosis with sparse necrotic exudate (Fig. 3). Small linear erosions and focal, yellowish, necrotic plaques were observed on a few major omasal laminae in three steers. Abomasal changes were comparable to those in the previous group, the alterations consisting of large areas of hemorrhagic necrosis (Fig. 4) partially covered with yellowish, necrotic exudate (days 12, 15, and 17). The fundic spiral folds were moderately to markedly edematous with scattered ecchymotic hemorrhages. Deep erosions or ulcers occurred between several spiral folds. A scar with a hemorrhagic base was partially covered with cream-colored, necrotic exudate (day 37). The overlying serosa was congested, roughened, and covered with fibrino-hemorrhagic tags.

The duodenal mucosa was congested and edematous with small irregular and linear hemorrhages. Several gray and hemorrhagic nodules 4 to 5 mm in diameter had developed in the mucosae of the lower jejunum, ileum, and the midportion of the cecum (day 37).

Oral, Whole-Body, and Skin-Plaque Treatment

Superficial, grayish-red, linear streaks were observed in the esophageal mucosa (day 12). Changes in the rumen and reticulum were comparable to those in the preceding group. Omasal changes were similar but more extensive, consisting of linear erosions and hemorrhagic necrosis with necrotic exudate. The cavity of the omasum of one steer (day 17) was completely filled with a currant-jelly type of blood clot. There were areas of hemorrhagic necrosis (up to 8 by 28 cm) in the abomasum. The fundic spiral folds were edematous and hyperemic with scattered petechial and ecchymotic hemorrhages. A bluish, depressed, stellate scar (3 by 13 cm) was present in the abomasum of the steer surviving for 52 days.

The mucosa of the small intestine was congested, and in some there were ecchymotic hemorrhages in the wall (days 12, 16, 17, and 18). In one (day 17) several areas of hemorrhage (2 to 7 cm) in the wall with fibrino-hemorrhagic organizations attached to the mucosa were seen. There were fluid blood and blood clots in the lumina. In one steer an ulcer had developed in the mucosa over a large area of subserous hemorrhage (day 18). Cecal changes included scattered ecchymotic hemorrhages in the wall (day 17), solitary ulcers (days 18 and 31), a large ulcer over an area of submucosal hemorrhage (day 18), and an area (4 by 7 cm) with several small ulcers (day 31). The lumina of both the cecum and colon contained fluid blood and blood clots or bloody ingesta. The

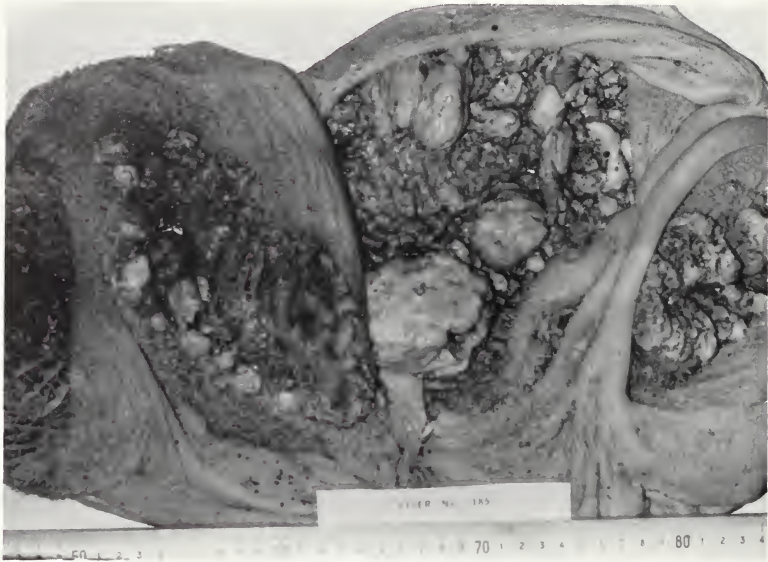

Fig. 3 Rumen and reticulum of steer 185, 17 days after oral and whole-body irradiation. Reticulum (left) with large area of hemorrhagic necrosis. Ruminal compartments (left to right), AVBS, VRS, PVBS, have necrotic plaques with variable-sized polypoidlike masses of exudate.

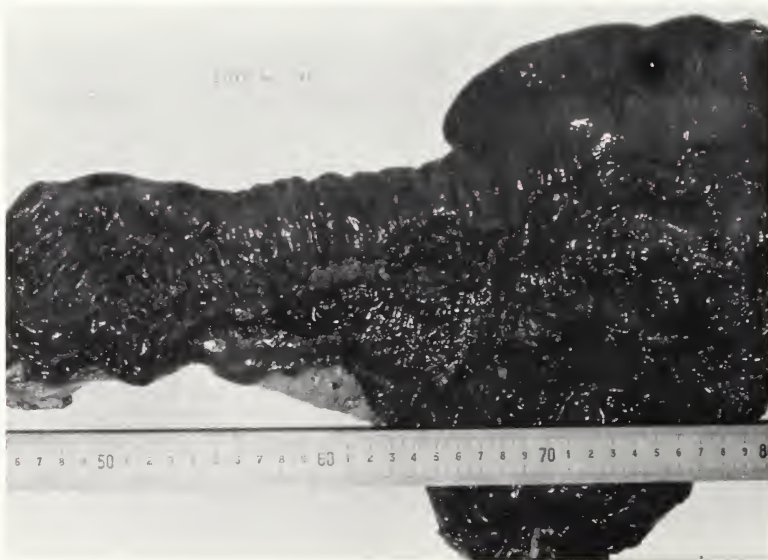

Fig. 4 Abomasum of steer 185, 17 days after oral and whole-body irradiation. A 7- by 19-cm area of hemorrhagic necrosis involving the fundic-pyloric region. Spiral folds in the area are necrotic and have sloughed. The mucosa and submucosa are hyperemic, edematous, and focally hemorrhagic.

mucosa was congested and studded with petechial and ecchymotic hemorrhages with similar hemorrhages being deeper in the wall.

Microscopic Observations

Preliminary microscopic observations are based on the examination of tissues from 12 sheep exposed to oral treatment only.

Days 1 and 2

Foci of "ballooning" or enlarged, rounded, pale staining cells were observed in the mucosae of the rumen and omasal laminae. There were a few foci of superficial necrosis of the abomasal mucosa.

Day 3

Small and larger microcysts formed by rupture of variable numbers of epithelial cells were seen in the ruminal mucosa. Although some cysts involved only the upper layers of cells, in larger cavities the entire epithelial thickness was affected. The cysts contained granular eosinophilic material and cellular debris. The eosinophilic material in many cysts was vacuolated. Larger cysts were covered by the parakeratotic layer only, but the upper border of some smaller cysts was composed of epithelial cells in addition to the parakeratotic layer. The cysts were primarily seen in the apical two-thirds of the affected papillae. The underlying propria was edematous and infiltrated with polymorphonuclear leucocytes (PMN cells). There were numerous areas consisting of groups of enlarged papillae. The lamina propria was edematous and contained strands of fibrin, and the submucosa was moderately edematous. Foci of necrosis, PMN-cell infiltration, and edema were seen in the abomasal mucosa. A slight fibrino-cellular exudate covered the necrotic surface.

Day 5

Focal sloughing of groups of necrotic ruminal papillae exposed the submucosa in some areas. Groups of several papillae were distended with plasma and fibrin; this situation created a honeycomb effect within the propria. There were large areas of fibrino-necrosis of the mucosa (Fig. 5). Hemorrhage and large numbers of PMN cells, many degenerating, occurred in the necrotic mass. The upper submucosa was moderately edematous and extensively infiltrated with PMN cells. The blood vessels were dilated, and the walls of some vessels were necrotic. The vascular endothelium was swollen, vacuolated, or hyperchromatic. In some vessels the endothelial cells were not evident. The deeper submucosa and circular muscle layer were slightly to moderately edematous and infiltrated with inflammatory cells.

There were foci of necrosis and sloughing of the omasal mucosa. The submucosa was moderately edematous and infiltrated with PMN cells. There were foci of hemorrhage. Large areas of hemorrhagic necrosis involved the abomasal mucosa. In some areas a thin layer of necrotic epithelium covered a thick layer of hemorrhage which appeared to rest on a thin rim of necrotic

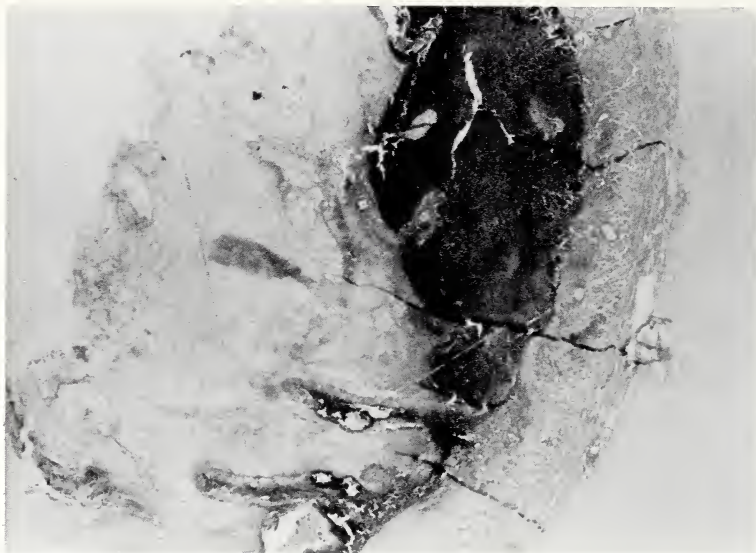

Fig. 5 Rumen of sheep 191, 5 days after oral treatment. Right to left, marked subserous edema. The mucosa is necrotic and covered with a thick fibrinous organization. Remnants of necrotic mucosa on the surface and two necrotic laminae propria (left lower center).

mucosa and the muscularis mucosae. It appeared that rapid and forceful hemorrhage had "lifted" the necrotic mucosa into the lumen. Blood vessels at the base of the mucosa and adjacent glands were dilated. Some of the vessels were characterized by necrotic walls and some by thrombosis. The muscularis mucosae was focally interrupted. The submucosa was markedly thickened by edema and hemorrhage and was extensively infiltrated with PMN cells. Some blood vessels in the upper submucosa had necrotic walls, and some of these vessels contained thrombi. The inner muscle layer bundles were separated by edema.

Day 9

There were large areas of fibrino-necrosis of the ruminal mucosa. Groups of papillae were distended with plasma containing fibrin. The submucosa beneath the large, necrotic, mucosal areas had necrosis and edema and only a few inflammatory cells. Numerous blood vessels in this area were necrotic and thrombotic. In other areas the submucosa was edematous, focally hemorrhagic, and extensively infiltrated with PMN cells. Focal necrosis of the inner muscle layer occurred beneath the more severely affected mucosa and submucosa.

Foci of superficial necrosis and large areas of hemorrhagic necrosis involved the abomasal mucosa (Fig. 6). A large fibrino-hemorrhagic organization was

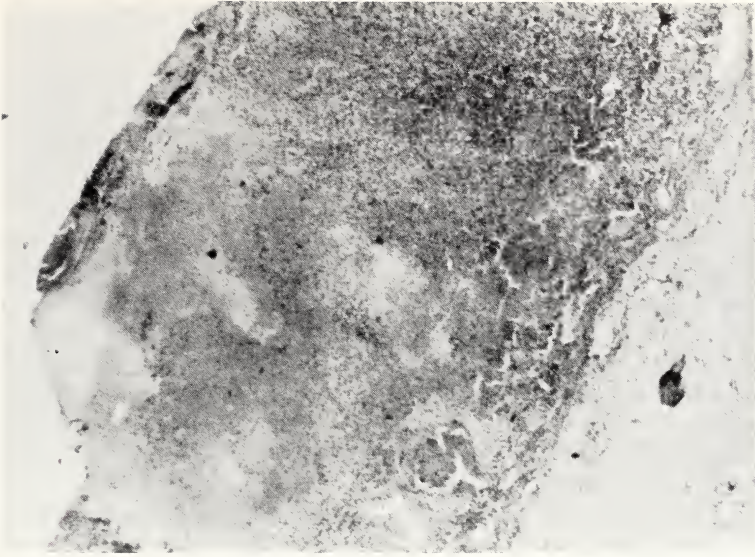

Fig. 6 Abomasum of sheep 175, 9 days after oral treatment. Right to left, extensive submucosal edema and focal hemorrhage. Necrosis and interruption of the muscularis mucosa. Hemorrhagic necrosis of the mucosa with dilated, necrotic, and thrombosed vessels at the base of the mucosa. The surface of the hemorrhagic-necrotic exudate is covered with a thin layer of necrotic mucosa.

attached to the surface in one area. Other changes were similar to those found on day 5.

Day 11

Large areas of fibrino-necrosis of the ruminal mucosa were covered at some sites by necrotic epithelium and the parakeratotic layer. The latter was quite well preserved. Epithelial cells bordering the necrotic areas were enlarged and rounded and the nuclei were pyknotic. Some rete pegs were irregular in shape and of increased length. The underlying propria was edematous and extensively infiltrated with PMN cells. The submucosa was moderately edematous and focally hemorrhagic. There was a moderate infiltration of PMN cells with fewer lymphocytes and mononuclear cells. Collagen fibers in the upper submucosa were anuclear, swollen, and dull red, and some fibers were "frayed." The walls of some blood vessels were necrotic, and some vessels were thrombotic. The abomasal changes were comparable to those observed on day 9.

Days 13 and 18

The changes were similar to those found on day 11.

Day 59

The lining of large areas of the rumen consisted of a mixture of vascular granulation tissue and fibroblasts. The fibroblasts were oriented parallel to a

surface that was "ragged" and superficially necrotic. The underlying collagen fibers were swollen. In other areas a layer of dark epithelium with a thickness of two to three cells formed the inner lining. The undulant surface had no papillae. Rete pegs were absent, sparse and short, or sparse, long, and irregular. The edematous submucosa was extensively infiltrated with macrophages. Several blood vessel walls were eccentrically thickened.

Changes in the abomasal mucosa included dilated glands, glandular atrophy, atrophy and glandular degeneration with moderate mononuclear infiltration and slight infiltration of lymphocytes and PMN cells, focal superficial necrosis, necrosis of the entire mucosa, and ulcer formation. A few colonies of large bacterial rods were seen beneath the necrotic mucosa. A large area of the submucosa forming the base of the ulcer was replaced by vascular granulation tissue and fibroblasts. This tissue was moderately infiltrated with macrophages and PMN cells. Coagulation necrosis involved another large area of the submucosa beneath the ulcer. Several dilated, necrotic, and thrombosed vessels were seen in this area. A band of caseous necrosis involved the lower submucosa and a portion of the thin muscle layer. The atrophic muscle layer rested on a thick layer of collagenous fibers and contained islands of granulation tissue and fat. Skin was not present on the sections.

DISCUSSION

Regressive cellular changes and cellular necrosis produced by irradiation are not pathognomonic.^{1,3-15} Similar changes have been produced by a variety of causes.^{1,3} The exact mechanism or mechanisms by which cellular changes are produced by irradiation are not known but are probably multiple.^{1,3-15}

The pharyngeal mucosa and submucosa were congested and edematous, and the esophageal mucosa of a few steers had linear and ovoid erosions. It is probable that these changes occurred during regurgitation of ruminal fluids rather than as a consequence of ingestion of feed containing the radionuclide.

Yttrium-90-labeled sand ingested by sheep and cattle collects in rather specific ruminal and abomasal sites and produces characteristic pathologic lesions. Sand particles lodge between ruminal papillae in these areas and appear to be indefinitely retained by the ensuing inflammatory and necrotic exudate. Ruminal contractions and compartmentalization by the pillars probably are important in determining the areas where radioactivity will be concentrated. In a few early lesions, focal accumulation of plasma beneath and within the mucosa resulted in dome-shaped, yellowish elevations sparsely covered with enlarged papillae. Later, necrosis of the mucosa, increased vascular damage, extensive effusion of plasma, and extensive inflammatory cell infiltration produced the characteristic large fibrino-necrotic plaques or masses observed in sheep. Probably the grossly similar lesions seen in cattle would be comparable microscopically. Detachment of the necrotic masses at the borders exposed a

hemorrhagic, granular base or a smooth, pale surface, the appearance depending upon the age of the lesion. A pale, depressed, stellate scar was apparent on detachment of the exudate. Several months after treatment necrotic tags and superficial erosions were seen on the surfaces of numerous scars.

The reticulum was mildly affected in a few sheep. In contrast, necrotic plaques or areas of hemorrhagic necrosis were seen in the reticulum of a significant number of steers. We have no explanation for this species difference.

In general, minor lesions only were seen in the omasum of a few sheep. In steers the changes were of appreciably greater incidence and severity. The omasum of one steer was filled with a currant-jelly blood clot. An area of hemorrhagic necrosis between two laminae had apparently eroded into a large blood vessel.

Characteristically injury occurred at the fundic—pyloric region on the greater curvature of the abomasum. This selective location is probably due to gravitational forces, the sand particles settling in the lowest area of the organ. Several variable-sized extensive areas of hemorrhagic necrosis developed in this area. Some lesions were covered in part with a thick fibrino-necrotic exudate.

Anorexia (in the absence of more-severe complications) following treatment for variable periods resulted in appreciable weight loss. Ruminal fistula, abomasal hernia, and eversion-type abomasal prolapse occurred in six sheep. Another sheep probably would have developed an abomasal fistula if it had survived. Fibrinous and fibrous adhesions of organ to organ and/or to the abdominal floor occurred frequently in sheep. Similar adhesions between organs were frequently seen in steers. Only two steers developed ruminal adhesions to the abdominal floor. In one steer a long, tortuous, communicating fistulous tract extended from the rumen to the abomasum. The cause of this development is obscure. Fibrous adhesions of organ to organ or to the abdominal floor would interfere with normal function and conceivably could result in strangulation. Transportation and other stress-producing experiences may cause separation of adhesions and subsequent peritonitis.¹⁶

The absence of significant intestinal lesions in sheep was unexpected. Intestinal lesions found only in orally treated steers were not severe. The ileal, cecal, and colic mucosae (and possibly submucosae) of the intestine of one steer were appreciably thickened by transverse ridges. This change was not believed to be associated with irradiation, but microscopic examination has not been completed.

Whole-body irradiation superimposed on oral treatment appeared to increase the extent and severity of gastrointestinal changes.

Focal microcyst formation and foci of epithelial necrosis were early ruminal mucosal changes. Microcysts were probably the result of cellular imbibition of fluid and subsequent rupture of the cells. The cysts were frequently multiple on papillae and involved the apical portions of the affected papillae. The underlying lamina propria was edematous and infiltrated with numerous PMN cells. Microcysts, which are not an unusual ruminal mucosal change in sheep,

apparently occur as a result of altered physiology.⁸ These cysts are not associated with inflammation of the lamina propria. Focal effusions of plasma into the mucosa caused marked swelling of groups of papillae. The epithelium of these papillae was degenerative or focally necrotic. The propria was distended with proteinaceous fluid and fibrin; this distention created a honeycomblike effect.

In more advanced lesions large areas of fibrino-necrosis involved the mucosa. This exudate consisted of necrotic mucosa, fibrin, and extensive PMN-cell infiltration. In some areas the exudate had sloughed and exposed a congested, ragged submucosa. The submucosa was edematous, focally hemorrhagic, and extensively infiltrated with PMN cells. The blood vessels were dilated. Many were necrotic and several thrombosed. The necrotizing reaction extended to the serosa in more severely affected areas. The inner surface of a ruminal scar was formed by granulation tissue and fibroblasts or a thin (2- to 3-cell thickness) layer of hyperchromatic epithelium with no or with scattered, short rete pegs. The submucosa was edematous and extensively infiltrated with macrophages.

Minor changes of focal necrosis of the omasal mucosa with edema and cellular infiltration of the submucosa were seen.

Hemorrhagic necrosis was the characteristic change seen in the abomasal mucosa. The submucosa was markedly edematous and focally hemorrhagic. Many blood vessels were necrotic and thrombosed. In one animal a chronic ulcer had developed. The underlying submucosa was replaced in one area by vascular granulation tissue and fibroblasts, which were infiltrated with PMN and mononuclear cells. A large area of coagulation necrosis involved an adjacent area of the submucosa beneath the ulcer, indicating concomitant repair and continuation of an acute reaction.

Intestinal changes in sheep were minimal. Comparable treatment of cattle induced significant lesions. Bacterial invasion of tissue was observed in only a few animals. The conclusion that sheep are less sensitive to the radiation procedures employed than are cattle appears to be justified.

ACKNOWLEDGMENTS

The UT-AEC Agricultural Research Laboratory is operated by the Tennessee Agricultural Experiment Station for the U. S. Atomic Energy Commission under Contract AT-40-1-GEN-242.

This work was supported by funds from the U. S. Office of Civil Defense and is published with the permission of the Dean of the University of Tennessee Agricultural Experiment Station, Knoxville.

REFERENCES

1. National Academy of Sciences-National Research Council, Damage to Livestock from Radioactive Fallout in Event of Nuclear War, Publication 1078, Washington, D. C., Dec. 20, 1963.

2. J. H. Rust, Report of the National Academy of Sciences Subcommittee for the Assessment of Damage to Livestock from Radioactive Fallout, *J. Amer. Vet. Med. Ass.*, **140**: 231-235 (1962).
3. H. A. Smith and T. C. Jones, *Veterinary Pathology*, pp. 658-673, Lea & Febiger, Philadelphia, 1966.
4. M. M. Nold, R. L. Hayes, and C. L. Comar, Internal Radiation Dose Measurements in Live Animals, *Health Phys.*, **4**: 86-100 (1960).
5. L. Ekman, B. Funkqvist, and U. Greitz, Beta- and Gamma-Dose Measurements in the Gastrointestinal Tract of Goats with LiF Dosimeters After a Single Intake of Simulant Mixed Fission Products, Report FAO-4-4418, The Research Institute of National Defense, Stockholm, Sweden, March 1970.
6. M. C. Bell, Airborne Radionuclides and Animals, in *Agriculture and the Quality of Our Environment*, N. C. Brady (Ed.), pp. 77-90, Symposium No. 85, American Association for the Advancement of Science, Washington, D. C., 1967.
7. V. H. Smith, H. A. Ragan, B. J. McClanahan, J. L. Beamer, and J. L. Palotay, The Passage Time of Plutonium Oxide in Pigs, in *Gastrointestinal Radiation Injury*, M. F. Sullivan (Ed.), Report of a Symposium held at Richland, Wash., Sept. 25-28, 1966, Report CONF-660917, pp. 518-523, Excerpta Medica Foundation, New York, 1968.
8. Alfred Trautmann and Josef Fiebiger, *Fundamentals of the Histology of Domestic Animals*, pp. 182-183, Translated and revised from the eighth and ninth German editions, 1949, by Robert E. Habel and Ernst Biberstein, Comstock Publishing Associates, Ithaca, N. Y., 1952.
9. M. C. Bell, L. B. Sasser, J. L. West, and L. Wade, Jr., Effects of Feeding ^{90}Y -Labeled Fallout Simulant to Sheep, *Radiat. Res.*, **43**: 71-82 (1970).
10. L. B. Sasser, M. C. Bell, and J. L. West, Simulated-Fallout-Radiation Effects on Sheep, this volume.
11. M. C. Bell, L. B. Sasser, and J. L. West, Simulated-Fallout-Radiation Effects on Livestock, this volume.
12. M. C. Bell, Flexible Sealed ^{90}Sr - ^{90}Y Sources for Large Area Skin Irradiation, *Int. J. Appl. Radiat. Isotop.*, **21**: 42-43 (1970).
13. W. A. D. Anderson, *Pathology*, Vol. I., pp. 166-188, The C. V. Mosby Company, St. Louis, Mo., 1966.
14. A. R. Moritz and F. W. Henriques, Jr., Effects of Beta Rays on the Skin as a Function of the Energy, Intensity, and Duration of Radiation. II. Animal Experiments, *Lab. Invest.*, **1**: 167-185, 1952.
15. Philip Rubin and G. W. Casarett, *Clinical Radiation Pathology*, Vol. I, pp. 1-37, W. B. Saunders Company, Philadelphia, 1968.
16. K. Nieberle and P. Cohrs, *Textbook of the Special Pathological Anatomy of Domestic Animals*, revised by Paul Cohrs, translated by R. Crawford, pp. 364-369, Pergamon Press, Inc., London, 1967.

RESPONSES OF LARGE ANIMALS TO RADIATION INJURY

DAVID C. L. JONES
Stanford Research Institute, Menlo Park, California

ABSTRACT

Recent data pertaining to the relations between dose rate and lethality in sheep exposed to dose rates ranging from high (hundreds of roentgens per hour) to low (less than 1 R/hr) are incorporated in a review of the field. It is concluded that even within the high dose-rate range there is a significant inverse relation between $LD_{50/60}$ and dose rate and that discernible radiation injury does accrue even at dose rates less than 1 R/hr. The chronology of lethality and hematologic changes in sheep during continuous exposure to death at dose rates of 3.74 and 1.96 R/hr are compared with those observed during terminated exposure at 0.84 R/hr. At 1.96 R/hr there is no indication of reduction in survival time by overirradiation, whereas at 3.97 R/hr there is a marked compression in the range of survival times. Chronology and extent of changes in circulating leukocyte counts vary appreciably with dose rate during protracted exposure.

In April 1968, at the symposium on dose rate in mammalian radiation biology,¹ Dr. Norbert Page gave an overview of the effects of dose protraction on radiation lethality in large animals. His summary, together with some other papers presented at that symposium, furnished an excellent statement of the state of the art at that time. In his summary of the entire symposium, Edward Alpen pointed up the importance of describing the effects of variation in dose rate in considering recovery processes and the untenability of the view that a single unique recovery "constant" exists, even for a given species.

My objective is to update the information presented at the 1968 symposium, with particular reference to the sheep. This species is of major interest to this present symposium because the sheep is an economically important domestic animal resource and because it is the large animal that has been most systematically studied with respect to the relations between dose rate and response to radiation.

The information presented comes principally from the most recent technical reports of the Naval Radiological Defense Laboratory (NRDL) program in large animal radiobiology, published during the last months of that laboratory's existence, and from the initial studies under the Office of Civil Defense (OCD) program now located at the Stanford Research Institute (SRI).

Two specific areas are considered: (1) the relation between dose rate and the $LD_{50/60}$ as measured in the terminated type of exposure to a predetermined dose and (2) the relation between dose rate and mortality and hematological responses during continuous exposure to death.

$LD_{50/60}$ AS A FUNCTION OF DOSE RATE

The $LD_{50/60}$ for animals exposed to high dose rates is of interest from two standpoints: Lethality does appear to vary with dose rate even within the range of high dose rates usually described as "acute," and the response to high-dose-rate exposure is used as the standard against which responses to low-dose-rate exposure are compared. For example, one standard way of comparing recovery after, or even during, a low-dose-rate exposure is to compare the $LD_{50/60}$ at a high dose rate in animals previously exposed at the low dose rate with that of previously unexposed, comparable animals. The difference between the two $LD_{50/60}$'s is considered to represent the residual injury remaining from the initial low-dose-rate exposure, and the difference subtracted from the dose given at the low dose rate represents the amount of recovery that has occurred.

Figure 1 summarizes the available information on $LD_{50/60}$ in sheep (California-bred wethers) exposed to dose rates ranging from 30 to 660 R/hr (midline air). All exposures were bilateral (1 MVp X ray) or quadrilateral (^{60}Co), and the two types of radiation sources have been shown to have similar depth-dose characteristics.² The data from Refs. 2, 3, and 7 were included in Page's 1969 presentation. Since that time there have been five more determinations of the $LD_{50/60}$ at dose rates in excess of 30 R/hr—two at SRI, two at NRDL,^{4,5} and one at the Air Force Weapons Laboratory.⁶ The composite of the data of Hanks et al. reported in 1966 and the data of some additional groups reported in 1969 by Taylor et al.³ changed the original estimate of 252 R to 258 R. One can question whether the 30 R/hr value of Page et al. is a part of the high-dose-rate continuum. It is included here because the exposures took less than a day and because its fit with the protracted dose-rate $LD_{50/60}$ data to be considered is even less apparent. When plotted on a graph, these nine data points appear to be adequately fitted by a linear regression (correlation coefficient, -0.82) expressed by

$$Y = 356 - 0.156 X \quad (1)$$

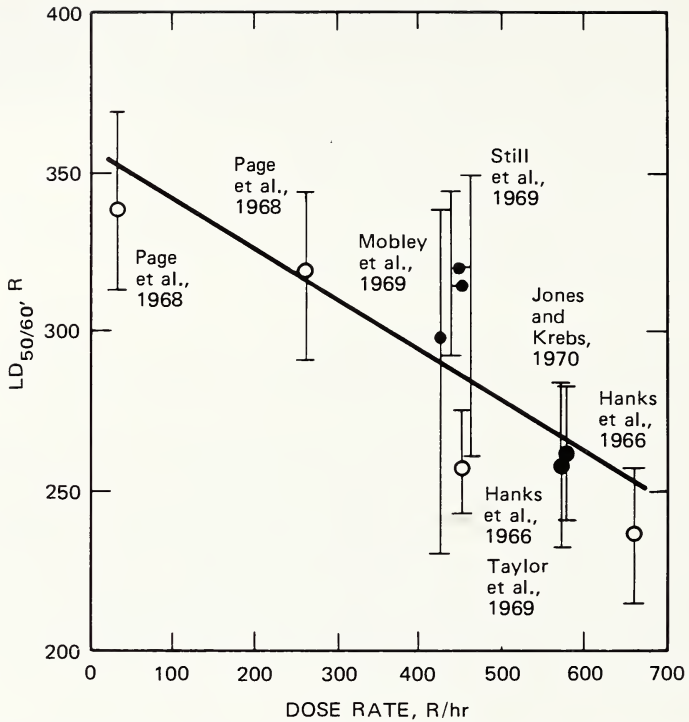

Fig. 1 Relation between $LD_{50/60}$ (midline air) and dose rate in sheep exposed at a high dose rate.

where Y is the $LD_{50/60}$ in roentgens and X is the dose rate in roentgens per hour. Since the 95% confidence interval of the slope (0.093) is less than the computed slope itself (0.156), there is a significant variation of $LD_{50/60}$ with variation in dose rate. Thus, even at dose rates in the so-called acute range, it appears that we should specify the dose rate precisely when describing the $LD_{50/60}$, and, in using acute dose-rate responses to evaluate injury accumulation and recovery at protracted dose rates, we should take into account this variation.

Figure 2 summarizes the presently available $LD_{50/60}$ information for protracted dose rates where the exposure time is of the order of days or weeks. Results of the work by Jones and Krebs, which is currently in progress at SRI, are not sufficient to provide any reliable estimate of the confidence limits for the computed $LD_{50/60}$ at 0.84 R/hr, since there were only three deaths among the five groups of 12 animals exposed. The computed $LD_{50/60}$ of 1084 R is based on one death after exposure at 777 R, one at 837 R, and two at 897 R (the highest dose tested). Evaluation of the characteristics of the relation between dose rate and $LD_{50/60}$ from about 4 R/hr on down appears to be unwarranted until further information is acquired. That there is a tremendous

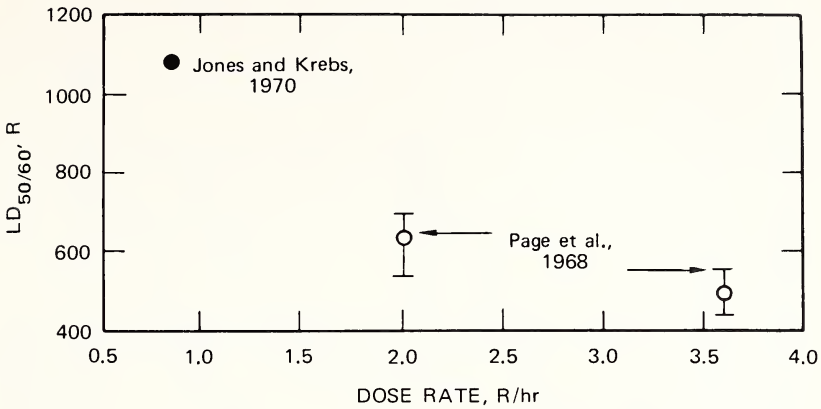

Fig. 2 Relation between LD_{50/60} (midline air) and dose rate in sheep exposed at a low dose rate to ⁶⁰Co gamma radiation.

change in LD_{50/60} as compared with acute dose rates is, of course, quite apparent. It may even be that below some dose rates (presumably less than 1 R/hr) the conventional statistics relating exposure dose and mortality do not apply.

CONTINUOUS EXPOSURE TO DEATH

Figure 3 summarizes lethality and exposure data for the two relatively recent studies of lethality and hematologic changes during continuous (23 hr/day) protracted exposure to death. The first of these was done by Still et al.⁸ at NRDL, and the second was done at SRI. At 1.96 R/hr the first death occurred on the 25th day of exposure, the median survival time was 42.5 days, and the last animal died on day 60. Deaths were spread out more or less uniformly throughout the period from days 25 to 60. At 3.79 R/hr, however, there was a marked difference in the lethality pattern. The first death occurred slightly earlier, on day 22, and all the remaining animals died within the next 6 days, the median survival time being 24.5 days. With continuous exposure to death, we are always faced with the concept of irradiation after accrual of a dose lethal to the individual animal. From Fig. 3 it appears that the effect of this so-called "wasted radiation" is a function of the dose rate. At 3.79 R/hr, further exposure after accrual of a potentially lethal dose results in a compression of survival time. It is as though at this dose rate there are no "low-lethal" doses, and animals die with survival times similar to those observed after doses in the high-lethal range for acute exposure. For example, the work of Page et al.⁷ indicates that the LD_{50/60} for terminated exposure at 3.6 R/hr is 495 R. In continuous exposure at 3.79 R/hr, this dose was accrued in 5.7 days. Subtracting this from the mean survival time of 24.7 days gives a survival time after accrual of an LD_{50/60} of

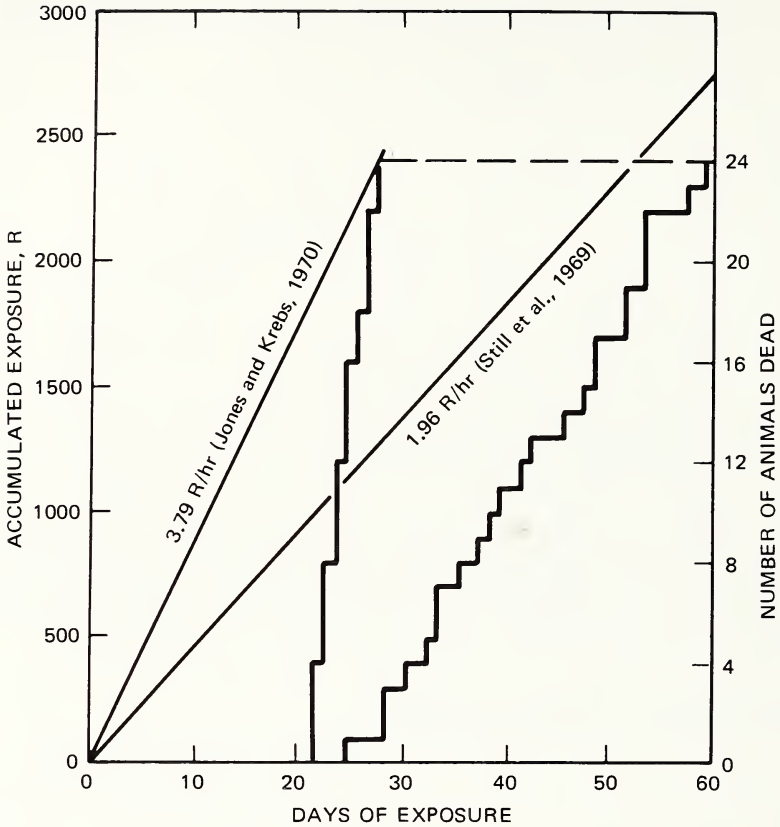

Fig. 3 Cumulative mortality and dose in sheep exposed continuously (23 hr/day) until death at 1.96 or 3.79 R/hr (midline air). Values for 1.96 R/hr are estimated from the data of Still et al.

19 days. This is approximately the value that is typical of survival time when the exposure is near the $LD_{50/60}$ for dose rates of the order of 450 to 600 R/hr. In continuous exposure at 1.96 R/hr, however, there is no discernible compression of the range of survival times. Again, Page et al.⁷ found that the $LD_{50/60}$ for 2.0 R/hr (terminated exposure) is 637 R. At 1.96 R/hr this dose is accrued in 14.1 days. Subtracting this value from the mean survival time of 42.9 gives a mean survival time after accrual of an $LD_{50/60}$ of 28.8 days. This is somewhat in excess of the expected mean survival time with exposure at a high dose rate. Thus, although the pattern of lethality with exposure at about 4 R/hr bears some analogy to that seen in acute-dose-rate exposure, survival times at about 2 R/hr present a different pattern.

In our continuous-exposure study at 3.79 R/hr, we took weekly blood samples of all animals beginning on day 9. In our terminated-exposure study at

0.84 R/hr, we took weekly samples during exposure from the highest dose group beginning on day 6. These data are summarized in Figs. 4 to 7, together with weekly values beginning with the seventh day of exposure estimated from the graphs of Still et al.⁸ for their continuous 1.96 R/hr study. In considering these data, we should remember that at 1.96 and 3.79 R/hr animals were dying during the period under examination but at 0.84 R/hr there were no deaths during exposure (the two animals of this group which ultimately died survived 22 and 39 days after the last blood sample taken during exposure).

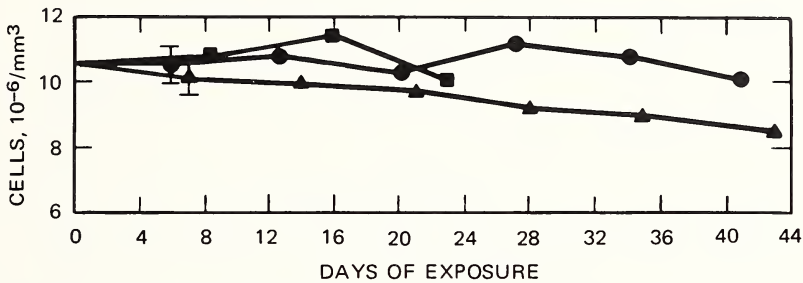

Fig. 4 Values for circulating erythrocytes in sheep during protracted exposure to ⁶⁰Co gamma radiation. Values for 1.96 R/hr are estimated from the data of Still et al. ●, 0.84 R/hr; ▲, 1.96 R/hr; ■, 3.79 R/hr.

The erythrocyte data for the three studies are shown in Fig. 4. For all three dose rates, there was little appreciable change in red cell count during the first three weeks of exposure. At 3.79 R/hr there was a slight decrease at the fourth week, when half the animals had already died. At 1.96 R/hr this decrease continued during the next three weeks. The red cell count was slightly depressed during the last week of exposure at 0.84 R/hr. Apparently at 3.79 R/hr lethality occurs before the peripheral red cell count responds to depressed erythroid activity in the bone marrow, whereas at 0.84 R/hr the injury accrual rate is too slow to be reflected in the peripheral circulation during the 6 weeks of exposure (red cell counts in this group do show a decrease beginning in the third week after the termination of exposure). Exposure at 1.96 R/hr appears to result in the proper combination of an injury accrual rate high enough and a survival time long enough for depressed red cell counts to be observed.

Total peripheral leukocyte counts are summarized in Fig. 5. Here the pattern among the three studies shows a distinct dose-rate effect. At all three dose rates, there was a definite decrease in total leukocyte count by the first observation after the beginning of exposure, the magnitude of depression being directly related to the dose rate. This initial decrease was followed by a small additional depression at the second observation a week later in all three groups. At the two higher dose rates, there was a further depression in leukocyte count, terminal values being of the order of 13% of the preirradiation level. At 0.84 R/hr the

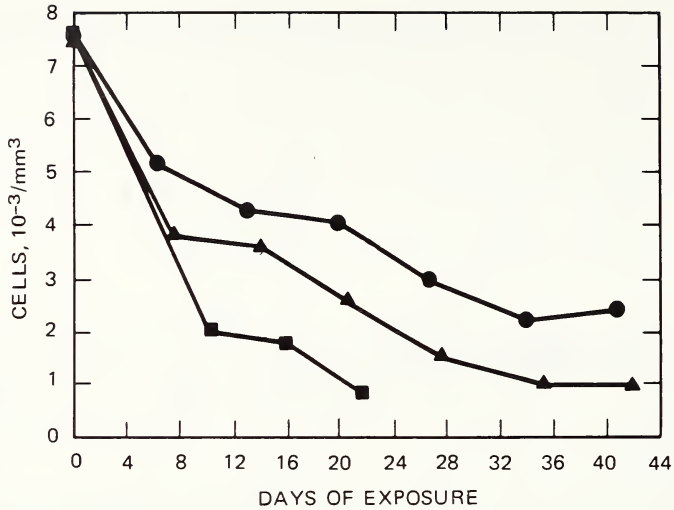

Fig. 5 Values for circulating total leukocytes in sheep during protracted exposure to ^{60}Co gamma radiation. Values for 1.96 R/hr are estimated from the data of Still et al. ●, 0.84 R/hr; ▲, 1.96 R/hr; ■, 3.79 R/hr.

second depression in total leukocytes occurred later, and the final values during exposure were about twice those observed at 1.96 and 3.79 R/hr.

Obviously, changes in total leukocyte counts represent the summation of changes in the myeloid and lymphoid leukocytes. In our work we differentiate the leukocytes only on the basis of whether they are granulocytic or mononuclear cells. For sheep about 85% of granulocytic cells are neutrophils, and 90% of mononuclear cells are lymphocytes. When we examine the changes in these two categories of leukocytes, we find that the dose-rate dependency described for total leukocytes is still there but that there are differences for the two cell categories.

The values for mononuclear leukocytes are summarized in Fig. 6. At either 3.79 or 1.96 R/hr, there was a sharp decline in cell count by about the end of the first week of exposure. This initial depression was complete at 3.79 R/hr, in the sense that the level reached was about 15% of the preirradiation level, but at 1.96 R/hr values about 15% of preirradiation levels were reached after about 3 weeks of exposure. At 0.84 R/hr, values during exposure never declined below about 25% of the preirradiation level, and this range of values was reached after about 3 weeks of exposure. With respect to mononuclear leukocytes, then, there appears to be a fairly discrete dose-rate dependency with respect to the extent of depression and the time of minimum values.

It has been noted before that changes in circulating lymphocytes following whole-body irradiation initially reflect primarily the high radiosensitivity (and consequent death) of circulating lymphocytes and then reflect the decreased

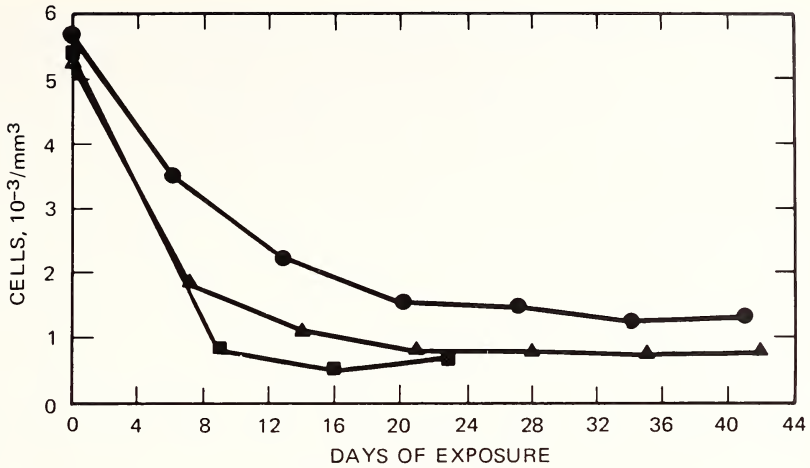

Fig. 6 Values for circulating mononuclear leukocytes in sheep during protracted exposure to ⁶⁰Co gamma radiation. Values for 1.96 R/hr are estimated from the data of Still et al. ●, 0.84 R/hr; ▲, 1.96 R/hr; ■, 3.79 R/hr.

output of the radiosensitive stem cell system of the bone marrow. Although originally derived for acute irradiation in small animals, this rationale appears to describe satisfactorily the changes in mononuclear leukocytes of the sheep discussed here.

The data for granulocytes are shown in Fig. 7. At 3.79 R/hr there was about a 50% depression by the end of the first week of exposure, no further decrease during the next week, and then a final depression to near-zero values during the next week in the animals surviving long enough to be assayed. At each of the two lower dose rates there was a slight depression in granulocytic cell count after about a week of exposure, then a slight rise during the next week. At 0.84 R/hr this "rebound" persisted for another week. After the apparent abortive rise,

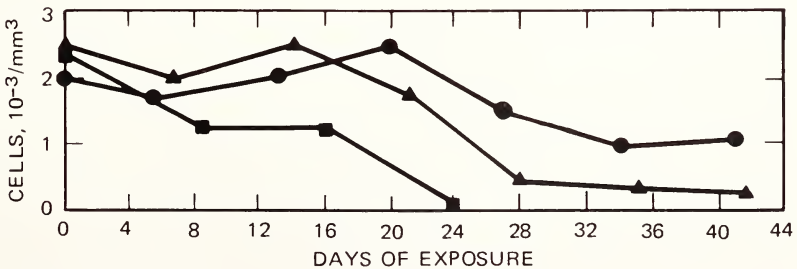

Fig. 7 Values for circulating granulocytes in sheep during protracted exposure to ⁶⁰Co gamma radiation. Values for 1.96 R/hr are estimated from the data of Still et al. ●, 0.84 R/hr; ▲, 1.96 R/hr; ■, 3.79 R/hr.

granulocytic cell count decreased over the next 2 weeks at both of the lower dose rates. At 1.96 R/hr, values less than 20% of preirradiation levels were observed during the final 3 weeks of observation. At 0.84 R/hr the maximum depression was only to about 50% of the preirradiation value.

In addition to higher radioresistance of circulating granulocytes, as compared with lymphocytes, there is also a considerable reserve of neutrophils available for release into the circulation. For example, Page et al.⁹ recently reported that in unirradiated sheep circulating granulocytic cells increase over 300% within a day of injection of endotoxin. As noted by Still et al.,⁸ these two factors could account for the chronologic delay in the decrease in circulating granulocytic cells of the sheep during continuous irradiation at doses of 1.96 or 0.84 R/hr. Still et al.⁸ also noted that the major point to be made from studies of continuous chronic exposure of large animals was that, unlike the rat, large animals appear unable to adapt to low-level whole-body gamma irradiation. This conclusion obviously appears valid at dose rates of 1.96 R/hr and up. As for lower dose rates, although there was no discernible change in the granulocytic cell count during the last 2 weeks of exposure at 0.84 R/hr (Fig. 7), further decreases have been observed during postexposure observation of these animals (now in progress). This finding, together with the fact that some deaths did occur after exposure, indicate that, although the sheep may be capable of some transient adaptation during protracted exposure, injury does accrue even at a dose rate below 1 R/hr.

REFERENCES

1. D. G. Brown, R. G. Cragle, and T. R. Noonan (Eds.), Proceedings of a Symposium and Dose Rate in Mammalian Radiation Biology, Apr. 29–May 1, 1968, Oak Ridge, Tenn., USAEC Report CONF-680410, UT–AEC Agricultural Research Laboratory, July 12, 1968.
2. G. E. Hanks, N. P. Page, E. J. Ainsworth, G. F. Leong, C. K. Menkes, and E. L. Alpen, Acute Mortality and Recovery Studies in Sheep Irradiated with Cobalt-60 Gamma Rays or 1 MVP X-Rays, *Radiat. Res.*, **27**: 397–405 (1966).
3. J. F. Taylor, E. J. Ainsworth, N. P. Page, and G. F. Leong, Influence of Exposure Aspect on Radiation Lethality in Sheep, Report NRDL-TR-69-15, Naval Radiological Defense Laboratory, Mar. 24, 1969.
4. E. T. Still, J. F. Taylor, G. F. Leong, and E. J. Ainsworth, Mortality of Sheep Subjected to Acute and Subsequent Protracted Irradiation, Report NRDL-TR-69-32, Naval Radiological Defense Laboratory, June 9, 1969.
5. E. T. Still, J. F. Taylor, G. F. Leong, and E. J. Ainsworth, The Influence of the Amount of Initial Radiation Exposure on the Recovery Pattern in Sheep, Report NRDL-TR-69-97, Naval Radiological Defense Laboratory, July 15, 1969.
6. T. S. Mobley, E. T. Still, W. Rush, J. F. Taylor, R. L. Persing, and T. C. DeFeo, Interlaboratory Comparison of Mortality in Sheep Exposed to ⁶⁰Cobalt Radiation, Report AFWL-TR-69-48, Air Force Weapons Laboratory, Air Force Systems Command, Kirtland Air Force Base, October 1969.
7. N. P. Page, E. J. Ainsworth, and G. F. Leong, The Relationship of Exposure Rate and Exposure Time to Radiation Injury in Sheep, *Radiat. Res.*, **33**: 94–106 (1968).

8. E. T. Still, J. F. Taylor, G. F. Leong, and E. J. Ainsworth, Survival Time and Hematological Responses in Sheep Subjected to Continuous ^{60}Co Gamma Irradiation, Report NRDL-TR-69-28, Naval Radiological Defense Laboratory, May 9, 1969.
9. N. P. Page, E. J. Ainsworth, and J. F. Taylor, Residual Injury of the Hematopoietic System of X-irradiated Sheep, NRDL-TR Report, Naval Radiological Defense Laboratory, July 15, 1969.

CRITERIA FOR RADIATION INJURY

JOHN S. KREBS

Stanford Research Institute, Menlo Park, California

ABSTRACT

The nature of radiation injury in animals is considered largely from the viewpoint of destruction of radiation-sensitive cells and tissues. The methods for determining the 37% survival dose (D_{37}) in animals is reviewed; the limitations of treating cell survival after irradiation as an exponential process are considered briefly; and some of the principal results on survival of animal cells are summarized. The relation of bone-marrow-cell survival to survival or death of the whole animal is considered. In two experimental comparisons the LD_{50} of the animal was predictable from the survival of the bone-marrow cells; in two other experimental comparisons there was no relation between stem-cell survival and LD_{50} . The rate of replacement of the bone-marrow cells after irradiation is considered briefly. Data collected from three independent sources gave a mean cell doubling time of 1.33 days (range, 0.96 to 1.7) for replacement of bone-marrow cells of rats and mice. There was no significant delay in initiation of recovery and no evident relation between cell doubling time and radiation dose.

The title "Criteria for Radiation Injury" suggests to me a large body of ideas, knotty problems, frustrations, and past confusions. From this somewhat amorphous mass of thought, there emerges a small group of propositions that I think can be called the principal driving forces of the problem of radiation injury.

First, the study of radiation injury actually implies the study of quantity of injury, methods for measuring injury, and identification of exposure conditions that may modify the kind or degree of injury. I note that this subject tends to come up before the nature or definition of radiation injury is even established. This leads to the second proposition: When we are primarily concerned with measurement of injury, the injury is defined strictly in terms of the experiment and the biological end point used to measure it. The third proposition is that adequate study of radiation injury requires the study of repair of injury if an adequate understanding of the biological meaning of injury is to be obtained.

In general, three types of biological end points have been used in the study of radiation injury: first, a change in some kind of physiological function or performance capacity; second, a loss or destruction of radiation-sensitive cells or tissues; and, third, a total-failure type of response, such as death or incapacitation. General biological theory holds that these three end points are mutually related by causal chains from the primary radiation events, but in practice the interrelations are often hard to draw without considerable unsupported speculation. In this review I have concentrated primarily on the second type of biological end point and will consider radiation injury and repair largely in terms of loss and replacement of tissue, with some remarks on the relation between tissue loss and biological failure, i.e., death.

RADIATION INJURY AS A DESTRUCTION OF SENSITIVE CELLS AND TISSUES

The modern study of radiation injury as a destruction of sensitive cells and tissues began about 10 years ago with the development of methods for *in vivo* measurement of the relative number of stem cells of bone marrow. These are cells that are capable of (1) self-replication and (2) differentiation into intermediate and final stages of formed elements of blood. Our present concept is that much of the significant radiation damage to bone marrow involves destruction of the stem cells and a consequent loss of the source of formed elements of blood.

The two methods for measuring stem cells in bone marrow are the colony-forming unit (CFU) of Till and McCulloch¹ and the erythropoietin-response technique of Gurney, Lajtha, and Oliver.² The first technique involves injecting a counted number of mouse bone-marrow cells into a lethally irradiated recipient mouse and counting the number of hemopoietic colonies that have developed in the spleen of the recipient mouse 8 to 10 days later. The second technique involves infusing an animal with erythrocytes until the hematocrit rises and erythrocyte production in the bone marrow ceases. The stem cells can then be stimulated by injection of erythropoietin to produce more erythrocytes, and the response can be measured by studying incorporation of ⁵⁹Fe into circulating erythrocytes. In both types of study the effect of radiation is expressed as a survival fraction (S/S_0), i.e., the fraction of the response of unirradiated animals in relation to radiation dose.

The result of a study of erythropoietic-stem-cell response in mice exposed to 250-kVp X rays is illustrated in Fig. 1. Here the fraction of surviving erythroid stem cells is plotted on a logarithmic scale against radiation dose, and an apparent straight line is obtained. For reasons of mathematical convenience, this line is characterized by two parameters: the apparent survival at zero dose, called the extrapolation number, and the 37% survival dose, called the D_{37} .

Each of the points in Fig. 1 represents the survival fraction of a group of five mice at the indicated dose, and the whole figure is the pooled result of 10 or 12

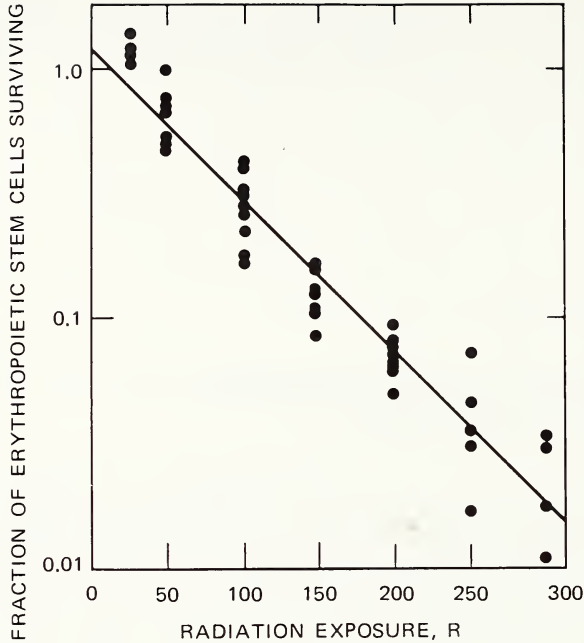

Fig. 1 Survival of erythropoietic-stem-cell response in mice as a function of dose of 250-kVp X rays.

experiments. Three comments can be made: First, the set of experiments as a whole can be fairly represented by a straight line on semilogarithmic paper, with an extrapolation number of 1.2 and a $D_{3.7}$ of 71.5 R. Second, the deviations of the points from the line are quite large, amounting at some of the doses to as much as 50 R of radiation exposure. Third, at the 25-R dose all the points show an increased survival above control values, as if the radiation had a stimulating effect on erythroid-stem-cell proliferation. The overall conclusion is that the effect of radiation on erythroid stem cells is a complex process in which destruction of the cells at an exponential rate is the principal result readily apparent over a sufficient range of doses but in which a number of other events also occur.

Similar results can be obtained by using the CFU technique mentioned previously. In addition, methods have been developed to study the radiation response of germinal cells of skin³ and intestinal⁴ epithelium. In these latter experiments it has not been possible to determine an extrapolation number, but values of $D_{3.7}$ have been obtained. All methods involving *in vivo* measurement of stem or germinal cells are subject to numerous untested assumptions, but they all seem to give exponential survival curves over a reasonable dose range.

This type of study of injury is not necessarily confined to cells. Figure 2 illustrates the relation between weight of the testes of mice and radiation dose at

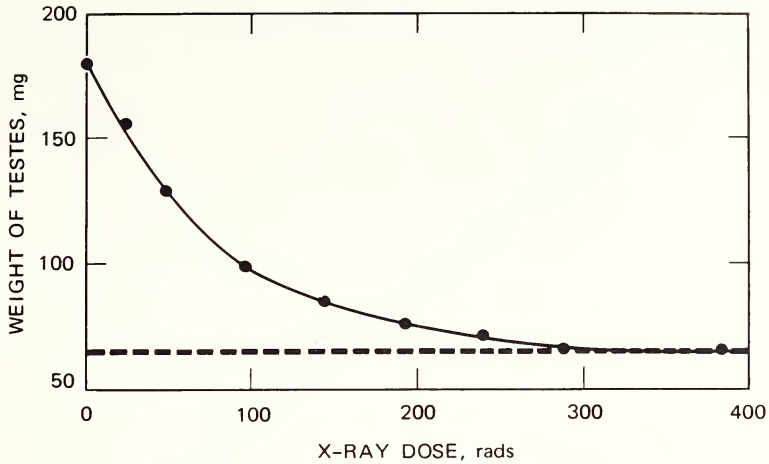

Fig. 2 Weight of testes of mice at 28 days after exposure to 250-kVp X rays as a function of radiation dose.

28 days after exposure to 250-kVp X rays. It can be seen that the testes' weight falls to a minimum value as the dose increases; this minimum value can be taken to be the weight of the nonsensitive structural portion of the tissue. When this nonsensitive weight is subtracted from the whole-testes weight at each dose and the fraction of radiosensitive weight remaining is plotted on a logarithmic scale against radiation dose, again a reasonably straight line is obtained, as shown in Fig. 3. The line shown has an extrapolation number of 1.0 and a D_{37} of 78.9 rads. It can be inferred that the involution of the testes following irradiation reflects the loss of stem cells (type A spermatogonia) from the testes.

A similar study has been done using loss of weight of the spleen in mice after irradiation. In this study there was also an exponential decrease in the survival of the radiosensitive portion of the spleen with increasing radiation dose. Similar studies can also be done with weight of mouse thymus or with DNA content of mouse bone marrow or spleen. In fact, I suspect that with some patience and imagination the radiosensitivity of a number of proliferative tissues in several animal species could be investigated.

Table 1 contains a brief list of values of D_{37} obtained for several cell lines and tissues exposed to X rays. The list is in no sense complete and is intended to indicate the level of radiosensitivity that may be expected from acutely proliferating cells and tissues of mammals. All measurements but the last were made *in vivo* with the techniques mentioned before. The last item, human liver cells, measured by using a cell-culture technique *in vitro*, is included to indicate that the radiosensitivity of human (and presumably other large mammal) cells is not grossly different from that of rats and mice.

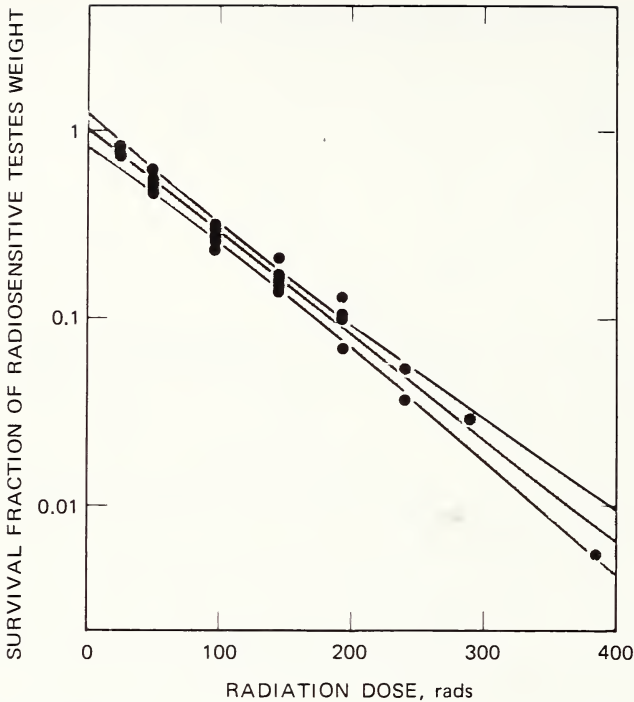

Fig. 3 Survival of the radiosensitive portion of mouse testes weight as a function of dose of 250-kVp X rays.

The values of D_{37} shown in Table 1 range from 54 to 160 R; most of the values fall between 70 and 120 R. At the present time this table seems to be a fair summary of the radiosensitivity of actively proliferating normal cells and tissues of animals. Radiation injury in the sense of destruction of radiation-sensitive cells and tissues, then, involves an exponential survival of the sensitive cells and tissues, with 37% of the tissue remaining for each increment of 70 to 120 rads.

RELATION BETWEEN CELL DESTRUCTION AND ANIMAL SURVIVAL

Given that we have some prediction of the sensitivity of cells to radiation, the question of greater interest is whether functional loss, incapacitation, or death of the animal can be related to the destruction of the cells. The data on this question are still somewhat limited, but a few direct comparisons are available for animal lethality.

The most direct comparison we can make is that between the 30-day LD_{50} in mice and the survival of stem cells of the bone marrow at the LD_{50} dose. The

Table 1
 D_{37} FOR VARIOUS CELLS AND TISSUES EXPOSED
 TO X RAYS

Cell or tissue	Animal	D_{37}	Reference
Erythropoietic stem cell	Mouse	65 rads	10
Erythropoietic stem cell	Mouse	110 rads	2
Erythropoietic stem cell	Mouse	71 R	11
Bone-marrow CFU	Mouse	77 R	5
Spleen CFU	Mouse	54 R	5
Erythropoietic stem cell	Dog	66 R	12
Testes weight	Mouse	79 R	13
Testes weight	Mouse	102 R	14
Testes weight	Rat	160 R	14
Testes weight	Hamster	160 R	14
Spleen weight	Mouse	140 R	11
Germinal layer of skin	Mouse	135 rads	3
Intestinal epithelium	Mouse	97 rads	4
Liver cells (tissue culture)	Human	119 rads	15

test system is one in which the LD_{50} can be altered in some way, e.g., by protection or by changing the dose rate or the type of radiation. The stem-cell-survival curve and the LD_{50} are determined for two conditions in which the LD_{50} values will be different, and the survival fraction of stem cells at the LD_{50} is calculated for each condition. If the survival fraction of stem cells is the same at both values of LD_{50} , this constitutes support for the hypothesis that death of an animal is caused by the reduction of the bone-marrow stem cells below some critical number.

A set of analyses of this type is shown in Table 2. The first part of the table summarizes the work of Ainsworth and Larsen⁵ on the relation of bone-marrow colony-forming units and LD_{50} in normal mice and in mice protected with AET (2-aminoethylisothiuronium bromide hydrobromide). The AET increased the LD_{50} by 80%, but the survival fraction of colony-forming units in bone marrow at the AET LD_{50} was nearly the same as at the untreated LD_{50} . The predicted LD_{50} is the dose at which the survival of CFU's in mice protected with AET was exactly the same as the survival of CFU's in unprotected mice at their LD_{50} . The predicted and measured LD_{50} 's are quite close together, and the results imply that lethality in the mouse is determined in this case by survival of CFU's.

Table 2
LD₅₀ VS. SURVIVAL OF BONE-MARROW STEM
CELLS

Colony-Forming Units in Mice Treated with AET		
	Control	AET treated
LD ₅₀	721 R	1313 R
Stem cell D ₃₇	77 R	128 R
S/S ₀ at LD ₅₀	1.5×10^{-4}	0.84×10^{-4}
Predicted LD ₅₀		1240 R

Erythropoietic Stem Cells in Mice Irradiated with X Rays or Neutrons		
	250-kVp X rays	Fission neutrons
LD ₅₀	880 R	384 rads
Stem cell D ₃₇	71.5 R	27.8 rads
S/S ₀ at LD ₅₀	5.46×10^{-6}	1.84×10^{-6}
Predicted LD ₅₀		354 rads

Colony-Forming Units in Mice Irradiated at Different Dose Rates		
	⁶⁰ Co (1700 R/hr)	⁶⁰ Co (200 R/hr)
LD ₅₀	896 R	1408 R
Stem cell D ₃₇	96.3 R	116.1 R
S/S ₀ at LD ₅₀	1.31×10^{-4}	7.32×10^{-6}
Predicted LD ₅₀		1073 R

The second part of the table shows a similar type of comparison for erythropoietic stem cells in mice irradiated with 250-kVp X rays or with fission neutrons. The results are from my own data, partly unpublished. The difference in LD₅₀ was more than a factor of 2, but again the survival fractions of stem cells at the respective LD₅₀'s were reasonably close. The predicted LD₅₀ differed from the measured LD₅₀ by only 30 rads, and these results confirm those of Ainsworth and Larsen. The third part of the table shows still another comparison of colony-forming units in mice irradiated with ⁶⁰Co at two different dose rates (these are unpublished results of D. C. L. Jones and myself). Decreasing the dose rate from 1700 R/hr to 200 R/hr increased the LD₅₀ by more than 50%. In this case, however, there was a substantial difference in the survival fraction of the colony-forming cells at the LD₅₀'s for the two dose rates, and the survival of the cells in this case appears to be a poor predictor of

Table 3

COMPARISON OF ENDOGENOUS COLONY-FORMING UNITS AND
LD₅₀ FOR MICE WITH GENETIC DIFFERENCES IN LD₅₀

Mouse strain	LD ₅₀ ,	D ₃₇ of CFU, R	Dose for 1	
	R		CFU/mouse, R	CFU/100 mice at the LD ₅₀
BALB/cJ	616	79.4	475	16.9
SWR/J	646	57.1	683	191.0
C57BL/6J	705	65.0	638	35.7
CBA/J	725	76.1	616	23.8
C57BR/cdJ	777	83.8	720	50.6

the LD₅₀. We still consider these results provisional, but the third result implies that factors other than stem-cell survival may exercise substantial control over death of the animal.

Results of a related study by Yuhas and Storer⁶ using inbred strains of mice with genetically determined differences in LD₅₀ and comparing the LD₅₀ with the dose and response relation for endogenous colony-forming units in the strains of mice are shown in Table 3; the original data have been converted to a form easily comparable with the previous results in Table 2. The second column of Table 3 lists the X-ray LD₅₀'s of the various strains of mice, and the last column shows a calculation of the number of colonies per 100 spleens expected at the LD₅₀ for the various strains. This calculation is equivalent to the calculation of survival fraction of stem cells at the LD₅₀ in the other studies. It can be seen that there is no relation in these strains of mice between the LD₅₀ and the survival of stem cells at the LD₅₀. This is in agreement with the studies on dose rate and in contrast to the studies on AET protection and neutron-X-ray irradiation.

The conclusion, then, is that survival of bone-marrow stem cells is an important but not an exclusive determiner of the lethal radiation dose to the animal and that other factors not yet determined also have a significant effect on lethal dose. The evidence that stem-cell survival does not constitute the sole determinant of animal lethality has important implications for the development of methods of treating lethal radiation injury.

REPAIR OF RADIATION INJURY: REPLACEMENT OF DESTROYED TISSUE

The ability of an animal to repair radiation injury implies eventually a replacement of the destroyed stem cells and tissues by accelerated proliferation of cells or reduced utilization and destruction of cells, or both. Because of the

nature of cell division, we tend to expect that the cell or tissue replacement will follow an exponential course of the form

$$\log X = kt \quad (1)$$

where X is the quantity of cells or tissue at time t and k is a growth-rate constant representing the net fractional gain of cells or tissue per unit time. The constant k can be determined by plotting $\log X$ against t , and a more convenient form of representation of k is $0.301/k$, which is the doubling time of the cells.

Figure 4 shows values for surviving percentage of colony-forming units in the mouse plotted on a logarithmic scale against time after exposure to 450 R of X rays. The data, which are taken from the work of Hanks and Ainsworth,⁷ have been fitted by a line of the form of Eq. 1 for the points between 1 and 11 days after irradiation. It can be seen that the data are reasonably fitted by the calculated line, considering the inherent variation of the data. The doubling time obtained for the fitted line was 1.33 days, or 31.9 hr. This doubling time is about twice the minimum generation time expected for cells of the bone marrow and probably represents a balance between the generation time for the colony-forming cells and the loss of colony-forming cells by differentiation to

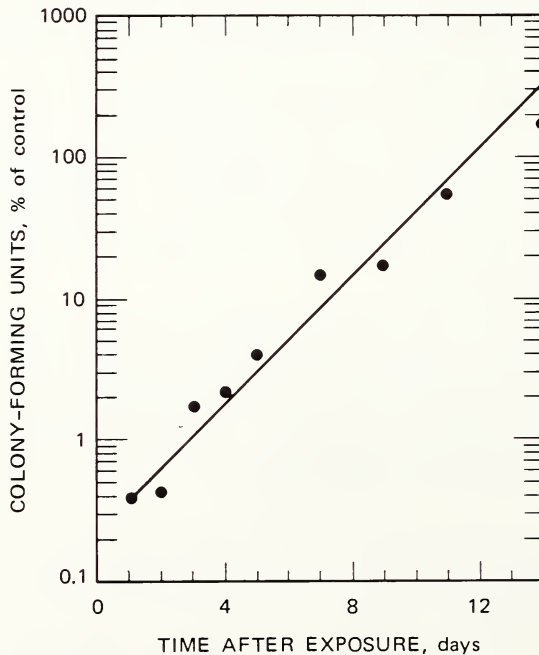

Fig. 4 Return of colony-forming units in the bone marrow of the mouse with time after exposure to 450 R of X rays.

more specialized types. Inspection of the fitted line indicates that cell replacement begins effectively at about 1/2 day after irradiation and recovery to 100% of the initial value is accomplished in 11.7 days.

The process of cell doubling does not continue indefinitely. As the value of X approaches the normal size or amount of tissue present in the unirradiated animal, the rate of growth slows and eventually stops at some steady state. In this region of repair the events are quite complex. Sometimes the number of cells exceeds the control value, as indicated in Fig. 4 at 14 days; sometimes the cell count settles at a value less than the control value; and sometimes the cell count goes through several oscillations above and below the control value. In general, the events in the region near 100% repair of tissue destroyed by radiation are not amenable to systematic analysis.

Some analysis can be done by using the empirical time point at which the radiation-damaged tissue comes to the level of 50% of the control value. For this purpose I have used the data on replacement of erythropoietic stem cells of the rat from Baum, Wyant, and Vagher⁸ and the data on total bone-marrow DNA (which is a measure of cell count) from Davis and Cole.⁹ The data are summarized in Table 4. The initial survival percentage was obtained from the data in the case of Baum et al. and was estimated by assuming a D_{37} of 80 rads in the case of Davis and Cole. The number of cell doublings to return the initial survival value to 50% of control was calculated from the initial survival, and the time to return to 50% of control was obtained from the data. The ratio of these values is the cell doubling time, shown in the last column in the table. The values for cell doubling time ranged from 0.96 to 1.72 days, and the mean doubling time was 1.33 days, precisely the value obtained from the data of Hanks and Ainsworth.⁷

Table 4
TIMES FOR REPAIR OF RADIATION-DESTROYED BONE
MARROW TO 50% OF CONTROL VALUE

Tissue measurement	Dose, R	S/S ₀	Number of cell doublings	Observed repair time, days	Calculated cell-doubling time, days
Erythropoietic stem cells	150	0.356	0.49	0.8	1.64
	200	0.166	1.59	1.95	1.23
	250	0.074	2.76	3.0	1.09
Bone-marrow total DNA	270	0.034	3.88	3.72	0.96
	390	0.0076	6.04	7.74	1.28
	485	0.00236	7.73	13.3	1.72
	540	0.00118	8.73	12.13	1.39

It appears, then, that rats and mice are able to rapidly replace bone-marrow cells destroyed by irradiation. The doubling time for replacement of such cells is about 32 hr, and the rate does not appear to depend on radiation dose. Considering the variety of sources of the data and the initial purposes of the experiments, the agreement is rather surprising. A number of obvious speculations could be made about the nature of cell replacement in other species, the possibility of modifying the replacement rate by drugs or other treatment, and the role of cell-replacement rate in determining the survival of the animal. These speculations are properly the source of ideas for future experimental investigation.

REFERENCES

1. E. A. McCulloch and J. E. Till, The Radiation Sensitivity of Normal Mouse Bone Marrow Cells, Determined by Quantitative Marrow Transplantation into Irradiated Mice, *Radiat. Res.*, **13**: 115-125 (1960).
2. C. W. Gurney, L. G. Lajtha, and R. Oliver, A Method for Investigation of Stem-Cell Kinetics, *Brit. J. Haematol.*, **8**: 461-466 (1962).
3. H. R. Withers, The Dose-Survival Relationship for Irradiation of Epithelial Cells of Mouse Skin, *Brit. J. Radiol.*, **40**: 187-194 (1967).
4. H. R. Withers and M. M. Elkind, Radiosensitivity and Fractionation Response of Crypt Cells of Mouse Jejunum, *Radiat. Res.*, **38**: 598-613 (1969).
5. E. J. Ainsworth and R. M. Larsen, Colony-Forming Units and Survival of Irradiated Mice Treated with AET or Endotoxin, *Radiat. Res.*, **40**: 149-176 (1969).
6. J. M. Yuhas and J. B. Storer, On Mouse Strain Differences in Radiation Resistance: Hematopoietic Death and the Endogenous Colony-Forming Unit, *Radiat. Res.*, **39**: 608-622 (1969).
7. G. E. Hanks and E. J. Ainsworth, Repopulation of Colony-Forming Units in Mice, *Nature*, **215**: 20-22 (1967).
8. S. J. Baum, D. E. Wyant, and J. P. Vagher, Comparative Hematopoietic Cytokinetics in Rats Exposed to Either 250 kvp X Ray or Mixed Gamma-Neutron Radiation, Report AFRR1-SR-68-2, Armed Forces Radiobiology Research Institute, January 1968.
9. W. E. Davis, Jr., and L. J. Cole, Comparative Effects of Fast Neutrons and X-Rays on Marrow Deoxyribonucleic Acid (DNA) Content in Mice, *Radiat. Res.*, **14**: 104-116 (1961).
10. R. Alexanian, D. D. Porteous, and L. G. Lajtha, Stem-Cell Kinetics After Irradiation, *Int. J. Radiat. Biol.*, **7**: 87-94 (1963).
11. J. S. Krebs, Stanford Research Institute, unpublished data.
12. R. J. Holloway, M. L. Albright, G. F. Leong, J. S. Krebs, and E. L. Alpen, Stem Cell Migration and Radiosensitivity in the Bone Marrow of the Dog, Report NRDL-TR-69-98, Naval Radiological Defense Laboratory, July 1969.
13. J. S. Krebs, Analysis of the Radiation-Induced Loss of Testes Weight in Terms of Stem Cell Survival, Report NRDL-TR-68-104, Naval Radiological Defense Laboratory, September 1968.
14. H. I. Kohn and R. F. Kallman, Testes Weight Loss as a Quantitative Measure of X-Ray Injury in the Mouse, Hamster, and Rat, *Brit. J. Radiol.*, **27**: 586-591 (1954).
15. D. L. Dewey, Effect of Oxygen and Nitric Oxide on the Radiosensitivity of Human Cells in Tissue Culture, *Nature*, **186**: 780-782 (1960).

SPECIES RECOVERY FROM RADIATION INJURY

J. F. SPALDING and L. M. HOLLAND

Biomedical Research Group, Los Alamos Scientific Laboratory, University of California,
Los Alamos, New Mexico

ABSTRACT

The acute dose of gamma radiation required to produce death of livestock may range from as little as 300 to as much as 800 rads. All mammalian species have a recovery capability or an increased tolerance, or both, to protracted radiation which is not necessarily related to the acute lethal dose for the species. Recovery from single acute or protracted nonlethal exposures may be expected within 90 to 120 days in most mammalian species, leaving no irreparable somatic lesion of consequence to livestock. Transient or permanent sterility may be caused in some mammalian species by nonlethal doses of radiation. However, hereditary radiation-induced genetic injury following nonlethal exposures to ionizing radiation should not be of serious concern to livestock breeders.

In the event of nuclear war, all life on earth would be exposed to increased levels (above normal background) of ionizing radiation and might suffer some degree of radiation injury. Living organisms in or near high-priority target areas would be subjected to more-intense exposure and thus would die or would suffer from delayed radiation effects from serious but nonlethal exposures. It is perhaps ironical, but nonetheless true, that the most technically and culturally advanced societies would suffer the greatest impact of a nuclear war, for, in effect, the creation would attempt to paralyze and destroy its creators. The degree to which a target society can survive a nuclear weapon attack is directly related to its knowledge and understanding of the effects and limitations of ionizing radiation. This presentation, as its title suggests, concerns some aspects of recovery in mammals exposed externally to serious but nonlethal levels of ionizing radiations. Because livestock are the mammals of interest at this symposium, emphasis is on natural recovery from radiation injury without therapy.

LETHAL AND NONLETHAL EXPOSURES

Since this discussion is concerned primarily with mammalian recovery from radiation injury, lethality is only briefly considered. Figure 1 clearly illustrates that the doses required to kill 50% of the animals within 30 days of exposure ($LD_{50/30}$) differ markedly among species. It is also apparent that wide intraspecies $LD_{50/30}$ ranges have been reported by different investigators.¹⁻³

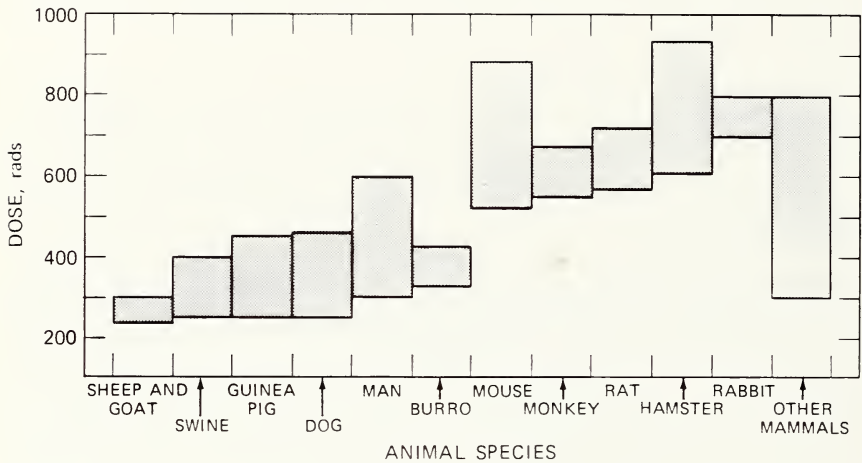

Fig. 1 Approximate $LD_{50/30}$ dose range reported for different mammalian species showing intraspecies and interspecies variation.

From $LD_{50/30}$ data presently available, one might assume that farm animals in general have a relatively low $LD_{50/30}$ from whole-body short-term (acute) exposures of between 300 and 800 rads. Although the species difference in $LD_{50/30}$ is real and highly significant, no species characteristics such as life-span, body weight, and metabolic rate have been shown to relate well to the $LD_{50/30}$ value. It can only be said that survival or death after large acute doses of ionizing radiation in a given species is influenced to varying degrees by such factors as sex, age, physical fitness, environment, and exposure conditions. The ability to tolerate and recover successfully from radiation injury is not unique to (or denied to) any one mammalian species. Given the proper recovery environment and temporal conditions, all mammalian species have a recovery capability.

CAUSE AND TIME OF DEATH

Cause of death from whole-body irradiation is generally considered to be a function of the total exposure received (dose) and the time span over which the

dose was received (dose rate). This relation is illustrated in Fig. 2. Although the figure does not show the time span over which the dose was received, a survival-time curve for increasing dose rate, which is academic and for illustration only, is shown which may or may not represent the actual survival time of any single species. Note, however, that serious gastrointestinal or cerebral (central nervous system) injury is quite unlikely to be successfully repaired. Thus it becomes apparent that discussion of species recovery from radiation injury is, for the most part, a discussion of the repair characteristics of hematopoietic organs.

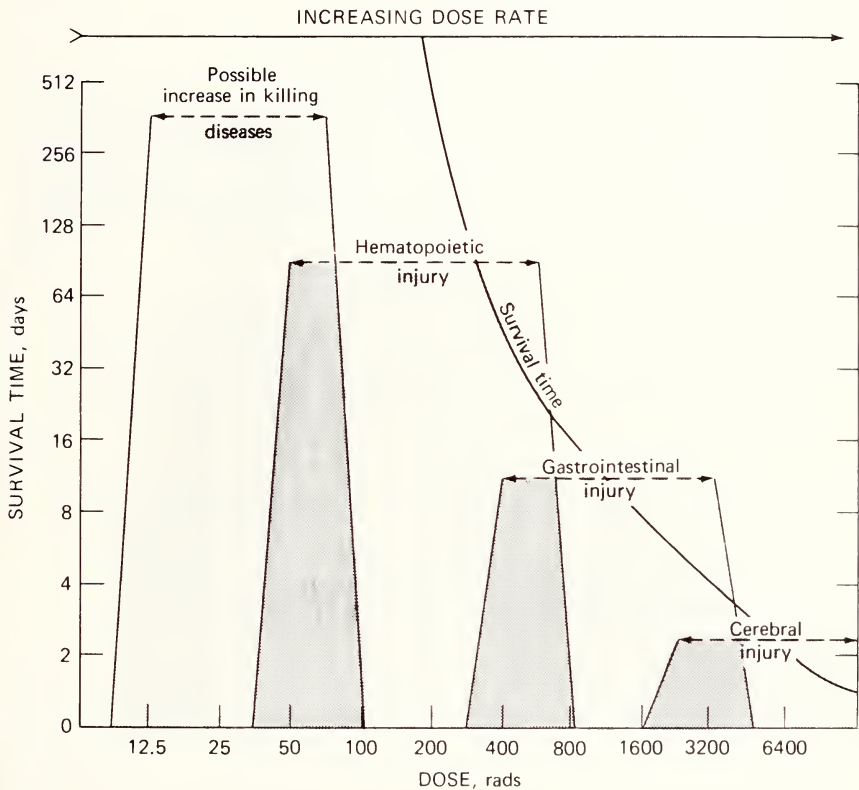

Fig. 2 Generalized relation of cause and time of death, dose rate, and total-dose whole-body exposure.

Perhaps the most significant factor involved in species recovery from exposure to ionizing radiation is dose rate. The relation between dose rate and mean lethal dose or recovery capability as the dose rate progresses from protracted or chronic to acute for an animal with an $LD_{50/30}$ of about 450 rads is shown in Fig. 3. Although the degree of this dose-rate effect varies from one

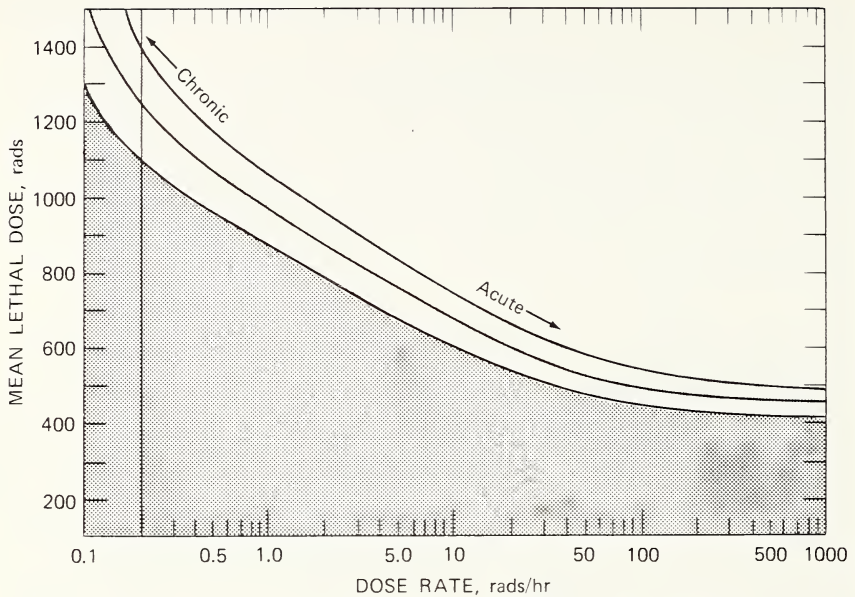

Fig. 3 Graphic relation between dose rate and mean lethal dose for a mammal with an acute $LD_{50/30}$ of 450 rads. The acute lethal-dose $LD_{50/30}$ is shown on the right. As the dose rate changes from acute to chronic effects (right to left), the mean lethal dose can be expected to increase.

species to another, the general dose-rate-effect relation should apply to all mammals.

RATE OF REPAIR AND GENETIC INVOLVEMENT OF HEMATOPOIETIC RECOVERY

Although experience suggests that no mammalian species has been denied the capability of repairing radiation injury, there is ample evidence that this capability varies widely among species. Variations of repair in mammals have been reviewed by Page,³ who rated several species according to their response or recovery capability from protracted radiation exposures. Mice and swine are rated as having the most efficient recovery capability, and, as in the case of the $LD_{50/30}$, there appears to be no easily recognized correlation between repair efficiency and phenotypic or genotypic species characteristics.

Recovery rate of hematopoietic tissue has been shown to be independent of size of acute conditioning dose in mice⁴ and independent of total accumulated dose from continuous exposures.⁵ Mice exposed to ^{60}Co gamma rays at a dose rate of 4.5 rads/hr for 188 and 355 hr showed similar lag times (approximately 10 to 12 days) from termination of the gamma-ray stress to the maximum

depression in red blood cell count (RBC). Recovery from the point of maximum depression to the 50% level was also similar (approximately 7 to 9 days) for the two groups in spite of a dose-difference factor of 1.89.

These observations are shown graphically in Fig. 4. Independence of the repair rate of size of protracted gamma-ray dose has also been observed in monkeys. Peripheral blood characteristics of monkeys exposed to 500, 750, or

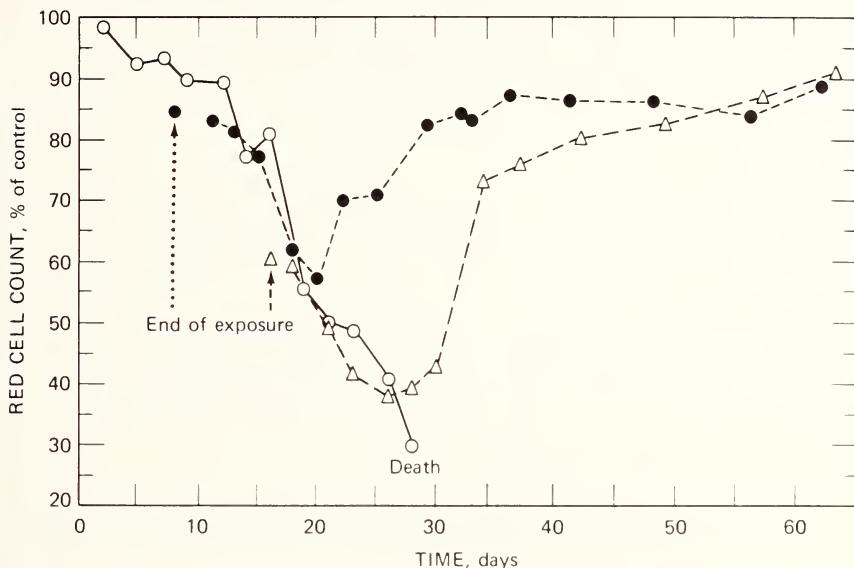

Fig. 4 Red blood cell (RBC) repopulation in peripheral blood following protracted gamma-ray exposure of the mouse. Exposure for all groups was started on day 1. The exposure was continued to death for group 1 and was terminated after 188 hr for group 2 and after 355 hr for group 3. Delayed response and recovery are shown for groups 2 and 3 following gamma-ray exposure. \circ , group 1; \bullet , group 2; \triangle , group 3.

1000 rads of gamma rays during a 10-day period are shown in Figs. 5 and 6. Animals receiving 500 rads showed only slightly depressed RBC characteristics; however, those exposed to 750 and 1000 rads showed dose-related injury but dose-independent recovery (Fig. 5). The lymphocyte response, plotted in Fig. 6, also shows dose-dependent response or injury and recovery rates independent of dose.

Response to radiation injury from protraction of ionizing radiation dose varies widely among mammalian species. The degree to which a species responds to injury from ionizing radiation is, no doubt, genetically inherent to the given species. This genetic influence on radiation resistance may be expressed as resistance to or repair of radiation injury. Recent investigations with mice suggest that different responses to radiation injury within the same mouse strain

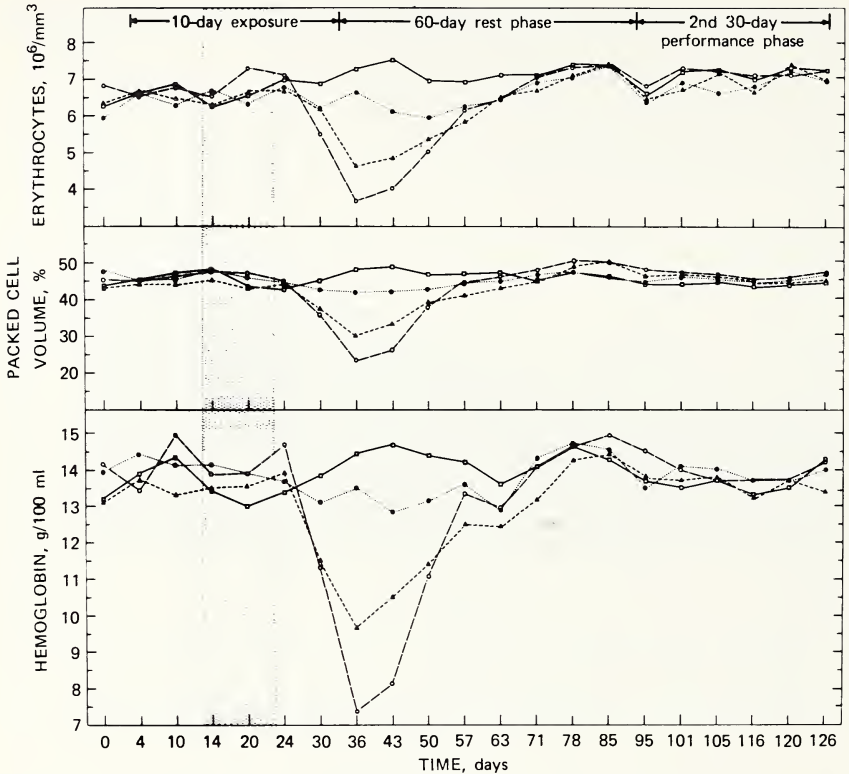

Fig. 5 Radiation-induced depression and recovery of hemoglobin, packed cell volume, and red-blood-cell count in the peripheral blood of monkeys following 0 (\square), 500 (\bullet), 750 (\blacktriangle), and 1000 (\circ) rads of gamma rays protracted over 10 days of exposure.

may be due to a resistance factor rather than to inherent differences in the rate of repair from radiation-induced injury. In Fig. 7 the packed cell volume (PCV) from peripheral blood samples of two mouse substrains is plotted during and after 21 days of gamma-ray exposure at a dose rate of 4.1 rads/hr. The difference in radiation response between the two substrains, as shown in the figure, can be attributed to differences in resistance to radiation (either dose rate or total dose) rather than to hematopoietic recovery (repair-rate) differences between the two substrains. If the $LD_{50/30}$ method had been used on day 32 (11 days after exposure, Fig. 7) to determine the repair rate, one might have erroneously attributed the substrain difference in response to radiation to highly significant differences in repair rate of hematopoietic tissue. This problem may exist to some degree in recovery rates reported for different mammalian species where the degree of injury in the repair half-time test is assumed to be

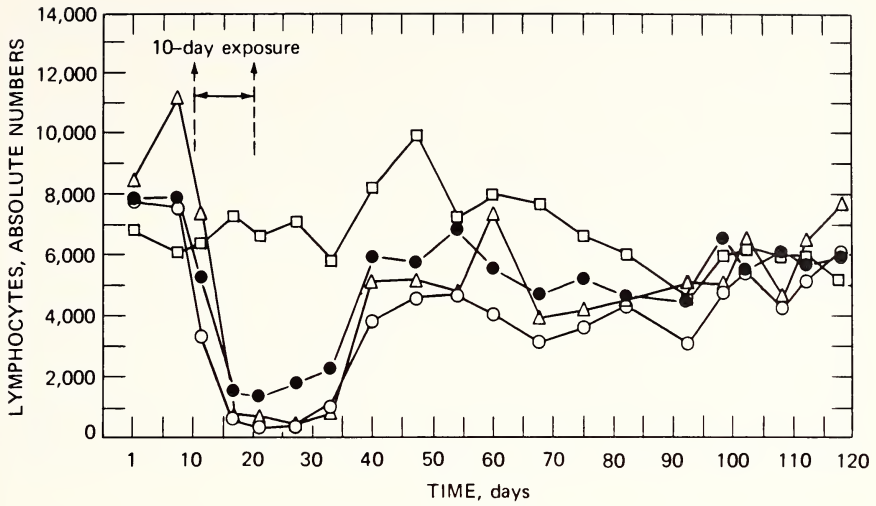

Fig. 6 Radiation-induced depression and recovery of lymphocytes in the peripheral blood of monkeys following 0 (□), 500 (●), 750 (△), and 1000 (○) rads of gamma rays protracted over 10 days of exposure. Values are the averages of surviving animals per group.

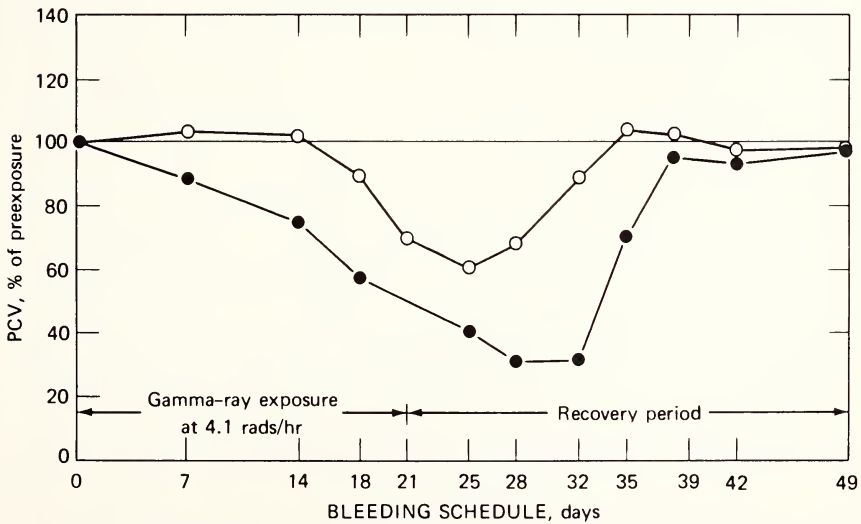

Fig. 7 Radiation-induced depression and recovery of packed cell volume in the peripheral blood, during and following gamma-ray bone-marrow block, of two substrains of mice with different radiation-resistance characteristics. ○, resistant strain; ●, nonresistant strain.

completely dose dependent but is otherwise unknown. The radiation-resistance factor given in Fig. 7 has been shown to be genetic⁶ and to be consistent with a single-gene-locus hypothesis.⁷

BONE-MARROW RESILIENCE AND "IRREPARABLE INJURY"

As stated earlier, in successful recovery from radiation injury, the bone marrow (hematopoietic tissue) is the organ of primary concern. Thus a knowledge of bone-marrow resilience from continuous or repeated radiation stress, or both, in the mammal is elementary to an understanding of the "irreparable" component of radiation injury and repair kinetics. Protracted or fractionated exposures, or both, are required to produce this kind of information. Investigations using protracted and fractionated exposures showed mouse bone marrow to be extremely resilient to injury from ionizing

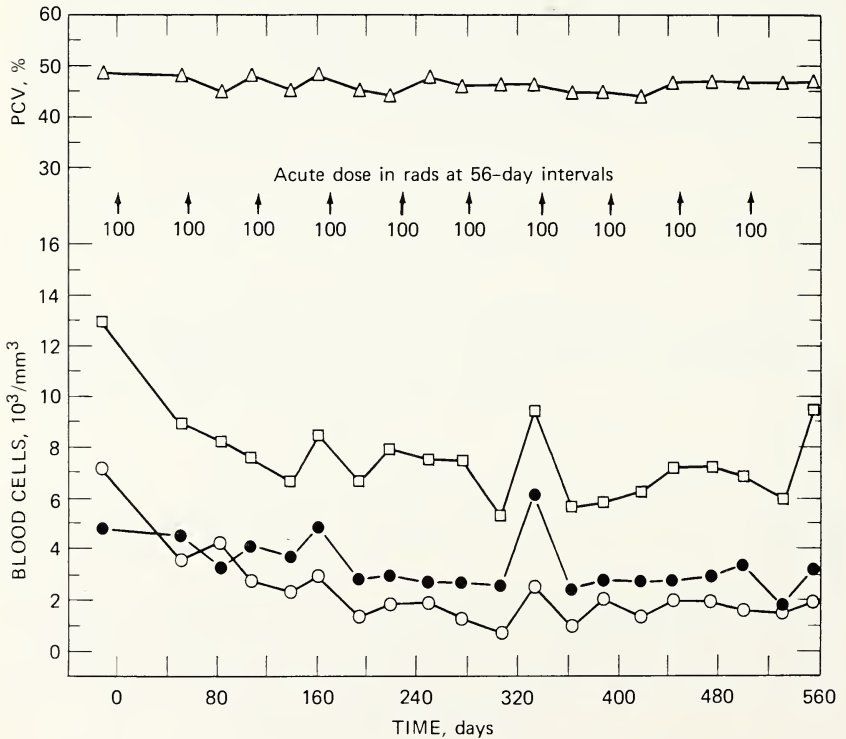

Fig. 8 Peripheral blood characteristics of monkeys 27 and 51 days after 10 100-rad gamma-ray exposures at 56-day intervals. Monkeys in this group were given no gamma-ray-insult exposure before the fractionated exposures. Δ , packed cell volume; \square , white blood counts; \bullet , lymphocytes; \circ , neutrophils.

radiation.^{8,9} Irreparable injury was observed using the method of reduced $LD_{50/30}$ from radiation insult doses after allowing 90 days for repair.⁸ The resilience of bone marrow and irreparable injury in the mouse have been well documented. Monkeys are being investigated to make similar determinations on larger mammals.

Four groups of monkeys were given challenge or insult gamma-ray exposures of 0 (control), 500, 750, or 1000 rads protracted over 10 days. They were then allowed 14 months to recover from injury inflicted by the insult doses. After the recovery period all groups were placed on a gamma-ray-exposure regime that subjected them to a 100-rad exposure (at 35 rads/hr) every 56 days. Bone-marrow resilience and irreparable injury were examined periodically in terms of peripheral blood analysis. Figures 8 to 11 are graphs of packed cell volumes and white blood cell values at 27 and 51 days after each exposure during the first 560 days of this gamma-ray-exposure regime. These figures illustrate quite clearly the resilience, or recovery capability, of hematopoietic

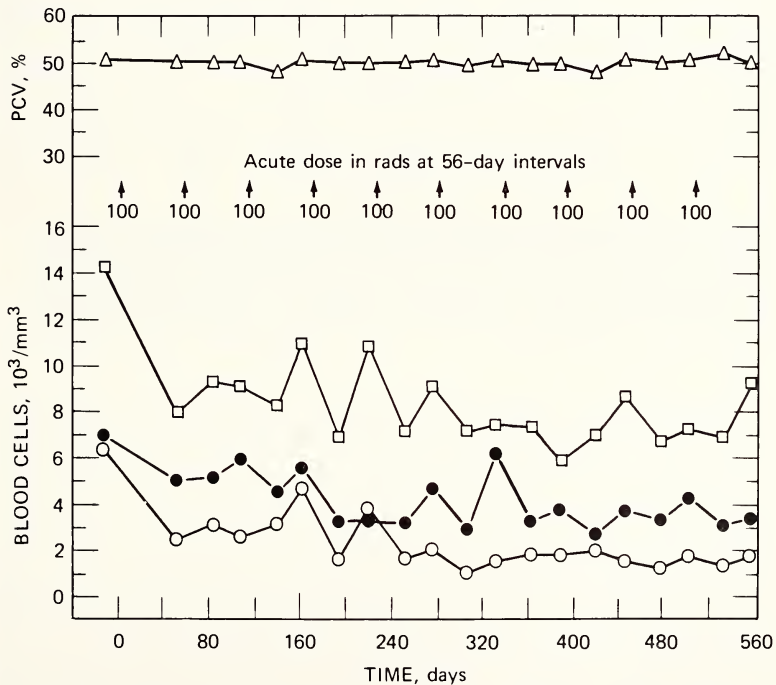

Fig. 9 Peripheral blood characteristics of monkeys 27 and 51 days after 10 100-rad gamma-ray exposures at 56-day intervals. Monkeys in this group were given an initial 500-rad gamma-ray-insult exposure 14 months before the fractionated exposures. Δ , packed cell volume; \square , white blood counts; \bullet , lymphocytes; \circ neutrophils.

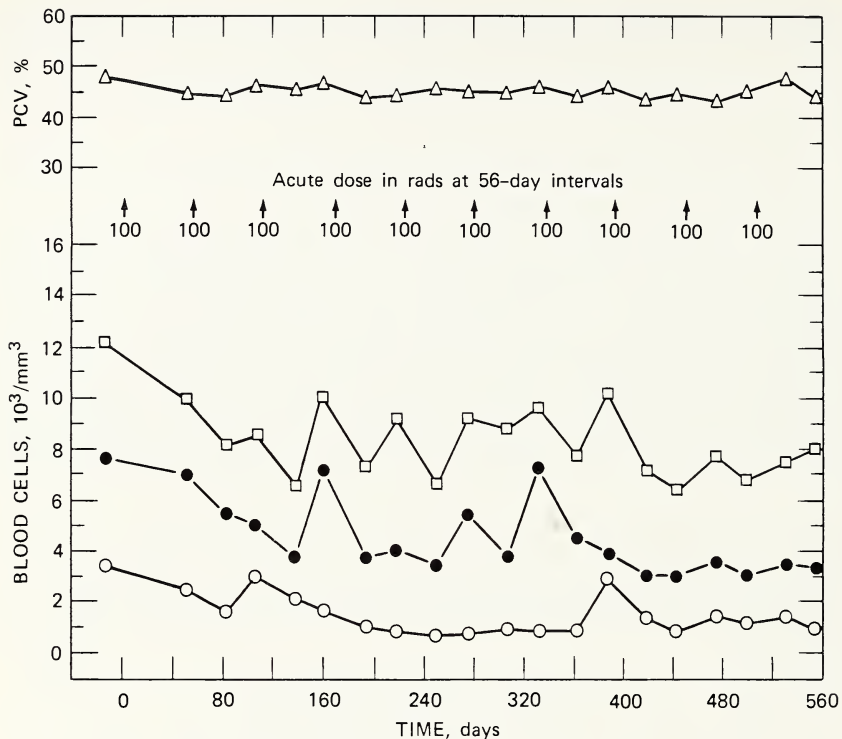

Fig. 10 Peripheral blood characteristics of monkeys 27 and 51 days after 10 100-rad gamma-ray exposures at 56-day intervals. Monkeys in this group were given an initial 750-rad gamma-ray-insult exposure 14 months before the fractionated exposures. Δ , packed cell volume; \square , white blood counts; \bullet , lymphocytes; \circ , neutrophils.

tissue in the monkey. It can also be seen from Figs. 8 and 11 that, if an irreparable lesion was caused by the 1000-rad insult dose in the third group (Fig. 11) or in the other two groups subjected to insult doses (Figs. 9 and 10), it is not expressed as a decrement in hematopoietic repair observable in peripheral blood. The resilience of the *Macaca mulatta* bone marrow to this radiation regime is of particular interest because earlier investigations with *Macaca arctoides*,¹⁰ using the fractionation method of exposure but in a more stressful regime, showed the monkey to have poor recovery characteristics.

Almost since the discovery of the injurious effects of ionizing radiation, attempts have been made to equate biological injury and recovery to mathematical models. Hollister, Vincent, and Cable¹¹ pointed to some of the frustrations of predicting early radiation lethality over a wide range of exposure conditions; however, under a given set of exposure conditions, predictions of lethality and irreparable injury have been quite accurate.¹² Thus it seems

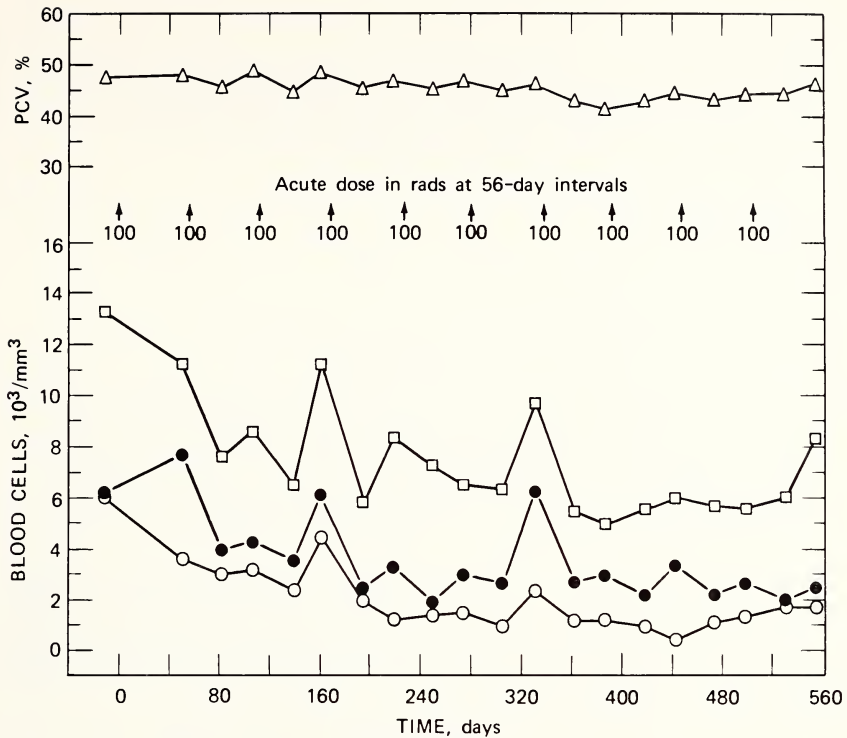

Fig. 11 Peripheral blood characteristics of monkeys 27 and 51 days after 10 100-rad gamma-ray exposures at 56-day intervals. Monkeys in this group were given an initial 1000-rad gamma-ray-insult exposure 14 months before the fractionated exposures. Δ , packed cell volume; \square , white blood counts; \bullet , lymphocytes; \circ , neutrophils.

inappropriate not to try to predict by use of a simple mathematical model the demise of the monkeys involved in this investigation. If we assume that the mean repair half-time (RT_{50}) for all body organs, tissues, and related physiological functions essential to the sustenance of life is 28 days, that 10% of the exposure-dose-related injury is irreversible, and that, when the dose-equivalent injury to the whole body reaches 450 rads, 50% lethality can be expected, we can make the survival-prediction graph shown in Fig. 12. As shown in the figure, the four groups of monkeys in this investigation would theoretically have irreparable radiation lesions, which would be expected from acute gamma-ray exposures of 0, 50, 75, or 100 rads, or 10% of the insult doses they received 14 months before the fractionated-gamma-ray-exposure regime. Thus the four groups would have effective acute body burdens of 100, 150, 175, or 200 rads (Fig. 12) immediately following the first 100-rad gamma-ray fraction. Additional 100-rad gamma-ray fractions at 56-day intervals would add reparable and

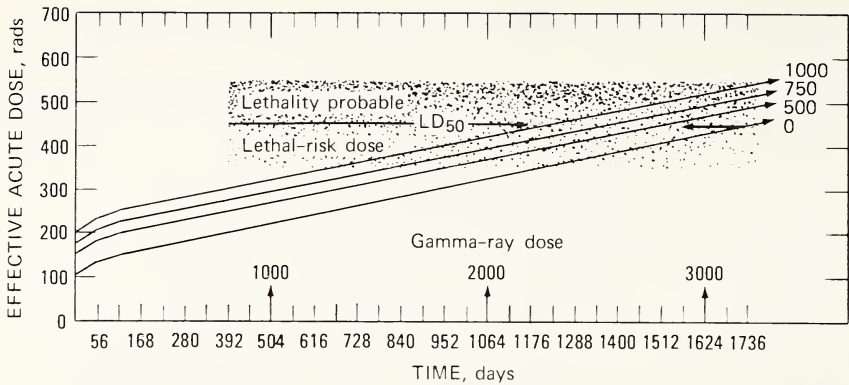

Fig. 12 Graph of an effective-acute-dose (EAD) model to predict the accumulation of lethal-dose levels of fractionated gamma rays in monkeys with 0-, 500-, 750-, and 1000-rad insult doses 14 months before receiving 10 100-rad gamma-ray exposures at 56-day intervals. RT_{50} is assumed to be 28 days, and the irreparable component is assumed to be 10%.

irreparable injury as shown by the line plots for each group, and a lethal body burden could be expected following 14 100-rad fractions for the group with a 1000-rad insult dose and following 22 100-rad exposures in the control group. Figures 8 to 11 show that, after 10 100-rad gamma-ray fractions, peripheral blood elements in all groups are at physiologically safe levels and hematopoietic tissue does not appear degenerate.

Whether or not animals on this radiation-exposure regime will obligingly adjust their physiological state to conform with this model (Fig. 12) cannot now be said. One thing is evident, however: Even the monkey, previously rated low in terms of recovery capability, has a remarkable tolerance to radiation injury when exposure and repair conditions are optimum.

INJURY, RESILIENCE, AND CONTINUITY OF GENETIC MATERIAL

A discussion of species recovery from radiation injury would be wanting without a few words on the possible genetic effects of exposure to ionizing radiations. It is commonly known that developing mammalian germ cells are among the most radiosensitive cells. Popular genetic theory also propounds that the sensitivity of germ cells to the lethal effects of ionizing radiation extends to a mutagenic sensitivity that can accumulate significantly and can result in severe genetic decrements to future generations. The statement that there is increasing evidence of biological effects of small exposures, particularly from a genetic standpoint is frequently heard or read. This theory has been perpetuated by notable scientific media and by such popular journals as *Esquire*.

Several long-term investigations have been carried out in this and other countries to determine the possible genetic hazards of ionizing radiation. In one investigation each of 55 generations of male mouse progenitors received acute whole-body gamma-ray exposures of 200 rads. A similar experiment in man, with a generation time of 30 years, would require 1650 years; thus, for reliable data on man, it would have been necessary to start at about the time of the Roman Empire. A few comparative characteristics of control and irradiated lines of mice which are of possible interest to livestock breeders are shown in Fig. 13.

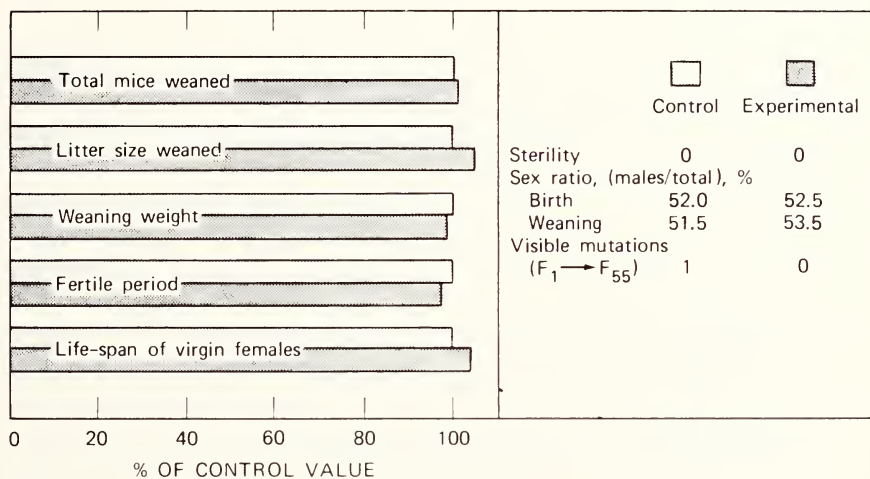

Fig. 13 Comparative breeding and litter characteristics in control mice and mice with up to 55 generations of X-irradiated male progenitors (100 breeding pairs per group).

Experimental animals from 45 generations of irradiated male progenitors had a shorter fertile life but weaned larger litters (with slightly smaller weaning weights) and produced more total offspring (with longer life spans) than did control mice. However, none of these characteristics was significantly different from control values. After 55 generations, no sterility was observed in either line. Sex ratio at birth and weaning did not differ greatly. Only one viable mutation was observed—a spontaneous mutation for hairlessness in the control line.

Although this investigation was carried out with intensive inbreeding (which in theory is an undesirable scheme to accumulate genetic injury), other investigations using different breeding methods have produced similar negative findings. Experimental evidence is contrary to the popular theory of radiation-induced genetic decrement mentioned previously. Not only is there *no* increased experimental scientific evidence of genetic effects from small exposures but also

experimental results of long-term radiation genetics programs are so disgustingly negative that little or no interest can be generated to support such programs.

ACKNOWLEDGMENT

This work was performed under the auspices of the U. S. Atomic Energy Commission.

REFERENCES

1. V. P. Bond, T. M. Fliedner, and J. O. Archambeau, *Mammalian Radiation Lethality, A Disturbance in Cellular Kinetics*, Academic Press, Inc., New York, 1965.
2. G. W. Casarett, Patterns of Recovery from Large Single-Dose Exposure to Radiation, in *Comparative Cellular and Species Radiosensitivity*, pp. 42–52, Igaku Shoin, Ltd., Tokyo, 1969.
3. N. P. Page, The Effect of Dose-Protraction on Radiation Lethality of Large Animals, in *The Proceedings of a Symposium on Dose Rate in Mammalian Radiation Biology*, D. G. Brown, R. G. Cragle, and T. R. Noonan (Eds.), Apr. 29–May 1, 1968, Oak Ridge, Tenn., USAEC Report CONF-680410, p. 12.1–23, UT–AEC Agricultural Research Laboratory, July 12, 1968.
4. J. F. Spalding, T. T. Trujillo, and W. L. LeSturgeon, Dependence of Rate of Recovery from Acute Gamma-Ray Exposure on Size of the Conditioning Dose, *Radiat. Res.*, **15**: 378–389 (1961).
5. J. F. Spalding and M. A. Van Dilla, Effect of Size of Dose from Protracted Gamma-Ray Exposure on Repair Rate of Hematopoietic Tissue, unpublished.
6. J. F. Spalding, D. M. Popp, and R. A. Popp, A Within-Strain Difference in Radiation Sensitivity in the RFM Mouse, *Radiat. Res.*, **40**: 37–45 (1969).
7. J. F. Spalding, D. M. Popp, and R. A. Popp, A Genetic Effect on Radiation Sensitivity Consistent with a Single Gene Locus Hypothesis, *Radiat. Res.*, **44**: 670–673 (1970).
8. J. F. Spalding, V. G. Strang, and F. C. V. Worman, Effect of Graded Acute Exposures of Gamma Rays or Fission Neutrons on Survival in Subsequent Protracted Gamma-Ray Exposures, *Radiat. Res.*, **13**: 415–423 (1960).
9. J. F. Spalding, Comparative Repopulation Recovery of Circulating Erythrocytes Following Graded Second Gamma-Ray Exposures in Mice, *Radiat. Res.*, **29**: 114–120 (1966).
10. J. F. Spalding, L. M. Holland, and O. S. Johnson, Kinetics of Injury and Repair in Monkeys and Dogs Exposed to γ -Ray Fractionation, *Health Phys.*, **17**: 11–17 (1969).
11. H. Hollister, A. R. Vincent, and J. W. Cable, A Prediction of Early Radiation Lethality Using an Effective Dose, USAEC Report CONF-813-1, from the 10th Annual and First International Meeting of the Western Section of the Operations Research Society of America, September 1964, Honolulu, Hawaii (TAB-R-4).
12. J. F. Spalding, T. T. Trujillo, and W. L. LeSturgeon, The Predictability of Irreparable Biological Damage from Exposure to Ionizing Radiation, *Radiat. Res.*, **15**: 754-760 (1961).

RADIOIODINE AIR UPTAKE IN DAIRY COWS AFTER A NUCLEAR-CRATERING EXPERIMENT

RONALD E. ENGEL,* STUART C. BLACK,† VICTOR W. RANDECKER,* and
DELBERT S. BARTH*

*Bureau of Air Pollution Sciences, Environmental Protection Agency, Research Triangle Park, North Carolina, and †Western Environmental Research Laboratory, Environmental Protection Agency, Las Vegas, Nevada

ABSTRACT

During a nuclear-cratering experiment, four lactating and three dry, pregnant dairy cows were exposed to the effluent cloud in an experiment designed to measure the transfer of radioiodine to milk, tissues, and excreta of the dairy cow when exposure was due primarily to inhalation during cloud passage.

The lactating cows were milked twice daily. The dry cows were sacrificed at three different times after the event. Radioiodine was measured in all milk samples and in 50 different biological samples from each of the sacrificed animals. The "inhalation" exposure as calculated from air-sampler data was not sufficient to account for the observed milk levels; this indicated that the majority of the exposure occurred by inadvertent ingestion. The term "air uptake" was used to take into consideration all routes of entry.

At 56 hr postevent the ^{131}I concentration was higher in the abomasal tissue than any other tissue except the thyroid and higher in abomasal contents than in the contents of the remainder of the gastrointestinal tract. The effective time in abomasal tissue and contents was also longer than in other samples, except in the thyroid. In maternal and fetal thyroids, the peak concentration occurred at 72 hr postexposure, when the thyroids contained 5.3 and 4.5%, respectively, of the estimated intake. However, the concentration in fetal thyroid was 2.4 times that of the maternal thyroid.

Nuclear devices detonated in the atmosphere or in cratering experiments produce calculable quantities of radioiodines. However, the concentrations of radioiodine observed in the biosphere under different conditions are extremely variable. The chemical and physical forms of radioiodines following nuclear fission reactions are of major importance. Less is known, quantitatively, about

inhalation of radioiodine from field sources than about any other aspect of radioactivity resulting from these reactions.¹

Radioiodines released into the atmosphere and available to the pulmonary system may be hazardous only under specific, pertinent conditions existing at the time of the release. Biological availability depends on such physical factors as the source of the radioiodines, the proximity of the source to the study, and meteorological conditions existing before and after release.

It is difficult to investigate every facet of radioiodine fallout in detail. However, adequate exposure and dosage determinations are required for establishment of accurate radiation-protection guides. To make these determinations with regard to inhalation of radioiodines, we must answer the following questions:²

1. What are the potential sources of atmospheric radioiodine contamination?
2. What are the chemical and physical properties of both gaseous and particulate forms of radioiodines, and what is the degree of fractionation?
3. What is the particle size distribution inhaled by the animal and the biological availability of each size?
4. What fraction of the intake of radioiodines is retained in the body following inhalation?
5. What are the lung deposition, retention, translocation, and elimination factors of inhaled radioiodines in normal physiological states?
6. What is the distribution of radioiodines in specific tissues and organs of various species of animals?

Nuclear-cratering experiments offer an excellent opportunity to study the distribution, deposition, and uptake of radioiodines in dairy cows following exposure to the radioactive cloud. This report, the scope of which is limited to question 6, deals with the concentrations of ^{131}I in tissues, milk, and excreta of dairy cows following exposure to a radioactive cloud produced by the 4.3 ± 0.4 -kt Project Palanquin nuclear-excavation experiment.

PROCEDURES

Experimental Design

Nineteen lactating and three nonlactating, pregnant Holstein cows were grouped for this experiment as shown in Table 1. Each animal used was free of obvious signs and symptoms of any infectious disease and had no physical defects. Assignments to the first four groups were based on a stratified random allocation. Lactating cows were first grouped by milk production, butterfat production, and days in production and were then randomly assigned to the experimental groups. The selection of Group V was based on milk production prior to the dry period.

Groups I, II, and III remained at the dairy barn throughout the entire study period. These three groups, which were fed contaminated forage from the three

Table 1
GROUPING OF DAIRY COWS

Group	Number of cows	Location	Type and duration of exposure*
I	6	Dairy barn	Average intake of 8.9 kg/day of contaminated green chop from Station 3 for 4 days
II	6	Dairy barn	Average intake of 7.1 kg/day of contaminated hay from Station 3 for 8 days
III	3	Dairy barn	Average intake of 7.1 kg/day of contaminated hay from Station 2 for 9 days and 9.4 kg/day from Station 1 for 12 days
IV	4	Station 3	Air uptake, exposed during and after cloud passage at Station 3 for 56 hr
V	3	Station 3	Air uptake, exposed during and after cloud passage at Station 3 for 56 hr

*The dairy barn was located approximately 70 km from ground zero. Station 1 was 4.7 km from ground zero at an azimuth of 350°; Station 2, 5.5 km from ground zero at an azimuth of 026°; and Station 3, 4.6 km from ground zero at an azimuth of 004°.

experimental stations, will not be discussed in this report. Groups IV and V, the subjects of this report, were maintained at Station 3 from April 6 to 16 and at the dairy barn thereafter.

Station 3 was located 4.60 km from the detonation point at an azimuth of 4°. The station was located on a terrain that had a slight slope and a moderate cover of natural vegetation. Facilities for Station 3 consisted of seven portable milking stanchions designed to hold dairy cows comfortably while facing the ground zero.³ Each cow was fitted with a blanket to reduce the exposure to cold, wind, and moisture. The stanchions were 0.6 meter apart to allow room for the milkers and also to reduce the physical contact between cows. Each stanchion had an automatic waterer and removable feed box. Time of milking was as close to the regular schedule as possible. Each cow in Group IV was milked with the same Surge milking bucket throughout the experiment and with the same equipment as normally used at the dairy barn.⁴ Milking techniques were identical to those used during normal routine milking. Samples of milk, grain, water, and hay were taken daily for background determination prior to the event. Temperature and respiratory rates were taken for all seven cows in the morning and evening. Blood samples for hematology and blood chemistry were taken before and after the exposure. Just before the event the feed boxes were

removed and the waterers turned off and covered to prevent any further ingestion. Because of radiological health procedures, Group IV cows were not milked until 31 hr after cloud passage. They were subsequently milked at 40 and 54 hr postevent. Uncontaminated hay and grain were carried in by the milking team. Water was provided only during the milking period. Samples of hay, milk, grain, and water were taken at the time of milking. Approximately 56 hr postevent all seven animals were returned to the dairy barn, were separated from Groups I, II, and III, and were maintained on uncontaminated hay, grain, and water.

Tissue Sampling

The Group V cows were sacrificed at intervals of 62, 76, and 125 hr after the detonation, and a complete and detailed necropsy was done on each animal. Milk samples were taken in cubitainers and counted by standard procedures.⁵ Various types of biological samples were taken for gamma-spectrum analysis. Samples were put in 400-ml cottage-cheese containers and counted by placing the container directly on top of a 10- by 10-cm NaI(Tl) crystal coupled to a Technical Measurement Corp. multichannel analyzer. The 200 channels used were calibrated at 10 keV per channel (0 to 2 MeV). The spectra were resolved by use of the matrix method. Whenever possible, repeat counts were done on all available tissues and contents. The minimum detectable activity was approximately 100 pCi in the sample for a 20-min counting time.

RESULTS AND DISCUSSION

Cow Group Comparisons

Groups of cows were compared for total serum protein (TP), thyroid binding index (TBI), and protein-bound iodine (PBI). The values were not significantly different among the groups except for a significantly higher PBI in Group V. The hematological values for the cows in the field (Groups IV and V) were not essentially different from those for cows in the dairy barn (Groups I, II, and III). The variation in milk production of Group IV during the experimental period did not differ from that of Groups I, II, and III. Temperature and respiratory rates of animals in Groups IV and V did not differ significantly while they were at the field station.

To develop the estimated intake of radioiodines for Groups IV and V, we must first assume that there was no physiological difference in any of the animals which would affect the metabolism of radioiodine. This assumption is justifiable for the following reasons:

1. On the basis of previous herd history, all groups of cows had equal stable iodine intakes throughout the study.

2. On the basis of TBI, TP, and milk and butterfat production in the prior lactation, Group V cows were not significantly different from the rest of the herd.

3. On the basis of TBI, TP, and temperature and respiratory rates taken during the experiment, Group V cows were not essentially different from those in other groups except in stage of lactation.

4. On the basis of the necropsy findings of Group V cows, all cows were assumed to be normal and were in good physical condition during the study period.

Air Concentration

Since instrumentation located at Station 3 indicated that the leading edge of the base surge reached the station approximately 12 min after detonation, this is the reference time for our calculations. The end time for the calculations is set at H + 56 hr, at which time the cows were removed from Station 3. Data from a Gelman Instrument Company Tempest air sampler located 30 meters in front of the cows were used to determine the integrated air dose for the 56-hr period. After the sampler had operated for 30 hr postdetonation, the prefilter and charcoal cartridge were changed, and it ran for an additional 24 hr before sampling was discontinued. It is reasonable to assume that an insignificant exposure occurred during the final 2 hr. The integrated air concentration of ^{131}I for the first 30 hr of exposure was $246 \mu\text{Ci-sec/m}^3$ (the prefilter was $190 \mu\text{Ci-sec/m}^3$ and charcoal cartridge was $56 \mu\text{Ci-sec/m}^3$), and for the next 24 hr it was $18 \mu\text{Ci-sec/m}^3$. The latter figure indicates that resuspension occurred, because the prefilter contained 99.7% of the total activity.

Exposure Determinations

The results for the cows exposed by "inhalation" are somewhat different from those expected for this type of exposure. The increased concentration in the second milking after exposure suggests a delayed absorption of radioiodine which is more characteristic of ingestion.⁶ This is complicated by the reduced milk production of these cows caused by the 31-hr delay between exposure and first milking. Cows could have ingested radioiodines by licking the stanchion parts or the ground, or the clean feed and water brought to them during the reentry period could have been inadvertently contaminated by resuspended material. Another indication that inhalation was not the sole source of exposure for these cows is the incongruous result obtained by assuming the maximum possible inhalation [assuming that (1) the cow breathes at the rate of 100 liters/min ($1.7 \times 10^{-3} \text{ m}^3/\text{sec}$) (Ref. 7), (2) deposition in the respiratory tract was 100%, and (3) the air sampler was 100% efficient]. The cows were exposed for 56 hr to integrated air concentrations of $246 \mu\text{Ci-sec/m}^3$ during the first 30 hr and $18 \mu\text{Ci-sec/m}^3$ for the next 24 hr. The deposition in the cow, with these assumptions, would have been:

$$(1.7 \times 10^{-3} \text{ m}^3/\text{sec})(246 \mu\text{Ci-sec/m}^3 + 18 \mu\text{Ci-sec/m}^3) = 0.45 \mu\text{Ci} \quad (1)$$

The average secretion in milk was 25.9 μCi , or about 57 times this calculated intake.

Since the actual inhalation intake of the seven cows exposed at Station 3 is unknown, and since exposure-dose relations are required for the tissue- and content-distribution study in the three sacrificed cows, the milk-secretion data were used to estimate intake. Because we know that the average secretion of Groups II and III (also fed hay and grain) was 10.6%, it is reasonable to estimate the total ^{131}I exposure by assuming that cows in Group IV also secreted 10.6% of their total radiiodine intake.⁸ Therefore the average milk secretion of the Group IV cows, 25.9 μCi , represents 10.6% of their estimated intake of 244 μCi of ^{131}I . This is reasonable since subsequent field experiments have shown that the dairy herd averaged 10.7% ^{131}I secretion in milk under similar feeding regimens using different contaminants.^{5,9-13} This average is similar to that found by most other investigators.^{2,14-19}

Thus, if our assumptions are correct, it is readily apparent that uptake of ^{131}I from inhalation contributed very little $[(0.45 \times 100)/(244 - 0.45) = 0.18\%]$ to the total dose. Therefore we use the term "air uptake," which takes into consideration inhalation as well as other routes of entry; e.g., skin absorption, licking of surroundings, licking of nasal secretions.

Milk Concentrations

A peak milk concentration of 1.6 $\mu\text{Ci/liter}$ for Group IV occurred at the second milking. The time of peak was similar to that in controlled studies using diatomaceous earth aerosols^{5,9,10,12} and in other studies using oral or intravenous doses of ^{131}I (Refs. 15, 16, and 20). The milk data indicate that some activity was taken in after the initial exposure. From 40 to 73 hr, the effective time (T_{eff}) was 33.1 ± 1.36 hr, and, from 73 to 154 hr, the T_{eff} was 16.3 ± 0.9 hr. For both time periods the T_{eff} was 18.1 ± 0.9 hr. For single-exposure studies the milk activity peaks at the first milking and then decreases, with a T_{eff} of less than 24 hr.

The foregoing results indicate that the ^{131}I -concentrating mechanisms of Group V cows were consistent with those in other studies and that the exposure was due to an initial dose followed by continued intake while the cows were at the field station.

Tissue Concentrations from Air Uptake

An average of 50 biological samples was removed from each of the Group V cows and analyzed specifically for ^{131}I . The rates of uptake, retention, and deposition derived from these data may be useful in developing mathematical prediction models and in analog computer simulation.

The data from a different cow at each point in time was used to determine the transfer rates between the various body compartments. Effective half-life values were determined by assuming that the cows' physiological states were equivalent for each point because no lesions of any significance were noted during postmortem examination. The half-life ($T_{1/2}$) was then determined by use of the linear-regression line drawn through the three points representing the three times of sacrifice. The concentration of ^{131}I in the biological samples at 56 hr postevent, the time the animals were removed from further exposure, are listed in Table 2. These were calculated by using the $T_{1/2}$ to correct for decay between removal from Station 3 and sacrifice.

Table 2
CONCENTRATION OF ^{131}I IN BIOLOGICAL SAMPLES

Biological sample	Total weight, g	Half-life, hr	^{131}I sample concentration,* $\mu\text{Ci/g}$	Retention, † ‡ %
Foregut tissue	14,600	34	205	1.22
Foregut contents	41,350	34	760	12.9
Abomasum tissue	2,700	44	662	0.74
Abomasum contents	900	49	680	0.63
Hindgut tissue	7,720	31	195	0.63
Hindgut contents	14,000	31	680	3.93
Maternal thyroid	37	230	345,000	5.26
Fetal thyroid	13		833,000	4.46
Liver	10,000	29	91	0.38
Respiratory tract	3,380	32	78	0.11
Kidney	1,605	44	115	0.07
Urine	309	20	880	0.11
All others:				
Blood, spleen, bone, muscle, skin	473,330	34	16	3.08
Total	570,000			33.6

* Activity was corrected to 56 hr postevent.

† Retention is based on an estimated 244- μCi exposure.

‡ Percentage = $\frac{\text{sample concentration} \times \text{total weight}}{244 \mu\text{Ci}} \times 100$.

Certain conclusions are evident based on the $T_{1/2}$ in the contents or tissues. There were no significant differences for $T_{1/2}$ in foregut (rumen, reticulum, and omasum), hindgut (duodenum, jejunum, ileum, and colon), respiratory tract, and other tissues (blood, spleen, bone, muscle, and skin). The average $T_{1/2}$ for these compartments, 31.5 ± 2.4 hr, is considered the same as the transport time of ^{131}I for nonthyroidal tissues. Lengemann²¹ observed two half-times for various compartments in the dairy cow, a short-lived portion of 17 and 22 hr for

blood and feces, respectively, and, later, 58 and 46 hr, respectively, over a 7-day period.

When rats that had inhaled Ag^{131}I were sacrificed near the time of thyroid peak, the gastrointestinal tract, liver, lung, kidney, and spleen were found to contain measurable amounts of radioactivity.^{2,2,2,3} This was considered a reflection of the iodine equilibrium beginning to establish itself in the plasma. By 50 hr the thyroid contained 60% of the body burden.

Bustad²⁴ listed the tissues containing ^{131}I following establishment of ^{131}I equilibrium in the blood of sheep. The thyroid, feces, mandibular salivary gland, milk, abomasal wall, and urine contained concentrations of ^{131}I higher than those found in the blood. Other tissues (listed in descending order) containing concentrations of ^{131}I lower than those in the blood were the parotid gland, liver, ovary, kidney, adrenal gland, pituitary gland, lungs, lacrimal gland, heart, pancreas, spleen, thymus, brain, and lens.

Our data clearly show that the $T_{1/2}$ of the abomasal tissue (44 hr) is longer than that of the other nonthyroidal tissues (32 hr) and shorter than that of the thyroid (9.6 days); the thyroid value has been reported to vary between 4.5 days for a single oral dose and 16 days for a single contaminating event.⁶ Assuming an uptake of 244 μCi of ^{131}I , 33.6% of the total estimated exposure was found in the tissues by the methods used in this study. The remainder of the ^{131}I is assumed to have been eliminated via feces and urine; this assumption is consistent with data reported by others^{1,5,17,21} and tends to confirm the calculated uptake.

The high percentage of iodine recovered from the intestinal contents indicates uptake by ingestion, but it may have been due partly to elimination of a large percentage of the deposited particulate matter from the lung via the "mucous-cilia escalator"; i.e., the material was coughed up, swallowed, and absorbed via the gastroenteric route. It has been suggested that the gastrointestinal tract can be an important route of entry of inhaled material into the systemic circulation.^{2,5} The $T_{1/2}$ of 9.6 days for the thyroid also indicates a continued uptake rather than a single-dose type of exposure.

Barua, Cragle, and Miller²⁶ reported that, by using a nonabsorbed marker-technique (^{144}Ce), they were able to determine the net absorption of orally administered radioiodine in young animals. The rumen appeared to be a major site of absorption, and the abomasum a major site of endogenous secretion. Net absorption occurred from the second section of the small intestine throughout the remainder of the tract. When sodium iodide was administered intravenously $1/2$ hour before slaughter, a significantly greater concentration of radioactivity was found in the abomasum than in the first part of the small intestine.

Our data tend to substantiate these findings. Our data indicate that, on an activity per weight basis, at 56 hr the foregut and hindgut tissue were approximately equal, each having about one-third the concentration of the abomasum. The concentration of ^{131}I in the contents of each was also similar,

about one-half that of the abomasum contents. It appeared that net absorption of iodine was taking place throughout the tract at the same rate as was the net loss, i.e., that secretion was equal to absorption. This suggests that, as shown by others,^{2,7} a constant physical relation, or equilibrium, exists in the lower tract for iodine.

The percent of calculated intake in the thyroid of the adult and the fetus was in close agreement with that found in the literature.^{2,8,29} Concentrations of ¹³¹I in the fetal thyroid during advanced gestation may be one to two times that in the adult thyroid of sows, two to three times that in the thyroid of ewes, and up to six times that in the thyroid of cows.²⁹ In this experiment the fetal thyroid concentration was 2.4 times that of the maternal cow.

Swanson, Lengemann, and Monroe³⁰ found a rapid concentration of ¹³¹I in the thyroid in the first two days with a slower increase to the peak uptake on the third day. The winter peak of 18.4% uptake was reached on the third day, but the summer peak of 18.0% was not reached until the fifth day. The estimated peak for our studies is at 72 hr, which is similar to the winter peak and at a concentration of 5.2% of the estimated dose. Garner et al.¹⁴ reported a peak uptake of 5% at 48 hr and an effective half-life of 4.5 days in dairy cows.

REFERENCES

1. H. D. Bruner, Symposium on the Biology of Radioiodine: Statement of the Problem, *Health Phys.*, **9**: 1083 (1963).
2. R. E. Engel, Potential Hazards as a Result of Inhalation of Radioiodines: A Literature Survey, USAEC Report TID-22693, Southwestern Radiological Health Laboratory, Jan. 5, 1966.
3. Southwestern Radiological Health Laboratory, Radioiodine Study in Conjunction with Project Sulky, USAEC Report SWRHL-29-r, May 27, 1966.
4. Southwestern Radiological Health Laboratory, ¹³¹I Dairy Cow Uptake Studies Using a Gaseous Aerosol, SWRHL, preliminary data, 1968.
5. D. S. Barth and M. S. Seal, Radioiodine Transport for a Synthetic Dry Aerosol Through the Ecosystem Air-Forage-Cow-Milk Using a Synthetic Dry Aerosol, in *Radioecological Concentration Processes: Proceedings of the International Symposium*, B. Aberg and F. P. Hungate (Eds.), Pergamon Press, Inc., New York, 1966.
6. L. K. Bustad, D. H. Wood, E. E. Elefson, H. A. Ragan, and R. O. McClellan, I-131 in Milk and Thyroid of Dairy Cattle Following a Single Contamination Event and Prolonged Daily Administration, *Health Phys.*, **9**: 1231 (1963).
7. National Academy of Sciences, *Handbook of Respiration*, W. B. Saunders Company, Philadelphia, 1958.
8. S. C. Black, R. E. Engel, V. W. Randecker, and D. S. Barth, Radioiodine Studies in Dairy Cows Following the Palanquin Event, USAEC Report PNE-914F, Southwestern Radiological Health Laboratory, 1971.
9. R. E. Stanley, S. C. Black, and D. S. Barth, ¹³¹I Dairy Cow Studies Using a Dry Aerosol, USAEC Report SWRHL-42-r, Southwestern Radiological Health Laboratory, August 1969.
10. Southwestern Radiological Health Laboratory, ¹³¹I Dairy Cow Uptake Studies Using a Submicron Synthetic Dry Aerosol (Project SIP), USAEC Report SWRHL-39-r, April 1971.

11. Southwestern Radiological Health Laboratory, ^{131}I Transport Through the Air—Forage—Cow—Milk System Using an Aerosol Mist (Project Rainout), Report SWRHL-43-r, 1967.
12. S. C. Black, D. S. Barth, R. E. Engel, and K. H. Falter, Radioiodine Studies Following the Transient Nuclear Test (TNT) of a KIWI Reactor, USAEC Report SWRHL-26-r, Southwestern Radiological Health Laboratory, May 1969.
13. W. Shimoda, S. C. Black, K. H. Falter, R. E. Engel, and D. S. Barth, Study of a Single Dose ^{131}I — ^{126}I Ratio in Dairy Cows, USAEC Report SWRHL-27-r, Southwestern Radiological Health Laboratory, April 1970.
14. R. J. Garner, B. F. Samson, and H. G. Jones, Fission Products and the Dairy Cow. III. Transfer of ^{131}I to Milk Following Single and Daily Dosing, *J. Agr. Sci.*, **55**: 283 (1960).
15. R. J. Garner and H. G. Jones, Fission Products and the Dairy Cow. IV. The Metabolism of ^{131}I Following Single and Multiple Doses, *J. Agr. Sci.*, **55**: 387 (1960).
16. R. F. Glascock, The Secretion of a Single Tracer Dose of Iodine (Labeled) in the Milk of the Lactating Cow, *J. Dairy Res.*, **21**: 316 (1954).
17. F. W. Lengemann and E. V. Swanson, A Study of the Secretion of Iodine in Milk of Dairy Cows Using Daily Oral Doses of ^{131}I , *J. Dairy Sci.*, **40**: 216 (1957).
18. L. B. Sasser and C. A. Hawley, Jr., Secretion of ^{131}I into Milk Under Conditions of Environmental Contamination of Pasture, *J. Dairy Sci.*, **49**: 1501 (1966).
19. H. M. Squire, L. J. Middleston, B. F. Samsom, and C. R. Coild, Experiments on the Metabolism of Certain Fission Products in Dairy Cows, in *Radioisotopes in Scientific Research*, Proceedings of the International Conference, Paris, September 1957, R. C. Extermann (Ed.), Vol. 4, Pergamon Press, Inc., New York, 1958.
20. K. Steenberg, Secretion of ^{131}I from a Dairy Cow After an Oral Administration of a Single Dose in Aqueous Solution, *Acta Agr. Scand.*, **9**: 198 (1959).
21. F. W. Lengemann, ^{131}I Concentrations in Blood, Milk, Urine, and Feces of Dairy Cows Following a Single Dose of Radioiodine, *J. Agr. Sci.*, **61**: 375 (1963).
22. W. J. Bair, Deposition, Retention, Translocation, and Excretion of Radioactive Particles, in *Inhaled Particles and Vapours*, C. N. Davies (Ed.), Pergamon Press, Inc., New York, 1961.
23. D. H. Willard and W. J. Bair, Behavior of I-131 Following Its Inhalation as a Vapor and as a Particle, *Acta Radiol.*, **55**: 486 (1961).
24. L. K. Bustad, Metabolism of ^{131}I in Sheep and Swine, USAEC Report HW-SA-2267, General Electric Company, 1961.
25. National Academy of Sciences, *Effects of Inhaled Radioactive Particles*, Report of the Subcommittee on Inhalation Hazards, Publication 848, Washington, D. C., 1961.
26. J. Barua, R. G. Cragle, and J. K. Miller, Sites of Gastrointestinal-Blood Passage of Iodide and Thyroxine in Young Cattle, *J. Dairy Sci.*, **47**: 539 (1964).
27. R. G. Cragle, J. K. Miller, and P. T. Chandler, Gastro-Intestinal Sites of Absorption and Secretion of Ca, P, Zn, and I in Dairy Cattle, in *Radioisotopes in Animal Nutrition and Physiology*, Symposium Proceedings, Prague, 1964, International Atomic Energy Agency, Vienna, 1965 (STI/PUB/90).
28. J. K. Miller, E. W. Swanson, P. W. Aschbacher, and R. G. Cragle, Iodine Transfer and Concentration in the Parturient Cow, Fetus, and Neonatal Calf, *J. Dairy Sci.*, **50**: 1301 (1967).
29. National Academy of Sciences, *Damage to Livestock from Radioactive Fallout in Event of Nuclear War*, Report by the Subcommittee on Livestock Damage, Publication 1078, Washington, D. C., 1963.
30. E. W. Swanson, F. W. Lengemann, and R. A. Monroe, Factors Affecting the Thyroid Uptake of ^{131}I in Dairy Cows, *J. Anim. Sci.*, **16**: 318 (1957).

PROBLEMS IN POSTATTACK LIVESTOCK SALVAGE

S. A. GRIFFIN* and G. R. EISELE

Oak Ridge National Laboratory, Oak Ridge, Tennessee, and
UT-AEC Agricultural Research Laboratory, Oak Ridge, Tennessee

ABSTRACT

Studies were initiated in 1968 to determine whether the meat from irradiated animals could be utilized safely by humans in a nuclear disaster. Pigs weighing approximately 200 to 250 lb were exposed to 700 R (air dose) of whole-body gamma irradiation at 1 R/min. Blood samples were taken before and after irradiation to detect bacteremia. No evidence of bacteremia was found in any of the pigs. Various bacteria were isolated from the lymph and liver. In some animals bacteria were isolated from the muscles. No difference in the incidence of bacterial invasion was found between irradiated and control animals.

Not being able to detect bacteremia in pigs, we conducted a pilot study on rats to verify previous work and to evaluate our techniques. Rats exposed to 800, 900, and 1000 R of whole-body gamma irradiation at 50 R/min developed bacteremia, the severity and incidence increasing with the increase in total dose.

A problem of major concern in a postattack situation is that of maximum utilization of available livestock for human food. At present the general recommendations are that animals exposed to radiation can be used for food before they show radiation sickness and after they have recovered (National Academy of Sciences-National Research Council, 1963). However, this procedure may not be feasible under postattack conditions. The literature indicates that animals exposed to a lethal dose of whole-body irradiation may develop bacteremia (bacterial invasion into the circulatory system). However, most of the experimental work has been done with laboratory animals.

Hammond, Anderle, and Miller¹ exposed mice (10-week-old CF-1 females) to three levels of continuous gamma radiation from a ⁶⁰Co source. The animals

*Present address: Dean of Agriculture, Tennessee Technological University, Cookeville, Tenn.

were then challenged by intraperitoneal injection of *Pseudomonas aeruginosa*. These authors concluded that increased susceptibility to this infection was related to rate of irradiation rather than to the total accumulated dose.

Silverman et al.,² using mice exposed to supralethal doses of neutron or combined neutron and gamma radiation from a nuclear device, reported that mice with a short survival time had a larger percentage of positive spleen cultures than of positive heart blood cultures. Similar results were also reported by Gonschery, Marston, and Smith.³ Silverman et al. also concluded that the ability of the spleen to remove bacteria may not be impaired but that it may be unable to destroy the increased number of bacteria and thus bacteremia eventually develops.

Miller, Hammond, and Tompkins⁴ exposed male mice weighing approximately 20 g to 450 or 600 R of total-body X irradiation. The majority of the animals had bacteremia severe enough to be considered an overwhelming sepsis, which was to a large degree responsible for their deaths.

Kossakowski,⁵ working with rabbits exposed to doses of 1000 and 1200 R of X rays, reported no bacteremia during the course of acute radiation sickness. However, the muscles and internal organs showed an increase in bacteria isolated. He concluded that positive results from bacteriological investigation of blood cannot be regarded as an indication of postradiation autoinfection.

Warren and Whipple⁶ obtained negative blood cultures from dogs exposed to a lethal dose of X ray. Lawrence and Tennant⁷ reported that mice exposed to 1000 R of X rays ($LD_{50} = 550$ to 600 R) or equivalent doses of neutrons were bacteriologically clean when killed 1, 2, 3, or 4 days after irradiation. When killed 5 to 11 days postirradiation, mice receiving 700 to 800 R did show positive blood cultures.

Pawel, Kalousova, and Vranovska⁸ reported on bacterial evaluation of meat of slaughtered swine that had received a total dose of 700 R at 100 R/33 min. They concluded:

1. A penetration of germs outside the intestinal tract occurs already in the period of the disease in which the manifest clinical symptoms of acute irradiation sickness are not yet developed.
2. Germs are found first of all in the organs, i.e., particularly in the liver and in the spleen.
3. Among the germs found in irradiated animals we diagnosed no representatives of the principal infectious diseases of pigs caused by bacteria. The majority of the micro-organisms found consisted of coliform germs and streptococci.

In a short-term experiment, Wasserman and Trum⁹ reported that the flesh from lethally irradiated animals (cows and sheep) was not detrimental when ingested by dogs. These authors also reported similar results when meat and/or selected organs were fed to albino rats and chickens.¹⁰

Studies were initiated in 1968 at Oak Ridge to determine whether the meat from lethally irradiated animals could safely be used for human consumption in a nuclear disaster. Our initial objective was to determine whether farm animals

developed bacteremia and if there was further invasion of the organs and muscles.¹¹

EXPERIMENTAL PROCEDURE

The ^{60}Co variable-dose-rate irradiation facility at UT-AEC Agricultural Research Laboratory was used as the radiation source in these studies. A total bilateral exposure dose of 700 R (air dose) at 1 R/min was used. It was estimated that this level of irradiation would approach an $\text{LD}_{80/30}$.

All animals were examined by a veterinarian for any abnormalities or disease prior to irradiation. Complete hematological studies were done before irradiation and at various time intervals after irradiation, especially at the time animals showed visual symptoms of radiation sickness.

Pigs

The procedures for the collection of blood samples, for necropsy, and for microbiological evaluations were the same as those reported by Eisele and Griffin.¹¹ Visual observation was the major method used to determine when the animal was suffering from severe radiation sickness. The following criteria were used:

1. Passage of small amounts of blood in the stool.
2. Slight but continuous discharge of blood from the snout.
3. Impairment of weight gain.
4. Apathy.
5. Muscular weakness and/or excitability.

Fifteen Duroc pigs averaging 200 to 250 lb were exposed to 700 R at 1 R/min and were sacrificed 10 days later under commercial slaughter conditions.¹² Bacteriological studies were carried out on the blood, muscle, liver, and lymph nodes at the time of slaughter. Further bacterial examination was done on the muscle after the carcasses had hung in a cooler for 5 days at 38°F . For chemical analysis at a later date, muscle samples were taken at slaughter and after 5 days in the cooler. These samples were vacuum packed and frozen. The hams from these animals were dry cured and smoked.

Rats

Adult female rats 1 to 2 years old and weighing approximately 300 g were exposed to 800, 900, and 1000 R of whole-body gamma irradiation at 50 R/min. Five controls, 10 irradiated controls, and 15 irradiated and bled rats were used for each level of irradiation. Blood samples were taken via cardiac puncture when the rats showed symptoms of radiation sickness or were in a moribund state.

RESULTS AND DISCUSSION

Pigs

The gross pathological findings at slaughter were multiple ecchymotic and/or petechial hemorrhages in the lungs and throughout the wall and mucosa of the intestines, petechial hemorrhages in the ventral abdominal region, ecchymotic hemorrhages in the stomach (pylorus and/or fundus), and enlarged lymph nodes with peripheral congestion. These findings were quite similar to those in earlier pigs.

Bacteria were isolated from lymph nodes, liver, and muscle (Tables 1 and 2). There were no differences in the percentage of positive samples between the irradiated and control groups. At 5 days postslaughter the carcasses were examined for additional bacterial study. Twenty percent of the samples indicated some type of bacterial growth, but these were not the same carcasses that showed bacterial growth at the time of slaughter.

Table 1
BACTERIA ISOLATED FROM 11 SWINE
EXPOSED TO 700 R AT 1 R/MIN*

Tissue	Number of positive cultures	Positive cultures, %
Lymph	10	91
Liver	3	27
Muscle (sampled at slaughter)	1	9
Muscle (5 days postslaughter)	2	18

*All blood samples were negative.

Table 2
BACTERIA ISOLATED FROM 4 CONTROL SWINE*

Tissue	Number of positive cultures	Positive cultures, %
Lymph	4	100
Liver	1	25
Muscle (sampled at slaughter)	2	50
Muscle (5 days postslaughter)	1	25

*All blood samples were negative.

Since in the previous trials^{1,2} several methods of slaughtering and meat handling were evaluated, the only comparison we can make with these trials is in the incidence of bacteria in the muscle. These comparisons indicate that the meat in the earlier trials was probably contaminated in the handling and preservation, whereas the pigs in this experiment were slaughtered under sanitary conditions and showed virtually no bacterial activity. Thus, in a postattack situation where slaughtering facilities are usable, the degree of microbial activity will be at a minimum provided the meat can also be properly handled and stored. On the other hand, regardless of the slaughtering procedure practiced, if the meat is not properly stored, a buildup of bacteria will occur.

Two hams were cooked to an internal temperature of 180°C and randomly sampled to see if any organoleptic differences could be noticed. All individuals participating in the sampling were informed that one ham was taken from an animal exposed to a lethal dose of gamma radiation and the other ham was a control. The following results were obtained:

Preference	Number
Irradiated ham	46
Control ham	43
Undecided	3
Total number of participants	<hr/> 92

Rats

Inasmuch as we did not observe bacteremia in the pigs, a pilot study was conducted to test our techniques with rats, since the literature indicated that bacteremia did occur in laboratory animals exposed to lethal radiation.

Bacteremia was noted in all groups, the severity and incidence increasing with the increase in total dose (Table 3). This difference in the incidence of bacteremia between the rats and the pigs may be due in part to the different dose rates.

Steers

Bacteriological studies were also carried out on steers receiving various types of radiation insults as a part of the study by Bell, Sasser, and West.^{1,3} Blood samples were taken from nine animals that had received various insults approximately 8 months earlier. All samples were negative.

Bacteriological evaluations were carried out on the liver, lymph, muscle, and spleen of four animals at the time they were sacrificed (Table 4). All these animals had received skin irradiation and had large open sores on the skin. One animal had received a gastrointestinal insult in addition to the skin irradiation, and the damage to the rumen had healed.

Table 3
BACTERIA ISOLATED FROM 15 RATS RECEIVING
DOSES AT 50 R/MIN*

Group	Number of positive cultures	Positive cultures, %	Summary of organisms isolated
1000 R	9	82	<i>Escherichia coli</i> <i>Pseudomonas</i> species <i>Proteus</i> species <i>Bacillus subtilis</i> Beta-hemolytic <i>Streptococcus</i>
900 R	10	75	<i>Escherichia coli</i> <i>Aerobacter aerogenes</i> <i>Bacillus subtilis</i> Beta-hemolytic <i>Streptococcus</i> Gamma-hemolytic <i>Streptococcus</i>
800 R	9	60	<i>Escherichia coli</i> <i>Aerobacter aerogenes</i> <i>Proteus</i> species Beta-hemolytic <i>Streptococcus</i> <i>Staphylococcus aureus</i>

*All control rats had negative blood cultures.

CONCLUSIONS

From these studies it appears that bacteremia was not present in the swine; this indicates that the reticuloendothelial system was not impaired to such an extent that bacterial invasion occurred. The low incidence of positive cultures of the liver also suggests that a bacteremia did not occur.

Additional trials with pigs will be carried out at a dose rate of 45 R/min, and steers will be studied at the 1- and 45-R/min dose rates. These animals are now available, and the experiments will be completed this year.

ACKNOWLEDGMENTS

Oak Ridge National Laboratory is operated by Union Carbide Corporation for the U. S. Atomic Energy Commission.

Table 4
BACTERIOLOGICAL FINDINGS FROM STEERS
EXPOSED TO RADIATION INSULTS

Steer number	Type of irradiation	Time of evaluation	Tissue sample	Bacteriological findings
138	Skin	9 months after irradiation	Muscle	Negative
			Spleen	Negative
			Liver	<i>Escherichia coli</i> <i>Bacillus subtilis</i> <i>Staphylococcus albus</i>
			Lymph	Beta-hemolytic <i>Streptococcus</i> <i>Staphylococcus albus</i> <i>Pseudomonas</i> species
135	Skin	10 months after irradiation	Muscle	Negative
			Spleen	Negative
			Liver	Beta-hemolytic <i>Streptococcus</i> <i>Bacillus subtilis</i> <i>Sarcina</i> species
			Lymph	<i>Staphylococcus albus</i> Beta-hemolytic <i>Streptococcus</i> Nonhemolytic <i>Streptococcus</i>
151	Skin and whole body	9 months after irradiation	Muscle	Negative
			Spleen	Negative
			Liver	<i>Pseudomonas</i> species <i>Staphylococcus albus</i>
			Lymph	Negative
152	Skin and gastrointestinal	10 months after irradiation	Muscle	Negative
			Spleen	Negative
			Liver	Beta-hemolytic <i>Streptococcus</i>
			Lymph	<i>Escherichia coli</i> <i>Aerobacter aerogenes</i> <i>Staphylococcus albus</i>

The UT-AEC Agricultural Research Laboratory is operated by the Tennessee Agricultural Experiment Station for the U. S. Atomic Energy Commission under Contract AT-40-1-GEN-242.

This work was sponsored by the U. S. Atomic Energy Commission and is published with the permission of the Dean of the University of Tennessee Agricultural Experiment Station, Knoxville.

REFERENCES

1. C. W. Hammond, S. K. Anderle, and C. P. Miller, Effect of Continuous Gamma Irradiation of Mice on Their Leukocyte Counts and Susceptibility to Bacterial Infection, *Radiat. Res.*, 11: 242-252 (1959).

2. M. S. Silverman, V. P. Bonx, V. Greenman, and P. H. Chin, Bacteriological Studies on Mice Exposed to Supralethal Doses of Ionizing Radiations. I. Radiation from a Nuclear Device, *Radiat. Res.*, **7**: 270–276 (1957).
3. L. Gonsbery, R. Q. Marston, and W. W. Smith, Naturally Occurring Infections in Untreated and Streptomycin-Treated X-Irradiated Mice, *Amer. J. Physiol.*, **172**: 359–364 (1953).
4. C. P. Miller, C. W. Hammond, and M. Tompkins, The Role of Infection in Radiation Injury, *J. Lab. Clin. Med.*, **38**: 331–343 (1951).
5. S. Kossakowski, The Investigations on the Possibility of Vital Diagnosis of Post-Radiation Autoinfection in Slaughter Animals, *Med. Wet. (Poland)*, **24**: 449–453 (1968). (In Polish) *Nuclear Science Abstracts*, **24**: 877, Jan. 15, 1970.
6. S. L. Warren and G. H. Whipple, Roentgen Ray Intoxication. I. Bacterial Invasion of the Blood Stream as Influenced by X-Ray Destruction of the Mucosal Epithelium of the Small Intestine, *J. Exp. Med.*, **38**: 713–721 (1923).
7. J. H. Lawrence and R. Tennant, The Comparative Effects of Neutrons and X-Rays on the Whole Body, *J. Exp. Med.*, **66**: 667 (1937).
8. O. Pawel, V. Kalousova, and J. Vranovska, Results Obtained in Microbiological Tests of Meat and Slaughtered Swine Afflicted by Radiation Sickness, *Vet. Med. (Prague)*, **12**: 361–366 (1967).
9. R. H. Wasserman and B. F. Trum, Effect of Feeding Dogs the Flesh of Lethally Irradiated Cows and Sheep, *Science*, **121**: 894–896 (1955).
10. B. F. Trum and R. H. Wasserman, Progress Report to the Office of the Surgeon General, U. S. Army, September 1954.
11. G. Eisele and S. A. Griffin, Problems of Livestock Salvage, in Annual Progress Report, Civil Defense Research Project. March 1968–March 1969, USAEC Report ORNL-4413, Part 1, pp. 97–100, Oak Ridge National Laboratory, October 1969.
12. G. Eisele and S. A. Griffin, Problems of Livestock Salvage, in Civil Defense Research Project Annual Progress Report. March 1969–March 1970, USAEC Report ORNL-4566(Pt. 1), Oak Ridge National Laboratory.
13. M. C. Bell, L. B. Sasser and J. L. West, Simulated-Fallout-Radiation Effects on Livestock, this volume.

EXPOSURE-RATE EFFECTS ON SOYBEAN PLANT RESPONSES TO GAMMA IRRADIATION

M. J. CONSTANTIN, D. D. KILLION, and E. G. SIEMER*
UT-AEC Agricultural Research Laboratory, Oak Ridge, Tennessee

ABSTRACT

Seedlings of *Glycine max* (L.) Merrill were gamma irradiated at either 2 to 3 or 12 days postemergence and scored for seedling growth reduction at either 25 to 30 days postemergence or for stem length at various times through maturity and yield. The results showed an exposure-rate effect the extent of which was dependent on exposure, stage of development when irradiated, and/or the end point scored. Seedling responses showed a rate saturation at 50 R/min, whereas the mature-plant responses showed a rate saturation at 25 R/min. Shoot dry weight was decreased to 50% of control by 3 kR at 50 R/min and by 5 kR at 10 R/min. Yield was reduced to approximately 50% of control by 2.5 kR at from 6.25 to 50 R/min. At 5.0 kR, yield was approximately 20% of control at 6.25 R/min, 10% at 12.5 R/min, and essentially zero at 25 and 50 R/min. Results of a split-exposure experiment demonstrated repair, which occurred within a radiation-free period of 30 to 120 min at an exposure of 4 kR. Decreasing the exposure rate from 36.4 to 20 R/min permitted a greater degree of repair to occur in the plants than occurred during a split exposure of 4 kR at 50 R/min with a radiation-free period of 120 min.

Sparsely ionizing radiation delivered at low rates is less effective in living systems than radiation at high rates; i.e., there is a dose-rate effect. Evidently the magnitude of dose-rate effects in living organisms depends partly on dose of ionizing radiation^{1,2} and on end point scored.¹ The extent of radiation-induced damage observed in an organism is the sum of direct and indirect effects minus repair and recovery that may occur during as well as after irradiation. It has been shown that repair processes are responsible for the extent of dose-rate effects in living systems (see reviews by Casarett³ and Sacher⁴). Dose-rate effects have been

*Present address: Mountain Meadow Research Laboratory, Colorado State University, Gunnison, Colo.

investigated more extensively in mammalian than in botanical systems. (For recent compilation of pertinent data, see the Proceedings of a Conference on Dose Rate in Mammalian Radiation Biology, Apr. 29–May 1, 1968, Oak Ridge, Tenn., USAEC Report CONF-680410, UT–AEC Agricultural Research Laboratory, 1968.) There is, however, ample evidence in the literature that dose-rate effects occur in botanical systems.^{2,5-10}

The extensive research data of Sparrow et al.¹⁰ demonstrate the extent of differential response to ionizing radiation among species of plants and among developmental stages of the life cycle within species as influenced by exposure procedures and environmental conditions. Our research with plants of major food crops, which is of a civil-defense nature, has provided results that concur with this statement. Most of the work, however, was done at an exposure rate of 50 R/min, which is considerably higher than that expected in areas of radioactive fallout. Currently emphasis is being placed on studies involving exposure and exposure rates at different plant developmental stages in a number of species.

In this report of progress, we present data on the response of soybean plants [*Glycine max* (L.) Merrill] to varying gamma-ray exposures as influenced by exposure rate. Results of split-exposure experiments are presented as evidence of repair processes that occur in the soybean plant and as one explanation for the exposure-rate effect observed.

MATERIALS AND METHODS

The experiments were conducted in two phases, one involving seedling growth of the variety Hill under environment-controlled conditions and the other involving plant growth and yield of the variety Kent under outdoor conditions. Plants in both cases were grown in a Perlite : soil : peat : sand medium (3 : 2 : 1 : 1 by volume) with the pH adjusted to approximately 6.5 and with nutrients added. The ⁶⁰Co variable-dose-rate facility of the UT–AEC Agricultural Research Laboratory was used for all experiments.

In the seedling experiments four seeds were planted in each 6-in. pot, and the plants were thinned to two per pot at the time of irradiation. Plants were irradiated on day 2 or 3 postemergence, at which time the primary (unifoliolate) leaves were unfolding. Plants were removed from the environment-controlled room, taken to the ⁶⁰Co source, irradiated, and then returned to the environment-controlled room (83 ± 2°F, 16 hr of light daily, and 50 ± 10% relative humidity). The different exposures and exposure rates caused the duration of irradiation to vary; therefore plants of all treatments were subjected to equal periods of time in the source building at a light intensity and temperature regime less than that in the environment-controlled room. Sham controls were grown for each experiment. In the split-exposure experiment, light intensity and temperature in the source building were equal to those in the

environment-controlled room. Plants were harvested at 25 to 30 days postirradiation, and data presented are oven-dried weights of the shoot above the unifoliolate leaves. Axillary shoot growth is not included.

In the outdoor experiments four plants were grown per 55-gal drum, which was cut in half crosswise. The plants were irradiated at 12 days after emergence; exposures were 2.5 and 5.0 kR at either 6.25, 12.5, 25, or 50 R/min. The criteria of evaluation for plant response to gamma rays were stem length at varying times postirradiation and yield. Late planting caused the plants to be subjected to a killing frost prior to complete maturity; therefore, "yield" refers to the oven-dried weight of pods and immature beans. "Stem length" refers to the distance between the tip of the shoot apex and "ground" level.

RESULTS

A preliminary experiment (data not shown) with seedlings of Hill soybeans exposed to gamma rays at 5, 50, and 500 R/min indicated little or no exposure-rate effect at 2 kR, and at 4 kR the response became independent of rate (the point at which response becomes independent of rate is hereafter referred to as exposure-rate saturation) at 50 R/min. A number of experiments have been conducted since then with exposure rate being one of the variables. Results in Fig. 1 show that shoot weight of soybean seedlings exposed to 4 kR at rates of from 3.125 to 400 R/min reached a rate saturation at approximately 50 R/min.

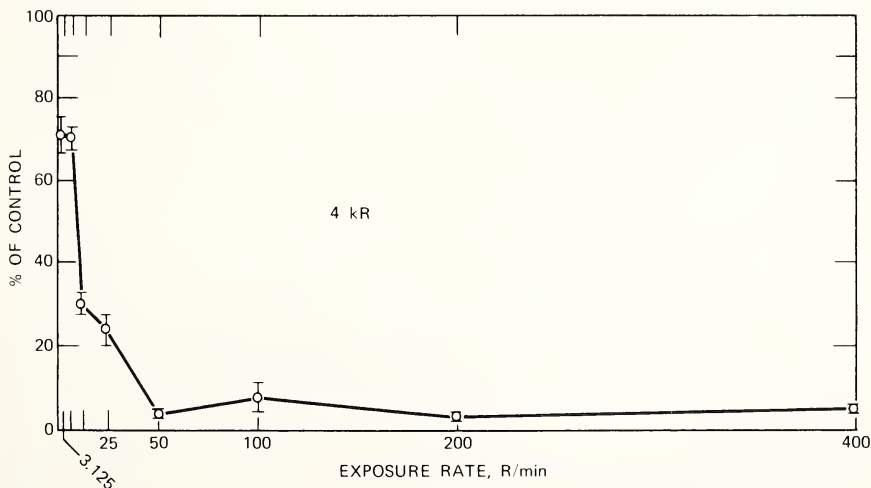

Fig. 1 Shoot dry weight of Hill soybean seedlings as influenced by 4 kR of ⁶⁰Co gamma radiation administered at exposure rates of 3.125 to 400 R/min.

The results of another experiment (Fig. 2) show the relation that exists between exposure and exposure rate for soybean seedling response to gamma rays. Shoot dry weight was reduced to 50% of control (unirradiated) by either 3 or 5 kR, depending on whether the rate was 50 or 10 R/min, respectively. The magnitude of the interaction of exposure and exposure rate can be demonstrated by the ratio of shoot dry weight expressed as percent of control for the 10 R/min vs. the 50 R/min population. The ratios were 1.1, 6.8, 7.0, and 3.6 at 2, 4, 6, and 8 kR, respectively.

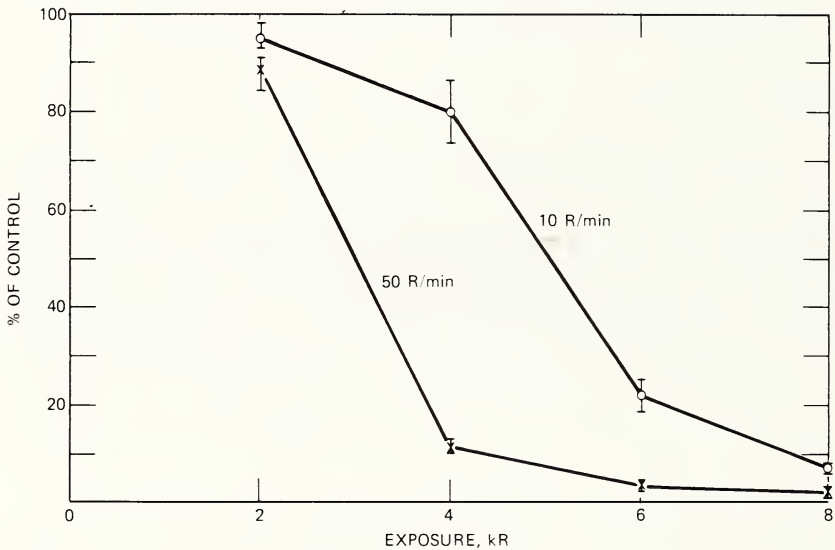

Fig. 2 Influence of exposure on the magnitude of exposure-rate effect demonstrated by shoot dry weight of Hill soybean seedlings following ^{60}Co gamma irradiation.

An outdoor experiment with Kent soybeans was scored for (1) increase in stem length vs. time after irradiation, (2) stem length at maturity, and (3) yield. Results for indexes 1 and 2 are shown in Fig. 3. The seedlings were irradiated at 0 on the abscissa, which was 12 days postemergence (early log phase of growth). The plants ceased to increase in stem length at various times after irradiation; this response was dependent on exposure and exposure rate. At 2.5 kR stem length ceased to increase after 20 to 25 days postirradiation regardless of the exposure rate used. At 5 kR stem length ceased to increase after either 20 to 25 days postirradiation at 6.25 and 12.5 R/min or 5 to 7 days at 25 and 50 R/min. Stem length at maturity (54 days postirradiation) at 2.5 kR was approximately 50% of the controls and was unaffected by the various rates used. Stem length at maturity at 5 kR was 45 and 38% of control at 6.25 and 12.5 R/min and 19 and

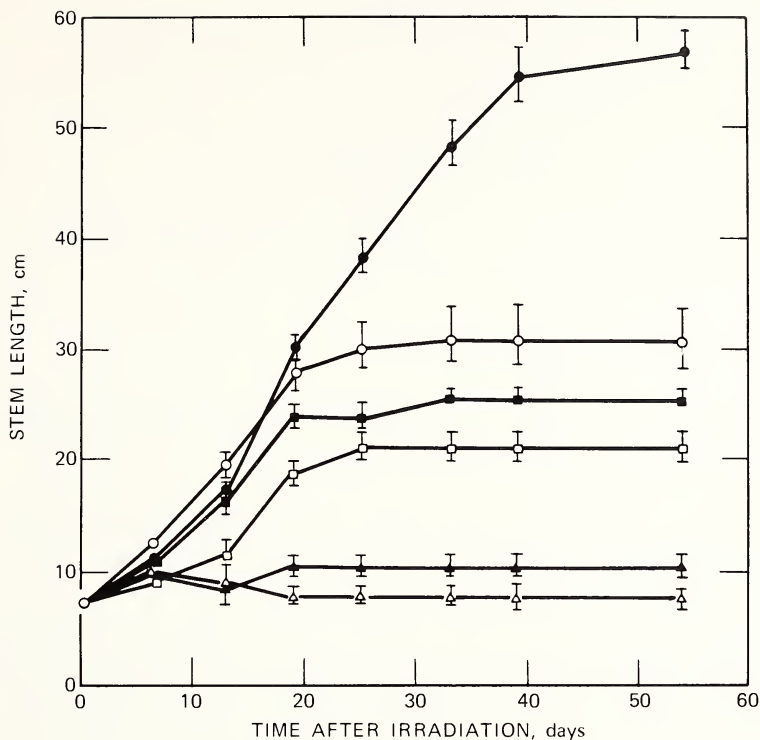

Fig. 3 The effects of 2.5 and 5.0 kR of ^{60}Co gamma radiation, as influenced by exposure rate, on (1) the increase in stem length vs. time after irradiation and (2) stem length at maturity (54 days postirradiation) in Kent soybean plants irradiated at 12 days postemergence.

Symbol	Exposure, kR	Exposure rate, R/min
●	0	0
○	2.5	6.25*
■	5	6.25
□	5	12.5
▲	5	25
△	5	50

*There was no difference among exposure rates at 2.5 kR; therefore a single curve is shown.

14% of control at 25 and 50 R/min, respectively. Thus it appears that for indexes 1 and 2 an exposure-rate saturation had been attained by 25 R/min.

The third index of radiation response of these plants, yield, is shown in Fig. 4. Results of an analysis of variance indicate that at 2.5 kR yield was greater

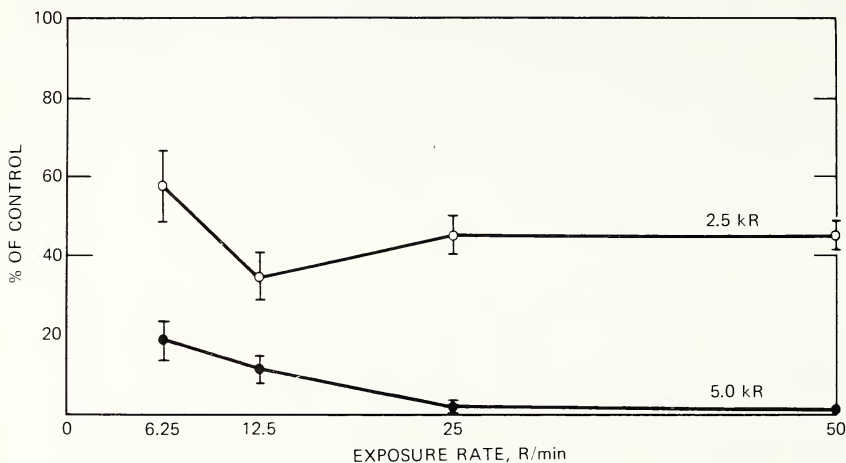

Fig. 4 The effects of 2.5 and 5.0 kR of ^{60}Co gamma radiation, as influenced by exposure rate, on the yield of Kent soybean plants irradiated at 12 days postemergence.

at 6.25 R/min ($P < 0.05$) than at either 12.5, 25, or 50 R/min. This indicates that yield at this exposure showed a rate saturation at 12.5 R/min. However, at 5.0 kR there was no difference in yield at $P \leq 0.05$ between plants exposed at 6.25 and 12.5 R/min, and at 25 and 50 R/min there was essentially no yield.

Results of experiments with split vs. continuous irradiation are shown in Table 1. The split exposures were done at a rate of 50 R/min, and the radiation-free periods were 30, 60, and 120 min. Rates for continuous exposures varied in accordance with total time of the different split-exposure treatments. Neither the duration of the radiation-free period in split exposures nor the exposure rate in continuous exposures caused any differences in the shoot dry weight of seedlings exposed to 2 kR (Table 1).

In contrast to the results observed following 2-kR exposures, an increase in shoot dry weight was observed as the radiation-free period was extended from 30 to 60 min at 4 kR (Table 1). An increase in radiation-free time to 120 min caused only a slight further increase in performance. A comparison of split vs. continuous exposures shows that a decrease in exposure rate (continuous exposures) from 36.4 to 20 R/min had a greater influence on seedling performance than did the increase in radiation-free period (split exposures at 50 R/min) from 30 to 120 min.

DISCUSSION

Sparrow et al.¹⁰ emphasized that a large biological effect can be produced in one species by the same dose or dose rate that produces a negligible effect in

Table 1

SHOOT DRY WEIGHT OF HILL SOYBEAN SEEDLINGS AS
INFLUENCED BY 2 AND 4 kR OF ^{60}Co GAMMA RAYS ADMINISTERED
EITHER AS A SPLIT OR A CONTINUOUS EXPOSURE*

Type of exposure	Exposure rate, R/min	Radiation-free period, min	Exposure period, min	Shoot dry weight, † % of control
2 kR				
Split	50	30	70	88.1 ± 2.8
Continuous	28.6	0	70	84.3 ± 6.2
Split	50	60	100	81.2 ± 4.1
Continuous	20	0	100	88.3 ± 3.4
Split	50	120	160	86.7 ± 5.8
Continuous	15.4	0	160	86.8 ± 5.5
4 kR				
Split	50	30	110	15.9 ± 2.4
Continuous	36.4	0	110	15.5 ± 1.4
Split	50	60	140	34.4 ± 3.2
Continuous	28.6	0	140	42.6 ± 4.3
Split	50	120	200	39.5 ± 3.2
Continuous	20.0	0	200	60.3 ± 3.3

*Exposure rates were adjusted to provide the same total duration of irradiation.

†Values are the mean per treatment ± standard error.

another species. In a later publication Sparrow et al.¹¹ demonstrated the range in exposures (acute) and in exposure rate (roentgens per day for chronic exposure) which induces lethality and/or varying degrees of growth suppression in a large number of species. The species response was correlated to average interphase chromosome volume, and it was shown that on the basis of absorbed energy (electron volts) per interphase chromosome the species do not vary for comparable levels of damage.¹¹ By extrapolation one could infer that this relation would hold true for exposure-rate effects observed during acute irradiations on the basis of energy absorbed per interphase chromosome per minute instead of per day. Thus sensitive species would undergo a saturation at lower exposure rates than tolerant species when considered in terms of roentgens rather than electron volts absorbed. Recently Bottino and Sparrow⁵ have reported a constant ratio of 1.4 between simulated-fallout-decay rate over a 36-hr period and 16-hr constant-rate exposures for lethality and yield reduction in plants of eight species. Furthermore, they reported that 8-hr constant-rate exposures were equal to the simulated-fallout-decay rate for the eight species.

The results presented here for soybean seedlings indicate a rate saturation at approximately 50 R/min for seedling studies (Fig. 1) and 25 R/min for stem length at maturity and for yield (Figs. 3 and 4)—two different types of end points. It should be noted, however, that these data were obtained from experiments with different varieties of plants at slightly different stages of development. If we can assume that varietal differences will be minimal, then we can infer an effect of stage of development and/or end point on the rate-saturation phenomenon.

Our results concur with those of McCrory and Grun,² who have reported a relation between dose and dose rate in diploid, hybrid clones of *Solanum*. A similar relation between dose and dose rate and end point and dose rate has been reported in experiments with mice.⁵ Cromroy¹² alluded to the problems created by dose-rate effects when cross comparisons are made either within or among species. Krebs and Leong¹³ concluded from recent experiments with mice that (1) there was no change in LD_{50/4} when exposure rate was 3500 R/hr or higher, (2) LD_{50/4} practically doubled with a decrease from 3500 to 400 R/hr, and (3) there was little or no change in LD_{50/4} when exposure rate was below 400 R/hr. The limited data we have on D₅₀ at different rates (results in this report and unpublished data) indicate a trend similar to conclusions 1 and 2 above. We have too few D₅₀ values for rates below 10 R/min to determine whether our results will also show a plateau response at low rates. Results in Fig. 1 indicate that a plateau may be reached; however, Fig. 1 shows the response instead of the exposure required to induce a particular level of response.

A rate-saturation constant for species of organisms based on their interphase chromosome volume would be valuable to explain certain radiobiological phenomena. Cromroy¹² reports the interphase chromosome volume of laboratory white mice as approximately $2.25 \mu^3$, and the results of Krebs and Leong¹³ indicate for the mouse a rate saturation at 3500 R/hr for LD_{50/4} caused by gastrointestinal damage. Hill soybean seedlings at 2 days postemergence have an interphase chromosome volume of $2.95 \mu^3$ and show a rate saturation at approximately 50 R/min for exposure required to reduce shoot dry weight to 50% of control. For end points scored later in the life cycle of the plant, however, a rate saturation was reached at 25 R/min. Also, the *Solanum* hybrids used by McCrory and Grun² have an interphase chromosome volume of $6.48 \mu^3$ and show a rate saturation at 70 R/min for lethality at an exposure of 9 kR. Further research may be justified because it is known that some interspecific hybrids deviate from expected radiosensitivity based on their interphase chromosome volume.¹¹ Sparrow et al.¹⁰ have shown that the required energy absorbed per interphase chromosome varies within a species in accordance with the end point and level of response. It is known also that changes in nuclear and interphase chromosome volumes occur during the mitotic cycle of cells¹⁴ and with seasonal changes in forest trees.¹⁵

The data in Table 1 for split vs. continuous exposures for the same length of time indicate that repair takes place in the soybean seedling. This does not

preclude the occurrence of recovery in the plant after irradiation. Table 1 data show a lack of a detectable repair at 2 kR with either split exposures or lowering the rate from 28.6 to 15.4 R/min. Also, there was no difference in shoot dry weight between split and continuous exposures delivered during the same time period. This agrees with the results in Fig. 2, which indicate the lack of an exposure-rate effect at 2 kR and also with results in the literature.^{5,7}

At 4 kR an increase in shoot dry weight was observed with an increase in radiation-free time from 30 to 60 min, and an extension to 120 min caused only a slight further increase. It is inferred that repair processes reached a maximum expression within approximately 60 min for the conditions of exposure and exposure rate used. Apparently changes in exposure and exposure rate in split-exposure experiments would alter the extent of repair and the time during which it occurs (refer to Krebs and Leong¹³ for data on mice). Results with exposures of 4 kR at 50 R/min (Figs. 1 and 2) and at 50 R/min split exposure with 30 min of radiation-free time are approximately equal; this indicates that little repair occurred during a 30-min period. Contrary to most results in the literature, we observed a greater increase in shoot dry weight (from 15.5 to 60.3% of control) by decreasing exposure rate from 36.4 to 20 R/min than that for split exposures with a radiation-free period of 60 and 120 min (Table 1). Since we have only the results of this experiment without any knowledge of the repair mechanism, it appears that further discussion of the phenomenon in the soybean seedling is unwarranted at this time.

One last comment is warranted concerning a problem pertinent to research involving growth of seedlings (fresh and dry weight or stem length) following irradiation. Results shown in Fig. 3 demonstrate the fallacy inherent to a comparison of the data from experiments scored at different arbitrary times after treatment. To illustrate the point, consider the differences in stem length among plants of the various treatments when it was measured at intervals from 5 to approximately 25 days after irradiation. The response shows minimal effects of exposure and rates at 5 days and maximal effects from 25 days on. The time course of events would probably vary according to when the organism was irradiated, the species, and the environmental conditions.

ACKNOWLEDGMENTS

The UT-AEC Agricultural Research Laboratory is operated by the Tennessee Agricultural Experiment Station for the U. S. Atomic Energy Commission under Contract AT-40-1-GEN-242.

This work was supported by funds from the U. S. Office of Civil Defense and is published with the permission of the Dean of the University of Tennessee Agricultural Experiment Station, Knoxville.

REFERENCES

1. S. Hornsey and T. Alper, Unexpected Dose-Rate Effect in the Killing of Mice by Radiation, *Nature*, **210**: 212-213 (1966).
2. G. J. McCrory and P. Grun, Relationship Between Radiation Dose Rate and Lethality of Diploid Clones of *Solanum*, *Radiat. Bot.*, **9**(1): 27-32 (1969).
3. A. P. Casarett, *Radiation Biology*, pp. 244-247, Prentice-Hall, Inc., Englewood Cliffs, N. J., 1968.
4. G. A. Sacher, Repairable and Irreparable Injury: A Survey of the Position in Experiment and Theory, in *Radiation Biology and Medicine*, Walter C. Claus (Ed.), pp. 283-313, Addison-Wesley Publishing Company, Inc., Reading, Mass., 1958.
5. P. J. Bottino and A. H. Sparrow, Comparison of the Effects of Simulated Fallout Decay and Constant Exposure Rate Treatments on the Survival and Yield of Agricultural Crops, in Proceedings of the 4th International Congress of Radiation Research, Evian, France, p. 30 (Abstract), 1970.
6. M. J. Constantin, The Relative Advantages of Fast Neutron Irradiation to Induce Bud Sprouts in Ornamental Plants, in Proceedings of the 4th International Congress of Radiation Research, Evian, France, in preparation, 1970.
7. P. Pereau-Leroy, Facteurs affectant la déchimérisation par irradiation gamma chez l'oeillet, *Bulletin de la société botanique de France, Colloque de morphologie expérimentale*, pp. 55-60 (1967).
8. A. H. Sparrow, Comparisons of the Tolerances of Higher Plant Species to Acute and Chronic Exposures of Ionizing Radiation, *Jap. J. Genet.*, **40**(Supplement): 12-37 (1965).
9. A. H. Sparrow and L. Puglielli, Effects of Simulated Radioactive Fallout Decay on Growth and Yield of Cabbage, Maize, Peas, and Radish, *Radiat. Bot.*, **9**(2): 77-92 (1969).
10. A. H. Sparrow, R. L. Cuany, J. P. Miksche, and L. A. Schairer, Some Factors Affecting the Responses of Plants to Acute and Chronic Radiation Exposures, *Radiat. Bot.*, **1**(1): 10-34 (1961).
11. A. H. Sparrow, R. C. Sparrow, K. H. Thompson, and L. A. Schairer, The Use of Nuclear and Chromosomal Variables in Determining and Predicting Radiosensitivities, from Technical Meeting on the Use of Induced Mutations in Plant Breeding, Rome, 1964. [*Radiat. Bot.*, **5** (Supplement): 101-132 (1965)].
12. H. L. Cromroy, Mammalian Radiosensitivity. Final Report for the Office of Civil Defense, Contract Number N00228-68-C-2658, p. 22, 1969.
13. J. S. Krebs and G. F. Leong, Effect of Exposure Rate on the Gastrointestinal LD₅₀ of Mice Exposed to ⁶⁰Co Gamma Rays or 250 kVp X-Rays, *Radiat. Res.*, **42**: 601-613 (1970).
14. H. Swift, Quantitative Aspects of Nuclear Nucleoproteins, *Int. Rev. Cytol.*, **2**: 1-76 (1953).
15. F. G. Taylor, Jr., Nuclear Volume Changes in Southeastern Tree Species Before Spring Growth, *Radiat. Bot.*, **5**(1): 61-64 (1965).

EFFECTS OF ACUTE GAMMA IRRADIATION ON DEVELOPMENT AND YIELD OF PARENT PLANTS AND PERFORMANCE OF THEIR OFFSPRING

E. G. SIEMER,* M. J. CONSTANTIN, and D. D. KILLION
UT-AEC Agricultural Research Laboratory, Oak Ridge, Tennessee

ABSTRACT

The effects of acute gamma irradiation on the development and yield of soybean, rice, and corn plants were determined. Plants were grown in containers outdoors and exposed once during their life cycle to ^{60}Co gamma radiation at 50 R/min. Performance of their offspring was determined under greenhouse conditions.

Yield of soybean plants receiving 2.5 kR was either unaffected or reduced to approximately 50% of control depending on their stage of development when irradiated. At early bloom 1 kR reduced yield significantly and 3 kR eliminated it. Two weeks later, during late bloom, 2 kR reduced yield significantly and 6 kR eliminated it. Branch abscission was a factor in the reduction of seed yield in soybeans.

Yield of rice plants exposed to 25 kR was either reduced or eliminated depending on the stage of development when the plants were irradiated. The plants were most sensitive to radiation during the time from panicle initiation to anthesis. When plants were irradiated in small peat pots 2 days after emergence (DAE) with minimal radiation attenuation to the shoot meristem, 5 kR reduced yield significantly and 15 kR eliminated it.

An exposure of 2.5 kR essentially eliminated yield of a corn plant irradiated during the period from tassel initiation through silking. An exposure of 500 R reduced yield significantly when 1-DAE plants were irradiated in small peat pots. Periods of relative tolerance to gamma irradiation were observed during early vegetative phase when sucker proliferation occurred and just prior to pollination and fertilization.

It appears that, if the parent plant produces seed when it is irradiated prior to fertilization and embryogenesis, emergence and seedling growth of the offspring will be normal. If the parent plant produces seed when it is irradiated after fertilization, however, emergence and seedling growth of the offspring will reflect the decrease in sensitivity of the developing embryo.

*Present address: Mountain Meadow Research Center, Colorado State University, Gunnison, Colo.

The degree of damage suffered by food-crop plants subjected to radioactive fallout from nuclear war would depend on many factors, including kinds of radiation, exposure, exposure rate, stage of plant development, and environmental conditions.^{1,2} Irradiation may either inhibit or alter development of the vegetative and reproductive structure of the parent plant and development of the embryo and food-storage tissues in the seed. These factors contribute to making seed yield, the primary end product of agronomic food crops, relatively sensitive to ionizing radiation. Bell and Cole³ referred to the lack of information pertinent to the prediction of the magnitude of yield reduction to be expected if crop plants were subjected to radioactive fallout. In this report we present data to show the effects of exposure and stage of development on the yield of corn, rice, and soybean plants exposed once during their life cycle to ⁶⁰Co gamma radiation. Morphogenetic data for nonirradiated (control) and irradiated populations of plants are presented to help explain the degree of yield reduction observed. Data on emergence and growth of offspring are presented also to assess the effects of irradiation on the establishment of a crop the following year.

MATERIALS AND METHODS

Plants of corn (*Zea mays* L. 'WF-9 × 38-11'), rice (*Oryza sativa* L. 'CI-8970-S'), and soybean [*Glycine max* (L.) Merrill 'Hill' and 'Kent'] were grown to maturity under outdoor conditions in containers (55-gal drums cut in half crosswise). The growth medium was a soil : Perlite : peat mixture (2 : 2 : 1 by volume) for the 1968 studies, and a soil : Perlite : peat : sand mixture (2 : 3 : 1 : 1 by volume) for the 1969 studies. Nitrogen, phosphorus, and potassium were added to maintain vigorous plant growth, and the plants were irrigated as needed.

All irradiations were done at the ⁶⁰Co variable-dose-rate irradiation facility of the UT-AEC Agricultural Research Laboratory. Since young seedlings of corn and rice have their shoot meristem below ground level, when they were irradiated, the metal container, growth medium, and water attenuated the gamma radiation that reached the shoot meristem. Dosimetry indicated that the extent of radiation attenuation was approximately 65% at a vertical depth of 2.5 cm and that the attenuation increased sharply within the first centimeter below the surface. (The attenuation was caused by the horizontal rather than the vertical distance through the medium traversed by the radiation.) The shoot meristem of corn and rice reached the surface approximately 3 weeks after emergence, and thereafter there was no problem of radiation attenuation by the medium. To study the response of young seedlings of corn and rice without the problem of attenuation, we grew and irradiated seedlings in small peat pots and then transplanted them into the containers. Attenuation was less than 10% for plants in these experiments. The root system of all plants received less radiation than did the aboveground parts.

Emergence and growth of the offspring from seeds harvested from parent plants subjected to different radiation treatments were determined in greenhouse benches using the same growth medium as in the containers.

The development of control plants was studied in detail by dissection of three or more plants at each time of irradiation. Data were collected on the growth of the vegetative and reproductive structures of the plant, and the time of occurrence of such events as flower-bud initiation, anthesis, fertilization, etc., was noted.

More-specific details concerning methodology are included in the presentation of results for each crop.

RESULTS

Soybeans

Results of the 1968 studies with Hill soybean plants are shown in Table 1. The length of the primary stem was affected most severely during the period from 3 to 24 days after emergence (DAE); the extent of damage decreased with time from 24 to 41 DAE, and, from 45 to 62 DAE, stem length of the irradiated plants was greater than that of the control plants. Bean yield was affected most severely when the plants were irradiated at their earliest seedling stages and at the time of early blooming. As the plant developed its vegetative structures during the period from 3 to 17 DAE, it became more resistant to gamma irradiation. The plant became increasingly sensitive to gamma radiation from the time of flower-bud initiation to the time of early bloom (45 DAE). Thereafter resistance to gamma radiation increased; this reflects the increasing tolerance of the developing embryo and the increase in development of the food-storage tissues in the seed. Studies of the offspring indicate that percent of emergence and growth were affected only slightly when the parent plants were exposed to 2.5 kR at 50 R/min prior to the time of fertilization, the period from 3 to approximately 38 DAE. In general, percent of emergence decreased by approximately 40% when the parent plants were irradiated during the period from 41 to 62 DAE. A similar trend was observed for seedling growth as measured by dry weight of the seedling at 18 DAE.

Data from exposure-response studies of Hill soybean plants at 46 DAE (early-blooming stage) and at 60 DAE (late-blooming stage) are listed in Tables 2 and 3. Stem length showed a maximum reduction of approximately 30% at 46 DAE even at an exposure of 10 kR; however, at 60 DAE stem length was increased up to 22% above the controls, and none of the exposures used caused a reduction. Plants exposed to 3 kR or more did not undergo senescence (i.e., they did not shed their leaves) at the same time as the control plants. This response was probably associated with the decrease and elimination of bean development. The number of pods per plant was reduced by 50% at approximately 5.5 kR at

Table 1

EFFECTS OF EXPOSURE OF HILL SOYBEAN PLANTS TO ^{60}Co GAMMA RADIATION (2.5 kR AT 50 R/MIN) ON STEM LENGTH AND BEAN YIELD OF PARENT PLANTS AND ON EMERGENCE AND OVEN-DRIED WEIGHT OF OFFSPRING*

Time of irradiation, DAE	Parents				Offspring	
	Length of primary stem		Yield of beans		Emergence, ‡ %	Weight, § g
	cm†	% of control	Weight, † g	% of control		
3	23	40	4.6	11	92	0.091
4	28	49	5.0	12	96	0.068
6	24	42	11.6	29	96	0.066
7	26	46	11.4	28	84	0.064
10	25	44	7.0	17	72	0.058
11	23	40	24.0	59	84	0.090
12	25	44	10.0	25	88	0.073
13	24	42	19.0	47	88	0.076
14	26	46	21.0	52	88	0.084
17	27	47	30.0	74	96	0.082
20	29	51	22.0	54	84	0.070
24	17	30	18.1	45	88	0.072
27	33	58	22.4	55	64	0.084
31	29	51	11.0	27	92	0.090
34	37	65	16.0	40	72	0.078
38	44	77	10.3	26	96	0.077
41	57	100	9.0	22	64	0.049
45	53	93	7.3	18	64	0.052
48	67	118	8.3	21	84	0.059
55	68	119	22.2	55	60	0.030
62	65	114	25.5	63	68	0.033
Control	57	100	40.4	100	92	0.072

*Three plants per container and one container per treatment.

†Mean per plant.

‡ Number of seedlings emerged divided by number of seeds planted times 100.

§ Mean oven-dried weight per seedling at 18 DAE.

46 DAE, but at 60 DAE there was no reduction for the exposures used. The yield of beans at 46 DAE was negligible at 3 kR and above, whereas at 60 DAE yield became negligible at 6 kR and above. No beans were harvested from 46 DAE plants, and few beans were harvested from 60 DAE plants exposed to 6 kR or more.

Because the soybean experiment had to be replanted two times in 1969 the lateness of the last planting necessitated a switch to Kent, which is a short-season

Table 2

EFFECTS OF EXPOSURE OF HILL SOYBEAN PLANTS TO ^{60}Co GAMMA RADIATION (1 TO 10 kR AT 50 R/MIN) AT 46 DAE, i.e., EARLY-BLOOMING STAGE, ON STEM LENGTH, NUMBER OF PODS, AND BEAN YIELD OF PARENT PLANTS AND ON EMERGENCE AND OVEN-DRIED WEIGHT OF OFFSPRING*

Exposure, kR	Parents						Offspring	
	Length of primary stem		Number of pod†	Yield of beans		Emergence,‡ %	Weight,§ g	
	cm†	% of control		Weight,†	% of control			
1	66	105	89	15.0	52	92	0.068	
2	67	106	139	10.2	35	68	0.057	
3	61	97	109	0.9		72	0.033	
4	62	98	95	<0.1	<1	20	0.011	
5	49	78	62	<0.1	<1	10	0.006	
6	55	87	27					
7	50	79	7					
8	50	79	7					
9	45	71	4					
10	46	73	4					
Control	63	100	101	29.0	100	97	0.066	

*Six plants per container and one container per treatment.

†Mean per plant.

‡Number of seedlings emerged divided by number of seeds planted times 100.

§Mean oven-dried weight per seedling at 18 DAE.

variety. Even so the plants were killed by a frost prior to complete maturity; thus "yield" refers to the combined weight of pods and immature beans. Data on plant-stage sensitivity to gamma irradiation are listed in Table 4. There was a greater reduction in stem length and yield at 25 DAE than at either earlier or later times; this is not consistent with the data from the experiments with Hill soybeans. The inconsistency was probably caused by the difference in the rate of development, i.e., time in days after emergence when the various developmental stages occurred. The results shown in Fig. 1 again illustrate the stage sensitivity of the soybean plant to gamma irradiation. Yield was reduced to 50% of control by 1.3 kR at 18 DAE, by 1.75 kR at 32 DAE, and by 2.1 kR at 4 and 45 DAE.

Rice

Plants exposed to 10 to 50 kR of gamma radiation at the time of heading (64 DAE) showed marked differences for a number of end points (Table 5). Irradiation had no effect on the number of panicles per plant because the

Table 3

EFFECTS OF EXPOSURE OF HILL SOYBEAN PLANTS TO ^{60}Co GAMMA RADIATION (1 TO 10 kR AT 50 R/MIN) AT 60 DAE, i.e., LATE-BLOOMING STAGE, ON STEM LENGTH, NUMBER OF PODS, AND BEAN YIELD OF PARENT PLANTS AND ON EMERGENCE AND OVEN-DRIED WEIGHT OF OFFSPRING*

Exposure, kR	Parents					Offspring	
	Length of primary stem		Number of podst	Yield of beans		Emergence, ‡ %	Weight, § g
	cm†	% of control		Weight, † g	% of control		
1	73	116	89	20.0	69	100	0.066
2	70	111	169	18.0	62	68	0.111
3	75	119	217	16.0	55	52	0.026
4	73	116	168	6.7	23	36	0.010
5	76	121	170	5.1	18	28	0.010
6	73	116	133	< 0.1	< 1	29	0.006
7	73	116	122	< 0.1	< 1		
8	63	100	122	< 0.1	< 1		
9	77	122	123	< 0.1	< 1		
10	67	106	98	< 0.1	< 1		
Control	63	100	101	29.0	100	97	0.066

*Six plants per container and one container per treatment.

†Mean per plant.

‡Number of seedlings emerged divided by number of seeds planted times 100.

§Mean oven-dried weight per seedling at 18 DAE.

maximum number of panicles per plant had been developed before irradiation. Grain yield was reduced to approximately 50% of the control by exposures of 10 to 30 kR. It was noted also that the average oven-dried weight per grain was unaffected by the radiation exposure (data not shown). Performance of the offspring was determined by planting random samples of grain from each treatment. Emergence was unaffected by 10 kR, reduced to approximately 50% of control by 20 kR, and reduced to 0% by 40 and 50 kR. The pattern of response for seedling growth was similar to that for emergence.

Plants in the 1969 studies were exposed once in their life cycle to 25 kR at 50 R/min, and the data are shown in Table 6. The plant's stage of development at the time of irradiation influenced the response observed. Yield of grain declined sharply in plants irradiated after 10 DAE and was reduced to zero in plants exposed at 37 to 57 DAE. Plants exposed at 65 DAE yielded approximately 65% of control, which was somewhat higher than expected on the basis of results obtained the previous year (see Table 5). The performance of plants exposed at 4 and 10 DAE was influenced by radiation attenuation because their shoot meristem was below ground level.

Table 4

EFFECTS OF 2.5 kR OF ^{60}Co GAMMA RADIATION AT 50 R/MIN ON STEM LENGTH AND YIELD* OF KENT SOYBEAN PLANTS†

Time of irradiation, DAE	Length of primary stem		Yield	
	cm‡	% of control	Weight, § g	% of control
4	50	88	7.4 ± 0.8	41
12	37	65	6.7 ± 0.9	37
18	38	67	1.1 ± 0.3	6
25	35	61	0.3 ± 0.2	2
31	42	74	2.7 ± 0.4	15
37	47	83	6.8 ± 0.8	37
44	50	87	6.1 ± 0.4	34
50	54	94	14.2 ± 0.7	78
Control	57	100	18.2 ± 1.1	100

*“Yield” refers to oven-dried weight of pods and immature beans.

†Three plants per container and three containers per treatment.

‡Mean length per plant.

§ Mean per plant ± one standard error of the mean.

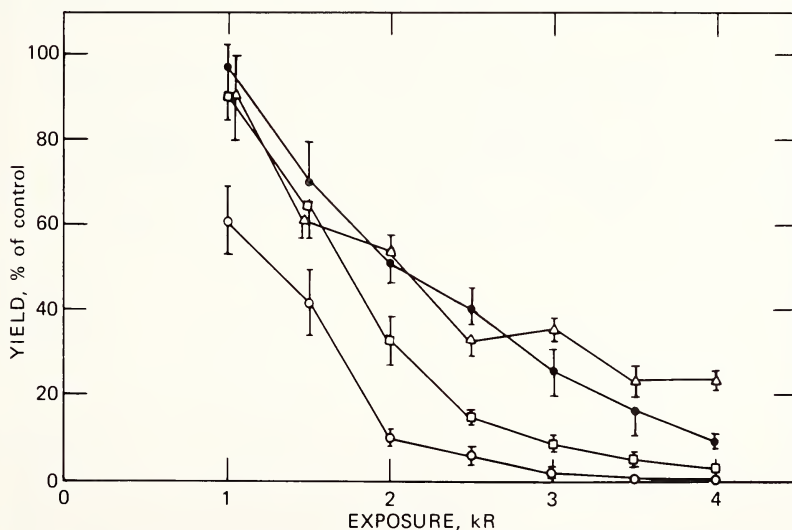

Fig. 1 Response curves for Kent soybean plants exposed to ^{60}Co gamma radiation at different days after emergence, showing the effects of from 1 to 4 kR at 50 R/min on yield. (“Yield” refers to oven-dried weight of pods and immature beans.) There were three plants per container and three containers per treatment. ●, 4 DAE; ○, 18 DAE; □, 31 DAE; △, 45 DAE; ▭, standard error.

Table 5

EFFECTS OF EXPOSURE* OF CI-8970-S RICE PLANTS TO ^{60}Co GAMMA RADIATION (10 TO 50 kR AT 50 R/MIN) AT 64 DAE, i.e., TIME OF PANICLE EMERGENCE, ON NUMBER OF PANICLES AND GRAIN YIELD OF PARENT PLANTS AND ON EMERGENCE AND WEIGHT OF OFFSPRING†

Exposure, kR	Parents		Offspring		
	Number of panicles‡	Grain yield		Emergence, § %	Weight, ¶ g
		Weight, ‡ g	% of control		
10	24	3.7	41	89	0.017
20	25	4.4	49	57	0.015
30	19	4.3	48	32	0.009
40	17	0.7	8	0	
50	20	1.9	21	0	
Control	22	9.0	100	93	0.032

*Data from the 1968 studies.

†Five plants per container and one container per treatment.

‡Mean per plant.

§ Number of seedlings emerged divided by number of seeds planted times 100.

¶Oven-dried weight per seedling at 7 DAE.

Table 6

EFFECTS OF EXPOSURE* OF CI-8970-S RICE PLANTS TO ^{60}Co GAMMA RADIATION (25 kR AT 50 R/MIN) ON GRAIN YIELD OF PARENT PLANTS AND ON EMERGENCE AND WEIGHT OF OFFSPRING†

Time of irradiation, DAE	Parents		Offspring	
	Grain yield		Emergence, § %	Weight, ¶ g
	Weight, ‡ g	% of control		
4	16.4 ± 5.7	63	92.0 ± 2.4	0.069 ± 0.005
10	11.9 ± 4.3	46	88.7 ± 2.4	0.076 ± 0.003
17	2.6 ± 0.6	10	89.1 ± 2.6	0.068 ± 0.004
24	4.0 ± 0.6	15	84.1 ± 3.1	0.072 ± 0.007
31	2.6 ± 1.1	10	82.4 ± 1.6	0.067 ± 0.005
37, 52, 57	0	0	0	
65	16.5 ± 3.6	64	74.1 ± 2.4	0.012 ± 0.050
80	37.8 ± 3.5	146	59.5 ± 3.1	0.009 ± 0.001
Control	25.9 ± 9.1	100	91.6 ± 0.7	0.070 ± 0.005

*Data from the 1969 studies.

†Four plants per container and three containers per treatment.

‡Mean per plant ± one standard error.

§ Mean of four replications ± one standard error; 60 seeds planted per replication.

¶Mean fresh weight per survivor at 8 DAE ± one standard error.

Emergence and fresh weight of the offspring were unaffected when the parent plants were exposed to 25 kR at 50 R/min before fertilization and embryogenesis. In contrast, at 65 and 80 DAE emergence and fresh weight per seedling decreased significantly.

Exposure-response curves for plants at 2, 31, and 65 DAE are shown in Fig. 2. The 2-DAE plants were irradiated in small peat pots, and the shoot meristem of 31- and 65-DAE plants was above ground level; therefore radiation

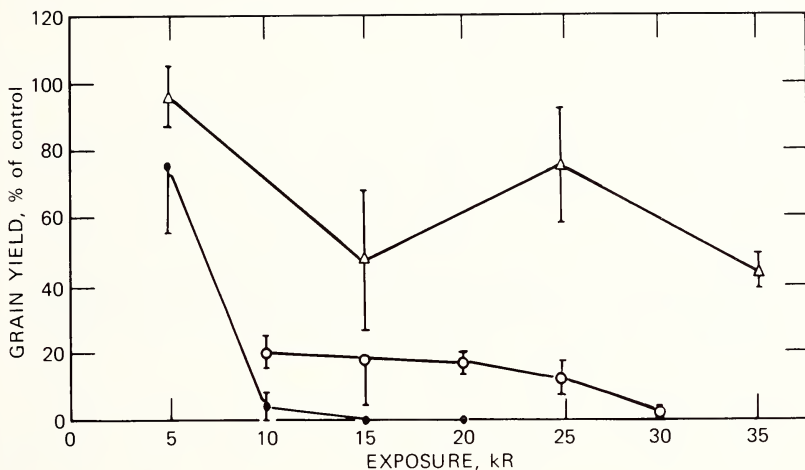

Fig. 2 Response curves for CI-8970-S rice plants exposed to ^{60}Co gamma radiation at different days after emergence, showing the effects of from 5 to 35 kR at 50 R/min on grain yield. The 2-DAE plants were growing in small peat pots, and the 31- and 65-DAE plants had their shoot meristem above the surface of the medium; therefore radiation attenuation was minimal in all cases. There were four plants per container and three containers per treatment. ●, 2 DAE; ○, 31 DAE; △, 65 DAE; \pm , standard error.

attenuation was minimal in all cases. An exposure of 10 kR reduced yield of grain in 2- and 31-DAE plants to such an extent that it would have been impractical to harvest the crop. The 65-DAE plants showed a higher tolerance to gamma radiation than did the 2- and 31-DAE plants. However, the extent of variability was high for those plants, and the only conclusion one can make is that 5 kR did not reduce yield of grain, whereas 15, 25, and 35 kR caused a significant reduction. The emergence and oven-dried weight of offspring from parent plants irradiated at 2, 31, and 65 DAE are shown in Figs. 3 and 4, respectively. Emergence was unaffected when the parent plants were exposed to either 5 and 10 kR at 2 DAE or 5 to 30 kR at 31 DAE; however, emergence decreased steadily as exposure increased when the parent plants were irradiated at 65 DAE. The D_{50} for emergence of offspring was approximately 10 kR, and

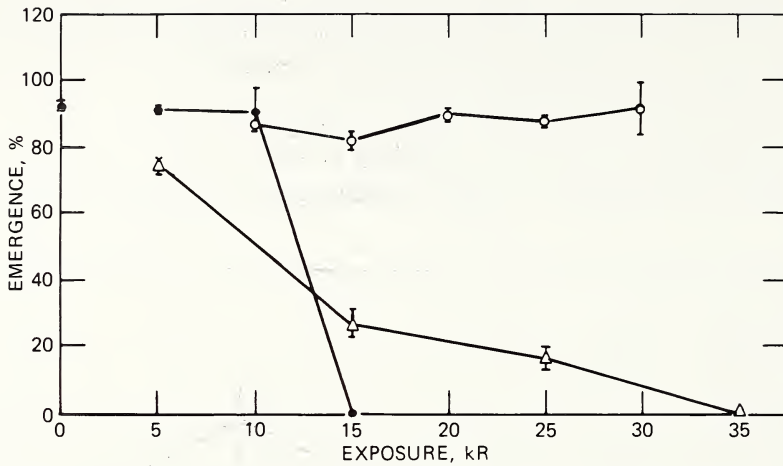

Fig. 3 Response curves for CI-8970-S rice plants exposed to ^{60}Co gamma radiation at different days after emergence, showing the effects of from 5 to 35 kR at 50 R/min to parent plants on percent emergence of their offspring. Sixty seeds were planted for each of four replications in a randomized block design. ●, 2 DAE; ○, 31 DAE; △, 65 DAE; $\bar{\pm}$, standard error.

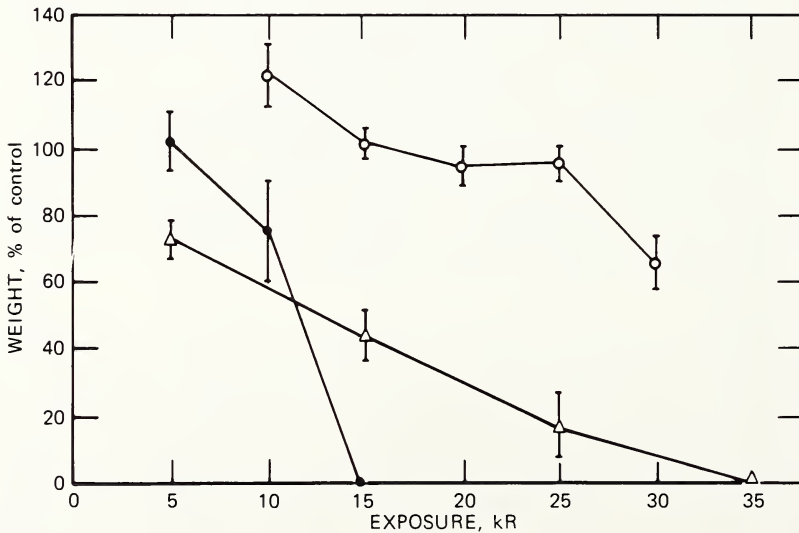

Fig. 4 Response curves for CI-8970-S rice plants exposed to ^{60}Co gamma radiation at different days after emergence, showing the effects of from 5 to 35 kR at 50 R/min to parent plants on oven-dried weight of their offspring at 7 DAE. Sixty seeds were planted for each of four replications, and the average weight per survivor is presented as percent of control. ●, 2 DAE; ○, 31 DAE; △, 65 DAE; $\bar{\pm}$, standard error.

there was no emergence at 35 kR when the parent plants were irradiated at 65 DAE. Dry weight of the offspring from parent plants irradiated at 2 DAE decreased to approximately 75% of control at 10 kR, the highest exposure at which viable grains were harvested. Dry weight of the offspring from parent plants irradiated at 31 DAE decreased to approximately 65% of control at 30 kR, the highest exposure used. Dry weight of the offspring of parent plants irradiated at 65 DAE showed a linear decrease vs. exposure; at 25 kR their performance was approximately 20% of control, whereas at 35 kR there was no emergence. The D_{50} was approximately 12.5 kR.

Corn

The effect of stage of development on the yield of grain of WF-9 × 38-11 corn plants exposed to 2.5 kR at 50 R/min is shown in Fig. 5. Results from studies conducted in 1968 and 1969 indicated little or no difference attributable to year effects. An exposure of 2.5 kR caused an increasing reduction in grain yield as the plant progressed through the early stages of vegetative development.

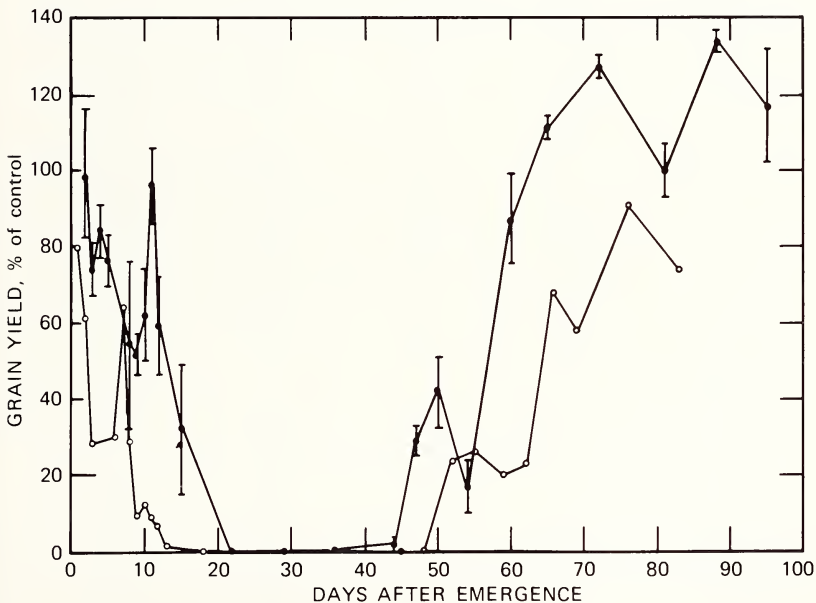

Fig. 5 Response curves for WF-9 × 38-11 corn plants exposed to ^{60}Co gamma radiation at different days after emergence, showing the effects of 2.5 kR at 50 R/min on the grain yield per plant. In the 1968 studies there were two plants per container and three containers per treatment; in 1969 there were three plants per container and three containers per treatment. The time of tassel initiation was 22 and 19 DAE, top ear initiation was 32 and 30 DAE, and silking was 55 and 49 DAE in 1968 and 1969, respectively. ○, 1968; ●, 1969; \pm , standard error.

Radiation attenuation may have caused the observed response because the shoot meristem of the corn plant became progressively closer to the soil surface during this period. Yield of grain decreased to zero following 2.5 kR to plants irradiated from the time of transition of the shoot apex from the vegetative to the reproductive phase through the initiation and development of ear and tassel primordia. The generally increased yield of grain of plants irradiated at later successive stages after fertilization reflects the increasing tolerance of the developing embryo. Data on the response of the various morphological end points that contribute to yield of grain are listed in Table 7, and in general, their

Table 7
EFFECTS OF EXPOSURE* OF WF-9 × 38-11 CORN PLANTS TO ^{60}Co
GAMMA RADIATION (2.5 kR AT 50 R/MIN) ON VARIOUS
MORPHOLOGICAL END POINTS CONTRIBUTING TO GRAIN YIELD†

Time of irradiation, DAE	Ear length, ‡ cm	Seeded ear length, ‡ cm	Number of kernels per ear ‡	Kernel weight, § g
1	19.0	16.7	416	0.26
2	16.6	13.7	313	0.25
3	16.7	13.0	130	0.27
6	15.8	12.1	92	0.29
7	17.0	14.1	330	0.25
8	11.4	9.9	132	0.24
9	13.2	11.4	72	0.14
10	14.0	12.0	106	0.13
13	14.0	7.5	103	0.10
14	15.6	8.6	73	0.10
15	11.0	4.5	30	0.07
20	8.5	7.0	33	0.08
27-48¶				
52	13.1	11.5	246	0.16
55	14.3	12.0	273	0.13
59	18.1	15.3	368	0.08
62	17.2	13.7	360	0.09
66	19.6	16.1	545	0.18
69	20.3	15.5	391	0.24
76	21.0	17.1	552	0.26
83	19.1	17.0	476	0.24
Control	20.9	18.6	616	0.25

*Data from the 1968 studies.

†Two plants per container and three containers per treatment.

‡Mean per ear.

§ Mean per kernel.

¶No grain yield for six dates of irradiation.

responses are similar to that for grain yield. Table 8 lists the various recognizable morphological events in the plant's life cycle as they occurred vs. days after emergence.

The relatively high yield of grain observed when 7- and 10-DAE plants were irradiated in 1968 and 1969, respectively, probably reflects a radiation-tolerant stage of development, namely, initiation and development of primary axillary buds or suckers. Some irradiated plants developed as many as three primary suckers that produced ears and a measurable amount of grain. Likewise, the relatively high yield of grain observed in 55- and 48-DAE plants irradiated in

Table 8
PROGRESSIVE MORPHOLOGICAL DEVELOPMENT OF CONTROL
WF-9 × 38-11 CORN PLANTS*

Event	Days after emergence	
	1968	1969
Accelerated growth in upstretched leaf height	1 to 55	1 to 49
Tassel initiation	22	19
Terminal shoot growing point at soil surface	23	19
Accelerated stem elongation	31 to 55	21 to 55
Ear 1 (top ear) initiation	32	30
Ear 2 initiation	33	32
Accelerated tassel elongation	34 to 44	29 to 43
Full potential of kernel primordia established, ear 1	44	
Total blade length achieved	45	
Accelerated tassel peduncle elongation	48 to 55	40 to 51
Accelerated ear 1 elongation	48 to 62	40 to 58
Tassel emergence	52	43
Anthesis	55	50
Very early silking	55	49

*Data were collected by dissecting control plants grown concurrently with other plants that were irradiated at different days after emergence.

1968 and 1969, respectively, probably reflects a stage of relative tolerance to gamma rays. Megagametogenesis had occurred by this time, and the egg was mature. Microgametogenesis had also occurred; however, we have no means of evaluating the effects of irradiation on pollen, because pollen from control plants was available for pollination.

To test the sensitivity of WF-9 × 38-11 corn plants to gamma radiation without the complication of radiation attenuation, we irradiated plants in small peat pots and then transplanted them to containers. The results are shown in Fig. 6. Yield of grain showed a linear decrease with exposure and was reduced to zero at 2.5 kR. The D_{50} for yield of grain was approximately 750 R. This

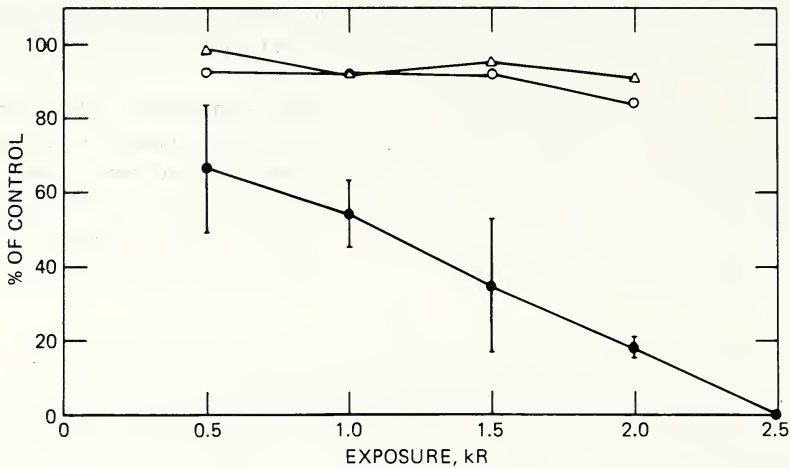

Fig. 6 WF-9 \times 38-11 corn plants exposed to ^{60}Co gamma radiation at 1 DAE in small peat pots; radiation attenuation at the shoot meristem was minimal. The response curves show the effect of 0.5 to 2.5 kR at 50 R/min on grain yield of the parent plants and emergence and weight of their offspring. Data are from the 1969 studies. ●, yield; ○, fresh weight of offspring at 13 DAE; △, emergence; \pm , standard error.

indicates that the decrease in tolerance in plants irradiated during their early seedling stage (Fig. 5) was probably caused by radiation attenuation by the medium. Emergence and fresh weight of the offspring of parent plants irradiated at 1 DAE showed little or no difference as exposure was increased to 2 kR.

An exposure response study was conducted with WF-9 \times 38-11 corn plants at 10 selected times after emergence. Response data are listed in Table 9; the pattern of response for stage of development was similar to that shown in Fig. 5. Plants irradiated at 22 and 36 DAE showed the highest degree of sensitivity; zero yield of grain was observed following exposures of 1.5 and 2 kR, respectively. Yield of grain showed an increased tolerance to gamma radiation when plants were exposed to 1.5 kR or more at 44 and 50 DAE. Plants exposed at 54 DAE, the zygotic and early embryonic stages, showed a relatively high sensitivity, which decreased with each later successive time of irradiation.

The performance of offspring from grain harvested from irradiated parent plants was studied under greenhouse conditions. Response curves in Fig. 7 show the effects of stage of development at irradiation on the emergence and fresh weight of offspring from parent plants receiving 2.5 kR at 50 R/min. The response for both of these end points was similar to that for yield of grain for the irradiated parent plants. The increase in tolerance of the developing embryo is evident from 60 to 95 DAE. Data on the emergence and fresh weight of offspring from the exposure-response study are shown in Tables 10 and 11,

Table 9

EFFECTS OF EXPOSURE* OF WF-9 x 38-11 CORN PLANTS TO ^{60}Co GAMMA RADIATION (1 TO 2.5 kR AT 50 R/MIN) ON GRAIN YIELD†

Time of irradiation, DAE	Yield weight‡ at four exposures, g			
	1.0 kR	1.5 kR	2.0 kR	2.5 kR
8	121 ± 8	83 ± 2	68 ± 17	51 ± 21
22	61 ± 11	0	0	0
36	57 ± 17	14 ± 9	0	0
44	57 ± 25	42 ± 1	18 ± 8	2 ± 2
50	81 ± 4	87 ± 14	63 ± 2	40 ± 9
54	89 ± 11	44 ± 9	26 ± 9	17 ± 7
60	50 ± 49	106 ± 5	68 ± 2	83 ± 12
65	84 ± 16	103 ± 11	88 ± 4	106 ± 3
72	100 ± 24	115 ± 4	107 ± 8	121 ± 3
81	115 ± 4	110 ± 20	113 ± 14	95 ± 7
Control	95 ± 19			

*Data from the 1969 studies.

†Three plants per container and three containers at 2.5 kR and two containers for other exposures.

‡Mean per plant ± standard error.

respectively. Generally, emergence showed a relatively high tolerance to gamma radiation, and fresh weight showed a pattern of response similar to the yield of grain. The increase in fresh weight of the offspring from parent plants irradiated at 60 to 81 DAE shows the decrease in sensitivity of the developing embryo.

DISCUSSION

Irradiation can reduce the vegetative mass of the plant, the photosynthetic factory, and in so doing can reduce the carbohydrate supply available for storage in seeds. Soybean plants exposed to 2.5 kR produced fewer primary stem internodes and leaves and fewer and shorter branches. Some leaflets were reduced in size. Branches abscised before and after flowering and fruiting, and either seed potential or seed was lost. Rice plants irradiated at 2 DAE in small peat pots at 5 kR showed significantly less height and tillering than control plants 4 weeks later. Corn plants irradiated at 1 DAE in small peat pots showed a reduction in size following exposure to 500 R or more gamma radiation after 15 days. Specific irradiation effects observed in experiments included shortened internodes, shortened and decreased width of leaf blades, and shortened leaf sheaths. Others have shown that irradiation can reduce vegetative mass; e.g., the rice studies of Kawai and Inoshita⁴ and the barley studies of Hermelin.⁵

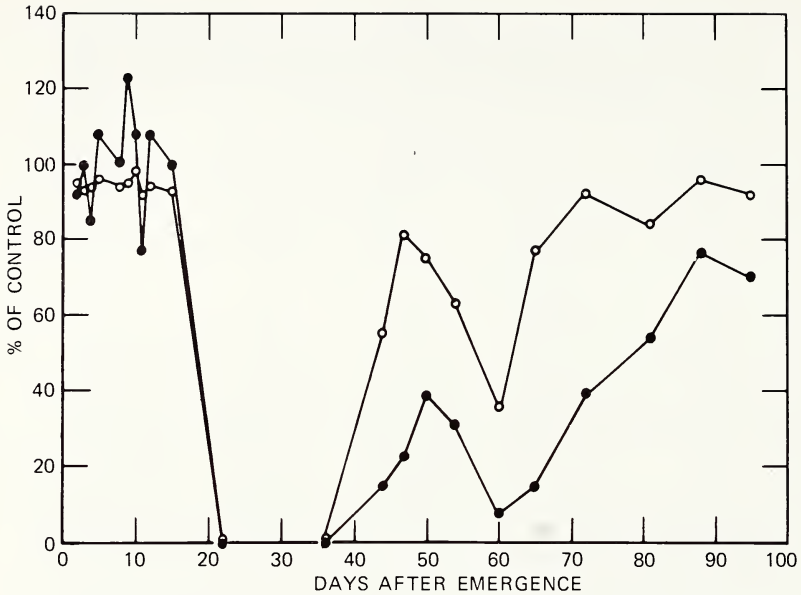

Fig. 7 Response curves for WF-9 x 38-11 corn plants exposed to ^{60}Co gamma radiation at different days after emergence, showing the effects of 2.5 kR at 50 R/min to the parent plants on emergence and fresh weight of their offspring. Data are from the 1969 studies. ○, emergence; ●, fresh weight of offspring at 13 DAE.

Irradiation can alter the normal developmental pattern of a plant or the timing of developmental events and thus can reduce grain yield. Corn has been bred and selected for maximum yield obtained from one or at most two ears on a single-stemmed plant. The 2.5-kR exposures increasingly inhibited parental shoot development in corn as irradiation took place later after shoot emergence. This inhibition pattern was attributed to increased irradiation of the apical meristem of the parental shoot as the underground stem elongated. Increasing inhibition of the parental shoot permitted development of axillary shoots until as many as three suckers developed. However, all this vegetative proliferation cost time and available carbohydrates, and grain yield declined sharply with sucker proliferation. When parental shoots were irradiated later, the sucker buds did not develop, and the plant died. Sucker proliferation has been reported by others, including Sparrow and Puglielli¹ for corn and Davies² for wheat.

Although the early developmental period of corn, rice, and possibly of any grass plant, is characterized by a decline in yield as irradiation is delayed, there is a period of relative tolerance to gamma irradiation. This is caused probably by the arrest of the primary shoot meristem which permits the development of one or more axillary buds that are more tolerant to gamma irradiation because of their developmental stage.

Table 10

EFFECTS OF EXPOSURE OF PARENT WF-9 x 38-11 CORN PLANTS TO ^{60}Co GAMMA RADIATION (1 TO 2.5 kR AT 50 R/MIN) ON THE EMERGENCE OF OFFSPRING*

Time of irradiation, DAE	Emergence† at four exposures, % of control			
	1.0 kR	1.5 kR	2.0 kR	2.5 kR
8	97	94	98	94
22	96	‡	‡	‡
36	91	61	‡	‡
44	94	86	86	55
50	79	84	82	75
54	78	55	72	63
60	78	89	69	36
65	97	98	85	77
72	98	97	97	92
81	94	98	97	84

Control, 100%

*Sixty seeds planted for each of three replications.

†Mean of three replications.

‡No seed produced by parent plants.

Table 11

EFFECTS OF EXPOSURE* OF PARENT WF-9 x 38-11 CORN PLANTS TO ^{60}Co GAMMA RADIATION (1 TO 2.5 kR AT 50 R/MIN) ON FRESH WEIGHT OF OFFSPRING HARVESTED AT 13 DAE

Time of irradiation, DAE	Fresh weight† at four exposures, % of control			
	1.0 kR	1.5 kR	2.0 kR	2.5 kR
8	108	108	100	100
22	130	‡	‡	‡
36	77	38	‡	‡
44	85	69	69	15
50	54	69	46	35
54	54	31	39	31
60	62	46	23	8
65	85	77	39	15
72	77	69	54	39
81	85	77	62	54

Control, 1.3 g = 100%

*Data from the 1969 studies.

†Mean of three replications.

‡No seed produced by parent plants.

Irradiation can affect gametogenesis, the production of a functional egg and pollen. Hermelin⁵ found that barley is sensitive to irradiation at meiosis, and Kawai and Inoshita⁴ found the same for rice. The exposure of soybeans to 2.5 kR at early bloom caused severe yield reduction. The exposures of rice plants to 25 kR between 34 and 55 DAE (roughly from panicle initiation to anthesis) eliminated all grain yield. One-tenth this exposure (2.5 kR) applied to corn between tassel initiation and a week before silking also eliminated grain yield. Corn plants exposed at about the time of ear initiation (32 DAE) died. The adaptive nature of the corn plant when irradiated at this time became apparent in that tiller buds among brace roots became floral and a small amount of grain was produced before complete plant death. This grain would not be harvestable, however. Corn has the capacity to form ears from the top ear downward. Since each lower ear is initiated slightly after the one above it, one might expect that the second or third ear would take over development when the top ear is damaged. This sometimes happens when top ears are bagged to prevent premature fertilization in a breeding program but was not observed in our experiments. Either all axillary buds were damaged similarly or the effects of death in the top ear unfavorably permeated to lower ones. Plants killed by irradiation died from the top downward, and death was preceded by an accumulation of anthocyanin in the leaf tissue.

Also, the normal corn ear is terminal; i.e., it arises on the end of the shank and is enclosed by husk leaves. Axillary ear buds frequently are initiated late in development above husk leaves, and, when the terminal ear is irradiated before silking, an axillary ear may eventually produce grain.

A radioresistant stage for corn apparently exists just before silking. Plants irradiated at 2.5 kR within a week before the first emergence of silks produced relatively high grain yields; the grain had relatively high germination and produced relatively vigorous seedlings. This phenomenon is believed to be caused by the egg's having achieved full development in preparation for silk elongation, pollination, and fertilization. This potential to form grain might not be achieved in a uniform corn field where most top ears would be in a comparable developmental state and where irradiation eliminated viable pollen. Our material had viable pollen available for fertilization. Donini and Hussain⁶ found that irradiation was more detrimental to pollen formation than to egg formation in wheat. This needs to be investigated in corn.

Gametogenesis and the flowering date of a plant can be advanced by irradiation.⁷ We observed this when 1-DAE corn plants were exposed to 4.5 kR (data not presented). In our material, however, this occurred at the expense of building vegetative structure, and grain yield was reduced. When tiller proliferation was encouraged by an irradiation insult to the parent shoot, the end result was late and incomplete ear formation. Upsetting the normal plant anthesis and silking pattern can reduce yields since pollen is not available when silks are receptive.

Irradiation can reduce grain yield by direct effects on the zygote, later embryonic plant development, and endosperm development. Mericle and Mericle⁸ found the zygote stage in barley to be especially sensitive. The sharp reduction in our corn yields immediately after first silking supports this conclusion.

ACKNOWLEDGMENTS

The UT-AEC Agricultural Research Laboratory is operated by the Tennessee Agricultural Experiment Station for the U. S. Atomic Energy Commission under Contract AT-40-1-GEN-242.

This work was funded by the Office of Civil Defense, Work Order No. DAHC 20-69-C-0109 and is published with the permission of the Dean of the University of Tennessee Agricultural Experiment Station, Knoxville.

REFERENCES

1. A. H. Sparrow and Leanne Puglielli, Effects of Simulated Radioactive Fallout Decay on Growth and Yield of Cabbage, Maize, Peas, and Radish, *Radiat. Bot.*, **9**: 77-92 (1969).
2. C. R. Davies, Effects of Gamma Irradiation on Growth and Yield of Agricultural Crops. I. Spring Sown Wheat, *Radiat. Bot.*, **8**: 17-30 (1968).
3. M. C. Bell and C. V. Cole, Vulnerability of Food Crop and Livestock Production to Fallout Radiation. Final Report, USAEC Report TID-24459, UT-AEC Agricultural Research Laboratory, Sept. 7, 1967.
4. T. Kawai and T. Inoshita, Effects of Gamma Irradiation on Growing Rice Plants. I. Irradiation at Four Main Developmental Stages, *Radiat. Bot.*, **5**: 233-255 (1965).
5. T. Hermelin, Effects of Acute Gamma Irradiation in Barley at Different Ontogenetic Stages, *Hereditas*, **57**: 297-302 (1967).
6. B. Donini and S. Hussain, Development of Embryo of *Triticum durum* Following Irradiation of Male or Female Gamete, *Radiat. Bot.*, **8**: 289-295 (1968).
7. K. Sax, The Stimulation of Plant Growth by Ionizing Radiation, *Radiat. Bot.*, **3**: 179-186 (1963).
8. L. W. Mericle and R. P. Mericle, Radiosensitivity of the Developing Plant Embryo, in Fundamental Aspects of Radiosensitivity. Report of a Symposium Held June 5-7, 1961, Upton, N. Y., USAEC Report BNL-675, pp. 262-286, Brookhaven National Laboratory. (Brookhaven Symposia in Biology Number 14.)

EFFECTS OF EXPOSURE TIME AND RATE ON THE SURVIVAL AND YIELD OF LETTUCE, BARLEY, AND WHEAT

P. J. BOTTINO and A. H. SPARROW
Brookhaven National Laboratory, Upton, New York

ABSTRACT

Experiments were conducted to compare the effects of ^{137}Cs gamma radiation given as either 1-, 4-, 8-, or 16-hr treatments at constant rates (CR) with 36-hr fallout-decay-simulation (FDS) or with buildup (Bu) and fallout-decay-simulation (Bu + FDS) treatments with variable exposure rates. Seedlings of lettuce were given Bu + FDS, FDS, and 1-, 4-, 8-, and 16-hr CR treatments. Barley and wheat seedlings were given FDS and 8- and 16-hr CR treatments. Following irradiation the lettuce plants were transplanted to the field, barley to the greenhouse, and wheat to a growth chamber. The criteria of effect used were survival and yield. Young barley seedlings were given a total exposure of 1600 R at 32 different rates ranging from 60 to 4800 R/hr. The first leaf of each seedling was measured after 8 days of growth.

For equal total exposures, FDS treatments were more effective than 16-hr CR treatments in reducing survival and yield of all three crops. The ratio of 16-hr CR to FDS at LD_{50} was 1.43 for lettuce, 1.23 for barley, and 1.37 for wheat. For yield the FDS was more effective only at exposures above the LD_{50} . Lettuce survival increased with exposure time between 1 and 16 hr, but this was a linear increase only after 4 hr. Barley seedling height decreased as the exposure rate increased from 60 to about 1000 R/hr. Further increases in exposure rate above 1000 R/hr had no further effect on seedling height. The greater effectiveness of the high exposure rates observed in these experiments substantiates our conclusion that the increased effect of an FDS treatment compared with a 16-hr CR treatment is attributable to the high initial exposure rates of FDS.

Similar results for survival and yield reduction for the 8-hr CR and the FDS treatments were observed. Hence investigators lacking the facilities to simulate fallout decay could use an 8-hr CR treatment to approximate the effects of simulated-fallout-decay treatments.

For equal total exposures of gamma radiation, a treatment simulating fallout decay has been reported¹⁻³ to be more effective in reducing survival and yield of crop plants than are prolonged constant-exposure-rate treatments. The greater effectiveness of the fallout-decay-simulation (FDS) treatment is thought to be due to the very high exposure rates encountered initially.¹⁻³ Thus study of the

effects of a given amount of fallout or simulated fallout radiation seems to become basically a problem of the effect of variations in exposure rate. This paper presents some of our most recent data on the effects of the gamma component of simulated fallout on crop plants and additional data showing how variations in exposure rate can affect a plant's response to radiation. These data give support to the conclusion that high exposure rates are the basis for the greater effectiveness of the fallout-decay treatments. The plants used in this study were lettuce, barley, and wheat.

MATERIALS AND METHODS

Facilities and Treatment Procedure

The theory and facilities used to simulate fallout decay have been previously described in detail.¹ Basically, a series of stainless-steel shields are lowered over a 12,000-Ci ^{137}Cs source at predetermined times to simulate exposure to fallout radiation that decays according to the $t^{-1.2}$ law. Each shield is machined to reduce the intensity by one-half. The plants are placed in concentric arcs around the source, and an entire series of exposures is given at one time for either FDS or constant-rate (CR) exposures.

Figure 1 shows the exposure-rate patterns for a total exposure of 5000 R for the treatments used in this study. The CR treatments simply extend for a specific time—in the present study this was for 1, 4, 8, or 16 hr. In the buildup and fallout-decay-simulation treatment (Bu + FDS), which is a close approximation to a true fallout situation, the exposure rate starts out at a low level, builds up in 51 min to a peak, and then decreases in a stepwise pattern over the exposure period. In the FDS treatment the exposure rate starts out very high and decreases in a similar stepwise fashion. The steps on the buildup and decay curves represent shields being raised or lowered, and, although this is a stepwise relation, the curve for accumulating exposure is fairly smooth, as shown in Fig. 2.

Experimental Procedure

In the first experiment seedlings of lettuce, *Lactuca sativa* 'Summer Bibb,' were exposed 26 days after sowing in 2-in. peat pots to the following treatments: (1) CR treatments for 1, 4, 8, or 16 hr or (2) changing-exposure-rate treatments given as either FDS or Bu + FDS for 36 hr. Fifteen exposures of 30 plants each, plus a nonirradiated control, were used for the 16-hr CR, FDS, and Bu + FDS treatments, and seven exposures of 10 plants each, plus a nonirradiated control, were used for the 1-, 4-, and 8-hr CR treatments. The experiment was carried out in early June 1969. The exposure rates for a total exposure of 5000 R were 5000, 1250, 625, and 312.5 R/hr for the 1-, 4-, 8-, and 16-hr treatments, respectively. The exposure rates for other total exposures

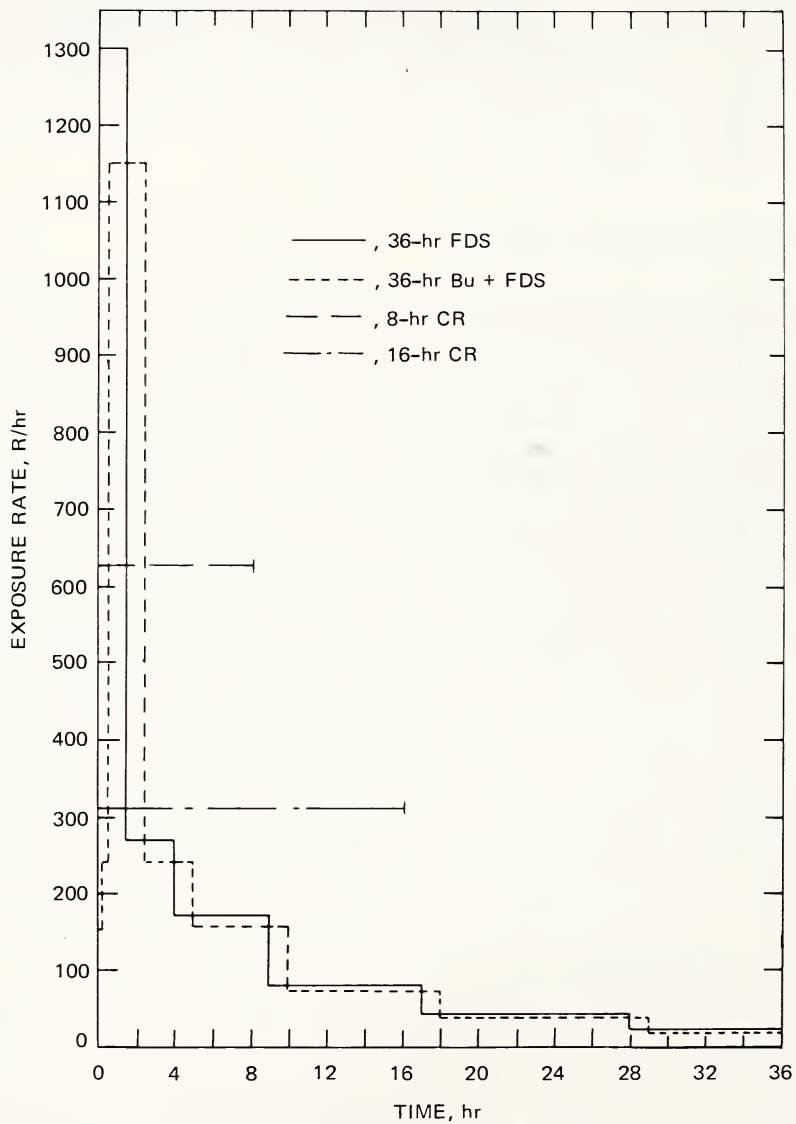

Fig. 1 Exposure-rate patterns for a total exposure of 5000 R for the treatments used.

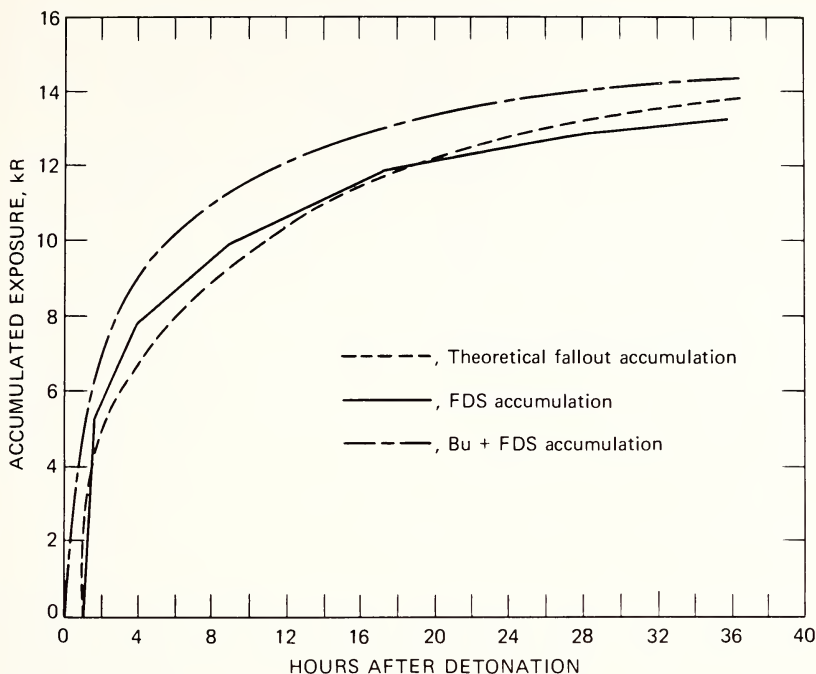

Fig. 2 Accumulated exposures for the 36-hr FDS and 36-hr Bu + FDS at 1 m from the source compared with the theoretical accumulated exposures expected during the same period from decay according to the $t^{-1.2}$ law.

varied in proportion to the exposure time. After irradiation the plants were transplanted to the field. Survival data were collected every other day until no more deaths attributable to the radiation occurred. Yield data measured as fresh weight of the aboveground portion of each plant were collected at the conclusion of the experiment.

In December 1969 seedlings of barley, *Hordeum vulgare* 'Mari,' 8 days after sowing in 2-in. peat pots, were irradiated with the following treatments: (1) CR treatments for either 8 or 16 hr or (2) a changing-exposure-rate treatment given as a 36-hr FDS. For each treatment there were 14 exposures of 10 plants each, plus a nonirradiated control. After irradiation the plants were transplanted into 6-in. clay pots and moved to a heated greenhouse. Survival data were collected three times a week until no more deaths attributable to the radiation occurred. At the conclusion of the experiment, the seed was harvested and weighed.

In February 1970 a similar experiment using the same treatments as used for barley was carried out with hard red spring wheat, *Triticum aestivum* 'Indus.' There were nine exposures of 10 plants each, plus a nonirradiated control for each treatment. The plants were transplanted into 4-in. clay pots and placed in a light- and temperature-controlled growth room. The light was cool white

fluorescent and supplemental incandescent (approximately 1600 ft-c) on an 18-hr day, and the temperature was $68 \pm 2^\circ\text{F}$ at night and $72 \pm 2^\circ\text{F}$ during the day. Again survival data were collected three times a week, and the seed was collected and weighed at the end of the experiment.

An experiment to study the effect of exposure rate was conducted with germinating seeds of barley, *Hordeum vulgare* 'Himalaya.' Dry seeds (approximately 12% water content) were planted on blotters according to the method of Myhill and Konzak.⁴ Irradiation began 24 hr after planting and the seeds were given an exposure of 1600 R delivered at 32 exposure rates ranging from 60 to 4800 R/hr for periods ranging from 26.6 hr to 19.8 min. Forty seedlings per exposure-rate treatment were used. After irradiation the seedlings were returned to a growth chamber and grown at 80°F under continuous fluorescent light. A constant high humidity was maintained in the chamber by bubbling air through a water reservoir. The height of the first leaf was measured 8 days after irradiation.

RESULTS

The results of the lettuce experiment are given in Fig. 3. The survival data (Fig. 3a) are shown on a probit plot of survival as percent of control against exposure for the three treatments. The graph shows the computer-fitted lines and actual data points. No difference was found between the Bu + FDS and the FDS treatments. Both treatments were more effective in reducing survival than the 16-hr CR treatment. The LD_{50} values for the three treatments were 4.79 ± 0.10 kR for FDS, 4.97 ± 0.12 kR for Bu + FDS, and 7.01 ± 0.12 kR for the 16-hr CR.

The yield data (Fig. 3b) show very little difference between the three treatments at the low exposures. At the higher exposures there was no difference between the results of the Bu + FDS and FDS treatments, but both were clearly more effective in reducing yield than the 16-hr CR treatment. A considerable amount of growth stimulation was evident at the lower exposures for all three treatments. This was found to be caused by the increased production of axillary growth, which contributed to the augmented fresh weight of the plant.

The survival results for the lettuce CR treatments are compared in Table 1. As the exposure time increased, the exposure required to produce the three given end points also increased. The nature of this relation is shown for the LD_{50} values in Fig. 4, where LD_{50} is plotted against the log of exposure time. There is little change in LD_{50} for the 1- and 2-hr treatments. As the exposure time is increased, however, LD_{50} increases almost with the square of the exposure time.

The results from the barley experiment are shown in Figs. 5 and 6. Figure 5 shows the probit plot of survival against exposure for the FDS and 16-hr CR treatments. The data are somewhat variable because only 10 plants per exposure

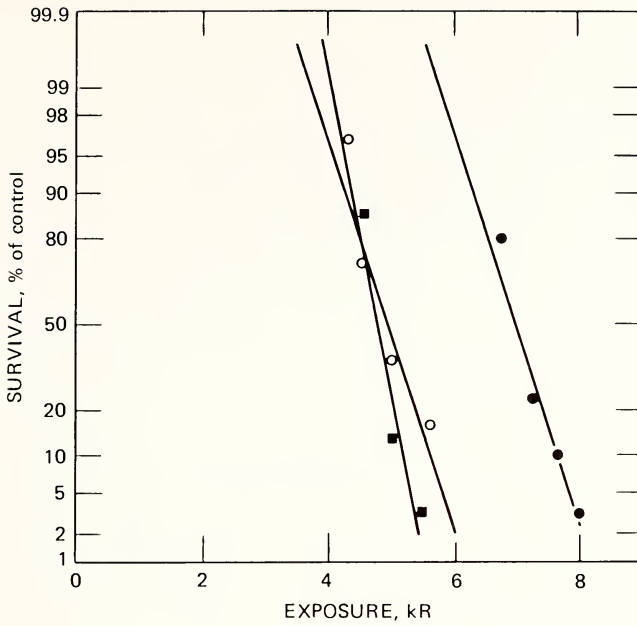

(a)

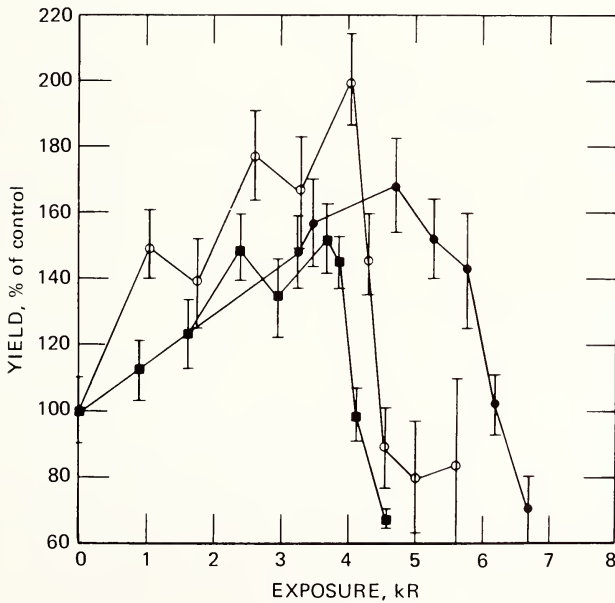

(b)

Fig. 3 (a) Probit plot of survival as percent of control vs. exposure for lettuce given 16-hr CR (●) and 36-hr FDS (■) and Bu + FDS (○) treatments. (b) Mean weight per treated plant as percent of control vs. exposure for lettuce for the same three treatments. $\bar{\pm}$ indicates \pm standard deviation (Ref. 2).

Table 1
COMPARISON OF THE SURVIVAL END POINTS FOR
1-, 4-, 8-, AND 16-HR CR TREATMENTS FOR LETTUCE

	1-hr CR, kR \pm S.D.*	4-hr CR, kR \pm S.D.	8-hr CR, kR \pm S.D.	16-hr CR, kR \pm S.D.
LD ₁₀	2.35 \pm 0.06	3.03 \pm 0.15	4.59 \pm 0.11	6.39 \pm 0.11
LD ₅₀	2.57 \pm 0.06	3.47 \pm 0.10	5.03 \pm 0.07	7.01 \pm 0.07
LD ₉₀	2.78 \pm 0.08	3.90 \pm 0.12	5.46 \pm 0.13	7.64 \pm 0.10

*The abbreviation S.D. is standard deviation.

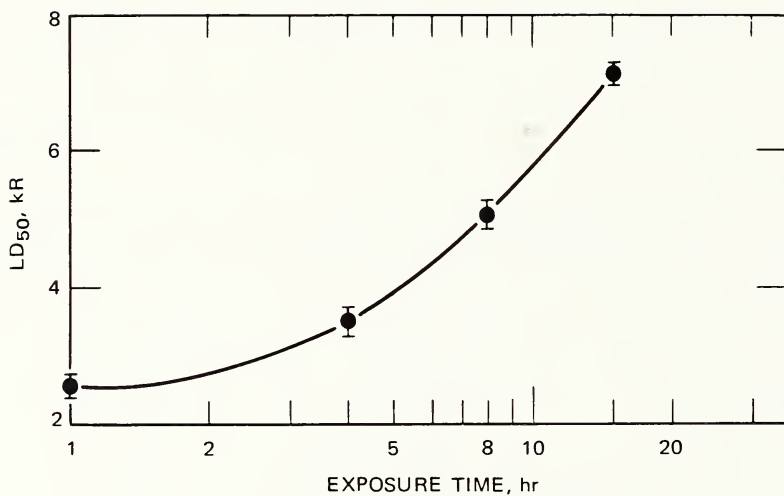

Fig. 4 LD₅₀ vs. log of exposure time for lettuce irradiated for 1, 4, 8, and 16 hr at constant rates. \pm indicates \pm standard deviation.

were used, but the results are consistent with those for the other species in showing the FDS treatment to be more effective in reducing survival than the 16-hr CR treatment. The yield data (Fig. 6) resemble the lettuce data (Fig. 3b) in that there is little difference between the FDS and 16-hr CR treatments at the lower exposures, but at exposures of 4 kR or more the CR treatment is clearly less effective in reducing yield. The 16-hr CR values are consistently above the FDS values although they are not always significantly different from them. Representative plants from the surviving exposures of the three treatments are shown in Fig. 7.

The probit plot of survival for wheat against exposure is given in Fig. 8, and again the FDS treatment was more effective in reducing survival than the 16-hr CR treatment. The yield data (Fig. 9) are similar to those for lettuce and barley

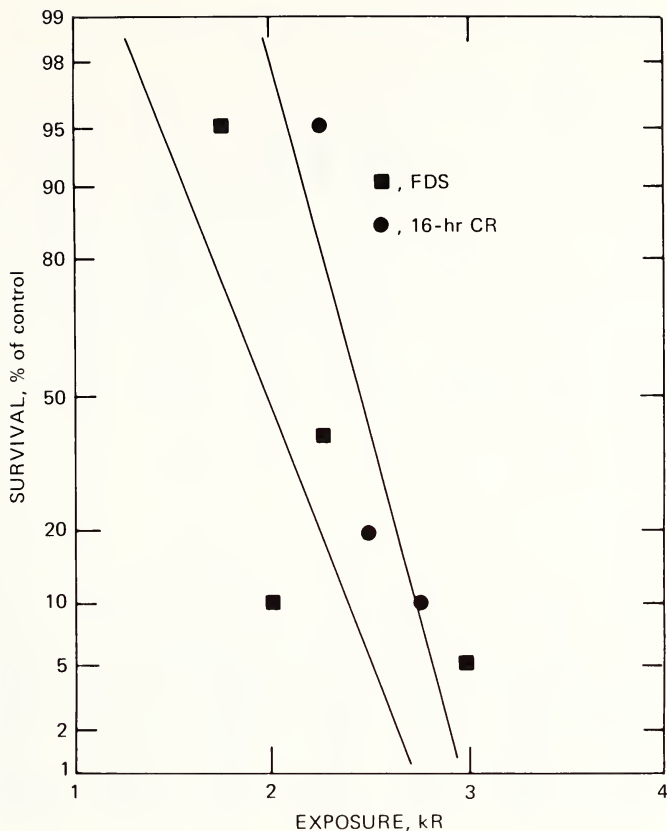

Fig. 5 Probit plot of survival as percent of control vs. exposure for barley given 36-hr FDS and 16-hr CR treatments.

in that the FDS treatment is more effective in reducing yield than the 16-hr CR treatment at the high exposures only. Representative plants of the surviving exposures from all treatments are shown in Fig. 10.

It became clear that a close relation might exist between the effects produced by 8-hr CR treatments and 36-hr FDS treatments. Therefore a comparison between these two treatments for both survival and yield was made for all three crops. This comparison is given for survival in Table 2 and Fig. 11 and for yield in Figs. 12 to 14. The effects of these two treatments are essentially the same, especially at the LD_{50} . Table 2 shows that the LD_{50} values for each crop were not significantly different at the 5% level. The situation is comparable when yield is the criterion of effect studied (Figs. 12 to 14).

The results of the barley exposure-rate experiment are given in Fig. 15. The injury increased in proportion to the log of exposure rate between 60 and

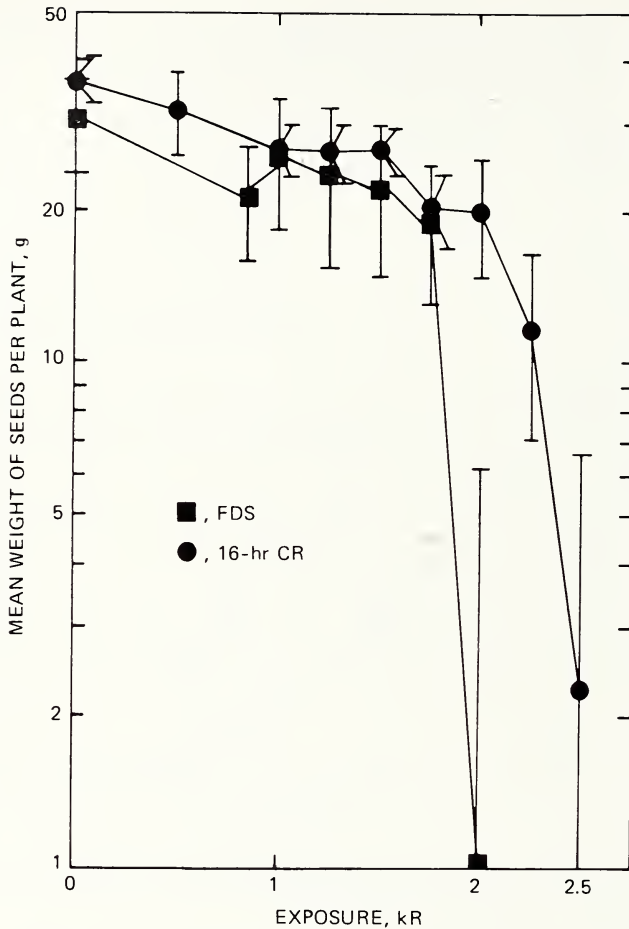

Fig. 6 Log mean weight of seeds per treated plant (in grams) vs. exposure for barley given 36-hr FDS and 16-hr CR treatments. \perp indicates 99% confidence interval.

1000 R/hr. However, very little change in the level of injury was found between 1000 and 4800 R/hr.

DISCUSSION

Most of the results given here may be explained on the basis of exposure rate; i.e., for the same total exposure, more damage occurs with high exposure rates than with low exposure rates. This, of course, is not a new concept in radiobiology, and the literature on the subject is too extensive to be reviewed in

FDS

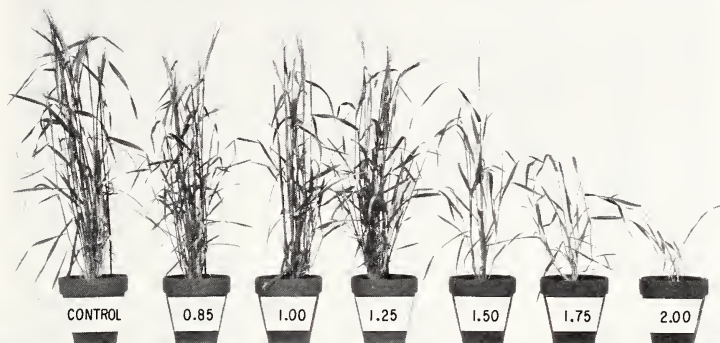

8-hr CR

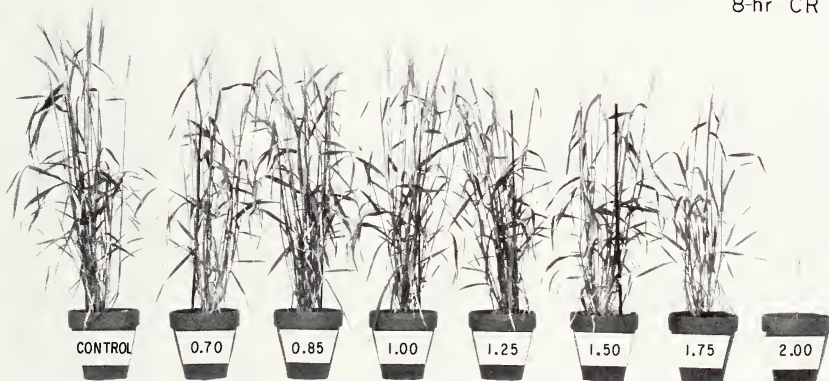

16-hr CR

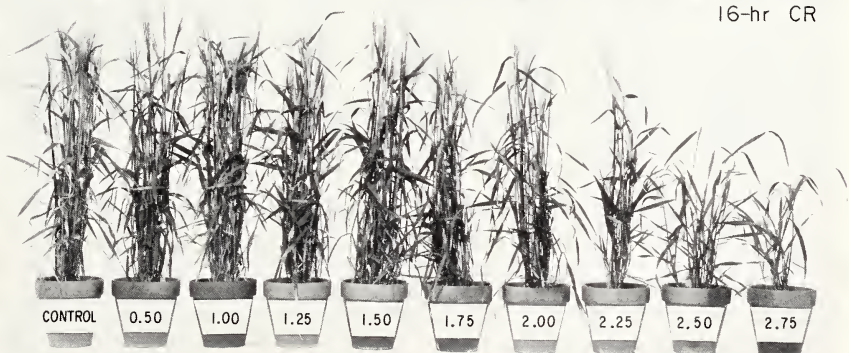

Fig. 7 Representative barley plants from the surviving exposures for 36-hr FDS, 8-hr CR, and 16-hr CR treatments. Exposures are given in kiloroentgens.

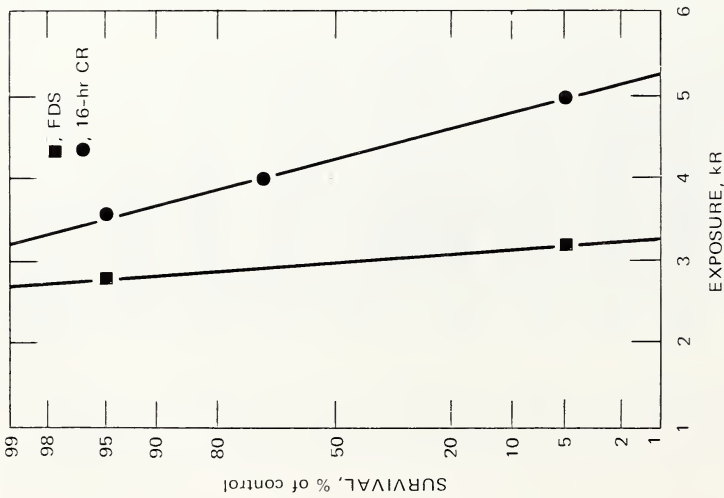

Fig. 8 Probit plot of survival as percent of control vs. exposure for wheat given 36-hr FDS and 16-hr CR treatments.

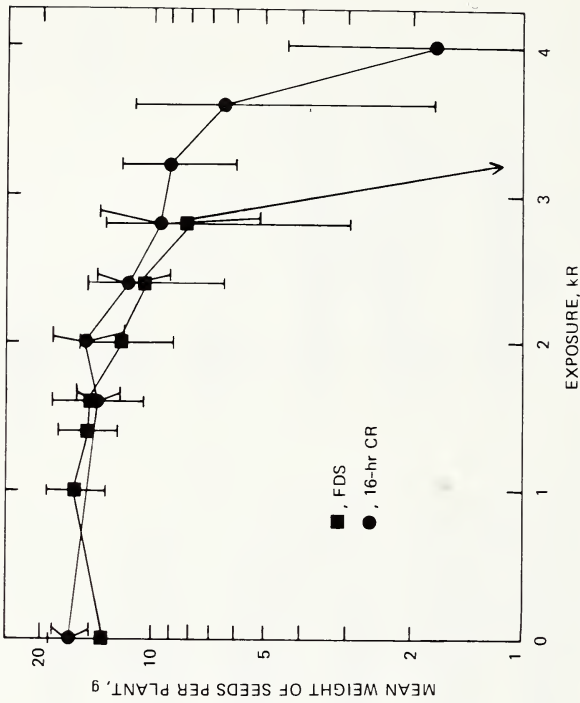

Fig. 9 Log mean weight of seeds per treated plant (in grams) vs. exposure for wheat given 36-hr FDS and 16-hr CR treatments. \perp indicates 99% confidence interval.

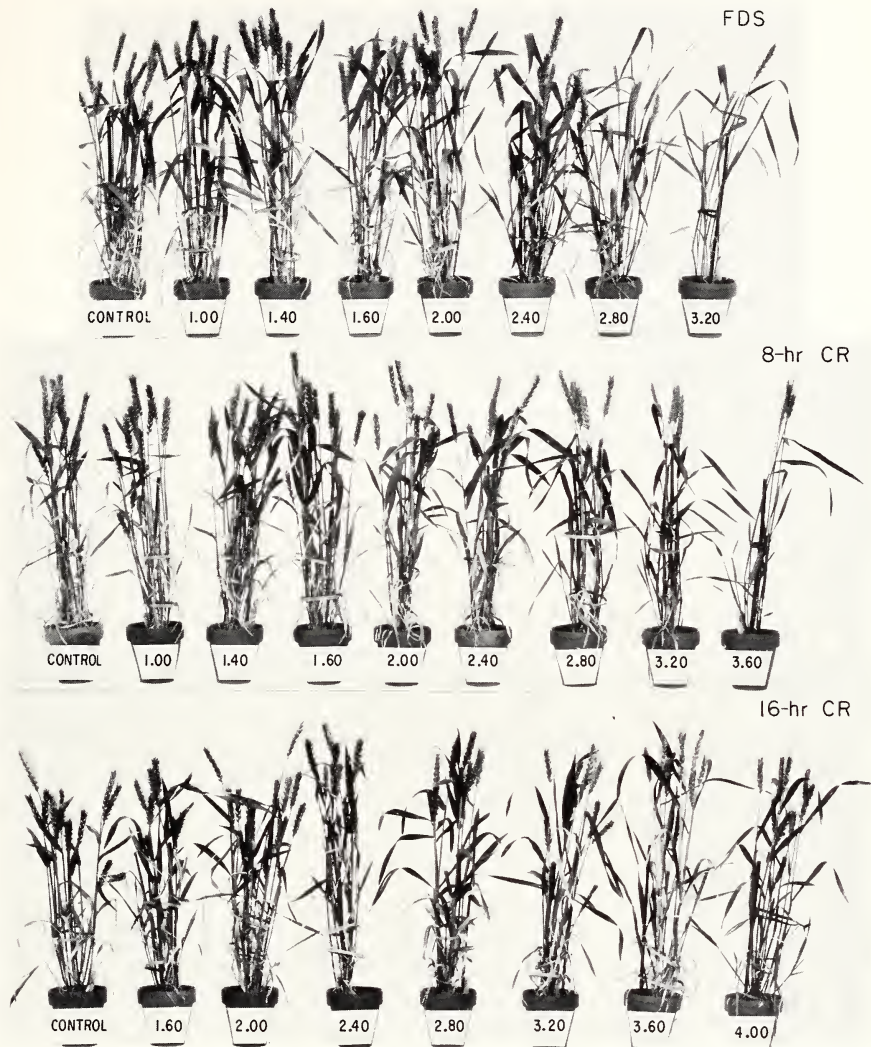

Fig. 10 Representative wheat plants from the surviving exposures of 36-hr FDS, 8-hr CR, and 16-hr CR treatments. Exposures are given in kiloroentgens.

depth here. In the majority of the published work, the effect measured increases with increasing exposure rate. This has been found for survival in *Solanum*,⁵ barley,⁶ *Neurospora*,⁷ and aerobic HeLa cells;⁸ for growth inhibition in *Vicia*^{9,10} and barley roots;¹¹ for chromosome aberrations in pea¹² and barley seeds;¹³ and for mutations in barley⁶ and *Neurospora*.⁷ An oxygen requirement has been shown for the expression of this exposure-rate effect.^{8,14} This need is presumably due to the presence of repair mechanisms that require oxygen and

Table 2
COMPARISON OF LD₅₀ VALUES FOR THE
8-HR CR AND FDS TREATMENTS FOR
LETTUCE, BARLEY, AND WHEAT

Crop	Treatment	LD ₅₀ , kR ± S.D.*	
Lettuce	FDS	4.79 ± 0.05	N.S.†
	8-hr CR	5.03 ± 0.07	
Barley	FDS	1.99 ± 0.08	N.S.
	8-hr CR	1.91 ± 0.04	
Wheat	FDS	3.09 ± 0.71	N.S.
	8-hr CR	3.45 ± 1.12	

*The abbreviation S.D. is standard deviation.

†The abbreviation N.S. means not significant at the 5% level.

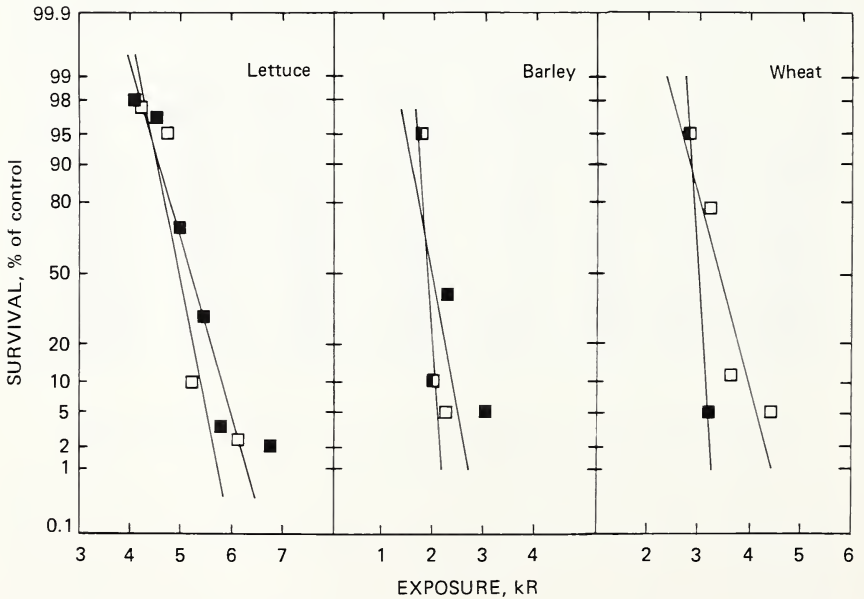

Fig. 11 Comparison of probit plots of survival as percent of control vs. exposure for lettuce, barley, and wheat given 8-hr CR (□) and 36-hr FDS treatments (■).

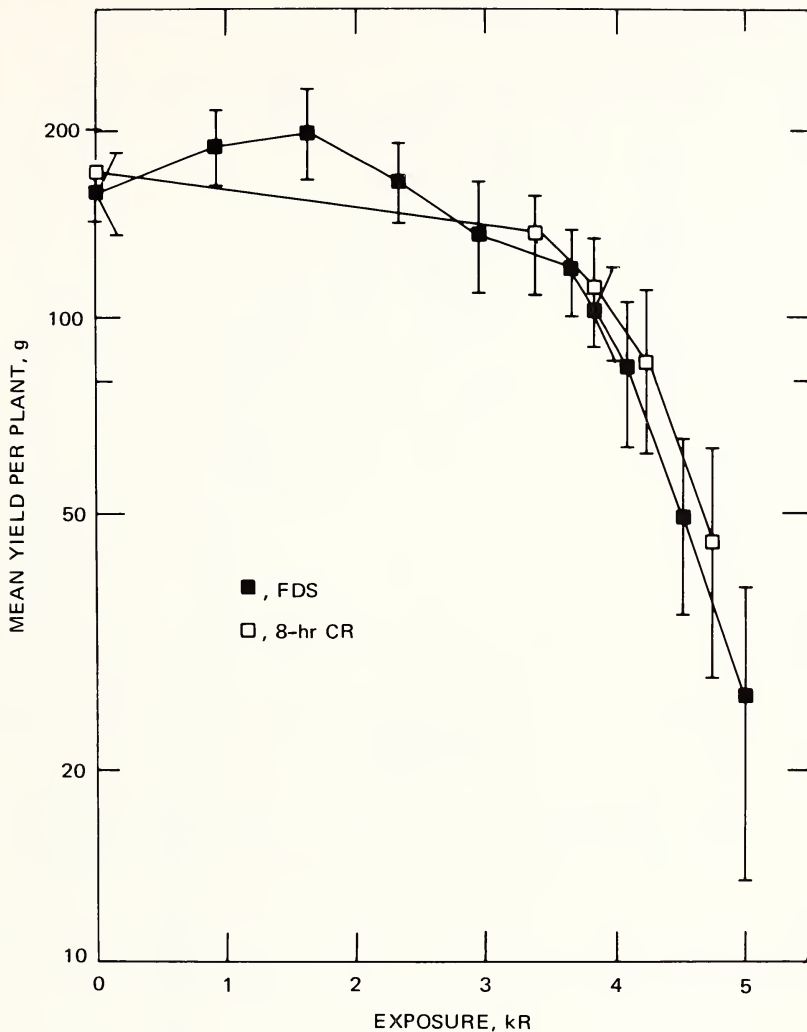

Fig. 12 Log mean weight per treated plant (in grams) vs. exposure for lettuce given 8-hr CR and 36-hr FDS treatments. \perp indicates 99% confidence interval.

function most efficiently at low exposure rates. There are some limits to the exposure-rate effect, however. At very high exposure rates, further increases in rate do not bring about further increases in effect. This is in part a limitation of the system, as shown in the work of McCrory and Grun⁵ where the 100% lethality level imposes an upper limit to the rate effect. This is not to say that an additional exposure-rate effect could not be shown, however; if the total exposure was decreased, there probably would be an additional exposure-rate

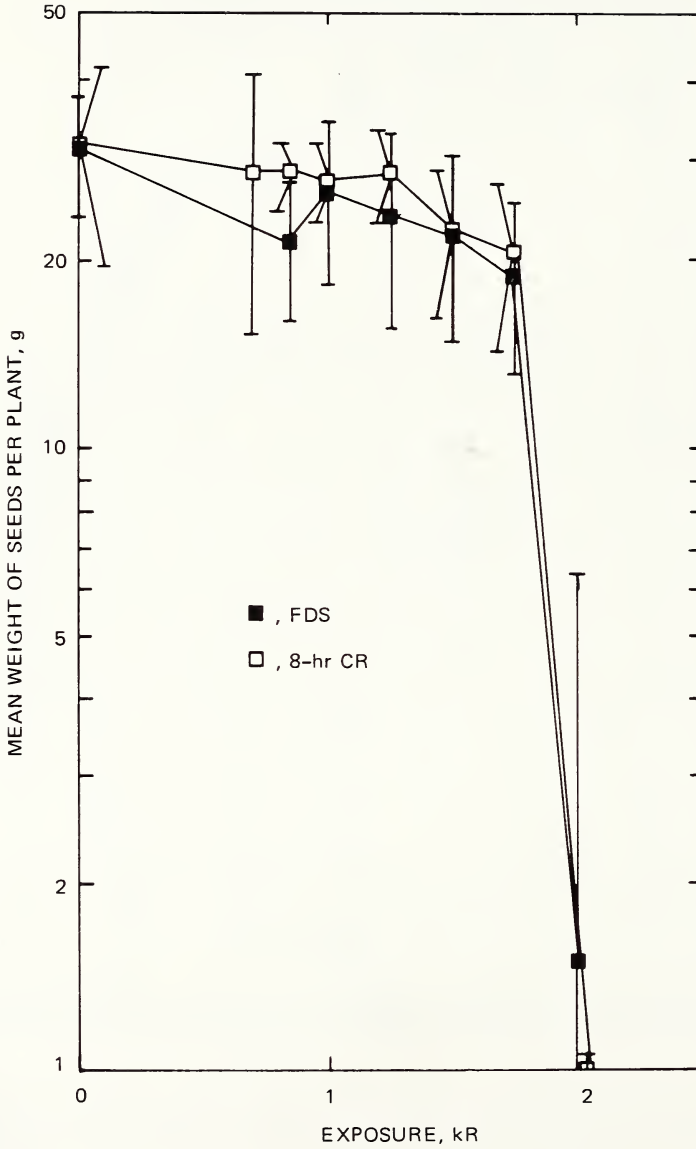

Fig. 13 Log mean weight of seeds per treated plant (in grams) vs. exposure for barley given 8-hr CR and 36-hr FDS treatments. \perp indicates 99% confidence interval.

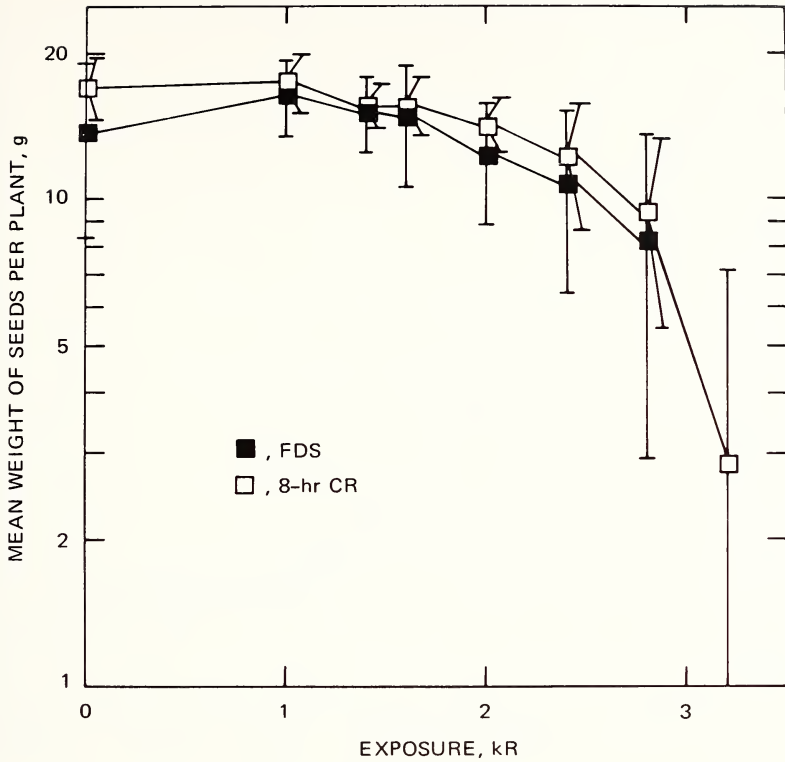

Fig. 14 Log mean weight of seeds per treated plant (in grams) vs. exposure for wheat given 8-hr CR and 36-hr FDS treatments. \perp indicates 99% confidence interval.

effect. At the other end of the response curve, where the exposure rate is very low, a point is reached where no difference between irradiated and nonirradiated plants can be detected. This was observed by Hall and Bedford¹⁰ for growth inhibition in *Vicia* roots and in some studies with chronic irradiation using many species.¹⁵⁻¹⁷ This has led to the conclusion that, although the cumulative exposure is important, the rate at which that exposure is delivered is a more important factor.¹⁷

Thus there is substantial evidence in the literature for the exposure-rate effect reported here. We have observed an increasing effect with increasing exposure rate and have also reached the point in rate where no additional changes in effect occur with increasing rate. Experiments examining the response to lower exposure rates are under way. The most important factors controlling the specific exposure-rate effect are the species and criterion of effect used, the total exposure, and the environmental conditions during and after irradiation. Manipulation of these factors, e.g., lowering the total exposure, may allow one

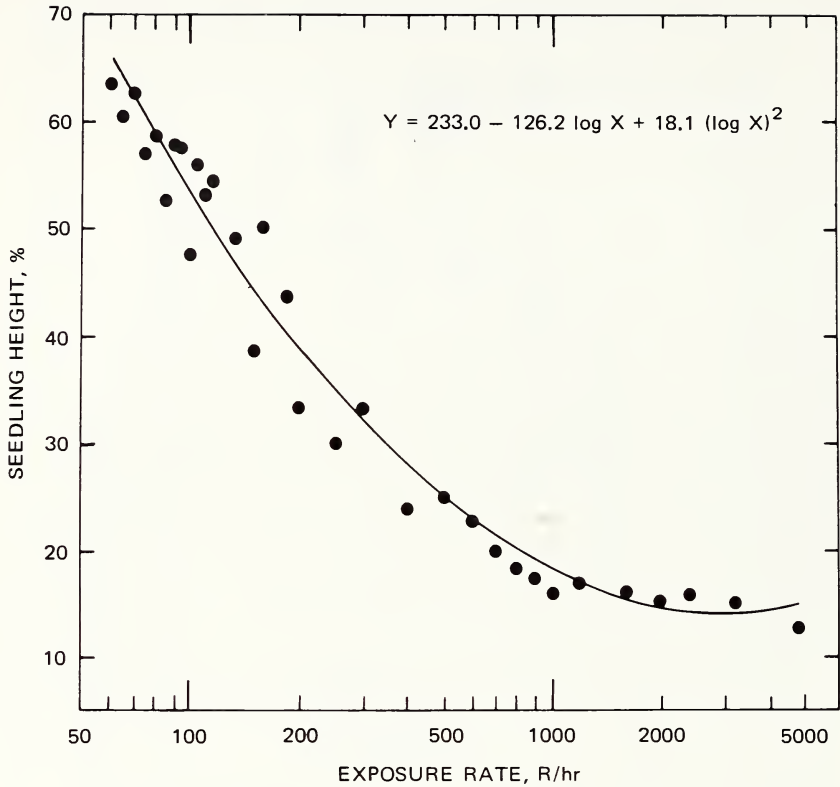

Fig. 15 Seedling height as percent of control vs. log of exposure rate for barley seedlings given a total exposure of 1600 R.

to demonstrate an effect at higher exposure rates since the capacity of the system to respond would be greater under conditions more conducive to expression of the effect.

We have reported both here and previously^{1,2} that the FDS treatment is more effective in reducing survival and yield than the 16-hr CR treatment. The ratios of exposures at the LD₅₀ for 16-hr CR to FDS are 1.43 for lettuce, 1.23 for barley, and 1.37 for wheat; these ratios agree well with the average of 1.4 for seven other species previously reported. The constant difference between the two treatments which was observed for survival was not observed for yield. At exposures up to the region of the FDS LD₅₀, little difference between the two treatments was observed. Above this exposure the yield for the FDS treatment falls off much more rapidly than the yield for the 16-hr CR treatment, and there is clearly a difference between the two. This difference in effectiveness is due to the very high exposure rates encountered in the early part of the FDS treatment. The average exposure rate in roentgens per hour (weighted for the shield

timings) for a 5000-R exposure was calculated to be 791 R/hr for an FDS treatment as compared with 312.5 R/hr for the same total exposure from a 16-hr CR treatment. Thus the greater effectiveness of the FDS treatment can be explained by this difference of about 2.5 times in exposure rate. The fact that the survival and yield criteria for the FDS and Bu + FDS treatments are not greatly different is due to the use of essentially the same exposure-rate patterns for the two types of treatments (see Fig. 1).

The barley-seedling-height experiment shows that radiation damage increases with increasing exposure rate at rates below 1000 R/hr and provides additional support for our conclusion that the greater effectiveness of the FDS treatment is due to the initial high exposure rates. About 40% of the total exposure of 5000 R, which was lethal for lettuce, wheat, and barley, was given at 1300 R/hr. Although the criterion of effect studied was seedling-height reduction, it can be assumed that the survival and grain yield would also respond in a similar manner to variations in exposure rate. Thus the high overall exposure rate would be more than adequate to explain the increased effectiveness of the FDS treatment.

The similarity in effect between the 8-hr CR treatment and the FDS treatment is interesting from a practical standpoint. The exposure rates for the two treatments, compared for a 5000-R exposure, were found to be 625 R/hr for the 8-hr CR exposure and 791 R/hr for the FDS exposure. On this basis we would predict a similar level of effect for the two treatments if exposure rate played an important role in determining the level of damage. This finding is important since it implies that laboratories lacking the facilities to simulate fallout decay may obtain similar results by using 8-hr CR treatments. Although the 8-hr CR wheat data deviate somewhat from the FDS data for survival, the similarity between the FDS and the 8-hr CR data for all crops is very good, and relevant data on survival and yield for other crops can be made by using 8-hr CR treatments.

ACKNOWLEDGMENTS

We wish to thank Brenda Floyd, Susan S. Schwemmer, E. E. Klug, Leanne Puglielli, J. Newby, R. Sautkulis, Pamela Silimperi, and J. Bryant for assistance with the irradiations and data collection; R. A. Nilan for supplying the barley seed; and C. F. Konzak for supplying the wheat seed. The assistance of K. H. Thompson with statistics and Virginia Pond and Susan S. Schwemmer with critical comments on the manuscript is also acknowledged.

This research was carried out at Brookhaven National Laboratory under the auspices of the U. S. Atomic Energy Commission and the Office of Civil Defense, Department of the Army, Washington, D. C., under Project Order No. DAHC20-69-C 0167, Work Unit 3133E. Contracting office technical representative was D. W. Bensen. This report has been reviewed and approved for publication by the Office of Civil Defense. Approval does not signify that the contents necessarily reflect the views and policies of the Office of Civil Defense.

REFERENCES

1. A. H. Sparrow and Leanne Puglielli, Effects of Simulated Radioactive Fallout Decay on Growth and Yield of Cabbage, Maize, Peas and Radish, *Radiat. Bot.*, **9**: 77-92 (1969).
2. A. H. Sparrow, Brenda Floyd, and P. J. Bottino, Effects of Simulated Radioactive Fallout Buildup and Decay on Survival and Yield of Lettuce, Maize, Radish, Squash, and Tomato, *Radiat. Bot.*, **10**: 445-455 (1970).
3. G. M. Clark, F. Cheng, R. M. Roy, W. P. Sweaney, W. R. Bunting, and D. G. Baker, Effects of Thermal Stress and Simulated Fallout on Conifer Seeds, *Radiat. Bot.*, **7**: 167-175 (1967).
4. R. R. Myhill and C. F. Konzak, A New Technique for Culturing and Measuring Barley Seeds, *Crop Sci.*, **7**: 275-276 (1967).
5. J. McCrory and P. Grun, Relationship Between Radiation Dose Rate and Lethality of Diploid Clones of *Solanum*, *Radiat. Bot.*, **9**: 27-32 (1969).
6. A. Silvy and P. Pureau-Leroy, Effets genetiques d'irradiations gamma de courte duree et à differents debits de dose sur des plants d'orge (var. Piroline) en cours de développement, in *Induced Mutations in Plants*, Symposium Proceedings, Pullman, Wash., 1969, pp. 181-193, International Atomic Energy Agency, Vienna, 1969 (STI/PUB/231).
7. F. J. de Serres, H. V. Malling, and B. B. Webber, Dose-Rate Effects on Inactivation and Mutation Induction in *Neurospora crassa*, in Recovery and Repair Mechanisms in Radiobiology, Brookhaven Symposia in Biology Number 20, June 5-7, 1967, Upton, N. Y., USAEC Report BNL-50058, pp. 56-76, Brookhaven National Laboratory.
8. E. J. Hall, J. S. Bedford, and R. Oliver, Extreme Hypoxia; Its Effect on the Survival of Mammalian Cells Irradiated at High and Low Dose Rates, *Brit. J. Radiol.*, **39**: 302-307 (1966).
9. E. J. Hall and J. Cavanagh, The Oxygen Effect for Acute and Protracted Radiation Exposures Measured with Seedlings of *Vicia faba*, *Brit. J. Radiol.*, **40**: 128-133 (1967).
10. E. J. Hall and J. S. Bedford, A Comparison of the Effect of Acute and Protracted Gamma Radiation on the Growth of Seedlings of *Vicia faba*. Part 1. Experimental Observations, *Int. J. Radiat. Biol.*, **8**: 467-474 (1964).
11. L. Cercek, M. Ebert, and D. Greene, RBE, OER, and Dose-Rate Effects with 14 MeV Neutrons Relative to 300 kVp X-Rays in Barley Roots, *Int. J. Radiat. Biol.*, **14**: 453-462 (1969).
12. A. M. Akopyan, Effect of Different Types of Ionizing Radiations in Peas. II. Dose and Dose Rate Effects on the Frequency of Chromosomal Aberrations of Pea Seeds After Gamma Irradiation, *Genetika*, **7**: 34-38 (1967).
13. K. A. Filev, Postirradiation Seed-Storage Effect as Related to Irradiation Dose and Rate, *Dokl. Akad. Nauk SSSR*, **169**: 680-682 (1966).
14. D. L. Dewey, An Oxygen Dependent X-Ray Dose-Rate Effect in *Serratia marcescens*, *Radiat. Res.*, **38**: 467-474 (1969).
15. J. M. Bostrack and A. H. Sparrow, The Radiosensitivity of Gymnosperms. II. On the Nature of Radiation Injury and Cause of Death of *Pinus rigida* and *P. strobus* After Chronic Gamma Irradiation, *Radiat. Bot.*, **10**: 131-143 (1970).
16. G. M. Woodwell and A. H. Sparrow, Predicted and Observed Effects of Chronic Gamma Radiation on a Near-Climax Forest Ecosystem, *Radiat. Bot.*, **3**: 231-237 (1963).
17. J. E. Gunckel, A. H. Sparrow, Ilene B. Morrow, and Eric Christensen, Vegetative and Floral Morphology of Irradiated and Non-Irradiated Plants of *Tradescantia paludosa*, *Amer. J. Bot.*, **40**: 317-332 (1953).

DOSE-FRACTIONATION STUDIES AND RADIATION-INDUCED PROTECTION PHENOMENA IN AFRICAN VIOLET

C. BROERTJES

Institute for Atomic Sciences in Agriculture, Wageningen, The Netherlands

ABSTRACT

Leaves of African violet, which develop adventitious buds on petioles after rooting, have been used as test material for dose-fractionation studies with X rays and fast neutrons. The parameters used were survival of the leaves, production of adventitious plantlets per leaf, and mutation frequency.

The aim of the experiments was to determine the relation between initial dose, time interval, and the extent of the radioinduced protection. The "optimal" initial dose inducing maximal protection (equivalent to approximately 3 krads) proved to be 500 rads of X rays and fast neutrons at an "optimal" time interval of 8 to 12 hr.

Repeated irradiations with the optimal initial dose at 8-hr time intervals induce a protection much higher than that of a single pretreatment, reaching a maximum after approximately 10 irradiations.

No qualitative differences were found between X rays and fast neutrons. The relative biological effectiveness (RBE) for protection is found to be 1, whereas the RBE for acute irradiations is 2.

The results presented are discussed and compared with literature data dealing mainly with mammals. A few questions arise about the significance of the phenomena described in relation to radiotherapeutic procedures.

African violet, *Saintpaulia ionantha* 'Utrecht', was used to study the effects of acute and chronic irradiation with X rays and fast neutrons. During these experiments a very pronounced dose-rate effect was observed.¹ Dose-fractionation experiments were carried out in an attempt to analyze the mechanisms involved; again both X rays and fast neutrons were used. The experiments described here were carried out to determine the interaction between various initial doses, time intervals, and repeated irradiations and the radiosensitivity of the material.

The results are discussed in terms of radioinduced protection or improved radioinduced repair mechanism. It is impossible to decide which term should be

used without knowing exactly the mechanisms involved; protection implies prevention of part of the damage by the radiation, whereas improved repair speaks for itself.

The word "protection" was chosen mainly to emphasize the difference between the normal repair that takes place after acute irradiation and the phenomena described, which occur after fractionated treatments.

The explanation of these phenomena is not a simple one. Many authors have presented possible explanations, but so far none is completely satisfactory. These investigations do not include a study of the mechanisms involved but are concerned with more-practical mutation breeding and consequently do not contribute to an explanation of the protection phenomena observed.

MATERIAL, PARAMETERS, AND IRRADIATION FACILITIES

Material

African violet, which belongs to the Gesneriaceae, was selected as an experimental plant for various reasons. It forms medium-size plants that can be grown without difficulties under proper greenhouse conditions throughout the year. The species reproduces easily from leaf cuttings, which, after rooting, produce 10 to 20 plantlets per leaf from adventitious buds formed at the base of the petiole. These adventitious plantlets can be separated from the mother leaf, transplanted in boxes or pots, and grown to maturity.

This reproduction system, the so-called adventitious bud technique, was chosen for one important reason: Every adventitious plantlet ultimately originates from only one epidermal cell; this results in solid, nonchimeral mutants if this cell carries a mutation. After any mutagenic treatment, whether short (minutes) or very long (up to 4 weeks), the lower 5 mm of the petiole, the region where the adventitious buds are formed, was cut off. In this way it was ascertained that the epidermal cells situated higher up the petiole, which had undergone the whole treatment as nondividing, resting cells, were stimulated to develop the adventitious buds. This procedure avoided the consequences arising from differences in radiosensitivity caused by different cell-division stages as well as the chimera formation resulting from mutation induction in the developing multicellular meristems during a prolonged treatment (longer than 3 to 5 days). In general, 20 leaves per treatment were used.

Parameters

Three parameters were used to measure the effect of the irradiation:

1. Survival of the irradiated leaves (in percent of the control). Only leaves that produced at least one plantlet were considered to be alive.
2. Production of plantlets (average number per leaf in percent of the control). This is the most reliable parameter and generally reacts very sharply

depending on the intensity of the treatment. Untreated leaves produce approximately 15 plantlets per leaf.

Survival and production were determined 4 to 5 months after planting during separation of the plantlets from the mother leaf.

3. Mutation frequency. This was determined approximately 3 months after the separation when the plants were large enough for variations in size, form, habit, and color of leaf and plant to be distinguished. This is the least reliable parameter since habit, size, and other visible characteristics vary with differences in climatic and other conditions and, in addition, are influenced by the previous treatments. The decision to consider a plant a mutant was often an arbitrary one.

Irradiation Facilities

X rays were applied with a Philips 250/25 deep-therapy apparatus, usually operating at 250 kV and 15 mA without an additional filter. The dose rate applied was always 200 rads/min. Temperature was the only climatic condition controlled during irradiation.

Fast-neutron irradiations were carried out in the sub-core irradiation room of the Biological Agricultural Reactor Netherlands (BARN). When the facility was operating at full power, a dose rate of 1000 rads/hr in H₂O was obtained in the irradiation position. Since *Saintpaulia* leaves contain 97 to 98% H₂O, this may be considered as the dose rate in the material.

The fast-neutron spectrum is similar to a fission spectrum and has an average energy of approximately 2 MeV. The gamma contamination amounts to 80 rads/hr (Ref. 2).

RESULTS

In this discussion of the results of the dose-fractionation experiments, I will refer often to the acute-dose-effect curves. As can be seen in Figs. 1 and 2, the form of the curves is almost identical for X rays and fast neutrons. The only difference is that on a rad basis fast neutrons from the BARN reactor have a relative biological effectiveness (RBE) for the three parameters used of approximately 2 compared with the X rays. The results presented here indicate that both radiations are qualitatively alike.

The first experiment, in which two equal semilethal doses (50% of the sublethal X ray dose of 6 krads) were applied at various time intervals, clearly showed that after an interval of more than 8 to 12 hr the effect of the two fractions was identical with the effect of only one fraction for both survival (Fig. 3) and production (Fig. 4). It can be seen, especially from Fig. 4, that the first dose must have induced some kind of change resulting in a mechanism that develops in time, reaches a maximum after approximately 12 hr, and gradually breaks down in the following days; it was still noticeable, however, after 120 hr.

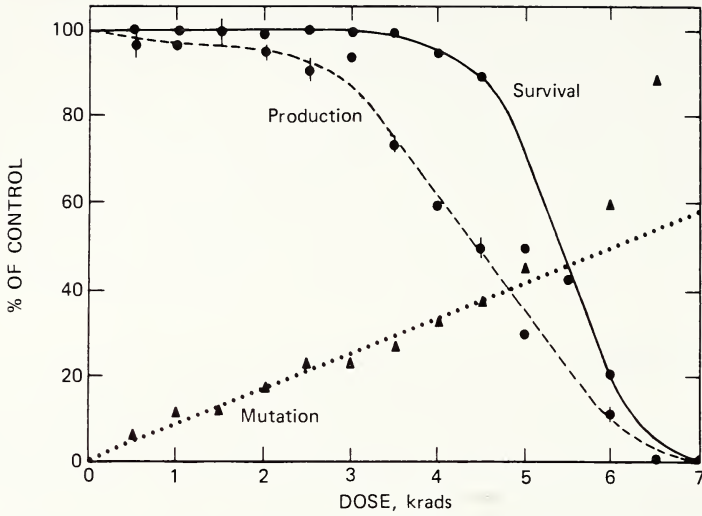

Fig. 1 Dose-effect curves after acute X-ray treatments (200 rads/min) of African violet leaves.

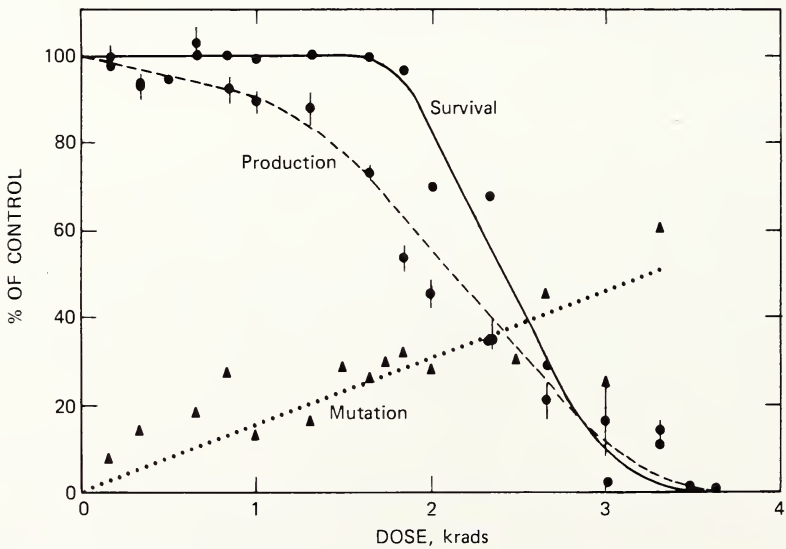

Fig. 2 Dose-effect curves after acute fast-neutron treatments (1000 rads/hr) of African violet leaves.

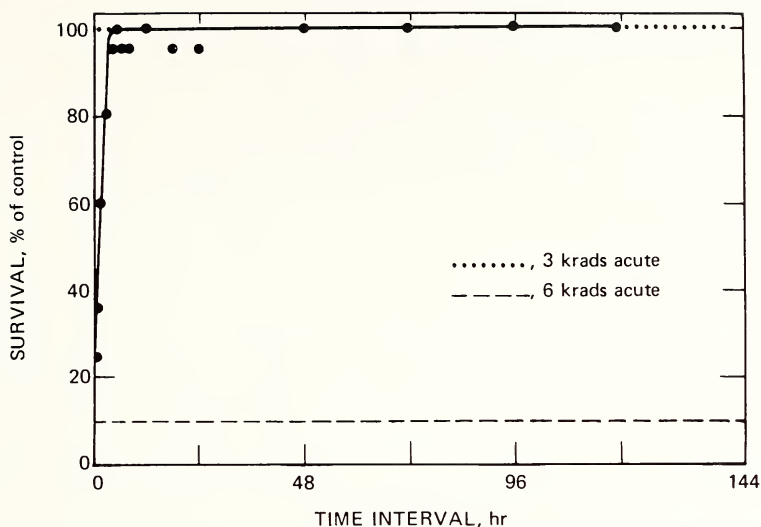

Fig. 3 Effect on survival of two semilethal X-ray doses (3 krads) given at various time intervals.

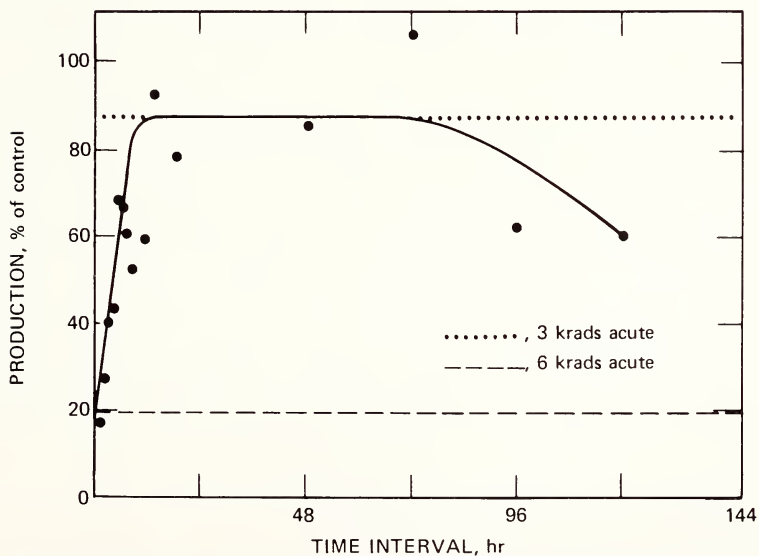

Fig. 4 Effect on production of two semilethal X-ray doses (3 krads) given at various time intervals.

As mentioned previously, it was decided to use the word "protection" for this mechanism.

Various questions arise: (1) Can an optimal initial dose be determined which induces a maximal protective effect in the leaves? (2) What is the relation between protection and the time interval separating the initial dose and the second dose? (3) What is the extent of the protection? And (4) What is the effect of repeated irradiation with the optimal initial dose at the optimal time interval.

Initial Dose

Various initial doses have been applied, ranging from very small ones (1-, 10-, 30-, 75-, and 150-rad X-ray doses and comparable doses of fast neutrons) up to the semilethal X-ray dose of 3 krad. These were followed, after the optimal time interval (8 hr, see the following section), by a series of second doses, i.e., the semilethal X-ray dose of 3 krad, the sublethal dose of 6 krad and a number of lethal doses (7, 8, 9, and 10 krad) and comparable fast-neutron doses. The high second doses were given to test the extent of the protection.

As can be seen in Figs. 5 and 6 (survival and production, respectively, after various initial doses of X rays or fast neutrons), a very pronounced protective effect is initiated by a first dose of 500 to 1000 rads of X rays or fast neutrons. The exact optimum is hard to define since a fairly large dose range, covering a few hundred rads, induces almost maximal protection. Moreover the optimum depends on the extent of the second dose. A larger second dose requires a larger initial dose for maximal protection; this indicates a small increase in protection with increasing initial dose in the dose range mentioned.

To define the optimal initial dose, we must take into account the nonrepaired effects of the initial dose. They mask the effect of the protection, especially when higher initial doses are applied, because their contribution to the total effect increases with dose. The choice of the optimal initial dose has therefore fallen on an initial dose in the lower region of the dose range inducing nearly maximal protection, i.e., 500 rads of X rays or fast neutrons.

Unfortunately some preliminary experimental results suggested that 170 rads of fast neutrons was the optimal initial dose in African violet. This means that a few experiments were carried out with repeated irradiations with fast neutrons at a suboptimal initial dose; these cannot be directly compared with the repeated X-ray irradiation using the optimal initial dose (see the section on repeated irradiation).

Time Interval

The initial dose, selected to study the effect of time interval (500 rads of X rays or 170 rads of fast neutrons), was separated from the second dose (generally 3 krad of X rays or 1700 rads of fast neutrons and 6 krad of X rays

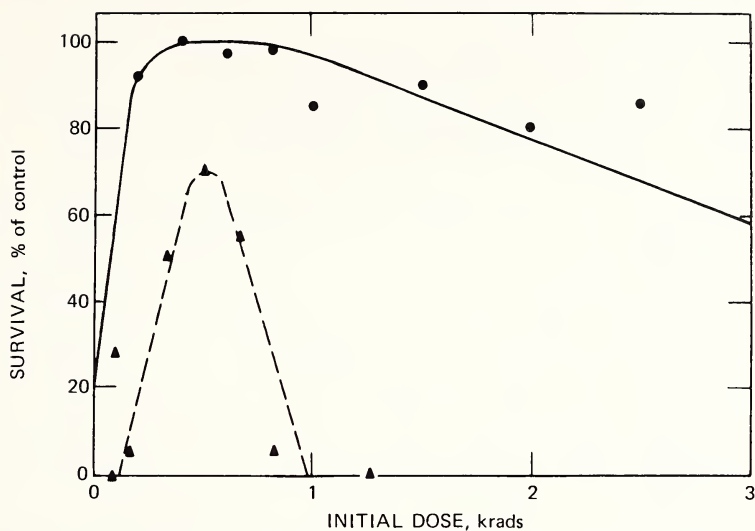

Fig. 5 Effect of various initial doses on survival. Second doses were 6-krad X rays (—) and 3.3-krad fast neutrons (- - -); there was an 8-hr time interval between first and second doses.

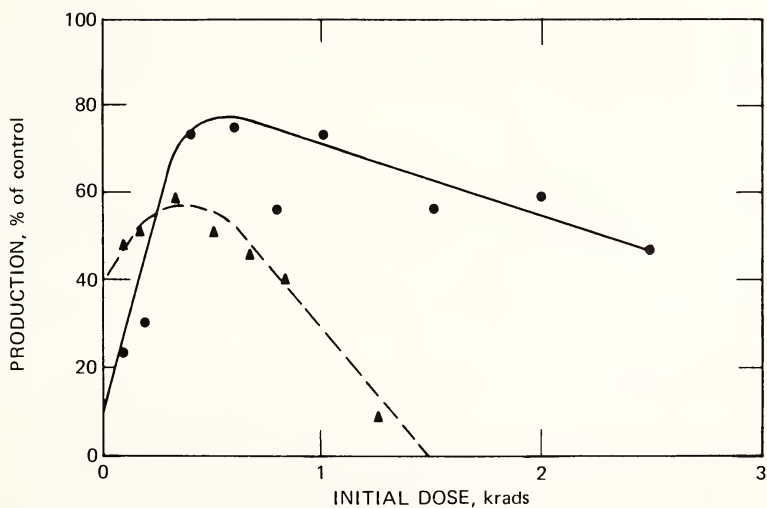

Fig. 6 Effect of various initial doses on production. Second doses were 5-krad X rays (—) and 2.5-krad fast neutrons (- - -); there was an 8-hr time interval between first and second doses.

or 3400 rads of fast neutrons) by time intervals ranging from 1 to 12 hr and from 24 to 240 hr.

As is shown in Figs. 7 and 8, a protective mechanism builds up very rapidly, reaching its maximum after 8 to 12 hours and gradually decreasing with increasing time interval. After approximately 120 hr the protective effect has disappeared almost completely regardless of the type of radiation used.

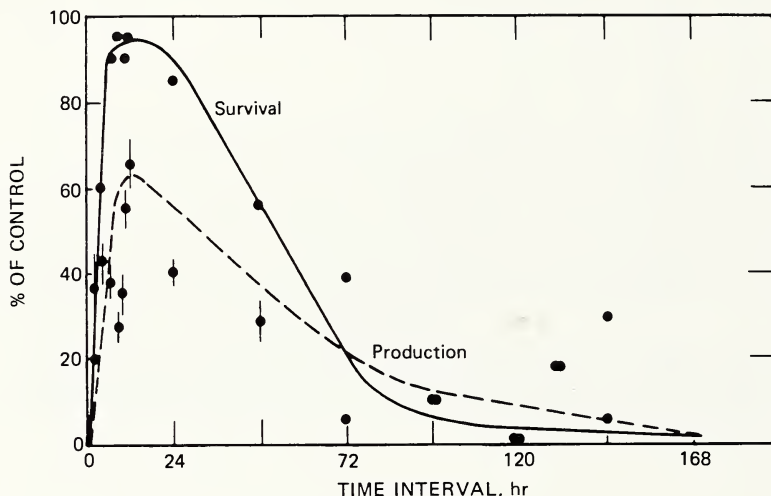

Fig. 7 Effect of various time intervals on survival and production at an initial X-ray dose of 500 rads and a second X-ray dose of 6 krad. At 6 krad there is approximately 10% survival and approximately 20% production; an X-ray dose of 6.5 krad is lethal.

In relation to the repeated irradiations planned, the optimal time interval was defined as the shortest time needed for maximal protection. The selected time interval of 8 hr permitted 60 repeated irradiations of the material with the optimal initial dose within 20 days. A time interval of 12 hr would have extended the experiment to 30 days, which is too long for the separated leaves to remain in sealed plastic bags.

Extent of Protection

A series of high second doses, most of which are lethal when given as an acute single dose, were applied to test the extent of the radioinduced protection. As can be seen in Fig. 9, even after an X-ray dose of 9 or 10 krad, or comparable fast neutron doses, on the basis of an RBE of 2.0, there is a surviving fraction corresponding to an acute single dose approximately 3 krad lower. In other words, a low initial dose of 500 rads induces a protective mechanism with an extent of approximately 3 krad.

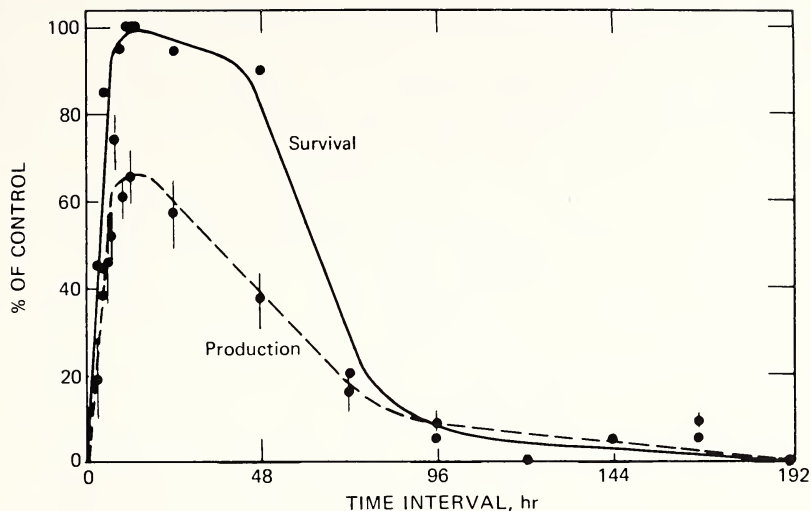

Fig. 8 Effect of various time intervals on survival and production at an initial fast-neutron dose of 170 rads and a second fast-neutron dose of 3.4 krad; fast-neutron doses of 3.3 and 3.5 krad are lethal.

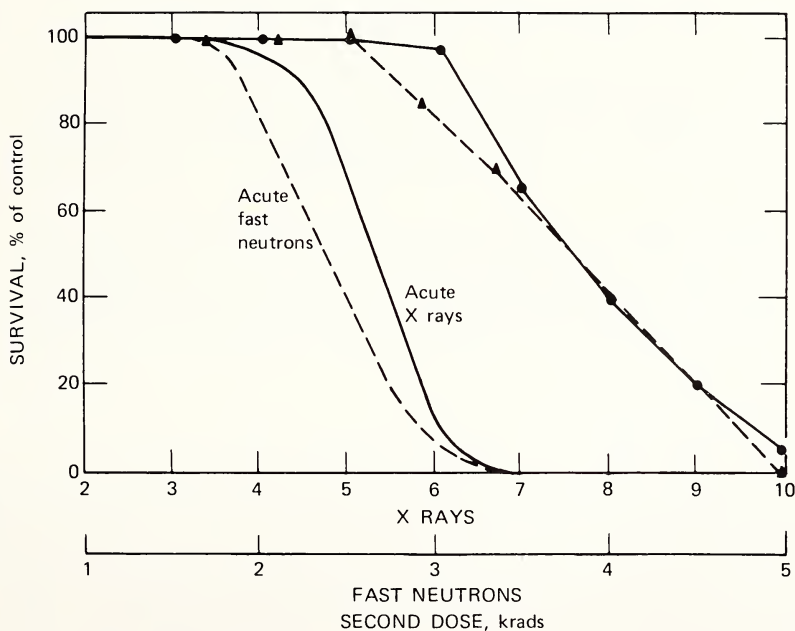

Fig. 9 Extent of protection induced by an initial X-ray dose of 600 rads (—●—) or an initial fast-neutron dose of 500 rads (---▲---), tested by applying various second doses of X rays or fast neutrons after an 8-hr interval.

This is also very clearly demonstrated by an experiment in which an optimal initial X-ray dose (500 rads) or the suboptimal fast-neutron dose of 170 rads preceded a series of second doses of either fast neutrons or X rays by an 8-hr time interval. The distance between the acute lines and the other, parallel, lines is approximately 3 krad, as is shown in Figs. 10 and 11, again on the basis of an RBE of 2.0.

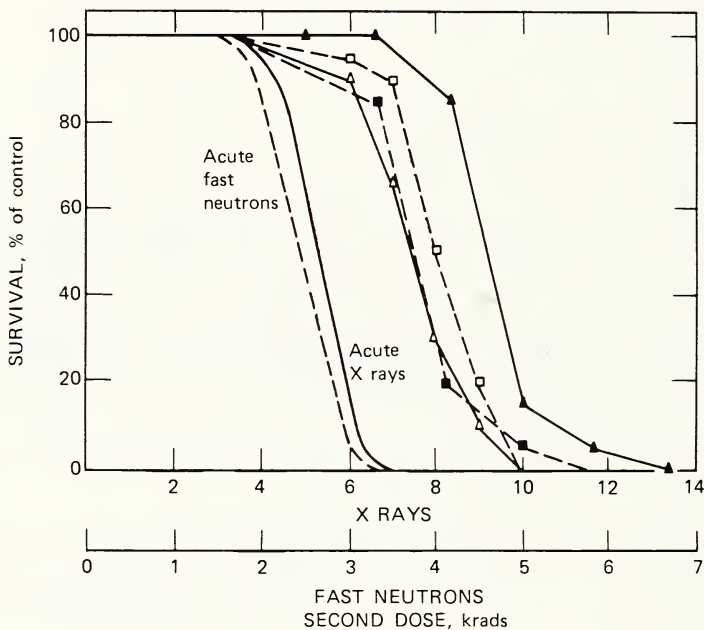

Fig. 10 Effect on survival of the optimal initial dose (500 rads of X rays or 170 rads of fast neutrons) after various second doses of X rays or fast neutrons. — \triangle —, both initial and second doses of X rays; — \blacktriangle —, initial dose of X rays, second dose of fast neutrons; — \blacksquare —, both initial and second doses of fast neutrons; and — \square —, initial dose of fast neutrons, second dose of X rays.

Repeated Irradiation

To investigate whether repeated irradiation with the optimal initial dose at optimal time intervals would result in increased, decreased, or equal protection, we applied 500-rad X-ray or 170-rad fast-neutron doses repeatedly at 8-hr intervals. During the treatment the leaves were sealed in plastic bags and kept in the dark except during handling and irradiation. The temperature was kept at approximately 20°C. After 1, 5, 10, 15, etc., to 60 repetitions, a series of higher doses was applied to test the protection, i.e., X-ray doses of 1.5, 3, 4.5, 6, 8, and 10 krad or fast-neutron doses of 0.8, 1.7, 2.5, 3.4, 5, and 6.8 krad.

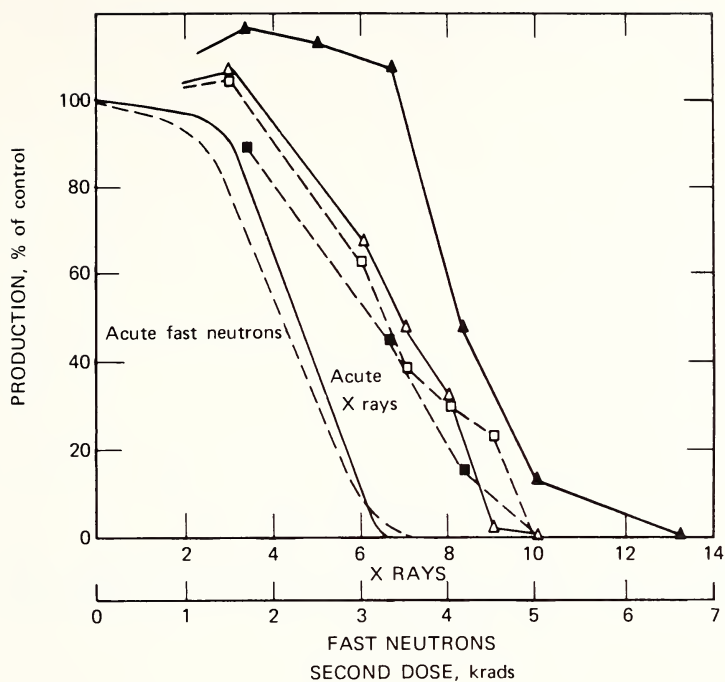

Fig. 11 Effect on production of the optimal initial dose (500 rads of X rays or 170 rads of fast neutrons) after various second doses of X rays or fast neutrons. —△—, both initial and second doses of X rays; —▲—, initial dose of X rays, second dose of fast neutrons; —■—, both initial and second doses of fast neutrons; —□—, initial dose of fast neutrons, second dose of X rays.

As can be seen in Figs. 12 and 13, which are based on the same data but are presented differently (i.e., survival at an initial X-ray dose of 500 rads), the protection increases drastically with the number of repetitions. After from 5 to 60 repetitions, all high doses applied (including 10-krad X-ray doses) result in 100% survival.

Similar results are obtained with fast neutrons (Figs. 14 and 15); these data also show clearly that the protection reaches a maximum after 5 to 15 repetitions and then decreases fairly rapidly. This can also be seen in Fig. 16, in which the values of Fig. 15 are corrected for accumulated unrepaired damage of the repeated irradiations as well as for storage. (Storage for 3 weeks causes a decrease in survival and production.)

When the results obtained after repeated exposures are compared with those after a single pretreatment, it is obvious that the extent of the protection increases considerably after a few irradiations at the optimal initial dose and reaches a value that is much higher than the best single pretreatment. For

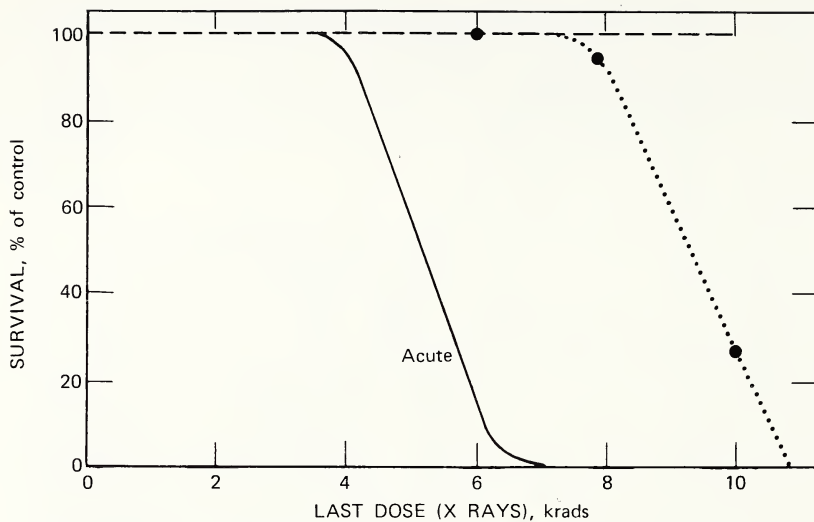

Fig. 12 Effect on survival of repeated X irradiations of 500 rads at 8-hr intervals; various last doses of X rays were applied. . . • . . , one pretreatment with 500 rads; - - - , 5 to 60 repetitions.

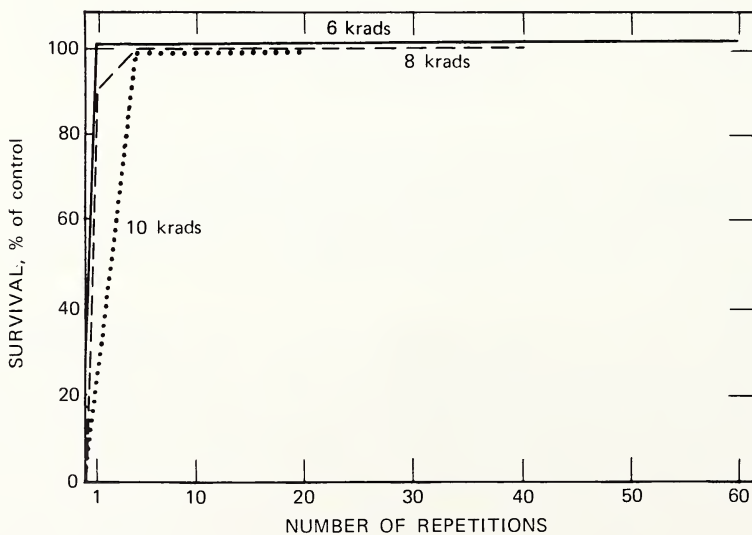

Fig. 13 Effect on survival of repeated X irradiations of 500 rads at 8-hr intervals; various last doses of X rays were applied.

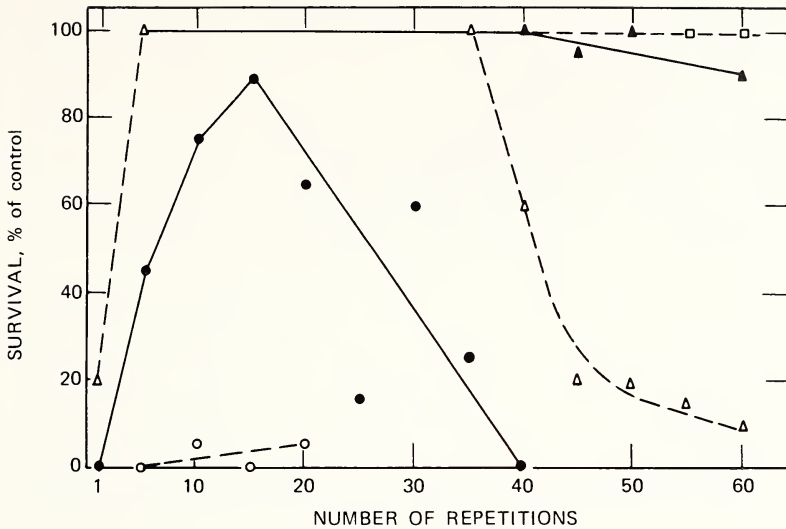

Fig. 14 Effect on survival of repeated fast-neutron irradiations of 170 rads at 8-hr intervals. Last doses of fast neutrons were 6.7 krad (-○-), 5 krad (-●-), 3.4 krad (-△-), 1.7 krad (-▲-), and 170 rads (-□-).

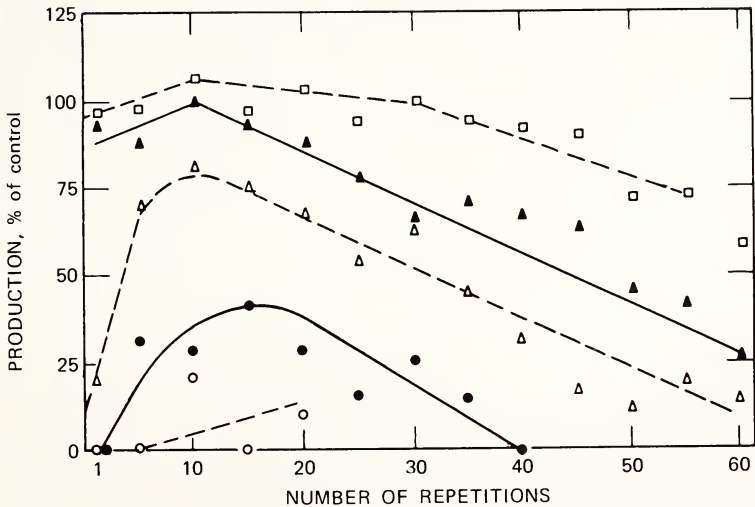

Fig. 15 Effect on production of repeated fast-neutron irradiations of 170 rads at 8-hr intervals. Last doses of fast neutrons were 6.7 krad (-○-), 5 krad (-●-), 3.4 krad (-△-), 1.7 krad (-▲-), and 170 rads (-□-).

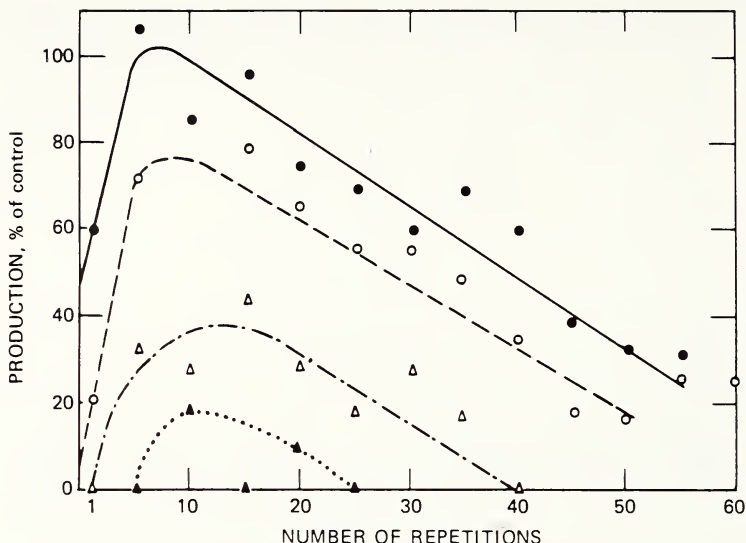

Fig. 16 Effect on production of repeated fast-neutron irradiations of 170 rads at 8-hr intervals; various last doses of fast neutrons were applied; and corrections for pretreatment and storage were made. —, 2.5 krad; - - -, 3.4 krad; - · - ·, 5 krad; and · · · ·, 6.7 krad.

example, a fast-neutron dose of 5 krad applied after 15 repetitions of 170 rads of fast neutrons gives a survival rate of approximately 90% (Fig. 14), whereas 5 krad after the optimal initial fast-neutron dose of 500 rads is just about lethal (Fig. 9). For an initial X-ray dose of 10 krad, these figures are 100 and 0%, respectively (Figs. 13 and 9).

From these figures it would appear that fast neutrons are less effective in the induction of protection than are X rays. But it should be borne in mind that the repeated fast-neutron irradiations were carried out at the suboptimal initial dose of 170 rads. Moreover, the results presented in Figs. 10 and 11 counteract this impression, especially when the suboptimal 170-rad fast-neutron line is replaced by the optimal 500-rad fast-neutron line of Fig. 9.

DISCUSSION

Comparison of X Rays and Fast Neutrons

As mentioned previously, no fundamental difference in action of X rays and fast neutrons from the BARN reactor is evident. It is known that 14-MeV neutrons have a much more pronounced direct effect and consequently do not show much dose-rate effect when compared with neutrons having an average energy of 2 MeV. This is demonstrated very clearly in Figs. 10 and 11, which

present the results of an experiment in which a pretreatment of X rays or fast neutrons was followed by second doses of X rays or fast neutrons after an 8-hr time interval.

From the experimental results it appears that the optimal initial dose for protection is 500 rads of X rays or fast neutrons. Thus the RBE for protection is 1, but, for survival and production [after both acute and fractionated exposures (Figs. 1 and 2 and 10 and 11, respectively)], the RBE has been found to be 2. No explanation of this interesting result can be given at the moment.

Radiation-Induced Protection

Most literature on this subject deals with microorganisms (*Saccharomyces*), with mammalian cells in vitro, or with animals (chickens, dogs, goats, mice, monkeys, pigs, rabbits, rats, and sheep). Generally, whole animals are used to study the effect of one or more pretreatments (initial dose, primary dose, conditioning dose) prior to a second total-body (mass) irradiation after various time intervals. Survival or mortality is generally the parameter used, as for example, by Christian et al.³ for the chicken. Some experimenters irradiated only part of an animal; e.g., Bewley et al.⁴ irradiated the skin of pigs and used skin reactions as a parameter. Others used repopulation as the parameter, as, for example, in the mice studies of Denekamp et al.⁵

A number of authors have tried to review all the data on radioinduced protection and to classify the many different and often confusing observations obtained by various scientists.⁶⁻⁹ Krokowski¹⁰ standardized the results, compared the LD₅₀'s of the radiation effects with and without preirradiation, and put them in a three-dimensional coordinate system.

We can draw a number of general conclusions from all these data:

1. Preirradiation induces a protective mechanism.
2. This protection depends on the intensity of the initial dose, the optimal being approximately 10 to 20% of the LD₅₀.
3. The protection also depends on the time interval between first and second doses. Generally, an interval of 10 to 14 days is required for optimal protection. The protection can last several weeks or even months.
4. A repeated preirradiation is less effective than a single initial irradiation.

Krokowski¹⁰ reported the peculiar and interesting fact that radioinduced protection can be transmitted by injecting the serum from preirradiated animals into nonirradiated animals. The injected animals showed a striking increase in radioresistance.

In plants most dose-fractionation investigations have dealt with the phenomenon of chromosome aberrations. Davies,¹¹ working with white clover, found that, depending on the temperature, protection could be induced by a low initial dose built up rapidly at 25°C and reaching a maximum after approximately 8 hr. At a lower temperature the protection did not decrease even after

4 days. Furthermore, the protection was also dependent on the presence of oxygen; in nitrogen no protection was obtained.

The data presented here agree in part with those in the literature. The optimal initial dose mentioned in the literature is approximately 15% of the LD_{50} , and the extent of the protection induced (increase in tolerance with about 1.7) seems to fit fairly well with the data presented here. In contradiction, however, is the fact that the protection is reported to stay active in animals over an extremely long period whereas in the African violet most of the protective effect has disappeared after 5 days. Also in contradiction is the fact that in animals a single preirradiation induces a better protection than repeated preirradiations. The data presented here clearly demonstrate an optimal protection after a 10- to 20-fold repetition of the preirradiation dose.

A last point to consider is the fact that a 25-fold irradiation with 200-rad X rays is often used in radiotherapy; 200 rads is approximately 5 to 7% of the lethal dose for mammalian cells and is comparable to the optimal initial dose for African violet (500 rads of X rays), which is also approximately 5 to 7% of the lethal dose. A 10- to 25-fold irradiation at this dose induces in African violet a maximal protective effect. This raises the question of whether a similar reaction can be demonstrated in animal tissue. If so, the next question is whether the reaction of normal cells is different from, for instance, that of tumor cells. If, again, this is the case, one wonders whether this could be of importance for radiotherapy in man, realizing, of course, that it is unrealistic to compare African violet with man in view of the differences in tissue, cell type, chemical composition, chromosome size, and oxygenation, to mention but a few.

Mutation Frequency

The original aim of the experiments on the effect of acute, chronic, and fractionation experiments in *Saintpaulia* was to investigate whether a more efficient mutagenic treatment could be developed. Radiation has a very complex effect on living matter. The energy dissipated in the cells through ionizations is the starting point of a number of chain reactions that interfere with all kinds of metabolic and other processes and ultimately result in permanent physiological and genetic effects, in spite of the generally large repair capacity of the cells of the organism involved.

The physiological effect, for instance, expressed in survival percentage of the irradiated plant parts, obviously depends on a great number of factors, e.g., the radiosensitivity of the plant species, the total dose, the dose rate, the type of radiation, and climatic and other environmental conditions before, during, and after the treatment.

This is also the case with the genetic effect, expressed in mutation frequency, for instance, although the role of environmental conditions is much less obvious and for the greater part unknown. It would be of great importance for the practical plant breeder to have available clear-cut data on the optimal

method of irradiation which induces the highest possible frequency of useful mutants. Since repair of physiological and genetic effects a priori may be the result of partly different processes, it must be possible to separate the two by a proper treatment in such a way that the physiological damage to survival, growth, and fertility as well as the undesirable part of the genetic effect (chromosome aberrations) is minimal, whereas the desired genetic effect (gene mutations, favorable chromosome rearrangements, etc.) is maximal.

The effect of various factors on mutation frequency is mentioned here only very incidentally for various reasons. First, the parameter itself is not so reliable as the two physiological parameters of survival and production. Second, the calculations are not advanced enough at the present time to give a clear-cut picture. Third, such a discussion actually belongs in an article dealing with mutation breeding.

At the moment we can only say that an initial dose also protects against the genetic effect of a second irradiation or series of irradiations, but the protection is not so pronounced as in survival and production. By using these facts, we could obtain a greater number of mutants from a given number of irradiated leaves. This idea will be worked out in greater detail as soon as all data are available.

ACKNOWLEDGMENTS

I wish to thank my colleagues for their contributions in the form of positive discussions. Miss E. van Balen deserves special thanks for her efforts in the mathematical treatment of 10 years' accumulation of data as well as for the large number of figures that had to be made.

REFERENCES

1. C. Broertjes, Dose-Rate Effects in *Saintpaulia*, in *Mutations in Plant Breeding II*, Panel Proceedings, Vienna, 1967, pp. 63-71, International Atomic Energy Agency, Vienna, 1968 (STI/PUB/182).
2. K. H. Chadwick and W. F. Oosterheert, Neutron Spectrometry and Dosimetry in the Subcore Facility of a Swimming Pool Reactor, *Atompraxis*, **15**: 178-180 (1969).
3. E. J. B. Christian et al., Mechanisms of γ -Ray Induced Radioresistance to Early Mortality in the 3-Day Chick, *Radiat. Res.*, **25**: 179 (1965).
4. D. K. Bewley, S. B. Field, R. L. Morgan, B. C. Page, and C. J. Parnell, The Response of Pig Skin to Fractionated Treatments with Fast Neutrons and X Rays, *Brit. J. Radiol.*, **40**(478): 765-770 (1967).
5. J. Denekamp, J. F. Fowler, K. Kragt, C. J. Parnell, and S. B. Field, Recovery and Repopulation in Mouse Skin After Irradiation with Cyclotron Neutrons as Compared with 250-kV X rays or 15-MeV Electrons, *Radiat. Res.*, **29**: 71-84 (1966).
6. M. P. Dacquisto, Acquired Radioresistance. A Review of the Literature and Report of a Confirmatory Experiment, *Radiat. Res.*, **10**: 118-129 (1959).

7. J. Maisin, E. van Duyse, A. Dunjic, J. van der Merckt, A. Wambersie, and D. Werbrouck, Acquired Radioresistance, Radioselection, and Radioadaptation, *Int. J. Rad. Biol., Suppl., Immediate Low Level Effects of Ionizing Radiations*, Symposium Proceedings, Venice, June 22-26, 1959, pp. 183-194, Taylor & Francis Ltd., London, 1960.
8. E. Krokowski and V. Taenzer, Der Radiogene Strahlenschutz Effekt, *Strahlentherapie*, **130**: 139-145 (1966).
9. V. Taenzer and E. Krokowski, Acquired Radioresistance Following Whole Body Irradiation, *Acta Radiol., Ther., Phys., Biol.*, **7**(2): 88-96 (1968).
10. E. Krokowski, Extraregionale Strahlenwirkungen, *Strahlentherapie*, **135**: 193-201 (1968).
11. R. Roy Davies, The Effect of Dose Fractionation on Mutation Induction, *Strahlenwirkung und Milieu*, 160-170, 1962.

SUMMARY OF RESEARCH ON FALLOUT EFFECTS ON CROP PLANTS IN THE FEDERAL REPUBLIC OF GERMANY

HELLMUT GLUBRECHT

Institut für Biophysik der Technischen Universität Hannover and Institut für Strahlen-
botanik der Gesellschaft für Strahlen- und Umweltforschung mbH, München, Germany

ABSTRACT

Two groups of experiments are discussed. The first was concerned with effects of stratospheric fallout with relatively low activities (10^{-9} to 10^{-4} Ci/m²/day). Various species of plants were exposed to continuing artificial ⁸⁹Sr, ⁹⁰Sr, or ¹³⁷Y fallout in special growth chambers. Uptake of the radionuclides by aboveground parts of the plants and by roots could be controlled, and the distribution in various plant organs was checked. Damaging effects could be observed only at activities of at least 10^{-5} Ci/m²/day. At lower fallout activities, however, some parameters (dry mass, plant height, etc.) were significantly increased as compared with the control. In the second group of experiments, the effects of external gamma irradiation were investigated in field experiments with barley, wheat, rye, and potatoes. Irradiation was performed at various stages of development and, on some cereals, also during hibernation. Parallel experiments on chronic exposure of the same crop species were carried out in a small gamma field. The results were in good agreement with data obtained by investigators in other countries. The radiation sensitivities of about 20 of the most common varieties of barley and wheat grown in West Germany were compared. Maximal differences of dose values resulting in the same degree of damage were $\pm 30\%$.

The effects of radioactive fallout on crop plants can be considered under two different points of view:

1. Radioactive contamination of the crop and transfer of radioactivity to man by the food chain.
2. Damaging effects on crop yield by external gamma and beta radiation as well as by radionuclides incorporated into the plants.

It is now well known that, in the event of a nuclear war, the first group of effects would not play an important role as compared with the second group, at least as an acute hazard. The situation was different in the test explosions; cultivated land was reached only by tropospheric and stratospheric fallout,

and long time intervals had to be considered. In this case the fission products were soluble in water to a considerable degree, and long-lived radionuclides like ^{90}Sr and ^{137}Cs played a role.

In the acute situation after detonation of an atomic bomb, the fallout components would be insoluble, and incorporation into plants would be negligible. However, stratospheric fallout would occur after some time, and then the hazards for areas far from the place of detonation of the nuclear explosions would have to be considered.

In this paper two sets of experiments concerned with these two different situations are described. Nearly all the data given here are from our laboratory.

EFFECTS OF SIMULATED STRATOSPHERIC FALLOUT ON PLANTS

Experiments of this type were performed in our laboratory first by Niemann,¹ later by Naghedi-Ahmadi,² and most recently by Elmdust and Nassery.³ Basic data were derived from the maximal beta activity of fallout measured in West Germany, A_0 , which was $3.7 \text{ nCi/m}^2/\text{day}$. The activity of fallout solutions was given in multiples of A_0 .

The plants were grown under controlled conditions in glass boxes, and the fallout solution was sprayed on them daily by an automatic device (Fig. 1). The plants investigated in these experiments were:

1. *Lolium multiflorum* Lam., as model of a pasture grass.
2. *Arabidopsis thaliana* (L.) Heynh., for research on more than one generation.
3. *Kalanchoe blosfeldiana*, for long-time studies on vegetatively propagated plants.

The ^{90}Sr , ^{89}Sr , and ^{131}I were applied as SrCl_2 and NaI in carrier-free solutions. Controls were treated with stable strontium and iodine.

In Germany in 1963 the maximal concentration values of ^{90}Sr which had been observed were within 13% of the recommendations of the International Commission on Radiological Protection. The first question to be answered by our experiments was: Will the activity in the plants be increased proportionally at fallout activities of 10 to $10^6 A_0$? The answer is clearly "no" because:

1. The radionuclides are taken up mainly by aboveground parts of the plants. This leads to saturation after a rather short time (Figs. 2 and 3). For ^{131}I the saturation values are less than proportional to the fallout activity (Fig. 4).
2. Only 10 to 20% of the activity will be incorporated by the plants. If 20% of the soil surface is covered by plants, the total uptake is of the order of 2 to 4%. This percentage becomes lower for fallout activities greater than $10^5 A_0$.



Fig. 1 Experimental device for treatment of plants with artificial fallout.

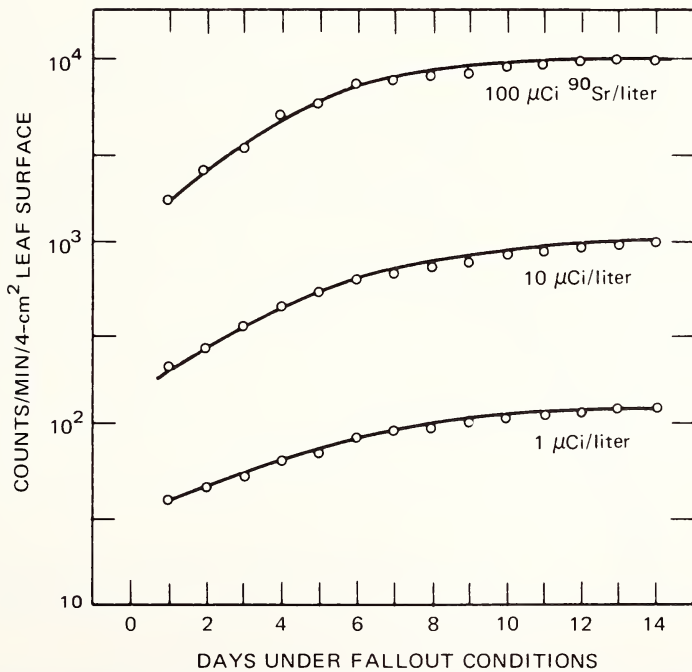

Fig. 2 ^{90}Sr content of growing leaves of *Lolium multiflorum* Lam. at daily ^{90}Sr fallout.

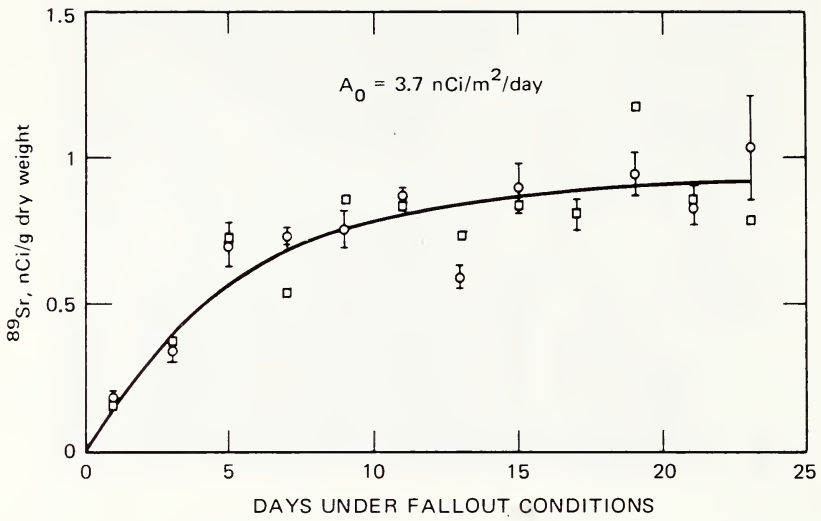

Fig. 3 ^{89}Sr contamination in rosette leaves of *Arabidopsis thaliana* (L.) Heynh. at various fallout concentrations. \circ , $5 \times 10^4 A_0$; \square , $5 \times 10^2 A_0$.

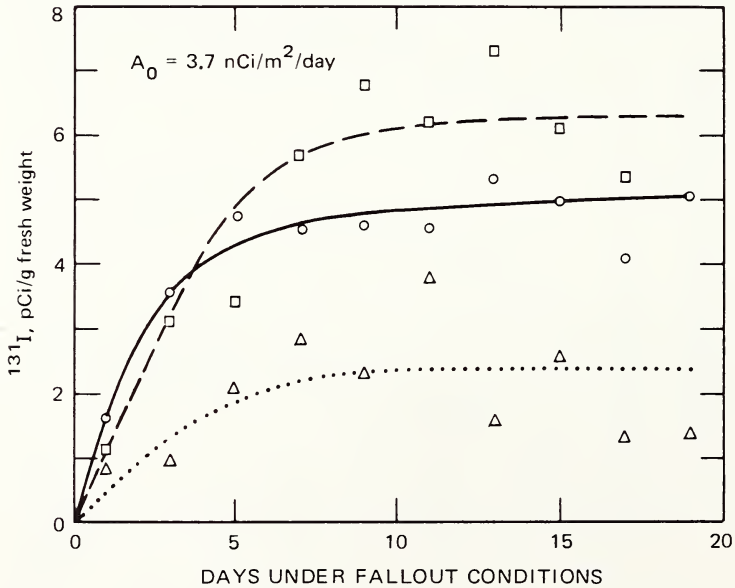

Fig. 4 ^{131}I contamination in leaves of *Kalanchoe blotsfeldiana* at various fallout concentrations. \circ —, $10^4 A_0$; \square —, $10^2 A_0$; Δ —, A_0 .

Therefore the main hazard of stratospheric fallout would be the continuous contamination of the soil. But uptake of long-lived radionuclides like ^{90}Sr and ^{137}Cs would be limited by the reduced availability of these ions after they are absorbed in the soil.⁴

The next question concerned damaging actions of the radioactivity incorporated in the plants. Radiation effects were observed at very low activities, as shown in Fig. 5, with the example of the flowering date of *Arabidopsis*. But these effects had the character of "stimulation." Other end points were influenced in a similar way; e.g., dry weight was 135% of control values at $50 A_0$ of ^{90}Sr . A good example of stimulation effects can be seen in Fig. 6, which shows control and treated *Kalanchoe*.

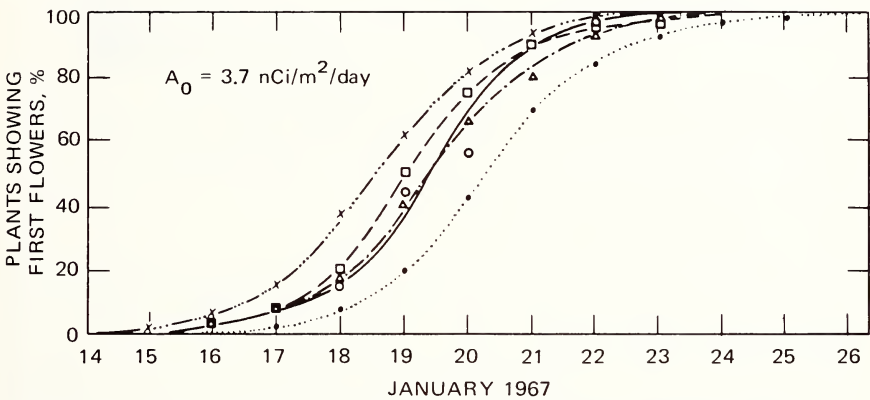

Fig. 5 Effect of ^{90}Sr fallout on first flower formation of *Arabidopsis thaliana* (L.) Heynh. $\cdots\bullet\cdots$, control; $\cdots\text{x}\cdots$, $5 A_0$ ^{90}Sr ; $-\Delta-$, $50 A_0$ ^{90}Sr ; $-\square-$, $5 \times 10^2 A_0$ ^{90}Sr ; $-\circ-$, $5 \times 10^3 A_0$ ^{90}Sr .

Damaging effects were never observed at fallout activities lower than $10^5 A_0$, which corresponds to $370 \mu\text{Ci}/\text{m}^2/\text{day}$. After 1 year $135 \text{ mCi}/\text{m}^2$ would be accumulated in the upper layers of the soil. Since in actuality ^{137}Cs would be a component of stratospheric fallout in roughly the same concentration as ^{90}Sr , the annual dose at 1 m above the soil surface may amount to about 10 krad. Therefore, as far as damaging effects on crop plants are concerned, the external radiation cannot be neglected even in the case of stratospheric fallout.

EFFECTS OF EXTERNAL GAMMA IRRADIATION ON CROP PLANTS

In the situation discussed in the foregoing paragraph, external irradiation by fallout residues would be of the character of chronic irradiation. After a nuclear explosion the local fallout would act more like acute irradiation. The simulation



Fig. 6 *Kalanchoe blofeldiana* exposed to ^{90}Sr fallout. Right, control treated with inactive strontium (5×10^{-7} g Sr/liter); left, fallout activity $5 A_0 = 1.85 \times 10^{-8}$ Ci $^{90}\text{Sr}/\text{m}^2/\text{day}$.

of the $t^{-1.2}$ decay of early fission products has been achieved by Sparrow and co-workers.⁵ According to their results reasonable data can also be obtained by constant-rate irradiation for 16 hr.

We started experiments with chronic and acute irradiation of cereals—wheat, barley, rye—to obtain data on crops cultivated under natural conditions in our climate and to investigate the influence of various stages of development on radiation sensitivity. The acute irradiation time was 8 hr for all doses.

The chronic irradiation was performed in a small gamma field with a 10-Ci ^{137}Cs source. For acute irradiation a portable 300-kV X-ray machine was used. Dose variation was achieved in both cases by varying the distances between radiation source and plants. The stages of irradiation were:

1. Two-leaf stage.
2. Four-leaf stage.
3. Posttillering.
4. Ear emergence.
5. Anthesis.

Three repetitions were provided for each experiment, and the same experiment was repeated the following year. The varying climatic conditions in different years had surprisingly little influence.

The variation of radiation sensitivity at different stages was as striking as that observed by other investigators in pot experiments. One example of dose-effect curves is given in Fig. 7. Maximal sensitivity was always reached in either stage 3 or 4.

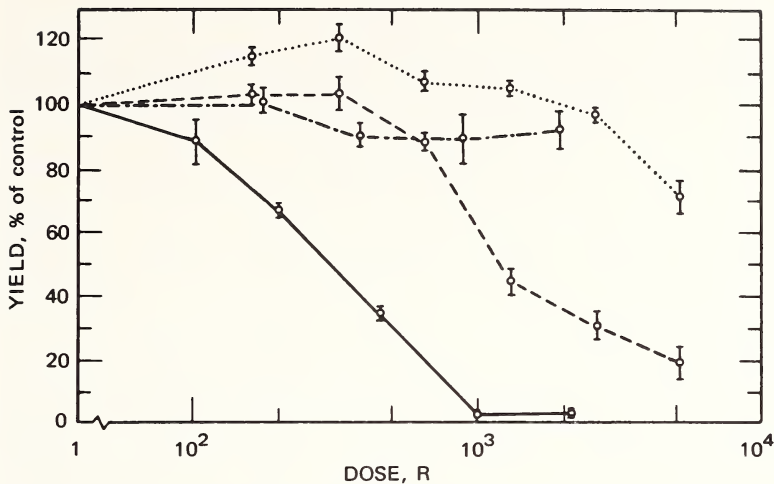

Fig. 7 Effect of acute X irradiation at various stages of growth on the seed yield of winter wheat., four-leaf stage; ----, posttillering; —, ear emergence; -.-.-, anthesis. Yield of controls is 100%.

Average exposures reducing grain yield to 50% of control are shown in Table 1 for chronic and acute irradiation of three species of cereals. Grain yield is related to unit area, i.e., to a constant number of seeds. The difference between summer and winter varieties was very surprising. Winter wheat and winter rye have extremely high sensitivity at ear emergence. The summer crops, however, are more sensitive at the posttillering stage, the total dose applied during chronic irradiation being at least three times higher than the acute dose. The winter varieties were exposed to chronic irradiation throughout the whole time from sowing to harvest. Therefore the factor of difference here is considerably higher.

During the winter the cereals are apparently rather resistant to irradiation, but temperature seems to play a small role compared with the stage of development. In one experiment irradiation of winter wheat during the two-leaf stage had to be performed at -3°C in late February; in the other year it was in early April at 15°C . The dose values for equal effects were only 10% lower in the latter case.

Different varieties of one species may vary in radiation sensitivity. It would be valuable to have especially resistant varieties. Greenhouse experiments have been made with 16 varieties of summer wheat grown in Germany. Irradiation was performed in the one-leaf stage (8 cm) with four dose values. After 8 weeks, plant height, dry mass, and number of tillers were checked. There was no deviation of more than 30% from the average values of all 16 varieties. The best way to avoid losses in crop yields in the case of a nuclear war seems to be to grow less-sensitive species.

Table 1

AVERAGE EXPOSURE VALUES FOR 50% REDUCTION OF GRAIN YIELD OF VARIOUS CEREALS RECEIVING ACUTE IRRADIATION AT DIFFERENT STAGES OF DEVELOPMENT OR CHRONIC IRRADIATION

Crop species	Acute irradiation, R					Chronic irradiation (total dose), R
	Two-leaf stage	Four-leaf stage	Posttillering	Ear emergence	Anthesis	
Summer barley						
Breuns wisa	5000	3000	1000	1500	3000	3000
Summer wheat						
Opal	5000	4500	1300	1600	3000	3500
Winter wheat						
Jubilar	5000	5000	1200	400	5000	3500
Winter rye						
Petkuser	4000	3500	400	300	1500	2400

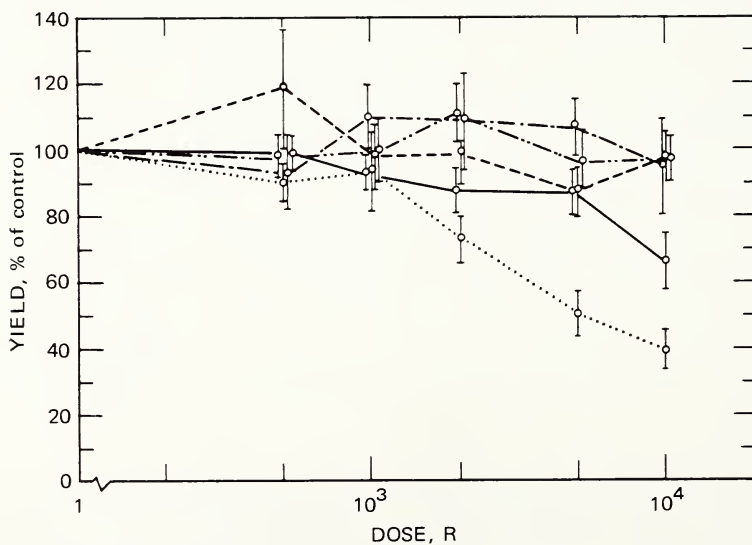

Fig. 8 Effect of chronic gamma irradiation at various stages of growth on the yield of potatoes., germination (May 22-June 12); ---, start of anthesis (June 12-July 1); -·-·, end of anthesis (July 1-20); - - - -, yellow stage (July 20-Aug. 9); —, ripening (Aug. 9-29).

In this regard some results of Keppel⁶ with potatoes should be mentioned. He simulated fallout radiation by spreading ⁶⁰Co beads on the soil between the plants. The vegetative period was divided into five periods of about 3 weeks each, during which chronic irradiation was applied. Only the germination stage seemed to be sensitive in the dose range below 10,000 rads (Fig. 8).

Much more data are needed for a complete evaluation of the problems of damage in crop plants in the case of a nuclear war, but basic research on the mechanisms of different radiosensitivities should not be neglected.

REFERENCES

1. E. -G. Niemann, Wirkung eines künstlichen ⁹⁰Sr-Fallout auf Pflanzen, *Atompraxis*, **7**: 370-375 (1961); also **8**: 51-60 (1962).
2. J. Naghedi-Ahmadi, Über die Wirkung aus dem Fallout inkorporierter Radionuklide in Pflanzen, Thesis, Technischen Universität Hannover, Germany, 1967.
3. M. Elmdust and T. Nassery, Technischen Universität Hannover, unpublished data.
4. R. Scott Russell, Dietary Contamination, Its Significance in an Emergency, in Radiological Protection of the Public in a Nuclear Mass Disaster, H. Brunner and S. Pretre (Eds.), Proceedings of a Symposium, Interlaken, Switzerland, May 26-June 1, 1968, Report CONF-680507, pp. 279-306, Fachverband fuer Strahlenschutz e.V., 1968.
5. A. H. Sparrow, Brenda Floyd, and P. J. Bottino, Effects of Simulated Radioactive Fallout Buildup and Decay on Survival and Yield of Lettuce, Maize, Radish, Squash, and Tomato, *Radiat. Bot.*, **10**: 445-455 (1970).
6. H. Keppel, in Forschung im Geschäftsbereich des BML, Annual Report, Part Q, pp. 125-126, Bonn, 1969.

RADIATION DOSES TO VEGETATION FROM CLOSE-IN FALLOUT AT PROJECT SCHOONER

W. A. RHOADS,* H. L. RAGSDALE,† R. B. PLATT,† and E. M. ROMNEY‡

*EG&G, Inc., Santa Barbara Division, Goleta, California;

†Emory University, Atlanta, Georgia; and ‡University of California,

Laboratory of Nuclear Medicine and Radiation Biology, Los Angeles, California

ABSTRACT

Project Schooner was a nuclear cratering experiment in the Plowshare Program for peaceful application of nuclear explosives. On the basis of information from two earlier experiments, Palanquin and Cabriolet, special dosimeters for measuring both beta and gamma radiation were placed in the open environment and on shrubs in the downwind area where fallout was anticipated. In addition, polyethylene sheets were placed over some shrubs to determine whether the shrubs could thus be protected against radiation damage. The gamma radiation doses for shrubs not covered were found to be essentially the same as the doses measured in the open and away from shrubs, but there was a 15% reduction in dose under the sheets. The beta doses to unsheltered vegetation were, however, reduced by almost 50% compared with doses at 25 cm in the open. This reduction was attributed to self-shielding. Beta doses to the shrubs were reduced still further, to 31% of the 25-cm beta dose in the open, by shielding the shrubs from direct fallout contamination. The estimated LD₅₀ for *Artemisia* was 4449 rads, but the reduction in dose by the shelters was nearly sufficient to prevent damage to the shrubs, even though all other *Artemisia* shrubs in the center of the fallout pattern were killed. It was concluded that beta doses must be considered in protecting growing food crops and livestock and that even minimal shelter to prevent direct surface contamination would be of great importance.

Project Schooner was a nuclear experiment in a layered tuffaceous medium, executed as a part of the Plowshare program for development of nuclear excavation. Detonation occurred Dec. 8, 1968, at 0800 (PST) in Area 20 of the Nevada Test Site (NTS). The resultant yield was 31 ± 4 kt (Ref. 1). Other details are published elsewhere. This paper is concerned only with radiation doses and their effects on vegetation along an arc of dosimetry stations approximately 1800 m from ground zero (GZ).

The vegetation in the area is dominated by *Artemisia arbuscula* and *Artemisia tridentata*, two species of the sagebrush which hybridize. *A. tridentata* was of primary interest at Schooner. Unfortunately, the junipers, which were of interest in the earlier studies at Palanquin and Cabriole, ^{2,3} did not occur in the immediate downwind region of Schooner. Several other shrubs did occur, but only sporadically, and therefore were of little importance to this study. *Artemisia* has been previously shown to be a relatively sensitive shrub having an LD₁₀₀ around 5500 rads (Ref. 3). Its occurrence in widespread and relatively pure stands makes it a good plant for use in the investigation of radiation effects.

As background we will mention some results of two earlier experiments, Palanquin and Cabriole, in the same geographical area. From Palanquin, ² the first of these experiments, it was concluded that the vegetation damage was caused by radiation, probably mostly beta since the gamma-ray doses in much of the area, insofar as they could be derived, were too low to account for the extent of the damage. Another important result observed at Palanquin was the asymmetrical distribution of shrub damage, a damage pattern noted earlier in the Yucca Flat area of NTS by Shields and Wells. ⁴ In the areas peripheral to those where all or most plants were killed, this pattern of damage was a common characteristic; i.e., the plants were extensively damaged across the sides of the shrub toward GZ in the direction from which the fallout material was carried by the wind. In extreme cases only small branches or twigs remained alive; in other cases protection from rocks or larger shrubs and small trees sheltered whole plants from damage.

At Cabriole, ³ the second experiment of interest preceding Schooner, an extensive dosimetry program was undertaken to measure both beta and gamma-ray doses to the environment and to the vegetation. The special dosimetry designed by Kantz and Humpherys ³ for this program provided what appears to be the first opportunity to make comprehensive measurements in a field environment.

Dose measurements were made by placing dosimeters in the open away from vegetation, on the fronts, tops, sides, and backs of shrubs and phantom plants. Some of the dose data from this experiment were presented by Kantz ⁵ earlier in this symposium.

The vegetation at Cabriole showed a pattern of damage like that observed at Palanquin—the fronts of the shrubs were often damaged seriously, and, near the middle of the pattern, the *Artemisia* were entirely killed. This coincided with the pattern of doses, more particularly beta doses, observed there. It was concluded from this experiment that there was sufficient support for the hypothesis that beta radiation was primarily the cause of damage to the vegetation. This does not mean that gamma-ray doses were not important, however, since the two doses are additive.

Both the Palanquin and Cabriole devices were very small, less than 5 kt. The dosimetry stations were placed relatively close to GZ (at Cabriole, about 610 m away) to ensure that the doses would be sufficiently great to be of interest. At

that distance the killed *Artemisia* covered a segment of the arc less than 150 m long.

At Schooner, where the yield was relatively much greater, there was an opportunity to look at a larger irradiated area located in different terrain. The vegetation was also different although *Artemisia* remained the dominant species. In addition, Schooner presented an opportunity to test the hypothesis that, if beta radiation were a primary cause of damage to vegetation, then sheltering the vegetation from fallout should provide important protection.

METHODS

Fallout Dosimetry Stations

Dosimeters were located at 97 stations along an arc north and east of the proposed GZ at distances from 1700 to more than 2000 m. Figure 1 shows the locations of the stations with respect to GZ and the terrain features important to this study. Referring to the aerial photograph of the area shown in Fig. 2, we can relate the size of the crater to the doses to the environment and to the effects of those doses. The solid lines in Fig. 1 indicate the boundaries of the canyon in which the dosimetry stations were located. The bottom of the canyon was 30 to 100 m below the level of the land toward GZ and somewhat lower still than part of the area beyond the canyon. A combination of geography and the anticipated distances to which the base surge from the detonation was expected to reach determined the location of the stations. Although at the beginning of this experiment this very remote area of NTS was virtually without roads, trails, or other conventional landmarks, it was possible to enter the area with four-wheel-drive vehicles.

The distance covered by the arc of stations shown in Fig. 1 was about 2.8 km, and the distance between stations was approximately 35 m. These stations were placed in position 3 weeks before Schooner. At the same time, dosimeters that had been given measured doses were placed in the field as a check on dosimeter fading. One set of these dosimeters was removed from the field on D day, and another was removed when the dosimeters were collected from the fallout pattern. These provided tests both for accumulation of doses attributable to possible radiation from unknown sources and for dose fading due to sunlight and temperatures in the desert environment. No loss or increase in doses was observed from these dosimeter checks.

Vegetation Shelters and Dosimetry

In addition to the dosimeters placed in vertical arrays, four dosimeters were placed on sheltered shrubs and four on shrubs in the open. In each case one dosimeter was placed on the front (toward GZ) and one on the back of the shrub. Attempts were made to place the dosimeters on symmetrical shrubs that

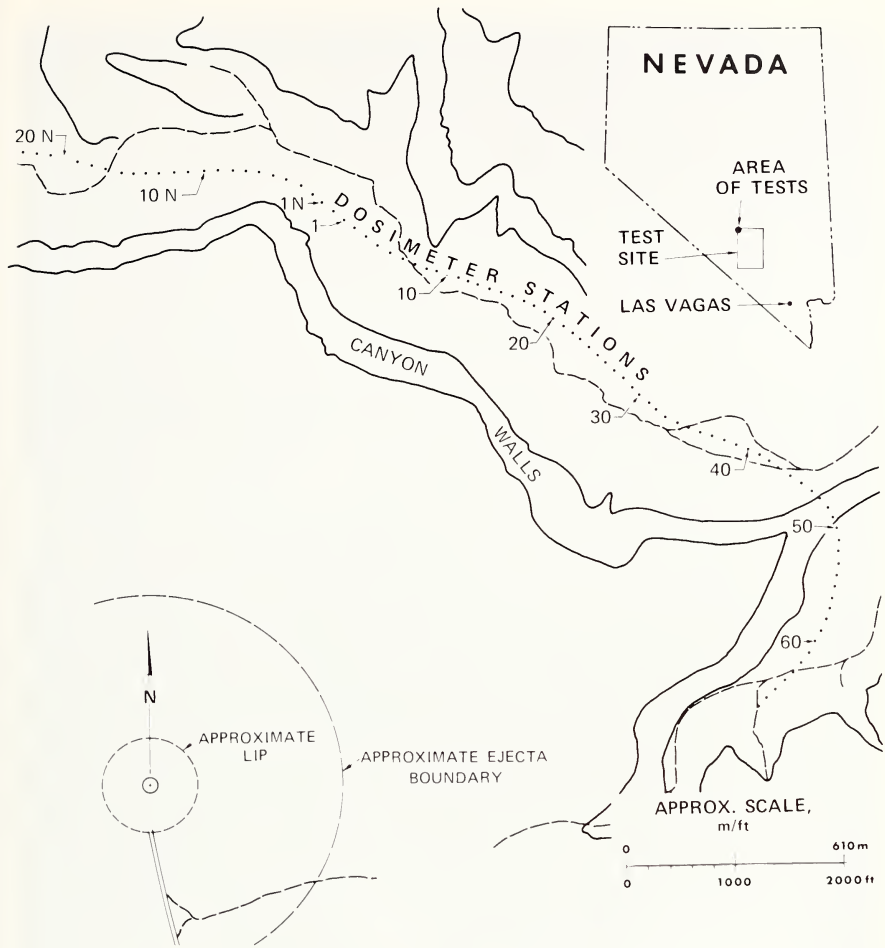

Fig. 1 Schooner crater and the location of the dosimetry stations to the north and east of it.

were not close to other shrubs. Generally, this was not possible among the sheltered shrubs, because of the limited numbers available.

Polyethylene sheets 6 m square and 6 mils thick were spread over as many *Artemisia* shrubs as could be covered conveniently at alternate stations along the arc. Figure 3 shows a protective sheet in place and also provides a general view of the terrain and vegetation.

Fallout from Schooner occurred to the north and northeast of GZ. The dosimeter stations were within the edge of the base surge at the north but were

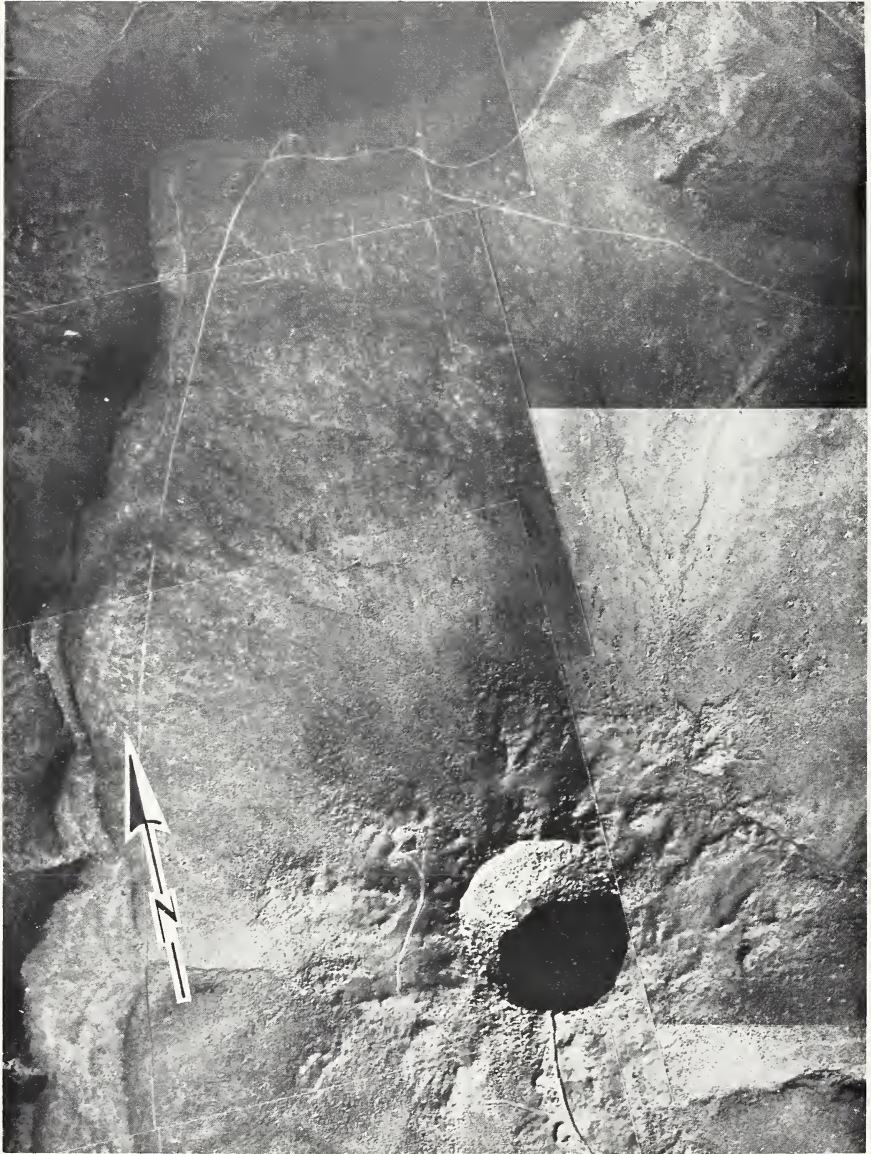

Fig. 2 Aerial photograph of the Schooner area. The point at which the trail in the upper part of the photograph dead-ends at the cliff is the approximate center of the primary local fallout pattern. Station 6N is in the bottom of the canyon below that point.



Fig. 3 Station 12N, showing a part of a 6-m-square polyethylene sheet in place over *Artemisia* shrubs. The stakes at the right of the covered shrubs mark the locations of dosimeter stations, the dosimeters being held on vertical wires. The point of the cliff in upper center is that shown in Fig. 2 where the trail dead-ends. The vegetation is typical *Artemisia tridentata*.

less so to the east. Some areas received an estimated fallout of up to 300 g/m^2 . Others received relatively little.

On Dec. 20, 1968, at D + 12 days, all dosimeters were removed from the field and the shrubs were uncovered. At this time no differences were observed between the shrubs that were covered and those left exposed, except that those exposed were very dusty.

Some of the polyethylene sheets were torn by heavy winds, but this damage was not severe except directly east of Schooner GZ at the mouth of the canyon, where, fortunately, the doses were too low to be of interest. At this time patches of snow, which had fallen about D + 7 days, still remained, and sometimes ice and snow mixed with fallout had to be removed along with the polyethylene sheets.

All dosimeters were returned to the laboratory for readout on D + 23 days. Reading of the dosimeters began on D + 29 days.

RESULTS

Gamma-Ray Doses and Data on Radiological Safety Monitoring

Figure 4 shows the dose rates at each dosimeter station as read from conventional instruments for radiological safety monitoring as the dosimeters were removed from the field. Also shown for comparison are the gamma-ray doses measured by the dosimeters at 1 m. The purpose of the comparison is to illustrate that postevent safety monitoring may not provide an adequate basis for dose estimates. If field doses were calculated from the safety monitoring dose-rate data by multiplying by some systematic factor, there would be a considerable discrepancy between the estimated and the measured doses. That the curves are not parallel is probably attributable to continued deposition and redistribution after the initial deposit of early postdetonation material with its resultant high infinite dose.

Radiation Doses 25 Cm Above the Soil Surface

Radiation doses were measured 25 cm above the soil surface since this was judged to be a height at which doses appeared to have the greatest effect on the local vegetation. Dose measurements were also made at the soil surface, but these varied widely because surface irregularities caused the fallout material to accumulate nonuniformly. This was particularly apparent in the reading of the beta doses since they were derived much more from sources near the irradiated object than were gamma-ray doses. This is because gamma-ray doses accrue from relatively large areas, whereas beta doses are affected primarily by particles on and nearby the surface of the irradiated objects.

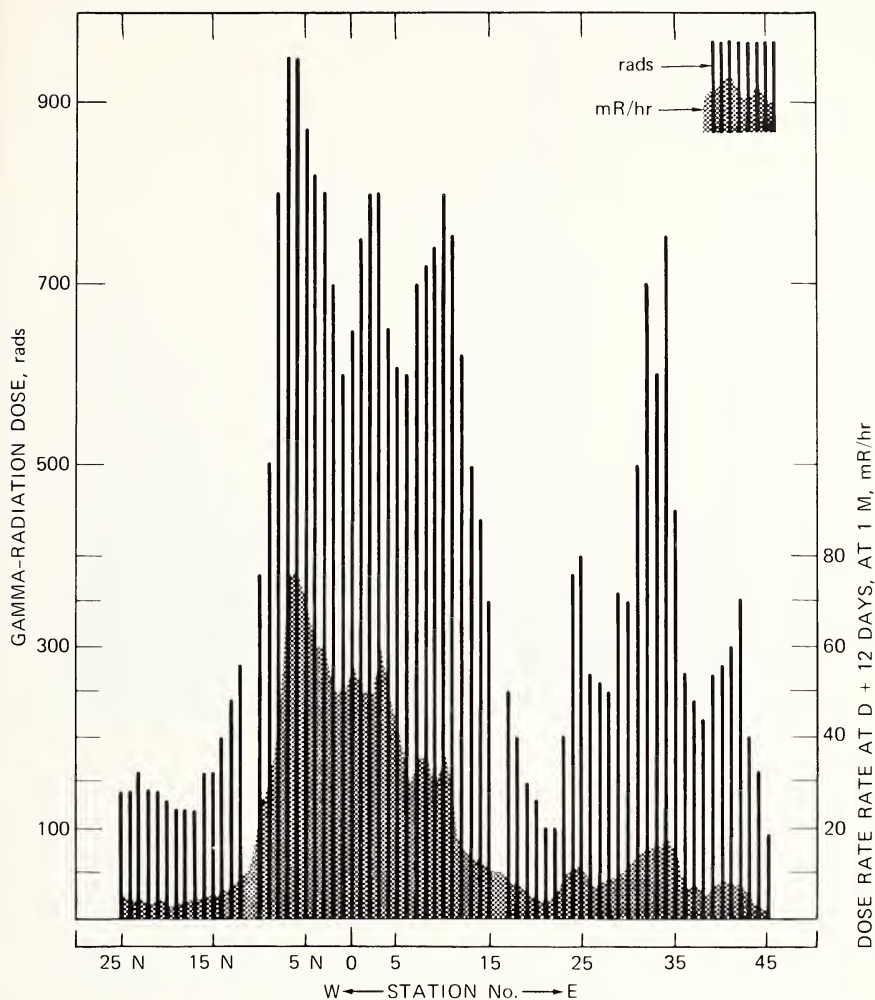

Fig. 4 A comparison of the gamma-ray doses from dosimeters at 1 m and the dose rates taken by conventional radiological safety monitoring on D + 12 days.

The gamma-ray doses at 25 cm were essentially the same as those for 1 m (Fig. 4). The beta doses measured 25 cm aboveground by dosimeters placed on vertical wires away from vegetation are shown in Fig. 5.

Figure 6 shows the ratios of the beta to gamma-ray doses obtained from these measurements. Two characteristics of these data are of interest. First, there appears to have been a systematic fluctuation in the dose ratio. Such a fluctuation was also observed at Cabriole. The recurrence of this fluctuation is

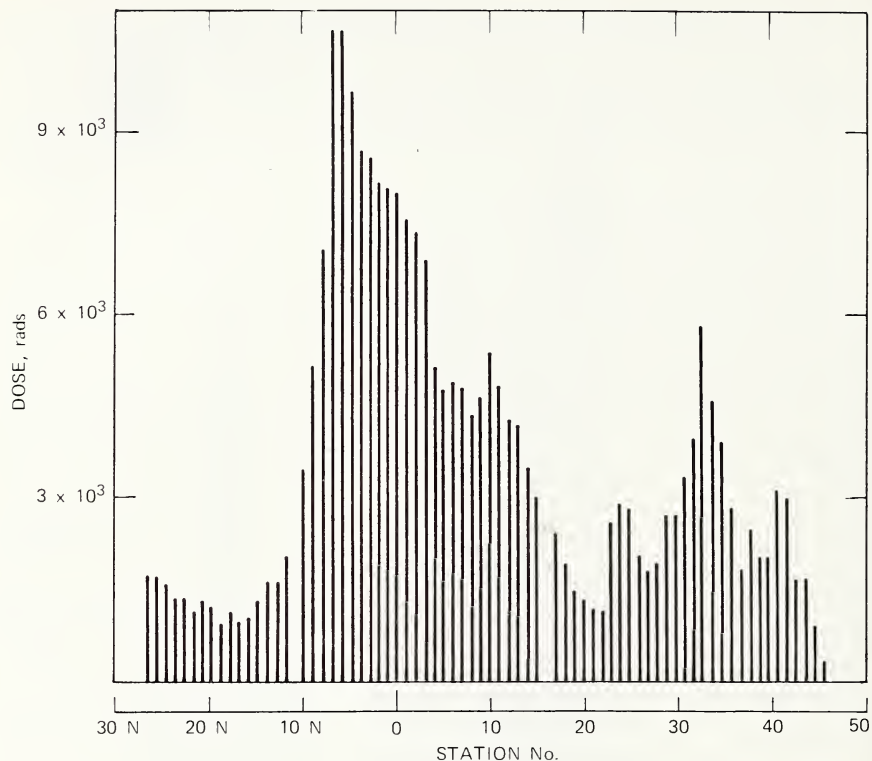

Fig. 5 The beta radiation doses (in rads) measured at 25 cm above the soil surface in the fallout pattern of Schooner.

probably more than chance; but, to be more than speculation, its explanation must come from those who design and execute the experiments. Second, the dose ratios are large, ranging from 5 to more than 14. Moreover, these ratios are slightly larger than those noted at Cabriolet, which ranged from 4 to 12.5. This difference may be due to an overestimate of gamma-ray doses at Cabriolet, or it may be due to differences in the source of the radioactive debris, i.e., in the device itself; discussion of the device is, of course, beyond the scope of this work.

Doses to the Vegetation

Gamma-Ray Doses

Table 1 shows the doses for the main part of the central peak of radiation across the fallout pattern. Although there are differences at some stations between the gamma-ray doses at 25 cm and those measured on the shrubs, the

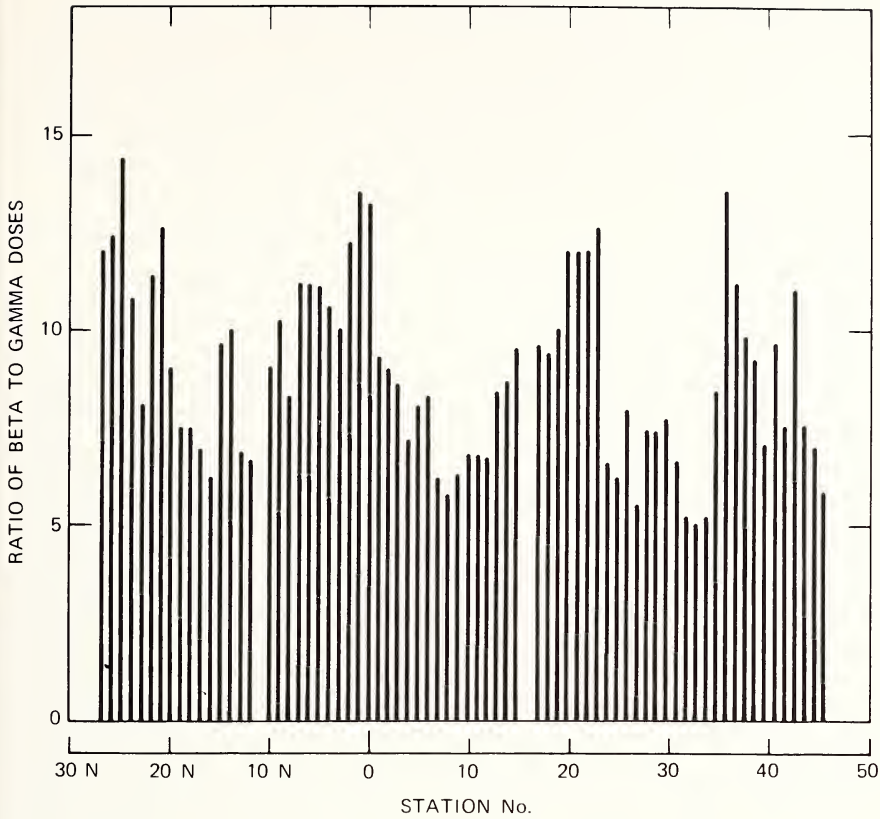

Fig. 6 The ratios of beta- to gamma-radiation doses (both in rads) in the Schooner fallout pattern.

mean difference is essentially zero. The difference between the gamma doses at 25 cm and those measured on the shrubs protected by the plastic sheets is 15%, however. This reduction might be anticipated considering the possibility of a low-energy gamma-ray component of the early postdetonation radioactive debris.

Beta Doses

The beta-dose data shown in Table 1, unlike the gamma-ray-dose data, indicate a reduction in the beta doses to the vegetation compared with the doses measured at 25 cm and away from the vegetation. In addition, the protection of the plastic sheets reduced the beta doses to the shrubs still further. Both reductions were large compared with the gamma-ray-dose reduction and were of important biological significance, as is shown subsequently.

Table 1
DOSE ACROSS THE MAIN FALLOUT PATTERN AT 25 CM ABOVE THE SOIL SURFACE AND TO SHRUBS

Station No.	Dose at 25 cm	Gamma-ray dose, rads				Beta-ray dose, rads				Percent of 25-cm dose		
		Shrub		Open†		Shrub		Open		Open	Covered	
		Open*	Covered	Open*	Covered	Open	Covered	Open	Covered			
12N	280		255		91		2100		1110	630	52	30
10N	380	420	350	+11	92		3420		2160	1590	63	46
8N	800	810	770	+2	96		7800		3000	2190	39	28
6N	950	1060	800	+11	84		10650		5250	3000	49	28
4N	820		710		86		8640		4140	3270	48	38
2N	700	640	610	-9	87		8100		3900	2100	48	26
0	650	680	470	+5	72		7050		3000	2340	43	33
2	800	750	660	-6	83		7500		2910	1770	39	24
4	650	660	480	+2	74		5550		2250	1650	41	30
6	600	590	600	-2	100		4650		2340	1650	51	36
8	720	700	600	-3	83		5040		3240	2040	64	40
10	800	850	530	+6	66		5400		3600	1560	67	29
12	620	580	550	-6	89		4450		2190	900	49	20
14	440		370		84		3480		1620	900	47	26
16	300	‡	260	‡	87				1650	570		
18	200	210	200	+5	100		2100		1500	540	71	26
20	130	120	80	-8	62		1410		990	570	70	39
			Mean	+0.5	84.5						52.6	31.2
			Standard deviation	±5.7	±10.8						±10.9	±6.9

* Only doses differing from the 25-cm doses are shown.

† Percent differences from the 25-cm doses.

‡ Dosimeter not recovered.

The decrease to 52.6% in shrub doses is attributed to "self-shielding," which can be envisioned in terms of the masses of vegetation shadowing themselves. Shrubs that were protected from the direct fallout contamination showed even larger reductions in beta doses, however. For the stations shown in Table 1, the covered shrubs received only 31.2% of the beta dose at 25 cm in the open and away from shrubs.

Effects on the Vegetation

The vegetation along the arc of dosimetry stations was examined at biweekly intervals for a period of 6 weeks after the dosimeters were taken from the field; thereafter it was examined at less frequent intervals. No differences between irradiated and nonirradiated vegetation were detectable until late April when an absence of inflorescence development was first noted. As was previously observed at Cabriole, the first evidence that *Artemisia* had been affected could be seen only by a careful comparison of the nonirradiated with the irradiated shrubs.

Experience has shown that a conspicuous characteristic of *Artemisia* is the occurrence of primordial inflorescences at the beginning of the active growing season, even though *Artemisia* does not come to anthesis until September in the test area. The leaf-color changes that appeared in mid-May and other phenotypic characteristics that, foretold complete defoliation and apparent death by September were not evident beforehand.

By the end of June (D + 7 months), all the damage characteristics previously noted at Cabriole were also apparent at Schooner in the most heavily irradiated parts of the fallout pattern. There were also notable differences, which will be discussed later.

Protected and Unprotected Shrubs

During the months of July and August, two surveys were made of the vegetation along the arc of the dosimeter stations. These surveys revealed that all *Artemisia* shrubs at Stations 4N, 6N, and 7N were killed, with the exception of those shrubs which had been covered with the plastic sheets. There was no damage to covered shrubs except at Station 6N, where four of the six shrubs covered had no damage and two had a small amount of defoliation. At all stations, 8N to 4 inclusively, around the arc, half or more of the uncovered *Artemisia* shrubs were 50 to 100% defoliated. Lesser damage was observed over many other stations.

A 9-month LD₅₀ was derived from the August survey. The survey included all *Artemisia* shrubs within a 5-m radius of each dosimeter-support post. Eleven stations from 12N eastward to Station 13 were surveyed; only those stations at which either all or none of the *Artemisia* had been killed were excluded. The shrubs were grouped into two categories: (1) yellow brown to dark gray and

dead or (2) gray green and living. Plants on the end of the radii with more than half their diameter beyond the 5-m limit were omitted. Those with more than half their diameter within the radii were counted. These counts were then used to determine the LD_{50} by probit analysis. Data were determined from all stations even though half the stations did not have shrub doses determined by dosimeters on the shrubs. As shown in Fig. 7, the LD_{50} was 7760 rads. When

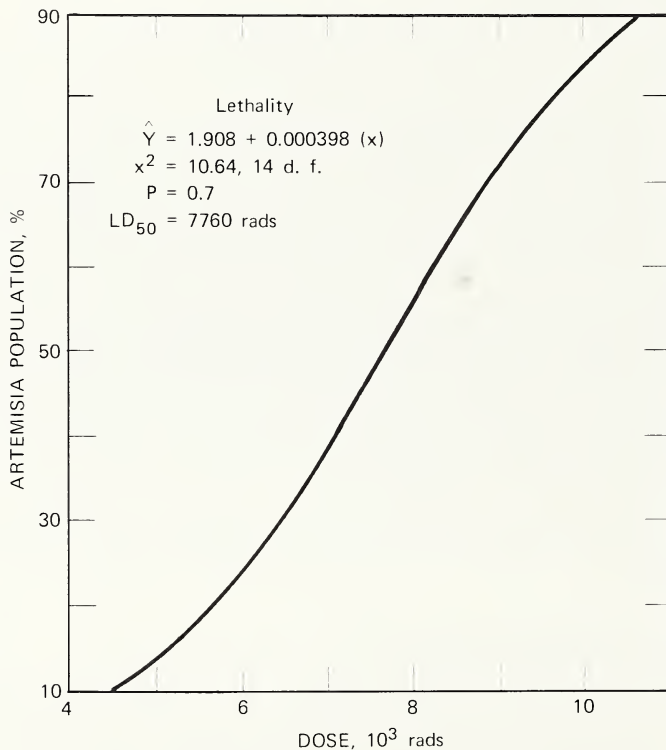

Fig. 7 The LD_{50} for *Artemisia* as of August 1969, 8 to 9 months postevent. The dose, reduced for the self-shielding factor, is 4449 rads.

the beta dose is corrected by the factor 0.526 from Table 1, the dose becomes 4449 rads if, from Fig. 6, the beta-to-gamma ratio is assumed to be 10. It was not possible to derive an LD_{50} with equal precision at Cabrioleet, but an LD_{100} for Cabrioleet is nearly identical to the LD_{100} for Schooner when the value for Schooner from the 25-cm dose is reduced by the self-shielding factor. Both values are 5500 rads.

Comparison of Sublethal Damage with That at Cabriole

In the peripheral parts of the fallout patterns of both Palanquin and Cabriole, defoliation occurred in a characteristic pattern;^{2,3} i.e., the sides of the shrubs toward GZ and the tops of the shrubs were injured, but the backs remained relatively undamaged. At Schooner, however, along the arc of dosimeter stations, this pattern occurred infrequently, and another kind of damage pattern was observed. The lower twigs and branches all the way around the shrub were likely to be defoliated. An example of this is shown in Fig. 8, a photograph taken at D + 9 months. The extent of the damage appeared to be correlated with the dose, and, in extreme cases at higher doses, only a few branches or even a single branch remained alive. There were other patterns of damage also, but this was the most frequently encountered. The developing inflorescences that are approaching flowering can be seen at the top of the shrub. Yet the entire bottom half of the shrub is without leaves. The photograph was made at Station 32, where the shrubs recorded a dose of 3150 rads of beta and 700 rads of gamma radiation.

CONCLUSIONS AND DISCUSSION

Dose Reduction by Self-Shielding and Terrain

At Schooner no consistent differences were detectable between the gamma-ray doses received by the shrubs and those measured on the vertical-array dosimeters away from the shrubs. This was also the case at Cabriole.

The relatively large reduction in beta-radiation dose to the vegetation compared with the 25-cm dose appears, however, to be higher than that observed at Cabriole. Although doses were measured on both fronts and backs of the shrubs at Schooner also, it was not possible to distinguish a difference between these doses. This was quite unlike the circumstances at Cabriole, where the fronts of the shrubs received larger doses than the backs. These dose differences are summarized in Table 2. There are several speculative explanations for these differences which may contribute to the better understanding of damage from fallout.

Cabriole fallout occurred across the front and sides of a low hill without a significant increase in elevation between the crater and the hottest part of the fallout pattern. At Schooner the vegetation was in the bottom of a canyon where the *Artemisia* shrubs were generally larger than those at Cabriole. They also appeared to occur in relatively larger clumps with possibly more open space between them. These characteristics are attributable to the differences in the phenology and pedology encountered on the shallow soils of the exposed hillside compared with conditions on the alluvial bottoms of the canyons.

It seems evident that fallout deposition varied as a result of terrain differences. On the exposed hillsides, where there were moderate winds,



Fig. 8 An *Artemisia* shrub about 1 m high, the lower one-half of which has been defoliated. The top is relatively normal, although there may be a reduction in the number of inflorescences.

Table 2
PERCENT BETA-DOSE REDUCTION
FROM THE 25-cm DOSE

	Means of fronts, tops,* and backs	Backs only
Schoonert†	-47.4	-47.4
Cabriolet‡	-18.4 ± 11.3	-32.7 ± 13.1

*Doses were not measured in the tops of shrubs at Schooner.

†From the values in Table 1.

‡Means and standard deviation³ for Stations 1 to 7.

differences in front to back were expected and were measured. (Differential deposition of airborne volcanic dust was noted by Miller.⁶) At Schooner, where the wind direction was essentially at a right angle to the canyon, the wind-borne fallout apparently was not deposited differentially from front to back of shrubs, and, as a result, no dose differences were distinguishable.

The Cabriolet shrubs, which were subjected to winds in an open, exposed location, appear to have stopped more fallout than was deposited nearby, when compared with the shrubs at Schooner, which were protected from winds by the canyon, and the amounts of fallout deposited around them in the bottom of the canyon. The increased reduction in the dose to the back of Cabriolet shrubs may thus be both a measure of self-shielding in the conventional sense and a sheltering effect from wind patterns about the shrubs analogous on a microscale to conditions in the canyon at Schooner. Another possibility, for which we do not have data, is that under some conditions windswept surfaces may intercept less fallout; this is probably a function of surface roughness.

Dose Reduction by Polyethylene Cover Sheets

The relatively large reduction in dose resulting from use of 6-mil polyethylene sheets was not entirely anticipated. The gamma-ray-dose reduction of 15.5% and the reduction of nearly 70% in beta dose must certainly be significant in terms of the subject of this symposium. Beta burns have been noted as an outstanding characteristic of fallout-radiation effects for both domestic animals^{7,8} and men.⁹

Survival of Food Crops and Livestock

The conditions resulting from close-in fallout under which this study was made, like those for Cabriolet and Palanquin, appear to be as nearly like conditions of nuclear warfare as can be simulated. In these experiments there

were depositions of large amounts of particulate materials containing nuclear debris which arrived near time zero. In the last few years, fallout-decay dose rates have only been simulated in the laboratory, and it has been shown that certain crop plants are more sensitive than was previously predicted under these conditions.¹⁰ Since these experiments utilized only gamma radiation, there may be other effects associated with beta radiation and the higher beta energies of radioactive debris from near time zero not yet simulated in the laboratory.

A few simple conclusions can be drawn. First, the relatively large doses to crops in the field, or to exposed seeds, from beta radiation must be considered. Perhaps some practical, simple dosimetry for beta radiation is needed. The large variations in the ratios of beta- to gamma-radiation doses and the possible errors in calculating doses from late postevent dose rates make beta-dose estimates difficult. These difficulties may decrease with increasing distances from GZ, but this is a problem for meteorologists, and for the present whether or not this occurs appears to be unknown.

From the importance of beta radiation as an agent of damage, it follows that prevention of direct contamination by fallout particles is vital. Even a shield with as little mass as that afforded by 6 mils of polyethylene sheeting may be of critical importance.

For livestock or crops that cannot be sheltered against direct contamination, the lee sides of any large object may provide some protection. It has frequently been observed that the presence of large shrubs and small trees decreased the airborne fallout damage to smaller shrubs downwind. In this matter geographical features themselves also appear to provide limited protection.

Finally, it is obvious that more information from direct fallout effects will be very useful.

ACKNOWLEDGMENTS

This work was done under Contract No. AT(29-1)-1183 between Environmental Sciences Branch, Division of Biology and Medicine, U. S. Atomic Energy Commission, and EG&G, Inc., Santa Barbara Division. Part of the work was also done under Contract No. AT(40-1)-2412 between the USAEC and Emory University.

REFERENCES

1. L. R. Anspaugh et al., Bio-Medical Division Preliminary Report for Project Schooner, USAEC Report UCRL-50718, University of California, Livermore, July 22, 1969.
2. W. A. Rhoads, R. B. Platt, and R. A. Harvey, Radiosensitivity of Certain Perennial Shrub Species Based on a Study of the Nuclear Excavation Experiment Palanquin, with Other Observations of Effects on the Vegetation, USAEC Report CEX-68.4, EG&G, Inc., May 1969.

3. W. A. Rhoads, R. B. Platt, R. A. Harvey, and E. M. Romney, Ecological and Environmental Effects from Local Fallout from Cabriole. I. Radiation Doses and Short-Term Effects on the Vegetation from Close-In Fallout, USAEC Report PNE-956, EG&G, Inc., June 25, 1969. (Beta dosimetry methods are provided by A. D. Kantz and K. C. Humpherys in an appendix.)
4. Lora M. Shields and Philip V. Wells, Effects of Nuclear Testing on Desert Vegetation, *Science*, **135**: 38-40 (1962).
5. A. D. Kantz, Measurement of Beta Dose to Vegetation from Close-In Fallout, this volume.
6. Carl F. Miller, The Contamination Behavior of Fallout-Like Particles Ejected by Volcano Irazu, Report AD-634901, Stanford Research Institute, April 1966.
7. D. G. Brown and others, Late Effects in Cattle Exposed to Radioactive Fallout, *Amer. J. Vet. Res.*, **27**: 1509-1514 (1966).
8. M. C. Bell and C. V. Cole, Vulnerability of Food Crop and Livestock Production to Fallout Radiation, USAEC Report TID-24459, UT-AEC Agricultural Research Laboratory, Sept. 7, 1967.
9. Samuel Glasstone (Ed.), The Effects of Nuclear Weapons, rev. ed., USAEC Report ACCESS-127, p. 601, Defense Atomic Support Agency, 1962.
10. A. H. Sparrow and Leanne Puglielli, Effects of Simulated Radioactive Fallout Decay on Growth and Yield of Cabbage, Maize, Peas, and Radish, *Radiat. Bot.*, **9**: 77-92 (1969).

SURVIVAL AND YIELD OF CROP PLANTS FOLLOWING BETA IRRADIATION

ROBERT K. SCHULZ

Department of Soils and Plant Nutrition, University of California, Berkeley, California

ABSTRACT

Field experiments were carried out to investigate the effect of beta radiation on the growth of wheat, lettuce, and corn. The beta-radiation exposure was accomplished by fusing ^{90}Y onto 88- to 175- μ silica sand, and applying the sand to the crops with a remote-control applicator. Treatment levels on the wheat and lettuce crops ranged up to 59.4 mCi of ^{90}Y per square foot. In the corn experiment the highest level was 71.3 mCi of ^{90}Y per square foot. Wheat grain production was severely reduced when 6.6 mCi/sq ft of ^{90}Y was applied. This corresponds to approximately 2700 rads at the surface of the plant near the apical meristem. Lettuce yields were reduced significantly only at the highest treatment level, 59.4 mCi/sq ft, which corresponds to 9300 rads at the plant surface near the apical meristem. Some abnormalities could be seen on the lettuce at the 6.6 mCi/sq ft treatment level. Corn yield was not reduced and plant appearance was not changed in any of the treatments. The apical meristem of the corn plant was protected by about 1 cm of tissue, and it hence received very little ionizing radiation.

In the event of nuclear war, standing crops would be exposed to ionizing radiation from fallout containing both beta and gamma radiation in generally similar amounts. The study reported here is an investigation of the possible effects from the beta component.

Extensive literature exists on the effects of gamma radiation on plants in contrast to the very limited information available concerning the effects of beta exposure to plants.

It is widely accepted that the relative biological effectiveness (RBE) of beta to gamma doses is essentially unity¹ in the moderate and high beta energies found in fallout resulting from a nuclear detonation. This means that, when given ergs of energy are transferred to a fixed amount of tissue, deleterious effects will be the same whether the ionizing radiation is beta or gamma. In spite of this consideration, few predictions can be made of beta damage from gamma data, because of geometrical effects. The gamma exposure tends to be uniform

throughout all the smaller plants, whereas beta exposure varies enormously because of absorption by plant tissue. Since the maximum range of the most energetic beta particles found in fallout is only a few millimeters in tissue, the more sensitive areas of the plant may receive little exposure to beta radiation. On the other hand, because of the fact that the beta energy is transferred to the tissue over a short path, the beta component could be very important where the sensitive plant parts are not protected. Rhoads et al.² have shown that the beta component in fallout at the Nevada Test Site has been primarily responsible for the death of some desert vegetation.

Based on these considerations, it was felt that the beta investigation should be carried out under field conditions with normal plant densities and as normal an agricultural management as possible. In this work the effects of beta radiation on wheat, lettuce, and corn were investigated.

MATERIALS AND METHODS

The Kearney Horticultural Field Station of the University of California was used for carrying out the field research. Yttrium-90 was selected as the beta-emitting isotope because of its availability, its suitable half-life of 64.2 hr, and its average energy of 0.92 MeV.

Although the half-life of 64.2 hr is somewhat longer than that of early fallout, ⁹⁰Y was felt to be the best choice among available single isotopes to represent a fallout situation. It was decided to apply ⁹⁰Y to the crops as simulated fallout, i.e., fixed on 88- to 175- μ silica sand. Before the field experimentation could be initiated, three problems had to be solved. (1) Extreme radiochemical purity of the ⁹⁰Y fallout simulant had to be assured. The ⁹⁰Y was to be chemically separated from a ⁹⁰Sr-⁹⁰Y mixture, and, owing to radiation-safety requirements, the residual ⁹⁰Sr radioactivity could not exceed 10^{-5} of the ⁹⁰Y activity. (2) A method of applying the fallout simulant evenly had to be developed. Since a number of curies would be involved in each experiment, radiation-safety considerations again were important. (3) A beta-radiation-dosimetry system had to be developed for measuring the beta doses delivered to the plants.

Radiochemical Purity of the ⁹⁰Y Fallout Simulant

The 88- to 175- μ sand contaminated with various levels of ⁹⁰Y was prepared by W. B. Lane of the Stanford Research Institute (SRI) at the Camp Parks Hot Cell facility. Basically Lane's method³ consists of separation of ⁹⁰Y from a ⁹⁰Sr-⁹⁰Y mixture by precipitation of Sr(NO₃)₂ in concentrated nitric acid. Carrier-free ⁹⁰Y remaining in solution is then fused on the silica sand at 925°C. For radiation-safety considerations two modifications were made in this procedure. (1) The sand was eluted in water to remove all fine particles less than 88 μ and returned to SRI for use in simulant preparation. (2) After the ⁹⁰Y was

separated from the ^{90}Sr - ^{90}Y mixture by SRI, it was purified in our laboratory to remove remaining traces of ^{90}Sr contamination. The method used was a modification of the Brookhaven ^{90}Y generator.⁴ Essentially this purification depended on complexing the cation yttrium to an anion, yttrium citrate. Strontium carrier was added to the solution, and the solution was then passed over an ammonium-saturated cation-exchange column. This method results in an overall radiochemical separation of ^{90}Sr from ^{90}Y of greater than 10^7 . The purified ^{90}Y was then returned to SRI for fixing on the sand.

Fallout-Simulant Applicator

An apparatus that would apply the fine, highly radioactive sand evenly to the crops with safety to the operator had to be constructed. This required glove-box loading of the machine and remote operation of the applicator. The sand was to be applied at the rate of 10 g/sq ft on 4- by 4-ft plots.

The essential part of the applicator consists of a 6-in.-wide hopper of triangular cross section. A four-vaned, notched stirrer was mounted at the bottom, and the sand was discharged through No. 60 drill holes (Fig. 1). Sand delivery was started and stopped by a hopper valve operated by a rotary



Fig. 1 Sand hopper. Sand is agitated by notched stirrer and falls through No. 60 drill holes at bottom of hopper. Delivery of sand is started and stopped by solenoid-operated valve on bottom of hopper.

solenoid. The rate of sand dispensing as a function of time is given in Fig. 2. It was found that, when 500 g of sand was placed in the hopper, the first 340 g was delivered at a uniform rate; then delivery became nonuniform. The delivery rate decreased, then increased briefly, and finally decreased again; this was not an experimental anomaly but a real, duplicable result.

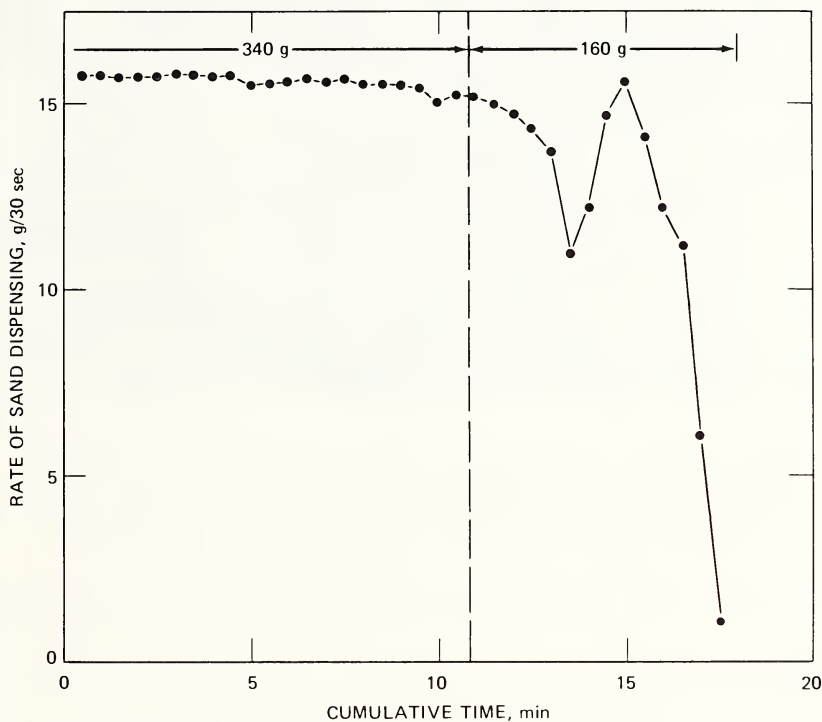

Fig. 2 Sand delivery from hopper as a function of time. Hopper contained 500 g 88- to 175- μ silica sand at start of run.

The hopper or dispersing head is mounted on an apparatus that moves the head across the plot while laying down a 6-in. swath of sand (Fig. 3). Before each end of the pass, the hopper valve closes while the head is reversing direction. The whole apparatus moves perpendicular to the line of head travel so that, when the head has completed one cycle (i.e., across the plot and back), it has moved perpendicularly 6 in. This results in the uniform sand pattern depicted in Fig. 4. At the start and finish, there is a 6-in. by 4-ft isosceles triangle of single sand coverage. The rest of the area receives double coverage by the dispersing head. Speeds were calculated to give 10 g/sq ft. Actual rate of sand dispensing was checked by placing 30 1-qt ice-cream cartons within the 4- by 4-ft area. The amount of sand collected in each carton is given in Table 1. Standard deviation of a single value of 30 measurements was 0.09 g with a mean

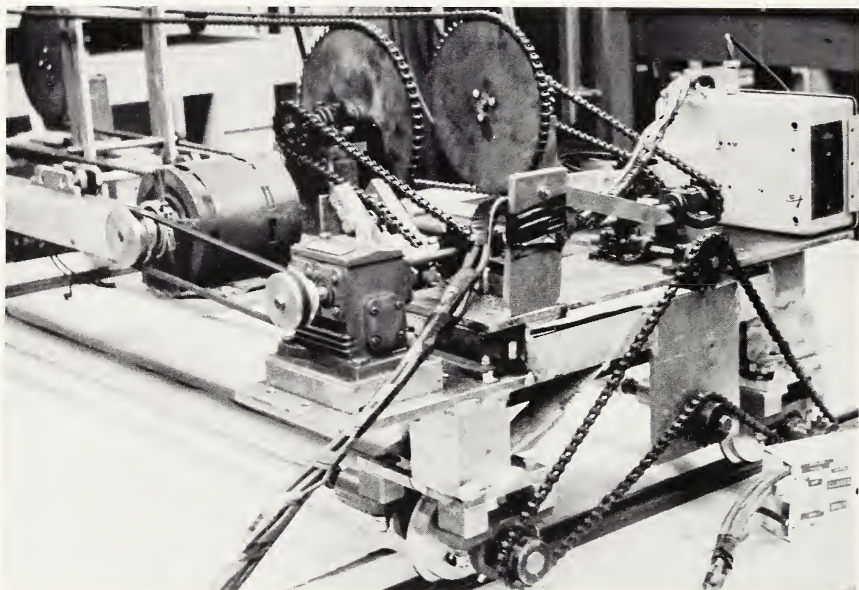

Fig. 3 Complete sand applicator. Hopper moves back and forth across the plot laying down a 6-in. swath of sand while the whole apparatus moves perpendicular to the line of head travel.

of 0.99 g per carton. This gives a calculated deposition of 10.3 g of sand per square foot.

Beta-Radiation Dosimetry

Development of a beta-radiation dosimetry system designed for use in the field was carried out with the cooperation of EG&G, Inc., Goleta, Calif. Micro-beta-radiation thermoluminescent dosimeters (TLD) consisting of $\text{CaF}_2\text{-Mn}$ chips sealed in thin, black polyethylene film were developed. The dosimeters consist of approximately 0.25-mm cubes weighing approximately 40 μ . Initially the procedure consisted in reading the exposed dosimeters with an EG&G reader; each dosimeter was standardized after each reading by exposure to a standard cobalt source and again read out. This procedure was standardized against a primary standard electron source. This was done in two ways at the EG&G laboratory. Dosimeters were exposed to an electron beam from a Febetron, and the dose was calculated from the known energy and distance from the source. The dose was also determined by calorimetry. Finally, the dose was determined by the EG&G cobalt standardization readout procedure and compared with other results. The experiments were designed by Asher Kantz of EG&G.

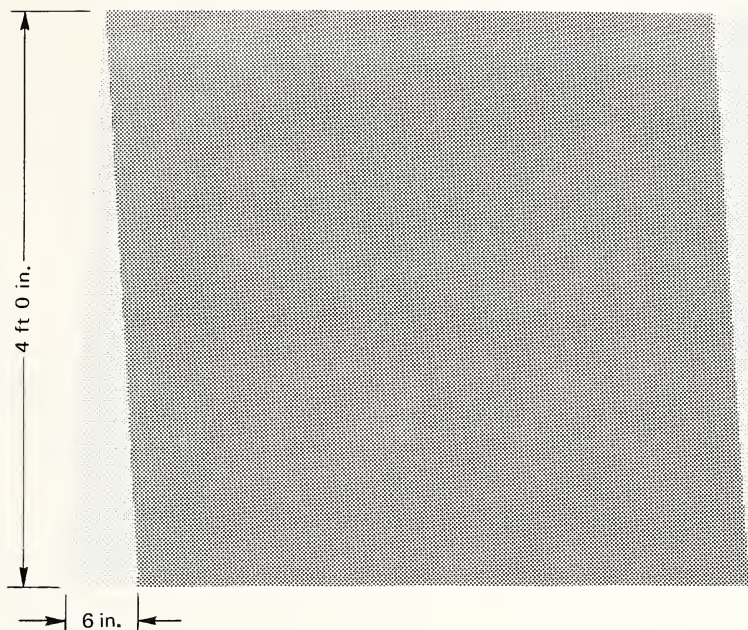

Fig. 4 Diagram of sand coverage. Sand is applied to plot with 6-in.-wide traveling head so that at the start and finish there is a 6-in. by 4-ft isosceles triangle of single sand coverage. The rest of the area receives double coverage.

Table 1
SAND COLLECTED BY 1-qt ICE-CREAM CARTONS

Carton No.	Weight of sand, g	Carton No.	Weight of sand, g	Carton No.	Weight of sand, g
1	1.0235	11	0.8026	21	0.8536
2	0.9308	12	1.0395	22	0.9358
3	1.2168	13	0.9187	23	0.9818
4	1.1159	14	1.0170	24	0.9625
5	1.0164	15	0.8650	25	0.9805
6	0.8861	16	1.0118	26	1.0298
7	1.0787	17	1.1521	27	1.0645
8	1.0758	18	0.9020	28	1.0345
9	1.0037	19	0.9312	29	0.9180
10	1.0563	20	0.9547	30	1.0422

Average weight per carton = 0.9933 ± 0.0911

Table 2
COMPARISON OF ABSORBED DOSE IN MICRO TLD CHIPS

Distance from Febetron exit window to target, cm	Predicted dose, krads	Thermocouple dose, krads	TLD dose, krads
8.0	36.8	35.0	36.0
3.0	313	270	306

The electron source used was a Febetron 706, which is a field-emission diode device. The electrodes are charged to 600 keV, and the electrons are delivered in a 5-nsec pulse. The penetration of the electron beam has been measured and has the same characteristics as a 550-keV monoenergetic electron beam. The ratio of the dose to energy fluence from the beam was also measured, and again it was found that the energy was slightly above 500 keV.

For satisfactory absorption characteristics, we found it necessary to maintain the target in a vacuum. At a given separation of the face of the electron tube and the target, the reproducibility of the absorbed dose from shot to shot was $\pm 12\%$. For a series of experiments, a CaF_2 -Mn chip was placed in a known position in the electron beam. A chromel-constantan thermocouple (0.002-in. wire) was attached to the chip with a minimum of pliabond cement. The temperature rise experienced by the CaF_2 was recorded and the absorbed energy calculated. The thermocouple was then detached, and the amount of thermoluminescence in the chip was measured in a standard EG&G TLD reader. The energy absorption by the TLD measurement was calibrated against the response in a ^{60}Co -source range. Agreement of the electron energy absorption with the ^{60}Co energy deposition verifies that the energy absorption from the two sources is equal. To compare these measurements against the energy absorption predicted by the placement at a given position, we took a series of 3 to 5 shots for each measurement. The summary of the results of two such measurements is given in Table 2.

The conditions of the electron source used for this experiment make it mandatory to have a CaF_2 chip that is thin compared with 500-keV electrons. The range of such electrons in CaF_2 is approximately 0.22 g/cm^2 or 0.028 in. Chips with a thickness from 0.007 to 0.015 in. were used for the thermocouple measurements.

When the chips were broken into small volumes, the reproducibility was poor. Sawing the chips into 0.25-mm cubes gave a reproducibility within $\pm 3\%$ for a given chip.

To save on expense and time, we developed our own standardization and readout procedure. For this purpose we purchased an EG&G model TL-003A TLD reader and outfitted it for reading the micro dosimeter chips. A 4π exposure chamber constructed for standardization of each dosimeter using ^{90}Y

of known concentration is illustrated in Fig. 5. Basically, it consists of two lucite cylinders, each having a 1-in. wall thickness and a 1-in. lucite bottom. The top of each cylinder is covered with a 0.00025-in.-thick (approximately 0.64 mg/cm^2) Mylar membrane. The dosimeters are placed on the membrane so that the distance to any wall exceeds the maximum range of the ^{90}Y radiation in water. The other cylinder is then inverted and secured to form a 4π -geometry exposure chamber. Standardized ^{90}Y is then carefully introduced into both halves of the

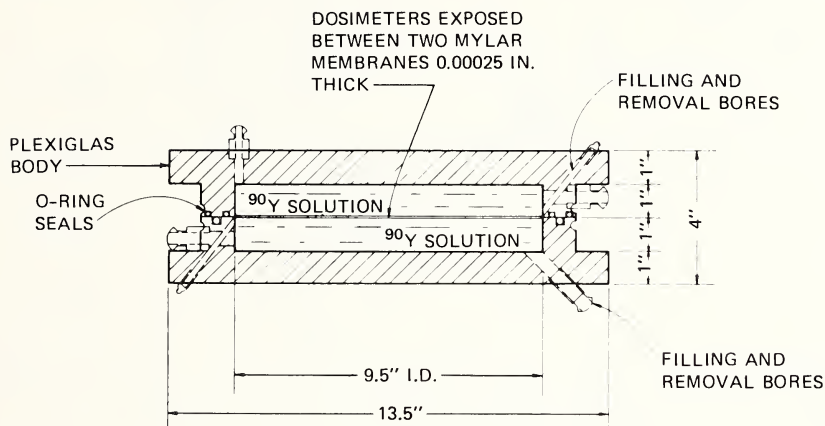

Fig. 5 The 4π chamber for exposing TLD dosimeters to a known amount of beta radiation. ^{90}Y solution concentrations ranged from 0.5 to 500 $\mu\text{Ci/ml}$.

chamber to completely fill the apparatus; there must be no entrapped air. After the dosimeters have been exposed for a given time, the ^{90}Y solution is transferred back into the ^{90}Y storage bottle. Both halves of the chamber are rinsed with dilute HCl and water and then dried by flowing warm, dry air through the system. This is done to prevent dilution of the ^{90}Y solution as it is successively used in repeated filling of the chamber for various exposures of the dosimeters. The apparatus is illustrated in Fig. 6. Appropriate traps, air dryers, and filters prevent contamination of the atmosphere by the vacuum and air lines used in filling and drying the apparatus.

The ^{90}Y solutions were supplied by the SRI Camp Parks Hot Cell facility. The concentrations were determined in our laboratory both by comparison with a ^{90}Sr - ^{90}Y standard source from which the ^{90}Sr radiation was absorbed out and by comparison with a standard ^{32}P source. The agreement was to within 5%. A 1-ml sample of ^{90}Y was taken from the storage bottle before and after each use of the ^{90}Y in the 4π chamber to monitor for any losses of ^{90}Y from the solution by deposition on surfaces.

In the first experiment with the apparatus, dosimeters were exposed for various times and at various ^{90}Y solution concentrations. The dose was computed with the aid of the equation given in Quimby and Feitelberg,⁵

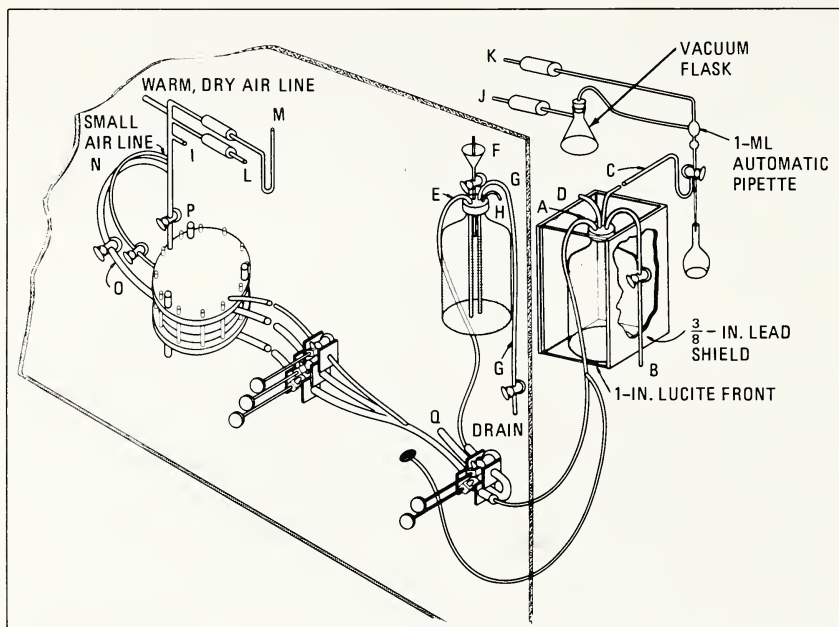

Fig. 6 Apparatus for filling, rinsing, and drying 4π exposure chamber.

A	Line to lower three-way stopcock	K	Line to atmosphere
B	^{90}Y introduction lines	L	Line to atmosphere
C	Line to sampling pipette	M	Line to manometer
D	Vacuum line for filling ^{90}Y supply bottle	N	Line for removal of entrapped air (bottom chamber)
E	Line to acid-wash bottle	O	Large line for drying air (bottom chamber)
F	Funnel for introduction of acid and water	P	Large line for drying air (top chamber)
G	Drain line	Q	Drying-air exhaust line leading to filters
H	Vacuum line		
I	4π chamber vacuum line		
J	Samples vacuum		

where $D = 73.8 c \bar{E}_\beta T$ (c is the concentration, \bar{E}_β is the average beta energy, and T is the time).

The results of this experiment are plotted in Fig. 7; the calculated dose is plotted against the dose reported by EG&G. The points shown are averages of data from 10 to 15 different dosimeters. The 45° line is shown for comparison. These results are somewhat erratic, but the agreement was generally encouraging.

In the next experiment a large number of dosimeters were again dosed at varying rates in the 4π chamber and subsequently read out on the TLD reader. The results are shown in Fig. 8, in which the calculated dose is plotted against

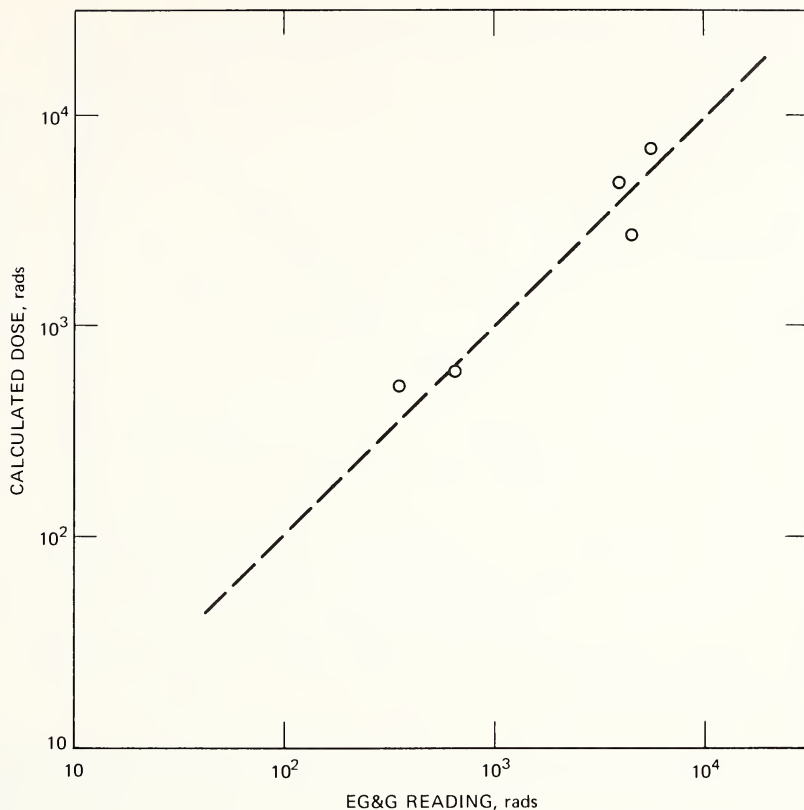

Fig. 7 Calculated dose in the 4π exposure chamber plotted against dose reported by EG&G.

the instrument reading. Again, each point is the average of a number of dosimeters receiving the same dose. The results again are somewhat erratic, but the relation appears to be linear. In future work we plan to calibrate each dosimeter individually to eliminate the variability caused by dosimeter size.

To test the effectiveness of the polyethylene packaging, we dosed approximately 50 dosimeters equally in the 4π chamber and divided them into two lots. One lot was then exposed to the weather for a period of about 2 months, and the other lot was kept as a control. Both lots were then read in the EG&G reader. If we use Fig. 8 as a calibration curve, the control chips read at 4730 rads and the exposed chips read at 4480 rads. For the purposes of our subsequent field experiments, in which the chips are exposed to weather, this difference is not important.

Absorption of ^{90}Y radiation by polyethylene was studied by placing polyethylene sheets of varying thickness between the chips and the Mylar

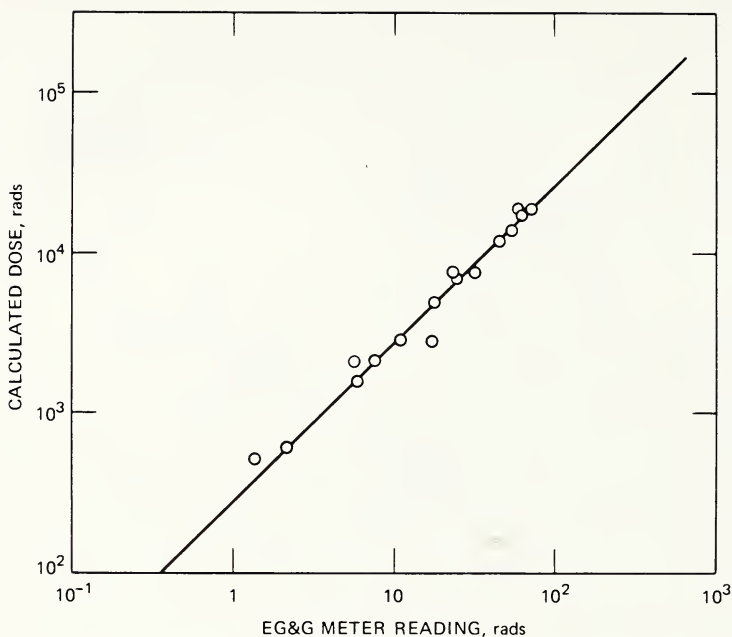

Fig. 8 Calculated dose in the 4π exposure chamber plotted against the reading of the EG&G instrument.

membranes. Again using Fig. 8 as a calibration curve, we found the dose in rads. In these experiments the chips were packaged in 1.5-mil, black polyethylene, except for one case in which bare chips were exposed. The thickest polyethylene absorber was 0.5 in. The observed dose divided by the calculated dose from the 4π exposure chamber was then plotted against the absorber thickness, as shown in Fig. 9. Note that evidently there is a maximum in the curve. The point plotted on the ordinate is for bare chips, however, and it is not known whether the lower value is due to exposure to light or to a dose-depth effect. The value on the ordinate is, of course, 100% at 1.5 mils since this was also the packaging used in establishing the calibration curve.

EXPERIMENTAL DATA

Preliminary Experiment

Before designing the field experiments, we carried out a preliminary experiment in a controlled-environment chamber. This experiment utilized a wide range of ^{90}Y concentrations to determine the general levels at which beta-radiation damage to wheat and lettuce plants occurs. The radioactive sand was applied to foliage of 6-week-old plants growing in pots by entraining the

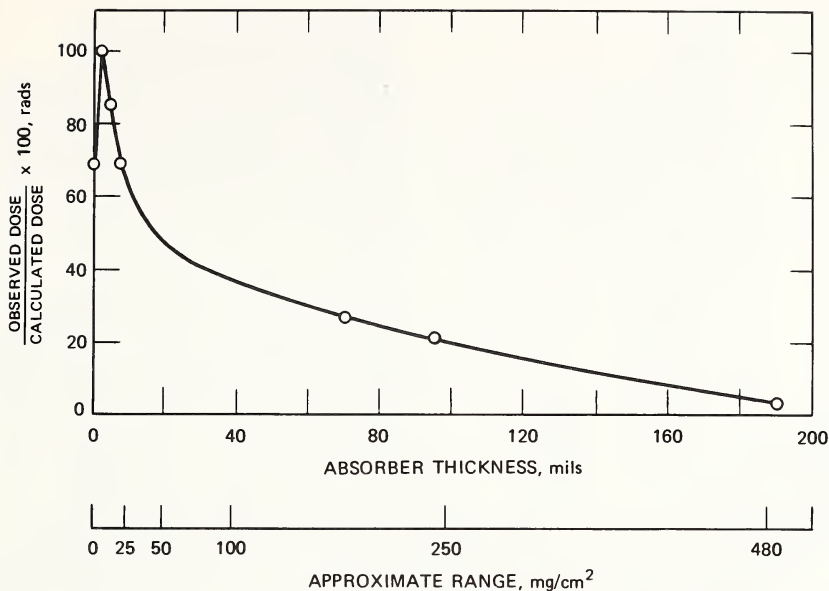

Fig. 9 Absorption of ^{90}Y beta radiation by polyethylene sheets of varying thickness.

sand in an air stream, employing a modification of Shelby's device,⁶ and then dropping the sand down a tube onto the plant foliage and soil surface. The treatment levels were such that ^{90}Y was added to the pots at the rate of 1.5, 5.3, 17.5, 87, and 205 mCi/sq ft. The wheat was quite sensitive; grain production had ceased at the 17.5 mCi/sq ft level. Variability was rather large in this preliminary experiment, but the results were felt to be adequate to serve as a guide for planning the field experiments. The lettuce was somewhat more tolerant to ^{90}Y exposure; the yield began to decrease at the 17.5 mCi/sq ft level. From this level to the highest level used, 205 mCi/sq ft, there was a gradual decrease in yield. Visual aberrations to plant growth occurred at a much lower level of beta exposure. At the lowest level of treatment, 1.5 mCi/sq ft, some visual changes were noted, and at 5.3 mCi/sq ft obvious anatomical aberrations were present.

Since visual changes in growth of the lettuce occurred at much lower levels than yield reduction, it was felt that microscopic examination of the apical meristems and other plant parts might prove interesting. Figure 10 is a photomicrograph of a normal apical meristem at the apex of the fleshy crown stem. Figure 11 gives detail of this meristem. Note that a single layer of cells forms the tunica, which overlies a corpus several cells thick. In normal tissues such as this, these cells are not vacuolated. Figure 12 shows a shoot meristem of a plant treated with ^{90}Y sand at 17.5 mCi/sq ft. Here there is no visible effect,



Fig. 11 Normal apical meristem. (Magnification, 140 X.)

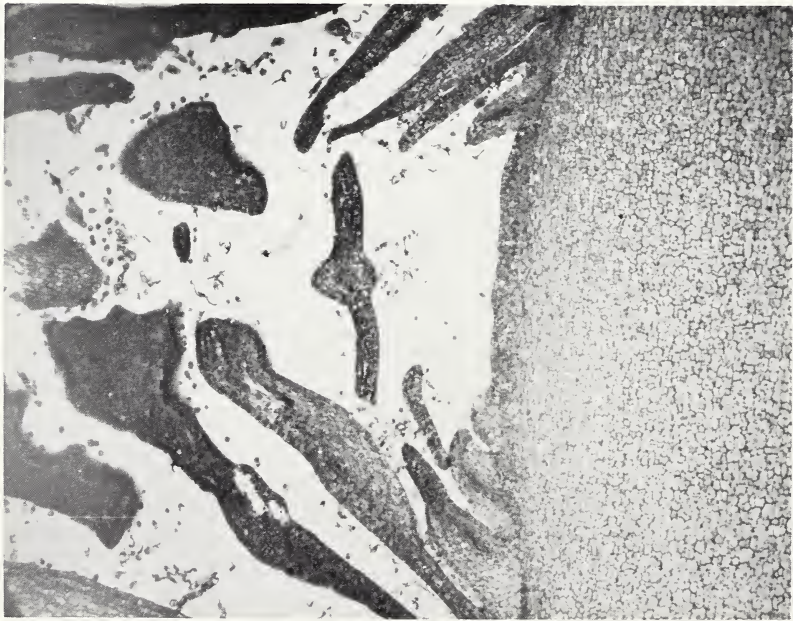

Fig. 10 Normal apical meristem. (Magnification, 70 X.)

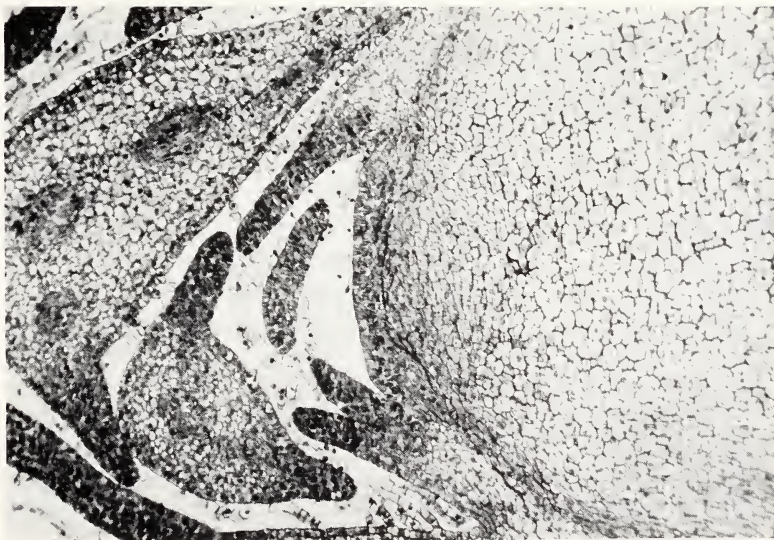

Fig. 12 Meristem of plant treated at 17.5 mCi/sq ft. (Magnification, 119 X.) Meristem appears normal although plant is visually damaged.

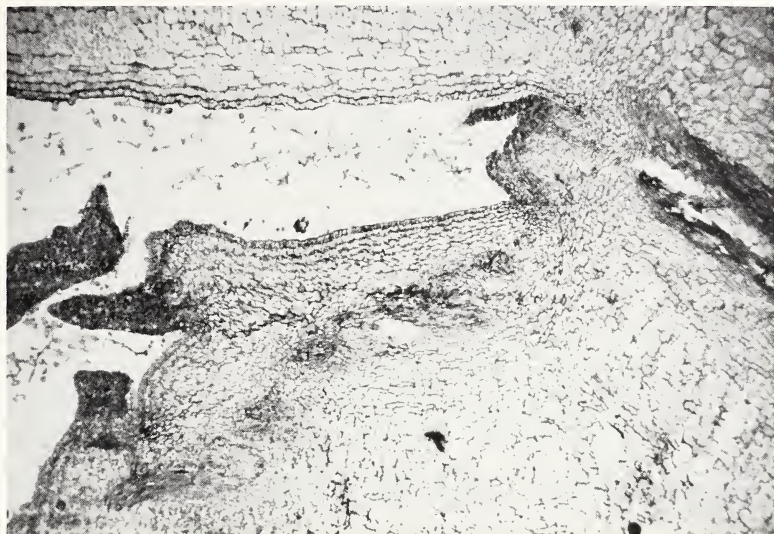

Fig. 13 Two abnormal shoot apices formed in axials of young leaves of plant treated at 87 mCi/sq ft. (Magnification, 60 X.)

even though the whole plant evidenced marked gross anatomical aberrations and yield reductions were becoming evident. Figure 13 shows one of a set of twin apices found on a plant treated with ^{90}Y sand at 87 mCi/sq ft. This photomicrograph shows two abnormal shoot apices formed in the axials of young leaves. The terminal meristem is at the upper left-hand corner. Figure 14 is a detail of Fig. 13 which shows the upper of the two shoot apices formed in the leaf axials. Note that this secondary meristem is itself damaged by radiation. The cells of the tunica and corpus are vacuolated. Figure 15 shows the shoot apex of a plant treated with ^{90}Y sand at 205 mCi/sq ft. Here all cells are vacuolated and no cell division is occurring. Figure 16 shows cross section of young normal leaf near midrib. Note the prevalence of nonvacuolated cells in the epidermis and mesophyll. The bundle sheath surrounding the vascular bundle extends to form the rib of the leaf. The vascular bundle consists of, from top to bottom, xylem, phloem, and lactiferous ducts and fibers. Figure 17 shows a young leaf treated with ^{90}Y sand at 205 mCi/sq ft. Here the midrib is swollen because of vacuolation and swelling of mesophyll. Distinction between the bundle sheath and mesophyll is lost.

Field Experiments

The results of the preliminary experiment were used in the design of the field experiments carried out at the University of California Kearney Horticultural Field Station located near Fresno. The soil at the Kearney Station is a Hanford sandy loam formed on recent alluvium. The exchange capacity is about 5 milliequivalents per 100 g and is Ca^{2+} dominated. The salt content is very low, and the area is generally one of high agricultural productivity.

The field plots are described in Fig. 18. Each plot is 8 by 20 ft. The entire area is surrounded by a radiation-safe wire fence with a 6-ft reed fence attached to the wire for wind control. In the first experiment lettuce (Cos) or wheat (Pitic 62) was planted in each 8-ft by 20-ft plot, but only a 4- by 4-ft area in the center of each plot was contaminated. The beta exposure was by means of ^{90}Y fused on 88- to 175- μ quartz sand at 925°C. This material was prepared by W. B. Lane at SRI.

The wheat and lettuce were planted on Mar. 27, 1969, and the ^{90}Y sand was applied on May 16, 1969. The lettuce was harvested on June 10, 1969, 75 days after planting. The wheat was harvested on July 10, 1969, giving a growing period of 105 days. On the day of ^{90}Y application, the lettuce had an average width of 18.7 cm, an average height of 14.5 cm, and an average weight of 56.3 g. At this time the wheat had an average height of 33 cm, and the apical meristems were approximately 1 cm above ground level.

The sand was applied at rates of 0.26, 0.78, 2.25, 6.64, 19.8, and 59.4 mCi of ^{90}Y per square foot by remote control with the applicator previously described. Before the sand was applied, 212 micro dosimeters were placed at various locations in the plots, and their positions were recorded. The plots are shown at time of treatment in Fig. 19.



Fig. 15 Shoot apex at treatment level of 205 mCi/sq ft. All cells are vacuolated, and no cell division is occurring. (Magnification, 119 X.)



Fig. 14 Detail of Fig. 13 at magnification of 119 X. Note that secondary meristem is damaged by radiation.

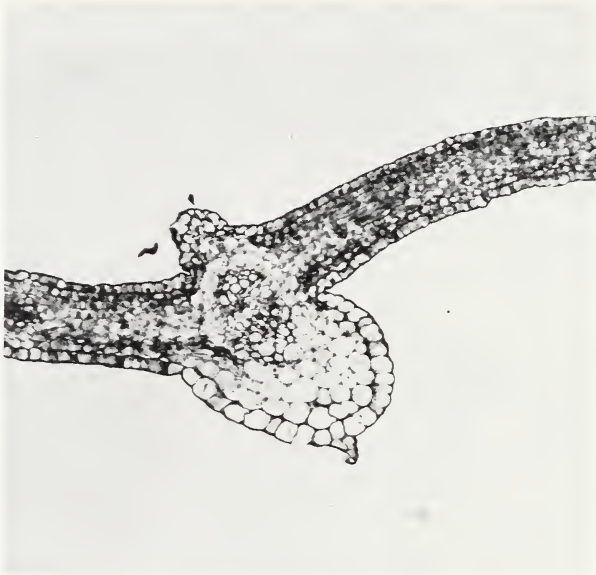

Fig. 16 Cross section of normal young leaf. Note non-vacuolated cells in epidermis and mesophyll. (Magnification, 150 X.)

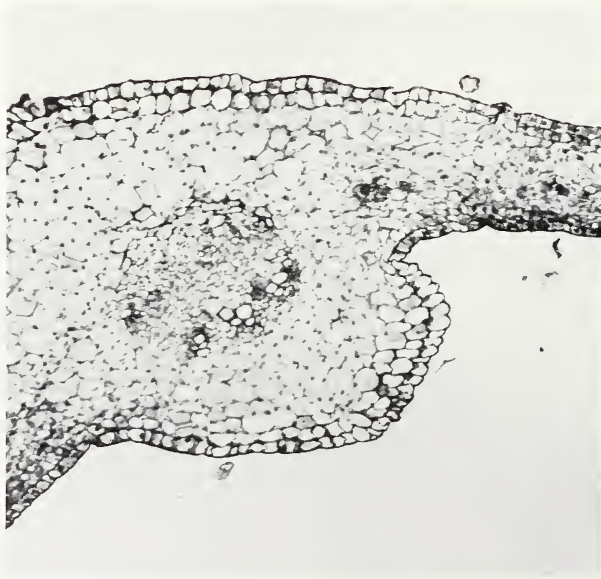

Fig. 17 Young leaf treated with ^{90}Y at 205 mCi/sq ft. Midrib is swollen, and distinction between bundle sheath and mesophyll is lost. (Magnification, 150 X.)

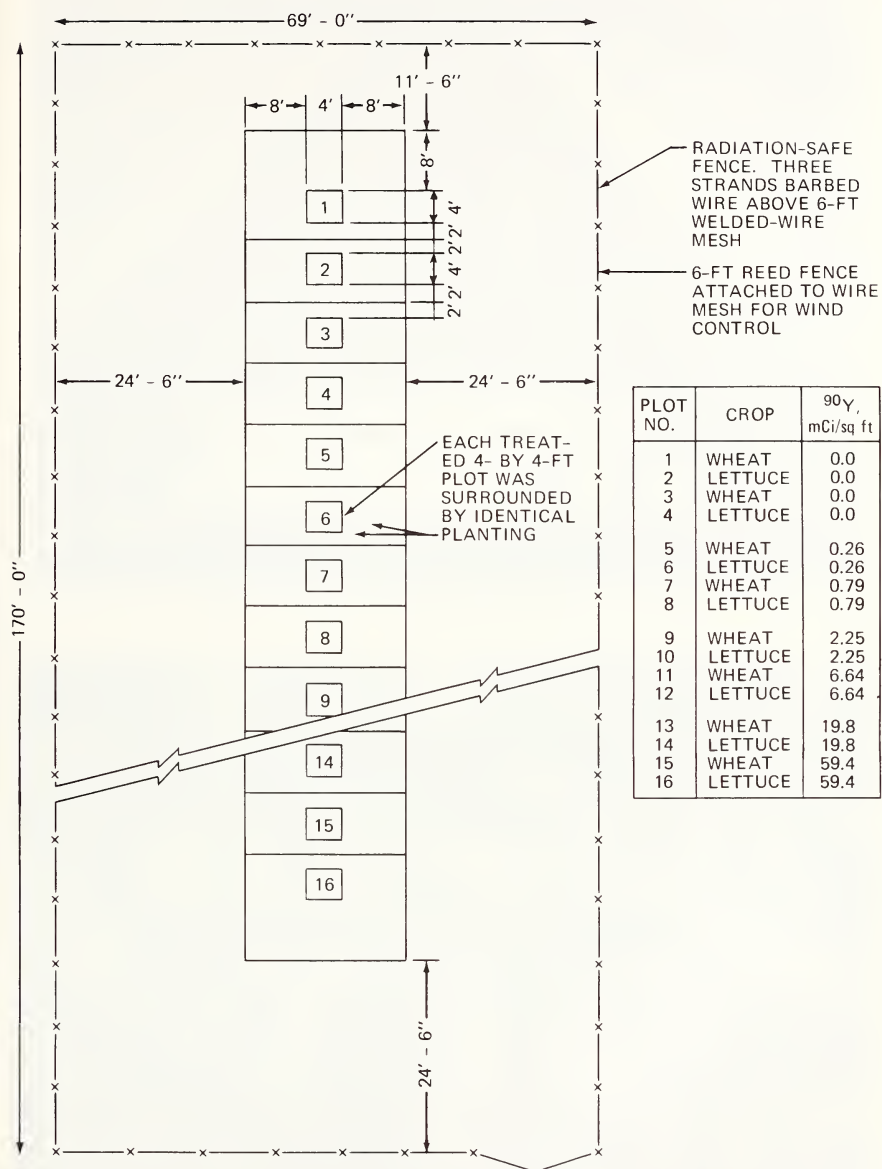

Fig. 18 Arrangement of field plots for ^{90}Y beta-radiation experiment at Kearney Horticultural Field Station near Fresno, California. The ^{90}Y was fused on 88- to 175- μ quartz sand at 925°C.



Fig. 19 Appearance of field plots at time of application of ^{90}Y .



Fig. 20 Accumulation of radioactive sand on corn leaves. Sensitive parts of corn plants are well protected from beta radiation, and no damage occurred at the highest level of treatment (71.3 mCi/sq ft).

Table 3
DOSE RECORDED BY MICRO DOSIMETERS AT VARIOUS LOCATIONS IN THE PLOTS

Plot No.	⁹⁰ Y applied, mCi/sq ft	Dose to wheat meristem, rads	Dose to lettuce meristem, rads	Wheat plots, rads		Lettuce plots, rads	
				At 6 in.	At 12 in.	At 6 in.	At 12 in.
				5, 6	0.26	105	55.3
7, 8	0.78	353	164	270	114	205	116
9, 10	2.25	958	357	467	337	353	239
11, 12	6.64	2727	1026	1151	935	1129	844
13, 14	19.8	6460	3226	3990	1881	2645	2052
15, 16	59.4	9548	9262	9576	5586	Lost	5016

Table 4
WHEAT YIELD DATA

⁹⁰ Y treatment, mCi/sq ft	Plot No.	Aerial growth			Tillers without heads			Tillers with heads		
		Weight of air-dried plants, g/sq ft	Number of plants per sq ft	Number per sq ft	Height, cm	Number per sq ft	Height, cm	Grain per sq ft		
								Number	Weight, g	
Control	3	61	20	40.2	15	41	50.3	286	9.14	
0.26	5	97	20	52	19	65	52.0	432	14.44	
0.78	7	73	19	11	13	50	54.2	480	18.26	
2.25	9	89	26	43	17	63	51.1	424	13.53	
6.64	11	52	17	30	15	40	46.2	135	3.80	
19.8	13	79	20	49	15	49	49.9	61	1.41	
59.4	15	47	16	100	17	12	36.2	40	0.47	

Table 5
LETTUCE YIELD DATA

⁹⁰ Y treatment, mCi/sq ft	Plot No.	Yield	
		Fresh weight, g	Dry weight, %
Control	4	305.3	7.0
0.26	6	296.3	6.5
0.78	8	301.7	6.4
2.25	10	250.0	7.2
6.64	12	272.4	6.4
19.8	14	258.1	8.2
59.4	16	148.6	11.1

Dosimeters were placed on the plants as close as possible to the apical meristems and at 6 and 12 in. above the soil surface. The doses accrued during the experiment are given in Table 3. The yield data are given in Tables 4 and 5.

After the wheat and lettuce were harvested, a corn experiment was carried out in the same area. The corn crop was contaminated with the radioactive sand 34 days after planting. At this time the apical meristem was about 23 cm above ground, and the plants were about 61 cm high and had a stem-base diameter of 2 cm. The rate of sand application was 10 g/sq ft, as in the previous experiment, and the specific activity was varied to give 6.74, 12.9, 34.6, and 71.3 mCi/sq ft. Although the sand is spread evenly on the area, it accumulates on the plants unevenly as shown in Fig. 20. No yield reduction (5% level) was observed even in the highest level of treatment.

DISCUSSION

It is seen from the wheat data that at 6.64 mCi/sq ft (corresponding to 2700 rads at the surface of the plant near the shoot meristem) grain production is severely reduced. Reduction in aerial growth, however, occurred only at the highest treatment level. In plot 13, there was no obvious damage to the plants other than the reduction in the grain. At the highest level, in plot 15, chlorotic leaves and stem shortening were observed. Photographs of tillers and grain from plot 13 are shown in Figs. 21 to 24.

The lettuce plants are much less sensitive to the ⁹⁰Y treatment. Yield was reduced significantly only at the highest level of treatment. In this case the plants were stunted in appearance, and brown necrotic areas developed on the leaf edges. The center of many of the plants had no new growth; where bolting occurred, the leaves were distorted. Figure 25 shows a damaged lettuce plant from the highest contamination level. In Fig. 26 a plant from the same plot has resumed growth and shows multiple growing points.



Fig. 21 Wheat head from control plot.

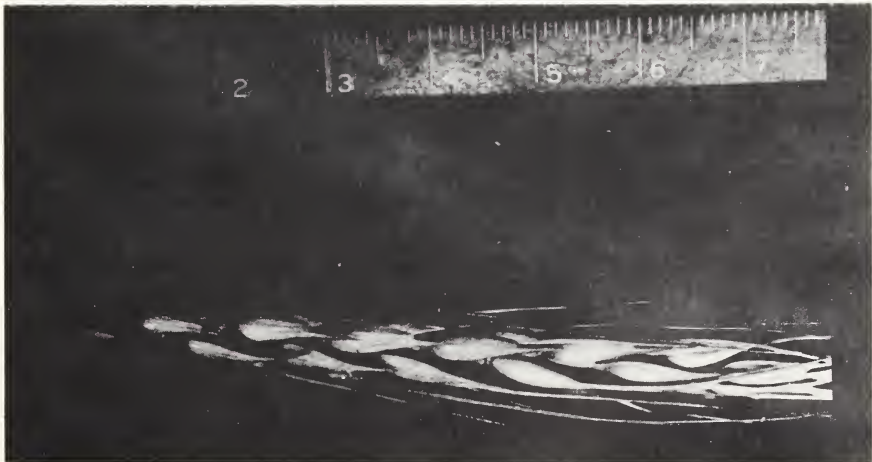

Fig. 22 Wheat head from plant exposed to ^{90}Y at 19.8 mCi/sq ft. Color is much darker brown than control.



Fig. 23 Wheat grain from control plot.

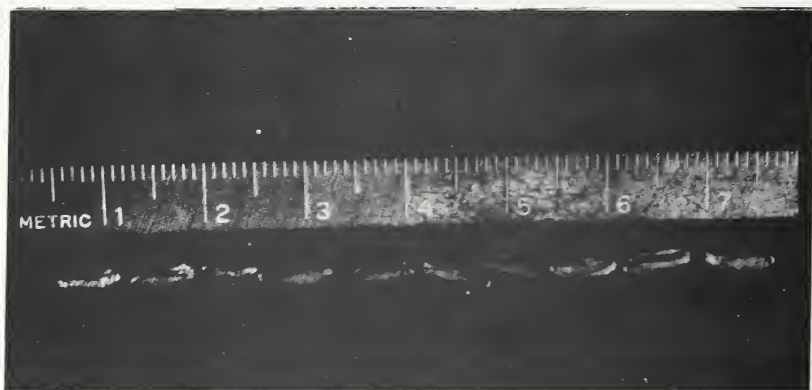

Fig. 24 Wheat grain from plot treated with ^{90}Y at 19.8 mCi/sq ft.

The relation between the amount of radioactivity applied (in microcuries per square foot) and the dose (in rads) to the meristem for each crop is interesting (Fig. 27). In each case there is a linear relation between the applied radioactivity and the dose.

Dosimeters tied near the apical meristem of the corn plants recorded a surface dose of about 5000 rads at the highest level of treatment, but the apical meristem was obviously well shielded by the large sheath protecting it. The protection afforded the shoot meristem can readily be seen by examination of the data presented in Fig. 9. This result suggests that consideration of the stage of development of the corn plant may be particularly important in assessing beta-radiation effects. In addition, the leaves exposed to the beta radiation were



Fig. 25 Lettuce plant from plot treated with ^{90}Y at 59.4 mCi/sq ft. Damage was generalized with no apparent recovery, no new growth in center of plant.



Fig. 26 Lettuce plant from same plot as that in Fig. 25. Note that in this plant some recovery has taken place in the center of the plant. The new growth consists of multiple growing points as contrasted to the single growing point normally found in lettuce plants.

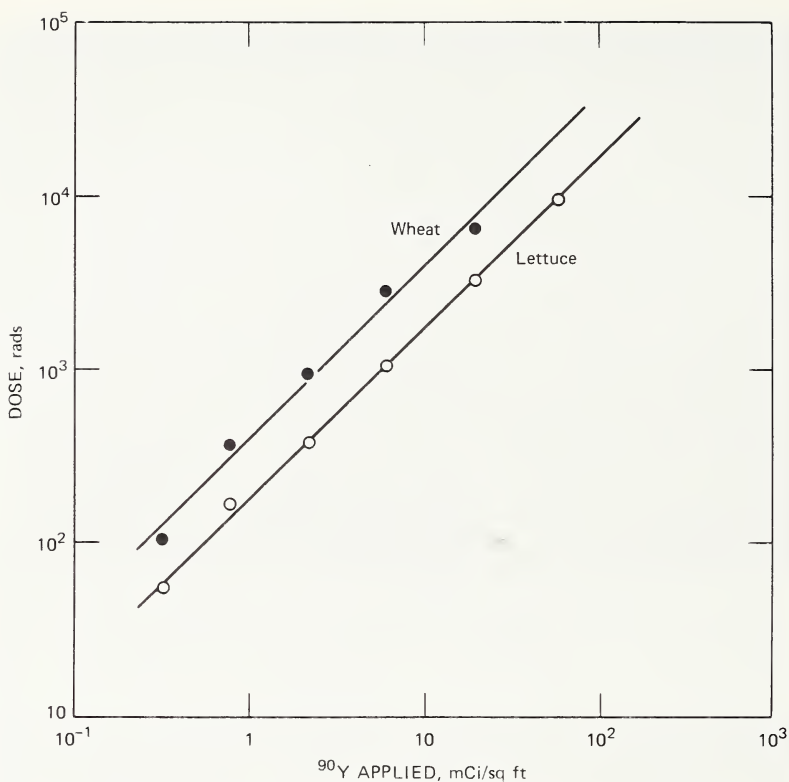

Fig. 27 Relation between ^{90}Y applied to plots and dose measured at apical meristem of plants. Data for both wheat and lettuce are for an average of four plants each.

quite resistant to damage; no visual aberrations were discernible. During the period when cell division is taking place to produce the leaf, the meristematic tissue is well protected by the older, nonsensitive leaves.

No plants were killed in any of these experiments, even at the highest levels of treatments. This is in agreement with the data of Schulz and Baldar⁷ on wheat and lettuce exposed to beta radiation by immersion in ^{90}Y solutions. The apparent resistance of the plants to death by beta-radiation exposure is probably due to the uneven plant exposure. Some plant parts are relatively protected, and the plant does not receive a whole-plant exposure such as it would with gamma radiation. From the data accumulated so far, the beta-exposure survival level for agricultural crops appears to be far above the level necessary to cause severe yield reduction; therefore yield rather than survival is the important criterion in assessing beta damage to food crops.

ACKNOWLEDGMENTS

This study was supported by the U. S. Atomic Energy Commission and the Office of Civil Defense, Department of the Army.

REFERENCES

1. E. H. Quimby and S. Feitelberg, *Radioactive Isotopes in Medicine and Biology*, Vol. 1, *Basic Physics and Instrumentation*, p. 142, Lea & Febiger, Philadelphia, 1963.
2. W. A. Rhoads, R. B. Platt, R. A. Harvey, and E. M. Romney, Ecological and Environmental Effects from Local Fallout from Cabriole. I. Radiation Doses and Short-Term Effects on the Vegetation from Close-In Fallout, USAEC Report PNE-956, EG&G, Inc., June 25, 1969.
3. W. B. Lane, Fallout Simulant Development, SRI Project No. MU-7236, Stanford Research Institute, 1969. (OCD Work Unit 3211C.)
4. R. F. Doering, W. D. Tucker, and L. G. Stang, Jr., A Simple Device for Milking High Parity Yttrium-90 from Strontium-90, *J. Nucl. Med.*, 4: 54-59 (1963).
5. E. H. Quimby and S. Feitelberg, *Radioactive Isotopes in Medicine and Biology*, Vol. 1, *Basic Physics and Instrumentation*, pp. 112-113, Lea and Febiger, Philadelphia, 1963.
6. W. E. Shelby, J. L. Mackin, and R. K. Fuller, Artificial Surface Dirts for Detergency Studies with Painted Surfaces, *Ind. Eng. Chem.*, 46: 2572 (1954).
7. R. K. Schulz and N. Baldar, Beta Radiation Effects on Plants, paper presented at the Symposium on Vulnerability of Food Crops and Livestock Production to Fallout Radiation, Colorado State University, Fort Collins, Colo., June 1969.

FIELD STUDIES OF FALLOUT RETENTION BY PLANTS

JOHN P. WITHERSPOON

Ecological Sciences Division, Oak Ridge National Laboratory, Oak Ridge, Tennessee

ABSTRACT

Several field studies on the retention by plants of local fallout particles (particles exceeding 44μ in diameter) are summarized.

Although initial fractions of fallout intercepted varied as a function of plant-foliage characteristics and particle size, average initial retention values are similar for studies done with a wide variety of plants in different geographical regions.

Rapid losses of particles from foliage and other plant parts due to weathering occurred generally during the first week following initial particle deposition. Losses from tree species during this period were several times greater than losses from crop plants. In a period of 1 to 2 weeks following deposition all plants lost 90% or more of the fallout particles initially intercepted.

After about 3 weeks the loss of particles was relatively constant and proceeded at a slow rate (average weathering half-life of 21.3 ± 3.9 days) regardless of subsequent rain and wind conditions.

The formulation of realistic predictions of the biological effects of fallout on vegetation requires information on both the radiosensitivity of plants exposed to radiation in fallout geometries and the capacity of vegetation to intercept and retain fallout particles. Since about 64% of the total radiation dose from fallout is delivered during the first week after detonation of a nuclear device, initial interception, sites of deposition, and early losses of particles are critical events in estimating dose to contaminated plants.

This paper reviews some field studies on contamination of plants by local fallout and discusses the significance of these studies in the evaluation of short-term biological hazards involved in using nuclear devices for peaceful or military purposes.

Studies on retention of local fallout particles by plants have been made under both varying geographic and varying particle-source conditions. However,

in many of these studies, the early losses of fallout from plants due to weathering have not been determined. This is particularly true of local fallout particles exceeding 44μ in diameter. Deposits of particles exceeding 44μ usually contain an appreciable fraction of fallout radioactivity, and they can represent a major source of radiation dose to plant tissues, although they may be briefly retained. Small particles constitute the bulk of radioactive debris deposited as worldwide fallout, but they lose much of their radioactivity via physical decay before deposition and are of greater biological significance as a major source of entry of radioactivity into food chains.

INITIAL RETENTION OF FALLOUT BY PLANTS

The initial retention of fallout by a given plant species depends on a number of factors. Such plant characteristics as surface area (mainly foliage), density, and surface characteristics of leaves are important variables. Meteorological conditions during deposition, particularly wind velocity and relative humidity, also influence initial retention. Finally, the size and amount of falling particles influence the degree to which plants are contaminated. Several field studies have been conducted in which the initial contamination of plants has been determined and related to one or more of these factors.

The initial retention of fallout by plants can be expressed in two ways. One is the foliage contamination factor (a_l) used by Miller:¹

$$a_l = Ci^0 / m_i \quad \text{sq ft/g} \quad (1)$$

where Ci^0 is the quantity in microcuries of radionuclide initially intercepted per gram of dry weight of foliage and m_i is the quantity in microcuries of radionuclide deposited per square foot of soil surface area. Another expression of initial retention is the fraction (F) of fallout which is intercepted by plants or foliage:

$$F = a_l w_l \quad (2)$$

where w_l is the biomass of foliage, or of the plant, in grams per square foot of soil surface area.

Values of a_l for plants sampled after nuclear tests have been smaller than values reported in other field tests where nonnuclear sources of fallout were applied. Miller,¹ reviewing a_l values for plants sampled following weapons tests, reported a range of 2×10^{-5} to 0.013 sq ft/g. Other estimates have been made by Martin.² Values from three weapons tests (Priscilla, Buffalo Round 2, and Sedan) ranged from 0.002 to 0.012, with an average of 0.004 sq ft/g. Most of the plant samples taken after nuclear detonations were collected several days after initial deposition of fallout or after some losses due to weathering had

occurred. Also, results from test-site fallout fields were usually obtained in areas of light to moderate fallout.

Plant contamination values derived from several field studies with local fallout and, where samples were taken before appreciable weathering, are fairly consistent. The a_1 values for a variety of different plant species were taken by Miller¹ in Costa Rica following deposition of fallout from the Irazu volcano. A median value of 0.05 sq ft/g was reported for dry exposure conditions and particles having a median diameter between 50 and 100 μ . In studies at Oak Ridge National Laboratory, Witherspoon and Taylor³ reported an average a_1 value of 0.057 ± 0.024 sq ft/g for five species of crop plants treated with 88- to 175- μ diameter particles. In similar studies⁴ values of 0.035 and 0.005 sq ft/g were reported for oak and pine tree foliage, respectively. Values for relatively small-leaved plants such as pine⁴ (0.005), lespedeza³ (0.010), and fescue grass⁵ (0.011) tend to be smaller than those for large-leaved plants.

Therefore an a_1 value of 0.05 sq ft/g seems reasonable for calculating initial beta-exposure doses to plants in areas of local, dry fallout deposition (or where particles exceed 50 μ in diameter). A value of about 0.01 may represent a good estimate for most narrow-leaved plants. Under damp conditions (relative humidity greater than 90%), or where foliage surfaces are wet, a_1 values have been reported to increase by an average of two to four times those obtained under dry conditions.^{1,6}

Reported values of F, initial fraction of fallout intercepted by plants relative to amount deposited per open soil surface area, are summarized in Table 1.

Table 1
INITIAL RETENTION OF SIMULATED FALLOUT DEPOSITED IN AN ACUTE
MODE UNDER DRY CONDITIONS

Plant	Retention, %			Foliage area Soil surface area sq ft/sq ft	Plant density, g/sq ft of soil
	44- to 88- μ particles	88- to 175- μ particles	175- to 350- μ particles		
White pine ^{4*}		24.2			44.6
Red oak ⁴		34.9			9.9
Squash ³	100.0	88.5		1.72	6.4
Soybean ³	100.0	100.0		3.11	11.4
Lepedeza ³	7.5	1.9		0.51	1.9
Peanut ³	9.8	5.8		0.91	4.4
Sorghum ³	48.9	10.8		1.25	5.4
Fescue ⁵	45.4	19.6			17.4
Pasture grass ⁶		7.4	5.5		9.2
Alfalfa ⁶		23.0	5.0		19.5
Corn ⁶		44.0			

* Reference number.

Initial retention can be seen to vary both with plant-foliage types and with particle size. Where retention values for different particle sizes can be compared, there is an average of two to three times less initial retention when particle size range is increased by a factor of 2. This is particularly evident in plants having small leaves and small foliage surface area relative to soil surface area. Mass loading of particles used in the studies summarized in Table 1 varied from about 0.5 to 13.6 g of particles per square foot of open soil surface. In one series of studies⁶ where mass loading was varied, initial retention was found to be independent of mass loading over this range.

Sites of retention other than foliage can be important in determining biological effects of fallout radiation on plant species. Table 2 gives the average

Table 2
FRACTION OF TOTAL INITIAL RETENTION IN PLANT PARTS*

Plant	Plant part	Fraction of	
		44- to 88- μ particles	88- to 175- μ particles
Squash	Stem	0.051	0.037
	Flowers	0.007	0.032
	Foliage	0.942	0.931
Sorghum	Stalk	0.259	0.086
	Foliage	0.741	0.914
White pine	Bud clusters		0.160
	Foliage		0.840

*Fallout applied under dry conditions at a mass loading of from 4.5 to 6.6 g per square foot of open soil surface.

fraction of total initial retention associated with various plant parts. For these particular species the foliage intercepted most of the fallout, but small fractions were intercepted by radiosensitive structures such as flowers and buds. In the white pine, a relatively radiosensitive plant species, a large fraction of fallout is trapped in clusters of buds on the ends of branches. Since these buds contain meristematic tissues, which are the most radiosensitive parts of the vegetating plant, these trapping sites represent critical regions. Particles trapped in these structures also are retained longer than particles intercepted by pine foliage.⁴ Flowers also may intercept small fractions of fallout. In squash plants, Table 2, initial interception by flowers of particles 44 to 88 μ in diameter was less than that of 88- to 175- μ particles applied at the same mass loading. The larger particles may have had a tendency to bounce or roll off foliage into open flowers, whereas smaller particles were more efficiently intercepted by foliage and stem surfaces. Smaller particles, in the 44- to 88- μ range, were intercepted by vertical structures, such as sorghum stalks, with much greater efficiency than

larger particles. Grasslike plants such as sorghum, corn, and fescue have effective particle-trapping sites in the leaf axils, angles between the leaves and stems.^{3,5,6} Unless particles contain enough radioactivity to produce damage to tissue from contact doses, however, these trapping sites may not be biologically important since they are somewhat removed from more radiosensitive meristematic regions.

LOSS OF FALLOUT FROM PLANTS DUE TO WEATHERING

The major meteorological factors that influence retention of fallout by plants are wind speed and rainfall. Estimation of early losses of fallout particles from plants, particularly for the first week following initial deposition, is critical in determining dose to contaminated plants. Results from studies on retention indicate that concentrations of radionuclides on fallout-contaminated plants can be expected to decrease at rates significantly higher than would be predicted on the basis of physical, radioactive decay. Beta-radiation-exposure geometries may be expected to change rapidly from a contact to a bath mode of exposure.

Loss of fallout from foliage during the first day following deposition is rapid under dry conditions with relatively gentle wind speeds. Table 3 illustrates

Table 3
PROMPT LOSSES OF 88- TO 175- μ PARTICLES FROM FOLIAGE

Plant	Time after deposition, hr	Initial interception remaining, %	Wind, mph	Rain, in.
Corn ^{6*}	24	94	0 to 20	
Alfalfa ⁶	24	82	0 to 20	
Squash ³	36	52	0 to 5	
Soybean ³	36	49	0 to 5	
Sorghum ³	36	90	0 to 5	
Peanut ³	36	44	0 to 5	
Lespedeza ³	36	74	0 to 5	
Fescue ⁵	18	34	0 to 1.5	
White pine ⁴	1	90	0 to 12	
White pine ⁴	24	6.3	0 to 15	0.9
Red oak ⁴	1	9.5	0 to 12	
Red oak ⁴	24	0.4	0 to 15	0.9

*Reference number.

prompt losses for 10 plant species studied under similar conditions of deposition mode and weather. In most cases these losses amount to 50% or more of the amounts initially intercepted. Studies with smaller particles (44 to 88 μ) have indicated that first-day losses are as great as with 88- to 175- μ particles.³ Rapid particle loss from other plant structures also may be expected. Table 4 gives

Table 4
LOSSES OF 88- TO 175- μ PARTICLES FROM SQUASH AND
SORGHUM DUE TO WIND ACTION

Time, days	Wind, mph	Retention, %*				
		Squash			Sorghum	
		Foliage	Flowers	Stem	Foliage	Stalk
0.5	0 to 5	86.2	37.5	93.0	96.8	53.4
1.5	0 to 5	52.4	14.8	90.0	90.0	33.8
7	0 to 7	36.0	10.0	44.1	47.0	2.6

*Percent of initial interception value.

retention values for stem and flowers of squash and for sorghum stalks. Rate of loss of particles from squash foliage was greater than that from the stem over a period of 1 week after initial deposition. It is probable that stems, which are prostrate and under the large leaves, intercepted some of the particles dislodged from foliage by gentle winds during this period. The more rapid loss rate from flowers was due, in this case, to wilting and loss of petals during this period—a phenological event. Rapid losses from structures such as the vertical stalks of sorghum were expected.

Some generalizations concerning the probable retention of fallout by trees vs. agricultural plants may be made. Table 5 gives average foliage-retention values for five crop species³ that vary in growth habit and leaf-surface characteristics and for two tree species that represent very common tree-foliage types. Initial

Table 5
AVERAGE RETENTION* OF 88- TO 175- μ PARTICLES BY PLANTS UP TO
5 WEEKS AFTER DEPOSITION

Time after application, days	Average retention of five crop species, ³ %	Accumulated rainfall, in.	Average retention, %		Accumulated rainfall, in.
			Average retention, %		
			White pine ⁴	Red oak ⁴	
0.04		0	91.0 \pm 10.0	9.50 \pm 0.81	0
1	74.0 \pm 8.3	0	6.3 \pm 0.8	0.39 \pm 0.06	0.90
1.5	61.8 \pm 8.7	0	4.5 \pm 0.4	0.25 \pm 0.04	0.90
7	33.0 \pm 4.6	0.25	2.5 \pm 0.2	0.02 \pm 0.003	1.30
14	9.4 \pm 4.7	1.28	2.1 \pm 0.2	0.015 \pm 0.001	1.43
21	2.7 \pm 1.2	2.67	1.9 \pm 0.3	0.012 \pm 0.001	1.47
28	2.6 \pm 1.5	2.67	1.6 \pm 0.2	0.010 \pm 0.002	2.88
35	2.6 \pm 1.6	2.67	1.2 \pm 0.1	0.010 \pm 0.002	3.46

*Average percent of initial interception \pm 1 standard error.

particle losses, up to 1 week, were much greater for the trees. The data for trees reflect, however, the effects of one rain which fell 12 hr after initial deposition. The losses from crop plants for the first 6 days were due to wind action only. Nevertheless, with comparable rainfall for the duration of these studies, up to 5 weeks after deposition, losses from trees were greater. Smooth-leaved trees, such as the red oak, retained only a small fraction of the initial deposition after 1 week. All these plants lost the major portion (90%) of the fallout in 1 to 2 weeks, a period in which the major portion of fallout-radiation dose is delivered. Not only did the trees lose particles faster than the crop species tested but also, from the standpoint of dose, this loss is more important for trees. Particle loss can also be interpreted as a change in beta-exposure geometry from a contact to a bath mode, and the most radiosensitive structures (meristems and flowers) are located at greater distances from the ground in trees than in crop plants. Therefore bath doses from fallout on the ground would be less serious, impart less dose, to trees than to crop plants because of their relatively greater height.

Retention of particles beyond 2 weeks was relatively stable for trees and crop plants regardless of amount of wind and rainfall. By this time most of the fallout has probably become trapped in sites upon which subsequent weathering has little effect. Retention characteristics after this time may be important from the standpoint of chronic low-level dose or transfer into food chains.

Data on fallout retention of plants or plant parts plotted vs. time typically take the form of an exponential curve. In the calculation of half-lives, however, it is difficult to express these data in terms of a single weathering or effective half-life.⁴ Rapid particle losses during the first day or week and subsequent loss-rate changes after early weathering imply that retention data should be compartmentalized into appropriate time components for half-life analyses. Table 6 gives weathering half-lives for 88- to 175- μ particles on seven species of plants. These half-lives are given for three time components: initial deposition to 1.5 days, when very rapid loss rates occur; 1.5 to 14 days; and 14 to 33 days, when loss rates tend to stabilize at a very slow rate. Averaging these weathering half-lives gives some indication of general particle retention for a wide variety of plants. Such averages may be useful in dose calculations for periods up to several weeks following deposition.

Environmental half-lives (e.g., half-life rates of loss due to causes other than radioactive decay) of radionuclides on fallout-contaminated plants were reported by Martin⁷ for plants in the Sedan fallout field. Bartlett et al.⁸ reported these values for plants sprayed with fission-product solutions. In the Sedan fallout field from 5 to 30 days after detonation, the environmental half-lives for fallout ⁸⁹Sr and ¹³¹I were 28 and 13 to 17 days, respectively.⁷ Fission products sprayed on grass exposed to wind and rain up to 60 days had an average environmental half-life of about 14 days.⁸

The average weathering half-life for the 14- to 33-day time component in Table 6 is 21.3 ± 3.9 days. Thus it appears that weathering or environmental half-life values for different kinds of vegetation growing in different geographical

Table 6
WEATHERING HALF-LIVES OF 88- TO 175- μ PARTICLES ON FOLIAGE
FOR THREE TIME COMPONENTS

Plant	Half-life for 0 to 1.5 days, days,	Rain, in.	Half-life for 1.5 to 14 days, days,	Rain, in.	Half-life for 14 to 33 days, days,	Rain, in.
White pine ^{4*}	0.69	0.9	13.09	1.43	26.14	1.97
Red oak ⁴	0.64	0.9	6.11	1.43	42.58	1.97
Squash ³	1.62	0	7.36	1.28	15.06	1.39
Soybean ³	1.47	0	7.19	1.28	15.97	1.39
Sorghum ³	4.10	0	7.43	1.28	19.43	1.39
Peanut ³	1.33	0	15.71	1.28	16.07	1.39
Lespedeza ³	2.88	0	7.55	1.28	14.07	1.39
Average \pm 1 standard error	1.82 \pm 0.48		9.20 \pm 1.33		21.33 \pm 3.96	

*Reference number.

regions may be similar after the rapid initial losses during the first week or so have occurred. The average values for different species (1.82 \pm 0.48 days for the 0- to 1.5-day component and 9.20 \pm 1.33 days for the 1.5- to 14-day component) and the ranges given in Table 6 suggest that weathering half-lives may differ only by a factor of slightly over 1 to about 6.5 between species during the periods of rapid initial particle loss.

The similarities in results from field studies in which particle size approximates that of local fallout are striking. Both initial contamination factors, such as the a_1 value, and weathering half-lives for time components may be in close enough agreement so that the use of averages, such as those presented here, would give reasonable estimates of dose from fallout when used in appropriate models.

ACKNOWLEDGMENT

This research was sponsored by the U. S. Atomic Energy Commission under contract with Union Carbide Corporation and the Office of Civil Defense, Department of Defense.

REFERENCES

1. C. F. Miller and H. Lee, Operation Ceniza-Arena. Part One, SRI Project MU-4890, Stanford Research Institute, 1966.

2. W. E. Martin, Early Food-Chain Kinetics of Radionuclides Following Close-In Fallout from a Single Nuclear Detonation, in *Radioactive Fallout from Nuclear Weapons Tests*, Germantown, Md., Nov. 3-6, 1964, A. W. Klement (Editor), AEC Symposium Series, No. 5 (CONF-765), 1965.
3. J. P. Witherspoon and F. G. Taylor, Interception and Retention of a Simulated Fallout by Agricultural Plants, *Health Phys.*, **19**: 493-499 (1970).
4. J. P. Witherspoon and F. G. Taylor, Retention of a Fallout Simulant Containing ^{137}Cs by Pine and Oak Trees, *Health Phys.*, **17**: 825-829 (1969).
5. R. C. Dahlman, in Progress Report in Postattack Ecology. Interim Report, USAEC Report ORNL-TM-2983, Oak Ridge National Laboratory, December 1970.
6. J. E. Johnson and A. I. Lovaas, Deposition and Retention of Simulated Near-In Fallout by Food Crops and Livestock, Technical Progress Report 3223C, Colorado State University, 1969.
7. W. E. Martin, Losses of ^{90}Sr , ^{89}Sr and ^{131}I from Fallout-Contaminated Plants, *Health Phys.*, **4**: 275-284 (1964).
8. B. O. Bartlett, L. F. Middleton, G. M. Milbourn, and H. M. Squire, The Removal of Fission Products from Grass by Rain, in *Surveys of Radioactivity in Human Diet and Experimental Studies*, British Report ARCRL-5, pp. 52-54, 1961.

RETENTION OF NEAR-IN FALLOUT BY CROPS

A. I. LOVAAS and J. E. JOHNSON
Colorado State University, Fort Collins, Colorado

ABSTRACT

Near-in fallout simulant, 88- to 175- and 175- to 350- μ sand labeled with ^{177}Lu , was dispersed over field crops. Initial retention and weathering half-time were measured for alfalfa, corn, barley, bromegrass, sudan grass, and sugar-beet tops.

Papers in this session have considered the biological effects of gamma and beta radiation on plants, especially crop plants, with the intent of evaluating parameters for models that postulate biological consequences of fallout radiation.¹ Constantin, Siemer, and Killion* showed the stage specific effects on uniformly administered gamma radiation. Bottino and Sparrow* extended the study of biological effects to a gamma field decreasing in intensity over time. Rhoads et al.* described combined gamma and beta effects of actual test-site fallout. Both Shulz* and Witherspoon* dealt with the biological effects of applied deposits of beta-emitting fallout simulant. This report is on retention experiments employing a material similar to that used by Witherspoon. Our interest is in bulk contamination of potential animal feed as well as in the finer features of particle retention on plants.² A body of related data on volcano dust has been detailed by Miller's group³ at Sanford Research Institute (SRI).

BACKGROUND

We have studied the capacity of plant canopies to retain sand-size falloutlike particles. A simulant was chosen to be similar to material swept into the air by a nuclear blast over a silicate-soil region. Of all the particles produced by or swept

*This volume.

into a nuclear cloud, we are concerned with those in the size range of $100\ \mu$, i.e., near-in or local fallout as distinguished from the worldwide variety.⁴ Particles much smaller than 20 to $40\ \mu$ are preferentially carried beyond near-in deposits, whereas particles of several hundred microns, i.e., approaching 1 mm, are rapidly depleted.⁵ We used batches of sand of 88 to 175 and 175 to $350\ \mu$ for these exposures. The sand is from the reserve of fallout-simulant materials maintained and supplied by SRI.

Two processes may be considered to constitute the mechanism of external retention of particles by plants. Small particles adhere to rough or sticky surfaces, and cupping structures are effective means of holding the larger particles that would otherwise bounce or roll off. Both the initial retention governed by these two processes and the lasting retentive properties of plant surfaces and structures are modified by weathering, observably by the wetting of rain, buffeting by wind, and tearing by hail.

OBJECTIVES AND EXPERIMENTS

At Colorado State University our field experiments seek to show initial and persistent retention characteristics of species, some weather effects on initial retention, and the step changes they cause in retention functions. We exposed standing field crops to the simulant of near-in fallout. Radioactivity was used only as a particle tracer and not to produce biological effect.

The study attempted to simulate portions of near-in fallout derived from silicate soil in respect to particulate material, particle size, particle fall conditions, and amount of deposited material (mass load). Since we wished to follow foliar deposits of particles and not foliar absorption of radionuclides, an essentially insoluble form of radiotracer was used. The nuclide employed was ^{177}Lu . This labeled material was prepared by W. B. Lane of SRI.⁶

In the winter of the first crop year of our study, some nonradioactive releases were carried out in an enclosed chamber (Fig. 1). This permitted the determination of retention under conditions of still air and controlled surface moisture (Fig. 2). Plants for the chamber releases were from greenhouse stock. Chamber results showed that overall retention was commonly doubled by maximum spray wetting. Readily wetted and fairly flat bean-leaf surfaces that accumulate droplets retained up to 15 times as much sand when spray wetted as before treatment. Since, when leaves dry, much of the sand pattern approximates that of the evaporated droplets, it is clear that the excess retention by wet surfaces depends largely on the area and depth of surface moisture that a leaf can retain and support.

Under the stable conditions of the enclosed chamber, it was also possible to use a grain crop at several growth stages to observe retention efficiency of the developing stand. The increasing stem-to-leaf ratio with growth was manifested as lowered specific retention for barley.

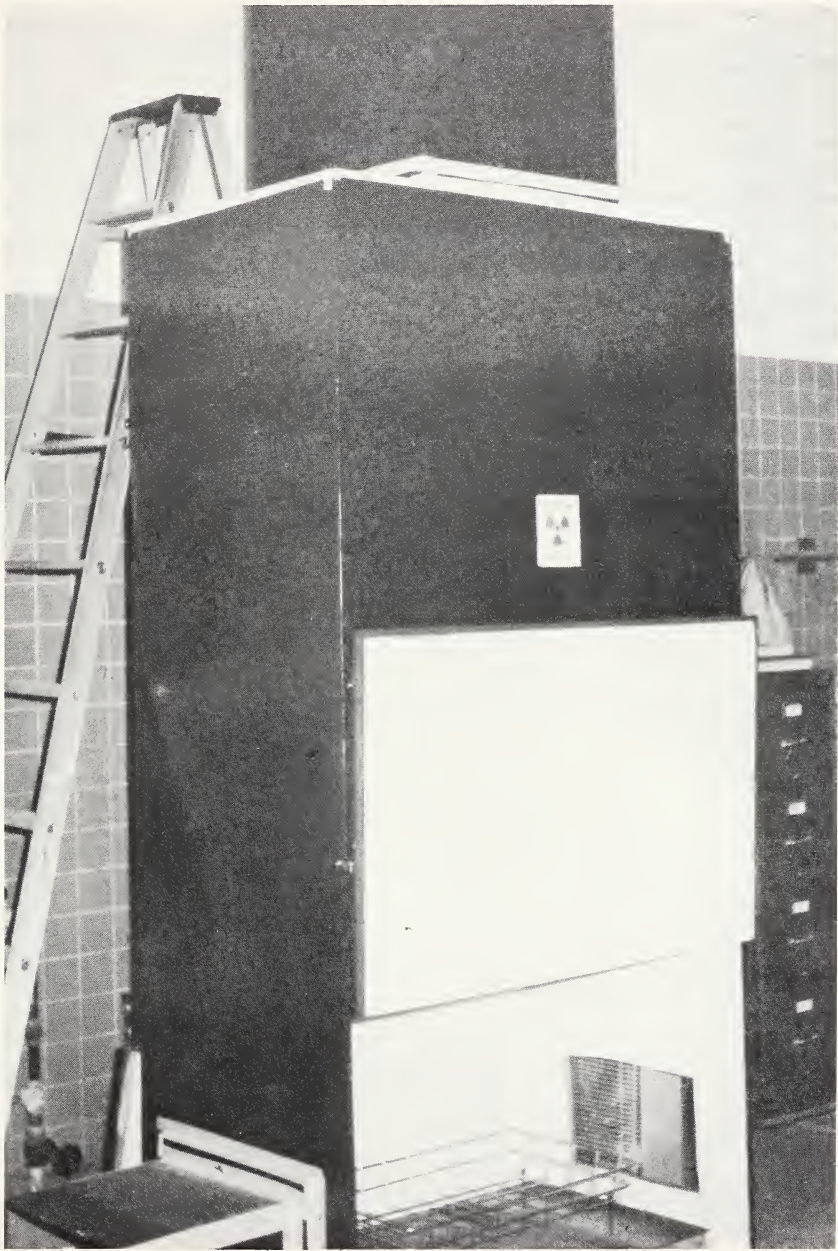

Fig. 1 Simulated-fallout exposure chamber.



Fig. 2 Microplot of grass in exposure chamber.

For the field studies circular plots 20 ft or more in diameter were fitted with greased disk impactors to monitor deposition (Fig. 3). The simulant was dispersed over a field plot from an elevated platform by means of a blower (Fig. 4). The actual release took place over a period of from 5 to 50 min depending on the stability of wind direction. Crop clippings taken at intervals over a 2-week period after contamination were counted by gamma spectrometry to reveal the retention functions (Fig. 5). Crops of eastern Colorado that were tested are alfalfa, corn, irrigated pasture brome grass, sudan grass, sugar beets, and barley.

Table 1 gives the conditions for the experiments of the 1969 crop year. Experimental results for two crop years are shown in Tables 2 to 6 and Figs. 6 and 7.

RESULTS AND DISCUSSION

Table 2a gives measured initial retention of near-in simulant on field crops. In most cases neither particle size nor loading in the ranges tested was important compared with the retention differences characteristic of the target species. Bulk contamination of alfalfa is typically 5 to 10%. Contamination of pasture grass under dry, windy exposure conditions is contrasted with much higher initial



Fig. 3 Field plot with deposition monitors.



Fig. 4 Gas-powered blower on dispersal tower.

retention under heavy dew. Retention by sudan grass is intermediate to that by brome grass and corn. Bulk contamination of corn (Table 2b) was not highest even though it retained most sand as a percent of ground-area deposition. Initial retention of 88- to 175- μ sand by sugar-beet tops (40%) was markedly higher than retention of 175- to 350- μ sand (4%). Retention was calculated on a plant-area basis rather than a ground-area basis for sugar beets only.

Table 3 shows weathering half-time of external contamination. The sand is lost from alfalfa with a half-time of about 1 week. Heavily laden pasture grass exposed under heavy dew had a 1-day half-time for about 3 days, after which further loss was barely detectable over 2 weeks. Young 2.5-ft-tall corn lost half of its simulated fallout in 6.5 days, whereas a more nearly mature 8-ft stand had a half-time of about 2 weeks. Weathering from sugar-beet tops proceeded with a half-time of 3 to 5 days for fine sand but was negligible for coarse sand, which was already at a low bulk level because of poor initial retention.



Fig. 5 Clipping of alfalfa within sampling ring.

Table 1
SUMMARY OF SECOND-CROP-YEAR EXPERIMENTAL RELEASES
ON FIELD CROPS

Experiment	Crop	Date	Time	Length of experiment, days	Sand size*	Distance from blower to plot center, ft
1	Alfalfa	6/24	1400	3	L	15
2	Alfalfa	6/26	1100	11	S	30 or 45
3	Corn	7/08	1630	24	L	30
4	Corn	7/08	1715	24	S	30
5	Barley	7/10	1710	17	L	25
6	Barley	7/11	1120	18	S	20
7	Sugar beets	7/29	1930	19	S	50
8	Sugar beets	7/30	1145	19	L	50
9	Corn	8/05	0935	16	L	20
10	Corn	8/05	1040	16	S	20
11	Bromegrass	8/07	1030	18	L	40 to 50
12	Bromegrass	8/08	1600	17	S	40 to 50
13	Alfalfa	8/19	1505	15	S	30
14	Alfalfa	8/19	1620	15	L	30
15	Alfalfa	8/26	1140	10	S	30
16	Alfalfa	8/28	1230	10	L	25
17	Bromegrass	9/11	0720	15	S	15 to 20
18	Bromegrass	9/11	0815	15	L	25
19	Sudan grass	9/16	1539	13	S	25
20	Sudan grass	9/17	1500	12	L	25

*Abbreviations are L, large (175 to 350 μ); and S, small (88 to 175 μ).

Figure 6 shows retention of 88- to 175- μ sand by an alfalfa plot. Figure 7 is another retention function, this time for irrigated pasture bromegrass. Both figures show step changes caused by rainstorms. Table 4 summarizes data on removal of sand by rainstorms. These limited data do not quantitate a relation of percent of loss to inches of rainfall. It is clear that the small amount of coarse sand retained initially is less disturbed by rain. Table 5 expresses wind weathering of sand from the crops as the product of half-time and average wind speed.

Table 6a shows the approach to assay of distribution of sand on plant parts. Only corn, barley, and sugar beets were sampled in this way. Table 6b indicates that corn initially held 10 to 20% of its fine sand and 50% of its coarse sand on leaves. At 9 days the figures were 5 to 10% for fine sand and 2 to 3% for coarse sand. On corn that had 14 to 18 segments, initial retention had broad maximums on descending segments 3 to 6 for 88- to 175- μ sand and segments 7 to 10 for 175- to 350- μ . At 16 days the maximum was indistinct for fine sand but had

Table 2a
INITIAL RETENTION OF EXTERNAL CONTAMINATION

Experiment	Wind, mph	Moisture	Sand size*	Initial retention		
				%	m ² /kg, wet	m ² /kg, dried
Alfalfa						
2	12 to 30		S	2	0.008	0.045
13	6		S	6.5	0.07	0.45
15	0 to 10		S	17	0.12	0.8
wa	None	Trace rain	S	23		
wb	0 to 20		S	7.2		
1	4	Dew	L	15	0.075	0.65
14	6		L	3	0.02	0.17
16	2 to 10		L	6	0.05	0.25
wc	None		L	5		
Bromegrass						
12	6		S	4.5	0.065	0.3
17	1 to 2	Heavy dew	S	100	1.2	6
wf	None		S	7.4		
11	7		L	0.4	0.0075	0.04
18	None	Heavy dew	L	85	0.8	3.5
wg		Trace rain	L	5.5		
Sudan Grass						
19	2 to 4		S	8.5	0.08	0.4
20	2 to 4		L	7.5	0.05	0.25

*Abbreviations are S, small (88 to 175 μ); and L, large (175 to 350 μ).

been sharpened for the coarse sand by loss from top segments. Barley heads (Table 6c) lost coarse sand to a noticeably greater extent in 17 days than did stems. Sugar-beet tops displayed a similar transfer from top to plant base for both sizes of sand.

Although it is not the intent of our project to engage in beta-dose calculations, we will briefly describe the manner of the use of our data for that purpose. Bulk contamination level, integrated over time, may yield total dose when related to other measurements on the radiations from particles in a given fallout field. Where meristematic or vegetative sensitivity warrants, adjusted local-structure excess beta dose based on distribution of retention at that location may be related to the radiation emission of sized particles, to the self-absorption by aggregations of particles, and to dose exchange among contaminated plant structures.

Table 2b

INITIAL RETENTION OF EXTERNAL CONTAMINATION

Experiment	Wind, mph	Moisture	Sand size*	Initial retention		
				%	m ² /kg, wet	m ² /kg, dried
Corn						
4	0 to 15		S	15	0.25	2.5
10	2		S	35	0.1	0.65
wd			S	44		
3	0 to 10		L	15	0.25	2.5
9	2		L	35	0.1	0.65
we			L	32		
Barley						
6	0 to 1		S	5.8	0.04	0.1
5	1 to 2		L	5.8	0.04	0.1
Sugar Beets						
7	4	Drizzle	S	40	0.25	3
8	7	H ₂ O drops	L	4	0.015	0.2

*Abbreviations are S, small (88 to 175 μ); and L, large (175 to 350 μ).

Table 3

WEATHERING TIME OF EXTERNAL CONTAMINATION

Retainer	Experiment	Half-time, days	
		88- to 175- μ sand	175- to 350- μ sand
Alfalfa	2, 1	10	Experiment cut short
	13, 14	7	7
	15, 16	6	6
Bromegrass	12, 11	1 day for 3 days, then 19 days	14
	17, 18	1 day for 3 days, then flat* for both sand sizes	
Sudan grass	19, 20	9.5	Flat*
Corn	4, 3	6.5	6.5
	10, 9	12	12
Barley	6, 5	11	11
Sugar beets	7, 8	3, before rain	Flat*
		5, after rain	

*Curve is relatively flat; half-time appears to be infinite.

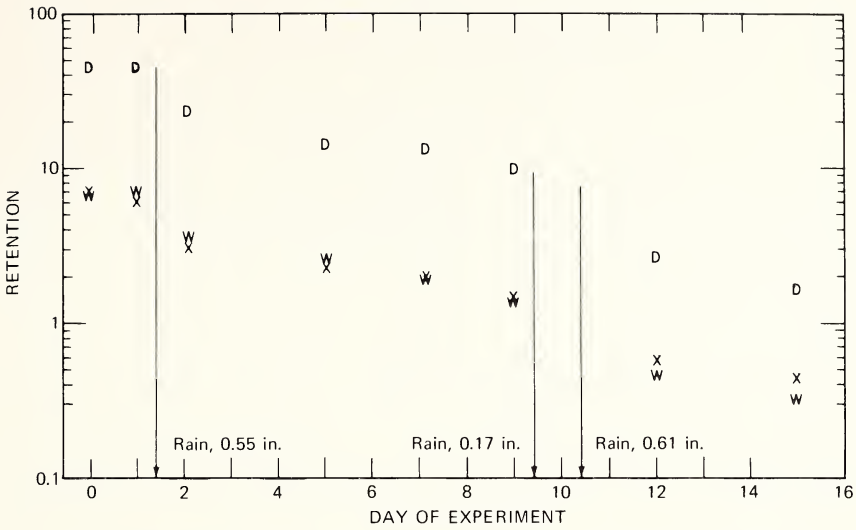

Fig. 6 Retention of 88- to 175- μ sand by a plot of alfalfa. X, percent retention; D, m^2/kg , dried, $\times 100$; W, m^2/kg , wet, $\times 100$.

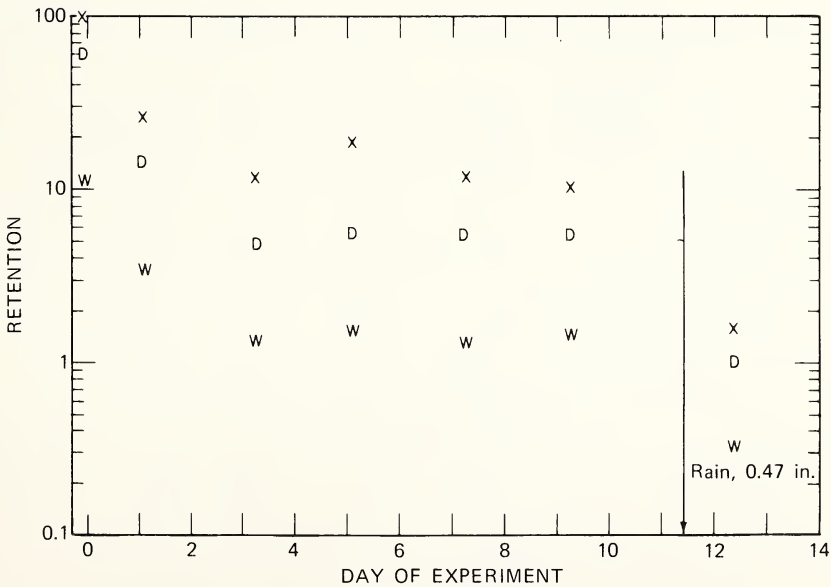

Fig. 7 Retention of 88- to 175- μ sand by a plot of irrigated pasture bromegrass. X, percent retention; D, m^2/kg , dried, $\times 10$; W, m^2/kg , wet, $\times 10$.

Table 4
RAIN WEATHERING OF SAND FROM CROPS

Crop	Length of experiment, days	Rain, in.	Median retention, %			
			88- to 175- μ sand		175- to 350- μ sand	
			Before weathering	After weathering	Before weathering	After weathering
Alfalfa	3	0.77	*	*	*	*
	10		1.2	0.6	*	*
Bromegrass	10	0.47	8	3	*	*
Sudan grass	5	0.47	6	4	6	4
Corn	6	0.25 and hail	8.5	3	8.5	3
Barley	4	0.25 and hail†	*	*	*	*
Sugar beets	5	0.38	20	10	*	*

*Little effect.

†Part of fields.

Table 5
WIND WEATHERING OF SAND FROM CROPS

Crop	Number of monitored releases	Sand size*	Half-time (T/2), days	T/2 \times MPH†	
				MPH*	T/2 \times MPH†
Alfalfa	2	S	6.5	2.2	14.3
	2	L			
Bromegrass	2	S	1, 19	2.2	2.2, 41.8
	2	L	1, flat‡		2.2, large
Sudan grass	1	S	9.5	1.8	17.1
	1	L	Flat‡		Large
Corn	2	S, L	6.5	1.2	7.8
	2	S, L	>12	3.9	>46.8
Barley	1	S	11	1.8	19.8
	1	L			
Sugar beets	1	S	4	3.2	12.8
	1	L	Flat‡	3.2	Large

*Abbreviations are S, small (88 to 175 μ); and L, large (175 to 350 μ).

†MPH is average wind speed.

‡Curve is relatively flat; half-time appears to be infinite.

Table 6a
 SAMPLING OF DISTRIBUTION OF SAND
 ON PLANT PARTS

Crop	Localization distribution
Corn	Two-segment lengths, stem and leaf Stems with leaf angles vs. bodies of leaves
Barley	Heads vs. stems
Beet	Tops vs. bases
Alfalfa	Not fractionated
Bromegrass	Not fractionated

Table 6b
 REDISTRIBUTION OF SAND ON CORN BY WEATHERING

Sand size, μ	Experiment	Retention
Segmental Distribution on 14-Segment Stalks		
88 to 175	10	Broad maximum (2 x top segments), maximum 3 to 6 segments from top
175 to 350	9	Broad maximum (3 x top segments), maximum 7 to 10 segments from top
Leaf Vs. Leaf + Stem with Leaf Angle		
		Start 9 days
88 to 175	10	0.2 0.03
	4	0.1 0.02
175 to 350	9	0.5 0.05
	3	0.5 0.1

Table 6c
 REDISTRIBUTION OF SAND BY WEATHERING

Sand size, μ	Experiment	Retention, fraction		
		Initial	17 days	19 days
Barley, Heads Vs. Heads + Stems				
88 to 175	6	0.8	0.7	
175 to 350	5	0.9	0.3	
Sugar Beets, Tops Vs. Tops + Base				
88 to 175	7	0.9		0.1
175 to 350	8	0.2		0.03

SUMMARY

We have presented data on initial retention and weathering of simulated near-in fallout particles from alfalfa, corn, barley, irrigated pasture bromegrass, sudan grass, and sugar-beet tops. Initial retention of the particles ranged from complete to practically no retention, depending on weather conditions at the time of exposure and on the plant structure. Observed weathering half-times were from 1 day or less to more than 2 weeks. The data may be applied to calculate bulk contamination of forage and radiation dose to growing plants.

ACKNOWLEDGMENTS

This study is supported by the Office of Civil Defense under contract DAH20-68-C-0120. D. W. Wilson was the original principal investigator of the project.

REFERENCES

1. S. L. Brown and V. F. Pilz, U. S. Agriculture: Potential Vulnerabilities, SRI Project No. MU-6250-052, Stanford Research Institute, January 1969.
2. M. C. Bell and C. V. Cole, Vulnerability of Food Crop and Livestock Production to Fallout Radiation, USAEC Report TID-24459, UT-AEC Agricultural Research Laboratory, Sept. 7, 1967.
3. C. F. Miller, Operation Ceniza-Arena: The Retention of Fallout Particles from Volcan Irazu (Costa Rica) by Plants and People. Part III, Report AD-673202, Stanford Research Institute, December 1967.
4. G. M. Dunning, Health Aspects of Nuclear Weapons Testing, USAEC Report TID-20723, U. S. Atomic Energy Commission.
5. D. E. Clark and W. C. Cobbin, Some Relationships Among Particle Size, Mass Level, and Radiation Intensity of Fallout from a Land Surface Nuclear Detonation, Report USNRDL-TR-639, Naval Radiological Defense Laboratory, Mar. 21, 1963.
6. W. B. Lane, Fallout Simulant Development, Final Report to OCD, Stanford Research Institute, September 1969.

PREDICTION OF SPECIES RADIOSENSITIVITY

HARVEY L. CROMROY, RICHARD LEVY, ALBERTO B. BROCE, and
LEONARD J. GOLDMAN

Departments of Entomology and Radiology, Division of Nuclear Sciences,
University of Florida, Gainesville, Florida

ABSTRACT

A study was made on the feasibility of using the mammalian columnar epithelial cell of the duodenum and the insect endothelial cell of the midgut as biological indicators of radiation sensitivity. Thirty species of mammals and twenty species of insects were used. Data demonstrating situations where the respective cells would be most useful as parameters for radiosensitivity are presented.

The major aim of our research was to determine biological indicators that could serve as predictors of radiation sensitivity.

Previous research by Sparrow and co-workers¹⁻³ established that the radiosensitivities of plants to ionizing radiation could be predicted on the basis of a regression line measured by the interphase chromosome volume (ICV) against the lethal dose required to kill 50% of a given population (LD_{50}) for established irradiated species. The ICV was defined as the nuclear volume of a cell divided by the diploid chromosome number of the species. Conger,⁴ who initiated this research project, further substantiated this hypothesis with his work on Florida gymnosperms. We began our research to determine whether this type of correlation also exists in insects and mammals. The biological-indicator cells, selected because of their established sensitivity to ionizing radiation, were the endothelial cells lining the midgut of insects and the columnar epithelial cells of the duodenal intestinal mucosa of mammals.

The initial publication was on seven species of mammals and eight species of insects.⁵ At that time it was reported that the mammalian species studied had a slope with a positive declination, whereas the insects had a negative declination to the slope conforming with Sparrow's previous work.³ Simply, the mammalian

slope indicated that the larger the ICV, the less sensitive the animal was to ionizing radiation; the inverse relation holds true for insects and plants. Later research amplified the data to include 22 species of mammals and 11 species of insects. We found contradictions within the mammals, in the rodent species in particular, which presented a number of problems.

Our current data on 20 species of insects and 30 species of mammals are presented here. For purposes of clarity this paper is subdivided into two sections; the first deals with mammals and the second with insects.

MAMMALS

The order Rodentia presented so much scatter when included with the other orders of mammals that we arbitrarily lumped all rodent data together.

Mammals Other Than Rodents

The data in Fig. 1 are for the midline air dose in roentgens with a 1-MVp X-ray unit. The LD_{50} 's, except the one for sheep, were done at the Naval Radiological Defense Laboratory, San Francisco, Calif., by Ainsworth et al.⁶ The data on sheep were obtained through the cooperation of the Radiobiology Laboratory, Biophysics Branch, Air Force Weapons Laboratory, Kirtland Air

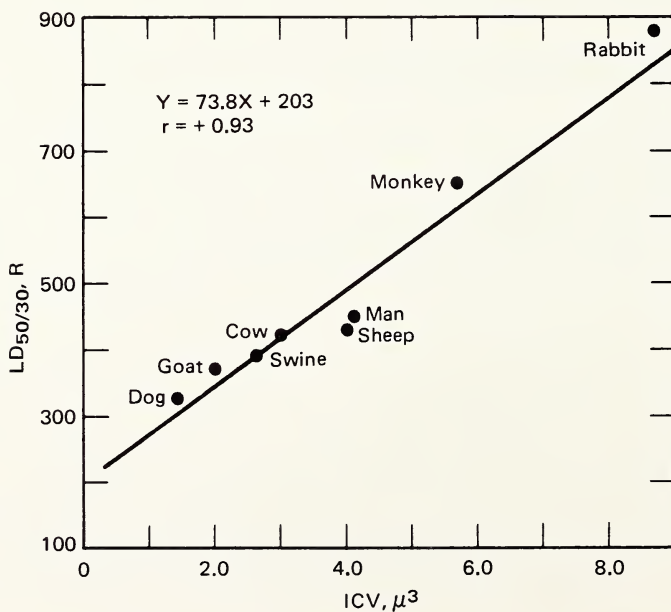

Fig. 1 Relation of interphase chromosome volume to $LD_{50/30}$ exposure dose (midline air dose with 1-MVp X ray) in mammals other than rodents.

Force Base, N. Mex. The regression equation, or predictor formula, is $Y = 74X + 203$, where Y is $LD_{50/30}$ days in roentgens, midline air dose, and X is ICV. The coefficient of correlation, r , is $+0.93$, where r indicates a linear relation between points. If r equals ± 1 , a perfect correlation exists. A high value for r indicates that this is an excellent predictor for X radiation and exposure considerations only.

Rodents

Figure 2 presents an analysis of 11 species of rodents. The ICV's presented are the average of the male and female of the species, and the $LD_{50/30}$'s were taken from the literature.⁷⁻¹³ The three families of rodents represented are Muridae, Cricetidae, and Heteromyidae. The analysis of points by least squares has a slope equation of $Y = 122X + 688$, where Y is the $LD_{50/30}$ absorbed dose

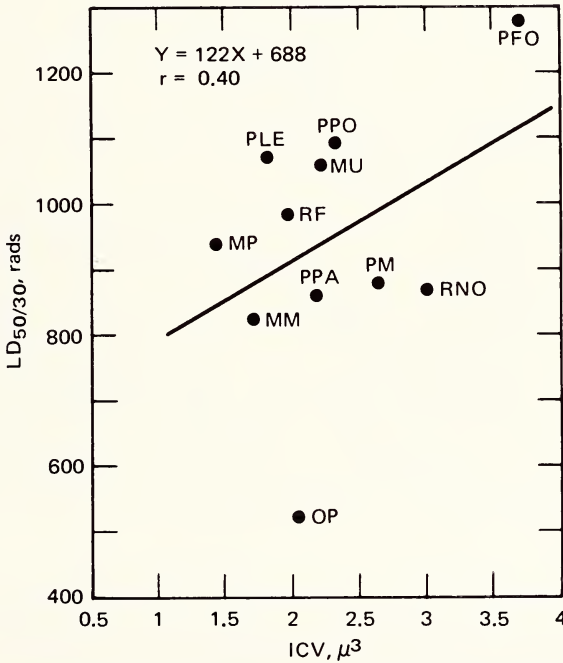

Fig. 2 Relation of interphase chromosome volume to $LD_{50/30}$ absorbed dose for rodent species. •, average ICV for male and female of species.

- | | |
|----------------------------------|-------------------------------------|
| MM, <i>Mus musculus</i> | PM, <i>Peromyscus maniculatus</i> |
| MP, <i>Microtus pinetorum</i> | PPA, <i>Perognathus parvus</i> |
| MU, <i>Meriones unguiculatus</i> | PPO, <i>Peromyscus polionotus</i> |
| OP, <i>Oryzomys palustris</i> | RF, <i>Mus musculus</i> , RF strain |
| PFO, <i>Perognathus formosus</i> | RNO, <i>Rattus norvegicus</i> |
| PLE, <i>Peromyscus leucopus</i> | |

in rads from ^{60}Co and X is the ICV. The coefficient r is $+0.40$. This figure is strongly influenced by points OP and PFO. Removal of these two points would change the analysis considerably.

Figure 3 is a graphical representation of the analysis of 13 different species of male rodents. The ICV's plotted are for males only. Again there is a positive declination to the slope and a high degree of scatter. The predictor equation is $Y = 152X + 544$, and r equals $+0.46$.

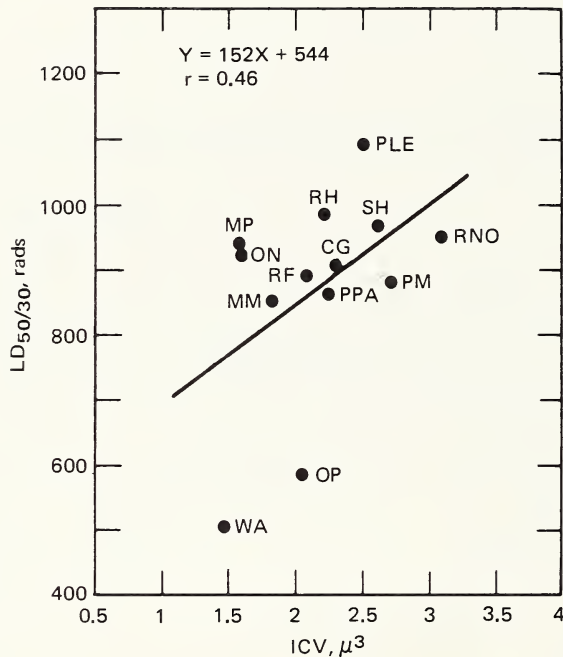

Fig. 3 Relation of interphase chromosome volume of male rodent species to $LD_{50/30}$ absorbed dose.

- | | |
|-----------------------------------|-------------------------------------|
| CG, <i>Cricetulus griseus</i> | PPA, <i>Perognathus parvus</i> |
| MM, <i>Mus musculus</i> | RF, <i>Mus musculus</i> , RF strain |
| MP, <i>Microtus pinetorum</i> | RH, <i>Reithrodontomys bumilis</i> |
| ON, <i>Ochrotomys nuttalli</i> | RNO, <i>Rattus norvegicus</i> |
| OP, <i>Oryzomys palustris</i> | SH, <i>Sigmodon hispidus</i> |
| PLE, <i>Peromyscus leucopus</i> | WA, <i>Rattus rattus</i> , Wistar |
| PM, <i>Peromyscus maniculatus</i> | Albino strain |

Figure 4 pictures the analysis of 12 different female rodent species. There is a negative declination to the slope, indicating an inverse relation to the slope obtained with male rodents. In this case the predictor equation is $Y = -137X + 1102$, and r is -0.46 . Therefore the contribution from the male species is the factor that accounts for the positive slope obtained in Fig. 2.

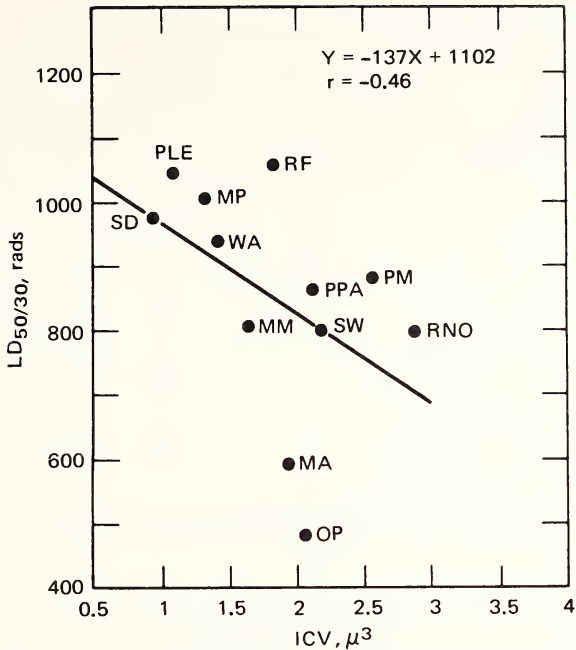

Fig. 4 Relation of interphase chromosome volume of female rodent species to LD_{50/30} absorbed dose.

MA, *Mesocricetus auratus*
 MM, *Mus musculus*
 MP, *Microtus pinetorum*
 OP, *Oryzomys palustris*
 PLE, *Peromyscus leucopus*
 PM, *Peromyscus maniculatus*
 PPA, *Perognathus parvus*
 RF, *Mus musculus*, RF strain

RNO, *Rattus norvegicus*
 SD, *Rattus rattus*, Sprague
 Dawley strain
 SW, *Mus musculus*, Swiss
 Webster strain
 WA, *Rattus rattus*, Wistar
 Albino strain

Table 1 presents a comparison of male and female ICV's. The male almost always has a larger ICV than the female, but the LD_{50/30} of the male may be larger or smaller than that of the female. This causes the poor predictive values for the species.

Figure 5 compares Fry's data¹⁴ on mean survival times for massive doses of whole-body irradiation with our ICV data. A negative slope is obtained, with $Y = -61X + 264$ and $r = -0.65$; this indicates a much better correlation between points. If we combine Fry's data and those of Dunaway et al.,⁹ we obtain the slope shown in Fig. 6. In this case, $Y = 0.40X + 215$, and r equals -0.68 . Table 2 compares the observed and the predicted mean survival times (MST). This relation appears to be much more valid for predictive purposes.

TABLE 1
COMPARISON OF MALE AND FEMALE RODENT ICV AND LD_{50/30}

Species	Sex	ICV	Observed	Predicted
			LD _{50/30} , rads*	LD _{50/30} , radst
<i>Rattus norvegicus</i>	f	2.88	949	707
	m	3.07	795	1011
<i>Mus musculus</i>	f	1.62	802	880
	m	1.81	851	818
<i>Peromyscus leucopus</i>	f	1.07	1043	955
	m	2.50	1091	924
<i>Microtus pinetorum</i>	f	1.30	1004	924
	m	1.52	883	775
<i>Oryzomys palustris</i>	f	2.04	484	823
	m	2.02	584	848

*Data are taken from Dunaway et al.⁸

†Predicted value is taken from either Fig. 3 or Fig. 4, depending on sex.

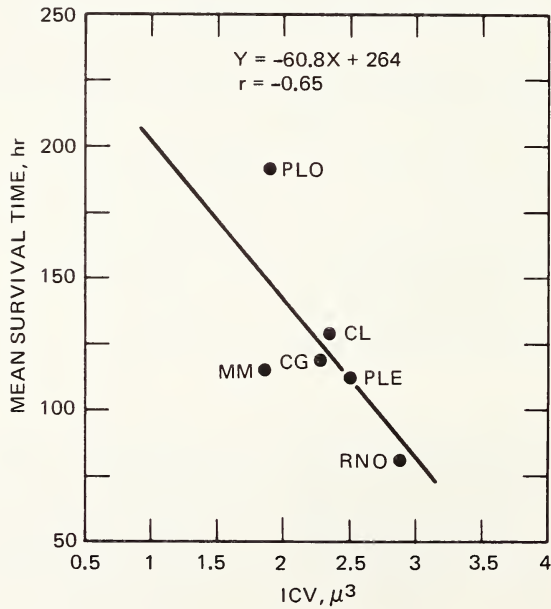

Fig. 5 Relation of interphase chromosome volume to mean survival time of mammals exposed to large doses of whole-body irradiation.

CG, *Cricetulus griseus*

CL, *Chinchilla laniger*

MM, *Mus musculus*

PLE, *Peromyscus leucopus*

PLO, *Perognathus longimembris*

RNO, *Rattus norvegicus*

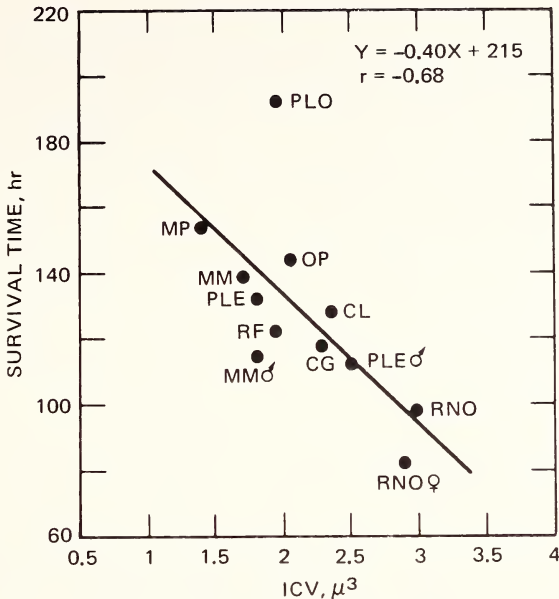

Fig. 6 Relation of interphase chromosome volume to mean survival time of mammals exposed to large doses of whole-body irradiation.

CG, *Cricetulus griseus*

CL, *Chinchilla laniger*

MM, *Mus musculus*

MP, *Microtus pinetorum*

OP, *Oryzomys palustris*

PLE, *Peromyscus leucopus*

PLO, *Perognathus longimembris*

RF, *Mus musculus*, RF strain

RNO, *Rattus norvegicus*

Discussion of Results

Table 3 summarizes the predictor equations and coefficients for Figs. 1 to 6. As can be seen, the slope for data from mammals other than rodents is the best predictor; its very high coefficient indicates a good degree of reliability. The work with $LD_{50/30}$ and ICV in rodent species is still unsatisfactory. The scatter plus the positive slope for the males vs. the negative slope for the females makes predictability inaccurate. Part of the problem is undoubtedly the fact that the $LD_{50/30}$ data were taken from the literature, and consequently different dose rates were used to obtain the respective $LD_{50/30}$'s. It may well be that the new formula suggested by Dunaway et al.⁹ [$Y = 20.75X - 2.77$, where Y is rads per gram and X is red blood cell count/ $(2\pi r)$ intestine] may be one of the better rough predictors of $LD_{50/30}$.

Before the rodent data can have any validity as a predictor for $LD_{50/30}$, much more study must be done on the parameters affecting the radiation sensitivity of the species. It appears that the use of the ICV for mean-survival-time predictions is good since this provides good estimates.

TABLE 2
COMPARISON OF MEAN SURVIVAL TIMES (MST) FOR LARGE DOSES
OF WHOLE-BODY RADIATION WITH ICV IN RODENTS

Species*	ICV	Observed MST, hr	Predicted MST, hr
<i>Perognathus longimembris</i> , average	1.95	192	136
<i>Peromyscus leucopus</i> , male	2.50	112	113
<i>Peromyscus leucopus</i> , average	1.80	132	142
<i>Cricetulus griseus</i> , male	2.28	118	122
<i>Rattus norvegicus</i> , male	2.88	82	98
<i>Mus musculus</i> , male	1.80	115	142
<i>Chinchilla laniger</i> , male	2.35	128	119
<i>Microtus pinetorum</i> , average	1.41	154	157
<i>Oryzomys palustris</i> , average	2.03	144	132
<i>Mus musculus</i> , RF strain, average	1.95	122	136
<i>Rattus norvegicus</i> , average	2.98	98	94
<i>Mus musculus</i> , average	1.71	139	145

*The term "average" after species indicates that the ICV given is the average of the values for the male and female of the species.

TABLE 3
SUMMARY OF THE PREDICTOR EQUATIONS AND THEIR
COEFFICIENTS FOR FIGS. 1 TO 6

Figure	Predictor	Coefficient
Fig. 1, Mammals other than rodents	$Y = 73.8X + 203$	$r = +0.93$
Fig. 2, ICV with LD ₅₀ in rodents	$Y = 122X + 688$	$r = +0.40$
Fig. 3, ICV with LD ₅₀ in male rodents	$Y = 152X + 544$	$r = +0.46$
Fig. 4, ICV with LD ₅₀ in female rodents	$Y = -137X + 1102$	$r = -0.46$
Fig. 5, MST with ICV	$Y = -61X + 264$	$r = -0.65$
Fig. 6, MST with ICV	$Y = -40X + 215$	$r = -0.68$

INSECTS

Our initial studies on insects were done with 11 species. The LD₅₀ was taken for 24 hr and the biological indicator cell was the endothelial cell lining the midgut. A 24-hr period was selected on the basis of the large variation in life-spans of insects and the requirements of culture rooms for sustained life-history studies. The 11 species studied gave a predictor formula of $Y = 2.67X + 163.42$, where Y is LD_{50/24 hr} in roentgens and X is the ICV.

Figure 7 presents a graphical analysis of 17 species of insects, the majority of which were irradiated with ^{60}Co at identical dose rates with three replications per point for verification of LD_{50} . All insects were in the adult stage and were of the orders Coleoptera, Diptera, Orthoptera, Hemiptera, Homoptera, and Anoplura. There is a negative declination to the slope; Y equals $-4.06X + 184$, and r equals -0.46 . This agrees with Sparrow's data³ indicating that the larger

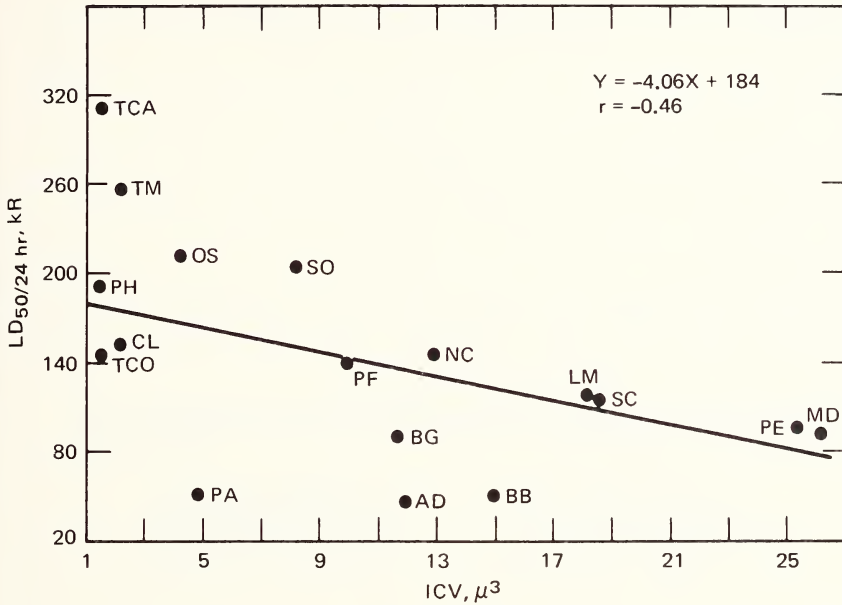

Fig. 7 Relation of interphase chromosome volume of 17 species of insects to $\text{LD}_{50/24}$ hr exposure dose (^{60}Co irradiation).

AD, <i>Acheta domestica</i>	PE, <i>Prodenia eridenia</i>
BB, <i>Brevicoryne brassicae</i>	PF, <i>Periplaneta fuliginosa</i>
BG, <i>Blatella germanica</i>	PH, <i>Pediculus humanus humanus</i>
CL, <i>Cimex lectularis</i>	SC, <i>Stomoxys calcitrans</i>
LM, <i>Leucophaea maderae</i>	SO, <i>Sitophilus oryzae</i>
MD, <i>Musca domestica</i>	TCA, <i>Tribolium castaneum</i>
NC, <i>Nauphoeta cinerea</i>	TCO, <i>Tribolium confusum</i>
OS, <i>Oryzaephilus surinamensis</i>	TM, <i>Tenebrio molitor</i>
PA, <i>Periplaneta americana</i>	

the ICV, the more sensitive the insect species is to ionizing radiation. In Fig. 8 the Orthopteran species are analyzed separately. Note that a positive slope is obtained; however, r is $+0.12$, indicating a very poor linear relation between points. For the Coleopteran species, Fig. 9, nuclear volume is plotted against $\text{LD}_{50/24}$ hr because so few chromosome numbers are available for many of the beetles. A negative, declining slope is obtained, and r equals -0.27 . This is also a

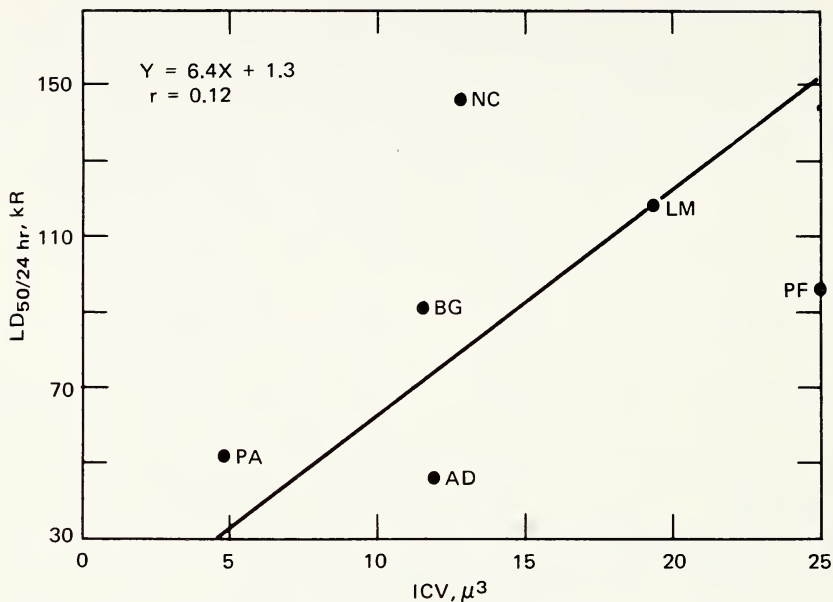

Fig. 8 Relation of interphase chromosome volume of Orthopteran species to LD_{50/24} hr exposure dose.

AD, *Acheta domestica*

BG, *Blatella germanica*

LM, *Leucophaea maderae*

NC, *Nauphoeta cinerea*

PA, *Periplaneta americana*

PF, *Periplaneta fuliginosa*

poor indication of linear relation between points. Plotting the dose required to reduce the life-span of the insect species by one-half under laboratory conditions against the ICV gives the curve shown in Fig. 10. The predictor equation is $Y = -0.73X + 11.04$, where Y is dose in kiloroentgens required to reduce life-span 50%. In this case r is -0.72 ; this indicates a high linear relation between points, and good predictive values are obtained. The dose data used in Figs. 10 and 11 are extrapolated from a series of research reports by other workers.¹⁵⁻²¹ Figure 11 compares LD_{50/28} days in kilorads and ICV. The predictor equation is $Y = -0.89X + 12$, where Y is LD_{50/28} day dose in kilorads and r is -0.82 .

Discussion of Results

The data on insects appear to be best when either life-span shortening or LD_{50/28} days is considered. In all probability the life-span shortening parameter will turn out to be best since there is such considerable variation in insect life-spans; for example, the American cockroach¹⁵ has a life-span of approximately 400 days under laboratory conditions, whereas the house fly¹⁶ has a life-span of only 25 days. The overall graph of 17 species is not so good a

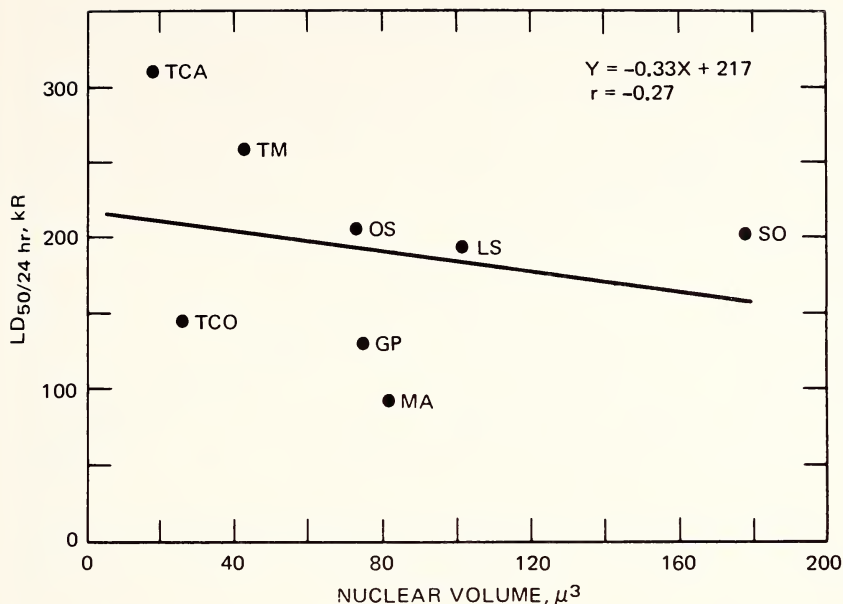

Fig. 9 Relation of nuclear volume of Coleopteran species to $LD_{50/24 \text{ hr}}$ exposure dose.

GP, <i>Gibbium psylloides</i>	SO, <i>Sitophilus oryzae</i>
LS, <i>Lasioderme serricornis</i>	TCA, <i>Tribolium castaneum</i>
MA, <i>Mezium americanum</i>	TCO, <i>Tribolium confusum</i>
OS, <i>Oryzaephilus surinamensis</i>	TM, <i>Tenebrio molitor</i>

predictor as was expected; there are several explanations for this, however. Preliminary cytogenetic investigations by several authors^{19,20} showed the existence of unique chromosome structures in different orders of insects, such as chromosomes with diffuse centromeres or polycentric chromosomes (i.e., each chromosome has more than one region for spindle fiber attachment). If polycentric chromosomes are subjected to ionizing radiation, the chromosome fragments produced will very likely possess at least one centromere and thus could function as independent chromosomes; this would reduce the probability of lethal mutations. The rate of deoxyribonucleic acid turnover in the midgut is another factor since the true plant feeders may differ considerably from the seed and grain feeders as well as from the blood feeders. Since the mechanisms by which radiation produces mortality in insects are still largely undetermined, selection of the proper parameter as an end-point measurement of radiation sensitivity presents many problems. A number of other parameters that have been used in estimating radiosensitivity of insects include:

1. Body weight. The larger the insect, the lower the dose required to kill.

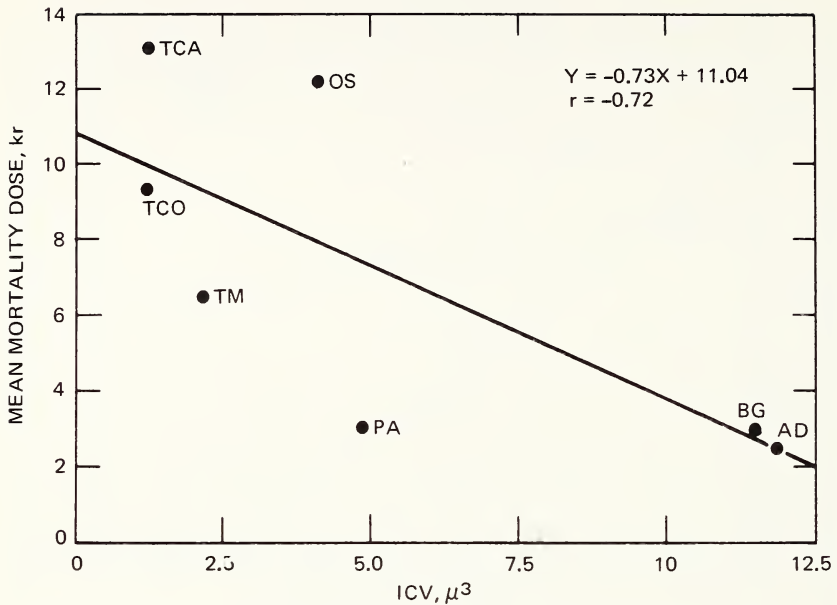

Fig. 10 Relation of insect interphase chromosome volume to $LD_{50/28}$ day dose.

AD, *Acheta domestica*

BG, *Blatella germanica*

OS, *Oryzaephilus surinamensis*

PA, *Periplaneta americana*

TCA, *Tribolium castaneum*

TCO, *Tribolium confusum*

TM, *Tenebrio molitor*

2. Phylogenetic relations.

3. Physical activity. This is a difficult parameter to quantify.

4. Life-span. Longer-living insects are supposed to be more sensitive to ionizing radiation.

We believe that the best predictor formula will probably be a combination of several of these parameters combined with interphase nuclear volume.

SUMMARY

Mammalian species other than rodents provide the best predictor slope for $LD_{50/30}$ exposure doses. The interphase chromosome volume for rodents is useful as a predictor only when we are dealing with the gastrointestinal form of death measured in mean survival time. The amount of scatter in rodent species obtained with the ICV's makes them questionable as the sole predictor sources for $LD_{50/30}$.

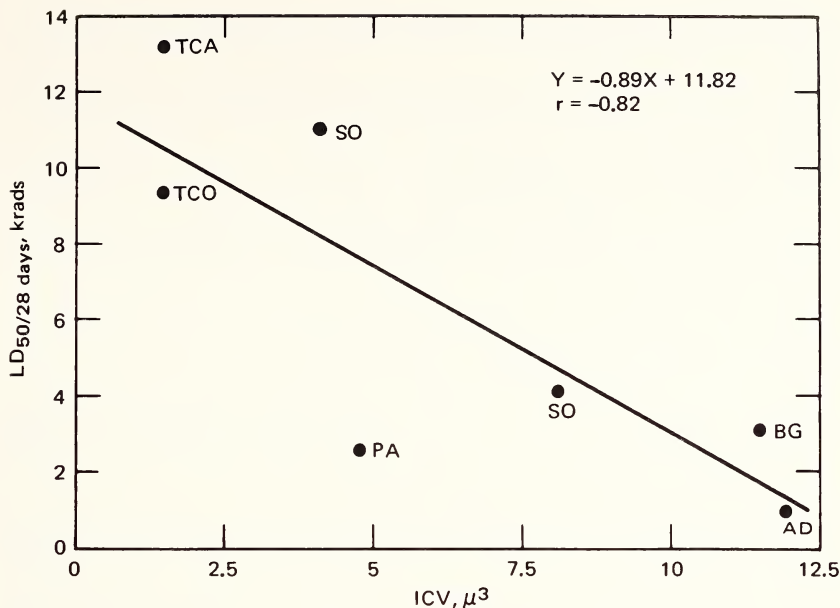

Fig. 11 Relation of interphase chromosome volume of insects to mean mortality expressed as kilorad dose required to reduce life-span by one-half.

AD, *Acheta domestica*

BG, *Blatella germanica*

OS, *Oryzaephilus surinamensis*

PA, *Periplaneta americana*

SO, *Sitophilus oryzae*

TCA, *Tribolium castaneum*

TCO, *Tribolium confusum*

The interphase chromosome volume serves as a good predictor when we are considering LD₅₀/28 days or mean mortality in insects. It is not so good when we are dealing with LD₅₀/24 hr.

ACKNOWLEDGMENTS

This research was supported by the Office of Civil Defense.

Many of the specimens used were obtained through the cooperation of Paul Dunaway, Ecological Sciences Division, Oak Ridge National Laboratory; T. J. O'Farrell, Battelle-Northwest; R. J. M. Fry, Argonne National Laboratory; Norman French, Laboratory of Nuclear Medicine and Radiation Biology, University of California; and M. Kinsella, Veterinary Sciences Division, University of Florida.

REFERENCES

1. A. H. Sparrow and H. T. Evans, Nuclear Factors Affecting Radiosensitivity. I, The Influence of Nuclear Size and Structure, Chromosome Complement, and DNA Content,

- in Fundamental Aspects of Radiosensitivity, Report of a Symposium, June 5-7, 1961, Upton, N. Y., USAEC Report BNL-675, pp. 76-100, Brookhaven National Laboratory, 1961.
2. A. H. Sparrow, L. A. Schairer, and R. C. Sparrow, Relationship Between Nuclear Volume, Chromosome Numbers, and Relative Radiosensitivities, *Science*, **141**: 163-166 (1963).
 3. A. H. Sparrow, A. G. Underbrink, and R. C. Sparrow, Chromosomes and Cellular Radiosensitivity. 1. The Relationship of D_0 to Chromosome Volume and Complexity in Seventy-Nine Different Organisms, *Radiat. Res.*, **32**: 915-945 (1967).
 4. A. D. Conger and H. L. Cromroy, Radiosensitivity and Nuclear Volume in the Gymnosperms, Report OCD-PS-64-69, Office of Civil Defense, University of Florida, 1966.
 5. H. L. Cromroy, Cellular Response to Radiation, Report TRC-67-40, Office of Civil Defense, University of Florida, 1967.
 6. E. J. Ainsworth, N. P. Page, J. F. Taylor, G. F. Leong, and E. T. Still, Dose-Rate Studies with Sheep and Swine, in The Proceedings of a Symposium on Dose Rate in Mammalian Radiation Biology, Apr. 29-May 1 1968, Oak Ridge, Tenn., D. G. Brown, R. G. Cragle, and T. R. Noonan (Eds.), USAEC Report CONF-680410, pp. 4.1-4.21, UT-AEC Agricultural Research Laboratory, July 12, 1968.
 7. W. F. Belk and A. E. Gass, Jr., Relative Resistance of Gerbils and Rats to Acute Cobalt-60 Irradiation, Report SAM-TR-69-16, School of Aerospace Medicine, Brooks AFB, Texas, 1969.
 8. P. B. Dunaway, L. L. Lewis, L. D. Story, J. A. Payne, and J. M. Inglis, Radiation Effects in the Soricidae, Cricetidae, and Muridae, in Symposium on Radioecology, Proceedings of the 2nd National Symposium May 15-17, 1967, Ann Arbor, Mich., D. J. Nelson and F. C. Evans, (Eds.), USAEC Report CONF-670503, pp. 173-184, AEC Division of Biology and Medicine and Ecological Society of America, March 1969.
 9. P. B. Dunaway, J. T. Kitchings III, J. D. Story, L. E. Tucker, and H. F. Landreth, in Health Physics Division Annual Progress Report for Period Ending July 31, 1969, USAEC Report ORNL-4446, pp. 63-65, Oak Ridge National Laboratory, October 1969.
 10. F. B. Golley and J. B. Gentry, Response of Rodents to Acute Gamma Radiation Under Field Conditions, in Symposium on Radioecology, Proceedings of the 2nd National Symposium May 15-17, 1967, Ann Arbor, Mich., D. J. Nelson and F. C. Evans, (Eds.), USAEC Report CONF-670503, pp. 166-172, AEC Division of Biology and Medicine and Ecological Society of America, March 1969.
 11. Thomas P. O'Farrell, Effects of Acute Ionizing Radiation in Selected Pacific Northwest Rodents, in Symposium on Radioecology, Proceedings of the 2nd National Symposium, May 15-17, 1967, Ann Arbor, Mich., D. J. Nelson and F. C. Evans, (Eds.), USAEC Report CONF-670503, pp. 157-165, AEC Division of Biology and Medicine and Ecological Society of America, March 1969.
 12. W. H. Pryor, Jr., W. G. Glenn, and K. A. Hardy, The Gamma Radiation $LD_{50(30)}$ for the Rabbit, *Radiat. Res.*, **30**: 483-487 (1967).
 13. J. E. Traynor and E. I. Still, Dose Rate Effect on $LD_{50/30}$ in Mice Exposed to Cobalt-60 Gamma Irradiation, Report SAM-TR-68-97, School of Aerospace Medicine, Brooks AFB, Texas, 1968.
 14. R. J. Michael Fry, A. B. Rieskin, W. Kiseleski, A. Sallese, and E. Staffeldt, in *Comparative Cellular and Species Radiosensitivity*, V. P. Bond and T. Sugahara (Eds.), pp. 255-268, Igaku Shoin Ltd., Tokyo, 1969.
 15. M. M. Cole, G. C. La Breque, and G. S. Burden, Effect of Gamma Radiation on Some Insects Affecting Man, *J. Econ. Entomol.*, **52**: 448-450 (1959).

16. J. M. Cork, Gamma-Radiation and Longevity of the Flour Beetle, *Radiat. Res.*, **7**: 551-557 (1957).
17. P. B. Cornwell (Ed.), *The Entomology of Radiation Disinfestation of Grain*, pp. 1-17, 119-141, Pergamon Press, Inc., New York, 1966.
18. E. F. Menhinick and D. A. Crossley, Jr., A Comparison of Radiation Profiles of *Acheta domestica* and *Tenebrio molitor*, *Ann. Entomol. Soc. Amer.*, **61**: 1359-1365 (1968).
19. E. F. Menhinick and D. A. Crossley, Jr., Radiation Sensitivity of Twelve Species of Arthropods, *Ann. Entomol. Soc. Amer.*, **62**: 711-717 (1969).
20. D. T. North and G. G. Holt, in *Isotopes and Radiation in Entomology*, Symposium Proceedings, Vienna, 1967, pp. 391-403, International Atomic Energy Agency, Vienna, 1968 (STI/PUB/166).
21. E. W. Tilton, W. E. Burkholder, and R. R. Cogburn, Effects of Gamma Radiation on *Rhyzopertba dominica*, *Sitophilus oryzae*, *Tribolium confusum*, and *Lasioderma serricorne*, *J. Econ. Entomol.*, **59**: 1363-1368 (1966).

ADDITIONAL READING LIST

- Cromroy, H. L., Cellular Indicators of Radiosensitivity, OCD Report TRC-68-49, University of Florida, 1969.
- Cromroy, H. L., Mammalian Radiosensitivity, OCD Report TO-3140-(68), University of Florida, 1969.

INSECT-INDUCED AGROECOLOGICAL IMBALANCES AS AN ANALOG TO FALLOUT EFFECTS

VERNON M. STERN

Department of Entomology, University of California, Riverside, California

ABSTRACT

Many species in the classes Insecta and Arachnida are phytophagous and compete with man and his domestic animals for food, and others attack man and animals directly or transmit plant and animal diseases. On the other hand, there are tremendous numbers of beneficial species; among them are plant pollinators, insects that aid in the decomposition and recycling of plant and animal debris, and thousands of other beneficial insects and mites that attack and kill the destructive species. Crop losses from insects amount to nearly \$4 billion annually. Control measures (mainly chemicals) for crop protection in the field and for stored crop products cost nearly \$750 million annually. Many insect-pest populations rise to damaging levels year after year in agroecosystems although this is rather uncommon in natural communities. The monoculture is a special type of agroecosystem resulting from man's technical efforts to control nature to meet his need for food and other products. It is somewhat doubtful whether we can change the monoculture into a more diversified agroecosystem despite the annual plagues of insect pests. Fallout radiation is somewhat similar to the pesticides that often cause ecological disruptions. Even though pest insects may be eliminated from certain areas by fallout radiation, they can be expected to become reestablished in these areas soon and again to compete with man for his food. For these and other reasons discussed, both beneficial and pest species will be important factors in food production in the event of nuclear war.

During biological history four groups of organisms, reptiles, birds, mammals, and insects, have at some time during their evolution developed the power of true flight. Wings evolved but once and early in the evolutionary history of insects, and this ancestral pattern gave rise to the vast majority of present-day forms. Their ability to move rapidly from one area to another gives them a great flexibility and advantage in selecting suitable environments for survival, growth, and reproduction.¹ They also possess a great genetic variability that has permitted them to adapt to almost every conceivable habitat. Most species have

a high reproductive potential and produce several generations per year; this permits them to increase rapidly in numbers during the favorable season.

Eighty-five percent of all insect species have complete metamorphosis, which permits specialization in different phases of their life history. Thus feeding and growth occur during the larval period; differentiation occurs in the pupal period; and mating, migration, and reproduction occur during the adult stage. Mobility, genetic variability, high reproductive potential, and complete metamorphosis have contributed greatly to the biological success of this diverse group of organisms.

As a group insects are highly resistant to radiation, and many species have additional survival potential from fallout radiation because they spend a part of their life cycle protected in the soil, within plant tissue, within the plant debris near the soil surface, etc.

There are about 2 million arthropod species. Many of those in the classes Insecta and Arachnida are phytophagous and compete with man and his domestic animals for food, and others attack man and animals directly or transmit plant and animal diseases. On the other hand, there are tremendous numbers of beneficial species. Some insects are plant pollinators; others aid in the decomposition and recycling of plant and animal debris; and, finally, there are thousands of predators and parasites that attack and destroy the destructive species.² For these and other reasons, both the destructive and the beneficial forms can certainly be considered important factors in the production of food in the event of nuclear disaster.

This does not mean that insects are more important than fungi, bacteria, or viruses attacking plants and animals or that insects are more important than the hundreds of weed species competing with our commercial crops. The successful manipulation and control of all these organisms play important roles in high-quality and -quantity food production.

Crop losses from pests amount to billions of dollars each year, and costs of pest control add an additional burden (Table 1). (The data in the table, which were accumulated from the U. S. Department of Agriculture,³ do not include losses to livestock.)

The data in Table 1 show that during the period from 1951 to 1960 the average cost of pesticides and application for insect control amounted to nearly \$750 million per year. Because of resistance problems and an increasing number of pests, there is every reason to believe that this figure has increased markedly since 1960. Likewise, many herbicides were still in the development stage during 1951 to 1960, and therefore at present herbicides make up much more than 8% of the total of the controls. With the exception of weed control (cultivation, disking, and plowing are still the major means of combatting weeds), agricultural chemicals carry the main burden of crop protection against potentially devastating losses. I calculated agrochemicals to be about 34% of the annual control costs during the period from 1951 to 1960. At the same time, the use of these chemicals adds greatly to disruptions in the agroecosystem.

Table 1
 SUMMARY OF ESTIMATED AVERAGE ANNUAL LOSSES TO AGRICULTURAL
 COMMODITIES FROM VARIOUS HAZARDS AND COST OF CONTROLLING
 THESE LOSSES AND OF INSPECTION AND QUARANTINE PROGRAMS
 (1951-1960)*

Kind of loss and control program	Thousands of dollars		Type of control, %
	Loss in value	Cost of control	
Loss of Crops, Pasture, and Range Plants			
During production			
Diseases of crops and pasture and range plants	3,251,114	115,800	Chemicals, 94 Disease-free plants, 6
Nematode damage	372,335	16,000	Nematocides, 100
Injurious insects	3,812,406	425,000†	Insecticides, 99 Cultural and biological, 1
Weeds in crops, pasture, and range land	2,459,630	2,551,050	Cultural, 92 Herbicides, 8
After production			
During storage (due to insect and other losses)	1,042,063	279,302	Primarily insecticides
Control Programs			
Cooperative plant-pest control programs		24,521	Chemicals and other control measures
Plant quarantine and regulatory programs		4,162	Chemicals and other control measures
Total	10,937,548	3,415,835	Chemicals, 34

*The estimates indicate not only preventable reductions in production but also, in some cases, losses not avoidable with present technical knowledge. For various reasons these must be interpreted as losses to the public rather than to farmers. (See USDA Agricultural Handbook No. 291, Ref. 3.)

†Figures include cost of controlling insects affecting crops, man, animals, and households.

AGROECOSYSTEMS AND NATURAL COMMUNITIES

Agroecosystems as well as natural communities are usually considered to be self-sufficient habitats where the living organisms and the nonliving environment interact in the exchange of matter and energy in a continuing cycle.^{4,5} The natural community can exist without man, but the agroecosystem is manipulated by him and represents his efforts to control nature and to meet his need for food and other products. The degree of man's dominance in agroecosystems varies considerably from one area to another. Moreover, the causes of agroecological-induced arthropod disturbances are multitudinal and can often be correlated with the degree of man's activity in the systems.

An example of a simple agroecosystem with very little manipulation by man can be found on the rocky slopes and along the stream beds on the southwest coast of Turkey. This simple system extends from Izmir 200 to 300 miles south toward Antalya. For centuries a small number of people have lived in this area, surviving along the stream beds on small patches of grain and some vegetables, a few fish from the Aegean Sea, and some sheep and goat products.

Recently the Food and Agriculture Organization of the United Nations supported the planting of thousands of olive trees on the nonproductive brush-covered slopes in 40-to-50-ft spaced natural contours to avoid erosion. In addition to his previous meager food sources, the Turkish peasant now has an olive crop, of sorts, but he does little more to the environment than keep the brush from closing in on the contoured olive-tree plantings.

The original arthropod fauna in this area has changed slightly in response to the increased olive crop. There is now a higher number of olive fruit flies, *Dacus oleae* (Gmelin); olive moths, *Prays oleae*; oleander scales, *Aspidiotus bederae* (Vallot); and black scales, *Saissetia oleae* (Bernard). But these changes have been minor.

At the other extreme is the once barren Imperial Valley in southern California, carved out of an ancient seabed and made into one of the most highly productive agroecosystems on earth. This valley receives about 1 to 3 in. of rainfall per year and is entirely dependent on irrigation water from the Colorado River 50 to 60 miles away. Agricultural production consists of a wide variety of fall, winter, and spring vegetables, citrus fruits, forage crops, vegetable seed crops, sugar beets, cotton, small grains, melons, beef cattle, etc. Only a minute fraction of the raw or processed products is consumed or used by the small number of inhabitants of the valley.

Throughout the year irrigation water, fertilizers, insecticides, herbicides, fungicides, and nematocides are added to the environment as various fields are plowed, special crops are planted and harvested, and the plant debris is plowed under in preparation for the next crop. With the exception of high solar energy input nearly 365 days per year and the parent soil, this agroecosystem is entirely artificial and totally dependent on manipulation by man for its existence.

Sixty years ago this valley was essentially uninhabited by man. There were a few insects present which were pests elsewhere, but they were of no concern in this valley since they did not compete with man for existence. Because of the present abundance of food and the very high temperatures in summer and moderate temperatures in winter, this valley is a perfect insectary. It now supports a large number of insect- and mite-pest species; in addition to the original potential pests, a large number of others have come from outside sources. Owing to a high input of pesticides with wide toxicity spectrum and to the continuous planting and plowing of short-lived annual crops, pest populations are often present in damaging or potentially damaging abundance throughout the year in contrast to arthropods in natural communities.

Although the Imperial Valley is superficially different from agroecosystems in the midwestern, southern, and eastern United States, the causes of imbalance and eruption of pest species are similar in all agroecosystems. From one extreme to the other, the different types and structures of agroecosystems represent a type of stability because of the general continuity of man's special food plants grown under the prevailing climate as well as varying degrees of disturbance.

By contrast, in natural communities where a wide variety of plant and animal species are meshed in complex food chains, it is uncommon that plants are massively destroyed by phytophagous insects. There are of course special cases where destruction occurs periodically, for example, the attacks on balsam fir in eastern Canada⁶ by the spruce budworm, *Choristoneura fumiferana* (Clemens); the attacks on lodgepole pine in California and elsewhere⁷ by the lodgepole needle miner, *Coleotechnites milleri* (Busck); and the historical cases of plagues of grasshoppers and locusts in parts of Africa and Asia.⁸

The reasons for more-balanced population regulation in natural communities are generally believed to be the high degree of diversity, continuity, and stability in natural plant-animal communities as compared with simplified agroecosystems.^{9,10} However, it is still debatable how these three factors interact to hold populations in check so that a single or a few species rarely cause disruption in these evolutionary-oriented ecological systems. In other words, in natural communities a very strict police state exists and appears to be regulated by the organisms themselves to preserve an orderly population abundance system.

In the evolution of all species at various trophic levels and in the complex interrelations of eating and being eaten, varying degrees of governing mechanisms have evolved to hold species populations in check.* Governing mechanisms that help to determine population levels within the framework or the potential set by other environmental elements include not only immediate or direct factors producing premature mortality, retarded development, or reduced fecundity¹¹ but also all aspects of the environment.

In contrast to this orderly system, in the agroecosystem man operates and controls the plant life and is often the main disrupting force.

MAN AND HIS ARTHROPOD COMPETITORS

In the past several centuries, man has developed a technology that permits him to greatly modify environments to meet his need for food and space. Modifying the environment for the competition between man and other organisms would appear to favor man, as is attested by the decimation of vast vertebrate populations, as well as populations of other forms of life.¹² But when man eliminated many species as he changed the natural communities into

*Some definitions and explanations of terms are given in the appendix (pages 451-452) to clarify certain parts of this paper.

agroecosystems, a number of other species, particularly the arthropods, became his direct competitors.¹³ Thus, when early man subsisted in undisturbed natural communities as a huntsman or foraged for food from uncultivated sources, he was rarely confronted with exploding insect populations, except for sporadic eruptions of plagues of grasshoppers and locusts.

Today, by contrast, as man's population continues to increase and his food-production activities are intensified, he is now in direct competition with thousands of phytophagous arthropod species.¹⁴

The increase in population numbers of a particular species to pest status may be the result of a single factor or a combination of factors.

First, by changing or manipulating the environment, we can create conditions that permit certain species to increase their population density.¹⁵ The rise of the Colorado potato beetle, *Leptinotarsa decemlineata* (Say), from an unimportant species to one of major importance occurred in this manner (Fig. 1). Before 1850 this beetle existed in very low numbers feeding on sand burr, *Solanum rostratum* Dunal, and other plants along the eastern slopes of the Rocky Mountains. When the American pioneers moved westward, they planted

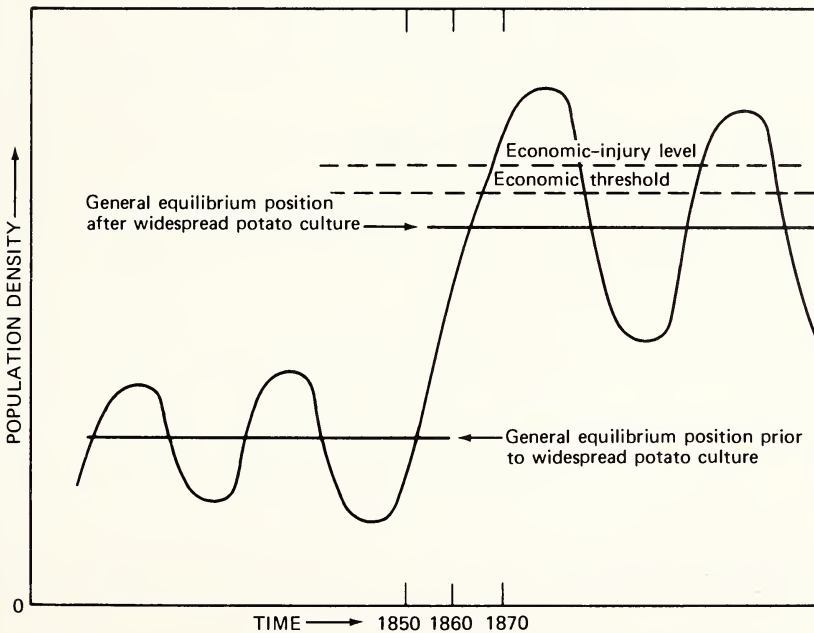

Fig. 1 Change in general equilibrium position of the Colorado potato beetle, *Leptinotarsa decemlineata*, after development of widespread potato culture in the United States. (For a discussion of the significance of economic-injury levels and economic thresholds in relation to the general equilibrium position, see section on the severity of pests and the definitions in the appendix.)

the potato widely as one of their main food sources. Widespread cultivation of the potato was a change in the environment which was favorable to the beetle, and this enabled it to quickly become an important pest. Not only the increase of a new food source but also the plowing of the prairie and the destruction of forested regions aided in the expansion of its range of distribution. In a few years it was a pest in all of eastern North America. This beetle was unknowingly transported to Europe after World War I and is now a major pest in that region also.

Similarly, when alfalfa, *Medicago sativa* L., was introduced into California about 1850, the alfalfa butterfly, *Colias eurytheme* Boisduval, which had previously occurred in low numbers on native legumes, found a widespread and favorable new host plant in its environment and subsequently became an economic pest.¹⁶

A second way in which arthropods have risen to pest status is by being transported across geographical barriers and leaving behind their specific predators, parasites, and diseases.¹⁷ For example, the cottony-cushion scale, *Icerya purchasi* Maskell (Fig. 2), was introduced into California from Australia on ornamental acacia plants in 1868. Within two decades it increased in abundance to the point where it threatened economic disaster to the entire

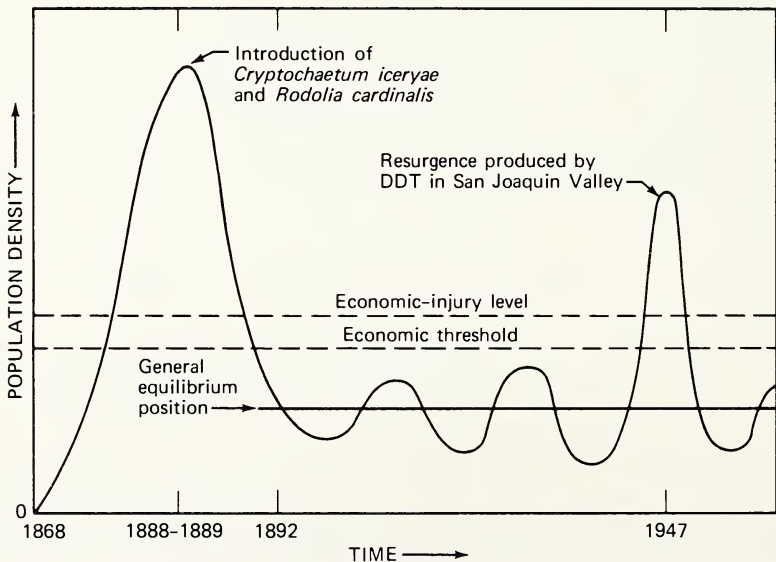

Fig. 2 Fluctuations in population density of the cottony-cushion scale, *Icerya purchasi*, on citrus from the time of its introduction into California in 1868. After the successful introduction of two of its natural enemies in 1888, this scale was reduced to noneconomic status except for a local resurgence produced by DDT treatments about 1947.

citrus industry in California. Fortunately the timely importation and establishment of two of its natural enemies [the vedalia, *Rodolia cardinalis* (Mulsant) and *Cryptochaetum iceryae* (Williston)] from Australia resulted in the complete suppression of *I. purchasi* as a citrus pest.¹⁸ The cottony-cushion scale again rose to major pest status in 1947 when the widespread use of DDT eliminated the vedalia on citrus in the San Joaquin Valley.¹⁹

A third cause for the increasing number of pest arthropods has been the establishment of progressively lower economic thresholds. This can be illustrated by lygus bugs, *Lygus* species, on lima beans. Not many years ago the blotches caused by lygus bugs feeding on an occasional lima bean were of little concern, and the bugs were considered a minor pest on this crop. With the emphasis on product appearance in the frozen-food industry, however, a demand was created for a near-perfect bean. For this reason very low economic-injury thresholds were established, and lygus bugs are now considered serious pests on lima beans.

In addition to food-product appearance, which is often related to competitive marketing, certain marketing standards dictate a minimum degree of damage or insect parts permissible in or on raw or processed products.²⁰ At present these standards often impose severe requirements for chemical pest control. In a situation of critical food shortage following nuclear disaster, insects that affect commodity appearance or the presence of a few insect parts in or on food would undoubtedly be ignored. This in turn would help to alleviate any shortage of insecticides, and the chemicals available could be used in situations where entire crops are threatened.

A fourth way by which insects can rise to pest status is by the elimination of biological control agents that hold a potential pest in check.²¹ Recent examples include the outbreak of the beet armyworm, *Spodoptera exigua* (Hubner); the cabbage looper, *Trichoplusia ni* (Hubner); and bollworm, *Heliothis zea* (Boddie), following treatments with Azodrin, Bidrin, and other chemicals to control lygus bugs in cotton fields in the San Joaquin Valley.* The outbreak of the cotton leaf perforator, *Bucculatrix thurberiella* Busck, the beet armyworm, and the cabbage looper following widespread chemical treatments for control of the pink bollworm, *Pectinophora gossypiella* (Saunders), in the Imperial Valley are others among many examples.

The increased pest severity due to elimination of beneficial species by pesticides is of special interest in relation to radioactive fallout. At present, other than studies of radiation effects on honeybees and a few insect predators and parasites, there are few or no data to indicate whether radiation might act differentially on the entomophagous species (i.e., those feeding on other arthropods) in comparison with the phytophagous species. More research is needed in this area, particularly in the insect orders Hemiptera (sucking bugs), Coleoptera (beetles), Hymenoptera (bees, ants, and wasps), and Diptera (flies

*R. van den Bosch, University of California, unpublished data.

and mosquitoes), which contain large numbers of beneficial species in addition to pest species. As matters now stand, nearly all the research on effects of radiation on arthropods has been conducted on pest species in relation to the male-sterilization technique for pest control.^{2,2,3}

SEVERITY OF VARIOUS PEST SPECIES

To determine the relative economic importance of pest species, we must consider both the economic threshold and the general equilibrium position of the pest. The general equilibrium position and its relation to the economic threshold, in conjunction with the frequency and amplitude of fluctuations about the general equilibrium position, determine the severity of a particular pest problem.

In the absence of permanent modification in the environment, the density of a species tends to fluctuate about the general equilibrium position as changes occur in the biotic and physical components of the environment. As the population density increases, the density-governing factors respond with greater and greater intensity to check the increase; as the population density decreases, these factors relax in their effects. The general equilibrium position is thus determined by the interaction of the species population, the density-governing factors, and the other natural factors of the environment. A permanent alteration of any factor of the environment, either physical or biotic, or the introduction of new factors may alter the general equilibrium position.^{1,3}

The economic threshold of a pest species can be at the level of or at any level above or below the general equilibrium position. Some phytophagous species utilize our crops as a food source but even at their highest attainable density are of little or no significance to man (Fig. 3). Such species can be found associated with nearly every crop of commercial concern.

Another group of arthropods rarely exceeds the economic threshold and consequently are occasional pests. Only at their highest population density will chemical control be necessary (Fig. 4).

When the general equilibrium position is close to the economic threshold, the population density will frequently reach this threshold (Fig. 5). In some cases the general equilibrium position and the economic threshold are at essentially the same level. Thus insecticidal treatment is necessary each time the population fluctuates up to the level of the general equilibrium position. In such species the frequency of chemical treatments is determined by the fluctuation rate about the general equilibrium position, which in some cases necessitates almost continuous treatment.^{1,3}

Finally, for some pest species the economic threshold lies below the general equilibrium position. These constitute the most severe pest problems in entomology (Fig. 6). The economic threshold may be lower than the level of the lowest population depression caused by the physical and biotic factors of the

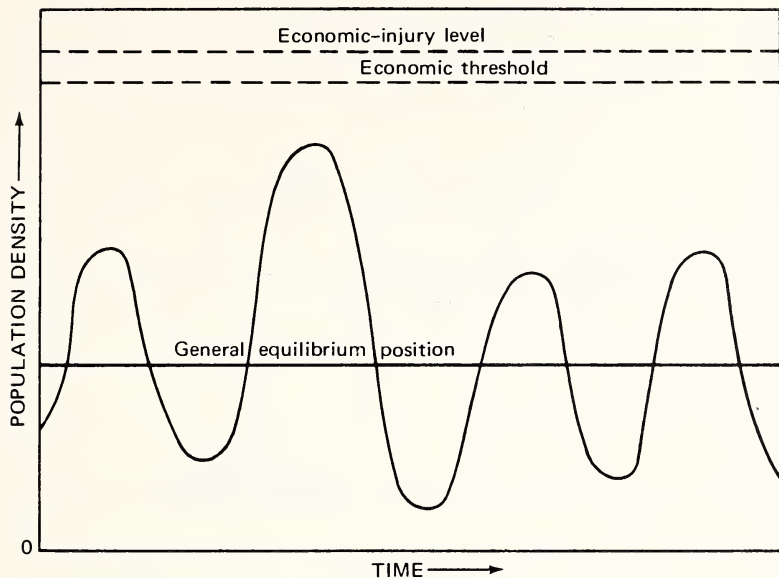

Fig. 3 Noneconomic population whose general equilibrium position and highest fluctuations are below the economic threshold, e.g., *Aphis medicaginis* Koch on alfalfa in California.

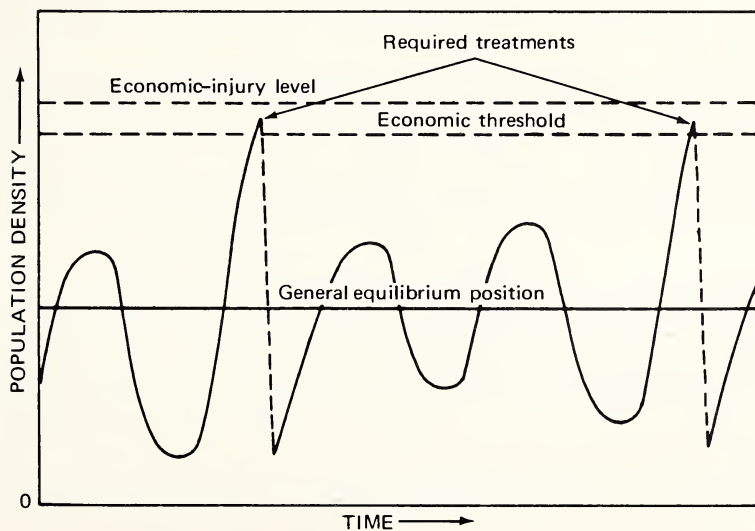

Fig. 4 Occasional pest whose general equilibrium position is below the economic threshold but whose highest population fluctuations exceed the economic threshold, e.g., *Grapholitha molesta* Busck on peaches in California.

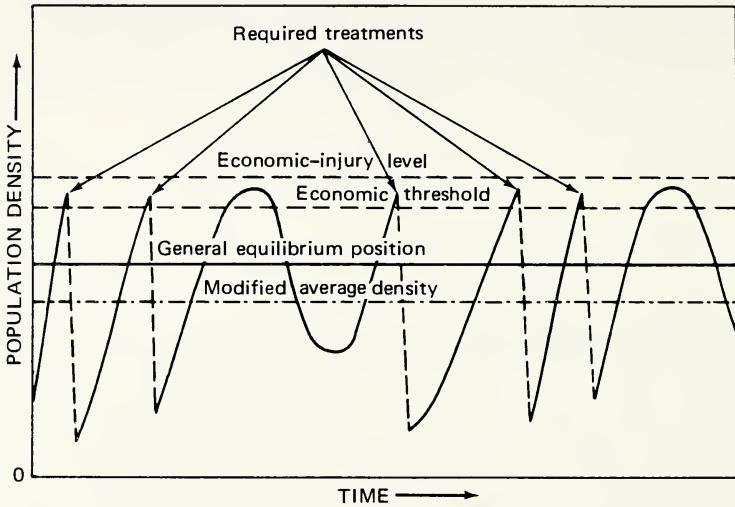

Fig. 5 Perennial pest whose general equilibrium position is below the economic threshold but whose population fluctuations frequently exceed the economic threshold, e.g., *Lygus* species on alfalfa seed in the western United States.

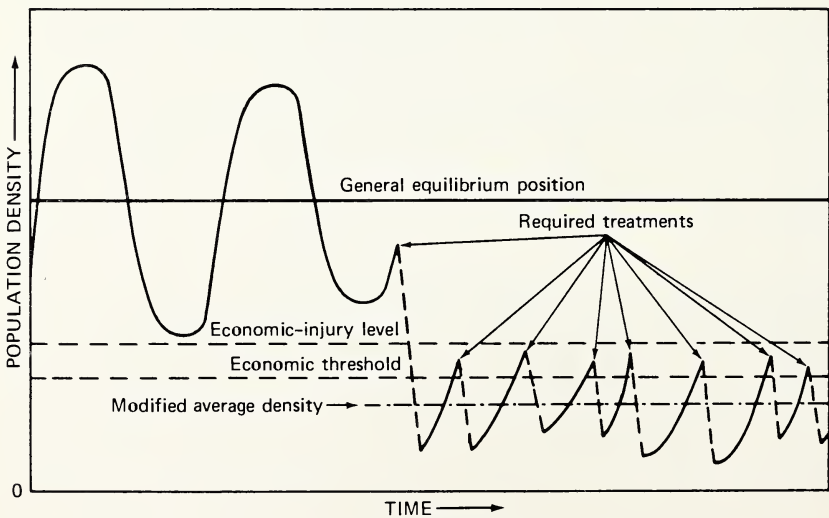

Fig. 6 Severe pest whose general equilibrium position is above the economic threshold and for which frequent and often widespread use of insecticides is required to prevent economic damage, e.g., *Musca domestica* in Grade A milking sheds.

environment, e.g., many insect vectors of viruses. In such cases, particularly where human health is concerned, there is a widespread and almost constant need for chemical control. This produces conditions favorable for development of insecticide resistance and other problems associated with heavy treatments.

DISPERSION OF PEST SPECIES

A species population is flexible and undergoes constant change within the limits imposed upon it by its genetic constitution and the characteristics of its environment. Typical fluctuations in population density and dispersion are shown in Fig. 7. The population dispersions shown at the three points in time,

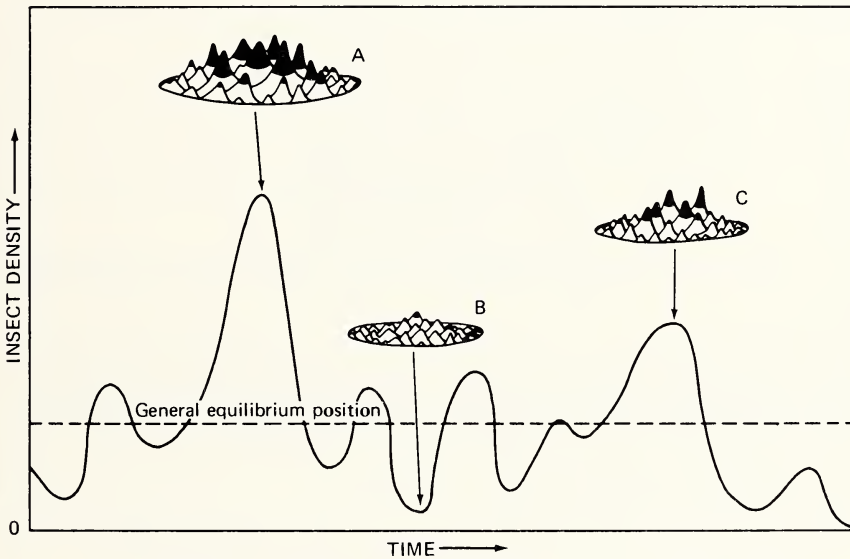

Fig. 7 Population trend and population dispersion of a pest species over a long period of time. —, fluctuations in the population density with time; ---, general equilibrium position. A, B, and C, population dispersion at specific times. The basal area of models A, B, and C reflects the distributional range, and the height indicates population density. Population densities above the economic threshold are blacked.

A, B, and C, are not static but rather are instantaneous phases of a continuously changing dispersion.¹³

Thus at point A, when the population is of greatest numerical abundance, it also has its widest distributional range (as depicted by the maximum diameter of the base of the model) and is of maximum economic status (as depicted by the number and magnitude of the blackened pinnacles representing penetrations of

the economic threshold). At point B, on the other hand, when the species population is at its lowest numerical abundance, it is generally most restricted in geographical range and is of only minor economic status. Point C represents an intermediate condition between points A and B.

Figure 8, which is related to Fig. 7, illustrates the relation between the geographic distribution of a species and the interrelatedness of physical and

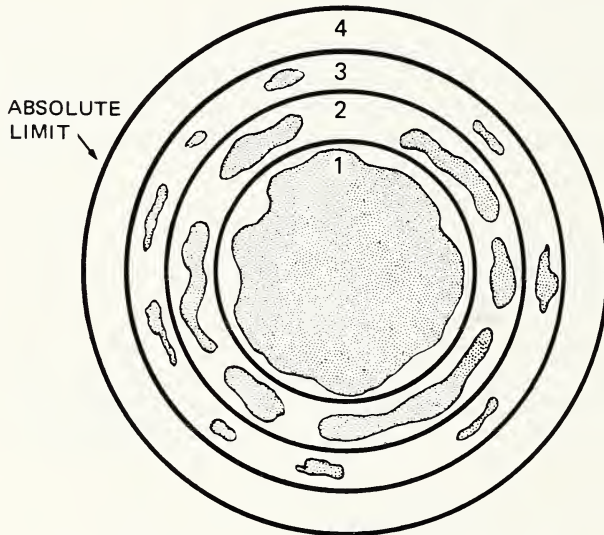

- Zone 1 Stable zone of permanent occupancy; most nearly optimal physical conditions.
- Zone 2 Intermediate zone of permanent occupancy; physical conditions intermediate.
- Zone 3 Marginal zone of permanent occupancy; physical conditions rigorous, mostly unfavorable; at very limited places permanently permissive.
- Zone 4 Zone of only temporary occupancy; physical conditions only temporarily permissive anywhere; dependent on immigration.

Fig. 8 Geographic distribution of a species population and the interrelation of conditioning and regulating forces. Physical factors are never permissive for occupancy beyond zone 4. (Data from C. B. Huffaker and P. Messenger, *The Concept and Significance of Natural Control*, in *Biological Control of Insect Pests and Weeds*, P. DeBach (Ed.), Chap. 4, Reinhold Publishing Company, New York, 1964.)

biotic factors in the environment. Each circle (zone) of the concentric series represents a type of environment. The irregular patches in each zone represent localized areas of relative permanent favorability in regard to physical conditions, and the interspaces represent the degree of waxing and waning of such areas in time.

The relative sizes of these zones as shown here have no significance. One species, such as the corn earworm, *H. zea*, may range over thousands of square miles; another species may be restricted to one or two states or even less.

The environment of zone 1 has nearly optimal climatic conditions, at least during a certain part of the year, and permits an increase in numbers generation after generation. In the environment of zone 4, at the other extreme, only temporary existence is possible. If any part of the species population is eliminated in part of its range by pesticides, radioactive fallout, use of sterile males, unfavorable heat or cold, elimination of food, etc., the survivors in the adjoining areas will repopulate the disturbed area once the unfavorable factor has disappeared. The rate of reinvasion will depend on prevailing physical factors and on the flight habits, behavior, and ecology of the species involved.

In the environment of zone 1, essentially the total area is represented by maximum favorability in the physical framework of the environment; hence there is little room for changing physical conditions to alter population potential.

In the environment of zone 3, on the other hand, permanently favorable localized habitats are greatly reduced. Thus the waxing and waning of population potentials is a dominant feature relative to climatic factors causing population change. However, the role of physical forces and natural enemies is still the same as in the environments of zones 1 and 2. In the environment of zone 4, migrants from the more favorable areas are necessary to populate the area when favorability is temporarily permitted.

THE MONOCULTURE AND ITS INHERENT ARTHROPOD PROBLEMS

Earlier in this discussion arthropod populations in a very simple agroecosystem with little interference from man (the southwest coast of Turkey) and in a highly intensified system with great interference from man (the Imperial Valley) were contrasted to arthropod populations in natural communities. Another type of agroecosystem that is quite similar to the Imperial Valley but differs in plant and animal composition is the monoculture developed in parts of the Midwest and in sections of the western United States. In these systems the tendency of pest populations to appear in damaging numbers year after year is almost an accepted fact.

A good example of a monoculture occurs on the west side of the San Joaquin Valley. This particular portion of the valley is 30 to 40 miles wide and about 150 miles long. Farming operations are very large in comparison with other parts of the United States. The individually owned and corporate farms range from very small operations of 3 to 4 square miles of irrigated farm land upward to nearly 175 square miles of highly intensified irrigated agriculture.

The only trees and shrubs in this area are those planted around a few widely scattered ranch headquarters. The commercial plants, literally the only plants permitted to grow in this area, are pure stands of cotton, safflower, cantalopes, alfalfa as a seed crop, barley, tomatoes, and sugar beets. Rarely is a crop planted in a field smaller than 160 acres. All other plants are destroyed by a preplant

herbicide or by cultivation. Weeds germinating along the edges of fields and roads after the winter rains are disked under in early spring after the rains cease, or they are destroyed by desiccating oils.

Increasing to damaging numbers each year are tremendous populations of lygus bugs, *Lygus hesperus* Knight and *L. elisus* Van Duzee; cabbage loopers, *T. ni*; beet armyworms, *S. exigua*; bollworms, *H. zea*; spider mites, *Tetranychus* species; spotted alfalfa aphid, *Therioaphis trifolii* (Monell); and other insects.

Lygus bugs increase to high numbers in the winter safflower crop and in the alfalfa seed crop.²⁴ When the safflower begins to dry in late spring, the lygus bugs fly to cotton, and chemical treatments begin. Nearly all the lepidopterous pests increase to high numbers following the early chemical treatments for lygus bugs, which destroy the predators and parasites of these pests.* These worm species come from outside sources, survive because of resistance to the chemical, or are protected in the soil and elsewhere at the time of treatment. With the elimination of their predators and parasites, these pests are free to increase unhindered.

Treatments with some chemicals, such as Azodrin or Bidrin, are more drastic in their ecological effects than treatments with Dylox. In fact, the disruptive effects of Azodrin on birdlife and the resurgence of secondary insect-pest species following treatment are very noticeable; thus this chemical cannot be used in California after July 15 each year. Theoretically this should permit a time interval for the predators and parasites to reenter the treated fields and become reestablished. However, our preliminary data indicate that, once the arthropod food chain is destroyed, the insect usually does not become reestablished for the remainder of the season.

If pest control could be considered as a single factor, work toward the development of complex polycultures as opposed to the monoculture type of agriculture would be highly desirable. The interplanting of various species and varieties of crops in complex polycultures may result in yields of total biomass equal to or greater than those produced in monocultures. However, pest control is only one aspect of food production. It remains to be seen whether American farming systems can be devised which are of satisfactory efficiency in carrying out all the agronomic practices in such a complex mixture of crops. Converting monocultural systems back to mixed agriculture demands further economic study since much of the success of the American farmer stems from research and development leading to simplifying the agroecosystem. Likewise, the physical factors of soil and climate often predetermine special types of crops most economically productive for a given area. Furthermore, the era of the family-type diversified farm is past, and farmers on a regional basis find it most profitable to concentrate on a few specialized crops best suited for that area.

*V. M. Stern and R. van den Bosch, University of California, Riverside, unpublished data.

This is quite noticeable when we survey the acreages of rice, corn, potatoes, vegetables, peas, beans, sugar beets, sugarcane, soybeans, vineyards, and orchards as they are distributed in the United States.^{2,5}

SIMILARITY OF PESTICIDES AND FALLOUT RADIATION

With the exception of field tests of relatively small size and laboratory radiation studies on 100 to 200 insect and mite species selected from the 2 million arthropod species, there is little information concerning the effects that fallout may have on arthropod populations over wide areas.^{2,2} However, some comparisons might be made between the ecologically disruptive effects of the use of widely toxic pesticides and radioactive fallout. This comparison requires some information concerning the development and nature of commercial pesticides.

One reason for ecological disruption arising from modern pesticides stems from the manner in which these compounds are developed commercially. During development and in registering, essentially no ecological considerations enter into the search for new compounds. The candidate materials are screened on the basis of maximum kill on 8 to 12 laboratory cultures of pest species and for phytotoxicity. The basic considerations as to whether a particular compound will be developed are: (1) the size of the potential market for the compound, (2) competing products in that market and the company's patent control over the new product and its competitors, (3) the possibilities of recouping development costs and returning a profit, and (4) certain safety factors with respect to residues, application, and human health.

Under this system the ideal material from the commercial viewpoint is one that can be registered and labeled for use against a very broad spectrum of pests on a wide variety of crops.

It is precisely this type of compound with a broad toxicity spectrum which kills not only pest species but also beneficial insects (plant pollinators, predators, and parasites). As a result, a large proportion of these compounds are ecologically disruptive.^{4,5,13}

When pesticides are used for control, they involve only immediate and temporary reduction of populations and do not contribute to permanent pest-density regulation. Theoretically they are employed to reduce pest species that rise to dangerous levels when natural enemies of the pest and other environmental pressures are inadequate.

On some occasions the pest outbreak and the application of a pesticide for its control may cover a wide area, e.g., the outbreak of the spruce budworm, *C. fumiferana*, in northeastern Canada⁶ or of lygus bugs, *L. hesperus* and *L. elisus*, in the San Joaquin Valley.^{2,4} In other instances damaging numbers of pests may occur in restricted locations. In either case these outbreaks occur during the season favorable to the pest, with the relaxed environmental pressures occurring

sometime before the outbreak. As mentioned previously, in our agroecosystems we often simplify and change the environment to such a degree that the environmental pressures holding pests in check are totally inadequate.

Since most pest species have wide ranges of distribution (often hundreds of miles and from one state to another), the treated area is always subjected to reinvasion from individuals outside the area or by rapid resurgence from those not destroyed within the treated area.²²

In some ways, other than genetic changes induced by radiation and phytotoxicity, radioactive fallout can be similar to insecticides. It is well known that some insecticides do exhibit differential killing effects on various species when applied at commercial dosages. Of course, 20 lb of actual Azodrin per acre will probably eliminate all the exposed arthropods, and probably the plants as well; so will radiation doses of 100 kR. However, LaChance²³ in discussing insect sterility data, points out that radiation also has differential effects on arthropods. Most Dipteran species can be sterilized with doses under 10 kR, but within this order a threefold difference was noted. The Hymenoptera require about 6 to 10 kR, and most Coleoptera seem to sterilize at 4 to 10 kR. On the other hand, the Lepidoptera, essentially all species of which are phytophagous and which includes some of the most ravaging species on earth, requires very large doses to produce sterility. Thus radiation can be similar to insecticides as far as its differential effects on insects are concerned. In both cases the reasons for these differential effects is not entirely clear. In regard to radiation, more research on interphase nuclear volumes or nuclear DNA content may be required before comparisons are meaningful.²³

The data of Miller²⁶ and Callahan et al.²⁷ indicate that after a nuclear disaster there will be areas with sufficiently low radiation fields to permit survival of many pest arthropods because as a group these insects are quite tolerant to radiation and most pest species have wide ranges of distribution. The pest species can be expected to reinvade the disturbed area as soon as the effects of radiation are low enough for plants to become established. The mobility of insect-pest species attacking our major food crops and their reinvasion time after elimination from wide areas were reported previously.²²

For the reasons mentioned, radioactive fallout would appear to act similarly to an insecticide in its disruptive effects on arthropods. Pesticides are usually added to a restricted segment of the environment to eliminate a localized population. Because insecticides and radioactive fallout are nonreproductive, have no searching capacity, and are more or less nonpersistent (as far as continuous killing effects are concerned), they constitute short-term, restricted pressures. These types of materials cannot permanently change the general equilibrium position of the pest population, nor can they restrain an increase in abundance of the pest without repeated applications. Therefore to destroy pests they must be added to the environment at varying intervals of time.

After a chemical application the pest population density may be far below the economic threshold and below its general equilibrium position, but, since the

insecticide is not a permanent part of the environment, the pest usually returns to a high level when the effects of the insecticide are gone.

These killing measures have little influence on the pest in adjoining areas except as localized population depressants.

In the highest-radiation field, certain insect species would undoubtedly be nearly completely eliminated. Away from the high-radiation field, there would be less mortality and various types of genetic change. Whether the offspring of these individuals could survive and compete in nature is unknown.

However, individuals from low-radiation areas would be invading the disturbed area even before the radiation had disappeared. By continuous reinvasion individuals would eventually become established as soon as plant species were available for food. For these and the reasons mentioned earlier, pest insects and their control can be expected to be important considerations in food production in the event of nuclear disaster.

APPENDIX: DEFINITION OF TERMS

Biological control. The action of parasites, predators, or pathogens on a host or prey population which produces a lower general equilibrium position than would prevail in the absence of these agents. Biological control is a part of natural control, and in many cases it may be the key mechanism governing the population levels within the framework set by the environment. If the host or prey population is a pest species, biological control may or may not result in economic control.

Economic control. The reduction or maintenance of a pest density below the economic-injury level.

Economic-injury level. The lowest population density that will cause economic damage. Economic damage is the amount of injury which will justify the cost of artificial control measures; consequently the economic-injury level may vary from area to area, from season to season, or with man's changing scale of economic values.

Economic threshold. The density at which control measures should be determined to prevent an increasing pest population from reaching the economic-injury level. The economic threshold is lower than the economic-injury level to permit sufficient time for initiation of control measures and for these measures to take effect before the economic-injury level is reached.

General equilibrium position. The average density of a population over a period of time (usually lengthy) in the absence of permanent environmental change. The size of the area involved and the length of the period of time will vary with the species under consideration. Temporary artificial modifications of the environment may produce a temporary alteration of the general equilibrium position (i.e., a temporary equilibrium).

Governing mechanism. The actions of environmental factors, collectively or singly, which intensify as the population density increases and relax as this density falls so that population increase beyond a characteristic high level is prevented and decrease to extinction is made unlikely. The governing mechanisms operate within the framework or potential set by the other environmental elements.

Natural control. The maintenance of a more or less fluctuating population density within certain definable upper and lower limits over a period of time by the combined actions of abiotic and biotic elements of the environment. Natural control involves all aspects of the environment, not just those immediate or direct factors producing premature mortality, retarded development, or reduced fecundity but remote or indirect factors as well. For most situations, governing mechanisms are present and determine the population levels within the framework or potential set by the other environmental elements. Natural control of a pest population may or may not be sufficient to provide economic control.

Population. A group of individuals of the same species that occupies a given area. A population must have at least a minimum size and occupy an area containing all its ecological requisites to display fully such characteristics as growth, dispersion, fluctuation, turnover, dispersal, genetic variability, and continuity in time. The minimum population and the requisites in an occupied area will vary from species to species.

Population dispersion. The pattern of spacing shown by members of a population within an occupied habitat and the total area over which the given population may be spread.

Temporary equilibrium position. The average density of a population over a large area temporarily modified by a procedure such as continued use of insecticides. The modified average density of the population will revert to the previous or normal density level when the modifying agent is removed or expended. (Cf. General equilibrium position.)

REFERENCES

1. R. D. O'Brien and L. S. Wolfe, *Radiation, Radioactivity, and Insects*, Academic Press, Inc., New York, 1964.
2. P. DeBach (Ed.), *Biological Control of Insect Pests and Weeds*, Reinhold Publishing Corporation, New York, 1964.
3. U. S. Department of Agriculture, *Losses in Agriculture*, Agriculture Handbook No. 291, Superintendent of Documents, U. S. Government Printing Office, Washington, D. C., August 1965.
4. R. F. Smith and R. van den Bosch, Integrated Control, in *Pest Control*, W. W. Kilgore and R. L. Doutt (Eds.), Chap. 9, Academic Press, Inc., New York, 1967.
5. R. van den Bosch and V. M. Stern, The Integration of Chemical and Biological Control of Arthropod Pests, *Ann. Rev. Entomol.*, 7: 367-386 (1962).

6. R. F. Morris (Ed.), The Dynamics of Epidemic Spruce Budworm Populations, *Mem. Entomol. Soc. Can.*, No. 31, 1963.
7. A. D. Telford, Features of the Lodgepole Needle Miner Parasite Complex in California, *Can. Entomol.*, 93(5): 394-402 (1961).
8. O. B. Lean, *FAO's Contribution to the Evaluation of International Control of the Desert Locust, 1951-1963*, Food and Agriculture Organization of the United Nations, Rome, 1965.
9. C. B. Huffaker, Summary of a Pest Management Conference—a Critique, in *Concepts of Pest Management*, R. L. Rabb and F. E. Guthrie (Eds.), pp. 227-242, University of North Carolina Press, Chapel Hill, 1970.
10. R. L. Doutt, Biological Control, in *Pest Control*, W. W. Kilgore and R. L. Doutt (Eds.), Chap. 1, Academic Press, Inc., New York, 1967.
11. C. B. Huffaker and P. Messenger, The Concept and Significance of Natural Control, in *Biological Control of Insect Pests and Weeds*, P. DeBach (Ed.), Chap. 4, Reinhold Publishing Company, New York, 1964.
12. W. L. Thomas, Jr. (Ed.), *Man's Role in Changing the Face of the Earth*, The University of Chicago Press, Chicago, 1956.
13. V. M. Stern, R. F. Smith, R. van den Bosch, and K. S. Hagen, The Integration of Chemical and Biological Control of the Spotted Alfalfa Aphid. The Integrated Control Concept, *Hilgardia*, 29(2): 81-101 (1959).
14. C. W. Sabrasky, How Many Insects Are There? *Insects*, Yearbook of Agriculture, pp. 1-7, U. S. Department of Agriculture, Washington, D. C., 1952.
15. G. C. Ulyett, Mortality Factors in Populations of *Plutella maculipennis* (Tineidae: Lep.) and Their Relation to the Problem of Control, *South African Dept. Agr. and Forestry Ent. Mem.*, 2(6): 77-202 (1947).
16. R. F. Smith and W. W. Allen, Insect Control and the Balance of Nature, *Sci. Amer.*, 190(6): 38-42 (1954).
17. R. F. Smith, The Spread of the Spotted Alfalfa Aphid, *Therioaphis maculata* (Buchton), in California, *Hilgardia*, 28(21): 647-691 (1959).
18. R. L. Doutt, Vice, Virtue and the Vedula, *Ent. Soc. Amer., Bull.*, 4(4): 119-123 (1958).
19. W. H. Ewart and P. DeBach, DDT for Control of Citrus Thrips and Citricola Scale, *Calif. Citrograph*, 32: 242-245 (1947).
20. California State Department of Agriculture, Agriculture Code, Standardization Provisions of Administrative Code and Standardization Procedures, Sacramento, 1964.
21. R. van den Bosch and V. M. Stern, The Integration of Chemical and Biological Control of Arthropod Pests, *Ann. Rev. Entomol.*, 7: 367-386 (1962).
22. V. M. Stern, Insect Pests of Major Food Crops, Their Reinvasion Potential and the Effects of Radiation on Arthropods, OCD Work Unit No. 3145B, University of California, 1969.
23. L. E. LaChance, C. H. Schmidt, and R. C. Bushland, Radiation-Induced Sterilization, in *Pest Control*, W. W. Kilgore and R. L. Doutt (Eds.), Chap. 4, Academic Press, Inc., New York, 1967.
24. V. M. Stern et al., Lygus Control by Strip Cutting Alfalfa, Report AXT-241, University of California, Agricultural Extension Service, 1967.
25. U. S. Department of Commerce, *Bureau of the Census for the 1959 Census of Agriculture*, Superintendent of Documents, U. S. Government Printing Office, Washington, D. C., 1965.
26. C. F. Miller, Fallout and Radiological Countermeasures. Vols. 1 and 2, SRI Project No. 1M-4021, Stanford Research Institute, 1963.
27. E. D. Callahan et al., The Probable Fallout Threat Over the Continental United States, Report No. TO-B60-13, Technical Operations Inc., 1960.

ECOLOGICAL EFFECTS OF ACUTE BETA IRRADIATION FROM SIMULATED- FALLOUT PARTICLES ON A NATURAL PLANT COMMUNITY

PETER G. MURPHY* and J. FRANK McCORMICK

Department of Botany, University of North Carolina, Chapel Hill, North Carolina

ABSTRACT

Simulated-fallout particles overcoated with ^{90}Y were applied at two levels of activity to granite-outcrop plant communities. The experiment resembled conditions expected at a site 170 miles downwind of a 2.5-Mt detonation with a wind velocity of 15 mph. Mean community dose levels were 7000 and 4000 rads. In the 7000-rad communities, the ratio of mean ground-surface dose (8770 rads) to mean canopy dose (5092 rads) was 1.7. In the 4000-rad communities, the mean ground-surface dose (4824 rads) was 1.6 times higher than the mean canopy dose (2996 rads).

In the 7000-rad communities, the death of 46% of all terminal buds in the dominant *Viguiera porteri* resulted in a 37% height-growth reduction, a compensatory lateral branch development, a 16% reduction in community biomass, and a lower, more clumped, vertical distribution of leaves in the canopy. Comparison with earlier studies indicated that acute beta irradiation may be twice as effective as chronic gamma irradiation at equivalent total doses in causing height-growth reduction in *V. porteri*.

No radiation-induced change in the metabolism of the outcrop ecosystem was detected through measurements of CO_2 exchange 43 days after fallout dispersal. The mean rate of net production on clear days in both July and September (9:30 a.m. to 4:40 p.m.) was $1.2 \text{ g C/m}^2/\text{hr}$. Early nighttime rates of respiration (9:30 to 10:10 p.m.) averaged $2.9 \text{ g C/m}^2/\text{hr}$ in July and $2.2 \text{ g C/m}^2/\text{hr}$ in September.

Only since 1959 have the effects of ionizing radiation on entire plant communities and ecosystems been experimentally investigated. McCormick's study of a granite-outcrop plant community¹ and Woodwell's study of a Long Island forest² were among the first investigations of radiation effects in natural plant communities. A common finding of these and subsequent studies has been that ecosystems respond to radiation stress much as they do to other

*Present address: Department of Botany and Plant Pathology, Michigan State University, East Lansing, Mich.

environmental stresses. An overall setback in successional status is a basic pattern observed. Ionizing radiation therefore becomes of interest as a tool for studying mechanisms of adjustment, or homeostasis, in ecosystems.

Platt³ pointed out that ionizing radiation is an environmental stress on organisms and ecosystems and as such must be considered as another environmental factor. In an interesting discussion Odum⁴ explained that many of the consequences of ionizing radiation in ecosystems are not unique and can result from a variety of nonnuclear forces in the biosphere. Woodwell⁵ discussed ionizing radiation and fallout as model pollutants and in a subsequent article⁶ pointed out similarities between radiation effects and the effects of fire, oxides of sulfur, and herbicides. It is apparent that studies of the interaction of ionizing radiation with biological systems are of ecological interest not only for the information they supply on specific radiation effects but also for their contribution toward an understanding of the relation between structure and function in ecosystems.

In studies of the effects of radiation on vegetation, the tendency has been to consider only gamma radiation of importance if the dose is from sources external to the vegetation and beta radiation of significance only as an internal factor. Until recently it was generally assumed that the limited penetrating ability of external beta radiation would prevent its causing serious damage to vegetation. Rhoads, Platt, and Harvey,⁷ however, reported that, in the Palanquin nuclear excavation experiment, sagebrush appeared much more sensitive to fallout than predictions based on experiments with gamma radiation from a ⁶⁰Co source indicated that it should be. This finding led to the proposal that the sagebrush retained fallout particles relatively efficiently and that the beta component of the fallout radiation was important in producing the observed effects. It is now generally recognized that plant tissues near exposed plant surfaces are vulnerable to external beta radiation.⁸ The dose received by such tissues as meristems may be large because of the high linear-energy-transfer coefficient of beta radiation.

Within the last several years, a number of studies have been initiated using laboratory-produced radioactive particles as a fallout simulant; beta and gamma radiations were considered independently. Witherspoon and Taylor⁹⁻¹¹ studied the effects of external beta radiation, including the effect from simulated fallout particles, on higher plants and determined the doses necessary to produce various degrees of response. Apical meristems were killed by beta-bath doses of 925 rads in white pine, 2315 rads in red oak, and 5400 rads in cocklebur when the doses were administered over a 1- to 3-day period. Other studies employed beta-emitting gauze strips applied to leaves¹² and cylinders placed over buds⁹ to study external beta effects. Lane and Mackin,¹² who studied bean plants, were among the first to approach the issue of external beta radiation, and their data indicated that beta doses of 100,000 rads to leaves and 2000 rads to whole plants produced sterility. None of the relatively few reports concerning the gross

effects of external beta radiation on plants have dealt with entire plant communities.

The primary objective of this study is to determine, qualitatively and quantitatively, the changes that occur in a natural plant community due to an acute exposure to external beta radiation from particles of a size range found in close-in fallout. Related objectives are (1) to describe the pattern of the radiation field produced by simulated fallout; (2) to obtain an index of the severity of beta effects relative to gamma effects observed in other studies, i.e., an ecological relative biological effectiveness factor (RBE); and (3) to describe some of the relations of structure and function in an ecosystem exposed to environmental stress.

THE GRANITE-OUTCROP ECOSYSTEM

Plants occur in small communities wherever soil accumulates in depressions on granite outcrops in the southeastern United States. The communities are found in small, often circular, depressions as well as in strips along the edges of forests adjacent to the rock. There are approximately 40 plant species that are considered characteristic of these communities although more than twice that many may occur in a community.^{1,3} The species are zoned within the communities in response to intensity gradients of biotic and abiotic factors, soil depth and soil moisture being most important. The larger, deeper-rooted plants occur in the deeper soil, and in circular communities the zones are represented by concentric bands of the various species.

The same attributes that favored the use of outcrop communities in the early work with gamma radiation¹ are also favorable attributes for analysis of beta-radiation effects. Their relatively simple composition and well-defined boundaries make them especially attractive for experimentation. An entire community can be studied as a microcosm, or small segments can be isolated and studied independently. Simulated rock outcrops can be constructed of concrete, as they have been at Emory University and the University of North Carolina, and the small ecosystems transplanted for more closely controlled investigation.^{1,4}

There is an extensive literature dealing with various aspects of granite-outcrop ecosystems. Lugo^{1,5} presented a survey of this literature along with energy, water, and carbon budgets for the system. The first published reports of an ecosystem experimentally irradiated in nature dealt with a granite-outcrop ecosystem,^{1,16-18} and data from these early studies showed that gamma radiation from ⁶⁰Co had both stimulatory and inhibitory effects on plant growth. Species interactions at the community level reflected radiation effects on individual plants.

The small size, relative simplicity, and adaptability for transplantation make these systems ideal experimental units. The considerable history of ecological research further enhances their suitability. For these several reasons the

granite-outcrop ecosystem was selected for initial studies of the ecological effects of beta radiation from simulated fallout particles.

METHODS

Simulated Outcrops

Five experimental communities were transplanted from Mt. Arabia, Ga., to two large concrete pads in the North Carolina Botanical Garden. Each pad had four circular depressions 2 m in diameter and 20 cm deep which had previously been coated with a thin layer of tar and covered with powdered granite as described by Cumming¹⁹ to simulate the natural granite substrate. A sampling grid of 20- by 40-cm quadrats was established in each community. Four of the communities, in the process of being treated with fallout simulant, are shown in Fig. 1.



Fig. 1 Simulated granite-outcrop communities in the process of being treated with fallout simulant.

Each circular community was divided through the center by a plexiglass sheet 1 cm thick and 1.2 m high. One-half of each of four communities was treated with radioactive fallout simulant, and the other half served as a control. (Each semicircle is referred to as a community.) A "low" dose of beta radiation was administered to two of the communities and a "high" dose to the other two. One-half of the fifth divided circular community was treated with nonradioactive fallout simulant as a control on physical particle effects. In studying radiation effects, we compared each irradiated community (semicircle) with the immediately adjacent control community on the opposite side of the plexiglass partition.

The summer flora was selected for irradiation. Between June and October the annual herb *Viguiera porteri* (A. Gray) Blake, a member of the Asteraceae, dominates the outcrop community. Since the structure of the summer community is most dependent on this species, *Viguiera* was studied more intensively than the other species were.

Irradiation and Dosimetry

The fallout simulant, supplied by Stanford Research Institute (SRI), consisted of albite (sodium feldspar) particles 44 to 88 μ in diameter with the beta-emitting isotope ^{90}Y overcoated on the particles with sodium silicate. Yttrium-90 has a 64.2-hr half-life and a beta energy of 2.26 MeV. The isotope solubility was 0.1 to 0.01%. These properties provided for an acute exposure to beta radiation from particles of a size range found in close-in fallout.

The simulant was dispersed on July 31, 1969. Two communities were treated with simulant of 1.85 mCi/g activity, and the other two received simulant of 4.74 mCi/g. The density dispersed was the same in all applications, 111 g per square meter of plant community (each community was 1.9 m² in area). The doses obtained from these applications were intended to be within a range capable of causing biological effects in outcrop plants, as previously shown in gamma-field studies.¹⁸ Nonradioactive fallout simulant was applied to one-half of the fifth divided community (111 g/m²).

The experiment most closely resembled conditions expected at a site 170 miles downwind of a 2.5-Mt detonation with a wind velocity of 15 mph according to calculations by Lane (personal communication) based on the procedures of Clark and Cobbin.²⁰

A hand-held applicator consisting of two concentric plastic cylinders, the central cylinder containing the fallout simulant and the space between the two cylinders containing water for shielding, was used to disperse the simulant over the communities (Fig. 1). A sampling grid was used to help keep the distribution of particles uniform. After fallout dispersal the communities were covered with a light cheesecloth tent for 1 week to reduce wind velocity and fallout redistribution from the concrete pad to the surrounding area. A 1.5-cm rainfall 24 hr after fallout dispersal washed all visible particles off exposed surfaces of

the vegetation onto the soil surface. No radioactive particles were detected with a portable G-M counter off the concrete pad containing the experimental communities.

Lithium fluoride thermoluminescent dosimeters (3 mm square and 1 mm thick), wrapped in light-shielding material and sealed in polyethylene packages, were placed in all treatment and control communities at two vertical levels (ground surface and 40 cm above the ground) on thin wooden rods. Forty-five dosimeters were placed in each treatment community and 12 in each control community. The 40-cm height represented the average height of terminal buds in the summer-dominant *Viguiera porteri*. When Landauer & Co. read the dosimeters after a 33-day exposure, less than 0.1% of the initial radioactivity remained. Landauer's values were then multiplied by a correction factor of 1.18 determined from exposure of six dosimeters to known dose levels of beta radiation from a calibrated ^{90}Y source²¹ by J. Mackin at SRI.

Ten glass-vial dosimeters containing lithium fluoride were arranged vertically on a string, five in each of the high-dose communities. These dosimeters, which were collected after the first 27 hr of exposure by W. Lane of SRI, provided an estimate of initial dose rates and vertical stratification of doses before the fallout simulant was washed from the vegetation by rain.

The percentage of retention of the fallout simulant was estimated by using nonradioactive simulant. Twenty planchets (total area, 151 cm²) were placed on the soil surface, and the percentage of dispersed particles falling through the vegetation canopy into the planchets was determined on a weight per unit area basis. This experiment was repeated three times, and the results were averaged.

Twenty days after fallout dispersal, samples of terminal buds, leaf axils, leaf blades, and stems were collected from *V. porteri* plants in each irradiated community. Three surface and three subsurface (0.5-cm) soil samples were also collected from each community. To determine the relative radioactivity per unit area of plant parts and soil, we pressed all samples flat in planchets for counting. Stems and buds were sectioned longitudinally and oriented so that their external surfaces faced the detector.

Community Analysis

Ecosystem Metabolism

A Beckman Instruments, Inc., model 215 infrared gas analyzer was used to measure rates of net production and respiration, based on the difference between concentrations of carbon dioxide (CO₂) in ambient air and in air sampled from the experimental communities. Bourdeau and Woodwell²² reviewed infrared absorption techniques for measuring rates of CO₂ exchange. Lugo¹⁵ measured rates of CO₂ exchange in granite-outcrop communities using techniques similar to those presented here.

The gas-analysis system is shown in Fig. 2. The transparent metabolism chamber (Fig. 3) was partitioned through the center so that air could be sampled alternately from control and treatment communities. Two fans approximately 50 cm in diameter, one in each half of the chamber, supplied an airflow averaging 34 cm/sec across each community and maintained the internal

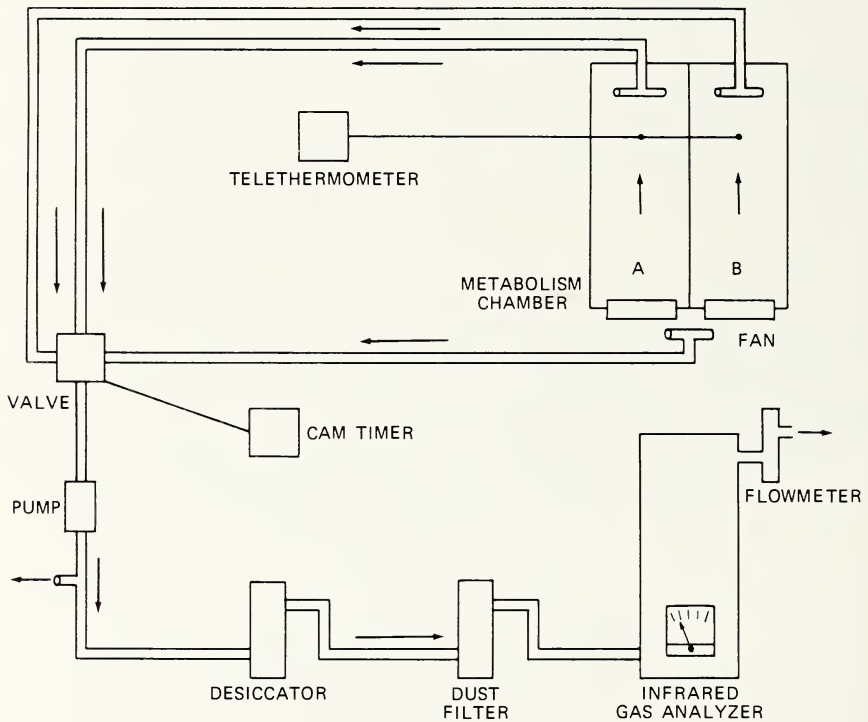

Fig. 2 Diagram of the system used to measure rates of CO_2 exchange in the experimental outcrop communities. Arrows indicate direction of airflow.

chamber temperature within $\pm 3^\circ\text{C}$ of outside ambient air. Airflow was measured at nine points over the cross section of each half of the chamber with a hot-wire anemometer. On the average, the volume of air in each half of the chamber was replaced 13 times per minute. Known concentrations of CO_2 in nitrogen were used to calibrate the gas analyzer.

The following relation was used to convert differences between CO_2 concentrations in ambient air and those in chamber air to rates of ecosystem net production or nighttime respiration in grams of carbon per square meter of ecosystem per hour ($\text{g C/m}^2/\text{hr}$):

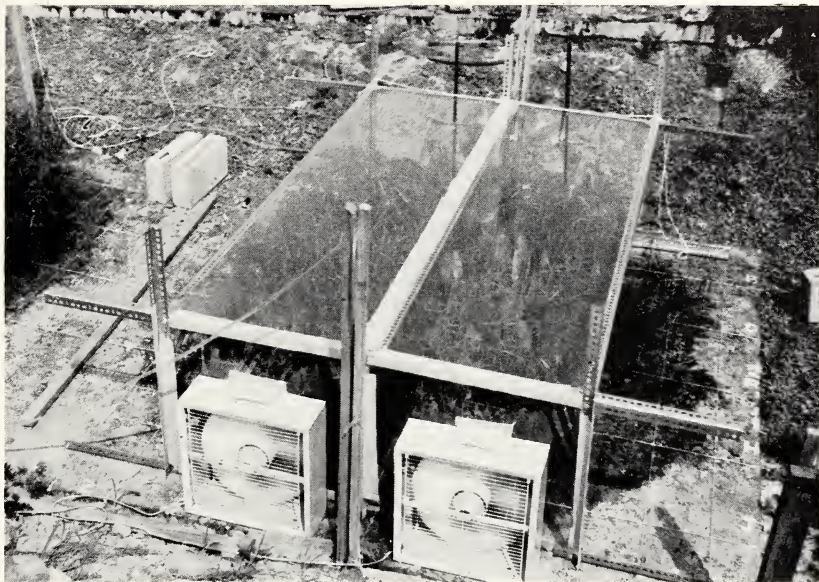

Fig. 3 Transparent chamber used for measuring rates of ecosystem CO₂ exchange. The chamber is shown in position over one of the experimental outcrop communities.

g C/m²/hr =

$$\frac{\text{flow rate} \times \text{difference} \times \frac{273}{\text{temp. in } ^\circ\text{K}} \times \frac{12 \text{ g C/mole}}{22.4 \text{ liters/mole}} \times 60 \text{ min/hr}}{\text{(liters/min)} \times \text{in CO}_2 \text{ (ppm)} \times \frac{273}{\text{temp. in } ^\circ\text{K}} \times \frac{12 \text{ g C/mole}}{22.4 \text{ liters/mole}} \times 60 \text{ min/hr}}{\text{ecosystem area (m}^2\text{)} \times 10^6 \text{ } \mu\text{l/liter}}$$

Measurements of CO₂ exchange rates were taken over a 4-day period 12 days before fallout dispersal and over a 4-day period 43 days after fallout dispersal. Each of the four irradiation and control communities was measured for one clear, sunny day before and after the irradiation period. Ambient-air and chamber-air samples were analyzed at the following times during the day for calculation of rates of net production: 9:30 to 10:10 a.m., 12 noon to 1:10 p.m., and 4:00 to 4:40 p.m. To calculate a reference rate of nighttime respiration, we analyzed ambient-air and chamber-air samples between 9:30 and 10:10 p.m. These rates were considered representative of early nighttime only (Lugo¹⁵ found rates of nighttime respiration in outcrop communities to be maximum between 9:30 and 10:10 p.m. in June 1968). Each half of the divided chamber and the ambient air were sampled for 10 min in a 30-min cycle during each of the sampling periods. Ten readings were taken during each 10-min period.

Species Composition

All plants were identified and counted in each of the communities 20 days before and 56 days after fallout dispersal. For lichens, mosses, and sedges, percent cover rather than numbers of individuals was estimated by using a 20-cm² wire frame as a gauge.

Biomass

One 20- by 40-cm quadrat was harvested from the center of each community 69 days after fallout dispersal. The plants in each sample (almost exclusively *V. porteri*) were divided into stem (with roots), leaf, and flower-head portions, oven dried for 24 hr at 105°C, and weighed.

Leaf-Area Index

The ratio of leaf area to ground area was estimated in all communities by suspending a weighted string over each intersection of grid lines (15 measurements per community). The number of leaves (of any plants) touching the vertical string was taken as an estimate of leaf-area index, and an average value was calculated for each community. This method was developed by Odum.^{2,3} The estimation was made 4 days before and 49 days after fallout dispersal.

Canopy Stratification

To determine the magnitude of the shift in canopy height with plant growth, we positioned a graduated aluminum rod perpendicular to the ground at each intersection of grid lines (15 per community) and recorded the height of all leaves touching the rod. The number of leaves in each increment of height above the ground for the 15 positions was calculated. This measurement was taken 4 days before and 49 days after fallout dispersal in all communities.

Litter Accumulation

Four aluminum pans with a total area of 380 cm² were placed in each experimental community to catch fallen plant debris. The oven-dry (24 hr at 105°C) weight of accumulated matter was determined 54 and 82 days after fallout dispersal. The mean weight per community was converted to a square meter basis.

Analysis of the Summer-Dominant *Viguiera porteri*

Height Growth

The distance from ground level to terminal buds was measured 20 days before and 56 days after fallout dispersal in 60% or more of all *Viguiera* plants in

all communities. The measured individuals were selected at random. Growth was expressed as percent increase in height during the period between fallout dispersal and the measurement 56 days later.

Terminal Bud Mortality

The terminal buds of 50 randomly selected *Viguiera* plants in each community were classified 70 days after fallout dispersal as either normal or dead, based on whether they showed signs of growth. The number of dead buds was expressed as a percentage of the 50 buds observed in each community.

Pigment Diversity

To document a possible change in coloration, we determined the yellow-to-green-pigment ratio²⁴ (Margalef ratio) 21 days before and 65 days after fallout dispersal. Pigments were extracted from three samples of three leaves each from each community. Leaves were ground in 90% acetone to extract pigments.²⁵ Optical densities of the samples were measured with a spectrophotometer at two wavelengths, 430 and 665 $m\mu$. The ratio of the optical density at 430 $m\mu$ to that at 665 $m\mu$ was taken as the pigment-diversity ratio.

RESULTS

Dosimetry

Dose levels obtained on the ground and in the vegetation canopy are given in Table 1. In the low-dose communities, the mean ground-surface dose (4824 rads) was 1.6 times higher than the mean canopy dose (2996 rads). In the high-dose communities, the ratio of mean ground-surface dose (8770 rads) to mean canopy

Table 1
MEAN COMMUNITY DOSE LEVELS AFTER 33 DAYS OF
EXPOSURE TO FALLOUT SIMULANT*

Treatment	Dose, rads		Mean (canopy and surface)
	Soil surface	Canopy	
Low dose	4824 \pm 882	2996 \pm 326	4037 \pm 768
Control	1.5 \pm 0.3	2.0 \pm 0.2	1.8 \pm 0.2
High dose	8770 \pm 676	5092 \pm 743	7082 \pm 38
Control	3.0 \pm 2.0	4.5 \pm 1.7	3.8 \pm 1.8

*Each value (\pm 1 standard error) represents the mean of two replicate communities.

dose (5092 rads) was 1.7. The mean integrated high dose (mean of ground and canopy) was 7082 rads, 1.8 times higher than the mean integrated low dose (4037 rads).

The doses recorded by the glass-vial lithium fluoride dosimeters after their 27-hr exposure in the high-dose communities are shown in Fig. 4. About a third (2000 rads) of the mean integrated dose (7082 rads) was received during the initial 27-hr period in the high-dose communities. Ground-surface doses were 1.8 times higher than canopy doses during the early period.

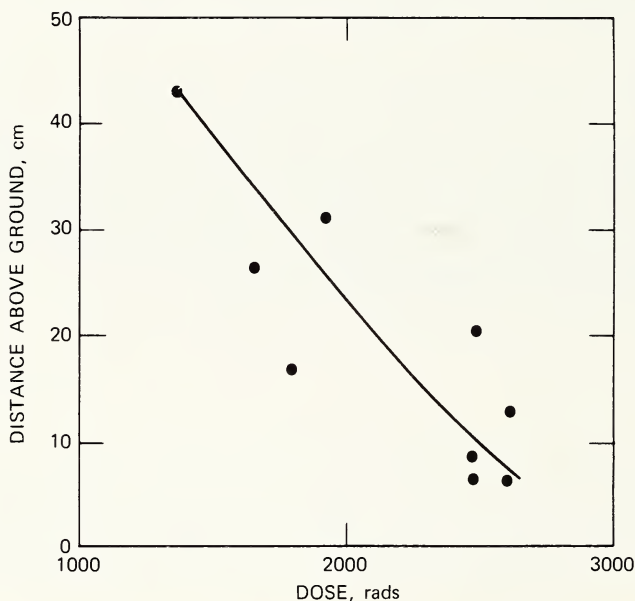

Fig. 4 Initial 27-hr doses recorded by the 10 lithium fluoride dosimeters in the high-dose communities.

Experiments with nonradioactive fallout simulant showed that 40% by weight of all particles dispersed over the communities was initially retained on vegetation. The radioactivity per unit area of plant surfaces relative to that of the soil surface 20 days after fallout dispersal is shown in Fig. 5. The surfaces of leaf axils and terminal buds apparently collected more radioactive particles than did other plant parts, but even these surfaces were only 23 and 14%, respectively, as radioactive as the soil surface. The surfaces of leaf blades and stems were less than 5% as radioactive as the soil surface. At a depth of 0.5 cm, there was no radioactivity above background in the soil.

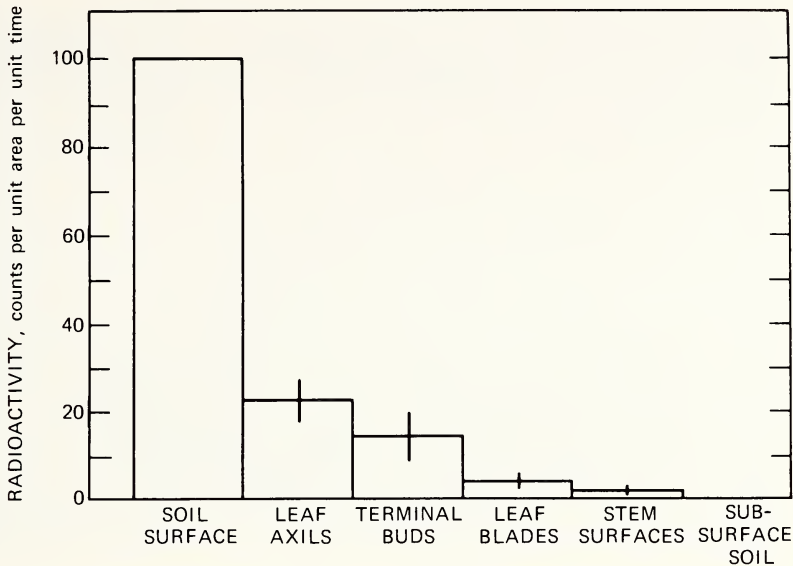

Fig. 5 Mean radioactivity of *Viguiera porteri* plant parts relative to the radioactivity of the soil surface. Vertical lines indicate ± 1 standard error of the mean.

Response of the Plant Community

General Appearance

Beta radiation did not change the overall appearance of the experimental communities (Fig. 6). Changes in community structure required close observation and measurement for detection.

Ecosystem Metabolism

Mean rates of net production for replicated communities between 9:30 a.m. and 4:40 p.m. on clear days, before and after irradiation (July and September, respectively), varied from 1.0 to 1.4 g C/m²/hr (Table 2) and averaged 1.2 in both months. There was no change in the overall balance of CO₂ exchange during the daytime between July and September in control or irradiated communities when replicate values were averaged. Representative curves of rates of net production, based on the three periods of daytime measurement, and curves of solar radiation and metabolism-chamber temperatures are shown in Fig. 7.

For the 40-min dark period measured each night (9:30 to 10:10 p.m., the period of maximum nighttime respiration rates as shown by Lugo¹⁵), respiration



Fig. 6 Experimental outcrop community approximately 6 weeks after application of fallout simulant. The right half of the community received a mean dose of 7000 rads, and the left half, shielded by a plexiglass sheet, was a control.

Table 2

MEAN RATES OF NET PRODUCTION (NP) IN THE EXPERIMENTAL COMMUNITIES BETWEEN 9:30 A.M. AND 4:40 P.M. IN JULY AND SEPTEMBER*

Treatment	July (preirradiation)		September (postirradiation)	
	Date	NP, g C/m ² /hr	Date	NP, g C/m ² /hr
4000 rads	17, 18	1.4 ± 0.6	15, 16	1.4 ± 0.4
Control	17, 18	1.2 ± 0.3	15, 16	1.2 ± 0.1
7000 rads	16, 19	1.0 ± 0.1	13, 14	1.1 ± 0.2
Control	16, 19	1.0 ± 0.3	13, 14	1.0 ± 0.1

*Each value (±1 standard error) is based on 80 readings of CO₂ exchange rates and represents the mean of two replicate communities.

rates for replicated communities varied from 1.7 to 3.6 g C/m²/hr (mean, 2.9) before irradiation in July and from 1.2 to 4.0 g C/m²/hr (mean, 2.2) after irradiation in September (Table 3). In six of the eight communities, the rate of respiration declined between July and September. In two communities (7000 rad and 7000-rad control), the rate increased.

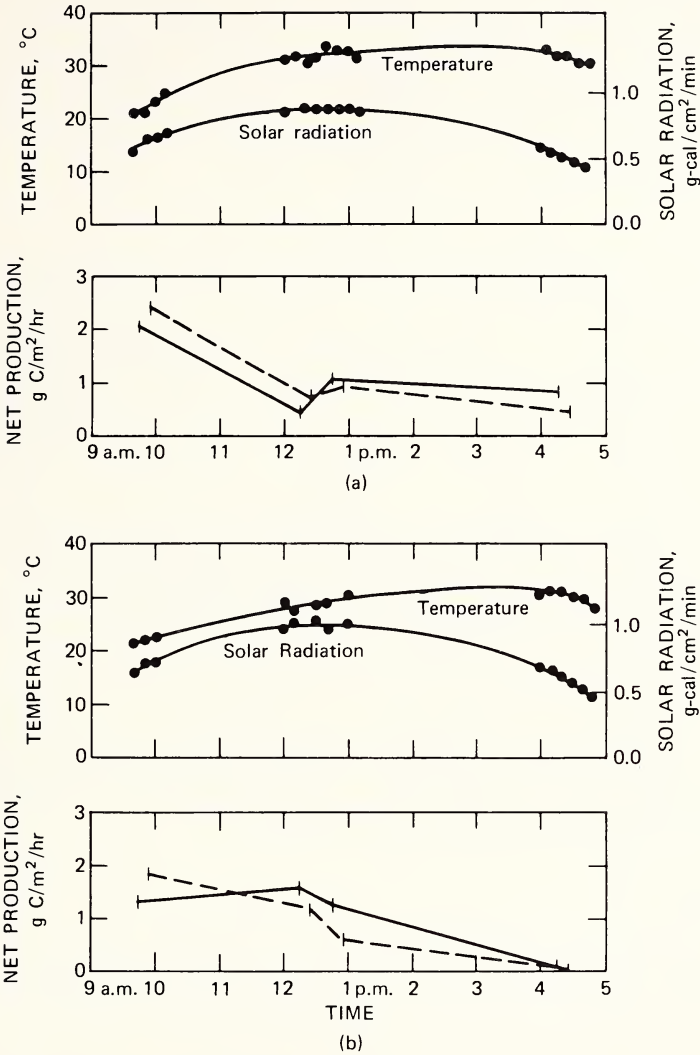

Fig. 7 Representative curves of solar radiation, chamber-air temperature, and rates of net production in the experimental outcrop communities 43 days after fallout dispersal. (a) 4000-rad community on September 16. (b) 7000-rad community on September 14. ---, net production rates for irradiated communities; —, net production rates for control communities; |, ± 1 standard error of the mean.

Species Composition

The summer flora of the simulated outcrop communities consisted of the following species: *Viguiera porteri* (A. Gray) Blake (Asteraceae), *Senecio tomentosus* Michx. (Asteraceae), *Talinum teretifolium* Pursh. (Portulacaceae), *Crotonopsis elliptica* Willd. (Euphorbiaceae), *Hypericum gentianoides* (L.) BSP. (Hypericaceae), *Bulbostylis capillaris* (L.) Clarke (Cyperaceae), *Polytrichum commune* Hedw. (Polytrichaceae), and *Cladonia* sp. (Cladoniaceae).

Table 3

MEAN RATES OF RESPIRATION (R) IN THE EXPERIMENTAL COMMUNITIES BETWEEN 9:30 AND 10:10 P.M. IN JULY AND SEPTEMBER*

Treatment	July (preirradiation)		September (postirradiation)	
	Date	R, g C/m ² /hr	Date	R, g C/m ² /hr
4000 rads	17, 18	3.6 ± 0.2	15, 16	1.6 ± 1.1
Control	17, 18	1.7 ± 0.5	15, 16	1.2 ± 0.8
7000 rads	16, 19	2.7 ± 0.9	13, 14	1.8 ± 1.4
Control	16, 19	3.6 ± 1.6	13, 14	4.0 ± 0.1

*Each value (±1 standard error) is based on 20 readings of CO₂ exchange rates and represents the mean of two replicate communities.

In only one species, *B. capillaris*, was there a reduction in quantity (percent cover) which appeared related to radiation. The percent cover of this sedge increased by an average of 12% in control and 4000-rad communities but decreased by 17% in the 7000-rad communities.

Biomass

Nearly 100% of all plants in the biomass samples were *V. porteri*. Total biomass was unrelated to the number of plants in the harvested quadrats (Table 4). Of the four irradiated communities and their controls, total biomass was least in the 7000-rad communities (585 g/m², or 16% less than in the 7000-rad control communities). The reduction was due to a lower production of flower and stem biomass. Leaf biomass was similar to control levels in all irradiated communities.

The community treated with nonradioactive fallout simulant and its control had 250 and 200 g/m² total biomass, respectively, or about 64% less than the other communities (Table 4). These communities were transplanted 1 year later than the others and were more sparse in appearance. Nonradioactive fallout simulant did not reduce biomass production.

Table 4

BIOMASS OF *Viguiera porteri* IN OCTOBER, 69 DAYS AFTER FALLOUT DISPERSAL*

Treatment	Mean number of plants	Dry weight, g/m ²			
		Stems	Leaves	Flower heads	Total
4000 rads	16	485 ± 25	118 ± 12	82 ± 5	681 ± 32
Control	28	460 ± 86	99 ± 14	72 ± 5	631 ± 106
7000 rads	13	425 ± 60	112 ± 20	55 ± 12	585 ± 35
Control	24	496 ± 35	105 ± 19	92 ± 2	693 ± 19
Nonradioactive fallout†	20	166	45	38	250
Control†	33	125	46	30	199

*Each value (± 1 standard error) represents the mean of two replicate communities unless otherwise indicated.

†Each value represents one community.

Table 5

MEAN LEAF-AREA INDEX AND PERCENT INCREASE BETWEEN JULY AND SEPTEMBER*

Treatment	July (preirradiation)	September (postirradiation)	Percent increase
4000 rads	2.4 ± 0.3	3.2 ± 0.2	34 ± 8.6
Control	2.2 ± 0.2	3.2 ± 0.4	53 ± 31.5
7000 rads	1.6 ± 0.2	1.9 ± 0.2	19 ± 2.0
Control	1.6 ± 0.1	2.5 ± 0.5	54 ± 21.5
Nonradioactive fallout†	1.1	1.3	18
Control†	0.8	0.9	12

*Each value (± 1 standard error) represents the mean of two replicate communities unless otherwise indicated.

†Each value represents one community.

Leaf-Area Index

Mean leaf-area index varied from 1.6 to 3.2 in the irradiated communities and in their controls and was variable (Table 5). The 7000-rad communities showed a smaller increase in leaf-area index (19%) than controls (54%) for the 49-day period after fallout dispersal. The final leaf-area index in the 7000-rad communities (1.9) was 24% lower than that in the control communities (2.5).

The final leaf-area index in the 4000-rad communities and in their controls was the same (3.2). The index increased 6% more in the community treated with nonradioactive fallout simulant than in the control.

Canopy Stratification

The increase in height of the plant canopy (almost 100% *V. porteri*) during the growing season between July and September is obvious in all communities in Fig. 8. In the 7000-rad communities, there was a maximum concentration of leaves 50 cm above the ground in September, whereas in the controls the leaves were more uniformly distributed between about 40 and 70 cm in height. The vertical distribution of leaves in the 4000-rad communities was similar to that in the controls. All irradiated and control communities showed a decrease in the number of lower leaves with increase in plant height, a natural phenomenon.

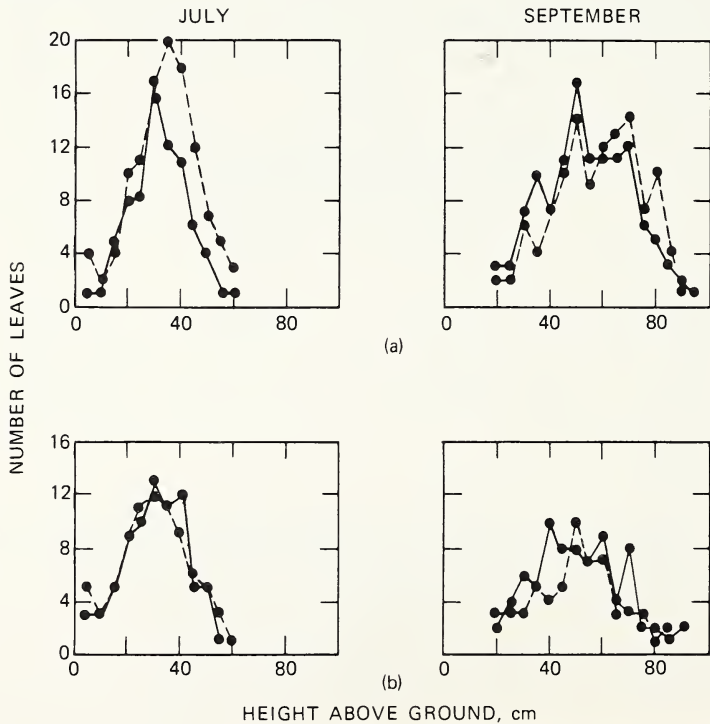

Fig. 8 Canopy stratification in the experimental outcrop communities. The total number of leaves at various heights in the canopy is shown for the 15 measured locations in each irradiated and control community. (a) 4000-rad communities. (b) 7000-rad communities. ---, irradiated communities; —, control communities.

Litter Accumulation

During the 56-day period between July 29 and September 23, the daily litter accumulation was 33% greater in the 7000-rad communities than in the controls (Table 6). In the 4000-rad communities, the daily accumulation was 20% less than in the controls. During the 28-day period between September 23 and October 21, the daily accumulation was 44% greater in the 7000-rad communities than in the controls. In the 4000-rad communities, the daily accumulation was 18% less than in the controls.

Table 6
MEAN DAILY LITTER ACCUMULATION DURING TWO
CONSECUTIVE PERIODS FOLLOWING FALLOUT DISPERSAL*

Treatment	Accumulation, g/m ² /day	
	July 29 to Sept. 23	Sept. 23 to Oct. 21
4000 rads	0.4 ± 0.1	3.6 ± 0.1
Control	0.5 ± 0.2	4.4 ± 0.1
7000 rads	0.4 ± 0.1	4.9 ± 0.8
Control	0.3 ± 0.1	3.4 ± 0.4

*Each value (±1 standard error) represents the mean of two replicate communities.

Response of the Summer-Dominant *Viguiera porteri**Height Growth*

Percent increase in height in *V. porteri*, adjusted for the 56-day period from August 1 (the day after fallout dispersal) to September 26, is given in Table 7. The mean percent height increase in the 7000-rad communities (55%) was 37% less than in the controls (92%). Growth may have been slightly reduced in the 4000-rad communities, but the standard errors of the means indicated that there was considerable overlap of growth values between irradiated and control communities. Increase in height in the community treated with nonradioactive fallout simulant was 91% and in the control 93%.

Terminal Bud Mortality

Beta radiation killed 46% of the terminal buds in the 7000-rad communities and 16% in the 4000-rad communities (Table 7). The frequency of dead terminal buds ranged from 2 to 4% in control communities. The stunted appearance of a *V. porteri* plant with a dead terminal bud and the compensatory development of

Table 7
 MEAN PERCENT HEIGHT INCREASE DURING THE 56-DAY PERIOD
 FOLLOWING FALLOUT DISPERSAL AND PERCENT TERMINAL-BUD
 MORTALITY IN *Viguiera porteri**

Treatment	Height increase, %	Terminal- bud mortality, %
4000 rads	87 ± 4	18 ± 2
Control	92 ± 4	2 ± 2
7000 rads	55 ± 4	49 ± 3
Control	92 ± 5	3 ± 1
Nonradioactive fallout†	91	4
Control†	93	4

*Each value (± 1 standard error) represents the mean of two replicate communities unless otherwise indicated.

†Each value represents one community.

lateral branches can be seen in Fig. 9. Nonradioactive fallout simulant did not affect terminal-bud development, but there was 4% mortality in both treated and control communities.

Pigment Diversity

The yellow-to-green-pigment ratio was higher (mean, 5.2) toward the end of the growing season in October than in July (mean, 2.8) in all communities (Table 8). The optical density of pigment samples at both 430 and 665 $m\mu$ declined toward late summer, but the optical density at 665 $m\mu$ declined most, accounting for the increased ratio. There was no change in this ratio associated with irradiation. The ratio in the community treated with nonradioactive fallout simulant increased 23% more than that in its associated control community.

DISCUSSION

Fallout-Radiation Field

The radiation field from fallout simulant was vertically stratified in all communities. Doses on the ground surface exceeded those in the vegetation canopy 40 cm above the ground by 65%. Approximately a third of the integrated dose was delivered within the first 27 hr after fallout dispersal, during which time a maximum of 40 wt.% of the particles still resided on the vegetation. During the remainder of the exposure period, all visible particles were on the soil surface owing to a heavy rain 24 hr after fallout dispersal. No radioactive particles were detected 0.5 cm beneath the soil surface.

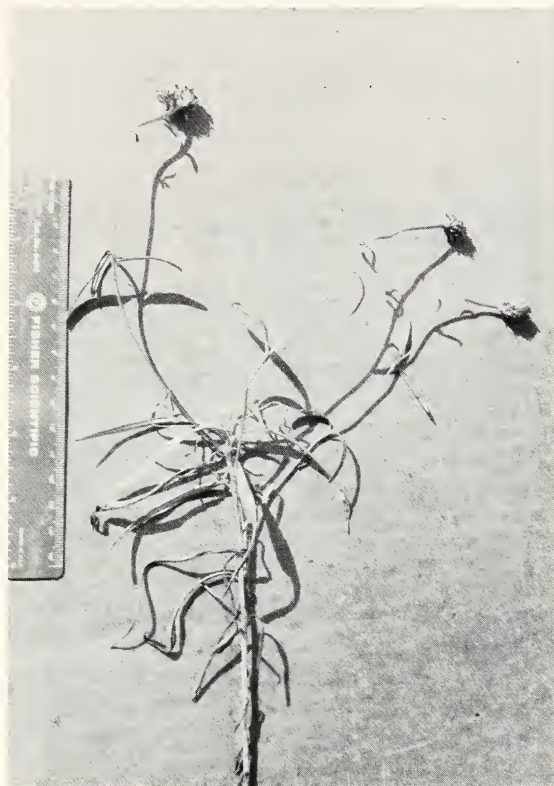

Fig. 9 *Viguiera porteri* plant with dead terminal bud. The ruler is 15 cm long.

The mean integrated beta-bath and contact dose levels recorded by the dosimeters cannot be directly related to all the observed biological effects. Certain plant parts, such as leaf axils and terminal buds, captured and retained fallout particles and doubtlessly received higher than average doses. The maximum doses recorded by some dosimeters may be better estimates of the contact dose received by terminal buds that were killed. Twenty-two percent of the dosimeters in the low-dose communities (mean dose, 4000 rads) gave values between 7000 and 10,000 rads, and 18% of the dosimeters in the high-dose communities (mean dose, 7000 rads) gave values between 11,000 and 13,000 rads. The dosimeters recording maximum doses were visibly coated with fallout simulant while the activity of the ^{90}Y was still high. These dose values may therefore approximate the actual doses received by some plant parts that trapped fallout simulant.

The data showed no negative biological response to nonradioactive fallout simulant applied at the same density (111 g/m^2) as the radioactive simulant. A

Table 8
MEAN MARGALEF PIGMENT-DIVERSITY RATIOS IN
Viguiera porteri IN JULY AND SEPTEMBER*

Treatment	Pigment-diversity ratio	
	July (preirradiation)	September (postirradiation)
4000 rads	2.86 ± 0.06	5.11 ± 0.21
Control	2.80 ± 0.06	5.00 ± 0.16
7000 rads	2.75 ± 0.02	5.18 ± 0.14
Control	2.76 ± 0.04	5.36 ± 0.48
Nonradioactive fallout†	2.72	5.81
Control†	2.87	4.78

*Each value (± 1 standard error) represents the mean of two replicate communities unless otherwise indicated.

†Each value represents one community.

pilot study (unpublished data) showed no changes in rates of CO₂ exchange of several species of small herbs treated with 111 g/m² and higher densities of nonradioactive fallout simulant. It was interpreted that the effects observed in this study were due to beta radiation and not the fallout particles themselves.

Questions relating to four of the objectives of this study can now be considered: (1) What were the effects on the overall integrated functioning, or metabolism, of the system? (2) What were the effects on the community structure, and how did these effects relate to the overall metabolism? (3) How did the severity of beta effects compare with that of gamma in earlier studies?

Ecosystem Metabolism

Odum²⁶ defined stress as the drain of calories of potential energy flow and noted that the change in energy flow in a stressed system can be used as a measure of the stress. "The stress of a disordering, damaging radiation," he pointed out, "resembles an increase in temperature by increasing the rate of random deformations of microscopic structures necessary to regular work and maintenance processes." Energy is thus diverted from the production of biomass to maintenance processes; therefore rates of net photosynthesis would be expected to decrease and rates of respiration to increase.

A measure of energy flow in ecosystems is metabolism, as measured by determining rates of CO₂ exchange. The CO₂ exchange data showed no sign of beta-radiation stress when the outcrop communities were measured 43 days after fallout dispersal. The rates of net production in grams of carbon per square meter per hour obtained in this study (mean daytime rate, 1.2 in both July and

September) agree closely with measurements by Lugo¹⁵ in very similar simulated outcrop plant communities during the previous summer (mean, 1.3). According to most measurements in this study, maximum rates of net production occurred in the morning, during which time the concentration of CO₂ in the air around the communities was still high (27% higher at 9:30 a.m. than at 12 noon), temperatures were relatively low (32% lower at 9:30 a.m. than at 12 noon), soil-moisture conditions were most favorable, concentrations of nutrients in the soil from the previous night's respiration were still high, and photorespiration effects were low. Morning rates of net production were also found to be maximum by Lugo.¹⁵

Rates of nighttime respiration during the 40-min measurement period from 9:30 to 10:10 p.m. declined from a mean of 2.9 g C/m²/hr in July to 2.2 in September. This decline was likely caused by the facts that the nighttime ambient-air temperature was about 9°C cooler in September and the daily accumulation of labile organic matter was less because of lower light intensities. There was a slight increase in rates of nighttime respiration in one control and one irradiated community.

Measured rates of nighttime respiration were higher than mean rates of net production, but the respiratory rates were representative of only a short period during the early part of the night. Lugo¹⁵ reported rates of respiration averaging 6.1 g C/m²/hr during the same period of the night in similar communities in June, but he found the average rate for the entire night to be much lower (1.6 g C/m²/hr). These initial high rates, which occur while storages of organic matter produced during the preceding daytime period are maximum, demonstrate the importance of restricting comparisons to values obtained during equivalent time periods.

Carbon dioxide exchange has been used before to measure metabolic effects of ionizing radiation stress. Hadley and Woodwell²⁷ showed that acute exposure to as little as 1250 R of gamma radiation depressed rates of net photosynthesis in pine leaves without affecting rates of CO₂ evolution in the dark. In pine stems rates of CO₂ evolution were initially stimulated but ultimately depressed. Woodwell²⁸ found that irradiation at 33 R/day (total dose unspecified) depressed both rates of CO₂ fixation and respiration in a forest ecosystem, net photosynthesis being depressed more than respiration.

The extent to which metabolic data can be expected to reflect stress-induced changes in the energy flow of an ecosystem depends on the system and the time of measurement. Natural ecosystems are capable of repair, through succession, but the ease with which the system is disrupted and the rates of repair which follow can be expected to vary depending on the nature of the biological components of that system and the extent of damage done. Systems composed of small units depend more on replacement to maintain themselves than do systems composed of large units.²⁶ A forest would take longer for repair than an actively growing algal culture, and the measurable metabolic effects in the forest would presumably be evident for a longer time after the stress was removed. This

is not to say that the algal culture would not be more vulnerable to extinction than the complex forest system.

The situation in the outcrop communities is similar to that in an old field, and, as Woodwell²⁸ pointed out, species diversity appears to be a more sensitive indicator of radiation response than organic production, although the significance of this response is incompletely understood. Radiosensitive species in an old field are eliminated by radiation, but they are replaced by species that are radioresistant, bringing about changes in the relative importance of plant populations without necessarily causing changes in total biomass. That the ratio of primary production to biomass is increased in the less diverse system is an indication of successional setback in systems with initial low diversity.^{3,29} Radiation-induced reduction in species diversity has been observed in outcrop communities. Garrett³⁰ found a decline in diversity associated with gamma irradiation, and McCormick and Platt¹⁸ noted the expansion of the sedge *Bulbostylis capillaris* into the zone that had been occupied by *Viguiera porteri* in an outcrop community that received more than 30,000 R of gamma radiation.

Community Structural Response

Only one plant species exhibited immediate mortality in the experimental outcrop communities. The percent cover of *Bulbostylis capillaris* declined by 17% in the 7000-rad communities, whereas it increased by an average of 12% in the other communities. Gamma-radiation studies indicated that this species is radioresistant,¹⁸ but, since *B. capillaris* (a sedge) has growing apexes close to the ground, it may have retained high densities of fallout particles in close proximity to sensitive meristems. The geometry of the fallout radiation field was such that the physical position of plants within the community was at least as important as their inherent degree of tolerance to radiation.

High levels of radioactivity on or near the soil surface (65% higher than at 40 cm above the ground) represent an important aspect of the radiation field. In the gamma-field studies, which provided the basis for predictions of effects of thermonuclear war on ecosystems, soil organisms, roots, seed, and plant meristems near the soil surface were afforded some protection by microrelief and litter. In fallout situations the soil component of the ecosystem, recognized as being an important pathway of energy flow, is more vulnerable, and the effects occurring in and near this component of the system warrant much closer study.

Viguiera porteri plants in the 7000-rad communities grew 37% less in height than did control plants over the 56-day period after fallout dispersal. The mean beta-bath dose received by the terminal portions of these plants was about 5000 rads. The total dose, including contact dose due to entrapped particles, is not known but is assumed to be higher, possibly approximated by the highest dosimeter doses (11,000 to 13,000 rads). McCormick and Platt¹⁸ found a 17% reduction in height growth in *V. porteri* plants that had accumulated a total dose

of 5000 R from gamma radiation (^{60}Co) over a 100-day period. A reduction equivalent to the 37% observed in this study required about 17,000 R. If the beta dose level responsible for the 37% reduction observed was assumed to be 5000 rads, the RBE for acute exposure to beta radiation relative to chronic exposure to gamma radiation would be about 3.4. If the dose levels responsible were considered to be near the maximum observed (11,000 to 13,000 rads), the RBE would be about 1.3. The actual RBE is probably near 2 for height-growth reduction in *V. porteri* under the conditions outlined.

The morphological explanation for the beta-radiation-induced height-growth reduction is quite clear. In the communities that received a canopy dose of 5000 rads, 18% of all *V. porteri* terminal buds were killed. Terminal buds were especially vulnerable to fallout irradiation since they were actively growing and retained more radioactivity per unit area than did other plant parts except for leaf axils.

The total biomass (*V. porteri* accounted for almost 100% of the harvested biomass) was 16% less in the 7000-rad communities than in the controls. The retarded height growth was most likely the main contributor to this reduction in biomass. Interestingly, however, there was no reduction in leaf biomass in any of the irradiated communities. The accelerated growth of lateral branches helped to provide a normal leaf biomass. Woodwell²⁸ noted an actual increase in total standing crop in an old field at exposures of up to 1000 R/day, but higher exposures caused a sharp decline in standing crop. In this study flower biomass was reduced by 40% in the 7000-rad communities. Reproduction is an energetically expensive process owing to the expenditure necessary to produce and organize complex structures (including complex molecules such as DNA) and the high caloric content of reproductive structures.³¹ Possibly some of the energy that would normally have been used in this process was instead diverted to the observed repair mechanisms (primarily lateral branch development). Normal rates of basal metabolism could not have been expected to supply the stress-induced demand for maintenance energy.

The final (September) leaf-area index was the same (3.2) in the 4000-rad communities and in their controls. The final leaf-area index in the 7000-rad communities was 1.9, 24% lower than in the controls. The fact that leaf-area index was reduced even though biomass of leaves was not can be explained by the orientation of leaves on the terminal shoots of the canopy plants (*V. porteri*). In plants with dead terminal buds, the leaves on the central shoot developed, but they were clustered together around the shoot apex because of the lack of internodal elongation. Clustered leaves resulted in an underestimation of leaf-area index as measured with the weighted-string method. The data on canopy stratification indicated that there was no essential difference between the vertical distribution of leaves in the 4000-rad communities and the controls. In the 7000-rad communities, however, there was a maximum concentration of leaves at 50 cm above the ground. This reflected the stunted nature of the

dominant *V. porteri* and contrasted with a more continuous vertical distribution of leaves at about 40 to 70 cm in the controls.

These differences in canopy structure in the 7000-rad communities, a lower leaf-area index and a more clustered vertical distribution of leaves, were results of terminal-bud mortality and the subsequent compensation by lower lateral branches after the reduction in terminal growth. The differences were not caused by radiation-induced leaf fall. Litter accumulation data gave no evidence of unusually fast rates of leaf fall until after the second leaf-area-index measurement had been taken. After that period, in October, the rate of daily litter accumulation was 43% more rapid in the 7000-rad communities than it was in the controls.

Pigment Diversity

Color changes in plants, especially in leaves, are a common effect of ionizing radiation.^{3,2} The visual indexes of discoloration sometimes used to document these changes seem inadequate. They are subjective and tell nothing about the cause of discoloration. The Margalef pigment-diversity ratio seems to be of value in this regard since leaf yellowing should be indicated by an increased yellow-to-green-pigment ratio. As the *V. porteri*-dominated outcrop communities progressed into senescence during the postirradiation period in September, they all appeared more yellow, and the pigment-diversity ratio increased from a mean of 2.8 in July to 5.2 in September. The increase was caused by a greater decline in green-pigment concentration than in yellow. The communities stressed with fallout, however, showed no excessive discoloration visually, and the pigment-diversity ratio in *V. porteri* gave no indication of any unusual yellowing relative to controls.

Homeostasis in the Outcrop Plant Community

The granite-outcrop plant community possesses plasticity, the intrinsic capacity for rapid repair relative to larger terrestrial systems. The community is able to quickly fill gaps in utilization of its resources because of the short life cycles of its component species, the array of life forms of these species,^{1,3} the specialized mechanisms of seed germination,^{3,3} and the high rates of primary production under favorable conditions.^{1,5} Not only is the herbaceous community able to replace eliminated components quickly but also the damaged components are in themselves capable of rapid compensation in structure for damaged parts. If new individuals do not actually fill the gaps, the remaining viable individuals will.

Harper^{3,4} pointed out that the plasticity shown by most plants makes sheer numbers a misleading measure of the actual amount of a species present. Plasticity in the outcrop community is illustrated by the fact that the biomass of *V. porteri* per unit area was unrelated to the number of plants per unit area. Ten plants in one area, in fact, produced more biomass (620 g/m²) than 48 plants in

a comparable area (525 g/m^2). Under normal environmental conditions an outcrop community is adapted to production of a particular organic matter and is stabilized against changes in that value through feedback mechanisms related to light, nutrient, and water supply. Removal of competing plants from within a population or from a different population, which relieves the demand on water and nutrient resources and allows the penetration of more light into the canopy, would help to explain the lack of relation between number of individuals and biomass. One of the consequences of a density stress on a plant population is a plastic response from the individuals as they adjust to share limiting resources.^{3,5}

The best example of an adjustment in outcrop-plant morphology to beta-radiation damage which helped maintain metabolic and structural homeostasis in the community was the development of lateral branches in *V. porteri* when the terminal buds were killed. Skoog^{3,6} attributed this common radiation effect to the destruction of auxin in terminal buds; this then releases lateral buds from apical dominance. Even when there was severe damage to individual plants, the general appearance and structure of the experimental communities were not greatly changed by beta radiation, owing primarily to lateral branch development.

This capacity for rapid adjustment may be partially explained by the fact that elements of the prevailing environmental conditions under which the outcrop ecosystem evolved are in themselves stresses. Woodwell^{2,8} suggested that plants capable of adjusting to environmental stresses are better able to cope with radiation stress. Outcrop plants possess such mechanisms. Periods of low rainfall and high temperatures are not unusual during the summer growing season.^{1,5} The ability to recover from extreme wilting has been shown in *V. porteri*.^{3,3} Lugo^{1,5} found that, under optimal conditions of temperature, light intensity, and moisture, outcrop communities are capable of much higher than average rates of net production. During unfavorable periods the rates of CO_2 exchange are much reduced; this conserves energy reserves.

In 1963 Margalef^{3,7} predicted the destruction of structure in ecosystems by ionizing radiation without any great change in energy flow. The primary reason for our not finding a change in rates of CO_2 exchange correlated with radiation damage in this investigation is that the community had compensated structurally by the time the measurements were taken. Physical signs of radiation damage in plants were visible at the time CO_2 exchange was measured, but the morphological adjustments made by these plants, primarily lateral branch development, compensated to the point where the system was able to maintain normal levels of energy accumulation and utilization.

ACKNOWLEDGMENTS

This research was sponsored by the U. S. Atomic Energy Commission under Contract AT-(40-1)-3299. Valuable advice was received from H. T. Odum and N. Underwood, faculty members of the University of North Carolina, W. B. Lane of Stanford Research Institute supplied the fallout simulant and advised in

matters regarding its dispersal, and J. Mackin, also of SRI, calibrated the dosimeters.

REFERENCES

1. J. F. McCormick, Ecological Analysis of Selected Granite Outcrop Communities and Their Response to Chronic Gamma Radiation, M.S. Thesis, Emory University, 1959.
2. G. M. Woodwell, Effects of Ionizing Radiation on Terrestrial Ecosystems, *Science*, **138**: 572-577 (1962).
3. R. B. Platt, Ionizing Radiation and Homeostasis of Ecosystems, in Ecological Effects of Nuclear War, G. M. Woodwell (Ed.), USAEC Report BNL-917, pp. 39-60, Brookhaven National Laboratory, August 1965.
4. E. P. Odum, Summary, in Ecological Effects of Nuclear War, G. M. Woodwell (Ed.), USAEC Report BNL-917, pp. 69-72, Brookhaven National Laboratory, August 1965.
5. G. M. Woodwell, Radioactivity and Fallout: The Model Pollution, *Bioscience*, **19**: 884-887 (1969).
6. G. M. Woodwell, Effects of Pollution on the Structure and Physiology of Ecosystems, *Science*, **168**: 429-433 (1970).
7. W. A. Rhoads, R. B. Platt, and R. A. Harvey, Radiosensitivity of Certain Perennial Shrub Species Based on a Study of the Nuclear Excavation Experiment, Palanquin, with Other Observations of Effects on the Vegetation, USAEC Report CEX-68.4, EG&G, Inc., October 1967.
8. S. L. Brown, Beta Radiation Effects on Agriculture, Technical Note TN-RMR-34, SRI Project No. MU-6250-052, Stanford Research Institute, 1968.
9. J. P. Witherspoon and F. G. Taylor, Jr., Effects of External Beta Radiation on Higher Plants, in Progress Report in Postattack Ecology, S. I. Auerbach (Ed.), USAEC Report ORNL-TM-2466, pp. 2-17, Oak Ridge National Laboratory, March 1969.
10. J. P. Witherspoon and F. G. Taylor, Jr., Effects of External Beta Radiation on Higher Plants, in Health Physics Division Annual Progress Report for Period Ending July 31, 1968, USAEC Report ORNL-4316, pp. 82-85, Oak Ridge National Laboratory, October 1968.
11. J. P. Witherspoon and F. G. Taylor, Jr., Effects of External Beta Radiation on Higher Plants, in Health Physics Division Annual Progress Report for Period Ending July 31, 1969, USAEC Report ORNL-4446, pp. 69-70, Oak Ridge National Laboratory, October 1969.
12. W. B. Lane and J. L. Mackin, Response of Bean Plants to Beta Radiation, SRI Project No. MU-6358, Stanford Research Institute, 1967.
13. M. P. Burbanck and R. B. Platt, Granite Outcrop Communities of the Piedmont Plateau in Georgia, *Ecology*, **45**: 292-306 (1964).
14. R. B. Platt and J. F. McCormick, Manipulatable Terrestrial Ecosystems, *Ecology*, **45**: 649-650 (1964).
15. A. E. Lugo, Energy, Water, and Carbon Budgets of a Granite Outcrop Community, Ph. D. Dissertation, University of North Carolina, 1969.
16. J. F. McCormick, Response of Selected Granite Outcrop Communities to Chronic Low-Level Gamma Radiation, *ASB (Ass. Southeastern Biol.) Bull.*, **7**: 37 (1960).
17. J. F. McCormick, Changes in a Herbaceous Plant Community During a Three-Year Period Following Exposure to Ionizing Radiation Gradients, in *Radioecology*, Proceedings of a Symposium, Sept. 10-15, 1961, Fort Collins, Colo., V. Schultz and A. W. Klement, Jr. (Eds.), pp. 271-276, Reinhold Publishing Corporation, New York, 1963.
18. J. F. McCormick and R. B. Platt, Effects of Ionizing Radiation on a Natural Plant Community, *Radiat. Bot.*, **2**: 161-188 (1962).

19. F. P. Cumming, An Experimental Design for the Analysis of Community Structure, M.S. Thesis, University of North Carolina, 1969.
20. D. E. Clark, Jr., and W. C. Cobbin, Some Relationships Among Particle Size, Mass Level, and Radiation Intensity of Fallout from a Land Surface Nuclear Detonation, Report USNRDL-TR-639, Naval Radiological Defense Laboratory, Mar. 21, 1963.
21. J. L. Mackin, S. L. Brown, and W. B. Lane, Beta Radiation Dosimetry for Fallout Exposure Estimates: Comparison of Theory and Experiment, SRI Project No. 7402, Stanford Research Institute, 1969.
22. P. F. Bourdeau and G. M. Woodwell, Measurements of Plant Carbon Dioxide Exchange by Infrared Absorption Under Controlled Conditions and in the Field, in *Methodology of Plant Eco-Physiology*, Proceedings of the Montpellier Symposium, pp. 283-289, UNESCO, Paris, 1965.
23. H. T. Odum and C. F. Jordan, Metabolism and Evapotranspiration of the Lower Forest in a Giant Plastic Cylinder, in *A Tropical Rain Forest: A Study of Irradiation and Ecology at El Verde, Puerto Rico*, H. T. Odum and R. F. Pigeon (Eds.), USAEC Report TID-24270, pp. I-165-I-189, U. S. Atomic Energy Commission, 1970.
24. R. Margalef, *Perspectives in Ecological Theory*, pp. 58-63, University of Chicago Press, Chicago, 1968.
25. H. T. Odum, W. McConnell, and W. Abbott, The Chlorophyll "A" of Communities, *Pub. Inst. of Marine Sci. (Univ. of Texas)*, 5: 65-96 (1959).
26. H. T. Odum, Work Circuits and Systems Stress, in *Symposium on Primary Productivity and Mineral Cycling in Natural Ecosystems*, pp. 81-138, University of Maine Press, Orono, 1967.
27. E. B. Hadley and G. M. Woodwell, Effects of Ionizing Radiation on Rates of CO₂ Exchange of Pine Seedlings, *Radiat. Res.*, 24: 650-656 (1965).
28. G. M. Woodwell, Radiation and the Patterns of Nature, USAEC Report BNL-924, Brookhaven National Laboratory, Mar. 24, 1965.
29. E. P. Odum, The Strategy of Ecosystem Development, *Science*, 164: 262-270 (1969).
30. A. Garrett, Compositional Changes of Ecosystems During Chronic Gamma Irradiation, in *Symposium on Radioecology*, Proceedings of the Second National Symposium, Ann Arbor, Mich., May 15-17, 1967, D. J. Nelson and F. C. Evans (Eds.), USAEC Report CONF-670503, pp. 99-109, AEC Division of Biology and Medicine and Ecological Society of America, March 1969.
31. S. C. Kendeigh and G. C. West, Caloric Values of Plant Seeds Eaten by Birds, *Ecology*, 46: 553-555 (1965).
32. J. E. Gunckel and A. H. Sparrow, Aberrant Growth in Plants Induced by Ionizing Radiation, in *Abnormal and Pathological Plant Growth*, Report of a Symposium, Aug. 3-5, 1953, Upton, N. Y., Brookhaven Symposia in Biology No. 6, USAEC Report BNL-258, pp. 252-279, Brookhaven National Laboratory.
33. A. C. Mellinger, Ecological Life Cycle of *Viguiera porteri*, an Endemic to Granite Outcrops of the Southeastern United States, Ph. D. Dissertation, University of North Carolina, 1971.
34. J. L. Harper, Factors Controlling Plant Numbers, in *The Biology of Weeds*, A Symposium of the British Ecological Society, J. L. Harper (Ed.), pp. 119-132, Blackwell Scientific Publications Ltd., Oxford, 1960.
35. J. L. Harper, A Darwinian Approach to Plant Ecology, *J. Appl. Ecol.*, 4: 267-290 (1967).
36. F. Skoog, The Effect of X-Irradiation on Auxin and Plant Growth, *J. Cellular Comp. Physiol.*, 7: 227-270 (1935).
37. R. Margalef, On Certain Unifying Principles of Ecology, *Amer. Natur.*, 97: 357-374 (1963).

EFFECT OF NUCLEAR WAR ON THE STRUCTURE AND FUNCTION OF NATURAL COMMUNITIES: AN APPRAISAL BASED ON EXPERIMENTS WITH GAMMA RADIATION

G. M. WOODWELL and B. R. HOLT

Biology Department, Brookhaven National Laboratory, Upton, New York

ABSTRACT

The combined effects of blast, fallout, fire, and other disturbances that might be associated with a nuclear war would involve a complex pattern of changes in natural communities which are best described as "loss of structure." The changes include a shift in the composition of the communities away from highly integrated arrays of species characteristic of evolutionarily and successional mature communities toward the generalists of the loosely integrated communities of disturbed areas. This series of changes is accompanied by a reduction in net production and frequently by a reduction in the potential of the site to support living systems. The changes, which are associated with a wide range of disturbances, are especially significant in the case of nuclear war because effects might occur over such large areas as to delay the normal processes of recovery.

Several years ago the Ecological Society of America sponsored a small symposium, the proceedings of which were published under the somewhat pretentious title "Ecological Effects of Nuclear War."¹ We are asked what can be said now, some 7 "nuclear-warless" years later, which was not said then about effects on natural communities and their significance for agriculture. The broad pattern that we recognized several years ago has not changed at all, but details have been added. We understand better now that the effects follow a general pattern of wide applicability, which gives a certain limited capacity for prediction.

The quintessence of the pattern was reported faithfully some years ago by *Punch* with specific reference to work at Brookhaven. *Punch* observed that, if you asked the man in the street what radiation would do to a forest, he would probably reply that it would kill the trees; Brookhaven scientists had confirmed this. The important observation from these studies is almost intuitive to the man in the street but is less obvious to scientists: Radiation reduces the structure of plant communities. Plants of large stature in any natural community are

eliminated at lower exposures than plants of small stature. This statement does not mean that all plants of large stature are sensitive and all plants of low stature are resistant. It means that the community shifts under irradiation from complex arrays of plants of greatly different growth forms to simplified arrays of plants whose growth forms are restricted. The reasons for the shift are still largely unexplained in any thoroughly satisfactory way. We shall review the pattern of simplification, leaving the mechanisms and details of effects on man and man-dominated systems to others.

THE STRUCTURE OF ECOSYSTEMS

The normal pattern of development of natural ecosystems is toward increasing complexity, stability, and, within certain limits, energy flux. These properties are acquired over the long term by evolution as the plants and animals of any locale achieve some degree of accommodation to one another and to the site. In such a community—a forest, a grassland, an estuary, a lake, or a coral reef—changes in populations occur very slowly; the community is “stable.” If we disturb it, we reduce its “structure” and start a series of short-term changes recognized as “succession.” Unless the disturbance lowers the potential of the site to support life, succession restores, in a matter of years or decades, an array of plants and animals similar to that destroyed. If the site is degraded, the new community will be a different, simpler one, perhaps also stable over any period of interest to man. Accompanying these changes are simultaneous changes in rates of carbon fixation, in total respiration, and in the inventory of nutrients.

Nuclear war would affect all these aspects of the ecosystem and more. We believe the effects are broadly predictable and are most easily grasped as changes in structure. It is important to remember, however, that we have no experience with acute effects extending over such large areas as might be affected by the combination of blast, fire, and radiation damage accompanying a nuclear war. This problem of scale affects all our analyses.

EFFECTS ON STRUCTURE

The pattern of change in natural communities under irradiation can hardly be better illustrated than along the radiation gradient in the Brookhaven irradiated forest (Fig. 1). This chronic radiation experiment² allows examination of both the patterns of damage and the estimates of fallout dose required to cause that damage.^{3,4} The radiation source is 9500 Ci of ^{137}Cs , and the forest has been exposed for 20 hr daily since Nov. 22, 1961. Effects range from minor or unmeasured changes at exposures below a few tenths of a roentgen to elimination of all higher plants at exposures in excess of several hundred roentgens per day. The forest is systematically dissected between these extremes;³⁻⁶ trees and their dependent biota are eliminated at the lowest



Fig. 1 Infrared photographs of the Brookhaven irradiated forest in October 1969. Living tissues are light colored. Upper left is the devastated zone at 5 m from the source (~ 1290 R/day); upper right is the sedge zone at 20 m from the source (~ 120 R/day); lower left is the shrub zone at 60 m (~ 10 R/day); and lower right is oak forest at 120 m (~ 1.7 R/day).

exposures and then high shrubs, low shrubs, and herbs, leaving at the highest exposures resistant species of mosses, lichens, algae, and fungi along with a reduced microfauna (Fig. 2). This pattern, which was established within the first year of the experiment, is repeated in the herbaceous vegetation of abandoned croplands (old fields), although these communities are very much more resistant to radiation damage than those of the forest. An equivalent change in the old-field vegetation requires 5 to 10 times as much exposure, but the physiognomic changes follow the same pattern; the erect plants are more sensitive and the prostrate plants more resistant.⁷ Moreover, the plants that are resistant are common in disturbed areas. These are often persistent, even pernicious weeds, species that survive a wide spectrum of disturbances.

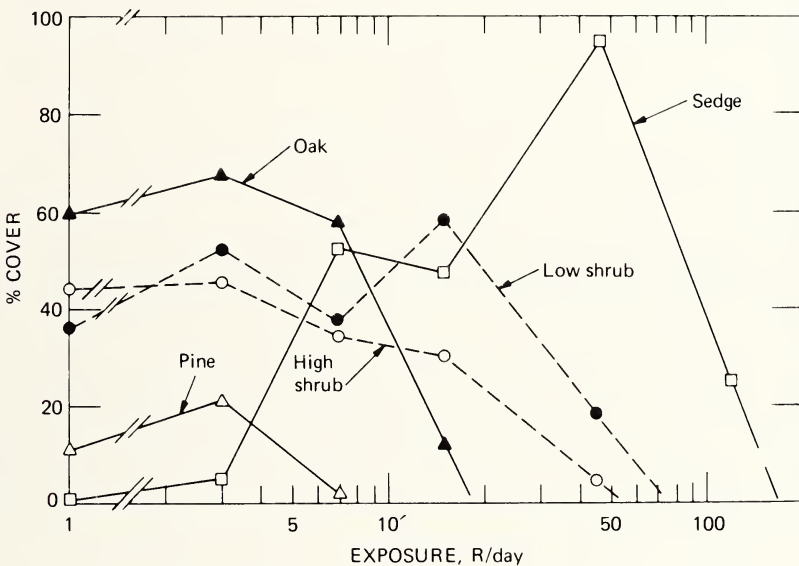

Fig. 2 Effects of 6 years of chronic gamma irradiation on cover in the irradiated forest. Cover of trees is denoted by triangles, shrubs by circles, and herbs by squares (modified from Woodwell and Whittaker¹³). The dosimetry is that of 1970, approximately 25% less than the original dosimetry of 1961.

Shifts toward plants of reduced stature occur within the cryptogam communities as well; these include the moss,⁸ lichen,⁹ algal,¹⁰ and soil fungal communities.¹¹ In an exhaustive and thoroughly detailed study of the soil fungi, the most resistant populations yet studied in the irradiated forest, Sally Gochenaour of Adelphi University, in collaboration with us,¹¹ found that the relative density of unicellular fungi rises from 3% or less at low intensities of radiation to 45% at 711 R/day and to 93% at 2570 R/day. Similarly, mycelial-forming fungi and fungi with upright conidiophores drop from a

relative density of 97% at low exposures to 3% at high exposures. Similar patterns occur along vegetation continua in Wisconsin, where the shift toward an increased percentage of structurally simple forms is associated with increasing aridity.^{1,2}

CONSEQUENCES OF SIMPLIFICATION

The implications of simplification are profound, extending as they do from questions of ecological stability, including the generation and control of pests, to net production and the factors affecting it. These are some of the largest and most difficult questions of ecology. We shall restrict our considerations to aspects of productivity, with special emphasis on the effects of radioactive fallout from nuclear war on the nutrient pools required to sustain living systems, and shall leave discussion of the stability of populations and the generation and control of pests to other occasions, not because they are unimportant, but because they require a more detailed discussion than we can offer here.

"Primary production" refers to the total amount of energy fixed by plants. Some of the energy is used immediately in respiration; the remainder, the "net production," is available to contribute to growth and to the support of animal populations, including man. Productivity is obviously related, at least grossly, to the structure of plant communities; i.e., a reduction in structure usually causes a reduction in productivity. Ionizing radiation in the Brookhaven forest has reduced productivity from about 1200 g of dry weight per square meter per year in the intact forest to 100 to 200 g/m²/year in the shrub and sedge zones and to substantially less in the cryptogam communities of the devastated zones.^{1,3}

Although the overall pattern is one of reduced productivity as successive strata are removed, certain strata exhibit enhanced productivity at intermediate levels of radiation. This is conspicuous in the herbaceous stratum of the forest and the low herb stratum of the old fields. In the irradiated forest in the zone where trees and shrubs had been killed, the cover of the sedge *Carex pensylvanica* increased more than 90-fold before it declined abruptly at higher radiation levels (Fig. 2). In the old fields greatly increased production by crabgrass (*Digitaria* species), a prostrate species, occurred in radiation-simplified communities, paralleling the pattern in the forest.

The more common relation between the complexity of ecosystems and productivity is shown by data for the field-to-forest succession at Brookhaven. Net productivity in the first years of succession in the weed fields of abandoned gardens is 200 to 400 g/m²/year and increases to about 1200 g/m²/year in the multilayered late-successional oak-pine forest 50 years old or more (Fig. 3). On soils with higher silt and clay contents, where nutrients are more readily retained in the soil and thus are available for plant use, production may exceed by a factor of two the production on sandy soils, but it rarely exceeds a few hundred grams per square meter per year until the structure of the community has

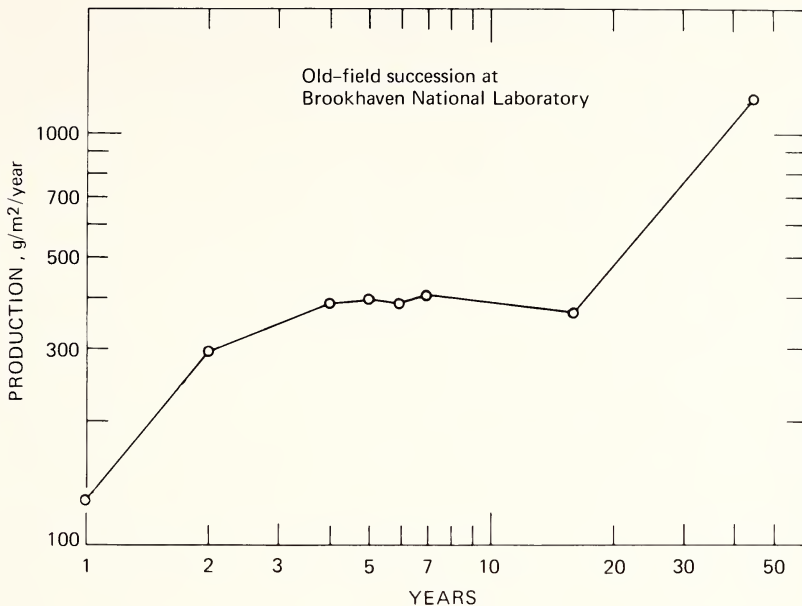

Fig. 3 Net shoot production throughout the field-to-forest succession on sandy soils in central Long Island. The terminal point is the unirradiated oak-pine forest.

developed considerably, for a period of 10 to 20 years. This would seem to be an especially significant point in considering the effects of nuclear war. The rate of recovery of natural vegetation following any disturbance is closely tied to the rate of net production. The net production of the reduced communities of the postattack landscape could be expected to be substantially less in general than the net production of the more mature communities that were destroyed. The productivity of the reduced communities would certainly be variable; it might commonly be one-half or frequently as low as one-fifth of the productivity of the mature vegetation.

More important than these relatively short-term effects would be the loss of soluble, readily leached mineral nutrients into water courses, which would cause long-term reductions in productivity of the land. Destruction of mature communities invariably results in the release of nutrients contained within the biota.¹⁴ These nutrients may be partially retained either in rapidly growing plants that follow the disturbance, as in the sedge zone of the forest, or in exchange mechanisms in the soil (Fig. 4). In soils that have low exchange capacity, as many tropical and subtropical soils do, the biota is the principal reservoir of available nutrients, and prolonged or repeated disturbance results both in release of these nutrients into water courses with consequent eutrophication of water supplies¹⁵ and in degradation of the land.¹⁶ Recovery

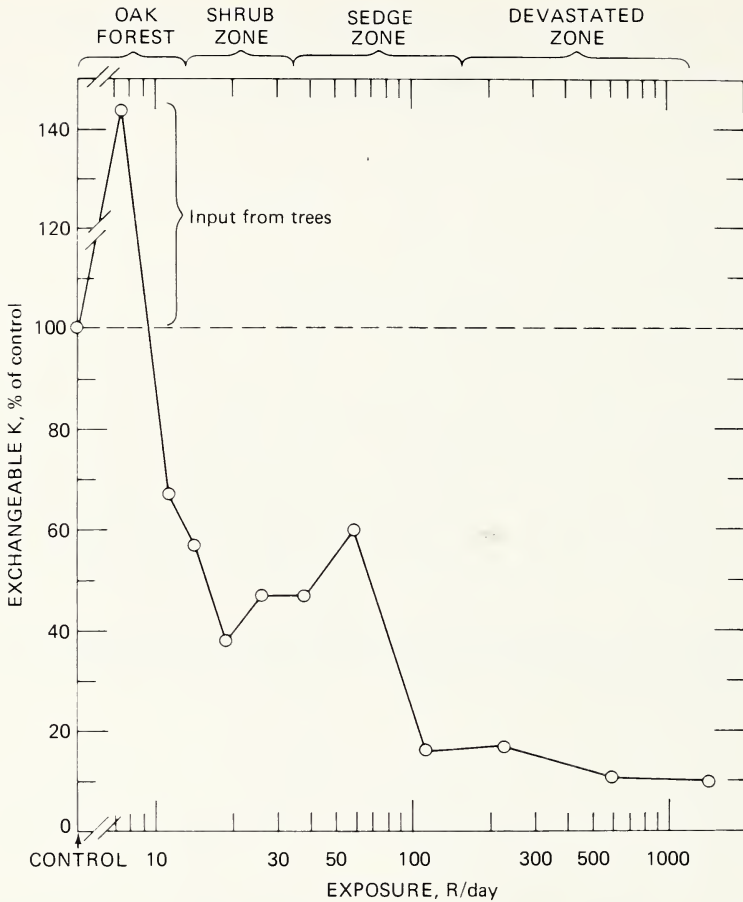

Fig. 4 Losses of biologically available potassium from the irradiated forest. Data shown are from the A_0 to A_1 soil horizon. The potassium (K) content of unirradiated vegetation equals 166% of the exchangeable potassium in the A_0 to A_1 horizons of the control forest (modified from Horrill and Woodwell¹⁹).

under these circumstances is very slow indeed. Successions on such degraded sites are marked by persistent stages of simplified communities dominated by hardy shrubs or even herbs containing substantially lower inventories of nutrients and presumably requiring less.

EFFECTS OF NUCLEAR WAR

We can state with considerable precision the broad pattern of changes in the structure and function of natural communities which a nuclear war would cause.

The radiation intensities needed to cause "severe damage" were set forth in an earlier symposium.¹ We estimated then that 4-day exposures from fallout in excess of 2000 R would result in devastation of the tree canopy and severe damage to most higher plants in coniferous forests and that exposures of 10,000 R or more would cause equivalent damage in deciduous forests.³ This change in structure involves not only reduction of the forest but also replacement of species; the shift would favor the hardy "generalists" common in disturbed areas, species that are resistant to many different types of disturbances. These are loosely integrated communities of degraded landscapes, communities of modest productivity and limited capacity to retain nutrients. The severity and duration of the changes in this direction would, of course, be a function of the severity and duration of the disturbance. If, as seems probable, radiation damage is followed by fire¹⁷ and erosion and affects large areas, say several thousand square miles, species dependent on local seed sources might well be affected, and thus recovery would be further delayed. Reestablishment of the large seeded species of late successional vegetation would be particularly slow, increasing the loss of nutrients and accentuating the tendency toward persistent simplification. The establishment of stable but depauperate communities of low productivity would be common. The effects would be greatest where rates of respiration are high and accumulations of humus low and where the exchange capacity of the soil is low. This is, of course, carried to an extreme in the wet tropics where highly leached soils are common.¹⁸ The effects are important in temperate zones, however, where losses may also be rapid and severe despite lower decay rates. Once lost, the pool of nutrients available to plants is replenished very slowly even in soils in which weatherable but unweathered minerals occur.

Animal communities are affected according to the same pattern. The complex food webs of mature ecosystems, webs which may include two or three levels of carnivory, are reduced in complexity. Disturbance and consequent reduction in energy flow results in early elimination of highly specialized carnivores. Herbivores and scavengers are favored. Within any functional group, such as predators, parasites, herbivores, decomposers, or pollinators, the generalists—species that reproduce rapidly and tolerate great variation in habitat and diet—can be expected to dominate disturbed communities.

CONCLUSIONS

The significance of these patterns to the survival of large human populations following a nuclear war is profound. Exposures to gamma radiation from fallout in excess of 2000 R in 4 days or less can be expected to devastate coniferous forests; exposures of 10,000 R would devastate most vegetation. The effects on structure of the vegetation are conspicuous, reducing it to the hardy species of disturbed landscapes. The loss of mineral nutrients from the land into water

courses, which is less obvious but no less important, would cause eutrophication and pollution of lakes, rivers, and estuaries. The land would be degraded by these losses, the extent of the degradation depending on the type of soil. In most soils a substantial fraction of the inventory of nutrients required to sustain a mature community would be lost; thus succession would be delayed or even arrested. The implications extend not only to the harvests of food and fiber from both natural and man-made ecosystems with which most of us are familiar but also to the question of pest control both within and without agriculture. Gross simplification of natural communities such as could be caused by a nuclear war would indeed open the possibility for rapid fluctuations in populations of the species that often compete with man and earn recognition as pests. We have limited experience in predicting the generation of new pests; yet we generate them regularly, and we eliminate very few. Thus, although we can define the broad picture of changes in ecosystems with some degree of precision and fidelity, the details of the pattern are still diffuse. The effects of beta radiation would only aggravate this pattern, perhaps by as much as a factor of 2 for any gamma dose. Perhaps the most important questions hinge on the size of the area affected. But there are subsidiary questions involving mechanisms and effects that are puzzling, are important to interpretation of the effects of war, and have implications for peace. These are questions about the structure of ecosystems, the stability, and the fixation and flow of energy, both the flow directly to man and into the living systems that support him indirectly. They are questions of weediness and of pests—What makes them pests? How are they controlled? These considerations of war show how little we know of the life-support systems of the planet and how much we must know soon to sustain present populations with some degree of comfort and to offer our children a world they will want.

ACKNOWLEDGMENT

This research was carried out at Brookhaven National Laboratory under the auspices of the U. S. Atomic Energy Commission.

REFERENCES

1. G. M. Woodwell (Ed.), *Ecological Effects of Nuclear War*, USAEC Report BNL-917, Brookhaven National Laboratory, August 1965.
2. G. M. Woodwell, Design of the Brookhaven Experiment on the Effects of Ionizing Radiation on a Terrestrial Ecosystem, *Radiat. Bot.*, **3**: 125–133 (1963).
3. G. M. Woodwell and A. H. Sparrow, Effects of Ionizing Radiation on Ecological Systems, in *Ecological Effects of Nuclear War*, G. M. Woodwell (Ed.), USAEC Report BNL-917, pp. 20–38, Brookhaven National Laboratory, August 1965.
4. G. M. Woodwell, Radiation and the Patterns of Nature, *Science*, **156**: 461–470 (1967).

5. G. M. Woodwell, Effects of Ionizing Radiation on Terrestrial Ecosystems, *Science*, **138**: 572–577 (1962).
6. G. M. Woodwell and A. L. Rebeck, Effects of Chronic Gamma Irradiation on the Structure and Diversity of an Oak–Pine Forest, *Ecol. Monogr.*, **37**: 53–69 (1967).
7. G. M. Woodwell and J. K. Oosting, Effects of Chronic Gamma Irradiation on the Development of Old-Field Communities, *Radiat. Bot.*, **5**: 205–222 (1965).
8. R. T. Forman and G. M. Woodwell, Effects of Chronic Gamma Irradiation on Bryophyte Populations of a Forest Ecosystem, *Bull. Ecol. Soc. Am.*, **48**: 68 (1967).
9. G. M. Woodwell and T. P. Gannutz, Effects of Chronic Gamma Irradiation on Lichen Communities of a Forest, *Amer. J. Bot.*, **54**: 1210–1215 (1967).
10. E. Franz, Effects of Chronic Gamma Irradiation on the Soil Algal Community of a Forest Ecosystem, M. S. Thesis, University of Illinois, 1970.
11. S. E. Gochenauer and G. M. Woodwell, Effects of Chronic Gamma Irradiation on the Soil Microfungi of an Oak–Pine Forest, *Amer. J. Bot.*, **57**: 746–747 (1970).
12. P. A. Orpurt and J. T. Curtis, Soil Microfungi in Relation to the Prairie Continuum in Wisconsin, *Ecology*, **38**: 628–637 (1957).
13. G. M. Woodwell and R. H. Whittaker, Effects of Chronic Gamma Irradiation on Plant Communities, *Quart. Rev. Biol.*, **43**: 42–55 (1968).
14. G. F. Likens, F. H. Bormann, N. M. Johnson, D. W. Fisher, and R. S. Pierce, Effects of Forest Cutting and Herbicide Treatment on Nutrient Budgets in the Hubbard Brook Watershed Ecosystem, *Ecol. Monogr.*, **40**: 23–47 (1970).
15. F. H. Tschirley, Defoliation in Vietnam, *Science*, **163**: 779–786 (1969).
16. P. H. Nye and D. J. Greenland, The Soil Under Shifting Cultivation, Technical Communication No. 51, Commonwealth Bureau of Soils, Harpenden, England, 1960.
17. A. Broido, Effects of Fire on Major Ecosystems, in *Ecological Effects of Nuclear War*, G. M. Woodwell (Ed.), USAEC Report BNL-917, pp. 11–19, Brookhaven National Laboratory, August 1965.
18. S. R. Eyre, *Vegetation and Soils*, Aldine Publishing Company, Chicago, 1963.
19. A. D. Horrill and G. M. Woodwell, Effects of Chronic Gamma Irradiation on the Podzolic Soil of an Oak–Pine Forest of Long Island, New York, *Ecology*, submitted.

PREDICTION OF RADIONUCLIDE CONTAMINATION OF GRASS FROM FALLOUT- PARTICLE RETENTION AND BEHAVIOR

ROGER C. DAHLMAN

Ecological Sciences Division, Oak Ridge National Laboratory, Oak Ridge, Tennessee

ABSTRACT

Retention of large (44- to 188- μ) fallout-simulant particles by dense fescue grass approached 50% initially, but, from 1 hr to 1 day later, weathering processes decreased retention to 10%. A modified negative-exponential function characterized particle weathering over a 2- to 3-week period. Half-time for early weathering loss was 3 to 4 days, but retention approached an asymptotic level after 2 to 3 weeks, at which time 2% of the ground-surface deposit remained on vegetation. Particle deposits on leaf blades were readily removed by slight wind (<1 mph) and phytotoxic movements of the foliage. Axillary deposits, however, were not readily removed by wind and rain. Using Miller's contamination factor convention ($a_L = C_p/m$) and nuclide leachability, we predicted the ^{137}Cs contamination of fescue foliage (F_L) from fallout simulant independently according to the expression $F_L = a_L W_L$.

Surface nuclear detonations produce both worldwide and local fallout materials that may be hazardous to biological organisms. Precise definition of different kinds of fallout is difficult because many variables influence formation processes and distribution patterns. The properties of local* fallout from a given detonation depend on the kind of materials drawn into the fireball, the cloud-arrival time, and the particle size distribution, which is a result of the condensation of vaporized materials and the character of initial ejecta. Rather than distinct zonation, the deposits exhibit a gradation of particle size and radioactivity properties as a function of distance from formation. The variable nature of local fallout notwithstanding, the materials deposited in the vicinity of 7- to 30-kt test shots have certain consistent characteristics.¹ Deposits of 50- to 150- μ material were recorded 50 to 140 miles from ground zero. At least 50% of

*Conceptually a local deposit is regarded as a layer of particulate material that can be seen with the unaided eye.

total fallout was in the 44- to 177- μ size class, and an appreciable quantity of the radioactivity was fixed to this fraction.

Fallout deposits from nuclear testing traditionally have been reported in terms of radiation intensity contours rather than mass loads, although the latter parameter would be more useful for the experimental determination of particle behavior and radiation exposure in specialized situations. Mass load has been estimated indirectly from mass-contour ratios, fallout specific activity, and intensity-contour ratios,^{2,3} but these parameters are often unavailable, a factor which increases the difficulty of characterizing local fallout deposit. Assuming that volcanic eruptions produce particle clouds somewhat similar to those of nuclear detonations, Miller^{4,5} and Miller and Lee⁶ evaluated the deposition characteristics downwind from the Costa Rican volcano Irazu. As much as 8 g/sq ft/day was deposited 25 miles downwind from Irazu, and 90% of the particles were in the 44- to 175- μ size class. These measurements of particle travel and mass load represent minimal magnitudes because the cloud dimensions were somewhat smaller than those recorded for 7- to 30-kt surface tests.

Accumulations of local fallout are important radiologically because subsurface biological tissues may receive a considerable beta dose from surface deposits. The meristematic regions of plant apices which reside within several millimeters of the surface will be particularly sensitive to the beta component. That biological effects to plants were manifested by beta radiation from local deposits is unclear according to field observations associated with projects Sedan, Palanquin, and Cabriole. Damage from local fallout was attributed to the physical effect of dust in the Sedan test,⁷ but plant effects at Palanquin and Cabriole⁸ were greater than would be expected from either dust deposits or cumulative gamma dose. Plants exhibited damage when the total beta dose was less than 200 rads. A mantle of dust covered the plants where effects were manifested, but mass load of the deposit was not reported.

According to a damage-assessment analysis, Brown and Pilz⁹ calculated beta-to-gamma-dose ratios of 2 to 4 for average-dimension plant meristems at 1 m height. At 1 cm height the dose ratios were 10 to 20 depending on time of arrival. However, these calculations were based on uniform deposition, which ignores the specialized cases of particle retention and concentration, e.g., collection in plant crevices, a phenomenon that has been observed frequently.^{4,10-12} The specific morphological characteristics not only affect particle concentration and dose to local tissues but also influence the magnitude of initial interception and the degree of retention as a function of time.

Despite intensive efforts to characterize initial retention of fallout ash by plants⁴⁻⁶ and long-term contamination from nuclear fallout debris,^{1,7,8,13,18} there is limited information on the behavior of fallout materials in the relatively short interval after deposition (several hours to 1 week). Additional data on retention phenomenology would be useful for estimating plant contamination and species vulnerability to beta radiation. The results of initial retention and short-term coefficients of loss for simulated-fallout deposits in a tall fescue

(*Festuca arundinacea* Shreb) meadow community are reported here. Mass load and particle diameter were consistent with the previously described requirements for local fallout in the vicinity of 7- to 30-kt nuclear tests and for reported deposition of fallout from a volcanic eruption. Evaluations for this magnitude of detonations obviously are very conservative relative to what might be expected from megaton-size explosions. Particle travel, mass load, and area coverage quite likely would be considerably different from multiple megaton-size detonations.¹

Data on retention are evaluated according to Miller's⁵ contamination-factor model to show correlation between predicted and observed vegetation contamination from local fallout. Relations of retention weathering and intraplant radiocesium movement are summarized and modeled to provide a means for estimating potential source terms that can be used as input for the vegetation-man food chain.

PROCEDURES

Experimental Area

Extraneous plant material (litter and weeds) was removed from a 4-year-old stand of tall fescue 6 weeks before a fallout simulant was applied to the vegetation. A homogeneous cover of fescue grass developed by late July, at which time the plant density* was $17.4 \text{ g/sq ft} \pm 2.3$ (standard error), and average canopy height was 30 cm. Two areas (each 2.5 by 5 m), with a 1-m wide border zone extending around each plot, were located for treatment. Walkways were established in this zone to avoid disturbing the contaminated plants during later sample collection. When the experiment was terminated after 3 weeks, plant density was $20.2 \pm 1.9 \text{ g/sq ft}$, and the quantity of grass for intermediate dates of sampling was estimated by interpolation. Meteorological data (temperature, rainfall, dew point, wind velocity, and direction) were recorded continuously at a nearby (200 m distant) weather station.

Simulant Characteristics and Application

A fallout simulant was fabricated at the Stanford Research Institute by fixing low-level ⁸⁶Rb on two size classes of quartz sand. The simulant possessed physical characteristics similar to local fallout,^{1,5-17} and the ⁸⁶Rb label expedited the measurement of sand retention and loss by the grass. Rubidium-86 was used because its half-life (18.7 days) and gamma emission (1.07 MeV) were convenient for following short-term particle movement on vegetation. Minimal occupational exposure and field-site contamination hazards resulted from the

*Plant density is expressed in terms of dry weight per area rather than in conventional terms of units of individuals per area.

use of this isotope. Leachability was low (2% over 24 hr at a particle-to-water ratio of 1 to 100) because high temperatures during fabrication fused the isotope to the quartz. Two particle size classes (44 to 88 and 88 to 177 μ in diameter*) were used in the experiment to determine differential retention and loss parameters for both fine and coarse fractions associated with local fallout debris. At the time of simulant application, the ^{86}Rb activity density was 1.56 and 2.07 $\mu\text{Ci/g}$ for fine and coarse particles, respectively.

The simulant was released from a hopper-spreader apparatus that traveled on elevated girders at least 1 m above the vegetation canopy. At this height the particles approached maximum falling velocity before contact with the canopy. Rate of travel and simulant release were controlled remotely to minimize hazard to personnel during application. Uniformity and effectiveness of simulant application from such an apparatus have been reported elsewhere.^{10,12} Two separate areas were contaminated with fine and coarse simulant particles during calm conditions in late afternoon. Ambient temperature averaged $89 \pm 1^\circ\text{F}$ and relative humidity was $78 \pm 0.8\%$ in the plant canopy.

Sampling and Radioassay

Particle mass load on an area basis was determined gravimetrically from randomly positioned plate collectors placed above the canopy. Similar plates were placed beneath the grass canopy, and initial grass retention at t_0 was determined by difference. Collecting dishes from beneath the canopy were recovered immediately after application, before weathering and redistribution of intercepted particles could occur.

Short- and long-term particle-retention characteristics were determined by radioassay of randomly collected subsamples of grass. To minimize accidental particle loss during the sampling procedure, we placed a plastic bag gently over small clusters of tillers and gathered it tightly around the tussock base before the plants were clipped. Ten replications were taken from each area at the respective sampling dates. The samples, still inside the plastic collection bags, were placed in uniform geometry cartons and assayed with a 3- by 3-in. crystal and Packard MCA-115. Only the 1.07-MeV gamma peak of the radiation spectrum was evaluated in the radioanalysis. Counting efficiency and physical decay were determined from a 1.05- μCi ^{86}Rb standard of similar geometry which was obtained independently from the Oak Ridge National Laboratory (ORNL) Isotopes Division.

*Hereafter, the 44- to 88- μ and 88- to 177- μ size classes are designated as fine and coarse particles, respectively.

RESULTS AND DISCUSSION

Mass Deposit and Initial Retention

The initial mass deposit of particles over open ground area was 11.0 ± 0.5 and 9.2 ± 1.0 g/sq ft for fine and coarse particle, respectively. This mass load approximates the quantity of surface deposit which could be expected in the form of local fallout for intermediate weapon yield according to predictions from mass-contour models¹ and measurements of volcanic ash debris.⁶ Initial retention at t_0 , as determined by difference of particle deposit above and below the grass canopy, is given as 5.0 and 1.8 g/sq ft (Table 1) for the fine and coarse size classes, respectively. A substantial fraction (45% fine and 20% coarse) was retained in the grass canopy during this short time interval, but the quantity had diminished by a factor of 3 for both size classes 1 hr later (Table 1).

These data indicate substantial particle loss from vegetation shortly after contamination, and the timing of the first observation greatly influences the magnitude of initial retention values. Nearly 50% retention has been observed here (Table 1) and elsewhere¹¹ when measurements are made immediately after deposition. However, approximately 10% retention on grass has been reported when measurement is delayed 1 hr to 1 day after deposition. Specific examples are 11% for fescue at 1 hr (Table 1), 9% for sorghum at 12 hr (fine particles¹²), and 11% average for primary volcanic deposit on Costa Rican grasses.⁶ Operationally, it seems advisable to distinguish between absolute t_0 and delayed retention (1 to 12 hr postcontamination). Herein, initial retention and/or weathering are designated as the phenomena occurring from absolute t_0 to 1 hr and effective retention as that occurring from 1 hr to several weeks.

Retention data of different size-class particles (Table 1) are based on slightly dissimilar simulant-application rates, 11.0 vs. 9.2 g/sq ft for fine and coarse material, respectively. Strict comparison of absolute retention would require adjustment of one set of data (e.g., the coarse-size-class values $\times 11.0/9.2$), thereby increasing coarse retention by 20%. Average retention (Table 1, column 12) would increase by less than 6%. This adjustment was not made, however, because the effect on subsequent evaluations of relative retention would be negligible.

Continuous Weathering Function

A continuous weathering function is an important parameter used in generalized mathematical models of landscape contamination.^{18,19} Although often an oversimplification of retention phenomenology, such functions describe the transitory foodstuff contamination and potential radiation hazard in extensive agricultural systems. For the 17-day interval, the best fit of the composite fescue data was to a negative-exponential model (Fig. 1a) of the form

$$Y = \alpha + (1 - \alpha)e^{-\lambda t} \quad (1)$$

Table 1
 MASS, ⁸⁶Rb ACTIVITY, AND SAND RETENTION BY FESCUE FOLLOWING CONTAMINATION WITH
 FINE AND COARSE FALLOUT SIMULANT

Time, days	Fescue mass,* g/sq ft†	Fine particles (44 to 88 μ)			Coarse particles (88 to 177 μ)			Average retention‡		Cumulative precipitation, in.
		⁸⁶ Rb activity μCi/g†	Retention g/sq ft	%	⁸⁶ Rb activity μCi/g†	Retention g/sq ft	%	g/sq ft§	%	
0.0	17.4 ± 2.3		5.0	45.4		1.8	19.6	3.4	33.7	0.0
0.042 (1 hr)	17.4 ± 2.3	0.153 ± 0.013	2.65	15.4	0.071 ± 0.006	1.24	6.5	1.15	11.4	0.0
0.75 (17.5)		0.117 ± 0.022	2.05	12.3	0.069 ± 0.005	1.21	6.6	0.98	9.7	0.0
1.83 (17.7)		0.062 ± 0.008	1.10	6.8	0.061 ± 0.006	1.08	6.1	0.66	6.5	0.53
2.88 (17.9)		0.074 ± 0.006	1.32	8.5	0.037 ± 0.002	0.67	3.9	0.65	6.4	0.80
5.85 (18.3)		0.018 ± 0.002	0.34	2.4	0.030 ± 0.001	0.55	3.6	0.30	3.0	1.03
6.88 (18.5)		0.015 ± 0.001	0.28	2.1	0.025 ± 0.001	0.46	3.2	0.26	2.6	1.03
17.0 (20.2 ± 1.9)		0.009 ± 0.001	0.18	2.0	0.010 ± 0.0007	0.21	2.1	0.20	2.0	2.42

* Oven-dry weight. Initial and final quantities measured. Intermediate quantities (in parentheses) estimated by interpolation.

† Plus or minus 1 standard error of mean.

‡ Average retention includes data for both fine- and coarse-particle fractions.

§ Unadjusted average of columns 5 and 9.

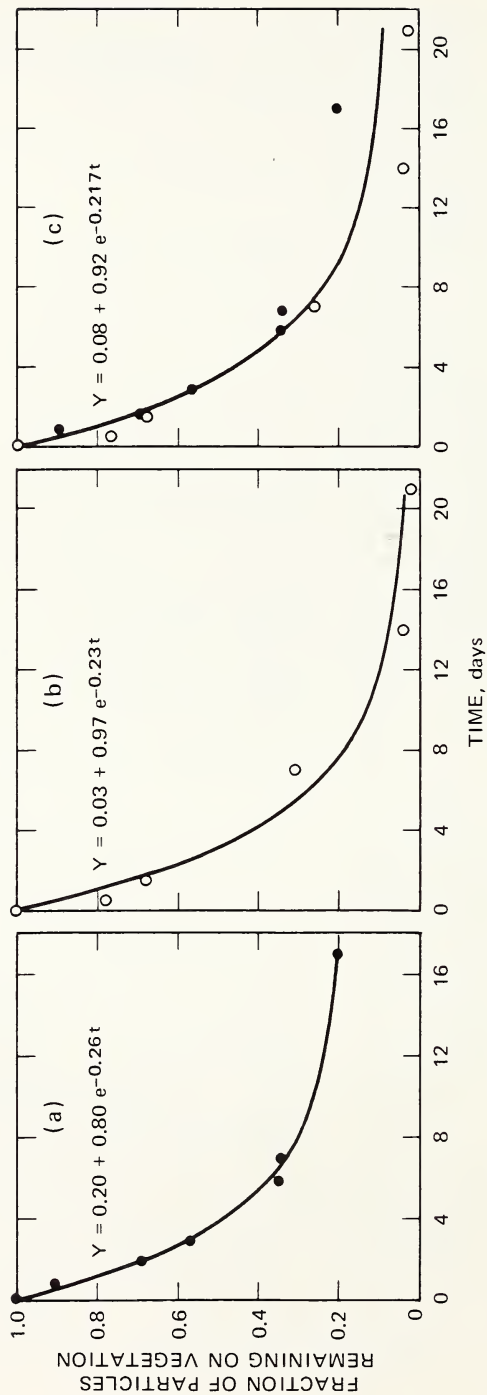

Fig. 1. Average effective particle retention by fescue (●) and sorghum (○) grasses. Data are normalized to express $t + 1$ hr as initial retention. (Sorghum data provided by Witherspoon.²⁰)

In effect, the α parameter is a weighting function that dominates the expression of retention during the early period of weathering (small t values) but exerts less influence as time passes (large t values). High α values portray considerable deviation from the normal negative-exponential model ($y = ae^{-\lambda t}$) and indicate multicomponent weathering processes, the individual components of which are discussed in the next section. Other retention data on sorghum²⁰ are also fitted to the same model (Fig. 1b), and the α and λ parameters for fescue, sorghum, and composite grass are given in Table 2. Relatively low standard errors for the α and λ parameters indicate that the continuous-function model adequately

Table 2

COMPARISON OF α AND λ PARAMETERS FOR DIFFERENT SETS OF DATA BY THE CONTINUOUS-FUNCTION WEATHERING MODEL (EQ. 1), NEGATIVE-EXPONENTIAL PARTICLE RETENTION

Test data	α^*	λ^*
Fescue	0.195 \pm 0.02	0.261 \pm 0.02
Sorghum†	0.029 \pm 0.07	0.227 \pm 0.06
Composite grass	0.081 \pm 0.05	0.217 \pm 0.03

*Plus or minus standard error of the parameter estimates.

†Sorghum data from Witherspoon.²⁰

describes partial retention for fescue grass. Higher standard errors for sorghum and composite grass reflect a less satisfactory fit of the model to the data. High variance of the parameter indicates that a zero value could be expected within the limits of error of the estimate; thus for these cases the best fit deviates little from an unmodified negative-exponential model. The λ parameters, however, were less variable in all test cases. Since the λ values are similar for different species of grass and the α parameters appear to be species dependent, the generalized model (Eq. 1) could be applied in the widespread evaluations of particulate-fallout retention on grass if an experimentally determined array of α values could be provided as input data for vulnerability assessments. In addition, if different species-related α and λ parameters were used, the model could also describe the time-dependent retention phenomena for vegetation types other than grass.

Inclusion of a constant term (α) in the weathering function implies that particle retention will never reach zero, especially over an interval of at least several months. Therefore, in the long-term contamination assessments, it may be necessary to use two negative-exponential functions, the early component being governed by a 3 to 4 day half-time retention (Fig. 1) and the later component (post 1 week) being characterized by a longer half-time retention.

Perhaps the frequently used 14-day half-time value would be meaningful for the long-term component.

Multicomponent Weathering

Component loss of fallout particles from plants is evaluated when there is reason to believe that several factors independently influence retention. For

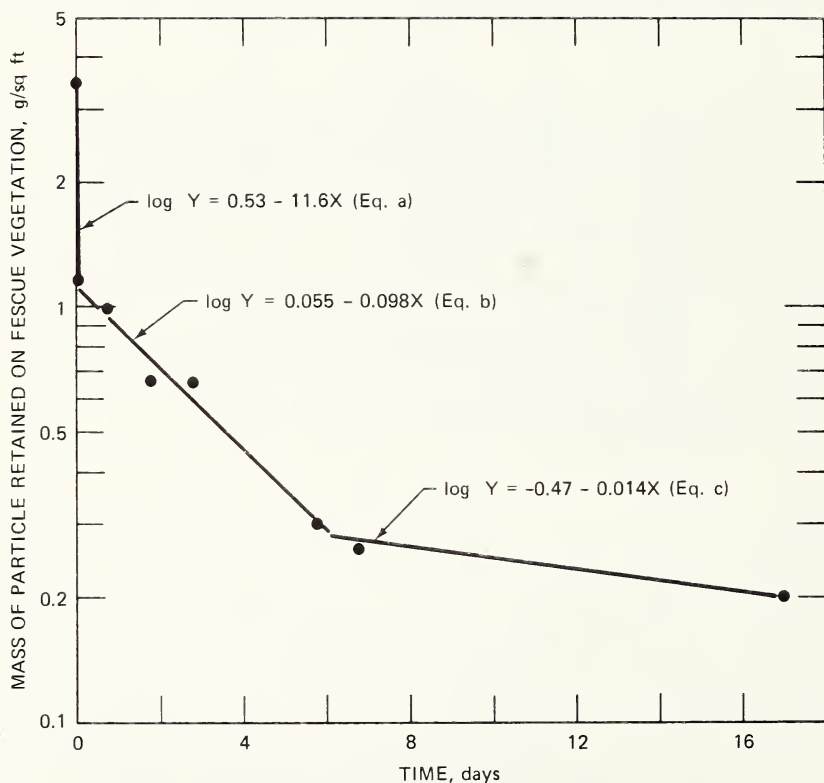

Fig. 2 Log-normal regression equations describing component particle retention by fescue.

example, weathering of particles from grass plants for initial particle retention on leaf-blade surfaces is different from that for retention in axillary crevices. Although the exact details of independent weathering processes are not well understood, several distinct components are evident for the fescue data (Fig. 2). When the data were fitted to a semilogarithmic regression model of the form

$$\log Y = a + bX \quad (2)$$

two log normal equations (Fig. 2, Eqs. b and c) described effective retention for days 0 to 6 (in practice here, the $t + 1$ hr value is considered day 0) and days 6 to 17. The low-rate coefficients (b) were 0.098 and 0.014 for early and late time intervals, respectively. The difference of a factor of 7 in the loss rate for early and late intervals strongly indicates that dissimilar mechanisms affect retention on fescue and sorghum. No outwardly apparent effects were caused by moderate rainfall and low wind velocity; thus particle retention is influenced by a complex of environmental and vegetative factors that presently are poorly understood.

Extremely rapid weathering during the first hour (3.4 to 1.2 g/sq ft, Fig. 2) characterized the initial component of loss. Described in log-normal terms, the loss-rate parameter (Fig. 2, Eq. a) was 11.6, a value two to three orders of magnitude greater than the loss-rate values derived for effective retention. However, one should place only limited confidence in this parameter of the initial weathering interval since the function is described from merely two data points.

In terms of potential radiation damage to plants from local fallout, one can expect extremely rapid weathering of the early arriving, highly radioactive, but promptly decaying products. Rapid exponential loss of particles, coupled with the substantial early radioactive decay, would minimize the contact beta dose to sensitive plant parts. Approximately 10% of the fallout, however, may be effectively retained 1 hr postdeposition; and the loss rate of this fraction diminishes more slowly throughout a several-week period, thereby allowing appreciable beta exposure to plant parts in direct contact with the particles.

Differential particle weathering can be attributed to the combined effects of meteorological factors (wind, rain), leaf morphology (pubescence), and plant habit (crevice, niche). Wind-induced weathering was considered nominal in this experiment because of atmospheric calms during application and because wind speeds in the grass canopy (at a height of 20 cm) were very low during the 17-day period. Wind speeds ranged from 0 to 1.5 mph and averaged 0.3 mph based on extrapolations from wind-profile data obtained 10 cm above the vegetation.

The low-magnitude wind speeds probably were effective in the initial dislodgement of particles from horizontally positioned leaf blades immediately following interception. Thereafter wind-induced weathering was negligible because particles had become trapped in the axillary crevices of the grass shoot. Neither were loss rates affected appreciably by moderate quantities of rainfall occurring as light showers. One-inch cumulative precipitation over days 2 to 4 caused no significant deviation from the established trend of particle loss for the composite data (Fig. 2). An additional 1.4-in. steady rainfall at day 12, the midregion of the slow-loss component, did not enhance particle removal.

Vegetation Influence

Long-term retention of fallout particles is strongly influenced by plant-habit and leaf-surface features.^{4,12,13} The junction of blade and sheath in grasses is a particularly effective collector¹⁰ because the V-shaped leaf-blade structure channels particles into the crevice between sheath and stem. Rainfall and wind-induced flexing movements further impact the particles within the sheath. The principal mode of removal is associated with growth and development of internal leaf tissue whereby adhering particles are carried upward by the elongating central axis. It follows, then, that particle retention would be directly related to growth, perhaps as a mirror image of the generalized exponential growth function. Retention results (Fig. 1) indeed suggest such a negative-exponential loss rate for particle losses not conspicuously related to moderate meteorological events. Although central-axis growth rate was not measured in the present study, perhaps in future retention experiments it would be advisable to examine the correlation between central-axis elongation and fallout-particle decontamination, especially for maize and cereal-grain crops.

Contamination-Factor Analysis

Data on particle retention (Table 1) allow the calculation of contamination factors, as derived by Martin¹⁴ and Miller,⁵ for successive intervals after contamination. Particle mass load (m) and foliar retention (C_p) from Table 3 were determined experimentally, and contamination factors (a_L) were calculated according to the relation

$$a_L = C_p^0/m \quad (3)$$

This expression allows an estimation of time-dependent vegetation contamination in future situations based on knowledge of plant density and soil-surface fallout deposits and assuming that the affected plant communities exhibit similar retention characteristics. For a single fallout deposit, then, maximum retention and contamination factors are observed at t_0 and decrease thereafter (Table 3). Retention at $t + 1$ hr is taken as t_0 , and the a_L factors for fescue were 0.009 and 0.004 for fine and coarse materials, respectively. Within 2 days the values had decreased by a factor of 2 and at $t + 1$ week by a factor of 4, but they changed very little during the second week of the field observation. Effective weathering had occurred within 1 week; thereafter the slower particle loss rate predominated.

The contamination-factor expression originally was derived in connection with project Sedan and later was applied to volcanic fallout deposits around volcano Irazu in Costa Rica. Miller and Lee⁶ reported retention values and determined a_L factors (Table 3) for Costa Rican grasses which compare favorably with those reported here. The a_L factors herein derived for tall fescue

Table 3
 FESCUE FOLIAR-RETENTION (C_p) AND CONTAMINATION-FACTOR (a_L) PARAMETERS ALONG WITH
 GENIZA-ARENA-ASH CONTAMINATION FACTORS FOR COMPARISON

Time, days	Fescue retention and contamination factors						Geniza-Arena-ash contamination factors and exposure conditions ⁶	
	Fine particles			Coarse particles			a_L , sq ft/g	Deposition conditions ⁶
	Effective retention, g/sq ft	C_p ,* g/g	a_L ,† sq ft/g	Effective retention, g/sq ft	C_p ,* g/g	a_L ,† sq ft/g		
0.042 (1 hr)	1.7	0.098	0.0089	0.60	0.034	0.0037	§	
0.75	1.35	0.77	0.0070	0.61	0.035	0.0038	0.001 0.05 to 0.1 0.07 to 0.002	Dry, P Wet, S Dry, S
1.83	0.75	0.042	0.0038	0.56	0.032	0.0035	0.05	Damp, P
2.88	0.94	0.052	0.0047	0.36	0.020	0.0022	0.015	3-in. rain with recurring deposition
5.85	0.27	0.015	0.0014	0.33	0.018	0.0020	§	
6.88	0.23	0.012	0.0011	0.29	0.016	0.0017		
17.0	0.22	0.011	0.0010	0.19	0.009	0.0010	0.003 to 0.005	3.5-in. rain with recurring deposition

* C_p is grams of particles per gram of foliage.
 † a_L is C_p/m , where m is 1.0 ± 0.5 and 9.2 ± 1.0 g/sq ft for fine and coarse deposits, respectively.
 ‡ Variable fallout deposition is designated as P, short-period unweathered deposit, and S, multiple, long period, weathered deposit.
 § No comparable data.

ranged from 0.004 to 0.007 at days 1 and 2 under dry conditions (80% relative humidity and no wind). The Ceniza-Arena a_L factors derived by Miller and Lee for an equivalent period ranged from 0.001 to 0.07 for dry conditions and from 0.05 to 0.1 for wet conditions. Good agreement obviously exists among the results from the two different assessments of foliar retention and for the calculated contamination factors irrespective of initial mode of fallout deposition. It seems that dense vegetation in subhumid or humid climates demonstrates similar patterns of early retention.

It is likely that total radionuclide transfer to plant parts would be greatly influenced by fallout-particle distribution in the canopy. In a subhumid environment, however, plant structures can assimilate much of the nuclide that is leached from fallout materials and transferred to plant surfaces. This argument is verified by using the derived a_L for coarse particles (0.0039) to predict ^{137}Cs contamination of fescue for the 10- by 10-m plots tagged in August 1967, in which a prediction of grass contamination is compared with an independent observation of radiocesium assimilation by the fescue community.¹⁰ The fraction retained by the vegetation canopy is estimated from Miller's plant-retention relation:

$$F_L = a_L w_L \quad (4)$$

when a_L is 0.004 and w_L is 65 g/sq ft, the plant density at the time of contamination. F_L is 0.254, which, when multiplied by the activity-application rate (2.06 mCi/sq ft), is the total ^{137}Cs contamination of foliage [i.e., $F_L = 2.06 \times 0.254 = 0.523$ mCi/sq ft (expressed in terms of activity content of vegetation)]. It was observed from laboratory tests that 15% of the radiocesium will leach from the particle in an aqueous system. If the leachate is assimilated directly by vegetation, then, $0.523 \text{ mCi/sq ft} \times 0.15 = 78 \mu\text{Ci/sq ft}$ is the activity of vegetation shortly after contamination. The observed radiocesium content of vegetation¹⁰ at $t + 8$ days was $78 \mu\text{Ci/sq ft}$, showing a remarkably good agreement between that predicted from contamination-factor parameters and that measured after the contamination event. It can therefore be concluded from this analysis of a field test that foliar contamination-factor expression coupled with fallout leachability provides a good estimation of vegetation contamination in a grass community.

Source-Term Evaluation Model

Estimation of radiological hazards, from either direct particle deposit or nuclide assimilation, depends on identification of a source term or entry of the contaminant into the food chain. At least four different source terms (Fig. 3; compartments P, E, I, and F) can serve as the initial input for the grass-cow-man food chain. Dissimilar contamination phenomena and contaminant behavior patterns are manifest for each source term. Short-term hazards

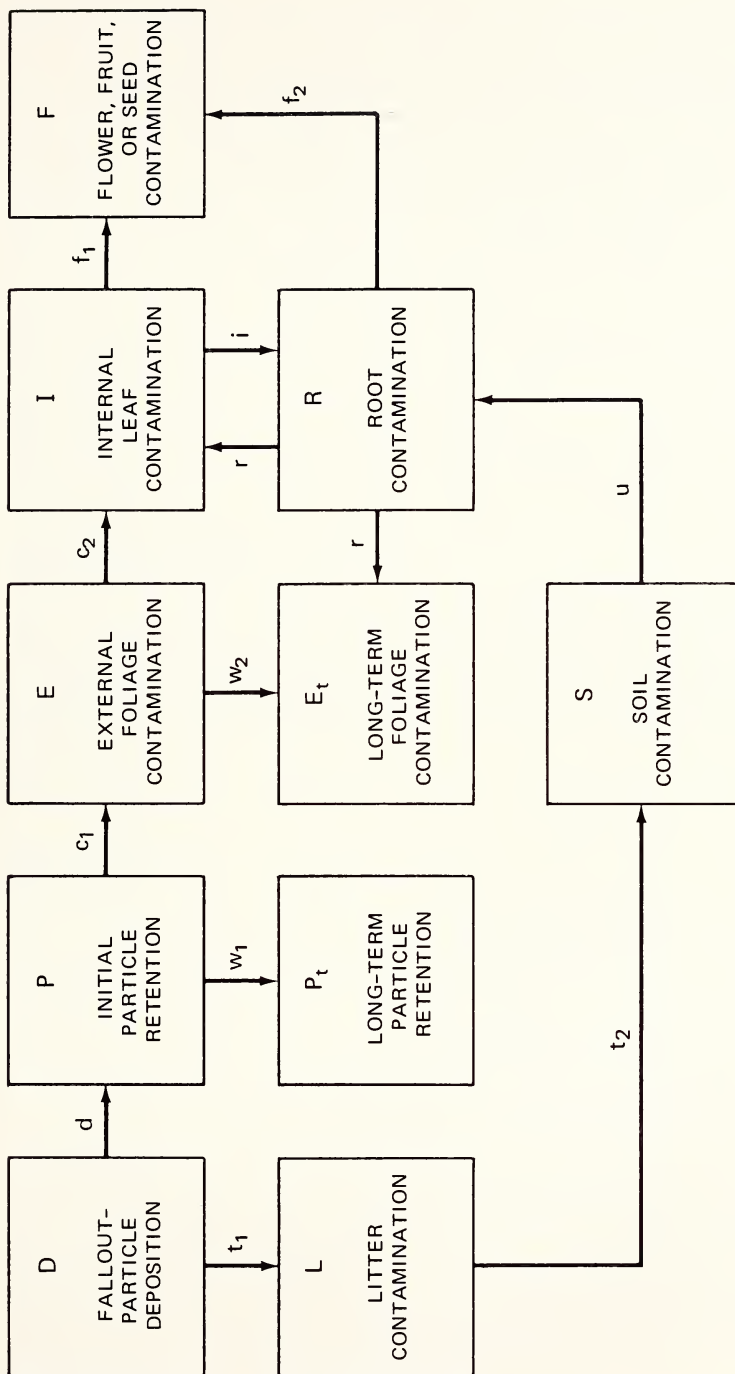

Fig. 3 Source-term relations of fescue grass after contamination with fallout-simulant particles. Transfer coefficients are evaluated in Table 4.

Table 4
TRANSFER FUNCTIONS FOR SOURCE-TERM EVALUATION MODEL

Transfer functions	Definitions	Values for fescue grass	Source
d	= f(m), initial fraction of fallout mass load	0.10	Experimental
t ₁	= 1-d	0.90	Calculated
t ₂	= f(L), fraction moving from litter to soil	0.01	Inferred from litter decomposition rate (Koelling and Kucera ^{2,3})
w ₁	= Particle weathering function = 1-P where $P = \alpha + (1-\alpha)e^{-\lambda t}$	$\alpha = 0.2$ $\lambda = 0.26$	Regression of particle retention on time
c ₁	= f(P), fraction of nuclide movement from particle to foliage	0.15	Measured aqueous leachability
w ₂	Nuclide weathering function = 1-E where $E = \alpha + \beta e^{-\lambda t}$	$\alpha = 0.27$ $B = 1.59$ $\lambda = 0.052$	Regression of nuclide retention on time
c ₂	= f(E), fraction of nuclide movement from external to internal plant parts	0.10	Inferred from Levi ^{2,1} (bean plants)
i	= f(I), fraction of internally assimilated nuclide movement to roots	0.25	Experimental
r	= f(R), fraction of root contaminant moving to current season's growth	0.4	Assumption
f ₁	= f(I), fraction of leaf nuclide moving to seed	0.1	Inferred from Levi ^{2,1} (bean plants)
f ₂	= f(R), fraction of root nuclide moving to seed	0.1	Assumption
u	= f(S), fraction of soil nuclide taken up by plant	0.001	Inferred from Nishita et al. ^{2,2}

would be related to particle deposition and retention on foliage, whereas long-term problems could derive from assimilation and equilibration of the nuclide in the plant community. The model couples interrelations among principal source terms in order to estimate contamination potentials as a function of time, particle behavior, and intraplant nuclide movements. Transfer and weathering functions (Table 4) are used to predict the fate of radiocesium applied in the form of fallout-simulant particles to a fescue meadow. For subhumid environments, importance of the source term proceeds in Fig. 3 from left to right (compartments P to I) according to the approximate time sequence: P, 1 to 10 days; E, 7 to 100 days; I, 3 months to several years; F, any time interval prior to seed production. In practice, the model will predict the character and extent of contamination at successive intervals after fallout deposition. Knowledge of deposition forms, fallout behavior, and source-term magnitudes will foster more-intelligent decisions concerning grazing of pastures in the event of widespread contamination from nuclear explosions.

ACKNOWLEDGMENTS

This research was sponsored by the U. S. Atomic Energy Commission and the Office of Civil Defense under contract with the Union Carbide Corporation.

The assistance of John Beauchamp of the ORNL Mathematics Division in derivating the negative exponential regression equations is gratefully acknowledged.

REFERENCES

1. L. Baumash, J. W. Neel, W. K. Vance III, H. K. Mork, and K. H. Larson, Distribution and Characterization of Fallout and Airborne Activity from 10 to 160 Miles from Ground Zero, Spring, 1955, USAEC Report WT-1178, University of California, Los Angeles, September 1958.
2. D. E. Clark, Jr., and W. C. Cobbin, Some Relationships Among Particle Size, Mass Level, and Radiation Intensity of Fallout from a Land Surface Nuclear Detonation, Report USNRDL-TR-639, Naval Radiological Defense Laboratory, Mar. 21, 1963.
3. C. F. Miller and Oliver S. Yu, The Mass Contour Ratio for Fallout and Fallout Specific Activity for Shot Small Boy. Final Report, SRI Project MU-6358, Stanford Research Institute, 1967.
4. C. F. Miller, Operation Ceniza-Arena: The Retention of Fallout Particles from Volcano Irazu (Costa Rica) by Plants and People. Part II, Appendices, SRI Project MU-4890, Stanford Research Institute, 1966.
5. C. F. Miller, The Retention by Foliage of Silicate Particles Ejected from the Volcano Irazu in Costa Rica, *Radioecological Concentration Processes*, B. Aberg and F. P. Hungate (Eds.), Proceedings of an International Symposium, Stockholm, Apr. 25-29, 1966, pp. 501-526, Pergamon Press, Inc., New York, 1967.

6. C. F. Miller and H. Lee, Operation Ceniza-Arena: The Retention of Fallout Particles from Volcano Irazu (Costa Rica) by Plants and People. Part I, Report AD-637313 (SRI Report No. MU-4890), Stanford Research Institute, January 1966.
7. Janice C. Beatley, Effects of Radioactive and Nonradioactive Dust upon *Larrea divaricata* Cav., Nevada Test Site, *Health Phys.*, **11**: 1621–1624 (1965).
8. W. A. Rhoads, R. B. Platt, R. A. Harvey, and E. M. Romney, Ecological and Environmental Effects from Local Fallout from Cabriole. I. Radiation Doses and Short-Term Effects on the Vegetation from Close-In Fallout, USAEC Report PNE-956, University of California, Los Angeles, Aug. 23, 1968.
9. S. L. Brown and U. F. Pilz, U. S. Agriculture: Potential Vulnerabilities. Final Report, SRI Project MU-6250-052, Stanford Research Institute, 1969.
10. R. C. Dahlman, S. I. Auerbach, and P. B. Dunaway, Behavior of ^{137}Cs Tagged Particles in a Fescue Meadow, *Environmental Contamination by Radioactive Materials*, Seminar Proceedings, Vienna, Mar. 24–28, 1969, pp. 153–165, International Atomic Energy Agency, Vienna, 1969 (STI/PUB/226).
11. J. E. Johnson and A. I. Lovaas, Deposition and Retention of Simulated Near-In Fallout by Food Crops and Livestock, Progress Report No. DAHC 20-68-C-0120, Colorado State University, 1969.
12. J. P. Witherspoon and F. G. Taylor, Jr., Interception and Retention of a Simulated Fallout by Agricultural Plants, *Health Phys.*, **19**: 493–499 (1970).
13. E. M. Romney, R. G. Lindberg, H. A. Hawthorne, B. G. Bystrom, and K. H. Larson, Contamination of Plant Foliage with Radioactive Fallout, *Ecology*, **44**: 343 (1963).
14. W. E. Martin, Early Food-Chain Kinetics of Radionuclides Following Close-In Fallout from a Single Nuclear Detonation, in *Radioactive Fallout from Nuclear Weapons Tests*, Germantown, Md., Nov. 3–6, 1964, A. W. Klement (Ed.), pp. 758–782, AEC Symposium Series, No. 5 (CONF-765), 1965.
15. W. B. Lane, Fallout Simulant Development: The Sorption Reactions of Cerium, Cesium, Ruthenium, Strontium, and Zirconium–Niobium, Report AD-635547 (SRI-MU-5068), Stanford Research Institute, November 1965.
16. W. B. Lane, Fallout Simulant Development: Temperature Effects on the Sorption Reactions of Strontium on Feldspar, Clay, and Quartz, Report SRI-MU-6503, Stanford Research Institute, 1968.
17. W. B. Lane, Fallout Simulant Development: (1) Synthetic Fallout Facilities at Camp Parks, and (2) Two-year Leaching of Cesium from Synthetic Fallout and Fission Products from Shasta Fallout, Report SRI-MU-7236, Stanford Research Institute, 1969.
18. C. F. Miller and P. D. LaRiviere, Introduction to Long-Term Biological Effects of Nuclear War, USAEC file No. NP-16462 (SRI-MI-5779), Stanford Research Institute, April 1966.
19. W. E. Martin and F. B. Turner, Transfer of ^{89}Sr from Plants to Rabbits in a Fallout Field, *Health Phys.*, **12**: 621–631 (1966).
20. J. P. Witherspoon, Particle Retention by Sorghum, Oak Ridge National Laboratory, personal communication, 1970.
21. E. Levi, Uptake and Distribution of ^{134}Cs Applied to Leaves of Bean Plants, *Radiat. Bot.*, **6**: 567–574 (1966).
22. H. Nishita, E. M. Romney, and K. H. Larson, Uptake of Radioactive Fission Products by Plants, *Radioactive Fallout, Soils, Plants, Foods, Man*, E. B. Fowler (Ed.), American Elsevier Publishing Company, Inc., New York, 1965.
23. M. R. Koelling and C. L. Kucera, Dry Matter Losses and Mineral Leaching in Bluestem Standing Crop and Litter, *Ecology*, **46**: 529–532 (1965).

RESPONSES OF SOME GRASSLAND ARTHROPODS TO IONIZING RADIATION

CLARENCE E. STYRON* and GLADYS J. DODSON

Ecological Sciences Division, Oak Ridge National Laboratory, Oak Ridge, Tennessee

ABSTRACT

Responses of arthropod communities to ionizing radiation and the interactions of radiation with other environmental parameters are being investigated in (1) studies of biological and physical dosimetry of beta and gamma radiation from simulated fallout in a grassland area, (2) long-term field observations on interactions of the fallout radiation with seasonal changes in composition and structure of the arthropod community, and (3) short-term laboratory studies on interactions of fallout radiation with population dynamics of selected insect species. Beta- and gamma-radiation levels in the simulated fallout area were determined by the thermoluminescent dosimetry. Lithium fluoride microdosimeters attached to grasshoppers and crickets in the fallout field indicated that these closely related organisms received significantly different radiation doses owing to differences in habitat. Numbers of soil-, litter-, and grass-inhabiting arthropods collected in the simulated-radioactive-fallout field varied significantly among months and taxa. There was no significant difference in variation between arthropod communities of field enclosures before application of the simulant. The only significant differences among numbers of individuals in taxa comprising the arthropod communities of control and contaminated areas occurred 4 months after contamination. No significant increase in species composition dissimilarity between the contaminated and control areas appeared during the second year following application of the fallout. Consequently the threshold for effects of fallout radiation on species composition of the arthropod community must be above the ~ 13 rads/day delivered over this time. Data on exposure of laboratory populations of *Folsomia* (Collembola) to beta radiation from ^{90}Sr - ^{90}Y fallout indicate that population dynamics were affected primarily by sensitivity of fertility rates rather than by sensitivity of adults. Dose rates estimated to give an $\text{LD}_{50/30}$ or $\text{LD}_{50/60}$ for adults were more than twice as high as dose rates required to reduce fertility rates to zero.

*Present address: Division of Mathematics and Natural Science, St. Andrews Presbyterian College, Laurinburg, North Carolina.

Many ecological situations may be upset by effects of radioactive fallout on insect populations.¹ In particular, beta radiation from fallout may be hazardous to small insects and to insects that pass developmental stages in the soil and litter. Although some information is available on arthropod responses to beta and gamma radiation, it is meager and must be augmented to predict patterns of ecological responses to a nuclear attack and to plan postattack agricultural procedures.

The objective of this study is to assess effects of ionizing radiation from fallout on insects. Collembola were chosen for the laboratory experiments because they are among the most numerous microarthropods in the soil fauna and are important in soil formation. The study, a correlation of field and laboratory data, deals with succeeding levels of ecological complexity: (1) effects of chronic beta radiation on population mortality and fertility and (2) responses of the structure of an arthropod community in a managed grassland ecosystem to beta and gamma radiation. This paper covers the first 2 years of observations on the arthropod community.

Antecedent to any evaluation of radiation effects is the necessity of selecting an accurate, dependable, and practical method of determining radiation levels. Standard means of measuring radiation levels in contaminated areas (ionization chambers, scintillation counters, G-M counters, or silver-activated metaphosphate glass dosimeters) were not feasible in this study, in some instances owing to expense and/or component materials. Furthermore, these devices are not well suited for measurements of dose rates in microhabitats where radiation levels may be low, and most do not measure beta radiation. Existing mathematical models²⁻⁴ for predicting beta- and gamma-radiation dose rates from fallout were inadequate for this study because models are limited in ecological situations by restrictions in geometry, such as surface conditions, presence of grass, and movement of fallout.⁵ Thermoluminescent dosimeters were selected for use since they are mechanically rugged, are available in several geometries and sizes, and measure doses as low as 5 mrad.

METHODS

The study of the effects of simulated radioactive fallout on an in situ arthropod community was conducted at the 0800 Ecology Research Area at the Oak Ridge National Laboratory (ORNL). A quantity of simulated fallout⁶⁻⁸ (2.44 Ci of ¹³⁷Cs on silica sand grains) estimated to give a dose rate of 100 mR/hr at 1 m above ground was applied⁹ in July and August 1968 to a 100-m² field enclosure of the managed grassland ecosystem dominated by *Festuca arundinacea* Schreb. Three sites in the field, one fenced with sheet metal, one fenced and contaminated with fallout, and one roped off, were sampled bimonthly during the first year and monthly thereafter. The roped area was established for comparison with the uncontaminated pen to detect possible

effects of the fencing, which was utilized to rodent-proof the pens and to minimize dispersal of the fallout simulant. Sampling was begun 4 months before application of the fallout simulant. Seventy-eight arthropod taxa were sorted from samples collected with pitfall traps (12.2 cm deep by 6.7 cm in diameter), soil cores (5.0 cm long by 4.4 cm in diameter),¹⁰ and biocoenometers (cylindrical cages 0.25 m² by 1 m in height).¹¹

Beta- and gamma-radiation dose rates in the contaminated enclosures were determined by using cleaved (1 mm³) and extruded 0.5- by 6.0-mm crystals of LiF (Harshaw Chemical Co. TLD-100). This material was used because it is essentially energy independent for beta and gamma radiation. Beta and gamma point dosimetry was begun with the first application of fallout simulant. Extruded crystals of LiF were suspended at several heights above the ground. Some dosimeters were unshielded, and others were enclosed in 2-mm-thick nylon capsules, which were sufficient to shield out the beta radiation but not the gamma radiation. Extruded crystals were placed in and on grass stems and leaves; cleaved crystals were attached to insects during the eighth week after application of fallout simulant.

For the Collembola population study, albite sand grains (44 to 88 μ in diameter) coated with ⁹⁰Sr-⁹⁰Y (Ref. 12) were suspended in glycerol and painted onto charcoal-calcium sulfate substrates in culture jars 4 cm in diameter. Nonradioactive sand grains in glycerol were similarly applied to charcoal-calcium sulfate substrates to prepare control culture jars. Surface dose rates of 3.3, 4.8, 5.1, 5.2, 7.9, 13.5, 14.5, 15.5, 15.6, 17.4, 22.9, 29.0, 29.5, 35.4, 45.9, 66.0, 71.8, 89.1, and 341.7 rads/hr were determined for these plane sources using 0.5- by 6.0-mm extruded LiF crystals. Groups of 8 to 12 adult *Folsomia* species were placed in 10 control and in 19 experimental culture jars. The culture jars were maintained at 20°C, and the substrates were kept saturated with water. The Collembola were fed brewer's yeast, and numbers of adults, juveniles, and eggs were scored biweekly for a period of 98 days.

RESULTS AND DISCUSSION

Soil, litter, and grass components of the grassland arthropod community received significantly different beta- and gamma-radiation exposures owing to changes in distribution of the fallout simulant and to the short range of ¹³⁷Cs beta particles. Gamma and gamma + beta dose rates integrated over the first week in the middle of the contaminated field enclosure (Fig. 1) can be used to estimate the beta-radiation dose rates. Beta particles in air and vegetation have limited ranges, of course, and beta dose rates were used to estimate the vertical distribution of fallout for the point at which the series of dosimeters was suspended. Beta-radiation dose rates during the first week following application indicated that 25 to 30% of the simulant was present on the ground surface, 45 to 50% in the litter layer, and 20 to 30% on leaf surfaces. Eleven weeks after the

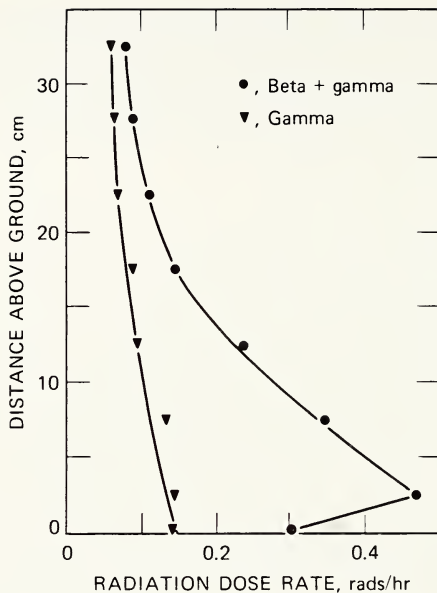

Fig. 1 Distance above ground plotted against gamma and beta + gamma dose rates in the middle of the contaminated enclosure at the 0800 Ecology Research Area during the first week after application of simulated radioactive fallout. The distance between the two dose-rate lines represents the beta-radiation dose rate. N for each point is 2.

first application and eight weeks after the second dosing of simulant (Fig. 2), 50 to 55% of the beta dose appeared on the ground surface, 25 to 30% was delivered in the litter layer, and less than 10% was present at the height of leaf surfaces. Microdosimeters placed on and in grass stems and leaves (Fig. 2) showed that most of the intercepted simulant had been removed from leaf surfaces but some remained trapped in leaf axils. Beta + gamma dose rates in axils ranged from 931 to 1145 mrad/hr, as compared with air dose rates at the same height above ground of 200 to 250 mrad/hr.

Grasshoppers (*Melanoplus* species) and crickets (*Acheta domesticus*) with cleaved crystals of LiF attached to their thorax and abdomen were released in the contaminated enclosure the eighth week after the second application of fallout simulant (Table 1). The dosimeters integrated the dose received by the insects as they moved through various dose-rate levels and thereby provided realistic estimates of "ecological dosimetry."¹³ Differences between dose rates to thorax and abdomen of the same insects were not significant, but there was a significant difference ($P \leq 0.01$) between total exposures of the living grasshoppers and crickets. These two insects are closely related taxonomically, but they occupy different habitats. Crickets dwell primarily on and in litter, where,

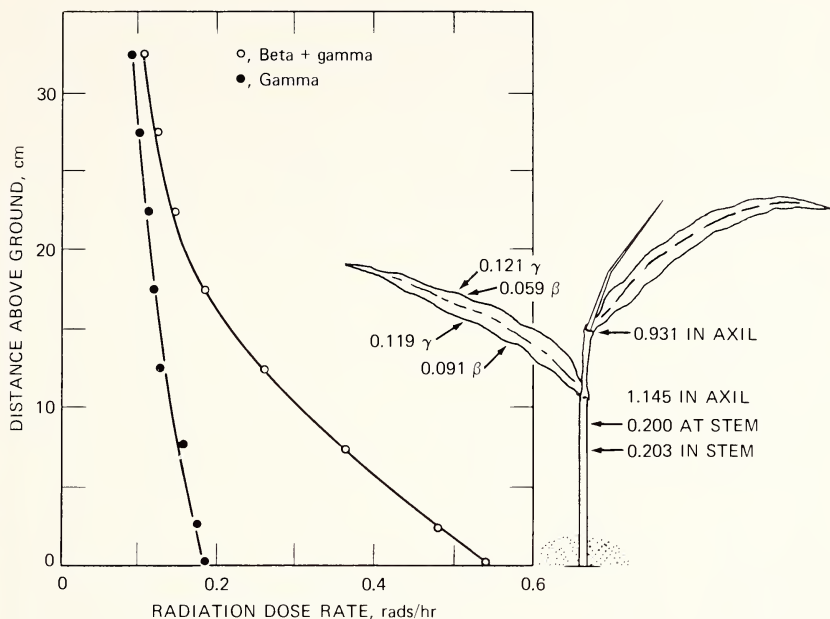

Fig. 2 Distance above ground plotted against gamma and beta + gamma dose rates in the middle of the contaminated enclosure at the 0800 Ecology Research Area during the eleventh week after the first application and the eighth week after the second application of simulated radioactive fallout. The distance between the two dose-rate lines represents the beta-radiation dose rate. Beta, gamma, and the combined dose rates observed for a fescue plant also are presented. N for each point on the dose-rate lines, as well as for the fescue plant, is 2.

Table 1

DOSE RATE TO CRICKETS (*Acheta domestica*)
AND GRASSHOPPERS (*Melanoplus* SPECIES) FROM
SIMULATED RADIOACTIVE FALLOUT EIGHT WEEKS
AFTER APPLICATION OF 2.44 CI/100 M² OF ¹³⁷Cs

Organism	Dose rate, rads/hr*	
	Thorax	Abdomen
<i>Acheta domestica</i> , living	0.22 ± 0.003	0.31 ± 0.010
<i>Melanoplus</i> species, living	0.09 ± 0.011	0.10 ± 0.007
<i>Melanoplus</i> species, phantom	0.11 ± 0.005	0.20 ± 0.006

*Plus or minus standard error; N = 10.

in this instance, they were exposed to more beta radiation; grasshoppers dwell higher, on blades of grass. Thus any attempt to predict ecosystem responses to radioactive fallout based on different radiation sensitivities must also deal with the problem of differential radiation exposure.

Biological data in the form of numbers of individuals of each arthropod taxon collected from the managed grassland arthropod community by each pitfall trap, soil core, or biocoenometer are too extensive for presentation here and will be included in a later report. A sequential three-way analysis of variance was applied to data from 26 sampling dates (Apr. 1, 1968, to Mar. 18, 1970) to detect significant changes in structure of the community. Variation among sites, taxa, and sampling dates was first calculated by using the seven sampling dates (Apr. 1 to June 25, 1968) before application of the fallout simulant. An F test indicated significant differences among dates ($P \leq 0.01$) and taxa ($P \leq 0.01$) but not between the control and the contaminated pens nor between either pen and the roped area. Differences among sampling dates would be expected because of seasonal responses of the arthropod community, and differences among taxa would be expected because the taxa normally occur at different population densities. Since original areas possessed comparable arthropod species compositions, subsequent differences in community structure cannot be attributed to any pretreatment variabilities. An analysis of all 26 sampling dates confirmed the difference among dates ($P \leq 0.01$) and among taxa ($P \leq 0.01$) as well as the lack of a significant difference among sites. When initial sampling dates were sequentially deleted and the analysis of variance repeated after each deletion, the only significant difference appearing between the control and the contaminated communities occurred 18 weeks after application of the fallout simulant ($P \leq 0.05$). At this time the soil component of the arthropod community had received 1789 rads of beta + gamma dose (Table 2), the litter component 1724 rads, and the grass component 373 to 1295 rads (variable as a function of height). Continuation of this analysis indicated no other significant differences between the arthropod communities. At the time of the 26th sampling date (Mar. 18, 1970), the soil component of the arthropod community had received 7786 rads of beta + gamma dose, the litter component 7165 rads, and the grass component between 1594 and 5404 rads.

For interpreting changes in arthropod community structure through time, an index of species composition dissimilarity¹⁴⁻¹⁷ was calculated for each sampling date and site pair combination; control enclosure vs. roped area, control enclosure vs. contaminated enclosure, and roped area vs. contaminated enclosure. The number of individuals of each arthropod taxon collected from a site on each sampling period was transformed^{15,16} and used to calculate in Euclidean hyperspace the species composition distance, d , between each pair of sites by the following equations:

$$X = \log(y + 1) \quad (1)$$

$$d_{ij}^2 = (X_{1,i} - X_{1,j})^2 + (X_{2,i} - X_{2,j})^2 \dots + (X_{78,i} - X_{78,j})^2 \quad (2)$$

Table 2

TOTAL DOSE FROM SIMULATED RADIOACTIVE FALLOUT TO THREE COMPONENTS OF THE MANAGED GRASSLAND ARTHROPOD COMMUNITY*

Year	Sampling date	Time after simulant application, weeks†	Total doses to arthropod compartments,‡ rads		
			Soil surface	Litter	Grass
1968	Aug. 20	2.0	338	407	77 to 300
	Sept. 10	4.9	601	645	131 to 481
	Sept. 24	6.9	782	810	168 to 605
	Oct. 30	12.0	1245	1230	262 to 922
	Dec. 10	18.0	1789	1724	373 to 1295
1969	Feb. 12	27.1	2459	2232	501 to 1685
	Mar. 6	30.4	2914	2744	602 to 2066
	Mar. 27	33.4	3186	2991	658 to 2253
	Apr. 30	38.1	3613	3378	744 to 2545
	May 6	39.0	3694	3452	761 to 2601
	July 1	46.9	4411	4103	907 to 3092
	July 15	48.9	4592	4267	944 to 3216
	Aug. 8	52.4	4910	4555	1009 to 3434
	Oct. 9	61.3	5717	5288	1173 to 3987
	Oct. 24	63.4	5908	5461	1212 to 4117
	Nov. 26	68.1	6334	5848	1299 to 4409
Dec. 17	71.1	6606	6095	1354 to 4596	
1970	Feb. 11	79.1	7332	6753	1502 to 5093
	Mar. 18	84.1	7786	7165	1594 to 5404

*No radiation dose was detected during seven sampling periods from Apr. 1 to June 25, 1968, prior to fallout-simulant application.

†Date of final application of fallout simulant was Aug. 5, 1968.

‡Soil component is at 0.0 cm above ground, litter component at 0.1 to 2.5 cm, and grass component at 2.6 to 32.5 cm.

$$d_{ij} = (d_{ij}^2)^{1/2} \quad (3)$$

where y = number of each taxon collected from each site

d_{ij} = species composition distance between sites i and j

$X_{1,i}$ = value of taxon 1 for site i

$X_{1,j}$ = value of taxon 1 for site j

etc.

The lower the value of d , the greater is the similarity between sites, and vice versa. Results of this analysis (Fig. 3) indicate a seasonal cycle in species composition. Minimums were reached during the winter months, and maximums

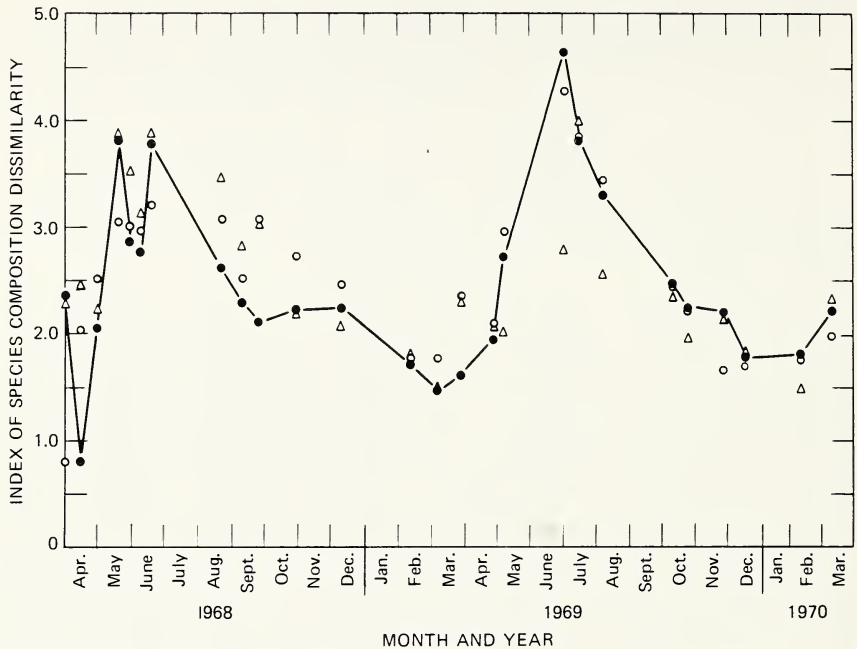

Fig. 3 Index of species composition dissimilarity for the control enclosure vs. the roped area (○), for the control enclosure vs. the contaminated enclosure (●), and for the roped area vs. the contaminated enclosure (△) plotted against each sampling date. The effects of changes in species composition in the enclosures is superimposed on a seasonal cycle with minimums of species composition in winter and maximums in summer.

occurred during the summer months. During the winter fewer taxa are active, and the inactive taxa would not contribute to a higher index of dissimilarity. A larger number of active taxa during the summer leads to a greater possible dissimilarity between sites. This sensitive technique¹⁸ for comparison of data shows no significant or consistent change in the dissimilarity between the contaminated pen and either the control pen or the roped area. This analysis indicates that effects of fallout radiation on arthropod species composition of the grassland would not be expected below 13 rads/day delivered over a period of 19 months, a fact also demonstrated in the less rigorous analysis of variance. A likely explanation for this lack of radiation effect lies in the homeostatic mechanisms that enable the community to react to radiation stress in the same manner as to other environmental stresses.⁵ The possibility also exists that, in the context of an entire ecosystem, populations exhibit threshold responses to ionizing radiation. Future analyses, to determine whether either of these suggestions is correct, will be directed toward describing responses of populations and of the soil-litter-grass compartments of the arthropod community.

Additional insights into population responses in fallout areas have been provided by a correlative laboratory study on *Folsomia* species. Survival and reproductive ability of these Collembola were reduced at all 19 beta dose rates tested. The $LDR_{50/30}$ (dose rate estimated to kill 50% of the population in 30 days) for chronically irradiated adults was estimated by least-squares regression analysis to be 174.5 rads/hr (total dose in 30 days of 125.6 krad) and the $LDR_{50/60}$ to be 38.1 rads/hr (total dose in 60 days of 54.9 krad). The effects of chronic beta radiation on fecundity rates (Fig. 4) could not have been anticipated from studies^{19,20} of the effects of acute irradiation alone. After an acute dose of ionizing radiation, fecundity rate of each population was reduced. Under chronic irradiation conditions, however, all fecundity rates were initially at control levels, but rates were reduced through time as doses were accumulated. Change in fecundity rates under chronic irradiation conditions must therefore be represented as the slope of a regression line rather than as a

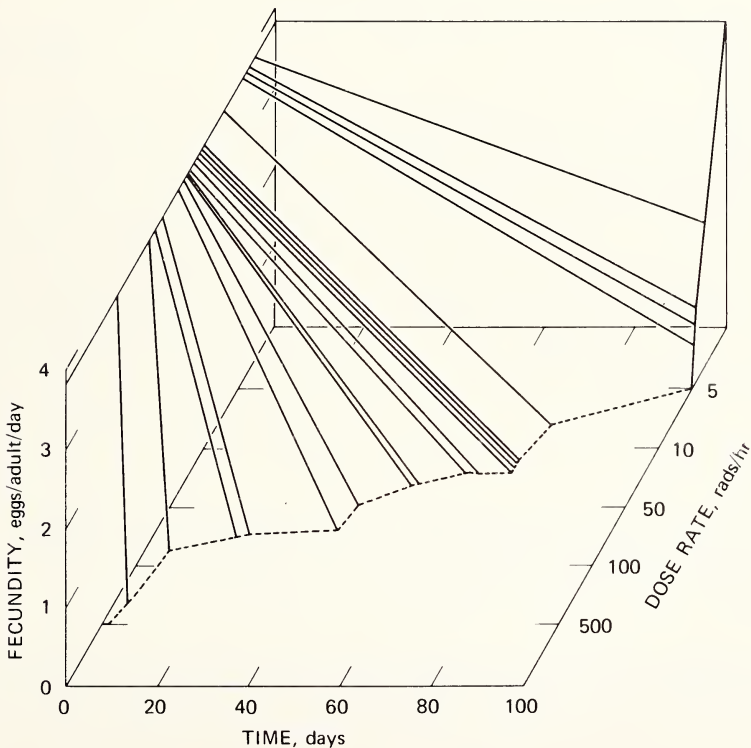

Fig. 4 Isometric projection of fecundity in eggs per adult per day on time in days and ^{90}Sr - ^{90}Y beta-radiation dose rate for *Folsomia* species for continuous exposure at the indicated dose rates. The fecundity rates for each dose rate are presented as a regression on time since the fecundity of each population changed as the total doses of radiation were accumulated.

point. At dose rates greater than 5 rads/hr, fecundity rates rapidly approached zero. Egg mortality (Fig. 5) was increased by chronic dose rates above 13.5 rads/hr, and no eggs hatched at dose rates above 17.4 rads/hr. At 14.5 rads/hr, 38% of the eggs matured into adults, but all were sterile.

These data demonstrate that radiosensitivity of a population of *Folsomia* to beta radiation is manifest primarily in the effect on fertility rates (number of

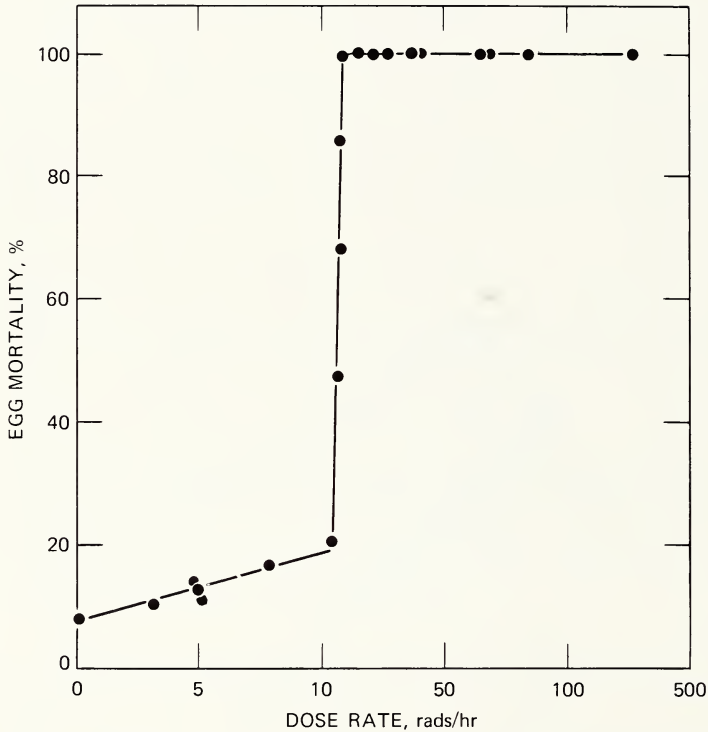

Fig. 5 Egg mortality plotted against ^{90}Sr - ^{90}Y beta-radiation dose rate for *Folsomia* species for continuous exposure at the indicated dose rates. The point at 0 rads/hr represents the mean of 10 control populations.

eggs surviving) rather than on mortality rates of adults. Dose rates estimated to give an $\text{LDR}_{50/30}$ or $\text{LDR}_{50/60}$ for adults are more than twice as high as dose rates required to reduce fertility to zero. Sensitivity of fertility rates to acute irradiation has been demonstrated for another Collembolan (*Sinella curviseta*) population.¹⁹ For the acute irradiation regime in that study, substantial recovery occurred several weeks following irradiation. If a natural population of these Collembola were subjected to acute irradiation during a seasonal cycle of low reproductive activity, recovery could occur before the population entered its

period of maximum reproductive activity. The ecological significance of the sensitivity of fertility rates could thus be masked by seasonal cycles in reproduction. This situation would not be expected to occur for populations under chronic irradiation conditions, since recovery could not occur.

ACKNOWLEDGMENTS

This research was sponsored by the Office of Civil Defense, Department of Defense, and the U. S. Atomic Energy Commission under contract with the Union Carbide Corporation.

We are indebted to Nancy Troyer and John Rhoderick of St. Andrews Presbyterian College for assistance during the course of these experiments.

REFERENCES

1. P. W. Wong, Initial Study of the Effects of Fallout Radiation on Simple Selected Ecosystems, Report USNRDL Tr-68-11, Naval Radiological Defense Laboratory, 1967.
2. S. L. Brown, Disintegration Rate Multipliers in Beta-Emitter Dose Calculations, USAEC file No. NP-15714 (SRI Report MU-5116), Stanford Research Institute, August 1965.
3. C. F. Miller, Fallout and Radiological Countermeasures. Vol. I, Report AD-410522 (SRI Project No. Im-4021), Stanford Research Institute, January 1963.
4. G. B. Curtis and J. S. Petty, A Program to Compute Beta Radiation Dosage. Vol. I. Program Description. Final Report, USAEC Report TID-24033 (Vol. 1), American Research Corporation, Aug. 1, 1967.
5. R. B. Platt, Ionizing Radiation and Homeostasis of Ecosystems, in Ecological Effects of Nuclear War, G. M. Woodwell (Ed.), USAEC Report BNL-917, pp. 39-60, Brookhaven National Laboratory, August 1965.
6. W. B. Lane, Fallout Simulant Development: Temperature Effects on the Sorption Reactions of Cesium on Feldspar, Clay, and Quartz, SRI Project No. MU-6014, Stanford Research Institute, 1967.
7. S. I. Auerbach, Introduction, Progress Report in Postattack Ecology, USAEC Report ORNL-TM-2466, p. 1, Oak Ridge National Laboratory, March 1969.
8. R. C. Dahlman and S. I. Auerbach, Preliminary Estimation of Erosion and Radiocesium Redistribution in a Fescue Meadow, USAEC Report ORNL-TM-2343, Oak Ridge National Laboratory, November 1968.
9. R. C. Dahlman, Retention of Fallout Particles by Fescue Grass, in Progress Report in Postattack Ecology, USAEC Report ORNL-TM-2983, pp. 24-43, Oak Ridge National Laboratory, December 1970.
10. S. I. Auerbach and D. A. Crossley, Jr., A Sampling Device for Soil Microarthropods, *Acarologia*, II(3): 279-287 (1966).
11. A. L. Turnbull and C. F. Nicholls, A "Quick-Trap" for Area Sampling of Arthropods in Grassland Communities, *J. Econ. Entomol.*, 59: 1100-1104 (1966).
12. J. P. Witherspoon and F. G. Taylor, Effects of External Beta Radiation on Higher Plants, in Progress Report in Postattack Ecology, USAEC Report ORNL-TM-2466, pp. 2-17, Oak Ridge National Laboratory, March 1969.

13. J. J. Cowan and R. B. Platt, Radiation Dosage in the Vicinity of an Unshielded Nuclear Reactor in *Radioecology*, Proceedings of the first national symposium, Sept. 10-15, 1961, Fort Collins, Colo., V. Schultz and A. W. Klement, Jr. (Eds.), pp. 311-318, Reinhold Publishing Corporation, New York, 1963.
14. P. Greig-Smith, *Quantitative Plant Ecology*, pp. 178-179, Butterworth & Co. (Publishers) Ltd., London, 1964.
15. R. R. Sokal, Numerical Taxonomy, *Sci. Amer.*, **215**(6): 106-116 (1966).
16. R. R. Sokal and P. H. A. Sneath, *Principles of Numerical Taxonomy*, pp. 176-180, W. H. Freeman and Company, San Francisco, 1963.
17. L. Orloci, Geometric Models in Ecology. I. The Theory and Application of Some Ordination Methods, *J. Ecol.*, **54**: 193-215 (1963).
18. G. M. Woodwell, Radiation and the Patterns of Nature, USAEC Report BNL-924, Brookhaven National Laboratory, Mar. 24, 1965.
19. C. E. Styron, Effects of Beta and Gamma Radiation on *Sinella curviseta* (Collembola), in Progress Report in Postattack Ecology, USAEC Report ORNL-TM-2466, pp. 40-46, Oak Ridge National Laboratory, March 1969.
20. R. V. O'Neill and C. E. Styron, Applications of Compartment Modeling Techniques to Collembola Population Studies, *Amer. Midland Natur.*, **83**: 489-495 (1970).

SURVIVAL OF CRICKETS, *Acheta domesticus* (L.), AS AFFECTED BY VARIATIONS IN GAMMA DOSE RATE

R. I. VAN HOOK, JR.

Ecological Sciences Division, Oak Ridge National Laboratory, Oak Ridge, Tennessee

ABSTRACT

Effects of 5000 rads of gamma radiation delivered at five different dose rates on the survival of young adult crickets, *Acheta domesticus* (L.), were determined. Significant ($P \leq 0.05$) differential mortality occurred as a function of dose rate. Lower dose rates resulted in reduced mortality. Mortality increased with increasing dose rate up to 200 rads/hr, above which further increases in irradiation intensity produced very similar mortality rates.

Predictions of responses of arthropod populations to ionizing radiations, such as those produced by fallout from a nuclear burst, are based in great part on laboratory studies utilizing acute doses. If these data are to be relevant to fallout situations where these natural populations also would receive chronic exposures, variations in dose rate must be carefully considered. Ideally dose rates used in laboratory studies should remain essentially constant¹ and should be the same as those encountered in fallout fields. However, this is impractical in instances where (1) an accumulation of a significant dose is impossible because of a low fallout-radiation dose rate and relatively short arthropod life-span and (2) the fallout-radiation dose rate is substantially less than that available from laboratory sources. In these instances it becomes necessary to make the assumptions that no dose-rate effect is present and that the effects observed from high dose rates in laboratory studies can be extrapolated to estimate the effects of low fallout dose rates. To determine the validity of this assumption, we initiated an experiment to estimate the survival of adult crickets following a dose of about 5000 rads delivered at five different dose rates.

METHODS AND MATERIALS

Adult crickets, *Acheta domesticus* (L.), were obtained from stock laboratory cultures maintained at 28°C and approximately 50% relative humidity. Three replicates of 25 insects each were irradiated with ⁶⁰Co sources at dose rates of 30, 70, 210, 2500, and 23,800 rads/hr. Total dose received was about 5000 rads, the approximate LD_{50/20} gamma dose for *Acheta*.² Silver metaphosphate glass rods were used for dosimetry measurements. All crickets were maintained in plastic cages at 28°C and approximately 50% relative humidity with food and water provided ad lib. Cricket survival was recorded daily and was corrected from control mortality by the equation

$$\text{Net \% mortality} = \frac{\% \text{ mortality (treated)} - \% \text{ mortality (control)}}{100 - \% \text{ mortality (control)}} \quad (1)$$

Resulting data were analyzed in a 2 × 2 factorial analysis of variance of dose rate against time. Mean responses were separated by using Duncan's New Multiple Range Test.

RESULTS AND DISCUSSION

Survival curves (Fig. 1) plotted as net percent survival (100 - net percent mortality) vs. time showed a fairly typical radiation response by *Acheta* to 5000 rads at the three higher dose rates (210, 2500, and 23,800 rads/hr). For each of these dose rates, there was a 3- to 4-day latent period when mortality remained essentially negligible. This was followed by an abrupt and relatively constant decrease in net survival resulting in total mortality about 16 days posttreatment.

A dose rate of 70 rads/hr produced a response which duplicated that of the three higher dose rates through about the ninth day postirradiation. The radiation effect on *Acheta* survival then leveled off and remained relatively constant for the next 7 days. Net survival began to increase on day 16 postirradiation, apparently owing to "repair" of radiation damages. This increase continued through day 24; then survival declined to zero by day 31 postirradiation.

Under chronic irradiation stress (30 rads/hr), net percent survival decreased at a gradual rate during the first 20 days postirradiation (80% net survival at 20 days). However, a significant effect ($P \leq 0.05$) was observed through time when survival at this dose rate was compared with that of the control groups. *Acheta* survival continued to decrease through day 42, when net percent mortality reached 100%.

Mean expectation for future life (e_x) determined by life-table analysis³ and estimated total gamma dosages are shown in Table 1 for the control group and the

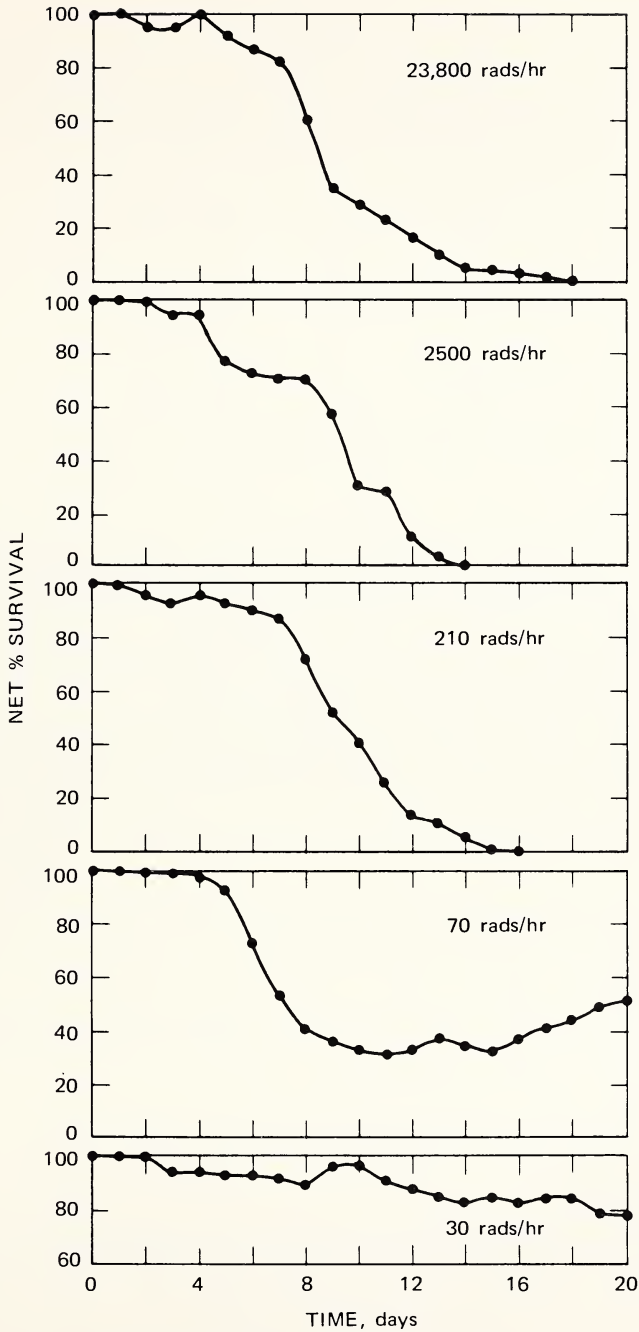

Fig. 1 Net survival of young adult crickets (*Acheta domesticus*) following a dose of about 5000 rads of gamma radiation at five different dose rates.

Table 1

MEAN EXPECTATION FOR FUTURE LIFE (e_x) FOR YOUNG ADULT *Acheta domesticus* AFTER RECEIVING ABOUT 5000 RADS OF GAMMA RADIATION AT FIVE DIFFERENT DOSE RATES

Treatment, rads/hr	e_x , days	Estimated total dose, rads*
Control	27.7	
30	23.4	5002 \pm 250
70	12.7	4637 \pm 149
210	7.8	4997 \pm 359
2,500	7.0	5098 \pm 281
23,800	8.4	5000 \pm 250

*Means \pm one standard error; N = eight glass-rod dosimeters.

five dose rates. Mean life expectancy for young adult crickets exposed to 5000 rads of gamma radiation was not significantly depressed by the chronic irradiation dose rate (30 rads/hr). Significant depression of e_x did occur for each of the remaining dose rates employed, the highest three rates producing essentially the same effect. The errors associated with glass-rod dose estimation ranged from 3 to 7% of the total absorbed gamma dose.

Mean net percent mortality at 20 days postirradiation expressed as a function of dose rate for adult *Acheta* following a dose of 5000 rads of gamma radiation is shown in Fig. 2. A dose-rate effect was readily apparent as the rate increased from a chronic (30 rads/hr) to a more acute level (>70 rads/hr). At the

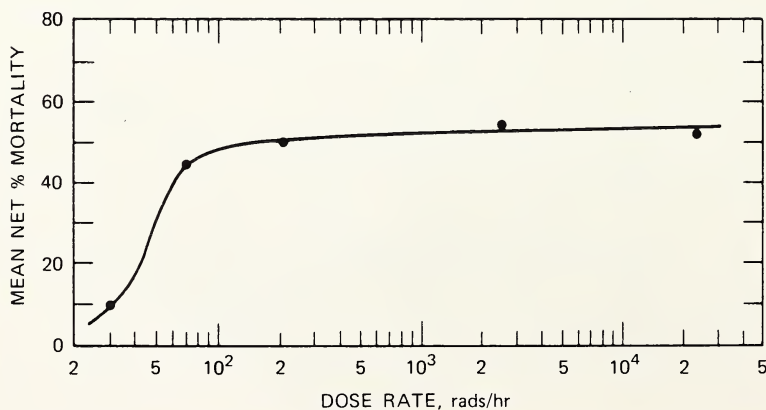

Fig. 2 Net percent mortality after 20 days expressed as a function of dose rate for young adult crickets (*Acheta domesticus*) after they received about 5000 rads of gamma radiation.

lower dose rate, mortality was significantly less ($P \leq 0.05$) than that at the higher rates. Similar results were reported by Sievert and Forssberg^{4,5} for X irradiation of *Drosophila* eggs. They found that dose rates of less than 300 rads/hr were only slightly injurious to developing eggs and that doses delivered at very high intensities ($>280,000$ rads/hr) killed a larger proportion of eggs than did similar doses at moderate intensities. Banham⁶ demonstrated that survival of adult flour beetles, *Tribolium confusum*, at 4000 rads/hr was much reduced compared with that at 2000 rads/hr for a given total gamma dose. For dose rates ranging from 1500 to 4700 rads/hr, Jefferies and Banham¹ reported an increase in mortality to a given total gamma dose for the grain pests *Tribolium*, *Oryzaephilus*, and *Sitophilus*. Fertility is also reduced by increasing dose rate for a given dose in *Tribolium*.⁷ McMahan⁸ reported that both 2520 and 36,900 rads/hr resulted in increased mortality of three termite species, but the dose rate had to be high before the total dose received could produce significant differential mortality.

A leveling off of the dose-rate-effect curve (Fig. 2) began at about 200 rads/hr; no significant differences occurred at the higher dose rates ($P \leq 0.05$). This leveling off of the dose-rate-effect curve has been reported for other insect species^{1,6,7,9} and has led several investigators to conclude that commonly used laboratory irradiation dose rates do not vary enough to produce a significantly different radiosensitivity end point.^{10,11} On the basis of the results of the present study and on those of several earlier works,^{1,6,7,8} this conclusion should be modified to apply only to the plateau region of the dose-rate-effect curve since significant differential radiosensitivity does occur in the lower regions of the curve.

CONCLUSIONS

This study indicates that, when mortality is used as a biological end point, Orthoptera may be irradiated at relatively high dose rates to achieve an effect similar to that expected from exposure to chronic fallout radiation. This is particularly true when the results of a laboratory study are applied to conditions that would exist during the first few weeks immediately following fallout deposition when the majority of the biological damage from fallout radiation would occur.¹² During this time the dose rate is undergoing a rapid exponential reduction, and the range of dose rates would fall within those found not producing significantly different biological effects in laboratory studies. The primary advantage of using high dose rates in irradiation studies is that lethal exposures may be attained in short periods of time. This is an important consideration since the life-span of most arthropod species is such that accumulation of a lethal dose from fallout radiation would require several generations. The immediate effects of fallout radiation on survival of the population would not be discernible. Any effects on survival would probably show up in the F_1 or F_2 generation.

ACKNOWLEDGMENTS

This research was sponsored by the U. S. Atomic Energy Commission and the Office of Civil Defense, Department of Defense, under contract with Union Carbide Corporation.

I wish to thank Gladys J. Dodson for technical assistance during the course of this investigation. J. J. Beauchamp, Statistics Department, Mathematics Division, ORNL, assisted with the statistical analyses of the data.

Portions of this study were conducted in the ^{60}Co whole-body irradiator at the UT-AEC Agricultural Research Laboratory, Oak Ridge, Tenn.

REFERENCES

1. D. J. Jefferies and E. J. Banham, The Effect of Dose Rate on the Response of *Tribolium confusum* Duv., *Oryzaephilus surinamensis* (L.) and *Sitophilus granarius* (L.) to ^{60}Co Gamma Radiation, in *The Entomology of Radiation Disinfestation of Grain*, P. B. Cornwell (Ed.), pp. 177-85, Pergamon Press, Inc., New York, 1966.
2. E. F. Menhinick and D. A. Crossley, Jr., A Comparison of Radiation Profiles of *Acheta domesticus* and *Tenebrio molitor*, *Ann. Entomol. Soc. Amer.*, **61**(6): 1359-1365 (1968).
3. E. S. Deevey, Jr., Life Tables for Natural Populations of Animals, *Quart. Rev. Biol.*, **22**: 283-314 (1947).
4. R. Sievert and A. Forssberg, The Time Factor in the Biological Action of X Rays, *Acta Radiol.*, **12**: 535-551 (1931).
5. R. Sievert and A. Forssberg, The Time Factor in Röntgen Radiations of Extremely Short Duration, Investigations on *Drosophila* Eggs, in *Third International Congress of Radiology, Resumes des Communications*, p. 263, Paris, 1931.
6. E. J. Banham, The Susceptibility of the Confused Flour Beetle (*Tribolium confusum* Duv.) to Gamma Radiation, British Report AERE-R-3888, March 1962.
7. K. K. Nair and G. Subramanyam, Effects of Variable Dose Rates on Radiation Damage in the Rust-Red Flour Beetle, *Tribolium castaneum* Herbst, in *Radiation and Radioisotopes Applied to Insects of Agricultural Importance*, Symposium Proceedings, Athens, Apr. 22-26, 1963, pp. 425-429, International Atomic Energy Agency, Vienna, 1963 (STI/PUB/74).
8. E. A. McMahan, Effects of Ionizing Radiation on Three Neotropical Termite Species, *Ann. Entomol. Soc. Amer.*, **62**(1): 120-125 (1969).
9. G. A. Zakladnoi, Influence of the Gamma Irradiation Dose Rate on the Lifetime of Granary Weevils, *Radiobiologiya*, **6**(3): 199-201 (1966).
10. C. Packard, The Relationship Between Age and Radiosensitivity of *Drosophila* Eggs, *Radiology*, **25**: 223-230 (1936).
11. R. D. O'Brien and L. S. Wolfe, *Radiation, Radioactivity, and Insects*, Academic Press, Inc., New York, 1964.
12. C. F. Miller and P. D. LaRiviere, Introduction to Long-Term Biological Effects of Nuclear War, USAEC file No. NP-16462 (SRI Report MU-5779), Stanford Research Institute, April 1966.

EFFECTS OF BETA-GAMMA RADIATION OF EARTHWORMS UNDER SIMULATED-FALLOUT CONDITIONS

DAVID E. REICHLER, JOHN P. WITHERSPOON,
MYRON J. MITCHELL,* and CLARENCE E. STYRON†

Ecological Sciences Division, Oak Ridge National Laboratory, Oak Ridge, Tennessee

ABSTRACT

Experiments on ^{60}Co gamma and ^{90}Sr - ^{90}Y beta radiosensitivity of *Lumbricus terrestris* and dosimetry models of soil systems were designed to study the effects of fallout radiation on natural earthworm populations. Epithelial tissues (skin and/or intestinal) were the primary sites for radiation damage. The $\text{LD}_{50/30}$ days for gamma was 67.8 krad; no significant increase in mortality occurred for beta irradiations up to 102.4 krad. In situ dosimetry models with ^{137}Cs show that beta radiation is important only for direct contact (because of soil shielding) and that gamma radiation typically would contribute from 68 to 100% of the external body dose of natural populations. Habitat shielding, high radioresistance of earthworms, and radioactive decay preceding particle incorporation into soil suggest minimal population mortality due to radiation from anticipated weapon yields.

The delivery of external radiation exposure dose to biological systems at specific locations in a fallout field is generally in the form of an acute or short-term damage phenomenon.¹ Because of the paucity of data on effects of beta dose on invertebrates,² the effects of beta and gamma radiation from nuclear fallout generally had been assumed to be comparable. Recent information on contaminated-particle retention by vegetation³ and contact doses from beta radiation⁴ suggests that areas of serious damage to organisms from fallout will be larger than previously estimated from gamma radiation alone. Since fallout deposition initially tends to move toward and concentrate at the soil surface

*Present address: Environmental Sciences Center, The University of Calgary, Alberta, Canada.

†Present address: Division of Mathematics and Natural Science, St. Andrews Presbyterian College, Laurinburg, North Carolina.

through the action of meteorological factors, estimates of a total effective fallout dose⁵ 40 times that previously considered have raised concern about the response of litter- and soil-dwelling invertebrate populations to nuclear fallout.

Earthworms, a major element of the soil fauna, are important in maintaining many natural soil characteristics, e.g., aeration, water permeability, and nutrient turnover. The space occupied by earthworm burrows may account for as much as two-thirds of the air capacity of some soils, whereas a moderate-density field population (25/m²) may consume and turn over from 25 to 30 metric tons per hectare of aboveground organic-matter products.⁶ Therefore not only could the effects of radiation on this fauna have far-reaching implications in the ecosystem but their ecology could also play a major role in the redistribution of fallout particles within the soil. The experiments described in this paper on adult *Lumbricus terrestris* estimated their ⁶⁰Co gamma and ⁹⁰Sr-⁹⁰Y beta radiosensitivity and the incorporation of ¹³⁷Cs-tagged surface litter into soil profiles. The effects of external fallout radiation in the natural environment were estimated from dosimetry models based on anticipated weapon yields.

METHODS

Adult *Lumbricus terrestris* with mean live weight of 3.8 g, obtained from a commercial supplier (Sterchi Bait & Tackle Co., Knoxville, Tenn.), were maintained in damp peat moss at 5°C. Earthworms were irradiated at 5°C in groups of 10 with three replications at each dose level: 0, 25.6, 52.8, 76.8, and 102.4 krads for both beta and gamma irradiations. Irradiated groups of 10 animals were maintained at 5°C in 1 liter of old, damp peat moss under constant darkness. Cultures were examined thrice weekly and scored for mortality and obvious histological damage.

Gamma irradiations were performed with a Gammacell 200 ⁶⁰Co irradiator (Atomic Energy of Canada Ltd.) with an exposure dose rate between 8.16 and 8.11 rads/sec during the course of the experiments. Beta irradiations were administered from a ⁹⁰Sr-⁹⁰Y plaque source⁷ with a surface dose rate of 1.38 rads/sec (Ref. 8). Mean beta-particle energy from the source was 0.9 MeV.

RESULTS AND DISCUSSION

Mortality scores for irradiated animals were converted to normits⁹ for linear regressions. To estimate longevity of irradiated animals, we regressed the normit of percent mortality on time for each dose level. Resulting values of LT₅₀ (time for 50% lethality in the population) are presented in Table 1. Mean life-span for controls under culture conditions was 66 days, although no mortality occurred until day 24 of the experiments. The LT₅₀ dropped precipitously with increasing gamma dose, the mean life-span of earthworms irradiated at 102.4 krads being only 16 days with 97.5% population mortality after 30 days.

Table 1
NORMIT ANALYSIS FOR LT_{50} OF
Lumbricus terrestris TO GAMMA RADIATION*

Gamma Dose, rads	LT_{50} , days	$S_{yx}\dagger$	$r^2\ddagger$
0	66	0.2906	0.6765
25,600	53	0.0837	0.9101
51,200	42	0.0934	0.9509
76,800	38	0.1301	0.9349
102,400	16	0.2907	0.8988

*Values are based on eight 5-day sequential mortality estimates on groups of 10 earthworms replicated three times for each dose.

$\dagger S_{yx}$ is the standard error of the estimate (\hat{Y}).

$\ddagger r^2$ is the coefficient of determination.

Table 2
NORMIT ANALYSIS FOR LD_{50} OF
Lumbricus terrestris TO GAMMA RADIATION*

Time, days	LD_{50} , krads	$S_{yx}\dagger$	$r^2\ddagger$
10	147.9	0.2388	0.8000
15	121.8	0.3316	0.7372
20	94.1	0.4140	0.7561
25	83.2	0.4011	0.8191
30	67.8	0.3267	0.8278
34	61.5	0.2832	0.8191

*Values are based on five dose levels using groups of 10 earthworms replicated three times for each dose.

$\dagger S_{yx}$ is the standard error of the estimate (\hat{Y}).

$\ddagger r^2$ is the coefficient of determination.

Mean lethal doses were similarly calculated by regressing the normit of percent mortality on dose for varying time end points (Table 2). The well-known time-dependent dose phenomenon was apparent; increasingly lower doses were required to effect 50% mortality (LD_{50}) as the time over which the effect could be expressed increased. The $LD_{50/30}$ days was calculated to be 67.8 krads. These data suggest that *Lumbricus* are more radioresistant than previously reported by Hancock.¹⁰ Although Hancock's dose rate was higher (16.7 rads/sec of X rays), his estimate of 100 krads for an $LD_{50/35}$ is higher than that found in the present study. He also found no lethal effect at 45 krads after 67 days. The radiation sensitivity of other invertebrate species comprising the soil fauna¹¹⁻¹⁴ is greater than that reported here for earthworms.

Although identical surface-air doses were administered for both beta and gamma radiation, no significant mortality was observed for beta irradiations up to 102.4 krads during the 30-day experimental period. Unlike the gamma source, the beta plaque delivered, not a "bath" dose, but rather a contact dose with a plane source. The mean beta-particle ranges in soft tissue would be 2.1 mm for ^{90}Y and 0.33 mm for ^{90}Sr . In an adult *Lumbricus* of approximately 5 mm diameter, over 60% of the worm and its vital internal organs would be shielded. Therefore these data are not valid for comparisons of relative biological effectiveness.

When *Lumbricus* began to die after exposure to radiation, there was a general loss of pigment—probably protoporphyrin and protoporphyrin methyl ester¹⁵—and an associated loss of motor response in the posterior region. Sites of radiation damage for both beta and gamma radiation were the skin epithelium (blistering) and the intestinal epithelium (necrosis). Since beta irradiations were administered from the ventral surface with a plaque source, many earthworms showed a gradation in histological damage along the dorsoventral axis (Fig. 1). Note the necrotic condition of the ventral gut epithelium (0.5 to 0.7 mm); dorsal epithelium (1.5 to 1.8 mm) does not exhibit necrosis. Similar damage to epithelial tissue was noted throughout the intestinal tract and also for the epidermis (not shown in Fig. 1). Soil and muscle shielding would reduce the effect of most low-energy beta radiations from external sources (beta bath); however, the volume of soil consumed in the digestive process and the direct contact of soil particles with the radiosensitive intestinal epithelium could be important factors in highly contaminated soil. It would take internal contamination of the order of several microcuries per square centimeter to deliver acute tissue doses of the order of LD_{50} values.

Dose from fallout radiation to soil dwellers such as earthworms would be much reduced by the shielding properties of soil. For example, Table 3 gives beta and gamma exposure rates at various soil depths from ^{137}Cs in four different geometries. It was assumed that the activity was evenly dispersed in a 100-m^2 surface area of 0, 5, 10, and 20 cm thickness. A soil density of 1.46 g/cm^3 was used to calculate dose rate. In a true fallout situation, initial activity would be on the soil surface. This would be followed by an exponential decrease in dose rate with depth as soluble radionuclides and particles became redistributed in the mineral soil. Thus soil-dwelling organisms below 5 to 10 cm would be exposed to less radiation than if the activity were evenly distributed through a given soil thickness with the organisms in the middle of this "slab source."

On the basis of calculations for ^{137}Cs , about 743 Ci/m^2 would have to be deposited on the soil surface to deliver 67.8 krads (the $\text{LD}_{50/30}$) in 24 hr to earthworms located 1 cm below the surface. Every additional 5.5 to 8.5 cm of depth (depending on soil moisture) would represent a tenth value layer and thus would afford more shielding for worms below the 1-cm depth.



Fig. 1 Tissue necrosis 11 days postirradiation in the earthworm *Lumbricus terrestris* resulting from beta irradiation (51.2 krads ventral surface dose). vc, ventral nerve cord; vge, ventral gut epithelium; gl, gut lumen; dge, dorsal gut epithelium. Photograph is a transverse section in the region of the posterior pharynx. (Magnification, 82 x)

Table 4, calculated from data reported by Wong,⁴ gives estimated infinity doses of gamma and beta radiation from fallout on the soil surface following a 10-Mt weapon burst. Gamma doses between the 1000- and 2000-rad exposure-rate contours (rads/hr at 1 hr) are well below LD₅₀ values for earthworms. Although the contact beta doses for these areas are above LD₅₀ values, shielding by 1 cm of soil should essentially reduce the beta dose to zero.

Table 3
EXPOSURE DOSE RATES IN SOIL FROM ^{137}Cs IN DIFFERENT GEOMETRIES

Distribution of activity		Source geometry	Depth for exposure, cm	Dose rate, mrad/hr/Ci	% of dose	
Surface area, m ²	Depth, cm				Gamma	Beta
100	0	Plane	1.0	38	100.0	0
100	0 to 5	Slab	2.5	84	68.7	31.3
100	0 to 10	Slab	5.0	61	78.4	21.6
100	0 to 20	Slab	10.0	33	80.3	19.7

Table 4
APPROXIMATE INFINITY BETA AND GAMMA DOSES AT GROUND-SURFACE CONTACT RESULTING FROM A 10-MT WEAPON BURST WITH 50% FISSION YIELD*

Exposure-rate contour, rads/hr at 1 hr	Area within contour, sq miles	Infinity gamma dose,† rads	Infinity beta dose at contact, rads
1	4.6×10^4	4.6	1.4×10^2
10	2.5×10^4	4.6×10^1	1.6×10^3
50	1.4×10^4	2.3×10^2	8.9×10^3
100	1.0×10^4	4.6×10^2	1.9×10^4
200	6.7×10^3	9.3×10^2	4.1×10^4
500	3.8×10^3	2.3×10^3	1.1×10^5
1000	2.0×10^3	4.6×10^3	2.6×10^5
2000	7.3×10^2	9.3×10^3	6.0×10^5

*Data are recalculated from the original source.⁴

†Tissue dose.

Thus it seems reasonable that large-scale lethal effects on adult earthworms would not be expected as a consequence of detonations of nuclear devices. Other stages of the earthworm's life history may, however, be more radiosensitive. If we assume that 10% of the LD₅₀ dose may affect reproductive stages of a population, then fallout radiation doses and radioactivity values discussed here could be ecologically significant. The degree of significance would depend on the proportion of the total population represented by more radiosensitive stages and the soil depth in which they characteristically reside. Egg stages, for example, are immobile and tend to reside at a fixed soil depth.

After fallout radiation levels have decayed to a small fraction of the initial dose rates, earthworms may be important in distributing activity through soil. They would come into intimate contact with particles at this time, but dose to

organisms from external and internal sources would be small due to time and decay factors. Time required for turnover of topsoil in the 0 to 10 cm horizon due to the activity of earthworms has been estimated to range from 20 to 60 years, depending on habitat type.⁶ Thus the role of earthworms in the incorporation of a surface deposition of fallout would not appear to exceed other biotic and physical mechanisms. However, if the radioactive material should become associated with organic debris, earthworm activity could be significant. The quantity of organic material eaten or buried by earthworms is often limited solely by availability, rather than their ability to ingest it.⁶ In laboratory experiments *Lumbricus terrestris* rapidly consumed forest leaf litter. At a density of 120 g live weight/dm², worms completely removed 40 g of litter tagged with ¹³⁷Cs from the surface within 1 month. The associated ¹³⁷Cs was detectable to depths of 45 cm, highest concentrations occurring in the 15- to 30-cm zone. Since the various earthworm genera may be active to considerable depths in soil (0 to 25 cm for *Allobophora*, 0 to 50 cm for *Octolasion*, and up to 100 cm for *Lumbricus*), these animals could be important in the rapid mixing of fallout particles within soil horizons.

CONCLUSIONS

Earthworms appear to be among the least radiosensitive of the invertebrate organisms comprising the soil fauna. The LD_{50/30} for gamma radiation was 67.8 krads. No significant increases in mortality occurred at beta doses below 102.4 krads, probably because of muscle shielding from the external radiation field. In a natural situation with nuclear fallout deposition on the soil surface, earthworms would be substantially shielded from beta radiation and from a large portion of the gamma radiation. Even with subsequent mixing of fallout particles with soil, beta radiation would be significant only for direct contact and internal dose from absorbed radionuclides. Both intestinal and skin epithelia would receive gamma radiation and would be in physical contact with low-energy beta radiations and the abrasive action of soil particles. The time required for such mixing is long, even if earthworms are involved. Decay of fission products over this time would greatly reduce the quantities of radioactivity available for external or internal irradiation of the organisms. The high radioresistance of earthworms to both gamma and beta radiation indicates that there would be minimal population mortality due to radiation from anticipated weapons yields. Although immediate mortality would not be expected for adult earthworms at these fallout doses, this does not preclude the possibility of effects on juveniles or other population parameters such as fecundity, fertility, or other genetic responses. Generally, however, the soil fauna seem to be well shielded from the short-lived components of nuclear fallout radiation.

ACKNOWLEDGMENTS

This research was sponsored by the Office of Civil Defense, Department of Defense, and the U. S. Atomic Energy Commission under contract with the Union Carbide Corporation.

We are indebted to our colleagues F. G. Taylor and M. H. Shanks for assistance during the course of these experiments.

REFERENCES

1. C. F. Miller and P. D. LaRiviere, Introduction to Long-Term Biological Effects of Nuclear War, USAEC file No. NP-16462 (SRI Report MU-5779), Stanford Research Institute, April 1966.
2. J. D. Teresi and C. L. Newcombe, An Estimate of the Effects of Fallout Beta Radiation on Insects and Associated Invertebrates, Report AD-633024 (USNRDL-TR-982), Naval Radiological Defense Laboratory, Feb. 28, 1966.
3. J. P. Witherspoon and F. G. Taylor, Jr., Interception and Retention of a Simulated Fallout by Agricultural Plants, *Health Phys.*, **19**: 493-499 (1970).
4. P. W. Wong, Initial Study of the Effects of Fallout Radiation on Simple Selected Ecosystems, Report USNRDL-TR-68-11, Naval Radiological Defense Laboratory, 1967.
5. A. Broido and J. D. Teresi, Analysis of the Hazards Associated with Radioactive Fallout Material. I. Estimation of γ and β Doses, *Health Phys.*, **5**: 63-69 (1961).
6. J. E. Satchell, Lumbricidae, in *Soil Biology*, A. Burges and F. Raw (Eds.), pp. 259-322, Academic Press, Inc., New York, 1967.
7. E. F. Menhinick, ^{90}Sr Plaques for Beta Radiation Studies, *Health Phys.*, **12**: 973-979 (1966).
8. J. L. Roti Roti and S. V. Kaye, Calibration of $^{90}\text{Sr} + ^{90}\text{Y}$ Plaques for Irradiating Insects, USAEC Report ORNL-TM-1921, Oak Ridge National Laboratory, July 18, 1967.
9. J. Berkson, Estimate of the Integrated Normal Curve by Minimum Normit Chi-Square with Particle Reference to Bio-Assay, *J. Amer. Statist. Ass.*, **50**: 529-549 (1950).
10. R. L. Hancock, Lethal Doses of Irradiation for *Lumbricus*, *Life Sci.*, **1**: 625-628 (1962).
11. S. I. Auerbach, D. A. Crossley, Jr., and M. D. Engelman, Effects of Gamma Radiation on Collembola Population Growth, *Science*, **126**: 614 (1957).
12. R. V. O'Neill and C. E. Styron, Applications of Compartment Modeling Techniques to Collembola Population Studies, *Amer. Midland Natur.*, **83**: 489-495 (1970).
13. D. E. Reichle and R. I. Van Hook, Jr., Effect of Temperature and Radiation Stresses on the Survivorship of Isopods: *Armadillidium vulgare* and *Cylisticus convexus*, *Radiat. Res.*, in preparation.
14. C. A. Edwards, Effects of Gamma Irradiation on Populations of Soil Invertebrates, in Symposium on Radioecology, May 15-17, 1967, Ann Arbor, Mich., D. J. Nelson and F. C. Evans (Eds.), USAEC Report CONF-670503, pp. 68-77, AEC Division of Biology and Medicine and Ecological Society of America, March 1969.
15. M. S. Laverack, *The Physiology of Earthworms*, pp. 10-11, Pergamon Press, Inc., New York, 1963.

CESIUM-137 ACCUMULATION, DOSIMETRY, AND RADIATION EFFECTS IN COTTON RATS

D. DIGREGORIO, P. B. DUNAWAY, J. D. STORY, and J. T. KITCHINGS III*
Ecological Sciences Division, Oak Ridge National Laboratory, Oak Ridge, Tennessee

ABSTRACT

Cesium-137 accumulation, dosimetry, and radiation effects were determined in cotton rats living in their natural environment, which was contaminated with ^{137}Cs -labeled sand. Cesium-137 levels were relatively high 6 months after application of the fallout simulant but decreased as the simulant descended from the vegetation toward the ground. Radioactivity levels in organs and tissues, in general, paralleled those of the whole body. Dose rate to cotton rats paralleled radioactivity levels in the whole body. No effects on peripheral blood or body weight due to irradiation were observed in this study.

In natural environments contaminated by nuclear fallout debris, mammals receive both external and internal radiation, the latter resulting primarily from ingestion of contaminated food and fallout particles. Both internal and external radiation must be considered in determining the total dose the animal will receive. Radionuclide accumulation is important because it causes tissue irradiation in the individual animal and because each animal occupies a role in the food chain and is eventually a contaminated food source.

One of the major radionuclides in fallout is ^{137}Cs . Many studies of radionuclide cycling have demonstrated that wild mammals readily accumulate radiocesium.¹⁻³ Movement of radiocesium in the food chain was demonstrated by Hanson, Palmer, and Griffin;⁴ Pendelton et al.;⁵ and Jenkins, Monroe, and Golley,¹ who showed that predators accumulated more ^{137}Cs than did their potential prey in the same geographical area, thus showing increasing ^{137}Cs concentration at the secondary consumer levels of the food chain. Therefore, in addition to evaluating internal dose, we must determine total radionuclide

*Present address: Quality Control Department, Hardee Food Products, Cedartown, Georgia.

accumulation to predict both transfer in food chains and concentration at higher trophic levels.

Information concerning effects of acute and chronic irradiation on caged animals is abundant.⁶⁻⁸ Accumulation and excretion of radiocesium have also been studied in great detail in caged animals and human volunteers.⁹⁻¹² However, ¹³⁷Cs accumulation and effects of chronic internal and external irradiation in mammals living in natural environments have seldom been investigated under replicated conditions. This paper presents results of a study to determine effects and degree of ¹³⁷Cs accumulation in cotton rats (*Sigmodon hispidus*) living in outside enclosures contaminated with ¹³⁷Cs-labeled sand. Of primary concern were measurements of in vivo dosimetry, whole-body radioactivity, radioactivity of internal organs and tissues, radioactivity of gastrointestinal contents, and effects on the hemopoietic system.

MATERIALS AND METHODS

Study Area

In 1968 eight 100-m² enclosures were constructed in an existing fescue (*Festuca arundinacea*) community on the U. S. Atomic Energy Commission reservation, Oak Ridge, Roane County, Tenn. Each enclosure was constructed with steel sheeting buried 18 in. and standing 24 in. above ground. Geological, soil, floral, and climatological data of the area have been summarized previously.¹³ In August 1968 four of the eight enclosures were contaminated with ¹³⁷Cs-labeled silica sand particles (particle diameter, 88 to 177 μ) at a mass load of 72 g/m²; this gave a radioactivity level of 2.2 Ci per enclosure. Details of the fallout-simulant characteristics and application have been described earlier.¹⁴ Our study was conducted in four enclosures (two contaminated and two control) during the period from December 1968 to April 1970. The sides of each enclosure were topped with an electrically charged wire to contain rodents and repel nonavian predators, and each enclosure was covered with a nylon net to preclude avian predation.

Experimental Procedure

Adult, laboratory-born cotton rats were used in this study. Two weeks before being placed in the enclosures, each rat was weighed and bled to determine preexperimental values. Our hematological methods are described in detail elsewhere.¹⁵ Three to four days before rats were placed in the enclosures, two glass-rod dosimeters encased in nylon capsules were injected subcutaneously (one dorsally and one ventrally) in each rat according to the method of Kaye.¹⁶

Four animals were released into each enclosure at various times during the year and were trapped 30 days later. Sexes were kept in separate contaminated and control enclosures. In the spring and fall of 1969, half the animals trapped

at the 30-day sample were re-released into the enclosures to be recaptured for a 60-day sample. At time of capture all animals were weighed and then assayed for whole-body radioactivity in a Packard Instrument Co. Armac liquid scintillation detector, and the dosimeters were removed.

Internal organs (heart, liver, spleen, and kidneys) of the radioactive rats were weighed and counted for radioactivity in the whole-body counter. The gastrointestinal (GI) tract was excised from the terminal end of the esophagus to the anus and separated into its four components: stomach, small intestine, cecum, and large intestine. These components were cleared of contents with 1*N* sodium acetate buffer solution, weighed, and counted for radioactivity. Gastrointestinal contents were assumed to be comprised of two components, fallout simulant and organic matter, and separation of contents was based on this assumption. Contents of each GI component were triturated and washed with 30% hydrogen peroxide. Organic matter rose to the top of the hydrogen peroxide, and fallout simulant settled to the bottom. Both fallout simulant and organic matter were then counted as described.

Total in vivo gamma dosimetry from both internal and external sources was determined with Toshiba low-Z glass rods (1 by 6 mm) read on a Toshiba fluoro glass dosimeter, type FGD-38, using National Bureau of Standards standards. Internal beta dose rate (rads/day) was determined from our data by the method of Hine and Brownell,¹⁷ by using the beta and electron mean energies and mean number per disintegration from Dillman.¹⁸ It was assumed that the range of beta particles was small relative to dimensions of the cotton rat; therefore beta energy was assumed to be completely absorbed.¹⁹ Gamma-ray dose rate (rads/day) was calculated from the equation

$$D_{\gamma} = 51.2CE_t \quad (1)$$

where D_{γ} = gamma-ray dose rate

51.2 = dis/day \times g-rad/MeV

C = isotope concentration (μ Ci/g)

E_t = total gamma + X-ray energies

Photon energies were determined from Dillman,¹⁸ and absorbed fractions for photon sources were determined for a mass of about 118 g by using the data of Snyder et al.²⁰ For both internal beta- and gamma-dose-rate calculations, uniformly distributed isotope was assumed.

RESULTS AND DISCUSSION

Dosimetry

The major contribution to whole-body total dose rate was from external gamma irradiation. Amounts of external and internal irradiation contributing to

Table 1
 CONTRIBUTION OF INTERNAL AND EXTERNAL GAMMA AND INTERNAL BETA IRRADIATION
 TO THE TOTAL WHOLE-BODY DOSE RATE

Sample period	Number of animals sampled	Total dose rate (gamma + beta), rads/day	External gamma dose rate, rads/day	% of total	Internal gamma dose rate, rads/day	% of total	Internal beta dose rate, rads/day	% of total
February 1969	2	4.41	3.77	85.5	0.075	1.7	0.56	12.7
April 1969	2	3.42	3.04	88.9	0.051	1.5	0.38	11.1
May 1969	4	3.15	2.95	93.7	0.024	0.8	0.18	5.7
July 1969	6	2.72	2.54	93.4	0.021	0.8	0.16	5.9
October 1969	4	2.48	2.41	97.2	0.008	0.3	0.06	2.4
November 1969	4	2.45	2.34	95.5	0.012	0.5	0.09	3.8
January 1970	3	2.44	2.39	98.0	0.005	0.2	0.04	1.6
April 1970	6	2.62	2.57	98.1	0.005	0.2	0.04	1.6

whole-body total dose rate and to GI-tract total dose rate are shown in Tables 1 and 2. Internal beta irradiation contributed more to both the whole-body and the GI-tract total dose rates than did internal gamma irradiation because the size of the cotton rat permitted complete absorption of the beta energy but considerably less of the gamma. During the early months of the investigation,

Table 2
CONTRIBUTION OF GI-CONTENTS GAMMA AND BETA IRRADIATION TO
TOTAL GI-TRACT DOSE RATE*

Sample period	Number of animals sampled	Total dose rate (gamma + beta), rads/day	Internal beta dose rate, rads/day	Internal gamma dose rate, rads/day
February 1969	2	0.805	0.71	0.095
April 1969	2	0.555	0.49	0.065
May 1969	4	0.249	0.22	0.029
July 1969	6	0.103	0.09	0.013
October 1969	4	0.215	0.19	0.025
November 1969	4	0.181	0.16	0.021
January 1970	3	0.068	0.06	0.008
April 1970	6	0.113	0.10	0.013

*Beta contribution was 88.3% of the total and gamma contribution 11.7%.

internal beta- and gamma-irradiation contribution to the total whole-body dose rate was 12.7 and 1.7%, respectively, whereas the external gamma contribution was 85.5%. Later, however, when ^{137}Cs intake by the animals was reduced (see discussion in the following paragraphs), internal beta and gamma irradiation contributed only 1.6 and 0.2%, respectively, to the total whole-body dose rate, whereas the external gamma contribution was 98.1%. It appears that internal beta irradiation is of more consequence early after fallout arrival than it is later.

Average gamma dose rates from both external and internal sources in cotton rats ranged from 3.84 rads/day in February 1969 to 2.35 rads/day in November 1969 (Fig. 1). Regression analysis showed that from February to July the dose rates decreased 0.008 rad/day per day but from July to April 1970 there was no significant change. The initial decrease in dose rate probably was caused by changing geometry of the radiation fields in pens as the fallout simulant descended through the vegetation to the ground. Most of the fallout simulant is now on the ground, forming an irregular plane source and resulting in a relatively stable dose rate of approximately 2.46 rads/day.

Radioactivity

Radioactivity in cotton rats is shown in Fig. 2. The four measurements (whole body, total tissue, organic matter, and fallout simulant), in general,

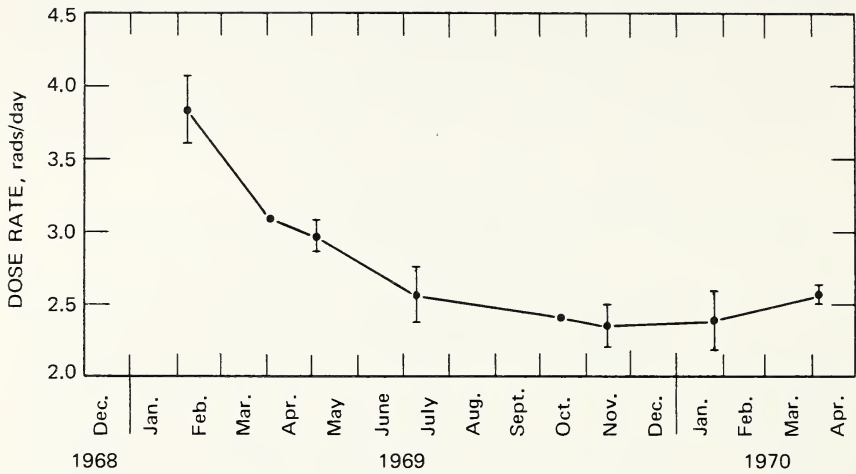

Fig. 1 Gamma dose rate to cotton rats living in ^{137}Cs -contaminated enclosures from February 1969 to April 1970. ●, means of dorsal and ventral dosimeters. Vertical lines represent standard error of the mean, and absence of vertical lines denotes standard error too small to plot.

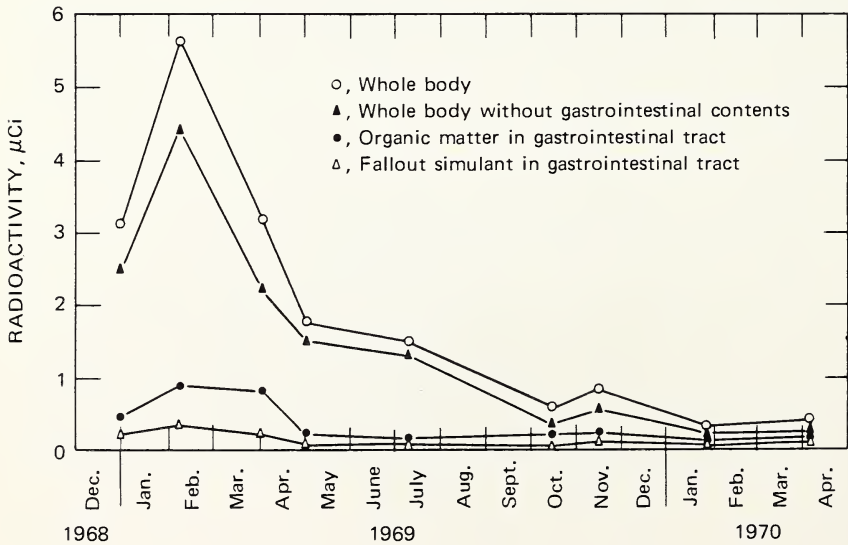

Fig. 2 Total radioactivity (μCi) in cotton rats after chronic ingestion of ^{137}Cs -contaminated fallout simulant and vegetation for 30 or 60 days.

parallel each other. Radioactivity in all four measurements increased from December 1968 to February 1969, after which time it began to decrease. This initial rise in cotton-rat whole-body radioactivity was probably influenced by relative proportions of living and dead vegetation in their diet since the choice of food in midwinter was influenced by the diminution of living vegetation. As living vegetation decreased, rats foraged closer to the ground; hence their diet consisted of increasing amounts of dead vegetation. Dahlman, Auerbach, and Dunaway¹⁴ reported that radioactivity was considerably greater in dead vegetation than in living vegetation. Therefore descent of fallout simulant to the ground, which results in its availability for ingestion, coupled with the change in food helps to explain the high whole-body radioactivity in cotton rats during midwinter 1969. As time progressed, however, radioactivity levels of living and dead vegetation approached each other; this resulted in a relatively constant body burden in cotton rats. Descent curves of these measurements parallel those of the dosimetry and, again, reflect movement of fallout simulant toward the ground. Whole-body radioactivity remained relatively constant from October 1969 to April 1970, whereas GI-content radioactivity remained relatively constant after May 1969.

Figure 3 shows relative amounts of ¹³⁷Cs in each of five compartments: internal organs, GI tissue, GI contents (organic matter and fallout simulant), pelt (skin and hair), and residual carcass. These percentages include both 30- and

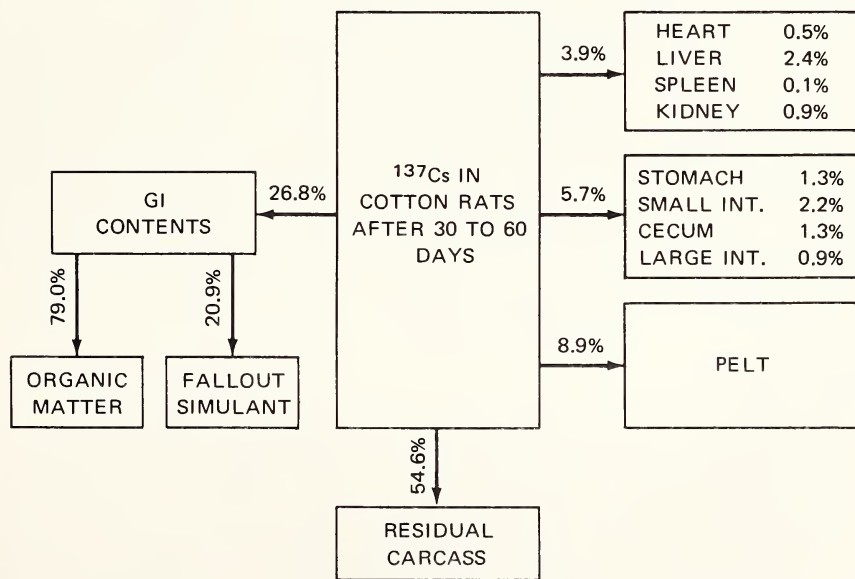

Fig. 3 Percent of radioactivity in various components of cotton rats after 30 to 60 days of chronic ingestion of ¹³⁷Cs-contaminated fallout simulant and vegetation.

60-day samples over the entire experimental period because we found no significant increase or decrease from 30 to 60 days. In December 1968, whole-body radioactivity reached a maximum level 3 weeks after animals were placed in the pens.²¹ Kitchings, Dunaway, and Story,¹² in a laboratory study, determined equilibrium at 544 hr (22.7 days) after chronically feeding cotton rats ¹³⁴Cs-tagged lettuce for 30 days. In March 1970 we trapped cotton rats 7 and 10 days after placing them in the contaminated pens. Whole-body radioactivity was 0.3620 and 0.3579 μCi , respectively. These values were not significantly different from 0.3790 μCi determined on day 30. Therefore we feel that cotton rats reached ¹³⁷Cs equilibrium by 30 days and that gain or loss would be negligible for an additional 30 days.

Radioactivity in the rats was contained mostly in the residual carcass (Fig. 3). The two major compartments of residual carcass are muscles and skeleton, which comprised about 49 and 7%, respectively, of total body wet weight.²² It is well established that ¹³⁷Cs is accumulated in muscle in much larger amounts than in any other mammalian tissue.^{9,23,24} The data in Table 3 support these findings. Pelt, which includes skin and hair, accounted for 8.9% of the whole-body radioactivity. In terms of weight most of the pelt is muscle. Because of both tissue specificity for ¹³⁷Cs and amount of muscle in the mammalian body, it is apparent that most of the body burden was contained in muscle.

Average radioactivity in cotton-rat GI-tract contents was 27% of the whole-body radioactivity. Of the total amount of radioactivity in the GI contents, 79% was in organic matter and 20.9% was in fallout simulant. The radioactivity contribution of fallout simulant in the early part of the experiment was approximately 10 times that in April 1970, our last sample period. Weathering caused leaching of ¹³⁷Cs from the fallout simulant into the native soil and onto the plants. Also, the simulant is becoming mixed with the soil. Consequently ¹³⁷Cs is still present, but it is not so readily ingestible in the form of fallout simulant. With increasing time vegetation radioactivity will reflect radioactivity levels in the soil; therefore future body burdens of herbivores and saprovores living in the contaminated areas will reflect ¹³⁷Cs levels in living and dead vegetation.

Radiation Effects

We saw no effects of the ¹³⁷Cs radiation on either body weight or peripheral blood of cotton rats. Any slight changes in body weight or general blood measurements probably were results of seasonal variations in the general environment since similar measurements were obtained for both control and experimental animals. For cotton rats general environmental fluctuations may be of more immediate consequence than low-level irradiation. Previous studies with cotton rats showed that relatively high acute doses of radiation were required to affect body weight⁸ and blood.²⁵ In January 1970 our animals were exposed to

Table 3

 RADIOACTIVITY AND WEIGHT OF COTTON-RAT ORGANS AND TISSUES AFTER 30 TO 60 DAYS OF
 CHRONIC INGESTION OF ^{137}Cs -CONTAMINATED FALLOUT SIMULANT AND VEGETATION

Sample period	Number of animals sampled	Whole body	Heart	Liver	Spleen	Kidney	Stomach	Small intestine	Cecum	Large intestine	Pelt	Muscle	Radioactivity, $\mu\text{Ci/g}$										
													Wet Weight, g*										
February 1969	2	0.0441	0.0361	0.0249	0.0482	0.0485	0.0635	0.0594	0.0510	0.0434	0.0207	0.1054											
April 1969	2	0.0298	0.0567	0.0202	0.1587	0.0479	0.0500	0.0361	0.0318	0.0440	0.0255	0.0768											
May 1969	4	0.0143	0.0142	0.0089	0.1532	0.0167	0.0200	0.0143	0.0156	0.0133	0.0080	0.0307											
July 1969	6	0.0124	0.0115	0.0065	0.0164	0.0139	0.0175	0.0165	0.0120	0.0120	0.0081	0.0232											
October 1969	4	0.0046	0.0065	0.0036	0.0071	0.0067	0.0036	0.0037	0.0035	0.0079	0.0033	0.0055											
November 1969	4	0.0068	0.0045	0.0036	0.0101	0.0067	0.0038	0.0038	0.0031	0.0029	0.0030	0.0103											
January 1970	3	0.0030	0.0029	0.0022	0.0021	0.0039	0.0033	0.0031	0.0026	0.0029	0.0017	0.0060											
April 1970	6	0.0031	0.0007	0.0011	0.0004	0.0020	0.0004	0.0006	0.0003	0.0004	0.0018	0.0032											
	31	117.1	0.5135	4.9543	0.0774	1.0412	1.2989	2.4680	1.6234	1.3199	17.9157	54.81											

* Values are mean weight of 31 animals.

several days of 0°F temperatures and precipitation. After 30 days, only three of eight experimental animals and two of eight control animals were recovered alive. Dunaway and Kaye²⁶ reported similar mortality in free-ranging cotton rats during cold weather. Percent recovery during the present study was considerably higher in favorable weather.

Ecological Significance

The degree of internal exposure from ^{137}Cs is determined ultimately by the quantity of isotope in the diet,²⁷ its absorption, and its turnover rate. If ^{137}Cs enters the diet primarily through material deposited on vegetation, internal dose will be proportional to retention of the fallout. If, however, the isotope is incorporated predominantly through the root systems of plants, the dose will be proportional to the total amount of isotope in the soil. Our results support these contentions in part. Tables 1 and 2 and Fig. 2 show the decreasing dose rate with decreasing internal radioactivity as the fallout simulant descends to the ground.

Regardless of the mechanism of incorporation of radioisotope, one of the major consequences of fallout is the creation of a contaminated food source in the food chain. Results of a study with one herbivore, the cotton rat, are presented in this paper, but contamination transfer in the ecosystem will not cease at the vegetation-cotton rat link in the food chain. Jenkins, Monroe, and Golley¹ determined trophic-level-increase ratios for the predator-prey relation involving the gray fox and the cotton rat to be 2.0 and 5.6, the latter determined from an area with "a general lack of potassium." Similarly, from their data, increase ratios for the bobcat-cotton rat relation can be determined as 6.9 and 18.7, the latter again being from the area low in potassium. Analysis of soil in our area indicated no lack of potassium.²⁸ Since the same predator-prey relations of gray fox-cotton rat and bobcat-cotton rat presumably exist in and around Oak Ridge, contamination levels can be predicted for the gray fox and the bobcat by using the increase ratio of 2.0 and 6.9, respectively. In February 1969, when radioactivity in cotton rats was highest (0.04 $\mu\text{Ci/g}$), radioactivity in gray foxes and bobcats would have been about 0.08 and 0.28 $\mu\text{Ci/g}$, respectively. In November 1969, when cotton-rat radioactivity was lowest (0.007 $\mu\text{Ci/g}$), radioactivity in gray foxes and bobcats would have been about 0.014 and 0.048 $\mu\text{Ci/g}$, respectively. During November 1969 a 7000-g gray fox could accumulate 98 μCi , and a 7000-g bobcat could accumulate 336 μCi (0.336 mCi). The body burden for the bobcat would therefore be approximately 112 times greater than the maximum permissible body burden allowed for man under occupational conditions²⁹ and even greater than that for man in the nonoccupational category.

CONCLUSIONS

Our results indicate that, for cotton rats in situations similar to ours, we could expect the following:

1. Within a 30- or 60-day time period, neither weight nor blood will be appreciably affected by chronic low-level radiation (2.44 to 4.41 rads/day) from ^{137}Cs . Changes in these measurements will be caused by changes in environmental factors, such as temperature.

2. Radioactivity levels for whole body, tissues, and GI contents will, in general, parallel each other. Approximately 1 year after fallout arrives, whole-body radioactivity will be only about one-tenth that of early levels but will remain at this lower level for a long period, perhaps years.

3. Such internal organs as heart, liver, spleen, and kidneys will accumulate a relatively small amount of ^{137}Cs .

4. Most of the accumulated ^{137}Cs in tissue will be in muscle because of the relatively high affinity of ^{137}Cs for muscle and the large proportion of muscle in the body.

5. For the first 6 to 12 months after arrival of fallout, dose rate will decrease rather sharply. After this initial decrease equilibrium will be reached and dose rate decrease will be negligible.

6. Although there may be seasonal fluctuations in dosimetry and whole-body radioactivity levels, they will probably be slight.

ACKNOWLEDGMENTS

This research was sponsored by the Office of Civil Defense and the U. S. Atomic Energy Commission under contract with the Union Carbide Corporation.

We gratefully acknowledge the competent assistance of our colleague L. E. Tucker, without whose help this investigation would have been very laborious. Special gratitude is expressed to W. S. Snyder and Mary R. Ford of the Health Physics Division, Oak Ridge National Laboratory, for their help with internal-dose calculations.

REFERENCES

1. J. H. Jenkins, J. R. Monroe, and F. B. Golley, Comparison of Fallout ^{137}Cs Accumulation and Excretion in Certain Southeastern Mammals, in Symposium on Radioecology, May 15-17, 1967, Ann Arbor, Mich., D. J. Nelson and F. C. Evans (Eds.), USAEC Report CONF-670503, pp. 623-626, AEC Division of Biology and Medicine and Ecological Society of America, March 1969.
2. G. L. Plummer, T. M. Pullen, Jr., and E. E. Provost, Cesium-137 and a Population of Georgia White-Tailed Deer, in Symposium on Radioecology, May 15-17, 1967, Ann Arbor, Mich., D. J. Nelson and F. C. Evans (Eds.), USAEC Report CONF-670503, pp. 609-615, AEC Division of Biology and Medicine and Ecological Society of America, March 1969.
3. S. V. Kaye and P. B. Dunaway, Estimation of Dose Rate and Equilibrium State from Bioaccumulation of Radionuclides by Mammals, in *Radioecology*, Proceedings of the First National Symposium, Sept. 10-15, 1961, Fort Collins, Colo., V. Schultz and

- A. W. Klement, Jr. (Eds.), pp. 77–111, Reinhold Publishing Corporation, New York, 1963.
4. W. C. Hanson, H. E. Palmer, and B. I. Griffin, Radioactivity in Northern Alaskan Eskimos and Their Foods, Summer 1962, *Health Phys.*, **10**: 421–429 (1964).
 5. R. C. Pendelton, C. W. Mays, R. D. Lloyd, and B. W. Church, A Trophic Level Effect on ^{137}Cs Concentration, *Health Phys.*, **11**: 1503–1510 (1965).
 6. V. P. Bond et al., *Mammalian Radiation Letbality: A Disturbance in Cellular Kinetics*, pp. 106–110, Academic Press, Inc., New York, 1965.
 7. E. H. Betz, Chronic Radiation Effects: Damage of Hematopoiesis, in *Nuclear Hematology*, E. Szirmai (Ed.), pp. 357–377, Academic Press, Inc., New York, 1965.
 8. P. B. Dunaway, L. L. Lewis, J. D. Story, J. A. Payne, and J. M. Inglis, Radiation Effects in the Soricidae, Cricetidae, and Muridae, in Symposium on Radioecology, May 15–17, 1967, Ann Arbor, Mich., D. J. Nelson and F. C. Evans (Eds.), USAEC Report CONF-670503, pp. 173–184, AEC Division of Biology and Medicine and Ecological Society of America, March 1969.
 9. S. L. Hood and C. L. Comar, Metabolism of Cesium-137 in Rats and Farm Animals, *Arch. Biochem. Biophys.*, **45**(2): 423–433 (1953).
 10. G. V. LeRoy, J. H. Rust, and R. J. Hasterlik, The Consequences of Ingestion by Man of Real and Simulated Fallout, USAEC Report ACRH-102, Argonne Cancer Research Hospital.
 11. T. E. Hakonson and F. W. Whicker, Uptake and Elimination of ^{134}Cs by Mule Deer, in Symposium on Radioecology, May 15–17, 1967, Ann Arbor, Mich., D. J. Nelson and F. C. Evans (Eds.), USAEC Report CONF-670503, pp. 616–622, AEC Division of Biology and Medicine and Ecological Society of America, March 1969.
 12. J. T. Kitchings III, P. B. Dunaway, and J. D. Story, Uptake and Excretion of ^{134}Cs from Fallout Simulant and Vegetation by Cotton Rats, *Health Phys.*, **17**: 265–277 (1969).
 13. J. M. Kelly, P. A. Opstrup, J. S. Olson, S. I. Auerbach, and G. M. Van Dyne, Models of Seasonal Primary Productivity in Eastern Tennessee *Festuca* and *Andropogon* ecosystems, USAEC Report ORNL-4310, Oak Ridge National Laboratory, June 1969.
 14. R. C. Dahlgren, S. I. Auerbach, and P. B. Dunaway, Behavior of ^{137}Cs -Tagged Particles in a Fescue Meadow, in *Environmental Contamination by Radioactive Materials*, Seminar Proceedings, Vienna, 1969, pp. 153–165, International Atomic Energy Agency, Vienna, 1969 (STI/PUB/226).
 15. L. L. Lewis and P. B. Dunaway, Techniques for Hematological Studies of Wild Mammals, USAEC Report ORNL-3806, Oak Ridge National Laboratory, June 1965.
 16. S. V. Kaye, Use of Miniature Glass Rod Dosimeters in Radiation Ecology, *Ecology*, **46**(1 and 2): 201–206 (1965).
 17. G. J. Hine and G. L. Brownell (Eds.), *Radiation Dosimetry*, p. 824, Academic Press, Inc., New York, 1956.
 18. L. T. Dillman, Radionuclide Decay Schemes and Nuclear Parameters for Use in Radiation-Dose Estimates, *J. Nucl. Med.*, **10**(Suppl. No. 2): 7–32 (1969).
 19. H. L. Fisher, Jr., and W. S. Snyder, Variation of Dose Delivered by ^{137}Cs as a Function of Body Size from Infancy to Adulthood, in Health Physics Division Annual Progress Report for Period Ending July 31, 1966, USAEC Report ORNL-4007, pp. 221–228, Oak Ridge National Laboratory, October 1966.
 20. W. S. Snyder, M. R. Ford, G. G. Warner, and H. L. Fisher, Jr., Estimates of Absorbed Fractions for Monoenergetic Photon Sources Uniformly Distributed in Various Organs of a Heterogeneous Phantom, *J. Nucl. Med.*, **10**(Suppl. No. 3): 7–52 (1969).
 21. P. B. Dunaway, J. T. Kitchings III, J. D. Story, and L. E. Tucker, Mammal Studies in Field Enclosures, in Health Physics Division Annual Progress Report for Period Ending

- July 31, 1969, USAEC Report ORNL-4446, pp. 48-50, Oak Ridge National Laboratory, October 1969.
22. T. P. O'Farrell, S. I. Auerbach, and P. B. Dunaway, Incorporation of a Thymidine Analog by Indigenous Rodents, USAEC Report ORNL-3907, Oak Ridge National Laboratory, March 1966.
 23. J. G. Hamilton, The Metabolism of Fission Products and the Heaviest Elements, *Radiology*, 49: 325-343 (1947).
 24. J. G. Kereiakes, D. D. Ulmer, A. T. Krebs, and T. D. Sterling, Cesium-137 Retention and Distribution in X-Irradiated Rats, Report AMRL-504, U. S. Army Medical Research Laboratory, Sept. 4, 1961.
 25. J. T. Kitchings III, P. B. Dunaway, and J. D. Story, Blood Changes in Irradiated Cotton Rats and Rice Rats, *Radiat. Res.*, 42(2): 331-352 (1970).
 26. P. B. Dunaway and S. V. Kaye, Cotton Rat Mortality During Severe Winter, *J. Mamm.*, 42(2): 265-268 (1961).
 27. Samuel Glasstone (Ed.), The Effects of Nuclear Weapons, USAEC Report ACCESS-127, pp. 611-612, Defense Atomic Support Agency, 1962.
 28. R. C. Dahlman, Ecological Sciences Division, Oak Ridge National Laboratory, personal communication, 1970.
 29. Recommendations of International Commission on Radiological Protection, Report of Committee II on Permissible Dose for Internal Radiation, ICRP Publication 2, 1959.

THE SIGNIFICANCE OF LONG-LIVED NUCLIDES AFTER A NUCLEAR WAR

R. SCOTT RUSSELL, B. O. BARTLETT, and R. S. BRUCE

Agricultural Research Council, Letcombe Laboratory, Wantage, Berkshire, England

ABSTRACT

The radiation doses from the long-lived nuclides ^{90}Sr and ^{137}Cs , to which the surviving population might be exposed after a nuclear war, are considered using a new evaluation of the transfer of ^{90}Sr into food chains.

As an example, it is estimated that, in an area where the initial deposit of near-in fallout delivered 100 R/hr at 1 hr and there was subsequent worldwide fallout from 5000 Mt of fission, the dose commitment would be about 2 rads to the bone marrow of the population and 1 rad to the whole body. Worldwide fallout would be responsible for the major part of these doses.

In view of the possible magnitude of the doses from long-lived nuclides, the small degree of protection that could be provided against them, and the considerable strain any such attempt would impose on the resources of the community, it seems unrealistic to consider remedial measures against doses of this magnitude. Civil-defense measures should be directed at mitigating the considerably higher doses that short-lived nuclides would cause in the early period.

It is now widely recognized that long-lived fission products would make a negligible contribution to the radiation exposure of the population in heavily contaminated areas shortly after a nuclear attack. The external radiation dose would usually be dominant, and, if simple precautions were taken to avoid the superficial contamination of foodstuffs, the entry of ^{131}I into milk would cause the only important problem of dietary contamination. Thus, for example, infants probably would not receive doses of more than 0.1 rad to bone marrow from ^{90}Sr nor more than 0.01 rad from ^{137}Cs in the weeks after a nuclear attack if they were fed continuously with milk produced in an area where the external dose rate at 1 hr after detonation had been 100 R/hr. Doses to the thyroid from ^{131}I might, however, exceed 200 rads.¹ Considerably higher doses from dietary contamination were expected until it became evident that the

physical properties of near-in fallout much reduce the entry of radioactivity into food chains.

In more lightly contaminated areas, especially where deposition does not occur for many hours or days, internal radiation would give rise to a larger fraction of the total radiation dose, partly because short-lived nuclides would have decayed before fallout descended and partly because fission products contained in the more finely divided and soluble distant fallout enter food chains more readily. The relative contributions of ^{131}I , ^{90}Sr , and ^{137}Cs to the internal radiation dose would, however, be comparable to those in near-in localities.

Civil defense planning is naturally concerned primarily with this early period when external radiation is dominant, but this is not the whole story. Years after a nuclear war, long-lived nuclides will remain in the soil and will continue to descend in worldwide fallout. Therefore two questions are relevant: (1) What radiation doses will be received from these sources by the survivors of a nuclear war? (2) Is it prudent and realistic to prepare plans for long-term remedial action against the contamination of agricultural produce? This paper discusses these questions in relation to dietary contamination.

For obvious reasons the long-term problems will be caused largely by ^{90}Sr , the extent to which it will enter food chains from the soil many years after deposition being a question of major relevance. It is therefore appropriate to review information on this question in some detail.

ENTRY OF ^{90}Sr INTO FOOD CHAINS FROM THE SOIL

Our understanding of the behavior of ^{90}Sr in the soil has been much aided by experiments in which weapon debris or measured quantities of ^{85}Sr , ^{89}Sr , or ^{90}Sr have been incorporated into the soil, but quantitative relations that can be confidently applied to wide areas cannot be obtained from these small-scale studies. The best approach is to analyze the results of surveys of deposition of worldwide fallout and contamination of foodstuffs, thus partitioning the contamination of food between direct contamination (i.e., the retention of the recent deposits on vegetation) and that resulting from uptake from the soil. Many of the uncertainties that arise in extrapolating from limited data are thus avoided.

The first analysis of this type was made at the initiative of Tajima by the United Nations Scientific Committee on the Effects of Atomic Radiation² (UNSCEAR) in 1958. Like most subsequent studies, his work was concerned with the contamination of milk, because of its importance in the transfer of ^{90}Sr to human diet. Using the available survey data on the contamination of milk and the deposition of fallout, he attempted to solve simple empirical equations of the following type:

$$C = p_r F_r + p_d F_d \quad (1)$$

where C = annual mean ratio of ^{90}Sr to calcium in milk ($\text{pCi } ^{90}\text{Sr/g Ca}$)

F_r = deposit of ^{90}Sr in the year in question (mCi/km^2)

F_d = cumulative total deposit after allowance for radioactive decay
(mCi/km^2)

p_r, p_d = proportionality factors

Our discussion of the use of this and other procedures is concerned mainly with relations in the United Kingdom, but, as will be shown later, the situation there seems relatively typical of temperate regions. From survey data up to 1961, p_r and p_d were estimated to be 0.76 and 0.19 (Ref. 3). Annual milk levels calculated on this basis for past years agreed reasonably with those observed (Fig. 1b), but the defects of Eq. 1 were nonetheless obvious. First, the equation assumed that all ^{90}Sr entering milk which was not attributable to the entrapment of the current deposit on vegetation came from the cumulative total in the soil, whereas it was evident from agricultural considerations that the direct entrapment of ^{90}Sr on vegetation in the previous year must make an appreciable contribution (the "lag-rate" effect). Second, the assumption that a constant fraction of the cumulative deposit in the soil enters plants each year was clearly incorrect because of the mechanisms (to which further reference is made later) which either remove it from the rooting zone or otherwise reduce its accessibility to plants.

Refinement to take account of these two defects was, however, impossible until more-extensive survey data were assembled. This was particularly true with respect to the second defect, since a reliable estimate of the manner in which p_d decreased with time could be expected only when ^{90}Sr that had been deposited in soil for many years contributed a major fraction of the contamination in milk. In the early years the direct contamination of vegetation was the dominant source of ^{90}Sr in diet. Accordingly, in long-term assessments it was at first necessary to assume a factor by which uptake from the soil decreased annually. The value of 2%, chosen by UNSCEAR in its first assessment of dose commitments from worldwide fallout,⁴ was retained in the most recent assessment.⁵ No factual justification for the use of this value has been advanced, however.

By the end of 1964, sufficient survey data existed to make possible some revision of Eq. 1. A marked lag effect of fallout in the previous year was implied by the fact that Eq. 1 led to an overestimate of the contamination of milk when the fallout at that time was low; the reverse was true when fallout was high (Fig. 1b). An improved but still empirical equation gave a significantly better fit to the data:³

$$C = p_r F_r + p_l F_l + p_d F_d \quad (2)$$

The symbols are the same as those in Eq. 1, except that F_l represents the deposit in the last half of the previous year and p_l the lag-rate proportionality factor.

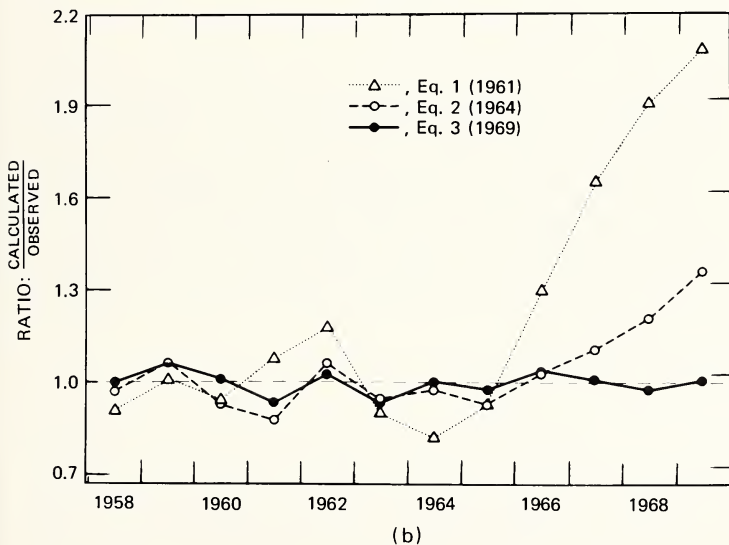
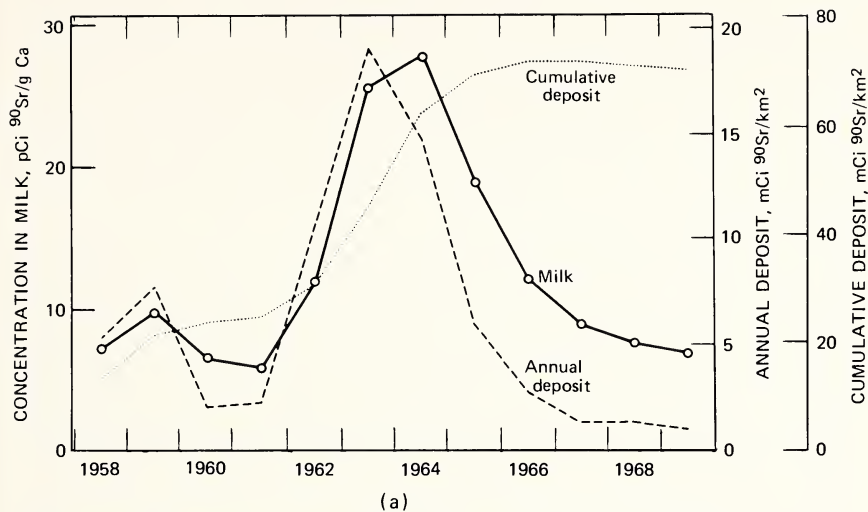

Fig. 1 Strontium-90 in fallout and milk in the United Kingdom, 1958 to 1969. (a) Mean results of surveys of deposition and contamination in milk conducted by the Atomic Energy Research Establishment, Harwell,^{3,1} and Letcombe Laboratory,^{3,2} respectively. (b) Annual average ratios of ⁹⁰Sr to calcium in milk calculated by alternative equations and expressed relative to observed values. Dates in parentheses indicate the most recent information available when the proportionality factors for the equation were derived.

This lag effect was found to be more closely related to the deposit in the last half of the previous year than to that in the whole year or in the summer months only. The following values for the proportionality factors were derived from survey data up to 1964: $p_r = 0.70$, $p_1 = 1.13$, and $p_d = 0.11$. The annual average milk levels calculated in this manner not only agreed with those observed within 8% but also remained in equally good agreement in the two subsequent years (Fig. 1b), i.e., until 1966. Thereafter, however, when the rate of fallout was low and the cumulative deposit became the dominant source of contamination, the concentration in milk was consistently and increasingly overestimated. This defect was still more obvious with Eq. 1.

Therefore, as anticipated, p_d was apparently decreasing with time after the entry of ^{90}Sr into the soil. Revised calculations by both equations with the use of survey data up to 1969 gave lower values for p_d than had been derived when results for the earlier years only were available. However, the appropriate procedure was clearly to expand the third term of Eq. 2 to take account of the progressive reduction of p_d with time after deposition. The data being insufficient to permit the estimation of independent values for each preceding year, an exponential decrease in uptake from the soil was assumed:⁶

$$C = p_1 F_1 + p_2 F_{2b} + p_3 (s^{1.25} F_{2a} + s^2 F_3 + s^3 F_4 \dots) \quad (3)$$

where C = annual ratio of ^{90}Sr to calcium in milk (pCi ^{90}Sr /g Ca) in the current year (here designated year 1)

F_1, F_2, F_3, \dots = deposits of ^{90}Sr in year 1 and each previous year after correction for decay to midpoint of year (mCi/km²)

a, b = first and second halves of year 2, respectively

s = reduction factor by which the uptake of ^{90}Sr from soil decreases annually through processes other than the decay of radioactivity

p_1, p_2, p_3 = proportionality factors

The first two terms on the right-hand side of the equation are similar to those in Eq. 2 but are not identical since they reflect the total effect of fallout, including the small contribution of uptake from the soil at the times in question, whereas in Eq. 2 uptake from the soil throughout the entire period is included in the third term. Simplifying Eq. 3 by considering F_2 as a whole was attempted, but a poorer fit to the data was obtained. This is in accord with the observation in the derivation of Eq. 2 that the lag-rate factor operated predominantly in the second half of the previous year.

The values of the coefficients in Eq. 3 derived from survey data up to 1969 are $p_1 = 0.70$, $p_2 = 1.41$, $p_3 = 0.20$, and $s = 0.86$. As shown in Fig. 1b, the content of ^{90}Sr in milk calculated on this basis agreed reasonably with that observed for each year between 1958 and 1969. Though still empirical, Eq. 3

describes the relation between the deposition of fallout and the contamination of milk considerably better than Eqs. 1 and 2; further improvement must await the availability of survey data for a longer period.

From the viewpoint of predicting dietary contamination over long periods, the particular advantage of Eq. 3 is that it provides an objective basis for estimating the extent to which the uptake of ^{90}Sr from the soil changes with time and thus dispenses with the need to make arbitrary assumptions. The value of 0.86 for s indicates a decrease by some 14% annually after allowance has been made for the decay of radioactivity. This value is in surprising agreement with the findings of Van der Stricht et al.,⁷ who, applying a different type of analysis to survey results from Ispra in northern Italy, deduced an annual reduction in uptake from the soil by about 13%. These values are considerably higher than 2%, the value assumed by UNSCEAR,⁴ but it had long been evident that in some circumstances 2% was a gross underestimate. United Kingdom experiments showed that pasture grasses can remove 2 to 5% of recently introduced ^{90}Sr from soil in a single summer.⁸ Beyond this the downward movement of ^{90}Sr in the soil by only a few centimeters will frequently cause an appreciable reduction in absorption since the roots of pasture plants draw nutrients largely from the upper soil layers.⁹ Strontium-90, like calcium, can be leached to greater depths in the soil, and in some soils physicochemical changes may bring about a small reduction in uptake by plants.¹⁰ All these processes operate conjointly, and the value of s now derived does not appear to conflict with any known facts. Note that, in addition to demonstrating a more rapid decrease in uptake of ^{90}Sr from the soil, Eq. 3 also indicates that absorption from this source is initially appreciably higher than was previously inferred. The value for p_3 is 0.20, whereas according to Eq. 2 p_d was estimated to be 0.11.

The limitations of the present analysis should be recognized, however. The time of year when fallout descends is likely to have an appreciable effect, especially in the first year, and no account can yet be taken of this fact. Furthermore, although exponential decrease in uptake from the soil has been assumed, there may be appreciable and as yet undetected changes in s with time; in particular, it is possible that this rate of change in the uptake of ^{90}Sr will slow down when ^{90}Sr has been present in soil for a longer period. Nonetheless, since Eq. 3 describes closely the situations in 1968 and 1969 (see Fig. 1), when the mean interval since the deposition of ^{90}Sr was 6 to 7 years, any eventual change in s should not have a large effect on the calculation of integrated doses.

Table 1 shows how improved calculations have modified estimates of the integrated total of ^{90}Sr that would enter milk in the United Kingdom from a given deposit. In the calculations using Eqs. 1 and 2 the UNSCEAR⁵ value of 2% per annum decrease in uptake from the soil was assumed; no such assumption is required with Eq. 3. The earliest calculation (Eq. 1) appears to overestimate the integrated contamination of milk by a factor of about 2. This undoubtedly results largely from the assumption of only 2% annual reduction in uptake from

Table 1
ESTIMATES OF THE INTEGRATED TOTAL OF
 ^{90}Sr ENTERING MILK IN THE UNITED
KINGDOM AFTER DEPOSITION OF
 $1 \text{ mCi } ^{90}\text{Sr}/\text{km}^2$

Method*	Integrated contamination of milk, $\text{pCi } ^{90}\text{Sr year/g Ca}$	Fraction attributable to uptake from soil
Equation 1 (1961)	4.9	0.84
Equation 2 (1964)	3.6	0.65
Equation 3 (1969)	2.3	0.47

*The dates in parentheses indicate the most recent data available when the calculation was made. With Eqs. 1 and 2, a 2% annual reduction in uptake from the soil is assumed following UNSCEAR;⁵ no such assumption is needed with Eq. 3.

the soil; if a 5% reduction had been assumed, the integrated total derived by Eq. 1 would have been reduced by more than 30%. Therefore estimates of dose commitments from ^{90}Sr could have little quantitative validity until an objective basis was available for estimating the manner in which absorption from the soil would decrease with time. This comment implies no criticism of UNSCEAR for having assumed a considerably slower reduction in the uptake of ^{90}Sr from the soil than is now suggested. When information is lacking, the only safeguard against underestimating risk is to adopt cautious postulates, but the uncertainty they introduce must be remembered.

Unfortunately information on the transfer of ^{90}Sr to food chains, of the type provided by Eq. 3 for the United Kingdom, is not available for the majority of countries. Thus we must consider whether the relations derived for the United Kingdom by Eq. 3 are a reasonable guide to the general situation in other temperate regions. Here UNSCEAR⁵ helps. Its tabulation of milk levels from 14 localities in the North Temperate Zone between 1955 and 1967 shows that the year-to-year trends in the United Kingdom were very close to the average (Fig. 2), the correlation coefficient being 0.99. The integrated total for the United Kingdom was about 10% higher (United Kingdom, 151 pCi year/g Ca ; average, 137 pCi year/g Ca). Accordingly, for lack of better data, the United Kingdom relations for milk (derived by Eq. 3) will be assumed to be approximately representative of the average situation in other temperate countries until a more nearly complete assessment becomes available.

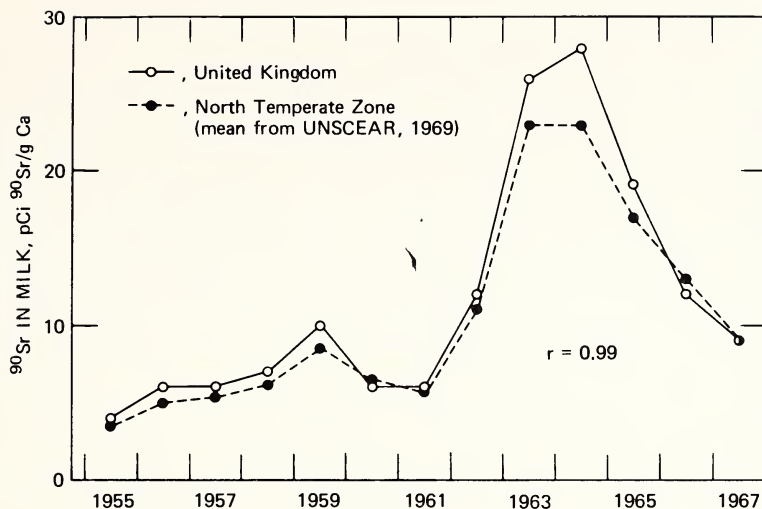

Fig. 2 Comparison of the annual average ratios of ^{90}Sr to calcium in milk in the United Kingdom with the mean values derived by UNSCEAR⁵ for the North Temperate Zone.

RADIATION DOSES FROM LONG-LIVED FISSION PRODUCTS IN DIET AFTER A NUCLEAR WAR

Long-lived fission products from both the initial near-in deposit and the subsequent worldwide fallout will expose the survivors of a nuclear war to radiation. To illustrate problems that might arise, we will consider the situation in an area receiving an external radiation dose of 100 R/hr from early fallout 1 hr after the detonation of a weapon (the total amount of fission occurring in the entire war being 5000 Mt). From this model it is easy to scale upward or downward to any preferred case.

Attention is confined to doses received after sufficient time has elapsed for the contribution from short-lived fission products to be insignificant, for agricultural production to be resumed, and for dietary contamination from worldwide fallout to have reached its peak. For convenience, the 12-month period when this situation is attained is described as "postwar year 1," but we must realize that the length of time before this occurs could vary appreciably depending on many factors; it would not be likely to exceed 2 years, however. Since doses from long-lived fission products received before postwar year 1 would be small relative to the integrated total dose thereafter, little error is introduced by ignoring the earlier period.

Dose from ^{90}Sr

Assumptions on the composition of fission products, on the relation between deposition and external gamma radiation dose, and on fractionation, summarized in Appendix A, indicate that near-in fallout would deposit approximately 1000 mCi of ^{90}Sr per square kilometer in a fallout field of 100 R/hr at 1 hr. The large particle size of the debris will undoubtedly lower its solubility by a considerable factor, but, pessimistically, 500 mCi of ^{90}Sr per square kilometer is assumed to be present in forms accessible to plant roots in postwar year 1. The results of surveys of worldwide fallout combined with estimates of the quantity of nuclear fission released by nuclear tests, which are reviewed in Appendix B, suggest that 5000 Mt of fission would give rise to a deposit of about 1100 mCi of ^{90}Sr per square kilometer in the first year, with a half-residence time in the atmosphere of about 12 months; these estimates refer to temperate latitudes in the hemisphere where detonation occurred.

Applying the coefficients derived earlier for Eq. 3, we can derive the levels of ^{90}Sr in milk caused by the initial deposit and by worldwide fallout. These values, along with the fraction of the total contamination attributable to absorption from the soil in each year, are shown in Table 2.

Table 2
CONTAMINATION OF MILK WITH ^{90}Sr AFTER A NUCLEAR WAR*

Years postwar	Contamination of milk, pCi $^{90}\text{Sr}/\text{g Ca}$					Fraction attributable to soil
	Direct contamination of plants with worldwide fallout	Uptake from soil		Total		
		Worldwide fallout	Near-in deposit			
1	1150	85	100	1340	0.14	
2	570	200	85	860	0.33	
3	290	230	72	590	0.52	
4	140	230	60	430	0.67	
5	72	210	50	330	0.78	
6	36	180	42	260	0.86	
7	18	160	35	210	0.91	
8	9	130	30	170	0.95	
9	4	110	25	140	0.97	
10	2	95	21	120	0.98	
Total						
Years 1 to 10	2290	1630	520	4450	0.48	
Years 1 to ∞	2290	2130	630	5060	0.55	

*For the calculations it is assumed that near-in fallout delivered 100 R/hr at 1 hr and that total fission in the hemisphere is 5000 Mt.

It is now widely recognized that, because of the risk of leukemia, the radiation dose to bone marrow is the appropriate basis for assessing risks from ^{90}Sr . To estimate the highest dose to this tissue which any individual could receive annually, we have assumed that the entire bone of infants in the first year of life is in equilibrium with diet each year, that the ratio of ^{90}Sr to calcium in their bone is 0.25 of that in the diet, and that 1 pCi $^{90}\text{Sr}/\text{g Ca}$ in bone will deliver 0.82 mrad/year to bone marrow.¹¹ On this basis, infants in their first year will receive the radiation doses shown in Fig. 3. In postwar year 1 the doses to bone marrow would be about 0.25 rad/year. Over the next few years the dose would decrease relatively rapidly to about 0.1 rad/year in the fourth year and about 0.03 rad/year after 10 years.

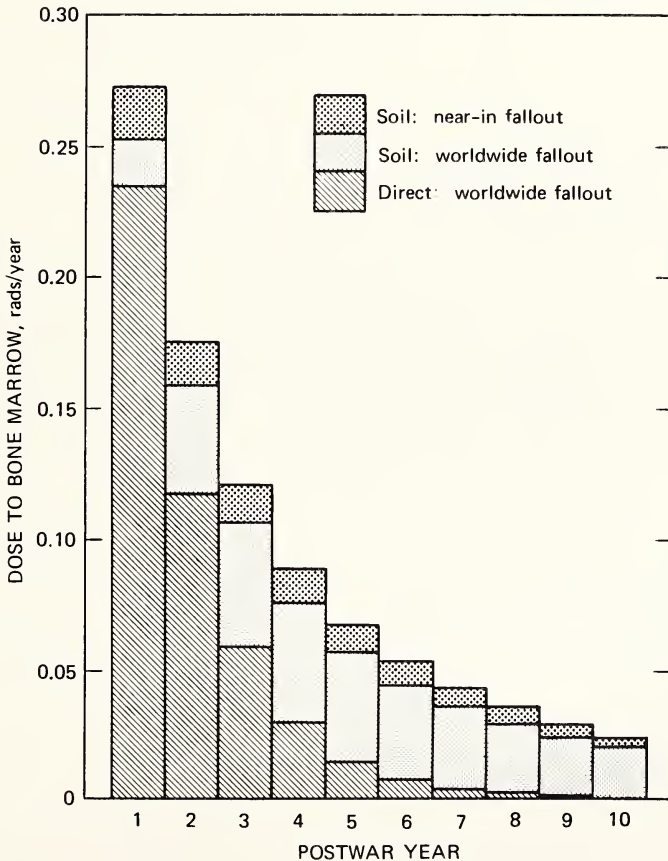

Fig. 3 Estimates of the radiation doses from ^{90}Sr to bone marrow which might be received in the first year of life by infants born during the decade after a nuclear war (for assumptions, see text).

Alternatively, the dose commitment to the population can be estimated by using the procedure of UNSCEAR.⁵ In this calculation it is necessary to assume the relation between the ratio of ^{90}Sr to calcium in the total diet and that in milk. In the majority of countries where these ratios have been examined, the ratio in the total diet is 1 to 1.5 times that in milk. In the present calculation the higher (pessimistic) value of 1.5 was used. On this basis, the dose commitment from ^{90}Sr is about 1 rad, nearly all of which is received in the first 10 years (Table 3).

Table 3
DOSE COMMITMENT FROM ^{90}Sr TO BONE
MARROW AFTER A NUCLEAR WAR*

Source	Dose to bone marrow, rads	
	Years postwar	
	1 to 10	1 to ∞
Worldwide fallout		
Direct contamination	0.38	0.38
Uptake from soil	0.27	0.35
Early fallout		
Uptake from soil	0.08	0.10
Total	0.73	0.83

*For the calculations it is assumed that near-in fallout delivered 100 R/hr at 1 hr and that total fission in the hemisphere is 5000 Mt.

Some 90% of the total dose commitment would come from worldwide fallout, the early fallout in an area where the external gamma dose was 100 R/hr at 1 hr contributing only a minor fraction of the total. This latter component could be scaled up to take account of situations in areas of much higher initial contamination. This would almost certainly be unrealistic, however, since the large particle size of the deposits in such areas would usually contain relatively insoluble fission products, whereas 50% solubility has been assumed in the present calculations. An appreciably larger contribution from this source might result, however, if the plumes from several weapons overlapped.

Dose from ^{137}Cs

So far we have considered doses from ^{90}Sr only. Cesium-137 must also be taken into account. Assessment of doses from this nuclide might be thought to be much simpler than that of doses from ^{90}Sr since, as is well known, the fixation of ^{137}Cs in clay minerals causes it to enter food chains to only a very small extent a year or two after deposition. Unfortunately, however, the basis

for estimating doses from ^{137}Cs is less certain than that for ^{90}Sr , partly because, even though this discussion is concerned primarily with dietary contamination, it is logical to consider external as well as internal exposure from this nuclide and partly because its behavior cannot be related so precisely to that of a widely studied stable element as can that of strontium. However, the paucity of information regarding ^{137}Cs must be attributed largely to the fact that, when worldwide fallout first received notice, the isotopes of strontium were the dominant if not the sole preoccupation of many workers in this field. Such data as are available now have been reviewed by UNSCEAR.⁵ The dose commitment to the bone marrow of the population from ^{137}Cs in worldwide fallout appears to be about 90% of that from ^{90}Sr , the same dose from ^{137}Cs being received by all tissues, of course. Within the limits of accuracy practicable in the present discussion, we may therefore assume that the dose commitment from ^{137}Cs to all tissues after the postulated war would be similar to that from ^{90}Sr to the bone marrow, i.e., about 1 rad.

The Total Dose

For present purposes it is unnecessary to consider nuclides other than ^{90}Sr and ^{137}Cs . Other fission products will be trivial sources of dietary contamination, and ^{14}C can be ignored because it would deliver considerably smaller annual doses in the decades following the war and because there is no prospect of influencing its transfer from the atmosphere into food chains.

Accordingly we may conclude that, after a nuclear war involving 5000 Mt of fission, the dose commitment from ^{90}Sr and ^{137}Cs to the inhabitants of the hemisphere in which the war took place would be approximately 2 rads to the bone marrow and 1 rad to the whole body from long-lived nuclides. For persons living near the target area, the doses would be only slightly higher than the average.

DISCUSSION

This assessment is, of course, approximate, but it may assist in a more realistic appraisal of the problems to which long-lived nuclides might give rise in the decades following a nuclear war. Even when the maximum allowance is made for uncertainties, the following facts are evident:

1. Doses from long-lived nuclides will be trivial relative to those received from short-lived activities in the earlier period in areas of appreciable near-in fallout.

2. Assuming that a nuclear war is of considerable magnitude (5000 Mt is in this category), worldwide fallout and not near-in debris would usually be the dominant source of dietary contamination with long-lived nuclides.

3. The direct contamination of growing crops is likely to be responsible for about half the dietary contamination with ^{90}Sr .

This last conclusion should not cause surprise. It is now over a decade since unequivocal evidence became available^{1,2} that in times of relatively high fallout the direct contamination of plants and not, as it was first suggested, absorption from the soil was the major route by which ^{90}Sr entered diet. Implicit also in the analyses that could be made at that time was the fact that the average extent to which ^{90}Sr would enter plants from the soil over a long period was likely to be overestimated, but by a factor that could not be suggested until investigations had continued for a much longer period. That stage has now been reached. If the soil were low in calcium, the ^{90}Sr contribution could be greater than is suggested here. However, in a survival situation the need to achieve the maximum food production would probably be the most cogent reason to remedy such situations (If sufficient calcium is present in soil for good crop growth, uptake of ^{90}Sr from the soil should not be appreciably greater than the average.)

So far this discussion has been concerned with the first question posed at the beginning of this paper, namely, "What radiation doses would long-lived nuclides portend after a nuclear war?" Now we will turn to the second question: "Is it prudent and realistic to prepare plans for long-term remedial action?" The literature contains numerous suggestions for modifying the transfer of fission products through food chains, but unfortunately the majority of them do not relate to situations likely to arise in practice.

A quarter or more of the casualties from long-lived nuclides after a nuclear war would apparently be due to external radiation from ^{137}Cs ; this risk could not be mitigated over a wide area by any practicable method. Reduction of the average level of radioactivity in agricultural produce by a large factor also seems impossible. Figure 3 shows that, during the early years when doses would be highest, the major part of the internal dose from ^{90}Sr and, of course, almost the entire internal dose from ^{137}Cs comes from entrapment of the deposit on growing plants. Under normal agricultural conditions, reducing direct contamination of crops without destroying them would be impossible. Since we are unable to prevent either nuclide from entering the food chain, can we do anything to reduce transfer to man? The decontamination of milk has been widely discussed. Since milk products in all forms make a large contribution to the total contamination of diet, in round terms about half the dose commitment from ^{90}Sr and less than half the internal dose from ^{137}Cs could be spared by decontamination of the total milk supply. At one time it was imagined that this procedure would give greater protection to infants, especially from ^{90}Sr , than to adults, but, when it was recognized that ^{90}Sr is rapidly eliminated from the bones of the young,¹³ it became evident that the benefit was much smaller.

Some other possible remedial measures have been suggested. When diets are low in calcium, the addition of that element reduces the retention of ^{90}Sr in the body, but increasing the calcium intake above that common in many western diets gives little benefit. Various therapeutic treatments have been discussed,

but, since the risks from the therapy may be comparable to those from the anticipated radiation doses, the treatments cannot be considered seriously. Modification of the composition of diet, which has been suggested, would, in general, have no great effect if conventional methods of agricultural production were retained. Unfortunately the discrimination against strontium relative to calcium in passage from the diet of cattle to milk is offset by the greater direct contamination of the herbage cattle graze. Avoidance of foods that accumulate ^{137}Cs would seem equally impracticable. Therefore it seems that the intake of radioactivity in diet could be reduced by a considerable factor only if stocks of stored foods were available for several years or if crops were grown in greenhouses to protect them from direct contamination by fallout.

The following conclusions are inescapable: A large part of the dose from long-lived nuclides could not be avoided, and procedures available for mitigating some fraction of the dose would involve considerable effort and would possibly restrict food supplies.

Would it be reasonable to place this burden on the surviving population? In other words, would it be likely that casualties from radiation could be reduced enough to make the expenditure of effort worthwhile? This final question can be considered in two ways; the expected dose from long-lived nuclides can be compared with that to which the community is inescapably committed from natural background, or casualties to which long-lived nuclides would give rise in the absence of remedial action can be estimated.

Since the average natural background is about 0.1 rad/year, the dose commitment from long-lived fission products to the survivors of a war involving 5000 Mt of fission should be less than one-third of that received from background in the average life-span of man and considerably lower than that received in areas of high natural background. One could scarcely blame survivors of a nuclear holocaust if they felt that this risk was not worthy of consideration. However, to satisfy ourselves further, we will consider the number of casualties that might occur. An International Commission on Radiological Protection (ICRP) report¹⁴ suggested that 1 rad delivered to one million persons might cause about 20 cases of leukemia and about 20 cases of other fatal cancers, the majority of which would not be in bone. On this basis we could expect about 40 leukemias per million of the population from the estimated total of 2 rads to bone marrow and about 20 cancers in other tissues receiving about 1 rad from ^{137}Cs only—a total of about 60 cases per million people. However, since a more recent assessment¹⁵ suggests that these figures may be underestimated because of insufficient information on the length of the latent period, we will assume for prudence that up to 200 people per million might eventually die from cancer induced by the long-term components of fallout. The figure, of course, becomes more alarming when applied to a large population. Among 200 million persons, approximately the population of the United States, there might

be 40,000 casualties during the recovery period. Although this is a large number, it is smaller than the number of annual fatalities on the roads of this country and of many other countries that are called advanced. In short, the total deaths caused by long-lived nuclides seem broadly comparable to the annual traffic death rate. Without expressing an opinion on the correctness of the community's attitude toward road safety, we would point out that road casualties could be greatly restricted by action that would impose a vastly smaller load on the resources of the community than would any measures to reduce casualties from long-lived nuclides after a nuclear war. Thus, by the standards the community now accepts, remedial action against the risks from long-lived nuclides would not seem justified; the number of casualties would be so small relative to the total loss and the difficulty of avoiding them would be so great that remedial action could not reasonably be contemplated.

We may conclude therefore that, in so far as our responsibilities lie in the field of civil defense, efforts to mitigate doses from radiation should be devoted solely to the early period when short-lived nuclides predominate. That is a sufficient problem.

APPENDIX A: DEPOSITION OF ^{90}Sr IN NEAR-IN FALLOUT WHEN EXTERNAL GAMMA DOSE IS 100 R/HR AT 1 HR

Dunning and Hilcken¹⁶ estimated that a deposition of 800 MCi of mixed fission products per square mile 1 hr after fission would give an external gamma dose rate of 4000 R/hr at 3 ft above a theoretically flat plane. Assuming that the roughness of the ground would attenuate the external radiation dose by a factor of 2, that ^{90}Sr contributes 0.0013% of the total fallout activity at 24 hr¹⁷ (adjusted for a half-life of 28 years), that mixed fission products are deposited in fission yield, and that they decay by a factor of 36 in 24 hr, the expected deposit of ^{90}Sr would be 5000 mCi/km² when the external gamma dose rate is 100 R/hr at 1 hr. An alternative calculation based on Glasstone¹⁸ gives about one-third of this value, but we used the higher figure here, having in mind possible variability in different circumstances. We must, however, take account of the fractionation of fission products; the volatility of ^{90}Kr , the gaseous precursor of ^{90}Sr , is likely to deplete ^{90}Sr in the near-in deposit by a factor that may be conservatively estimated¹⁹⁻²² at 5. Thus a deposit of 1000 mCi of ^{90}Sr per square kilometer is expected when the external gamma dose rate is 100 R/hr at 1 hr. There is much evidence²²⁻²⁴ that the deposit in such areas will be of low solubility (probably not more than 10%), but, to avoid understatement of the quantities of ^{90}Sr which may enter food chains in subsequent years, we assumed 50% becomes soluble in the soil.

APPENDIX B: RELATION BETWEEN THE EXTENT OF NUCLEAR FISSION AND WORLDWIDE FALLOUT IN THE SAME HEMISPHERE

The pattern of fallout from the series of nuclear tests in 1962 provides a basis for estimating the deposition of ^{90}Sr in worldwide fallout after a nuclear war. Tests in the USSR are estimated to have yielded 60 Mt of fission²⁵ with a mean time of origin²⁶ at mid-September 1962. The average deposition of ^{90}Sr in the United Kingdom in 1963 was 19 mCi/km², and measurements of fission-product ratios²⁷ indicated that, in the spring and summer of that year, 70% of the ^{90}Sr was from tests held in 1962. This includes a small contribution from the United States 1962 equatorial tests. If we assume that 60 Mt of fission caused $0.7 \times 19 = 13.3$ mCi $^{90}\text{Sr}/\text{km}^2$ to be deposited in the year after the detonations occurred, then, assuming similar latitude and height of injection, 5000 Mt of fission would give rise to 1100 mCi of ^{90}Sr per square kilometer in the first year after detonation.

The deposition in subsequent years would decrease at a rate depending on the residence time of the debris in the stratosphere and on interhemispheric transfer. From 1963 to 1966 the total content of the atmosphere decreased at a fairly steady rate, corresponding to a half-time for deposition estimated at 10 to 13 months; estimates of the longer half-time for interhemispheric transfer lie between 1.5 and 3.5 years.²⁸⁻³⁰ For present purposes a round figure of 1 year has been taken as the effective half-time for the transfer of ^{90}Sr from the stratosphere onto the earth's surface.

REFERENCES

1. R. S. Russell, Dietary Contamination—Its Significance in an Emergency, in *Radiological Protection of the Public in a Nuclear Mass Disaster*, pp. 279–306, Fachverband für Strahlenschutz, Interlaken, 1968.
2. United Nations, Report of the Scientific Committee on the Effects of Atomic Radiation, General Assembly Official Records, Thirteenth Session, Supplement No. 17 (A/3838), New York, 1958.
3. B. O. Bartlett and R. S. Russell, Prediction of Future Levels of Long-Lived Fission Products in Milk, *Nature*, 209: 1062–1065 (1966).
4. United Nations, Report of the Scientific Committee on the Effects of Atomic Radiation, General Assembly Official Records, Seventeenth Session, Supplement No. 16 (A/5216), New York, 1962.
5. United Nations, Report of the Scientific Committee on the Effects of Atomic Radiation, General Assembly Official Records, Twenty-fourth Session, Supplement No. 13 (A/7613), New York, 1969.
6. B. O. Bartlett, An Improved Relationship Between the Deposition of Strontium-90 and the Contamination of Milk in the United Kingdom, in Agricultural Research Council, Letcombe Laboratory, Annual Report 1970, p. 27, 1971.

7. E. Van der Stricht, P. Gaglione, and M. de Bortoli, Predictions of Strontium-90 Levels in Milk on the Basis of Deposition Values, Abstract of paper given at 2nd International Congress of the International Radiation Protection Association, May 3-8, 1970, Brighton, England, *Health Phys.*, **19**: 119 (1970). See also C. Stievenart and E. Van der Stricht. L'Évolution de la radioactivité ambiante au cours des années 1962 à 1966 et ses conséquences pour la contamination radioactive de la chaîne alimentaire, Euratom Report EUR4212f, 1968.
8. G. M. Milbourn, The Uptake of Radioactive Strontium by Crops Under Field Conditions in the United Kingdom, *J. Agr. Sci.*, **55**: 273-282 (1960).
9. P. Newbould, The Absorption of Nutrients by Plants from Different Zones of the Soil, in *Ecological Aspects of Mineral Nutrition of Plants*, I. H. Rorison (Ed.), pp. 177-190, Blackwell Scientific Publications Ltd., Oxford, 1969.
10. H. M. Squire, Long-Term Studies of Strontium-90 in Soils and Pastures, *Radiat. Bot.*, **6**: 49-67 (1966).
11. Medical Research Council, The Assessment of the Possible Radiation Risks to the Population from Environmental Contamination, Her Majesty's Stationery Office, London, 1966.
12. R. S. Russell, Radioisotopes and Environmental Circumstances: The Passage of Fission Products Through Food Chains, in *Radioisotopes in the Biosphere*, R. S. Caldecott and L. A. Snyder (Eds.), pp. 269-292, University of Minnesota Press, Minneapolis, 1960.
13. W. Fletcher, J. F. Loutit and D. G. Papworth, Interpretation of Levels of Strontium-90 in Human Bone, *Brit. Med. J.*, **ii**: 1225-1230 (1966).
14. International Commission on Radiological Protection, The Evaluation of Risks from Radiation, ICRP Publication 8, Pergamon Press, Inc., Oxford, 1966.
15. International Commission on Radiological Protection, Radiosensitivity and Spatial Distribution of Dose, ICRP Publication 14, Pergamon Press, Inc., Oxford, 1969.
16. G. M. Dunning and J. A. Hilcken (Eds.), The Shorter-Term Biological Hazards of a Fallout Field, USAEC Report M-6637, Division of Biology and Medicine and Armed Forces Special Weapons Project, December 1956.
17. R. C. Bolles and N. E. Ballou, Calculated Activities and Abundances of ^{235}U Fission Products, USAEC Report USNRDL-456, Naval Radiological Defense Laboratory, Aug. 30, 1956.
18. S. Glasstone, The Effects of Nuclear Weapons, USAEC Report ACCESS-127, Defense Atomic Support Agency, 1962.
19. G. M. Dunning, Biological Effects of a Nuclear Attack, USAEC Report TID-5563, Division of Biology and Medicine, September 1959.
20. K. Edvarson, K. Löw, and J. Sisefsky, Fractionation Phenomena in Nuclear Weapons Debris, *Nature*, **184**: 1771-1774 (1959).
21. E. C. Freiling, Radionuclide Fractionation in Bomb Debris, *Science*, **133**: 1991-1998 (1961).
22. J. F. Loutit and R. S. Russell, The Entry of Fission Products into Food Chains, *Progress in Nuclear Energy*, Series VI, Vol. 3, Pergamon Press Inc., New York, 1961.
23. E. A. Schuert, A Fallout Forecasting Technique with Results Obtained at the Eniwetok Proving Ground, in *The Nature of Radioactive Fallout and Its Effects on Man*, pp. 280-321, U. S. Congress Hearings, 1957.
24. T. Triffet, Basic Properties and Effects of Fallout, in *Biological and Environmental Effects of Nuclear War*, pp. 61-100, U. S. Congress Hearings, 1959.
25. Federal Radiation Council, Estimates and Evaluation of Fallout in the United States from Nuclear Weapons Testing Conducted Through 1962, F.R.C. Report No. 4, Superintendent of Documents, U. S. Government Printing Office, Washington, D. C., May 1963.

26. R. S. Cambray, E. M. R. Fisher, G. S. Spicer, C. G. Wallace, and T. J. Webber, Radioactive Fallout in Air and Rain: Results to the Middle of 1963, British Report AERE-R-4392, Nov. 18, 1963.
27. R. S. Cambray, E. M. R. Fisher, G. S. Spicer, C. G. Wallace, and T. J. Webber, Radioactive Fallout in Air and Rain: Results to the Middle of 1964, British Report AERE-R-4687, November 1964; and R. S. Cambray, personal communication.
28. D. H. Peirson and R. S. Cambray, Interhemispheric Transfer of Debris from Nuclear Explosions Using a Simple Atmospheric Model, *Nature*, **216**: 755-758 (1967).
29. P. Fabian, W. F. Libby and C. E. Palmer, Stratospheric Residence Time and Interhemispheric Mixing of Strontium-90 from Fallout in Rain *J. Geophys. Res.*, **73**: 3611-3616 (1968).
30. P. W. Krey and B. Krajewski, HASL Model of Atmospheric Transport, USAEC Report HASL-215, New York Operations Office (AEC), September 1969.
31. R. S. Cambray, E. M. R. Fisher, W. L. Brooks, and D. H. Peirson, Radioactive Fallout in Air and Rain: Results to the Middle of 1969, British Report AERE-R-6212, November 1969; and R. S. Cambray, personal communication.
32. Agricultural Research Council, Letcombe Laboratory, Annual Report 1969, Report ARCRL-20, 1970.

CONTROL OF FALLOUT CONTAMINATION IN THE POSTATTACK DIET

J. C. THOMPSON, JR., R. A. WENTWORTH, and C. L. COMAR
Department of Physical Biology, New York State Veterinary
College, Cornell University, Ithaca, New York

ABSTRACT

Radioactive fallout from nuclear weapons testing has resulted in widespread research efforts designed to define pathways, establish deposition and uptake models, and develop predictive capabilities for radionuclide levels and their associated hazards. Within this broad research effort are methods that offer promise for reducing dietary radionuclide intake levels. The various alternatives considered for the radionuclides of primary importance (^{131}I , ^{90}Sr , and ^{137}Cs) are discussed. Much of the actual direction and use of such procedures would depend on the severity of the nuclear attack since many other problems (health, nutrition, etc.) could easily require more-immediate control than those of radionuclide intake. Maximum use of available procedures might occur in releases from a single, isolated event where maximum recovery forces were operating. In contrast, mass nuclear attacks would reduce the immediate priority for controlling radionuclide intake levels, and only the most effective methods might be considered feasible. Under a widespread attack there would be a need for additional guidelines that respond to tolerance or survival levels of radioactivity rather than to the minimum-exposure concept, as all current guidelines do.

Any consideration of the postattack dietary situation must be based on some estimate of the nature and scope of the attack. For example, if the attack were a full-scale strike (maximum effect) followed by extensive retaliatory response and similar secondary retaliations, conditions would be extremely critical throughout the country. If, however, the first strike were directed toward neutralizing the offensive and defensive capabilities to make retaliation null or minimal, the scale of catastrophe might be lessened for certain parts of the country. A strike mediated by antimissile defenses or by the limited offensive capabilities of an aggressor country would have even further reduced effects. Such a strike might be called a limited attack resulting in localized or regionalized disruptions and contamination. The next lower level of disruption would include individual or

isolated nuclear events arising from accidents, sabotage, or intentional large-scale releases in the single-event category.

Reactions or recovery operations after any detonation can be classified as short-term and long-term activities. The most severe attacks would require maximum initial effort during the short-term period to reestablish some semblance of normal order, since most of the population would be in the same general state of disorder. Long-term considerations might not enter into planning until the recovery stage was well under way. In contrast, smaller scale disturbances might easily permit a maximum effort for both short- and long-term activities because of lesser disruption of productive facilities and greater recovery capabilities.

The degree and capability of response to fallout in the diet quite clearly depend on the severity of the initial attack. In reality the response would probably be inversely related to the size of the strike. The larger the attack, the lower the priority of fallout considerations would be; simple human survival would be of greatest importance. Primary civilian emphasis would first center on the maintenance of health and nutrition for the surviving population rather than on concern for any carryover of deleterious effects to succeeding generations. External radiation levels would have to be considered in the context of other hazards at the time. However, radiation considerations should not receive a disproportionate part of the recovery effort at the expense of more critical needs. Radiation safeguards already incorporated into our planning are probably more comprehensive than are plans for many other types of environmental insult. It would be poor operational procedure to initiate efforts to reduce dietary contamination from 10 R to 1 R when general external radiation levels were 100 R and a state of pestilence threatened. Thus the impact of radioactivity in diet would receive a much lower rating when people were faced with the threat of pestilence, hunger, or starvation. Such factors as chemical and biological contamination might warrant much greater attention than radiological concerns during the initial recovery period. As the degree of destruction was reduced or as recovery got under way, more effort could be directed toward radiological considerations with programs designed to minimize the short- and long-term hazard. The greatest efforts in this area could be mobilized after a single nonoffensive type of detonation because of the almost complete availability of resources and facilities.

The apparent conflict between the recovery capability and the total need as illustrated here may ultimately provide better guidelines for emergency conditions. Since the possibility of small disruptions appears greater than that of mass catastrophes, many of the extensive capabilities available during small events can be selectively sorted and programmed for use in larger emergencies. Thus the most effective and direct measures can be assigned use priorities and called upon in a logical order as the needs develop.

GUIDELINES

For the major radionuclides the Federal Radiation Council established graded scales of intake^{1,2} based on Radiation Protection Guides developed in 1960. These scales were not designed for accidental releases or environmental releases not under the control of the government. Misunderstandings arose over the application of these guidelines in 1961 and 1962, however, and a general guidance concept was established in 1964 (Ref. 3) and 1965 (Ref. 4) using the Protective Action Guide (PAG). This represented the projected absorbed dose to individuals in the general population sufficient to warrant protective action following a contaminating event. Intake for the projection is that received by individuals from a contaminating event for which no protective action was taken. Operationally, protective action is needed if the average projected intake by a suitable sample of the exposed population equals one-third of the PAG. Protective actions encompass a variety of measures ranging from simple diet alterations to widespread changes in food production techniques and consumption patterns. Typical action measures have been outlined for the major radionuclides (⁸⁹Sr, ⁹⁰Sr, ¹³¹I, and ¹³⁷Cs) in Federal Radiation Council publications.^{3,4} Special consideration is given to the transmission pathways of radioactive materials and the type of contaminating event.

Protective-action guides were designed for use by the general population where a suitable sample of the exposed population is available. The concept is designed to minimize the risk associated with the use of nuclear energy. Situations expected under nuclear attack are not fully covered, because the basis for the guides is minimum exposure rather than tolerance to radiation levels. In a postattack environment there would be a real need for new guidelines or exposure indexes that specifically consider tolerance. These guidelines would be of an emergency nature, designed especially for certain segments of the population and specifying something between radiation death or incapacitation levels and protective-action guides. They might be called survival action guides. Such guides must take into account differences in age, sex, occupation, location, etc. Preparing guides for the postattack environment would require the establishment of such graded scales of action. In effect, a system of radiation-exposure priorities that became operational when an attack occurred would be necessary.

The present practice of determining decontaminating or clean-up measures based on minimum-exposure levels has considerable merit in that a wide range of possibilities is explored. However, with increasing degrees of attack, the capability for action would be restricted, and only the most effective measures would be utilized. A selection process based on survival conditions under extreme stress is needed, rather than one based on concepts developed for peaceful uses of nuclear energy or for a world at peace. The development of such survival action guidelines would provide the proper basis for action measures

after a nuclear attack. Predictive models and techniques now available for translating contamination levels to exposure commitments could be used to determine appropriate measures to stay within any newly developed guidelines for survival.

CURRENT-ACTION STATUS OF DIETARY DECONTAMINATION

Once priorities based on exposure guidelines for attack conditions are established, the most appropriate dietary control measures for each population group can be selected. Historical data from past fallout studies provide the basis for determining the most important radionuclides, pathways, and remedial measures.

During the initial period after a contaminating event, dietary habits would be altered while external radiation dangers persisted. This would require the use of stored or uncontaminated foods until external levels were minimal. As the danger from external radiation subsided the major hazard would become internal in nature, and a time-related ranking of major radionuclides would evolve as follows:

Initial concern: ^{89}Sr and ^{131}I .

Intermediate concern: ^{89}Sr , ^{90}Sr , ^{131}I , and ^{137}Cs .

Long-term concern: ^{90}Sr and ^{137}Cs .

Since data from fallout programs have established the validity of using milk as one of the most effective indicators of contamination, it is useful to direct most of our efforts to this product. The importance of milk in U. S. dietary habits is well recognized, as is the general pattern of milk production, distribution, and storage. Extensive facilities provide a unique capability for a partial or complete return to productivity soon after interruption. Milk therefore becomes the primary indicator and/or control product for general and specific radiocontamination levels.

Milk

The ability to predict the levels of radionuclide contamination expected in milk following an attack is important for assessing the danger to the population consuming this food, for judging the effect of countermeasures, and for making intrafood comparisons. Many methods have been developed for predicting milk contamination levels from fallout concentrations in the soil or on forage crops. However, with the use of such projections, the greater the distance between fallout deposition and milk secretion, the greater are the uncertainties and assumptions encountered.

A prediction method that eliminates many of these uncertainties is an approach developed primarily by Lengemann and colleagues,⁵⁻¹⁰ which is based

on modeling of experimental data from dairy cows. Using this method, we can estimate the total intake commitment of specific radionuclides from milk by measuring concentrations of these radionuclides in the milk on any given and known day after the start of consumption by cattle of contaminated pasture or forage. This approach gives us some valuable assistance in the matter of surveillance, determination of conditions under which action is to be initiated, and time relations. The technique has been developed for predicting the intake commitments for ^{131}I , ^{89}Sr , ^{90}Sr , and ^{137}Cs . We will explain the general principles using ^{131}I as an example. Figure 1 shows an experimentally derived curve and points representing actual field observations which indicate concentrations of ^{131}I in milk as a function of time after contamination. Figure 2 illustrates the calculation of so-called F factors, which represent the ratio of the total area under the curve to the level on any given day. Thus, from a determination of the ^{131}I level in milk in a particular sample and a table of F factors, we can calculate the total ^{131}I intake commitment of humans drinking the milk. The important factor that gives validity to this method is that the shapes of the curves are such that they give constant F values no matter how the absolute height of the secretion curves varies. Calculated relative standard errors of F factors based on F values calculated from secretion curves for individual cows range from a high of 7% for ^{137}Cs and 3.3% for ^{131}I on the first day after pasture contamination to a low of 0.2% for both radionuclides a few days later. Such F factors have been calculated for radioisotopes of iodine, strontium, and cesium and have been refined to account for other variables, such as varying deposition rates of fallout on pasture, single or multiple depositions of fallout, pasture loss rates, and transit times of milk before it is consumed. In a postattack situation the milk radionuclide-secretion functions and accompanying F factors would be of value in (1) predicting the effect of time on concentrations of radionuclides in milk when cows are on pasture, (2) calculating the intake commitment by humans drinking milk, (3) calculating the effectiveness of removing cows to clean feed or invoking other countermeasures, and (4) predicting the effect of returning cows to pasture feeding.

The effectiveness of two obvious and important countermeasures to reduce radionuclide intake via milk, namely, to stop drinking contaminated milk and to move cattle from pasture to uncontaminated feed, can easily be judged from the secretion functions. As shown in Fig. 3, if a man stops consuming contaminated milk on a given day, the reduction of his intake commitment can be calculated by the ratio of the appropriate areas under the curve. The same procedure can be used if animals are removed from contaminated pasture, as shown in Fig. 4. The net results are presented in Fig. 5, which allows us to make some important generalizations about the one most important factor governing the extent of reduced intake which can be attained—time. Note that, at early times (2 days), stopping milk consumption as a countermeasure against ^{131}I is about twice as effective as shifting cows to uncontaminated food; thereafter the difference

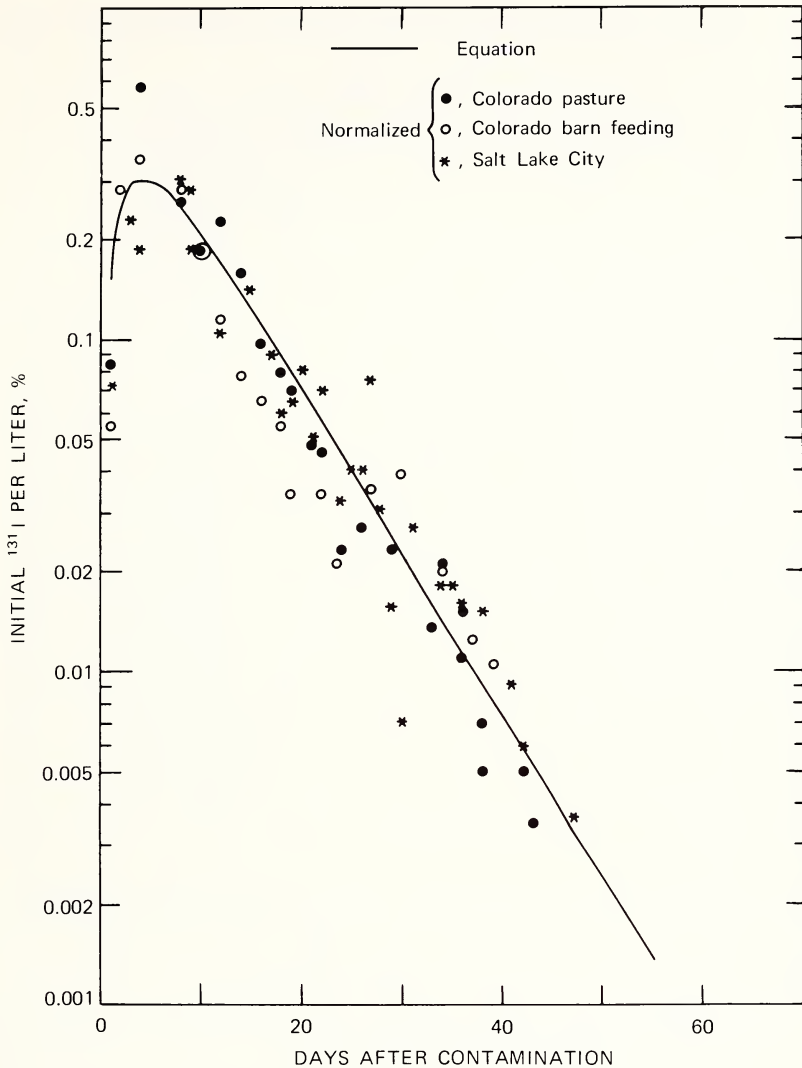

Fig. 1 Experimentally derived curve showing relation between ^{131}I levels in milk (%/liter) and time after contamination.

becomes progressively smaller. Action must be taken within about 4 days if the effectiveness is to be of the order of 90% (Refs. 6, 10, and 11). These procedures will involve various logistic problems of replacement of fresh milk by stored or processed milk and replacement of cattle feed by stored rations.

The same model can be used to predict the levels of radiocontamination when cows are returned to pasture or fed contaminated forage. As depicted in

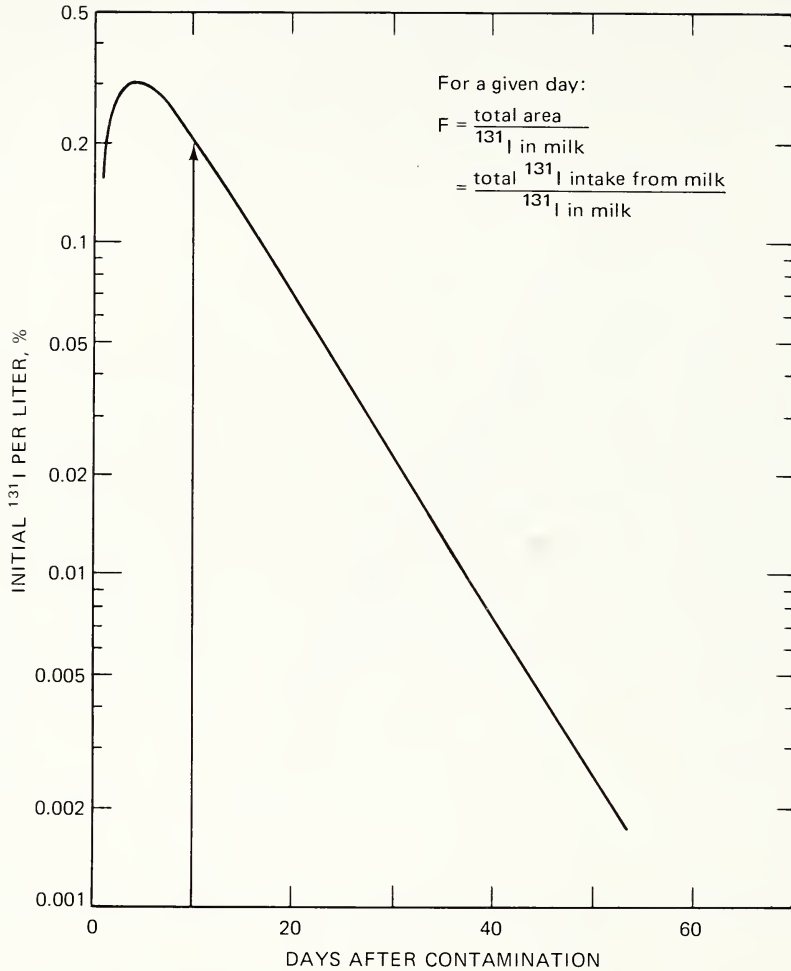

Fig. 2 Illustration of F value calculations used to determine ^{131}I intake commitments.

Fig. 6, the milk-secretion curve is displaced to the right to the selected day when the cows are to be returned to grazing and is adjusted downward by the appropriate pasture loss and decay factors. The total intake commitment by persons drinking the milk after the cows are returned to pasture is thus the original precountermeasure commitment adjusted downward by the pasture loss and decay factors. In this example, removing cows from pasture on day 1 results in an 8% intake commitment, and returning the cows to pasture on day 21 produces an additional 6% intake commitment.

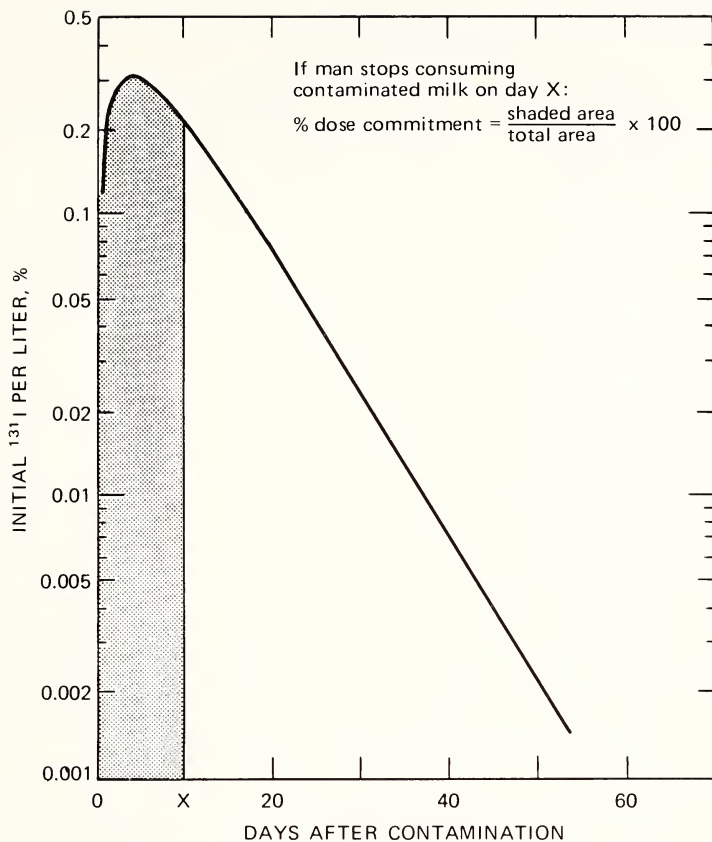

Fig. 3 Calculation of ^{131}I intake commitment when consumption of contaminated milk is stopped.

The model is also applicable to nongrazing management practices and is directly applicable when freshly harvested forages are fed to cattle daily. When contaminated postattack forages are harvested, stored, and fed out during winter months, the same equations will apply, except that the "pasture-loss-rate" factor drops out and a "biological-availability" factor is introduced.

Total Diet

Although direct measurement of radionuclide intake through total dietary assessment provides better estimates than projections from individual food items, the time and effort necessary for collection, analysis, and representative sampling favor the monitoring of the more important individual food indicators. Relations can then be established between such products and total diet to give a

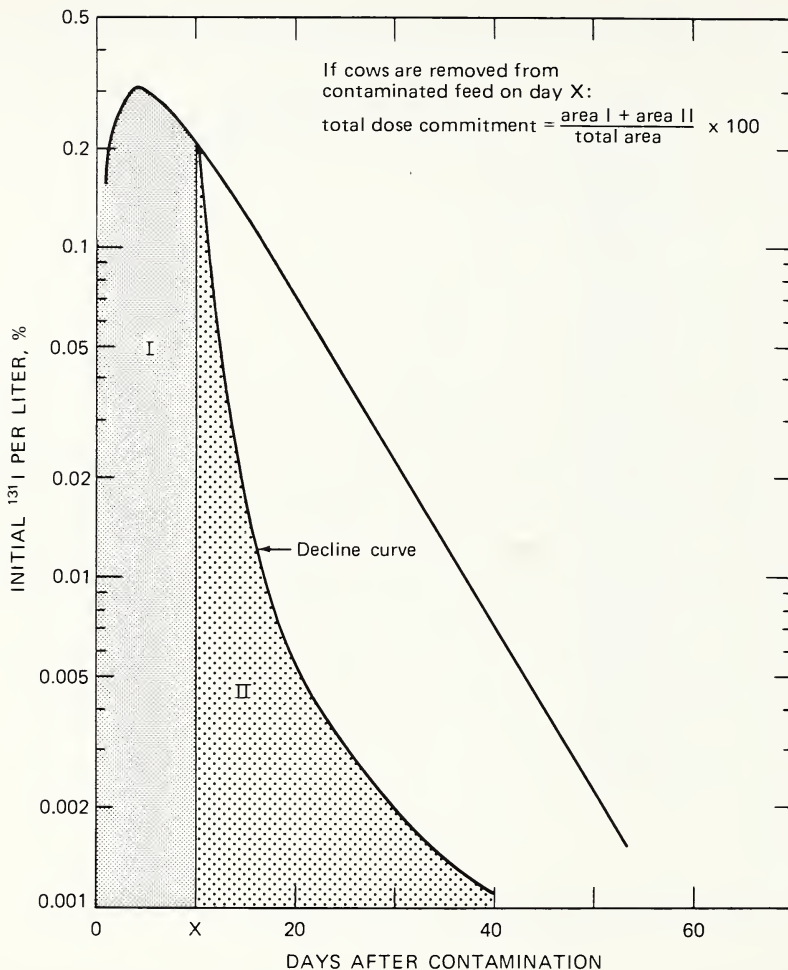

Fig. 4 Calculation of ^{131}I intake commitment when cows are removed from contaminated feed.

fair approximation of radionuclide intake. Some samples of this procedure are shown in Table 1, where the major food components of the tri-city (New York, Chicago, and San Francisco) ^{90}Sr -diet samples are examined in relation to the total-diet analyses.^{6,12} The dietary ^{90}Sr per gram of calcium has been used as the numerator for each food category, and appropriate ratios have been calculated. It is interesting to note the possibility of using samples of dairy products, cereals, or fruits and vegetables to estimate total dietary ^{90}Sr levels in the United States. Major deviations in predictability occur during periods of high fallout (1963), but otherwise the range of values is fairly consistent. Thus total

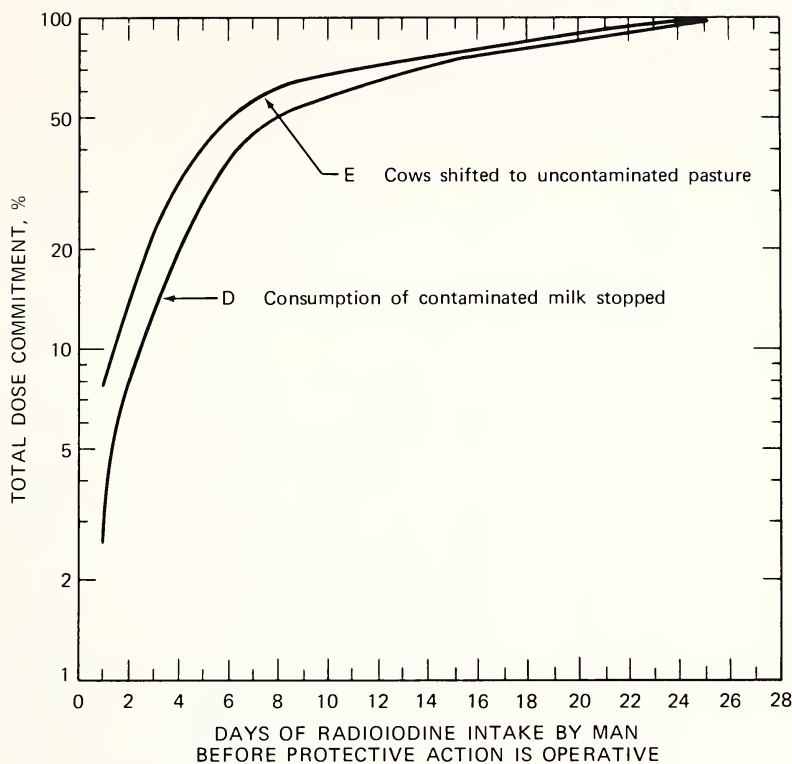

Fig. 5 Comparison of ^{131}I intake commitments when consumption of contaminated milk is stopped and when cows are shifted to uncontaminated pasture.

dietary ^{90}Sr levels could be estimated with a fair degree of accuracy by measuring ^{90}Sr levels in dairy foods and multiplying the result by a factor of 1.3 to 1.5. In a similar fashion, a factor of 0.9 to 1.1 for cereals and 0.4 to 0.6 for fruits and vegetables would also give the general range of ^{90}Sr dietary levels. During periods of high fallout-deposition rates (levels very high), this procedure would result in a lower estimate of dietary radionuclide levels (lag) and should not form the only basis of evaluation. Supplementary samples and analyses would have to be scheduled during periods experiencing major changes in fallout-deposition rates. This procedure is most applicable to dietary conditions expected for the developed nations of the world.

The general relation of this procedure is shown in Figs. 7 to 10, where linear regressions are calculated for the various ratios (diet to milk, diet to fruits, diet to vegetables). Although data from throughout the world have been used in these calculations, the regression lines and confidence intervals fall within a

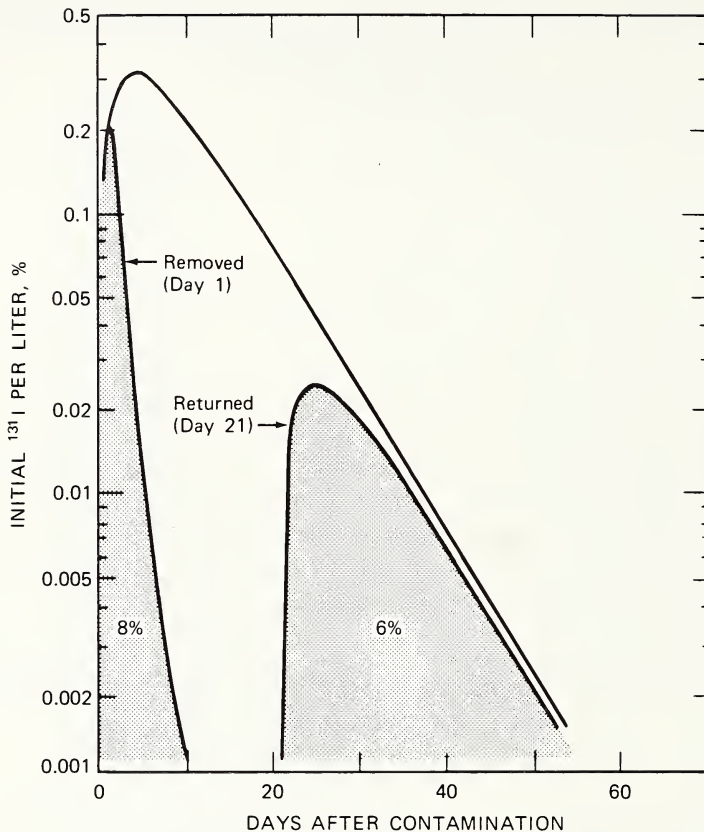

Fig. 6 Effect of removing cows from pasture on ^{131}I levels in milk.

relatively narrow range. They could be used to characterize conditions expected following an accidental release of radioactivity or the resumption of testing and might permit simplification of sampling programs in many areas. However, the use of this technique would not be a substitute for more-detailed analyses as conditions may warrant.

Urinary assays have also proved quite useful in evaluating radionuclide levels for the general population. Various researchers¹³⁻²³ have shown the applicability of urine-to-diet ratios for ^{90}Sr and ^{137}Cs . During normal conditions a urine-to-diet ratio of 0.8 to 1.0 for ^{90}Sr was observed for most subjects (there were some decided variations for younger persons and those on low-milk or low-calcium diets). Similar ratios exist for ^{137}Cs (urine-to-diet ratio, 0.9 to 1.0), but the major use of ^{137}Cs observations is to relate urinary levels directly to body burdens. A general range of 2 to 5 has been obtained for the body-to-diet and body-to-urine $^{137}\text{Cs/g K}$ relation.²⁴⁻²⁶

Table 1
TYPICAL DIET/FOOD ^{90}Sr RATIOS* IN THE UNITED STATES, 1960-1969,
ACCORDING TO THE TRI-CITY DIET STUDIES†

Food group	1960	1961	1962	1963	1964	1965	1966	1967	1968	1969
New York City										
Dairy products	1.4	1.3	1.3	1.1	1.3	1.4	1.5	1.7	1.6	1.4
Cereals	0.9	1.0	1.0	0.9	0.7	0.7	0.8	1.1	1.5	1.4
Fruits and vegetables	0.4	0.5	0.6	0.9	0.5	0.6	0.4	0.3	0.3	0.3
Meat, fish, poultry, and eggs	2.8	0.7	0.8	1.1	2.8	1.8	1.8	2.1	3.1	3.3
Chicago										
Dairy products	1.6	2.0	1.6	1.3	1.6	1.6	1.5	1.9		
Cereals	0.7	0.8	0.7	0.6	0.5	0.6	0.7	0.6		
Fruits and vegetables	0.4	0.3	0.6	0.8	0.5	0.4	0.4	0.3		
Meat, fish, poultry, and eggs	2.2	0.8	0.7	1.4	2.8	1.8	2.2	2.3		
San Francisco										
Dairy products	1.6	2.0	1.5	1.3	1.6	1.3	1.8	2.0	2.2	2.1
Cereals	0.9	0.9	0.7	0.6	0.5	0.8	0.6	0.6	0.8	0.8
Fruits and vegetables	0.4	0.4	0.7	1.0	0.5	0.4	0.4	0.3	0.3	0.3
Meat, fish, poultry, and eggs	1.1	0.5	0.7	0.8	1.8	1.8	1.8	1.8	1.4	0.9

*Ratios are calculated by dividing $^{90}\text{Sr}/\text{g Ca}$ of total diet by $^{90}\text{Sr}/\text{g Ca}$ of appropriate food group.

†Studies were conducted by the Health and Safety Laboratory, U. S. Atomic Energy Commission.

Additional work on the relation between levels of ^{137}Cs in blood and body burdens of ^{137}Cs have also been reported.²⁷ In general, the whole-body levels for male subjects (picocuries per gram of potassium) can be estimated by multiplying the ^{137}Cs content of the blood (picocuries per kilogram) by a factor of 3. This procedure seems appropriate for individuals in the North Temperate Zone.

Since the primary dietary consideration may be the quantity and availability of food, we must know the general level and location of food supplies available for use in emergency conditions. Various surveys have been made^{28,29} which show the normal amount of food supplies on hand by geographic areas in the United States. In Table 2 the normal food supplies in marketing channels are shown for typical conditions expected throughout the country. Although there are some regional variations, in most cases a 100-day food supply (based on a daily intake of 2000 cal per person) is normally available. The supply by area

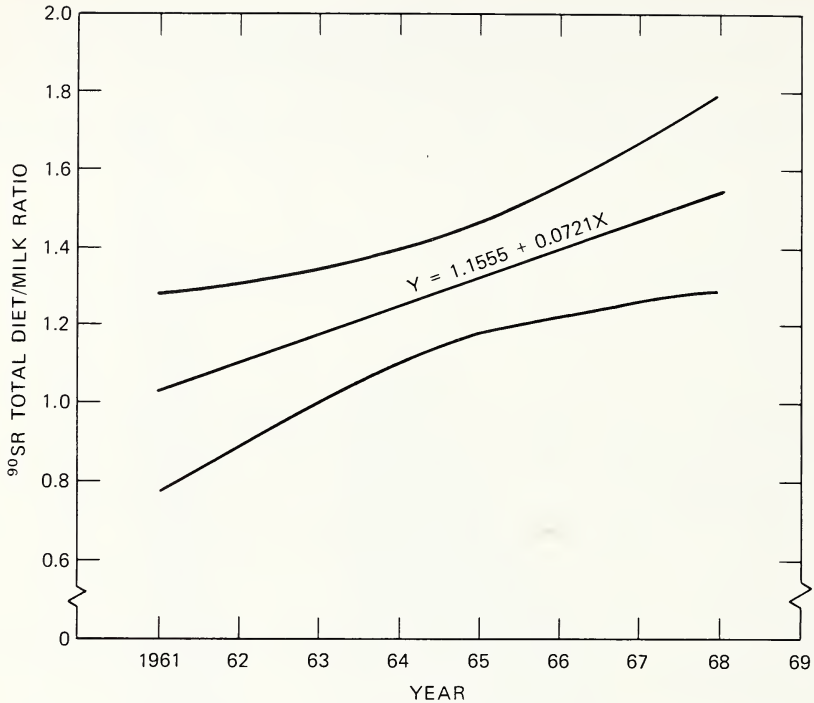

Fig. 7 Linear-regression and confidence-interval estimates for ^{90}Sr diet-to-milk ratios, worldwide data, 1961–1968.

ranges from 81 to 326 days, and some definite seasonal variations are indicated. A much larger supply would be available if all feeds and animals were converted into food equivalents, as shown in Table 3. In this case the range in supplies is extremely wide, extending from more than 9 years in the wheat belt to less than 90 days in the populous Northeast. It is unlikely that we would have the need or the capacity for such an extensive conversion, because it would destroy our animal productivity.

An average supply level of about 90 days for most of the country should give us an opportunity to restore some of our agricultural productivity. Except during the winter season, this time period would be adequate to restore much of the productivity of edible plant crops. In the event of a fall or winter attack, much of the new productivity might have to be temporarily concentrated in the warmer areas of the country. However, the prospect of continuing food production seems to be good. Some special provisions might be necessary to initiate the return to productivity; for example, to make seeds available, a national seed stock or reserve would perhaps be warranted.

Allocation of food stocks or rationing would also be a vital part of total-diet considerations to ensure adequate supplies and to maintain minimal nutritive

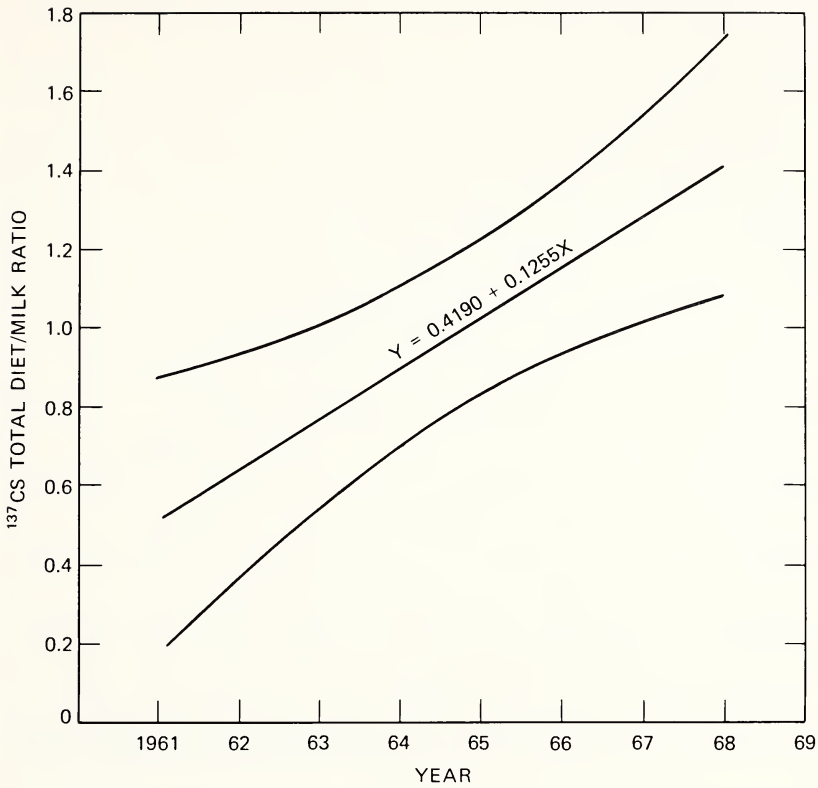

Fig. 8 Linear-regression and confidence-interval estimates for ^{137}Cs diet-to-milk ratios, worldwide data, 1961–1968.

balances. When external levels of radioactive contamination declined, there might be some need to modify diets to minimize radionuclide intake. Much of this effort must take into consideration nutritive needs, occupational status, age, etc. Programs have been described for most fruits and vegetables which take into account the nutritive vs. the radionuclide contributions to maintain nutritional balance, minimize radionuclide intake, and still retain some degree of individual preference or selection.³⁰ Examples of this approach are shown in Tables 4 and 5. In Table 4 the results of such changes are shown for a diet for the New York City area. The major diet categories are indicated, together with their ^{90}Sr and calcium contributions. Fruits and vegetables are listed separately to show the differences in intake arising from processing and substitution practices. Total-diet summaries are presented under each of the conditions considered for the fruit-and-vegetable category (Substitution 1 considers taste and preference criteria, and Substitution 2 considers the maximal ^{90}Sr reduction). Processing fruits and vegetables can reduce total dietary ^{90}Sr intake by 13%, whereas

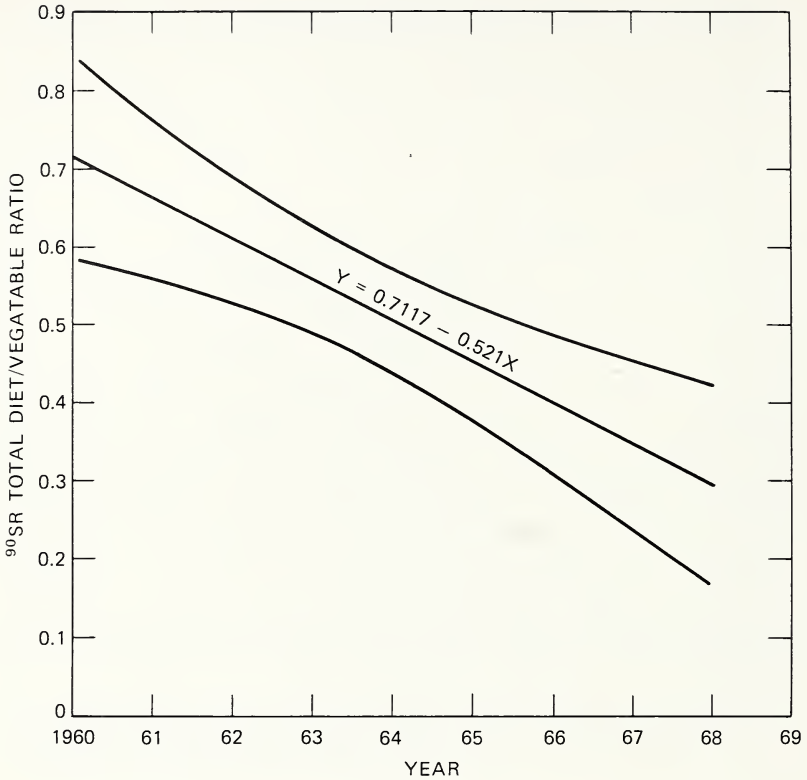

Fig. 9 Linear-regression and confidence-interval estimates for ^{90}Sr diet-to-vegetable ratios, worldwide data, 1960–1968.

processing, coupled with substitution alternatives, reduces the total intake by 21 and 26%. Similar reductions occur in the level of ^{90}Sr per gram of calcium. Calcium intake under all conditions has been maintained at 93 to 97% of initial levels. In addition, vitamin A, ascorbic acid, and iron intake levels were also maintained well above recommended standards.

Substituting in a nondairy diet would produce some additional reductions in the ^{90}Sr intake. However, the deletion of dairy products would result in a major calcium loss, a loss that could not be recovered by increases in the consumption of other foods. An example of this approach is shown in Table 5, where dairy products have been deleted from the diet for the New York City area. Although the net ^{90}Sr intake has been reduced by 46 to 67%, the calcium intake has also been reduced by more than 60%. Such a diet would require considerable calcium supplementation to maintain adequate nutrition since it provides for an intake of only 138 to 156 g of calcium, whereas recommended diet levels are 290 to 510 g, depending on the age of the subject. Supplemental additions of inorganic

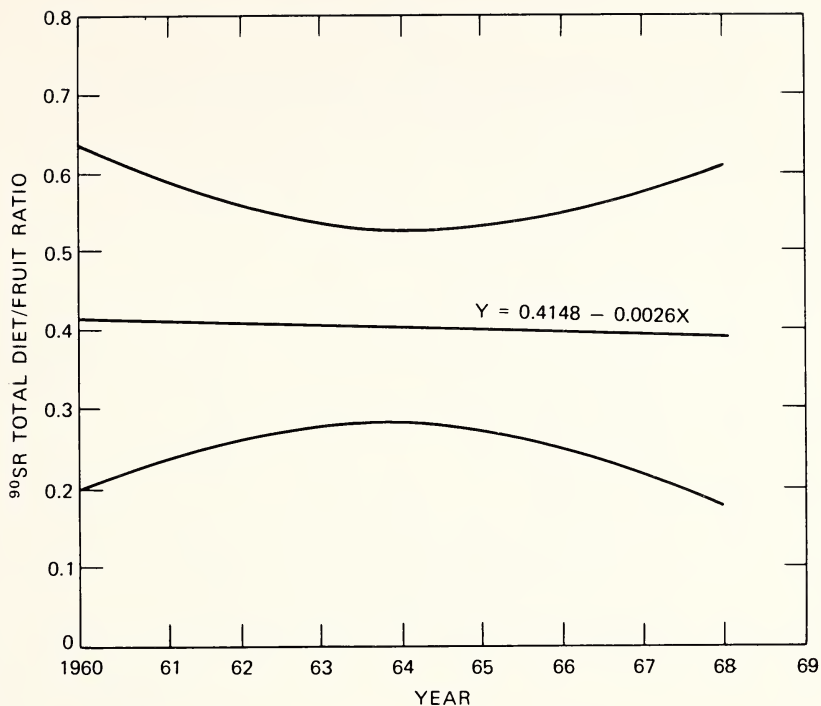

Fig. 10 Linear-regression and confidence-interval estimates for ^{90}Sr diet-to-fruit ratios, worldwide data, 1960–1968.

calcium could be used to further reduce the ^{90}Sr per gram of calcium, but proper medical investigations must be made before such practices become available for general use.

Other dietary alterations, such as using various additives, stopping consumption of certain highly contaminated foods, and using supplementary products, are also effective under certain conditions. They are briefly discussed for the three major radionuclides.

Dietary Alterations and ^{131}I Intake

Previous discussions under the section on milk indicate the effects on total dose commitment of stopping milk consumption (Fig. 5). If consumption stops within the first few days, the dose commitment is less than 10% of the total possible dose. In any event, action must be taken within the first week if a 50% reduction in total dose commitment is to be obtained. Other methods of reducing ^{131}I effects on a large population, such as the administration of high levels of stable iodine or other chemicals to cattle or to man, either are not effective or would be difficult to apply on a large scale.³¹ However, the use of

Table 2
 NORMAL FOOD SUPPLIES IN THE UNITED STATES, 1963*

Area	Normal supply, days	
	January 1	July 1
Region 1, Northeast	94	81
Region 2, Mid-Atlantic	82	77
Region 3, Southeast	122	101
Region 4, North Central	125	109
Region 5, South Central	117	106
Region 6, Great Plains	197	142
Region 7, West	150	94
Region 8, Northwest	326	136
U. S. average	125	98

*Estimates are based on food considered ready for use (excluding unprocessed grains, live animals, etc.) and converted to caloric equivalents. Daily consumption level is taken to be 2000 calories per person.

Table 3
 TOTAL SUPPLIES OF ALL FOOD STOCKS IN THE UNITED STATES, JULY 1967*

Area	Supply, days	
	3000 cal	2000 cal
Region 1, Northeast	84	112
Region 2, Mid-Atlantic	197	262
Region 3, Southeast	223	297
Region 4, North Central	2029	2699
Region 5, South Central	474	630
Region 6, Great Plains	3402	4525
Region 7, West	210	279
Region 8, Northwest	1022	1359

*Estimates assume conversion of all animals and grains into edible supplies.

Table 4
RELATION OF SUBSTITUTION PRACTICES AMONG FRUITS AND
VEGETABLES TO TOTAL ANNUAL DIETARY ^{90}Sr INTAKE
FOR NEW YORK CITY AREA (3-YEAR AVERAGE, 1961-1963)

	^{90}Sr intake,* pCi/year	Calcium intake, g/year	^{90}Sr , pCi/g Ca
Food Groups			
Dairy products	3762	238.22	15.9
Grain products	1039	58.72	17.8
Meat, fish, and eggs	162	44.78	3.4
Diet subtotal	4963	341.72	14.5
Fruits and vegetables			
Unprocessed	2582	64.07	40.3
Processed	1583	53.18	29.8
Substitution 1†	989	38.82	25.5
Substitution 2†	636	34.63	18.4
Total Diet			
Classification of fruits and vegetables in diet:			
Unprocessed	7545	405.79	19.1
Processed	6546	394.90	16.6
Substitution 1†	5952	380.54	15.1
Substitution 2†	5599	376.35	14.2

* ^{90}Sr determinations were obtained from Tri-City Diet Study, Health and Safety Laboratory Fallout Program Reports.^{1,2}

†Substitution 1 classifies fruits and vegetables into use, taste, and preference subcategories so that dietary changes are in accord with normal practices. Substitution 2 uses maximal possible reductions without concern for taste or preference criteria.

stable iodine to block thyroid accumulation of ^{131}I from inhalation could be very useful under certain conditions, particularly in the event of reactor accidents.^{3,2,3,3} The blocking dose to man is about 30 mg, but the time for complete blocking is decreased to about $\frac{1}{2}$ hr if a 100-mg dose is used; after such a single dose, the uptake returns to normal in about 8 days. Repeated doses can be used to maintain blocking. Schedules of from 35 mg every 12 hr to 250 mg every 4 hr have been proposed.

Table 5
 EXAMPLE OF SUBSTITUTION PRACTICES AMONG FRUITS
 AND VEGETABLES FOR A NONDAIRY DIET FOR NEW YORK
 CITY AREA (3-YEAR AVERAGE, 1961-1963)

	⁹⁰ Sr intake,* pCi/year	Calcium intake, g/year	⁹⁰ Sr, pCi/g Ca
Food Groups			
Grain products	1039	58.72	17.8
Meat, fish, and eggs	162	44.78	3.4
Diet subtotal	1201	103.50	11.6
Fruits and vegetables			
Unprocessed	2582	64.07	40.3
Processed	1583	53.18	29.8
Substitution 1†	989	38.82	25.5
Substitution 2†	636	34.63	18.4
Total Diet			
Classification of fruits and vegetables in diet:			
Unprocessed	3783	167.57	22.6
Processed	2784	156.68	17.8
Substitution 1†	2190	142.32	15.4
Substitution 2†	1837	138.13	13.3

*⁹⁰Sr determinations were obtained from Tri-City Diet Study, Health and Safety Laboratory Fallout Program Reports.^{1,2}

†Substitution 1 classifies fruits and vegetables into use, taste, and preference subcategories so that dietary changes are in accord with normal practices. Substitution 2 uses maximal possible reductions without concern for taste or preference criteria.

Dietary Alterations and ⁹⁰Sr Intake

In regard to ⁹⁰Sr, we are primarily interested in remedial measures of chronic nature since we assume that the input will remain contaminated over long periods of time. We have pointed out that, for manipulation of diet to produce a minimum body burden of radioactive strontium, we should aim for a minimum value of $O.R.\text{-body}/\text{diet}$ divided by the percent calcium in the diet^{3,4} where

$$\text{O.R.}_{\text{body/diet}} = \frac{\text{Sr/Ca of body}}{\text{Sr/Ca of diet}} \quad (1)$$

In experimental studies with rats, we have been able to reduce the strontium burden by a factor of almost 10 by adjustment of diets containing high levels of calcium, phosphorus, and magnesium.^{3,5} Similar results have not been tested rigorously with human beings. It is possible to reduce the strontium-to-calcium ratio of milk by a factor of 2 to 4 by increased calcium feeding of dairy cows.^{3,6} Such dietary interventions are not feasible, however, for two main reasons: (1) unknown possible side effects over long times and (2) difficulty of implementation. (As a side note, we should emphasize that supplemental calcium should originate from an uncontaminated source, i.e., inorganic as opposed to animal sources. A study of commercial calcium tablets showed that many of them were derived from bone meal carrying a higher ⁹⁰Sr-to-calcium ratio than the contemporary diet.^{3,7})

The extent of reductions possible by modifications of dietary habits is of interest. Two time periods are compared: (1) early after the contamination event when surface deposition is prominent and (2) later when the soil-plant-animal-products pathway is more important. From our knowledge of discrimination processes, we have been able to predict the relative degrees of contamination among various types of foods. We now have some data to support these ideas, and the following discussion is based primarily on survey data, with calculated modifications based on experimentation.

Table 6 shows a typical pattern of calcium and ⁹⁰Sr contribution to the diet during a period shortly after a contaminating event.^{3,8} Note that dairy products and fruits and vegetables are the major contributors in terms of absolute amounts. Table 7 shows the effect of removing 90% of the ⁹⁰Sr from milk; note that there is less than a 50% reduction in the ⁹⁰Sr-to-calcium ratio of the total diet. For infants or others on a normal diet consisting almost entirely of milk, however, the net effect would be greater. The same general effect could be

Table 6
TYPICAL CALCIUM AND ⁹⁰Sr CONTRIBUTION TO
TOTAL DIET IN NEW YORK CITY, 1961-1963

Food group	Calcium, g/year	⁹⁰ Sr, pCi/year	⁹⁰ Sr/Ca
Dairy products	238	3784	
Grain products	59	1050	
Meat, fish, and eggs	45	153	
Fruits and vegetables	64	2560	
Total	406	7547	18.6

Table 7
EFFECT OF MILK DECONTAMINATION ON CALCIUM AND
 ^{90}Sr DIETARY INTAKE IN NEW YORK CITY, 1961-1963

Food group	Calcium, g/year	^{90}Sr , pCi/year	$^{90}\text{Sr}/\text{Ca}$
Dairy products	238	378	
Grain products	59	1050	
Meat, fish, and eggs	45	153	
Fruits and vegetables	64	2560	
Total	406	4141	10.2

Table 8
EFFECT OF ELIMINATING MILK FROM DIET IN
NEW YORK CITY, 1961-1963

Food group	Calcium, g/year	^{90}Sr , pCi/year	$^{90}\text{Sr}/\text{Ca}$
Grain products	59	1050	
Meat, fish, and eggs	45	153	
Fruits and vegetables	64	2560	
Total	168	3763	22.4

produced by eliminating milk from the diet and substituting inorganic, uncontaminated calcium. Table 8 shows what happens if milk is eliminated from the diet; two detrimental effects occur—a lowered calcium intake and a high ^{90}Sr -to-calcium ratio. If fruits and vegetables are rigorously processed and selected for a low ^{90}Sr -to-calcium ratio, only a small benefit (about 20%) can be attained (Table 9).³⁰ Table 10 summarizes the possible effects of various treatments on the ^{90}Sr -to-calcium ratio of the total diet. Even with the most diligent efforts, only a factor of 3 appears to be attainable. The situation for 1967, representative of a low fallout rate, is also shown in terms of possible reductions.³⁹ The main points are that milk decontamination and manipulation of fruits and vegetables would be comparatively less effective during low fallout than under conditions of high fallout rate.

Within recent years two substances, aluminum phosphate gel and alginates, have been shown to reduce the absorption of strontium from the gut much more than that of calcium. The effect of phosphate gels was first noted by Spencer and colleagues.⁴⁰ Using Phosphajel produced by Wyeth Laboratories, Spencer reported average reductions in strontium uptake in man of about 87% as compared to reductions in calcium uptake of about 37%. Studies with dairy

Table 9

PROCESSING AND SELECTING VEGETABLES FOR LOW ^{90}Sr CONTENT—
EFFECT OF DIETARY INTAKE IN NEW YORK CITY, 1961–1963

Food group	Calcium, g/year	^{90}Sr , pCi/year	$^{90}\text{Sr}/\text{Ca}$
Dairy products	238	3784	
Grain products	59	1050	
Meat, fish, and eggs	45	153	
Fruits and vegetables	39	966	
Total	381	5953	15.6

Table 10

COMPARISON OF VARIOUS TECHNIQUES FOR
REDUCING ^{90}Sr IN TOTAL DIET IN
NEW YORK CITY, 1961–1963 AND 1967

Technique	1961–1963	1967
1. Normal	18.6	15.6
2. Milk 90% decontaminated	10.2	10.4
3. Milk eliminated	22.4	24.1
4. Fruits and vegetables selected	15.6	15.6
5. Combination of techniques 2 and 4	6.0	10.4

cows have shown little effectiveness in reduction in strontium levels in milk because the amounts of phosphate gel that must be fed are impractical.¹¹

There has been considerable interest in the use of alginates. The selective inhibition of strontium absorption following the administration of sodium alginate to rats was first reported by Skoryna, Paul, and Waldron—Edward⁴¹ of Canada; they observed a 50 to 80% reduction of radiostrontium absorption with no significant reduction in calcium absorption. Similar inhibition of radiostrontium absorption by sodium alginate has since been observed in rats and humans by others.⁴²⁻⁴⁴

Commercially available alginates are salts of naturally occurring compound polymers of mannuronic and guluronic acids (alginic acid) which are extracted from brown seaweed (*Phaeophyceae*). Sodium alginate, which is water soluble, is already widely used in the food industries in such products as ice creams, jellies, jams, puddings, etc., as an emulsifying and stabilizing agent.

Alginates with a high guluronic acid content, such as those derived from certain *Laminaria* species, appear to be most effective. When such products are fed to rats at the rate of 10% of their diet, typical reductions in strontium

absorption range from about 75 to 80%, whereas changes in radiocalcium absorption have varied between -29 and +33% (Refs. 42 to 44). Hesp and Ramsbottom in 1965 and Sutton in 1967 reported a reduction in radiostrontium uptake of 64 to 89% when 10 g of sodium alginate derived from *Laminaria* species was fed to adult humans who had fasted overnight.^{45,46} When sodium alginate derived from *Macrocystis pyrifera*, which has a lower guluronic acid content, was administered as a jelly to human adults, strontium retention was reduced by about 56%, whereas radiocalcium retention was reduced by only 18% (Ref. 42).

Humphreys⁴⁷ and Tanaka et al.⁴⁸ described alginate derivatives, some of which appear to be more effective than sodium alginate. A derivative containing 95% L-guluronic acid fed to rats at a rate of 10% of their ration reduced radiostrontium absorption by 84% with no inhibition of calcium absorption, and, when it was consumed by humans, a reduction in the absorption of ^{87m}Sr by 83 to 85% was indicated.^{43,46} Tanaka et al.⁴⁸ after studying several degradation products of alginates, concluded that their strontium binding capacities in vivo are only partly dependent on the presence of a high guluronic acid content.

In a very recent study⁴⁹ of the absorption of ^{47}Ca and ^{85}Sr in four human volunteers with and without sodium alginate, the alginate decreased the retention of ^{85}Sr by 70% and of ^{47}Ca by 7%. The stable elements Na, K, Mg, and P were also studied, and no change was observed in their excretion pattern or plasma level. There has been some indication that alginate interferes with iron metabolism because of its strong binding potential for ferric ion, but this issue is still equivocal.

Our own studies show that sodium alginates have a selective inhibition of strontium absorption in the bovine.¹¹ As in rats and humans, the source of the alginate is important in determining its effectiveness. Using sodium alginate derived from *Laminaria* species, we observed a reduction of about 70 to 80% in milk radiostrontium levels when 5 to 7% of the ration was sodium alginate. A serious problem of palatability of sodium alginate exists with cows. Most cows reject this material when it is included in their rations at levels above 5 to 7%, and some cows will not eat their feed when 1% sodium alginate is included.

We are presently attempting to see what the maximum reduction might be by using a combination of various substances that have been effective individually (Ca, PO_4 , Mg, Phosphajels, alginates). The possible effects on other essential trace minerals is a problem that would have to be explored before any long-term large-scale application could be implemented.

Dietary Alterations and ^{137}Cs Intake

The general methods that tend to reduce ^{131}I and radiostrontium also tend to reduce ^{137}Cs exposures via milk. In contrast to the other radionuclides, however, at early times ^{137}Cs could be an appreciable contaminant of meat.

The feeding of Prussian blue (ferric ferrocyanide) has been of recent interest as a countermeasure against ^{137}Cs . Nigrović^{50,51} observed that oral administration of Prussian blue reduced absorption of ^{137}Cs by as much as 99% in rats. In addition, excretion of parenterally administered ^{137}Cs was accelerated when Prussian blue was fed.

Madshus et al.⁵² reported that feeding young dogs 1.5 to 3 g of Prussian blue daily for 10 days and following by 11 days of whole-body counting reduced the ^{137}Cs biological half-time to 59% of that measured in control dogs. Two of these investigators then ingested 1 μCi of ^{137}Cs and 10 months later started to consume 3 g of Prussian blue per day.⁵³ The biological half-time dropped from 110 to 115 days to about 40 days.

Our own studies have confirmed Nigrović's observations in respect to the effects of Prussian blue fed to rats.¹¹ Furthermore, this material was shown to be effective in the ruminant. Radiocesium levels in the milk of cows have been reduced to about 1% of control levels by feeding Prussian blue simultaneously with the radiocesium. When Prussian blue was administered some time after the ingestion of ^{137}Cs or ^{134}Cs , the decline in radiocesium levels in milk with time was accelerated by as much as a factor of about 5. This effect has been observed at times of even 100 days after the ingestion of cesium. Current studies at our laboratory indicate that Prussian blue is also effective against absorption of radiocesium in such other meat-producing animals as hogs and sheep.

Slight constipation is the only side effect yet observed following ingestion by humans of Prussian blue. The binding mechanism of Prussian blue for cesium in the gastrointestinal tract appears to be so selective that potassium metabolism is not greatly affected.⁵²

DECONTAMINATION

Insofar as decontamination is concerned, most work has been done with milk through cooperative studies by the U. S. Department of Agriculture (USDA), U. S. Atomic Energy Commission (USAEC), and U. S. Public Health Service. Pilot and full-scale facilities that demonstrate the feasibility of removing more than 90% of the major radionuclides by various ion-exchange processes^{54,56} have been developed. Costs have been estimated in the range of 1 to 2¢ per quart, and there is little deterioration of quality. Although this procedure removes radionuclides in milk, the feasibility of employing such a system remains questionable. The advance preparation and planning, coupled with equipment and capital needs, make it an extremely costly procedure. Implementation of widespread milk decontamination facilities would have to be balanced against many other needs during emergency conditions.

Similar problems must be faced in removing contaminants from the land. Procedures have been developed^{57,58} for removing the top layers of contami-

nated soil which reduce contamination levels by more than 90%. However, the resultant disposal problem and the loss in soil productivity present strong physical and economic limitations. Other practices, such as deep plowing, leaching, addition of lime, etc., offer possibilities under certain conditions. Perhaps alterations in farming systems or changes in primary production centers could provide adequate reductions in plant radionuclide levels under most postattack conditions.

Massive fallout contamination might require the implementation of these more drastic measures but only for restricted geographic areas. Their use on a nationwide basis seems hardly likely because, if conditions warrant such uses, the capabilities or capacities to initiate them will already have been lost.

The simplest and most logical decontamination techniques are already available and are in use in the case of most plant foods. Normal food preparation and processing practices in the home and factory remove a significant fraction of the surface-deposited radionuclides. Table 11, which gives a general summary of the normal removal rates, shows that 30 to 60% removal is readily attainable for ^{131}I , ^{90}Sr , and ^{137}Cs . Greater reductions, up to 80 and 90%, are also possible by using more-extensive preparation techniques (several washings, scraping, peeling, cooking, and discarding cooking water).

Table 11
DECONTAMINATING FRUITS AND VEGETABLES*

	^{131}I , % reduction	^{90}Sr , % reduction	^{137}Cs , % reduction
Fruits	25 to 50	20 to 50	20 to 60
Vegetables			
Leafy	30 to 50	25 to 50	30 to 60
Podded	30 to 80	40 to 80	25 to 50
Root		20 to 40	20 to 80
Other	25 to 60	25 to 75	10 to 50

*General ranges of values were obtained from controlled experiments and from data reported in the literature.

Existing treatment facilities for most of the operating water-treatment plants can also remove many of the radionuclides that would be deposited after an attack. Conventional processes such as coagulation and settling remove about 75% of the fallout debris.^{59,60} Many of the slightly soluble fallout particles can be precipitated as metal hydroxides by adding coagulating chemicals. Removal of the soluble particles requires ion-exchange or distillation methods. Individual home water softeners also are very effective, removing more than 90% of the radioactive materials.^{59,60} In shallow ponds or lakes, however, initial and

continuing contamination might be a serious problem during the immediate postattack period.

SUMMARY

Postattack dietary measures would depend on the nature and scope of the initial nuclear attack. Changes in dietary makeup designed to reduce radionuclide intake might be of limited value if mass devastation occurred, because other more pressing needs (survival, health, nutrition) would have much higher priority for a considerable time during the recovery cycle. Once immediate needs were met and a fair degree of recovery were under way, there would be greater need and desire to initiate dietary radionuclide-reduction techniques, particularly for selected population groups important to succeeding generations. The lighter the degree of devastation, the earlier this phase would probably occur, being of primary importance in a single event or when the contamination was limited to a small area.

Although a wide variety of techniques for reducing dietary radionuclide intake is available, there is no single procedure that fits all the requirements considered essential to public health (i.e., effective, safe, practical, and feasible for implementation). The broadest capability for action rests with procedures developed for fluid milk because of its importance in dietary structure and its use as an indicator product. However, despite the wide array of techniques, no single step or procedure solves the problem. Thus supplementary efforts in reducing soil, water, plant, and animal radionuclide contributions would continue to be necessary for maximum possible reductions. They should form an ordered listing of feasible actions available for use when recovery conditions permit.

In line with the use of dietary remedial measures or countermeasures, the need for a survival action guideline becomes apparent. Current philosophy underlying the minimum-radiation-exposure concept does not meet the needs of an attack environment when exposure levels would be much higher for the survivors. Our present planning must be revised to include some concept of special exposure guidelines expected in a postattack environment.

REFERENCES

1. Federal Radiation Council, Background Material for the Development of Radiation Protection Standards, Report No. 1, Superintendent of Documents, U. S. Government Printing Office, Washington, D. C., May 1960.
2. Federal Radiation Council, Background Material for the Development of Radiation Protection Standards, Report No. 2, Superintendent of Documents, U. S. Government Printing Office, Washington, D. C., September 1961.
3. Federal Radiation Council, Background Material for the Development of Radiation Protection Standards, Report No. 5, Superintendent of Documents, U. S. Government Printing Office, Washington, D. C., July 1964.

4. Federal Radiation Council, Background Material for the Development of Radiation Protection Standards: Protective Action Guides for ^{89}Sr , ^{90}Sr , and ^{137}Cs , Report No. 7, Superintendent of Documents, U. S. Government Printing Office, Washington, D. C., May 1965.
5. F. W. Lengemann, Predicting the Total Projected Intake of Radioiodine from Milk by Man. I. The Situation Where No Counter Measures Are Taken, *Health Phys.*, **12**: 825-830 (1966).
6. F. W. Lengemann, Predicting the Total Projected Intake of Radioiodine from Milk by Man. II. The Situation Where Counter Measures Are Employed, *Health Phys.*, **12**: 831-835 (1966).
7. F. W. Lengemann and R. A. Wentworth, Predicting the Total Intake of Radioiodine of Humans Consuming Goat's Milk, *Health Phys.*, **12**: 1655-1659 (1966).
8. F. W. Lengemann, Predicting the Total Projected Intake of Radioiodine from Milk by Man: Modification of the Original Equation, *Health Phys.*, **13**: 521-522 (1967).
9. F. W. Lengemann, R. A. Wentworth, and F. L. Hiltz, Predicting the Cesium-137 Intake from Milk of a Human Population After a Single Short-Term Deposition of the Radionuclide, *Health Phys.*, **14**: 101-109 (1968).
10. C. L. Comar and F. W. Lengemann, General Principles of the Distribution and Movement of Artificial Fallout Through the Biosphere to Man, in *Radioecological Concentration Processes*, B. Aberg and F. P. Hungate (Eds.), Pergamon Press, Inc., New York, 1967.
11. C. L. Comar, R. A. Wentworth, and F. W. Lengemann, A Study of Metabolism of Selected Radionuclides Fed in Various Physical Forms to Dairy Cows. Final Report, Report AD-672097, Cornell University, March 1967.
12. Health and Safety Laboratory, Fallout Program Quarterly Summary Reports, USAEC Reports HASL-42 to 217, AEC New York Operations Office, 1958-1970.
13. Wanda Czosnowska, The Urine-to-Food $^{90}\text{Sr}/\text{Ca}$ Ratio in Relation to Urinary Calcium in Humans, *Nukleonika*, **9**: 757-758 (1964).
14. Wanda Czosnowska, The Sr-90 Level in Urine of Population in Poland in 1962, *Nukleonika*, **8**(11): 779-781 (1963).
15. Wanda Czosnowska, Sr-90 in the Diet in Poland, *Nukleonika*, **9**(9): 745-755 (1964).
16. Wanda Czosnowska, The $^{90}\text{Sr}/\text{g Ca}$ Level in the Human Urine as a Measure of the $^{90}\text{Sr}/\text{Ca}$ Content of the Diet in Poland, in *Proceedings of the Second Symposium on Health Physics*, Pecs, Hungary, Sept. 26-30, 1966, Vol. II, pp. 91-94, Publishing Group of the Central Research Institute for Physics, Budapest, 1966.
17. Wanda Czosnowska, Sr-90 and Ca Excretion in Urine of Man, *Nukleonika*, **11**(6): 459-470 (1966).
18. Wanda Czosnowska, Z. Pietrzak-Flis, and D. Grabowski, Relationship Between the $^{90}\text{Sr}/\text{Ca}$ Ratio in the Diet and Urine of Population, Polish Report CLOR-66/D (1967).
19. Minoru Fujita, Estimation of Dietary Intake of Strontium-90 from Excreta Analysis, *J. Nucl. Sci. Tech. (Tokyo)*, **1**(7): 255-263 (1964).
20. Minoru Fujita, J. Iwamoto, and M. Kondo, Variation of Strontium-Calcium Observed Ratio (Urine/Diet) in Man, *Health Phys.*, **16**: 441-447 (1969).
21. Minoru Fujita, J. Iwamoto, M. Kondo, A. Yabe, and J. Akaishi, Correlation Between Ingestion, Accumulation, and Excretion of Fallout ^{90}Sr in Man on a Long-Term Scale, *Health Phys.*, **17**: 41-50 (1969).
22. J. C. Thompson, Jr., and C. L. Comar, Estimation of Dietary Strontium-90 by Urinary Assay: Applied and Theoretical Aspects, *Health Phys.*, **13**: 5-13 (1967).
23. J. C. Thompson, Jr., and F. W. Lengemann, Dietary Intake of Radionuclides: Effect of Consumption Patterns and Evaluation by Use of Integrating Samples, in *Radioactive Fallout from Nuclear Weapons Tests*, Proceedings of the Second Conference, German-

- town, Md., Nov. 3–6, 1964, A. W. Klement, Jr. (Ed.), AEC Symposium Series, No. 5 (CONF-765), pp. 877–894, 1965.
24. A. Morgan and Gloria M. Arkell, Determination of Cesium-137/Potassium Ratios in Diet and in the Human Body by Urine Analysis, *Nature*, **191**: 1100 (1961).
 25. Mary P. Taylor, J. Vennart, and D. M. Taylor, Retention and Excretion of Cesium-137 by Man, *Phys. Med. Biol.*, **7**: 157–165 (1962).
 26. Masami Izawa and Hiroyuki Tsubota, Cesium-137 Concentration in Human Urine and Estimation of Cesium-137 Body Burden Due to Worldwide Fallout, *J. Radiat. Res.*, **3**: 120–129 (1962).
 27. N. Yamagata, Blood-Cesium-137 Project—1967, *Health Phys.*, **15**: 276–280 (1968).
 28. U. S. Department of Agriculture—Economic Research Service, Food Supplies Available by Counties in Case of National Emergency, AE Report No. 57, July 1964.
 29. J. C. Bresee, S. A. Griffin, and A. F. Shinn, The Vulnerability of Food to Nuclear Attack, in Radiological Protection of the Public in a Nuclear Mass Disaster, Proceedings of a Symposium, May 26–June 1, 1968, Interlaken, Switzerland, Report CONF-680507, pp. 589–607, International Radiation Protection Association, 1968.
 30. J. C. Thompson, Jr., R. R. Alexander, and C. L. Comar, Dietary ^{90}Sr Reductions Through Food Substitutions in the Fruit and Vegetable Category, *J. Nutr.*, **91**(3): 375–382 (1967).
 31. F. W. Lengemann and J. C. Thompson, Jr., Prophylactic and Therapeutic Measures for Radioiodine Contamination—A Review, *Health Phys.*, **9**: 1391–1397 (1963).
 32. C. A. Adams and J. A. Bonnell, Administration of Stable Iodine as a Means of Reducing Thyroid Irradiation Resulting from Inhalation of Radioactive Iodine, *Health Phys.*, **7**: 127–149 (1962).
 33. D. Ramsden, F. H. Passant, C. O. Peabody, and R. G. Speight, Radioiodine Uptakes in the Thyroid, Studies of the Blocking and Subsequent Recovery of the Gland Following the Administration of Stable Iodine, *Health Phys.*, **13**: 633–646 (1967).
 34. K. Kostial, S. Vojvodic, and C. L. Comar, Effects of Dietary Levels of Phosphorus and Calcium on the Comparative Behavior of Strontium and Calcium, *Nature*, **208**(5015): 1110–1111 (Dec. 11, 1965).
 35. J. G. Ebel and C. L. Comar, Effect of Dietary Magnesium on Strontium–Calcium Discrimination and Incorporation into Bone of Rats, *J. Nutr.*, **96**(3): 403–498 (November 1968).
 36. F. W. Lengemann and C. L. Comar, Metabolism of Some Fission Products by Farm Animals, in Agricultural and Public Health Aspects of Radioactive Contamination in Normal and Emergency Situations, Scheveningen, The Netherlands, Dec. 11–15, 1961, Food and Agriculture Organization, United Nations, Atomic Energy Series, No. 5, pp. 92–115, Rome, 1964.
 37. Consumer Union, Calcium Tablets and Strontium-90, *Consumer Reports*, **26**: 452–453 (1961).
 38. Joseph Rivera and J. H. Harley, HASL Contributions to the Study of Fallout in Food Chains, USAEC Report HASL-147, AEC New York Operations Office, Health and Safety Laboratory, July 1, 1964.
 39. Joseph Rivera, ^{90}Sr in Tri-City Diets: Results for 1966 and 1967 and Comparison with Predictions, in Fallout Program. Quarterly Summary Report, Dec. 1, 1967–Mar. 1, 1968, USAEC Report HASL-193, pp. I.217–I.222, AEC New York Operations Office, Health and Safety Laboratory, Apr. 1, 1968.
 40. Herta Spencer, Isaac Lewin, and Joseph Samachson, Preliminary Report. Inhibition of Radiostrontium Absorption in Man, *Int. J. Appl. Radiat. Isotop.*, **18**: 779–782 (1967).
 41. S. C. Skoryna, T. M. Paul, and Deirdre Waldron-Edward, Studies of Inhibition of Intestinal Absorption of Radioactive Strontium. IV. Estimation of the Suppressant Effect of Sodium Alginate, *Can. Med. Ass. J.*, **93**: 404–407 (Aug. 28, 1965).

42. Joan Harrison, K. G. McNeill, and A. Janiga, The Effect of Sodium Alginate on the Absorption of Strontium and Calcium in Human Subjects, *Can. Med. Ass. J.*, **95**: 532-534 (Sept. 3, 1966).
43. G. Patrick, T. E. F. Carr, and E. R. Humphreys, Inhibition by Alginates of Strontium Absorption Studied in vivo and in vitro, *Int. J. Radiat. Biol.*, **12**: 427 (1967).
44. Krista Kostial, Tea Maljković, M. Kadić, R. Maniasević, and G. E. Harrison, Reduction of the Absorption and Retention of Strontium in Rats, *Nature*, **215**(5097): 182 (July 8, 1967).
45. R. Hesp and B. Ramsbottom, Effect of Sodium Alginate in Inhibiting Uptake of Radiostrontium by the Human Body, *Nature*, **208**(5017): 1341-1342 (Dec. 25, 1965).
46. Alice Sutton, Reduction of Strontium Absorption in Man by the Addition of Alginate to the Diet, *Nature*, **216**(5119): 1005-1007 (Dec. 9, 1967).
47. E. R. Humphreys, Preparation of an Oligoguluronide from Sodium Alginate, *Carbohydrate Res.*, **4**: 507-509 (1967).
48. Y. Tanaka et al., Studies on Inhibition of Intestinal Absorption of Radioactive Strontium. VII. Relationship of Biological Activity to Chemical Composition of Alginates Obtained from North American Seaweeds, *Can. Med. Ass. J.*, **99**: 169-175 (1968).
49. T. E. F. Carr, G. E. Harrison, E. R. Humphreys, and A. Sutton, Reduction in the Absorption and Retention of Dietary Strontium in Man by Alginate, *Int. J. Radiat. Biol.*, **14**(3): 225-233 (1968).
50. V. Nigrović, Enhancement of the Excretion of Radiocesium in Rats by Ferric Cyanoferrate (II), *Int. J. Radiat. Biol.*, **7**: 307 (1963).
51. V. Nigrović, Retention of Radiocaesium by the Rat as Influenced by Prussian Blue and Other Compounds, *Phys. Med. Biol.*, **10**: 81 (1965).
52. K. Madshus, A. Stromme, F. Bohne, and V. Nigrović, Correspondence-Diminution of Radiocaesium Body-Burden in Dogs and Human Beings by Prussian Blue, *Int. J. Radiat. Biol.*, **10**(5): 519-520 (1966).
53. Kjell Madshus and Aksel Strømme, Increased Excretion of ^{137}Cs in Humans by Prussian Blue, *Z. Naturforsch.*, **23b**(3): 391-392 (1968).
54. Public Health Service, Full-Scale System for Removal of Radiostrontium from Fluid Milk, Environmental Health Series, PHS Publication No. 99-RH-28, October 1967.
55. R. O. Marshall, E. M. Sparling, B. Heinemann, and R. E. Bales, Large Scale Fixed Bed Ion-Exchange System for Removing Iodine-131 and Strontium-90 from Milk, *J. Dairy Sci.*, **51**(5): 673-678 (1968).
56. R. W. Dickerson, Jr., A. L. Reyes, G. K. Murthy, and R. B. Read, Jr., Development of a Pulsed-Bed Ion Exchange Contactor for Removing Cationic Radionuclides from Milk, *J. Dairy Sci.*, **51**(8): 1317-1324 (1968).
57. R. F. Reitemeier, P. E. James, and R. G. Menzel, Reclamation of Agricultural Land Following Accidental Radioactive Contamination, in *Protection of the Public in the Event of Radiation Accidents*, Proceedings of WHO/FAO/IAEA Seminar, Nov. 18-22, 1963, Geneva, World Health Organization, Geneva, 1965.
58. Agricultural Research Service, Protection of Food and Agriculture Against Nuclear Attack, USDA Handbook No. 234, p. 10, 1962.
59. W. J. Lacy, Civil Defense and Municipal Utilities, *Municipal South*, **9**(3): 19-25 (March 1962).
60. C. P. Straub, Removal of Radioactivity by Water-Treatment Processes, in *Low-Level Radioactive Wastes*, pp. 155-202, Superintendent of Documents, U. S. Government Printing Office, Washington, D. C., 1964.

SENSITIVITY ANALYSIS OF AGRICULTURAL DAMAGE ASSESSMENT

STEPHEN L. BROWN

Stanford Research Institute, Menlo Park, California

ABSTRACT

This paper discusses the sensitivity of conclusions drawn from damage-assessment studies of fallout effects on agriculture to variations in the assumptions, parameter values, and models used. Among the parameters analyzed for sensitivity were the assumed date of nuclear attack; the type, weight, and efficiency of the attack with respect to agriculture; the season over which feed and food crops were assumed to be vulnerable; the lethal and threshold dose criteria; the dose-rate multiplier; and the beta-to-gamma dose ratio (which is, in turn, influenced by foliar retention, time of arrival, and the soil-roughness attenuation factor). The sensitivities are compared both qualitatively and quantitatively.

The Office of Civil Defense (OCD) is continually faced with decisions about how to allocate its scarce resources to best serve its mission, which, in highly simplified terms, is to make preparations that would lessen the impact of nuclear war on the nation if an attack should in fact occur. The allocations must be made in such a way that the net estimated improvement in the nationwide postattack situation is maximized, no matter what budget level OCD may designate. Allocations both for plans and operations and for research are affected by such considerations. A major purpose of the National Entity Survival (NES) studies is, therefore, to identify the elements of the national entity that are most vulnerable so that additional research or operational preparations in those areas will be of most benefit to the nation. The emphasis, as mentioned previously, is on the long-term national benefit, whether or not the short-term benefits would seem to accrue preferentially to some specific localities or some special-interest groups. In this context the NES approach is, in effect, a large-scale sensitivity analysis in which many smaller-scale analyses are embedded.

The agriculture part of the NES is, therefore, undertaken to assess the vulnerability of agriculture relative to other elements of the national entity and,

within the sphere of agriculture, to identify the most vulnerable factors and the most sensitive uncertainties. A clearly identified vulnerability would be a subject for operational preparations, whereas a highly sensitive uncertainty would be a candidate for additional research funds.

Agricultural damage assessment, which is concerned with estimating the magnitude of agricultural damage in comparison with damage to other segments of the national entity, is accomplished by operating on a set of basic agricultural data with a mathematical model of attack effects based on a hypothetical attack pattern. The agricultural data are usually reasonably accurate for the year in which they were acquired, but they become less representative as time goes on. The attack pattern can be considered a pure assumption, and the structure of the mathematical model is only a highly simplified representation of reality, having parameter values which are set by using the best empirical or theoretical knowledge available but which may be badly in error.

Because so many possibilities exist for introducing errors into a damage-assessment calculation, the conclusions reached about the relative vulnerability of agriculture vis-à-vis other elements of the national entity are always uncertain. The degree of uncertainty in the conclusions is affected by the degrees of uncertainty in the input assumptions, and the quantification of these relations constitutes a sensitivity analysis.

Sensitivity analyses can generally be carried out in either of two ways. The brute-force method repeats all the model computations for each of the permissible values of each parameter. This method is attractive because of its simplicity and unambiguity. When the computational scheme is complex and the number of parameters large, however, the brute-force method becomes rather unwieldy and expensive. A sophisticated method, on the other hand, operates on the partial derivatives of the computational output with respect to each input parameter, evaluated at the standard values of each parameter and at other selected parameter sets. This method has the virtues of elegance and of the ability to dispense with many computational details necessary in the brute-force method. This approach depends on expressing the input data and mathematical relations in reasonably analytic form, however, and becomes increasingly cumbersome as the number of discontinuities and ranges of validity* become large. The agricultural problem is characterized both by tabular data not analytically determined and by multiple ranges of validity.

A compromise approach can be taken to meet the challenge of these difficulties. Basically the brute-force method can operate on a much simplified set of data and computational procedures. The parameters can be varied in only two or three steps, e.g., "standard" and "worst-case" values. The standard values, at least at the time they are first set, should be the most probable values, perhaps with a somewhat conservative bias. The worst-case values are much more difficult to set, and undoubtedly an "even worse" value for some will eventually

*These are branches in the computation.

be found. However, an attempt should be made to choose values that would be the worst with, say, about 90% confidence, although such probability assignments are clearly no more than intuitive.

AGRICULTURAL DAMAGE ASSESSMENT

In this section agricultural-damage-assessment models and the data bases upon which they operate are reviewed. A detailed description of this damage-assessment system has been reported before,¹ and only the most general features are described here.

Basically the purpose of agricultural damage assessment is to predict the capability of the United States to produce food crops and livestock during the year following a hypothetical nuclear attack. The scope of the study is limited to the direct effects that fallout radiation has on this capability. Neither the farm losses due to lack of input resources, such as petroleum, agricultural chemicals, and seed, nor the more subtle effects of degraded management capabilities are considered in this discussion. Furthermore, nothing is implied about the state of the food-processing and distribution functions.

Thus the data base consists of the amounts of food and feed crops and the livestock herds produced in one year. The base year for these studies is 1959; the Census of Agriculture for 1959 reports the number of harvested acres for food and feed crops and the number of animals on farms for every county in the United States.² Only the major crop and livestock categories were used in the studies reported here—the term “major” being defined principally in terms of caloric value. A summary of the data base as stored on magnetic tape is shown in Table 1.

In the standard damage assessment, the data base is processed county by county, and the surviving quantities of resources are cumulated by state, region, and nation. As pointed out earlier, however, this procedure is virtually impossible for sensitivity analyses. To surmount this difficulty, we placed the data for each resource category in rank order according to the concentration of the resource (acres harvested per unit area of the county or number of head of livestock per unit area). We then totaled these to form a cumulative distribution function showing the percent of a year's production grown as a function of the percent of the U. S. area represented by the producing counties. Figure 1 is an example of such a distribution function for soybeans. Functions were also established in the same manner for only those acres on which crops were growing and were vulnerable on the postulated date of attack (June 15). (See Ref. 3 for a more detailed discussion.)

All the agricultural resources studied yielded cumulative distribution functions very similar to those in Fig. 1, and each could be reasonably well represented by the analytic function

$$f_v = \alpha (1 - e^{-\lambda f_a}) \quad (1)$$

Table 1
AGRICULTURAL DATA BASE

Livestock*		Crop†			
Chickens	11‡	Corn	21	Alfalfa	42
Hogs and pigs	12	Sorghum	22	Potatoes	50
Milk cows	13	Winter wheat	23	Green peas§	51
Bulls, steers, and calves	14	Spring wheat	24	Sugar beets	56
Sheep and lambs	15	Winter oats	25	Tomatoes§	57
		Spring oats	26	Sweet corn	61
		Winter barley	27	Snap beans§	64
		Spring barley	28	Cabbage§	68
		Rice	29	Dry onions§	72
		Dry beans§	31	Carrots§	73
		Soybeans	32	Lettuce§	76

*Each record contains a region-state-county code, the national location code, the latitude and longitude of the "center" of the county, the area of the county, and the numbers of animals.

†Each record contains a region-state-county code, the national location code, the latitude and longitude of the "center" of the county, the crop number code, the number of acres harvested, the yield per acre in tons, the normal planting and harvest dates, and the area of the county.

‡Numerical code for resource is used for identification.

§ These items were used in the sensitivity analysis but not in the basic damage assessment.

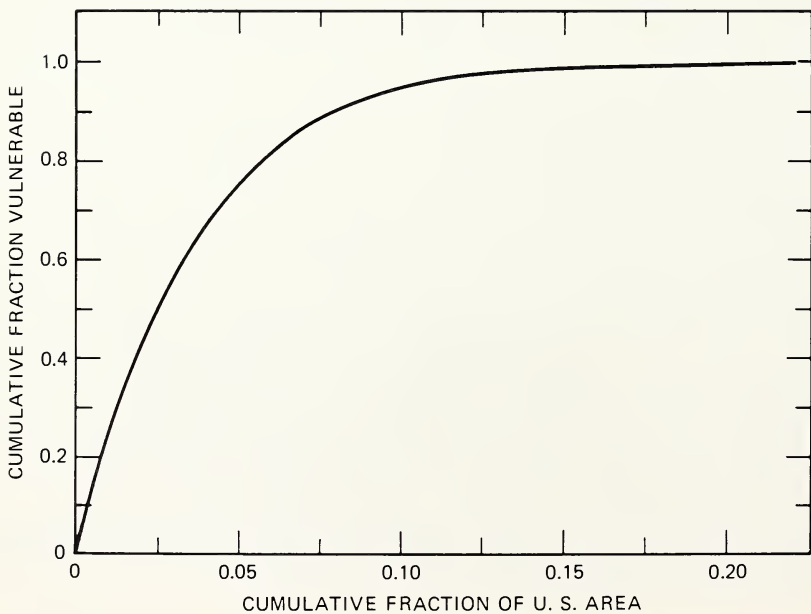

Fig. 1 Cumulative vulnerability of soybeans.

where f_v is the cumulative fraction of the resource vulnerable and f_a is the associated cumulative fraction of the U. S. area. The parameters α and λ vary with the resource; α is unity if the entire crop is assumed vulnerable but is less if only the growing crop is vulnerable on the date of attack, and λ is a measure of the concentration of the resource.

In the standard damage assessment,¹ the assumed attack pattern is processed by a fallout-prediction system to yield the standard intensities, accumulated doses, and times of arrival of the fallout at thousands of standard locations throughout the nation. These are related to the counties in which they appear, and the crop or livestock resource is then assumed to be exposed to a corresponding distribution of gamma doses. The dose and intensity distributions are further processed to determine a distribution of entry times at which farmers can resume tending their crops. If a planting or harvest date is missed, then the possible fraction harvestable is reduced accordingly.

The gamma doses are also compared with the lethal doses (LD_{50}) for the livestock herds; the entire herd is assumed to be lost if the dose exceeds the LD_{50} and to survive if it is lower. The total dose to crops is compared with a

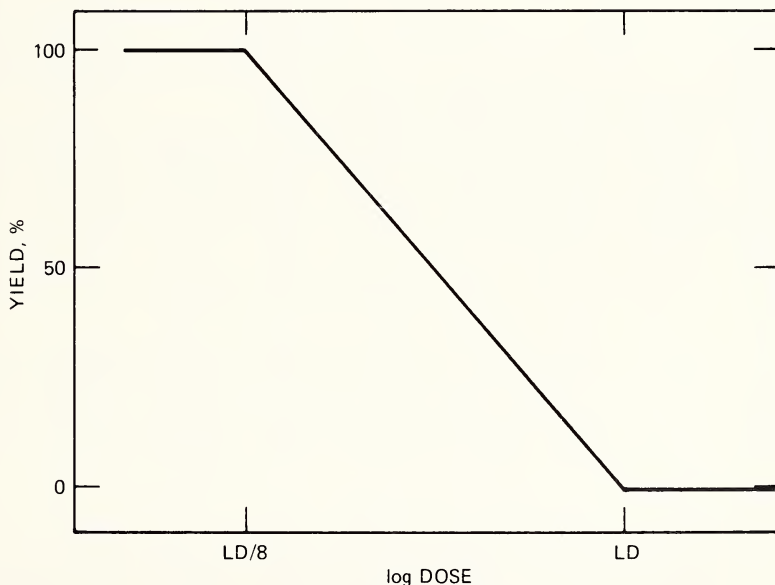

Fig. 2 Reduced yield.

survival curve (Fig. 2) determined by two parameters, lethal dose (LD_{100}), above which no yield survives, and threshold dose ($LD/8$), below which 100% yield is obtained. Selected lethal doses used are shown in Table 2. The total dose to crops is obtained from the gamma dose by application of a total-to-gamma dose ratio that accounts for the contribution of beta radiation to the total dose.

The total-to-gamma dose ratio depends on the time of fallout arrival and on several parameters of the plant and source geometries, including the size of the

Table 2
LETHAL DOSES

Crop	Rads
Most grains	4,000
Rice	20,000
Soybeans	14,000
Potatoes	12,500
Sugar beets	13,500

plant, the fraction of fallout retained on plant foliage, and the surface-roughness attenuation factor for beta particles. The size of the plant is characterized by the height and radius of a vertical cylinder. The radiation-sensitive tissue is assumed to lie at the center of the upper end of this cylinder, and doses are calculated at that point. The fraction of fallout retained on foliage is assumed to be a function of the density of plant matter at the time of attack; both this parameter and the radius and height of the cylinder depend on the plant's age at the time of attack. All the values for input parameters were selected on the best available data at the time, but many were no more than educated guesses.

One observation that is not particularly dependent on the exact specification of all the input variables is that beta dose is quite important for most crop plants, leading to total-to-gamma dose ratios considerably larger than 1. The total-to-gamma dose ratio can be written as

$$M_{\beta\gamma} = 1 + f_l R_{\beta\gamma} \left(\frac{h}{2} \right) + Q_\beta (1 - f_l) R_{\beta\gamma} (h) \quad (2)$$

where f_l is the fraction retained on foliage, Q_β is the soil-roughness attenuation factor, and $R_{\beta\gamma}$ is the ratio of beta-to-gamma doses above a smooth plane source. Selected values for $R_{\beta\gamma}$ as a function of radius, height, and time of arrival are shown in Table 3. The beta contribution will be negligible only if both $f_l \approx 0$ and $Q_\beta \approx 0$.

The surviving fractions of agricultural resources were adjusted by the possible fractions harvestable; these were cumulated and expressed as a fraction of the normal annual yields. Selected results for a medium-weight (1300-Mt) counterforce attack are shown in Fig. 3. The values shown include both beta- and gamma-dose damage as well as losses due to denial of entry to farmers. Individual figures are also available.

In general, the surviving fractions indicate that agriculture is approximately as vulnerable as population (about 80% survived this attack). The balance in survival fractions is also relatively good, and the overall postattack agriculture picture appears better than for many other elements of the national entity.

Table 3
BETA-TO-GAMMA DOSE RATIOS

Arrival time	Radius, cm	Height of 0.3 cm	Height of 10 cm	Height of 300 cm
15 min	0.1	33	18	2.6
	0.3	14	7.8	1.5
	1.0	1.2	0.8	0.2
16 hr	0.1	22	12	1.0
	0.3	5.6	3.2	0.5
	1.0	0.4	0.3	0.1

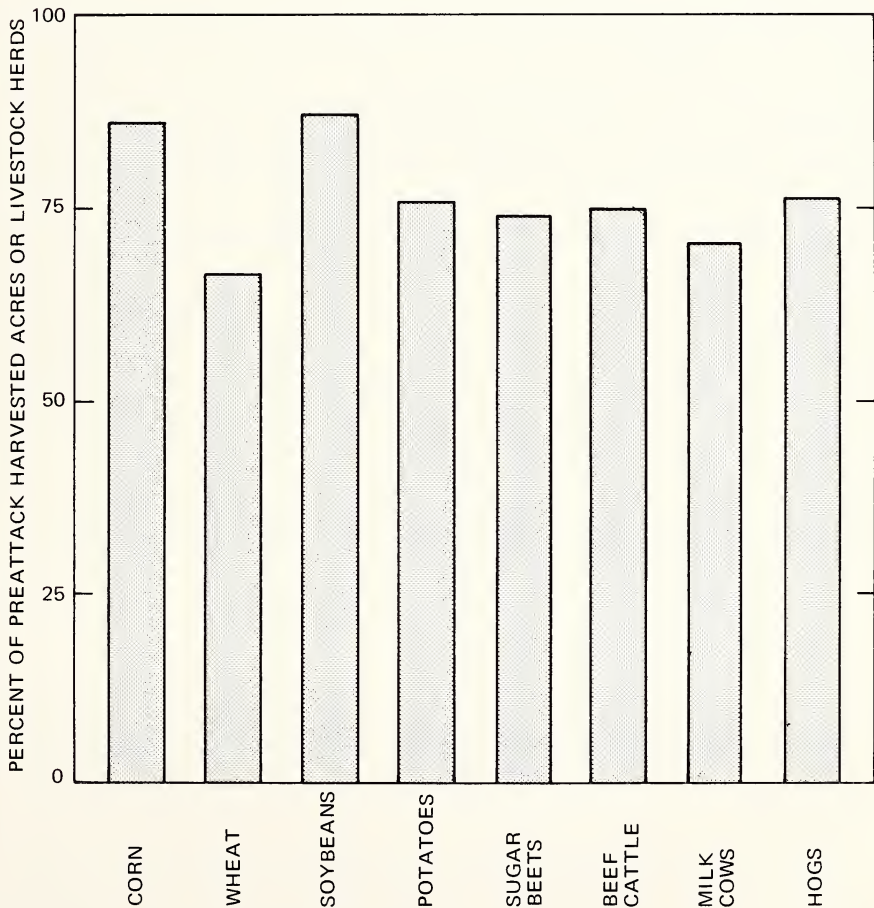

Fig. 3 Survival of major crops and livestock (Attack SRI A).

These conclusions, however, are not necessarily any more certain than the input parameters and assumptions were. As was mentioned, the uncertainties in input parameters are often quite large, and it is not unreasonable to voice concern over the validity of the output results. The sensitivity analyses reported in the next section were performed to test the effects of uncertainties in inputs on uncertainties in outputs.

SENSITIVITY ANALYSES

Perhaps the most obvious uncertainty is when the attack should be assumed to occur. A conservative assumption is that the attack occurs at the time of maximum vulnerability for agricultural resources. This will surely be during the growing season, and perhaps rather early in the season because of the increased beta vulnerability of young plants. Therefore June 15 was chosen as the date of attack for the standard damage assessment. A brute-force analysis was undertaken, to test the validity of this assumption, and the entire assessment was run over again for a series of the attack dates. To reduce the effort to a manageable level, only the results for OCD Region 6 were obtained; these⁴ are shown in aggregated fashion in Fig. 4. Survival is never 100%, because some

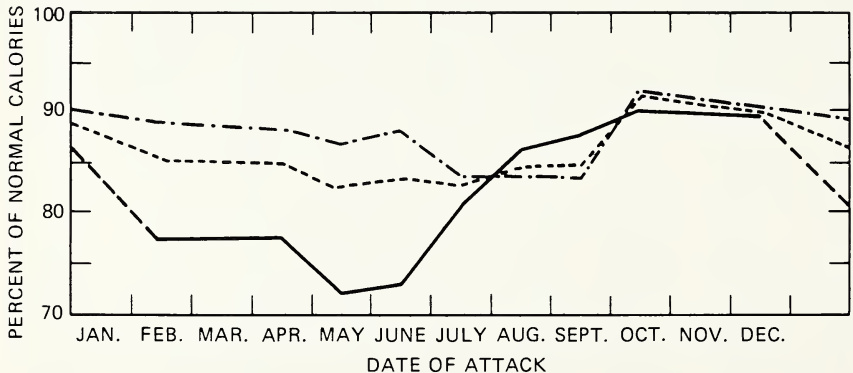

Fig. 4 Total food value, Region 6. —, human calories; ····, animal calories; ---, total calories.

farmers are killed and never gain access to their crops. The variation in radiation sensitivity over the year, however, does lead to decreased survival during the period from May to September, and June 15 appears to be as conservative as any assumption.

Because the total-to-gamma dose ratio ($M_{\beta\gamma}$) is so important to the calculation and because many of the parameters determining it are not well known, an analysis of the variation of $M_{\beta\gamma}$ with the fraction of fallout retained on foliage and the soil-roughness attenuation factor was conducted. Equation 2

was computed for several reasonable values of the height and radius of the plant stem and for several times of arrival, assuming $Q_\beta = 0.5, 0.2, \text{ and } 0.1$ and $f_l = 0.01, 0.03, 0.1, 0.3, \text{ and } 1.0$. Typical results are shown in Fig. 5, which indicates that misestimation of either Q_β or f_l over fairly wide ranges would lead to misestimates of $M_{\beta\gamma}$ by a factor of 2 or less. A concurrent investigation

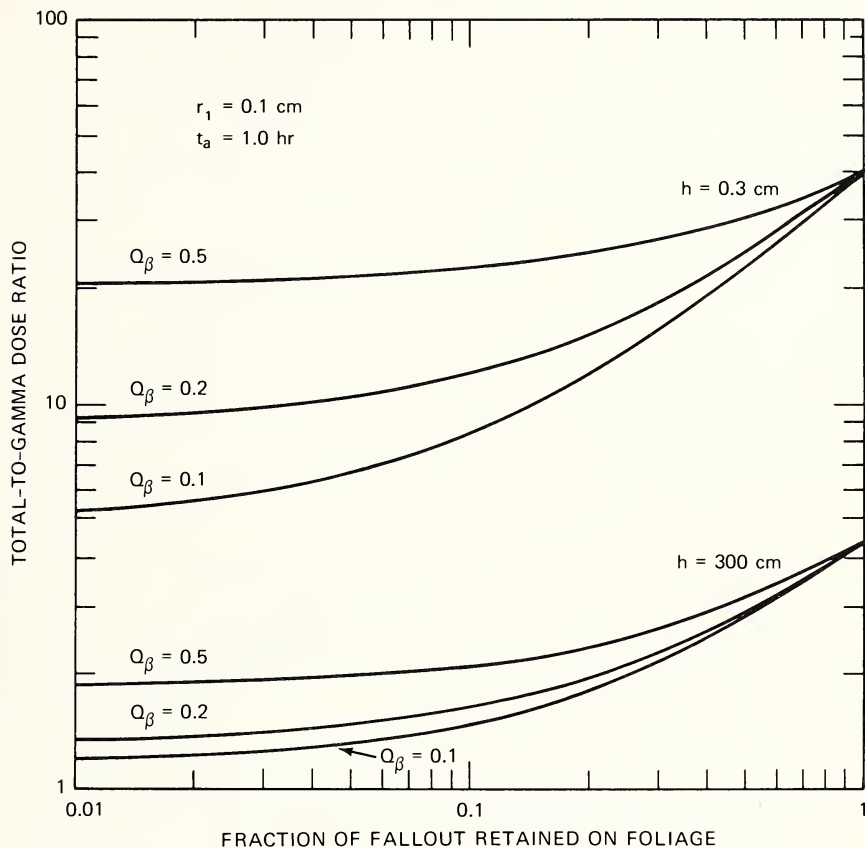

Fig. 5 Variation of the total-to-gamma dose ratio.

assessing the effect of the assumed distribution of the fraction retained on foliage revealed that again the model currently in use (which assumes that the foliar fraction is all deposited on a plane at height $h/2$) reasonably represents $M_{\beta\gamma}$ for most combinations of the parameters. (See Ref. 4 for a more detailed discussion.)

The principal sensitivity analysis summarized here tested the effect of the assumptions in Table 4 for standard and worst-case values.³ The damage-assessment model was highly simplified, and the agricultural resource distributions represented by the functions of Eq. 1 were used. The $f_a(W,I)$, the fraction

Table 4
PARAMETERS OF THE SENSITIVITY ANALYSIS

Parameter	Symbol	Assumptions
Type of attack	IAT	Counterforce Mixed
Weight of attack	W	100, 200, 400, 700, 1000, 2000, 4000, 7000, 10,000, 20,000, 40,000, 70,000, and 100,000 Mt
Season of vulnerability	ISV	Vulnerable (standard) Growing Year (worst case)
Efficiency of attack	E	Random (standard) Maximum (worst case)
Lethal dose	D_l	D_l rads (standard) $D_l/4$ rads (worst case)
Dose-rate multiplier	M_t	2.0 hr (standard) 3.33 hr (worst case)
Total-to-gamma dose ratio	$M_{\beta\gamma}$	$M_{\beta\gamma}$ (standard) 2 $M_{\beta\gamma}$ (worst case)
Lethal-to-threshold dose ratio	R	Crops: 8 (standard) 16 (worst case) Livestock: 1 (standard) 2 (worst case)

of the U. S. area covered by fallout of a given attack weight (W) and standard intensity (I), was as computed by Miller⁵ for counterforce and mixed attacks. If an attack fallout pattern is random with respect to a given agricultural resource, the probability of damage, f_v^r , at a given level, intensity, and yield is just equal to the total fraction of the resource vulnerable (α) times the fraction of the area covered (f_a). However, if the attack pattern is of maximum efficiency against the resource, the area of growing crops or livestock can be covered with a much smaller W for a given I. In this case the fraction vulnerable to damage is given by

$$f_v^m = \alpha(1 - e^{-\lambda f_a(W, I)}) \quad (3)$$

The dose delivered by standard intensity I is given by

$$D = M_{\beta\gamma} M_t I \quad (4)$$

where $M_{\beta\gamma}$ is the total-to-gamma dose ratio and M_t is the dose-rate multiplier that converts gamma dose rate to gamma dose on the basis of time of arrival and period of exposure. The total fraction damaged is then given by

$$f_k = \int_0^\infty k \ln \frac{I}{I_t} \frac{df_v}{dI} \tag{5}$$

where k and I_t (the threshold intensity) can be computed from Eq. 4 and the analytic expression for Fig. 2.

This fraction was computed for each of the assumptions in Table 4, and typical results plotted as a function of weight of attack are shown in Fig. 6.*

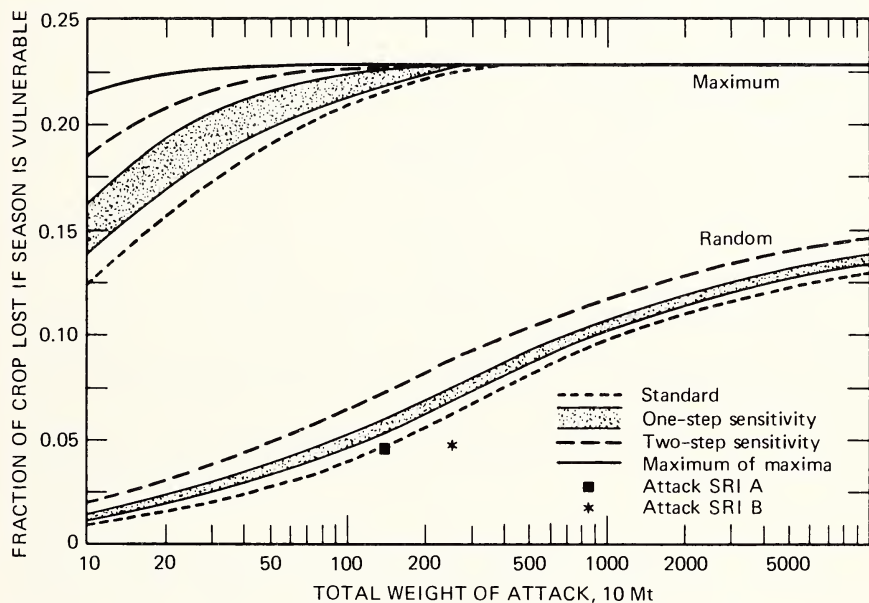

Fig. 6 Fraction of annual production lost for corn.

“One-step sensitivity” implies that only one of the last four parameters took on its worst-case value, whereas “two-step sensitivity” implies that two did. The results are for a counterforce attack, which usually produces more fallout than a mixed attack of the same weight because of a larger fraction of surface bursts. The relative sensitivities of various combinations of parameters are shown in Table 5, which demonstrates that uncertainties in D_I or $M_{\beta\gamma}$ are equally troublesome but that the likely spread of M_t produces less uncertainty in f_k and that the lethal-to-threshold dose ratio is least sensitive of all. None of these

*Also shown are comparable results from the standard damage assessment. Attack SRI A is a counterforce attack, whereas SRI B is a mixed attack (see Ref. 1).

Table 5
RELATIVE SENSITIVITIES OF VARIOUS COMBINATIONS
OF PARAMETERS

Lethal dose	Lethal-to-threshold ratio	Total-to-gamma dose ratio	Dose-rate multiplier	Code*
Standard	Standard	Standard	Standard	01
Standard	Worst	Standard	Standard	02
Standard	Standard	Standard	Worst	03
Standard	Standard	Worst	Standard	04
Standard	Worst	Standard	Worst	05
Standard	Worst	Worst	Standard	06
Standard	Standard	Worst	Worst	07
Worst	Standard	Standard	Standard	08
Standard	Worst	Worst	Worst	09
Worst	Worst	Standard	Standard	10
Worst	Standard	Standard	Worst	11
Worst	Standard	Worst	Standard	12
Worst	Worst	Standard	Worst	13
Worst	Worst	Worst	Standard	14
Worst	Standard	Worst	Worst	15
Worst	Worst	Worst	Worst	16

*Code numbers above 08 are less sensitive; those below are more sensitive.

uncertainties are very sensitive, however; the maximum one-step uncertainty yields about 8% uncertainty in f_k for attack weights in the 1000- to 3000-Mt range.

The variation of f_k with W is much more significant; in the region between about 1000 and 10,000 Mt, the value of f_k rises comparatively steeply for the random-attack assumption. The question of whether efficient attacks against agriculture are credible is the most sensitive assumption; the fraction lost can vary from near zero to near unity depending on this assumption. Several facts argue against the efficient attack, however, e.g., the difficulty of picking appropriate targets for any fallout attack because of uncertainties as to wind speeds and direction. Concentration of fallout in just those counties with concentrations of agricultural resources is, in fact, impossible. Perhaps most important, however, is that attacks aimed at specific elements of the national entity can find much more vulnerable target sets than agriculture. For instance, the petroleum-refining capacity is highly concentrated, and, if it were attacked, agriculture would be damaged just as surely as if it had undergone a direct fallout attack.

The assumption concerning the period over which crops are vulnerable is of intermediate sensitivity. The principal difference is in the fraction, α , vulnerable

at any one time. If the crop is vulnerable over the entire year, α is, of course, equal to one. If the period of vulnerability is the growing period or some fraction thereof, the value of α may be considerably less than one, or may even be zero, depending on the date of attack. A reasonably conservative assumption is to use the entire growing season.

In summary, the most sensitive assumption is whether or not the attack is efficiently aimed at agriculture. The probability that this would occur is considered to be very low. Next in sensitivity are the date of attack and the season of vulnerability. Conservative assumptions in these cases are to choose the entire growing season as vulnerable and to choose June 15 as the date of attack. Both weight and type of attack to assume are also important; a counterforce attack of maximum credible size is the most conservative. The vulnerability criteria (lethal doses) are of lower sensitivity, as are the total-to-gamma dose ratios. Because input parameters for calculating the latter are more likely to be uncertain, however, additional research on beta-dose effects appears slightly more profitable. The dose-rate multiplier is not a subject for further research, and the lethal-to-threshold dose ratio is least sensitive of all.

REFERENCES

1. Stephen L. Brown, Hong Lee, and Oliver S. Yu, Postattack Food Production and Food and Water Contamination, SRI Project No. MU-6250-050, Stanford Research Institute, June 1968.
2. U. S. Census of Agriculture, 1959, Counties, Farms, Farm Characteristics, Livestock and Products, Crops, Fruits, Values, Vol. 1, Parts 1-54, Superintendent of Documents, U. S. Government Printing Office, Washington, 1962.
3. Stephen L. Brown and Pamela G. Kruzic, Agricultural Vulnerability in the National Entity Survival Context, SRI Project No. MU-7979-001, Stanford Research Institute, July 1970.
4. Stephen L. Brown and Ulrich F. Pilz, U. S. Agriculture: Potential Vulnerabilities, SRI Project No. MU-6250-052, Stanford Research Institute, January 1969.
5. Carl F. Miller, Assessment of Nuclear Weapon Requirements for Assured Destruction, Report URS-757-6, URS Research Company, February 1970.

APPLICATION OF DAMAGE-ASSESSMENT DATA IN U. S. AGRICULTURAL DEFENSE PLANNING

BRUCE M. EASTON

Defense and Disaster Operations Division, Agricultural Stabilization and
Conservation Service, United States Department of Agriculture, Washington, D. C.

ABSTRACT

In making plans and developing programs to carry them out in the event of a nuclear war, we follow the principle of simulating postattack conditions as nearly as possible. The best simulated-damage-assessment data available are applied to every planning step.

Most damage-assessment data used in agricultural defense planning are prepared by computer at the National Resources Analysis Center of the Office of Emergency Preparedness (OEP). The USDA works with OEP on food and agriculture resources in this computer. Input data in the computer model on damage to crops and livestock come from you who are here at this symposium. We use your data as soon as you release it for use. We are looking forward to receiving and studying the proceedings of this symposium and to using the information whenever possible.

The U. S. Department of Agriculture (USDA) is charged by presidential executive order to prepare national emergency plans and to develop preparedness programs for food, crops, livestock, and other agricultural resources. For this paper, however, we will concentrate on crops and livestock, the subject of this symposium.

In making plans and developing programs to carry them out if a nuclear war occurs, we follow the fundamental principle of simulating postattack conditions as nearly as possible. For livestock, we give more attention to the early postattack conditions, the first 30 to 60 days. For crops, we give attention to both early and intermediate postattack conditions for several reasons, one being seasonal production cycles. Even the best of preparedness plans and programs would need to be altered postattack as actual conditions became known.

The best simulated-damage-assessment data available are applied to every planning step we take. Let us look first at the broad aspects of the simulated-damage-assessment process and then narrow it down to a more specific

example. Following this, we will look at the principal sources of damage-assessment data and then briefly at plans for doing actual damage-assessment work in a nuclear war if it should occur.

GENERAL APPLICATION OF DAMAGE-ASSESSMENT DATA

We all know that the objective of postattack agriculture is to produce sufficient crops, livestock, poultry, and other products to meet requirements. We begin our planning efforts by trying to ascertain the probable postattack demand for agricultural commodities to feed the surviving U. S. population at a diet level as nearly normal as possible and with some degree of nutritional balance. This is where we first come face-to-face with the application of damage-assessment data in the planning. The first step is to determine the number of survivors to be fed. In actual operations we obtain these data through the Office of Civil Defense (OCD) and the Office of Emergency Preparedness (OEP), but this does not alter the fact that damage-assessment data are applied by these agencies.

Another major component of demand for agricultural products other than that for food is the requirement by industry. This, too, involves damage assessment to ascertain the postattack condition and needs of the industries. The last major component is exports to friendly countries. Of the three components, exports are least amenable to the application of damage-assessment techniques based on currently available information.

When we have a total-demand figure, we then look at agriculture's postattack capability to produce adequate supplies to meet that demand. In doing so, we examine as thoroughly as possible the resources essential for agricultural production to see what would happen to them in a nuclear attack. In short, we apply damage-assessment techniques to them. We examine what would likely happen to farmers, meat animals, milk cows, poultry, feed, pasture, and other agricultural production and distribution resources.

Specific Example

Fairly detailed studies of these resources are made. For example, let us look briefly at feed for livestock and poultry and review the main steps we take to develop an analysis.

1. We begin with the surviving population as the basis of demand for meat and poultry and their products. This establishes the potential demand for the consumers of feed.

2. We then determine the probable postattack status of each major kind of livestock and poultry to provide a measure of the capability to feed surviving people and to indicate requirements for different kinds of livestock and poultry feed.

3. We estimate the status of rural farm population and the time required for radiation to cool to a point where farmers could care for their livestock and poultry.

4. We determine probable stocks of feed and food grains remaining in relation to requirements. Any grains may be used for food or feed purposes in an emergency.

5. We also determine probable availability of other feed inputs such as protein meals and milling by-products. This is done by estimating attack effects on oil and grain mills.

6. We examine the intensity of fallout on forage crops and pasture lands to project the availability of pastures, hay, and other roughages.

7. We ascertain the likely remaining capacity of the feed-manufacturing industry and project by time periods when fallout would cool enough for this capacity to be safely operated.

8. Then we look at the probable time-phased availability of transportation to move grains and other feed ingredients to feed mills and feed mill outputs to customers. Transportation is a critical factor in the availability of feed.

We feel that we must know at least this much about the major factors relating to feed before we can develop a practical standby program that would be effective after a nuclear attack. We follow similar procedures for the other resources under the jurisdiction of the USDA.

Some of the resources to which damage assessment is applied are under the jurisdiction of other federal agencies; transportation is an example. Our studies of these resources are made in cooperation with other agencies. Also, some resources, like fuels and pesticides, have multiple uses. We need to know not only what happened to these multiple-use resources as a whole but also what would be agriculture's probable share of the remaining postattack supply.

SOURCES OF DAMAGE-ASSESSMENT DATA

Most damage-assessment data used in agricultural defense planning are prepared by computer at the National Resources Analysis Center (NRAC) of the OEP. As you may know, most of the nation's important resources are programmed in NRAC's computer. This includes not only food and agriculture but also such other resources as population, manpower, manufacturing, fuels and energy, transportation, and wholesale and retail trade. The agricultural production resources include beef cattle, milk cows, swine, sheep and lambs, chickens and broilers, several major crops, cropland, pasture, and grain-storage facilities. These preattack-resource data are run against various types of simulated attack patterns, and computer printouts are prepared to show the estimated nuclear attack damage to these resources.

The USDA works with the OEP in maintaining an up-to-date file on food and agriculture resources and in developing programs required to project the

availability of these resources under emergency conditions. A preattack inventory of agricultural resources is maintained in the NRAC computer file. The latest Census of Agriculture is the primary source of data for crops and livestock. These data are entered by county and subdivided by census tracts or Standard Location Areas, which are primarily minor civil divisions in rural agricultural areas.

In assessing probable damage to crops, we have used thus far the cumulative outside radiation dose and analyzed the denial-time effect on people. This means that we estimate when fallout radiation will cool sufficiently to allow farmers to work their land on a full- or part-time basis without being subjected to serious radiation damage. The projected damage to growing crops is based on the effect of this denial time for the designated season of the year. We use this because we do not have sufficient research information on the effects of fallout radiation on crops to apply in our damage-assessment work.

However, a more sophisticated technique has been developed for assessing attack damage to livestock and poultry. It includes the following adjustment factors, which we have programmed into the NRAC computer:

1. Percentage distribution of preattack livestock and poultry numbers by type of shelter in major geographic areas.
2. Fallout attenuation (reduction) factors assigned to each type of shelter.
3. Mortality tables by kind of livestock and poultry, showing effects of various amounts of net gamma radiation exposure.

Many different types of attack patterns have been run against our crop and livestock data as well as other agricultural resources. The resulting computer printouts provide our main damage-assessment base for use in agricultural defense planning. Figure 1 shows the computer output format for livestock and poultry and Fig. 2 that for cropland harvested.

The livestock and poultry output format (Fig. 1) provides a computer estimate of the preattack number that will be killed or will die later and the number that will remain alive from a 96-hr radiation-exposure dose by the end of 7 days, 15 days, and 30 days following an attack. We use the number killed or destined to die by these time periods to project the number of animals and poultry located in areas accessible to a work crew by the indicated time period without their being subjected to serious radiation levels. There is no assurance, however, that such animals would be salvaged for human consumption.

Use of Research Data

No computer model can be designed and used effectively in the preparation of postattack-damage-assessment estimates unless substantial use is made of research results. Our mortality tables, for example, are based entirely on research findings. But we need a broader range than $LD_{50/30}$ (a 50% lethal gamma dose in 30 days). We also need LD_{50} for 7- and 15-day periods and an LD_{25} and LD_{75} for all three periods. In addition, we need research data on the internal

Kind of livestock and poultry by State	Preattack total	Killed or will die on or before D + 7			Killed or will die on or before 30 days			
		Unavailable for salvage ¹	Available for salvage ¹	Total killed or will die	Unavailable for salvage ¹	Available for salvage ¹	Total killed or will die	Total survivors D + 30
#1. Milk cow inventory, number %								
#2. Cattle sold, number %								
#3. Calves sold, number %								
#4. Hogs and pigs sold, number %								
#5. Sheep and lambs sold, number %								
#6. Chickens sold, number %								
#7. Chickens, 4 months old and over, number %								

¹ Availability for salvage depends on gamma radiation effect on work crew.

Fig. 1 Computer-output-summary format, by states, for livestock and poultry.

	Available for use D + 1	Available for use D + 2	Available for use D + 5	Available for use D + 10	Available for use D + 15	Available for use D + 30	Available for use D + 60	Available for use D + 90	Available for use D + 365
Preattack total									
COUNTIES, ¹ number									
%									
acres									
%									
COUNTIES, ¹ number									
%									
acres									
%									
COUNTIES, ¹ number									
%									
acres									
%									

¹ Each block represents a separate State.

Fig. 2 Computer-output-summary format, by states, for cropland harvested.

and external effects of beta radiation as well as the combined insult of gamma and beta to livestock. We are aware of the research now in progress and look forward to using the results as soon as we are told that we can do so.

Our computer model is built in sections to permit the use of revised data each time new research findings are established. When research findings indicated, for example, that an attenuation of 0.7 should be used for unsheltered animals instead of 1.0, this change was reflected in the computer program. If we can obtain better data on the preattack distribution of livestock and poultry inventories by type of shelter or on the protection factors provided by these shelters, these adjustments can be entered directly into the computer model.

We are especially looking forward to research results that we can use to reflect the effects of gamma and beta radiation on crops. As previously mentioned, we are now applying to crops the effects of delay time resulting from cumulative outside radiation dose on farm labor. As soon as adequate data are available from current research on crops, it will be programmed into the computer model, and we will take a keen look at the outcome in relation to our preparedness plans.

APPLYING DAMAGE ASSESSMENT FOLLOWING A NUCLEAR ATTACK

In addition to applying estimated-damage-assessment data in defense planning and in test exercises, the USDA is prepared to assess actual damage in the event of a nuclear war. That assessment would include crops and livestock as well as food processing, storage, and distribution and other related resources for which USDA is responsible. This assessment would be time phased, with the earliest estimates based on a combination of incomplete information and preattack analysis prepared for planning purposes. As additional information became available, including a periodic series of postattack field reports covering actual observations, these initial estimates would be improved until the actual situation was known.

Very soon after an attack, designated USDA personnel at the national level and similar personnel working with USDA state defense boards would prepare an analysis of the nature and scope of the attack. Instructions for use in completing this assignment at the state level are already pre-positioned there. Information assembled on the nature and scope of attack will be manually related to pre-positioned resource data by commodity specialists for the purpose of producing initial assessment of the remaining resources. To the extent that NRAC estimates of remaining resources can be prepared and distributed on a timely basis in a postattack situation, these data will be used to supplement manual damage estimates prepared by USDA, particularly at the national level. Our assessment of remaining resources will be revised and updated as additional information is made available and used as a base in carrying out the department's emergency assignment.

County defense boards have pre-positioned instructions to make actual observations of the attack situation as soon as the radiation situation would allow and to submit to state defense boards periodic reports of two general kinds: One provides information on the attack status, e.g., the rural fire situation, the fallout situation, and the presence of any biological- or chemical-warfare agents. The other provides information on USDA operating capability in states and counties and on resources, such as food stocks, food processing and storage facilities, and agricultural production.

Crop- and livestock-damage data would be included in the agricultural-production report series as a percentage of the preattack total in each county. The state agricultural statistician would apply these percentages to the latest preattack inventory estimate to determine the postattack status of these commodities in the state. In like manner, all other county reports would be summarized for use by the state defense board in making emergency decisions. State summaries would be periodically reported to national headquarters by the most efficient means of communications available for use in improving our national estimates of the attack situation.

SUMMARY

In summary, the USDA applies the best simulated-damage-assessment data available to every step of planning on crops and livestock. Research data are used promptly and directly. We need additional data and are looking forward to receiving the results of research now in progress. We are prepared to do actual damage assessment at the local level in the event of a nuclear attack.

UNITED KINGDOM CONSIDERATIONS IN AGRICULTURAL DEFENSE PLANNING

W. T. L. NEAL

Ministry of Agriculture, Fisheries and Food, London, England

ABSTRACT

The food-supply situation in the United Kingdom for 2 to 3 years postattack is examined. In the absence of imports and assuming a surviving population of 40 million (i.e., about 75% survival), a severe food shortage would exist.

Attention is drawn to the severe limitation on accurate assessment owing to a lack of knowledge about the beta-radiation contribution to the total radiation damage to crops and livestock from fallout.

In this paper the situation that would face the United Kingdom following a nuclear attack is set forth as objectively as possible. The basic data on which these conclusions are reached, such as the possible levels of contamination of foodstuffs and the effects of radiation on crops and livestock, are common to the situation of both the United States and the United Kingdom. There are, however, a number of other features that make the situation in the United Kingdom different from that in the United States, so much so that a different set of priorities would exist in the two countries.

THE PROBLEM

Any assessment of the effect of a nuclear attack on the United Kingdom's food resources over a 2- to 3-year period after an attack involves assumptions about the following factors:

1. The nature of the attack.
 - a. The number, distribution, and magnitude of the weapons burst.
 - b. Whether each weapon is airburst or ground burst.

- c. The meteorological conditions prevailing at the time of attack, including particularly the wind force and wind direction at various heights above the ground surface.
2. The size of the surviving population.
3. The size of any food stockpiles, particularly of foodstuffs that are normally widely dispersed throughout the country and thus relatively invulnerable.
4. The extent to which dispersion of food stocks and other ameliorative measures, such as putting animals under cover, can be effected.
5. The effect of fallout radiation on livestock and crops.
6. The magnitude and time of recommencement of imports of food.

Let us consider these factors in more detail.

The Attack

The war-games enthusiasts can devise a number of different attack patterns ranging widely in severity and especially in the number of ground-burst weapons involved. A typical attack pattern I have examined resulted in the situation defined in Fig. 1, which shows the area of the United Kingdom within which the radiation dose rate at D + 2 days exceeds a certain value. Such a graph gives no indication of the geographical distribution of the fallout pattern, but this is not important in the context of this paper.

Surviving Population

Any assessment of the adequacy of food supplies must obviously be related to the size of the population to be fed. Estimates of surviving populations depend on attack patterns and many other factors. The more optimistic assessments suggest that 80% of the population will survive and the more pessimistic 50%. That is, the surviving population will be between 40 and 25 million, the higher figure being the more likely.

Existing Food Stocks

In peacetime the United Kingdom imports about 50% of the food it consumes. Much of this imported food is stored and processed either in the area immediately around the big ports or in the large cities. Distribution tends to take place directly from these areas. Intermediate depots hold only small supplies, probably sufficient for a week or 10 days, and rely on rapid and efficient transport to maintain their stocks.

The total stocks in the country at any time depend on a variety of factors and differ for different commodities, but for the basic staples, i.e., mainly wheat and meat, supplies at normal rates of consumption would last for little more than 2 months. If an attack came without warning and no steps were taken to

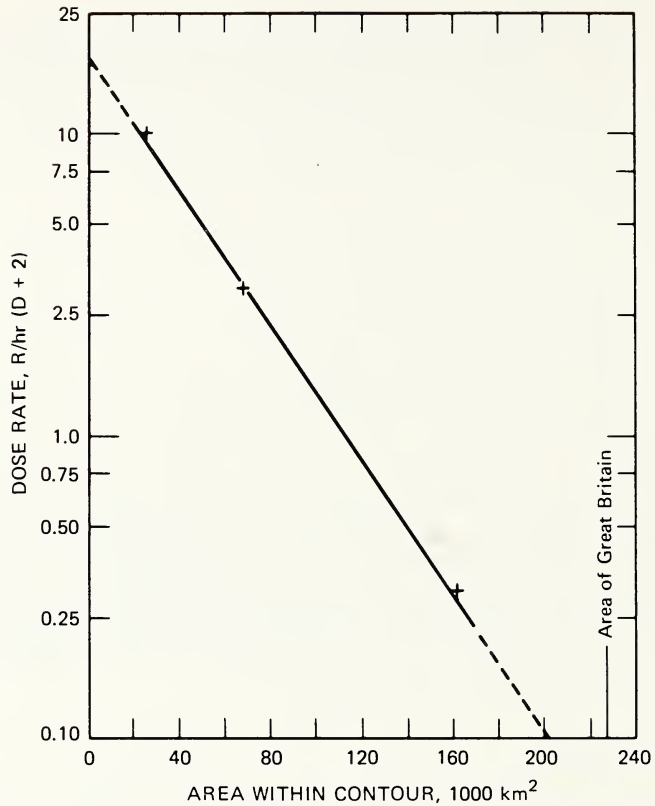

Fig. 1 Area of Great Britain within which the radiation dose rate exceeds a specified value.

conserve these food stocks, the bulk of the stockpile of food would be destroyed since the foodstuffs would undoubtedly be in target areas.

It is obviously desirable, therefore, to achieve dispersal of as much of these stocks as possible so that the probability of complete destruction is greatly reduced. Of course, the ideal situation would be for all the food available to be dispersed into every household in the land, and, although it is hoped that households would have on hand about a 2-weeks supply of food to tide themselves over the immediate postattack period, there are problems in achieving this desirable state of affairs.

Depending on the success of dispersal arrangements, more or less food would be available for the population. Most assessments suggest, however, that a greater proportion of food than of the population would be destroyed, so that in the end we should probably find that we had available perhaps between 1- and 2-months supply of food at normal rates of consumption.

Crops in Store

Until the next harvest we would have to rely on such crops as were in store and had survived the initial attack. In terms of calories these would be predominantly grains stored on farms and potatoes. About 10% of the grains are used for flour manufacture, 10% for distilling and brewing, and the rest for animal feed. Because these commodities are so widely dispersed, it is not expected that any appreciable proportion would be destroyed. I have assumed here that all such stocks would survive. Quantities available would vary from season to season. Table 1 shows the stocks of wheat and barley on hand at the

Table 1
COMPARISON OF CEREAL STOCKS WITH REQUIREMENTS TO PROVIDE
40 MILLION SURVIVORS 2000 Cal PER PERSON PER DAY

Month	Cereal required, million tons	Wheat on hand, million tons	Barley required, million tons	Barley on hand, million tons	Oats required, million tons	Oats on hand, million tons
September	7.2	2.9	4.3	6.0		
October	6.6	2.5	4.1	6.2		
November	6.0	2.2	3.8	5.2		
December	5.2	2.0	3.2	4.5		
January	4.6	1.6	3.0	3.5		
February	4.0	1.2	2.8	2.6		
March	3.2	0.9	2.3	1.7	0.5	0.3
April	2.6	0.6	2.0	1.1	0.9	0.2
May	2.0	0.3	1.7	0.6	1.1	0.1
June	1.4	0.1	1.3	0.25	1.0	0.05

end of each month from September to June along with the tons of cereal required to provide each member of a population of 40 million with 2000 Cal per day to the end of the following August. Note that, if the attack came after about the end of February, the existing grain stocks would be inadequate, even assuming that the barley available could be transformed into an edible and acceptable item of staple diet, such as a form of bread. Oat stocks are trivial and could make no significant contribution. Potato stocks are very variable since they depend on the potato market from year to year. In any event, it seems unlikely that potato stocks could provide more than 400 Cal per person per day, and in some years the contribution would be negligible.

The situation that would arise should the number of survivors be 25 million is shown in Table 2. Here a difficult situation could occur if the attack came in May or June.

Table 2

COMPARISON OF CEREAL STOCKS WITH REQUIREMENTS TO PROVIDE
25 MILLION SURVIVORS 2000 Cal PER PERSON PER DAY

Month	Cereal required, million tons	Wheat on hand, million tons	Barley required, million tons	Barley on hand, million tons	Oats required, million tons	Oats on hand, million tons
September	4.5	2.9	1.6	6.0		
October	4.1	2.5	1.6	6.2		
November	3.7	2.2	1.5	5.2		
December	3.3	2.0	1.3	4.5		
January	2.9	1.6	1.3	3.5		
February	2.5	1.2	1.3	2.6		
March	2.0	0.9	1.1	1.7		
April	1.6	0.6	1.0	1.1		
May	1.3	0.3	1.0	0.6	0.4	0.1
June	0.9	0.1	0.8	0.25	0.55	0.05

Table 3

ESTIMATED FALLOUT-RADIATION LETHALITY ($LD_{50/60}$)
FOR LIVESTOCK EXPOSED TO GAMMA RAYS*

Animal	In barns (gamma)	In pens or corrals (gamma + skin beta)	In pasture (gamma + skin beta + G.I. beta)
Cattle	500	450	180
Sheep	400	350	240
Pigs†	640	600	550

*According to Bell, Sasser, and West.¹

†Pigs do not normally forage in the open.

Surviving stocks from other sources, e.g., in the hands of millers, would be small and would probably be no more than those needed to compensate for the small loss of farm stocks that would inevitably result from the attack.

Livestock

Livestock would be affected by radiation from fallout. Animals in open fields would be exposed not only to gamma radiation from fallout but also to irradiation of the skin from particles adhering to it and to beta irradiation of the gastrointestinal (G.I.) tract from ingested fallout material. Estimations by Bell,

Sasser, and West¹ of the equivalent gamma-radiation dose corresponding to LD_{50/60} for animals exposed to gamma radiation alone, to gamma + skin beta radiation, and to gamma + skin + G.I. beta radiation are shown in Table 3. Assuming that the livestock population is uniformly dispersed geographically, the population would be reduced by the proportion of the country receiving radiation in excess of the appropriate LD₅₀ dose. (A reasonably accurate estimate of survivors is obtained by assuming that all animals receiving a dose greater than the LD₅₀ die and that all others survive.) Using the data in Fig. 1 and Table 3, we can calculate the surviving animal population. The results are shown in Table 4, together with the effect of putting the animal population

Table 4
LIVESTOCK SURVIVORS IN MILLIONS

Animal	Preattack population	Gamma exposure only	Gamma + skin beta + G.I. beta exposure	In shelters (protection factor of 2)*	In shelters (protection factor of 3)*
Dairy cows	4.6	3.1	2.5	3.6	4.0
Beef cows	6.2	4.2	3.3	4.8	5.4
Pigs	6.8	4.9	4.7	5.8	6.3
Sheep (June)	29.0	18.6	16.0	22.0	24.0
Sheep (December)	20.0	12.8	11.0	15.0	16.4

*Livestock in shelters would receive gamma exposure only.

under cover for protection from the beta effects and for a gamma-radiation protection factor of 2 or 3.

Pasture Requirement

In the United Kingdom a cow requires about 1 acre and a sheep $\frac{1}{5}$ acre of pasture to provide a maintenance diet for an adult animal or to provide for the growth of an immature animal. The pasture requirement will therefore range from 8.8 million acres for the lowest number of survivors shown in Table 4 to 14.4 million acres for the highest number. Currently the acreages of pasture in Great Britain are:

- 11.1 million acres of permanent grass
- 5.6 million acres of clover and rotational grass
- 17.0 million acres of rough grazing

These acreages can be expected to be reduced to 8.8, 4.5, and 13.6 acres, respectively, because of radiation damage, assuming that beta radiation doubles the effect of radiation dose. The amount of pasture available would therefore be adequate provided the additional effect of beta radiation did not increase the

effective radiation dose by a factor of more than 2 or 3. The pig population, of course, since pigs are direct competitors with man for grain, would have to be rapidly reduced. While this was taking place, our main meat ration would be pork and bacon for a considerable time.

Meat Yield

The amount of meat obtained from the various forms of livestock considered is shown in Table 5. The figures in column 3 are derived from the reproduction rates obtainable in peacetime. Using the animal survival figures given in Table 4, we can calculate that about 1 million tons of meat per year would be available (more if the animal population were to be decreased). This could give a ration of about 1 lb of meat per week (equivalent to about 1000 Cal per week) to each person of a population of 40 million survivors.

Table 5
MEAT YIELD PER ANIMAL

Animal	Yield, lb/animal	Yield,* lb/year
Dairy cow	350	100†
Beef	200	100
Pig	40	360‡
Sheep (June)	60	60
Sheep (December)	90	90

*Figures in this column are derived from the reproduction rates obtainable in peacetime.

†Some slaughtering of the dairy herd for meat is assumed.

‡The maximum is 360 lb/year. If the pig population is to be reduced, 40 lb/animal would be the more appropriate value.

Growing Crops

With the exception of pasture crops, none of the crops growing in the field at the time of the attack would be of any value as food until they were harvested. For our present purposes attention will be confined to the staples—wheat, barley, potatoes, and pasture, with pasture including “grass” for grazing, hay, and silage production. Losses of these crops can result from the following:

1. Direct physical destruction.
2. Loss due to interference with normal agricultural practice, e.g., weeding, spraying, etc.
3. Radiation damage.

Losses due to direct physical destruction and interference with normal agricultural practice are likely to be slight and are ignored here. Radiation damage, on the other hand, could be severe for some crops. Data on the effect of gamma radiation are now plentiful, and detailed assessments could be made using these data and particular fallout patterns. Unfortunately such assessments of themselves would be largely meaningless since they would fail to take into account the effect of the beta-radiation component from fallout. Estimates of the additional effect of beta radiation vary and will certainly differ for different crop species and times of the year. What is important from our point of view is to decide whether a knowledge of the effect of the beta-radiation component is vital to our assessment. The following simple example indicates that the factor limiting the precision of any assessment is, in fact, the effect of the beta component, and until this is resolved little purpose will be served by further refinement in our assessment of the gamma-radiation effect. In this assessment I have assumed:

1. Uniform geographic distribution of each crop so that the damage is related to the area of the country under the relevant levels of radiation dose.
2. A single radiation-dose-effect relation for each crop.

The justifications for such sweeping assumptions are: First, our assessment of the area of the country under given radiation dose levels is extremely crude, because of, among other things, uncertainties in the time of arrival of the fallout, and, second, these assumptions simplify the demonstration that improvements in our knowledge of the effect of beta radiation are important if reliable assessments are to be made. Table 6, which lists the results calculated for wheat, barley, potatoes, and pasture, shows that we could expect in the United Kingdom to lose one-quarter to one-half of our cereal crops and up to one-quarter of our pasture. There would be severe retardation of growth of nearly one-half of the pasture, but potato crops would not be appreciably affected. Table 7 shows the relation between the expected yields of cereals at the next harvest and the requirement to give 2000 Cal per person per day to 25 and 40 million survivors. There is likely to be an overall deficiency of cereals, and this deficiency could be much greater if the beta radiation from fallout increased the effective radiation dose to the crop by a factor of 3 or 4.

Thus we can conclude that, before any reliable estimates can be made based on a regional analysis of the situation and specific attack patterns at particular times, we shall need to have a much clearer idea of the contribution that beta radiation from fallout makes to the total radiation dose received by crops.

CONCLUSION

The very crude assessments made in this paper suggest that, if an attack occurred any time between the early months of the year and the next harvest,

Table 6
RADIATION SENSITIVITY OF CROP PLANTS AND ANTICIPATED LOSS

Crop	Dose (D) resulting in negligible yield*	Dose rate at D + 2 to give D over the period H + 2 to H + 24	Area of country* receiving dose greater than D	Area assuming† beta doubles effective dose	Area assuming‡ beta quadruples effective dose
Wheat	> 1000 R	> 6 R/hr	20%	30%	40%
Barley	> 500 R	> 3 R/hr	30%	40%	55%
Potatoes	> 4000 R	> 20 R/hr	Negligible‡	Negligible‡	20%
Pasture	> 4000 R	> 20 R/hr	Negligible‡	Negligible‡	20%
	> 2000 R growth retarded for 1 month	> 10 R/hr	Negligible‡	20%	40%

*When plant is mature and crop is ripening, there would be little effect on yield.

†Reduction in yield of crop is assumed equal to area of country affected.

‡An area less than 10%.

Table 7
CEREAL YIELDS AT NEXT HARVEST AND REQUIREMENTS OF SURVIVING POPULATION

Crop	Grain yield, million tons			Cereal required to give 2000 Cal/day, million tons	
	No loss	25% loss	50% loss	40 million survivors	25 million survivors
Wheat	3.4	2.6	1.7		
Barley	4.4	3.3	2.2		
Total	7.8	5.9	3.9	8.0	5.0

there would likely be a severe deficiency of calories, mainly because of the inadequate quantities of grain available. Meat, potatoes, and other foods would be unlikely to fill the gap. There would probably be a considerable but not a disastrous reduction in the animal population. The number of survivors could be appreciably increased if the animals could be put under cover, particularly under cover with a protection factor of 2 or 3. Sufficient pasture to support the surviving livestock would probably be available, and it is assumed that the pig population would be greatly reduced to conserve cereals for human consumption. The yield of crops standing in the field would probably be reduced by one-quarter to one-half of that expected, mainly because of radiation damage. It is unlikely that the final crop yield would be sufficient to provide adequate diet for the surviving population.

In all these assessments, for the size of attack envisaged in the model, the beta-radiation component of fallout clearly has an appreciable effect on the numerical results obtained. Although we could carry out a more refined exercise, taking into account actual distributions of livestock and crops and the fallout pattern from specific model attacks, it is doubtful whether much more meaningful assessments could be made until we have a clearer idea of the significance of the beta radiation from fallout. It is clear that, if the results of a nuclear attack were anything like those estimated in this assessment, there would be a chronic shortage of food over a period of at least 2 years. Stocks could be supplemented only by importing food. We must endeavor to refine our knowledge of the beta-radiation contribution to the total damaging effect of fallout since this will influence the importance we must attach to our ability to import foodstuffs. Similar assessments for other countries would indicate their ability to produce surpluses for export to the United Kingdom. We still have some way to go in the United Kingdom before we can make a satisfactory assessment of the medium-term situation that would confront us after a nuclear attack.

REFERENCE

1. M. C. Bell, L. B. Sasser, and J. L. West, Simulated-Fallout-Radiation Effects on Livestock, this volume.

APPENDIX A

REPORTS OF COMMITTEE WORKING GROUPS

Committee 1: Vulnerability of Livestock to Fallout Beta and Gamma Irradiation	627
Committee 2: Vulnerability of Crops to Fallout Beta Irradiation	630
Committee 3: Vulnerability of Crops to Fallout Gamma Irradiation	633
Committee 4: Beta Dosimetry: Calculational Techniques and Measurements	637
Committee 5: Fallout Radiation Fields	639
Committee 6: Radioecological Effects of Fallout Radiation	643
Committee 7: Use and Requirements for Research Data in Agricultural Defense Planning	645

COMMITTEE 1

VULNERABILITY OF LIVESTOCK TO FALLOUT BETA AND GAMMA IRRADIATION

M. C. BELL and E. T. STILL, Cochairmen

J. J. B. Anderson	R. E. Engel	G. D. Potter	L. C. Weldon
R. J. Chertok	D. C. L. Jones	L. B. Sasser	J. L. West
W. T. Cox	S. Z. Mikhail	K. R. Thompson	A. A. Wilson
J. A. Davis	W. F. Nape	D. E. Torkelson	J. H. Wommach
K. E. Diehl			

BETA-RADIATION EFFECTS

Summary of Information Available

Data on the Hereford cows exposed at Alamogordo, New Mexico, July 15, 1945, showed minor to severe lesions from beta irradiation in the fallout deposited on their backs. These lesions occurred at levels for which no lethalties resulted from gamma exposure. Similar observations have been made on animals exposed to fallout radiation at the Nevada Test Site and on Marshallese people exposed to fallout radiation in the Pacific. The immediate effects of beta skin irradiation from actual fallout exposures have not been determined in relation to productivity of farm livestock; however, the effects from simulated fallout on sheep and cattle, discussed at this symposium, show that weight gains are reduced by 30 to 50% in comparison with control animals.

Retention of fallout on plants at levels sufficient to kill the plants has been documented by Rhoads et al. at this symposium. These data and the data on forage retention of fallout particles indicate that ingested fallout could be a problem for grazing livestock. The assumption that ingested fallout would not be a problem has been refuted by the use of insoluble fallout particles, which are much more characteristic of early fallout than the soluble sources previously used. Combinations of beta irradiation with whole-body gamma irradiation affect survival and livestock productivity more severely than any of these irradiations alone. Cattle appear to be more sensitive than sheep to the combined effects, and the implied effects of beta irradiation on milk and meat production are of much greater concern than those of gamma exposure.

Research Information Needed on Beta-Irradiation Effects on Livestock

1. Ingested beta particles.
 - a. Effects of fallout-particle size on lesions of gastrointestinal (GI) tract.
 - b. Threshold level for ingested fallout to affect cattle productivity.
 - c. Rate of passage of fallout simulant in normal cattle and in cattle suffering from GI-radiation exposure.
 - d. GI effects in swine fed fallout simulant.
 - e. Dietary protein, mineral, and energy effects on recovery from GI irradiation. (Note: It has been shown that intestinal disorders may prevent absorption of adequate amounts of essential nutrients.)
 - f. Improved GI dosimetry.
2. Skin beta irradiation.
 - a. Threshold level of skin beta exposure affecting cattle productivity as influenced by season and shelter.
 - b. Effects of ^{90}Y sand placed directly on the backs of cattle in comparison with effects of ^{90}Sr — ^{90}Y flexible sealed sources.
 - c. Effect of the size of the irradiation area on rate of wound healing.
 - d. Dietary protein, mineral, and energy effects on healing rate of beta-irradiated cattle skin.
 - e. Decontamination.
3. Improved fallout simulant. Consideration should be given to choosing a fallout simulant that could be used to expose simultaneously the GI tract, skin, and whole body with a combination of beta and gamma radiation of energy, solubility, and decay characteristics expected for early fallout.
4. Livestock products. Acceptability of meat from animals severely affected by fallout irradiation should be tested.
5. Countermeasure survey.
 - a. Shelter availability.
 - b. Time required to shelter animals.
6. End points or guidelines for livestock producers which indicate what to expect for lethal and sublethal exposures.
 - a. Sheltered livestock.
 - b. Corralled livestock.
 - c. Grazing livestock.
7. Communication and more exchange of information between users, researchers, and damage-assessment workers.

GAMMA-RADIATION EFFECTS

Summary of Information Available

Exposures resulting in lethality to 50% of the gamma-exposed animals in a 30- or 60-day period are reasonably well documented for major livestock

species—sheep, goats, burros, cattle, and swine—when the exposures occur at a high rate over a short time period. Exposure ranges expected to kill all, part, or none of the animals irradiated under these conditions are known. The symptoms expected from gamma radiation at levels that produce lethality in half of the animals exposed are associated with damage to the hematopoietic system, and the blood changes with time are fairly well characterized for most of the species listed, with the exception of cattle.

Less information is available regarding the response of livestock to gamma exposures received over a prolonged time period at much lower exposure rates. In fact, these conditions would more nearly approximate those to be expected from fallout-gamma exposures. There are reported lethality studies in sheep, swine, and goats at exposure rates of the order of a few roentgens per hour to a few roentgens per day. These studies indicate a wide variation in the response to protracted radiation vis-à-vis acute radiation and also in the response among species. It is well known that dose-rate effects are considerable in a number of smaller animals, such as rodents, and this seems to be the case in larger species, especially swine, goats, and sheep. Little is known for burros and cattle exposed at protracted rates.

Some studies have been done in which the recovery patterns were measured following sublethal exposures. Again the species involved were goats, sheep, swine, and burros, and they showed a definite difference in the time required to repair the initial radiation damage.

Throughout the literature there is a paucity of information concerning combined effects of external gamma and beta exposures along with exposures from ingested or inhaled radionuclides. Limited studies have been done with sheep and cattle. Also noted is the lack of studies in which young livestock have been the subject of investigation.

Research Information Needed on Gamma-Radiation Effects

1. Response of the hematological tissue of cattle to total-body irradiation.
2. Response of young and juvenile livestock to total-body irradiation.
3. Recovery patterns of livestock subjected to continuous low-rate exposures.
4. Compilations of data available from studies of the various species to aid in assessing the comparative vulnerability, susceptibility, and probability of recovery for each species.
5. Response of the livestock to the combined effects of beta and gamma exposures in realistic situations.

COMMITTEE 2

VULNERABILITY OF CROPS TO FALLOUT BETA IRRADIATION

R. K. SCHULZ, Chairman

F. P. Hungate
A. I. Lovaas

J. McAulay
L. N. Peters

W. A. Rhoads
E. M. Romney

F. G. Taylor
J. P. Witherspoon

GENERAL CONSIDERATIONS

The radiation contained in fallout following nuclear detonations consists primarily of beta and gamma radiation. The gamma radiation tends to penetrate and expose crops uniformly, but most of the beta-radiation energy is transferred to the first few millimeters of tissue encountered. Since the beta energy is transferred to tissue over a very short path compared with gamma radiation, high beta-to-gamma dose ratios can occur near the surface of plants. Obviously, then, the relative sensitivity of plants to beta vs. the gamma radiation emanating from fallout will be a function of the amount of shielding protecting the more susceptible parts of the plant, i.e., the meristematic tissue. The shielding may consist of air-gap or relatively nonsensitive tissue. Air-gap or distance considerations may well be modified by foliar retention of fallout.

A number of possible consequences may arise from beta-radiation exposure. For instance, beta burns may cause leaf drop; fallout may accumulate in leaf axils and thus inhibit new leaf growth; or contact effects around stems could cause "ringing," which would result in the death of the plant. However, none of these effects have been demonstrated to occur at the relatively low levels that severely affect yield; therefore they need not be especially considered at this time.

Other radiation effects on plants include death, yield reduction, and delayed fruition. In agriculture the yield of foodstuffs is the important product; a live plant without useful yield is of little value, so primary concern should relate to beta effects on yield rather than on survival. The delayed fruition effect can be very important on subsequent yield. If, for example, the maturation of a wheat or barley crop is delayed for a relatively short period because of dry farming

conditions, the yield may well be nil owing to lack of moisture to fill out the grain.

To assess radiation damage to crops, we must take into account both the beta and the gamma component of fallout. When sensitive plant parts are not protected by shielding, as in wheat plants, it is reasonable to expect beta- and gamma-radiation effects to be additive. If, however, the meristematic tissue is well protected by less-sensitive tissue, the effects may be synergistic. For example, the meristematic tissue of a 6-week-old corn plant is well protected by fairly mature leaf tissue, and hence would receive very little beta radiation. The leaves, however, would tend to receive large doses of beta radiation, and this could affect the radiosensitivity to gamma radiation.

It is suggested that, in field experimental investigation of beta-radiation effects on crop plants, the experimental conditions be reported as rads absorbed at the surface of tissue 15 cm above ground surface, as rads absorbed at tissue surface near apical meristem, and, where possible, as microcuries of the isotope or isotopic mixture used in the experiment per square foot of area. The 15-cm level is suggested as a compromise. It is close enough to the soil surface so that, when relatively small experimental plots are used, the edge effect will not be an important problem, and, on the other hand, it is far enough above the soil surface to even out surface-roughness effects somewhat.

RELATIVE PLANT SENSITIVITY

It is felt that initial concern should encompass the major food crops. Of these crops, information available on wheat, corn, potatoes, lettuce, and broad beans was reported in this symposium. From these data and from considerations of plant morphology and gamma data, estimations can be made of likely sensitivity to beta radiation of other important crops. The relative classification estimated here considers plants at their most sensitive stage of development. Management practices (such as flooding of rice, thus protecting meristematic tissue from beta exposure) are taken into account. The following list is intended to provide rough, general guidelines only. Factors such as stage of growth and nature of fallout deposition and retention may radically change crop response.

Probable Relative Sensitivity to Beta Radiation of Some Important Food Crops

Most beta sensitive: Wheat, oats, and barley.

Moderately beta sensitive: Lettuce, soybeans, and many other leafy vegetables in which the meristem is not protected by leaf tissue.

Moderately beta resistant: Corn, sugar cane, sorghum, potatoes, and sugar beets.

Very beta resistant: Rice.

NEEDED RESEARCH

Appropriate research should be carried out to verify and expand this list. The stage of growth at the time of deposition is likely to be of extreme importance and should be thoroughly investigated. Plants will undoubtedly be much more dependent on this factor for beta exposure than for gamma exposure. In addition to the inherent change of plant sensitivity with stage of growth, the amount of ionizing radiation delivered to sensitive plant parts from beta sources is highly dependent on the changing morphology and shielding at the various stages of growth.

Experimental work should be carried out to determine the extent to which beta and gamma radiation interact: Are they simply additive in the apical meristem? In addition, possible synergistic effects should be investigated. For example, little beta radiation will reach the apical meristem of 6-week-old corn plants. However, if the plant is exposed to radiation from a beta-gamma mixture, will the leaves receive high beta doses, and will this reduce the tolerance of the plant to gamma radiation? Other synergistic effects (e.g., resistance to drought, salinity tolerance, frost resistance, delay of plant development and the resulting change of frost tolerance, and possible lack of moisture before crop maturity is attained) which may cause crop failures should be considered. Possible defoliation of forage crops could have some significance.

Existing lists of radiosensitivities of crop-plant species to gamma radiation (Sparrow's lists) should be modified for beta-radiation sensitivity. This could be accomplished by adding information on geometrical factors, such as plant height and tissue depths of sensitive meristematic tissue.

COMMITTEE 3

VULNERABILITY OF CROPS TO FALLOUT GAMMA IRRADIATION *

A. H. SPARROW, Chairman

M. J. CONSTANTIN, Secretary

D. R. Adams

H. Glubrecht

H. F. Lehnert

E. G. Siemer

P. J. Bottino

D. D. Killion

T. D. Rudolph

T. Tanada

C. Broertjes

R. S. Russell

This committee feels that the available data on the effects of fallout-gamma radiation on crops are, in most cases, highly inadequate to fill the needs of the Office of Civil Defense, the U. S. Atomic Energy Commission (USAEC), the U. S. Department of Agriculture (USDA), and the Cooperative Extension Service. Much further research and analyses of existing data are needed. We have attempted to list the most urgent needs and to assign at least preliminary priorities to the various research possibilities. These priorities should not be considered as final or unalterable, however.

A need equally as great as that of more data and better analyses is an immediate effort to improve communications within the research community involved in this area and between this community and the government agencies having the responsibility for radioactive-fallout monitoring, for damage assessment, and for planning possible ways of reducing losses in agriculture, horticulture, and forestry in a postattack environment. Presently there are both serious time lags and some difficulties in interpreting and/or using the research data. Also, a closer working relation between damage-assessment people and researchers in radiobiology is vital to more-efficient use of funds. For instance, yield data, which are expensive to obtain, could in some cases exceed the accuracy required or needed by assessment people. H. F. Lehnert of the USDA Extension Service has agreed to help in the preparation of semitechnical publications that can be widely distributed through extension personnel or other

*Comments of J. Zavitkovski, who did not attend the session, have been added to the preliminary draft.

established channels of communication. However, a better digest of existing data on radiobiological damage to plants and crops is also needed for research workers concerned with the postattack condition of agricultural productivity.

BETA RADIOBIOLOGY

There was essentially unanimous agreement that the greatest weakness in our ability to predict postattack injury to crops is a highly insufficient knowledge of beta-radiation injury and its possible interaction with gamma-radiation injury. The proper appraisal of the total damage anticipated will never be possible until this deficiency is overcome. Our committee concluded that the following specific areas need much further attention.

1. Effects and dose distribution of beta emitters in and around plants, with special reference to differential injury to and within various parts of the plant, especially buds or meristems. Beta sources other than particles are needed for many kinds of beta radiobiological studies. These could be in the form of solid plaques impregnated in soft plastic. If possible, sources should be versatile with respect to kind and amount of emitters incorporated but should be reproducible with respect to dosimetry when this is needed. Electron accelerators could also be used to irradiate plants with doses of accelerated electrons of various energies (these are physically equivalent to beta rays).

2. Deleterious effects of beta radiation alone and with gamma radiation in major crop plants at various stages of development. We believe that, because of the very great differences in distribution of absorbed dose, data from whole-plant gamma or X-ray exposures cannot safely be extrapolated to beta-radiation exposures.

3. Damage assessment of major crops. After some progress has been made in the first two areas, research aimed more specifically at damage assessment can be more intelligently planned and executed.

4. Radiosensitivity of pollen. Such study seems appropriate, especially since all the most important cereal crops and forest trees are wind pollinated. Because of their small size, most pollen grains would be vulnerable to injury from beta radiation both on the plant and in the air. Some pollen is known to be highly radiosensitive, and suitable test systems already exist.

EARLY ASSESSMENT OF ULTIMATE INJURY

There is a great need for more information on early criteria injury to be used for predicting ultimate crop damage.

This is an area not at all well developed, because so far no one has given special attention to it; yet early changes in plant appearance (color, form, exudates, growth rate, wilting, leaf or flower drop, die back, etc.) might give important clues to the ultimate destruction, death, or recovery of irradiated

crops. The development of satellite-borne remote-sensing techniques for detection of early radiation injury should also be given a high priority. A systematic effort to develop our capacity along these lines seems extremely worthwhile and should ultimately be coordinated with early input data on postattack levels of fallout radiation from various geographic areas. It is hoped that ultimately someone in each local area could be well-enough informed to make sensible predictions of probable effects from the data on fallout combined with his own observations of the damaged crops.

FURTHER WORK WITH GAMMA RADIATION

More data on the effects of gamma radiation on crop plants are needed. The following items are most urgent:

1. Influence of variations in exposure, exposure rate, and ratio of beta-to-gamma exposures on crop productivity. This would probably require a portable gamma irradiator and a fallout simulant for the beta component. The upper limits of exposure and exposure rate should be restricted; i.e., they should be a reasonable approximation of the expected upper limits of a predicted fallout situation.

2. Influences of variations in stage of development on radiation injury in various crops. Data are needed on both early and late developmental stages. There is a severe lack of data on late stages (meiotic and postmeiotic through ripe-crop stage), but we know there are rapid changes in sensitivity, probably as great as a factor of 10, at least in some cases. In late stages of seed development or ripening, plants could well suffer serious injury with respect to the next year's crop although injury to the current crop was minor. Geographical variation in stage of development would help to reduce the seriousness of any highly sensitive stage of short duration.

3. End points having the greatest merit for eventual use in damage assessment. More standardization in data collection and more work on the interrelations of end points are also needed.

4. Influences of environmental conditions during and after irradiation and effects of plant competition, which cannot be properly evaluated from present data on pot-culture irradiations. Field experiments are recommended.

5. Data on injury to perennial plants, especially timber- and food-producing (fruit and nut) trees. Available data are mostly limited to survival and are grossly inadequate. No yield data exist for these important crops, and nothing is known about effects on the quality of fruit or timber of surviving trees. The high sensitivity of some of these trees (especially the gymnosperms) is of special concern from the long-term point of view. Also, very little information exists on the capacity of these plants to recover from sublethal damage, and replacement of forests and orchards after severe damage or destruction would be slow indeed. Secondary effects (fire, flood, and loss of nutrients) of radiation damage to forests also could be extensive.

6. Sensitivity of plants or seeds in storage. They are not generally considered serious candidates for severe damage; however, there may be a few crops of unusually high seed sensitivity where special consideration would be appropriate.

7. Wholesomeness and acceptability of crops. In a few known cases, radiation does not destroy the crop in a quantitative sense but in a qualitative sense could affect its usefulness for human consumption, causing, for example, bad flavor or abnormal shape, color, or texture. The nutritional content of the produce from irradiated plants could also be altered.

8. Effects on the ecosystem. Studies are needed to make a balanced assessment. This category is listed last only because it is the special province of another committee of this symposium.

BASIC RADIOBIOLOGICAL RESEARCH ON CROP PLANTS

The basic science of plant radiobiology needs further support to give a better scientific base for understanding, modifying, or predicting fallout damage to economically useful plants. Better science here will mean fewer mistakes and/or omissions of important variables whose significance is not now appreciated. Areas in which our knowledge is especially deficient include the effects of ionizing (beta or gamma) radiation on:

1. The transport system of one or more crop plants.
2. Water loss and uptake and effects on stomata.
3. Ion uptake, transport, and loss.
4. Cell and tissue differentiation.
5. Delayed or reduced flowering or flower initiation.
6. Sexual and asexual reproduction processes and capacity including pollen radiobiology.
7. Seriousness of and recovery from localized beta-radiation injury (including histological and physiological aspects).
8. Possible interaction of localized beta injury, e.g., beta to leaves and gamma radiation to meristems.
9. Photosynthesis.

COMMITTEE 4

BETA DOSIMETRY: CALCULATIONAL TECHNIQUES AND MEASUREMENTS

W. B. LANE, Chairman

Asher Kantz

John Norman

Paul Zigman

This committee discussed the problems of beta dosimetry and the various dosimeters available.

The measurement of beta dose in biological experiments usually requires the ability to approximate a point-dose measurement that, in effect, limits the physical size of the dosimeter. Other desirable properties include a wide range of sensitivities (from a few millirads to kilorads), low energy dependence, reproducibility, and long-term stability.

Thermoluminescent methods seem well adapted to beta-dose measurements. Many different materials having useful thermoluminescent properties have been packaged in a number of ways to provide a variety of dosimeters for specific applications.

Lithium fluoride, calcium fluoride, phosphate glass, and beryllium oxide are among the materials used. Powder, crystals, chips, and other forms of these materials are available. Packaging includes encapsulating in glass, embedding in Teflon, and lighttight wrapping in polyethylene or Mylar.

The precision achieved in dosimetry measurements is usually better than 5% and should in most all cases be better than 10%. The accuracy attained is probably adequate in view of the usual overall experimental error involved in situations in which the dosimeters are used. However, a check of dosimetry-measurement accuracy should be undertaken.

Investigators in the United States who carry out beta-radiation dosimetry will be questioned as to their interest in participating in an experiment to intercalibrate the many different beta dosimeters in current use. Those who express an interest in participating will be requested to submit several dosimeters for evaluation. It was agreed that one possible approach to the intercalibration would be to cast a large volume of ^{90}Y -tagged gelatin and expose the dosimeters to this source. After exposure individual dosimeters would be returned to the

participating investigators for readout. Intercalibration would be accomplished through the results obtained, coupled with efficiency or correction factors applied to the separate dosimeters.

The committee, discussing simulations of fission-product beta radiation, agreed that ^{90}Y was not a bad choice as a simulant considering its half-life, particle energy, availability, and cost. It was accorded, however, that experiments with a low-energy beta-emitting nuclide would be desirable. In considering simulation of total fission-product mixtures, the committee agreed that, rather than to attempt to simulate changing beta energy and decay with time through the use of compounded radionuclide systems, it would probably be preferable to use fission-product mixtures. In this regard, the concept of "fixing" ^{235}U atoms on mineral particles and then exposing the particles to a flux of thermal neutrons should be investigated.

COMMITTEE 5

FALLOUT RADIATION FIELDS

S. L. BROWN, Chairman

Richard Cole
R. C. Dahlman

Richard Hede
A. M. Hekking
Darwin Lapham

C. F. Miller
Yook Ng

The scope of the discussion was limited, in the main, to the properties of fallout-radiation fields that could influence the survival of crops and livestock in the event of nuclear war. Insofar as a qualitative understanding of fallout phenomena and properties is concerned, the state of knowledge within the fallout-research community is probably sufficient for the needs of agricultural-survival research, but in many specific cases quantitative information has not been compiled for easy application by researchers to radiation problems in biology and agriculture. Furthermore, research results need to be translated into relatively straightforward guidelines for operational use by emergency personnel, farmers, and the food industry in case of an attack.

The general features of fallout prediction and distribution and the mechanisms underlying these features are reasonably well understood. Although capabilities for making a detailed, highly reliable prediction of fallout-pattern features and associated radiation fields at any given location do not exist, radiobiology research probably does not require such estimates. In fact, many postattack operational concepts for civil defense depend more heavily on instruments to measure radiation fields than on prediction techniques.

In cases where procedures for estimating fallout are applied to damage assessment, many of the detailed aspects of the process become less important because the estimation of survival depends on more-aggregated properties of the fallout phenomenon through an essentially probabilistic interpretation of the computed radiation fields all across the nation.

Experimental measurements of the effects of radiation on agricultural resources must be related to realistic combinations of various radiation insults, which depend on the properties of the fallout-radiation field. The detailed

aspects of these properties are much better known than are the values of radiation fields for a given location under nuclear war conditions as described previously. The principal radiation insults to be considered include:

1. External gamma radiation.
2. External beta radiation.
 - a. Contact exposure.
 - b. Field (or bath) exposure.
3. Internal beta and gamma radiation.
 - a. Through ingestion.
 - b. Through inhalation.

Among the detailed characteristics of the fallout field which influence the form and severity of these insults are:

1. Energy content and spectra of the radiations.
2. Relative abundance of individual radionuclides.*
3. Physical and chemical properties of particles.
4. Solubility and volatility of incorporated radionuclides.
5. Factors influencing particle retention and uptake, such as the particle size distribution.
6. Factors influencing radiological properties of particles, such as specific activity.†

The most informative starting point is the description of the external gamma-radiation field in terms of an intensity (in roentgens per hour at a given time) and the time of arrival of the fallout. The standard intensity is defined as the exposure rate at 1 hr after fission at 3 ft above the surface computed as if all the fallout had arrived by that time. The total gamma dose accumulated over some specified time period is also often used as a measure of the amount of fallout deposited at a location. Other fallout-field parameters should then be estimated from the standard intensity by the application of appropriate known multipliers or evaluated ratios. Some of the properties so obtained which are significant for agricultural vulnerability studies are:

1. Radionuclide content of the fallout (disintegrations per second, or curies of given radionuclides at given times,‡ per unit area).
2. Mass loading of deposit per unit area.
3. Particle size range likely to be in the fallout deposit.

*If radionuclides are not present in the proportions in which they were produced, the mixture is said to be fractionated. The relative abundances of the radionuclides present influence the overall decay properties of the fields.

†The specific activity or activity density is the radionuclide content per unit mass of inert materials, often expressed in terms of fissions per gram.

‡Note that the abundance of radioactive daughter nuclides does not follow simple exponential decay with time until after the parent has decayed away, and, in fact, the abundance may increase with time over a significant time period.

4. Specific activity of the particles.
5. Solubilities and other physical and chemical properties.

In addition, the beta dose rates and total doses can be expressed for given source and absorber geometries in terms of multipliers on the gamma field.

Although these relations are well understood qualitatively, they are often difficult to quantify; they depend on such variables as the location in the fallout field, the type and location of the detonation, etc., which are not under the control of the investigator. Since no single values for these parameters would apply under all conceivable fallout conditions, a range of values for each multiplier under reasonable conditions may be supplied from available data to use in experiments and assessments.

Future developments in weapon systems are likely to change some of the currently accepted characteristics of fallout fields. For instance, if opponents followed the U. S. trend toward greater numbers of smaller weapons, fallout levels in agricultural areas would probably be smaller than they would be with current weapon capabilities.

The foregoing state-of-the-art assessment is preparation for the following committee recommendations.

In general, the most useful research activity from the viewpoint of the agricultural-survival researcher would be the compilation of presently known characteristics of fallout fields in a form easily interpretable for agricultural-effects work. This might include a tabulation of the most probable sets of properties accompanying various external gamma dose levels, along with known ranges of variation and estimated uncertainties. It would clearly show, however, which sets of assumptions were incompatible with one another.

Although most further detailed fallout phenomenology research would seem irrelevant to current agricultural-vulnerability research, two areas of study should give some needed insights. First, radioiodine appears to be the most important internal radiation hazard in the immediate postattack period. Clarification of the magnitude of this problem in relation to problems from external radiation and of the relative importance of the inhalation and ingestion routes is important. Second, methodologies should be developed for estimating radiation doses from concentrations of fallout particles deposited on or near sensitive biological tissues. The beta contact dose, which applies both to plant meristem damage and to skin or gastrointestinal lesions in animals, is particularly important.

The remainder of the recommendations have to do, not with research per se, but with converting research results into operational guidelines. There is a strong requirement for guidelines to be applied in a postattack setting to determine the most appropriate action on the basis of very limiting data. For instance, a list of critical intensities (measured, say, at 1 day postattack) could be consulted to determine what action to take with regard to a specific agricultural resource. If, for example, the 1-day dose rate in an area exceeded 5 R/hr, it might be best to

assume that all cattle in the area would die. The action to take would then be to slaughter as many as could be processed and abandon the rest. This example shows that operational guidelines should be tied firmly to decision alternatives.

Furthermore, more coordination is needed among agencies responsible for the collection and dissemination of fallout-field information. At present the capabilities of civil defense, agriculture, and transportation in this field are not well integrated.

COMMITTEE 6

RADIOECOLOGICAL EFFECTS OF FALLOUT RADIATION

S. I. AUERBACH, Chairman

H. L. Cromroy	Buford Holt	P. G. Murphy	C. E. Styron
D. DiGregorio	E. W. Lindquist, Jr.	D. E. Reichle	R. I. Van Hook
P. B. Dunaway	Frank McCormick	C. H. Schmidt	George Woodwell
J. F. Gamble		Burke Stannard	

This committee did not consider the details of individual animal response to different modes of radiation insult, since that aspect of civil-defense studies seemed to be more related to the assignments of the other working groups. Instead, we structured our thinking toward the question of how environmental systems would interact in the nuclear war context in terms of essential recovery based on three different time phases: (1) immediate effects and their possible impact on man, (2) longer term impact, and (3) the very-long-term impact.

We reviewed the information on prompt gamma effects on organisms of interest to ecologists, especially higher plants and plant communities. The consensus of the group was that the information provided—mostly by Arnold Sparrow's work on interphase chromosome volume—is satisfactory for predictive purposes. Insofar as future research is concerned, the group believes this area has been well covered, with one possible exception, namely, the lack of data on the effects of gamma radiation on the natural community that is also subject to severe environmental stresses such as drought. This is an aspect of radiation ecology wherein good data are lacking. For example, we are unable to predict the radiosensitivity of a plant community exposed simultaneously to ionizing radiation and to other environmental stresses. How much would the radiosensitivity be enhanced? The committee suggested that it would be enhanced by at least factors of 2 or 3; but good data to substantiate these estimates are lacking.

We strongly concur with the other committees on the need for more information on beta effects. We have very few data on the effects of beta particles on a natural community, particularly when we take into consideration the fact that the plant community will structure the fallout particles in patterns

that differ with community structure. The combination of beta- and gamma-radiation insults to natural communities and their resultant effects cannot be predicted on the basis of present knowledge. From limited information presented at this symposium, it appears that greater land areas could be subjected to larger doses than heretofore anticipated. Furthermore, organisms, both on the ground and near the ground, would be subjected to greater dose than has been anticipated. This focused our thinking on a major question, that of total ecosystem response to radiation fallout. By total ecosystem response, we mean not only the primary effects of the radiation, i.e., on forests or grassland systems, but also the subsequent secondary responses of the organisms in the system to the radiation. If the ecosystem is broadened in concept to include an increasingly greater geographical area that would encompass areas including food and water resources, our predictive knowledge becomes increasingly meager. How is the system subsequently degraded as a result of these combined insults? How would degradation of the ecosystem affect the long-term distribution of radionuclides to the surviving populations by way of the terrestrial and aquatic food chains?

The committee recommends that field experiments be done in which combined beta and gamma sources are applied to natural systems to obtain data on primary, secondary, and long-term response of the ecosystem to the insult.

Over the very long term, broad questions of concern to all ecologists still remain. Man is changing his support systems, perhaps moving them from one level of stability to another. The long-term indications are that each level of stability is slightly degraded compared to the previous level. In the context of this symposium, the unanswered question is whether nuclear war would enhance man's degrading of a number of his major support systems and if so, to what extent. This is a broad question, and it can be answered only in the context of a much broader research program in ecology.

COMMITTEE 7

USE AND REQUIREMENTS FOR RESEARCH DATA IN AGRICULTURAL DEFENSE PLANNING

G. H. WALTER, Chairman

A. K. Burdett, Jr.	S. A. Griffin	W. T. L. Neal	M. J. Stangler
B. M. Easton	N. S. Hall	P. F. Sand	W. E. Strobe
H. A. Gaut	William Kittel	E. C. Sharmon	E. G. Warner
J. C. Greene	U. B. Mistry	R. E. Simpson	

After considerable discussion the committee agreed that:

1. Future research should concentrate on the effects of reasonable combinations of fallout beta and gamma irradiation using realistic fallout decay rates on growing crops of wheat, corn, soybeans, alfalfa, and grain sorghums, and on cattle, hogs, and chickens. The U. S. Department of Agriculture (USDA) interest is in levels of fallout that noticeably affect productivity of these crops and livestock and in determining lethal levels. Except for iodine, the concern is primarily with the radiation occurring in the first few days after an attack.

2. Research relative to ingestion of fallout by humans should concentrate on the radioactive iodine problem and should cover means of evaluating it and of eliminating or protecting against radioiodine. This is largely a problem in milk. Other studies should include effects on livestock of ingesting gross fission products incorporated in a realistic fallout simulant.

3. Further guidance is needed on the salvage of irradiated livestock, both in terms of how to do it and in terms of usability criteria. Policy decisions are needed on how much and how to relax present standards after a nuclear attack.

There was a spirited discussion of the standards that should be used postattack in salvage of livestock for meat. For example, USDA inspection standards will not permit use of meat from animals showing fever from radiation or any other cause. On the other hand, there is no indication of harm to humans eating meat from animals with radiation sickness. The danger is that the cause of the animal's illness cannot be easily determined.

The acceptability of a policy of eating any food not too "gritty" to be acceptable was raised. Although there was agreement that, in a post-nuclear-attack environment, a gritty taste might indicate the presence of radioactivity,

the absence of grit would not necessarily indicate that radioactivity was not present. This would be true especially of soluble nuclides such as radioiodine. It was agreed that guidelines for use of foods containing fallout radioactivity, such as ^{90}Sr and ^{131}I , should be developed for possible application in a postattack period. No conclusions were reached on whether research was needed to develop new equipment for measuring fallout in food or whether existing field and laboratory instrumentation would suffice.

The committee did not feel that further research on ways of decontaminating land or buildings rated a high priority for further research. For the most part, the feeling was that the rapid decay of fallout radioactivity would eliminate most of the hazard by the time it was feasible to resume farming operations.

The difficulties of combined beta-gamma research under conditions similar to those to be expected from nuclear war fallout were recognized, but the group felt that such research is needed. Field research along these lines would be practical and is necessary to provide guidance for USDA defense planning. In view of the practical problems involved, it might be desirable to concentrate such research at one or two locations. Also, in future research the radiation dose rates used should be those of levels to be expected outside the blast destruction area. If plants and animals will be killed by blast or fire, the fact that they are also exposed to lethal radiation doses is unimportant.

The chairman raised the question of the need for radiation research on forest trees. It was agreed that the results of the gamma forest experiment at Brookhaven National Laboratory are not representative nor indicative of what would be expected from combined beta-gamma radiation on commercial timber stands. The primary use of forestry radiation studies would be in connection with fire fighting. It was decided that such radiation forestry research was of relatively low priority but that any future research aimed at nuclear defense planning should concentrate on commercial-type forest stands and should include combined beta-gamma effects of fallout.

To assist the nonresearch people in use of research data, the chairman suggested that a "glossary of terms" should be developed and used for all nuclear research. Research people should refrain from development or use of unusual terminology. Some group such as the Radiation Research Society might well develop such a glossary as a service to all involved.

APPENDIX B

RADIATION EFFECTS ON FARM ANIMALS AND CROPS

Vulnerability of Livestock to Fallout Gamma Radiation	648
<i>Edwin T. Still and Norbert P. Page</i>	
Radiation Effects on Farm Animals: A Review	656
<i>M. C. Bell</i>	
The Effects of External Gamma Radiation from Radioactive Fallout on Plants, with Special Reference to Crop Production	670
<i>A. H. Sparrow, Susan S. Schwemmer, and P. J. Bottino</i>	

VULNERABILITY OF LIVESTOCK TO FALLOUT GAMMA RADIATION

EDWIN T. STILL* and NORBERT P. PAGE†

*U. S. Atomic Energy Commission, Division of Biology and Medicine, Washington, D. C.,
and †National Cancer Institute, Bethesda, Maryland

ABSTRACT

In the event of a nuclear war, a valuable resource, i.e., the nation's livestock, will probably be subjected to gamma radiation from fallout. As background for the working session on vulnerability of livestock to fallout gamma irradiation, the LD_{50} , recovery patterns, and causes of death for common livestock are briefly reviewed. Additionally, other studies are suggested as necessary to complete the information required for assessing the probable effect of nuclear war on livestock.

The cattle, swine, sheep, goats, and other livestock of the nation constitute a valuable resource in terms of food supply and of economic value. In the event of a nuclear war, livestock populations would no doubt be exposed to residual fallout gamma radiation. Because of our heavy dependence on livestock for nutrients and for conversion of undesirable foodstuffs into nutrients, reliable vulnerability estimates for the effects of fallout on the survival and production capabilities of these animals are certainly worthwhile.

It is fair to say that, for the greater part of each year, livestock are not housed. They are on pasture, somewhat removed from urban, heavily populated areas. In the event of nuclear war, many urban areas might be subjected to airbursts, and the animals near these areas would receive damage primarily from blast and thermal effects. However, there are large numbers of hard targets that might be subjected to surface bursts resulting in great quantities of radioactive fallout over areas with heavy livestock populations. This fallout would cause the major part of the gamma exposure of concern to the livestock industry.

In this regard then, a number of parameters must be considered in assessing the impact of such a situation on the livestock resources of the nation. We must know the effect of different exposure geometries, the dose to critical organs, the

lethal dose for various species, the effect of various exposure rates on probable lethality, the effect of less-than-lethal exposures, and the recovery pattern for various species exposed to less-than-lethal doses. Knowing these factors will enable the formulation of suitable plans to provide the maximum protective efforts available to ensure the survival and continued production of the livestock resources.

Although no method of expressing the radiation dose is entirely adequate to predict the degree of effect for large animals differing greatly in size, the dose measured at the midline of the animal's body seems to provide the most meaningful physical dose measurement to correlate with the biological response for uniform or bilateral exposures to low linear energy transfer (LET) radiations.¹ With bilateral or omnidirectional exposures to low-LET radiation, the dose-distribution is relatively uniform throughout the body, the midline-tissue dose being roughly representative of the dose received at any single point. It is probably correct to assume that exposures of livestock on the open range to fallout gamma radiation would, in the main, be omnidirectional. However, the observed midline-tissue dose is not the same as the midline-air dose for the larger animals such as livestock. The observed ratio of midline-tissue dose to a midline-air dose is highly dependent on the size of the animal. The following are representative values reported for some larger animals irradiated with ⁶⁰Co or X rays (250 to 1000 kVp): 0.060 to 0.68 for swine,²⁻⁴ 0.58 to 0.63 for sheep,^{5,6} and 0.40 to 0.50 for cattle and burros.^{7,8}

Bond and Robinson¹ concluded that for uniform exposures the midline-tissue dose was satisfactory for "normalizing" the effective dose of exposures for animals of various sizes. Since we have assumed that uniform exposures would occur from gamma radiation resulting from fallout, the midline-tissue dose is used here for such a normalizing purpose for the lethality studies reported.

Lethality studies pertaining to whole-body irradiation of large animals can be grouped into two categories depending on the time and intensity of the exposures: (1) the median lethal dose (LD₅₀) estimates determined by continuous terminated exposures, and (2) studies in which animals were irradiated until death either by a continuous low-dose-rate exposure or by daily fractionated exposures. These are summarized in Tables 1 to 3.

Several points are immediately apparent from the data in these tables. First, the median lethal doses fall in a rather narrow range for the terminated exposures, ranging from 125 to 425 rads at the mid-tissue dose. Second, there is a much larger range in the LD₅₀ values if the midline-air dose in roentgens is used. Third, in general, all the dose rates are reasonably high, i.e., of the order of several roentgens per hour. It is also quite apparent that the radiation given at higher dose rates is more effective in producing lethality than that at lower dose rates. In other words, the lower the dose rate, the higher is the LD₅₀. With the exception of the sheep and swine studies at the Naval Radiological Defense Laboratory and some goat studies at Texas A & M University, there are no real low-dose-rate studies (less than 0.1 R/min) in large animals.

Table 1
 MEDIAN LETHAL DOSE (LD₅₀) VALUES FOR LARGE ANIMALS
 EXPOSED TO GAMMA OR X IRRADIATION*

Radiation source	Dose rate, R/min	Method of exposure	Median lethal dose (LD ₅₀)		Reference
			Midair dose, R	Mid-tissue dose, rads	
Burros					
1000-kVp X ray	7.5	Bilateral	369	155	8
⁶⁰ Co	0.85	Multisource	784	280	13
¹⁸² Ta	0.37	Multisource	641	290†	14
⁹⁵ Zr- ⁹⁵ Nb	0.28	Multisource	385	350†	15
Cattle					
⁶⁰ Co	6.6	Multisource	200	125‡	16
⁶⁰ Co	0.9	Multisource	450	150	7
⁶⁰ Co	0.9	Multisource	543	160	7
Goats					
2500-keV gamma	32.5	Bilateral	395	240‡	17
1000-kVp X ray	7.5	Bilateral	312	200	12
⁶⁰ Co	1.3	Bilateral	550	350‡	18
Sheep					
⁶⁰ Co	11.0	Bilateral	237	145	5
1000-kVp X ray	7.5	Bilateral	252	146	5
1000-kVp X ray	7.5	Bilateral	314	189	11
250-kVp X ray	7.5	Bilateral	389	245	6
⁶⁰ Co	4.35	Bilateral	318	194	9
⁶⁰ Co	0.5	Bilateral	338	206	9
⁶⁰ Co	0.3	Multisource	524	205§	19
⁶⁰ Co	0.06	Free moving¶	495	302	9
⁶⁰ Co	0.033	Free moving¶	637	389	9
Swine					
⁶⁰ Co	50.0	Bilateral	350 to 400	240	2
1000-kVp X ray	30.0	Bilateral	510	250**	4
⁶⁰ Co	18 to 29	4 pi	393	228	20
⁶⁰ Co	18 to 29	4 pi	335	218	20
1000-kVp X ray	27.0	Bilateral	425	255	21
2000-kVp X ray	15.0	Bilateral	350 to 400	230**	4
⁶⁰ Co	11.5	Bilateral	375	260	22
⁶⁰ Co	10.0	Bilateral	400 to 450	270	2
1000-kVp X ray	9 to 10	Bilateral	399	270	3
⁶⁰ Co	1.0	Bilateral	650 to 700	425	2
⁶⁰ Co	0.85	Multisource	618	370**	13
⁶⁰ Co	0.067	Free moving¶	2000 to 2500	1350 to 1700	10

*Only studies in which a relatively homogeneous depth-dose distributions were obtained are presented in this table. Those in which unilateral or dorsal-ventral exposures or low-energy radiations were utilized are not included.

† Value is estimated by Trum.^{1,5}

‡ Estimate is based on data presented in the reference cited.

§ Value is estimated by Bond.¹

¶ Although they were exposed from one direction, the animals' random-movement resulted in equal exposure to both sides, providing an effective bilateral exposure.

** Value is estimated by D. Brown.²

Table 2
SURVIVAL OF SHEEP AND GOATS EXPOSED
CONTINUOUSLY TO ^{60}Co RADIATION

Species	Dose per day and dose rate	Mean survival time, days	Mean cumulative lethal dose, R
Sheep ^{2,3}	46 R at 0.033 R/min	43 (males)	1975
Goat ^{2,4}	40 R at 0.033 R/min	57 (males)	2280
		50 (females)	2000
	30 R at 0.025 R/min	85 (males)	2550
		81 (females)	2430
	15 R at 0.013 R/min	240 (males)	3600
	161 (females)	2415	
	7.2 R at 0.007 R/min	1152 (males)	8330
		384 (females)	2650

Table 3
SURVIVAL OF LARGE ANIMALS EXPOSED TO FRACTIONATED
DAILY EXPOSURES OF ^{60}Co RADIATION*

Species	Dose per day and dose rate†	Mean survival time, days	Mean cumulative lethal dose, R
Burro	Single dose	25	
	400 R at 0.28 R/min	8	3,320
	200 R at 0.14 R/min	14	2,820
	100 R at 0.07 R/min	23	2,330
	50 R at 0.035 R/min	30	1,510
	25 R at 0.017 R/min	63	1,575
Cattle	Single dose	20	
	100 R at 0.07 R/min	32	3,200
	50 R at 0.035 R/min	45	2,250
Swine	Single dose	15	
	100 R at 0.07 R/min	39	3,900
	50 R at 0.035 R/min	205	10,250

*These studies were conducted at the UT-AEC Agricultural Research Laboratory; the multiple-source (^{60}Co) exposure at a dose rate of 0.5 to 0.85 R/min was used (Brown²).

†Dose rate in roentgens per minute calculated as though the daily exposure was continuous for the entire 24 hr per day.

The data in Table 2 for goats and sheep exposed continuously until death at rates of a few roentgens per hour dramatically show the relation of dose rate to lethality, as do the fractionated data of Table 3. The total data are consistent with the generally accepted conclusion that effectiveness of the dose is diminished as the dose rate is diminished or as the period of exposure is protracted. However, it is clear that the relation between dose rate and LD_{50} is not linear, especially at the lower dose rates. This was discussed by Page⁹ in another paper, from which most of the data for these tables were taken.

There must be a mechanism to explain the loss of effectiveness with decreasing dose rate or protraction of radiation exposures. Recovery from part of the exposure during the continued exposure is probably the explanation. A number of recovery studies^{3,5,8,10-12} have been done with large domestic animals. The recovery rates of the various species can be estimated from these studies; the species, ranked in descending order of recovery, are swine (fastest), goats, sheep, and burros. These studies used the "split-dose" or "paired-dose" technique to determine the recovery; this technique consists essentially in determining the change in LD_{50} with time after a sublethal conditioning radiation exposure.

The data show that the recovery for large animals may vary from the very slow early recovery seen in sheep, goats, and burros to the rapid early recovery seen in swine. A resistance or overrecovery occurs in sheep and swine, with the resistance of swine appearing to be rather long lasting, at least to 100 days. Swine appear to be unique in this long-lasting resistance. Goats recover to a normal state but, unlike sheep, do not show a period of overresistance. For burros it appears that there is no overrecovery and that the recovery process is very slow indeed. If subjected to close analysis, the data show that recovery is somewhat dependent on the size of the initial conditioning exposure or initial injury. Although most recovery studies used two-thirds of the LD_{50} as a conditioning dose, one study^{2,3} with sheep used a conditioning dose of one-third of the LD_{50} . This study indicated the strong influence of the size of the initial radiation injury on subsequent recovery: the pattern of the recovery curve was similar for sheep conditioned with either one-third or two-thirds of the LD_{50} exposure, but, quantitatively, recovery occurred at a more rapid rate, and overrecovery was greater for animals conditioned with a smaller exposure.

The cause of death for most of the animals exposed at rates that may reasonably be expected from fallout gamma radiation appeared to be hematopoietic damage. Usually there was an early and a rapid drop in the mononuclear white cells followed by a severe drop in blood platelets. If the dose was less than lethal, the blood elements showed a return toward normal with time, i.e., recovery. However, if the exposure continued or if the initial exposure was of sufficient magnitude, the blood elements continued to decrease and death occurred.

An exception to this case is the burro. In burros a number of early deaths were noted; these were associated with a central nervous system (CNS) type of

syndrome. Apparently this CNS syndrome at relatively low total doses is unique to the burro, although we know of at least one adult cow that died within 2 hr after an exposure of less than 500 R of ^{60}Co . This was a leukemic animal in poor condition initially, however, and, since she was not observed during the period, her movements were not recorded.

In general, what is known regarding the vulnerability of livestock to gamma radiation can be summarized as follows:

The midline-tissue doses would be of the order of one-half to two-thirds of the midline-air exposures and would probably be omnidirectional. Radiation doses causing lethality would be of the order of 125 to 300 rads, but the rate at which the exposure is received would have a great bearing on the effect. In general, the lower the rate of delivery, the greater is the lethal dose. However, the few studies in which animals have been continually exposed until death at low rates show that, at about 20 to 40 R/day, a steady state cannot be maintained. Median survival times are prolonged, up to 40 to 80 days, but death ensues. The goats exposed by Hupp²⁴ to about 7 R/day had median survival times of 384 days for females and 1152 for males; this shows a great difference due to sex.

All the studies indicate that recovery will occur when the initial exposure is less than lethal or when the dose rate is sufficiently low. Again, however, there is a great difference in the recovery times for the various species, as well as in the patterns of recovery.

It is worthwhile to note that, in all the studies reported, the experimental subjects were usually young adult or mature animals. The response of younger animals to radiation would be of interest: Would it be about the same as for the adults? Would the recovery patterns be similar? Would the young have more or less tolerance? There are few studies involving cattle, especially regarding median lethal doses, and horses. Whether it is valid to extrapolate from sheep and goat or burro data should be resolved.

A very important aspect for civil-defense consideration is the development of a simplified set of descriptive symptomatology that the lay person (i.e., the owner or herdsman) can use in the field. The response of livestock to gamma radiation is reasonably characterized under laboratory conditions, especially for exposures at the higher rates and, to some extent, for exposures at protracted rates. The experienced individual can easily detect small changes in the condition of an exposed animal when various laboratory and diagnostic procedures are available to him. But these procedures are not a "tool" in the average farmer's inventory. What is needed is a straightforward guideline that will tell the farmer what procedures he should follow if he recognizes certain signs exhibited by exposed animals and what the likely outcome will be for the animals that show these changes. Such a guideline would be of considerable value in helping the farmer plan his future actions.

REFERENCES

1. V. P. Bond and C. V. Robinson, A Mortality Determinant in Nonuniform Exposures of the Mammal, *Radiat. Res., Suppl.*, **7**: 265 (1967).
2. D. G. Brown and R. Cragle (Eds.), Proceedings of a Symposium on Dose Rate in Mammalian Radiation Biology, Apr. 29–May 1, 1968, USAEC Report CONF-680410, UT–AEC Agricultural Research Laboratory, July 12, 1968.
3. D. S. Nachtwey, E. J. Ainsworth, and G. F. Leong, Recovery from Radiation Injury in Swine as Evaluated by the Split-Dose Technique, *Radiat. Res.*, **31**: 353–367 (1967).
4. J. L. Tullis, F. W. Chambers, J. E. Morgan, and J. H. Zeller, Mortality in Swine and Dose Distribution Studies in Phantoms Exposed to Supervoltage Roentgen Radiation, *Amer. J. Roentgenol., Radium Ther., Nucl. Med.*, **67**: 620 (1952).
5. G. E. Hanks, N. P. Page, E. J. Ainsworth, G. F. Leong, C. K. Menkes, and E. L. Alpen, Acute Mortality and Recovery Studies in Sheep Irradiated with ^{60}Co Gamma Rays or 1-Mvp X Rays, *Radiat. Res.*, **27**: 397–405 (1966).
6. T. S. Mobley, W. R. Godden, and J. deBoer, Median Lethal Dose ($\text{LD}_{50/60}$) Studies in Sheep Following 250 kvp X Irradiation, Report AD-631189, Air Force Weapons Laboratory, Kirtland AFB, N. Mex., March 1966 (AFWL-TR-65-200).
7. D. G. Brown, R. E. Thomas, L. P. Jones, F. H. Cross, and D. P. Sasmore, Lethal Dose Studies with Cattle Exposed to Whole-Body Co^{60} Gamma Radiation, *Radiat. Res.*, **15**: 675–683 (1961).
8. E. T. Still, N. P. Page, J. F. Taylor, W. G. Wisecup, E. J. Ainsworth, and G. F. Leong, Acute Mortality and Recovery Studies in Burros Irradiated with 1-Mvp X Rays, *Radiat. Res.*, **39**: 580–593 (1969).
9. N. P. Page, Effect of Dose Protraction on Radiation Lethality of Large Animals, in Proceedings of a Symposium on Dose Rate in Mammalian Radiation Biology, Apr. 29–May 1, 1968, D. G. Brown and R. Cragle (Eds.), USAEC Report CONF-680410, pp. 12.1–12.23, UT–AEC Agricultural Research Laboratory, July 12, 1968.
10. J. F. Taylor, N. P. Page, E. T. Still, G. F. Leong, and E. J. Ainsworth, The Effect of Exposure Rate on Radiation Lethality in Swine, Report USNRDL-TR-69-96, Naval Radiological Defense Laboratory, 1969.
11. E. T. Still, J. F. Taylor, G. F. Leong, and E. J. Ainsworth, Mortality of Sheep Subjected to Acute and Subsequent Protracted Irradiation, Report USNRDL-TR-69-32, Naval Radiological Defense Laboratory, 1969.
12. J. F. Taylor, E. T. Still, N. P. Page, G. F. Leong, and E. J. Ainsworth, Acute Lethality and Recovery of Goats After 1-Mvp X irradiation, *Radiat. Res.*, **45**: 110–126 (1971).
13. J. H. Rust, B. F. Trum, J. L. Wilding, C. S. Simons, and C. L. Comar, Lethal Dose Studies with Burros and Swine Exposed to Whole-Body Cobalt-60 Irradiation, *Radiology*, **62**: 569–574 (1954).
14. J. H. Rust, J. L. Wilding, B. F. Trum, C. S. Simons, A. W. Kimball, Jr., and C. L. Comar, The Lethal Dose of Whole-Body Tantalum 182 Gamma Irradiation for the Burro (*Equus asinus*), *Radiology*, **60**: 579–582 (1953).
15. B. F. Trum, J. J. Lane, U. S. G. Kuhn III, and J. H. Rust, The Mortality Response of the Burro (*Equus asinus*) to a Single Total-Body Exposure of Gamma Radiations from $\text{Zr}^{95}/\text{Nb}^{95}$, *Radiat. Res.*, **11**: 314–325 (1959).
16. M. O. Schultze, V. Perman, N. S. Mizuno, F. W. Bates, J. H. Sautter, H. S. Isbin, and M. K. Loken, Effects of Gamma Radiation on Calves, *Radiat. Res.*, **11**: 399–408 (1959).
17. P. W. Edmondson and A. L. Batchelor, Clinical and Pathological Response of Goats to Whole-Body Irradiation by Gamma-Rays and Fission Neutrons, *Int. J. Radiat. Biol.*, **10**: 451–478 (1966); also Eye Findings in Goats During the 3 Years After Acute Whole-Body Neutron and Gamma Irradiation, *Int. J. Radiat. Biol.*, **13**: 147–153 (1967).

18. G. M. Krise, J. W. Austin, and E. W. Hupp, Lethal Effects of Acute and Continuous Radiation in Goats, *Radiat. Res.*, **35**: 532 (1968).
19. B. F. Trum, in Agricultural Research Program. Semiannual Progress Report for Jan. 1, 1955, to June 30, 1955, USAEC Report ORO-145, University of Tennessee, November 1955.
20. F. W. Chambers, Jr., C. R. Biles, L. J. Bodenlos, and J. H. Dowling, Mortality and Clinical Signs in Swine Exposed to Total-Body Cobalt-60 Gamma Irradiation, *Radiat. Res.*, **22**: 316-333 (1964).
21. V. P. Bond, in Operation GREENHOUSE. Scientific Director's Report, Annex 2.2. Control Studies Performed in the United States and at Eniwetok, Parts I, II, IV, and VI, USAEC Report WT-18, 1951.
22. N. P. Page, D. S. Nachtwey, G. F. Leong, E. J. Ainsworth, and E. L. Alpen, Recovery from Radiation Injury in Sheep, Swine, and Dogs as Evaluated by the Split-Dose Technique, *Radiat. Res.*, **25**: 224 (1965).
23. E. T. Still, J. F. Taylor, G. F. Leong, and E. J. Ainsworth, Survival Time and Hematological Responses in Sheep Subjected to Continuous ^{60}Co Cobalt Gamma Irradiation, Report NRDL-TR-69, 1969.
24. E. W. Hupp, Texas Woman's University, Denton, Tex., personal communication, 1970.

RADIATION EFFECTS ON FARM ANIMALS: A REVIEW

M. C. BELL

UT-AEC Agricultural Research Laboratory, Oak Ridge, Tennessee

ABSTRACT

Hematopoietic death would predominate in food-producing animals exposed to gamma radiation under fallout conditions leaving animal survivors. Gamma-radiation doses of about 900 R would be lethal to 50% of poultry, and about half this level would be lethal for cattle, sheep, and swine. Grazing cattle and sheep would suffer most from combined radiation effects of skin-beta and ingested-beta radioactivity plus the whole-body gamma effects. The $LD_{50/60}$ for combined effects in ruminants is estimated to be at a gamma exposure of around 200 R in an area where the forage retention is 7 to 9%.

Either external parasites or severe heat loss could be a problem in skin irradiated animals. Contrary to early reports, bacterial invasion of irradiated food-producing animals does not appear to be a major problem. Productivity of survivors of gamma radiation alone would not be affected, but, in an area of some lethality, the productivity of surviving grazing livestock would be severely reduced owing to anorexia and diarrhea. Sheltering animals and using stored feed as countermeasures during the first few days of livestock exposure provide much greater protection than shielding alone.

The purpose of this review is to summarize the data available on the effects of ionizing radiation on food-producing animals which would be of value in predicting the effects that could be encountered from radioactive fallout in the event of nuclear war. Most of the data are limited to somatic effects of gamma and beta radiation on survival and productivity of cattle, swine, and sheep. Although much more information is available on radiation effects in small laboratory animals, it is difficult to extrapolate these data to large food-producing animals exposed to a combination of internally and externally applied radiation. Some attention is also given to measures that could be used to reduce radiation exposure of food-producing animals.

Ionizing radiation from radioactive fallout occurs principally as beta particles and gamma rays. The median beta energies are between 0.3 and 0.4 MeV, but the maximum may be up to 5 MeV. Most of the data available on beta

irradiation effects on food-producing animals were obtained by using either ^{90}Y or ^{90}Sr - ^{90}Y , which have higher average energies than are characteristic of local fallout. Information on gamma irradiation was obtained principally by exposing large animals to ^{60}Co or ^{137}Cs , which have penetration characteristics similar to gamma fallout radiation.

Limited information is given on neutron exposures, and none is given on alpha radiation since neither of these emissions is expected to be of any consequence in radioactive-fallout effects on food-producing animals.

RADIATION LETHALITY

General

Exposures to gamma radiation at dose rates expected under fallout conditions causing early deaths in about half of the animals are expressed as a dose lethal to 50% in either 30 or 60 days ($\text{LD}_{50/30}$ or $\text{LD}_{50/60}$). This mortality level varies with dose rate, quality and type of radiation, animal species, and a number of other variables. The upper and lower limits of the distribution of radiation deaths for adult cattle, swine, and burros are shown by the typical sigmoid curves in Fig. 1. The data obtained from ^{60}Co exposure to

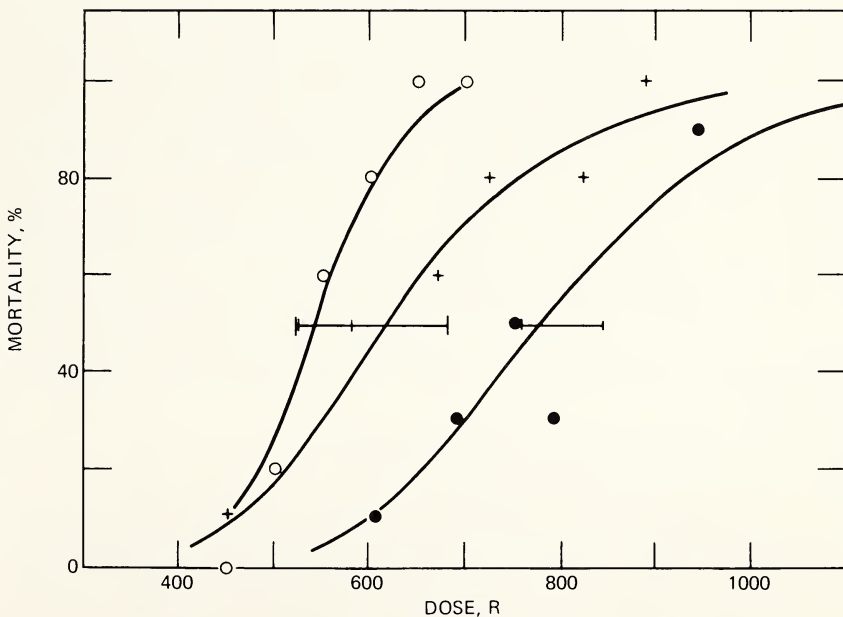

Fig. 1 Mortality of three species exposed to ^{60}Co at a dose rate between 0.5 and 1 R/min. ○, cattle; +, swine; ●, burros; —, 95% confidence interval. (Data from D. G. Brown, UT-AEC Agricultural Research Laboratory.)

dose rates of 0.5 to 1 R/min show the species variation among these large animals. This variation is much greater at the 99% mortality level than for 1% mortality.

The gamma-radiation dose levels are usually expressed as either midline "air dose" or midline absorbed dose as discussed by Page.¹ Because of tissue mass, the gamma-radiation midline dose from fallout would be reduced by at least 50% in adult cattle, but for poultry the reduction would be inconsequential. In this review the gamma-radiation exposures are listed as the air dose to the animals, and the units are in roentgens. The data most applicable for gamma radiation from fallout in which there would be at least 20% survival of continuously exposed animals would be in fallout-deposition areas where the dose rate would not be expected to exceed 2 R/min for a period of over 1 hr. An exception to this rule would be animals that might be moved from a heavily contaminated field into a protective shelter until the early fallout had decayed to a nonlethal level. A review by Page¹ showed that dose-rate effects are considerable in swine and very slight in sheep and burros. Sheep were more sensitive than swine at all dose rates reported. Reduction of the dose rate from 2 R/min to 0.1 R/min increased the estimated LD₅₀ dose to sheep by 20% and to swine by 340%. Swine also show 50% recovery in 3 days from acute gamma-radiation exposure, whereas sheep require about 13 days.² In a review article Brown and Cragle³ reported that the swine LD_{50/30} at 0.85 R/min was 618 R but at 18 to 29 R/min only 310 R. They also reported that young cattle are more sensitive to gamma irradiation than adult cattle. In general, it is assumed that the young are more sensitive to radiation; however, Case and Simon⁴ reported that at a dose rate of 4 R/min the LD_{50/30} for newborn pigs was 375 R, which is near the estimated LD_{50/30} for older swine. Data for predicting dose-rate effects in cattle are very limited, but, in general, the higher the dose rate, the lower the LD_{50/30} is in the species studied (Fig. 1). Fallout dose rate varies with weapon yield, type of burst, distance downwind, wind speed, and number and frequency of detonations. Considering both fallout and animal species variables, it appears that the most useful data would be those obtained on animals continuously exposed to early fallout, but no such data were found; therefore only information on animals exposed to a gamma dose rate of from 0.1 to 2 R/min is considered.

Symptoms of Gamma-Fallout-Radiation Sickness

The primary symptoms expected from gamma radiation alone at levels to produce some deaths in farm animals are those associated with damage to the hematopoietic system. These usually include a severe drop in blood platelets to the point that blood would be lost into intracellular spaces and from both the respiratory and gastrointestinal (GI) tracts owing to failure in blood clotting. Increased capillary permeability also contributes to loss of blood cells, plasma, and electrolytes. Most of these losses occur between 14 and 30 days after

exposure when there are also low white-cell counts, sometimes accompanied by pyrexia and bacterial invasion.⁵ Cattle exposed to 200 to 600 R at dose rates of 0.5 to 1 R/min usually show mild anorexia and slight pyrexia for about 24 hr; they then appear normal until about 14 days, when there is a marked pyrexia in those lethally irradiated; the survivors show a mild pyrexia.

Anorexia and vomiting, which may be associated with the gastrointestinal death syndrome, would be expected in few if any of those surviving gamma irradiation. At the exposure and dose rate considered, the central nervous system (CNS) may be affected in some burros.³ Data on burros are included since meat of equine origin is consumed at the annual rate of 2 to 3 kg per person in some European countries. The CNS and gastrointestinal death syndromes in gamma-irradiated animals would be expected only if the dose rate were higher than 2 R/min. Vomiting, anorexia, and weight loss were reported in swine exposed to 250 to 700 R of ^{60}Co gamma radiation at 21 R/min giving an approximate $\text{LD}_{50/30}$ of 335 R for 33-kg swine.⁶ None of these symptoms were seen in 30-kg growing swine surviving an exposure to 450 R at 0.6 R/min from a multisource ^{60}Co field.⁷ Pigs that died showed anorexia and blood loss for only 2 days prior to death, which occurred 16 to 20 days after exposure. Case and Simon⁴ observed a mild transitory diarrhea in newborn pigs exposed to ^{60}Co and found an $\text{LD}_{50/30}$ of 375 R at 4 R/min. These pigs had diarrhea at 2 to 5 days after irradiation and cutaneous hemorrhages at 9 to 14 days; all deaths occurred between 10 and 29 days postirradiation. Therefore it appears to be very important to consider the dose rate in determining the symptoms and $\text{LD}_{50/30}$ in swine exposed to gamma radiation. These data would probably also apply to other species of food-producing animals, but available data are insufficient for definite conclusions.

Beta-Radiation Effects

Predictions by the National Academy of Sciences—National Research Council (NAS—NRC) committee,⁸ based primarily on data gained from dosimeter readings in dogs and goats fed sublethal levels of $^{90}\text{YCl}_2$ solution,⁹ were that the large intestine would be the critical organ and that fallout ingested by grazing livestock would be of little consequence compared with gamma-radiation effects. These conclusions were based on the assumption that fallout would be homogeneously mixed with the contents of the GI tract.

Although no research data are cited, a 1965 USSR textbook¹⁰ entitled *Civil Defense in Rural Regions* states that inflammation of the mucosa of lips, gums, and the deep part of the oral cavity occurs in livestock consuming contaminated feed and water. These symptoms appear after 7 to 11 days, when the animals become lethargic and refuse to eat. They also noted considerable hair loss, and the further course of radiation illness depended on the degree of injury to internal organs. In 1967 Bell¹¹ reported that the omasum and rumen were the organs most severely affected in sheep given ^{144}Ce — ^{144}Pr chloride solution in

their feed. These data on sheep were obtained for levels at which 50% of the sheep developed diarrhea and half of those with diarrhea died.

More recently Bell et al.^{1,2} showed that feeding an insoluble fallout simulant can be lethal to sheep and that it severely affects the productivity of survivors. The simulant consisted of ⁹⁰Y fused to 88- to 175- μ sand to provide about 10 mCi/g of sand. The primary symptoms from feeding 0.8 to 3.2 mCi/kg of body weight were anorexia, diarrhea, weight loss, and pyrexia. Sufficient radioactive sand had "pocketed" in areas of the rumen and abomasum to cause ulceration and fibrin infiltration of the mucosa. Readings from microdosimeters implanted in the "pockets" of the abomasum averaged eight times as high as those in the small and large intestine. No gross lesions were found in the large intestine of the sheep. These data demonstrate the importance of using characteristic insoluble fallout simulants at levels to cause some deaths instead of depending on dosimeter measurements. An animal suffering from GI radiation injury will react quite differently physiologically from an animal under little or no radiation stress. Anorexia was accompanied by rumen stasis, which prevented the normal passage of ingesta. This was followed by severe diarrhea and weight loss.

Fallout irradiation injury to skin was observed^{1,3} in cattle exposed at Alamogordo in 1945 and in cattle at the Nevada Test Site (D. S. Barth, personal communication, 1970). Minor-to-severe beta-irradiation injuries occurred although no lethalties were observed within 150 days in any of these cattle. Skin-irradiation injury appears similar to thermal burns except that the visible effects of thermal burns are immediate and the obvious effects of beta skin irradiation may not be observed for 3 or 4 weeks.

The skin-irradiation damage to the Alamogordo cattle was described by Brown, Reynolds, and Johnson^{1,3} as the development of areas or zones of hyperkeratosis which formed plaques and cutaneous horns on the skin of the dorsa of the cattle. After 15 years three of the exposed cows developed squamous cell carcinoma of the skin in irradiation-damaged areas. In areas less severely affected, there was some alopecia and graying of the red hair. The location of these cattle in relation to the bomb is not known, but it is estimated that the radiation dose was 150 R gamma and 37,000 rads beta to the dorsal skin. There was no evidence of radiation damage on the ventral surfaces as has been predicted to result from the beta-bath exposure from radioactive fallout on the ground.

Combined Radiation Effects

Research on the effects of combining beta with gamma irradiation has recently been initiated with sheep (31 kg) and cattle (184 kg) at the UT-AEC Agricultural Research Laboratory. Results summarized in Table 1 show that these animals were much more susceptible to the combined radiation sources than to any one alone. Radiation levels chosen were slightly less than those expected to cause death from the ingested fallout simulant or the whole-body

Table 1
SHEEP AND CATTLE 60-DAY MORTALITY
AFTER EXPOSURE TO SIMULATED FALLOUT

Treatment	Number of deaths*	
	Sheep	Cattle
Control	0	0
Whole body (WB) 240 R ^{60}Co gamma at 1 R/min	0	0
Skin		
57,000 rads beta	1†	0
Gastrointestinal (GI)‡	1	2
GI + Skin	0	2
WB + Skin	0	0
WB + GI	3	5
WB + GI + Skin	4	8

*Eight animals were exposed to each treatment.

†Accidental death.

‡Sheep were fed 2.4 mCi of ^{90}Y -labeled sand per kilogram of body weight, and cattle were fed 2.0 mCi of ^{90}Y -labeled sand per kilogram of body weight.

gamma radiation. Using the NAS-NRC procedure,⁸ we calculated the ingested level of 2.4 mCi per kilogram of body weight to simulate a 7% forage retention for sheep and that of 2 mCi/kg to simulate 9% forage retention for cattle exposed to 240-R gamma radiation. Whole-body gamma from six ^{60}Co sources¹⁴ was used to give a bilateral air dose of 240 R at 1 R/min. Skin irradiation of the dorsa of these animals from flexible, sealed, beta-irradiation sources¹⁵ gave a dose of approximately 57,000 rads to the surface of the hair or wool. The 7 to 9% forage retention levels are well within the range of 5 to 23% retention of 88- to 175- μ particles on alfalfa and pasture grasses.¹⁶ Exposure of 12% of the body surface of sheep and 8% of the body surface of cattle provided a beta-to-gamma ratio comparable to the ratios estimated for the cattle exposed in 1945 at Alamogordo.¹³ Skin irradiation alone under these conditions did not affect feed intake, but after 60 days skin-irradiated sheep weighed only 80% as much as the controls and as those exposed only to whole-body gamma irradiation. Sheep surviving a combination of whole-body gamma and skin and GI beta weighed only 60% as much as the controls in 60 days. Whole-body gamma radiation of 240 R at 1 R/min affected neither body weight nor feed consumption of sheep and cattle when no other radiation was given.

The importance of considering combined irradiation effects on survival of grazing livestock is convincing for the simulated-fallout conditions used to obtain the data summarized in Table 1. However, grazing livestock might be exposed to many different fallout conditions that would alter both mortality

and productivity. For damage-assessment calculations, additional data are needed for alternative models, such as using different-size fallout-simulant particles, lower beta-energy exposures, different forage-retention levels, effects of absorbed isotopes (principally iodine), and different levels and rates of gamma exposures.

No data were found on the combined effects of beta and gamma irradiation in horses, swine, or poultry. Grazing equine might be severely affected by ingested fallout, but the damage would probably be greatest in the stomach and cecum. Alexander¹⁷ described the gastric and cecal contractions in horses which would probably cause some stratification of ingesta, with the heavier fallout particles collecting in pockets as observed in the rumen and abomasum of cattle and sheep. Swine are normally fed in drylot and probably would not ingest enough radioactivity to increase losses that would occur above those from gamma irradiation alone. Data are not available on pasture-fed swine, but the effect would probably be minor. Ingested fallout would not be expected to be a problem in poultry production.

Data on lethality are meager for food-producing animals under simulated-fallout conditions. Estimates listed in Table 2 were obtained from published data

Table 2
ESTIMATED LIVESTOCK LETHALITY ($LD_{50/60}$) FROM
FALLOUT-GAMMA-RADIATION EXPOSURE ALONE AND IN
COMBINATION WITH BETA RADIATION*

Animal	Total gamma exposure, R		
	Barn (WB)	Pen or corral (WB + Skin)	Pasture† (WB + Skin + GI)
Cattle	500	450	180
Sheep	400	350	240
Swine	640	600‡	550‡
Equine	670	600‡	350‡
Poultry	900	850‡	800‡

*Data from M. C. Bell, L. B. Sasser, and J. L. West. Simulated-Fallout-Radiation Effects on Livestock, this volume.

†Assumed forage retention of 7 to 9%.

‡No data available; estimates are based on grazing habits, anatomy, and physiology of species.

on gamma lethality for the various species. Estimates for combined effects on cattle and sheep were made from research in progress at UT-AEC. Estimates for combined effects on swine, horses, and poultry were made by considering the grazing habits, anatomy, and physiology of these species since no data are available.

RADIATION EFFECTS ON LIVESTOCK PRODUCTIVITY

Meat and Milk Production

Gamma radiation at levels below the lethal dose and at rates expected from fallout radiation would have minor to no measurable effects on livestock productivity. Animals surviving gamma radiation at dose rates of 0.1 to 2 R/min gain just as well as the controls,^{7,18} and irradiated dairy cows produce almost as much milk as controls.^{19,20} Lactation can, however, be reduced by ¹³¹I destruction of thyroid tissue, as shown by Miller and Swanson,²¹ who gave one of each pair of identical-twin dairy heifers doses of 99 to 180 μ Ci of ¹³¹I per kilogram of body weight. These heifers averaged 305 kg at the time of treatment, and in their first lactation they averaged 54% of the production of the untreated twins. Radioisotopes of iodine are the major absorbed fission products of concern in early fallout during the first few weeks after detonation. However, grazing livestock are more likely to consume ¹³¹I over a period of several weeks than in a single ingestion as described. Garner²² estimated from data on sheep that cattle consuming 1500 μ Ci of ¹³¹I daily would show a decline in milk yield and reduced viability of offspring. More-recent data indicate that cattle are less sensitive to ¹³¹I injury than sheep.

Radioisotopes of iodine represent 15% of the total radioactivity 24 hr after fission, but most of these are short-lived isotopes.²³ Actual ¹³¹I contributes only 0.8% at H + 24 hr and 3.5% at H + 4 days. Thyroid uptake by dairy cows at 24 hr reaches about 70% of the maximum uptake, which occurs at 72 hr.²⁴ Thus the decay factors and the rate of thyroid uptake would reduce the ¹³¹I equivalent effective values to about 4% for H + 24 hr. The effectiveness of the radioiodine would be further reduced by the low solubility of early fallout. Comar, Wentworth, and Lengemann,²⁵ using a double tracer technique in six cows, found only 20% as much radioiodine from a fallout simulant in milk as from a soluble radioiodine. Ekman, Funkqvist, and Greitz²⁶ report 10% solubility for early fallout.

Neutron irradiation of 500 to 750 rads severely reduced feed intake, body weight, and milk production of dairy cows. Those exposed to the higher levels died within 40 days.¹⁹ Nonlethal neutron irradiation of 300 rads significantly reduced growth of swine with no effect on feed intake.²⁷ However, neutron irradiation is not expected to be of significance compared with fallout radiation.

Fallout-simulant beta irradiation of the GI tract of cattle and sheep severely reduces feed intake and weight. Animals surviving this type of radiation usually return to normal feed consumption within 60 days, but considerably more time is required to recover the weight loss. In a UT-AEC study involving 32 sheep (31.1 ± 0.6 kg) fed a fallout simulant, five of the survivors developed abomasal hernias, and one developed a rumen fistula in the areas most severely affected by the beta radiation. These lesions did not develop until 60 days after treatment when the animals had regained appetites. Some of the lesions ruptured to the

outside as late as 300 days after treatment. Rumen and abomasal tissue around these openings was firmly attached to the body cavity with no evidence of peritonitis and/or bacterial invasion. There is no evidence that these animals could not be used for food, especially if food were scarce. Preliminary results from experiments with cattle indicate that hernias and fistulae would not be a problem, because of the greater thickness of the tissue involved.

At present the research in progress with 184-kg beef calves indicates that feeding 2 mCi of ^{90}Y -labeled sand per kilogram of body weight for 3 days severely affects feed intake and body weight, but no calves died from either 240-R gamma at 1 R/min or from beta irradiation of 8% of the body surface over the dorsum. When these three treatments were combined, however, all calves died within 60 days (Table 1).

Neither beta irradiation to the skin nor whole-body gamma irradiation had an effect on feed intake, but weight gain was considerably reduced by skin irradiation of both sheep and cattle. During the winter months the loss of body heat would be expected to be much greater in a colder climate than in Tennessee, where the experimental animals had access to shelter. During the warm months the fly problem required frequent attention, starting about 30 days after skin irradiation. The fly-larvae damage could have caused increased animal losses if insecticides had not been used.

It appears that most surviving sheep and cattle suffering from skin injury from fallout or from GI injury in combination with whole-body gamma irradiation could eventually be used for food under emergency conditions. Research in progress at UT-AEC (Griffin and Eisele, personal communication, 1970) indicates that bacterial invasion is not a problem in swine dying from gamma irradiation given at a dose rate of 1 R/min. Until more data are available, it is recommended that, for 15 to 60 days after exposure to levels to cause some mortality, only muscle meat from surviving animals be used for food.

Poultry

A review by Wetherbee²⁸ showed that young irradiated chicks developed hypotension and that the survivors had a reduced rate of growth. Egg production was reduced only when layers were exposed to 600 R and above from ^{60}Co at 0.9 R/min, and the survivors gradually regained their normal levels of egg production. Most of the reduction in egg production occurred between days 11 and 20. More recently Maloney and Mraz²⁹ showed that survivors of a group of White Leghorn hens exposed to 400 to 800 R ^{60}Co at 5 R/min had a 10-day temporary drop in egg production starting 10 days after exposure. This drop in egg production lasted 40 days when the total dose remained constant and the dose rate was increased to 45 R/min.

Exposure of incubated, fertilized eggs to less than 80 R of X rays accelerated the development of the embryo, but higher doses retarded development. Hatchability increases of 10% over the controls have been claimed by using

exposures of up to 30 R of X rays.²⁸ The uncubated, fertile egg is relatively resistant to gamma-radiation effects. Sensitivity increased the first 3 days of development then decreased through day 12, when it leveled off at an LD_{50/30} of about 750 R. A second period of radiation sensitivity was found at incubation day 18.

Beta irradiation of the GI tract and skin of poultry would not be expected to be a problem in poultry production. Even the few turkeys on the range depend mostly on feed supplements and very little on range pasture.

Reproduction

Studies of radiation effects on reproduction in food-producing animals have rightly been concentrated on gamma radiation. Neither ingestion nor skin irradiation from beta particles would be expected to have a direct effect on reproduction, but there could be abscopal effects in addition to anorexia and weight loss.

Whole-body ⁶⁰Co gamma radiation of beef heifers has not affected the long-term reproductive performance of 179 survivors for 8 years postirradiation.¹⁸ Acute radiation sickness and mortality occurred in a large number of these cattle exposed to 200 to 400 R at 0.7 R/min from ⁶⁰Co; however, there were no differences that could be attributed to radiation in the performance of offspring in comparison with offspring of the 40 controls. Neither did exposure of beef cows to the first atomic bomb at Alamogordo have a measurable effect on reproductive performance. The ovaries, which are well protected in adult cows, would receive about 40% of the air dose. In addition, it has been estimated that over twice the lethal level given directly to the ovaries would be required to sterilize females.^{30,31} There is a high percentage of bone deformities in offspring of pregnant females gamma irradiated with 100 rads or more during a short period in their gestation: gestation days 32 to 34 in cattle and 22 to 24 in sheep. At this stage of development, the limb buds are just starting to form in the embryos, and they are very sensitive to gamma radiation.^{18,32,33}

The developing fetus concentrates ¹³¹I much more than its dam,³⁴ and fetal thyroid takes up almost as much ¹³¹I as the dam thyroid.³⁵ However, thyroid insufficiency can be counteracted by using thyroxin or by feeding iodinated casein if the thyroid is damaged by ¹³¹I irradiation.

Males surviving fallout gamma radiation at levels of 200 R or more would be expected to be temporarily sterile starting about 6 weeks after exposure, but this would last for only a few weeks.³⁶ Since a large number of females can be bred to one male either naturally or through artificial insemination, male sterility is not expected to be a problem in food-producing animals.

Work

Shetland ponies surviving gamma-radiation exposure of 50 R/week at 25 R/hr for a total of 650 R have been used in the study of radiation effects on

work performance and several other physiological parameters. After recovery from the early radiation effects, the irradiated ponies performed as well as their control teammates over a period of 2 years.¹⁸

Genetic and Life-Span Effects

Although gamma-irradiated animals show an increase in chromosome aberrations,³⁷ the chance of observing genetic changes in offspring of large animals is rather small. Mullaney and Cox³⁸ reported that pigs sired by boars after they had recovered from 300 R of X rays to the testes were not adversely affected. In these studies involving over 3000 litters of pigs, irradiation of the maternal grandsire decreased ($P < 0.01$) the number of stillborn pigs in one of the two breeds studied. Survivors of the lifetime Hereford cows at UT-AEC (discussed in the section on reproduction) show no indication of genetic effects on offspring over the past 8 years of observation.¹⁸

Since unproductive food-producing-breeding animals are normally culled and used for food, there is little concern for life-span effects in large animals unless there is a shortage of breeding animals. From the limited data available,¹⁸ it appears that life-span and productive life-span of swine and cattle are slightly reduced in long-term survivors of whole-body radiation. Life-span lengthening of 37% in males and 16% in females has been reported in 10 generations of mice irradiated from drinking water containing 1 μCi of ^{90}Sr and 4 μCi of ^{137}Cs per liter. These mice also showed improved reproductive efficiency in the study using 255 litters. Mice drinking water with 100 times these concentrations of ^{90}Sr and ^{137}Cs showed adverse effects on both life-span and reproduction.³⁹ No data were found on large animals subjected to these types of tests.

COUNTERMEASURES

The countermeasures that can be recommended to save the largest number of grazing food-producing animals in a heavy fallout field are sheltering and using stored feed. In an area where gamma irradiation alone would be lethal to a small percentage of grazing animals, any shelter that groups and restricts the animals provides mutual shielding,⁴⁰ prevents them from grazing pastures contaminated with early fallout, and probably ensures that most cattle and sheep would survive instead of dying from exposure to a combination of whole-body gamma and beta irradiation to the skin and GI tract.

Shelters providing large protection factors would be desirable but are not available on most farms, as shown in a pilot survey in Tennessee.⁴¹ Buildings available for shelters on these farms gave an average protection factor of only 1.8, but the real importance of these buildings would be to prevent fallout damage to the skin, to prevent ingestion of forage contaminated with high levels of fallout, and to provide mutual shielding.

The limited data available show that preventing livestock from eating contaminated feed during the first 72 hr after fallout arrival is one of the most important countermeasures available. Anorexia, diarrhea, and GI injury and perhaps thyroid injury could greatly increase the lethality percentage. Weight and productivity of the survivors of grazing livestock would be severely affected. If no shelter were available, confining animals in a fenced corral, ravine, or woods would be desirable to increase mutual shielding and prevent ingestion of forage contaminated with early fallout.

Skin damage from fallout increases heat loss and parasitic problems but is probably of less consequence than beta ingestion and whole-body gamma damage. The USSR textbook¹⁰ recommends blankets and canvas as improvised means of protecting the skin of animals. It was also suggested that valuable breeding animals could get added protection from a chemically treated, protective muzzle bag that would prevent the animal from eating contaminated feed and reduce the radioactivity inhaled when animals are being taken out of a contaminated area.

ACKNOWLEDGMENTS

The UT-AEC Agricultural Research Laboratory is operated by the Tennessee Agricultural Experiment Station for the U. S. Atomic Energy Commission under Contract AT-40-GEN-242.

This work was supported in part by the U. S. Office of Civil Defense and is published with the permission of the Dean of the University of Tennessee Agricultural Experiment Station, Knoxville.

REFERENCES

1. N. P. Page, The Effect of Dose Protraction on Radiation Lethality of Large Animals, in Proceedings of a Symposium on Dose Rate in Mammalian Radiation Biology, Apr. 29-May 1, 1968, Oak Ridge, Tenn., D. G. Brown, R. G. Cragle, and T. R. Noonan (Eds.), USAEC Report CONF-680410, pp. 12.1-12.23, UT-AEC Agricultural Research Laboratory, July 12, 1968.
2. E. J. Ainsworth, N. P. Page, J. F. Taylor, G. F. Leong, and E. T. Still, Dose Rate Studies with Sheep and Swine, in Proceedings of a Symposium on Dose Rate in Mammalian Radiation Biology, Apr. 29-May 1, 1968, Oak Ridge, Tenn., D. G. Brown, R. G. Cragle, and T. R. Noonan (Eds.), USAEC Report CONF-680410, pp. 4.1-4.21, UT-AEC Agricultural Research Laboratory, July 12, 1968.
3. D. G. Brown and R. G. Cragle, Some Observations of Dose-Rate Effect of Radiation on Burros, Swine, and Cattle, in Proceedings of a Symposium on Dose Rate in Mammalian Radiation Biology, Apr. 29-May 1, 1968, Oak Ridge, Tenn., D. G. Brown, R. G. Cragle, and T. R. Noonan (Eds.), USAEC Report CONF-680410, pp. 5.1-5.16, UT-AEC Agricultural Research Laboratory, July 12, 1968.
4. M. T. Case and J. Simon, Whole-Body Gamma Irradiation of New-Born Pigs: The $LD_{50/30}$, *Amer. J. Vet. Res.*, **31**: 113-115 (1970).
5. D. G. Brown, Clinical Observations on Cattle Exposed to Lethal Doses of Ionizing Radiation, *J. Amer. Vet. Med. Ass.*, **140**: 1051-1055 (1962).

6. F. W. Chambers, C. R. Biles, L. J. Bodenlos, and J. H. Dowling, Mortality and Clinical Signs in Swine Exposed to Total-Body Cobalt-60 Gamma Irradiation, *Radiat. Res.*, **22**: 316-333 (1964).
7. R. S. Lowrey and M. C. Bell, Whole-Body Irradiation in the Young Pig: Growth, Hematology and Metabolism of ^{45}Ca and ^{89}Sr , *Radiat. Res.*, **23**: 580-593 (1964).
8. National Academy of Sciences-National Research Council, Damage to Livestock from Radioactive Fallout in Event of Nuclear War, Publication 1078, Washington, D. C., 1963.
9. M. M. Nold, R. L. Hayes, and C. L. Comar, Internal Radiation Dose Measurements in Live Experimental Animals, *Health Phys.*, **4**: 86-100 (1960).
10. *Civil Defense in Rural Regions*, Military Publishing House of USSR Ministry of Defense, Moscow, 1965.
11. M. C. Bell Airborne Radionuclides and Animals, in *Agriculture and the Quality of Our Environment*, N. C. Brady (Ed.), American Association for the Advancement of Science, Symposium No. 85, pp. 77-90, Washington, D. C., 1967.
12. M. C. Bell, L. B. Sasser, J. L. West, and L. Wade, Jr., Effects of Feeding ^{90}Y -Labeled Fallout Simulant to Sheep, *Radiat. Res.*, **43**: 71-82 (1970).
13. D. G. Brown, R. A. Reynolds, and D. F. Johnson, Late Effects in Cattle Exposed to Radioactive Fallout, *Amer. J. Vet. Res.*, **27**: 1509-1514 (1966).
14. J. S. Cheka, E. M. Robinson, L. Wade, Jr., and W. A. Gramly, The UT-AEC Agricultural Research Laboratory Variable Gamma Dose-Rate Facility, *Health Phys.*, **20**: 337-340 (1971).
15. M. C. Bell, Flexible Sealed ^{90}Sr - ^{90}Y Sources for Large Area Skin Irradiation, *Int. J. Appl. Radiat. Isotop.*, **21**: 42-43 (1970).
16. J. E. Johnson and A. I. Lovaas, Deposition and Retention of Simulated Near-In Fallout by Food Crops and Livestock, First Technical Progress Report, Colorado State University, Fort Collins, Colo., 1969.
17. F. Alexander, Digestion in the Horse, in *Progress in Nutrition and Allied Sciences*, D. P. Cuthbertson (Ed.), pp. 259-268, Oliver and Boyd, Ltd., Edinburgh, 1963.
18. UT-AEC Agricultural Research Laboratory, Annual Progress Report, Jan. 1-Dec. 31, 1968, USAEC Report ORO-672, October 1969.
19. R. G. Cragle, J. K. Miller, E. W. Swanson, and D. G. Brown, Lactation and Radionuclide Metabolism Responses of Dairy Cattle to Lethal Doses of Gamma and Neutron Radiation, *J. Dairy Sci.*, **48**: 942-946 (1965).
20. E. W. Swanson, R. G. Cragle, and J. K. Miller, Effects of Irradiation upon Lactation, *J. Dairy Sci.*, **48**: 563-568 (1965).
21. J. K. Miller and E. W. Swanson, Effects of Iodine-131 Thyroid Damage on Lactation and Thyroid Function in the Bovine, *J. Dairy Sci.*, **52**: 95-100 (1969).
22. R. J. Garner, Environmental Contamination and Grazing Animals, *Health Phys.*, **9**: 597-605 (1963).
23. R. V. Petrov, V. N. Pravetskii, Yu. S. Stepanov, and M. I. Shal'nov, Radioactive Fallout. Physics, Biological Effects, and Protective Measures, USAEC Report AEC-tr-6634, translation of Zashchita ot Radioaktivnykh Osadkov, Gosudarstvennoe Izdatel'stvo, Meditsinskoi Literatury, Moscow, 1963.
24. E. W. Swanson, F. W. Lengemann, and R. A. Monroe, Factors Affecting the Thyroid Uptake of ^{131}I in Dairy Cows, *J. Anim. Sci.*, **16**: 318-327 (1957).
25. C. L. Comar, R. A. Wentworth, and F. W. Lengemann, A Study of Metabolism of Selected Radionuclides Fed in Various Physical Forms to Dairy Cows, Final Report, OCD Report TRC-67-33, Cornell University, Ithaca, N. Y., 1967.
26. L. Ekman, B. Funkqvist, and U. Greitz, Beta- and Gamma-Dose Measurements in the Gastrointestinal Tract of Goats with LiF Dosimeters After a Single Intake of Simulant Mixed Fission Products, Swedish Report FOA-4-4418, March 1970.

27. H. Rosas and M. C. Bell, Effects on Swine of Unilateral Neutron Irradiation, Calcium and Zinc, *Radiat. Res.*, **39**: 164-176 (1969).
28. D. K. Wetherbee, Gamma Irradiation of Birds' Eggs and the Radiosensitivity of Birds, USAEC Report TID-24521, Massachusetts Agricultural Experiment Station, October 1966.
29. M. A. Maloney and F. R. Mraz, The Effect of Whole-Body Gamma Irradiation on Survivors' Egg Production in the White Leghorn and Bobwhite Quail, *Poultry Sci.*, **48**: 1939-1944 (1969).
30. B. H. Erickson, Radioresponse of the Prepuberal Porcine Ovary, *Int. J. Radiat. Biol.*, **13**: 57-67 (1967).
31. B. H. Erickson, Effect of Gamma Radiation on the Prepuberal Bovine Ovary, *Radiat. Res.*, **31**: 441-451 (1967).
32. B. H. Erickson and R. L. Murphree, Limb Development in Prenatally Irradiated Cattle, Sheep, and Swine, *J. Anim. Sci.*, **23**: 1066-1071 (1964).
33. A. F. McFee, R. L. Murphree, and R. L. Reynolds, Skeletal Defects in Prenatally Irradiated Sheep, Cattle and Swine, *J. Anim. Sci.*, **24**: 1131-1135 (1965).
34. P. W. Aschbacher, R. G. Cragle, E. W. Swanson, and J. K. Miller, Metabolism of Oral Iodine and 3,5-diiodosalicylic Acid in the Pregnant Cow, *J. Dairy Sci.*, **49**: 1042-1045 (1966).
35. J. K. Miller, E. W. Swanson, P. W. Aschbacher, and R. G. Cragle, Iodine Transfer and Concentration in the Parturient Cow, Fetus and Neonatal Calf, *J. Dairy Sci.*, **50**: 1301-1305 (1967).
36. B. H. Erickson, Radiation Effects on Gonadal Development in Farm Animals, *J. Anim. Sci.*, **24**: 568-583 (1965).
37. A. F. McFee, M. W. Banner, and Mary N. Sherrill, Influence of Animal Age on Radiation-Induced Chromosome Aberrations in Swine Leukocytes, *Radiat. Res.*, **41**: 425-435 (1970).
38. P. D. Mullaney and D. F. Cox, Effects of Paternal X-Irradiation on Litter Size and Early Postnatal Mortality in Swine, *Mutat. Res.*, **9**: 337-340 (1970).
39. K. Nishio, T. Megumi, and M. Yonezawa, Effects of ^{137}Cs and ^{90}Sr Administered Continuously and Through Generations upon Mice. VI. *Ann. Rep. Radiat. Center Osaka Prefect.*, **9**: 86-93 (1968).
40. K. Mills and K. Evans, Protecting Livestock from Radioactive Fallout, University of Kentucky Extension Service Miscellaneous Publication 338, 1966.
41. S. A. Griffin, in Civil Defense Research Project. Annual Progress Report March 1968-March 1969, USAEC Report ORNL-4413(Pt. 1), pp.94-96, Oak Ridge National Laboratory, October 1969.

THE EFFECTS OF EXTERNAL GAMMA RADIATION FROM RADIOACTIVE FALLOUT ON PLANTS, WITH SPECIAL REFERENCE TO CROP PRODUCTION

A. H. SPARROW, SUSAN S. SCHWEMMER, and P. J. BOTTINO
Brookhaven National Laboratory, Upton, New York

ABSTRACT

This paper describes the major problems involved in attempting to predict for economically useful plants the degree of radiation damage that would arise from exposure to high-level radioactive fallout. Since almost no data exist on the deleterious effects inflicted on crops by actual fallout radiation, it is necessary to extrapolate from the existing radiobotanical data concerned with the effects of gamma radiation on survival and yield of plants.

A number of factors can modify the effects of the radiation and hence influence the accuracy of predictions of postattack injury. The most important variables are (1) species differences in interphase chromosome volume (the larger this value, the more sensitive the plant), (2) exposure rate (high rates are more effective than lower rates), (3) stage of development of the plant (a complex and difficult variable to assess), (4) postirradiation time (generally the longer the time, the greater the degree of damage), and (5) numerous environmental factors such as moisture, temperature, light, competition, etc., which normally modify plant growth and yield. These factors, acting singly or in various combinations, can have a considerable effect on the radiation response and thereby make more difficult the prediction of postattack injury.

Survival and yield data obtained from irradiation of growing plants are presented for many species. The most useful values in comparing sensitivities are LD_{10} , LD_{50} , and LD_{90} (exposures required to reduce survival by 10, 50, and 90%), and YD_{10} , YD_{50} , and YD_{90} (exposures required to reduce yield by 10, 50, and 90%). A log-log regression of LD_{10} vs. YD_{50} for 36-hr fallout-decay-simulation (FDS) gamma exposures has a slope not significantly different from +1; this indicates that, in general, an exposure producing an LD_{10} will reduce yield by 50%. Other LD_{10} values may also be predicted from regressions of interphase chromosome volume on LD_{10} .

Predicted YD_{50} values following FDS exposures are given for 89 crop plants and for 82 woody plants for a 16-hr constant-rate exposure. Using these predictions and the available radiobiological data, we can draw some conclusions concerning the vulnerability of crop plants to fallout radiation. The cereals (wheat, barley, oats, and maize), which are probably our most important group of crop plants, would be the most sensitive, having YD_{50} values ranging from about 1 to 4 kR (rice is much more resistant). The legumes (peas and beans) include both sensitive and resistant species, having YD_{50} values ranging from less than 1 to 12 kR. Root crops (onions, garlic, beets, potatoes, and radishes) have a wider range in

sensitivity; YD_{50} values range from 1 to 16 kR. For pasture and forage crops, YD_{50} varies from 2 to 20 kR. Of the herbaceous crop species, 70% fall in the predicted sensitivity range between 4 and 16 kR. Woody species have a range of predicted LD_{50} values between about 0.4 and 8 kR, the gymnosperms predominating below 2 kR.

These predictions are for average conditions only. We still lack a significant amount of radiobiological data required to make confident predictions of the expected response of many species to high-level fallout-gamma exposure. Also, inadequate information about beta-radiation injury and its possible interaction with gamma radiation makes extrapolation to actual fallout conditions even more difficult.

Plants in areas receiving radioactive fallout will be exposed to two types of external radiation, gamma and beta; the relative biological effectiveness of these two types of radiation was recently shown¹ to be approximately 1. In areas of heavy fallout, either type of radiation alone could seriously reduce the growth or yield of plants, at least at certain stages of plant development. Under conditions of lighter fallout, the combined exposures from both types of radiation could also produce very serious effects, up to complete destruction of some crops. However, this report reviews only known or expected effects of gamma radiation on various species of plants given a range of exposures at one or more stages in their life cycles. The hazards of direct contamination of foodstuffs by fallout radionuclides have been discussed elsewhere.²⁻⁵ The long-lived nuclides are not now considered as serious a hazard as was previously thought.⁶ Although the dislocations in agricultural practices and food distribution associated with other disturbances and/or the reduced availability of manpower and horsepower which would result from a nuclear war are important in the overall context of postattack recovery, we shall not consider them here.

Previous studies on the effects of gamma radiation on growing plants are many and varied.⁷⁻¹⁴ Unfortunately, however, many different exposure rates have been given under differing conditions with various criteria of effect being used. No previous attempt has been made to assemble the majority of the pertinent data and devise a means of presenting them in a uniformly comprehensible manner. This paper reviews the major modifying factors, such as exposure rate and duration, stage at irradiation, environmental conditions, etc.; surveys the available pertinent data; indicates what currently appear to be the general trends of response to fallout or simulated-fallout gamma radiation; and predicts the probable responses for plant species for which no data are currently available.

BACKGROUND INFORMATION

The wide range of radiosensitivity among different plant species to external X or gamma radiation is well documented.^{11,12,14-20} Radiosensitivity varies by at least 100-fold among species and by over 50-fold within a species irradiated at different stages. Certain stages of flower-bud development are known to be

much more sensitive than others and also more sensitive than meristem cells in the vegetative stage.²⁰⁻²² Radiation injury expresses itself after a few days, weeks, or, in some cases, years as abnormal shape or appearance, reduced growth or yield, loss of reproductive capacity, sometimes wilting, and, finally, at the higher exposures death. Although we recognize the importance of genetic effects, we shall not attempt here to survey the vast body of literature on this subject.

It is now known that the wide range in sensitivity of plant species irradiated and grown under uniform experimental conditions can be attributed largely to variation in the size of the chromosomes of the plants.^{1,11,16,19,23-29} A direct relation between chromosome size (measured as the average volume of an interphase chromosome) and sensitivity to gamma radiation given under specified conditions has been established, showing that, as the size of the chromosomes increases from one species to another, the amount of radiation required to produce a specified effect decreases (Figs. 1 and 2). The consistency of this relation is the basic premise on which our predictions are based [see Radiosensitivity Predictions (Based on ICV Data)].

When plants are irradiated under uniform conditions with a range of exposures which, depending on their magnitude, will produce measurable decreases in yield and/or survival, response curves can be obtained. Values not actually observed to occur at any of the exposures given can be calculated from these data. Survival end points that have been found to be most useful in describing radiation effects on plants are LD₁₀, LD₅₀, LD₉₀, and LD₁₀₀; the exposures required to reduce plant survival by 10, 50, 90, and 100%, respectively. Similarly, for yield reduction the particular end points of most use are YD₁₀, YD₅₀, and YD₉₀, the exposures required to reduce growth or yield by 10, 50, and 90%, respectively.

There is extensive literature on growth stimulation in plants after exposure to ionizing radiation, and some investigators claim statistically significant increases in yield after exposures usually referred to as low doses, although a wide range of exposures is used. Surveys of the available data have been given in various publications.^{7,30-33} In our opinion the probability of beneficial effects of fallout radiation on crop yield is so far outweighed by the probability of deleterious effects that no further consideration will be given here to possible enhanced growth or yield.

A particularly useful relation between a survival end point and a yield end point is shown in Fig. 3. For all practical purposes, for the plant species studied, the exposure that produces an LD₁₀ also produces a YD₅₀. Thus the determination of the LD₁₀ for any species should provide a fair approximation of the YD₅₀. This is an advantage because determination of YD₅₀ generally requires experiments of greater magnitude, with better facilities and more manpower. Also, survival data for a crop for which no yield data exist can be converted to an estimated effect on yield.

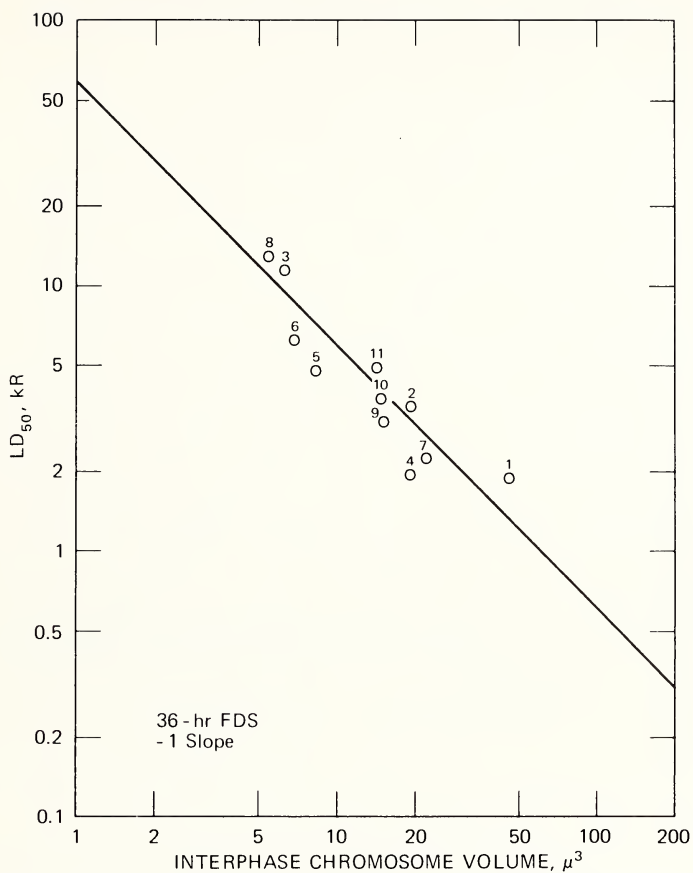

Fig. 1 Log-log regression of LD_{50} against ICV for 10 species of economic plants given a 36-hr FDS exposure as young seedlings.

- | | | |
|----------------------------|-----------------------------|----------------------------|
| 1 <i>Allium cepa</i> | 5 <i>Lactuca sativa</i> | 9 <i>Triticum aestivum</i> |
| 2 <i>Avena sativa</i> | 6 <i>Phaseolus limensis</i> | 10 <i>Zea mays</i> |
| 3 <i>Brassica oleracea</i> | 7 <i>Pisum sativum</i> | 11 <i>Zea mays</i> |
| 4 <i>Hordeum vulgare</i> | 8 <i>Raphanus sativus</i> | |

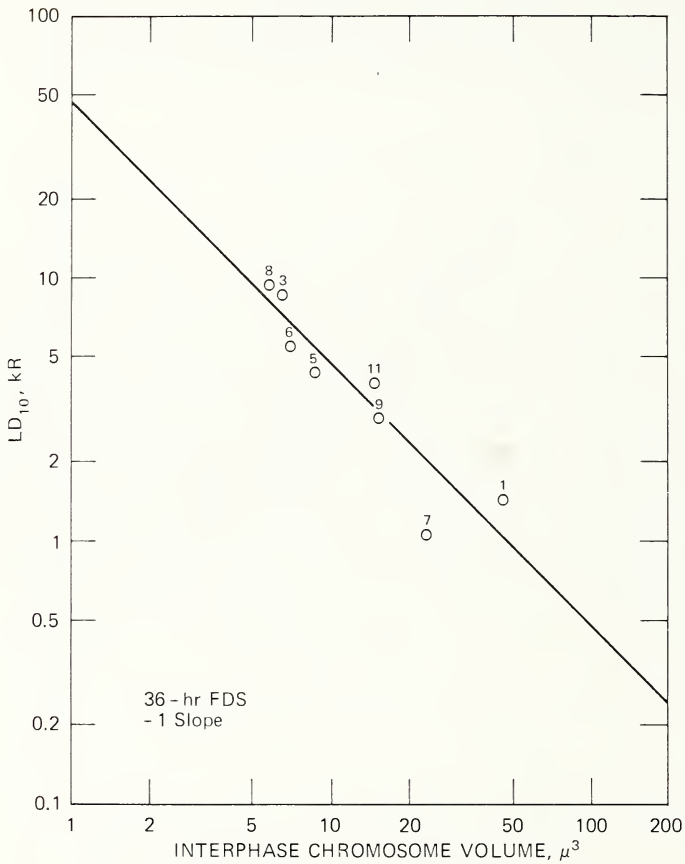

Fig. 2 Log-log regression of LD_{10} against ICV for eight species of economic plants given a 36-hr FDS exposure as young seedlings.

- | | |
|-----------------------------|----------------------------|
| 1 <i>Allium cepa</i> | 7 <i>Pisum sativum</i> |
| 3 <i>Brassica oleracea</i> | 8 <i>Raphanus sativus</i> |
| 5 <i>Lactuca sativa</i> | 9 <i>Triticum aestivum</i> |
| 6 <i>Phaseolus limensis</i> | 11 <i>Zea mays</i> |

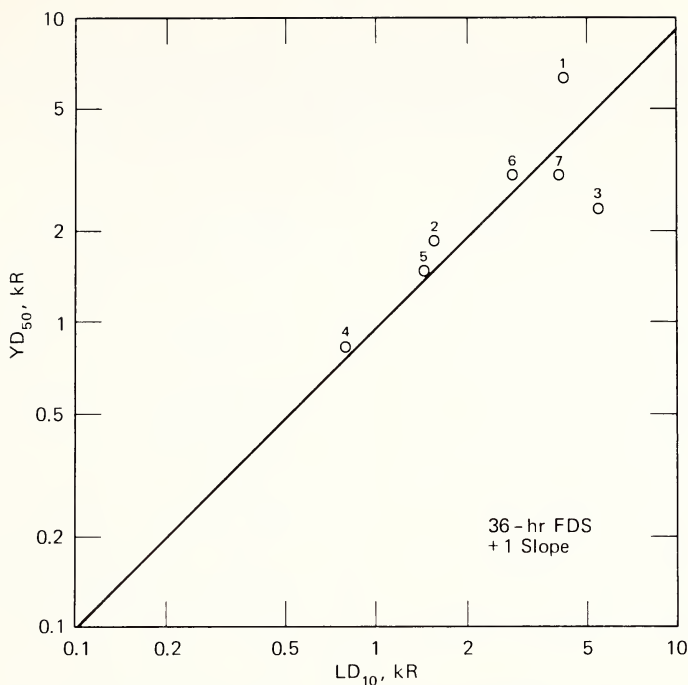

Fig. 3 Log-log regression of YD_{50} against LD_{10} for six species of economic plants given a 36-hr FDS exposure as young seedlings.

- | | |
|-----------------------------|----------------------------|
| 1 <i>Cucurbita pepo</i> | 5 <i>Pisum sativum</i> |
| 2 <i>Hordeum vulgare</i> | 6 <i>Triticum aestivum</i> |
| 3 <i>Phaseolus limensis</i> | 7 <i>Zea mays</i> |
| 4 <i>Pisum sativum</i> | |

Other effects of importance for consumable economic crops are changes in starch,³⁴ sugar (personal communication from R. S. Russell and Ref. 35), and protein³⁶ content and minor variations such as differences in taste,³⁷⁻³⁹ shape,⁴⁰⁻⁴² color,⁴³ and perhaps wholesomeness.⁴⁴

MODIFYING FACTORS

General Considerations

Basic research in radiobiology has shown that there are many biological, radiological, and environmental factors that determine or modify radiosensitivity. A partial list of these factors is given in Table 1; no indication of the extent or direction of the change in sensitivity is given, however. To emphasize the possible significance of such factors, we have made estimates of the degree of

Table 1
BIOLOGICAL, RADIOLOGICAL, AND ENVIRONMENTAL
FACTORS THAT CONTRIBUTE TO VARIATIONS
IN RADIOBIOLOGICAL RESPONSES OF PLANTS*

Biological factors	Radiological factors
Cytological and genetic	Kinds of radiation(s)
Chromosome number	Energy or LET of radiation
Chromosome volume	Exposure fractionation
DNA content per chromosome	and previous exposures
Heterochromatin (amount of)	Exposure rate
Genotype or taxonomic group	Exposure duration
Length of mitotic cycle	Depth dose
Percentage of cells dividing	Location of radioisotope
Stage of nuclear cycle	Shielding (various)
(especially in meiosis)	Relative humidity
Morphological organization and	Moisture content of soil and
development	plants
Type of cell or tissue	Density of soil
Stage of differentiation (e.g.,	Chemical composition of
vegetative or floral)	plants and soil (for neutrons)
Portion(s) of plant irradiated	Distance from detonation
Size of plant or depth of	Time after detonation
sensitive organs	
Physiological or biochemical	Environmental factors
Age of plant	Temperature
Metabolic rate	Wind velocity
Stage of growth cycle	Dust or fallout (amount
(active or dormant)	and particle size)
pH of cells (and soil)	Moisture content of air,
Nutritional state	soil, and plants
Concentration of growth	Insects or other pests
hormones	Competition (other plants)
Concentration of protective	Season (day length, etc.)
or sensitizing substances	Available sunlight
	Soil fertility

*Modified from Gunckel and Sparrow.⁸

modifying effect of a few of the more important ones that might apply in an actual fallout situation. These, along with the accumulated effect of all the factors acting in the same direction, are given in Table 2. Of course, the probability that all these factors would simultaneously act in the same direction is remote. However, the exercise clearly emphasizes why we cannot assign an absolute sensitivity value to a given crop or species unless most of the radiological, biological, and environmental conditions are clearly stated.

Table 2

MAJOR FACTORS THAT DETERMINE OR MODIFY RADIOSENSITIVITY OF PLANTS AND EXTENT OF EFFECT PRODUCED BY EACH FACTOR WHEN ALONE AND WHEN CUMULATED WITH ALL OTHER FACTORS (ASSUMING THEM TO BE CUMULATIVE)

Factor	Change that increases effect	Maximum (or estimated) effect	Maximum cumulative interaction
Species (chromosome size*) ^{1 6}	Larger ICV	100	100
Stage or age†	Various	50	5,000
Environmental	Various	5‡	25,000
Exposure rate ^{4 4}	Higher rates	4	100,000
$\beta + \gamma$ interaction	Combination	2‡	200,000
RBE ^{9 0}	More densely ionizing radiation	20	4,000,000

*ICV (interphase chromosome volume).

†See Table 4.

‡Estimates considered to be conservative.

Table 3

RATIOS OF LD₅₀ VALUES* FOR VARIOUS EXPOSURE TIMES WITH CONSTANT-RATE, FDS, AND BU + FDS EXPOSURES (THE 16-HR LD₅₀ BEING GIVEN AN ARBITRARY VALUE OF 1.00)

Exposure time, hr	Treatment		
	Constant rate	Fallout decay simulation	Buildup + FDS
36	0.76†	1.40	1.41
16	1.00		
8	1.40		
4	2.00		
1	2.70		

*Based on data from lettuce irradiations^{3 7} except where noted.

†Based on data from squash, cabbage, pea, and maize irradiations.^{3 9, 5 1}

Influence of Exposure Rate and Duration

Exposure rate and duration are major variables which, under many conditions, modify the extent of injury produced by a given amount of radiation. Though studies done on the same species with different rates of exposure are desirable, they are not often made. However, as shown in Table 3, a

given exposure delivered at a higher rate (shorter exposure time) is more effective than the same exposure at a lower rate (longer exposure time). There are some limits to this effect, however. At very high exposure rates, further increases in rate may not bring about additional increases in effect,⁴⁵⁻⁴⁷ and at very low rates a point is reached where no external differences between irradiated and nonirradiated plants can be detected.^{18,48,49} This complete range in exposure-rate effects has recently been reported in one system.⁵⁰ Unfortunately current knowledge of exposure-rate effects is generally too inadequate to allow the application of mathematical models that would permit the prediction of effects at several different exposure rates from the results obtained at one exposure rate since the critical exposure rate may vary from species to species. For these reasons, the actual conditions of exposure for each experiment reported have been given when available since they do differ considerably.

Recent data show that for equal total exposures a 36-hr fallout-decay-simulation (FDS) treatment with decreasing exposure rates is more effective in reducing survival and yield than the previously used standard 16-hr constant-rate (CR) treatment.^{39,45,51} The average ratio of 16-hr CR to FDS treatment for several crop species at the LD₅₀ exposure is 1.4 (Table 3). The greater effectiveness of the FDS treatment is due to the very high initial exposure rates encountered with this type of exposure.⁴⁵ For yield reduction the FDS is more effective only at the higher exposures. It has been shown also that there was no significant difference between equal total exposures of an FDS treatment and an 8-hr CR treatment.⁴⁵ This is attributable to the fact that there is very little difference between the average exposure rate for an FDS treatment and the exposure rate for an 8-hr CR treatment. With exposure times less than 8 hr, the effectiveness of a given exposure increases with decreasing time (Table 3; see also Tables 8, 9, and 12).

Influence of Age and Stage Irradiated

It is well known that the age of a plant or its stage of differentiation or development can have a major influence on the amount of radiation required to produce a common end point.⁵²⁻⁶² The significance of stage of development at the time of irradiation is clearly indicated in Table 4, which gives data for sensitivity of various stages of development of the corn plant. The data presented indicate that the difference between the most sensitive stage (meiosis) and the most resistant stage (dry seed) exceeds 50-fold. Fortunately in most plant species the highly sensitive stage of meiosis is a fairly short one, lasting at most a few days. The high radiosensitivity of pollen may be important, especially since all of the most important cereal crops are wind pollinated. Because of their small size, most pollen grains would be vulnerable to injury from beta radiation both on the plant and in the air. Since the beta dose might exceed the gamma dose in most fallout situations, the total effect on pollen

Table 4
RADIOSENSITIVITY OF VARIOUS DEVELOPMENTAL
STAGES OF MAIZE (*ZEA MAYS*)

Stage	End point	Exposure, kR	Duration and type of exposure
Dry seed ^{9 1}			
10.6% moisture	LD ₅₀ (survival at 20 days)	54	2.7 kR/min gamma
1.9% moisture		10	2.7 kR/min gamma
Young plants	50% reduction in seed yield†	1	50 R/min gamma
	LD ₅₀ (at maturity) ^{5 1}	5.1	16 hr acute gamma
	LD ₁₀₀ (at maturity) ^{5 1}	6.5	16 hr acute gamma
	10% reduction in seed yield ^{5 1}	1	16 hr acute gamma
	50% reduction in seed yield ^{5 1}	4.3	16 hr acute gamma
	100% reduction in seed yield ^{5 1}	6	16 hr acute gamma
Meiosis	43% reduction in fresh weight of offspring†	1*	50 R/min gamma
Pollen (mature)	LD ₅₀ for flowers producing seed ^{9 2}	1.2	1.2 kR/min gamma

*Varies with stage of meiosis. Meiotic prophase is very sensitive but is of short duration.

†M. J. Constantin, UT-AEC Agricultural Research Laboratory, unpublished data, 1970.

could have a significant effect on yield, at least for the more sensitive species. This would also be true for very small seedlings or plant parts small enough for penetration by beta radiation.

The variation in sensitivity measured as reduced yield after irradiation at several stages during the growing period is given for five major crops in Fig. 4. The sensitivity for each crop can vary during the growing period from almost no effect to total loss of yield after identical exposures. Each crop has its own characteristic period of peak sensitivity, which varies from 6 days after emergence for soybeans to 195 days after emergence for winter barley. These data indicate not only the degree of variation in sensitivity with stage for a single species but also the variation among species. Not all these crops, however, would be expected to be at their stage of maximum sensitivity in a specific fallout situation. Differences in sensitivity with respect to yield of various economic plants irradiated at different stages of development are given in the section on deleterious effects on yield and survival of economic plants.

Influence of Postirradiation Time

Of considerable significance, particularly for economic plants, is the time after irradiation at which the radiation effects first become evident or first produce a serious effect. There are wide variations among species in the timing of specific responses to irradiation.^{6 3} Some plants show adverse effects or die

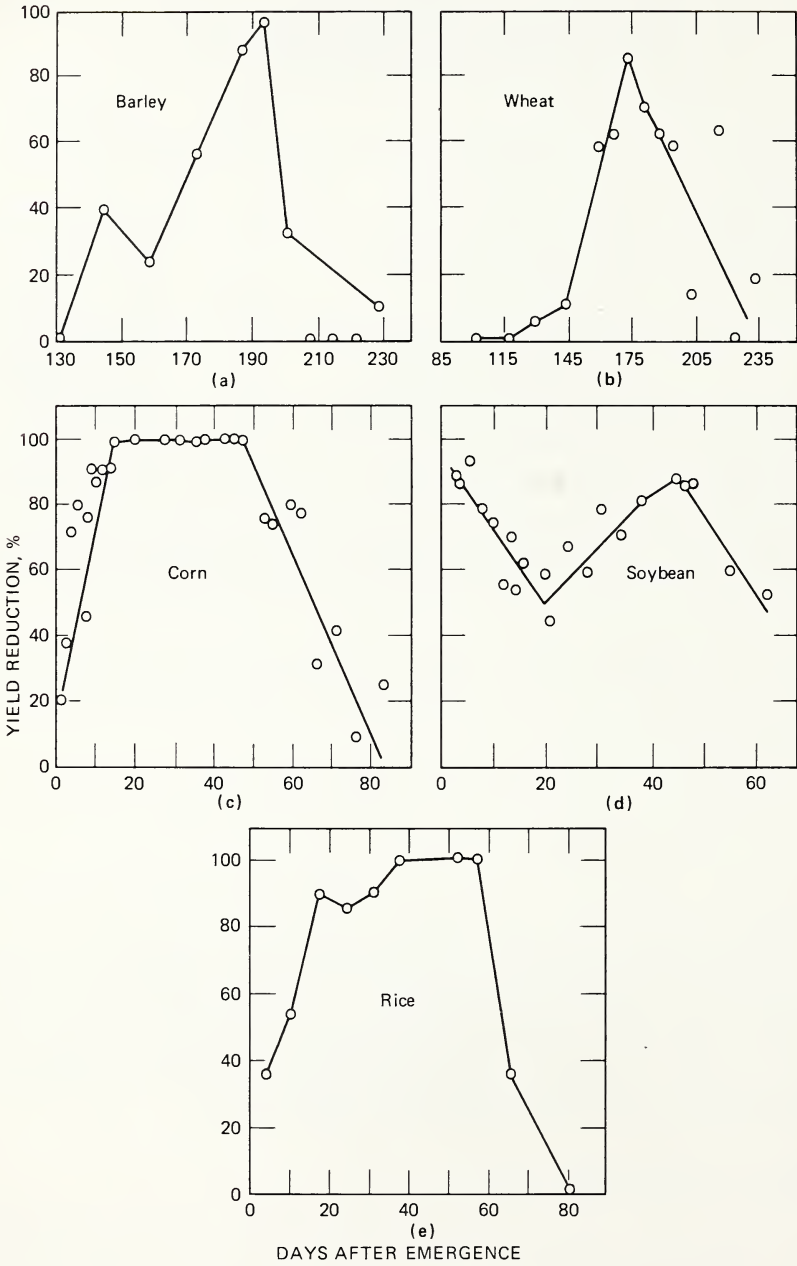

Figure 4

within a few days or at most a few weeks after irradiation, whereas others do not manifest such effects for many months, or even years for woody plants.¹¹ Results of experiments with tomato have shown that fruit production is considerably delayed by irradiation and the extent of delay increases with increasing exposure (Fig. 5). When the growing season is short, such a delay in production or ripening could essentially eliminate any useful harvest. Before the delayed effect becomes serious, however, some crop plants with a long latent period might be of value as forage crops.

Adverse effects on progeny from irradiated plants or seed also must be considered. Experiments done with a few species have shown that, depending on the stage of development at which the parent plant was irradiated (see previous discussion), the resultant yield from plants grown from seed of the parent crop may be seriously or moderately affected or not affected at all (see Table 5). Experiments with perennial plants, including various species of trees used as sources of lumber or edible fruits and nuts, have shown that deleterious effects may continue to manifest themselves years after the radiation treatment, particularly in the reproductive system.^{64,65}

Influence of Environmental Variables

The main environmental variables known to influence radiation-induced injury in plants are listed in Table 1. Except for dry-seed studies, very few experiments have been done testing the magnitude of effect produced by variation of one or more of these factors in concert with radiation treatment. However, some preliminary results are discussed here.

Lettuce plants given low exposures of radiation show considerably more stimulation of yield early in the growing season under conditions of longer day length than later in the season when the day is shorter.³⁷ Also, the effects ultimately manifested by perennial plants irradiated during different seasons (while the plants are active or dormant)^{12,66,67} or during different photoperiodic stages⁶⁸ may differ considerably. The effect of variations in light intensity and temperature on postirradiation survival of *Arabidopsis*, shown in



Fig. 4 Seed yield reduction of five crops after exposure to ⁶⁰Co gamma radiation at different days after seedling emergence. (a) 'Dayton' barley after exposure to 1 kR at 20 R/min. Maximum reduction was 95% at day 195. Plants irradiated before 130 days after emergence did not survive winter conditions. (b) 'Seneca' wheat after exposure to 1.6 kR at 20 R/min. Maximum reduction was 90% at day 175. Plants irradiated before 85 days after seedling emergence did not survive winter conditions. (c) Maize (WF-9X38-11) after exposure to 2.5 kR at 50 R/min. Maximum reduction was 100% at days 15 to 48. (d) 'Hill' soybeans⁹⁹ after exposure to 2.5 kR at 50 R/min. Maximum reduction was 90% at days 6 and 45. (e) Rice (CI 8970-S) after exposure to 25 kR at 50 R/min (redrawn from Siemer et al.⁶¹). Maximum reduction was 100% at days 37 to 57.

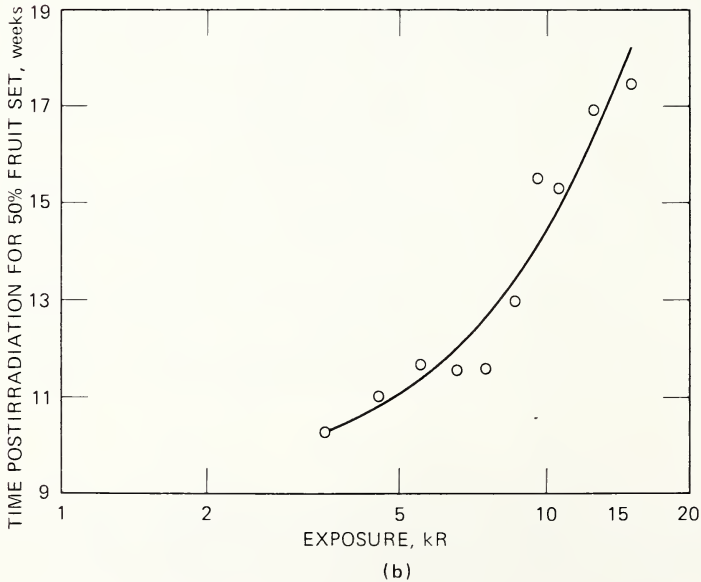
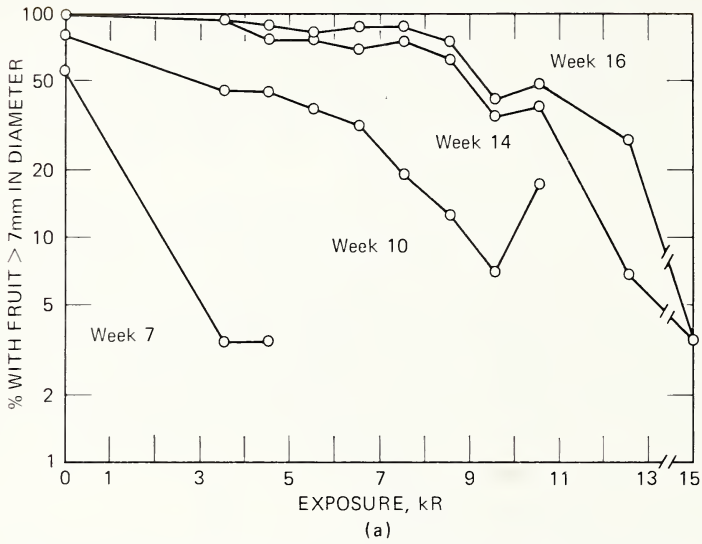

Fig. 5 Data from tomato plants given a 16-hr CR treatment. (a) Percent of plants with fruit vs. exposure at 7, 10, 14 and 16 weeks after irradiation. (b) Postirradiation time in weeks for 50% fruit set vs. exposure.⁵¹

Table 5
EFFECTS ON YIELD OF THE SUBSEQUENT CROP OF ACUTE GAMMA
IRRADIATION DELIVERED AT VARIOUS STAGES OF GROWTH TO
SPRING WHEAT, SPRING BARLEY, AND POTATOES^{9,3}

Stage of growth of parent crop when irradiated	Dose, rads	Yield of crop, % of control			
		Grain of spring wheat*		Grain of spring barley*	
		Parent crop	Subsequent crop	Parent crop	Subsequent crop
Two leaf	250	115	93	105	96
	500	97	97	61	103
	1000	68	98	†	
Four leaf	250	98	101	90	101
	500	95	101	50	105
	1000	62	102	†	
Ear emergence	250	86	82	87	96
	500	83	89	59	89
	1000	48	71		
Anthesis	500	91	87	84	86
	1000	73	62	76	47
Postanthesis	500	114	92	85	88
	2000	85	45	89	13
		Potato tubers [‡]			
		Parent crop	Subsequent crop		
Shoot emergence	2000		51	98	
	4000		15	66	
Stolon formation	2000		74	81	
	4000		33	77	
Tuber initiation	2000		78	96	
	4000		75	54	
	8000		55	†	

*Yield of parent crop figured in grams per plant; yield of subsequent crop in grams per square meter.

†Plants died before maturity.

‡Yield of both crops figured in grams per plant.

Fig. 6, demonstrates that increased temperature is synergistic with radiation treatment in producing deleterious effects.^{6,3} Competition or stress among plants is also known to be a factor in the eventual total effect exhibited by irradiated plants,^{6,9-7,3} as well as combined effects evident in ecosystem analysis.^{1,8} The maximum difference in effect (a factor of 5) given in Table 2 is considered to be a conservative estimate and may be exceeded in some cases.

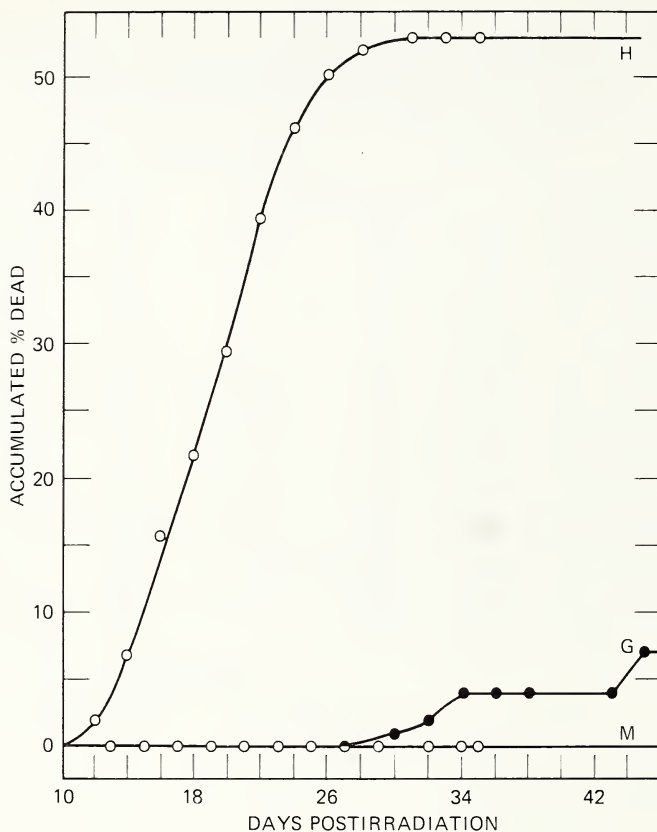

Fig. 6 Relation between accumulated percent dead and number of days postirradiation for plants of *Arabidopsis thaliana* receiving a 16-hr acute gamma exposure to 25 kR and grown under three different sets of conditions of temperature and light: H, 83 to 87°F, full light; G, 68 to 73°F, natural + supplemental light; and M, 68 to 72°F, two-thirds light. Plants were irradiated 13 to 15 days after germination.^{6,3} Maximum percent dead: H, 53%; G, 7%; M, 0%.

DELETERIOUS EFFECTS ON YIELD AND SURVIVAL OF ECONOMIC PLANTS

Although there is a large amount of general information concerning the radiobiological responses of higher plants, there are relatively few published data on deleterious effects on crop yield. The pertinent data available at present are summarized in this section.

Irradiation of Seed Grain, Seed Potato Tubers, Onion Transplants, Bulbs, etc.

The amount of data available for assessing second-generation effects on grain yield from irradiated grain is quite small, though much information exists for other criteria of effect. Radiosensitivities for dry seed of 30 plants of economic value are given in Table 6.⁷⁴ However, certain crops not listed, such as peas,

Table 6
LD₅₀ (kR) VALUES FOR 30 PLANTS OF ECONOMIC VALUE
AFTER ⁶⁰Co GAMMA IRRADIATION OF DRY SEED*

Common name	Scientific name	Dose rate, R/min	LD ₅₀ , kR
Alfalfa	<i>Medicago sativa</i>	844	38 to 62
Barley	<i>Hordeum vulgare</i>	844 to 850	13 to 20
Clover, button	<i>Medicago orbiculatus</i>	844	21
Clover, crimson	<i>Trifolium incarnatum</i>	844 to 1240	25 to >64
Clover, red	<i>Trifolium pratense</i>	795 to 1270	35 to >108
Clover, sweet	<i>Melilotus species</i>	844	59
Cowpea	<i>Vigna sinensis</i>	1260	11
Dallis grass	<i>Paspalum dilatatum</i>	710	> 32
Fescue	<i>Festuca elatior</i>	844	19
Grape	<i>Vitis species</i>	790 to 1240	<4 to <5
Guava	<i>Psidium guajava</i>	1240	17
Lespedeza, Korean	<i>Lespedeza stipulacea</i>	795	<40
Lupine, blue	<i>Lupinus angustifolius</i>	750	>40
Maize	<i>Zea mays</i>	840	> 15
Millet, German	<i>Setaria italica</i>	760	14
Oats	<i>Avena sativa</i>	840	17 to 27
Orchard grass	<i>Dactylis glomerata</i>	844	11
Papaya	<i>Carica papaya</i>	650	12
Peanut	<i>Arachis hypogea</i>	1260	10
Pepper	<i>Capsicum frutescens</i>	1260	24
Pigeon pea	<i>Cajanus cajan</i>	1260	15
Rice	<i>Oryza sativa</i>	650 to 1260	<15 to 42
Rye	<i>Secale cereale</i>	714 to 840	8 to 16
Sericea	<i>Lespedeza cuneata</i>	795 to 840	37 to 46
Sorghum, grain	<i>Sorghum vulgare</i>	1260	>40
Soybean	<i>Glycine max</i>	1260	11
Tomato	<i>Lycopersicon esculentum</i>	609 to 1240	13 to 37
Vetch, hairy	<i>Vicia villosa</i>	840	17
Watermelon	<i>Citrullus vulgaris</i>	1280	60
Wheat	<i>Triticum vulgare</i>	670 to 840	14 to 25

*Modified from Osborne and Lunden.⁷⁴

broad beans, and onions, are much more sensitive than those listed. In a very general way, seed radiosensitivity is related to plant radiosensitivity; i.e., rank order is similar, but actual exposures tolerated are quite different and are highly dependent on moisture content. The least effect on irradiated seeds of cereals is found at moisture contents of about 10 to 13%, and the seeds are more sensitive at moisture contents above or below this level.⁷⁵ Depending on the seed moisture content, variations in exposure rate can be as significant for seed irradiation as for irradiation of growing plants but are generally less significant. Seed radiosensitivity is also dependent on the oxygen effect,⁷⁶⁻⁷⁹ although this is an experimentally induced variable not generally applicable to seed under natural or agricultural conditions.

Exposure of seed potato tubers to 300 R before planting had no effect on yield; 1.2 kR brought about a moderate decrease, and 4.8 kR resulted in a negligible yield.⁸⁰ In an experiment using X rays, survival was reduced to 63% by an exposure of 4.0 kR.⁸¹ For small onion transplants an FDS exposure of 2.0 kR resulted in negligible bulb yield; 1.4 kR caused about a 50% reduction; and exposures of 1.1 kR or less produced very little effect on yield (see Table 10). In another study⁸² using higher exposure rates, 600 R reduced yield by 28% and 1.0 kR by 78%. Several ornamental bulbs are known to be highly sensitive or are predicted to be from ICV data. Predicted LD₅₀ values for FDS exposures are given in Table 7 for a number of species of horticultural interest.

Irradiation of Growing Plants

Because of the significance of stage of development and exposure times or rates on degree of injury produced, it was deemed necessary to specify these details in the summary tables. In many cases only one experiment was performed for a given crop at a specific stage, and in some cases the dosages chosen did not cover the most appropriate range. Also, in most cases the plants were irradiated under laboratory conditions and grown in a greenhouse or growth chamber. Almost no field irradiations have been made. The data on yield and survival have been subjected to computer analysis, which provided estimates (with errors) of the exposures required to reduce yield or survival by about 10, 50, or 90% of unirradiated control. We have used the terms YD₁₀, YD₅₀, or YD₉₀ as a shorthand method of specifying the exposure reducing the yield by 10, 50, or 90%, as is usually done for survival, i.e., LD₅₀, etc. It should be emphasized here that it is not only possible but even quite probable that gamma radiation exposures under actual fallout conditions might produce effects greater or less than those indicated in the summary tables (Tables 8 to 12). In other words, these tables can be used only as a general guide to anticipated effects. It is hoped that experiments planned or now under way will greatly improve the accuracy of these tables, at least for some crops. The effects of the beta component of fallout are considered elsewhere.⁸³ However, if a plant or plant

(Text continues on page 693.)

Table 7

PREDICTED RADIOSENSITIVITIES (36-HR FDS EXPOSURE) OF
25 SPECIES OF ECONOMICALLY IMPORTANT ORNAMENTAL
PLANTS GROWN FROM BULBS*

Common name	Scientific name	ICV, μ^3	Predicted $LD_{50} \pm S.D., kR$
Anemone, flame	<i>Anemone fulgens</i>	29.2	2.04 \pm 0.61
Belladonna lily	<i>Amaryllis belladonna</i>	56.5	1.05 \pm 0.31
Bluebell, Spanish	<i>Scilla hispanica</i>	54.8	1.08 \pm 0.32
Crocus	<i>Crocus</i> (average of 3 species)	60.8	0.98 \pm 0.29
Daffodil	<i>Narcissus pseudo-narcissus</i>	63.9	0.93 \pm 0.28
Fritillary, checkered	<i>Fritillaria meleagris</i>	91.6	0.65 \pm 0.19
Gladiolus	<i>Gladiolus</i> (average of 4 varieties)	4.7	12.66 \pm 3.78
Glory-of-the-snow	<i>Chionodoxa luciliae</i>	21.2	2.81 \pm 0.84
Grape hyacinth	<i>Muscari</i> (average of 2 species)	15.1	3.94 \pm 1.18
Hyacinth	<i>Hyacinthus</i> (average of 3 varieties)	56.2	1.06 \pm 0.32
Lily, Easter	<i>Lilium longiflorum</i>	52.2	1.14 \pm 0.34
Lily, Formosa	<i>Lilium formosanum</i>	66.6	0.89 \pm 0.27
Lily, regal	<i>Lilium regale</i>	65.4	0.91 \pm 0.27
Lily-of-the-valley	<i>Convallaria majalis</i>	32.0	1.86 \pm 0.56
Mariposa lily	<i>Calochortus</i> (average of 2 species)	27.7	2.15 \pm 0.64
Narcissus	<i>Narcissus</i> (average of 3 species)	39.6	1.50 \pm 0.45
Squill, Siberian	<i>Scilla sibirica</i>	82.9	0.72 \pm 0.21
Star-of-Bethlehem	<i>Ornithogalum virens</i>	52.8	1.12 \pm 0.34
Tigerflower	<i>Tigridia pavonia</i>	17.9	3.32 \pm 0.99
Torchlily	<i>Kniphofia uvaria</i>	71.2	0.84 \pm 0.25
Tritonia (montbretia)	<i>Tritonia crocata</i>	8.7	6.84 \pm 2.04
Tulip, Darwin	<i>Tulipa</i> species	59.8	0.99 \pm 0.30
Tulip, Foster (red emperor)	<i>Tulipa fosteriana</i>	55.5	1.07 \pm 0.32
Tulip, waterlily	<i>Tulipa kaufmanniana</i>	32.6	1.83 \pm 0.54
Zephyr lily	<i>Zephyranthes</i> species	72.9	0.82 \pm 0.24

*Used in the general sense, to include bulbs, corms, tubers, and rhizomes.

Table 8 SUMMARY OF RADIOSENSITIVITY DATA FOR CEREALS

Plant	Stage irradiated*	Type of exposure or exposure rate	End point used	Reduction from unirradiated control		
				YD _{1.0} or LD _{1.0} ± S.D., R	YD _{5.0} or LD _{5.0} ± S.D., R	YD _{9.0} or LD _{9.0} ± S.D., R
Spring barley, 'Manis Badger'	Two to four leaf†	30 R/min	Yield (seed weight)	310 ± 120	470 ± 97	890 ± 130
	Ear emergence†	30 R/min	Yield (seed weight)	130 ± 59	620 ± 45	1,950 ± 88
	Seedling‡	FDS	Survival	1580 ± 160	1,990 ± 77	2,400 ± 130
Spring barley, 'Mani'	Seedling‡	FDS	Yield (seed weight)	960 ± 310	1,370 ± 220	2,490 ± 340
	Seedling‡	8-hr CR	Survival	1740 ± 69	1,910 ± 43	2,200 ± 100
Maize, 'Golden Bantam'	Seedling‡	FDS	Survival	2960 ± 140	3,760 ± 85	4,560 ± 140
	Two leaf§	50 R/min	Yield (seed weight)	420 ± 360	800 ± 290	1,840 ± 310
Maize, WF-9X38-11 B37RF	Seedling‡	FDS	Survival	4060 ± 100	4,990 ± 80	5,920 ± 140
	Seedling‡	FDS	Yield (seed weight)	4220 ± 250	4,570 ± 190	5,540 ± 210
Spring oat, 'Condor'	Two to four leaf†	30 R/min	Yield (seed weight)	660 ± 220	920 ± 180	1,620 ± 210
	Ear emergence†	30 R/min	Yield (seed weight)	490 ± 110	2,210¶ ± 210	6,920¶ ± 830
	Anthesis†	30 R/min	Yield (seed weight)	420 ± 75	2,210 ± 130	7,090 ± 540
Spring oat, 'Orbit'	Seedling‡	FDS	Survival	2570 ± 160	3,420 ± 170	4,280 ± 290
	Seedling‡	FDS	Yield (seed weight)	1790 ± 30	1,950 ± 30	2,380 ± 20
Rice, CI-8970-S	Panicle emergence §	50 R/min	Yield (seed weight)	2270 ± 1000	14,300 ± 6500	47,200 ± 13,900
Spring wheat, 'Kloka'	Two to four leaf†	30 R/min	Yield (seed weight)	540 ± 46	1,410¶ ± 130	3,800 ± 480
	Ear emergence†	30 R/min	Yield (seed weight)	240 ± 72	900 ± 600	2,730 ± 170
	Anthesis†	30 R/min	Yield (seed weight)	400 ± 100	1,780 ± 140	5,580¶ ± 560
Spring wheat, 'Indus'	Seedling‡	FDS	Survival	2800 ± 110	3,090 ± 72	3,380 ± 110
	Seedling‡	8-hr CR	Survival	2900 ± 170	3,450 ± 110	4,000 ± 210
Winter wheat, 'Capelle'	Seedling‡	8-hr CR	Yield (seed weight)	1640 ± 330	2,060 ± 270	3,230 ± 410
	Ear emergence†	30 R/min	Yield (seed weight)	150 ± 44	860 ± 31	2,800¶ ± 74
	Anthesis†	30 R/min	Yield (seed weight)	320 ± 170	1,560 ± 160	4,980¶ ± 660

*Although meiotic stages are clearly the most sensitive, there is a general lack of data on these stages.

†Communicated by R. S. Russell, Agricultural Research Council, Letcombe Laboratory, England, 1970.

‡A. H. Sparrow and P. J. Bottino, Brookhaven National Laboratory, unpublished data, 1970.

§M. J. Constanin, UT-AEC Agricultural Research Laboratory, unpublished data, 1970.

¶Extrapolated well beyond data points.

Table 9 SUMMARY OF RADIOSENSITIVITY DATA FOR EDIBLE LEGUMES

Plant	Stage irradiated	Type of exposure or exposure rate*	End point	Reduction from unirradiated control		
				YD _{1,0} or LD _{1,0} ± S.D., R	YD _{5,0} or LD _{5,0} ± S.D., R	YD _{9,0} or LD _{9,0} ± S.D., R
Broad bean, 'Sutton'	Vegetative†	30 R/min	Yield (bean weight)	170 ± 84	220 ± 74	350 ± 73
	Flowering†	30 R/min	Yield (bean weight)	51 ± 29	110 ± 25	280 ± 23
Lima bean, 'Fordhook 242'	Seedling‡	FDS	Survival	5450 ± 120	6210 ± 80	6,980 ± 130
	Seedling‡	FDS	Yield (bean weight)	2000 ± 110	2390 ± 90	3,480 ± 50
	Flower bud‡	16-hr CR	Yield (bean weight)	420 ± 430	420 ± 430	2,020 ± 460
	Flower and pod‡	16-hr CR	Yield (bean weight)	670 ± 380	1460 ± 470	4,820 ± 560
	Pod‡	16-hr CR	Yield (bean weight)	4350 ± 20	6340 ± 20	11,790 ± 80
	Seedling‡	16-hr CR	Yield (whole plant weight)	3420 ± 450	4190 ± 360	6,280 ± 200
Pea, 'Alaska'	Seedling‡	16-hr CR	Yield (bean weight)	150 ± 50	920 ± 40	3,020 ± 30
	Seedling‡	FDS	Survival	1060 ± 170	2240 ± 71	3,430 ± 120
	Seedling‡	FDS	Yield (whole plant weight)	920 ± 100	1110 ± 88	1,630 ± 65
Pea, 'Meteor'	Seedling‡	FDS	Yield (pea weight)	800 ± 90	1010 ± 73	1,570 ± 59
	Vegetative†	30 R/min	Yield (pea weight)	380 ± 160	380 ± 160	1,060 ± 280
	Flowering†	30 R/min	Yield (pea weight)	250 ± 170	250 ± 170	600 ± 150
Soybean, 'Hill'	Early blooming§	50 R/min	Yield (bean weight)	550 ± 400	960 ± 350	2,070 ± 280
	Late blooming§	50 R/min	Yield (bean weight)	1160 ± 940	1940 ± 770	4,080 ± 770

*Yield data for other types of exposures are available for lima beans and peas.^{3,9,15,2}

†Communicated by R. S. Russell, Agricultural Research Council, Letcombe Laboratory, England, 1970.

‡A. H. Sparrow and P. J. Bottino, Brookhaven National Laboratory, unpublished data, 1970.

§M. J. Constanin, UT-AEC Agricultural Research Laboratory, unpublished data, 1970.

Table 10
SUMMARY OF RADIOSENSITIVITY DATA FOR ROOT CROPS

Plant	Stage irradiated	Type of exposure or exposure rate*	End point	Reduction from unirradiated control		
				YD _{1.0} or LD _{1.0} ± S.D., R	YD _{5.0} or LD _{5.0} ± S.D., R	YD _{9.0} or LD _{9.0} ± S.D., R
Garlic	Bulblets ^{9,4}	Acute	Survival	925 ± 265	1,120 ± 195	1,655 ± 300
Onion, 'Yellow Sweet Spanish'	Seedling†	FDS	Survival	1460 ± 57	1,890 ± 45	2,320 ± 86
	Seedling†	FDS	Yield (bulb weight)	1140 ± 74	1,360 ± 50	1,950 ± 76
Potato, 'Majestic'	Shoot emergence‡	80 R/min	Yield (tuber weight)	420 ± 390	1,660 ± 280	5,050 ± 590
	Stolon formation‡	80 R/min	Yield (tuber weight)	1080 ± 710	2,240 ± 590	5,420 ± 650
	Tuber initiation‡	80 R/min	Yield (tuber weight)	970 ± 580	9,330 ± 970	32,200 ± 4290
Radish, 'Cherry Belle'	Seedling†	FDS	Survival	9500 ± 800	12,900 ± 480	16,310 ± 870
	Seedling†	FDS	Yield (root weight)	6840 ± 580	8,870 ± 470	14,420 ± 360
Sugar Beet, 'Sharpes Klein E'	Initiation of swollen hypocotyl‡	80 R/min	Yield (root weight)	137 ± 1100	1,850 ± 3030	8,400 ± 3710
		80 R/min	Yield (sugar content)		1,400 ± 890	4,850 ± 790

*Yield data for other types of exposure are available for onion and radish.^{3,9,5,0}

†A. H. Sparrow and P. J. Bottino, Brookhaven National Laboratory, 1970.

‡Communicated by R. S. Russell, Agricultural Research Council, Letcombe Laboratory, England, 1970.

Table 11
SUMMARY OF RADIOSENSITIVITY DATA FOR MISCELLANEOUS FRUITS AND VEGETABLES

Plant	Stage irradiated	Type of exposure or exposure rate*	End point	Reduction from unirradiated control		
				YD _{1.0} or LD _{1.0} ± S.D., R	YD _{5.0} or LD _{5.0} ± S.D., R	YD _{9.0} or LD _{9.0} ± S.D., R
Cabbage, 'Ferry's Round Dutch'	Seedling†	FDS	Survival	8,550 ± 530	11,230 ± 300	13,900 ± 490
Lettuce, 'Summer Bibb'	Seedling	FDS	Survival	4,380 ± 80	4,790 ± 50	5,200 ± 80
	Seedling	FDS	Yield (whole plant)	4,310 ± 220	4,510 ± 180	5,040 ± 190
	Seedling	8-hr CR	Survival	4,590 ± 110	5,030 ± 70	5,460 ± 130
	Seedling	8-hr CR	Yield (whole plant)	3,340 ± 120	4,070 ± 70	6,070 ± 200
Pineapple, 'Smooth Cayenne'	Crown section ^{9,5}	Not given	Survival	5,510 ± 990	8,970 ± 850	18,440 ± 780
Spinach, 'Old Dominion'	Seedling	FDS	Survival	8,410 ± 490	11,800 ± 400	15,100 ± 660
Squash, 'Royal Acorn'	Seedling	FDS	Survival	4,170 ± 460	6,650 ± 300	9,140 ± 480
	Seedling	FDS	Yield (whole plant)	3,850 ± 190	6,400 ± 200	
Strawberry, 'Takane'	Stolon ^{9,6}	17 R/min	Yield (fruit weight)	1,330 ± 650	6,530 ± 1860	20,800 ± 7300
Tomato, 'Rutgers'	Seedling	16-hr CR	Survival	11,200 ± 460	13,300 ± 280	15,300 ± 440
	Seedling	16-hr CR	Yield (fruit weight)	10,100 ± 480	12,100 ± 290	17,600 ± 800

*Yield data for other types of exposures are available for cabbage, lettuce, and squash.^{3,9,5,0}

†A. H. Sparrow and P. J. Bottino, Brookhaven National Laboratory, 1970.

Table 12
SUMMARY OF RADIOSENSITIVITY DATA FOR PASTURE AND FORAGE CROPS

Plant	Stage irradiated	Type of exposure or exposure rate	End point	Reduction from unirradiated control		
				YD _{1.0} or LD _{1.0} ± S.D., R	YD _{5.0} or LD _{5.0} ± S.D., R	YD _{9.0} or LD _{9.0} ± S.D., R
Meadow fescue	3-week seedling*	30 R/min	Yield (whole plant)	3,030 ± 650	3,710 ± 580	5,570 ± 580
	7-week seedling*	30 R/min	Yield (whole plant)	1,500 ± 1070	2,480 ± 930	5,150 ± 1070
	3- + 7-week seedling*	30 R/min	Yield (whole plant)	2,830 ± 390	3,570 ± 350	5,580 ± 430
Perennial ryegrass	3-week seedling*	30 R/min	Yield (whole plant)		1,590 ± 1200	3,740 ± 1870
	7-week seedling*	30 R/min	Yield (whole plant)		1,930 ± 920	5,080 ± 2200
	3- + 7-week seedling*	30 R/min	Yield (whole plant)	1,090 ± 760	1,920 ± 590	4,170 ± 890
White clover	3-week seedling*	30 R/min	Yield (whole plant)	6,830 ± 1400	11,400 ± 1360	24,000† ± 3980
	7-week seedling*	30 R/min	Yield (whole plant)	6,450 ± 370	23,400 ± 970	69,900† ± 3930
	3- + 7-week seedling*	30 R/min	Yield (whole plant)	6,750 ± 2090	14,000 ± 2580	33,800† ± 9750
White clover, 'White Dutch'	Seedling‡	.16-hr CR	Survival	20,300 ± 740	24,200 ± 540	28,100 ± 970
Crested wheatgrass	Seedling ⁹ 7	300 R/min	Survival	1,490 ± 850	2000 ± 720	3400 ± 630

*Communicated by R. S. Russell, Agricultural Research Council, Letcombe Laboratory, England, 1970.

†Extrapolated well beyond data points.

‡A. H. Sparrow and P. J. Bottino, Brookhaven National Laboratory, unpublished data, 1970.

gamma radiation required to produce a specified effect will be reduced proportionately.

Herbaceous Species

Cereals (Table 8). Five of the most important cereal crops, which vary appreciably in sensitivity, were studied. For FDS or 8-hr CR exposures to young seedlings, YD_{50} values vary from about 1.4 kR for barley to 4.5 kR for maize, with intermediate values of about 2.0 kR for oats and about 2.1 kR for wheat. No FDS data are available for rice, but for several reasons, it can be expected to be appreciably more resistant than maize. As is generally true, the higher-exposure-rate (30 or 50 R/min) data mostly show greater damage for a given total exposure. For instance, YD_{50} values vary from about 500 to 600 R for barley to 2.2 kR for oats; wheat and maize are intermediate, and rice, by far the most resistant, has a YD_{50} of about 14 kR. At present no yield data exist for three other major cereal crops, namely, rye, sorghum, and pearl millet.

It is known that stage of development at time of exposure influences yield (see previous discussion). Barley and wheat at young-seedling stages are more sensitive than at later stages.^{53,54} However, data on lima beans,⁵² corn, and rice (Fig. 4) indicate that in these plants meiotic stages are considerably more sensitive than the seedling stage.

We should keep in mind that varietal differences are known to exist for several cereals.⁸⁴⁻⁸⁶ Differences are generally rather small, but in wheat varietal differences greater than fourfold have been demonstrated.⁸⁴

Legumes (Table 9). So far four different edible legumes (peas, broad beans, lima beans, and soybeans) have been irradiated, and all are highly sensitive or have highly sensitive stages. The YD_{50} for seed yield after FDS seedling irradiation varies from about 1.0 kR for peas to about 3.3 kR for lima beans and, after high-exposure-rate treatments, about 200 R for broad beans. Flower-bud stages are much more sensitive, as shown by both the pea and the lima-bean experiments in which YD_{50} values of approximately 250 and 110 R, respectively, were found following high-dose-rate exposures.

Root Crops (Table 10). The five root crops so far studied vary from an FDS YD_{50} of about 1.4 kR for onions to 8.9 kR for radishes. However, poor texture and bad taste were noted in radishes grown from seedlings irradiated at the higher exposures. Potatoes and sugar beets irradiated at 80 R/min as young plants have YD_{50} values of 1.66 kR and 1.85 kR, respectively. More data are needed for sugar beets since the standard error is large. We should note, however, that reduction in sugar content may be more susceptible to radiation than reduction in root weight, and, as shown in one study, sugar content decreases at a faster rate (R. S. Russell, personal communication), but the decrease does not occur under chronic irradiation.⁸⁷ Only survival data are available for garlic; however, the LD_{50} of 1.12 kR indicates that this species is fairly sensitive with regard to yield reduction.

Miscellaneous Fruit and Vegetable Crops (Table 11). Experiments have been conducted with cabbage, lettuce, pineapples, spinach, squash, and tomatoes, but only survival data are available for cabbage, pineapples, and spinach, which have LD₅₀ values of approximately 11.2 (FDS), 9.0, and 11.8 (FDS) kR, respectively. The tomato experiment is more difficult to summarize because the YD₅₀ was highly dependent on time after irradiation. However, at 10 weeks after exposure, the YD₅₀ was approximately 3 kR. Preliminary X-ray experiments with strawberries and raspberries irradiated in the dormant stage indicated only a mild effect on growth at a 16 kR exposure. No yield data were obtained (Sparrow, unpublished). Irradiation of strawberry stolons at 17 R/min produced a YD₅₀ of about 6.5 kR. The survival data available for pineapple indicate that crown sections are rather resistant to irradiation, having an LD₅₀ of about 9 kR. Limited data for irradiated sugarcane cuttings indicate an LD₅₀ of approximately 3 kR.^{8,8}

Pasture and Forage Crops (Table 12). Three grasses and two types of clover have been studied to date. Perennial rye has a YD₅₀ of about 1.6 kR and is about one-half as resistant as meadow fescue, which has a YD₅₀ of 3.7 kR. White clover, with a YD₅₀ of 24 kR, is much more resistant than the grass species at any stage examined. For sweet clover, however, a severe effect (80% reduction) on growth was observed at 4.0 kR after 16-hr acute exposures (Sparrow, unpublished). Only survival data are available for crested wheatgrass and this only at an exposure rate 10 times as high as for white clover and the two grasses.

Woody Species (Fruit, Nut, and Forest Trees, etc.)

Many of the more important forest trees, especially gymnosperms, are extremely sensitive to X or gamma radiation.^{9,11,12,26} Recently reported Soviet work has confirmed this high sensitivity by exposing trees to beta irradiation from a number of radionuclides using exposures extending over several years.^{8,9} Brookhaven work showed LD₅₀ values for a 16-hr exposure for

Table 13

LD₅₀ FOR FIVE SPECIES OF COMMON COMMERCIAL HARDWOODS¹¹

Common name	Species	LD ₅₀ ± S.D., R
Eastern red oak	<i>Quercus borealis</i> var. <i>maxima</i>	3650 ± 150
Yellow birch	<i>Betula lutea</i>	4280 ± 520
Sugar maple	<i>Acer saccharum</i>	4720 ± 150
Red maple	<i>Acer rubrum</i>	5110 ± 230
White ash	<i>Fraxinus americana</i>	7740 ± 260
	Average	5100 ± 700

a number of species to be less than 1.0 kR. Experiments with angiosperms (deciduous trees, including the fruit- and nut-producing trees) have shown them to be more resistant, with LD₅₀ values covering a much wider range. LD₅₀ data from these experiments are given in Tables 13 and 14 (see also Table 11).

Although all these values are based on actual experimental data, no absolute value of radiosensitivity can be given for any plant species growing under field conditions since a large number of variables influence the amount of injury finally produced by a given exposure. Of particular importance for these woody species is the changing radiosensitivity between the active and dormant stages,¹¹ the latter being more resistant by a factor of approximately 1.65.

Table 14
AVERAGE LD₅₀ FOR EIGHT GENERA (15 SPECIES)
OF GYMNOSPERMS¹¹

Genera	Number of species	Number of experiments	Range of LD ₅₀ , R	Average LD ₅₀ ± S.D., R
<i>Pseudotsuga</i>	1	1		461 ± 71
<i>Pinus</i>	3	3	473 to 818	692 ± 110
<i>Tsuga</i>	1	2	690 to 701	696 ± 6
<i>Picea</i>	4	6	626 to 1186	917 ± 91
<i>Larix</i>	2	2	705 to 834	770 ± 65
<i>Abies</i>	1	1		935 ± 26
<i>Taxus</i>	2	3	475 to 1203	939 ± 233
<i>Thuja</i>	1	1		970 ± 63
All genera	15	19	461 to 1203	826 ± 54

RELATION BETWEEN RADIOSENSITIVITY AND INTERPHASE CHROMOSOME VOLUME

As explained previously, the 36-hr FDS treatment appears to be a reasonable approximation of the exposure regime to which plants would be exposed during postattack fallout. The inverse relation between interphase chromosome volume (ICV) and radioresistance, also referred to previously, is applicable for a 36-hr FDS exposure as well as for shorter exposure times. The regression of ICV vs. LD₅₀ for young plants of species of economic value is given in Fig. 1. The regression slope is not significantly different from -1 at the 5% level of significance and is drawn as such. The regression of ICV vs. LD₁₀ also has a slope not significantly different from -1 (Fig. 2).

Postirradiation yield and survival data collected for many species of plants indicate a direct relation between LD₁₀ and YD₅₀ (see Fig. 7 and Table 15). When the data from economic crops only are plotted in this manner (Fig. 3), the

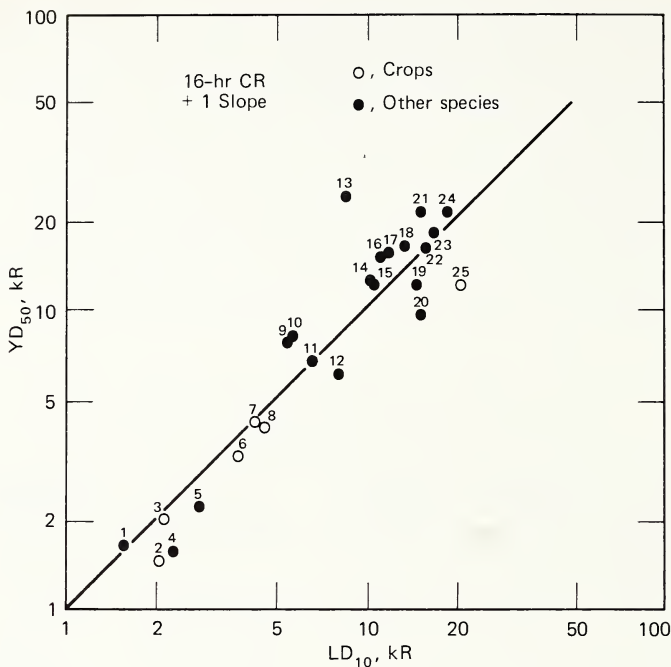

Fig. 7 Log-log regression of YD_{50} against LD_{10} for 25 species of plants given a 16-hr CR exposure as young plants. (See list of species names in Table 15.)

structure is small enough to allow penetration by beta radiation, the amount of regression also fits a +1 slope passing approximately through the origin (0.1, 0.1). Thus the determination of an LD_{10} for any species should provide a fair approximation of the expected YD_{50} .

Survival data were collected after 16-hr acute gamma irradiation for 28 species of woody plants, and LD_{50} values were determined. The regression for ICV vs. LD_{50} for these species (both angiosperms and gymnosperms), which has been published,¹¹ should be used for predictions for woody species since it is appreciably different from the regression for herbaceous plants.

RADIOSENSITIVITY PREDICTIONS (BASED ON ICV DATA)

The regressions described previously were used to predict from ICV measurements the probable sensitivities of many as yet unirradiated plant species.

Predicted YD_{50} values for FDS exposures are given for 89 species of economic crops (Tables 16 and 17). With the exception of rice (Group 7), the cereal crops are concentrated in the four most sensitive groups. Legumes are

Table 15

LIST OF 25 SPECIES OF PLANTS WITH THEIR YD_{50} AND LD_{10} VALUES FOR 16-HR ACUTE GAMMA IRRADIATIONS (AS IN FIG. 7)

No.	Species	YD_{50} , kR	LD_{10} , kR
1	<i>Haworthia fasciata</i>	1.65	1.57
2	<i>Pisum sativum</i>	1.45	2.03
3	<i>Hordeum vulgare</i>	1.80	2.16
4	<i>Aloe brevifolia</i>	1.55	2.27
5	<i>Nigella damascena</i>	2.20	2.79
6	<i>Triticum aestivum</i>	3.11	3.70
7	<i>Zea mays</i> (hybrid)	4.20	4.19
8	<i>Zea mays</i>	4.00	4.66
9	<i>Rumex orbiculatus</i>	7.80	5.38
10	<i>Cyanotis somaliensis</i>	8.35	5.64
11	<i>Chrysanthemum lacustre</i>	6.75	6.49
12	<i>Rumex hydrolapatium</i>	6.00	7.95
13	<i>Rumex stenophyllus</i>	24.10	8.32
14	<i>Rumex aquaticus</i>	12.80	10.32
15	<i>Rumex sanguineus</i>	12.40	10.46
16	<i>Rumex pulcher</i>	15.20	11.00
17	<i>Rumex obtusifolius</i>	15.30	11.59
18	<i>Rumex palustris</i>	16.40	13.04
19	<i>Rumex maritimus</i>	12.00	13.17
20	<i>Rumex confertus</i>	9.60	14.92
21	<i>Sedum rupifragum</i>	21.00	15.00
22	<i>Rumex conglomeratus</i>	16.00	16.04
23	<i>Rumex pseudonatronatus</i>	17.80	16.54
24	<i>Rumex crispus</i>	21.10	18.33
25	<i>Trifolium repens</i>	12.25	20.32

distributed over Groups 3 to 6. Root crops are scattered from Groups 2 to 7. Pasture or forage crops are widely distributed from Groups 3 to 8. Numerically, the majority of crop plants have estimated YD_{50} values between 4 and 16 kR. Only seven plants fall above 16 kR, and none of these is a major food crop. Also, the actual sensitivity of one of these (acorn squash) is considerably less than its predicted YD_{50} .⁵¹

Although few if any data are available on yield reduction for the fruit- and nut-producing trees, it would be expected, as found for herbaceous plants, that the YD_{50} would be appreciably less in each case than the LD_{50} . Predicted LD_{50} values for 16-hr acute exposures for 82 woody plants of economic value (for wood products or for edible fruit and nuts) are given in Table 18. These predictions are based on ICV's from actively growing trees. Trees irradiated while in the dormant stage are somewhat more resistant. However, FDS LD_{50} exposures would be expected to be somewhat less. These predictions are based

(Text continues on page 702.)

Table 16
 PREDICTED FALLOUT GAMMA EXPOSURE FOR 50% YIELD REDUCTION (YD_{50}) OF 89 ECONOMIC PLANTS*

Group 1, † <1 kR	Group 2, † 1 to 2 kR	Group 3, † 2 to 4 kR	Group 4, † 4 to 6 kR	Group 5, † 6 to 8 kR	Group 6, † 8 to 12 kR	Group 7, 12 to 16 kR	Group 8, 16 to 20 kR	Group 9, 20 to 24 kR	Group 10, >24 kR
Broad bean	Barley	Bean, lima	Alfalfa	Asparagus	Alfalfa (vernal)	Brussels sprouts	Bluestem, big	Squash,	Okra
Pea	Chives	Cucumber	Bean, kidney	Bluestem, little	Artichoke, globe	Dallis grass	Peppermint	winter	Rape,
	Garlic	Fescue, reed	Brome, smooth	Buckwheat	Bean, mung	Flax	Squash,	Squash,	winter
	Leek	Maize (hybrid)	Fescue, sheep	Cauliflower	Beet	Grama, blue	butternut	zucchini	
	Lentil	Oats	Hops	Celery	Broccoli	Mustard, India			
	Onion	Pea, field	Lettuce	Cotton	Cabbage,	Potato, sweet			
	Rye	Ryegrass,	Millet, pearl	Cowpea	Chinese	Rice			
		perennial	Orchard grass	Dill	Cantaloupe	Spearmint			
		Spinach,	Peanut	Kale	Carrot	Strawberry			
		round seed	Rhubarb	Muskmelon	Castor bean	Turnip			
		Wheat	Safflower	Parsnip	Glover, red				
		Wheatgrass,	Sorghum	Pepper, bush	Eggplant				
		bearded	Sunflower	Pepper, red (Bell)	Mustard, black				
		Wheatgrass,	Wheatgrass	Squash, acorn	Mustard, white				
		crested		Sugarcane	Parsley				
				Swiss chard	Radish				
				Timothy	Rape, bird				
				Tobacco, common	Rutabaga				
				Watermelon	Sesame, oriental				
					Sisal hemp				
					Soybean				

*Predictions are for young plants and are based on a regression of ICV vs. YD_{50} for seven species of economic plants given a 36-hr FDS exposure series.
 †Boldface type indicates these species for which actual FDS data are available. These data have been used to place the species in their appropriate groups.

Table 17 SCIENTIFIC AND COMMON NAMES FOR 89 ECONOMIC PLANTS
FOR WHICH YD_{50} PREDICTIONS HAVE BEEN MADE*

Scientific name	Common name†	Scientific name	Common name†
Group 1 (<1 kR)		Group 5 (6 to 8 kR) (continued)	
<i>Pisum sativum</i>	Pea	<i>Nicotiana tabacum</i>	Common tobacco
<i>Vicia faba</i>	Broad bean	<i>Pastinaca sativa</i>	Parsnip
Group 2 (1 to 2 kR)		<i>Pbleum pratense</i>	Timothy
<i>Allium cepa</i>	Onion	<i>Saccharum officinarum</i>	Sugarcane
<i>Allium porrum</i>	Leek	<i>Vigna sinensis</i>	Cowpea
<i>Allium sativum</i>	Garlic	Group 6 (8 to 12 kR)	
<i>Allium schoenoprasum</i>	Chives	<i>Agave rigida</i>	Sisal hemp
<i>Hordeum vulgare</i>	Barley	<i>Beta vulgaris</i>	Beet
<i>Lens culinaris</i>	Lentil	<i>Brassica campestris</i>	Bird rape
<i>Secale cereale</i>	Rye	<i>Brassica birta</i>	White mustard
Group 3 (2 to 4 kR)		<i>Brassica napobrassica</i>	Rutabaga
<i>Agropyron cristatum</i>	Crested wheatgrass	<i>Brassica nigra</i>	Black mustard
<i>Agropyron trachycaulum</i>	Bearded wheatgrass	<i>Brassica oleracea</i>	Broccoli
<i>Avena sativa</i>	Oats	<i>var. italica</i>	
<i>Cucumis sativus</i>	Cucumber	<i>Brassica pekinensis</i>	Chinese cabbage
<i>Festuca elatior</i>	Reed fescue	<i>Cucumis melo</i>	Cantaloupe
<i>Lolium perenne</i>	Perennial ryegrass	<i>var. cantalupensis</i>	
<i>Phaseolus limensis</i>	Lima bean	<i>Cynara scolymus</i>	Globe artichoke
<i>Pisum sativum arvense</i>	Field pea	<i>Daucus carota</i>	Carrot
<i>Spinacia oleracea</i>	Round seed spinach	<i>var. sativa</i>	
<i>Triticum aestivum</i>	Wheat	<i>Glycine max</i>	Soybean
<i>Zea mays</i>	Maize	<i>Medicago sativa</i>	Vernal alfalfa
Group 4 (4 to 6 kR)		<i>Petroselinum crispum</i>	Parsley
<i>Agropyron intermedium</i>	Wheatgrass	<i>Phaseolus aureus</i>	Mung bean
<i>Arachis hypogaea</i>	Peanut	<i>Rapbanus sativus</i>	Radish
<i>Bromus inermis</i>	Smooth brome	<i>Ricinus communis</i>	Castor bean
<i>Carthamus tinctorius</i>	Safflower	<i>Sesamum indicum</i>	Oriental sesame
<i>Dactylis glomerata</i>	Orchard grass	<i>Solanum melongena</i>	Eggplant
<i>Festuca ovina</i>	Sheep fescue	<i>Trifolium pratense</i>	Red clover
<i>Helianthus annuus</i>	Sunflower	Group 7 (12 to 16 kR)	
<i>Humulus lupulus</i>	Hops	<i>Bouteloua gracilis</i>	Blue grama
<i>Lactuca sativa</i>	Lettuce	<i>Brassica juncea</i>	Indian mustard
<i>Medicago sativa</i>	Alfalfa	<i>Brassica oleracea</i>	Brussels sprouts
<i>Pennisetum glaucum</i>	Pearl millet	<i>var. gemmifera</i>	
<i>Phaseolus vulgaris</i>	Kidney bean	<i>Brassica rapa</i>	Turnip
<i>Rheum rhabarbaricum</i>	Rhubarb	<i>Fragaria species</i>	Strawberry
<i>Sorghum vulgare</i>	Sorghum	<i>Ipomoea batatas</i>	Sweet potato
Group 5 (6 to 8 kR)		<i>Linum usitatissimum</i>	Flax
<i>Andropogon scoparius</i>	Little bluestem	<i>Mentha spicata</i>	Spearmint
<i>Anethum graveolens</i>	Dill	<i>Oryza sativa</i>	Rice
<i>Apium graveolens</i>	Celery	<i>Paspalum dilatatum</i>	Dallis grass
<i>Asparagus officinalis</i>	Asparagus	Group 8 (16 to 20 kR)	
<i>Beta cicla</i>	Swiss chard	<i>Andropogon gerardi</i>	Big bluestem
<i>Brassica oleracea</i>	Kale	<i>Cucurbita moschata</i>	Butternut squash
<i>var. acephala</i>		'Butternut'	
<i>Brassica oleracea</i>	Cauliflower	<i>Mentha piperita</i>	Peppermint
<i>var. botrytis</i>		Group 9 (20 to 24 kR)	
<i>Capsicum frutescens</i>	Bush red pepper (Bell)	<i>Cucurbita maxima</i>	Winter squash
<i>Citrullus vulgaris</i>	Watermelon	<i>Cucurbita pepo</i>	Zucchini squash
<i>Cucumis melo</i>	Muskmelon	<i>var. medullosa</i>	
<i>Cucurbita pepo</i>	Acorn squash	Group 10 (>24 kR)	
<i>Fagopyrum sagittatum</i>	Buckwheat	<i>Brassica napus</i>	Winter rape
<i>Gossypium hirsutum</i>	Cotton	<i>Hibiscus esculentus</i>	Okra

*See Table 16.

†Boldface type indicates those species for which actual FDS data are available. These data have been used to place the species in their appropriate groups.

Table 18
 PREDICTED 16-HR (ACUTE) GAMMA LD₅₀ EXPOSURES
 FOR 82 WOODY PLANTS OF ECONOMIC VALUE¹¹

Common name	Scientific name	LD ₅₀ ± S.D., kR
Almond	<i>Prunus amygdalus</i> Batsch 'Nonpareil'	3.11 ± 1.16
Apple, common	<i>Pyrus malus</i> L. 'Northern Spy'	4.60 ± 1.75
Apricot	<i>Prunus armeniaca</i> L. 'Blenheim'	3.00 ± 1.12
Arborvitae, eastern	<i>Tbujia occidentalis</i> L.	1.50 ± 0.55
Arborvitae, giant	<i>Tbujia plicata</i> Donn	1.70 ± 0.63
Ash, white	<i>Fraxinus americana</i> L.	7.11 ± 2.77
Aspen, quaking	<i>Populus tremuloides</i> Michx.	4.80 ± 1.83
Avocado, American	<i>Persea americana</i> Mill.	2.81 ± 1.05
Beech, American	<i>Fagus grandifolia</i> Ehrh.	6.41 ± 2.48
Birch, yellow	<i>Betula lutea</i> Michx. f.	6.63 ± 2.57
Blueberry, highbush	<i>Vaccinium corymbosum</i> L.	5.54 ± 2.13
Blueberry, lowbush	<i>Vaccinium angustifolium</i> Ait.	5.85 ± 2.25
Buckeye, yellow	<i>Aesculus octandra</i> Marsh.	7.11 ± 2.77
Cassava	<i>Manihot dulcis</i> Pax 'Valenca'	3.50 ± 1.32
Cedar, eastern red	<i>Juniperus virginiana</i> L.	1.35 ± 0.50
Cedar-of-Lebanon	<i>Cedrus libani</i> Loud.	0.84 ± 0.31
Cherry, mazzard	<i>Prunus avium</i> L. 'Windsor'	3.60 ± 1.36
Cherry, sour	<i>Prunus X cerasus</i> L.	5.85 ± 2.25
Chestnut, American	<i>Castanea dentata</i> (Marsh.) Borkh.	3.77 ± 1.42
Cranberry	<i>Vaccinium macrocarpon</i> Ait.	6.41 ± 2.48
Cryptomeria	<i>Cryptomeria japonica</i> D. Don 'Araucarioides'	1.22 ± 0.45
Cypress, bhutan	<i>Cupressus duclouxiana</i> Hickel	1.58 ± 0.58
Cypress, common bald	<i>Taxodium distichum</i> (L.) Rich.	1.71 ± 0.63
Eucalyptus, messmate stringy bark	<i>Eucalyptus obliqua</i> L' Her.	3.00 ± 1.12
Fig, common	<i>Ficus carica</i> L. 'Celeste'	6.21 ± 2.40
Fir, alpine	<i>Abies lasiocarpa</i> (Hook.) Nutt.	0.62 ± 0.23
Fir, balsam	<i>Abies balsamea</i> (L.) Mill.	0.75 ± 0.28
Fir, Douglas	<i>Pseudotsuga douglasii</i> Carr.	0.99 ± 0.37
Fir, grand	<i>Abies grandis</i> Lindl.	0.62 ± 0.23
Fir, white	<i>Abies concolor</i> Hoopes	0.81 ± 0.30
Grape	<i>Vitis</i> species 'Concord'	5.85 ± 2.25
Grape	<i>Vitis</i> species 'Delaware'	5.69 ± 2.19
Grapefruit	<i>Citrus paradisi</i> Macf.	3.27 ± 1.23
Hemlock, Canada	<i>Tsuga canadensis</i> (L.) Carr.	0.72 ± 0.27
Hemlock, Pacific	<i>Tsuga heterophylla</i> Sarg.	0.80 ± 0.30
Hickory, bitternut	<i>Carya cordiformis</i> (Wang.) K. Koch	7.69 ± 3.01
Hickory, mockernut	<i>Carya tomentosa</i> (Poir.) Nutt.	7.69 ± 3.01
Hickory, shagbark	<i>Carya ovata</i> (Mill.) K. Koch	6.03 ± 2.32
Hickory, shellbark	<i>Carya laciniata</i> (Michx. f.) Loud.	4.10 ± 1.55
Juniper, common	<i>Juniperus communis</i> L.	1.49 ± 0.55
Larch, eastern	<i>Larix laricina</i> (Duroi) K. Koch	0.69 ± 0.26
Larch, European	<i>Larix decidua</i> Mill.	0.77 ± 0.29
Larch, Japanese	<i>Larix leptolepis</i> Gord.	0.85 ± 0.31
Larch, western	<i>Larix occidentalis</i> Nutt.	0.85 ± 0.31

Table 18 (Continued)

Common name	Scientific name	LD ₅₀ ± S.D., kR
Lemon	<i>Citrus limonia</i> Burm. f. 'Villa Franca'	4.18 ± 1.58
Linden, American	<i>Tilia americana</i> L.	6.03 ± 2.32
Locust, black	<i>Robinia pseudoacacia</i> L.	3.15 ± 1.18
Maple, sugar	<i>Acer saccharum</i> Marsh.	4.80 ± 1.79
Oak, blackjack	<i>Quercus marilandica</i> Muenchh.	3.45 ± 1.30
Oak, eastern red	<i>Quercus borealis</i> Michx. f. var. <i>maxima</i> (Marsh.) Ashe	3.36 ± 1.26
Oak, post	<i>Quercus stellata</i> Wang.	3.96 ± 1.50
Oak, swamp chestnut	<i>Quercus prinus</i> L.	3.11 ± 1.16
Oak, white	<i>Quercus alba</i> L.	2.93 ± 1.10
Orange, mandarin	<i>Citrus reticulata</i> Blanco 'Cleopatra'	4.91 ± 1.87
Orange, sweet	<i>Citrus sinensis</i> Osbeck 'Parson Brown'	4.18 ± 1.58
Peach	<i>Prunus persica</i> (L.) Patsh.	4.60 ± 1.75
Pecan	<i>Carya illinoensis</i> (Wang.) K. Koch 'Sioux'	2.90 ± 1.08
Pine, Austrian	<i>Pinus nigra</i> Arnold	0.61 ± 0.23
Pine, eastern white	<i>Pinus strobus</i> L. 'Pendula'	0.52 ± 0.20
Pine, Himalayan	<i>Pinus griffithii</i> McClel.	0.50 ± 0.19
Pine, Japanese red	<i>Pinus densiflora</i> Sieg. et Zucc. 'Umbraculifera'	0.60 ± 0.22
Pine, loblolly	<i>Pinus taeda</i> L.	0.63 ± 0.23
Pine, ponderosa	<i>Pinus ponderosa</i> Dougl.	0.58 ± 0.22
Pine, pitch	<i>Pinus rigida</i> Mill.	0.67 ± 0.25
Pine, red	<i>Pinus resinosa</i> Ait.	0.70 ± 0.26
Pine, Scotch	<i>Pinus sylvestris</i> L.	0.62 ± 0.23
Pine, shore	<i>Pinus contorta</i> Loud.	0.70 ± 0.26
Pine, slash	<i>Pinus caribaea</i> Morelet	0.77 ± 0.29
Pine, sugar	<i>Pinus lambertiana</i> Dougl.	0.41 ± 0.16
Pine, Virginia	<i>Pinus virginiana</i> Mill.	0.69 ± 0.26
Plum, garden	<i>Prunus domestica</i> L.	4.60 ± 1.75
Redwood	<i>Sequoia sempervirens</i> Endl.	1.46 ± 0.54
Sequoia, giant	<i>Sequoiadendron giganteum</i> Buchholz	1.72 ± 0.64
Spruce, black	<i>Picea mariana</i> (Mill.) BSP.	0.84 ± 0.31
Spruce, Colorado	<i>Picea pungens</i> Engelm.	0.76 ± 0.28
Spruce, engelmann	<i>Picea engelmanni</i> Parry	0.73 ± 0.27
Spruce, Norway	<i>Picea abies</i> (L.) Karst.	0.73 ± 0.27
Spruce, red	<i>Picea rubens</i> Sarg.	0.57 ± 0.21
Spruce, white	<i>Picea glauca</i> (Moench) Voss	0.77 ± 0.29
Walnut, eastern black	<i>Juglans nigra</i> L.	3.83 ± 1.45
Walnut, Persian	<i>Juglans regia</i> L.	4.80 ± 1.83
Yew, Canada	<i>Taxus canadensis</i> Marsh.	0.99 ± 0.36

on the effective exposure dose actually received by the plants. Partial shielding by soil, water, or other plants, which has not been considered, could be important in certain instances.

Predicted values of LD_{50} (in kiloroentgens) for the dominant woody species in the major types of ecosystems are given in Table 19. A fallout gamma exposure of 1 to 2 kR would be expected to virtually eliminate the productive capacity of coniferous forests during a season of active growth and might seriously affect the natural balance of species in other forests and thus increase the possibility of secondary damage from fire, flood, and loss of nutrients.

It must be remembered that these predictions are made from regressions based on experiments handled under specific conditions. Any of a number of variables (see previous discussion of variables) can alter the predicted values in either direction and thus must be taken into account in planning experiments, evaluating radiobiological data, or assessing damage.

SUMMARY AND CONCLUSIONS

1. Problems are encountered in trying to anticipate the degree of damage to native or cultivated plants which would be produced by the radiation released by high-level fallout from nuclear detonations. Since almost no pertinent data resulting from such a disaster exist, it is necessary to extrapolate from other radiobotanical data. For short-term consideration of postattack damage, the gross radiation effects of greatest economic importance are reduced vegetative growth, reduced yield, and plant deaths. Alterations in normal plant tolerance to environmental stress also may occur, as may secondary effects resulting from the death of plants, such as loss of nutrients and increased probability of flood or fire damage. Although plants receiving postattack fallout would be exposed to both beta and gamma radiation, this report discusses mainly the results expected from the latter. Present data indicate an RBE of about 1 for these two radiations, but distribution and depth dose is a problem with beta radiation. The possibility of an interaction between the two types of radiation injury is very real and must be considered.

2. There is a wide range in radiosensitivities of plants determined or influenced by many biological, radiological, and environmental factors. Variation in exposure rate is an important factor, high rates being generally more effective (by a factor as great as 4) than low rates in reducing survival and yield. Variation in radiosensitivity among species exceeds a factor of 100. Within a species the stage of development of the plant may also affect its sensitivity by as much as a factor of 50; seeds are most resistant, and certain stages of meiosis are most sensitive (Table 4). Hence the seasonal timing of the exposure is an important variable.

3. Among the most important environmental conditions influencing the radiation response are temperature, light, and competition (Table 1). Experi-

PREDICTED SENSITIVITY TO GAMMA RADIATION OF MAJOR
WOODY ECOSYSTEMS AND THEIR DOMINANT PLANT SPECIES

Major ecosystem and vegetation type	Dominant species	Common name*	Predicted† 16-hr acute gamma LD ₅₀ ± S.D., kR
Coniferous Forests			
Boreal	<i>Abies balsamea</i>	Balsam fir	0.89 ± 0.03‡
	<i>Picea glauca</i>	White spruce	0.85 ± 0.05‡
Subalpine (Rocky Mts.)	<i>Abies lasiocarpa</i>	Alpine fir	0.62 ± 0.23
	<i>Picea engelmannii</i>	Engelmann spruce	0.73 ± 0.27
Montane (Rocky Mts.)	<i>Pinus ponderosa</i>	Ponderosa pine	0.58 ± 0.22
	<i>Pseudotsuga douglasii</i>	Douglas fir	0.99 ± 0.37
Sierra Cascades	<i>Abies concolor</i>	White fir	0.81 ± 0.30
	<i>Pinus jeffreyi</i>	Jeffrey pine	0.67 ± 0.25
	<i>Pinus lambertiana</i>	Sugar pine	0.41 ± 0.16
	<i>Pinus ponderosa</i>	Ponderosa pine	0.58 ± 0.22
Pacific conifer	<i>Pseudotsuga douglasii</i>	Douglas fir	0.46 ± 0.07‡
	<i>Abies grandis</i>	Grand fir	0.62 ± 0.23
	<i>Tbujia plicata</i>	Giant arborvitae	1.70 ± 0.63
	<i>Tsuga heterophylla</i>	Western hemlock	0.80 ± 0.30
Deciduous Forests			
Mixed mesophytic	<i>Acer saccharum</i>	Sugar maple	4.80 ± 1.79
	<i>Fagus grandifolia</i>	American beech	6.41 ± 2.48
	<i>Liriodendron tulipifera</i>	Yellow poplar	3.00 ± 1.12
	<i>Magnolia acuminata</i>	Cucumbertree magnolia	3.71 ± 1.40
	<i>Quercus alba</i>	White oak	2.93 ± 1.10
Beech—maple	<i>Tilia americana</i>	American linden	6.03 ± 2.32
	<i>Acer saccharum</i>	Sugar maple	4.80 ± 1.79
Maple—basswood	<i>Fagus grandifolia</i>	American beech	6.41 ± 2.48
	<i>Tilia americana</i>	American linden	6.03 ± 2.32
	<i>Tsuga canadensis</i>	Canada hemlock	0.72 ± 0.27
Hemlock— hardwood	<i>Acer saccharum</i>	Sugar maple	4.72 ± 0.15‡
	<i>Betula lutea</i>	Yellow birch	4.28 ± 0.52‡
	<i>Pinus resinosa</i>	Red pine	0.78 ± 0.03‡
	<i>Pinus strobus</i>	Eastern white pine	0.47 ± 0.01‡
Oak—chestnut	<i>Tsuga canadensis</i>	Canada hemlock	0.70 ± 0.05‡
	<i>Castanea dentata</i>	American chestnut	3.77 ± 1.42
	<i>Pinus rigida</i>	Pitch pine	0.67 ± 0.25
	<i>Quercus coccinea</i>	Scarlet oak	4.60 ± 1.75
Oak—hickory	<i>Quercus prinus</i>	Swamp oak	3.11 ± 1.16
	<i>Carya cordiformis</i>	Bitternut hickory	7.69 ± 3.01
	<i>Carya laciniata</i>	Shellbark hickory	4.10 ± 1.55
	<i>Carya ovata</i>	Shagbark hickory	6.03 ± 2.32
	<i>Carya tomentosa</i>	Mockernut hickory	7.69 ± 3.01
	<i>Pinus taeda</i>	Loblolly pine	0.63 ± 0.23
	<i>Quercus alba</i>	White oak	2.93 ± 1.10
	<i>Quercus borealis</i> var. <i>maxima</i>	Eastern red oak	3.36 ± 1.26
<i>Quercus marilandica</i>	Blackjack oak	3.45 ± 1.30	
<i>Quercus stellata</i>	Post oak	3.96 ± 1.50	
<i>Quercus velutina</i>	Black oak	5.02 ± 1.92	

*From *Standardized Plant Names*.^{9,8}

†Based on calculations of ICV from active meristems.

‡Observed mortality in actual experiments.^{1,1}

mental data suggest that these factors could cause the response to vary by as much as a factor of 10, excluding the effects of drought. Since significant exposures to radiation can be expected to delay flower initiation and ripening, plants with a growing season clearly limited by conditions of climate (e.g., tomato) might survive through the growing season but would produce essentially no useful yield. Also, since different species die at different rates after lethal irradiation, plants that die very quickly would be virtually worthless under postattack conditions, but those dying more slowly might be of some limited value.

4. The viability and vigor of seed from irradiated plants must be considered. The seed is used to produce the next crop, and adverse effects are sometimes present even in seed that superficially looks perfectly normal. Also, deleterious effects on growth or yield may be manifested in the subsequent crop (for annuals), and in some cases these effects appear several years after exposure (for perennials), especially in the reproductive processes.

5. It is useful to have a yield end point that can be compared for all crops, e.g., the exposure required to reduce yield by 50% (YD_{50}). Because seeds are generally relatively resistant compared with growing plants of the same species, they probably would not present a problem while in storage. The seedling LD_{50} for irradiated dry seeds is above 10 kR for most but not all crop plants (Table 6). Other propagules, such as seed potato tubers and small onion transplants, are more sensitive, having a YD_{50} value of about 1.5 kR.

6. A brief summary of existing sensitivity data on crop and other cultivated plants follows. (Keep in mind that modifying factors can have a large effect on response and there is no such thing as an absolute value under field conditions.) Most of the small grain cereals are relatively sensitive, having YD_{50} exposures that range from 0.5 to 5.0 kR (Table 8). Rice is an exception, having a YD_{50} of about 14.0 kR for young seedlings. Edible legumes vary more in sensitivity; exposures of 220 R to about 6.0 kR to vegetative stages produce a YD_{50} (Table 9). For flowering stages YD_{50} values range between about 100 and 400 R. The YD_{50} values for root crops vary from 1.4 kR for onions to about 9.0 kR for radishes; potatoes and sugar beets are intermediate in sensitivity (Table 10). The miscellaneous crops (in order of increasing resistance: lettuce, pineapple, strawberry, squash, spinach, cabbage, and tomato) have YD_{50} or LD_{10} values ranging from 4.5 to 12 kR (Table 11). The pasture and forage crop plants have a very wide range in sensitivity; YD_{50} or LD_{10} values range from about 1.5 to 23 kR (Table 12). Finally, some woody plants of economic importance are highly sensitive. The gymnosperms studied have an average LD_{50} value of 826 R (Table 14). The deciduous trees are somewhat more resistant, generally having LD_{50} values ranging from 3.6 to 7.7 kR (Table 13). The exposures seriously affecting their economic usefulness would be much lower.

7. The inverse relation between ICV and radioresistance holds for simulated-fallout-decay gamma exposures as reported previously for acute and chronic

gamma exposures. A regression of YD_{50} vs. LD_{10} has a slope not significantly different from +1 (Figs. 3 and 7). Thus an LD_{10} for any species can be used as a fair approximation of the YD_{50} . A table of YD_{50} predictions based on ICV is given for 89 species of economic plants showing the distribution of various crop plants over the entire range of sensitivity from less than 1 to more than 24 kR (Tables 16 and 17). Predictions of LD_{50} are also given for 25 species of ornamental plants (Table 7) and 82 species of woody plants (Table 18).

8. These predictions of survival and yield, although based on a large amount of experimental data, are for stated experimental conditions and average environmental conditions. They can be expected to vary considerably under actual fallout conditions and should not be considered absolute for any species. However, they should be useful in damage-assessment work because they give some advance indication of which crops might survive at various radiation levels and be available for human and/or animal consumption. For example, most small grain cereals (not including maize and rice) would be virtually useless where fallout gamma exposures exceed about 2.0 kR. Therefore only fields in fringe areas or away from the main fallout patterns would produce normal yields.

9. Finally, we should point out that the amount of radiobiological data is still highly inadequate to permit confident predictions of expected responses of many important species from high-level fallout-gamma exposure. This is especially true for yield and is even more critical if exposure occurs during meiosis or development of reproductive structures. Inadequate information about beta-radiation injury and possible interaction or synergism between beta and gamma radiation further complicates the problem. Clearly a much greater research effort is needed to fill the gaps in our radiobiological knowledge of economically important plant species. (See also the recommendations of the various working groups of this symposium, especially those concerned with the vulnerability of crops to beta and gamma radiation.^{100,101})

ACKNOWLEDGMENTS

This research was carried out at Brookhaven National Laboratory under the auspices of the U. S. Atomic Energy Commission.

We wish to thank J. Bryant, Brenda Floyd, E. E. Klug, Anne F. Nauman, Virginia Pond, Leanne Puglielli, L. A. Schairer, and Pamela Silimperi for technical assistance and K. H. Thompson for statistical analyses.

We gratefully acknowledge the use of unpublished data from several sources. These data are acknowledged in the appropriate tables. Recognition of the need for this review resulted from discussions at previous conferences sponsored by the Office of Civil Defense.

REFERENCES

1. J. P. Witherspoon and A. K. Corney, Differential and Combined Effects of Beta, Gamma and Fast Neutron Irradiation of Soybean Seedlings, *Radiat. Bot.*, **10**: 429-435 (1970).
2. R. S. Bruce and R. S. Russell, Agricultural Aspects of Acute and Chronic Contamination Situations, in *Environmental Contamination by Radioactive Materials*, Seminar Proceedings, Vienna, 1969, pp. 79-89, International Atomic Energy Agency, Vienna, 1969 (STI/PUB/226).
3. S. A. Griffin and G. R. Eisele, Problems in Postattack Livestock Salvage, this volume.
4. Y. C. Ng and H. A. Tewes, Radionuclide Body Burdens and Hazards from Ingestion of Foodstuffs Contaminated by Fallout, this volume.
5. R. S. Russell (Ed.), *Radioactivity and Human Diet*, Pergamon Press, Inc., New York, 1966.
6. R. S. Russell, B. O. Bartlett, and R. S. Bruce, The Significance of Long-Lived Nuclides After a Nuclear War, this volume.
7. J. E. Gunckel, Modifications of Plant Growth and Development Induced by Ionizing Radiations, in *Encyclopedia of Plant Physiology*, Vol. 15, Part 2, pp. 365-387, Springer-Verlag, Berlin, 1961.
8. J. E. Gunckel and A. H. Sparrow, Ionizing Radiations: Biochemical, Physiological and Morphological Aspects of Their Effects on Plants, in *Encyclopedia of Plant Physiology*, Vol. 16, pp. 555-611, Springer-Verlag, Berlin, 1961.
9. A. H. Sparrow, Research Uses of the Gamma Field and Related Radiation Facilities at Brookhaven National Laboratory, *Radiat. Bot.*, **6**: 377-405 (1966).
10. A. H. Sparrow, J. P. Binnington, and V. Pond, Bibliography on the Effects of Ionizing Radiations on Plants 1896-1955, USAEC Report BNL-504, Brookhaven National Laboratory, July 1958.
11. A. H. Sparrow, A. F. Rogers, and S. S. Schwemmer, Radiosensitivity Studies with Woody Plants. I. Acute Gamma Irradiation Survival Data for 28 Species and Predictions for 190 Species, *Radiat. Bot.*, **8**: 149-186 (1968).
12. A. H. Sparrow, S. S. Schwemmer, E. E. Klug, and L. Puglielli, Radiosensitivity Studies with Woody Plants. II. Survival Data for 13 Species Chronically Irradiated (up to 8 Years), *Radiat. Res.*, **44**: 154-177 (1970).
13. I. M. Vasil'ev, *Effect of Ionizing Radiations on Plants*, USAEC Report AEC-tr-5836, translated by Lydia Venters from Deistvie Ioniziruyushchikh Izlucheniina Rasteniyu, Izdatel'stvo Akademii Nauk SSSR, Moscow, 1962.
14. G. M. Woodwell and A. H. Sparrow, Effects of Ionizing Radiation on Ecological Systems, in *Ecological Effects of Nuclear War*, G. M. Woodwell (Ed.), USAEC Report BNL-917, pp. 20-38, Brookhaven National Laboratory, August 1965.
15. J. L. Brewbaker and G. C. Emery, Pollen Radiobotany, *Radiat. Bot.*, **1**: 101-154 (1962).
16. A. H. Sparrow, L. A. Schairer, and R. C. Sparrow, Relationship Between Nuclear Volumes, Chromosome Numbers and Relative Radiosensitivities, *Science*, **141**: 163-166 (1963).
17. G. M. Woodwell and J. K. Oosting, Effects of Chronic Gamma Irradiation on the Development of Old Field Plant Communities, *Radiat. Bot.*, **5**: 205-222 (1965).
18. G. M. Woodwell and A. H. Sparrow, Predicted and Observed Effects of Chronic Gamma Radiation on a Near-Climax Forest Ecosystem, *Radiat. Bot.*, **3**: 231-237 (1963).
19. K. Yamakawa and A. H. Sparrow, Correlation of Interphase Chromosome Volume and Reduction of Viable Seed Set by Chronic Irradiation of 21 Cultivated Plants During Reproductive Stages, *Radiat. Bot.*, **5**: 557-566 (1965).

20. K. Yamakawa and A. H. Sparrow, The Correlation of Interphase Chromosome Volume with Pollen Abortion Induced by Chronic Gamma Irradiation, *Radiat. Bot.*, **6**: 21–38 (1966).
21. A. H. Sparrow, Radiation Sensitivity of Cells During Mitotic and Meiotic Cycles with Emphasis on Possible Cytochemical Changes, *Ann. N. Y. Acad. Sci.*, **51**: 1508–1540 (1951).
22. A. H. Sparrow and V. Pond, Some Cytogenetic and Morphogenetic Effects of Ionizing Radiation on Plants, in *Proceedings of a Conference on Radioactive Isotopes in Agriculture*, Jan. 12–14, 1956, East Lansing, Mich., USAEC Report TID-7512, pp. 125–139, Argonne National Laboratory, January 1956.
23. N. Nybom, Some Further Experiments on Chronic Gamma Irradiation of Plants, *Botan. Notiser*, **109**: 1–11 (1956).
24. A. K. Sharma and A. K. Chatterji, Chromosome Size as a Factor in Radiosensitivity, *Nucleus (Calcutta)*, **5**: 67–74 (1962).
25. A. H. Sparrow, The Role of the Cell Nucleus in Determining Radiosensitivity, Brookhaven Lecture Series No. 17, USAEC Report BNL-766, Brookhaven National Laboratory, May 16, 1962.
26. A. H. Sparrow, Comparisons of the Tolerances of Higher Plant Species to Acute and Chronic Exposures of Ionizing Radiation, *Jap. J. Genet., Suppl.*, **40**: 12–37 (1965).
27. A. H. Sparrow, R. L. Cuany, J. P. Miksche, and L. A. Schairer, Some Factors Affecting the Responses of Plants to Acute and Chronic Radiation Exposures, *Radiat. Bot.*, **1**: 10–34 (1961).
28. A. H. Sparrow, R. C. Sparrow, K. H. Thompson, and L. A. Schairer, The Use of Nuclear and Chromosomal Variables in Determining and Predicting Radiosensitivities, *Radiat. Bot., Suppl.*, **5**: 101–132 (1965).
29. S. C. Sur, Interphase Chromosome Volume-Sensitivity Relationship in Some Diploid Annuals, *Technology (Sindri)*, **5**: 208–212 (1968).
30. S. A. Gordon, The Effects of Ionizing Radiation on Plants: Biochemical and Physiological Aspects, *Quart. Rev. Biol.*, **32**: 3–14 (1957).
31. International Atomic Energy Agency, Effects of Low Doses of Radiation on Crop Plants, Technical Report Series, No. 64, Vienna, 1966 (STI/DOC/10/64).
32. K. Sax, The Stimulation of Plant Growth by Ionizing Radiation, *Radiat. Bot.*, **3**: 179–186 (1963).
33. J. Skok, W. Chorney, and E. J. Rakosnik, Jr., An Examination of Stimulatory Effects of Ionizing Radiation in Plants, *Radiat. Bot.*, **5**: 281–292 (1965).
34. A. I. Grechushnikov, V. S. Serebrenikov and V. P. Kiryukhin, Effects of γ Radiation on Physio-Biochemical Modifications in Tubers and Plants, *Biokhim. Plodov i Ovoshech, Akad. Nauk SSSR, Inst. Biokhim.*, **2**: 191–201 (1964). (In Russian)
35. M. Jaarma, Influence of Ionizing Radiation on Potato Tubers, *Ark. Kem.*, **13**: 97–105 (1958).
36. C. E. O'Hara, The Effects of Gamma Irradiation on the Dehydrogenase Activities and on the Proteins of Irish Grown Wheats, *Radiat. Bot.*, **9**: 33–38 (1969).
37. P. J. Bottino, A. H. Sparrow, and B. Floyd, manuscript in preparation.
38. A. H. Sparrow and E. Christensen, Improved Storage Quality of Potato Tubers After Exposure to Co⁶⁰ Gammas, *Nucleonics*, **12**(8): 16–17 (1954).
39. A. H. Sparrow and L. Puglielli, Effects of Simulated Radioactive Fallout Decay on Growth and Yield of Cabbage, Maize, Peas and Radish, *Radiat. Bot.*, **9**: 77–92 (1969).
40. D. A. Banks and A. H. Sparrow, Effect of Acute Gamma Irradiation on the Incidence of Tumor-Like Structures and Adventitious Roots in Lettuce Plants, *Radiat. Bot.*, **9**: 21–26 (1969).

41. K. A. Madsen, D. K. Salunkhe, and M. Simon, Certain Morphological and Biochemical Changes in Gamma-Irradiated Carrots (*Daucus carota* L.) and Potatoes (*Solanum tuberosum* L.), *Radiat. Res.*, **10**: 48-62 (1959).
42. J. P. Skou, Notes on Hyperplasia Induced in Carrots by β -Rays, Decapitation or *Agrobacterium tumefaciens*, *Radiat. Bot.*, **9**: 397-406 (1969).
43. N. Nybom, The Use of Induced Mutations for the Improvement of Vegetatively Propagated Plants, in *Mutation and Plant Breeding*, pp. 252-294, National Academy of Sciences-National Research Council, Publication 891, Washington, D. C., 1961.
44. J. Schubert, Mutagenicity and Cytotoxicity of Irradiated Foods and Food Components, *Bull. World Health Organ.*, **41**: 873-904 (1969).
45. P. J. Bottino and A. H. Sparrow, Effects of Exposure Time and Rate on the Survival and Yield of Lettuce, Barley, and Wheat, this volume.
46. M. J. Constantin, D. D. Killion, and E. G. Siemer, Exposure-Rate Effects on Soybean Plant Responses to Gamma Irradiation, this volume.
47. G. J. McCrory and P. Grun, Relationship Between Radiation Dose Rate and Lethality of Diploid Clones of *Solanum*, *Radiat. Bot.*, **9**: 27-32 (1969).
48. J. M. Bostrack and A. H. Sparrow, The Radiosensitivity of Gymnosperms. II. On the Nature of Radiation Injury and Cause of Death of *Pinus rigida* and *P. strobus* After Chronic Gamma Irradiation, *Radiat. Bot.*, **10**: 131-143 (1970).
49. E. J. Hall and J. S. Bedford, A Comparison of the Effects of Acute and Protracted Gamma-Radiation on the Growth of Seedlings of *Vicia faba*. I. Experimental Observations, *Int. J. Radiat. Biol.*, **8**: 467-474 (1964).
50. J. S. Krebs and G. F. Leong, Effect of Exposure Rate on the Gastrointestinal LD₅₀ of Mice Exposed to ⁶⁰Co Gamma Rays or 250 kVp X-Rays, *Radiat. Res.*, **42**: 601-613 (1970).
51. A. H. Sparrow, B. Floyd, and P. J. Bottino, Effects of Simulated Radioactive Fallout Buildup and Decay on Survival and Yield of Lettuce, Maize, Radish, Squash, and Tomato, *Radiat. Bot.*, **10**: 445-455 (1970).
52. P. J. Bottino and A. H. Sparrow, Sensitivity of Lima Bean (*Phaseolus limensis* Macf.) Yield to ⁶⁰Co Gamma Radiation Given at Various Reproductive Stages, *Crop Sci.*, **11**: 436-437 (1971).
53. C. R. Davies, Effects of Gamma Irradiation on Growth and Yield of Agricultural Crops. I. Spring Sown Wheat, *Radiat. Bot.*, **8**: 17-30 (1968).
54. C. R. Davies, Effects of Gamma Irradiation on Growth and Yield of Agricultural Crops. II. Spring Sown Barley and Other Cereals, *Radiat. Bot.*, **10**: 19-27 (1970).
55. M. Devreux and F. Saccardo, Effets des radiations gamma sur les stades successifs de développement du gamétophyte mâle de tabac, *Radiat. Bot.*, **8**: 365-374 (1968).
56. M. Devreux and G. T. Scarascia Mugnozza, Effects of Gamma Radiation on the Gametes, Zygote and Proembryo in *Nicotiana tabacum* L., *Radiat. Bot.*, **4**: 373-386 (1964).
57. T. Hermelin, Effects of Acute Gamma Irradiation in Barley at Different Ontogenetic Stages, *Hereditas*, **57**: 297-302 (1967).
58. T. Kawai and T. Inoshita, Effects of Gamma Ray Irradiation on Growing Rice Plants. I. Irradiations at Four Main Developmental Stages, *Radiat. Bot.*, **5**: 233-255 (1965).
59. L. W. Mericle and R. P. Mericle, Radiosensitivity of the Developing Plant Embryo, in Fundamental Aspects of Radiosensitivity, Report of a Symposium, June 5-7, 1961, Upton, N. Y., USAEC Report BNL-675 (Brookhaven Symposia in Biology, Number 14), pp. 262-286, Brookhaven National Laboratory.
60. L. M. Monti and M. Devreux, Action des rayons gamma sur les gamètes, le zygote et le proembryon d'un pois fourrager, *Caryologia*, **17**: 433-441 (1964).

61. E. G. Siemer, M. J. Constantin, and D. D. Killion, Effects of Acute Gamma Irradiation on Development and Yield of Parent Plants and Performance of Their Offspring, this volume.
62. A. Yamashita, Effects of Acute and Chronic Gamma-Ray Irradiations on Growing Barley Plants, *Gamma Field Symp.*, 6: 71-95 (1967).
63. A. H. Sparrow and S. S. Schwemmer, The Effect of Postirradiation Temperature on Survival Times in Herbaceous Plants Exposed to Gamma Radiation, *Radiat. Res.*, 43: 227 (1970).
64. L. Decourtye, Stérilité, gamétique partielle provoquée par une irradiation gamma sur la variété de pommier Golden Delicious, *Radiat. Bot.*, 10: 1-5 (1970).
65. T. D. Rudolph, Effects of X-Irradiation of Seed on X_1 and X_2 Generations in *Pinus banksiana* Lambert, *Radiat. Bot.*, 7: 303-312 (1967).
66. A. H. Sparrow, L. A. Schairer, R. C. Sparrow, and W. F. Campbell, The Radiosensitivity of Gymnosperms. I. The Effect of Dormancy on the Response of *Pinus strobus* Seedlings to Acute Gamma Irradiation, *Radiat. Bot.*, 3: 169-173 (1963).
67. F. G. Taylor, Jr., Predicted Seasonal Radiosensitivity of Southeastern Tree Species, *Radiat. Bot.*, 6: 307-311 (1966).
68. G. N. Brown and F. G. Taylor, Interaction of Radiation and Photoperiodism in *Xanthium pensylvanicum*. Effects of Radiation During the Light and Dark Periods of Photoinduction, *Radiat. Bot.*, 7: 67-72 (1967).
69. G. M. Clark, F. Cheng, R. M. Roy, W. P. Sweaney, W. R. Bunting, and D. G. Baker, Effects of Thermal Stress and Simulated Fallout on Conifer Seeds, *Radiat. Bot.*, 7: 167-175 (1967).
70. J. F. McCormick, Changes in a Herbaceous Plant Community During a Three-Year Period Following Exposure to Ionizing Radiation Gradients, in *Radioecology*, Proceedings of the Symposium held Sept. 10-15, 1961, V. Schultz and A. W. Klement, Jr. (Eds.), pp. 271-276, Reinhold Publishing Corporation, New York, 1963.
71. J. F. McCormick and R. E. McJunkin, Interactions of Gamma Radiation and Other Environmental Stresses upon Pine Seeds and Seedlings, *Health Phys.*, 11: 1643-1652 (1965).
72. L. N. Miller, Changes in Radiosensitivity of Pine Seedlings Subjected to Water Stress During Chronic Gamma Irradiation, *Health Phys.*, 11: 1653-1662 (1965).
73. R. B. Platt, Ionizing Radiation and Homeostasis of Ecosystems, in *Ecological Effects of Nuclear War*, G. M. Woodwell (Ed.), USAEC Report BNL-917, pp. 39-60, Brookhaven National Laboratory, August 1965.
74. T. S. Osborne and A. O. Lunden, The Cooperative Plant and Seed Irradiation Program of the University of Tennessee, *Int. J. Appl. Radiat. Isotop.*, 10: 198-209 (1961).
75. R. A. Nilan, *The Cytology and Genetics of Barley, 1951-1962*, Washington State University Press, 1964.
76. A. Ehrenberg, L. Ehrenberg, and G. Löfroth, Radiation-Induced Paramagnetic Centers in Plant Seeds at Different Oxygen Concentrations, *Abb. Deut. Akad. Wiss. Berlin, Kl. Med.*, 1962(Nr.1): 229-231 (1962).
77. R. L. Latterell and D. M. Steffensen, The Oxygen Effect and Its Relation to Changes in Radiosensitivity During Seed Germination, *Mutat. Res.*, 4: 191-200 (1967).
78. R. A. Nilan, C. F. Konzak, R. R. Legault and J. R. Harle, The Oxygen Effect in Barley Seeds, in *Effects of Ionizing Radiations on Seeds*, Conference Proceedings, Karlsruhe, 1960, pp. 139-154, International Atomic Energy Agency, Vienna, 1961 (STI/PUB/13).
79. R. A. Nilan, C. F. Konzak, J. Wagner, and R. R. Legault, Effectiveness and Efficiency of Radiations for Inducing Genetic and Cytogenetic Changes, *Radiat. Bot., Suppl.*, 5: 71-89 (1965).

80. A. H. Sparrow and E. Christensen, The Effects of X-Ray, Neutron and Chronic Gamma Irradiation on Growth and Yield of Potatoes, *Amer. J. Bot.*, **37**: 667 (1950).
81. A. Heiken, Spontaneous and X-Ray-Induced Somatic Aberrations in *Solanum Tuberosum* L., *Acta Acad. Reg. Sci. Upsaliensis*, **7**: 1-125 (1960).
82. R. S. Kahan, Differential Effects of Small Doses of Ionizing Radiation on the Growth of Onion Seed and Bulblets and on Crop Yields, *Radiat. Bot.*, **9**: 175-178 (1969).
83. R. K. Schulz, Survival and Yield of Crop Plants Following Beta Irradiation, this volume.
84. B. Donini, G. T. Scarascia Mugnozza, and F. D'Amato, Effects of Chronic Gamma Irradiation in durum and Bread Wheats, *Radiat. Bot.*, **4**: 387-393 (1964).
85. M. Stoilov, G. Jansson, G. Eriksson, and L. Ehrenberg, Genetical and Physiological Causes of the Variation of Radiosensitivity in Barley and Maize, *Radiat. Bot.*, **6**: 457-467 (1966).
86. Y. Ukai, Studies on Varietal Differences in Radiosensitivity in Rice. III. Radiosensitivities with Respect to the Reduction in the Number of Dividing Cells and the Occurrence of Chromosome Bridges, *Jap. J. Breed.*, **18**: 221-228 (1968).
87. J. D. Spikes, Radiation Effects and Peaceful Uses of Atomic Energy in the Plant and Soil Sciences, in *Radioecology*, Proceedings of the Symposium held Sept. 10-15, 1961, V. Schultz and A. W. Klement, Jr. (Eds.), pp. 5-11, Reinhold Publishing Corporation, New York, 1963.
88. D. I. T. Walker and N. S. Sisodia, Induction of a Nonflowering Mutant in Sugarcane (*Saccharum* sp.), *Crop Sci.*, **9**: 551-552 (1969).
89. R. M. Alexakhin, R. T. Karaban, N. V. Kulikov, A. A. Molchanov, M. A. Naryschkin, S. V. Tarchevskaya, F. A. Tikhomirov, E. B. Tyuryukanova, and P. I. Yushkov, Some Aspects of Radioactive Fission Products Migration in the Forest Biogeocenoses and the Effects of Ionizing Radiations on the Woody Plants, in *Symposium International de Radioecologie*, Sept. 8-12, 1969, Cadarche, Report CONF-690918, Vol. 2, pp. 999-1023, Commissariat a l'Energie Atomique, 1970.
90. H. H. Smith, D. C. Joshua, N. C. Combatti, and K. H. Thompson, Relative Effects of Fission Neutron vs. X Irradiation of Seeds over a Wide Range of Genotypes, Doses and Moisture Levels, in *Symposium on Neutrons in Radiobiology*, USAEC Report CONF-691106, pp. 173-191, UT-AEC Agricultural Research Laboratory.
91. N. K. Notani and B. K. Gaur, Paradoxical Modifications in Radiosensitivity of Maize and Barley Seeds Stabilized for Different Moisture Contents, in *Biological Effects of Ionizing Radiation at the Molecular Level*, Symposium Proceedings, Brno, 1962, pp. 443-453, International Atomic Energy Agency, Vienna, 1962 (STI/PUB/60).
92. L. M. Josephson, data cited by T. S. Osborne and A. O. Lunden, The Cooperative Plant and Seed Irradiation Program of the University of Tennessee, *Int. J. Appl. Radiat. Isotop.*, **10**: 198-209 (1961).
93. C. R. Davies and S. F. Young, Effects of Irradiation of Parent Plants on Crop Yields, in Annual Report of Agricultural Research Council, Letcombe Laboratory, British Report ARCRL-20, pp. 12-15, 1969.
94. C. Y. Harn, J. K. Choi, and Y. S. Koh, Studies on Garlic Breeding Using Radiation. II. Morphological Effects on Gamma-Ray-Induced R_1 Generation in Garlic, *Allium sativum*, *J. Nucl. Sci. (Seoul)*, **8**: 121-125 (1968). (In Korean)
95. H. Irizarry and J. Vélez Fortuño, Effect of Gamma Radiation Dosages on Rooting of Pineapple Crown Sections, Shoot Emergence and Growth, *J. Agr. Univ. Puerto Rico*, **54**: 551-558 (1970).
96. S. Matsumura and T. Fujii, Radiosensitivity in Plants. II. Irradiation Experiments with Vegetatively Propagated Plants, *Seiken Zibō*, **10**: 22-32 (1959).
97. W. S. Boyle, Radioresistance of F_1 Hybrids in the Triticeae, *Radiat. Bot.*, **8**: 1-6 (1968).

98. American Joint Committee on Horticultural Nomenclature, *Standardized Plant Names*, 2nd ed., J. Horace McFarland Co., Harrisburg, Penn., 1942.
99. D. D. Killion and M. J. Constantin, Fallout Radiation and Crop Productivity. Part B, UT-AEC Agricultural Research Laboratory Annual Report, OCD Work Unit 3223B, 1969.
100. Report of Committee 2 on Vulnerability of Crops to Fallout Beta Irradiation, Appendix A, this volume.
101. Report of Committee 3 on Vulnerability of Crops to Fallout Gamma Irradiation, Appendix A, this volume.

LIST OF ATTENDEES

DONALD R. ADAMS
Health Service Laboratory
U. S. Atomic Energy Commission
Idaho Falls, Idaho

PAUL ALLEY
OCD Region Six
Federal Regional Center
Denver, Colo.

ARNA J. ANDERSON
105 Buck Jones Road
Raleigh, N. C.

CHARLES ANDERSON
Systems Sciences, Inc.
Bethesda, Md.

JOHN J. B. ANDERSON
College of Veterinary Medicine
University of Illinois
Urbana, Ill.

STANLEY I. AUERBACH
Ecological Sciences Division
Oak Ridge National Laboratory
Oak Ridge, Tenn.

H. JAMES BARTH
6456 Woodridge Road
Alexandria, Va.

NED D. BAYLEY
Director, Science and Education
U. S. Department of Agriculture
Office of the Secretary
Washington, D. C.

M. C. BELL
UT-AEC Agricultural Research
Laboratory
Oak Ridge, Tenn.

DAVID W. BENSEN
Postattack Research Division
Office of Civil Defense (OSA)
Washington, D. C.

VICTOR P. BOND
Associate Director
Brookhaven National Laboratory
Upton, Long Island, N. Y.

PAUL J. BOTTINO
Biology Department
Brookhaven National Laboratory
Upton, Long Island, N. Y.

CORNELIS BROERTJES
Institute for Atomic Sciences
in Agriculture
Wageningen, The Netherlands

STEPHEN L. BROWN
Stanford Research Institute
Menlo Park, Calif.

A. K. BURDITT, JR.
Agricultural Research Service
U. S. Department of Agriculture
Beltsville, Md.

J. A. J. CARRIERE
Animal Disease Research Institute
Canada Department of Agriculture
Hull, Que., Canada

ROBERT CHERTOK
Bio-Medical Division
Lawrence Radiation Laboratory
Livermore, Calif.

RICHARD COLE
Environmental Science Associates
Burlingame, Calif.

MILTON J. CONSTANTIN
UT-AEC Agricultural Research
Laboratory
Oak Ridge, Tenn.

A. H. CORNER
Head, Histopathology Section
Animal Disease Research Institute
Canada Department of Agriculture
Hull, Que., Canada

G. E. COSGROVE
Biology Division
Oak Ridge National Laboratory
Oak Ridge, Tenn.

WILLIAM T. COX
Extension Service
U. S. Department of Agriculture
Washington, D. C.

HARVEY L. CROMROY
University of Florida
Gainesville, Fla.

ROGER DAHLMAN
Ecological Sciences Division
Oak Ridge National Laboratory
Oak Ridge, Tenn.

JAMES A. DAVIS
Agricultural Stabilization and
Conservation Service
U. S. Department of Agriculture
Washington, D. C.

K. E. DIEHL
Animal Health Division
U. S. Department of Agriculture
Harrisburg, Pa.

DONATO DIGREGORIO
Ecological Sciences Division
Oak Ridge National Laboratory
Oak Ridge, Tenn.

PAUL DUNAWAY
Ecological Sciences Division
Oak Ridge National Laboratory
Oak Ridge, Tenn.

BRUCE M. EASTON
Agricultural Stabilization and
Conservation Service
U. S. Department of Agriculture
Washington, D. C.

RONALD E. ENGEL
National Air Pollution Control
Administration
Bureau of Criteria and Standards
Durham, N. C.

H. E. ERDMAN
Battelle-Northwest
Richland, Wash.

GEORGE F. FRIES
Animal Sciences Research Division
U. S. Department of Agriculture
Beltsville, Md.

JOHN F. GAMBLE
Environmental Engineering
University of Florida
Gainesville, Fla.

HAL GAUT
RADEF Officer
OCD Region Two
Olney, Md.

HELLMUT GLUBRECHT
Institut für Strahlenbiologie
Technische Universität Hannover
Hannover, West Germany

JACK C. GREENE
Postattack Research Division
Office of Civil Defense (OSA)
Washington, D. C.

SUMNER A. GRIFFIN
UT-AEC Agricultural Research
Laboratory
Oak Ridge, Tenn.

NATHAN S. HALL
UT-AEC Agricultural Research
Laboratory
Oak Ridge, Tenn.

R. L. HALSTEAD
Soil Research Institute
Canada Department of Agriculture
Ottawa, Ont., Canada

RICHARD I. C. HEDE
OCD Region One
Federal Regional Center
Maynard, Mass.

DAVID E. HEIMAN
OCD Region Seven
Santa Rosa, Calif.

A. HEKKING
3 Burke Heights Drive
Wallingford, Conn.

F. P. HUNGATE
Biology Department
Battelle-Northwest
Richland, Wash.

PAUL E. JAMES
Agricultural Research Service
U. S. Department of Agriculture
Beltsville, Md.

GORDON C. JANNEY
Agricultural Research Service
U. S. Department of Agriculture
Madison, Wis.

BILLY G. JOHNSON
Agricultural Research Service
U. S. Department of Agriculture
Hyattsville, Md.

JAMES E. JOHNSON
Department of Animal Science
Colorado State University
Fort Collins, Colo.

DAVID C. L. JONES
Stanford Research Institute
Menlo Park, Calif.

ERIC W. JONES
Box 22
Hazeldean, Ont., Canada

ASHER D. KANTZ
Santa Barbara Division
EG&G, Inc.
Goleta, Calif.

CHARLES KETCHAM
OCD Region Four
Federal Center
Battle Creek, Mich.

DONALD D. KILLION
UT-AEC Agricultural Research
Laboratory
Oak Ridge, Tenn.

WILLIAM KITTEL
Food and Drug Emergency
Preparedness
U. S. Department of Health,
Education, and Welfare
Rockville, Md.

JOHN S. KREBS
Stanford Research Institute
Menlo Park, Calif.

C. Z. KWAST
Agricultural Research Service
U. S. Department of Agriculture
Beltsville, Md.

GEORGE B. LANDERKIN
Food Research Institute
Canada Department of Agriculture
Ottawa, Ont., Canada

WILLIAM B. LANE
Stanford Research Institute
Menlo Park, Calif.

DARWIN LAPHAM
OCD Staff College
Federal Center
Battle Creek, Mich.

HOWARD F. LEHNERT, JR.
Agricultural Research Service
U. S. Department of Agriculture
Beltsville, Md.

EDWIN W. LINDQUIST, JR.
USAMEDD Veterinary School
Chicago, Ill.

ARVIN I. LOVAAS
Department of Animal Science
Colorado State University
Fort Collins, Colo.

JOHN McAULAY
20 Windermere Road
West Wickham
Bromley, Kent, England

W. D. McCLELLAN
Agricultural Research Service
U. S. Department of Agriculture
Beltsville, Md.

FRANK McCORMICK
Department of Botany
University of North Carolina
Chapel Hill, N. C.

J. MARTIN
Lawrence Radiation Laboratory
Livermore, Calif.

SAAD Z. MIKHAIL
Environmental Science Associates
Burlingame, Calif.

CARL F. MILLER
The Systems Operations Corporation
Hallock, Minn.

DONALD MILLER
Agricultural Research Service
U. S. Department of Agriculture
Hyattsville, Md.

K. B. MISTRY
Biology Division
Bhabha Atomic Research Centre
Trombay, Bombay, India

WILLIAM B. MORTON
Division of Communications and
Electronics
U. S. Forest Service
Washington, D. C.

ROBERT MULLEN
Santa Barbara Division
EG&G, Inc.
Goleta, Calif.

PETER G. MURPHY
Department of Botany
University of North Carolina
Chapel Hill, N. C.

- WILLIAM F. NAPE
Agricultural Research Service
U. S. Department of Agriculture
Springfield, Ill.
- W. T. L. NEAL
Ministry of Agriculture, Fisheries
and Food
London, England
- YOOK NG
Bio-Medical Division
Lawrence Radiation Laboratory
Livermore, Calif.
- JOHN H. NORMAN
Gulf General Atomic, Inc.
San Diego, Calif.
- WILLIAM S. OSBURN, JR.
Environmental Sciences Branch
Division of Biology and Medicine
U. S. Atomic Energy Commission
Washington, D. C.
- L. N. PETERS
Oak Ridge National Laboratory
Oak Ridge, Tenn.
- M. K. POMEROY
Cell Biology Research Institute
Canada Department of Agriculture
Ottawa, Ont., Canada
- GILBERT POTTER
Bio-Medical Division
Lawrence Radiation Laboratory
Livermore, Calif.
- H. L. RAGSDALE
Emory University
Atlanta, Ga.
- DAVID E. REICHLE
Ecological Sciences Division
Oak Ridge National Laboratory
Oak Ridge, Tenn.
- WILLIAM A. RHOADS
Santa Barbara Division
EG&G, Inc.
Goleta, Calif.
- E. M. ROMNEY
Laboratory of Nuclear Medicine
and Radiation Biology
University of California
Los Angeles, Calif.
- T. D. RUDOLPH
Institute of Forest Genetics
U. S. Forest Service
Rhinelander, Wis.
- R. SCOTT RUSSELL
Agricultural Research Council
Letcombe Laboratory
Wantage, Berkshire, England
- PAUL F. SAND
Agricultural Research Service
U. S. Department of Agriculture
Hyattsville, Md.
- LYLE B. SASSER
UT-AEC Agricultural Research
Laboratory
Oak Ridge, Tenn.
- A. M. SCHEIDT
Consumer and Marketing Service
U. S. Department of Agriculture
Denton, Tex.
- CLAUDE H. SCHMIDT
Agricultural Research Service
U. S. Department of Agriculture
Beltsville, Md.
- ROBERT K. SCHULZ
University of California
Berkeley, Calif.
- E. C. SHARMAN
Agricultural Research Service
U. S. Department of Agriculture
Washington, D. C.

EUGENE G. SIEMER
Colorado Department of Agriculture
Fort Collins, Colo.

ROBERT E. SIMPSON
Bureau of Foods
Food and Drug Administration
Washington, D. C.

J. F. SPALDING
Los Alamos Scientific Laboratory
University of California
Los Alamos, N. Mex.

ARNOLD H. SPARROW
Biology Department
Brookhaven National Laboratory
Upton, Long Island, N. Y.

MARLOW J. STANGLER
Chief, RADEF Branch, PO(EO)
Office of Civil Defense
Washington, D. C.

BURKE STANNARD
Defense Research Board
Defense Research Analysis
Establishment
National Defense Headquarters
Ottawa, Ont., Canada

VERNON M. STERN
University of California
Riverside, Calif.

E. STILL
Division of Biology and Medicine
U. S. Atomic Energy Commission
Washington, D. C.

WALMER E. STROPE
Office of Civil Defense (OSA)
Washington, D. C.

CLARENCE E. STYRON
Mathematics and Natural Science
Division
St. Andrews Presbyterian College
Laurinburg, N. C.

T. TANADA
Agricultural Research Service
U. S. Department of Agriculture
Beltsville, Md.

F. T. TAYLOR
Oak Ridge National Laboratory
Oak Ridge, Tenn.

MICHAEL TERPILAK
Division of Environmental Radiation
U. S. Public Health Service
Rockville, Md.

J. C. THOMPSON
Cornell University
Ithaca, N. Y.

KENNETH R. THOMPSON
Agricultural Research Service
U. S. Department of Agriculture
Jacksonville, Fla.

D. E. TORKELSON
Agricultural Research Service
U. S. Department of Agriculture
Austin, Tex.

JOSEPH W. TURELLE
275 Bryn Mawr Avenue
Bryn Mawr, Pa.

ROBERT VAN HOOK
Ecological Sciences Division
Oak Ridge National Laboratory
Oak Ridge, Tenn.

GEORGE H. WALTER
U. S. Department of Agriculture
Washington, D. C.

EDMUND G. WARNER
Agricultural Research Service
U. S. Department of Agriculture
Moorestown, N. J.

WILLIAM WEBSTER
 OCD Region Five
 Federal Regional Center
 Denton, Tex.

L. C. WELDON
 Agricultural Research Service
 U. S. Department of Agriculture
 Oklahoma City, Okla.

R. WENTWORTH
 Cornell University
 Ithaca, N. Y.

J. L. WEST
 UT-AEC Agricultural Research
 Laboratory
 Oak Ridge, Tenn.

EDWARD F. WILLIAMS, JR.
 USASTRATCOM-NCC(P)
 Springfield, Va.

RICHARD WILLIAMS
 Health Physics Department
 Brookhaven National Laboratory
 Upton, Long Island, N. Y.

A. A. WILSON
 School of Veterinary Medicine
 University of Cambridge
 Cambridge, England

EDWARD J. WILSON
 U. S. Department of Agriculture
 Hyattsville, Md.

WILLIAM E. WISEMAN
 Agricultural Research Service
 U. S. Department of Agriculture
 Chillicothe, Ohio

JOHN P. WITHERSPOON
 Ecological Sciences Division
 Oak Ridge National Laboratory
 Oak Ridge, Tenn.

J. H. WOMMACK
 Agricultural Research Service
 U. S. Department of Agriculture
 Sacramento, Calif.

PAUL E. ZIGMAN
 Environmental Science Associates
 Burlingame, Calif.

BROOKHAVEN NATIONAL LABORATORY

J. L. BATEMAN

L. COGGINS

N. C. COMBATTI

R. A. CONARD

F. P. COWAN

BRENDA FLOYD

D. D. GREENBERG

B. R. HOLT

A. JAHN

H. M. KALBACH

H. Z. KONDRATUK

C. B. MEINHOLD

A. NAUMAN

L. F. NIMS

J. O'CONNOR

J. S. ROBERTSON

R. C. SAUTKULIS

L. A. SCHAIRER

SUSAN S. SCHWEMMER

H. W. SIEGELMAN

RUTH C. SPARROW

J. G. STANGBY

N. TEMPEL

A. G. UNDERBRINK

AUTHOR INDEX

- Adams, D. R., 633
Anderson, J. J. B., 627
Auerbach, S. I., 643
Barth, D. S., 259
Bartlett, B. O., 548
Bell, M. C., 178, 193, 208, 627, 656
Black, S. C., 259
Bond, V. P., iii
Bottino, P. J., 306, 633, 670
Broce, A. B., 419
Broertjes, C., 325, 633
Brown, S. L., 51, 595, 639
Bruce, R. S., 548
Burdett, A. K., Jr., 645
Chertok, R. J., 125, 627
Cole, R., 639
Comar, C. L., 566
Constantin, J. J., 277, 287, 633
Cox, W. T., 627
Cromroy, H. L., 419, 643
Dahlman, R. C., 492, 639
Davis, J. A., 627
Davis, J. E., v
DiGregorio, D., 535, 643
Dodson, G. J., 509
Dunaway, P. B., 535, 643
Easton, B. M., 608, 645
Eisele, G. R., 269
Engel, R. E., 259, 627
Gamble, J. F., 643
Gaut, H. A., 645
Glubrecht, H., 343, 633
Goldman, L. J., 419
Greene, J. C., 1, 645
Griffin, S. A., 269, 645
Hall, N. S., 645
Hede, R., 639
Hekking, A. M., 639
Holland, L. M., 245
Holt, B. R., 482, 643
Hungate, F. P., 630
Johnson, J. E., 173, 405
Jones, D. C. L., 224, 627
Kantz, A. D., 56, 637
Killion, D. D., 277, 287, 633
Kitchings, J. T., III, 535
Kittel, W., 645
Koranda, J. J., 71
Krebs, J. S., 234
Lake, S., 125
Lane, W. B., 51, 107, 637
Lapham, D., 639
Lehnert, H. F., 633
Levy, R., 419
Lindquist, E. W., Jr., 643
Lovaas, A. I., 173, 405, 630
McAulay, J., 630
McCormick, J. F., 454, 643
McIntyre, D. R., 115
Mackin, J., 51

- Martin, J. R., 71
Mikhail, S. Z., 31, 627
Miller, C. F., 81, 639
Mistry, U. B., 645
Mitchell, M. J., 527
Murphy, P. G., 454, 643

Nape, W. F., 627
Neal, W. T. L., 616, 645
Ng, Y. C., 131, 639
Norman, J. H., 9, 637

Page, N. P., 648
Peters, L. N., 630
Platt, R. B., 352
Potter, G. D., 115, 627

Ragsdale, H. L., 352
Randecker, V. W., 259
Reichle, D. E., 527, 643
Rhoads, W. A., 352, 630
Romney, E. M., 352, 630
Rudolph, T. D., 633
Russell, R. S., 548, 633

Sand, P. F., 645
Sasser, L. B., 178, 193, 208, 627
Schmidt, C. H., 643
Schulz, R. K., 370, 630
Schwemmer, S., 670
Sharmon, E. C., 645
Siemer, E. G., 277, 287, 633
Simpson, R. E., 645

Spalding, J. F., 245
Sparrow, A. H., 306, 633, 670
Stangler, M. J., 645
Stannard, B., 643
Stern, V. M., 434
Still, E. T., 627, 648
Story, J. D., 535
Strope, W. E., 645
Styron, C. E., 509, 527, 643

Tanada, T., 633
Taylor, F. G., 630
Tewes, H. A., 131
Thompson, J. C., Jr., 566
Thompson, K. R., 627
Torkelson, D. E., 627

Van Hook, R. I., Jr., 521, 643
Vattuone, G. M., 115

Walter, G. H., 645
Warner, E. G., 645
Weldon, L. C., 627
Wentworth, R. A., 566
West, J. L., 178, 193, 208, 627
Wilson, A. A., 627
Winchell, P., 9
Witherspoon, J. P., 396, 527, 630
Wommach, J. H., 627
Woodwell, G. M., 482, 643

Zavitkovski, J., 633
Zigman, P., 637

SUBJECT INDEX*

-
- Abomasal tissue, concentration of air-borne radioiodine in, 259
- Abomasum
radiation-induced prolapse of, 186
radiation injury of, 178, 193, 210
- Absorption
of ingested ^{90}Sr , 586
inhibition of, 586
- Acheta domesticus* (L.) (see Cricket)
- Action measures to control radionuclide ingestion, 568
- Activation products
in meat, 161
in milk, 144-145, 159-161
- Acute gamma irradiation of plants, 287
- Adventitious buds, radiation response of, 325
- AET (2-aminoethylisothiuronium bromide hydrobromide), radioprotective effectiveness of, 239
- Agricultural damage assessment, 596-597
data base, 597
of assessed resources, 598
radiological considerations, 597
sensitivity analysis of, 602
use of research data in, 611
- Agricultural defense planning
committee report on, 645
information needs for, 645
use of damage-assessment data in, 608
- Agricultural resource distribution, sensitivity analyses of, 603
- Agriculture
damage assessment of, 596-597
data base of assessed resources of, 598
hazard of fallout on systems of, 496
of the Imperial Valley, 437, 447
postattack productivity of, 578
of the San Joaquin Valley, 447
vulnerability of, 595-596
sensitivity analysis of, 596
targeting pattern on, 88
- Agroecosystems
comparison with natural communities, 436-438
simple, 436
- Air
concentration of radionuclides in, 156
 ^{137}Cs in, 164
gas analysis of, in irradiated plant communities, 460
uptake of radioiodine through, 259
- Air-sampler data, use in exposure calculations, 259
- Air uptake of radioiodine by dairy cows, 259-267
- Airborne radioiodine uptake by dairy cows, 260
- Algae, radiosensitivity of, 485
- Alginate feed supplements, 586
reduction of ^{90}Sr absorption by, 586

*For many subjects listed in this index, only the initial page of the discussion is given.

- Allobophora*, role of, in fallout redistribution, 533
- Allocation of postattack food supplies, 578-579
- Aluminum phosphate gel feed supplement, 586
reduction of ^{90}Sr absorption by, 586
- Animal feed, food equivalents of, 578
- Animals
See also Cattle; Farm animals; Livestock;
Mammals; and specific animals
feeding of synthetic fallout to, 178
fractionated exposure of large, 651
mean survival time of large, 651
meat yield of, 622
salvage of irradiated, 269
survival of
 enhancement of, 625
 in fallout areas, 193
 in relation to cell destruction, 238
- Annual production loss of corn, 605
- Anorexia, internal radiation-induced
in sheep, 180
- Anterior ventral blind sac, pathological changes in, in sheep, 210
- Anthocyan accumulation in irradiated plants, 304
- Arabidopsis thaliana*, fallout exposure of, 344
- Artemisia*, radiosensitivity of, 353
- Arthropod community
chronic beta irradiation of, 510
threshold of radiation effects on, 509
- Arthropods
benefits of, 435
control of, 435
cost of, 435
immediate effects of radiation on populations of, 525
life-span of, 521
long-term effects of radiation on, 509
radiosensitivity of, 521
- Assessment
of early crop damage, 634
of radionuclide contamination in diet, 573
- Assimilation
of fallout by plants, 504
of fallout radionuclides, 87
of ingested radionuclides, 125-129
- Asteraceae*
beta irradiation of, 458
in outcrop plant communities, response to irradiation of, 468
- Attack
antipopulation, 94-104
casualties of, estimation, 561
counterforce, 88
credibility of directed, 606
damage assessment of, 614
date of, sensitivity
 analysis of, 602
dietary situation after, 566
environment after, action guides for, 568
hypothetical nuclear, 88-104
loss of pasture in, 622
radiation exposure guidelines for environment of, 591
specified levels of fatalities in, 94
survival of major crops and livestock in, 601
weight of, 605
 sensitivity analysis of, 605
- Auxin, destruction of, in irradiated plant, 478
- Axillary crevices, weathering of fallout from, 500
- Axillary growth of irradiated lettuce plants, 310
- Axillary shoots of irradiated plants, 302
- Barley
attack loss of, 622
chronic radiation injury to, 348
constant-rate exposure of, 322
radiation injury to germinating seeds of, 310
response of irradiated seedlings of, 306, 308, 313
 height, 307, 323
 lethality, 306, 318, 322
 United Kingdom stocks of, 619
 yield of irradiated plants, 683
- Beagles, fate of fallout ingested by, 125
- Beta burns, skin, 31
See also Radiation injury
- Beta dose
computation of, 31, 51
contact, 351, 501, 530
internal measurement of, 185-186
measurement of, 51, 637
multiple-particle model of, 39
to papillae
 of abomasum, 185-186

- of rumen, 185-186
 - single-particle model of, 32
 - to skin from fallout particles, 31, 39
 - TDD model of, 31-37
- Beta dosimetry, 51, 185-186, 374, 509
 - committee report on, 637
 - lithium fluoride, 51
- Beta-field hazard of fallout, 86, 623
- Beta-to-gamma ratio of fallout radiation, 190-191, 601
- Beta irradiation, fallout
 - of corn, 370
 - ecological effects of, 454, 458, 510
 - of gastrointestinal tract, 193
 - of lettuce, 370
 - of outcrop plant communities, 458
 - of skin, 31, 187, 193, 199
 - multiple-particle injury criteria, 41
 - single-particle injury criteria, 37
 - of vegetation, 353, 362-363, 455
 - of wheat, 370
- Beta radiation
 - See also* Beta radiation, fallout; Fallout radiation
 - contribution of, to fallout radiation dose, 623
 - dose (*see* Beta dose)
 - dosimetry, 51, 185-186, 374, 509, 637
 - ecological effects of, 454, 458, 510
 - effects on farm animals, 565, 627, 662
 - effects on insects, 510
 - effects on plants, 51, 362-363, 370, 455
 - internal effects of, 185-186, 193, 659
 - lesions of the skin from, 37
 - measurement of, 51
 - Relative Biological Effectiveness of, 477
 - shielding of, by soil, 531
 - source, 528
 - sensitivity to
 - of earthworms, 527
 - of plants, 631
- Beta radiation, fallout, 31, 51, 56
 - contact dose of, 530
 - field, 476
 - hazard of, 86, 623
 - importance of, 623
 - livestock information needs, 628
 - radiobiological effects of, 634
 - skin lesions from, 37
 - summary of effects of, on livestock, 627
 - vulnerability of crops to, 630
- Beta radiosensitivity
 - of earthworms, 527
 - of plants, 631
- Biological considerations
 - availability of radionuclides, 125
 - contamination of postattack foods, 567
 - control of insects, 451
 - dosimetry, 509
 - end points of radiation injury, 234-235
 - fallout hazard, 492
 - half-life of ^{137}Cs , 589
 - indicators of species radiosensitivity, 419
- Biomass
 - of irradiated plant communities, 468, 478
 - of irradiated *Viguiera portevi*, 477
 - yield of irradiated plant communities, 462
- Biota, release of nutrients from, 487
- Blood assay, determination of ^{131}Cs body burden by, 576
- Body burden
 - ^{137}Cs , determination of, 576
 - radionuclide, urinary assay of, 576
- Body weight
 - of internally irradiated sheep, 180
 - of irradiated cotton rats, 542
- Bone
 - dose to, 161
 - radionuclides in, 117-124
 - fetus, 117-123
 - tungsten, 122-124
- Bone marrow
 - biological indicator of radiation dose in, 235
 - DNA content of, 237
 - recovery from radiation injury, 252
 - ^{90}Sr dose to, 557
- Buildup plus fallout-decay-simulated (Bu + FDS) radiation exposure of
 - plants, 306-307, 310, 323
- Bulbostylis capillaris*, radiation response of, 476
- Burro
 - LD₅₀ of, 650
 - mean survival time of, 651
 - radiation lethality of, 657
- Cabriolet, fallout radiation from, 353

- Calcium
 deficiency in nondairy diet, 580
 in feed, effect on strontium-to-calcium ratio in milk, 585
 supplementation in nondairy diet, 580
- Calculational techniques of beta dosimetry, 637
- Canopy
 of irradiated plant communities, 462
 retention of fallout by, 504
 stratification in irradiated plant communities, 470
- Carbon dioxide exchange rate of irradiated plant communities, 465, 474, 479
- Casualties, estimates of attack, 561
- Cattle
See also Animals; Dairy cows, Farm animals; and Livestock
 diarrhea in irradiated, 197
 effect of fallout on, 662
 fallout retention by, 173
 hyperkeratosis of skin irradiated, 199
 internal radiation injury of, 210
 pathology of, 210
 LD₅₀ of, 650
 mean survival time of, 651
 passage of ingested fallout by, 177
 radiation injury of, 193
 radiation lethality of, 657
 simulated-fallout effects on mortality of, 661
- Cell destruction as related to animal survival, 238
- Cells
 doubling time of, 242
 radiosensitivity of, 237
- Cereal-grain crops, retention of fallout by, 501
- Cereals
 postattack requirement for, 624
 postattack yield of, 624
 radiosensitivity of, 688, 693
 stocks of, in United Kingdom
 postattack availability of, 619-620
 postattack requirements for, 619-620
- Cerium-144, ingested, internal injury in sheep caused by, 178
- Cesium-137
See also Radiocesium
 accumulation and retention by cotton rat of fallout, 536, 539-542
 assay of body burden of, 576
 biological half-time of, 589
 control of secretion in milk by Prussian blue, 589
 inhibition of absorption of, by Prussian blue, 589
 intake commitment from milk, 570
 internal dose contribution of whole-body, 549
 irradiation by
 of barley, 306
 of lettuce, 306
 of wheat, 306
 in milk, 163
 as radiation source, 307, 483
 in surface air, 164
- Cesium-tagged synthetic fallout, accumulation by cotton rat, 536
- Chemical contamination of postattack foods, 567
- Chemical properties of fallout, 82-86
- Chronic beta irradiation of an arthropod community, 510
- Chronic contamination by worldwide fallout, 156
- Chronic irradiation
 of barley, 348
 of forest, 483
 of a natural plant community, 483
 of rye, 348
 of trees, 483
 of wheat, 348
- Cities, evacuation of, 103
- Climatic conditions, effect on radiosensitivity of plants, 348
- Close-in fallout, simulated
 exposure of plant communities to, 458
⁹⁰Y tagged, 458
- Cobalt-60
 irradiation of sheep, 179
 as source of gamma radiation, 455
 stimulation of plant growth by irradiation with, 456
- Collembola (*Folsomia*)
 population study of irradiated, 511
 radiosensitivity of, 509-510, 517-518
- Colony-forming unit (CFU), 235
- Color of irradiated crops, 675
- Combined radiation effects on livestock, 660
- Communities, radiosensitivity of plant, 485
- Condensation of fission products, 83

- Coniferous forest, radiosensitivity of, 489
- Constant-rate exposure
 of barley, 322
 of crop plants, 306-307, 310, 313, 322
 comparison with FDS, 322-323
 of lettuce, 310, 322
 of wheat, 322
- Contact beta dose, 351, 501, 530
- Contact beta hazard, 86
- Contamination (*see* Fallout, contamination from)
- Contamination factor of fallout retention on crops, 494, 501
- Control of insect pests, 439-442, 448, 451
- Corn (*Zea Mays*)
See also Maize
 annual production loss of fallout irradiated, 605
 beta injury of fallout irradiated, 370
- Cost of decontaminating milk, 589
- Cotton rat (*Sigmodon hispidus*)
 accumulation of fallout cesium by, 536, 539-542
 body weight of irradiated, 542
 distribution of ingested cesium in, 541-542
 internal beta irradiation of, 539
 internal gamma irradiation of, 539
 in vivo dosimetry of, 536
 retention of fallout cesium by, 536
- Counterforce attack, 88
- Countermeasures
 to ^{137}Cs absorption, 589
 to livestock exposure, 666
 to radionuclide intake from milk, 570
 to ^{90}Sr absorption, 588
- Cows, dairy (*see* Cattle; Dairy cows; and Livestock)
- Crabgrass (*Digitaria* species), radiosensitivity of, 486
- Cricket [*Acheta domesticus* (L.)]
 dose-rate effect on, 524
 dosimetry of, 512
 irradiation of, 522
 lethality of, 522
- Crops
See also Agriculture; Plants; and specific crops
 color of irradiated, 675
 committee report on, 630, 633
 beta radiation vulnerability of, 630
 gamma radiation vulnerability of, 633
 constant-rate exposure of, 306-307, 310, 313, 322, 313, 322-323
 contamination of, by fallout, 343
 contamination factor of fallout retention on, 494, 501
 damage assessment of, 597, 634
 fallout effects on, 288, 632, 635, 702
 fallout retention of, 401-402, 405
 forage, 144, 158, 692, 694
 LD_{50} of, 313
 period of vulnerability of, 607
 protein content of irradiated, 675
 radiation exposure of, 288
 radiation injury of, 634
 radiation lethality of, 600
 radiation reduction of yield of, 670
 radiosensitivity of, 704
 root, radiosensitivity of, 690, 693
 starch content of irradiated, 675
 sugar content of irradiated, 675
 survival of irradiated, 313
 taste of irradiated, 675
 in United Kingdom
 attack losses of, 622-623
 stocks of, 619
 yield of irradiated, 313
- Dairy cows
See also Animals; Cattle; and Livestock
 control of ^{137}Cs secretion in milk of, 589
 fate of fallout ingested by, 115
 ingestion of fallout by, 144
 uptake of airborne radioiodine by, 259-267
- Damage, radiation
See also Radiation injury
 fallout, 82
 to plants, 347
- Damage-assessment analysis, 88
 of agriculture, 596-597
 of current weapons systems, 88-91
 of food crops and livestock, 597
 of future weapons systems, 91-104
 of nuclear attack, 614
 use of research data in, 611
- Damage-assessment data
 application in agricultural defense planning, 608
 source of, 610
- Date of attack, sensitivity analysis of, 602

- Debris, fallout
See also Fallout
 ingestion by dairy cows, 115
 from Plowshare, 115, 125
- Deciduous forest, radiosensitivity of, 489
- Decontamination
 effectiveness of, 590
 of food, 590
 of land, 589
 of milk, 560, 589
 of water, 590
- Defense planning, agricultural (*see* Agricultural defense planning)
- Deposition of fallout radionuclides, 156-157
- Detector, radiation, lithium-drifted germanium, 125
- Development of irradiated plants, 287, 301-302
- Device materials, neutron activation of, 133-135
- Diarrhea
 in irradiated sheep, 180
 in irradiated steers, 197
- Diet
See also Food; specific foods
 alginates in, to control ^{90}Sr absorption, 586
 consequence of eliminating milk from, 580, 586
 contamination of, food indicators of, 573
 control by
 of ^{131}I intake, 581
 of populations, 569
 of radionuclide ingestion, 579
 importance of milk in, 586
 on calcium intake, 586
 on ^{90}Sr -to-calcium ratio, 586
 postattack conditions relating to, 566
 Prussian blue in, as countermeasure against ^{137}Cs , 589
 radionuclide contamination of, 573
 ^{90}Sr level in, estimation of, 575
- Diffusion of fallout radionuclides, 83
- Direct fallout contamination of food, 549-554
- Dispersal of food stocks, 618
- Dispersion of insect pest species, 445-447
- Dose
See also Radiation dose
 from activation products in meat, 161-163
 beta (*see* Beta dose)
 bone, 161
 estimation of, 144
 fallout
 commitment from ^{90}Sr , 558
 internal, 137
 large particle, 161-163
 reduction by polyethylene covers, 367
 from fallout ^{137}Cs , 558
 from fallout-contaminated food, 131
 from fission products in meat, 161-163
 fractionated
 of fast neutrons, 325, 338-339
 of X rays, 325, 338-339
 gamma-ray, estimation of, 358
 from ingested ^{90}Sr , 556
 internal, 156
See also Internal dose
 from ingested fission products, 555-559
 from large fallout particles, 161
 measurement of, 353
 direct, 69
 from meat, 161-163
 from milk, 144
 model of, 156
 from small fallout particles, 158-159, 163
 thyroid, 161
 total, from ingested fallout, 559
 to vegetation from Schooner fallout, 360-361
 whole body, 161, 539
- Dose fractionation, protection induction of, 325, 332, 339
- Dose-rate effect, 225
 on cricket, 524
 plateau region of curve for insects, 525
- Dose-rate multiplier, sensitivity analysis of, 605
- Dosimeter
 beta, 51
 design, 57
 glass-rod, 536
 micro-, lithium fluoride, 509
 for sheep, 185
 thermoluminescent, lithium fluoride, 459, 464
- Dosimetry, 463-464
 of beta and gamma radiation, 509
 of beta radiation, 51, 374, 637

- of cotton rats, 537-539
 - in vivo, 536
 - of crickets, 512
 - of fallout radiation, 354
 - of fission products, 75
 - of grasshoppers, 512
 - of grassland vegetation, 509
 - of insects, 509
 - of plant communities, 458
 - of shrubs, 354
 - of tritium, 72-75
- Early fallout, internal dose from, 137
- Earthworms (*Lumbricus terrestris*)
- beta irradiation of, 533
 - sensitivity to, 527
 - fallout effects on, 533
 - importance of, 528
 - irradiated
 - fecundity of, 533
 - fertility of, 533
 - histological damage of, 530
 - injury of, 530
 - intestinal necrosis of, 530
 - lethality of, 529, 532
 - irradiation of, 533
 - lethal time (LT₅₀) of, 528-529
 - radiosensitivity of, 527-528
 - redistribution of fallout by, 532-533
- Ecological effects
- of beta radiation, 454, 458, 510
 - of fallout, 82
 - radio-, 643
 - of simulated fallout, 454, 458
- Economic-injury level of insect pests, 451
- Economic plants
- deleterious radiation effects on, 684
 - LD₅₀ of 30 species of, 685
- Economic threshold
- of insect pests, 451
 - of pest arthropods, 441
- Ecosystems
- See also Agroecosystems
- fallout effects on, 82
 - granite outcrop, description, 456
 - irradiated
 - carbon dioxide exchange of 459-461, 465, 474, 479
 - metabolism of, 449-461, 465, 474-476
 - net production of, 459-461, 465, 474
 - respiration of, 459-461, 465, 474
 - structure of, 483
 - radiation exposure of, 454
 - radiosensitivity of, 703
 - species diversity in, 475
 - species succession in, 475
 - stress of radiation on, 474
 - Emergence of seedlings of irradiated parent plants, 289
 - Energy, plant fixation of, 486
 - Energy flow
 - in ecosystems, 475
 - in irradiated plant communities, 479
 - Environment, influence on plant radiosensitivity, 670, 679-681, 702
 - Environmental materials, neutron activation of, 133-136
 - Equilibrium position of insect pests, 442
 - general, 451
 - temporary, 452
 - Equine, fallout radiosensitivity of, 662
 - Erythropoietin response, 235
 - Excretion
 - of fallout, 115, 123, 173
 - of radionuclides, 125
 - Exposure calculations, use of air-sampler data in, 259
 - Exposure duration, response of lettuce to variations of, 310
 - Exposure index of radiation, 568
 - Exposure rate, radiation
 - constant (see Constant-rate exposure)
 - decay of, 307
 - response of barley to variations of, 313
 - response of plants to variations of, 306-307, 310, 314, 317-323
 - Exposure-rate contours of fallout, 531
 - Exposure-rate pattern of plant irradiation, 307, 323
 - Exposure time, response of plants to variations of, 306, 308
 - External gamma hazard of fallout, 82, 86
 - External irradiation of earthworms, 533
- Fallout
- See also Debris, fallout; and Fallout radiation
- assimilation
 - by plants, 504
 - of radionuclides from, 87
 - beta (see Beta radiation, fallout)
 - beta and gamma exposures, 353
 - beta and gamma radiation
 - dose, 56

Fallout (continued)

- livestock vulnerability to, 627
- beta exposure of vegetation, 353, 362-363
- beta-to-gamma ratio, 190-191, 601
- beta-radiation field, 476
 - hazard of, 86, 623
- biological availability of, 84, 125
- biological hazard of, 492
- chemical properties of, 82-86
- close-in, 102
 - simulated, 458
- contact beta dose from, 531
- contamination from
 - of crops, 343
 - of diet, indicator of, 569
 - of food, 496
 - direct, 549-554
 - of grass, 494
 - of meat, 161
 - of milk, 144, 549, 554, 569
 - comparison of U.K. and N. Temperate Zone levels, 554
 - lag effect of, 548-550, 554
 - rate of ^{90}Sr uptake from soil, 553
 - of postattack diet, 567
 - of shrubs from Project Schooner, 352
 - surface, 352
- damage to plant communities, 483
- decay of radiation exposure rate, 307
- deposition of, 156-157
- diffusion of, 83
- direct contamination of food by, 549
- distribution of, 86, 639
- dose (*see* Dose)
- ecological effects of, 82
- effects on plants, 670
- effects on vegetation, 363
- excretion of, 115-123, 173
- exposure of *Arabidopsis thaliana* to, 344
- exposure of plant communities to, 455
- exposure rate, contours of, 531
- forage-cow-milk pathway, 144, 158
 - small particles, 144
- formation of, 83-86
 - See also* Fallout formation
- gamma and beta radiation dose, 56
- gamma radiation, 56, 82, 86
 - See also* Gamma radiation dose, 358
 - hazard, 86

- gamma-ray exposure of vegetation, 360-361
- hazard to agriculture, 496
- hazard, 100% lethal radius, 102
- ingestion of, 115, 125, 131, 178, 193
- inhalation hazard of, 86
- initial retention by plants, 397, 493
- interception by plants, 501
- intermediate range, 97
- internal dose from, 137
- large particles of, 161
 - dose from, 161-163
- leaching of, 17-28
- local, biological hazard of, 492
- model, particle weathering function, 496
- movement of, 533
- particles of, 82
 - See also* Fallout particles
- pattern, exposure-dose perimeter, 99
- physical properties of, 82-86
- Plowshare, 115, 125
- properties of, 82-86, 639
- protection (*see* Fallout protection)
- radiation from (*see* Fallout radiation)
- radiation damage of, 82
- radiation dose from, 161, 163, 623
 - See also* Dose
- radiation field of, 639-640
- radiation field of simulated, 472
- radioactivity from (*see* Fallout radioactivity)
- radiobiological effects of, 82
- radiological hazard of, 86-88
- radionuclides from (*see* Fallout radionuclides and Radionuclides)
- rate of passage through gut, 175
- redistribution of, by earthworms, 532-533
- retention of
 - by agricultural plants, 401-402
 - by animals, 86
 - by cattle, 173
 - by cereal and grains, 501
 - by crops, 396, 405
 - in fetal tissues, 115
 - by humans, 86
 - by maize, 501
 - in maternal tissues, 115
 - negative exponential model of, 496
 - by plant foliage, 87, 501
 - contamination factor of, 501

- by plants, 396, 397, 401-402, 405, 493, 504
- by sorghum, 499
- by trees, 401-402
- Schooner, 117-124
- secretion in milk, 115-123
- shelters, 97-98
- simulant (*see* Fallout simulant)
- simulated (*see* Simulated fallout)
- specific activity of, 86
- stratospheric, 85-86, 156-157, 163, 343
- synthetic, 107-108
 - use of, 173, 178, 193
- tritium, 74-75
- tropospheric, 343
- uptake of residual, by food crops, 549
- weathering loss from plants, 400, 496, 500
- worldwide deposition of, 85-86, 156-157, 163
- Fallout beta radiation (*see* Beta radiation, fallout)
- Fallout decay simulation (FDS), 306
 - comparison with uniform exposure, 322
 - of plant radiation exposure, 306, 313, 322
- Fallout field, gamma and beta doses in, 56
- Fallout formation
 - agglomeration of particles, 84
 - condensation of fission products, 83
 - Condensed-State Model of, 11-17
 - diffusion of radionuclides, 83
 - fireball interactions, 83
 - fractional condensation of radionuclides, 83
 - model of, 10
 - vaporization of radionuclides, 83
- Fallout gamma-ray dose, estimation of, 358
 - radiological monitoring data for, 358
- Fallout particles
 - agglomeration of, 84
 - computation of beta doses from, 31-50
 - fission-product profile in, 11
 - radioelements in, 83
 - radiological dose from, 158-159, 163
 - retention by terminal buds, 473
- Fallout protection (PF)
 - of concrete buildings, 98
 - of wood-frame buildings, 97
- Fallout radiation
 - assessment of agricultural losses from, 597
 - beta-to-gamma ratio in, 87
 - from Cabriole, 353
 - decay rate of, 82
 - direct dose measurement of, 69
 - dosimetry of, 354
 - effects on crops, 288, 632, 635
 - information needs, 632, 635
 - effects on farm animals, 656
 - effects on a grass community, 542
 - effects on hemopoietic system, 536
 - effects on livestock, 628-629, 662
 - information needs, 628-629
 - energy spectrum of, 82
 - gamma, exposure of vegetation to, 360-361
 - gamma component of, 306
 - hazard of, 496
 - immediate effects on insects, 525
 - intensity of, 493
 - internal hazard of, 87
 - long-term effects on arthropods, 509
 - radioecological effects of, 643
 - standard intensity (I_S) of, 91
 - total-to-gamma dose ratio, 600, 603
- Fallout radiation dose, contribution of beta radiation, 623
- Fallout radiation field
 - committee report on, 639
 - prediction of, 639-640
- Fallout radioactivity
 - accumulation by cotton rat, 536
 - content of intestinal tract of cotton rat, 536
- Fallout radionuclides
 - See also* Radionuclides; specific radionuclides
 - assimilation by man and animals, 87
 - biological availability of, 84
 - in bone, 115
 - contamination of food chains by, 87
 - excretion of, in urine, 115-123
 - ^{74}As , 115, 117, 120
 - ^{131}I , 115, 117, 120
 - ^{103}Ru , 115, 117, 120
 - ^{132}Te , 115, 117, 120
 - ^{181}W , 115, 117, 120
 - ^{187}W , 115, 117, 120
 - ^{188}W - ^{188}Re , 115, 117, 120
 - ingestion of, 87, 131
 - maternal-fetal transport of, 117-124

- Fallout radionuclides (continued)
 potential solubility of, 84
 secretion in milk, 115
- Fallout simulant, 107
 See also Simulated fallout; Synthetic fallout
 application of, 372
 fate of, 541
 leachability of, 495
 mass load of, 495
 particle size of, 495
 properties of, 494
 ⁸⁶Rb labeled, 494-495
 ⁹⁰Y, radiochemical purity of, 371
- Fallout weathering, semilogarithmic regression model of, 500-501
- Farm animals
 See also Animals; Cattle; Livestock; and specific animals
 ecological effects of beta radiation on, 565, 627, 662
 radiation effects on, 628-629, 656, 662
- Feed
 aluminum phosphate gel supplement, 586
 animal, food equivalents of, 578
 intake of, by internally irradiated sheep, 180
- Feeding of synthetic fallout to animals, 178
- Festuca arundinacea* Schreb, fallout contamination of, 510
- Field studies of fallout retention by crops, 396
- Fireball, nuclear, 83
 toroidal motion in, 84
- Fission products, 133-137
 biological availability of, 11
 condensation of, 83
 dosimetry of, 75
 fractionation of, 10
 incorporation in meat, 161
 ingested dose from, 555-559
 ingestion of, 131
 leaching of, 17-28
 mobility of, 11
 radionuclides in, 82
 secretion in milk, 144-145, 158
 transfer of, 560
- Foliar retention of fallout, 87, 501
- Folsomia* (Collembola) [*see* Collembola (*Folsomia*)]
- Food
 See also Diet; Foodstuffs; and specific foods
 availability, survey of, 577
 average U.S. supply of, 578
 chemical contamination of postattack, 567
 contamination model, source term, 504
 decontamination effectiveness of processing, 590
 emergency use of, 577
 equivalents of animal feeds, 578
 fallout contamination of, 496, 549
 remedial action plans, 560
 imports of United Kingdom in peacetime, 617
 postattack allocation of, 578-579
 postattack rationing of, 578-579
 postattack resources in United Kingdom (*see* United Kingdom)
 ⁹⁰Sr contamination of, 579
 milk, 554
 processing reduction of, 579
- stocks
 dispersal of, 618
 geographic distribution of, in United States, 577
 normal quantities on hand in United Kingdom, 617
 quantities in marketing channels, 577
- Food chain, transfer of fission products in, 560
- Food-crop plants (*see* Crops)
- Food indicators of dietary radionuclide contamination, 573
- Food stocks (*see* Food)
- Foodstuffs
 See also Diet; Food; and specific foods
 fallout contamination of, 131
 worldwide fallout contamination of, 549
- Forage, fallout contamination of, 144
- Forage-cow-milk pathway
 passage of small-particle activity, 144
 transfer of large-particle activity, 158
- Forage crops, radiosensitivity of, 692-694
- Forest
 See also Plants; Trees; Vegetation; and specific plants
 coniferous, radiosensitivity of, 489

- deciduous, radiosensitivity of, 489
- radiation response of, 483-486
- Fruit set, tomato, influence of postirradiation time on, 682
- Fruit trees, radiosensitivity of, 691, 694
- Fungi, radiosensitivity of, 485

- Gametogenesis, radiation effects on, 304
- Gamma component of fallout radiation, 306
- Gamma exposure rate, response of soybean plants to variations of, 277
- Gamma irradiation
 - acute, of plants, 287
 - internal, of the cotton rat, 539
 - of livestock, 624
 - summary of information on, 628
 - of soybean plants
 - Hill, 278-280
 - Kent, 278-280
 - tolerance of plants to, 302
- Gamma radiation
 - See also* Fallout radiation
 - acute exposure to, 245
 - beta-to-gamma ratio of fallout, 190-191
 - dose, 358
 - dosimetry of, 509
 - effects, livestock information needs, 629
 - effects on farm animals, 627, 656
 - fallout, 56, 82, 86, 306
 - external hazard of, 82, 86
 - whole-body dose of, 539
 - protracted exposure of, 245
 - source of, 455, 528
- Gamma-ray dose, estimation of, 358
- Gamma-ray exposure, 353
 - of soybean (*Glycine max* (L.) Merrill), 277
 - of vegetation, 360-361
- Gas analysis of air, 460
 - of irradiated plant communities, 460
- Gastrointestinal contents of cotton rat
 - ^{137}Cs concentration of, 541-542
 - fallout radioactivity of, 536
- Gastrointestinal pathology of irradiated livestock, 208, 210, 212
- Gastrointestinal radiation injury of livestock, 208, 210, 212
 - microscopic observations of, 217
 - of sheep, 186

- Gastrointestinal tract
 - beta irradiation of, 193
 - beta radiation injury of, 659
 - ^{137}Cs content of, tissue of cotton rat, 536, 541-542
 - dose rate to cotton rat, for internal and external irradiation, 539
 - irradiation of, 178-179
 - measurement of beta dose in, 185-186
 - pathology of beta radiation injury of, 208, 210
 - rate of fallout passage through, 176
- General equilibrium position of insects, 442, 451
- Genetic effects of radiation, 248, 666
- Genetic injury of nonlethal exposures, 245
- Genetic involvement of hematopoietic recovery, 248
- Genetic response of irradiated earthworms, 533
- Germinal cells, skin, radiation response of, 236
- GI tract (*see* Gastrointestinal tract)
- Glass-rod dosimeter, 536
- Goat
 - continuous irradiation of, 651
 - LD_{50} of, 650
 - mean survival time of, 651
- Governing mechanism of insect populations, 452
- Grain
 - postattack yield of, in the United Kingdom, 624
 - seed, irradiation of, 685
 - stocks of, in the United Kingdom, 619-620
- Granite-outcrop ecosystem, description of, 456
- Granite-outcrop plant community
 - plasticity of, 478
 - radiation exposure of, 454
- Grass, fallout contamination of, 494
- Grasshopper (*Melanoplus* species), dosimetry of, 512
- Grassland, dosimetry of, 509
- Grazing of contaminated pasture, 193
- Growth of irradiated *Viguiera porteri*, 462, 471, 476-477
- Growth stimulation of irradiated lettuce, 310

- Guides, postattack action. 568
- Gut (*see* Gastrointestinal tract)
- Hardwood trees, radiosensitivity of, 694
- Hematologic changes in irradiated sheep, 227
- Hematopoietic recovery, 248
- Hemopoietic system, radiation response of, 536
- Herbs, radiosensitivity of, 485
- Hernial ring, radiation-induced prolapse of, 186
- High shrubs, radiosensitivity of, 485
- Higher plants, radiosensitivity of, 483
- Histological damage of irradiated earthworms, 530
- Home water softeners, decontamination effectiveness of, 590
- Homeostasis of irradiated plant communities, 478
- Human cells, radiosensitivity of, 237
- Hyperkeratosis of skin-irradiated cattle, 199
- Hypothetical nuclear attack, 88-104
See also Attack
- ICV (*see* Interphase chromosome volume)
- Imperial Valley agriculture, 437, 447
- Index
of dissimilarity of species composition, 514
leaf area, for irradiated plant communities, 462, 469, 477-478
radiation exposure, 568
- Ingested dose from fission products, 555-559
- Ingested fallout, 115, 125, 131, 178, 193
elimination of, 115-123
fate of, 115-124
internal concentration of, 115-123
retention in fetal tissues, 115
retention in maternal tissues, 115
secretion in milk, 115
- Ingested radionuclides, retention of, in internal organs
bone, 115
kidney, 115
liver, 115
spleen, 115
- Ingestion
of fallout, 115, 125, 131, 178, 193
of fission products, 87, 131
of radioactivity by livestock, 193
of radionuclides, 87, 131
of synthetic fallout, 193
- Inhalation hazard of fallout, 86
- Initial retention of fallout by plants, 397, 493
- Injury (*see* Radiation injury)
- Insect pests
control of, 439-442, 448, 451
destruction by
of balsam fir by spruce budworm, 348
economic threshold of, 451
of lodgepole pine by needle miner, 348
dispersion of, 445-447
equilibrium position of, 442
origin of, 439-442
species of, 439-442
of the San Joaquin Valley, 448
- Insects
See also Insect pests; specific insects
adaptability of, 434
beta-radiation effects on, 510
biological control of, 451
dose-rate effect curve, plateau region for, 525
dosimetry of, 509
economic control of, 451
economic-injury level of, 451
equilibrium position of, 442
general, 442, 451
temporary, 452
immediate effects of fallout radiation on, 525
irradiated, life-span shortening of, 428
mortality, 522
natural control of, 452
population dispersal of, 452
prediction of radiosensitivity of, 426-430
radiosensitivity of, 434
temporary equilibrium position of, 452
- Interception of fallout by plants, 501
- Intercontinental missiles, 91-92
Minuteman-3, 92
Poseidon, 92
SS-9 Scarp rocket, 92
SS-11, 92
- Intermediate-range fallout, estimation of, 97
- Internal dose, 156
See also Dose; Internal radiation dose
from fallout, 137

- from fallout-contaminated food, 131
- from ingested fission products, 555-559
- from stratospheric fallout, 163
- Internal hazard of fallout, 86
- Internal irradiation
 - of cotton rat, 539
 - of earthworms, 533
- Internal organs of cotton rat
 - ^{137}Cs content of, 541-542
 - fallout radioactivity of, 536
- Internal radiation dose, relative contribution to
 - of ^{137}Cs , 549
 - of ^{131}I , 549
 - of ^{90}Sr , 549
- Interphase chromosome volume (ICV)
 - indicator of species radiosensitivity, 673, 695-696, 419
 - prediction of LD_{50} for plants, 673
- Intestinal epithelium, radiation response of, 235
- Intestine
 - necrosis of, in irradiated earthworms, 530
 - radiation injury of, 186
- Iodine-131, 260
 - See also* Radioiodine
 - blocking of, in thyroid, 581
 - contribution to internal dose, 549
 - dietary control of intake of, 581
 - intake commitment of, from milk, 570
 - secretion in milk, 115, 118
 - thyroid irradiation, 548
- Ion exchange, decontamination of milk, 589
- Irradiated ecosystems (*see* Ecosystems, irradiated)
- Irradiated plant communities, 458
 - appearance of, 465
 - biomass of, 462, 468-478
 - canopy stratification of, 462, 470
 - carbon dioxide exchange in, 459-461, 465, 474, 479
 - energy flow in, 479
 - gas analysis of air in, 460
 - homeostasis of, 478
 - leaf-area index of, 462, 469, 477-478
 - litter accumulation of, 462, 471, 478
 - Margalef pigment-diversity ratio of, 474, 478
 - metabolism of, 465, 474-476
 - pigment diversity of, 463, 472, 478
 - species composition of, 462, 468
- Irradiated sheep (*see* Sheep)
- Irradiation (*see* specific types of irradiation; specific classes of plants and animals; and specific plants and animals)
- Kalanchoe blosfeldiana*, fallout exposure of, 344
- Lactuca sativa* (*see* Lettuce)
- Land decontamination, 589
- Latent period of insect mortality, 522
- LD_{10} (lethal dose) of plants, 674
 - correlation with ICV, 674
- LD_{50} (lethal dose), 599
 - of barley, 306, 318, 322
 - of burro, 650
 - of cattle, 650
 - of cricket, 522
 - of crops, 313
 - of earthworm, 528-529
 - effect of dose rate on, 225
 - of 82 species of woody plants, 700-701
 - of fallout-exposed livestock, 648, 656
 - of goat, 650
 - of insects, 428
 - of large animals, 225
 - of lettuce, 306, 310, 318, 322
 - comparison of constant-rate and FDS exposure, 322
 - of livestock, 648, 656, 662
 - of offspring of irradiated seeds, 685
 - of plants, 322, 673
 - correlation with ICV, 673
 - in relation to ICV, for mammals, 420-425
 - of sheep, 187, 225, 650
 - of swine, 650
 - of 30 economic plants, 685
 - of wheat, 306, 318, 322
 - comparison of constant-rate and FDS exposure, 322
- Leachability of fallout simulant, 495
- Leaching
 - of fallout particles, 17-28
 - mechanism of, 17-28
- Leaf-area index of irradiated plant communities, 462, 469, 477-478
- Leaf blades
 - retention of fallout by, 501
 - weathering of fallout from, 500

- Legumes, radiosensitivity of, 689, 693
- Lethal dose (see LD_{10} and LD_{50})
- Lethal fallout area, radius of, 102
- Lethal radiation exposure, 246
- Lethal time (LT_{50}) of earthworm, 528
- Lethality
 See also LD_{10} and LD_{50}
 effect of postirradiation time on plant, 684
 of irradiated earthworms, 529, 532
- Lettuce (*Lactuca sativa*)
 beta irradiation of, 370
 constant-rate (CR) exposure of, 310, 322
 effect of dose rate on, 323
 fallout-decay-simulation (FDS) exposure of, 322
 growth stimulation of irradiated, 310
 irradiation of, 306-307, 310
 LD_{50} of, 306, 310, 318, 322
- Lichens, radiosensitivity of, 485
- Life-span
 radiation effects on, 666
 shortening of, in irradiated insects, 428
- LiF (see Lithium fluoride)
- Lithium detector, 125
- Lithium fluoride microdosimeter, 509
- Lithium fluoride thermoluminescent dosimeter, 459, 464
- Litter accumulation in irradiated plant communities, 462, 471, 478
- Liver abscesses in irradiated sheep, 190
- Livestock
 See also Animals; Cattle; Dairy cows; and specific animals
 beta-radiation effects on, 627
 beta-radiation injury to
 abomasum, 193, 210
 internal, 659
 omasum, 210
 pathology of, 210
 combined radiation effects on, 660
 committee report on vulnerability of, 627
 concentration of airborne radioiodine in, 259
 damage assessment of, 597
 fallout protection of, 666
 fallout radiation effects on, 628-629, 662
 gamma-radiation vulnerability of, 628
 gastrointestinal tract
 irradiation of, 193
 radiation injury of, 208, 210, 212, 217
 ingestion of radioactivity by, 193
 irradiated
 causes of death of, 648
 recovery of, 648
 reproduction of, 665
 salvage of, 269
 LD_{50} of, 648, 656, 662
 pasture requirement of, 621
 postattack survival of, United Kingdom estimates of, 621
 productivity of
 effects of fallout on, 193
 radiation effects on, 663
 radiation effects on, 193, 656, 663
 radiation-induced diarrhea in, 197
 radiation-induced pyrexia in, 196
 retention of airborne radioiodine by, 259
 skin beta irradiation of, 193, 199
 whole-body irradiation of, 193
- Local fallout, biological hazard of, 492
- Lodgepole needle miner [*Coleotechnites milleri* (Busck)], 348
- Lolium multiflorum*, fallout exposure of, 344
- Low shrubs, radiosensitivity of, 485
- Lumbricus terrestris* (see Earthworms)
- Lungs, radiation injury of, 187
- Maize (*Zea Mays*)
 See also Corn
 radiosensitivity of, 679
 retention of fallout by, 501
- Mammals
 See also specific categories of mammals
 irradiated, mean survival time of, 420
 radiosensitivity of, 420
 recovery from radiation injury of, 245
- Margalef pigment-diversity ratio
 of irradiated plant communities, 474, 478
 of irradiated *Viguiera porteri*, 463
- Mass load of simulated fallout, 495
- Mean expectation of future life (e_x) of insects, 522
- Mean survival time
 See also under specific plants and animals
 of irradiated mammals, 420

Measurement

- See also* Dosimetry
- of beta dose, 51, 637
- of radiation dose, 353
- of radiation injury, 235

Meat

- See also* Food
- activation products in, 161
- animal yield of, 622
- fallout contamination of, 161
- internal dose from, 161-163
- postattack availability of, 622
- radiation effects on production of, 663

Meristems, beta exposure of, 455

- Metabolism of irradiated ecosystems, 459-461, 465, 474-476

Microarthropods, radiosensitivity of, 485

Military targets, nuclear attack on, 88

Milk

- See also* Food
- activation products in, 144-145, 159-161
- ^{137}Cs contamination of, 163
- decontamination of, 560, 589
- effect of elimination of, from diet, 580, 586
- effect of feed calcium on strontium-to-calcium ratio of, 585
- fallout contamination of, 144, 549, 554, 569
 - comparison of levels in U.K. and N. Temperate Zone, 554
 - indicator of diet contamination, 569
- fission-product contamination of, 144-145
- importance in diet, 586
- internal dose from, 144
- nuclide contamination of, 158
- radiation effects on production of, 663
- radionuclide intake from, 570
- reduction of ^{137}Cs secretion in, 589
- reduction of radionuclide intake from, 570
- secretion of radionuclides in, 115-123
 - ^{140}Ba , 115, 118
 - ^{131}I , 115, 118
 - ^{132}Te , 115, 118
 - ^{181}W , 115, 118
 - ^{187}W , 115, 118
 - ^{188}W - ^{188}Re , 115, 118
- ^{90}Sr contamination of, 164, 553-554, 556
 - from initial fallout, 556

from soil, 553

from worldwide fallout, 556

- ^{90}Sr secretion in, 164, 553-554, 556
- Mineral nutrients loss from biota, 487

MIRV (*see* Multiple independently targetable reentry vehicle)Missiles (*see* Intercontinental missiles)

Model of fallout retention by plants, 496

Mortality, equation of insect, 522

Mosses, radiosensitivity of, 485

Mouse

See also Rodents

radiation response of, 235

Multiple independently targetable reentry vehicle (MIRV)

active defense against, 94

effectiveness of, 94-104

fatalities from, 94-104

use of decoys against, 94

vulnerability of cities to, 103

vulnerability of population to, 103

National entity survival, study of, 595

National survival, sensitivity analysis of, 595

Natural communities

- comparison with agroecosystems, 436-438

response of, to radiation dose rates, 521

Natural control of insect populations, 452

Necrosis of irradiated earthworms, 530

Negative exponential model of fallout retention by plants, 496

Net production

- of irradiated ecosystems, 459-461, 465, 474

of plants, 486

Neutron activation

- of device materials, 133-135
- of environmental materials, 133-136

Nevada Test Site (NTS), 352

Nondairy diet, calcium deficiency of, 580

Nuclear arsenal, 103

Nuclear attack (*see* Attack)

Nuclear cratering experiment (Plowshare), 115, 125

debris, 115, 125

distribution of fallout radioiodine, 260

inhalation of radioiodine by cows, 259

Palanquin, 260

program, 352

- Nuclear cratering experiment (Plowshare)
(continued)
 Schooner event, 117-124, 352
 uptake of radioiodine by cows, 260
- Nuclear force
 deployment of, 96
 second strike, 96
- Nuclear weapons
 active defense against, 94
 decoys, 94
 potential lethal radius of, 98
- Nuclides (*see* Radionuclides)
- Nutrients
 availability of, 486
 inventory of, in plant communities, 483
 mineral, loss from biota, 487
- Oats, United Kingdom stocks of, 619
- Observed ratio (O.R.body/diet) of ^{90}Sr ,
 584
- Octolasion*, fallout redistribution by, 533
- Old-field vegetation, radiosensitivity of,
 485
- Omasum, sheep
 necroses of, 186
 radiation damage of, 186, 210
- Onion
 irradiation of bulbs, 685
 irradiation of transplants, 685
- Organic matter, radioactivity of, 541
- Ornamental plants, radiosensitivity of, 687
- Orthoptera, radiosensitivity of, 525
- Outcrop plant communities
 homeostasis of irradiated, 478
 response to simulated-fallout contami-
 nation of, 457
 species response of irradiated, 468
- Particle agglomeration, 84
- Particle loss of fallout from vegetation,
 496
- Particle size of simulated fallout, 495
- Pasture
 attack loss of, 622
 grazing of contaminated, 193
 postattack requirement for livestock,
 621
 radiocontamination of, 572
- Pasture crops, radiosensitivity of, 692,
 694
- Pathology
 of abomasum, 210
 of anterior ventral blind sac, 210
 in extremis, 209
 of gastrointestinal radiation injury, 208
 of irradiated livestock, 208
 of irradiated sheep
 oral irradiation, 210, 217
 microscopic observations, 217
 oral and skin irradiation, 212
 oral and whole-body irradiation, 212
 oral, whole-body, and skin irradi-
 ation, 212
 of irradiated steers
 oral irradiation, 212
 oral and skin irradiation, 214
 oral and whole-body irradiation, 214
 oral, whole-body, and skin irradiation,
 215
 of omasum, 210
 of posterior dorsal blind sac, 210
 of posterior ventral blind sac, 210
 of reticulum, 210
 of ventral ruminal sac, 210
- Pelt of cotton rat, ^{131}Cs content of,
 541-542
- Performance of offspring of irradiated
 plants, 287
- Peripheral blood of irradiated cotton rat,
 542
- Pesticides, similarity with radiation effects
 on insects, 449
- Photosynthesis of irradiated ecosystems,
 474
- Physical dosimetry, 509
- Physical properties of fallout, 82-86
- Pigment-diversity ratio of irradiated
 Viguiera porteri, 463, 472, 478
- Placenta, radionuclide movement across,
 122-124
- Plant application of fallout simulant, 372
- Plant communities
 beta irradiation of, 465-472
 irradiated (*see* Irradiated plant com-
 munities)
 leaf-area index of, 462
 litter accumulation of, 462
 nutrient inventory in, 483
 outcrop (*see* Outcrop plant communi-
 ties)
 productivity of, 486

- radiation effects on structure of, 483, 486
- radiation exposure of, 454
- radiosensitivity of, 485
- respiration of, 483
- retention of simulated fallout by, 459
- succession of, 483
- Plant-herbivore-meat pathway, 161
 - of large fallout particles, 161
- Plant outcrop communities (*see* Outcrop plant communities)
- Plants
 - See also* Agriculture; Crops; Forest; Vegetables; Vegetation; and specific plants
 - application of fallout simulant to, 372
 - economic, 684-685
 - energy fixation by, 486
 - fallout contamination of, 501
 - factor for, 501
 - fallout effects on, 363, 670
 - interception of fallout by, 501
 - irradiated
 - climatic effects on response of, 348
 - development of axillary shoots on, 302
 - development and yield of, 287
 - developmental pattern of, 301
 - radioresistant stage of, 304
 - seed viability and vigor of, 704
 - survival of, 705
 - vegetative yield of, 301
 - yield reduction of, 698-699
 - prediction of, 705
 - irradiation of
 - acute gamma, 287
 - exposure-rate pattern of, 307, 323
 - LD₅₀, 322, 673
 - net production, 486
 - populations, stability of, 468
 - probit plot of survival of, 30
 - radiation effects on, 670
 - beta, 51, 362-363, 370, 455
 - radiation injury of, 672
 - See also* Radiation injury, of plants
 - radiocesium contamination of, 504
 - radiosensitivity of (*see* Radiosensitivity, of plants)
 - respiration of, 486
 - response of
 - to exposure rate, 306-307, 310, 314, 317-323
 - to exposure time, 306, 308
 - radiobiological, 676
 - stimulation of growth by radiation, 347, 456
 - retention of fallout by, 396-397, 401-402, 405, 493, 504
 - sensitivity of, to fallout beta radiation, 631
- Plasticity of granite-outcrop plant community, 478
- Plowshare [*see* Nuclear cratering experiment (Plowshare)]
- Population
 - of insects, 452
 - dispersion of, 452
 - protection of, 103
 - regulation in natural communities, 438
- Populations, stability of plant, 468
- Postattack dietary situation, 566
- Postattack environment, establishment of action guides for, 568
- Postattack radiation exposure, survival action guidelines for, 591
- Posterior dorsal blind sac of sheep, pathological changes in, 210
- Posterior ventral blind sac of sheep, pathological changes in, 210
- Potatoes
 - attack losses of, 622
 - irradiation of tubers, 685
 - simulated-fallout irradiation of plants, 351
 - United Kingdom stocks of, 619
 - yield of irradiated plants, 683
- Poultry
 - fallout exposure of, 662
 - radiation effects on, 664
- Prediction
 - of LD₅₀ of woody plants, 700-701
 - of radionuclide contamination of milk, 571-572
 - of radionuclide intake from milk, 570
 - of radiosensitivity of arthropods, 521
 - of yield of irradiated plants, 698-699
- Primary production of plants, 486
- Probit plot of plant survival, 30
- Processing, reduction of ⁹⁰Sr contamination by, 579
- Productivity
 - of plants, 486
 - of plant communities, 486
- Project Schooner, 352

- Protection, radioinduced (*see* Radioinduced protection)
- Protection factor, 97-98
- Protective Action Guide (PAG), 568
of radionuclide intake, 568
- Protective agent, radiation, 239
- Protein content of irradiated crops, 675
- Prussian blue (ferric ferrocyanide)
cesium absorption by, 589
as control of cesium secretion in milk, 589
as dietary countermeasure, 589
- Pyrexia
of internally irradiated sheep, 181
of internally irradiated steers, 196
- Radiation
attenuation of plant containers, 288
beta (*see* Beta radiation; Beta radiation, fallout)
damage, repair of, 522
effects
See also Radiation injury; Radiation sickness
combined, on livestock, 660
of fallout on a grass community, 542
on life-span, 666
on livestock, 193, 663
on livestock productivity, 663
on meat production, 663
on milk production, 663
on performance of work, 665-666
on plants, 670
on poultry, 664
on sheep, 178, 180
exposure to (*see* Radiation exposure)
fallout (*see* Fallout radiation)
from fallout particles, 31
gamma (*see* Gamma radiation)
genetic effects of, 245, 248, 666
hazard of fallout, 496
inhalation exposure to, calculation from air-sampler data, 259
internal, hazard of postattack foods, 555-559
lethal exposure to, 246
lethality
See also LD₅₀
of crops, 600
of livestock, 657
long-term effects on arthropods, 509
recovery of bone marrow from, 252
reduction of seed yield by, 680
response of adventitious buds to, 325
safeguards of dietary fallout contamination, 567
sensitivity to
See also Radiosensitivity
of plants, 349
of soil invertebrates, 529
shielding of vegetation from, 367
short-term effects on insects, 509
sickness, symptoms of, 658
source (¹³⁷Cs), 483
stimulation of plant growth by, 347
- Radiation dose
See also Dose; Radiation exposure
biological indicators of, 235-237
in bone marrow, 235
DNA content of bone marrow, 237
DNA content of spleen, 237
germinal cells of skin, 236
intestinal epithelium, 236
stem cells, 235
weight of spleen, 237
weight of testes of mice, 235, 237
weight of thymus, 237
estimation of, by radiological safety monitoring, 358
measurement of, 353
from ⁹⁰Sr in bone marrow, 557
threshold, 599
- Radiation dose rate, response of natural populations to, 521
See also Dose-rate effect
- Radiation dosimeter, 57
See also Dosimeter
- Radiation effects (*see* Radiation)
- Radiation exposure
of arthropods, 521
calculations of, use of air-sampler data in, 259
continuous to death, 227
duration of, response of plants to variations of, 306, 308, 310
fallout (*see* Fallout radiation)
guidelines of, 568
hematologic changes following, 227
index of, 568
of insects, 509
of large animals, 224, 227
nonlethal, 246
rate of (*see* Exposure rate)
recovery from, 245

- of shrubs, 353
- of soybean plants, 282
- Radiation field
 - See also* Fallout radiation field
 - I_s (standard intensity), 91, 597
 - simulated fallout, 472
- Radiation injury
 - of abomasum, 178, 193, 210
 - of barley, 348
 - germinating seeds, 310
 - beta induced, 31, 37, 199
 - biological end points of, 234-235
 - of *Bulbostylis capillaris*, 476
 - of cattle, 193, 210, 659
 - criteria of, 234
 - of earthworms, 530
 - gastrointestinal, 186, 208, 210, 212, 217
 - hematopoietic recovery from, 248
 - irreparable component of, 252
 - of large animals, 224
 - of liver, 190
 - of livestock, 193, 210, 659
 - of lung, 187
 - measurement of, 235
 - colony-forming unit (CFU), 235
 - erythropoietin response, 235
 - stem cells, 235
 - survival fraction (S/S_0), 235
 - of plants
 - climatic effects on, 348
 - expression of, 672
 - influence of exposure duration on, 677
 - influence of postirradiation time on, 679
 - influence of stage of development on, 678
 - time of development of, 670
 - recovery from, 245
 - rate of, 248
 - repair of, 241, 285, 522
 - replacement of destroyed tissue from, 241
 - response curve of, 672
 - of rumen, 178, 193
 - of sheep, 178, 180, 186, 193
 - See also* Sheep
 - of vegetation, 363
 - of *Viguiera porteri*, 475
- Radiation protective agent, 239
- Radiation sickness, symptoms of, 658
- Radiation source
 - ^{60}Co , 455
 - ^{137}Cs , 307, 483
- Radioactive contamination of crops by fallout, 343
- Radioactive fallout, 107
 - See also* Fallout; Fallout simulant; Simulated fallout; and Synthetic fallout
 - contamination of crops by, 343
 - of stratospheric debris, 343
 - of tropospheric debris, 343
- Radiobiological effects of fallout, 82
- Radiobiological response of plants, 676
 - biological factors, 676
 - environmental factors, 676
 - radiological factors, 676
- Radiobiological research requirements, 636
- Radiocesium
 - See also* Cesium-137
 - content of vegetation, 504
- Radiochemical purity of ^{90}Y fallout simulant, 371
- Radioecological effects of fallout, committee report on, 643
- Radioinduced protection
 - of initial dose, 325, 330
 - of multiple irradiations, 325, 334
 - of time between irradiations, 325, 327, 330
- Radioiodine, 259-260
 - See also* Iodine-131
 - in abomasal tissue of dairy cows, 259
 - airborne, inhalation by dairy cows, 259
 - distribution of fallout, 260
 - in thyroid of dairy cows, 259
- Radiological hazard
 - of external gamma radiation, 82, 86
 - of fallout, 86
 - I_s (standard intensity) assessment of, 91
- Radiological safety monitoring, estimation of radiation dose by, 358
- Radionuclides
 - See also* Fallout radionuclides; specific radionuclides
 - assimilation of ingested, 125-129
 - ^{74}As , 125-129
 - ^{198}Au , 125-129
 - ^{140}Ba - ^{140}La , 125-129
 - ^{141}Ce , 125-129
 - ^{58}Co , 125-129
 - ^{131}I , 125-129
 - ^{54}Mn , 125-129

- Radionuclides (continued)
- ⁹⁹Mo, 125-129
 - ¹⁰³Ru, 125-129
 - ¹²²Sb, 125-129
 - ¹³²Te, 125-129
 - ¹⁸⁷W, 125-129
 - ¹⁸⁸W-¹⁸⁸Re, 125-129
- biological availability of, 125
- body burden of, urinary assay of, 576
- diffusion in fallout particles, 83
- excretion of, 125
- See also* Fallout radionuclides, excretion of
- fission product, 82
- formation of
- by neutron capture, 82
 - by nuclear fission, 82
- fractional condensation of, 83
- ingestion of, 131
- control of, 268
 - protective action measures against, 568
- intake
- dietary control of, 579
 - indicators of, 574
- intake commitment from milk, 570
- in meat, 161
- activation product, 161
 - concentration of, 161
 - fission product, 161
- retention of ingested, 115, 125
- secretion in milk, 144, 158
- stratospheric fallout of, 156-157
- time-related ranking of major, 569
- vaporization of, 83
- Radioprotective agent, AET, 239
- Radioresistant stage of plant development, 304
- Radiosensitivity
- of algae, 485
 - of arthropod populations, 521
 - of cereal crops, 688, 693
 - of coniferous forests, 489
 - correlation with ICV, 419
 - of crabgrass (*Digitaria* species), 486
 - of crop plants, 704
 - of deciduous forests, 489
 - of earthworms (*Lumbricus terrestris*), to beta radiation, 527-528
 - of edible legumes, 689, 693
 - of 82 species of woody plants, 700-701
 - of 89 species of economic plants, 698-699
 - of equine to fallout, 662
 - of *Folsomia* (Collembola), 509-510, 517-518
 - of forage crops, 692-694
 - of forest vegetation, 483-486
 - of fruits, 691, 694
 - of fungi, 485
 - of herbs, 485
 - of human cells, 237
 - of insects, 434
 - prediction of, 426-430
 - of lichens, 485
 - of maize (*Zea Mays*), 679
 - of mammals, prediction of, 420-425
 - of microfauna, 485
 - of mosses, 485
 - of old-field vegetation, 485
 - of Orthoptera, 525
 - of pasture crops, 692, 694
 - of plants, 88, 302, 349, 670, 704
 - to beta radiation, 631
 - effect of exposure rate on, 670
 - effect of stage of development on, 670
 - environmental influences on, 670, 679-681, 702
 - competition, 702
 - light, 702
 - temperature, 702
 - modifying factors influencing, 675-677
 - ornamental, 687
 - prediction of, 670, 685, 687-692, 694, 695, 697-701, 703
 - interphase chromosome volume (ICV), 670, 673-674, 695-696
 - range of, 702
 - of rodents, prediction, 421-426
 - of root crops, 690, 693
 - of sedge (*Carex pensylvanica*), 486
 - seed, correlation with plant radiosensitivity, 686
 - of shrubs, 485
 - of *Sinella curviseta*, 518
 - of trees, 483, 485, 694
 - of 25 species of ornamental plants, 687
 - of vegetable crops, 691, 694
 - of weeds, 485
 - of woody ecosystems, 703
 - of woody plants, 694
- Radiotungsten
- in fetal bone, 115
 - in maternal organs, 115

- Rate of hematopoietic recovery, 248
- Rationing of postattack food supplies, 578-579
- RBE (*see* Relative Biological Effectiveness)
- Recovery
of disturbed vegetation, 487
of radiation injury, 285
rate of hematopoietic, 248
- Redistribution of fallout by earthworms, 532-533
- Relative Biological Effectiveness (RBE) of beta radiation, 477
- Remedial action plans
for control of contaminated food, 560
for decontamination of milk, 560
- Repair of radiation injury, 241, 245, 248, 285, 522
- Reproduction
of irradiated livestock, 665
of irradiated *Viguiera porteri*, 477
- Research data, use in agricultural damage assessment, 611
- Residual carcass, ^{137}Cs concentration in cotton rat, 541-542
- Respiration
of irradiated ecosystems, 459-461, 465, 474, 479
of plant communities, 483
of plants, 486
- Response curve of radiation injury, 672
- Retention
See also Fallout, retention of
of ingested radionuclides, 125
of simulated fallout by plant community, 459
- Reticulum, pathological changes in sheep, 210
- Rodents
See also Mouse
prediction of radiosensitivity of, 421-426
- Root crops, radiosensitivity of, 690, 693
- Rubidium-86 fallout simulant, 494-495
- Rumen, radiation injury to, 178, 193
- Rye, chronic irradiation of, 348
- Salvage of irradiated livestock, 269
- San Joaquin Valley
agriculture of, 447
important insect pests of, 448
- Schooner fallout
ingestion by cows, 117-124
secretion in milk, 117-124
- Sedge (*Carex pensylvanica*), radiosensitivity of, 486
- Seed grain, irradiation of, 685
- Seed radiosensitivity
correlation with plant radiosensitivity, 686
effect of moisture content on, 686
effect of oxygen on, 686
- Seed yield, radiation reduction of, 680
- Seedlings
of irradiated parent plants, emergence of, 289
irradiation of, 307, 310
- Semilogarithmic regression model of fall-out weathering, 500-501
- Sensitivity analysis
of agricultural assessment parameters, 602
of agricultural resource distribution, 603
of agricultural vulnerability, 596
of attack date, 602
of attack weight, 605
of crop vulnerability, 607
of dose-rate multiplier, 605
of national survival, 595
of total-to-gamma dose ratio, 602
- Shape of irradiated crops, 675
- Sheep
beta irradiation of skin of, 187
impairment of wool growth due to, 187
beta irradiation of abomasum of, 185
body weight of internally irradiated, 180
 ^{60}Co irradiation of, 179
continuous irradiation of, 651
excretion of fallout by, 173
fallout exposure of, 662
feed intake of irradiated, 180
gamma irradiation of, 178
gastrointestinal irradiation of, 178
hematologic changes in irradiated, 227
 LD_{50} of, 187, 225, 650
lethality of continuously irradiated, 227
mean survival time of, 651
measurement of GI-tract beta dose of, 185-186
pathology of internal radiation injury of, 210

- Sheep (continued)
- radiation-induced injury of, 180, 186, 193
 - to abomasum, 178, 210
 - prolapse, 186
 - adhesions, 186
 - anorexia, 180
 - diarrhea, 180
 - edematous laminae, 186
 - gastrointestinal, 186
 - microscopic observations of, 217
 - hemorrhage, 186
 - hyperemic pylorus, 186
 - to intestine, 186
 - liver abscesses, 190
 - to lung, 187
 - necrosis of omasum, 186, 210
 - pyrexia, 181
 - to rumen, 178
 - simulated-fallout effects on mortality of, 661
 - skin irradiation of, 178
 - use of dosimeters in GI-tract of, 185
 - weight loss of irradiated, 181
- Shielding, soil, 530
- of beta radiation, 531
 - of earthworms, 533
- Shielding of soil-dwelling organisms, 530
- Shoot dry weight of irradiated soybean plants, 280
- Short-term radiation exposure of insects, 509
- Shrubs
- fallout contamination of, 352
 - radiation exposure of, 353
- Simulated fallout, 454, 458
- See also* Fallout simulant;
- Synthetic fallout
- contamination of outcrop plant communities by, 457
 - effects on cattle, 661
 - effects on sheep, 661
 - experimental use of, 510
 - exposure to
 - of higher plants, 455
 - of potato plants, 351
 - rate of, 307
 - internal effects of ingested, 178
 - mass load of, 495
 - radiation effects on livestock, 193
 - radiation field of, 472
 - retention by plant communities, 459
 - ^{90}Y tagged, 458
- Sinella curviseta*, radiosensitivity of, 518
- Skin
- beta burns of, 31
 - beta irradiation of, 187, 193
 - beta lesions of, 37
 - beta radiation effects on, 199
 - erythema of irradiated, 187
 - germinal cells, 236
 - hyperkeratosis of irradiated, 199
 - irradiation of sheep, 178
- Sodium alginates, inhibition of ^{90}Sr absorption by, 588
- Soil
- beta exposure of surface, 476
 - ingress of simulated fallout, 472
 - radioactivity of, 464
 - shielding of beta radiation by, 531
 - shielding of earthworms by, 533
 - shielding properties of, 530
 - ^{90}Sr in, food contamination by, 549
- Soil invertebrates
- radiosensitivity of, 529
 - shielding of, 530
- Soil-uptake contamination of food, analysis of, 549-554
- Sorghum, fallout retention by, 499
- Source term, fallout, of food contamination, 504
- Soybean (*Glycine max* (L.) Merrill), response to gamma-ray exposures, 277
- Soybean plants
- irradiated, 277-280
 - recovery of, 285
 - repair of, 285
 - shoot dry weight of, 280
 - stem length of, 280
 - yield of, 281-282
 - split-exposure irradiation of, 278
- Species composition dissimilarity, index of insect, 514
- Species of ecosystem, diversity of, 475
- Spleen
- DNA content of, 237
 - weight in mice, 237
- Split-exposure irradiation of soybean plants, 278
- Spring wheat (*Triticum aestivum*), irradiation of, 308
- Spruce budworm [*Chorestoneura fumiferana* (Clemens)], 348

- Stage of plant development, effect on radiation response of, 288
- Standard intensity (I_s), 91
prediction of, 597
of residual fallout radiation, 91
- Starch content of irradiated crops, 675
- Stem cells, indicator of radiation injury, 235
- Stem length of irradiated soybean plants, 280
- Stimulation of plant growth by radiation, 347
- Stockpiles, weapons, 103
- Stratospheric fallout, contamination of crops by, 343
- Stress of radiation on ecosystems, 474
- Strontium-90
absorption of, from the gut, 586
body burden of
reduction of, 584
urinary assay of, 576
bone-marrow dose from, 557-558
contamination of food
processing reduction of, 579
from soil uptake of, 553
contamination of food chains, soil contribution to, 549
decontamination of milk, 585
estimation of dietary levels of, 575
fallout contamination of milk, 164, 553-554
comparison of U.K. and N. Temperate Zone, 554
initial, 556
worldwide, 556
feeding countermeasures to control absorption of, 586
alginates, 586
aluminum phosphate gel, 586
intake
commitment from milk, 570
dietary control of, 579, 585
effect of milk on, 586
reduction by supplemental calcium, 580
internal dose from, 549
secretion in milk, 164, 553-554, 556
reduction of, 584
selective inhibition of absorption of, 588
effect of alginates on, 588
in surface air, 164
- Structure of plant communities, 483, 486
radiation effects on, 483, 486
- Subhumid environment, assimilation of fallout by plants in, 504
- Succession
of natural ecosystems, 475
of plant communities, 483
- Sugar content of irradiated crops, 675
- Surface contamination,
beta radiation hazard of fallout, 352
- Survey of worldwide fallout contamination of food, 549
- Survival
of animals
effect of fallout on, 193
enhancement of, 193, 625
in relation to cell destruction, 238
of irradiated crops, 313
of irradiated lettuce seedlings, 308, 310
of irradiated plant seedlings, 310
of irradiated plants, 306, 322, 688
national, sensitivity analysis of, 595
- Survival action guidelines, development of, 568
- Survival end points of radiation injury, 672
 LD_{10} , 672
 LD_{50} , 672
 LD_{90} , 672
 LD_{100} , 672
 YD_{10} , 672
 YD_{50} , 672
 YD_{90} , 672
- Survival fraction (S/S_0), 235
- Survival guidelines of postattack radiation exposure, 591
- Survival time
of continuously irradiated goats, 651
of continuously irradiated sheep, 651
- Swine
fallout exposure of, 662
fate of fallout ingested by, 125
 LD_{50} of, 650
mean survival time of, 651
radiation lethality of, 657
- Symptoms of radiation sickness, 658
- Synthetic fallout, 107
See also Simulated fallout
cesium tagged, accumulation by cotton rat, 536
ingestion by livestock, 178, 193
preparation of, 108

- Tall fescue (*Festuca arundinacea*, Shreb),
 fallout retention by, 493
- Targeting, pattern of, 88
 effects on agricultural vulnerability, 88
- Taste of irradiated crops, 675
- Temporary equilibrium position of insect
 populations, 452
- Terminal buds
 lethality of irradiated, 479
 mortality of irradiated *Viguiera porteri*,
 463, 471
 radiosensitivity of, 477
 retention of fallout by, 464, 473
- Testes, radiation effects on weight of
 mice, 236
- Thermoluminescent dosimetry of beta
 and gamma radiation, 509
- Threshold
 economic
 of insect pests, 451
 of pest arthropods, 441
 radiation, of effects on an arthropod
 community, 509
- Threshold dose (LD/8) of radiation, 599
- Thymus, radiation effects on weight of,
 237
- Thyroid
 concentration of airborne radioiodine
 in, 259
 ^{131}I dose to, 548
 ingested fallout dose to, 161
 prevention of ^{131}I accumulation by,
 581
 use of stable iodine in, 581
- Tissue
 abomasal, concentration of airborne
 radioiodine in, 259
 fallout ^{137}Cs accumulation by cotton
 rat, 536, 541
- Tomato plants, fruit set of irradiated, 682
- Total-to-gamma dose ratio
 of fallout, 600, 603
 sensitivity analysis of, 602
- Total intake commitment of radionuclides
 from milk, 572
- Transfer, of fission products in food
 chain, 560
- Trees
See also Forest
 chronic irradiation of, 483
 fruit, radiosensitivity of, 691, 694
 hardwood, radiosensitivity of, 694
 radiosensitivity of, 483, 485
 retention of fallout by, 401-402
- Tritium, 136
 dose from, 77
 comparison with external gamma dose,
 77
 dosimetry of, 72-75
 fallout of, 74-75
 importance of, 71-77
- Tropospheric fallout, contamination of
 crops by, 343
- United Kingdom
 grain stocks in, 619-620
 barley, 619
 oats, 619
 wheat, 619
 peacetime food imports of, 617
 postattack availability of meat in, 622
 postattack food resources of, 616
 postattack requirement for grain in, 624
 postattack survival of livestock in, 621
 postattack yield of grains in, 624
 potato stocks in, 619
 ^{90}Sr contamination of milk in, 554
 total food stocks in, 617
- United States, geographic distribution of
 food in, 577
- Uptake of inhaled radioiodine, 259
- Urinary assay of radionuclide body
 burden, 576
- Vaporization of radioelements, 83
- Vegetables, radiosensitivity of, 691, 694
- Vegetation
See also Forest; Plants; and specific
 types of vegetation
 dosimetry of, 354
 fallout beta-radiation exposure of,
 353, 362-363, 455
 fallout contamination of, 501
 factor for, 501
 fallout gamma-ray exposure of, 360-361
 fallout radiation injury of, 363
 recovery of disturbed, 487
- Vegetative yield of irradiated plants, 301
- Ventral ruminal sac of sheep, 210
 radiation-induced pathological changes
 in, 210
- Viguiera porteri* (A. Gray)
 beta irradiation of, 458

- growth in irradiated plant communities,
 462, 468
 irradiated
 biomass of, 477
 growth of, 462, 471, 476-477
 lateral branching of, 479
 Margalef ratio of, 463
 pigment changes of, 478
 pigment-diversity ratio of, 463, 472
 reproduction of, 477
 response of, 475
 stunting of, 478
 terminal-bud mortality of, 463, 471
 response of, to stress, 479
 Vulnerability
 See also Radiosensitivity
 of agriculture to nuclear attack, 495-596
 of crops to fallout beta radiation, 630
 of livestock to fallout radiation, 627
 Vulnerable period of crop growth, 607
- Water decontamination, 590
 effectiveness of home water softeners
 in, 590
 effectiveness of water-treatment
 processes in, 590
 Weapons system
 current, 88-91
 future, 91-104
 MIRV, 91-104
 Weathering
 of fallout from plants, 400, 500
 of fallout from vegetation, 496
 Weathering function of fallout
 particles on plants, 496
 Weeds
 net productivity of, 486
 radiosensitivity of, 485
 Wheat
 attack loss of, 622
 beta irradiation of, 370
 chronic irradiation of, 348
 irradiated
 dose-rate effects on lethality of, 323
 constant-rate exposure of, 322
 fallout-simulated exposure of, 322
 survival of, 310
 yield of, 683
 irradiation of, 306
 LD₅₀ of, 306, 318, 322
 United Kingdom stocks of, 619
 Whole-body dose of fallout gamma
 radiation, 161, 539
 Whole-body fallout radioactivity of cotton
 rat, 536, 541
 Whole-body irradiation
 lethality of, 224
 of livestock, 193
 of sheep, 227
 Wholesomeness of irradiated crops, 675
 Woody plants
 LD₅₀ of, 700-701
 radiosensitivity of, 694
 Wool growth, radiation impairment of,
 187
 Work, radiation effects on performance
 of, 665-666
 Worldwide fallout, contamination of food-
 stuff by, 549
- YD₅₀/LD₁₀ relation, 675, 696-697
 YD₅₀ (yield-reduction factor) of
 economic plants, 698-699
 Yield
 of irradiated barley, 683
 of irradiated crops, 313
 of irradiated lettuce seedlings, 308,
 310
 of irradiated plants, 287, 306, 322, 684,
 704
 of irradiated potatoes, 683
 of irradiated soybean plants, 281-282
 of irradiated wheat, 683
 Yield-reduction factor (*see* YD₅₀)
 Yttrium-90
 fallout simulant, radiochemical purity
 of, 371
 ingestion of, 178, 193
 by livestock, 193, 210, 627, 659-660
 by sheep, 173, 178, 180, 186
 irradiation of plant communities, 458
 synthetic fallout label of, 178, 193
 Yttrium-90 tagged sand
 beta dose from, 473
 fallout simulant of, 178, 193, 371

— NOTICE —

This book was prepared under the sponsorship of the United States Government. Neither the United States nor the United States Atomic Energy Commission, nor any of their employees, nor any of their contractors, subcontractors, or their employees, makes any warranty, express or implied, or assumes any legal liability or responsibility for the accuracy, completeness or usefulness of any information, apparatus, product or process disclosed, or represents that its use would not infringe privately owned rights.

AEC CRITICAL REVIEW SERIES

As a continuing series of state-of-the-art studies published by the AEC Office of Information Services, the AEC Critical Reviews are designed to evaluate the existing state of knowledge in a specific and limited field of interest, to identify significant developments, both published and unpublished, and to synthesize new concepts out of the contributions of many.

SOURCES OF TRITIUM AND ITS BEHAVIOR UPON RELEASE TO THE ENVIRONMENT

December 1968 (TID-24635) \$6.00
D. G. Jacobs
Oak Ridge National Laboratory

REACTOR-NOISE ANALYSIS IN THE TIME DOMAIN

April 1969 (TID-24512) \$6.00
Nicola Pacilio
Argonne National Laboratory
and Comitato Nazionale
per l'Energia Nucleare

PLUME RISE

November 1969 (TID-25075) \$6.00
G. A. Briggs
Environmental Science Services
Administration

THE ANALYSIS OF ELEMENTAL BORON

November 1970 (TID-25190) \$3.00
Morris W. Lerner
New Brunswick Laboratory

ATMOSPHERIC TRANSPORT PROCESSES

Part 1: Energy Transfers
and Transformations
December 1969 (TID-24868) \$6.00

Part 2: Chemical Tracers
January 1971 (TID-25314) \$6.00
Elmar R. Reiter
Colorado State University

AERODYNAMIC CHARACTERISTICS OF ATMOSPHERIC BOUNDARY LAYERS

May 1971 (TID-25465) \$3.00
Erich J. Plate
Argonne National Laboratory
and Karlsruhe University

NUCLEAR-EXPLOSION SEISMOLOGY

September 1971 (TID-25572) \$3.00
Howard C. Rodean
Lawrence Livermore Laboratory

A TROPICAL RAIN FOREST

A Study of Irradiation and Ecology at El Verde, Puerto Rico

HOWARD T. ODUM
Editor and Project Director

ROBERT F. PIGEON
Associate Editor

An intensive ecological study of several hectares of montane rain forest was made during the 1960s in the Luquillo National Forest in eastern Puerto Rico. The operation of the normal forest was studied and compared with a zone that for three months received gamma-radiation stress from a 10,000-curie cesium source that had been airlifted into the forest. The book reports the scientific results of the project, which used many techniques of systems ecology in the quest of understanding one of the most complex ecosystems on earth. Included in nine main divisions (111 chapters) are maps, tables of tree numbers, and taxonomic keys to facilitate new efforts at the El Verde site toward finding the best designs for man and nature in broad tropic lands. 1678 pp. 1170 illus., 8½ × 11. Published in 1970 by the Office of Information Services, U. S. Atomic Energy Commission.

Contents

THE RAIN FOREST PROJECT
THE RAIN FOREST AT EL VERDE
THE RADIATION EXPERIMENT
PLANTS AND THE EFFECTS OF RADIATION
ANIMALS AND THE EFFECTS OF RADIATION
MICROORGANISMS AND THE EFFECTS OF RADIATION
CYTOLOGICAL STUDIES WITHIN THE IRRADIATED FOREST
MINERAL CYCLING AND SOILS
FOREST METABOLISM AND ENERGY FLOWS

Available as TID-24270 for \$10.00 from
National Technical Information Service
U. S. Department of Commerce
Springfield, Virginia 22151

NATIONAL AGRICULTURAL LIBRARY



1022312223

NUCLEAR SCIENCE ABSTRACTS

Nuclear Science Abstracts, a semimonthly publication of the U. S. Atomic Energy Commission, provides comprehensive abstracting and indexing coverage of the international literature on nuclear science and technology. It covers (1) research reports of the U. S. Atomic Energy Commission and its contractors; (2) research reports of other government agencies, universities, and industrial research organizations on a worldwide basis; and (3) translations, patents, conference papers and proceedings, books, and articles appearing in technical and scientific journals.

INDEXES

Indexes covering subject, author, corporate author, and report number are included in each issue. These indexes, which are cumulated and sold separately, provide a detailed and convenient key to the world's nuclear literature.

EXCHANGE

Nuclear Science Abstracts is available on an exchange basis to universities, research institutions, industrial firms, and publishers of scientific information; inquiries regarding the exchange provision should be directed to the USAEC Technical Information Center, P. O. Box 62, Oak Ridge, Tennessee 37830.

SUBSCRIPTIONS

Nuclear Science Abstracts is available on subscription from the Superintendent of Documents, U. S. Government Printing Office, Washington, D. C. 20402, at \$42.00 per year for the semimonthly abstract issues and \$34.50 per year for the cumulated-index issues. Subscriptions are postpaid within the United States, Canada, Mexico, and most Central and South American countries. Postage is not paid for Argentina, Brazil, Guyana, French Guiana, Surinam, and British Honduras. Subscribers in these countries and in all other countries throughout the world should remit \$52.50 per year for the semimonthly abstract issues and \$43.00 per year for the cumulated-index issues.



1022312223

AEC SYMPOSIUM SERIES

- 1 Progress in Medical Radioisotope Scanning (TID-7673), 1963, \$6.00
- 2 Reactor Kinetics and Control (TID-7662), 1964, \$6.00
- 3 Dynamic Clinical Studies with Radioisotopes (TID-7678), 1964, \$6.00
- 4 Noise Analysis in Nuclear Systems (TID-7679), 1964, \$6.00
- 5 Radioactive Fallout from Nuclear Weapons Tests (CONF-765), 1965, \$6.00
- 6 Radioactive Pharmaceuticals (CONF-651111), 1966, \$6.00
- 7 Neutron Dynamics and Control (CONF-650413), 1966, \$6.00
- 8 Luminescence Dosimetry (CONF-650637), 1967, \$6.00
- 9 Neutron Noise, Waves, and Pulse Propagation (CONF-660206), 1967, \$6.00
- 10 Use of Computers in the Analysis of Experimental Data and the Control of Nuclear Facilities (CONF-660527), 1967, \$6.00
- 11 Compartments, Pools, and Spaces in Medical Physiology (CONF-661010), 1967, \$6.00
- 12 Thorium Fuel Cycle (CONF-660524), 1968, \$6.00
- 13 Radioisotopes in Medicine: In Vitro Studies (CONF-671111), 1968, \$6.00
- 14 Abundant Nuclear Energy (CONF-680810), 1969, \$6.00
- 15 Fast Burst Reactors (CONF-690102), 1969, \$ 6.00
- 16 Biological Implications of the Nuclear Age (CONF-690303), 1969, \$6.00
- 17 Radiation Biology of the Fetal and Juvenile Mammal (CONF-690501), 1969, \$6.00
- 18 Inhalation Carcinogenesis (CONF-691001), 1970, \$6.00
- 19 Myeloproliferative Disorders of Animals and Man (CONF-680529), 1970, \$9.00
- 20 Medical Radionuclides: Radiation Dose and Effects (CONF-691212), 1970, \$6.00
- 21 Morphology of Experimental Respiratory Carcinogenesis (CONF-700501), 1970, \$6.00
- 22 Precipitation Scavenging (1970) (CONF-700601), 1970, \$6.00
- 23 Neutron Standards and Flux Normalization (CONF-701002), 1971, \$6.00
- 24 Survival of Food Crops and Livestock in the Event of Nuclear War (CONF-700909), 1971, \$9.00

AVAILABLE FROM:

National Technical Information Service
U. S. Department of Commerce
Springfield, Virginia 22151